

TT

520

.D62

THE SELF-BALANCING SYSTEM,

OR

The Cutters' Guide.

BY

DITTMAR & SHEIFER,

NEW YORK.

LIBRARY OF CONGRESS.

Chap. Copyright Pa.  
Section I.

UNITED STATES OF AMERICA.









THE SELF-BALANCING SYSTEM  
OF  
CUTTING LADIES' GARMENTS,  
BY  
DITTMAR & SHEIFER,  
INCLUDING SCALES OF THE SELF-BALANCING SYSTEM  
FOR CUTTING.

PUBLISHED IN NEW YORK BY

DITTMAR & SHEIFER,

Authors of Dittmar & Sheifer's Self Balancing System of Cutting Gents' and Boys' Garments. D. & S. Proportions on Ladies' and Children's Garments. D. & S. Proportions on Men's, Youth's, Boys' and Children's Garments.  
D. & S. Self-Balancing System of Cutting Shirts.  
D. & S. Book on Grading, etc., etc.

FOR CONTENTS, CONSULT INDEX ON LAST PAGE.

Entered according to Act of Congress in the year 1891 by DITTMAR & SHEIFER, in the Office of the Librarian of Congress at Washington.

CAUTION.—A legal right to use this work must show its conveyance to the subscriber by its number and license, with the signatures of the Authors.

Any infringement or unauthorized use will be prosecuted to the full extent of the Law, it having been decided by the Librarian that the contents are fully covered and protected by the copyright.

No. of Book,

*1*

Authors,

*Dittmar Sheifer*



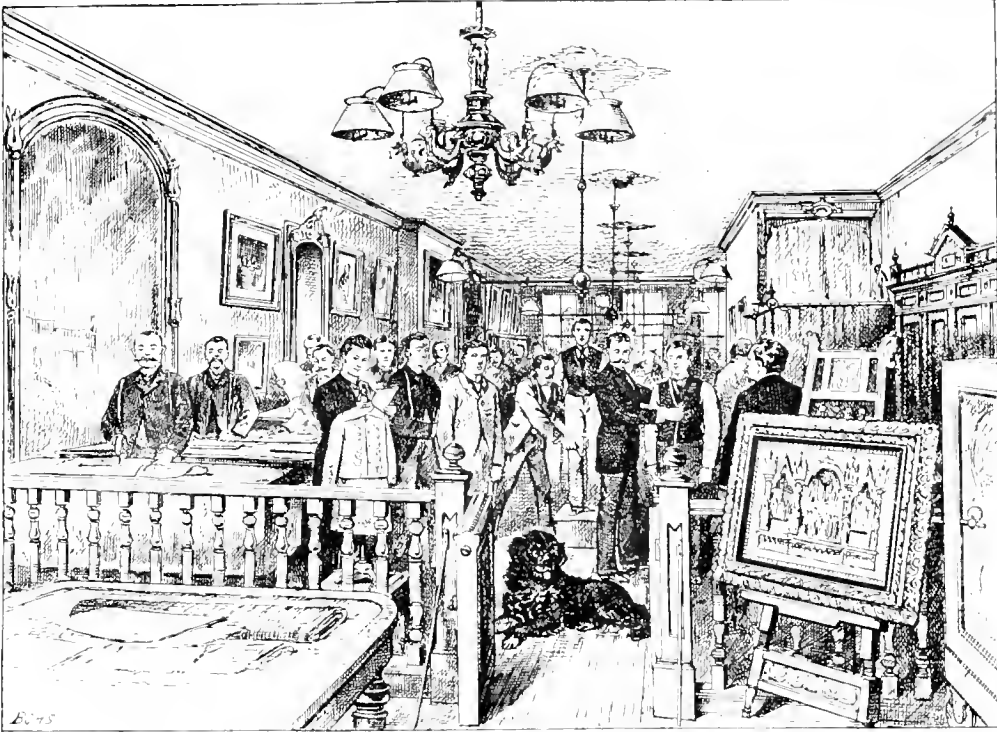

CUSTOM DEPARTMENT

OF THE

Tailors' and Cutters' Exchange.

**T**HE facilities of this Academy for imparting reliable and thorough instruction in Ladies' and Gents' Garment Cutting are not equaled in this country. The systems taught have received the unqualified indorsement of the Cutting fraternity as correct in theory and reliable in practice. To those who are not practical Cutters the charge is **One Hundred Dollars** for a thorough and complete course of instruction in Garment Cutting; but to **Practical Cutters**, not occupying more than one week or ten days at the outside in learning, the charge is **Fifty Dollars**. The time occupied by students in acquiring a perfect knowledge of Cutting averages from three to six weeks. *No limit* is placed upon the time to be occupied by young beginners, as we desire that they shall not leave the Academy until we are satisfied of their efficiency.

The Academy is open for instruction daily (Saturday and Sunday excepted) from 10 A.M. to 3 P.M., and pupils may commence at any time.

WHOLESALE DEPARTMENT

OF THE

Tailors' and Cutters' Exchange.

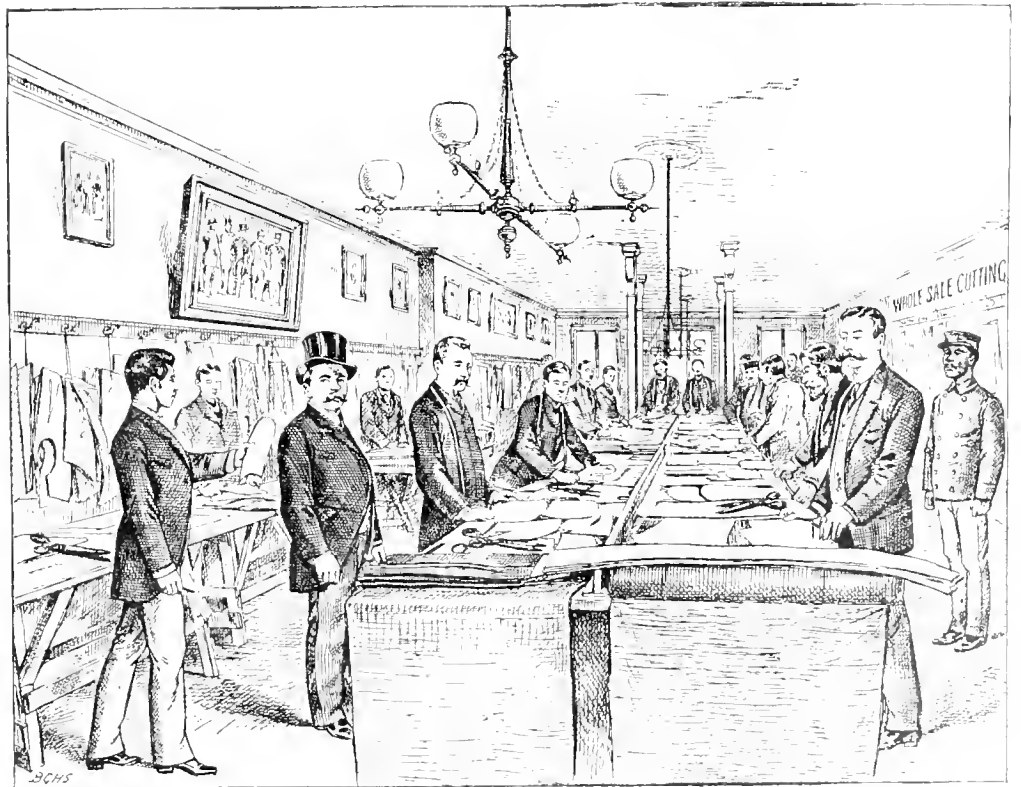

## PREFACE.

**I**N presenting this work, we have the assurance of meeting the wants of the trade, by furnishing a system of actual measurement, combining pure geometrical principles with simplicity, in drafting all styles of *over* and *under-coats*, with the use of *tape-measure* only; it is a system of measuring and drafting that will reach every shape, thereby giving us the high or low shoulder, erect or stooping form, shoulder, backward or forwards, narrow or wide arm-eye, narrow or wide backstrop; in fact, producing a correct draft for all forms in as simple a manner as possible.

With pleasure we call the attention of the public in general, especially the Tailors, to our "NEW AND IMPROVED SYSTEM" of cutting perfect fitting garments, a system simple in its construction, based on mathematical and practical principles, which can easily be mastered, and will compensate the pupil a thousand times over with its results. It has afforded many years of study and experimenting, and stands without a rival in Europe and America.

---

### ITS SIMPLICITY.

The greatest importance attached to all mechanism is its simplicity; without it we have complications which are liable to get out of order and cause trouble, but when everything is simple there are fewer chances of its causing annoyance and trouble. So it is with a system;

too many of them being so complicated and call for so many measures, etc., that a student is perplexed at the multiplicity of his work and the numerous changes necessary to be made to successfully work the system.

We would guard you against learning a system containing too many calculations; the more simple they are, the less liable you are to err in using them.

---

### ITS RELIABILITY.

In an engine the *desideratum* to be attained is reliability. When this point is satisfactorily settled there is no hesitancy upon the part of the builders to recommend it. They are then satisfied that its work will be thoroughly done, and they have no fear of failure.

In this system of cutting its reliability has been settled beyond a question, and we have the proofs to offer which are open to the inspection of all interested parties.

---

### ITS SWIFTNESS OF EXECUTION.

In these days of hurry, when *time* is reckoned so valuable that minutes as well as hours are considered, we all aim to economize time as much as possible; "time is money," therefore it is desirable in selecting a system to get one that produces good results and consumes the least time in drafting the garment, for in so doing we are selecting THE BEST-PAYING system.

This system is not only simple in its construction, reliable in its results, but occupies less time to make a correct draft than any other offered. Hence it is pre-eminently to your advantage to learn it, for "economy is wealth."

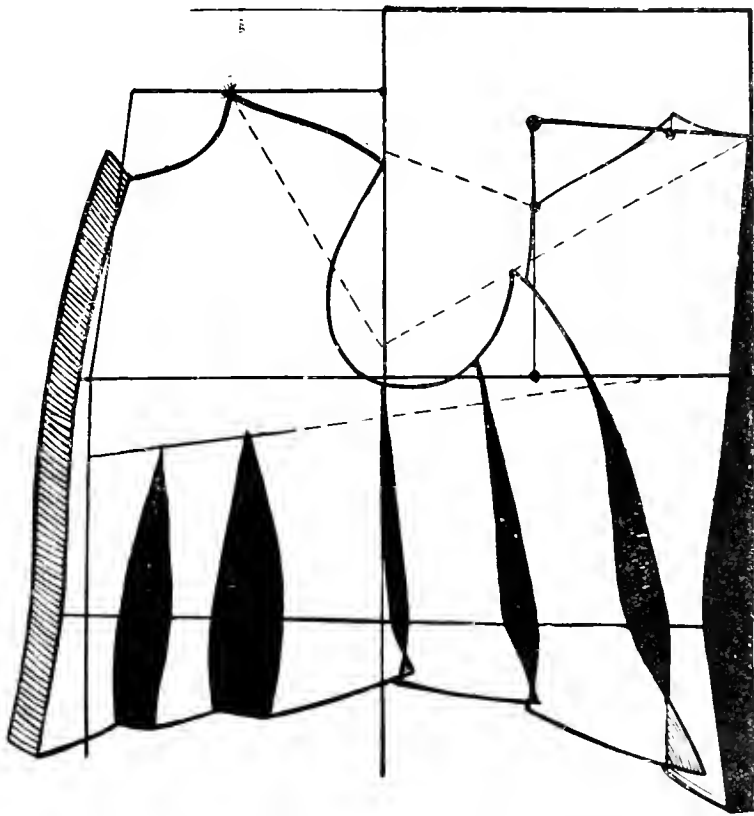

OUR SYSTEM OF CUTTING.

The all-important question to be decided by every student in search of a system for garment cutting is, *which is the best system taught?*

He is met on the very threshold by the clamorous multitude of system teachers, all claiming, "*par excellence*," for their respective systems, which so confuses and perplexes him that, in despair, he is inclined to give up the search and denounce "the whole race."

In all "callings" as well as in theology there are "true as well as false teachers," and in many cases it is difficult to decide between them. But we must remember that, because there are "false teachers" is no sufficient reason to denounce *all*. In all things we must discriminate, and, to a large degree, frame our judgment upon what we believe the most reliable evidence offered for our consideration, and not allow ourselves to be attracted as are the swarming bees by the din and clatter of noisy bells, tin horns, etc.

While this is true regarding things in general, it is particularly true of all who are in search of a system.

We should not be allured by the one making the loudest outcry—"a barking dog never bites." You can apply the moral.

You should act calmly and only after searching investigation. One of the surest tests of anything is *the result*—a pudding's worth can only be decided by eating of it—a system's worth can only be known by the standard and standing of its scholars. This is meant in a general sense, for you will admit that there are exceptions to all rules, and it is impossible for professors to impart *brains* where none exist; hence a good system is occasionally condemned when, in fact, the fault is to be attributed to the want of artistic ability on the part of the student.

Cutters who are unsuccessful in their profession invariably attribute their failure to the system learned by them. Inquiry establishes the fact that, instead of the system being at fault, nine times out of ten it is the man himself.

Incompetency and lack of ability only are the causes of his failure.

As a rule most of the systems have some good points—many are defective a few are good, and none perfect; therefore, the object is to find the one as near perfection as possible; and the best and surest way to judge of this is to definitely settle in your mind which system gives the greatest satisfaction in the most cases, and is most generally endorsed by the successful cutters.

In such a search, and by an unprejudiced person, the Tailors' and Cutters' Exchange have no fear of being passed by, being confident that the system of cutting as taught by Dittmar & Sheifer presents points of excellence offered by few if any other system, and its endorsement by the most skilled cutters of this city is sufficient guarantee of its excellence without our entering into long columns of praise and laudation of its merits.

But, for the benefit of those who may not be acquainted with the workings of this system, and the better to allow them to judge of its qualities, we will briefly mention its chief attractive points, viz., simplicity, reliability, and swiftness of execution.

## THE TAILORS' & CUTTERS' EXCHANGE

The Tailors' and Cutters' Exchange, who are the publishers of this work, has been established for a number of years, and has always been held in high esteem by all who have become acquainted with its merits. It has had a steady and prosperous growth from its birth, and has always maintained its name for integrity and true worth.

No loud-mouthed trumpets of brass have been engaged to sound its praise or proclaim its virtues, but it has gradually and quietly worked its way up from a small beginning until now it is an acknowledged power in the land, and its friends and patrons are to be found in all sections of this extensive country. Our students are from every State in the Union and Canadas, and its graduates are to be found scattered all over the land. Among the faculty and members of "The Exchange" will be found some of the best-known tailors and cutters of this city and country, and our magazine and its illustrations will be under their surveillance; consequently the public can rely upon always having the newest designs and most approved styles, emanating from the acknowledged leaders of style and fashion.

We have many advantages for the truthful portrayal of fashions over all of our competitors; their boasts to the contrary notwithstanding. But of this we will say no more, as we prefer to have the interested public judge for themselves and choose between us, feeling assured that our works and their superiority will speak for themselves.

## THE POWER OF MEMORY.

A correspondent of *Nature* tells a curious story of an American waiter at the New York Fifth Avenue Hotel, who can take charge of five hundred hats at once, and always return the right hat to the owner, though most of the

five hundred owners, and, of course, most of their hats, are completely strange to him.

This waiter says that he "forms a mental picture of the owner's face inside of the hat, and that on looking at any hat the wearer's face is instantly brought before his mind's eye." Here, then, if the account be accurate, is another case of a memory indefinitely strengthened by a power of visualizing impressions which most men never visualize at all. This man visualizes hats with faces under them, as great chess players who play without the board visualize the pieces set in particular squares; only this is a more remarkable exercise of the same power, since five hundred hats must contain many nearly exact copies of each other, while none of the sixty-four squares on a chess-board need be confused together at all by any one who can make himself any accurate picture of them.

While this may appear "fishy," there is more truth in it than a casual reader will give credit. We will not maintain that it is "the whole truth and nothing but the truth," but we believe that to a certain extent it is true. Some men possess remarkable faculties for connecting objects. We occasionally meet men who immediately recall the name of a person upon seeing his face; others associate places of residence with the face, etc.

But what we wish to impress upon our readers by the above is, that it is a good thing for all cutters to *cultivate* this faculty. It is well to acquire the habit of *photographing* the shapes, styles, etc., of their customers. By some device they should learn to impress indelibly upon their minds an exact counterpart of the various customers they measure; they should so study this subject that by "looking over their man" they could produce, as it were, a *facsimile* of him upon paper by simply associating the measures taken with certain "points" they have noted down in their mind.

We are positive *this is a faculty* that can be cultivated to advantage by every cutter, and we think it is his *duty* to cultivate it, for by so doing he fosters and gives life to an element which goes far towards helping him to successfully draft his patterns so as to overcome the various defects which may exist in his customer and his system for cutting.

## THE DIGNITY OF TAILORING.

A great number of persons are disposed to deride the calling of a tailor, and many young men may be deterred from learning the trade on this account. If any such should read this article, let them remember that tailors stand about as high, as a profession, as any other, as proven by the difficulty of making a good tailor out of a lawyer, while many tailors have proved successful lawyers and surpassed as counselors, and a few have made able statesmen. Of the latter, President Andrew Johnson, whatever may have been thought by some of his policy, it has been frequently acknowledged by many able men since his death that his state papers are the most correct and able of any since the days of Thomas Jefferson.

But, after all, who of modern tailors are justly entitled to the tribute paid to the memory of Pasquin, the Roman tailor, who was regarded as the wittiest man in Rome, and after his death, two thousand years ago, they raised a marble monument in Rome to his memory, which remains to this day in nearly the centre of the city? No one, unless it be Andrew Johnson. It is true that very many tailors have been Lord Mayors of London, and Baron Stults was not only an excellent tailor, but he improved the dyes and tints of cloths, and invented the best factory for making superior cloths of any one in England.

Nine journeymen tailors once made a very wealthy merchant, who had lettered on the panel of his coach, "Nine tailors made the man." This was done in honor of the noble members of the craft who had made his fortune by donations to establish him in business. But by the conceptions of the following age, when literary scamps found it impossible to get credit with the tailor, they turned the compliment into blackguardism by rendering it thus: "It takes nine tailors to make a man." Even Shakespeare was not free from the taint, as shown in some of his plays, in which he endeavored to disgrace the tailor. It is an honorable calling, and no one should blush with shame for being numbered among its members.

## A WORD TO CUTTERS AND TAILORS.

Life indeed is short, and the few years we are permitted to live should not be one-sided — in a word, we should live in a measure for others as well as for ourselves. This should be the aim and life-work of a good tailor or cutter. The tailor should not wait until after years on the bench have passed to begin to learn cutting, for then, constantly in a cramped condition when his limbs are supple, he will find them, in old age, shaky and so enfeebled as not to be able to stand for any given length of time. A young man begins and learns cutting thoroughly, and, thereafter, all other branches of the profession become easy and pleasurable tasks. One of the best cutters and tailors in the profession came to our Academy the other day and applied for a situation, which was speedily obtained for him in one of the leading custom establishments in the city, and you can imagine our surprise when he again visited us, in a few days, saying that he was obliged to leave his situation owing to the feebleness of his legs; that it was physically impossible for him to stand any considerable length of time. This is an illustration which should convey its lesson to every cutter especially, for, this man, after many years an expert tailor, became, in the same degree, a cutter, but in his old days was practically useless as such. So begin cutting when young and you will have in your old age a profession that will prove a blessing to yourself especially, and to those who may have to depend upon you. Now your especial attention is called to the fact that it is not by any means an edifying sight to see a cutter on his knees measuring a customer for length of garment, and we make it an invariable rule to instil into the mind of the student never to kneel, but in every instance if they have not a platform in the establishment in which they may be employed, to procure a box and drape same with carpet or any other suitable material and let their customers stand thereon, and thus they will add a little ray of lustre to the profession, and, among other things, it will materially help them to obtain a correct measure.

## Plate 1.

## THE MEASUREMENTS

ON LADIES' GARMENTS,

BY

DITTMAR &amp; SHEIFER'S

## Self-Balancing System of Cutting

TO BE TAKEN OVER THE WAIST.

The measure ought to be taken with ease and dispatch, and it has a bad appearance to be moving around your customer; placing yourself behind him, you can do all the measurement without change of position. It is of great importance that your customer should not assume a forced or unnatural position; to avoid this difficulty, address them on some subject to attract their attention. Be also very careful, in measuring, to place the measure close to the body, neither tight, loose, nor crooked. Apply the measure around the arm with your finger, in order to bring the looseness of the waist close to the body; take all of the same tightness, and those from the socket bone without departing from it.

The success of a garment depends greatly on the balance which the measurement can ascertain. However, it must not be lost sight of that the human body is not a statue, and that the greatest care to seize the opportunity of having it in its natural position is of the greatest importance. It is not unusual that persons having a stooping attitude, erect themselves when they are to be measured. Take notice of it, and add, say  $\frac{1}{2}$ , or  $\frac{1}{4}$  inch on the nape measure according to your remark on their forced attitude, and all these points will locate themselves.

27. A brass belt should be used in all cases, when measuring a customer, in order to get the correct measurements of around and length of waist, balance measure, etc.

On placing the belt around the customer's waist, take hold of the belt with the buckle in your right hand; then place your belt around

the waist catching the belt with the left hand. Now place the other end of the belt in the buckle drawing it tight with the left hand to suit customer; after doing this fasten catch which you will find in end of belt.

Belts can be had of Dittmar & Sheifer from \$1.50 up, according to sizes. Sizes run from 30 to 50 inches.

**A.** Take position behind the customer for measuring. Make a mark on the socket bone, point A.—See Fig. 1.

**B.** Make a mark at the centre of back level with depth of arm hole. You may place a straight line from the depth of arm to the centre of back, point B.—See Fig. 1.

**1.** Blade measure from point A, over the shoulder, around the arm. See that your measure be placed in good order and close to the Arm, and coming to the centre of the back, say 22 $\frac{1}{2}$  inches.—See Fig. 1.

**2.** Nape measure from point A to B, say 7 $\frac{1}{4}$  inches.—See Fig. 1.

**3.** Length of waist from point A, say 16 inches.—See Fig. 1.

**4.** Total length of garment according to style of garment.

**5.** Width of shoulder from point A to the top of shoulder bone, say 7 $\frac{1}{2}$  inches.—See Fig. 1.

**6.** Depth of arm hole. Place a pencil or any other straight line under the arm. Take depth of arm-hole from point A to the depth of arm, say 11 $\frac{1}{2}$  inches.—See Fig. 2.

**7.** Front balance from point A over the shoulder straight down to front centre of waist, say 20 inches.—See Fig. 2.

**8.** Length of sleeves, from point A on socket bone over the shoulder, in front of arm down to the wrist, say 29 inches.—See Fig. 2.

**9.** Bust. Over the largest part of the chest and over the blade, say 36 inches.

**10.** Around waist, say 24 inches.

**11.** Hip. 4 inches below waist, say 38 inches.

**12.** Seat. About 8 inches below waist, say 46 inches.

FULL MEASUREMENT.

22 $\frac{1}{2}$ —7 $\frac{1}{4}$ —16—7 $\frac{1}{2}$ —11 $\frac{1}{2}$ —20—28—36—24—38—46

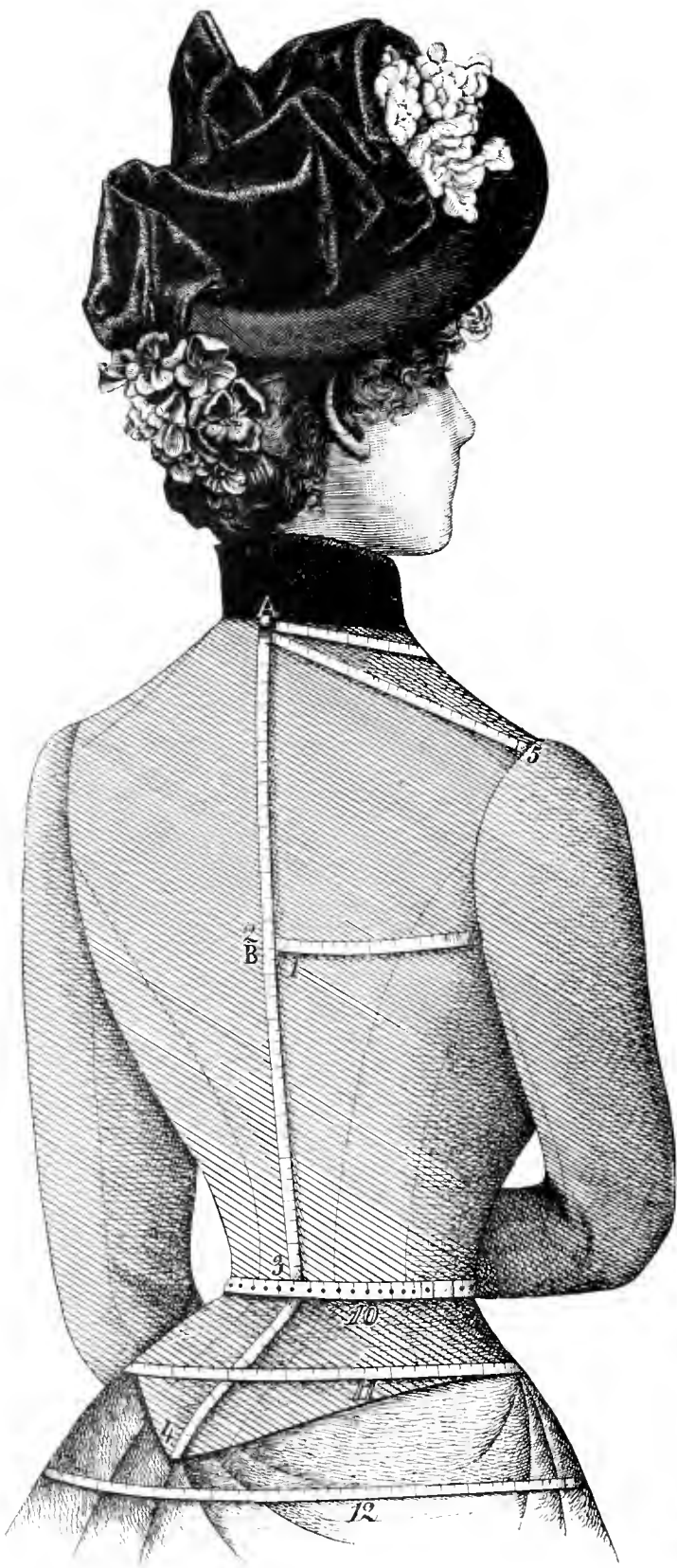

Fig 1.

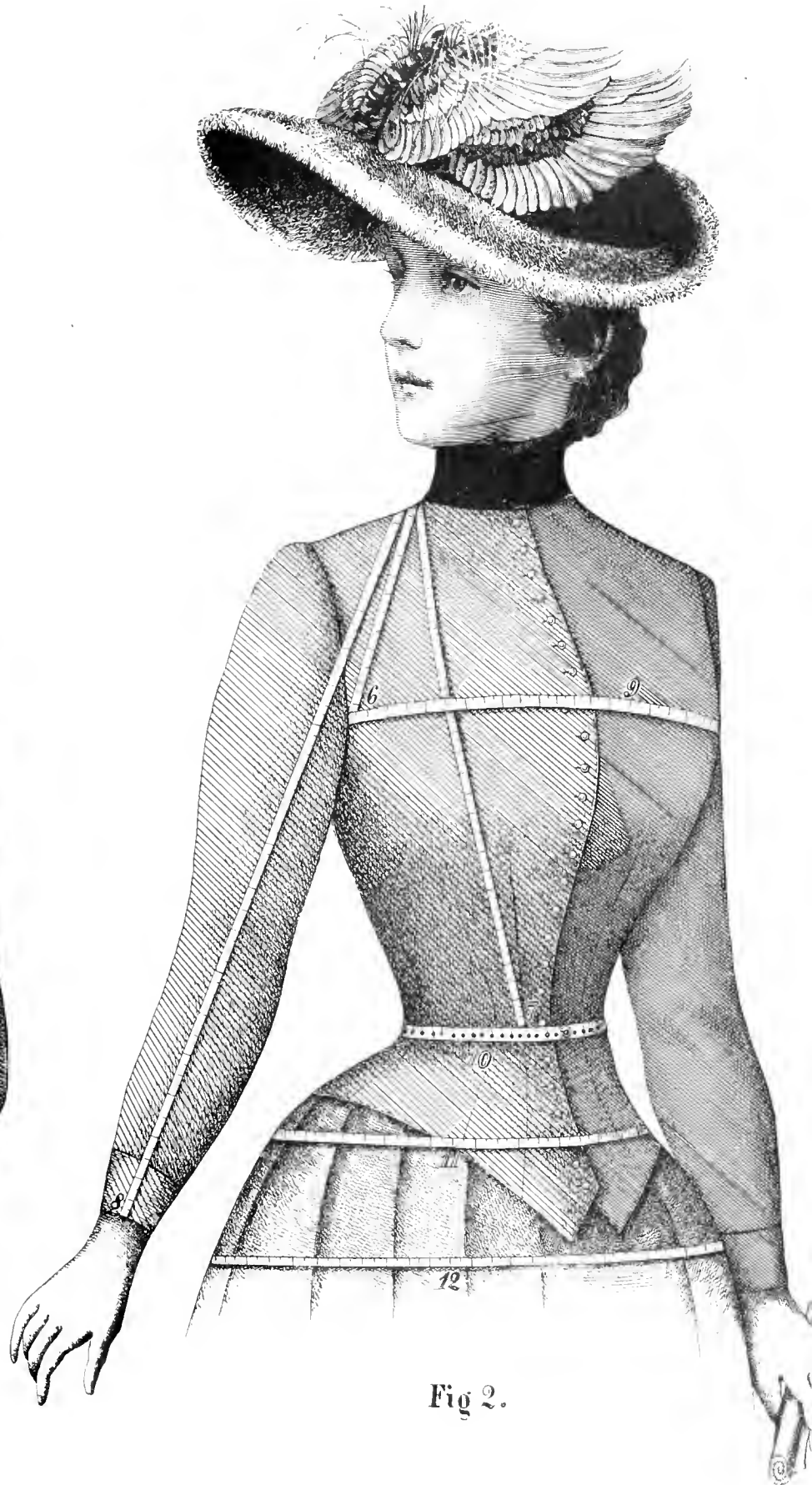

Fig 2.

**Plate 2.****DRAFTING THE OUTLINES.**

THE OUTLINES OF A LADIES' GARMENT WHATEVER IT  
MAY BE.

This is the foundation of the garment by drafting after Dittmar & Sheifer's Self-Balancing System of Cutting Ladies' Garments.

**MEASUREMENTS.**

Blade, . . . . .	22 $\frac{1}{2}$	Front Balance, . . . . .	20
Nape, . . . . .	7 $\frac{1}{4}$	Length of Sleeve, . . . . .	29
Length of Waist, . . . . .	16	Bust, . . . . .	36
Total Length, . . . . .		Waist, . . . . .	24
Width of Shoulder, . . . . .	7 $\frac{1}{2}$	Hip, . . . . .	35
Depth of Arm, . . . . .	11 $\frac{1}{2}$	Seat, . . . . .	40

1. Draw a line on bottom edge of paper.
2. Square line 2 by line 1. See your line 2 to be perfect, squared with line 1.
3. Blade measure (1st measure) 22 $\frac{1}{2}$  inches. Apply 22 $\frac{1}{2}$  on scale No. 1, from line 1 to 3, draw central line.
4. Depth of arm 11 $\frac{1}{2}$  inches (6th measure). Apply 11 $\frac{1}{2}$  inches from line 2 to 4. Square line up.
5. Nape measure (second measure) 7 $\frac{1}{4}$  inches. Apply 7 $\frac{1}{4}$  inches from line 4 to 5 on line 1.
6. Length of waist (3d measure) 16 inches. Apply 16 inches from point 5 to 6 on line 1.
7. 1 $\frac{1}{2}$  inches from point 6 to 7.
8. Draw a line from points 5 to 7.
9. Square a line up by line 8.
10. Width of shoulder (5th measure) 7 $\frac{1}{2}$  inches. Apply 7 $\frac{1}{2}$  inches from point 5 to 10 on line 6.
11. Blade measure (1st measure) 22 $\frac{1}{2}$  inches. Apply 22 $\frac{1}{2}$  on scale No. 2 from line 3 to 11 on line 4. Draw a line from 10 to 11.
12. Measure the distance from point 10 to 11, and take the third part of the said distance from 10 to 12.

13. In the centre between point 11 and 12.

14. Measure the distance between line 3 and point 11 (say 5 inches), take the same 5 on scale No 3 from point 5 on line 9.

15. From line 2 to 15 the same as there is from 5 to 14. Square line up by line 3.

16. Blade measure (1st measure) 22 $\frac{1}{2}$  inches. Placing X on line 2. Apply 22 $\frac{1}{2}$  on scale, No. 2, on line 3.

17. Draw a line by point 16 to point 5, then square a line by point 16 up to point 17. This locates the neck shoulder point.

18. Bust measure (9th measure) 36 inches. Apply half from line 8 to 18 on line 4.

19. Allowance for seams, according to thickness of material and seams preferred, from 2 to 3 inches from point 18 to 19. Draw line down squared by line 4.

20. Measure the distance from line 3 to point 18, say 7 inches. Apply 7 on scale No. 3 to X from point 17 to 20 on line 15. Draw a line from 20 to 19.

21. Measure the distance from point 20 to 19 and apply the third part of the distance from 20 to 21. Now draw a line from 21 to 15.

22. Front balance (7th measure) 20 inches. Apply 20 inches from line 2 to 22 on line 19. Now draw a line from point 7 to 22. This line gives the natural waist.

23. Measure the distance from point 19 to 22 and apply the third of the distance from 19 to 23 on line 19. Now place your ruler on point 23 adjoining lines 1 and 4, and draw a line from point 23 to about line 3. This line gives you the height of darts.

The above shows the perfectability of our measurement system and the corresponding result of the drafting which the attentive student can rely upon as perfect guide to all the various forms.

In drafting any pattern of any measure you draft in the same way. You will find the like result of the above which is a certain proof of the correctness of our Self-Balancing System.

Drafting the garment see next page.



# Plate 2.

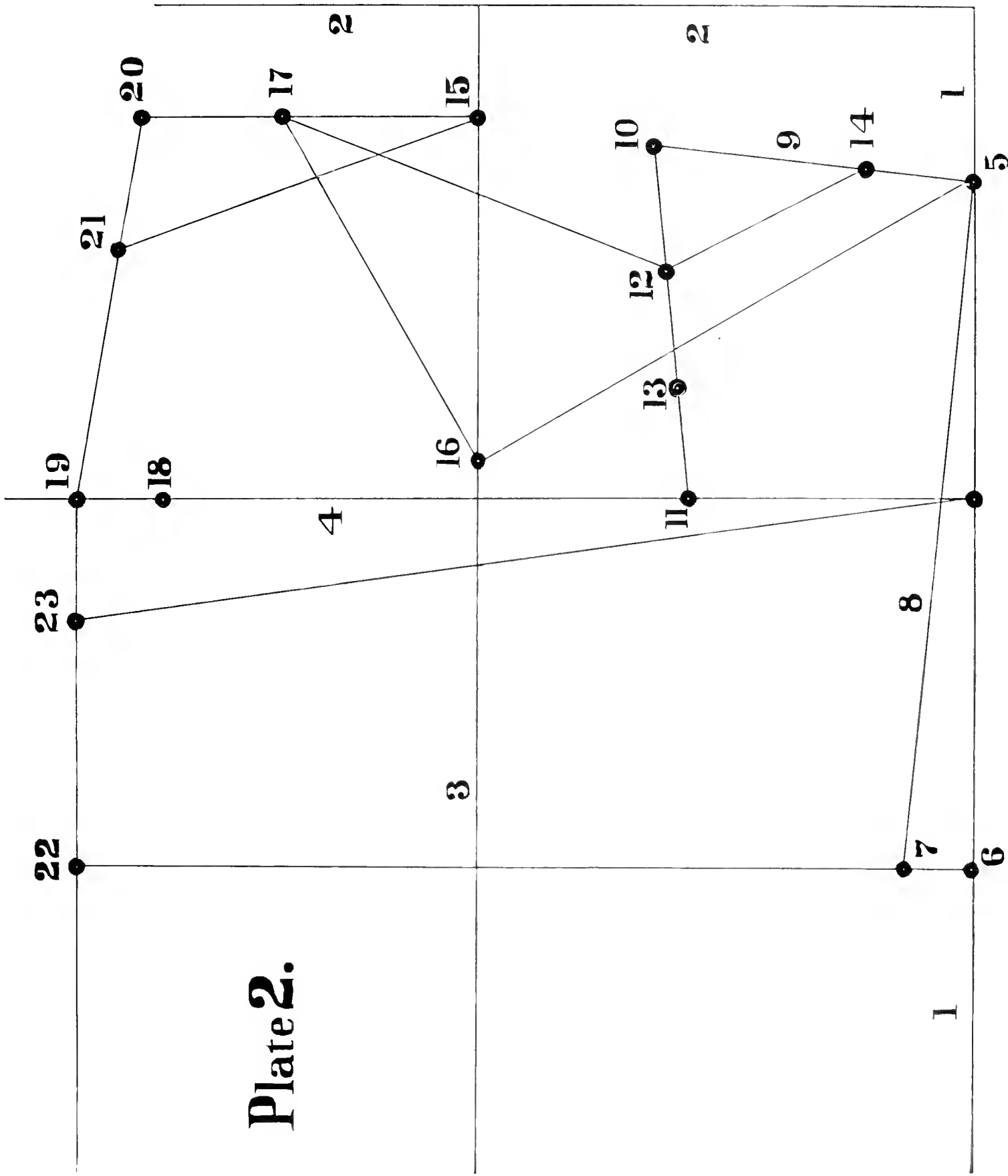

**Plate 3.****DRAFTING A GARMENT.**

BY THE SELF-BALANCING SYSTEM.

**A.** Width of shoulder according to style and taste, about  $\frac{1}{4}$  inch from point 12.

**B.** Width of back from 2 to 2 $\frac{1}{2}$  inches.

**C.** 1 $\frac{1}{2}$  inches from B to C.

**D.** Side body on line 3.

**E.** In the centre, between D and C, take out  $\frac{3}{4}$  of an inch (these three parts). Side bodies and back must have the fourth part of waist, (6 inches) allowing for seams on waist.

**F.** 1 $\frac{1}{2}$  inches from line 3 for arm-hole. Make front shoulder same length as back.

**G.**  $\frac{1}{2}$  inch from line 3.

**H.** In the centre between point 23, and line 3, draw a line down from point H.

**I.** Measure from point 22 to G, deduct the fourth part of waist measure (6 inches) and take out balance on front dart. Make allowance for seams.

**K.** Seven inches below waist allow one inch up from straight line; now draw a line from point 22, this gives the spring of the garment below waist on the front.

This line should be continued for spring of long garments.

Hip measure is 38. Apply 38 inches 4 inches below waist, make allowance for seams. Seat measure 46 inches. Apply 46 inches 8 inches below waist, making allowance for seams.

These two measures can be applied after the draft is finished; should your draft measure more than hip and seat calls for, you can break off equally on each part, or if the same measures less, you must allow the same way equally on each part so as to correspond with the measurements.

Allow 1 $\frac{1}{2}$  inches on the front for the buttons and holes for single-breasted, and from 2 $\frac{1}{2}$  to 3 $\frac{1}{2}$  inches for double-breasted, according to lap.

**CUTTING OUT THE PATTERN.**

Before you cut out your pattern look it over carefully by running your ruler over the same lines and measuring the different points, it will be easy to correct any mistake while your draft is intact, but after being cut out it will be very difficult to make changes.

In cutting out the pattern it will prove more valuable to cut every part full, so you must in each case trace each side body out first, to do this place a clean paper under your draft, trace first one side body (with a tracing wheel), then after doing this cut it out, being careful to notch it at the waist.

Now trace the other side body and cut it out, not forgetting the notches at the waist.

The back and front can be cut out from your draft.

Notches for sleeves to be placed for forepart  $\frac{1}{4}$  of an inch above bust line, the back notch should be placed at the top and centre of side body.

**IMPORTANCE AFTER CUTTING OUT.**

It is very important for every cutter to put the date, measurements and name of customer on the pattern. For draft of sleeve see next Plate.

**TAILORS' AND CUTTERS' EXCHANGE.**

DITTMAR &amp; SHEIFER, PROPRIETORS.

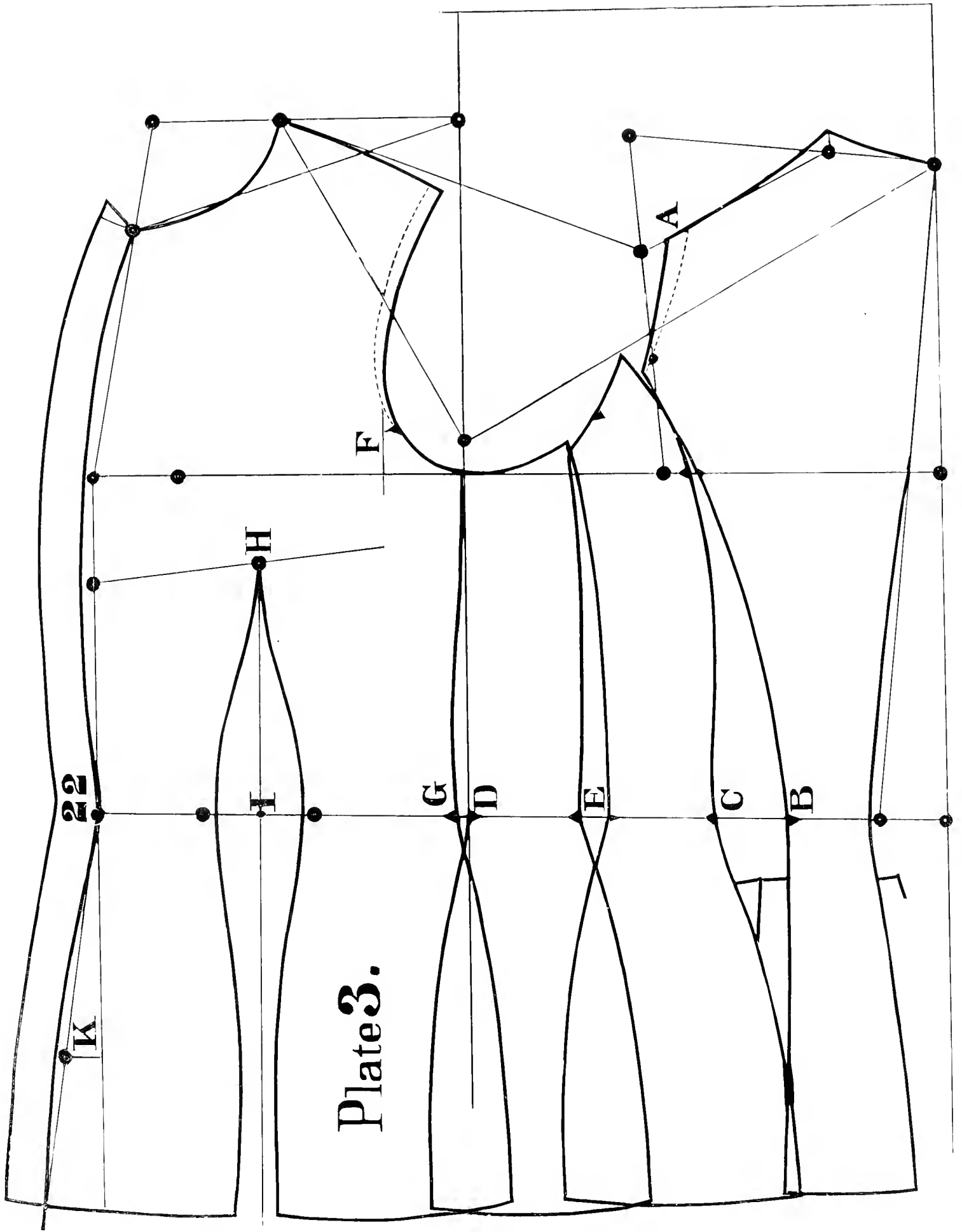

Plate 3.

## Plate 4.

## DRAFTING A SLEEVE.

Measure the top of armhole from notch on forepart to the top of centre of back-side-body, say 11 inches (see Plate 3). Now measure the underarm from notch to notch, say 7 inches (see Plate 3).

1. Draw line 1.
2. Square line 2 by line 1.
3. Toparmholemeasure 11 inches. Apply 11 inches from line 1 to 3.
4. From line 2 to 4, the same distance as there is from point A to notch of side body (see Plate 3).
5. From line 2 to 5, same distance as there is from A to bust line (see Plate 3).
6. In the centre between lines 1 and 3.
7. From line 5 to 7,  $\frac{3}{4}$  of an inch, same as from bust line to notch of forepart (see Plate 3).
8. Underarm measure 7 inches. Apply  $\frac{1}{2}$  inch less ( $6\frac{1}{2}$  inches) from point 7 to 8 on line 4.
9. Sleeve length measure 29 inches, deduct depth of armhole measure ( $11\frac{1}{2}$  inches) and apply the balance of measure from line 5 to 9.
10. In the centre between point 9 and line 5, draw back elbow 1 inch lower.

Bottom of sleeve for plain ordinary style, cut the bottom 1 inch more than the fourth part of bust measure. 36 inches bust, make sleeve 10 inches wide on bottom, allowance extra for seams.

Divide the bottom of sleeve so your under sleeve should be about 2 inches narrower than the upper. Extend both  $\frac{1}{4}$  of an inch forward on bottom. Cut upper sleeve in elbow 1 inch from line 1 and  $3\frac{1}{2}$  inches for under sleeve, hollow the front of sleeve  $1\frac{1}{2}$  inches in elbow.

For plain sleeve with ordinary fullness cut your sleeve up to line 2, for high puff from 3 to 5 inches above line 2 (largest part of puff on line 6).

## DRAFTING THE COLLARS.

Fig. 1. The plain tailor made turn down collar. Draw a line from position you want roll to start from up to the neck-shoulder point. A, 1 inch below for crease of collar. B, from shoulder to B, same as width of the top of the back. Width of collar in back is cut from 3 to  $3\frac{1}{2}$  inches. Width of front collar is cut according to style and taste.

Fig. 2. The Shawl Collar is cut in the same manner as Fig. 1, but about  $2\frac{1}{2}$  inches wider on back, and curve your collar in to the front same as shown on diagram, Fig. 2.

Fig. 3. The Medici Collar. This collar should be cut with a big hollow on back in order that the collar should have plenty of spring on the back of the lady's head.

Fig. 4. The Sailor Collar. Place your back and front together with the shoulder seam, after doing so collar will be very easy to get by the shape of the neck, back, etc. (See diagram Fig. 4.)

Fig. 5. The Standing and common Turn Down Collar. Draw a line, A,  $\frac{3}{4}$  of an inch curve on front. Now apply the neck measure by measuring neck of front and back. The turn down collar is shown on the same, Fig. 5. Allow 1 inch of crease in back and  $\frac{1}{2}$  inch in front.

## SPECIAL NOTICE.

No one, except in this Academy, is authorized to, nor capable of, teaching any of our systems. Gents or ladies and any one undertaking to do so wrongfully and imposes on the trade. We teach our students how to cut, *but we do not teach them how to teach.* The instruction we give a student is given him for his personal use only, and if he teaches another for pay he is morally guilty of a breach of trust, and those interested should not permit themselves to be imposed on.

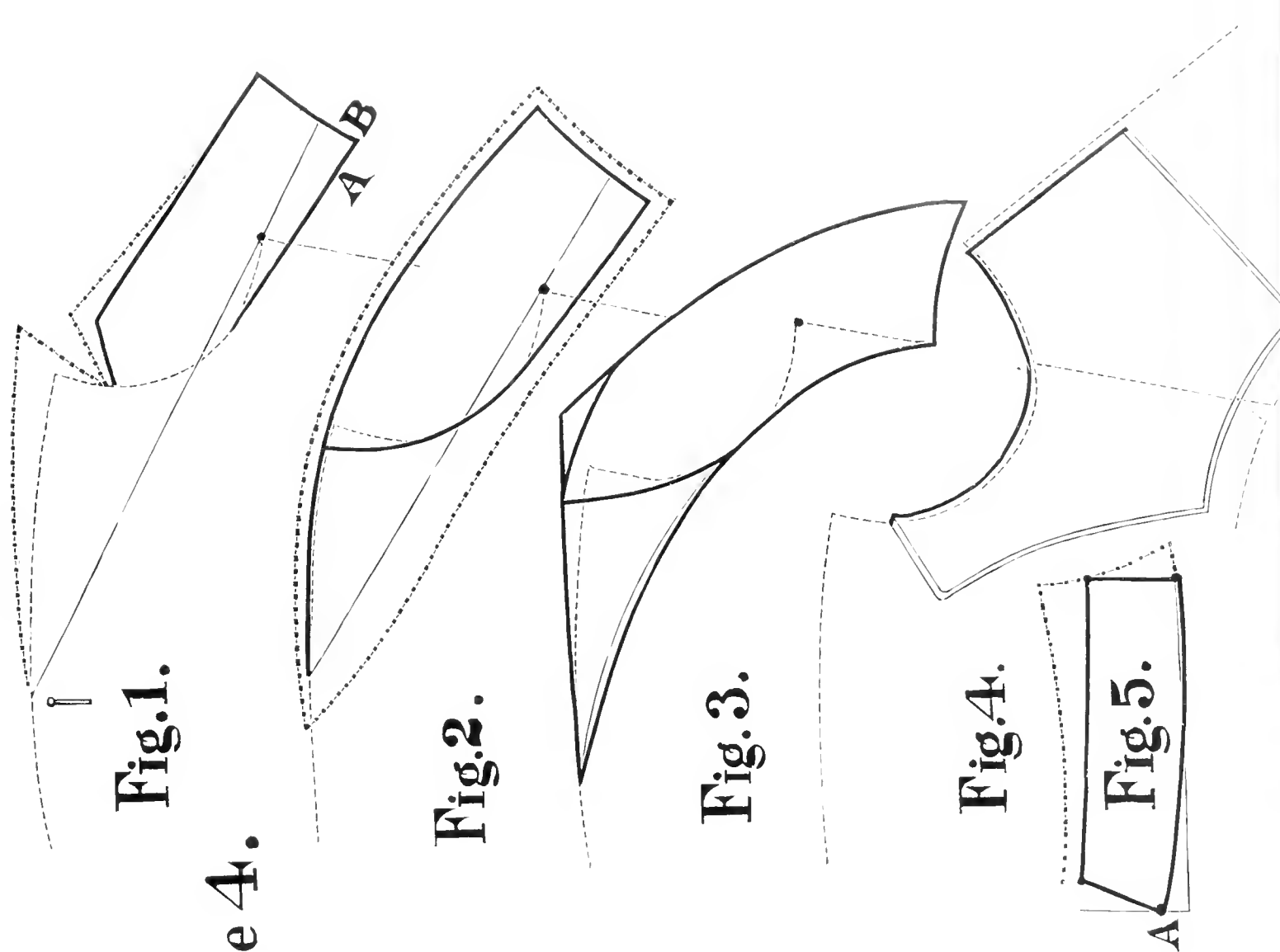
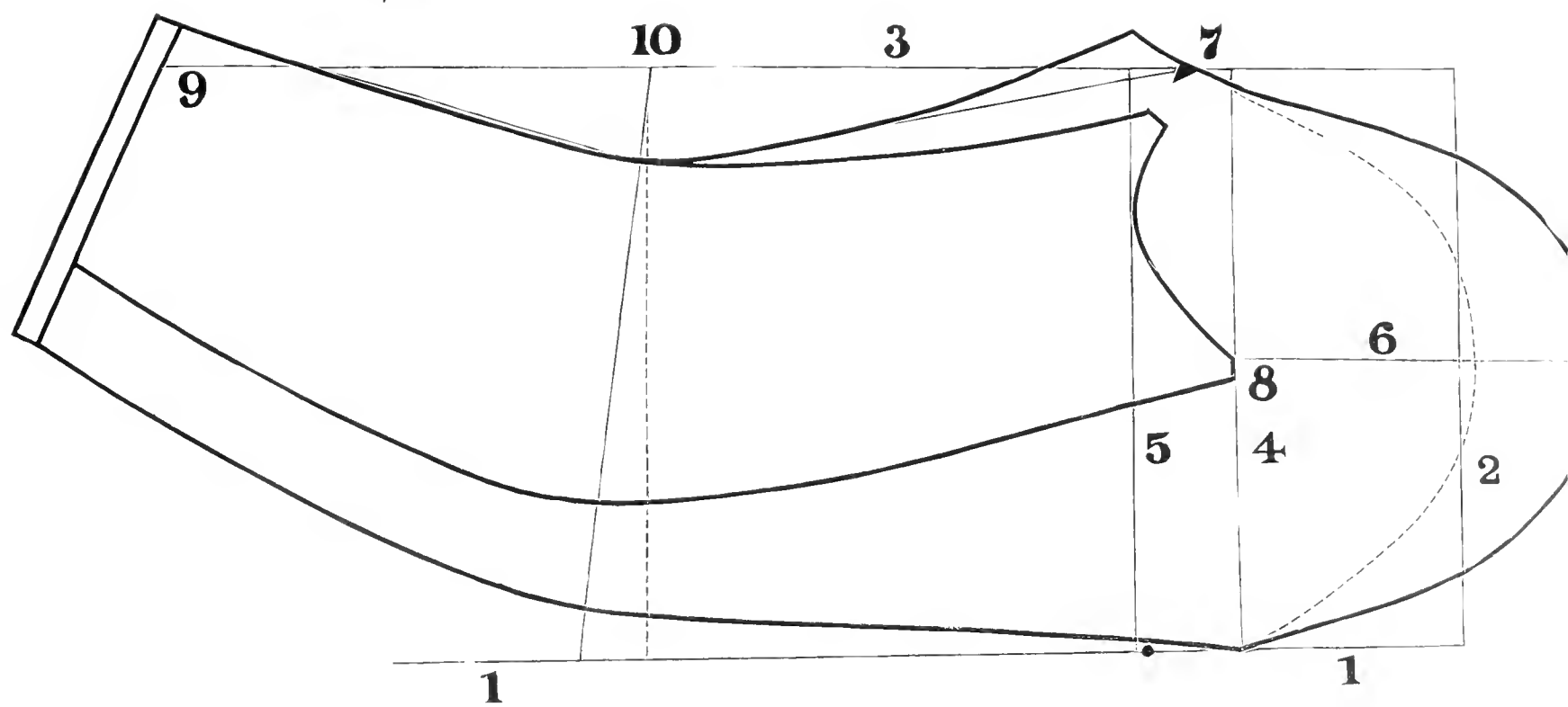

Fig. 1.

Fig. 2.

Fig. 3.

Fig. 4.

Fig. 5.

Plate 4.

**Plate 5.****DRAFTING A LOOSE FRONT GARMENT.**

WITH OR WITHOUT VEST.

Front side body should be cut  $\frac{3}{4}$  of an inch further front than for tight fitting, take out from side to front on waist  $1\frac{1}{4}$  inch. Front from waist up should be cut  $\frac{3}{4}$  of an inch shorter than side body, *this should be done for all loose fronts*, as the front must be stretched in order to smooth out the wrinkles which generally appear on a loose front garment at the waist.

Cutting the front of forepart for a loose and straight front, single or double breasted, see G and Gx on next plate.

**THE VEST.**

Front of vest is cut same as front of Plate 3. Average length of vest, from 5 to 6 inches in front and 2 inches on side. Front dart of vest divide the same as on Plate 3. For vest with full back, see Plate 17.

**THE BEAUTY OF A GARMENT.**

The success of a cutter does not always depend in cases of a smooth fit. We know of some cutters whose garments are always fitting to perfection, but no shape to them at all—this is spoiled by refitting.

The principal we claim in our system is the shape of all curves as well as the fitting. If measurements are taken with care you are sure of a perfect fit; no need of alteration. Therefore your shape and curves will remain as designed in drafting your pattern.

**THE PECUNIARY VALUE OF TASTE.**

In general we have a very inadequate appreciation of the pecuniary value of taste.

Taste measurably supplies a deficiency of means in almost everything.

How often do we see a cheap but tastefully planned and arranged cottage excelling in attractiveness the costly but ill-contrived dwelling!

The difference between taste and the want of it is strikingly manifest in the laying out of grounds and planting trees and shrubs.

It is also manifest in other ways. One person always appears well dressed, another never; yet the one who is ill-dressed may pay his tailor twice as much a year as the other.

One who does not understand the adaption of style and colors may be loaded with costly garments and finery, and yet never appear well dressed.

To some persons taste in everything seems natural, but in all *it admits of cultivation*. And the cultivation of one's taste not only saves money, but it is a source of much satisfaction and happiness.



Plate 5.

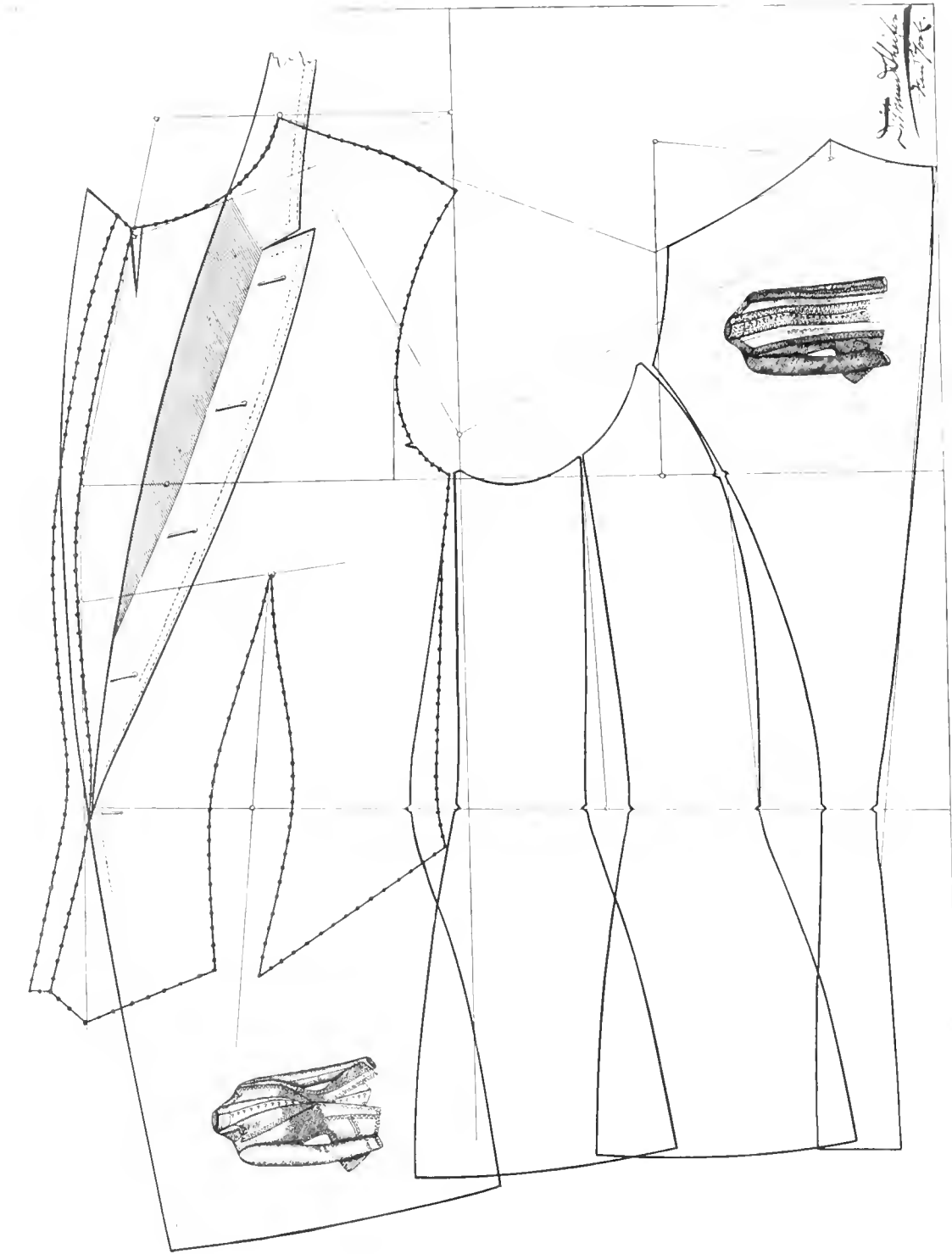

## Plate 6.

## DRAFTING A PLUSH GARMENT.

JACKETS, SACQUES, NEWMARKETS, ETC.

Heavy Cloth Garments Lined are cut in the same way..

**18 to 19** allow 3 inches.**A.** Width of back from 3 to 3 $\frac{1}{2}$  inches.**B.** From A to B 1 $\frac{3}{4}$  inches.**C.** From line 3 1 $\frac{1}{2}$  inches.**D.** Take out 1 $\frac{1}{2}$  inches from C to D.**E.** For armhole 2 $\frac{1}{4}$  inches from line 3.**F.** Neck shoulder point to be placed 1 inch above point 17.**G** and **G X.** In a square  $\frac{1}{2}$  of an inch below point 18.**H.** Allow two inches for ordinary lap of sack; 3 inches for double breasted Jacket or Newmarket. Facing should be allowed on front of garment for all loose fronts (will not work well for tight).

## DRAFTING THE BOTTOM OF A SACK OR NEWMARKET.

**I.** For sack or Newmarket, 1 inch from line 1.**J.** Width of back on bottom the sixth part of bust measure.**K.** Draw side-body in the centre of back on bottom.**L.** Width of side-body for sack the fourth part of bust, and for Newmarket cut the same 1 $\frac{1}{2}$  inches more.**M.** Front for Sack 1 inch from J; for Newmarket run it down to point J. Collar is already given on Plate 4, Fig. 2.

## SPECIAL FOR FURRIERS.



Seal Skin, or other fur garments, of course, does not need the allowance for seams as cloth garments, but  $\frac{1}{8}$  of an inch for each seam should be considered taken in from each part.

The main allowance for skin garments is for the lining, if quilted lining, allowance of 2 inches must be made from points 18 to 19. If plain lining 1 $\frac{1}{2}$  inch is enough. The same allowance should be made on waist and hip. Width of back should be cut  $\frac{1}{2}$  inch narrower. Shoulder must be cut much narrower as for cloth. If tight fitting, two darts should be placed in forepart instead of one. All other points should be done the same as given on Plates 2 and 3.

For cloth garments lined with fur allowance must be made *besides the regular allowance* as follows:

Blade, - - 22 $\frac{1}{2}$ inches.	Bust, - - 36 inches.	Depth of Arm, 11 $\frac{1}{2}$ in.
Allow, - - 1 " "	Allow, - - 2 " "	Allow, - - - 3 $\frac{1}{4}$ " "
Cut, - - 23 $\frac{1}{2}$ " "	Cut - - 38 " "	Cut, - - - 12 $\frac{1}{4}$ " "

Waist, hip and seat should be allowed same as bust.

## OUR SUCCESS WITH FURRIERS.

During the past few years our classes have grown considerably larger with students in that department, learning the art of designing for fur garments; their success cannot be equaled with any other system of cutting, in producing such faultless style and fit of which we hold testimonials.



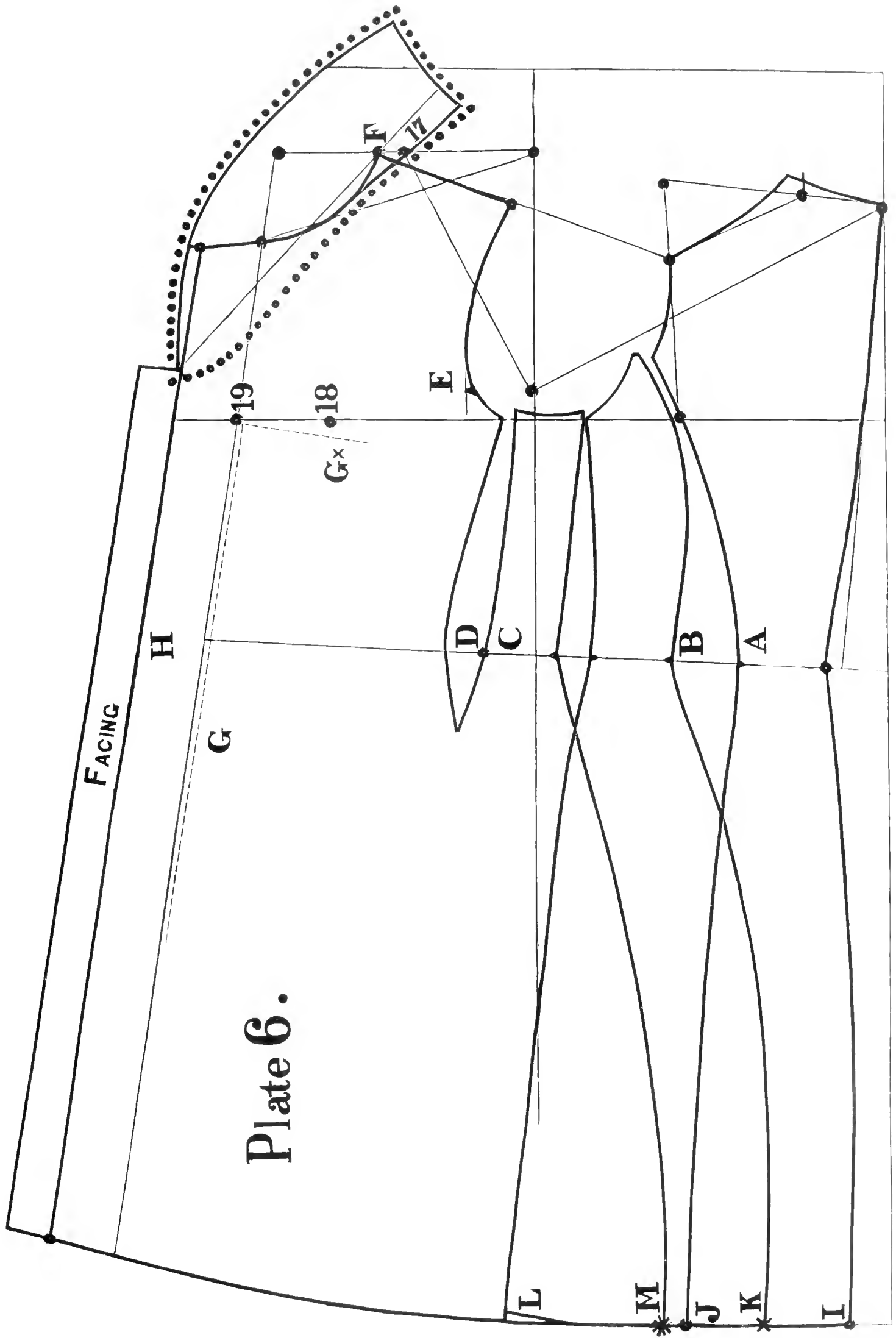

## Plate 7.

## DRAFTING A WRAP.

SHORT OR LONG, JAPANESE OR OTHER SLEEVES.

Fig. 1.

The extra measurements requiring for Wrap Sleeve.

**B.** Elbow measure, from point A (or socket-bone) to the front of elbow, say 16 inches.

**C.** Total length, continue your measurement to the wrist, say 24 inches.



Our supplement of cutting wraps, which has proven the most valuable work invented, and used only by our Mr. Sheifer in his private practice. See Plate 14.

## DRAFTING.

Cut the armhole 2 inches below line 4, bust line. Start back side-body from bust line. Other point same as Plate 3.

**A.** Elbow measure, 16 inches. Apply 16 inches from line 2 to A. Draw line up.

**B.** The eighth part of bust,  $4\frac{1}{2}$  inches, from armhole to line B.

**C.** In the centre between lines B and 3.

**D.** From line B to D, the third part as there is from line C to B.

**E.** Total length of sleeve, 24 inches. Deduct elbow, 16 inches, and apply the balance, 8 inches, from line B to E on line A; this completes the points for top sleeve. Back on waist to be cut from 2 $\frac{1}{2}$  to 3 inches wide, and run it down with one curve from shoulder seam (See Diagram).

## THE JAPANESE SLEEVE.

**F.** From 10 to 12 inches from E to F.

**G.** Under-sleeve 4 inches less as upper.

**H.** According to style and taste about 3 inches, and 2 inches extra for turn up, below waist line.

**X.** Notch for sleeve 1 inch above D, or line 3. Start your under-sleeve from the same point and curve it 1 inch lower in front. See point O.

**I.** Bottom for Japanese under-sleeve 6 inches above bottom of upper-sleeve, also 4 inches narrower in width, as the upper-sleeve should be gathered on bottom in order to form a shape of a curve on bottom of Japanese Sleeve.

**J.** Represents open sleeves on bottom. This is, of course, a matter of taste and style.

**K.** Represents how under-sleeve is cut for open bottom sleeves of all descriptions. Cut your under sleeve for the same about 7 inches wide in front.

Long wraps, such as Dolman, Raglan, etc., sleeve to be cut in the same way. For body see page 18, Plate 6.

Spring wrap may be cut without side body, and elastic band is fastened on waist and under-arm to hold the front in shape. Open bottom sleeve is mostly worn for the same.

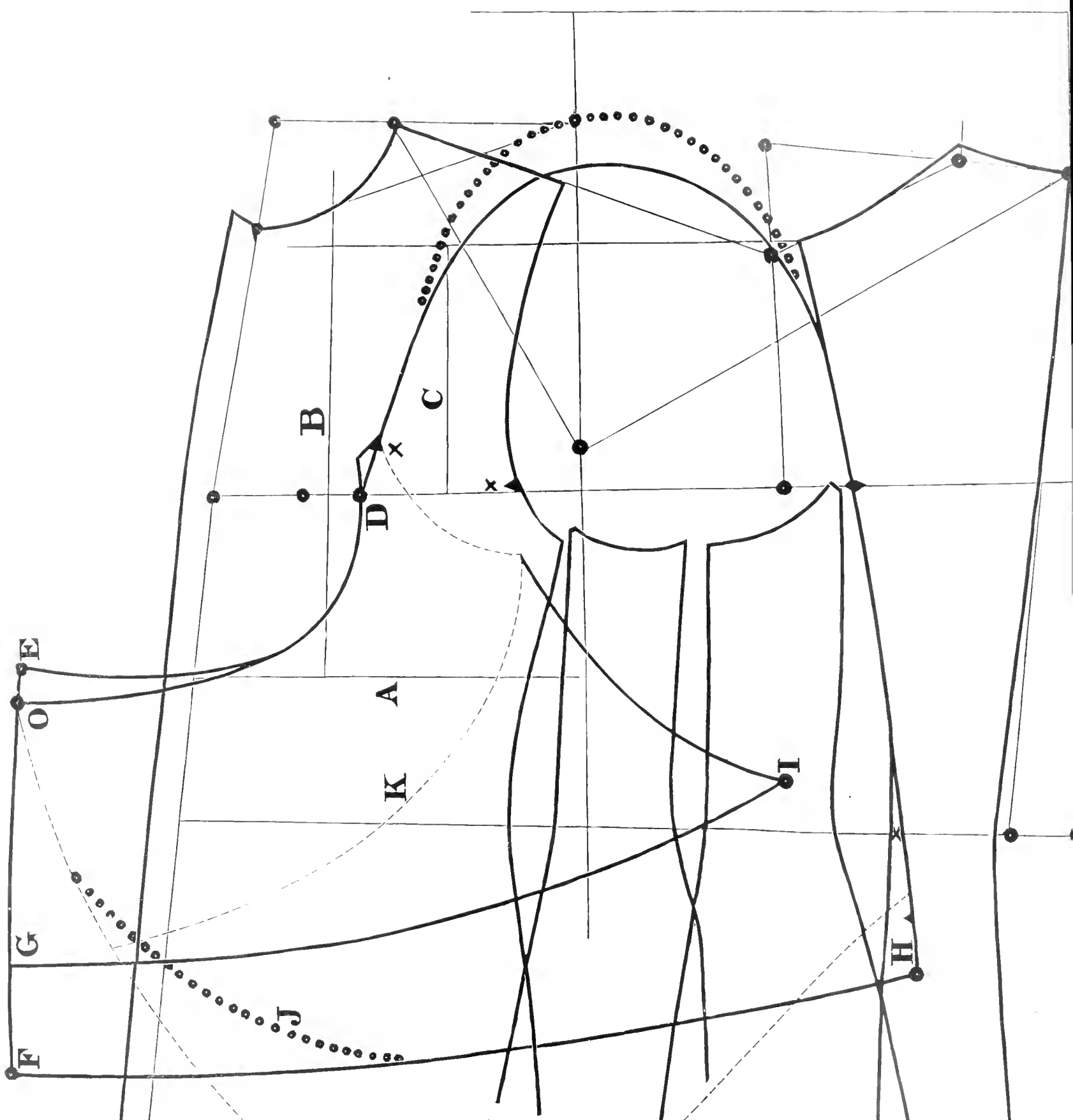

Plate 7.

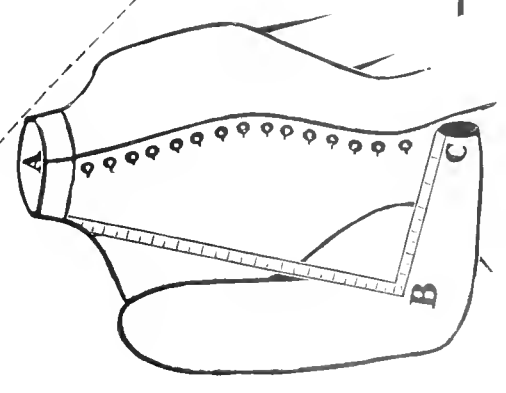

Fig. 1

## Plate 8.

CUTTING THE  
SHOULDER CAPES.

All measurements required for a shoulder cape is bust, neck and length. Drafting a shoulder cape say 36 inch bust, take a 36 inch bust pattern, no difference what style of a garment, all you want is the shape of the shoulders and neck.

## DRAFTING A PLAIN SHOULDER CAPE.

**A.** Draw a line.

**B.** Place your back pattern with top on line and move 2 inches forward in waist.

**D to C.** The eighth part of full bust measure.

**C to E.** Shoulder piece  $1\frac{3}{4}$  inches wide on top.

**O to F.** Shoulder piece  $3\frac{1}{2}$  inches wide on bottom.

**F to G.** 1 inch less as there is from D to C. Now break off from shoulder forepart pattern same as allowed for shoulder piece, from C to E and O to F. Draft your cape as shown on diagram.

By following the rules above for cutting capes, we are taking the pleasure of saying that these rules are on solid foundation, we can assure a perfect fit in all cases. It gives you a perfect shape over the shoulder, balancing your cape straight down in front and back with plenty of room for the arms underneath.

## DRAFTING A HIGH SHOULDER CAPE.

Draw a line up.

**A to B.** Bust measure 36 inches, apply one half of bust and allow the eighth part of bust to it, which makes  $22\frac{1}{2}$  inches from A to B. Now place your back pattern with bust line (or line 4) on point A.

**C.** 1 inch below line. This point can be moved lower if you don't want much puff on sleeve, or can be moved less than 1 inch below line if higher puff is wanted.

Now place your forepart with bust line (or line 4) on point B.

**D.** 1 inch below line. This point should be moved same as point C.

**E.** Allow 1 inch on shoulder of back in order to bring seam of cape more on the centre of shoulder.

**F.** Break off  $\frac{1}{2}$  inch from forepart shoulder.

**G.** 2 inches deep for back seam.

**H.** 4 inches deep for forepart seam.

Now draft cape as shown on diagram.



Plate 8.

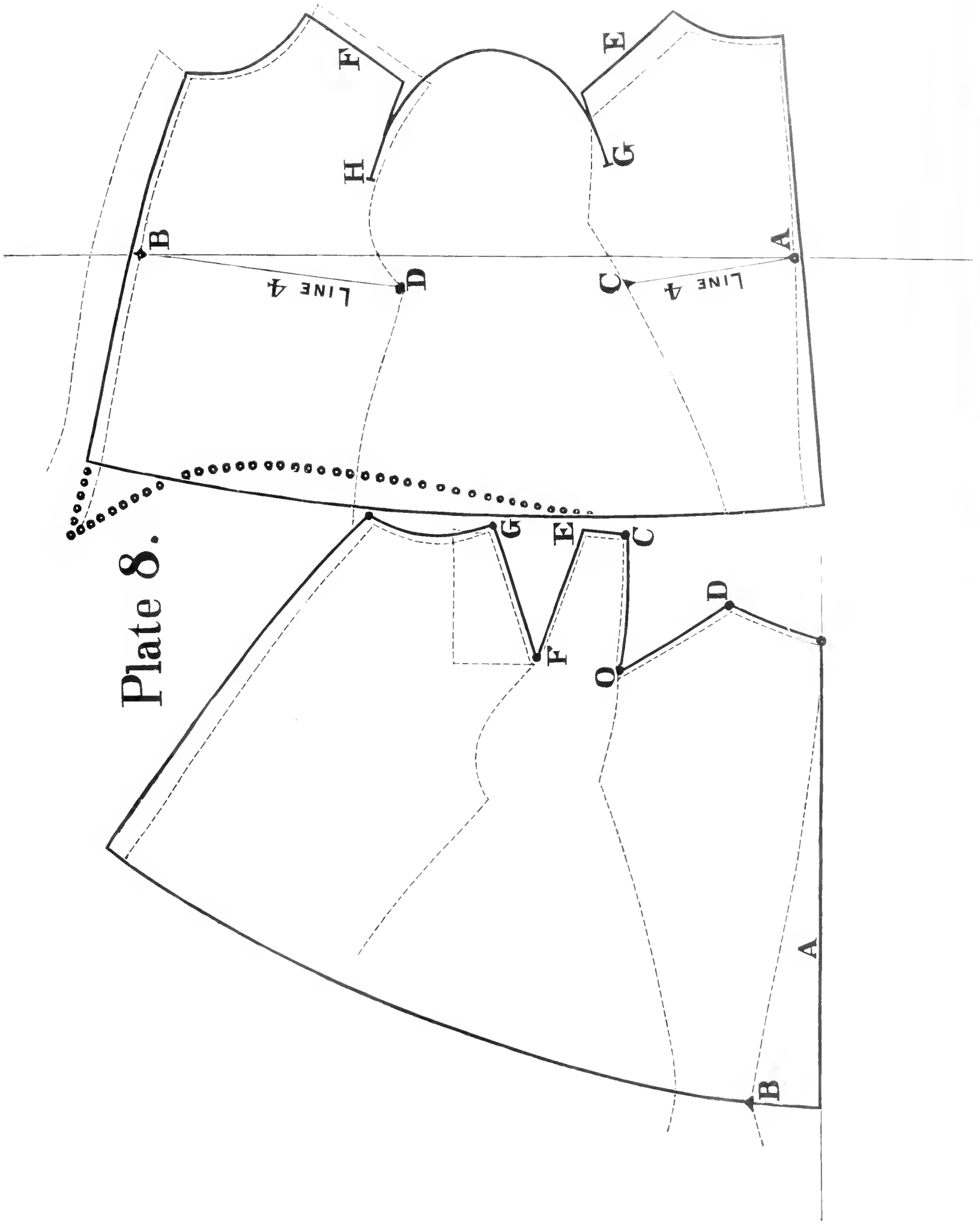

## Plate 9.

## DRAFTING A CIRCULAR.

WITH OR WITHOUT VEST.

**A.** In the centre between back on bust line.

**B** From **X**. The full bust measure, 36 inches, draw a line from A to B, this gives you the spring of cape.

**C.**  $1\frac{1}{4}$  inches above A for notch on cape; the notch must meet in putting the garment together with notch on back with bust line.

**D.** Measure the distance from bust to waist line and apply the same from C to D.

**E.** Measure the distance from waist line to full length of garment, and apply the same from D to E, for length of cape.

Front to be cut same as given on plate 6.



## THE VEST.

(See Darts, -----).

**F.** For front of cape 4 inches from X.

**G.** About 5 inches from F, for lap of cape over vest. Cut the length of side bodies about 3 inches below waist. If vest with sleeve cut your back side up to shoulder seam (see diagram). Other divisions for sides and front dart same as on Plate 3.

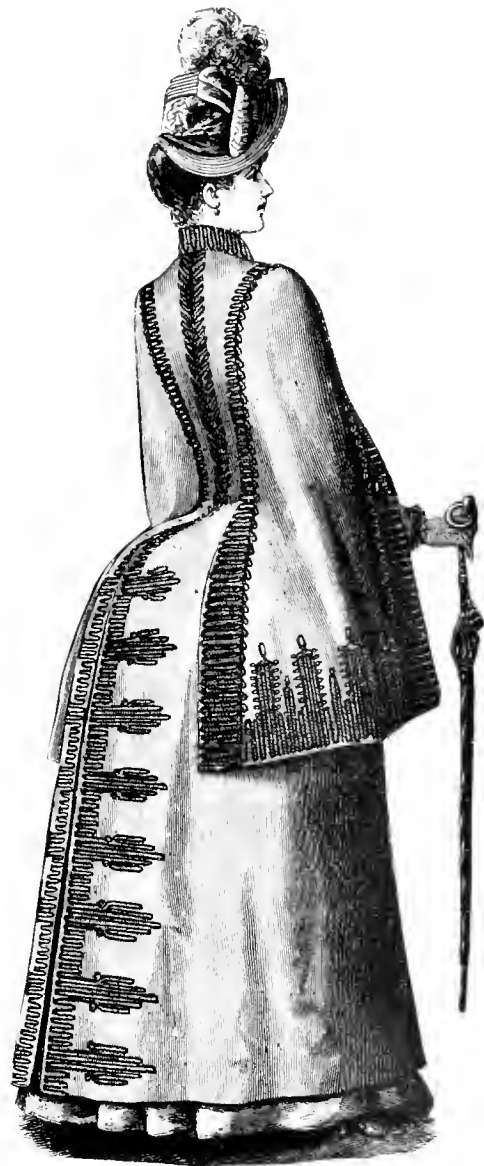

Newmarket with cape combined to be cut in the same rule, bringing side body all away down, as given on Plate 6, and cutting the cape short.

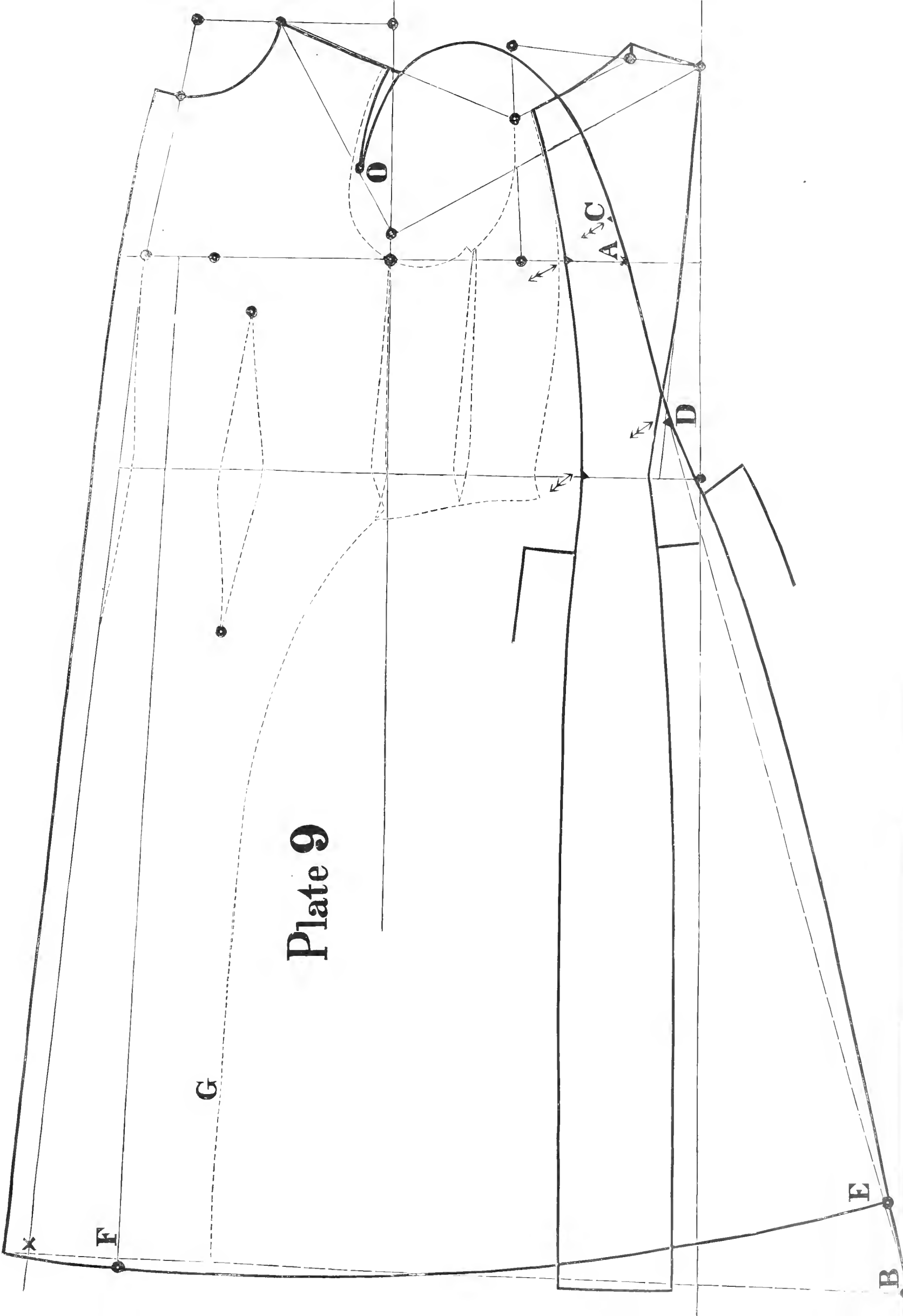

## Plate 10.

## CUTTING THE SKIRT GARMENT.

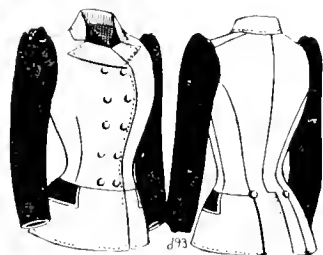

Following the rules given below for cutting a skirt for any garment, either short or long, you will have no trouble at all in fitting the garment on your customer, as the following rules are very simple in its construction and gives best result.

In cutting a skirt garment, cut a plain garment out first with side bodies all away down, measuring the hip, seat, etc., as your measurements calls for.

**A and B.** Place your forepart and side together; lap a seam over each other; begin the seam 4 inches below waist.

**C and D.** Placing back side body together with other side body, same as A and B. After doing this common sense will teach you how skirt is cut. See Diagram.

**E.** For a jacket, commence your skirt 2 $\frac{1}{2}$  inches below waist; for newmarket, 3 inches.

**F.** From 4 $\frac{1}{2}$  to 6 inches below waist. This point is more a matter of taste and style.

**G.** From F to G same as taken out in front dart O.

Front length of skirt same as back.

Make a **V** in skirt straight with front and side seam in order to bring the shape on the hip.

Fig. 1.—This represents how a lapel is cut for double breasted tailor made garment. Cut the same 3 inches wide on bust, 1 $\frac{3}{4}$  inches on waist and from 2 $\frac{1}{2}$  to 3 inches on top.

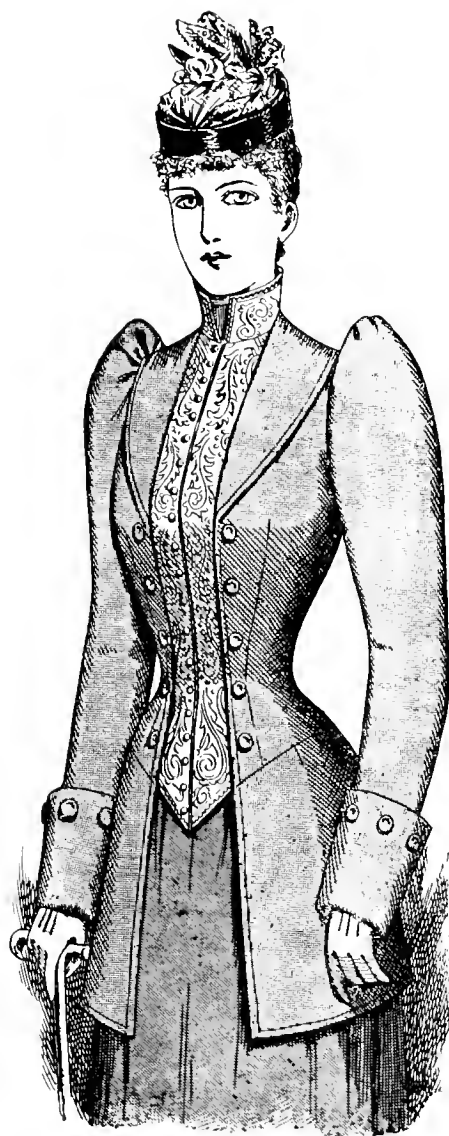



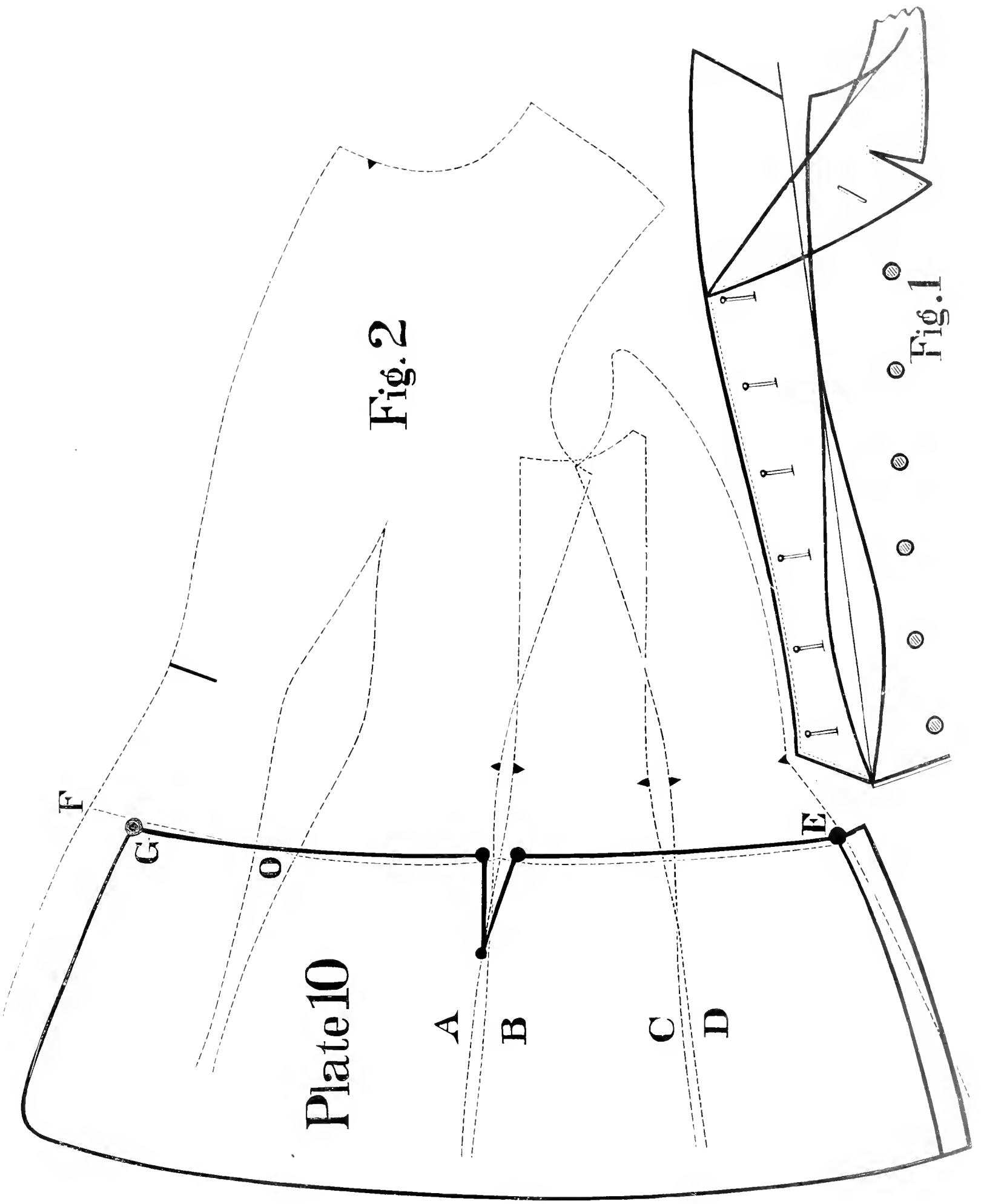

Plate 10

Fig. 2

Fig. 1

**Plate II.**

## THE MEASUREMENTS AND DRAFTING

## OF LADIES' RIDING TROUSERS.

In measuring a lady for trousers let her sit on a chair, as shown in Fig. 1. In order to get rise to the measure. Other measures can be measured while the lady is standing up. Measurements requiring for Ladies' Riding Trousers is as follows :

Waist, say 24 inches ; hip, 6 inches below waist, say 43 inches ; rise, say 12 inches ; lap, say 22 inches ; total length to the sole of foot, say 42 inches. Knee measure may be cut  $\frac{1}{2}$  inch less than the half part of bust. Bottom of trousers may be measured on lady, or you can cut the same  $\frac{1}{2}$  of an inch less than the knee.

## FULL MEASUREMENTS.

Waist,	-	-	-	-	-	24	inches.
Hip,	-	-	-	-	-	43	"
Rise,	-	-	-	-	-	12	"
Lap,	-	-	-	-	-	22	"
Length,	-	-	-	-	-	42	"
Knee,	-	-	-	-	-	16 $\frac{1}{2}$	"
Bottom,	-	-	-	-	-	16	"

## DRAFTING THE TROUSERS.

1. Draw a line.
2. Square line 2 by line 1.
3. Rise measure, 12 inches from 2 to 3.
4. Lap measure, 22 inches from 2 to 4.
5. Length, 42 inches from line 2 to 6.

6. Hip measure, 43 inches. Apply the fourth part from line 1 to 6 on line 3. Square a line from this point and line 3.

7. From point 6 to 7 the third part of the distance as there is from line 1 to 6.

8. Waist measure 24 inches. Apply the fourth part and allow  $1\frac{1}{2}$  inches to it from line 6 to 8.

Central line in the centre between point 7 and line 1.

9. The fourth part of the knee measure from central line.

10. From 9 to 10 one-half of knee measure.

11.  $3\frac{1}{2}$  inches from central line to 11.

12. 7 inches from 11 to 12.

X. From point 6 to X, the half of the distance as there is from 6 to 7.

Now draw front as shown on diagram.

## DRAFTING THE BACK PART.

A. Allow 1 inch above point 7.

B. From line 2 to B, same as there is from central line to 6.

C. From B to C, the fourth part of waist and allow 2 inches.

D. 1 inch from line 1.

E.  $\frac{3}{4}$  of an inch from point 9 to E for seam.

F. From 10 to F, same as from 9 to E.

G. Bottom measure 16 inches. Apply half of the measure and allow  $\frac{3}{4}$  of an inch to it from point 12 to G.

H. From 11 to H, the same as from 12 to G. Now draw back part, as shown on diagram. Cut two V's out in top of back part to fit the waist.

# Plate 11

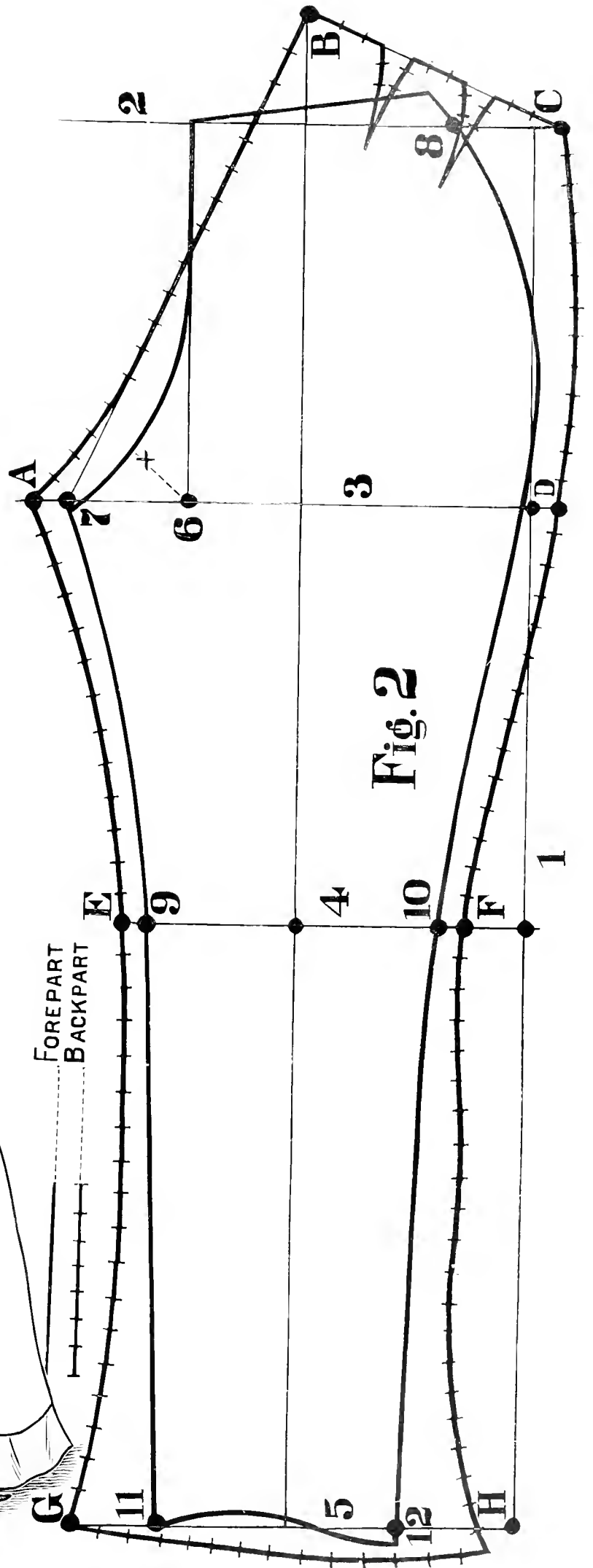
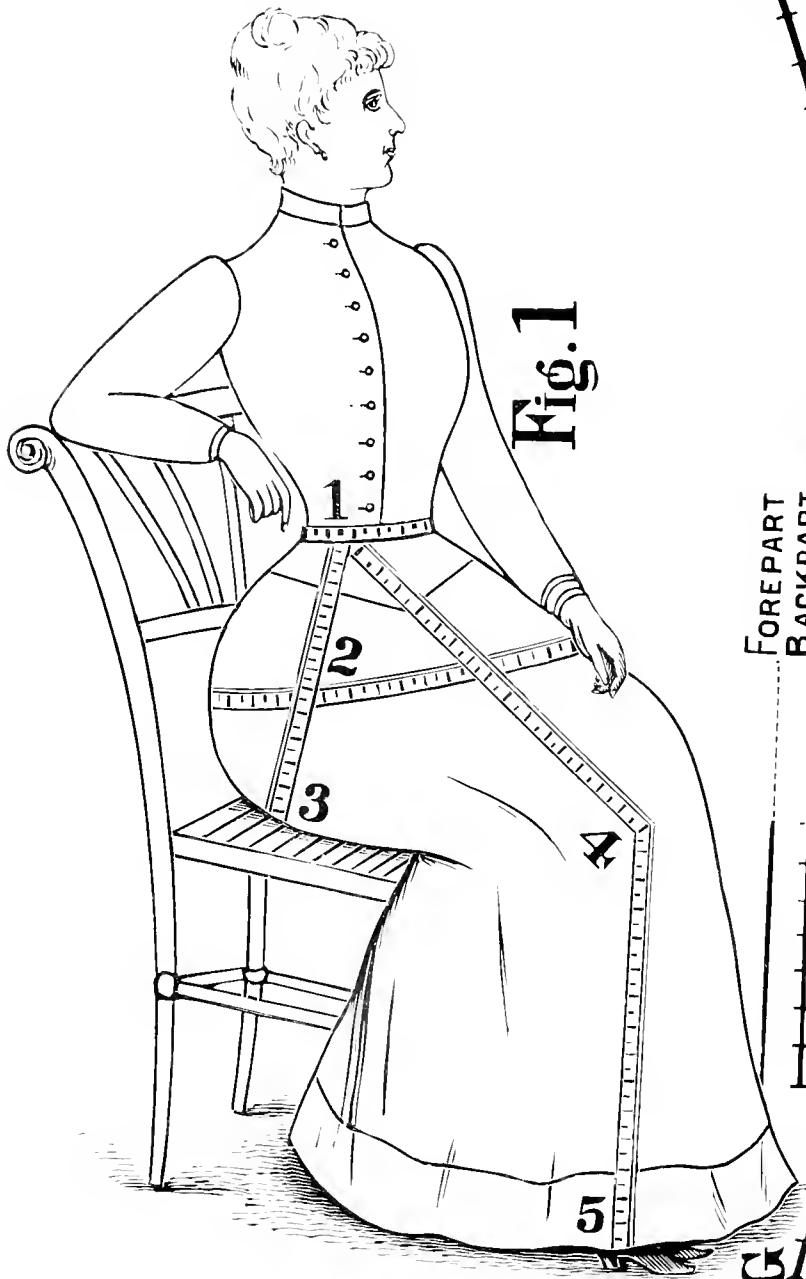

**Plate 12.**

**LADIES' RIDING HABITS.**

The representation of ladies' riding habits are selected from many examined by us, and combine simplicity and elegance. They represent the costumes most generally worn by ladies, although there are very many other styles, which vary according to the individual taste of the wearers.

Horsback riding of late years has become a very fashionable pastime, and our avenues and Central Park are crowded with equestrians early in the mornings and late of evenings.

Ladies especially within the past few years are much given to this healthy exercise, and our riding schools are filled with pupils learning the art of horseback riding.



The skirt of this habit is much shorter than those of former years, and is made with very little drapery. It is mostly worn with trousers made from the same material as the habit, or from black doeskin.

Riding habits are mostly made from light-weight cloths—brown, dark green, blue, and similar colors predominating in favor.

Fifteen years past cutting a riding skirt was very easy, there was no system to it, only plain, straight pieces of cloth cut about 6 inches longer than sole of foot. The top was gathered to fit the waist, that finished it. But at the present time we can be proud of saying that riding skirt cutting is done to fine point, systematically, as the body of a garment. Away with all fullness! What does not require fitting smooth on the lady's lap, and when mounted no wrinkles above or below the knees. Elastic should be used for right and left lap to keep the skirt in firm when riding.

On the opposite page we represent a diagram of a most serviceable riding skirt, excellent in its style and fit, and one of the leading in Paris, London and New York.

Measurements for skirt to be used same as for trousers, with the extras of front and back from waist to sole of foot.

FULL MEASUREMENTS.

Waist,	- - - - -	24 inches.
Seat,	- - - - -	42 "
Rise,	- - - - -	12 "
Lap,	- - - - -	22 "
Side Length,	- - - - -	42 "
Front Length,	- - - - -	42 "
Back,	- - - - -	45 "

DRAFTING THE SKIRT.

1. Draw a line.
2. Square line 2 by 1.
3. Rise measure, 12 inches. Apply 12 inches from line 2 to 3.

(CONTINUED ON PAGE 32).

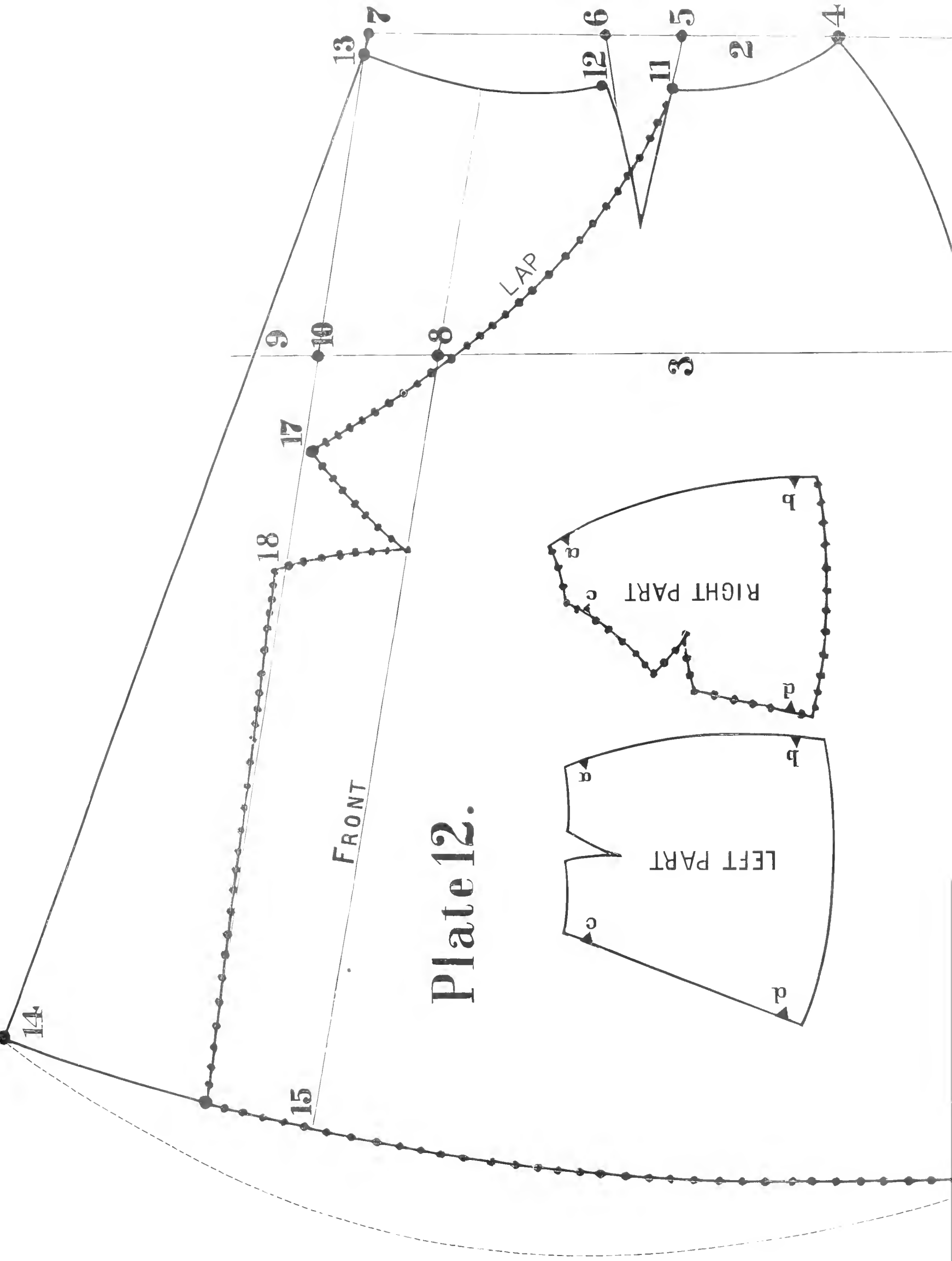

Plate 12.

(CONCLUDED FROM PAGE 30).

4. Waist measure, 24 inches. Apply the fourth part (6 inches) from line 1 to 4, on line 2.

5. From 4 to 5; again the fourth part of waist.

6. From 5 to 6, the eighth part of waist. Make a **V** from points 5 and 6.

7. From 5 to 7, the half of waist.

8. Seat measure, 43 inches. Apply half from line 1 to 8 on line 3.

9. From 8 to 9, the third part as there is from line 1 to point 8. Now draw a line down from point 7 and point 9.

10. From 9 to 10, the third part as there is from 9 to 8. Now draw a line down from point 7 and point 10.

11. 2 inches below point 5.

12. 2 inches below point 6.

13. 1 inch below point 7.

14. Side length, 42 inches from point 7.

15. Front length, 42 inches from top and centre between points 12 and 13.

16. Back length, 45 inches from point 4 to 16.

17. Lap measure, 22 inches from point 11.

18. About 6 inches, for **V** on knee, from 17 make **V** 6 inches deep. (Don't cut the same out before skirt is tried on.) Cut the left part about 6 inches longer on side in order to cover the left foot when mounted (see darts on bottom of diagram).

In cutting the cloth for riding skirt be careful to place your pattern on cloth with right and left part; make an allowance of  $3\frac{1}{2}$  inches on bottom for a hem. Opening for skirt to be made straight with the **V**.

### Plate 13.

#### CUTTING A NEWMARKET

FROM A JACKET OR OTHER SHORT GARMENT.

Fig. 1.

DRAFTING THE BACK.

**A.** Draw a line a little over the length measure of newmarket.

**B.** Place top of back on line A, and 1 inch upward in waist.

**C.** The full length of newmarket, and allow 1 inch for making up from top of back.

**D.** Width of Back on bottom,  $1\frac{1}{2}$  inches less than the sixth part of bust measure, say  $4\frac{1}{2}$  inches, if 36 inches bust, from C to D.

Now draw back, as shown on diagram.

Fig. 2.

DRAFTING THE SIDE-BODY.

Draw a line.

**E.** Place side-body  $\frac{3}{4}$  of an inch upward in waist, and with the blade on line.

**F.** From E to F same as there is from B to C (see Fig. 1).

**G.** Width of side-body the fourth part of bust measure, and allow  $1\frac{1}{2}$  inches to it,  $10\frac{1}{2}$  inches, if 36 inches bust.

Now draw side-body, as shown on diagram.

Fig. 3.

DRAFTING THE FOREPART.

Draw a line and place your forepart on the line, as shown on diagram.

**H.** Place front-side 1 inch back from forepart.

**I.** Side from forepart  $1\frac{1}{4}$  inches at the waist.

**J.** Make allowance outside of side-body same as the lap of side-body over forepart.

**K.** Length of front. This may be measured on customer and applied on draft, or make your front  $2\frac{1}{2}$  to  $3\frac{1}{2}$  inches shorter than the back length.

**L.** Width of forepart half of seat measure, say 23 inches, if 46 inches seat. Length of side to correspond with back side body.

**M.** Depth of front dart 7 inches below waist.

**O.** Depth of side dart  $3\frac{1}{2}$  inches below waist. Make allowance on front for lap.

Fig. 4.

This diagram represents how a shoulder yoke is cut for any style, either cape or circular. Place forepart and back of any garment together with the shoulder seams, then draft your yoke, as shown on diagram.

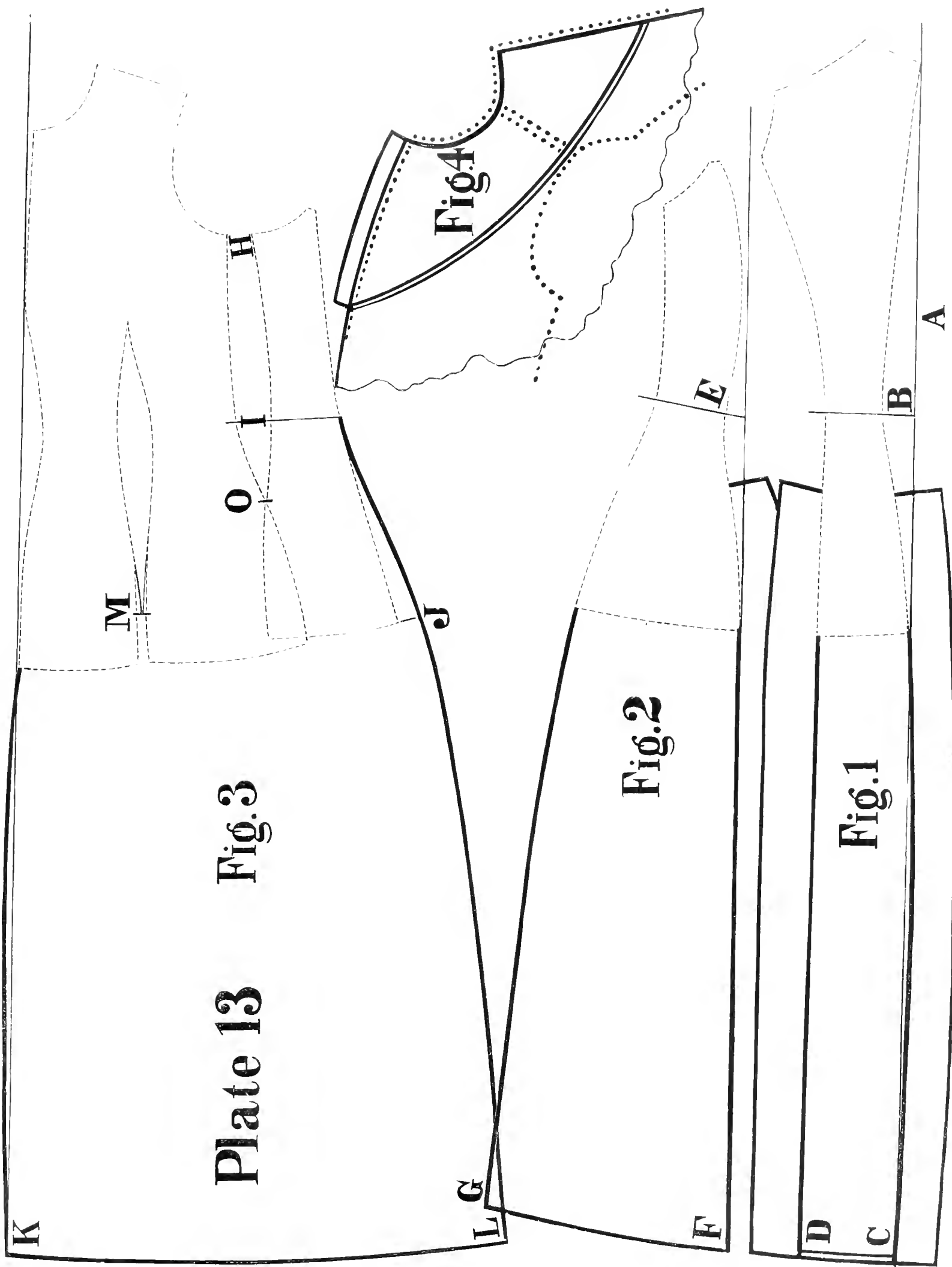

Plate 13 Fig. 3

Fig. 2

Fig. 1

FIG. 4

K

L G

F

D

C

A

B

E

M

O

H

I

J

**Plate 14.**CUTTING A WRAP FROM A PLAIN  
JACKET, ETC.

This system of cutting a wrap, given below, is a supplement to one already given on page 20 and plate 7. But to make this book more valuable we present you the below instructions of cutting a wrap sleeve from a plain coat sleeve which will save you time in cutting and fitting the wrap for a customer. You have a jacket or a waist fitted already.

Fig. 1.

## DRAFTING THE SLEEVE.

**A.** Place back and sleeve together as shown on diagram.

**B.** To be placed level with point A.

**C.** Draw a line up from point B, elbow of sleeve.

**E.** Measure from C to D, and apply the same from C to E, on line C.

**F.** Notch for sleeve  $\frac{3}{4}$  of an inch below coat sleeve notch. Now draw your wrap sleeve as shown on diagram.

## THE BACK.

Cut your back about  $\frac{1}{2}$  of an inch narrower on the shoulder as the regular coat back, and about 1 inch wider to back on the waist.

Fig. 2.

## THE FOREPART.

In altering the forepart take off  $\frac{1}{2}$  of an inch on the width of shoulder, and the armhole 2 inches lower from the regular.

Fig 3.

## THE SIDEBODY.

For wrap cut to correspond with forepart. Under sleeve and C, see Page 20.

## ITS SWIFTESS OF EXECUTION OF THE ABOVE SYSTEM.

In these days of hurry, when *time* is reckoned so valuable that minutes as well as hours are considered, we all aim to economize time as much as possible; "time is money," therefore it is desirable in selecting a system to get one that produces good results and consumes the least time in drafting the garment, for in so doing we are selecting THE BEST-PAYING system.

This system is not only simple in its construction, reliable in its results, but occupies less time to cut a correct wrap than any other offered. Hence it is pre-eminently to your advantage to learn it, for "economy is wealth."

## "DECOY DUCKS."

"Decoy Ducks" are very properly described by an observing friend as "the prominent persons whose names appear as patrons, trustees, etc.," of the various weak institutions that are *begging* for public consideration.

Very frequently this trick and device is resorted to by unscrupulous persons to foist upon the uninitiated and unsuspecting public, *bogus institutions*, and not unfrequently the names of prominent individuals are used without their knowledge or consent. As an illustration of this fact we refer you to the case of *the bogus Medical Institute of Philadelphia*, which was publicly exposed after existing for years upon the moral support given it by the illegal use of the names of popular men throughout the country. But in time all this rascality is exposed and the institutions resorting to such mean expedients are landed upon the rocks of adversity *hopeless wrecks*.

(CONTINUED ON PAGE 36.)



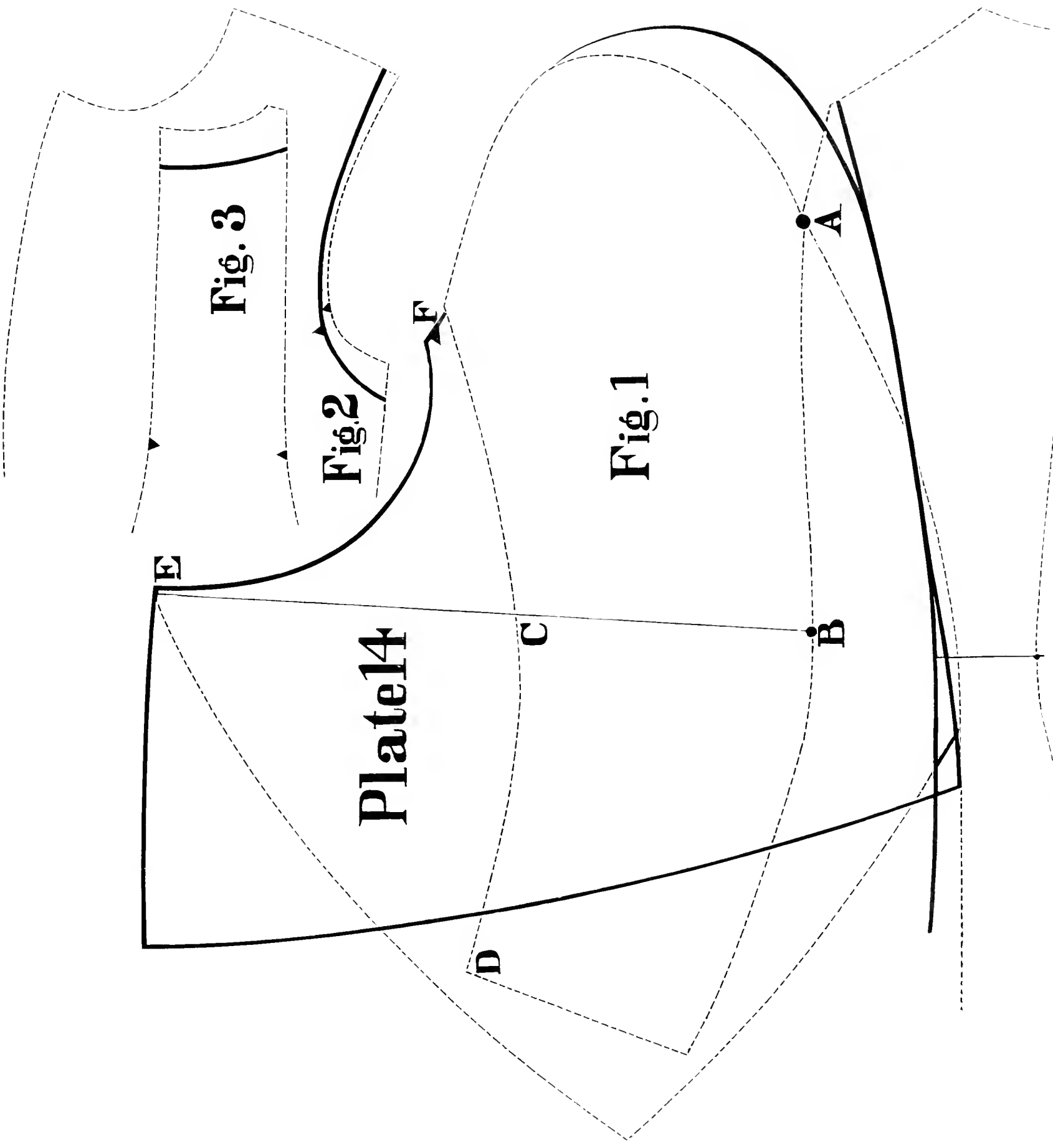

## Plate 15.

OUR FAVORABLE DESIGN FOR SEAL  
PLUSH, ETC.

This style of cutting wraps, as shown on diagram, is very favorable mostly in cases of seal or seal plush. It is our standard design, and very valuable as it saves much of material on account of lower side and sleeve being cut in one piece. Short side bodies (see darts - - - - -) cut about  $3\frac{1}{2}$  inches below waist to be put under the arm in order to hold the forepart in shape. This can be cut of silk or farmersatin or any other suitable material. An elastic band can be placed under the arm and waist to answer the same purpose.

## THE DRAFTING.

Draft your back and forepart same as given on page 20, and Plate 7.

**A.** To form the sleeve about 5 inches below waist.

**B.** The fourth part of bust and allow  $1\frac{1}{2}$  inches from point A to B for width of side. Now draw a straight line down, this will give you width of side on bottom.

**C.** From B to C,  $3\frac{1}{2}$  inches, apply your seat measure on back side and forepart, if not enough as measure calls for, make allowance from B to C, if more than measure calls for, break off from point C. Now draw your forepart and break off bottom  $3\frac{1}{2}$  inches from back to forepart on account of side being wider.

**D.** From  $1\frac{1}{2}$  to 2 inches for turn up from B. Make front of upper sleeve about 12 inches wide.

**E.** From C. to E same as there is from B to D. Make the under sleeve same length as upper and 4 inches narrower in front than the upper.

Short wraps can be cut in the same way; sleeve and lower side in one piece and upper side bodies to be put in from lining in order to save valuable material. (See dots on Diagram - - - - -.)

(CONCLUDED FROM PAGE 34.)

## "DECOY DUCKS."

Some of these "decoy ducks" are of solid wood, even to the head, while others extremely hollow are of *brass*, but one kind is just as mischievous as the other, and both need watching at this time, especially, for the prosperous season has brought out a great many hunters after snug surpluses that numerous people have begun to accumulate. "A wink is as good as a nod to a blind horse." To make the application of the above remarks more plain and clear to *the hasty reader* we would impress upon his mind that not all the names printed and used by certain persons are used with the consent of the individuals, but they are illegally used and purposely published as *decoys* to deceive the unwary public. Their object is like that of the spider to the fly—they aim to get you in their clutches, and for this purpose flamingly publish the names of prominent individuals as trustees, etc., and use these names as "decoy ducks."

We would advise you to give them "a wide berth," for so sure as you allow them to fasten their fangs upon you, you are a victim to their unscrupulous thirst for money, and they will fleece you without mercy. Listen not to their siren songs, but if you should be lulled by their cadence for a moment, shake off your lethargy and remember the warnings we have given you.

All interested persons who desire to know "the bone and sinew" of the Tailors' and Cutters' Exchange can have full particulars upon application at our office. But we publish no names—WE USE NO "DECOY DUCKS."

# Plate 15

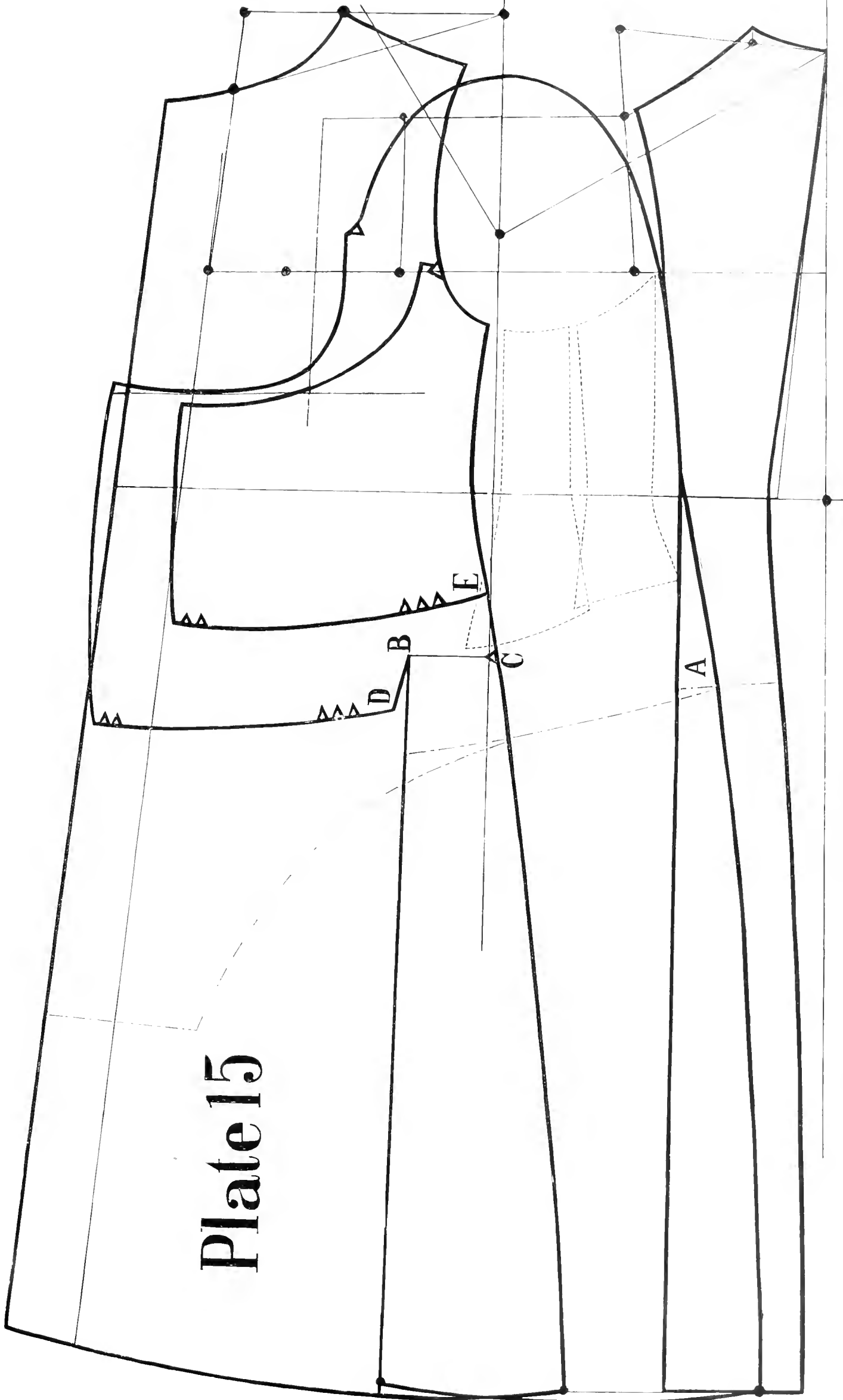

**Plate 16.****THE JERSEY WAIST.**

## IMPORTANCE FOR CUTTING JERSEY MATERIAL.

Allowance must be made at the length of waist from  $\frac{1}{2}$  to 1 inch according to stretching of the material; the same allowance must be made on front balance. Allow from  $\frac{1}{8}$  to  $\frac{1}{4}$  to nape measure. Reductions must be made in bust, waist and hip.

## DRAFTING A JERSEY WAIST.

**A.** Length of shoulder, say  $3\frac{1}{2}$  inches for a 36 inch bust.

**B to C.** Take out 1 inch.

**D to E.** Take out 1 inch. This is done to make allowance for the stretching.

**F.** Take out from armhole in front  $2\frac{1}{4}$  inches. Waist to be cut in the same way as bust, 2 inches less than the measure. Armhole to be cut not lower than bust line. All other points to be done the same as other garment.

**H.** If forepart is wanted without a dart take 1 inch from straight line.

**G.**  $\frac{1}{2}$  inch less than the fourth part of waist measure from H to G.

## DRAFTING A ONE SEAM SLEEVE FOR JERSEY.

1. Draw a line.
2. Square by line 1.
3. The fourth part of bust measure from line 1 to 3.
- 4 and 5. Same as other sleeve,
6. From line 3 to 6 the fourth part as there is from line 1 to 3.
7. From line 1 to 7 the same as there is from line 3 to 6.
- X. Length of sleeve same as other.
8.  $1\frac{1}{2}$  inches from point X to 8.

9. Width of bottom, 1 inch less than the fourth part of bust measure. Now draw your sleeve from point 6 to 8 with about  $\frac{1}{4}$  of an inch allowance, and 7 to 9 about 1 inch curve.

Sleeve for jersey waist can also be cut plain with two seams.

## OUR SYSTEM OF SHIRT CUTTING.

Each year has produced improved systems for cutting shirts, and every year there is a growing demand for shirt-cutters of talent, to whom large salaries are paid; in fact, the shirt-cutter's pay rivals that of the tailor's, and as this demand increases for expert shirt-cutters, it is well for young men to give it their attention.

One of the simplest, most perfect, and reliable shirt systems we have is one recently invented by Messrs. Dittmar & Sheifer, of the Tailors' and Cutters' Exchange, which possesses real merit. A gentleman, recognized as one of the best shirt-cutters in this country, after witnessing the swiftness with which it performed its duty, acknowledged that it surpassed anything in its line he had ever examined, and, to test its correctness, drafted a pattern by his method, which took exactly twice as much time as that occupied by us in drafting one by our system, and, upon laying these patterns upon each other, it was found, to the surprise of all present, that they corresponded in every part; in fact, so near alike were they that any person would have believed that one pattern was copied from the other.

This business of shirt-cutting is assuming vast proportions, and any one not familiar with the subject, and who has given the subject no thought, would be surprised to realize the extent of talent, capital, etc., invested.

We are prepared to teach our system of shirt-cutting to any person desirous of learning, or we will sell drafts of it for self-instruction.

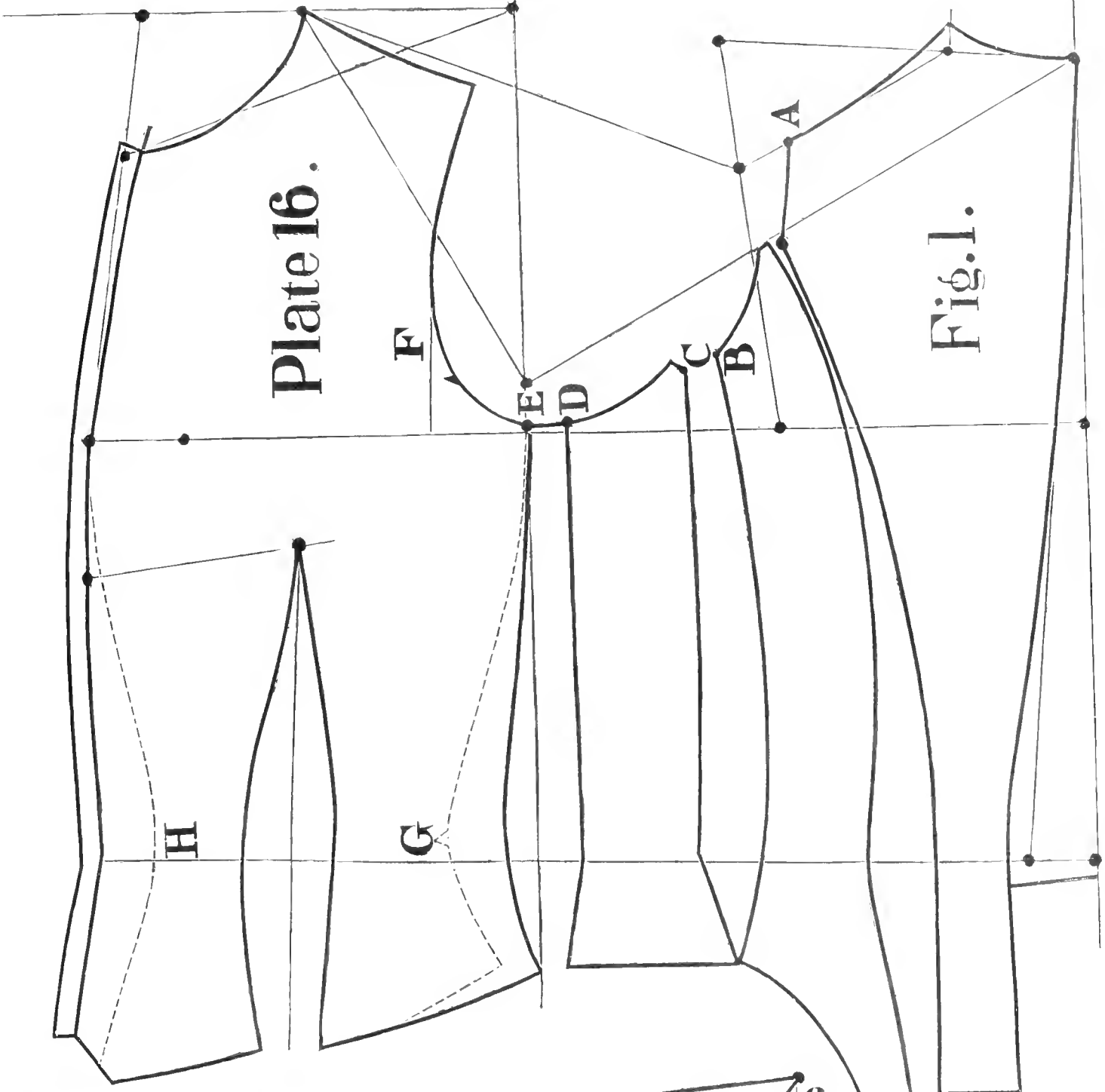

**Plate 17.**

## THE FULL VEST WITH BACK.

Fig. 1.

**18 to 19.** Allow  $1\frac{1}{2}$  inches for seams.

**A.** Forepart  $1\frac{1}{2}$  inches from central line. Draw your forepart from this point and curve it in to the waist, touching on the central line. Now take out  $\frac{3}{4}$  of an inch between forepart and back, on bust line, and 2 inches on waist line.

Forepart and back darts to be taken out according to waist measure, by measuring the forepart from point to central line. Deduct the fourth part of waist measure and take out the balance on dart, making allowance for seams; back is done the same way.

Length of forepart in front is cut from 5 to 7 inches below waist according to taste and style; side length, 2 inches below waist.

## THE PLAITED GARMENTS.

Fig. 2.

BOX AND PLAIN PLAITS, OR ANY OTHER PLAITS.

By this illustration you will see and admit the simplicity of cutting plaited garments. As a matter of fact, when a plaited garment is made up you wonder how complicated it must be to cut such a garment; how much you should allow for this and that, box or plain plaits. But after you have the idea we give you will think different.

In cutting a plaited garment take a piece of paper, make your plait on the paper to suit yourself, any style you prefer, then place your pattern on the paper with the folded plait, as shown on diagram; cut the same out with the fold. Now spread your pattern apart (see fig. 4), this way you cut the cloth, not forgetting notches for plaits.

Fig 3 and 4 represents a forepart with plain plaits. Fig. 3 when plaits is formed and pattern marked on it. Fig. 4 when the same is spread open.

## THE COMBINATION OF STYLE AND COLORS.

This is a subject of vital importance which is too often neglected by the cutters—that is, to make a study of the effect of the combination of colors and their bearing upon the styles of garments most becoming to the various customers.

A lady who is short and thick requires a different character of garment from one who is tall and slender. While one color, or certain combinations of colors, will have a pleasing effect upon one, the same upon the other will have a contrary effect.

A short and stout woman will go to her tailor wanting a certain style of goods made into a certain style of garment. She wants it because she saw a suit similar in every respect upon her well-shaped and tall friend, which was very becoming to her. The goods are purchased and the garments made, but the short customer is dissatisfied, and insists that the suit does not fit, and she is not at all pleased with its appearance. The cutter examines the suit, and is surprised at this adverse criticism—it *does* fit in every respect, and, as the points of its perfection are pointed out to the customer one by one, and she is shown that the suit is faultless, she reluctantly admits the force of the argument, but insists that it *looks* entirely different upon *her* from her well-proportioned friend, and wonders why the difference is so apparent and the garments so ill-becoming to her. Not once has the vast difference in the

(CONTINUED ON PAGE 42.)

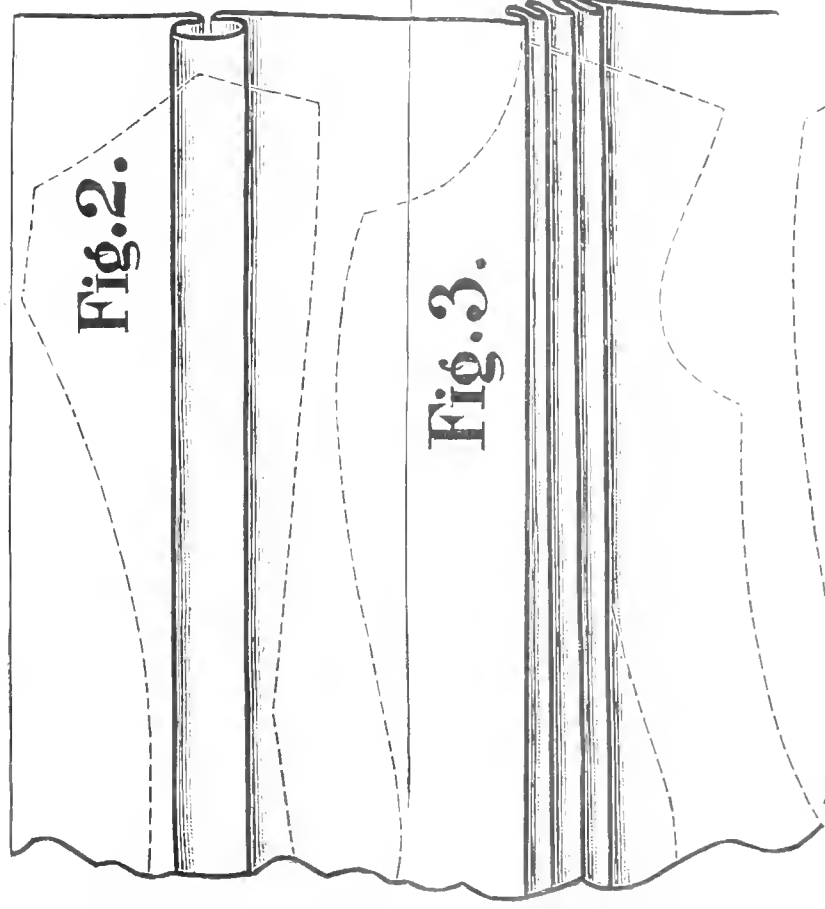

Plate 17.

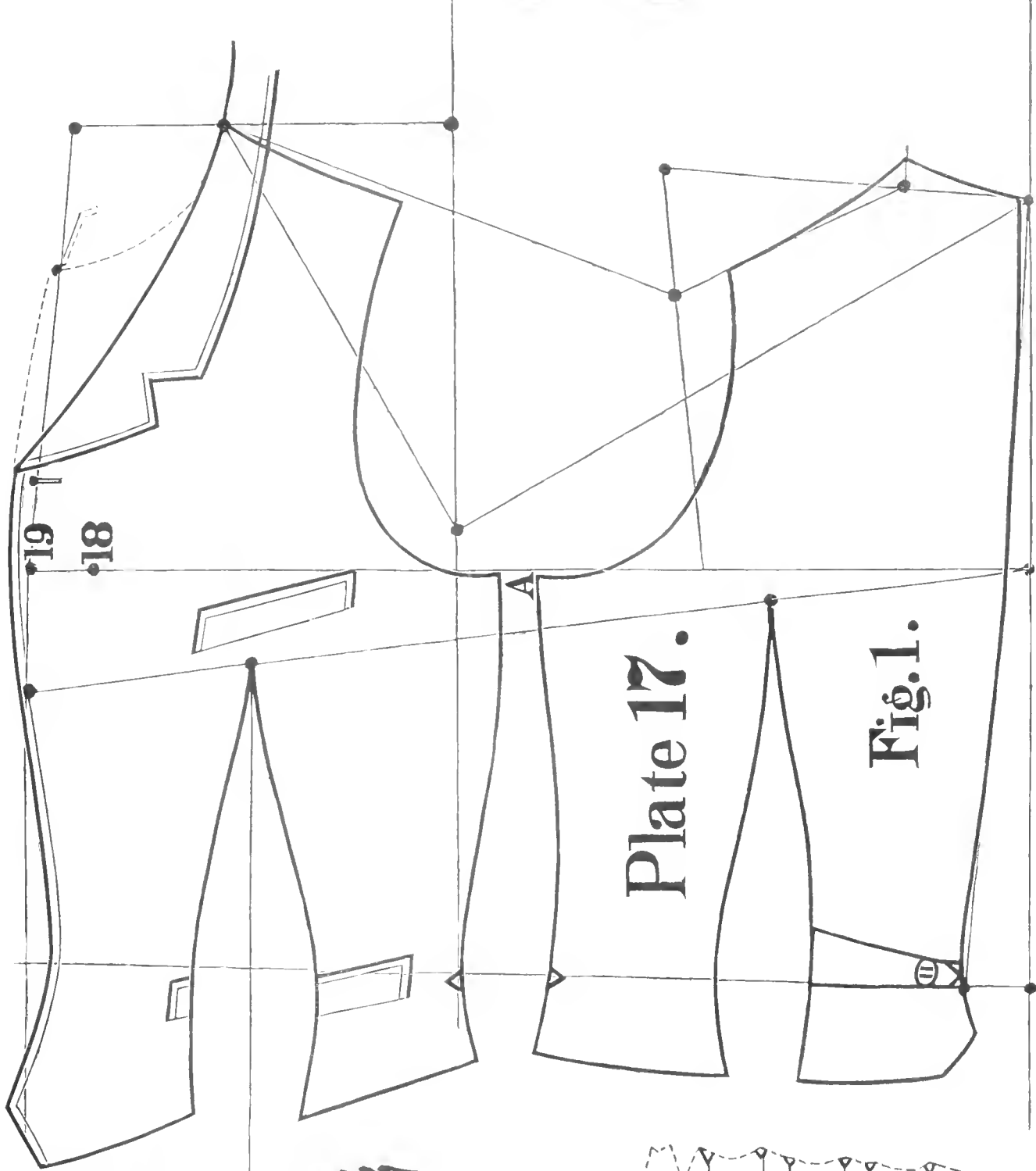

Fig. 1.

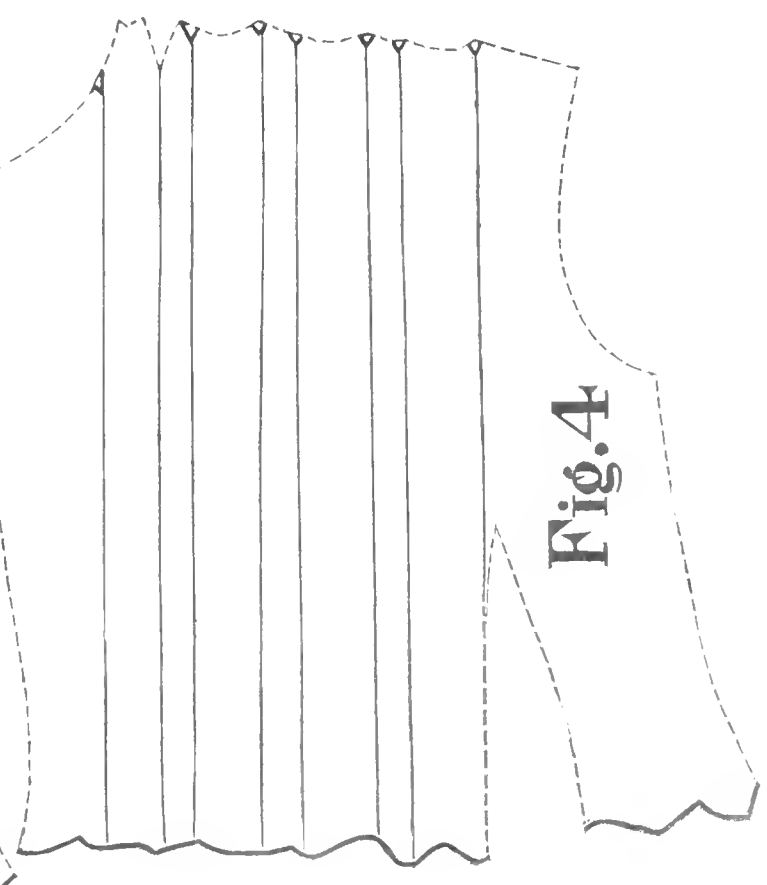

Fig. 4.

## Plate 18.

THE POLERINA CAPE.—CUTTING A  
RUSSIAN CIRCULAR.

Fig. 1.

This diagram represents the old fashion polerina cape. This garment which has been worn by our grand mothers and great grand mothers has been forgotten for a good many years past. But this season of 1891 it comes back to us like a long lost child; it is favorable in every respect and admired by all classes of people as a comfortable and fashionable garment as a street costume for spring and summer; very easy to cut (if you know how), easy to make and noble in its appearance.

All measurement required for the above is neck and length. Say 15 inches neck measure, take a 36 size pattern and place on your back and forepart together with the shoulder seam, as shown on diagram, this is all it needs. Now mark your cape, as shown on diagram, straight with back and forepart.

Fig. 2.

## THE RUSSIAN CIRCULAR.

The top part of the circular is cut the same as the plain shoulder cape, given on Plate 8, page 22. Length of back according to measure on the straight line. Bottom of circular to be cut the full bust measure and allow the sixth part of the bust to it (for half of circular). Front is cut either by measure or 3 inches shorter than back.

(CONCLUDED FROM PAGE 40.)

THE COMBINATION OF STYLES AND  
COLORS.

shape and style of the customer impressed itself upon *his mind*. A little thought upon her part, or a few well-considered suggestions from the cutter upon this subject, would have convinced her of her error in ordering such shades of goods or styles of garments. But the customer alone is not to blame in the majority of cases, for the cutter, who stood silently by and acquiesced in his selection, should be charged with blame for making up the garments without offering a protest. Sorry am I to say it, but it is true that not every cutter is sufficiently educated on this important subject to offer advice, and, through this culpable ignorance, neglects an important duty to the customer. A doctor who is ignorant in any important part of his profession would be denominated "incompetent." A lawyer who had neglected to inform himself thoroughly upon the ethics of his profession would be called "non-compos," and a cutter who so neglects this important part of his education will never attain eminence. He should so thoroughly study this subject that the moment he inspects a customer he should be able to decide without hesitation and correctly not only the style of garment most becoming, but the style of goods and shade of color most desirable and suitable for his shape, size, style, and complexion. All these points are necessary to be comprehended and duly studied, and the cutter who studies them most comprehensively and acquires a due appreciation of their bearing will prove the most successful, and, finally, attain eminence, distinction, and wealth.



CREASE

Fig. 2.

Fig. 1.

Plate 18.

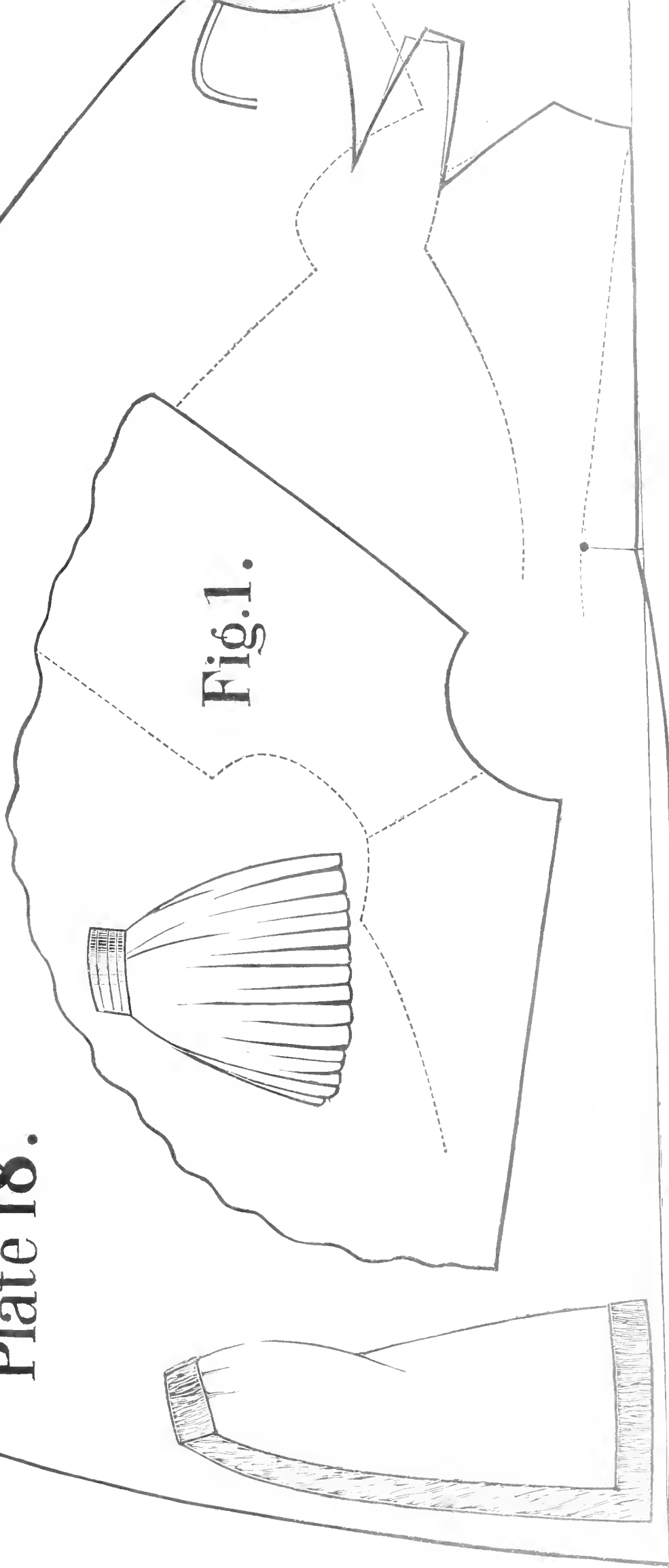

Plate 19.

CUTTING A PLAIN SKIRT

FOR STREET OR DRESS COSTUME.

Measurements required for cutting a lady's skirt are as follows :

Waist, say	-	-	-	-	24.
Seat, "	-	-	-	-	45.
Front length, say	-	-	-	-	42.
Back length, say	-	-	-	-	45.

DRAFTING,

1 and 2. Square line.

A. The full waist measure from line 1 to A.

B. The fourth part of waist measure from line 2 to B.

C. Front length measure 42 inches. Apply 42 inches from point B. to C.

D. The fourth part of seat measure from C to D. Square line up from point D and line 1.

E. The fourth part of waist measure from point B to E.

F. In the centre between E and A.

G. In the centre between E and F.

H. Seat measure 45 inches. Apply 45 inches from point D to H.

I. One inch less than the half of waist measure from point D to I.

J. From H to J the same as from D to I.

K. In the centre between I and J. Now draw lines from points E, I, G, K, and F and J.

L. 1 inch above point A.

M. Back length, 45 inches. Apply 45 inches from point L to M. Now curve the bottom of skirt from point C to M, as shown on diagram.

CUTTING THE MATERIAL.

In cutting the material for skirt allow about  $1\frac{1}{2}$  inches on top of waist; cut the front piece in crease and make a V on top of waist in order to fit the stomach properly. Back piece is cut single. Side pieces may be cut one opposite the other in order to cut the material to the best advantage. *This can only be done if the material does not shade and there is no nap to the same.*

Narrow skirt can also be cut with one side piece. By doing so points A and H should be applied  $\frac{1}{2}$  of the measure less, and points G and K is let out.

INSTRUCTION DEPARTMENT

OF THE

Academy for the Art of Cutting

OF THE

TAILORS' AND CUTTERS' EXCHANGE.

758 BROADWAY.

DITTMAR & SHEIFER, DIRECTORS.

TERMS FOR INSTRUCTION.

Terms for a complete course of Instruction in Ladies' Garments, including grading, to Practical Tailors, Furriers, or Dressmakers,	\$100.00
" to others,	150.00
" for Grading all Ladies' Outside Garments,	50.00
" for a complete course of Instruction in Gentlemen's Garments,	100.00
" Practical Tailors,	50.00
" for Grading,	50.00
" to Cutters desiring to change their System,	50.00
" to Cutters for Coat System alone,	30.00
" to Cutters for Pants System alone,	20.00
" to Cutters for Vest System alone,	15.00
" for Instruction in measuring, drafting, or explaining points occupying from one hour to one day	\$5.00 to 20.00

LADIES' UNDERGARMENTS.

Terms for Cutters,	\$25.00
" for others,	50.00

GENTS' SHIRTS, UNDERGARMENTS AND OVERALLS.

Terms for Cutters,	\$50.00
" for others,	75.00
" for Grading,	50.00
" for Gentlemen's Dress Shirts only,	25.00

Tuition must be paid in advance in all cases.

# Plate 19.

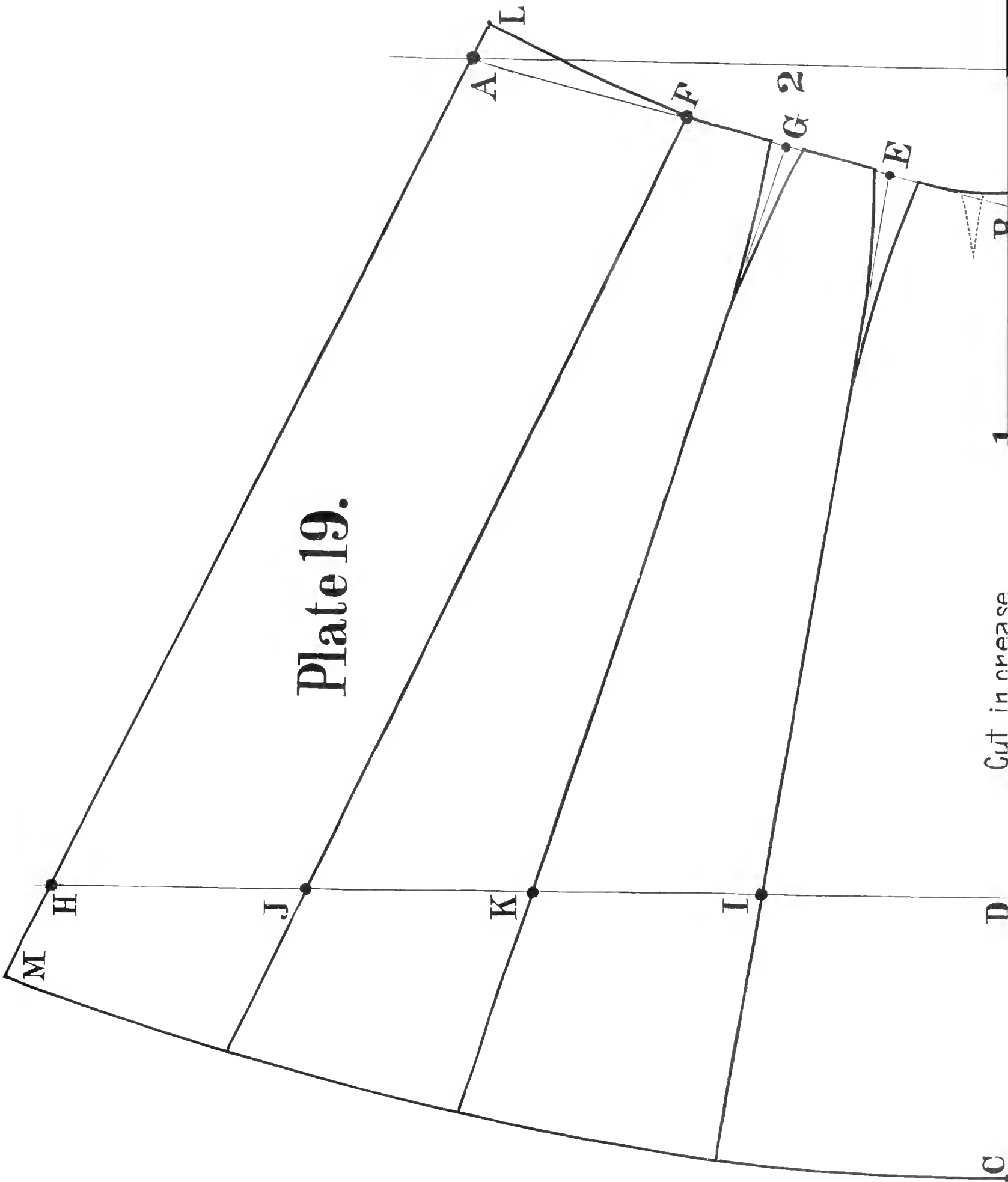

Cut in crease

D

C

**Plate 20.**

## THE DRESS WAIST.

WITHOUT SEAMS, SUITABLE FOR SILK, CLOTH OR ANY OTHER MATERIAL.

The cutting of a dress waist, which is presented on opposite diagram, is far superior to all others; its shapes and curves for the human form cannot be equaled. As a rule by all dress-makers and ladies' tailors, this pattern is cut without seams, and by cutting the material, seams including, outlets are allowed. To do this, lining is perforated with a tracing wheel right on the lines of your draft than allowance is made.

## THE DRAFTING.

18, the half of bust measure, no allowance above.

**A.** 1 inch below point 17, for neck shoulder point.

**B.** Forepart to be placed  $1\frac{1}{2}$  inches below line 3. If 3 side-bodies preferred take 1 inch below line 3, draw a line down for forepart.

**C.** From the front of forepart to C, the third part as there is from line 3 to front of forepart.

**D.** From C to D, 1 inch less as there is from front to C.

**E.** Allow 1 inch from straight line. Now draw a line from point 18 down by point E. Shape your front as shown on diagram.

Front darts to be taken out by measuring from point E to B. Deduct the fourth part of waist (6 inches) and take out balance of measure of front darts.

**F.** From line 3,  $\frac{1}{2}$  of an inch for armhole.

Cut the back for dress waist  $\frac{1}{2}$  of an inch below point 13, and from  $\frac{3}{4}$  to 1 inch wide on waist line; take out  $1\frac{3}{4}$  inches from back to side. Side-bodies, if two or three to be divided equally, shoulder should be cut very narrow for waist, say  $3\frac{1}{2}$  inches.

## THE SLEEVE.

Fig. 2.

Draft your points same as given on Plate 4. Hollow the elbow 2 inches in front and about  $1\frac{1}{4}$  inches in back for upper-sleeve. Draw your under-sleeve in the centre of upper on elbow. Bottom of sleeve to be cut 1 inch less than the fourth part of bust measure. Notches should be placed on both upper and under, about 3 inches above and below elbow in order to bring the fullness of the elbow in its right position.

Baggy, plaited, fancy or any other sleeve can be very easily put on the top of the plain lining, as the lining of sleeve must have its regular form to fit on the arm.

## A FEW WORDS TO THE GRADUATE.

The principles of all ladies' garments are represented in this book. To produce other designs, such as plaiting on ornamental garment, can easily be brought out (after reading and thoroughly understanding this book) by using your own judgment—*of course, taste and ability is necessary.*

Should you misunderstand any of the instructions, we shall take the pleasure of forwarding further explanations on application within six months after book is purchased.

Yours Respectfully,

DITTMAR & SIEFFER.

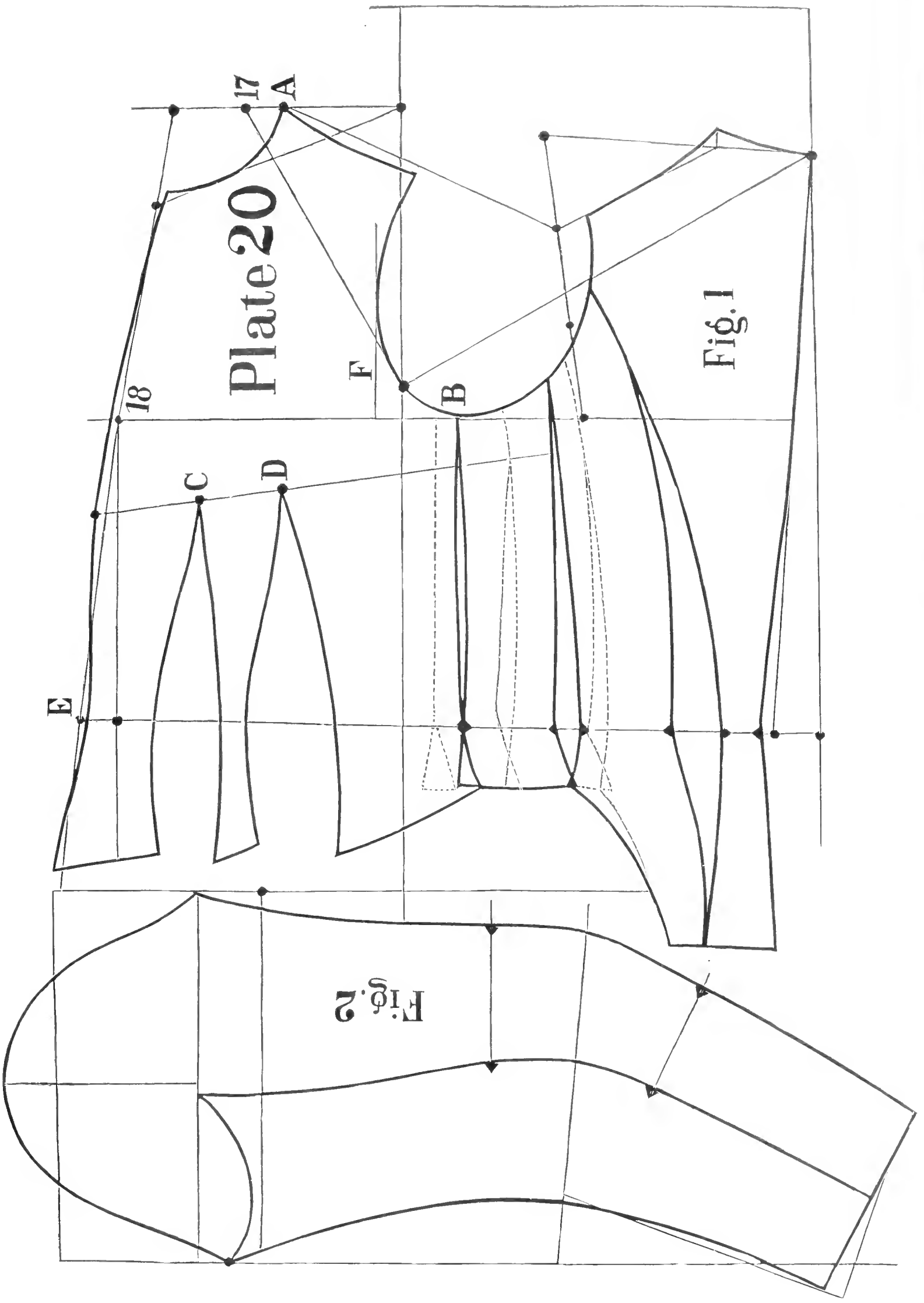

Plate 20

Fig. 1

Fig. 2

E

C

D

F

B

A

18

17

# INDEX

	PAGE.		PAGE.
Custom and Wholesale Department, (illustrated).....	3	Cutting the Shoulder Capes.....	22
Preface.....	4	Drafting a High Shoulder Cape.....	22
Its Simplicity.....	4	Drafting a Circular.....	24
Its Reliability.....	4	The Vest.....	24
Its Swiftness of Execution.....	4	Cutting the Skirt Garment.....	26
Our System of Cutting.....	5	Ladies' Riding Trousers, the Measurements and Drafting.....	28
Tailors and Cutters Exchange.....	6	Drafting the Trousers.....	28
The Power of Memory.....	6	Drafting the Back Part.....	28
The Dignity of Tailoring.....	7	Ladies' Riding Habits.....	30
A Word to Cutters and Tailors.....	7	Full Measurements.....	30
The Measurements.....	8	Drafting the Skirt.....	30-32
Drafting the Outlines.....	10	Cutting a Newmarket from a Jacket or Other Short Garments.....	32
Drafting a Garment.....	12	Drafting Side Body.....	32
Cutting out the Pattern.....	12	Drafting the Forepart.....	32
Importance after Cutting out.....	12	Decoy Ducks.....	34
Drafting a Sleeve.....	14	Cutting a Wrap from a Plain Jacket.....	34-36
Drafting the Collars.....	14	Our favorable design for Seal Plush, etc.....	36
Special Notice.....	14	The Jersey Waist.....	38
Drafting a Loose Front Garment.....	16	The Full Vest with back.....	40
The Vest.....	16	The Plaited Garments.....	40
The Beauty of a Garment.....	16	The Combination of Style and Colors.....	40-42
The Pecuniary Value of Taste.....	16	The Polerina Cape—Cutting a Russian Circular.....	42
Drafting a Plush Garment.....	18	Cutting a Plain Skirt.....	44
Drafting Bottom of a Sack or Newmarket.....	18	Instruction Department of the Academy for the Art of Cutting.....	44
Special to Furriers.....	18	The Dress Waist.....	46
Our Success with Furriers.....	18	A Few Words to the Graduate.....	46
Drafting a Wrap.....	20		
Drafting.....	20		
The Japanese Sleeve.....	20		















LIBRARY OF CONGRESS



0 014 061 921 8