



**Rules, Systems
and Methods**

Coats and Vests

DOOLITTLE



Class _____

Book _____

Copyright N^o _____

COPYRIGHT DEPOSIT.

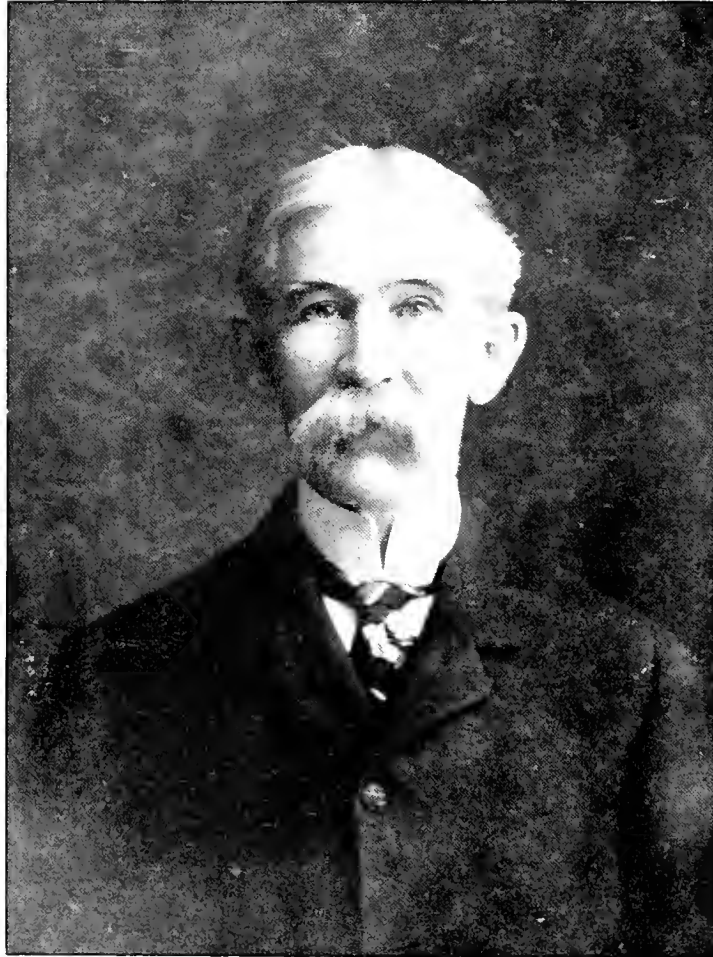

Oliver T. Doolittle

STRAIGHT SHOULDER RULES, SYSTEMS AND METHODS

OF THE

PRESENT DAY

BY

OLIVER T. DOOLITTLE

COATS AND VESTS



PHILADELPHIA
OLIVER T. DOOLITTLE, PUBLISHER

1901

EX. 100
P. 14 1901
CLASS. XXa N
34
COPY 2

COPYRIGHT, 1901, BY OLIVER T. DOOLITTLE

PRESS OF SHERMAN & CO.
PHILADELPHIA

PREFACE.

IN the introduction of an entirely new rule and system of Men's, Women's and Boys' garment cutting you will find them in this present age, in all their workings, as having for their base an established principle for foundation; and these are the results of over forty years of practical experience in the tailoring business. (In making the distinction in appliance of rule and system it is better to explain and designate them separately in giving points as to their different merits.)

Since retiring from the tailoring business I have evolved this system whereby it can be comprehensively, easily and practically imparted, as all problems in their different forms of working reach one and the same result as proof, differing from the old rules and systems of the past, and do not require the time and experience to find out from them the changes necessary to be made, as in the old.

There is nothing egotistical in the above mention of the old, as it is an open secret with all experienced cutters that they can produce but poor results working out problems from only the knowledge first taught them. It is from years of actual experience of the many old, and from their unpractical workings, that this book is evolved. It embodies all that is essential to guide one right from the start. First we have the proportionate rule foundation and that based on principle, with proof of the points and location as going together in harmony with each other; the established center, to prove from as a rule without proofs, is not to be relied upon, and one that proves as to points located must necessarily prove itself right. A good rule must be based on principle, and by it proportion to work from. The better the proportion (and all are not of the same) as to their points and location, the better the rule to apply measures as taken to govern. Different rules and systems have different points of location, and when measures are applied as taken to a draft in drafting, points are placed in a position to apply measures that do not go as placed nor as taken, in most rules, to quite a space; and, in consequence of it all, points are out of proper location and not in harmony as they go together.

The measurement rule to draft by measure, having the proportion as a guide, it will be found often of great assistance to help decisions, especially for the long-neck form; that no rule governs the location as well as the use of proportion to locate the front shoulder-point in harmony with the back, as to the extra depth taken for back scye depth, while the measure taken for the stooping form may call for as long, the front strap measure would locate for it, while not in the long, erect neck form. If a measure could be so taken on any part of shoulder of the form by the holding of tape to it and feeling for the location to locate by and then to apply it on a flat surface, as that of taking over the round in the same twistings and turns, there may be in it more than guess-work, surely no certainty of good result and one of the many that are not practical in the old.

In the introduction of this work the author will, in preface and other writings, give in it his personal views and experiences. Many may think it unnecessary for lengthy explanations and remarks, and that to abbreviate would be greatly appreciated. As this work differs with most all in the working, it will not assume that while some do the major percentage in this line of pursuits, they do not know it all, and by those it may be appreciated, while the practical ones of experience, and many who are not, may think differently. It will not harm any, and will, no

doubt, prove most valuable to many, as this work is being published to be the privilege of all, and he leaves it, of course, to the option of all, as to the acceptance of this privilege. In any event, it will serve the intent of the author by saving time hereafter for frequent calls for it by now giving it to them, leaving to any their own criticisms on it, and holding no one responsible for any mentions in the work, and gives all rules and systems as entirely original and individual.

The pattern system of changing from one form to that of another, either of one's own pattern or of others—this system is included in this book, as well as in all of the other different branches of this work. It is very valuable and of great assistance, as in the illustrations of changes for the different forms and production of different garments it enables one to be self-reliant; it instructs in all its branches, enabling you to better produce without the trying-on, which has harmed tailoring more than anything. You can work with more confidence—in fact, it is the most artistic and scientific part of tailoring, and only what you do in trying-on a garment from the other ways of producing the same results. It is of assistance as well when drafting by measure to know the changes and their effects, as this system will illustrate to one if it is better to illustrate by it, then it is surely better to apply; and giving as it does the scientific and practical part of producing, as by the changes therein they enable one to work changes intelligently, to work with rules of proportion and measure, making by it a system to better produce a pattern to any form. In fact, one can say it is a trying-on in the production, and will give the experience acquired of the advanced and practical cutter, as well as broaden one's ideas, which requires years of practice in trying-on to find out. Without this many are working in the dark, even with years of practice, repeating the same changes over and over again without the knowledge as to how to correct before they try on what they do after, and that experience should teach.

The formation of this work in all the separate branches has had, before its publication, to perfect it, the personal attention of the author, and by personal solicitation, giving instruction and teaching in all the branches, and having the opportunity, by so doing, to see the advantage of it in working, as well the benefit of the best of criticism on them, and has enabled him to strengthen any weak points, to complete this work for publication in a clear and comprehensive manner as to forms for working out all problems as to their different forms, and with satisfactory results.

This work is arranged as to instructions given in teaching, while all is taught from lessons taken. It would be impossible to impart to any one, in a course of instructions, all this book contains, though nothing to forget in the rules or systems that the eye would not recall. The write-up of explanations, remarks and suggestions would be difficult to recall at all times, as well to think of in giving instructions. Many rules, systems or works on garment cutting will not harm one, as there is some good in all; they will not harm a cutter half as quickly as one bad one, and the more agreeing on the same location or producing of points, the better you can afford their adoption and judge by them if you know it all. The bad ones are as convincing of wrong as the good ones will convince in the right. I recommend all, but more especially this of mine.

The claim for something new in the present age, and also the result of practical experience from the year 1857 to the date of completion to issue for publication, in the year 1907, is the author's reason for writing this book, and during the above time he has had the benefit of experience of many good rules and some poor ones to experiment upon. One who originates surely ought to be able to impart.

This will be the first and final issue of this work in all of the several branches, as the author has intended in the completeness of this work that there shall be no requiring for a second, third or fourth edition. The demand for this work is a guarantee, and has made the supply that governs in all business.

Why it is essential to give the three forms contained in this book for producing a result is, that the beginner will work changes of the practical and experienced cutter intelligently, as no set rule or system of working will produce for the different forms, and in this work you have the foundation of proportion that drafts an artistic and well-balanced pattern with proofs as guide—one that will produce for any form with small changes, and will give by the rules within the rule ones for all separation and points as guide in shaping the scientific art part of producing.

CONTENTS.

Foundation—Rule 1, Draft A, Proportion,	10
Proofs—Foundation Draft of,	12
Sleeve,	14
Measures—To Take and Apply,	16
Measure—Rule 2,	18
Cutaway-Frock—Rule Draft C,	20
Double-Breasted Frock—Draft D,	22
Dress Coat,	24
Raglan—Rule Draft,	26
Inverness—Rule Draft,	28
Shoulder Cape—Rule Draft,	30
Skirt—Rule Draft of Cutaway,	32
Skirt—Rule Draft Double-Breasted Frock,	32
Skirt—Rule Draft Dress Coat,	32
Vest—Reduced from Rule 1, Draft A,	34
Vest—To Take from the Coat Draft,	36
Vest—Rule Draft Proportion or Measure,	38
Vest—Rule Measures to Take and Apply,	40
Scales—To Apply,	42
Remarks—Cause and effect,	47

SYSTEM OF PATTERN ILLUSTRATING—COATS.

Long Neck Form, with collar,	52
Short Neck Form, with collar,	54
Neck Gorge,	56
Erect Form,	58
Stooping Form,	60
Corpulent Form, Sack,	62
Corpulent Form, Frock Cutaway,	64
Corpulent Form, Double-Breasted Frock,	66
Corpulent Form, Dress Coat,	68
Double-Breasted Under Sack,	70
Double-Breasted Overcoat, Sack,	72
Fly Front or Chesterfield Overcoat, with fly or to button through,	74
Drapery—Erect and Stooping Forms, for all Sack Garments,	76
Front Edge, to Tighten,	78
Blade, to Place Seams,	80
Tuxedo, Shawl Roll,	82
Tuxedo, Peaked Lapel, with Collar,	84
Tourist Coat,	86
Paddock Coats,	88
Cassock, with collar,	90

Diagram—No. 1, Explanation From,	92
Seams—No. 2, Side Body center division shape,	92
Back and Side Body No. 3, Lengthen, Shorten and Separate,	92
Whole Back—No. 4,	92
Sleeves and Back—Nos. 5 and 6, Lengthen and Shorten,	92
Skirt Drapery—No. 7,	92
Skirt—No. 8, More Spring after Completion,	92

SYSTEM OF PATTERN ILLUSTRATING—VESTS.

Measures, System to Take and Apply,	96
Single-Breasted, 2 forms of collar,	98
Single-Breasted, without Collar,	100
Dress, Single and Double Breast,	102
Erect Form,	104
Stooping Form,	106
Corpulent Form, with Scale for all,	108
Military, 2 forms of collar,	110
Double-Breasted, one-piece collar,	112
Double-Breasted, three-piece collar,	114
Double-Breasted, Albert,	116
Clerical, Diagram with Collar,	118
Clerical, Explanation Illustrated,	121
Hints and Suggestions,	125

FOUNDATION RULES

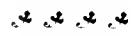

FOUNDATION—RULE 1—DRAFT A—PROPORTION.

FIRST draw line A (construction line), then line B at right angle. Go out from line A on line B to C one-eighth and one-half inch. From C to D one-twenty-fourth. Shape line from line A to D. Go down on line A from line B to line E one-fourth. From line B to line F one-half. From line F to line G one-half. Then from line B to line H the full length of draft. Square out from line A on line E the distance required for width of back and F G H to the full distance required for front edge of draft. Go out on breast line F from line A to I one-third and one-twelfth. From I square up line J above line E one-eighth to K. Then line from K to D for top of back shoulder. Go down on line J from line E one-sixteenth for back notch of sleeve. Go up on line J from I to L one-twelfth. Go out from L to M one-twenty-fourth. Go out on line H to O one-third. Back from O to P one-eighth. Then draw lines from O and P to I for separation of back from forepart. Go up from line G to Q two inches. Then line across lines O and P. Go down from Q to R one-third. (The points Q and R are given as guides in shaping separation of back and forepart, R being the larger point of hip and Q the smaller of waist.) Then divide equally the distance from L to M. From that distance an opening of three-eighths inch to N. From N shape the back to I to Q to opposite of R to O. Shape the forepart from M to opposite Q to R to P. Go out on line F from J to T one-eighth. Establish the center line S by squaring from line B to T and below line G. Go out from line A on line F to U two-thirds. From U to V one-twenty-fourth. From V square up line W for front of arm scye. Go up on line W from V one-sixteenth for front notch of sleeve and from V up one-sixth (a guide point in forming front arm scye). Go out from U to Y for front line X one-half. Square down for line X from line B to Y to line H. From line B go down on line X to Z one-sixth. From Z to AO come in one and one-quarter inch. This will be for collar notch. From AO extend line for button stand BO to line G. Then go out from line A on line B to CO two-thirds, one-sixth and one-twenty-fourth. From CO square a line down three or four inches. Draw line from CO to line E at line A for top of front shoulder line, taking the distance from CO to center line S at DO for the width. From DO go down on line S to EO one-thirty-second. From EO shape to shoulder line. Take the distance of front shoulder width from CO to D, and make the back shoulder width three-eighths inch shorter. As to all seams joining in equal lengths, the front shoulder decreases in length at a seam in, while the back increases the reverse to the three-eighths inch difference from the outside lengths. Then shape arm scye from back width at K to back notch to N to T to front notch. Then from EO to one-sixth and to front notch. To form neck gorge draw line FO from AO to center line S at line B. Then from CO to line FO go one-sixth and line to the one-sixth. Take the half, a one-twelfth, and from that one-twelfth line to the fork where lines cross; from fork go up one-twenty-fourth. Then shape from CO to the one-fourth to one-sixth to AO. To form full length of draft forepart at bottom, sweep at CO from P on line H forward, and (as proof) take length of draft back, and from AO go down that length to whatever point on sweep line style or shape calls for. In shaping front edge of draft, go out one-fourth inch from line X at Y and shape from Z to Y to line G for required style.

All mentions of whatsoever divisions in this, or any part of this, work are those of the breast measurement, and are to be so implied without further mention.

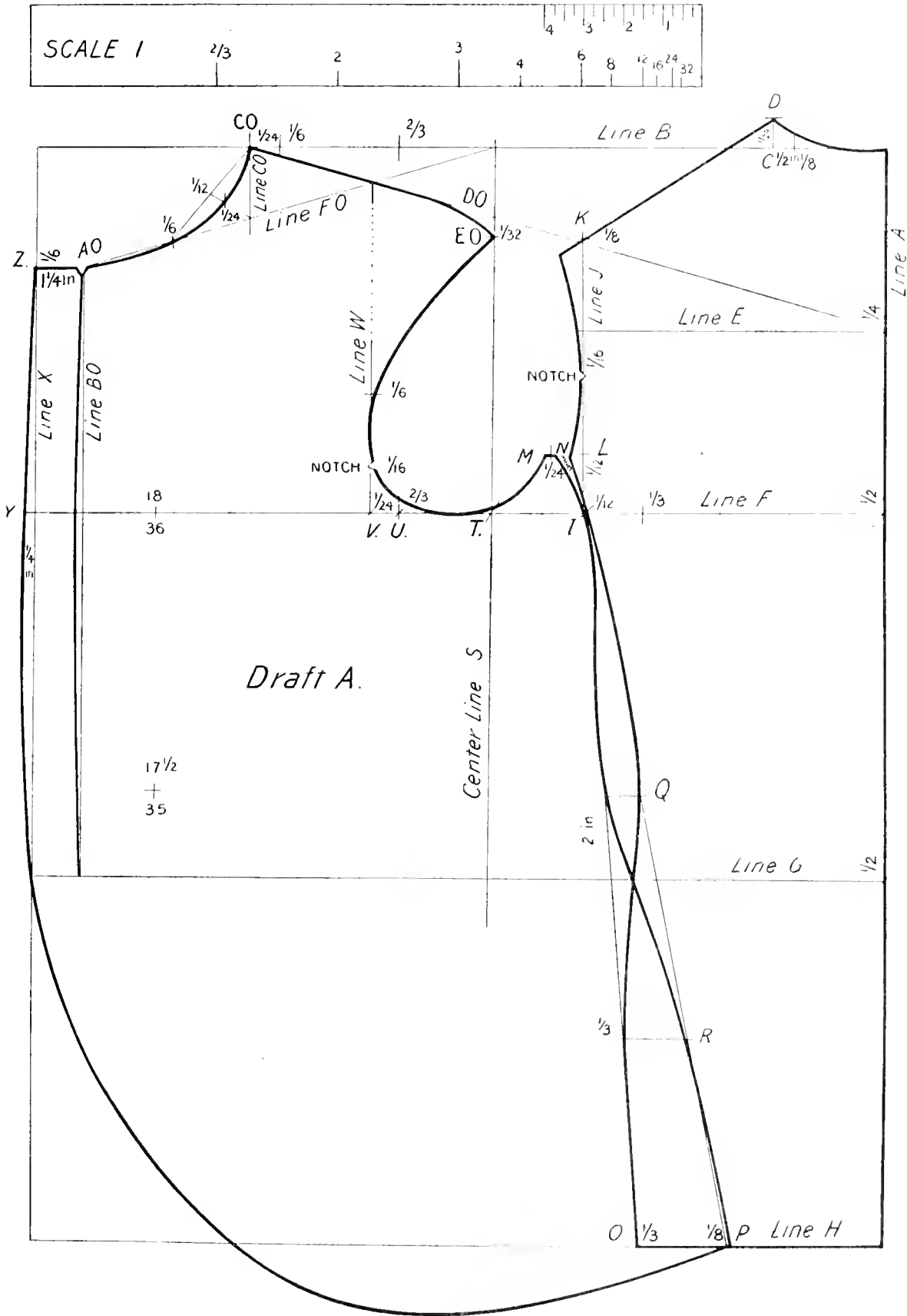

FOUNDATION—RULE 1—DRAFT A—PROPORTION.

DRAFT OF PROOF FOUNDATION.

BY center line S (at T) will be found in following the arrow heads that all points as to connecting go together as one in equal and exact distances, as in proof of each other and by them, proving the center as to right location, and, as will in proof, do all points as drawing in influence one over the other and harmonize in their locations as to being correct.

The shoulder line balance of equal half, also the end shoulder point and the heaviest point of hip, are in line by this rule in ruling, as do many of the other lines, as will be seen in their crossing by points as given, making it in all a self-proving rule, and having principle as a base foundation to work on.

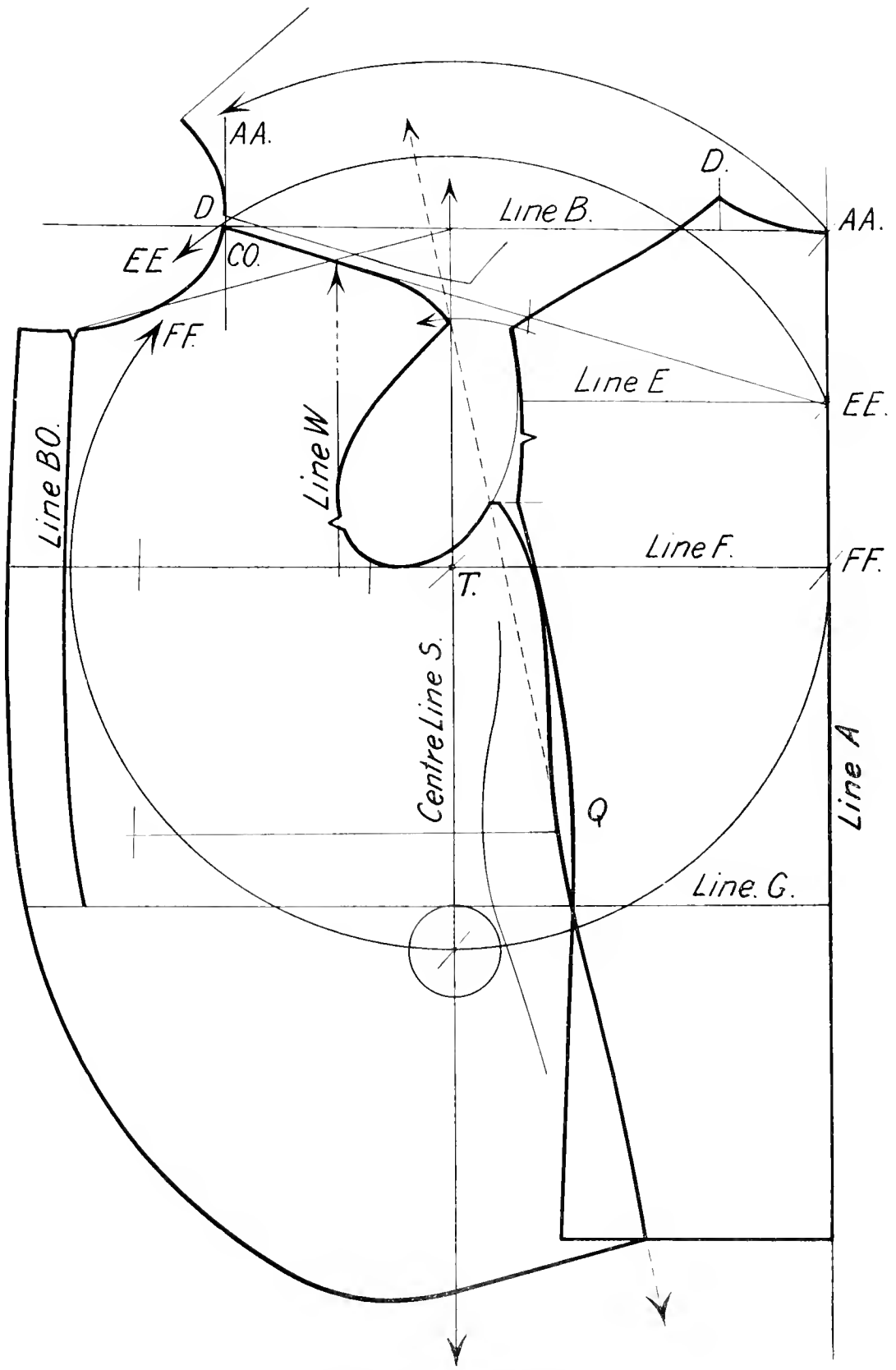

PROOF DRAFT OF FOUNDATION.

SLEEVE.

TO draft a sleeve: If for two parts (top and under), fold the width and length (paper) required for sleeve. Place folded crease from you, using that crease as a construction line, A; from it square and line towards you top line, B; then from line A on line B come back one-third, and from the one-third come back one-eighth. From the one-eighth square and line down line C to full distance for sleeve length. This from line A to C will form one-half width for sleeve. Then from line B at top go down on line C one-twelfth; from one-twelfth down one-sixth, from one-sixth down one-sixteenth; then from the one-twelfth at line C square out a line the distance of one-twelfth. From the one-sixth at line C, square across to line A, marking only on line A for the front notch of sleeve at forearm. From the one-sixteenth at line C square across to line A and line back a distance of one-twelfth for line of under-sleeve depth; then find half of sleeve width at top line B, and from that half distance square down a line to under-arm-sleeve depth for line D; placing now the square as a triangle with point resting down on center line D, with long arm of square to rest and touch at fork of lines B and C at top, and the short arm of square resting and touching the fork of line A and B at top. Then on those triangular lines go in from the fork of A and B on short arm of square one-eighth, and on long arm go in one-sixteenth. Form the top sleeve head from the one-twelfth down on line C by shaping to the one-sixteenth on long arm triangular line; then to the one-third on line B; then to the half center line D; then to the one-eighth in on short arm of triangular line and to the front forearm mark for notch of sleeve opposite the one-sixth on line C. Form the under part (or half of sleeve) from the one-twelfth in from one-twelfth on line C, going down on the triangular line to the point of square on line D, curving a line from it to the one-twelfth in from line A and to the front notch of forearm of sleeve draft, observing in the shaping of undersleeve from the one-twelfth to notch that it conforms to the shape as in front seye to coat draft from U to notch in draft A. In the inseam measure of sleeve length at forearm it is taken from bottom line of armpit to the length required at cuff. Then place the point of square at that distance, resting the front edge of long arm of square at line D at top of line B. By this you will find by the short arm of square the proper shape for bottom slope as well, and at the same time determine and mark the distance for size of cuff by square when in that position. From the width of cuff at bottom take the distance to the one-twelfth on line C, and the half of that will be the elbow location; from that line to the one-twelfth in from line C for under part of sleeve at top, and from elbow line to bottom at cuff width. Then shape from the one-twelfth in from line C to elbow and to full length of outside or back sleeve to cuff width. Cut out draft on the round line of top sleeve head from the one-twelfth on line C to the notch at forearm on line A; then the back line of top sleeve from one-twelfth at line C to elbow and to full distance to cuff width; from that cut bottom shape to line A. Then open out the draft and cut the undersleeve as shaped from one-twelfth in from line C to elbow, and from the same one-twelfth to front arm notch. You now have a draft to place a separation at any distance wished.

If measure is taken on out or back seam for length of sleeve the elbow is then established by it from one-twelfth on line C and to a full distance at cuff; that distance from line A is regulated by style. From the full distance of back seam at cuff width, line to line A, and from that line formed go up on line A one and one-quarter inch and shape from back to the one and one-quarter.

I find the best criticisms on sleeve length favor the taking of inseam as being the most accurate. In using a one-piece sleeve of a half and half, the paper will not require folding, and line A will be constructed in place.

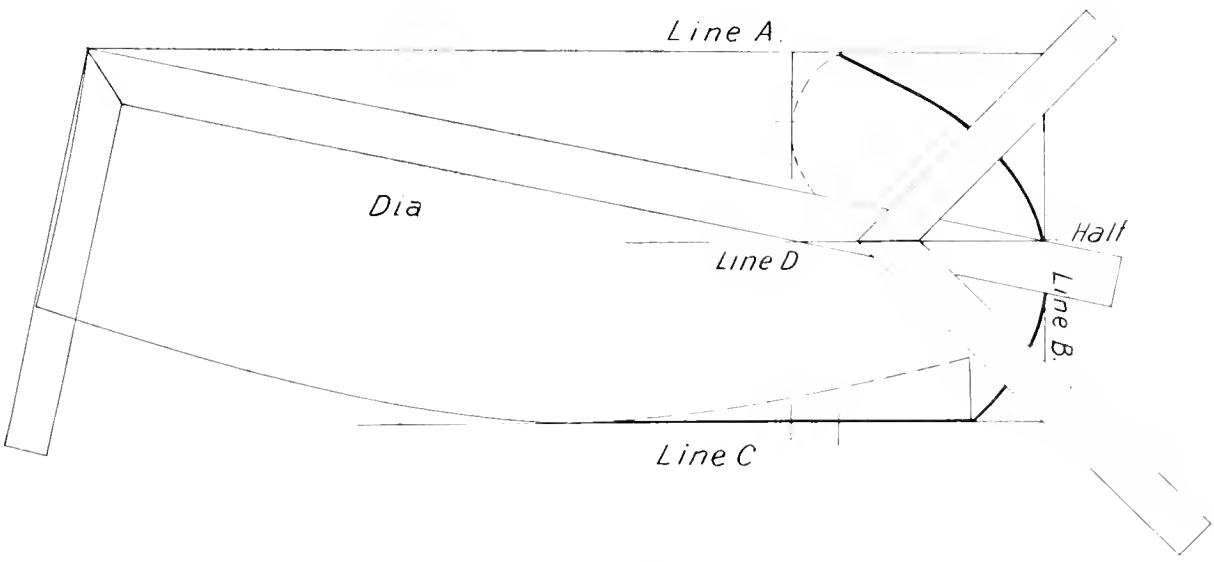
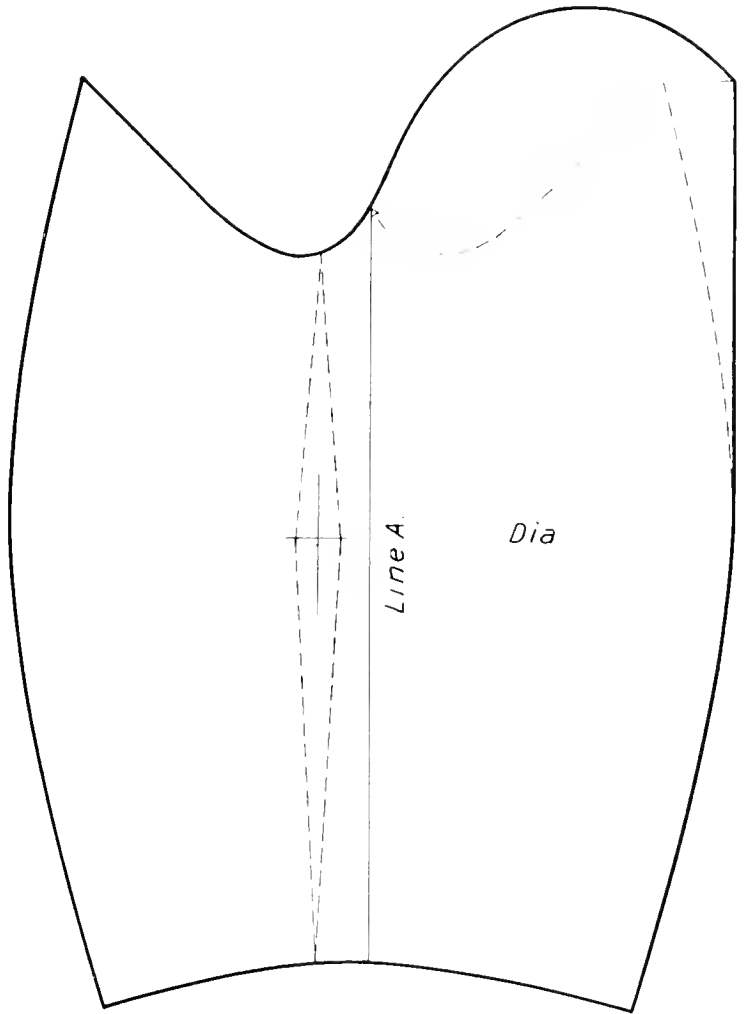
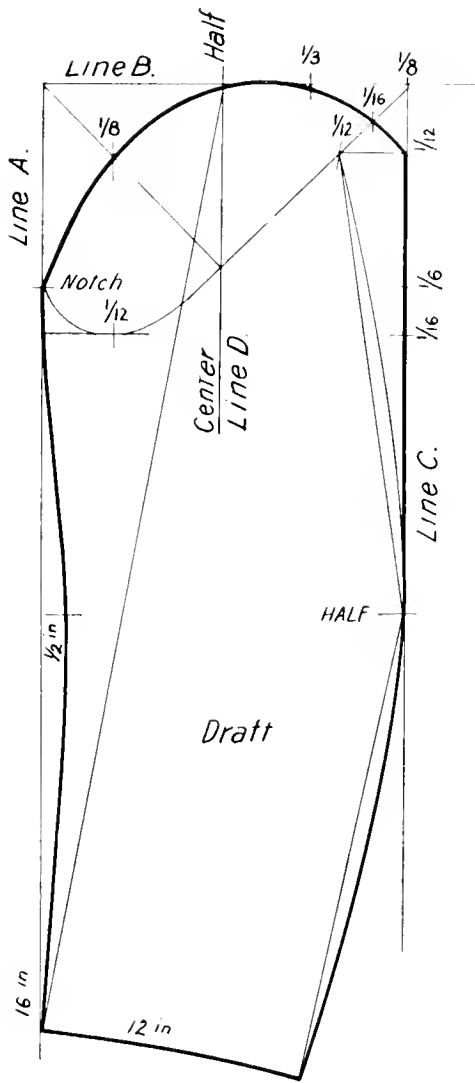

SLEEVES.

MEASURE, TO TAKE AND APPLY— FOR BODY-FROCK, UNDER AND OVER SACK

DRIFT B will illustrate the system of transformation from the ruling principle as governing proportion to the one of measurement as by measures taken to apply, and the transforming by them into a systematic whole as a result, either in drafting or in use of pattern.

First establish point U at front of arm scye, then from U take a line under the arm and over the blade to center of back, marking on the top of it on the blade at back of arm scye and at back center for scye depth and point to apply the measure.

To take the measure: First, taken from top of back (less the amount for collar stand), the height of collar stand must be governed by the form and style of dressing the neck and width of collar fold. This measure extends from top of line B to line F (scye depth). Second, measure from line B to natural waist line Q. Third, measure from line B to full distance of waist style, line G. Fourth, measure from line B the full distance of draft to line H. Fifth measure from center of back to back-sleeve notch. Sixth, blade measure from U to center of back. Seventh, measure from U the distance of sleeve forearm. Eighth, from U to line BO button stand, one-half chest. Ninth, from U to CO, adding to it the distance of back-neck width from line A to C for the full strap measure. Tenth, over shoulder from U to depth of scye establish a center of back. Eleventh, over end shoulder from U to mark on blade at back-arm scye. Twelfth, the full breast. Thirteenth, at the natural or hollow point of waist. Fourteenth, the hip at largest part. To apply measures: if taken over the vest, all seams to be used require their amount to be added to the measures taken; if over the coat, their allowance will be made by the extra amount of difference in the two measures; if for overcoat measures taken over the vest, one-half inch and seams should be added to depth of scye; to front and back shoulders, to blade, to breast, and to front point CO. If taken over the coat the seams added to measures will govern. In the use of patterns, take one two sizes larger if the measure is taken over vest. If over coat, take the size measure calls for and add to it all seams. In applying measures for any changes that form or affect measures, observe those that have previously been given and those that will be hereafter systematized in diagrams or explanations. The only difference in taking or applying measures in a body frock and sack is omitting the full distance of waist style in the sack that is used in the body frock. This illustration and the one of how to apply and draft by measure will suffice for all in their different methods of reaching the one result, either by proportion measure or the use of one's own or other patterns.

Point U can be established either by square, stick, fingers, or in any way to form a starting point to take and apply measures therefrom. It makes no difference how the base is found for starting, but it does make a great difference whether the base is rightly located, and a small outlay for an appliance that will stay in place and allow the taking of all measures at and from the located point will well repay the expense. If there is any necessity for taking measures other than as a guide and assistance, with good proportion and good judgment, it is surely essential that they should be as accurately taken as possible, and always from the one point, as they are often misleading at the best. The close and even measure is the better one to take, as you can always determine by it what allowances to make, whereas in using the loose or slack measure you cannot always recall how it was taken.

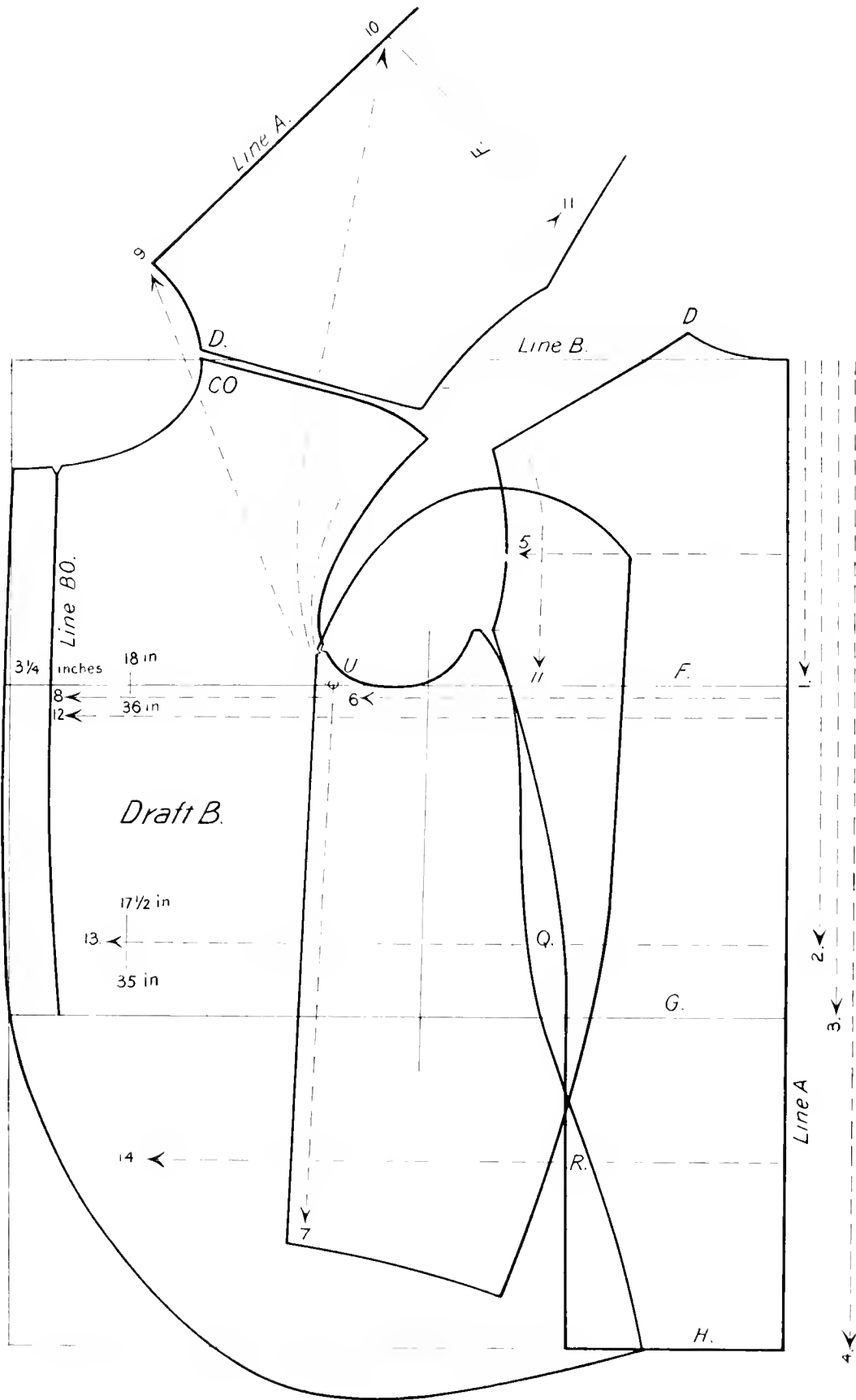

MEASURE, DRAFT B.—TO TAKE AND APPLY.

MEASURE—RULE 2.

TO draft by Measure, the same rule formation as Foundation Draft A will govern, with the following changes: The depth of scye measure with a seam added from line B on line A will establish line F; then from line F one-fourth up will establish line E; the distance from line B to natural waist by measure will establish line Q, and this line is determined by the hollow part where back curves in most above the point of hip bone; the distance of measure from line B to full length of waist will establish line G; then the full distance of measure to line H. To establish width of back go out on line F to I the distance of measure taken, adding to it all seams to be used. To form back part of scye use all the governings on line J as in Foundation Draft A. Draft now the back as in Draft A. To establish front of scye, go out from line A on line F to U the distance of measure taken, with all seams added; extend from U to V one-twenty-fourth; then draft line W as in Draft A. Establish center line S at T by the half distance from I to U and draw line S as in Draft A; to establish front of draft go from line A on line F the distance of one-half the full breast measure taken, and from that one-half distance extend out to Y on line X three inches and form button stand as in Draft A. The front shoulder-point CO is located by the back as to shape and form at lines A and B. Draw the line at CO above and below line B, as this line is to be used up and down to locate the required strap. Measure distance as taken, and the depth of neck gorge a one-sixth down will be governed up or down by and from the point this measure establishes. To find that point take the distance of top of back from line A to D; place that amount of distance at U, with it extending to and on the line at CO of a distance of the strap measure taken; then from the point of that distance either down or up draw a line forward to X, the front line of draft, and that will form a new line B from CO only to line X. For all other measures taken and to be applied see Draft B of illustrated measurements. In that I give all the essential ones, how taken and applied. It can be used either in drafting by rule or in the system of pattern changing; any known measure can be added or applied to this system. Before applying shoulder measures I deem it well as a guide to draw a line for top of point shoulder from CO (as located by strap measure) to line E at line A, as it may assist in governing judgment better than measure taken to produce a good line for shoulder shape. The front shoulder width in measure-draft is governed by the back and requires to be three-eighths-inch longer than the back on distances of top lines. The shapings of the front scye and all shapes to be the same as in Draft A, using the same numbers and proportions not given in this Draft B. The measures for Body Frocks are the same as the Sack, only to add the full or style length of waist.

CUTAWAY FROCK—RULE DRAFT C.

THIS draft C differs from the Under Sack Draft A only in separating of back, side body and skirt, and the taking of full-length distance to G. To draft back, go in from line A on line G three-fourths inch to GO, and draw line from lines A and B at top of back of neck to GO, and from GO square line to line H the full distance of skirt. From GO go in to HO one-eighth for width of back at the tack. From HO square line to line H. Then draw a line TO from center line S at T on breast line F to line A at line E. Go on that line TO from center line S at T one-fourth. Go from center line S at T on line F one-fourth and one-twenty-fourth. Draw line from one-fourth and one-twenty-fourth to HO. Then from I on line J go up one-sixth. From one-sixth go forward three-eighths inch. From the one-sixth up go up an opening of three-eighths inch. Go in on line G from HO to IO one and one-half inch. Then shape the back from the three-eighths inch opening to the one-fourth on line TO. From that one-fourth to the one-fourth and one-twenty-fourth on line F, and from that one-fourth and one-twenty-fourth to HO. To form side body, shape from the three-eighths inch forward from line J to the one-fourth on line TO, from that one-fourth on line TO to the one-fourth and one-twenty-fourth on line F, from that one-fourth and one-twenty-fourth to IO, extending the shape below line G a distance of the measurement of back and seam added of shape to JO. From JO shape to center line S at line G. Take out from center line S at line Q three-fourths inch by three-eighths inch each side and shape separation from T to each the three-eighths inch, and to line S at line G; then for length of front forepart go down from line G on line BO one-sixth. From line S shape to the one-sixth at line BO, from G at line S go down one-half inch. Then shape top of skirt from JO to the one-half inch opening from line G, and from that to the one-sixth on line BO. To form back of skirt and spring, go back from the inside pleat line on line H one-twelfth. Draw line from that one-twelfth to JO. From line Q go down one-third. From that one-third go back one-twenty-fourth. Then shape from JO to the one-twenty-fourth and to the one-twelfth at line H, making skirt a full seam longer. To draft by measure is simply to apply those that are taken, and by them establish lines and points they designate in place of proportion, showing by the rule of proportion how much the measures taken differ from it and the system of changing one form to be applied to another. The governing of all other points excepting those located by measures to be observed as in proportion in drafts A and B.

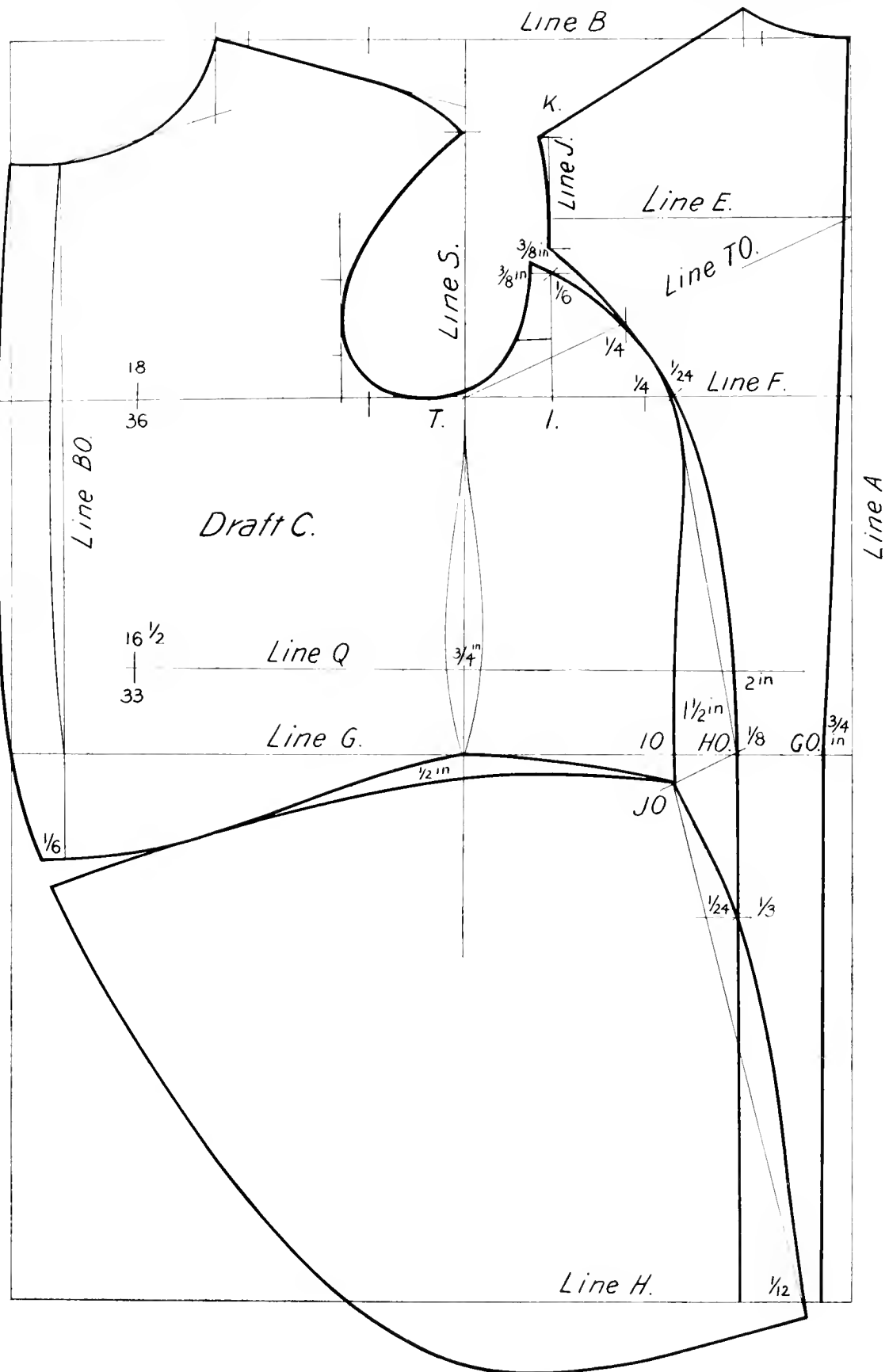

CUTAWAY FROCK—RULE DRAFT C.

DOUBLE-BREASTED FROCK—RULE.

THIS draft D differs only from the single-breasted draft C in the formation of the front observing the same rules that govern in each the proportions and measures, as given in drafts A and B. To draft the lapel, go forward from line BO on line F one-quarter inch, then shape from point AO to the one-quarter inch, continuing the same to line G and to length of forepart that joins skirt at the one-sixth down from line G. Make width of lapel in prevailing style (allowing for two seams one-half inch), width usually from two and one-half to three inches. From AO go forward an opening one-half inch, and from that one-half inch opening shape to the one-quarter inch forward from line BO at line F.

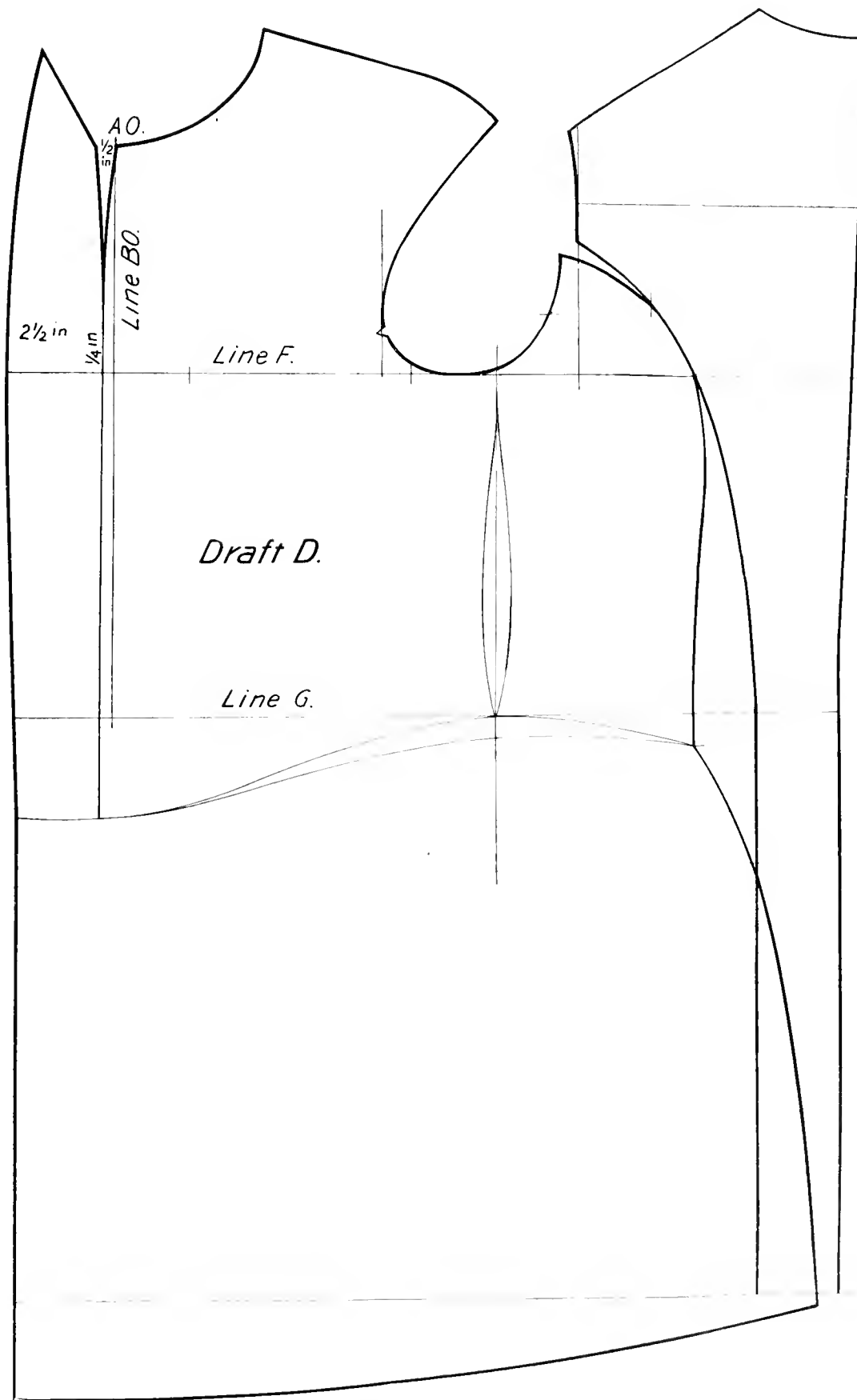

DOUBLE-BREASTED FROCK—RULE.

DRESS COAT RULE.

THE Dress Coat differs only from the single-breasted cutaway Frock Draft C or the double-breasted Frock Draft D by the formation of the front and skirt; all other points in drafting to be governed the same as in Drafts C and D.

The forepart from line BO on line G is reduced one inch. Then shape front the same as in D. B. Frock to line F, and from that to the one inch reduced from line BO and to length of waist. To form lapel at waist, go forward one-half inch; from that make width of lapel as to style and shape as in D. B. Frock, Draft E.

To form skirt by coat draft, go down from the length of forepart at front one and one-half inch, or as to skirt rule; then from skirt line established at center line S at hip, shape to the one and one-half inch opening. Make the depth of skirt front two inches or as to style and size of draft; then place square on line E of skirt at the one-third, and by this line square and line forward a distance of one-half the breast measure; then from the back of skirt line H go forward one-third. From the one-third draw a line to and by the one-half at L. Then from the top line of skirt make the distance to L three inches, or as style and form require, and from that point line to front depth of skirt established. The dress skirt, for the reason of the one and one-half inch opening or drop from forepart at the front, will require that amount added to the back of skirt on line H. The one and one-half inch opening more or less is for the purpose of drawing in the edge of skirt and conforming it close to the thigh, avoiding fullness at point L.

The reason of the separation of the body and skirt at waist line of one and one-half inch in closing up, it will take that amount from the spring at bottom; thus it will require that amount added to it and the same amount taken from the front at one-third.

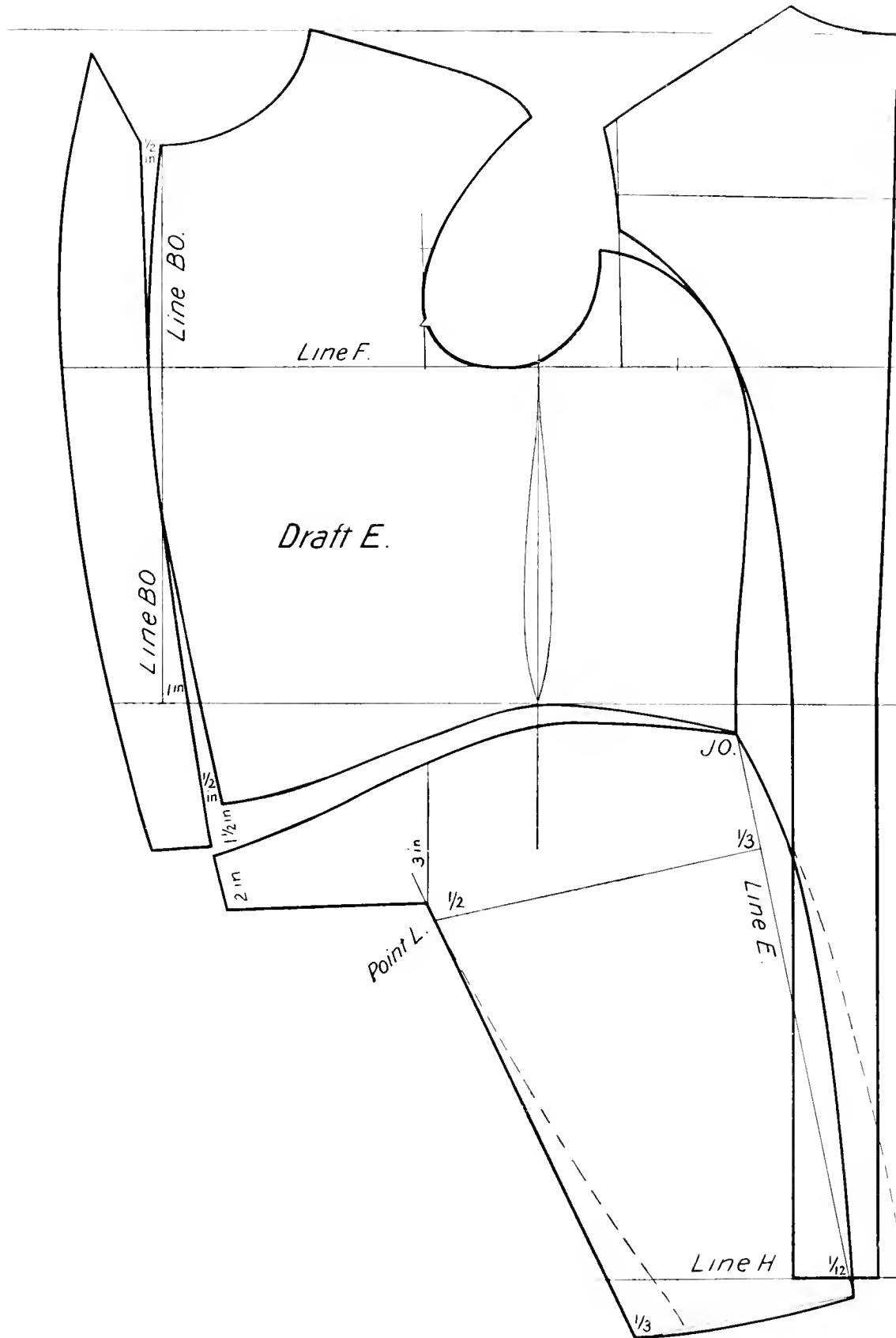

DRESS COAT—RULE.

RAGLAN—RULE.

THE Raglan is produced from the same rule as Coat Draft A, with the following changes: In producing this or any draft other than the regular standard ones, I advise first the formation of a regular draft (of whatever denomination may be required), as by so doing you can better determine the changes and variations in shaping to please the eye, as in this garment the lines have much to do with its effect. It may be well to mention here that the above can be applied in all productions with very good results. This draft differs from the standard in that the shoulder lines are established as wanted, and the sleeve part of shoulder made to conform to their shape. To make the changes from the regular standard draft A for the back top shoulder line, draw a line from center line S at line B to line F at line A. Go on this line from center line S (at line B) one-fourth. Then shape from D to the one-fourth to line E and to back scye notch. To form front shoulder top line, draw a line from center line S at line B to line F at line BO. Go on this line from center line S (at line B) one-fourth. Then shape front shoulder from CO to that one-fourth, and to the one-sixth on line W. The remainder of front and back of scye formation as standard (Draft A). The above points given have been well tested and found good in their governings; while any one established point will not conform to all eye criticism, and styles changing, they allow for any change from them, and to do so have the sleeve top part of that amount to conform with any changes that may be required either for fullness, height of shoulder or shaping. To draft the sleeve: Produce the same draft as in standard sleeve rule draft, then square up from line B at center line D (in sleeve rule) a line the distance of one third, from that one-third go forward one-twelfth, then go in on triangle line from the fork of lines B and C one-thirty-second, and from the one-twelfth down on line C shape to the one thirty-second and to the one-twelfth out at the point of top sleeve. Go in on triangle line from the fork of lines A and B one-sixteenth, and from the notch at forearm of sleeve shape to the one-sixteenth on triangle line and to the point at top of a one-twelfth out from center line D. This will form the sleeve top. In forming sleeve top for Raglan it will be of great assistance in the formation of shoulder in the make up to place a thread mark in the sleeve head, which should be the same shape as in the standard. For extra drapery or spring, go from line A at line H one inch; as to H, the full distance, and that on a basis of a thirty-eight inch distance of a draft; line from the one inch out from line A to the top of line A at line B. If more length is required, this line, if extended by its angle from the thirty-eight-inch distance, will govern for any length required.

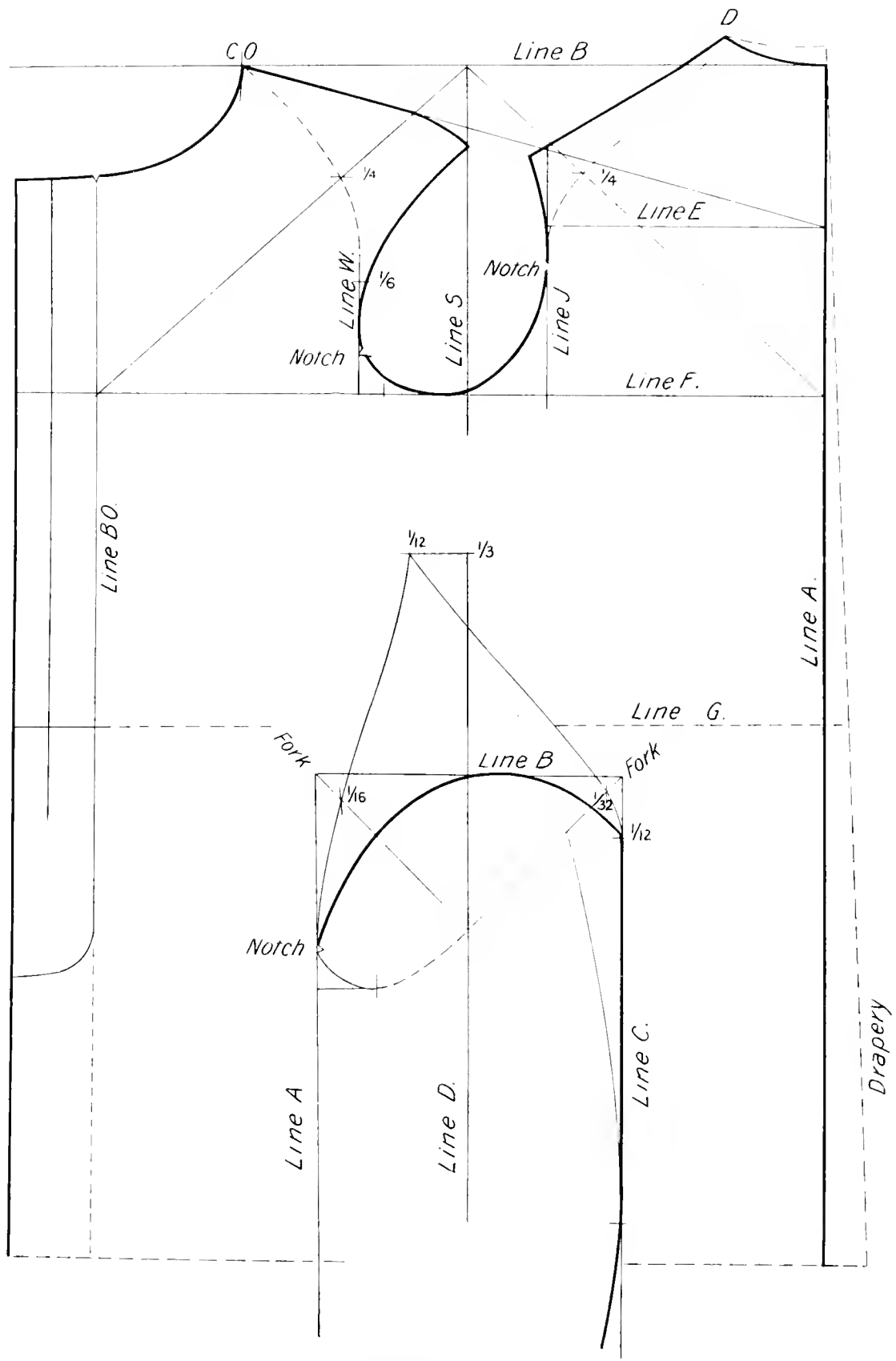

RAGLAN—RULE.

INVERNESS—RULE.

IN this draft, like that of the Raglan, there is no better way than to make the changes by and from the regular standard coat draft A, as, in having that before you, you can best observe and govern a draft of changes; the changes to be observed as follows: To form the back, come back from K one-sixteenth, then from D shape the top back shoulder to the one sixteenth, to line E, to M, and from M a straight line the distance to line H for separation of back and forepart. Go down on the separation line from line F one-fourth to notch one (for extra scye depth). From the separation line come back on line H for the spring one-sixth, and from the one-sixth line to notch one.

To form front shoulder and the scye, reduce shoulder width from DO one-sixteenth, then from the one-sixteenth shape scye to the one-sixth on line W to V, and to the one-fourth on separation line notch one.

To form the cape: Square back from line A at breast line F an extended line the distance of one-fourth, draw line FO from center line S at line B to the one-fourth, extending one-sixth, or to any distance required for cape length or depth. Go on line FO from center line S at line B one-eighth, then from the one-eighth on line FO shape to line E at line A and to full distance of cape length. To form circle of cape at bottom, take the distance on line FO from the one-eighth to full length, and make that on the front from Z down on line X equal it. Then go out on line X to GO one-twelfth, and line from GO to Z for the front. Shape now the bottom from the full distance of the back to R to GO (R being located as in standard Draft A), the notches one and two on line formed by line FO as from the one-eighth to the full length equals in joining in going to place those of one and two on separation line of back and front.

To produce cape: Place another paper under the draft of the required size and take an impression from it, tracing the following line: From the one-eighth on line FO to full distance of back depth as shaped; from the one-eighth on line FO to EO, from EO to the one-sixth on line W, then trace the front shoulder and neck gorge as shaped, then from the one-sixteenth on the top front shoulder to the one-sixth on line W. Then the curved line to the full distance at the one-sixth on line FO to R, to GO, and from GO to Z. Now take out the paper and cut out by the impression marks, notching as above mentioned. The drapery and spring is the same as in the Raglan draft. The front of drafts in Coat and Cape are regulated by the styles that govern.

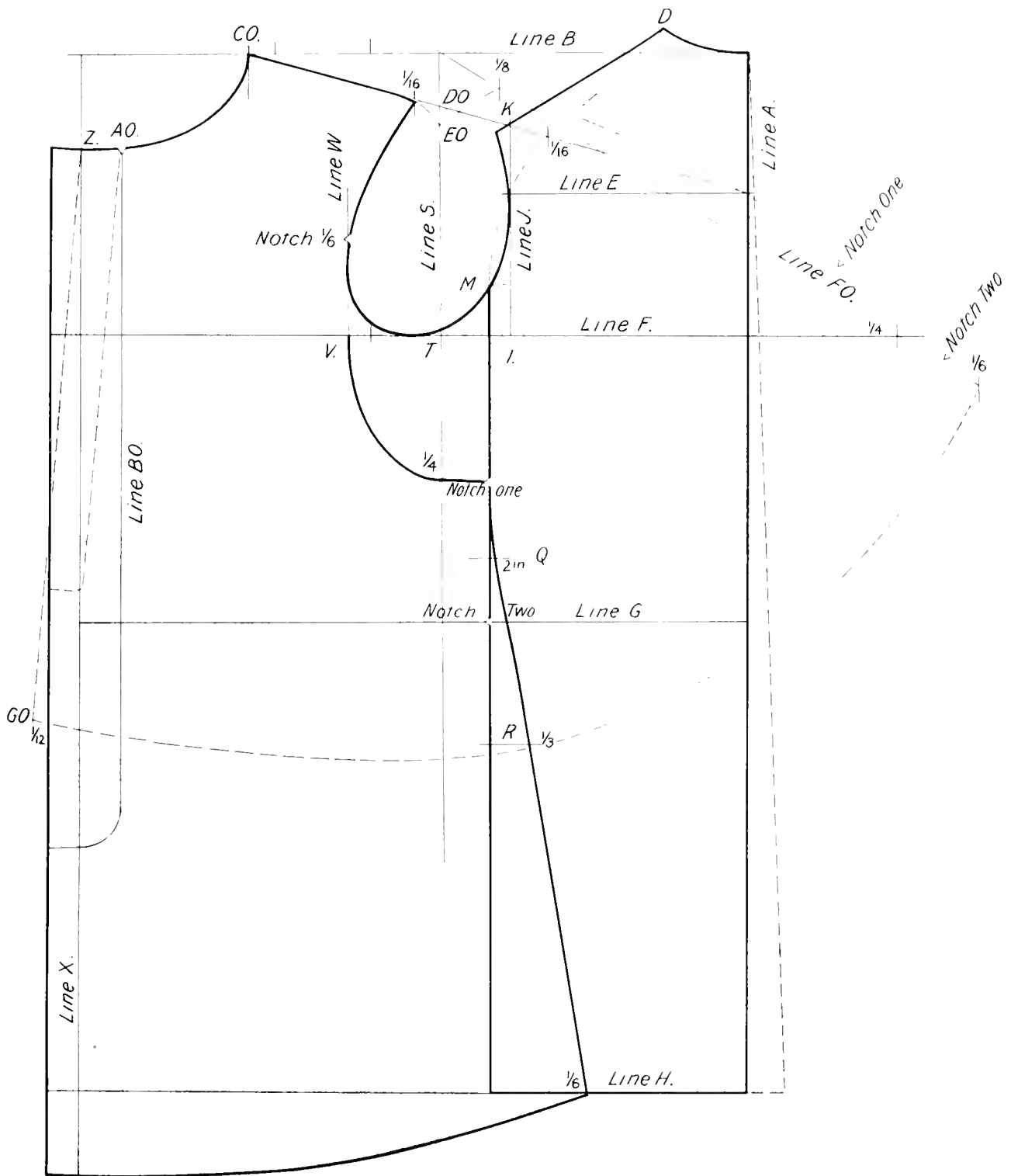

INVERNESS—RULE.

SHOULDER CAPE—RULE.

CONSTRUCT line A and square out line B by and from it; go down from line B on line A one-fourth to line C; go down from line C on line A to shoulder line E one-fourth; from line E go down to shoulder line F one-fourth, go out from line A on line C one-eighth and one-half inch; from that go up one-twenty-fourth to D, then square out lines C, E and F the full distance of long arm of square; go out from line A on shoulder line E one-half, from the one-half square up line G to H on line B; go up on line G from line E one-eighth to I; from I draw line J to D; go from I one-twelfth on line J; from the one-twelfth go up one-thirty-second from line J; then shape from D to the one-thirty-second and to I; go up on line G from I one-twelfth, from one-twelfth come back one-thirty-second; then shape from I to the one-thirty-second and to H on line B. This forms the back and front shoulder lines as going together. Go out two-thirds from line A on line F, from the two-thirds go one-twenty-fourth to K, then place long arm of square with the front edge at K and I, and form line L from line B, through and past them the distance of long arm of square; place square on line I, with point of short arm at line E and go forward one-half on line M; extend three inches from the one-half to N, and one and one-fourth inch from N to O, then go out from line A on line B two-thirds to P, from P one-sixth, from one-sixth to AO one-twenty-fourth; from P go down one-sixteenth; then shape from H to one-sixteenth down from P and to AO, from AO line BO to N, and extend the distance required for button line. From and by this line BO square up from AO the distance of one and one-fourth inch to Z; then from Z draw line X to O and to full distance of front edge of cape draft. To form bottom shape sweep from H on line B by taking the distance from H to full depth distance in back, and sweep from that forward to line X at front edge of draft; after taking this sweep add to the depth of back one-sixth, and from that one-sixth re-shape to line L. To take and apply measures: The shoulder measure is taken to, and applied on, line E. Take measure around the body at a straight line around the breast and back or the arm below end of shoulder bone at fullest place on arm. This will give the required number of square scale divisions to be used. If taken over vest, use one of two sizes larger. If over the coat, use as to the measure. To apply measure in proof, go from line A on line E to line L, and from line L on line M to a distance of one-half the full shoulder measure taken, and from that one-half amount extend three inches to N, and from N add amount of button stand, if any is required.

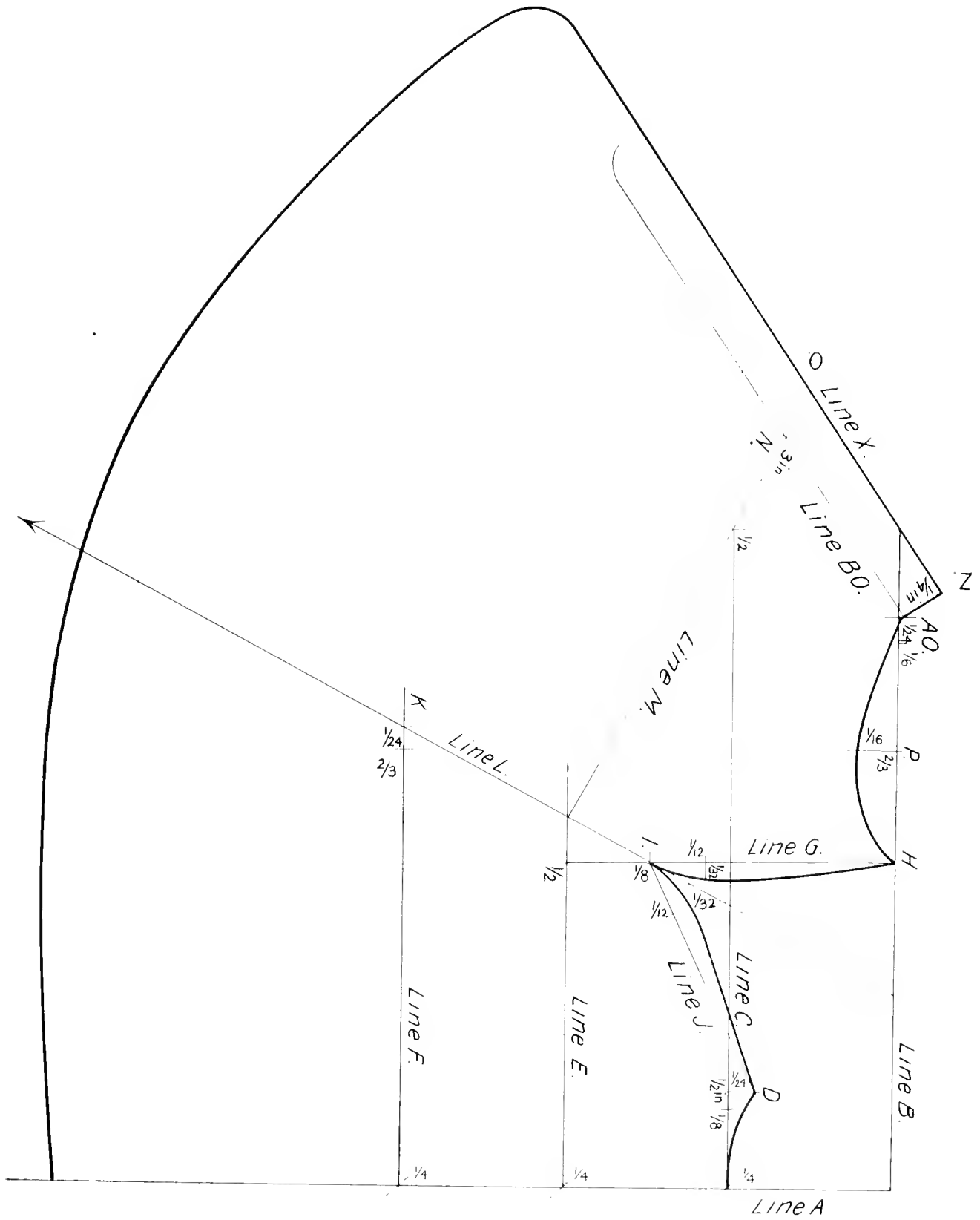

SHOULDER CAPE—RULE.

SKIRTS—RULES: D. B. FROCK, DRESS, CUTAWAY.

D OUBLE-BREASTED Frock Draft—To draft this skirt separate from the coat, establish lines A and B. From line A on line B go in one-eighth to C. Draw a line E from C to the full distance of skirt length to line D; then go down from line B on line E one-third less two inches. From the one-third come back from line E one twenty-fourth. Then shape the back skirt from C to one-twenty-fourth and to full distance to line D. Take the amount of distances of the side body, front and lapel, and make the width of top skirt to F equal to it. From F go down on line X to G one-sixth; go forward from C on line B one-fourth and one-twenty-fourth, and shape from the one-fourth and one-twenty-fourth the top of skirt to G. Go down from line D on line X one-sixth or take length of back skirt and make front of same distance. The Dress skirt draft formation is the same as D. B. Frock with exception of the following changes: From G to H an opening of the one-sixteenth, from H to I width of front skirt one-twelfth. Then place square on line E at the one-third and by this line from one-third, square line forward a distance of one-half to J and from J line to I on front line X. The opening of one-sixteenth from G to H is to make skirt at J conform more closely to the thigh at that point, avoiding fullness, and for the reason of closing that opening of G and H it will require that distance to be added to the spring from line A on line D.

The Cutaway Skirt Draft differs only from the Double-Breasted Frock in the formation of shape from G. The remarks for spring on the Dress Coat Draft will apply as well on all skirts that cause of form requiring the taking any amount from G should apply, as in dress draft illustration, except in the stooping form; then it may require it to take from the amount of spring.

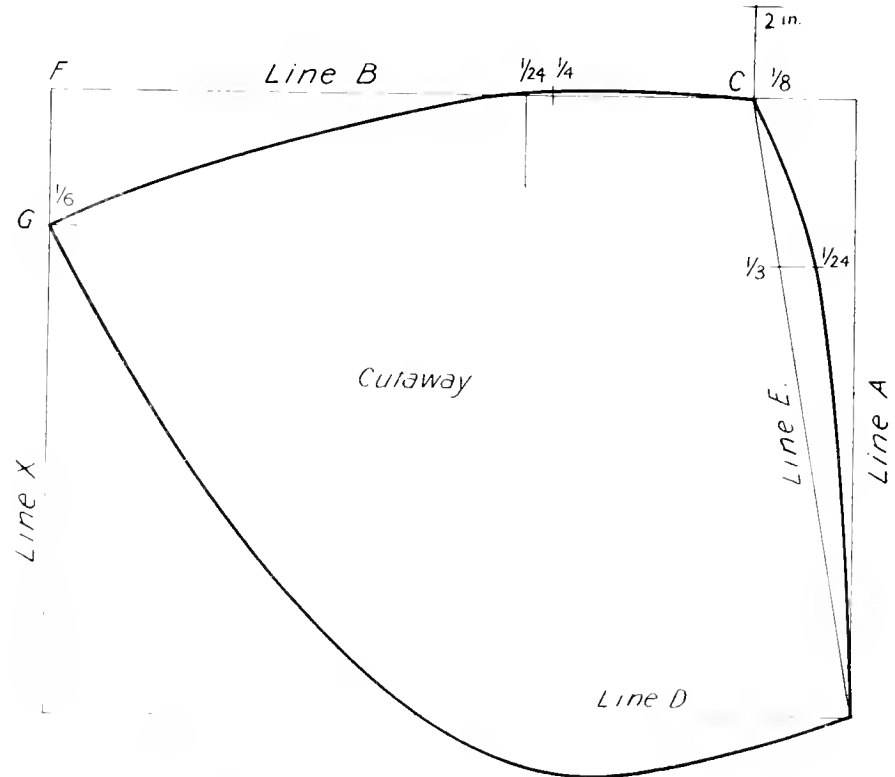
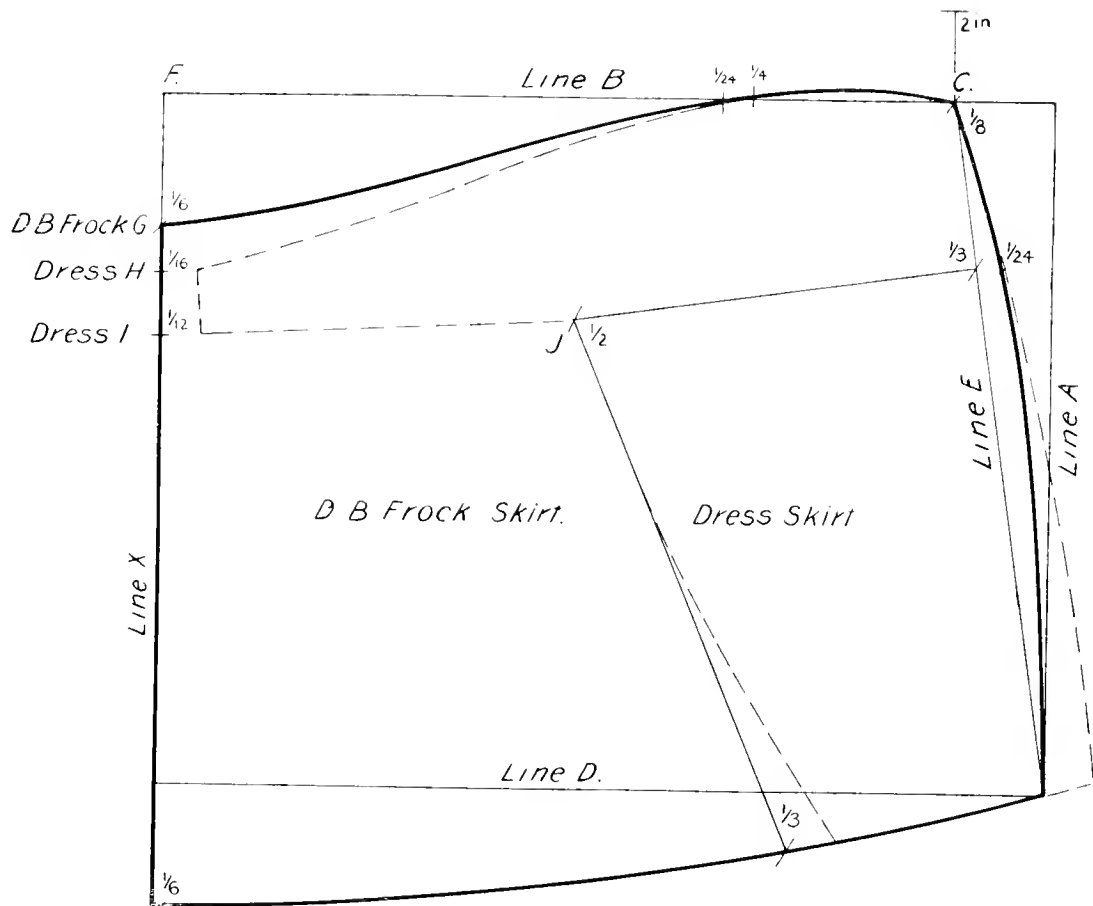

SKIRTS—RULES: D. B. FROCK, DRESS, CUTAWAY.

VEST REDUCED FROM RULE 1, DRAFT A.

THE construction of this vest draft is the same as the coat Foundation Draft A, with the exception of the changes in reduction and points left out not required, while all can be used if desired.

First draw lines A and B, establish points C, D and CO; lines E, F, G and Q; point I and T, line J, point K. Draw line from K to D, establish center line S and points U and V, line W, lines BO and X; take half the amount of coat-button stand for vest. The measure applied will govern opening and length of vest front. Use the same button-line BO in vest as in coat draft. The half of coat-button stand will be the front-edge line of vest. To reduce go forward on line F from center line S at point T one-twenty-fourth, from one-twenty-fourth square and line down from line F to and below line G a distance of one-twelfth. For proportion, go down from line G on front edge of vest one-fourth or as measure taken; and from that distance (one-fourth or measure) line back to the one-twelfth below line G. From line F at point T go down on center line S three-eighths inch, at Q take from center line S for shape one-half inch and from forepart line opposite Q one-half inch; go down from one-twelfth down from line G three-eighths inch. Shape the two side separations of front and back from line F to limit of draft; draw line from the distance of one-twelfth and three-eighths inch below line G back to line A, go in from line A on line G three-fourths inch and shape back from line F to full distance of back length. To reduce shoulders, go in from points of the end shoulder-line widths one-twelfth and shape for arm scye; the back from the one-twelfth to I and to the three-eighths inch down from line F; the front from the one-twelfth to line F at U, advancing three-fourths inch more than coat from line W.

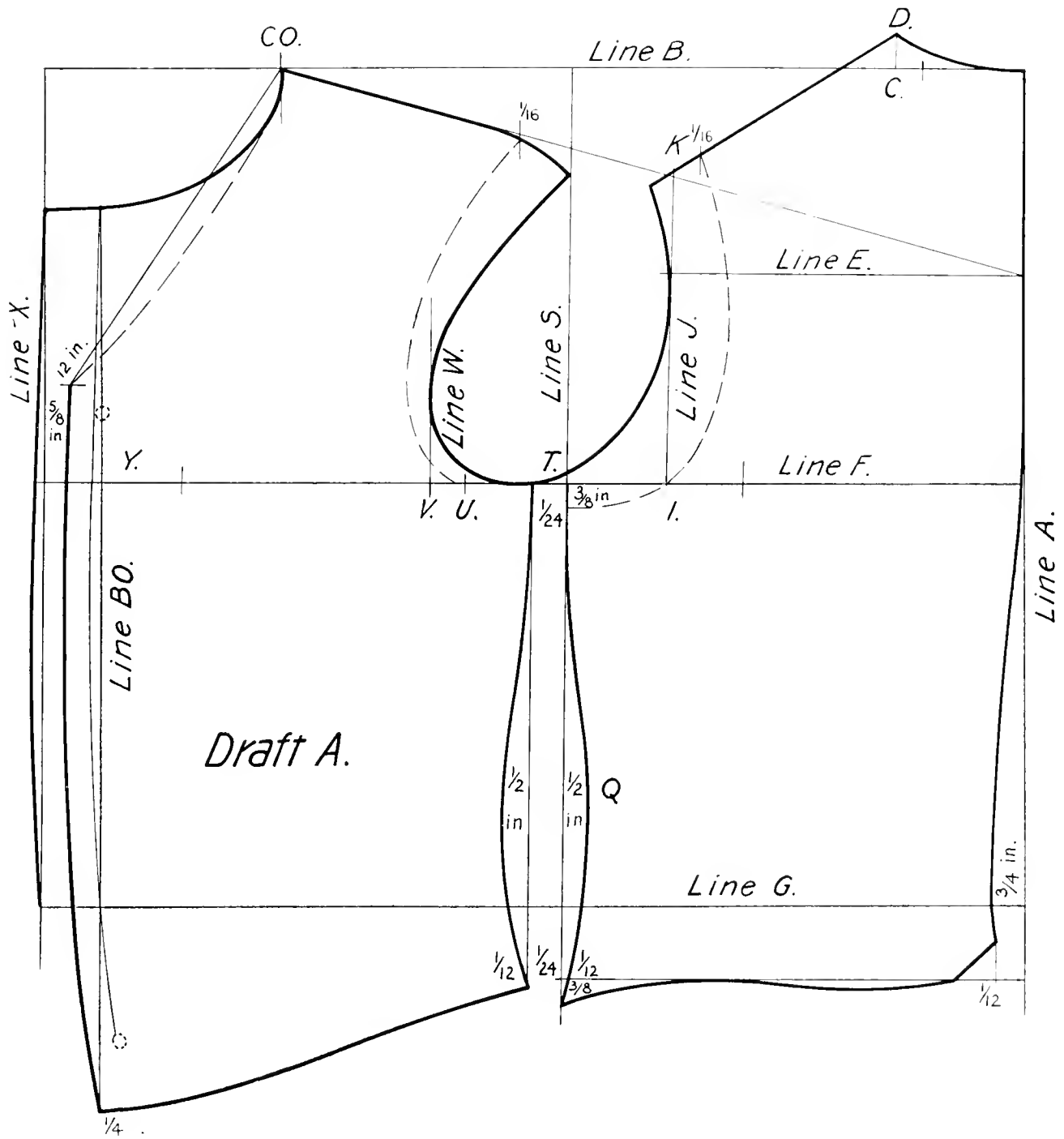

VEST REDUCED FROM RULE 1, DRAFT A.

VEST-TAKE FROM THE COAT DRAFT.

A VEST draft taken from coat draft is the most accurate and simple method of producing a vest draft. To do so, before cutting out the one of coat, place under the draft for coat another piece of paper to extend under a distance for length required for vest, then tracing by heavy marking or tracing-wheel the lines of back and front, top shoulders, arm-seye, breast, waist, button-stand and the center line; then take out the under impression and make collar opening and full distance of front as measures dictate. At center line the required distance below waist line G and all other changes as in vest draft given. In this system of working out a vest problem it gives the exact points and all changes in shaping to conform to the form. Do not go below the breast line in forming arm-seye, as the vest shoulder draft, being the same as coat, will permit it to drop at armpit the distance required in the difference of vest over skirt that the coat will take over vest with make up. In this problem, if coat is right the vest will be, and if any changes are made in coat you will know what are required for vest as well by this system, which will make a saving of time.

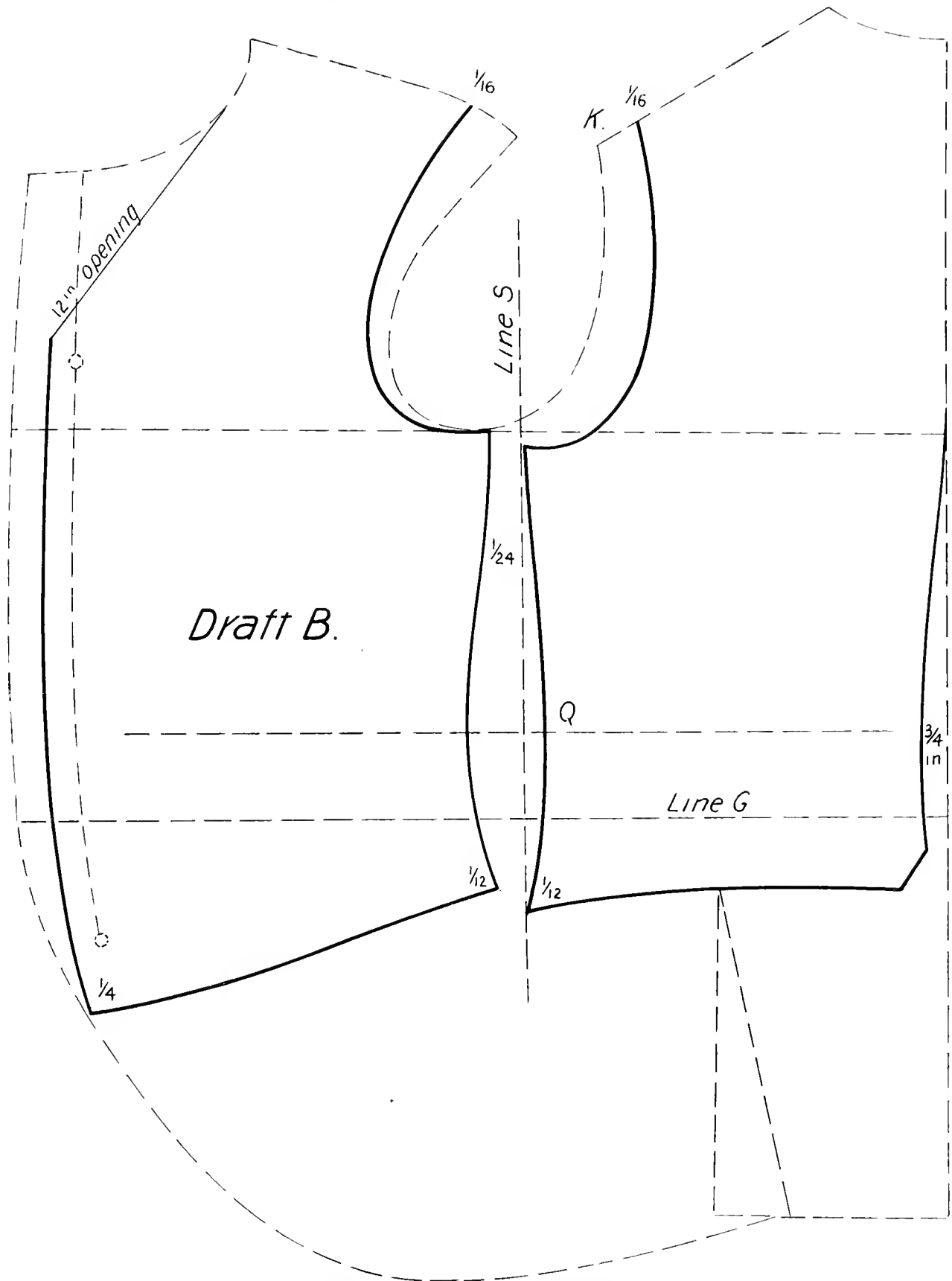

VEST—TO TAKE FROM COAT DRAFT.

VEST—RULE DRAFT—PROPORTION OR MEASURE.

IN giving this draft of proportion it is to show the principles on which this rule is formed, so that you can from it work intelligently any problematic changes with some degree of accuracy, as proving by the different methods and systems the producing of one and same results as a fact. To form this draft, establish all points and lines the same as those used in vest drafts A and B, with the following exceptions: In going out from line A on breast line F, go a distance of one-third for width of back for point I, line J and point K. From line J for center line S go forward one-sixth. For front of arm scye, point V and line W, go forward the same as in draft A and B, then go out from line A on breast line F the half of full breast measure; from that distance of a half go forward two inches; from the two-inch, five-eighths inch; the two inches out from the half breast distance will be the button stand line BO, and the five-eighths inch the front-edge line of draft. Take out the one-twenty-fourth reduction from center of draft, same as draft A and B. Shape the back for arm scye from K as draft A and B, making the front shoulder at top width equal in distance to that of back. The remainder of this draft the same as in draft A and B.

In changing the above to measure draft, locate lines, points and shapes the same as in coat measurement drafts of changes so far as required to produce vest draft, leaving out unnecessary workings of coat draft not used in the vest draft. Take out reduction at center of one-twenty-fourth, the same as in A and B; measures taken and applied will govern width of back to line J, and that the shoulders, blade, scye and all measures govern as in draft A. The width of a vest shoulder is mostly governed by one's judgment as to preference. I favor the wide, as it helps support the coat. The opening at front and length is governed by measurements taken. The double-breasted drafts are best explained by diagram illustrations in the branch of system illustration.

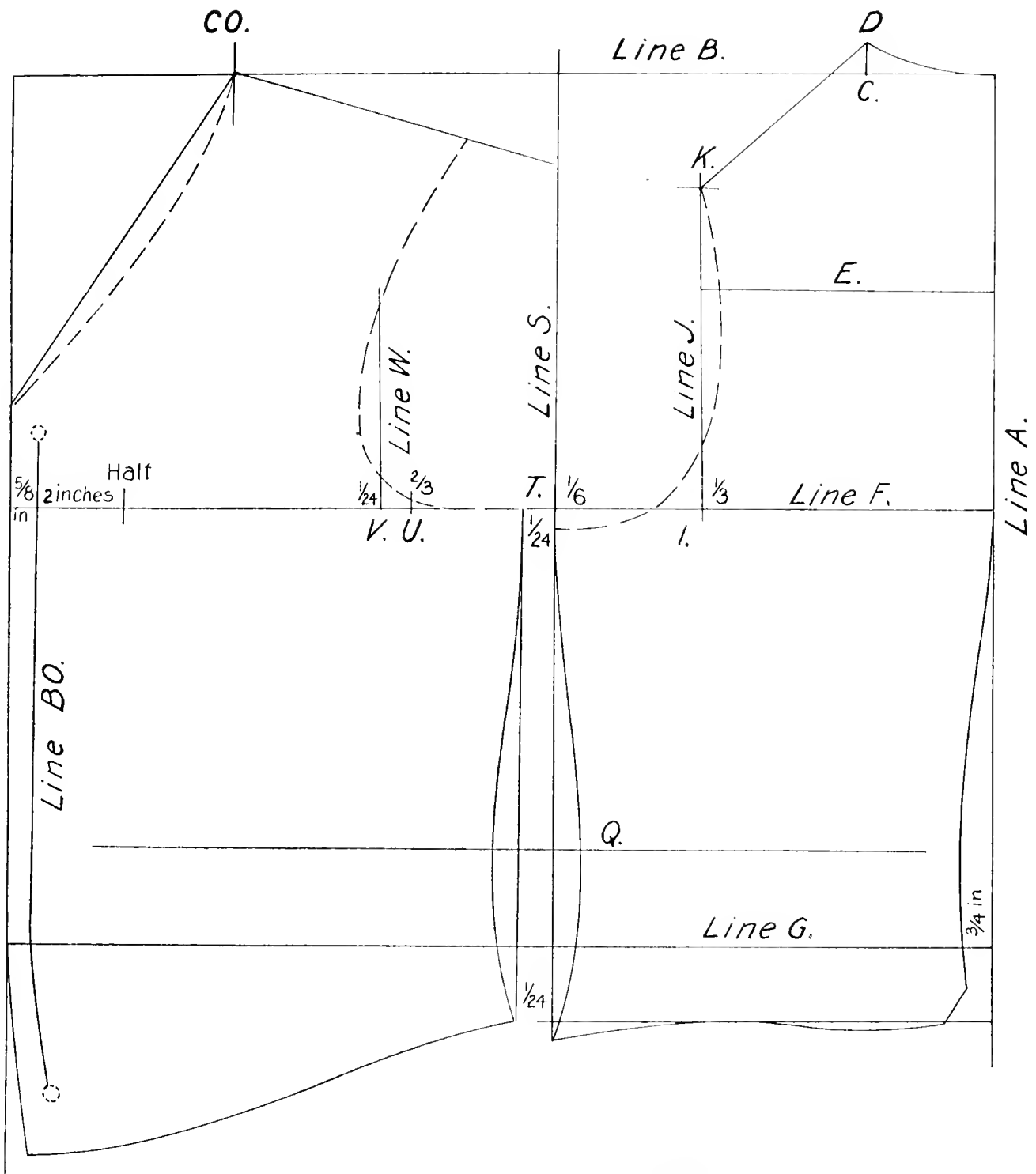

VEST—RULE DRAFT—PROPORTION OR MEASURE.

VEST DIAGRAM—TO TAKE AND APPLY MEASURES.

FIRST, from center of back of neck to top of front opening; second, to full length distance of front; third, to the side at point of hip-bone. The above are all to be taken from the back of neck. Fourth, straight around and over the breast at largest point; fifth, around the waist, allowing for space to button. To apply the above: First take the distance of back width at top from center to D, carrying that distance to CO, to front top opening to full length distance, allowing for all seams required in making up. The breast and waist measures are established by rules and systems given.

It is well in taking waist measure for the vest (when no trousers measure is taken) to take one under the vest as well as over, as there will be a difference of from one and one-half to two inches, which will be required as the amount to go over the trousers waist, and is always regulated by the weight of the material. A correct measure, if taken in corresponding places, will work in proof of the above.

The Double-Breasted vest is the same measure in the opening as that of the single, crossing at the same point of measure. All other distances are governed the same as in the Double-Breasted Coat, as to any width of spread wished.

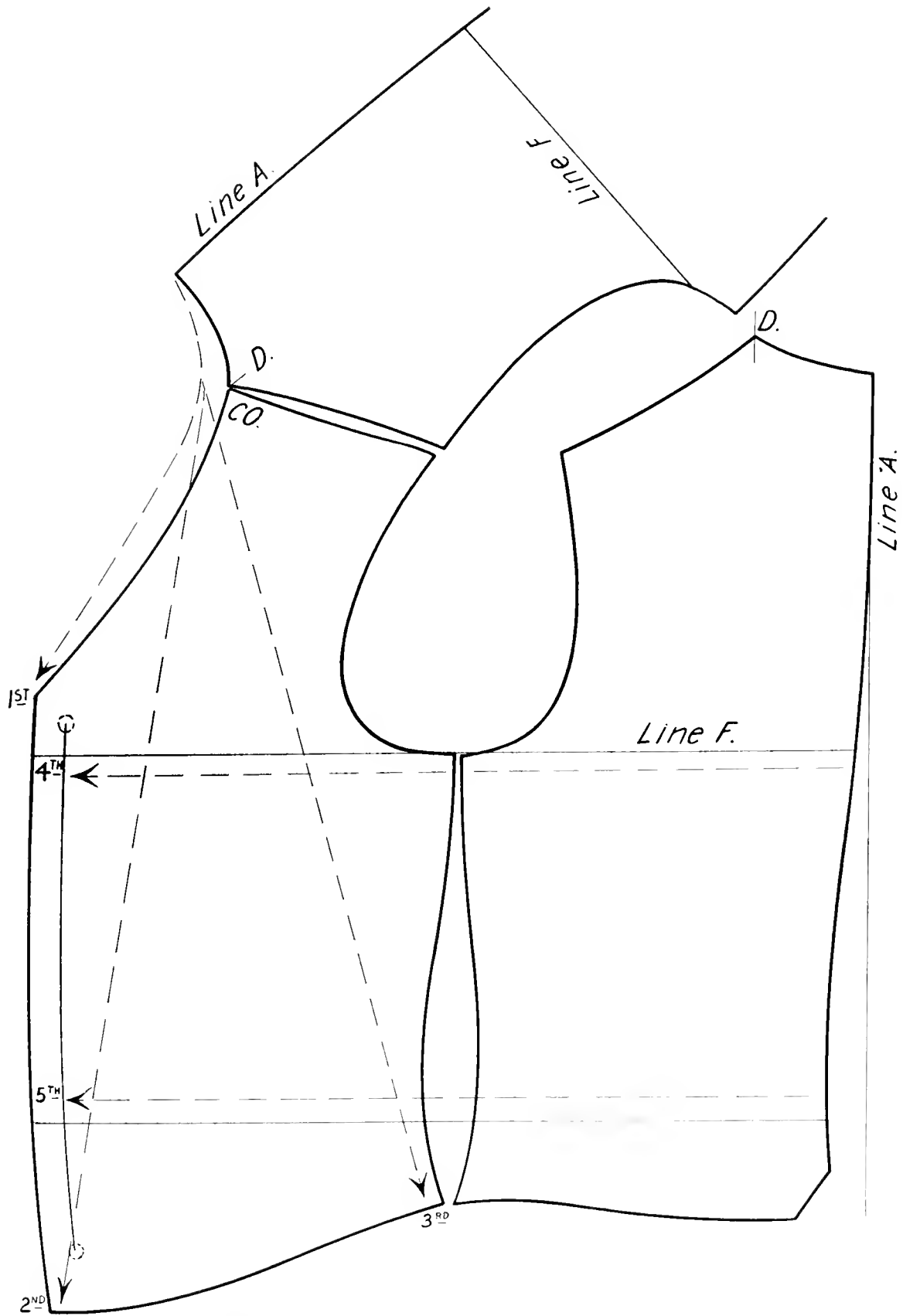

VEST DIAGRAM—TO TAKE AND APPLY MEASURES.

THE DIVISION SCALES.

THE scales given will be found useful in many ways, other than as for testing, and can be used for drafting minute drafts and as well used in practicing the different rules when away from the conveniences of large drafting tables and other requisites for regular-size drafting.

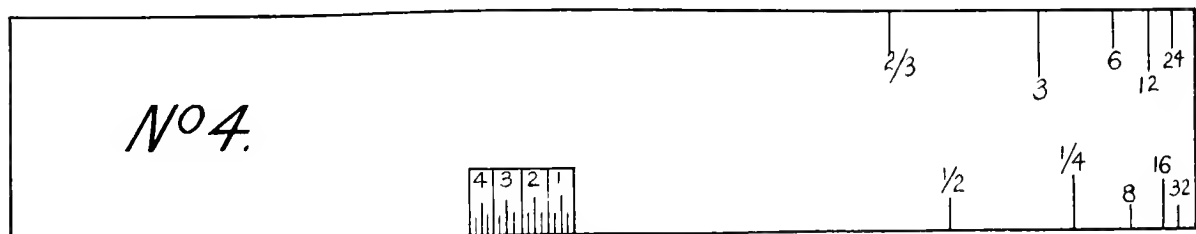
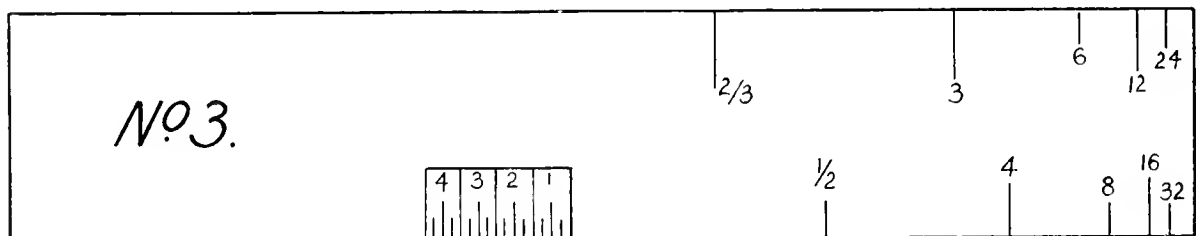
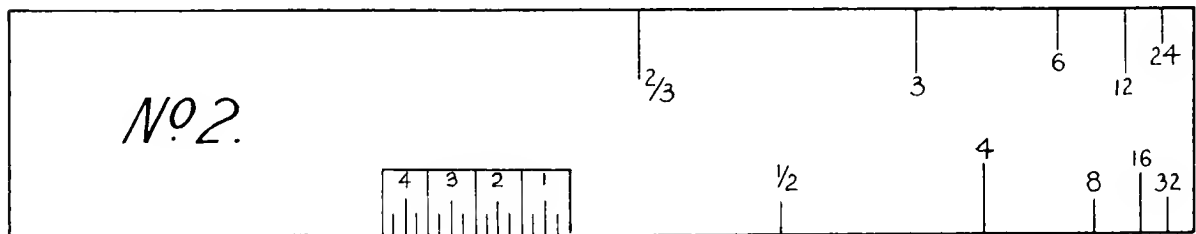
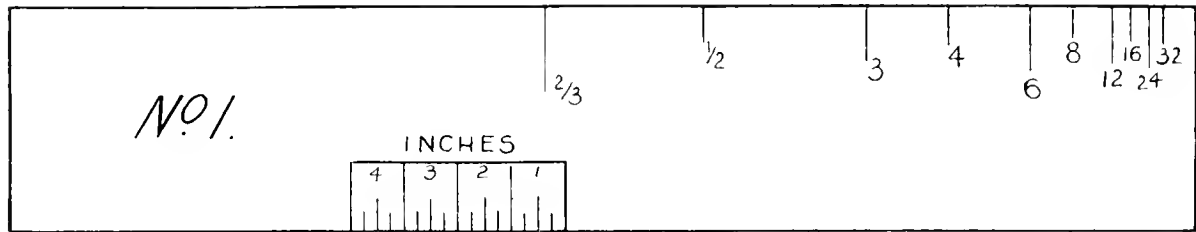

SCALES.

REMARKS

REMARKS—CAUSE AND EFFECTS.

THERE is probably no one branch of industry that has more perplexing and annoying problems to solve and that requires more patience and perseverance than the tailoring business in its several branches. Complications are arising all the time that require the best combination of many in one to solve, and for this reason it will not harm one to have many works treating on garment cutting, and there is no other industry that is confined to one or two, and a number cannot hold all there is to be known in the tailoring business; there is no other branch of industry using and adhering to the old rules, systems, or even theories of the past; all are seeking the most advanced ideas to keep abreast with competition and to keep in touch with the young by action, if not in years. It is for the lack of the above, in many cases, that the young influence of the present day is required in a declining business.

The most essential point in garment producing is the front shoulder point; next the hanging of a garment at top shoulder bone and also the blades. The first is the most important for the reason that it governs more rulings than any other one point, and unless it is properly located it will be impossible to make a clean and perfect shoulder.

The strap, spring or drapery and blade. If the strap distance of front shoulder at CO appears too long or full, do not take in the amount for correction until you first find the cause. First, see if armpit is too high or low, and if too high, leave it as it is and open shoulder seam at top shoulder bone and let it drop and the front point will adhere closely to the neck at CO. If the armpit is too low, then take fullness in, re-forming neck gorge to that amount. The collar will, if too tight, often cause the same fullness, and as well influence the spring of a garment.

It is well to remark here, as being very important, that in no branch of this work is a short collar in any way admissible, and is one of the most harmful of all mechanisms that can be made. The short and tight collar is for the crooked shoulder only, that is stretched to a place that it will not stay, and the effect of trying to hold up to place makes a more biased front edge and side seam of forepart requiring more spring, while with the rules and system given in this book, will, without a collar, stand up to place intended, showing that there is nothing for the collar to assist in doing, simply to be placed on the stand line, plain and easy; will even allow of one-quarter inch fullness as better than one-quarter inch short or tight on. A shoulder not pinned down too tight on any garment gives a more graceful effect, and consequently much care should be taken to see that it has ease on the top shoulder where the coat hangs from, as no coat can be well balanced without it. All who have had experience know that with all care taken in measurements the blade will work a fullness; but this is not objectionable, as a certain amount is required for allowing a forward movement of the arm, but a baggy appearance is objectionable and may arise from different causes. If caused by a too shallow sleeve-head allowing the outside or back of sleeve seam to drag down the shoulder to form fullness, correct the sleeve; if the blade, it is best to correct the blade by pinching-in the amount at blade seams and shaping to a distance required to take it out, rather than to cramp top shoulder by lifting it up. For the cause of this fullness and the taking out of blade each side a half-inch or more, a half-inch each side would, if corrected on the pattern to be retained, make it of one size less than what the breast measure taken calls for, showing the uncertainty of being governed by measures only, as good judgment is as well required. Different fabrics require different working, and, as well, different forms. All journeymen do not work as well on one garment as on another, or on one fabric

as well as on another, and for this reason it is as well, when so situated, if one can, as much as possible, place work in the hands of those who work separately the best.

The width of back as across from back notch for sleeve has much to do in a good garment; it allows front of arm scye to remain in place with ease (the point CO as well) and you can produce a better and more effective blade with it, while a narrow one will not allow any sleeve to hang well or any freedom of arm movement. This may be the case where a draft for a sleeve to arm scye would be effective by placing in it that part of the back taken from it; a too wide back is of small expense to bushel; a too narrow one is of large expense; in many cases, too, even with a new back and outlets, the effect cannot be corrected without a new collar, and a change at CO as a result. A small arm scye and wide back will make the most comfortable as well a better effect in a garment.

In making any changes for correction in a garment it is always best to observe first as to their influence and effect at other than their individual points, as often there are different corrections and that will benefit better the correction, and, as well, be less liable to displace others, as in correction of a side seam of blade in a body frock for too much fullness, it may be caused by front shoulder point CO, as too short of strap, by too long depth of scye, by the too tight or too short collar, as all or any one of the above would have an influence at full length of waist at CO to cause it, and the study of each and every one should be to thoroughly investigate and find out the most prominent one and remedy that; but first of all try by pinching-up of the under arm forepart and side body seam at center line S, to see if that will not make the correction without disturbing any of the other points, and if so, it will be much better than to take from side body at blade the amount as making too narrow for a well-defined artistic line. Often a little clearing of front scye at line W will let it go to place.

As the mechanism has largely to do with good results, the nearer points as connecting are drafted to place, and shaping to shape, it would be reasonable to expect the better results from it. The uncertainty of stretching and shrinking often misplaces itself, and if not held to the purpose for which it was intended, the result would be better without it. As the stretching of front scye at point of front shoulder bone for ease, letting the amount of it fall over the back with a flat and tight place, effecting just the opposite of intentions and making worse by it, as it takes from the fabric's elasticity, the purpose as intended for ease at that point is harmed unless held and worked forward to the place intended. It would be better without the stretching if poorly manipulated, as a shoulder, being the most sightly and attractive part of the garment, requires much care and study in producing. A good clean effective shoulder will often pass a garment with other defects.

The overcoat only differs from the under coat in all the separate styles in the advancement of front, and that, in all cases, is an open question, governed by effect as required, and of the different fabrics in use. As a rule, for a single-breasted, it will require from two and one-quarter to two and one-half inches advance from button-stand line BO, established in the under garment, and for the double breast, from four to four and one-half inches from BO. The surtout or any waist frock is only an enlargement of the under coat and requires a wider lapel.

In measure drafting all of the same governings are to be observed as in Drafts A and B, with the exception of those that measures taken govern to locate. The same will apply throughout this work and entire system in each and every draft in all their separate branches. There is no better way to determine the long neck form than by the use of proportion, and as well the short, though better the long. The location of the long neck form requirements as to locating the same by shoulder measures, taken over the round form, and so applied on a flat draft on paper, is classed as theory. That is not used by the advanced cutter of to-day for the reason that it has no evidence of proof whatever, but is merely an

excuse for errors, and theoretically is found to be wrong. Measures, if well taken and as well applied, govern all changes better than the long neck form, and this form is probably the most difficult, if not the worst, a cutter has to contend with, as the sloping shoulder follows the long neck; thus the first and third as given come in to assist one in solving a problem. To produce by all the three has given satisfactory results for a try-on, and more sure without it than any one given rule. The impression formed of the requirements of sleeve head for a high or low shoulder and the drafting separately for each of the same is in the class of theory and is so applied. If any require a change in a good sleeve head draft or a set pattern from it, it is the slouching form, who, for the cause of sinking into his armpit for self-support, will naturally drag down a sleeve head; but even for that reason it does not require a change of the head and only a sinking of the under arm part. This mentioned form is the only one I deem right to sink below the breast-constructed line F in any garment, and then attention first should be given to front location point CO for a remedy, as by letting that have more length it will let fall the armpit seye and avoid tightness of seye. The high and low shoulder are of one depth so far as the distance from top of shoulder to the bottom of armpit. The mere carrying of shoulder either high or low will not affect the sleeve; the distance in each being the same, the measures taken of back arm seye depth, strap and over shoulder will determine for each. As the shoulders of each may measure the same in the two forms, the depth of seye in back and the strap measure in front will differ from that of being the same in both shoulders. If the sloping shoulder is to be made up to the appearance of the high one, the sinking of under part of sleeve will allow of the carrying up of the sleeve with better result than the change of sleeve head.

SYSTEM
OF
PATTERN ILLUSTRATING COATS



LONG NECK FORM.

THE long neck form often requires more advancement in front from Z; in any case go forward a distance sufficient to form a good space to show from collar notch AO to the crease roll in order not to bring the collar step too high on neck, showing a short collar and a too narrow space. The long or short neck will take the same width of shoulder in most all cases. The difference of form is shown that if the long neck increases at CO it decreases at end of shoulder. The short decreases at CO and increases at end of shoulder. The short neck form is often actually wider than the long. The formation of collar for the different formations of neck forms is governed greatly by the prevailing style, as a narrow fold cannot take the high stand that the long neck requires. The amount reduced from stand for reason of narrow collar fold must be placed in addition to top of back of neck and advanced the same at CO. The reverse will apply to the short. The straightening of the neck gorge shape from CO to AO will answer in all cases for the falling away from the neck at that space with the exception of cases where a long neck is of a stooping form, but it will require the combination of the stooping to work with it. The neck gorge being formed first (a standard collar is well to use), observing in all cases the changing of it to conform to that of the neck. As the usual following of the long neck is that of the small (unless full-chested), it will require no change at AO and Z. If a garment when finished is too low in the neck, the correction is made by raising all around. This should be conclusive proof of the above changes.

The illustrative diagram 1 shows first how to produce for the long neck; second, the collar; third, the lapel from AO to Z; fourth, the straightening of gorge from CO to AO, and collar as changed from standard. It is as well to use one standard collar for all, and make the necessary changes as to neck requirements, rather than to produce one for each and every draft. The dressing of the neck in most all cases and the width of style for collar fold regulates the amount of stand. It is best shown in taking measure for depth of scye in back to call first that amount (as three-fourths, one, or one-and-a-quarter inch) before calling depth of scye measure, and that should be from whatever point the stand is to be located. If the style for narrow fold (the neck being long and of high dress), that amount would go on collar stand if wide fold, and must be added at top of back, and as well forward from CO to AO. As the long neck inclines up it requires that same incline in draft as taking more even than the strap measure taken. Usually it is taken lower down than when applied to a draft, and if too short to permit of going up to place naturally will seek the level and fall from neck, extending over on shoulder and losing the effect intended.

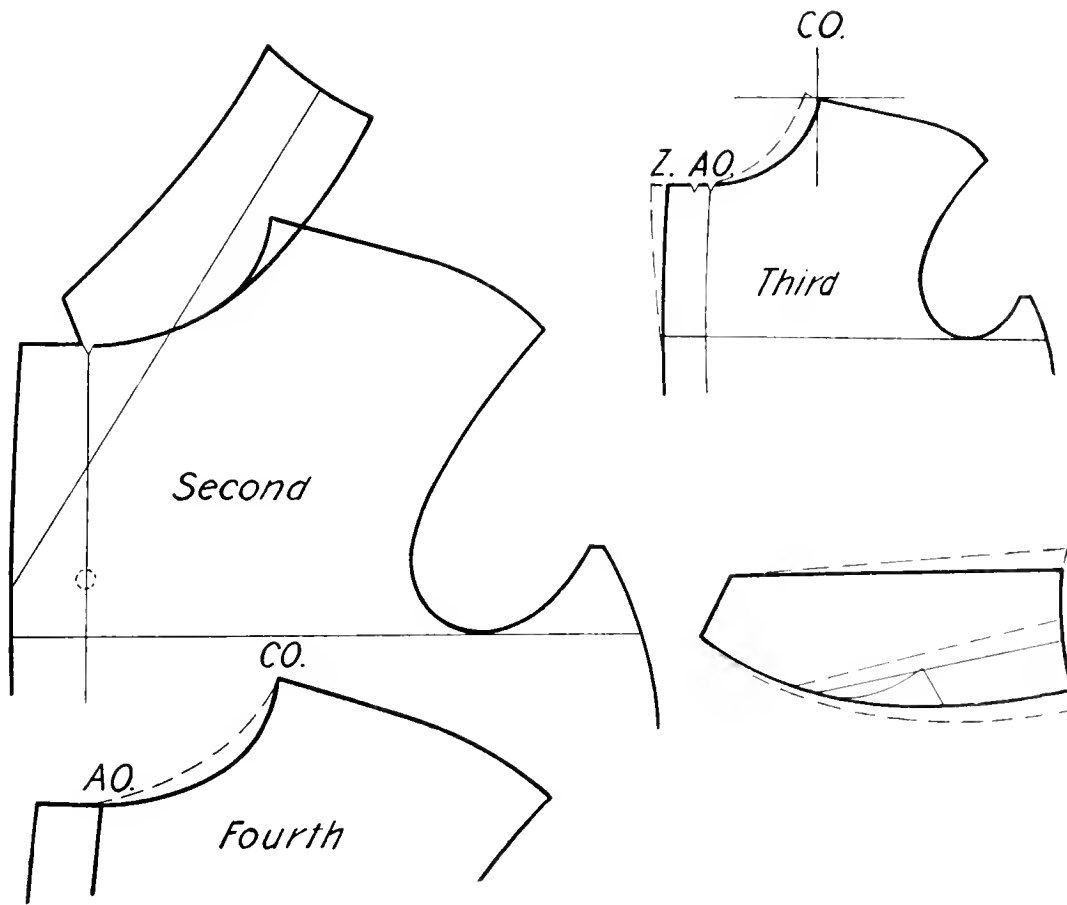
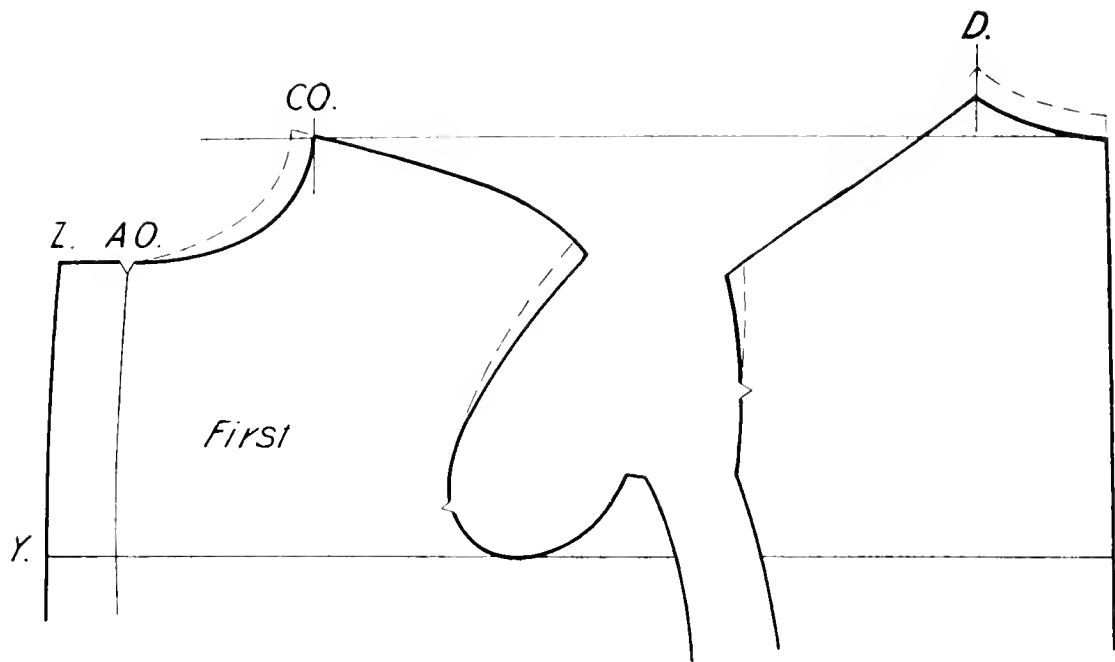

LONG NECK FORM.

SHORT NECK FORM.

THE short neck is in all practical workings the opposite of the long. While the sloping shoulder will follow in the case of the long, the opposite will be found in the short or high, and in each measures will determine, as will requirements of AO and Z to be located.

The cutting down of a too high collar after the garment is finished, if too high, ought to demonstrate the above illustration in practice and make the changes before, and in no case are they so strongly illustrated as by proportion ruling. As to further illustration: If a thirty-six breast calls for nine inch depth of scye back, in proportion and measures call for eight and one-half inches, it requires one-half inch down in back and one-half inch back from CO, otherwise by leaving CO standing it would carry the back that much further forward, and making still shorter as to points going to place in this work; the long neck would be just the opposite. The short neck usually follows the large, and in most cases will not require a change at AO and Z.

The illustrated diagram, first, showing the reduction; second, with collar; third, if change from AO to Z required, and the change from standard collar.

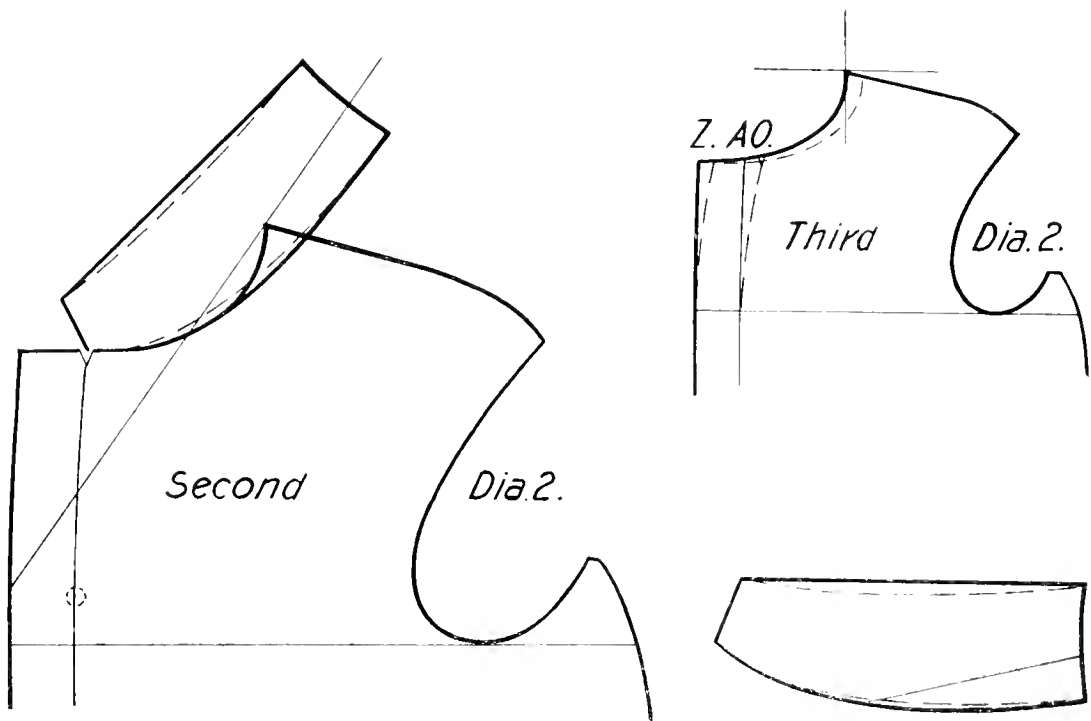
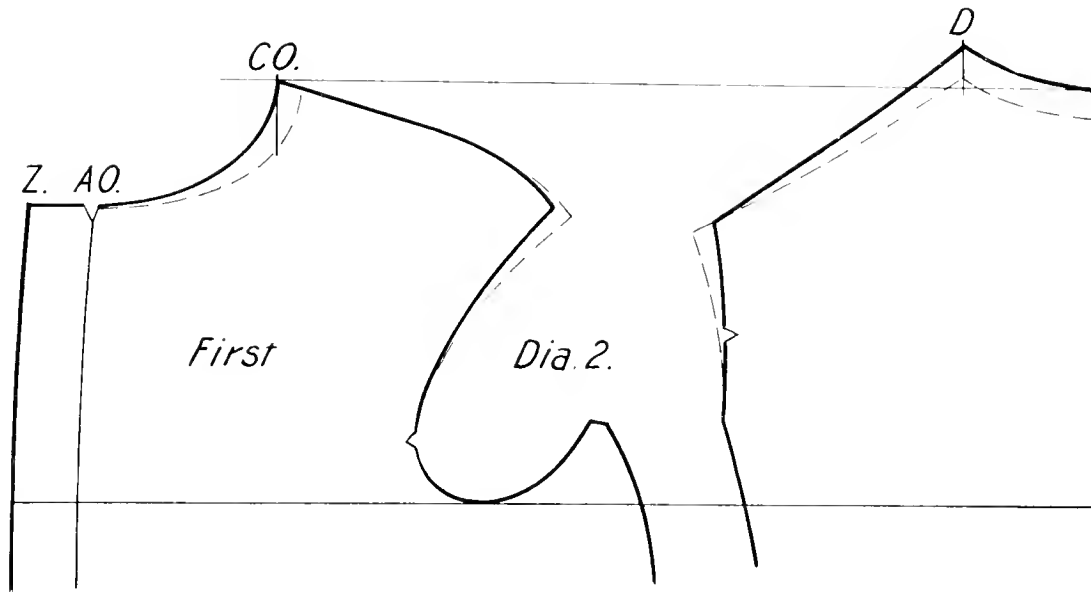

SHORT NECK FORM.

NECK GORGE.

THIS is governed by strap measure as to re-formation of either; the long and short are used and applied in all cases to locate CO either up or down, and from it will establish the depth of gorge.

The first represents the long strap measure, and the second represents the short strap measure.

This work never requires any cuts in the neck gorge, nor will it allow of a tight collar; it will allow of a collar one-fourth inch long and easy on rather than one-fourth inch short or tight. The effect of a cut is poor in two ways: first, if only a cut without anything out, reduces neck gorge from CO to AO one-half inch out of place; second, the throwing of more fullness to crease-roll where less is required. It will be found in the working of the neck gorge, as given in this work, that without a collar it will adhere close to the neck and the front stand to place without the aid of a collar, showing conclusively that if in any way with collar on it is wrong, either it is the collar's fault or the result of having too short a front strap distance. First try the collar, and if no relief by that, then the strap; often it will be found both, and either or both will throw fullness on blade for cause of pulling in at hip and tightening from back of neck at lines A and B to hip.

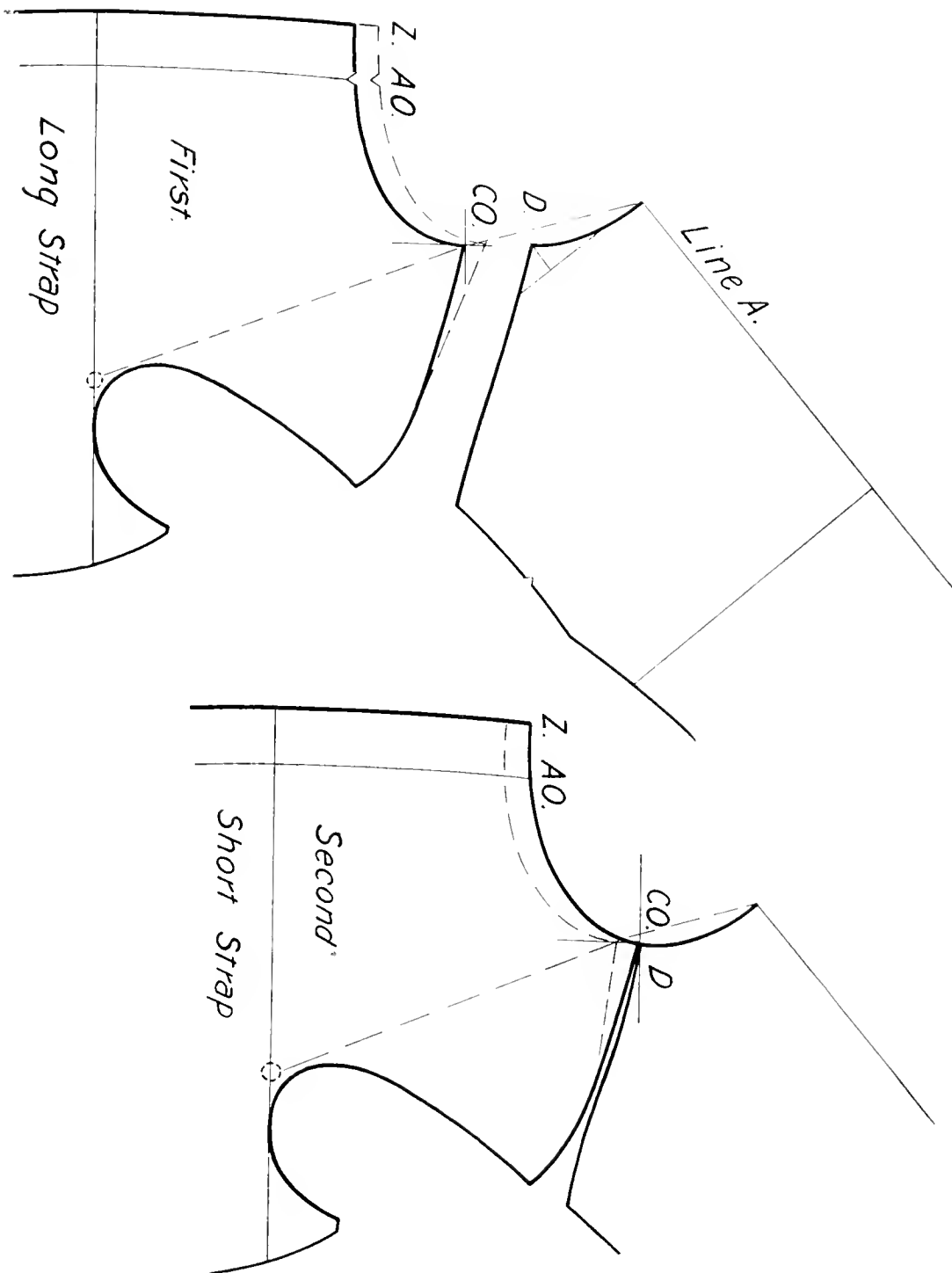

NECK GORGE.

ERECT FORM.

THE erect form will draw more distance from top of neck at back (lines A and B) to R at larger point of hip, requiring more space from line A to D and CO; while the length of strap measure will show this, it will not show the best place to place it. The best rule to follow in all such cases is that of taking cloth from where it is not wanted and place where it is; this will apply in all cases. The most natural way is to go from line A the distance required, and this (as in the stooping) is best determined by good judgment, and as a basis for starting three-eighths inch is a good average.

The over-erect form will require advancement in front of AO, Z, and line X, as will a shorter depth of back from line B to F. This can be worked in, either by advancing CO to take up the back or by letting CO, AO and Z remain, and sink back only down from line B to back center as formed by change from line A (in the second back). The whole back (for reason of no seam) must be applied as changes in back first and back second are illustrated. The blade illustration goes with the whole back (first). The end shoulder goes with the advance of CO.

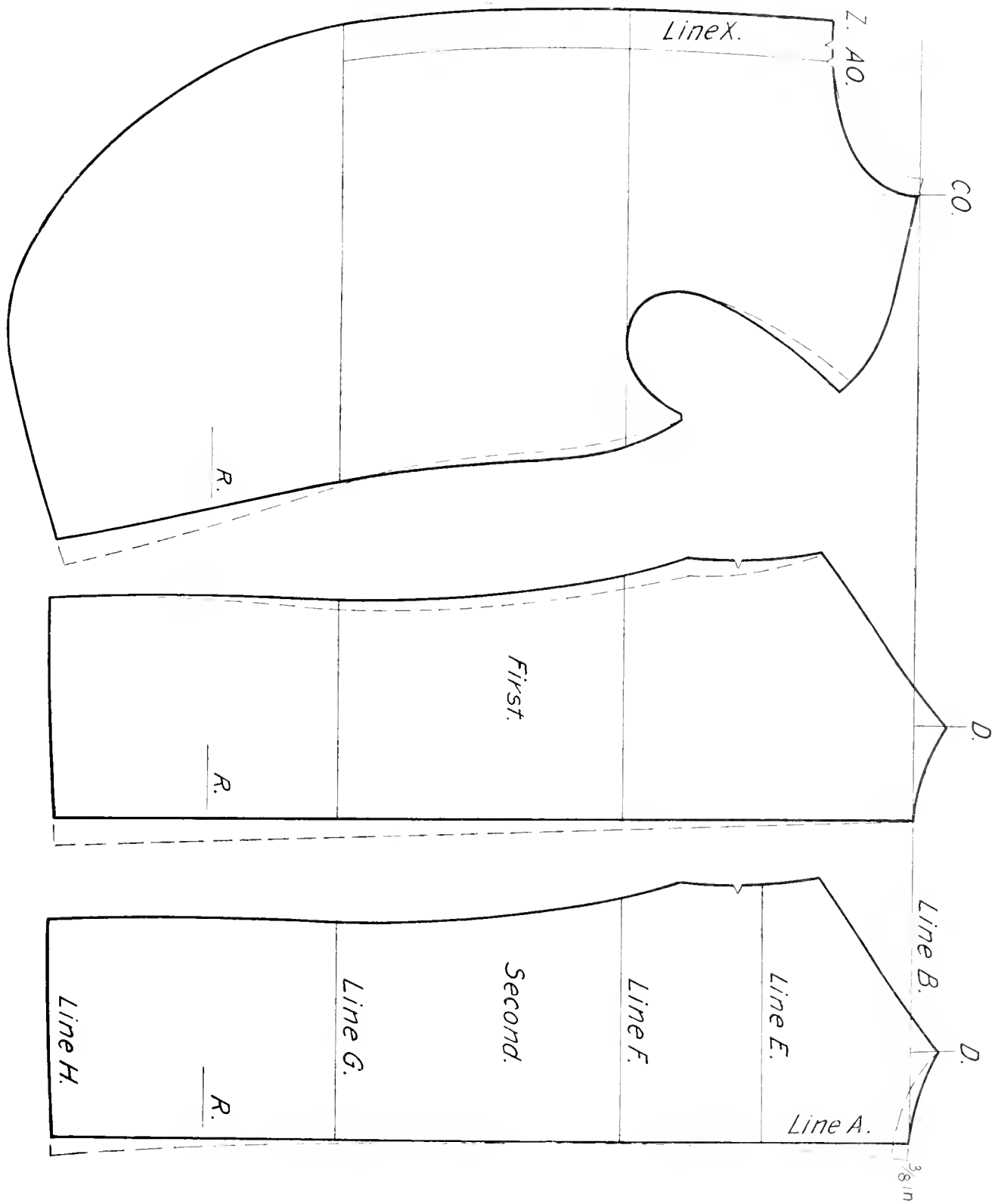

ERECT FORM.

STOOPING FORM.

THE stooping form is the opposite of the erect only of more extreme cases, and, like the erect, must be governed by good judgment. The three-eighths inch as a rule base for the average forms will suffice. The placement of the fabric as wanted is very strongly illustrated in this form. The second shows that, by holding the pattern first at line A to line F and pitching in from line A at top three-eighths inch, it will throw out at line H at a distance of thirty inches, three-fourths inch. The amount that throws out goes in from line A and re-forms back. Take the same amount from back line of forepart, and re-form from edge by it.

To hold this change effect, first mark back shoulder at top at K and to L. The shaping of the back as the second, will force or allow CO to drop down and forward to place.

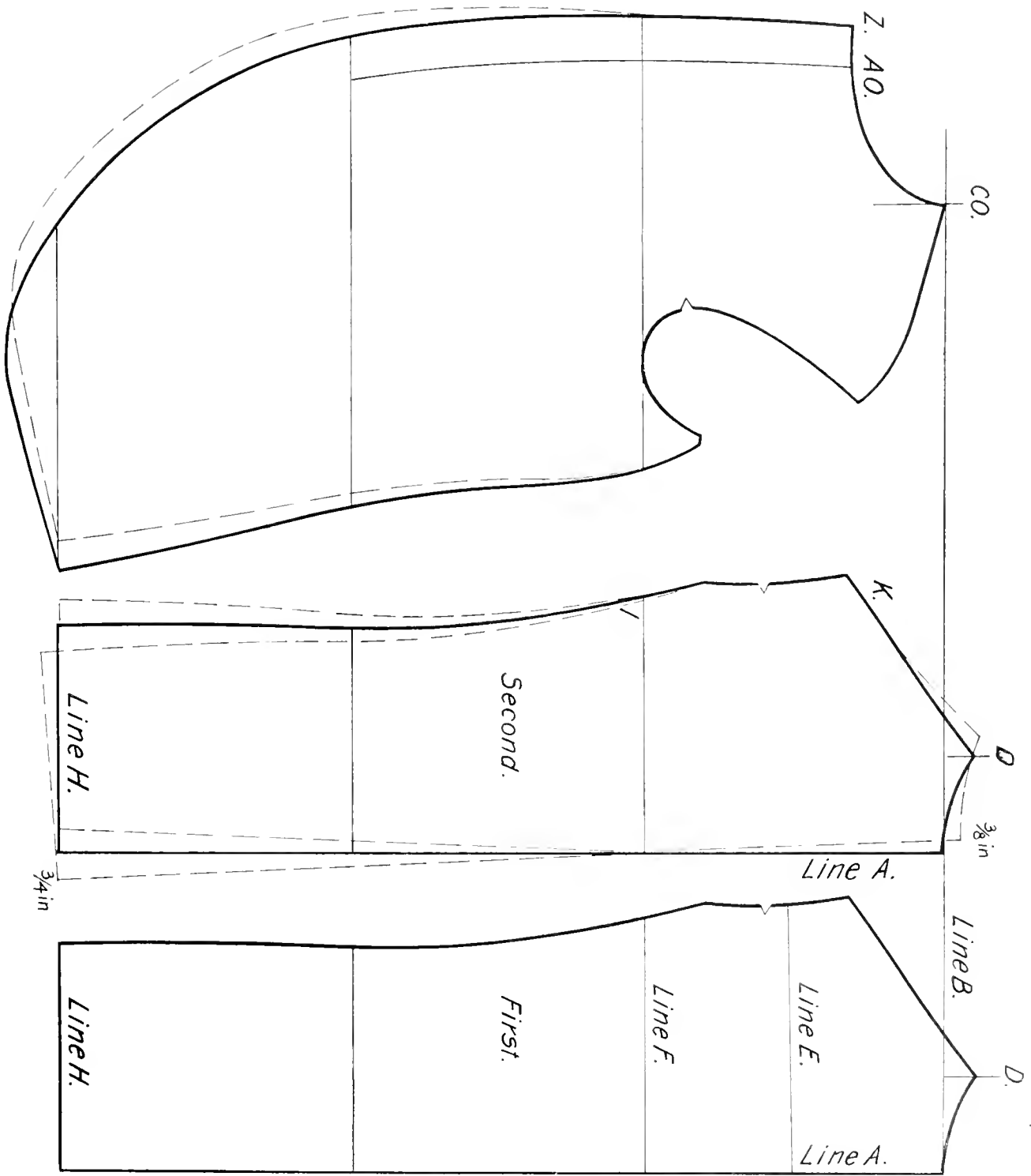

STOOPING FORM.

CORPULENT FORM—SACK.

THIS form is usually of the erect, though found in the stooping; in either case the advancement for it is the same on line Q from line X at front. In the first, for the amount of increase for a good shape line for a low roll, advance line F to Y and take the same amount from blade. For a short roll it does not matter; it can run to the breast line at Y, and even extend out from Z, if desired. The second is for the more erect form, and the above long, or short, roll, will follow in the same way.

In the adding to, or reducing from, top shoulder seams by that of proportion, either by drafting, by measure, or by alterations when trying on, care should be observed not to change all from the one, but an equal amount from each one will produce the more artistic line of seam. The higher the back seam can be carried up on to the shoulder in good proportion with the front, the higher will be the shoulder effect from back view, as a sloping back shoulder seam with any amount of make up will not give it the straight, square look; this should convince one of the importance of good artistic placement of seam lines, showing the influence of them on the eye as it follows them, in defining even a good impression as bad in effect. The mention of shoulder seams can be observed in all garments, and especially in those of the more dressy effects, and more on occasions when the back as well as the front are the center of surrounding criticisms that will not allow of the backing out for concealment.

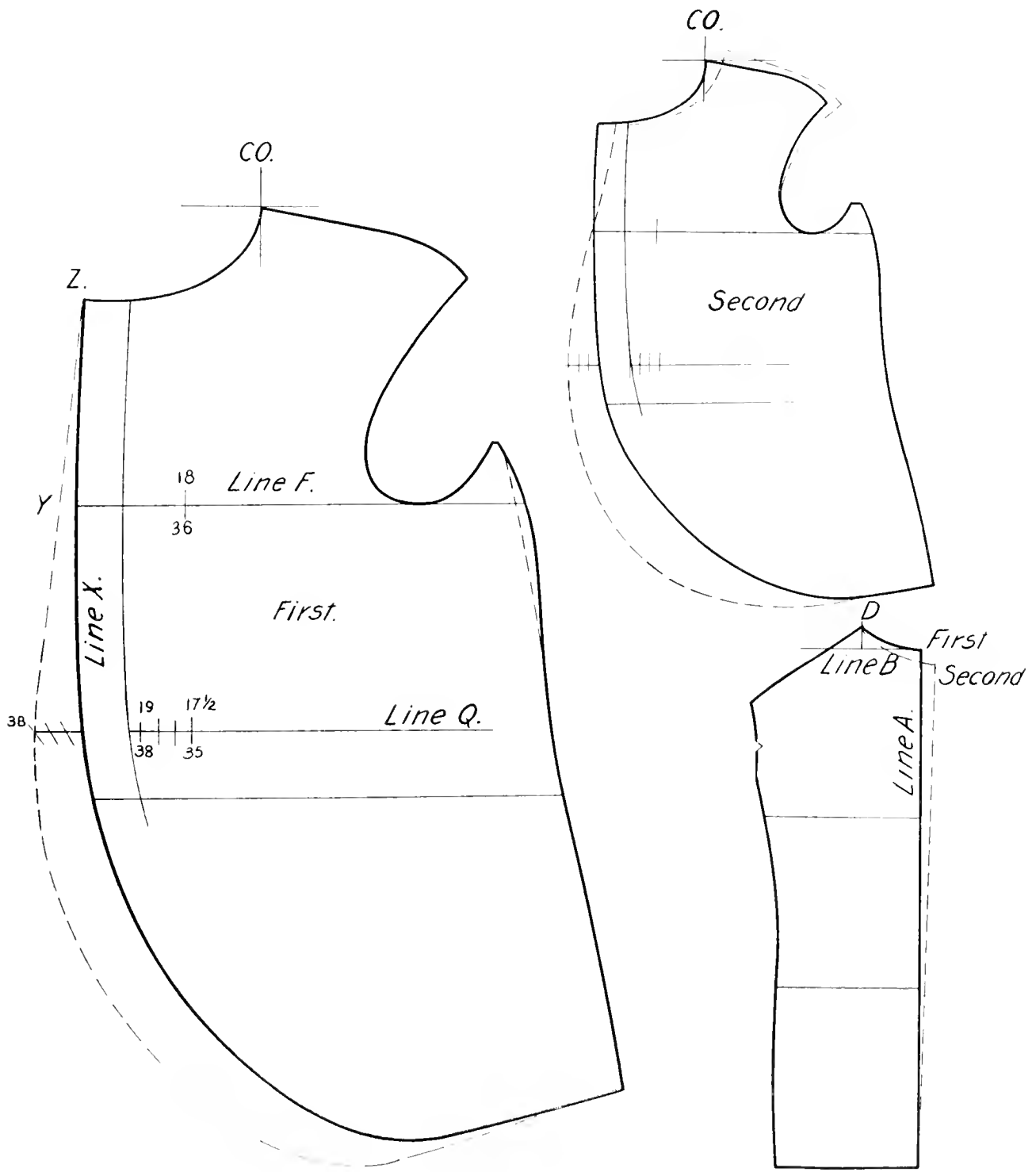

CORPUENT FORM—SACK.

CORPULENT FORM—FROCK CUTAWAY.

ALL explanation given in the sack coat will apply in every way to this, the first and second showing it as being the same.

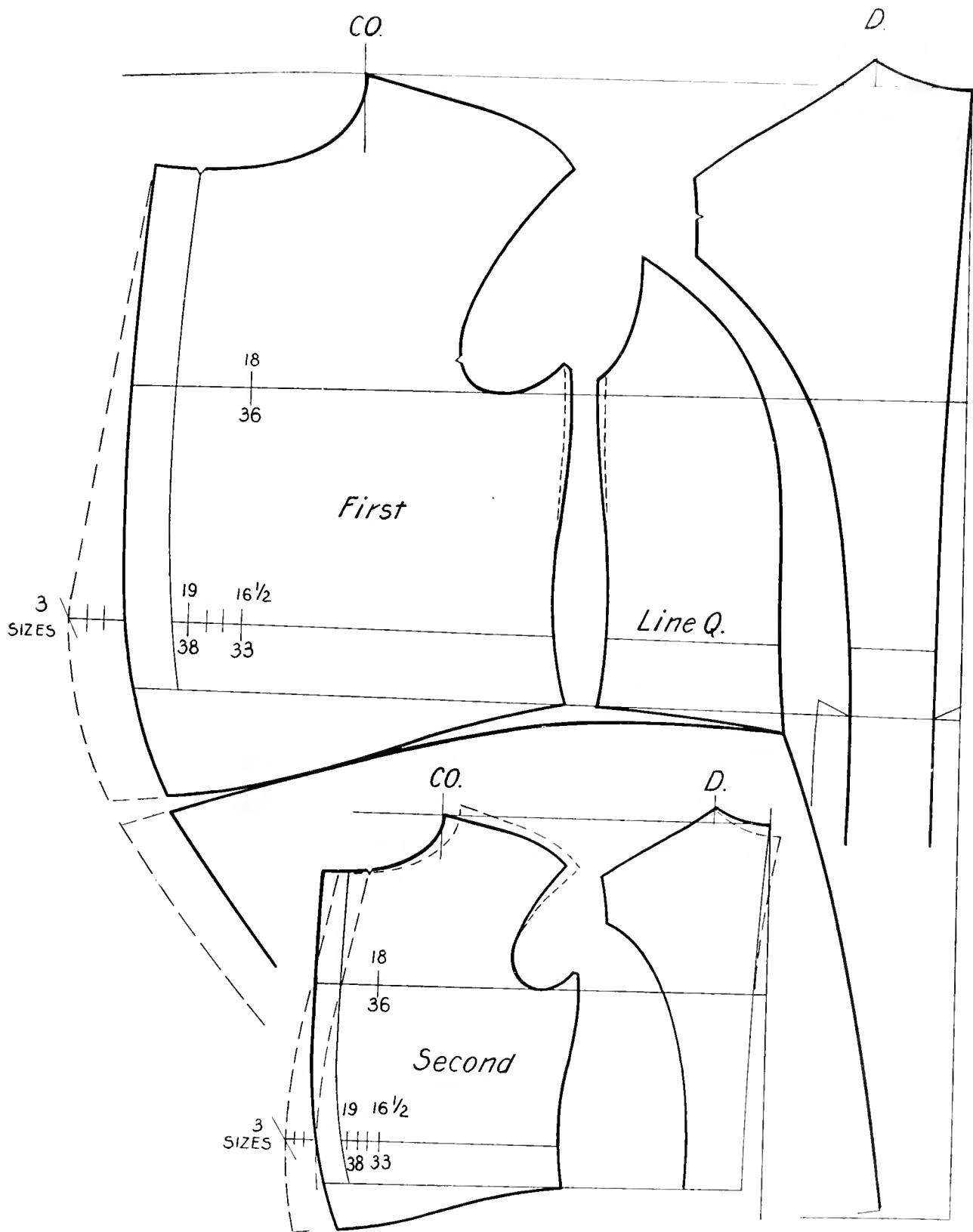

CORPUENT FORM—FROCK CUTAWAY.

CORPULENT FORM—D. B. FROCK.

THIS double-breasted frock shows how produced from frock cutaway. The changes for corpulency are observed the same as those previously given. The second showing change from AO, if to button with three or lower roll than four.

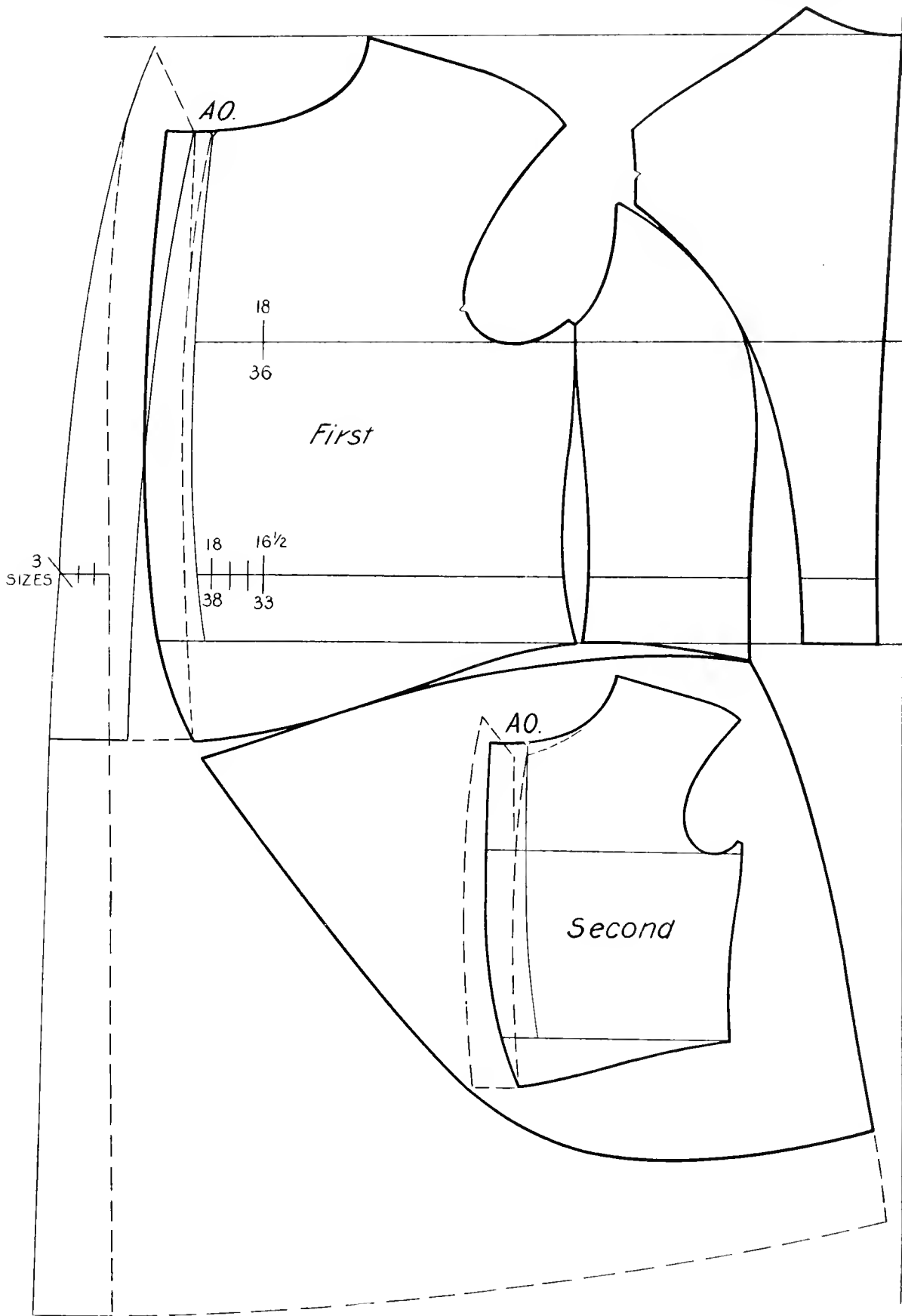

CORPULENT FORM—DOUBLE BREASTED FROCK.

CORPULENT FORM—DRESS COAT.

THE same changes govern in this coat for corpulent forms as in all the others, merely extending to whatever size required. This and all are based on three sizes larger waist than breast. In the dress coat, the back is often as prominent as the front, and for that reason as much attention must be given to it. A fine front and a baggy back from blade to waist is as bad as a poor front effect. Often in this garment the strap shortness and shortness of collar will cause all the tightening and shortening of the required distance from neck at back line A, front shoulder CO, and to back length at waist. As this garment requires a wide back across the shoulders and easy blade for frequent using of arms extended, it is well, in the correction, to give more length of strap distance. If not remedied by this, let out the side body at bottom of waist, and let the fullness fall to place on the blade in a graceful form. The shoulders being the most sightly, both front and back should have much care. Often there will be caused bad wrinkles, as drawing from CO to front of arm; this can be remedied in most cases by the advancement of CO and that amount taken from end-point of front shoulder. This will as well shorten and take extra fullness from back as back drops down, by carrying it forward with the advancement of CO forward. The different forms of illustration must always be observed as combination in all change. The mention of back shortening and shifting of shoulder will as well apply in any garment as so affected.

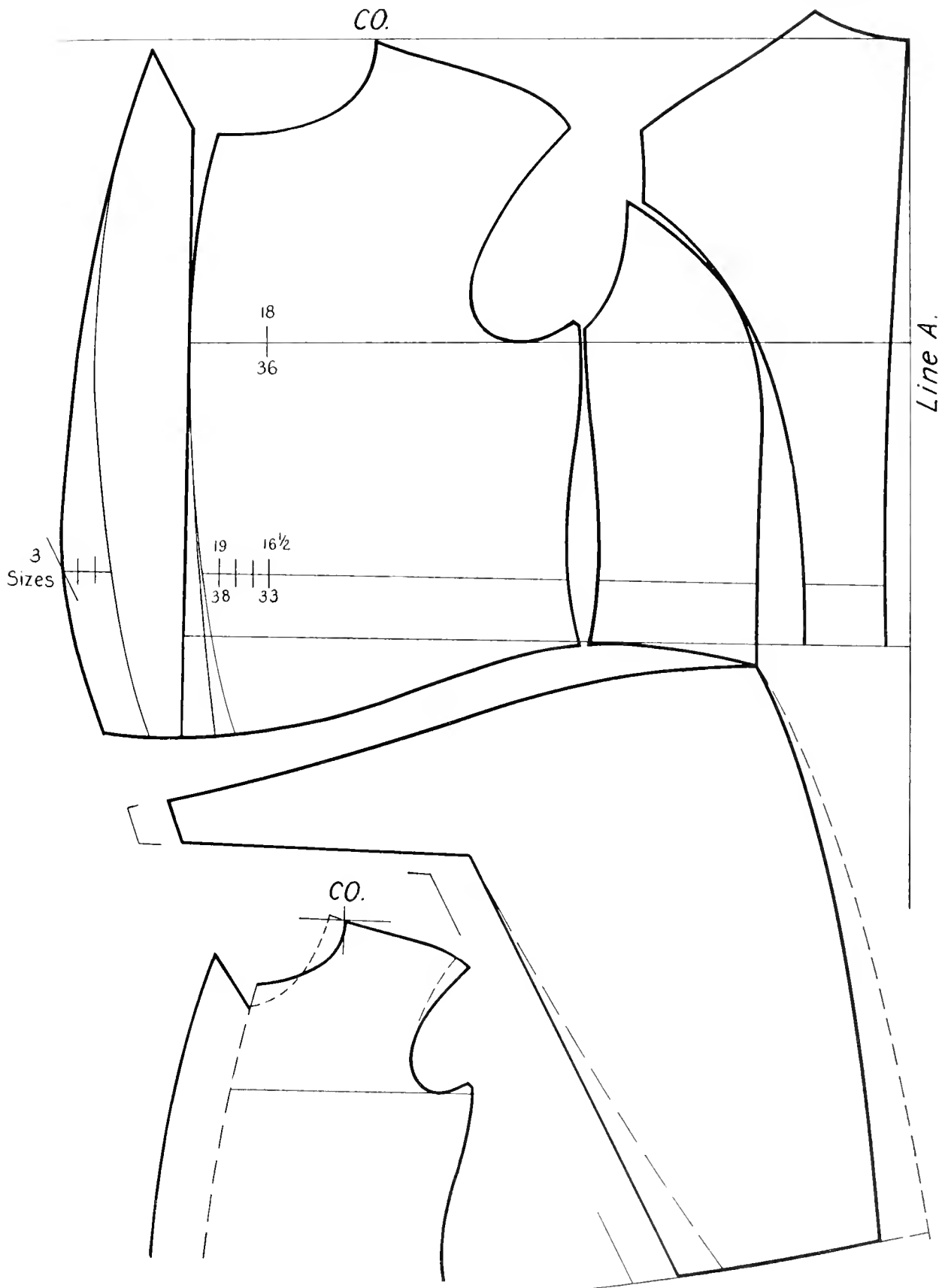

CORPULENT FORM—DRESS COAT.

DOUBLE-BREASTED UNDER SACK.

THE double-breasted under sack is only the extension of the under sack in the front, and that as to one's own opinion and as the fabric requires. A distance from line BO of three inches is a conservative amount. The first showing collar at stand, the second showing a peaked lapel, also the throwing down of collar at stand. The collar represents the forming from standard of any collar for a short roll that will stand in place, and not draw down from crease established as a permanent roll.

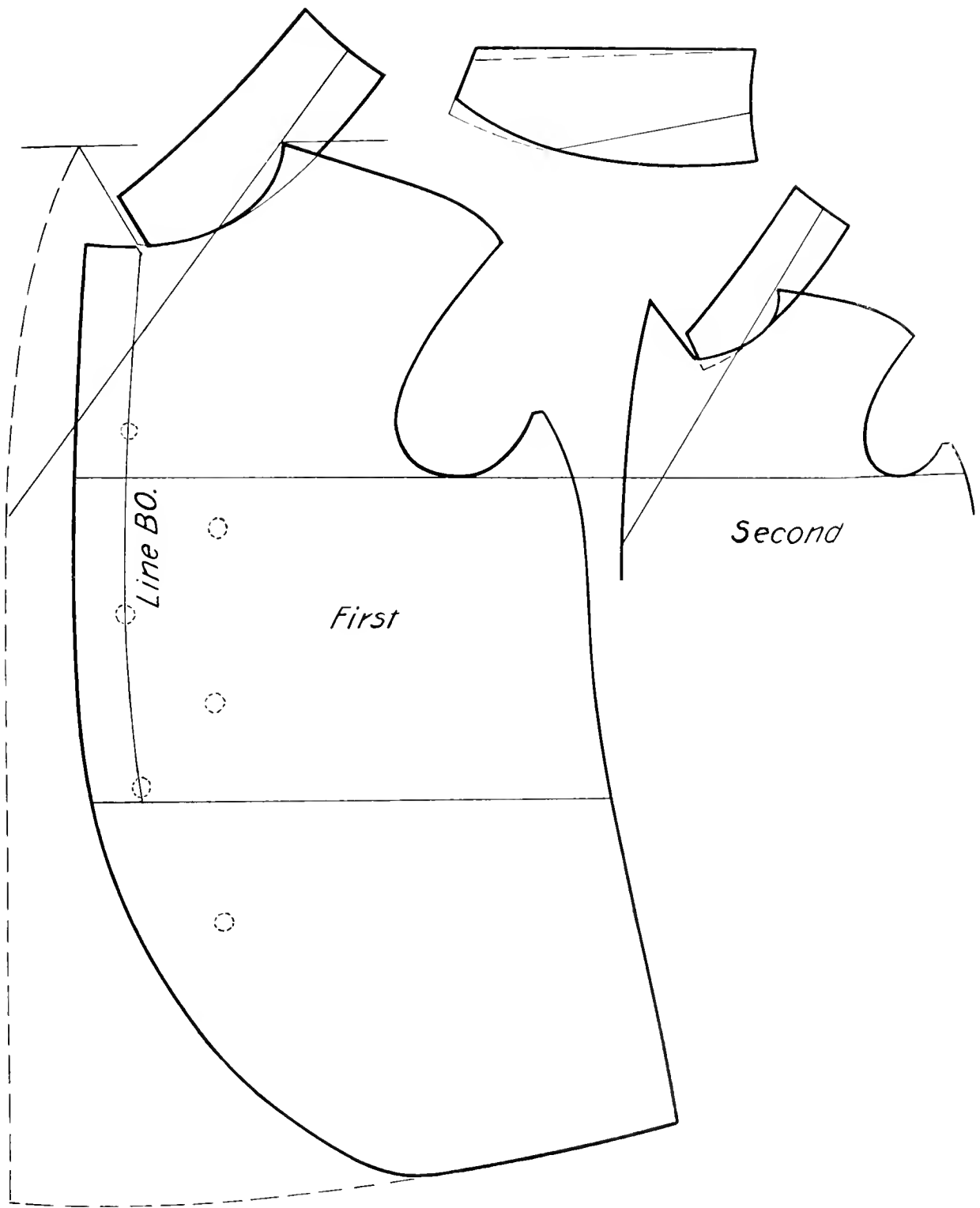

DOUBLE-BREASTED UNDER SACK.

DOUBLE-BREASTED OVER SACK.

THIS illustrates a production from the under sack with front extension and the carrying down from line H to distance required. For this front a good rule is from three and a half to four inches extension from line BO of the single-breast button stand.

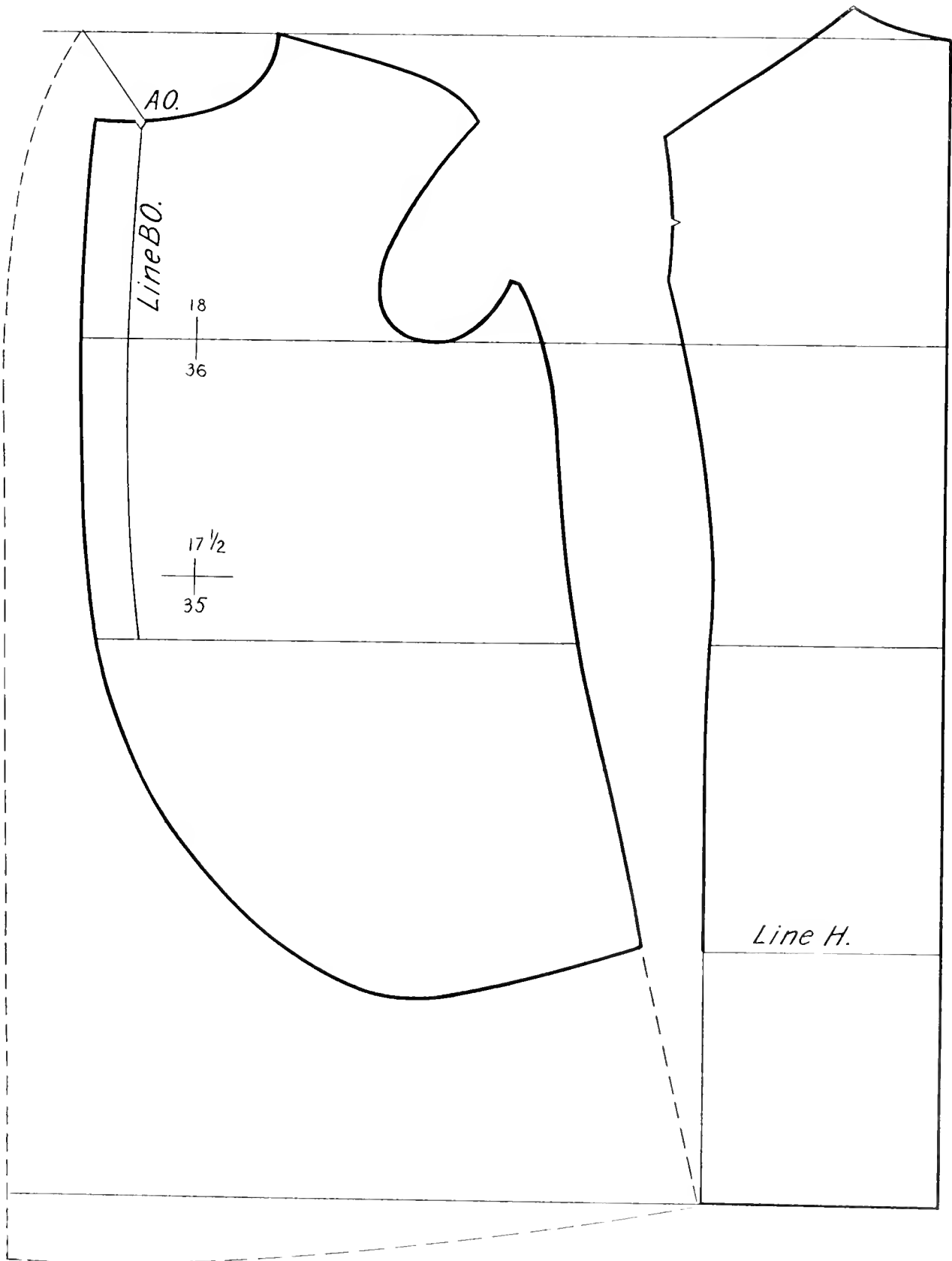

DOUBLE-BREASTED OVER SACK.

FLY FRONT OR CHESTERFIELD OVERCOAT.

THIS coat is only an extension of front from line BO of the single breast and is governed by the prevailing style and the material. A good rule is from two and one-fourth to two and one-half inches. It may be well to mention here that judgment must be used in all cases as to the fabric used, as some will waste in edge, some take up more than others in making up, and this will apply as well to all seams of those of like material.

A single-breasted overcoat to button through will not require quite as much front, and from one and three-fourths to two inches will be sufficient.

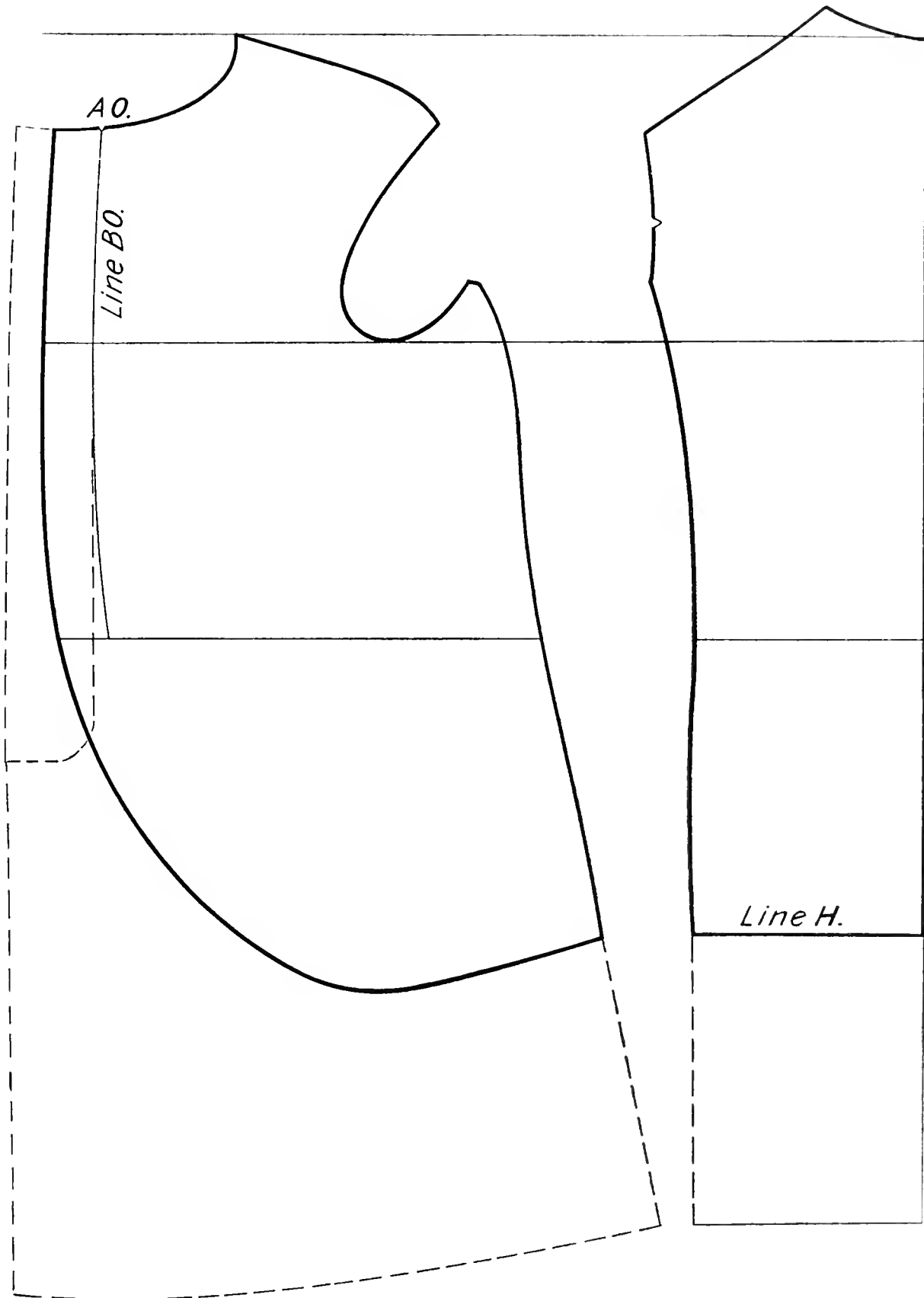

FLY FRONT OR CHESTERFIELD OVERCOAT.

DRAPERY--EFFECT.

IN placing the amount of drapery in any garment, as to requirements it will be necessary to keep in mind the changes and effects previously given as to the different forms, and observe well their effects in applying drapery, as the stooping form will require all in front, while with the erect the opposite is required. The first showing equal division of distribution, the second the erect, the third the stooping, the fourth any placement of side seams.

Much of the effect of this garment, and, it may be said, the principle ruling of any extra drapery given, is governed by the hanging of the garment on the shoulder as to the result wished for.

If a shoulder shows too full about the neck at CO, do not mark to take in that amount until first seeing if the shoulder does not pin down too close and ride at top shoulder bone. If so, (without disturbing the collar or sleeve), open up the top shoulder seams from CO and D to the end shoulder at sleeve seam, and by letting the coat fall so that it will rest easily on the shoulder bone, it will often be found that the fullness at neck CO will drop close to place, and the amount of ease over shoulder bone will give a much better hanging garment, as well as give more ease of scye.

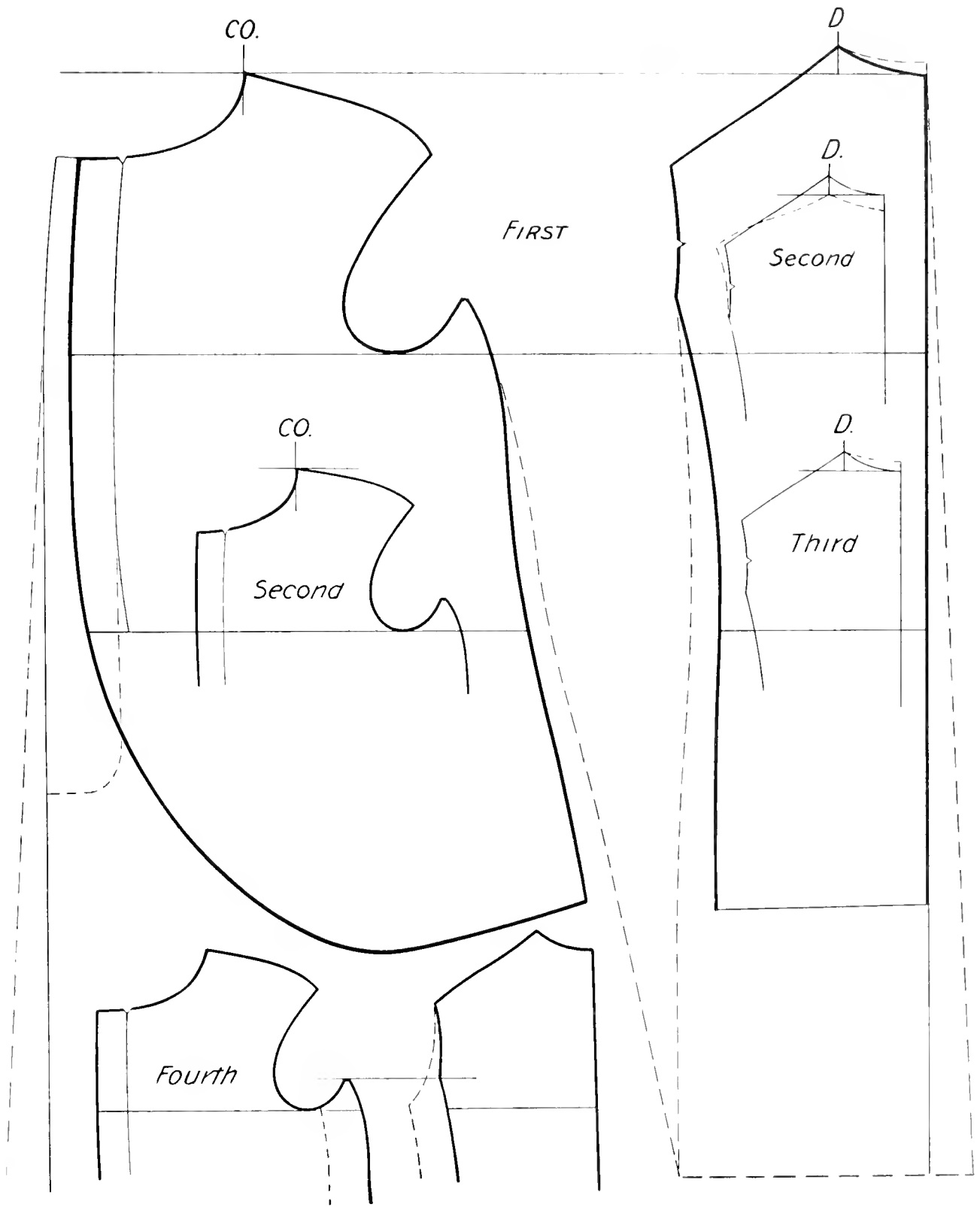

DRAPEY—EFFECT.

FRONT EDGE—TO TIGHTEN.

THIS will often work well in cases of ordinary stout forms. Drop from M three-eighths inch, and re-shape armpit of scye. When brought back to M and L, it will throw back extra spring and take that much from front. The amount the extra spring requires taken from front part at side seam, and that amount placed in the front, and the lengthening of side seam the three-eighths inch taken from it at M.

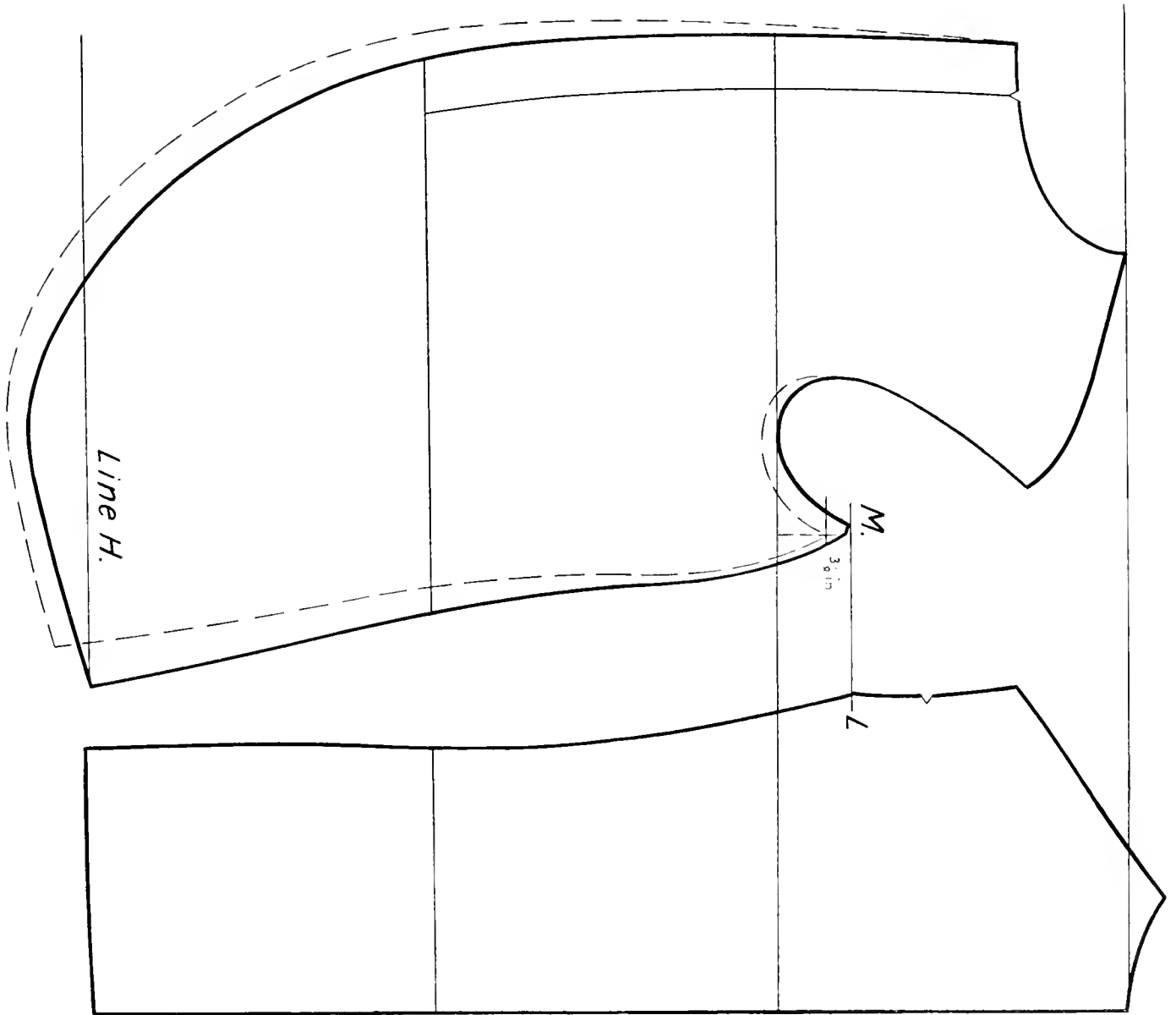

FRONT EDGE—EFFECT.

BLADE SEAM—TO PLACE.

THE purpose of this illustration is to explain that the blade at back scye seam can be placed at any space separating from the back that may be desired, either high or low. The taking out of more or less at the three-eighths inch should be regulated as too large or too small blade form, as the more taken out the more fullness will be given the round of blade as well, and allow of closing up the scye in back to conform more closely to the arm that this form (the first) develops.

The small or flat blade (the second) will not require as much opening at the three-eighths inch. The extending well forward of the top point of side body at the three-eighths inch will better form the back part of arm scye and not allow of as much extension below line G, as all seams going together are of one length. The same effect as to a straighter curved line for back line of blade can be produced as well in the round as in the flat, by producing the flat side body seam line first and taking the amount at the three-eighths inch from the back, narrowing it from the three eighths inch to K.

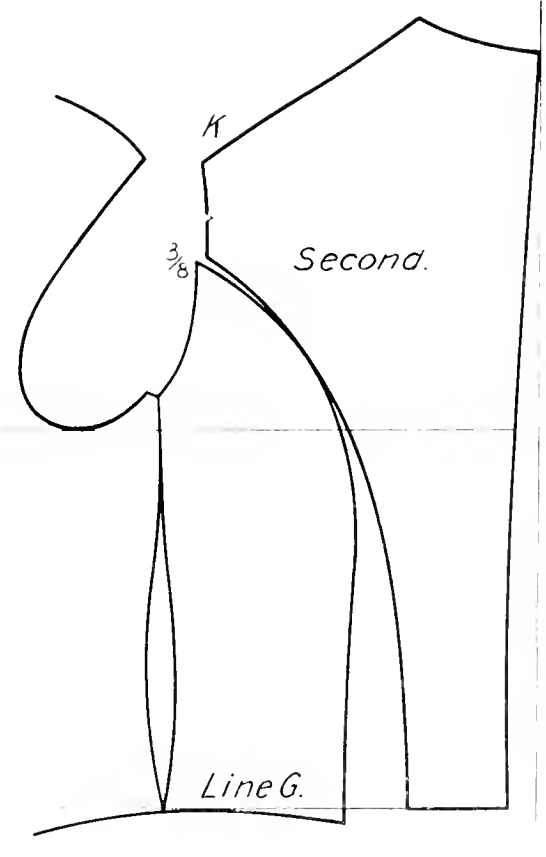
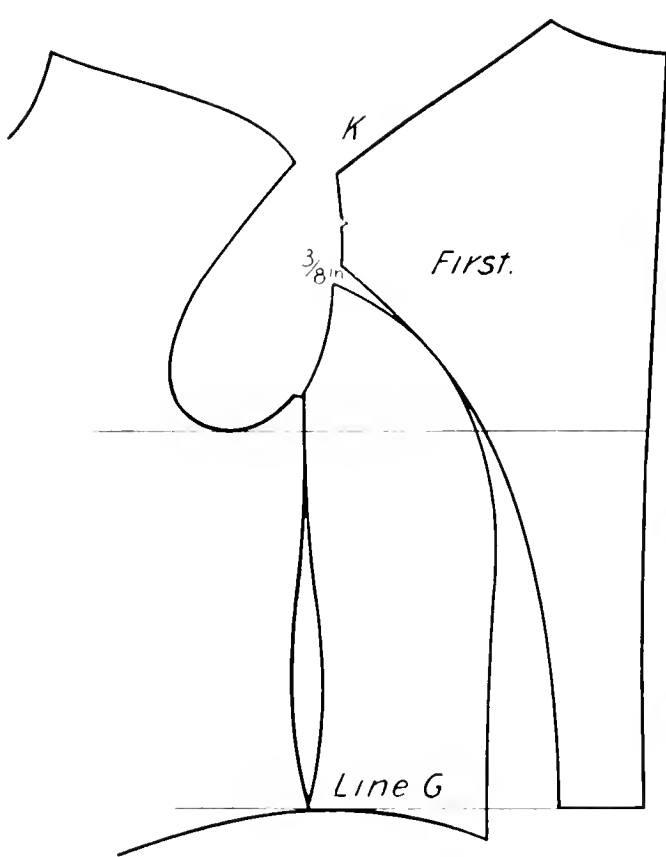
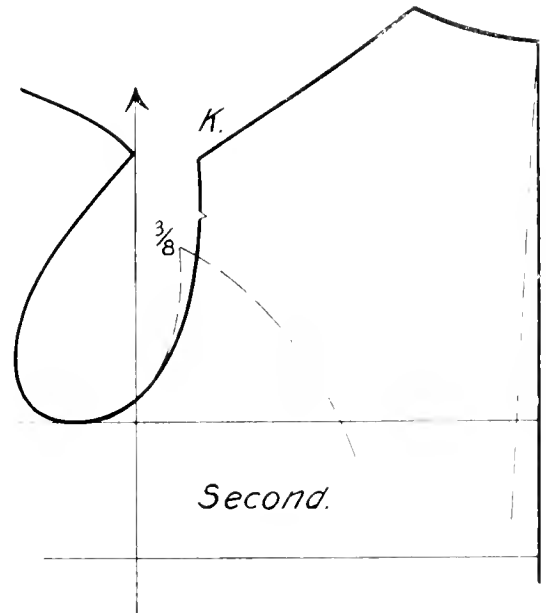
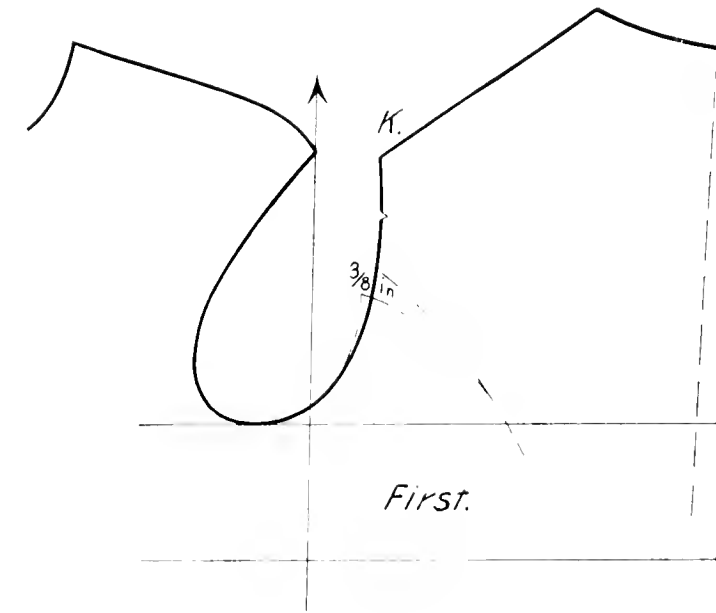

BLADE SEAM—TO PLACE.

TUXEDO—SHAWL ROLL.

THE artistic effect of this garment lies mostly in the formation of the front edge line, giving a well-shaped shawl collar and the continuance of shape of front from and below it; as it does not button it is at the will of the designer as to shape. In this, as well as in any coat rolling permanently low, an advance is required from CO, and that amount taken from end shoulder as well, to straighten top of back from line A to D, as the shawl collar will not give as good lines if of too wide fold at back. The second is for notch collar effect. The standard collar gives the change for shawl roll. The amount of lowering AO is taken from forepart in cases of low roll as opposite to that of short roll in adding to collar. Observe all previous changes in the different forms.

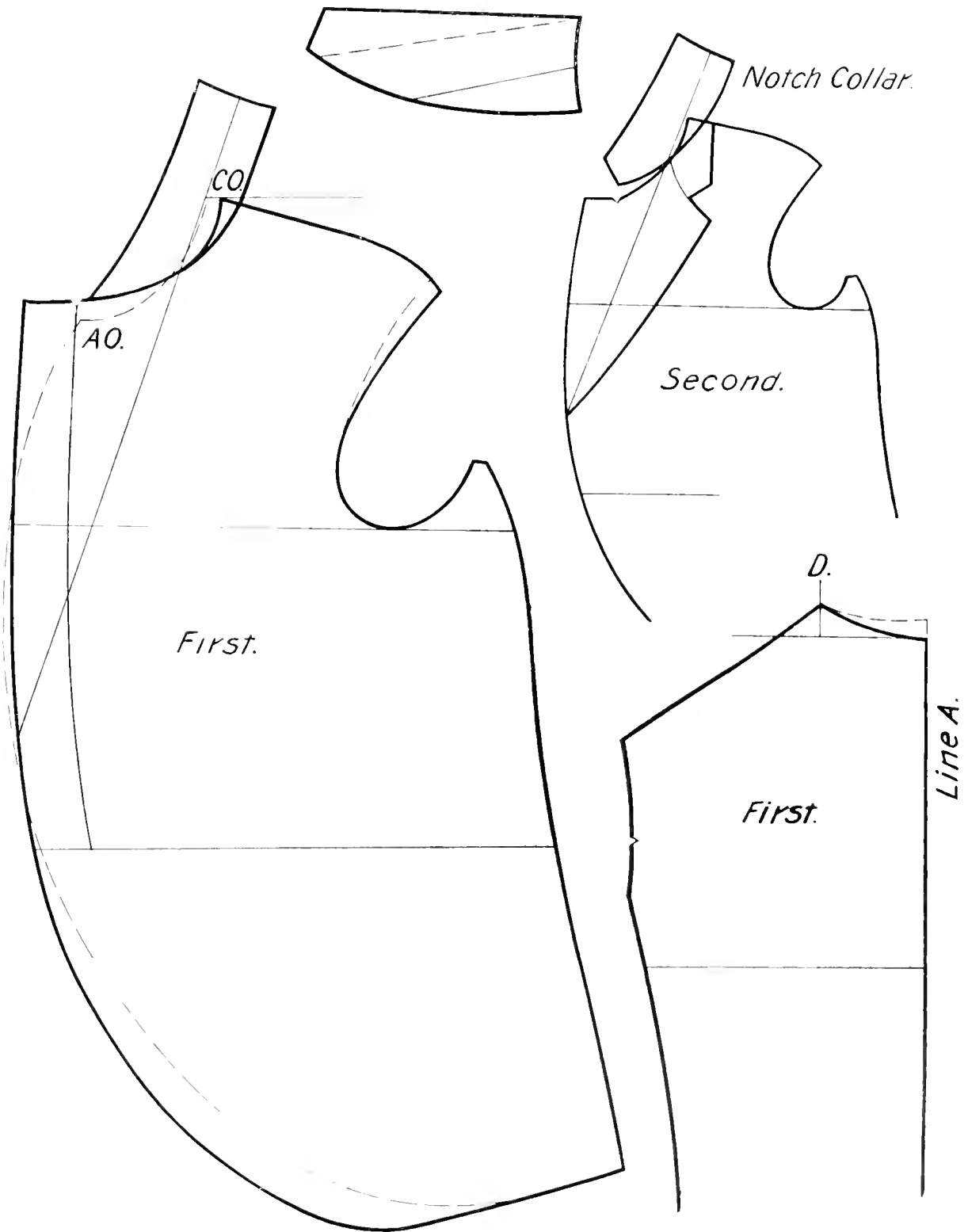

TUXEDO—SHAWL ROLL.

TUXEDO-PEAKED LAPEL, WITH COLLAR.

THIS is formed much the same as the Albert or any garment with lapels cut off, in so far as shaping forepart down (if for low roll) from AO as three-eighths down and three-eighths opening from line BO; the second showing effect when lapel goes to place. The collar in this case from standard is well to take a part from step at AO, as it will give a better roll, while all required can be taken from either collar or fore part front. From AO down locate collar notch step on neck high or low, as desired.

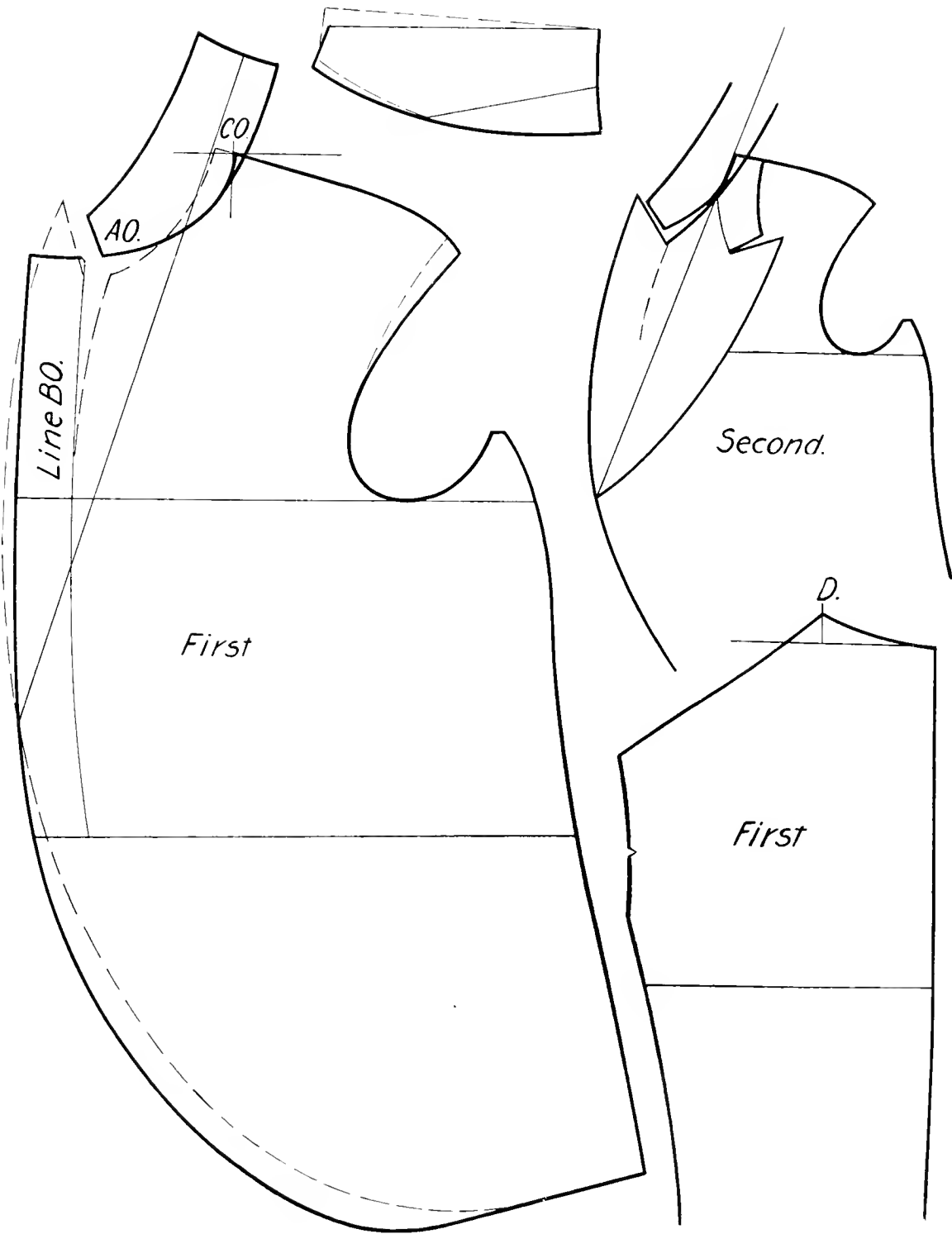

TUXEDO—PEAKED LABEL, WITH COLLAR.

TOURIST COAT.

THE best way to produce this garment is to take your customer's sack or any pattern and produce from that. First fold paper on dotted lines the width you wish for the strap in both back and forepart, then fold it under until it meets half and half the width of strap, forming the same effect as the bellows pocket. Then place pattern of back at D at center of fold, and forepart pattern at CO the same, having in mind the form as to standing. The back strap should extend down the back straight, and the forepart should extend to as near the center of forepart as possible, while it can be curved to conform to the shape. The material in this form of producing being in one piece, it can be adjusted at any time to requirements. The strap can be cut separately and sewed on, but it wastes more in seams and has not that loose easy effect of the bellows fold to open out where waist strap-band does not confine it, and is not as good tailored a garment. This is a straight front garment, and can be made to button up to AO with a turn-down collar, or a short roll with notch collar, though the button to AO is most effective.

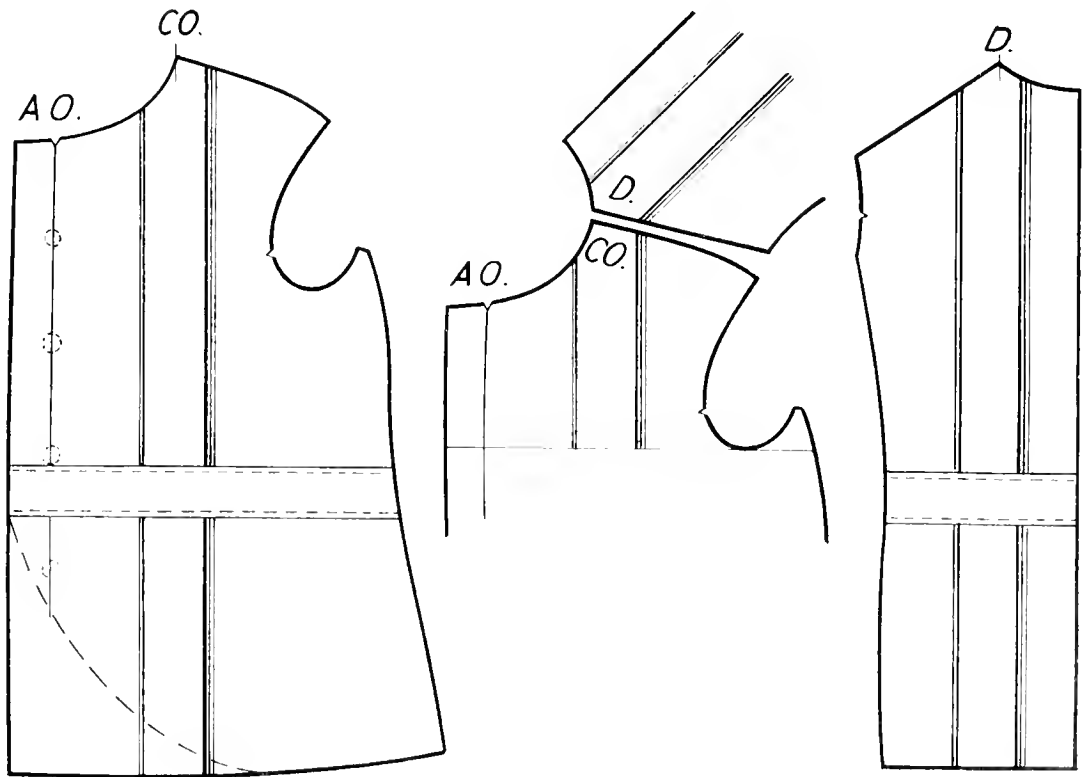
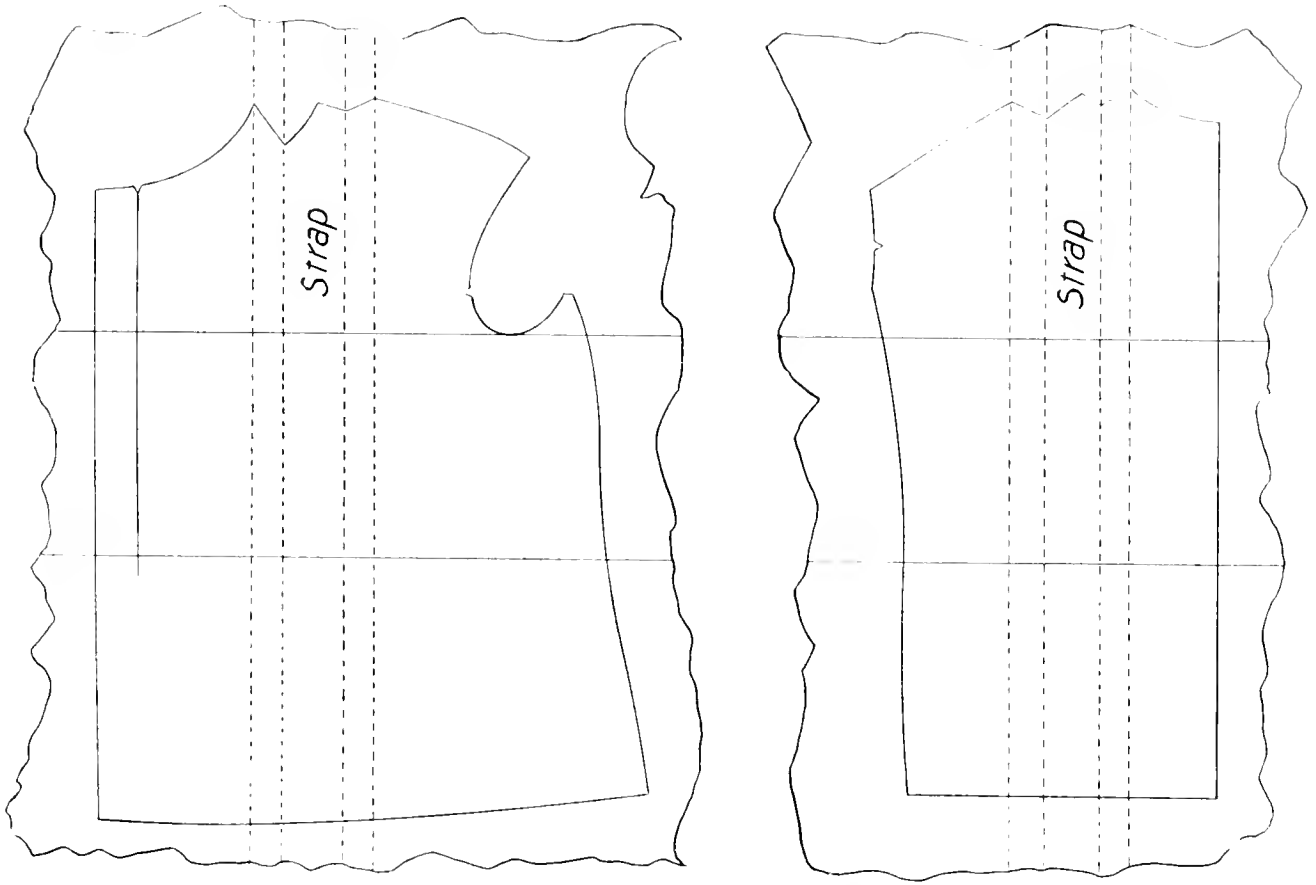

TOURIST COAT.

PADDOCK COAT.

THIS garment can be produced either from the body frock pattern or the under sack. If for a sack front and side-body cut off with frock back, it is best produced by the cutaway or any body frock. If with sack back and front, it is better to form it from a sack pattern. The first gives the peaked lapel, the second the fly front. In either case a whole back can be applied. In the frock it will give a better effect to draft each side separate, as opposite to each other, than to fold paper and use crease fold as center; in this way it is more apt to drop or take from K at top of back shoulder and not give as good shaping.

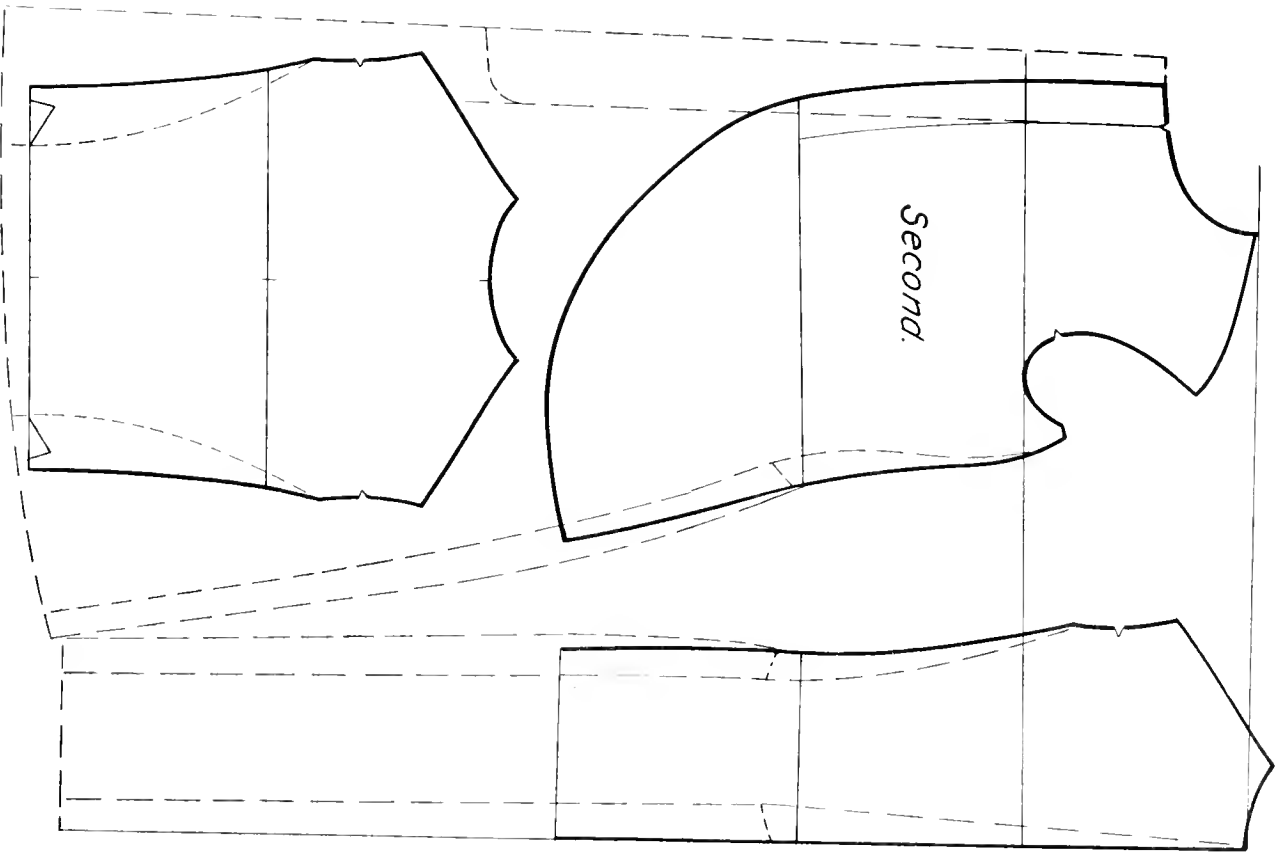
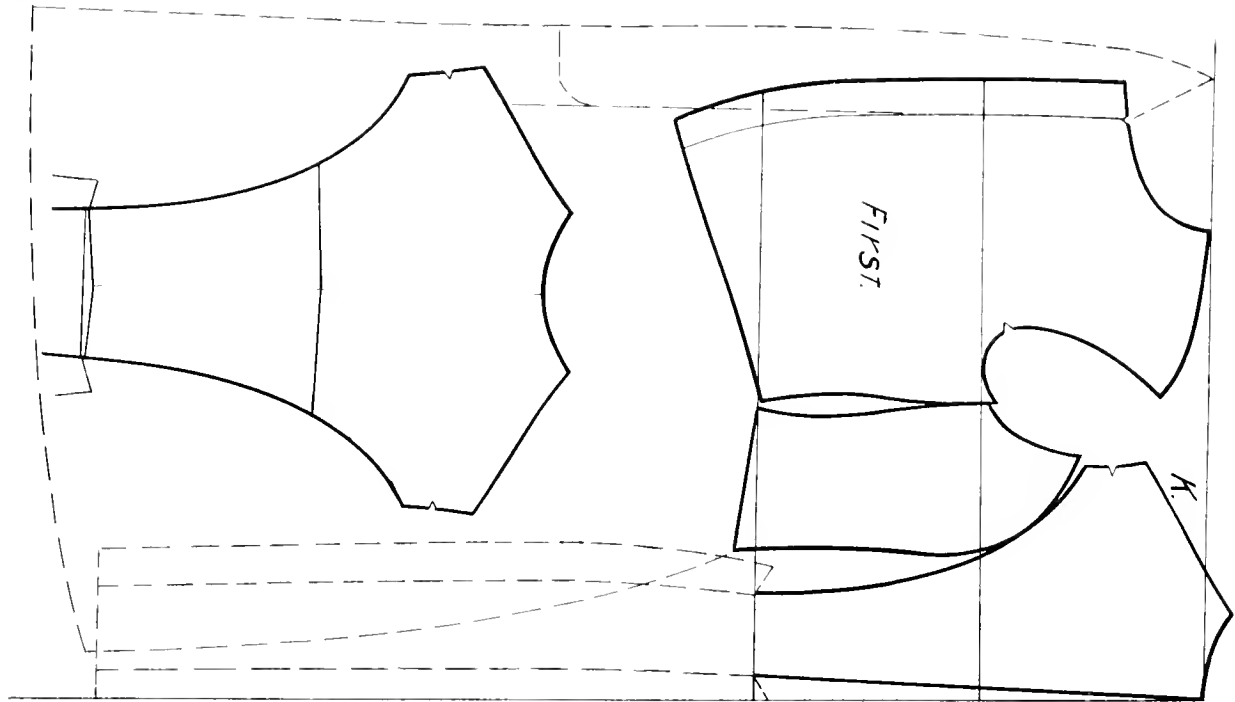

Paddock Coat.

THE CASSOCK.

THIS gown differs but little from the paddock; had better be taken from it. The front closes and buttons to neck with a standing collar. The same rule for back and front skirt formation as foundation drafts A and B are observed. This differs only in extra amount of drapery, that being one-fourth. The first is how taken off (from a pattern), the second is produced by using the one side body part. The measure around the neck should be taken from the back center to the front center to establish the collar notch, and the amount required for button stand added to it.

First.

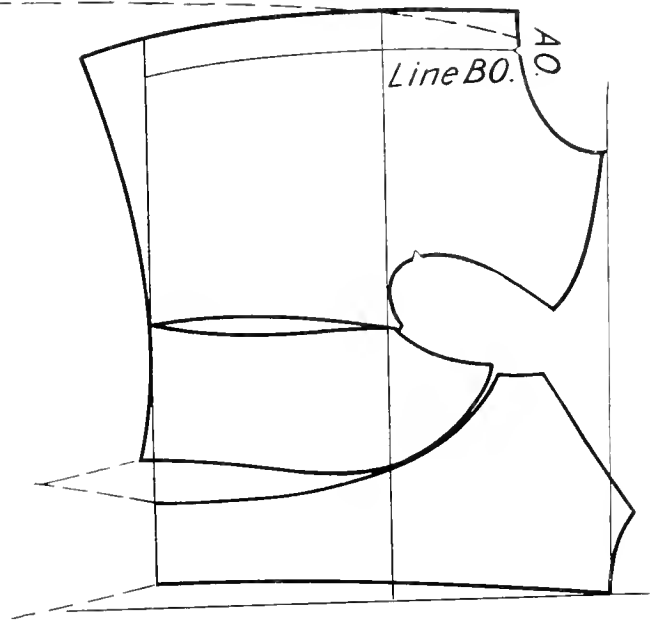

Second.

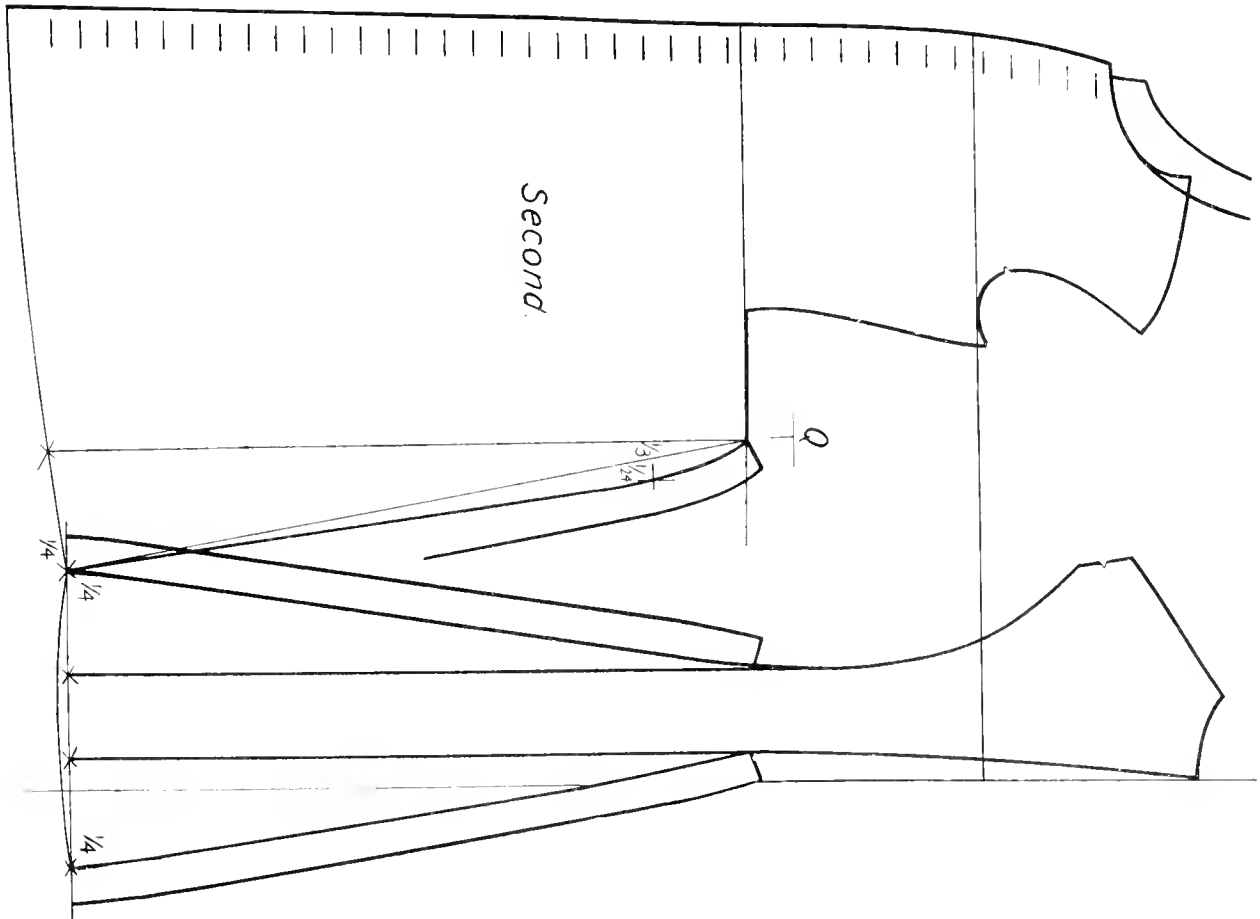

THE CASSOCK.

MISCELLANEOUS EXPLANATION—FROM DIAGRAM NO. 1.

THIS illustration is for the purpose of showing how to produce from a pattern the changes required for other effects, as from No. 1 side body to that of No. 2; from No. 1 forepart with No. 3 back and side body for a business cutaway frock; No. 4 whole back with No. 1 forepart; No. 5 whole (a solid) sleeve also to separate half and half, half at top forearm and one and one-fourth inches off the under part at bottom or one and one-fourth in from the half off the under, as No. 6; No. 6 showing the lengthening of sleeve as first marking top and to elbow, and by then going down the distance required, and by that distance it will locate the elbow as required lower; just the reverse will form the shortening of a sleeve, and in either case the cuff size in this method will re-form the same as the original; No. 7 shows how to form a skirt for extra drapery; No. 8 shows how to produce more spring if required after the garment is finished. The lowering of skirt at the pleat fold will throw back the amount required, and will also shorten the skirt at that point. If there is no outlet on skirt at bottom to replace that amount, the back will require to be shortened for the amount.

The previous mention of taking the fabric from where it is not required and placing where it is will be well illustrated above, and it is well to have it always in mind as being one of the most essential governings in the business.

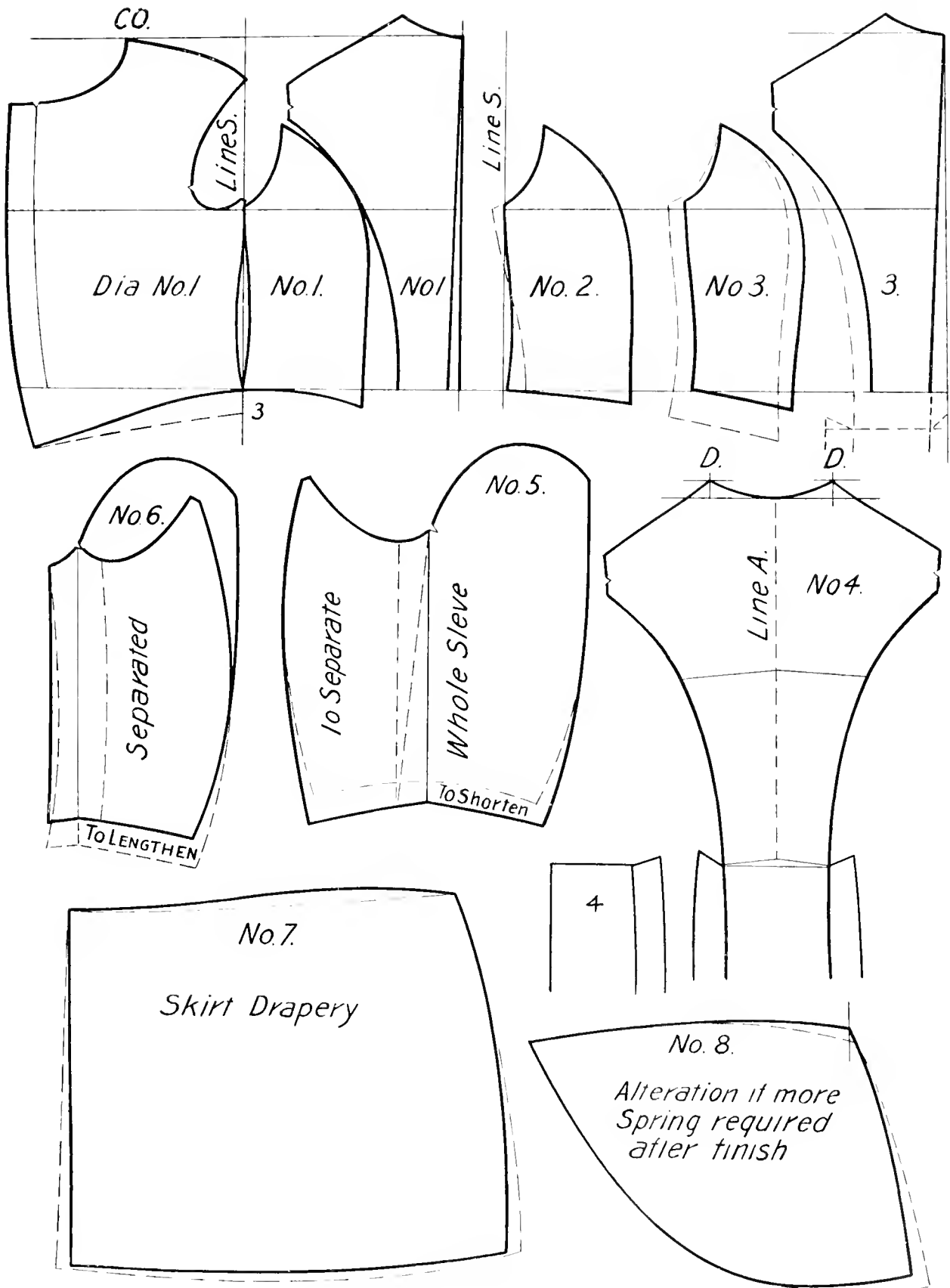

EXPLANATION—FROM DIAGRAM NO. 1.

SYSTEM
OF
PATTERN ILLUSTRATING VESTS



MEASURE SYSTEM -TO TAKE AND APPLY.

TO take measures for the vest in the use of patterns, those given with illustrated diagrams of rules are all that are required. Starting the first, second and third at back center of neck, fourth around the larger part of blade and chest, fifth around the waist. It is well to take two measures at the waist, one at the smaller and one at the larger as to button, the same as would be in trousers for any corpulency of form. As a vest must button below the space of smaller waist, the lower measure would, if only one were taken, work the surer results.

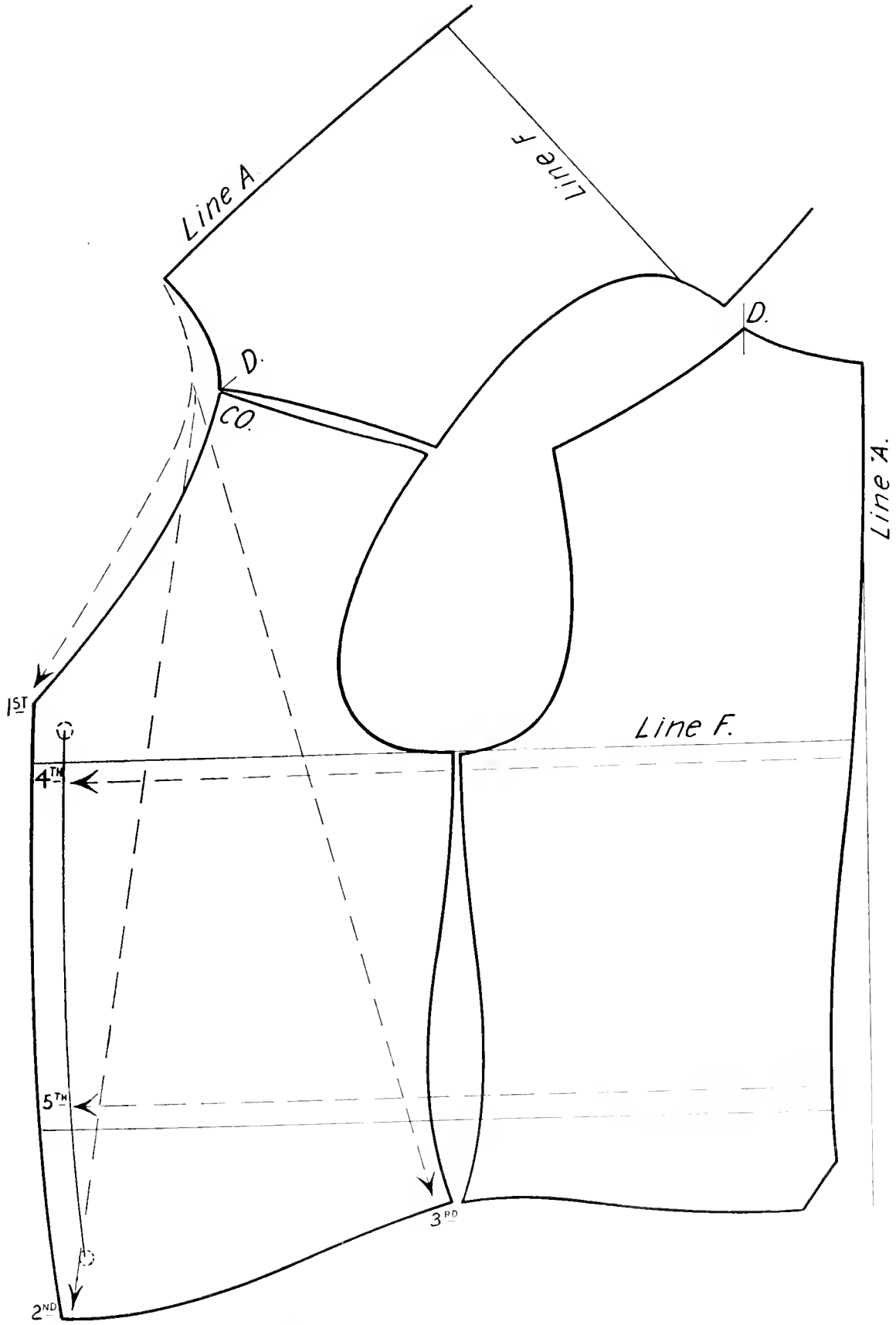

MEASURE SYSTEM—TO TAKE AND APPLY.

SINGLE-BREASTED VEST (WITH COLLAR).

THIS can be used either with collar with stand cut on as No. 2, or with collar formed by the opening and seamed on seam to seam as shape. In the case of No. 1 the point CO remains the same as in draft, and being the same as that of the coat, the amount of coat collar stand distance above it places the vest without a collar stand that much lower. The one No. 2 with collar stand will require the amount of stand taken from CO. In either case a collar only extending on forepart from the opening to CO makes a thinner and less bunched back than one extending around the back. No. 2 back shows how any extra amount can be left on back at top to turn under, and, by placing a thin stay between, will give sufficient strength and a much better effect. The back strap has much to do with a good shaped front, and is many times placed too high to have good influence. If it stands out from the form, a good remedy in this case, or in one of extra corpulency, is the placing of a button at the extreme front and working a buttonhole under, as in a fly.

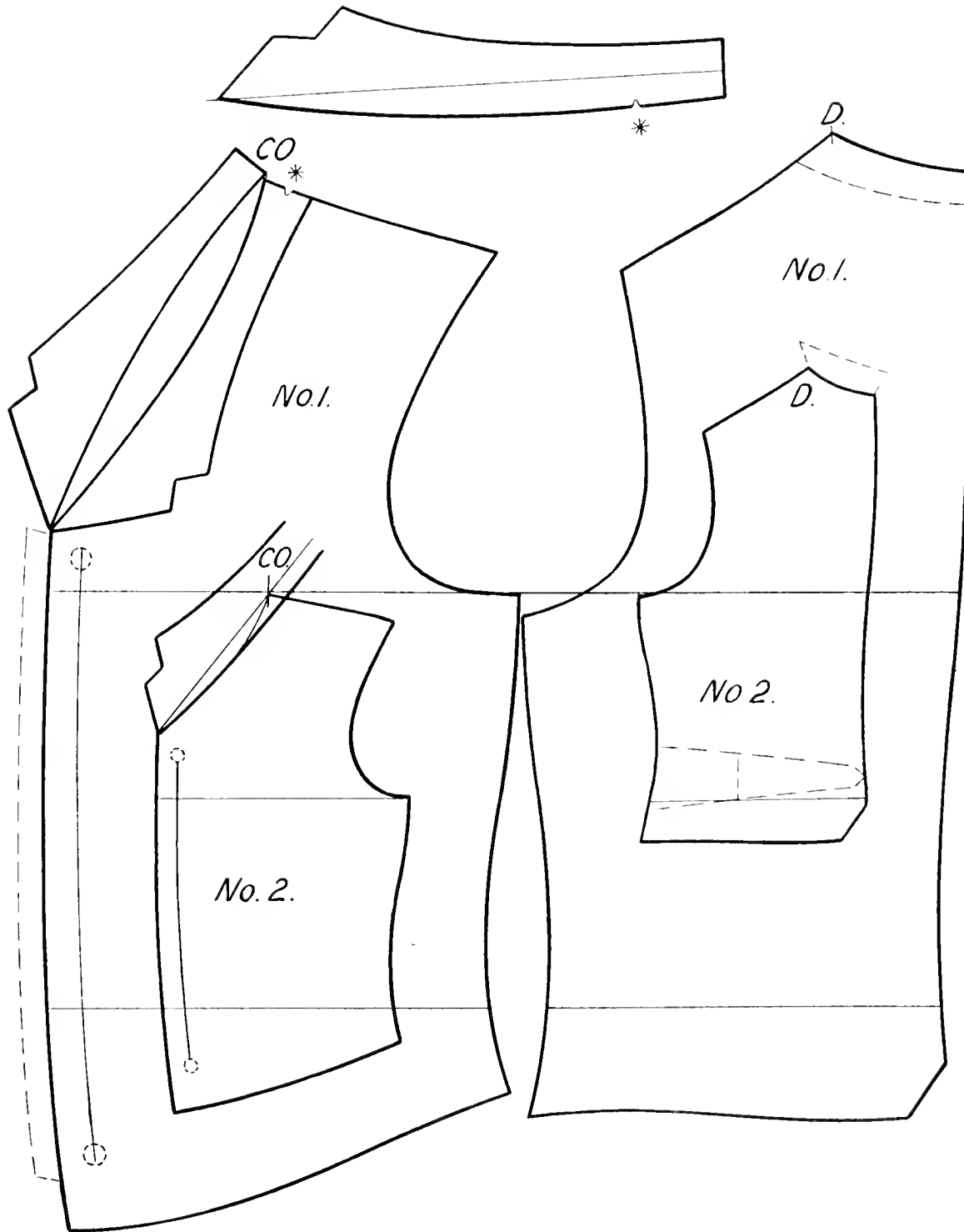

SINGLE-BREASTED VEST, WITH COLLAR.

L. & F. C.

SINGLE-BREASTED VEST (WITHOUT COLLAR).

THE effect of this vest is best displayed by the artistic line of front shaping. Too much of a curved line at opening has more of the effect of having been for collar than having been taken off. After establishing the distance for opening, the front can be gracefully lined below to form a good shape, as the top button can be placed well below the opening, and with better effect. The pockets look best in line with the bottom of vest; the small pocket on opening line goes inside on the facing, and is very useful to those using eye-glasses; the middle pocket is useful for the watch, where persons use both upper and lower for other purposes. In fact an extra pocket or two will often express more than many mentions, as they are the proof of a desire to please.

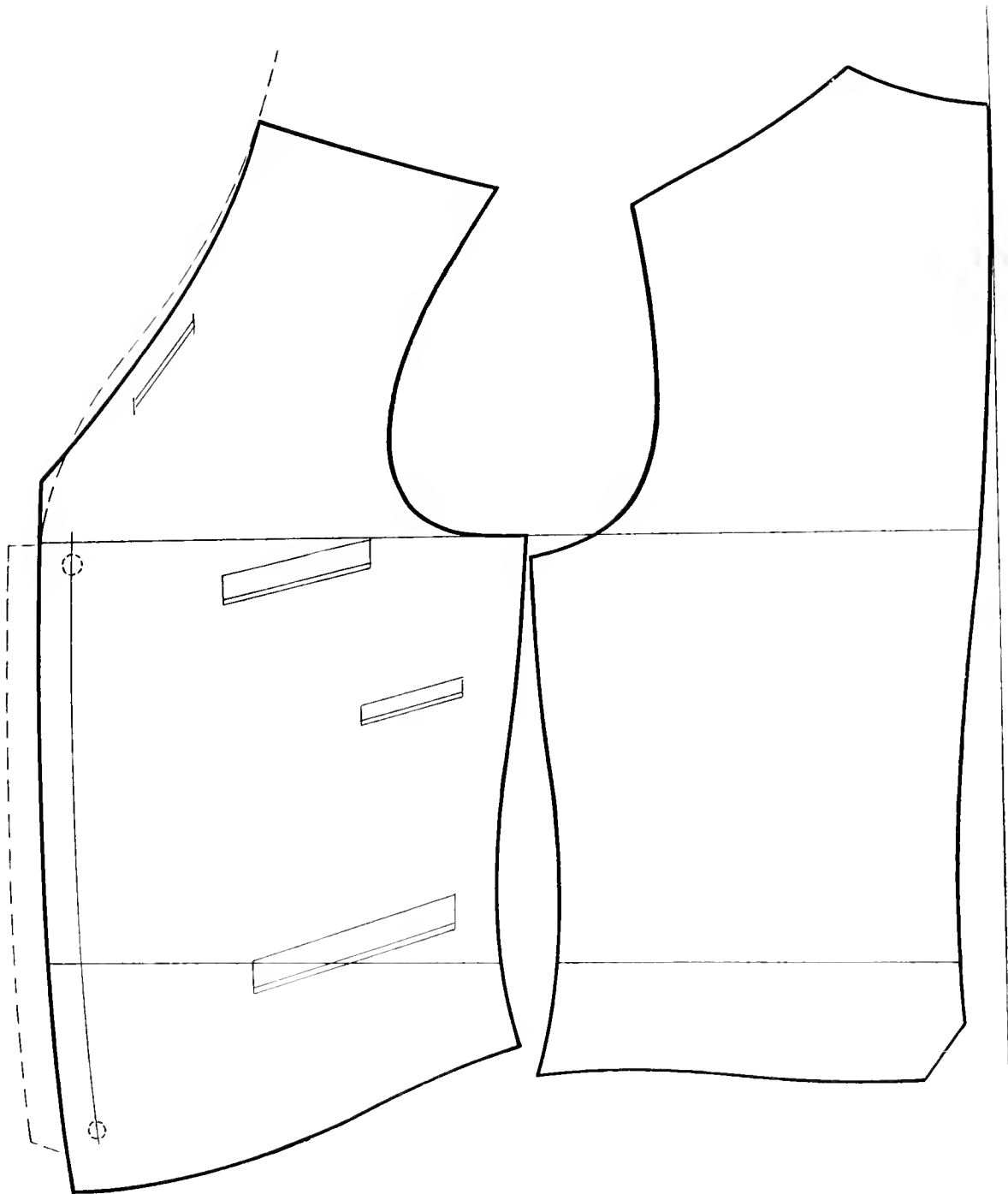

SINGLE-BREASTED VEST, WITHOUT COLLAR.

DRESS VEST—SINGLE AND DOUBLE-BREADED.

THE only differing of this form from the single-notch collar No. 1 is the formation of front opening, and that is governed by the prevailing style. This, like all low-roll or open-front garments, requires more advancement from CO. In the dress vest, especially that of a heart-shaped front, there is often too much of a curving-in at line F, showing too much of an opening. The double forepart to dress vest is simply the extending of front as desired.

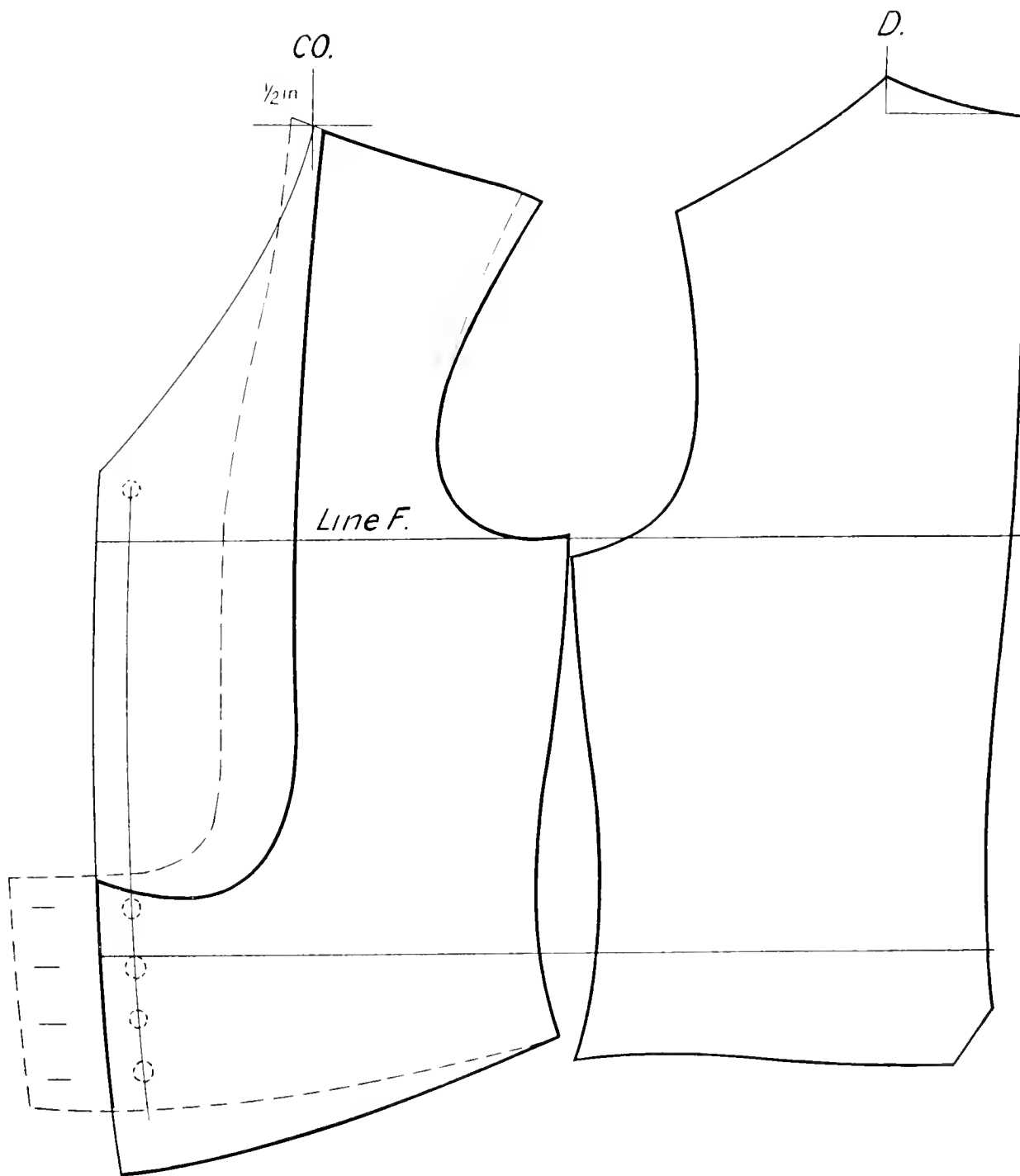

DRESS VEST—SINGLE AND DOUBLE-BREASTED.

VEST- ERECT FORM.

THE change at CO, D, and at line A, will show that of the extra erect. The line BO is for button stand, X line for front edge, and that forward from X amount for outlet. The outlet amount is only to go on the button stand side, the under, or left, side of vest front material to be cut off on the line of X, leaving only that of the top or right side standing. This will apply to all vests where no eyelet-holes are used for the buttons; where eyelet-holes are used for buttons to clasp in, it is best to leave inside facing loose on button side, to cover the button shank and clasp.

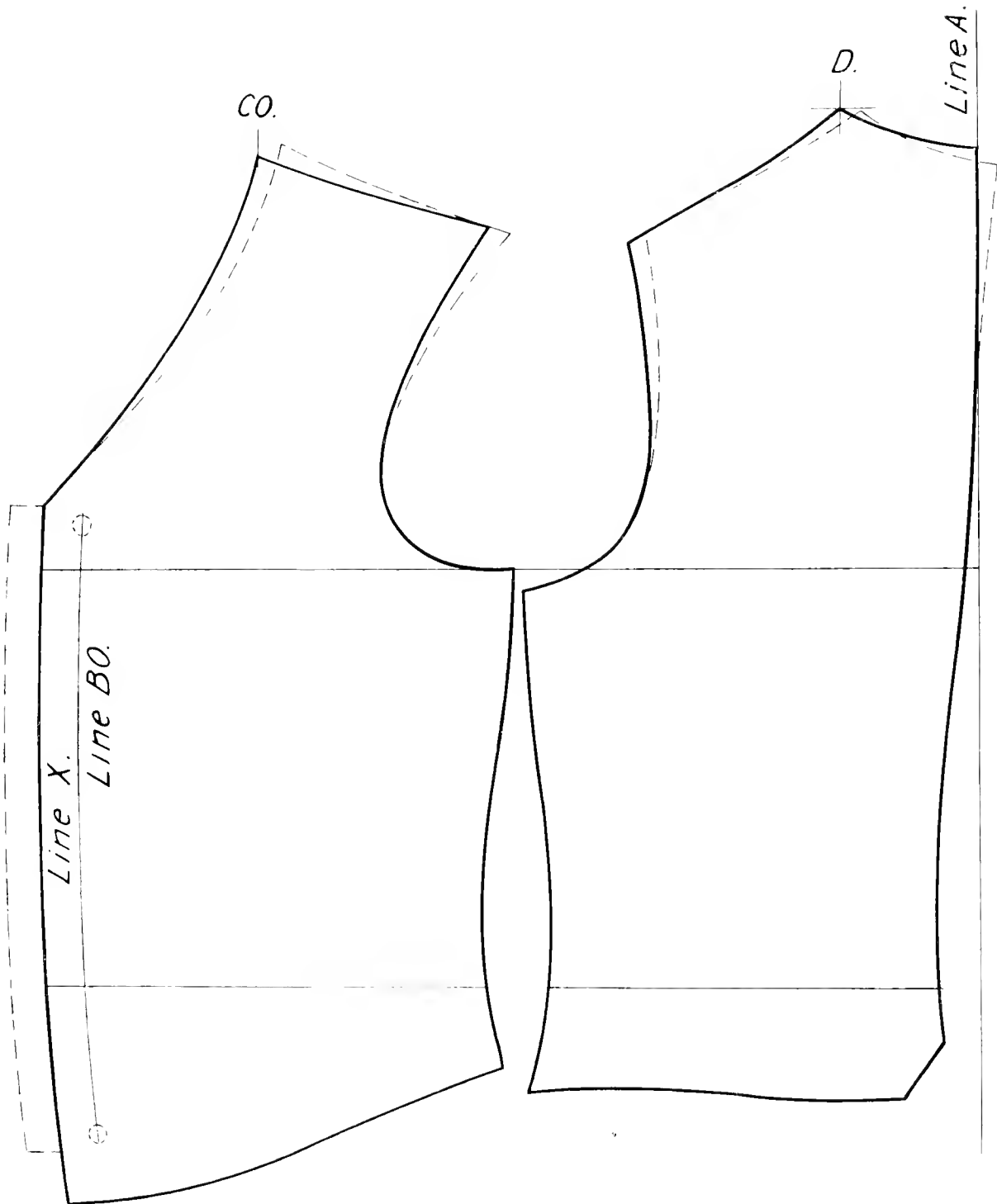

VEST—ERECT FORM.

VEST STOOPING FORM.

THIS form above line F is just the opposite of the erect, and while in the erect it is not essential to make any change below line F, it is more important to make change in the stooping form, as it is very essential to have more front at waist line G, and for that amount forward it is best to take it from the back and so place.

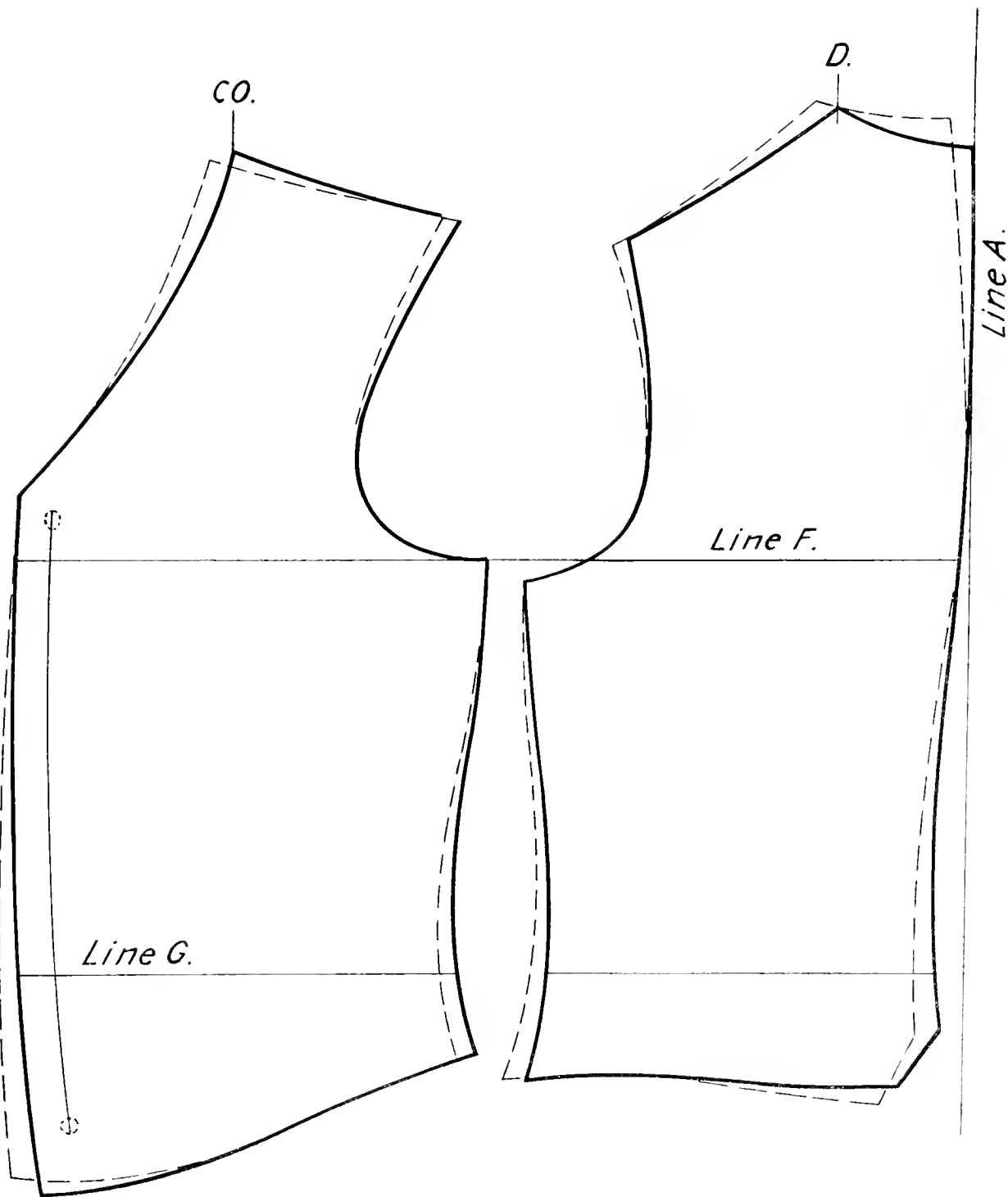

VEST—STOOPING FORM.

VEST—CORPULENT FORM.

THIS illustrates a three-size increase at the waist, also how to cut for drawing-in of bottom. The scale given with this is for use in all vest diagram illustrations given.

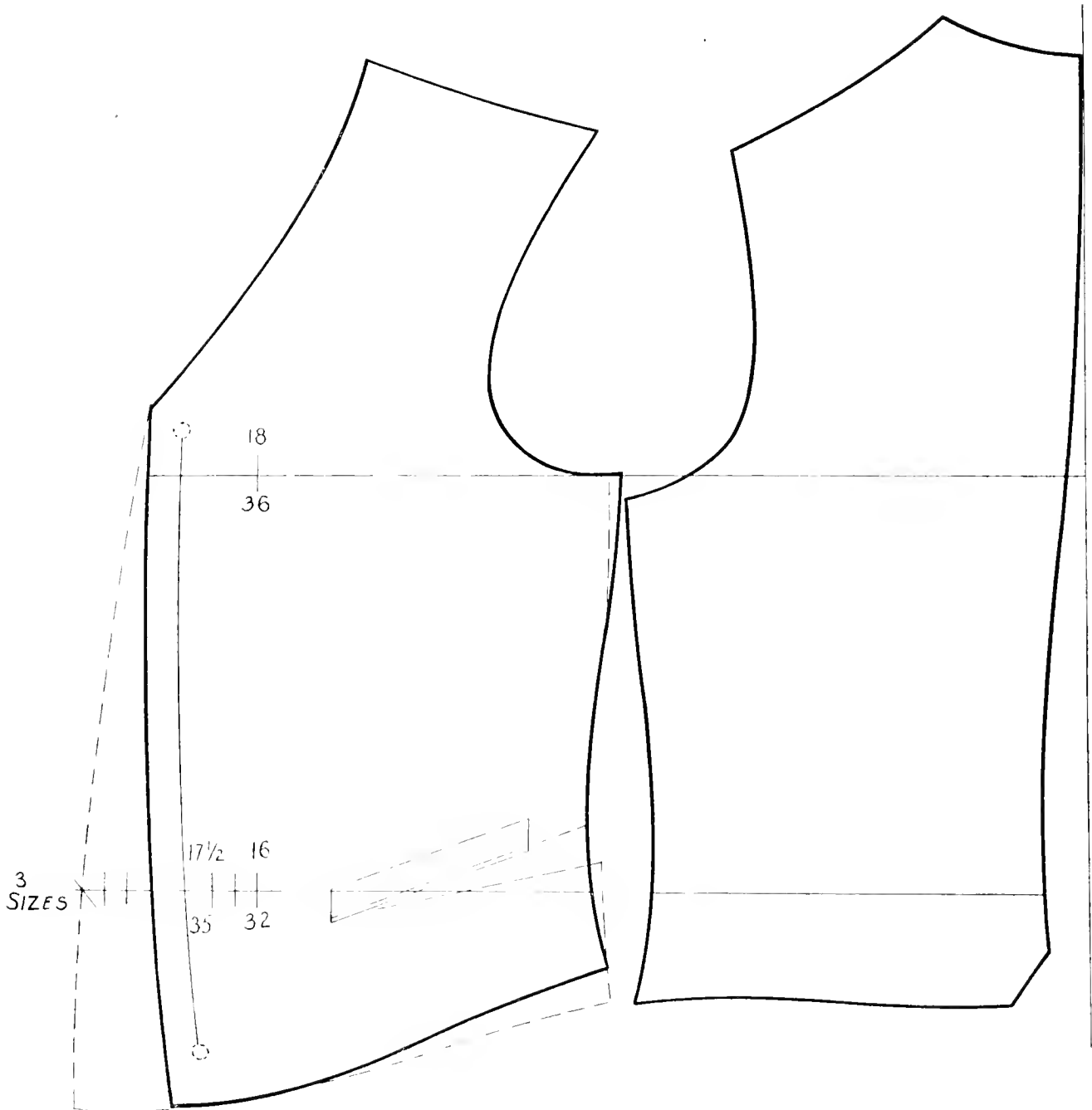
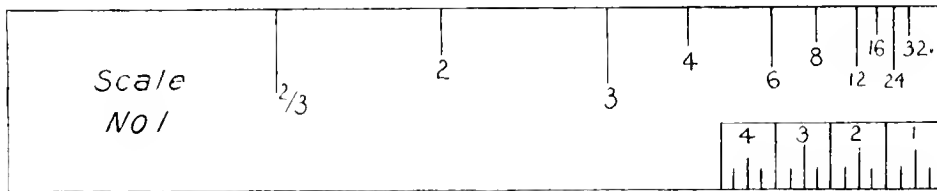

VEST—CORPULENT FORM

MILITARY VEST— TWO FORMS OF COLLAR.

THIS illustration will answer for any vest closing up to the neck, and can be used either with a standing or rolling collar; if with rolling form, collar No. 2. This vest is often called for as a winter or storm vest. In producing it it will be necessary to take the measurement of the neck from back to front center; that will establish for collar notch and add the usual button stand amount to it. The neck gorge is formed for the collar one-sixth down from line B.

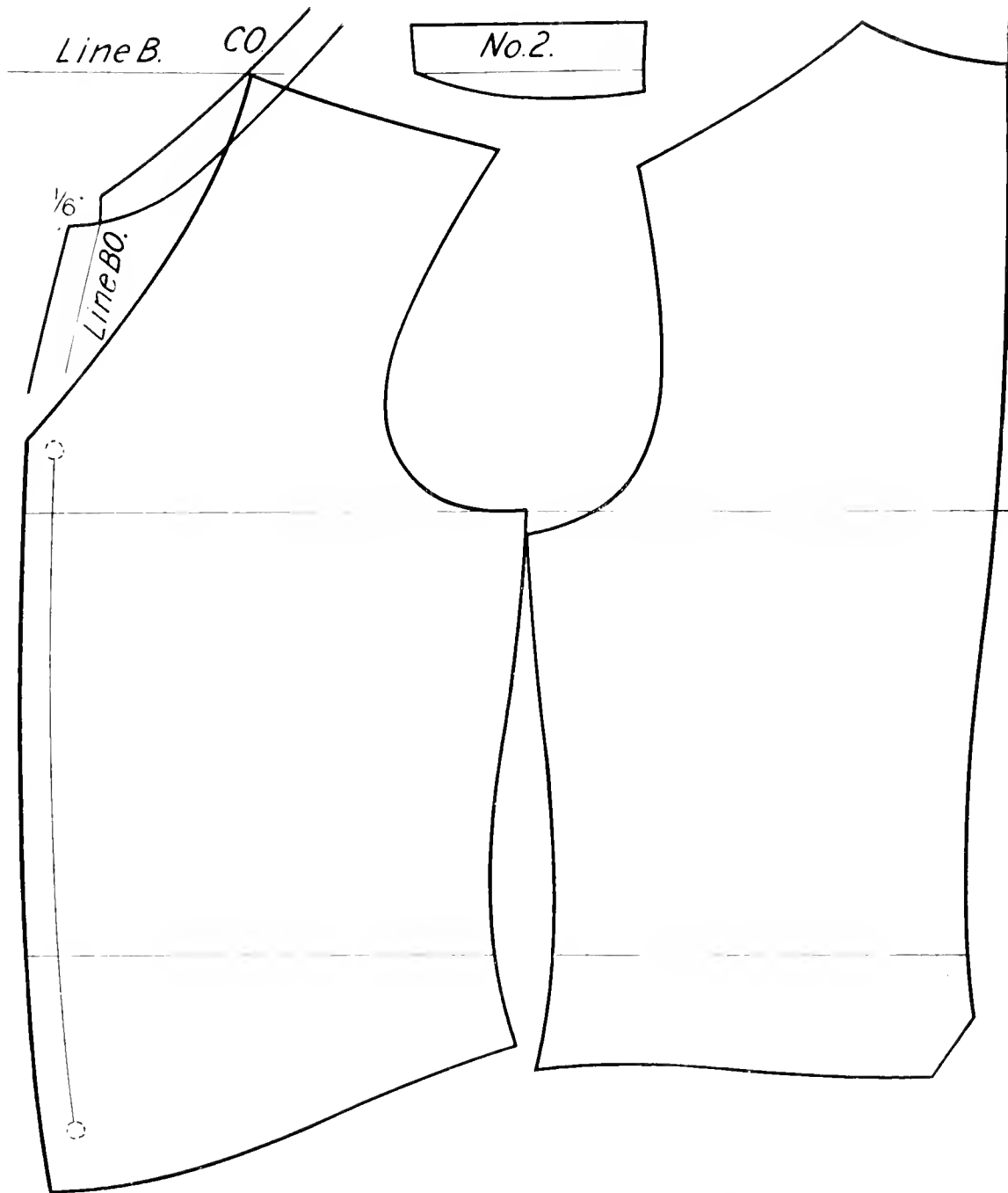

MILITARY VEST—TWO FORMS OF COLLAR.

DOUBLE-BREASTED VEST—ONE-PIECE COLLAR.

THE only change required from the single to produce the double, use button stand line BO as guide in determining whatever amount of spread or double is required (BO being the line of opening in all cases, either single or double) ; from two and three-fourths to three inches out from BO is conservative. In measuring for any vest to double over, take the measure just the same as for single (and beyond that it is optional as to how it is shaped). A good line is formed by the continuance of the same extended curved line.

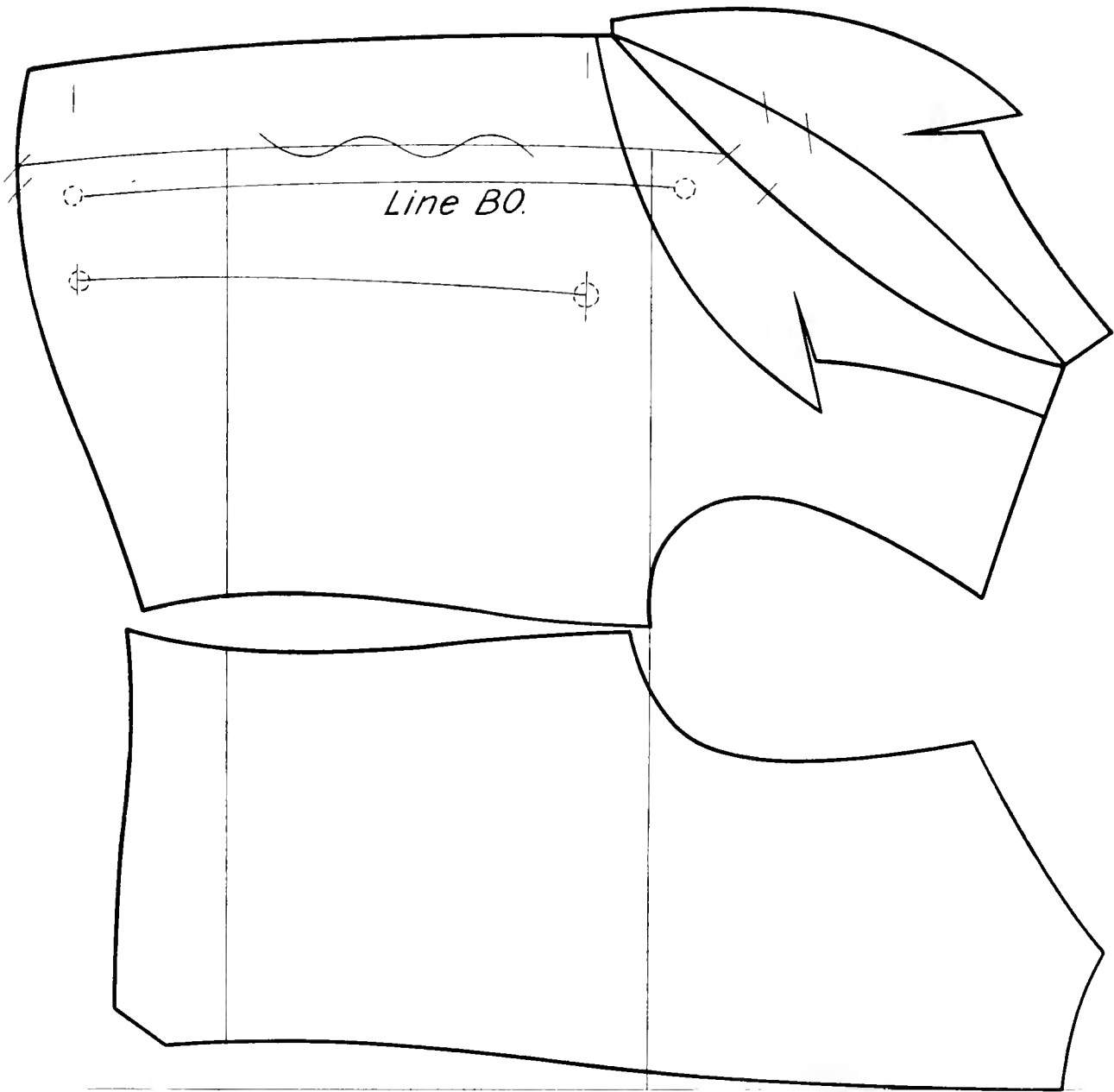

DOUBLE-BREASTED VEST, ONE-PIECE COLLAR.

DOUBLE-BREASTED VEST—THREE-PIECE COLLAR.

THIS vest is the same as that of the one-piece collar, with the exception of the collar showing three instead of one piece, also the taking out of a V-shape at the opening line and at the bottom, if required.

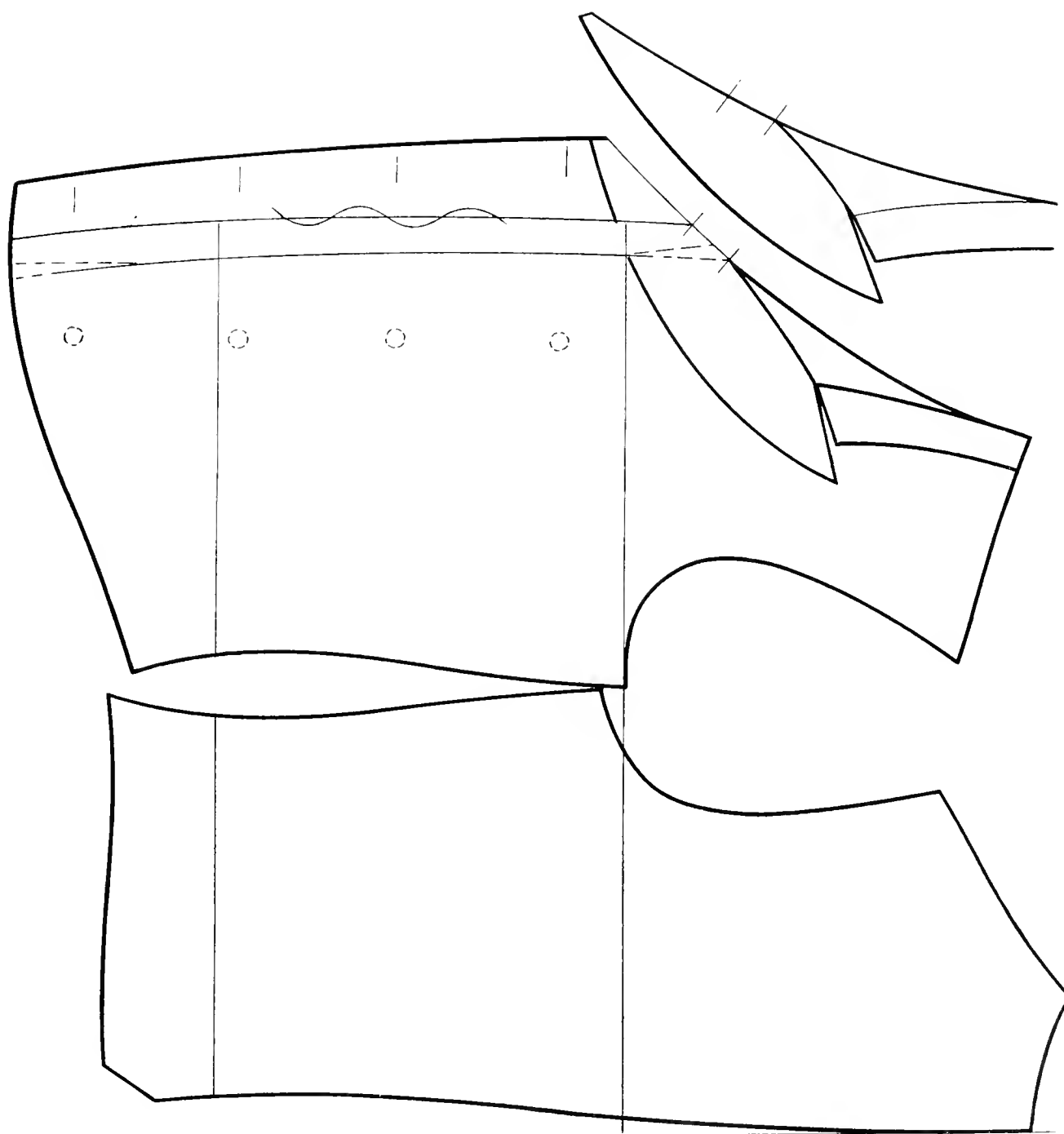

DOUBLE-BREASTED VEST, THREE-PIECE COLLAR.

DOUBLE-BREASTED VEST—ALBERT.

THIS vest is the same as the Albert coat to waist in formation. In this the collar is the same as a coat collar, and requires the taking away from the front shoulder-point, CO, that amount of vest collar stand. The collar is formed to back center and made up loose to permit of vest rolling to any opening desired, as No. 2 illustration. It can be worn opening to bottom button or closed up to neck at top button. The lapel is cut separate in this (the same as a coat). The neck gorge depth from line B is one-sixth.

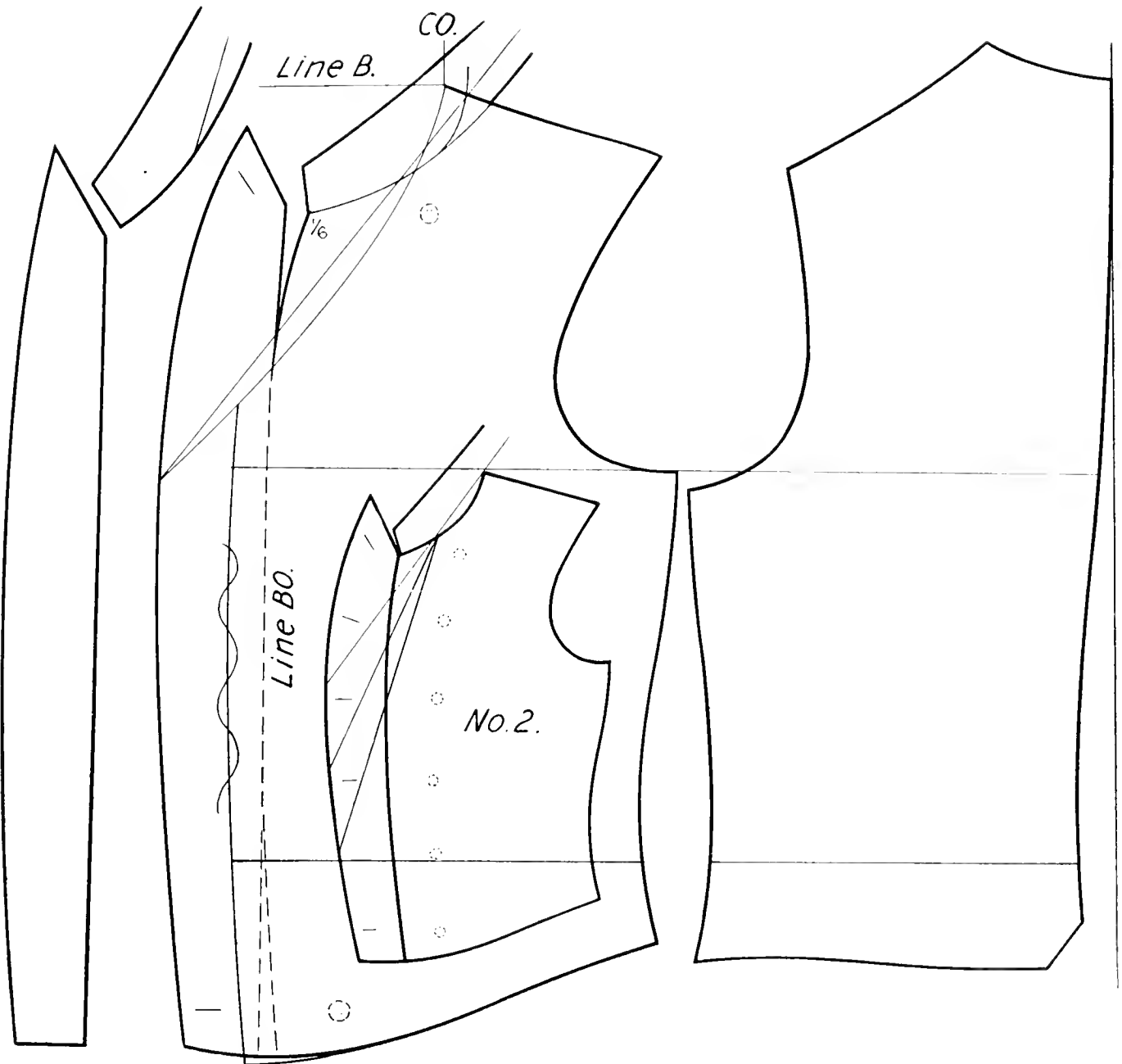

DOUBLE-BREASTED VEST—ALBERT.

CLERICAL VEST.

THIS illustration shows how to produce from the single vest pattern by placing in opposites, and, like the military vest and the Albert, goes down from line B one-sixth for neck gorge point for collar. The center from CO to CO is one-fourth and one-twenty-fourth, and, like the military, requires the neck measure taken the same to locate collar at front and to find out the amount to take out a V-shape. The first is represented when buttoned over, the continued; second, as closed in front; third, the piece attached to back to go under for the first to button on to. This third is so constituted that the front may be of a single fabric. The collar is cut to conform more to the shape of the neck, avoiding too much of in-working. Illustrated explanation on next page.

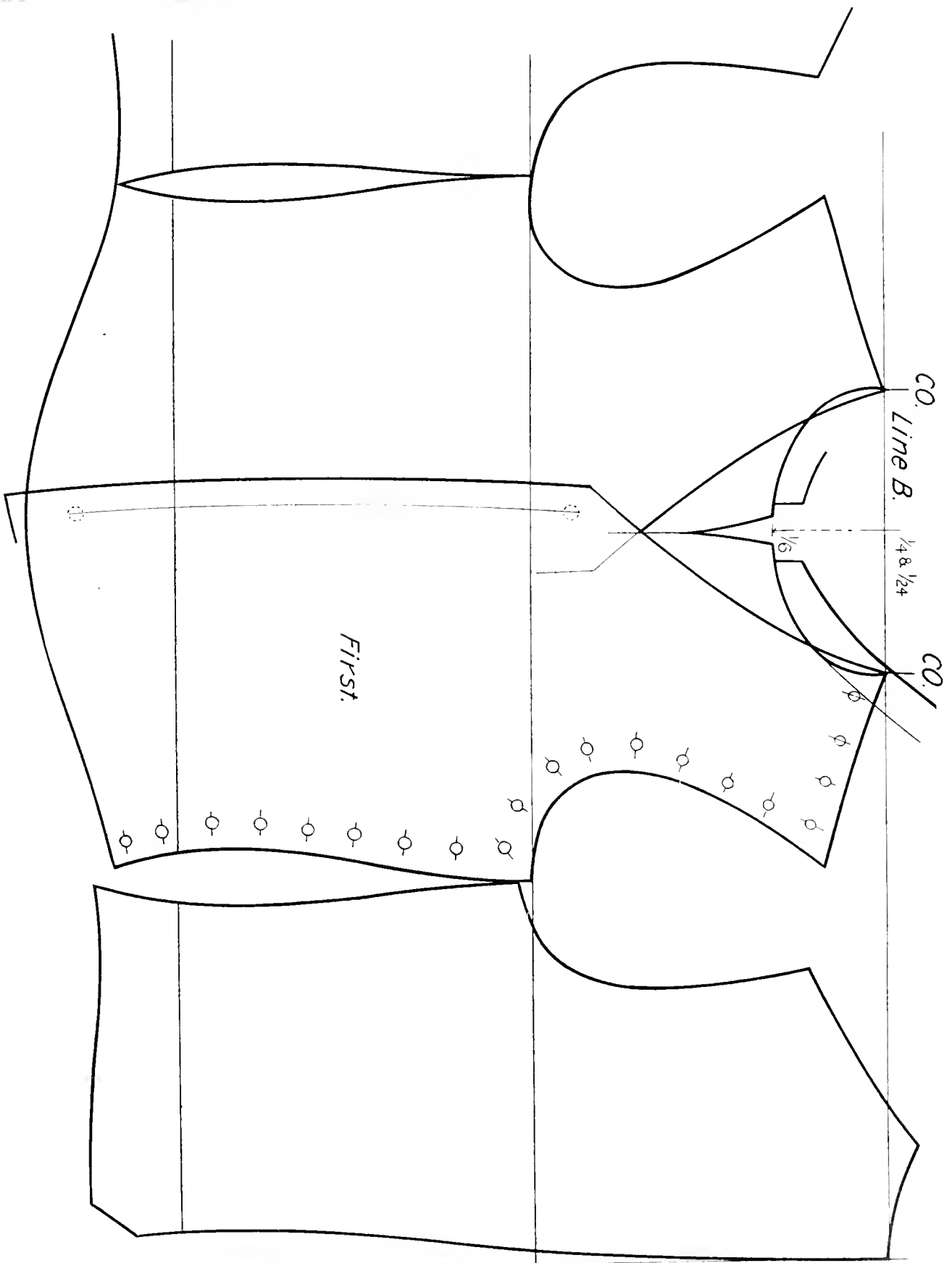

CLERICAL VEST—DIAGRAM.

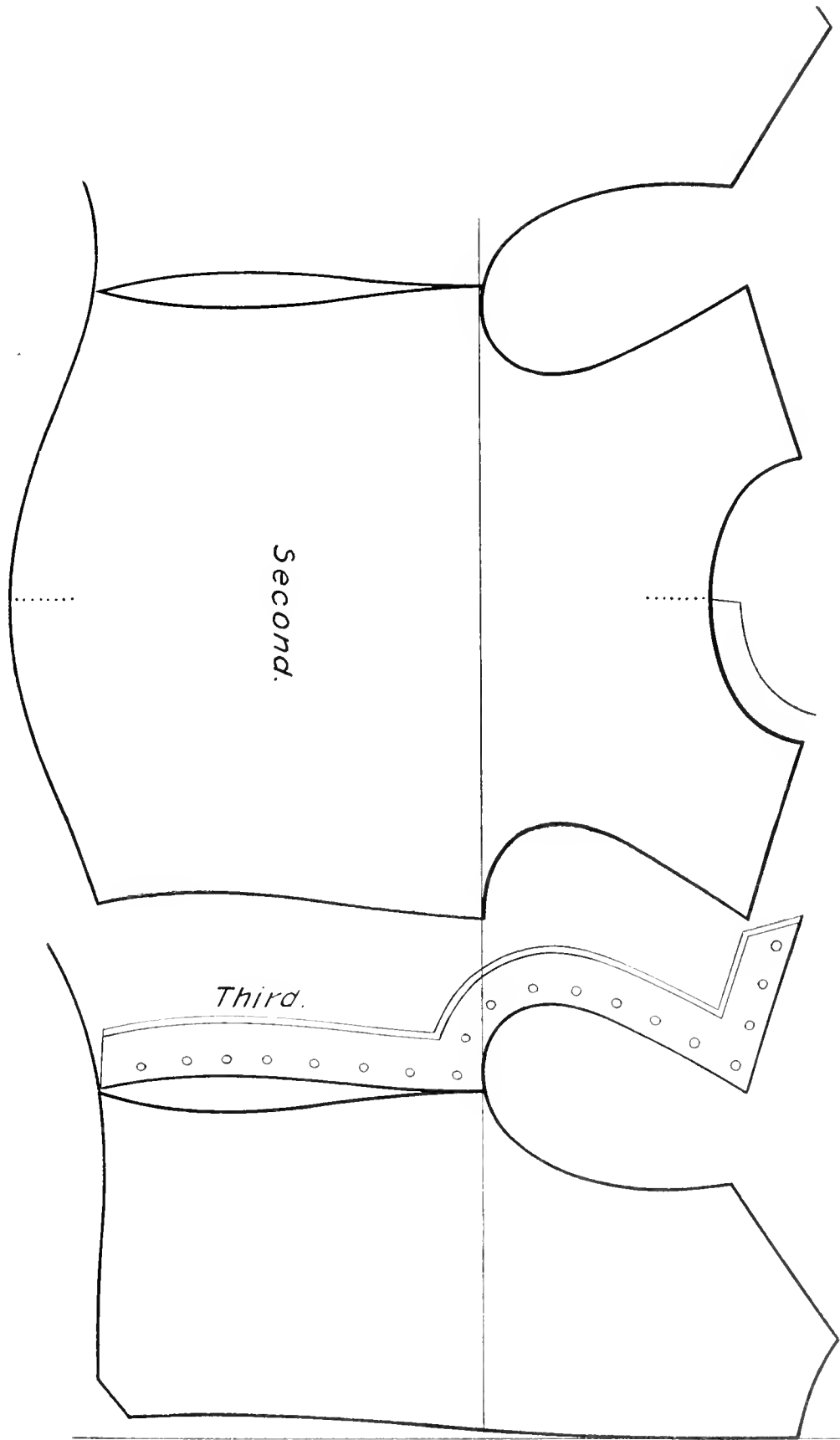

CLERICAL VEST—ILLUSTRATION.

HINTS
AND
SUGGESTIONS

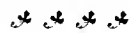

HINTS AND SUGGESTIONS.

THERE are necessary qualities required in a cutter, not only for his own success, but as well that of his employer. One alone will not suffice to reach the high grade mark, while it may go as inspection of a certain standard; all can, if willing, make advancement to better existing conditions, if not endowed with too much egotism. As it requires a combination of several, it is a little difficult to form and meet all criticisms, as well as to find all in one; and to place the number is as hard as it is to enumerate the conflicting ideas coming up in garment producing. With those who are endowed with many gifts it is easy, and they are fortunate; but those who are not so endowed must work the harder to acquire the same results, and while all cannot do so, a close application will be of great assistance. The most essential quality is scientific art, and that can be acquired by observation and practice, and no profession can reach a high grade without it. Art is a system of rules which requires the scientific in all builders or productions of skill; it gives one importance; it solves problems which the experienced know are of frequent occurrence, confronting one most certainly in this business. Good judgment is also of much value; and it is well to cultivate how to dress in a stylish and tasty manner, as much depends on appearance, not only for your success, but as well that of your employer, and it is also the impression that will have great weight. Study to harmonize the blending of colors, as often a salesman will sell what in different garments do not harmonize either as to color, complexion, eyes or hair of the customer. Many are color-blind themselves, and do not understand why an article is not pleasing or becoming to the wearer. The combination of coat, vest and trousers, when all differ, is not a good selection, but there should be two of a kind, and all should be harmonious in color and blending. If occasion requires you to dress a window for display of material, observe well the effect as to arranging the fabrics, the colors blending in harmony one with the other, as two or three may be effective separately if well arranged as to each and every one, and so arranged as not to detract one from another, as a blue and brown, a blue and a dingy gray with a dull gray, the dull helping the bright and the bright harmful to the gray—red will brighten and enliven most all. The dressing of the neck should have much attention too, and dressed so as to harmonize with the garments being worn and as occasion requires; and then, too, the eyesight is not alike in all, as oftentimes that which pleases the eye of one would be the opposite to another, and sometimes what looks pleasing to the eye to-day may not please you the next day. A striking contrast, if well blended to harmonize with the garments worn, is much more attractive than too much sameness of matching in dressing the neck. Avoid selling your patrons unbecoming fabrics or a style of garment unbecoming to their form, and always advocate, if becoming to your customer, the prevailing fashionable fabrics. Study form, as all cannot adopt the same, and there are always varied styles to select from. Some long neck forms can dress the neck with a five-inch collar and wear becomingly a short double-breasted sack coat on the loose box order, when the short neck and short form would look very much in a heap and in bad form. Always use your influence to help the corpulent or short form, and suggest for them the cutaway frock. In the corpulent the cutaway frock exposes his form the least of any style of garment, but it is in most cases the corpulent person who wants the straight front coat, thinking to hide his corpu-

lency, and not seeing how pronounced it makes him look, and that it should be avoided only when occasion requires of one either a D. B. Frock or the Dress Coat. The tall and slim forms are usually of the same impression, only, of course, thinking the opposite. He requires the long coat only as occasion necessitates, and uses the D. B. short sack as giving the best effect. The short or stout will appear taller and in better form in any garment other than the short sack of any design. To gain the confidence of your customer is one very strong point towards success, and never abuse it and you will make lasting friends, who will follow you and bring with them others. It is well, therefore, to make other studies than the mere one of producing garments, as confidence, once gained, will make your work easier.

The tailoring business, to be made a success, is never learned too much or too well. Dress yourself as strikingly and as attractively as circumstances will allow, but never on the loud order. Do not wear ultra style in any form for the sake of so doing unless your form is adapted for it. One can dress stylishly, but if not becomingly, the effect is poor and will fall flat. As remarked before, there is sufficient in use to enable all a good selection for a good appearance. Never talk a customer out of having a garment if becoming to him, for the reason of not knowing how, or it being too difficult, to produce, as the chances are you will lose a customer, if not his confidence.

A little outlay will make you money, and it is better to borrow money to buy knowledge first than a stock of goods without the knowledge, as the chances are you will not be able to dispose of the goods if you have not used your judgment, gained by that knowledge, before purchasing the goods. Not sufficient knowledge is expensive for a cutter, too, as well as his employer; but when you have gained it you have an asset and capital, exempt from taxes and not to be foreclosed and sold on judgment sale; and, above all, avoid having that order of knowledge, when young in experience, that will not allow taking in more. Value a good tested pattern you have produced, and by it produce others; as, should it be right for Jones, and Smith should require it a size larger or smaller, alter it, and you will soon find yourself working with better results and less trying on. There is no way a cutter can make himself of so much value as to advance to a point where trying on is not necessary. It is more the lack of confidence the customer has in a cutter that he expects to try on than the wish for it and the excuse that all expect it. There is no better way for a cutter to raise the standard of scientific tailoring to a high grade than to reach that standard where it can be avoided; no way of gaining more confidence and so strong a following; as, when once established, the continuance will go far to avoid the annoyance of it. Without the trying on one will gain a reputation well deserved, and will compel, by force of results, a cutter to rely more on self than on trying on for them. Once established, it will make a marked distinction and elevate a cutter, and he the tailoring business. There is many a garment harmed by trying on, and there are many that after being tried on require corrections, and often there is as much to correct when finished after trying on as before.

Avoid in measurement the calling out of the *cigars* unless afflicted with much prominence of self and have made a study of the proper attitude required to go with the effect, as it has no other effective influence in garment producing but misleading to good judgment in the accuracy when taking it. Affectation, if endowed with it, is bad form, and much worse if acquired—that is best used on the theatrical stage, where it will receive more applause than in any branch of the tailoring business, as the followers of the admiring ones are in the small balance, and even those who do admire it will smile at the appearance of it as out of place in others, and, as if assuming familiarity in their set and not being of that set, will look upon it as assuming over them a superiority.

Never allow advancing years to influence in any form of appearance or thought. Keep young, so that you do not get too old to observe and learn, as one is not judged by years as much as by appearance, looks and actions, and if you will feel and act old, your looks will surely

be in keeping ; but if, on the other hand, you will be judged as still of some value, there will be a place for you, as the old of to-day is a perplexing problem to many minds. Never, if in good health, is one too old for usefulness ; there is a place for all deserving seekers, if they do not rely on others to find it for them. The question is often asked, What is to become of the old in the tailoring business ? And this question should inspire the young to apply more energy and take advantage while having youth, as it is more the lack of energy that shortens the age for usefulness than the increase of age in itself. Pride keeps many from positions they could fill. There is no good reason, if in health, why any one is not of some use, and of sufficient use to be self-sustaining. Adapt yourself to circumstances and to surroundings ; and, with health, the question of what is to become of the old may be answered by it, and there will be no excuse but that of disability, caused by good and sufficient reasons.

LIBRARY OF CONGRESS

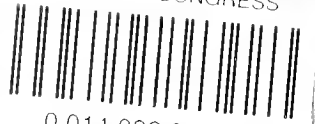

0 014 082 848 8

