

1590
S 87
1887



STONE'S

PARAMOUNT CUTTER

A System for Cutting Garments,

BASED UPON SCIENTIFIC PRINCIPLES, INCLUDING THE SELF-VARYING SHOULDER, IN CONNECTION WITH THE DIVISION OF THE BREAST-MEASURE.

By
Chas. J. Stone,
Chicago, Ill.

ILLUSTRATED BY TWELVE PLATES OF FINELY ENGRAVED DIAGRAMS AND ONE PROPORTION TABLE WITH FULL INSTRUCTIONS FOR DRAFTING THE VARIOUS STYLES OF GENTLEMEN'S GARMENTS.

CHICAGO:
PUBLISHED BY MEYER & BROTHER,
108 Washington St., S. E. Cor. Clark.

CH 10-2372

CH 10-27-17

— S T O N E ' S —



PARAMOUNT-CUTTER

A SYSTEM FOR CUTTING GARMENTS,

—BASED UPON—

Scientific Principles, including the self-varying Shoulder, in connection with the Division
of the Breast-Measure.

*

BY

CHAS. J. STONE,

CHICAGO, ILL.

*

Illustrated by Twelve Plates of Finely Engraved Diagrams, and One Proportion Table
with full Instructions for Drafting the various Styles
of Gentlemen's Garments.

*

CHICAGO:
PUBLISHED BY MEYER & BROTHER,
108 Washington Street,
S. E. COR. CLARK.

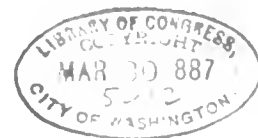

30
1-1

COPYRIGHTED BY
CHAS. J. STONE,

1887.

ALL RIGHTS RESERVED.

Ms. B. 5. 0. 1. 0. 3



Yours Truly
Chas. J. Stone

❖ P R E F A C E . ❖

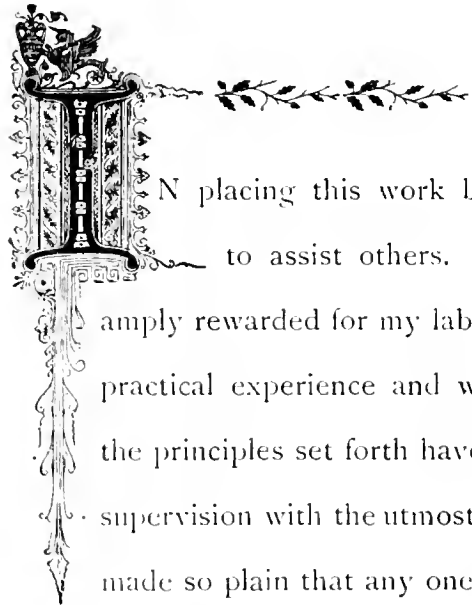
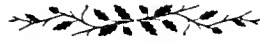

IN placing this work before the Tailoring fraternity I am actuated by a desire to assist others. Should I be successful in accomplishing this, I shall feel amply rewarded for my labor. The principles here laid down are the result of years of practical experience and with the most satisfactory results. The Diagrams illustrating the principles set forth have been drawn by myself and engraved under my personal supervision with the utmost care and are calculated to demonstrate accurate instructions, made so plain that any one who will give this system a careful study will find the entire work one of the most reliable on the subject that has ever been offered to the trade. While every page of this book is the result of my own reflection and the experience of many years at the Cutting Board, it is also proper to state that I have consulted with many of our Finest Artists, both in this country and Europe, in order that the present work might embrace the modern and most approved methods on Garment Cutting. The work commences with the production of properly fitting and correctly balanced garments for the normal figure. A master knowledge of the business is acquired by first qualifying ourselves in the knowledge of producing a *Fit* for a normal shape, and in the next place to change correctly from the regular to fit and conform to the various changes as we meet them in every day practice, this I clearly illustrate in my Self Varying Shoulder Measure.

In conclusion, let all those who intend to study and practice these new principles lay aside all prejudice and follow out the instructions as herein given, and in so doing, you will find that *complete success will follow* and you will become a hearty indorser of this valuable work.

THE AUTHOR.

BLOCK PATTERNS, AND WHAT ARE THEY GOOD FOR.



At the present age the Block Pattern is widely advertised as the only method of producing stylish looking and good fitting garments, but such is not the case. You will find no successful Cutter using Block Patterns, as he will produce his own Draft. It is only Cutters that have failed to produce a good fit, and in disgust over his failure he has caught the bait laid out for him and bought a set of Model Blocks, instead of learning how to produce them himself, and after going to the expense of getting them he is no better off than before. He does not know how to use them ; it is all guess work. The patterns are either too small or too large, too long or too short, and the results are no better than before. Now, understand me right. I am not adverse to the use of patterns, providing they are proportionate and the Cutter understands how to use them. But where will you find such patterns, as most of them are produced by inexperienced men that never cut a coat for a customer in their life, never held the position as Cutter and know no more about the science and art of cutting garments than a salesman or book-keeper in a tailoring establishment would. *How can such a man produce proportionate Block Patterns?* Nevertheless, they are the parties that are advocating the use of such patterns, and the more Cutters they can convert the more money it is in their own pocket. In my opinion it takes a practical Tailor and Cutter with many years of experience and hard study at the Cutting Board, where he has the opportunity of seeing his pattern on the customer in his daily practice. Such a man I consider to be capable of producing a Model Block. But where do you find such a man cutting patterns and putting them on the market for sale? Now in the next place, a poor Cutter does not know how to use them and a good Cutter has no use for them, as it takes more time to hunt up the Block, copy it on the Drafting paper and lay it aside again, than it takes to draft a pattern. I believe in a proportionate system, that I can lay down the proportion and then apply the measure for the disproportions. In this way I produce my own Blocks

and know what they contain, and need not rely on anybody's patterns. Besides, all this I can carry in my head and need not carry a trunk full of patterns and running the risk of having them destroyed by fire or any other accident, in which case I would be put at a disadvantage to cease cutting until I could secure another set of patterns, which would be a loss both to myself and to my employer. I believe in a Cutter being able to produce his own pattern instead of relying on others to do it for him. The principals laid down in the Paramount Cutter, as illustrated in Diagrams 2, 3 and 4, gives the true proportions, and in Diagrams 6 and 7 it shows you clearly how to alter for the disproportions, and in Diagram 13 (The Table of Proportions) I give all the measures that are in a proportionate pattern. In studying this work you will find that it comprises all the practical points that both the proportionate and the actual measurement systems contain.

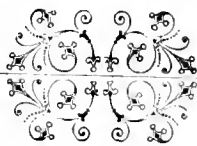

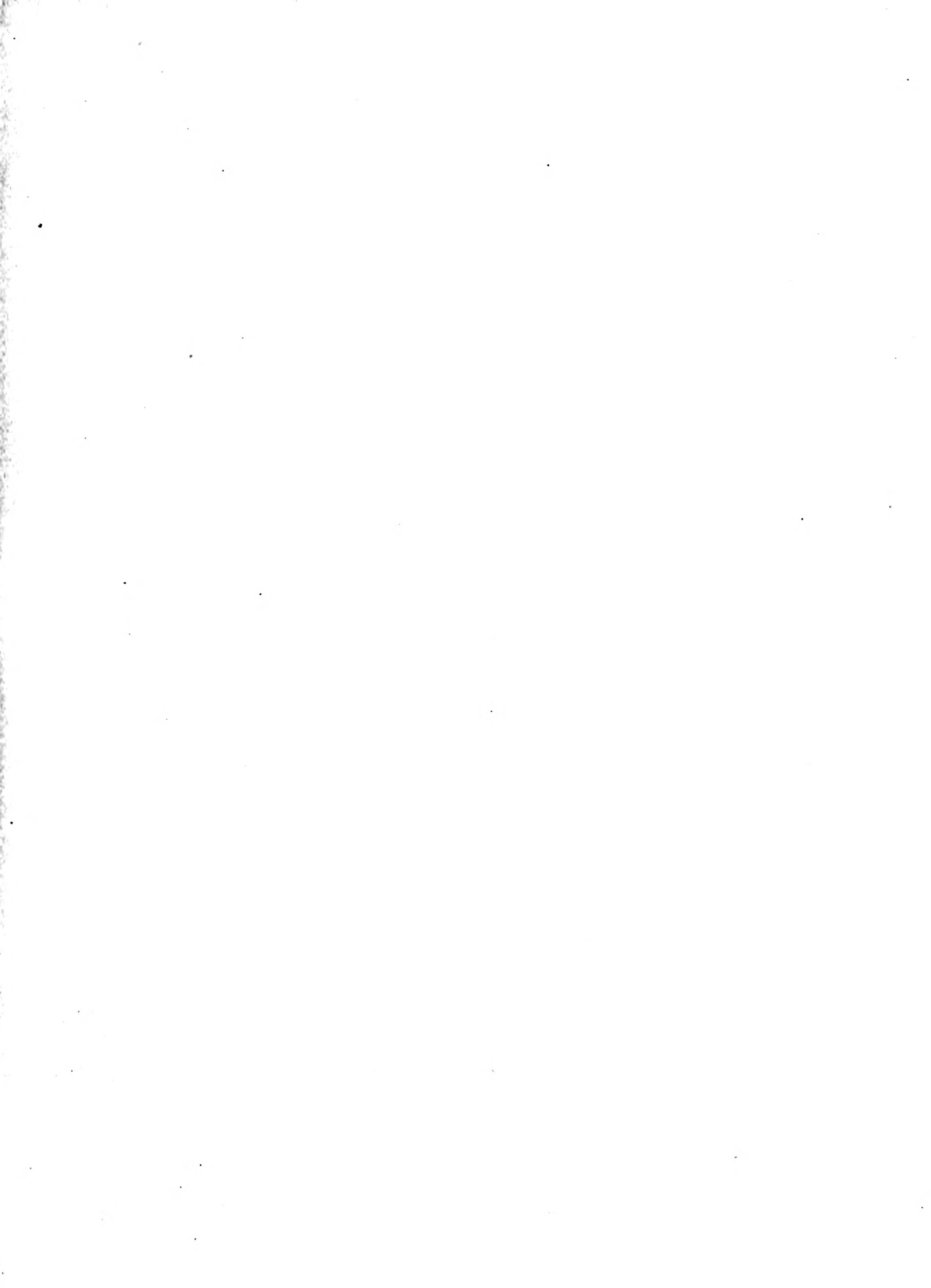

Diag. 1.

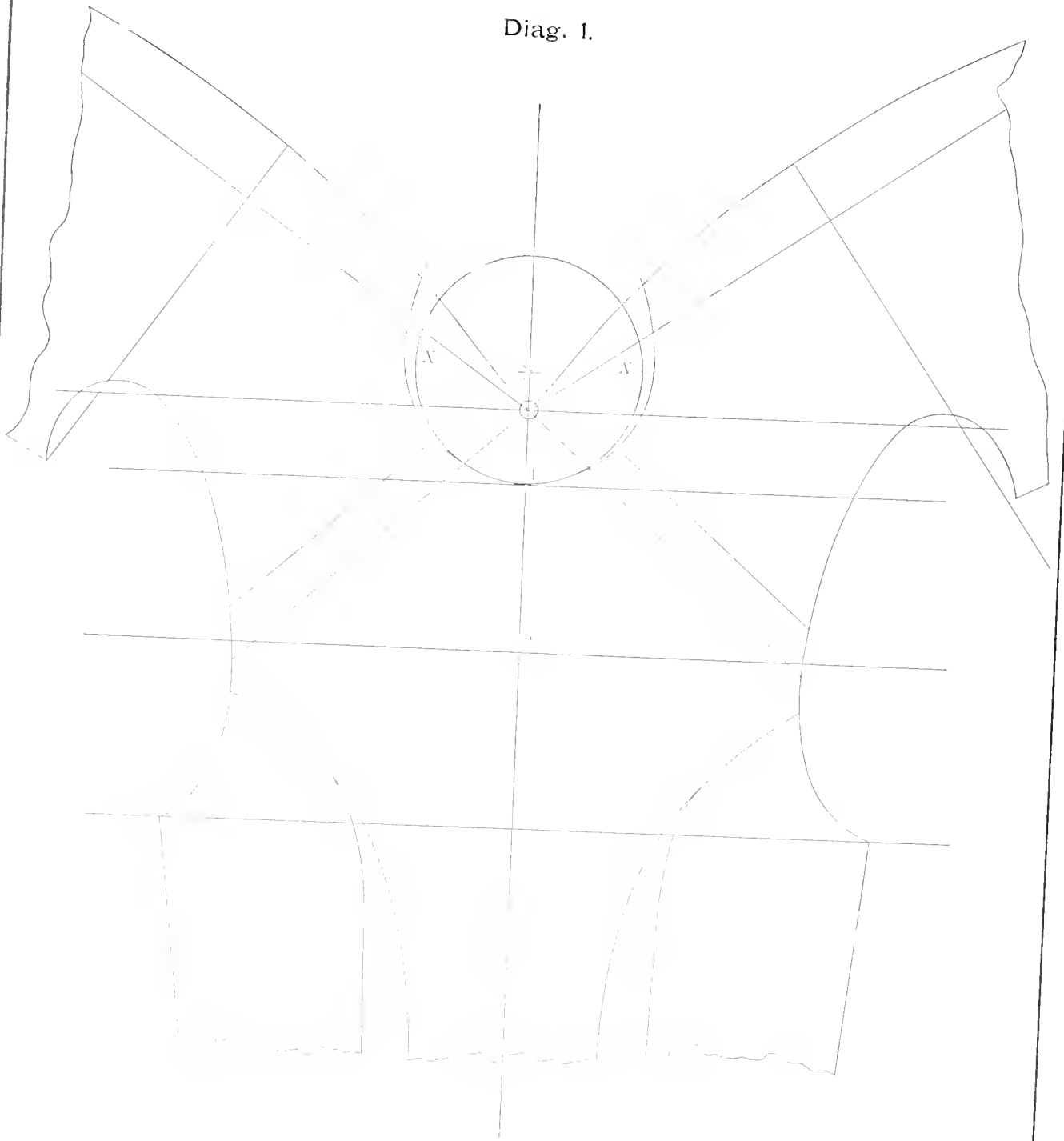

EXPLANATION OF DIAGRAM No. 1.

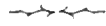

I now invite your careful attention to the principles which govern Coat Cutting. In order to make this as plain as possible I have designed Diagram 1, showing the Neck and Shoulder's and locating the Shoulder point. This point is looked upon by most cutters as the key to the whole Coat Cutting, and I must say that I never saw any system that located this point to any certainty. In my younger days I paid out hundreds of dollars to the most successful cutters for instructions on the shoulder point and they always gave it to me *about* right, but there was a good deal of guess work about it for different shapes and I never discovered the shoulder point until a few years ago, when in company with a young doctor friend of mine I tended a lecture (or clinic) on anatomy, and in the professor's lecture to the students on the human skeleton explaining every part of the body I concluded that I had at last found the shoulder point, and when I came home I put it into practice and found it to be correct. I will now explain this point. The round ring where all lines meet is the centre of the body, but as you will observe by looking at any well built man you will find that his head is not on the centre of the body, but one twenty-fourth of the breast forward, locating the centre of neck where the star is; the neck is one-third of breast, from x to x, making it a circle of one-sixth; from 1 to 2 is $\frac{1}{4}$ of breast, and from 1 to 3 is $\frac{1}{2}$ of breast. Now, as the neck gorge wants to follow the shirt collar it must be cut down in front as represented. This will clearly show you how to get the shoulder point and you can rely on it every time. The shoulder point will always be the same for all shapes, as a No. 15 collar will fit that size neck no matter what kind of a shoulder the man has, high or low. The neck gorge must be the same size from x to x, as a man's neck is. See Diagram 6 for long and short necks, and Diagram 7 for very erect and very stoop shoulder, regulated by the self-varying shoulder.

Diag. 2

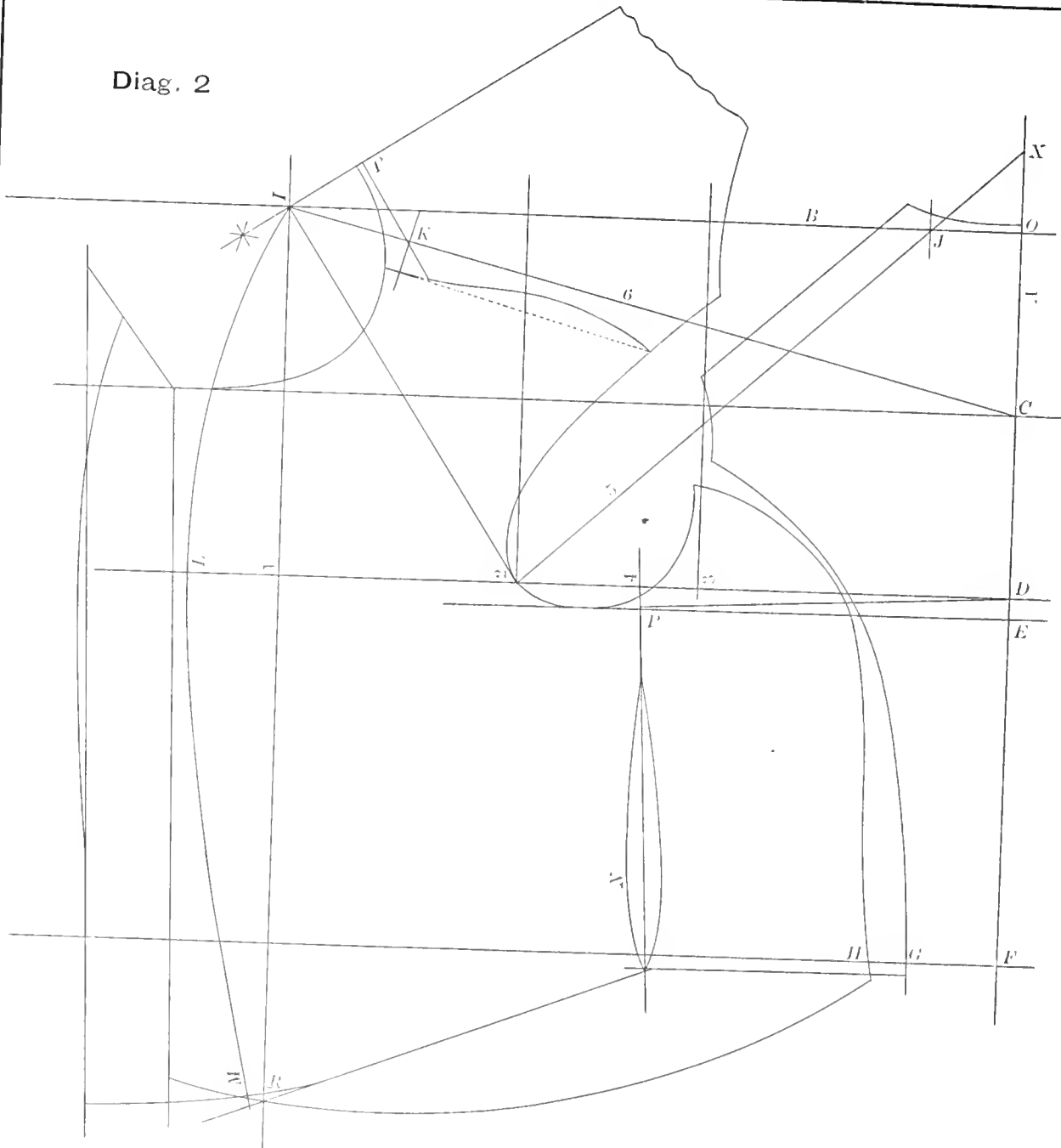

Diag. A

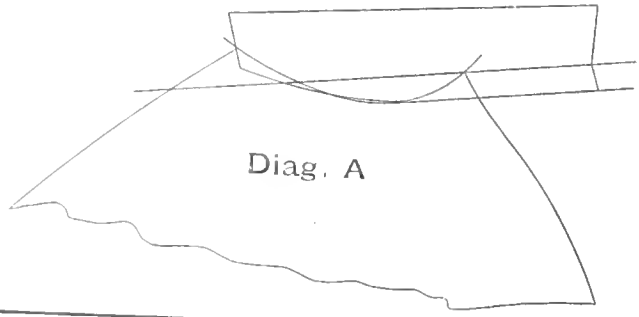

EXPLANATION OF DIAGRAM No. 2.



HOW TO DRAFT A FROCK COAT.

First square lines A and B, then from O to C is $\frac{1}{4}$, on the square on divisions of fourths From O to D is $\frac{1}{2}$, from D to E is $\frac{1}{2}$, square out lines C, D and E. From O to F is length of waist, from O to I is half of breast, square down the line at I. From 1 to 2 on breast line is $\frac{1}{3}$, from 2 to 3 is $\frac{1}{4}$, square up lines 2 and 3, from O to J is $\frac{1}{4}$. Draw slanting line from 2 through J, then draw slanting line from C to I. Shape top of back as represented, raising back at J $\frac{5}{8}$ of an inch; make width of back as represented making it the centre between lines 3 and 5 at line C, place shoulder seam on back wherever style calls for. From D to 4 is $\frac{1}{2}$; place corner of square at P slanting the arm up to D and square down for side body seam; make width of back from F to G $\frac{1}{4}$ of breast or whatever style calls for; from G to H is $\frac{1}{2}$, also take out $\frac{1}{2}$ between side body and fore part at N. Make side body one seam longer than the back at H; from 1 to K on slanting line 6 is $\frac{1}{6}$, from 1 to L is 2 inches; sweep from L to I by D, sweep from H to R by K, from R to M is $\frac{1}{2}$; draw front centre line from I through L to M, this will cut a front for a D. B. P. A. Frock. For a Cut-away Coat, or S. B. Albert add one inch extra, making it in all, over measure 3 inches. Now cut out back and place J on back, on point K on fore part, letting line 5 run parallel with line 6, so that point X and I will meet, then shape neck gorge as represented, then mark off back on shoulder like dotted line, then shape armseye as represented and add to rounding on shoulder over dotted line as shown, and cut shoulder $\frac{3}{8}$ of an inch smaller than the back, as the shoulder must be stretched that much. *How to cut the lappel is very easy.* Draw two straight lines and shape as represented, making the width whatever style calls for. *How to draft the collar is shown very plain in Diagram A below.* Anybody will understand it by looking at the Diagram.

REMARKS ON THE COAT DRAFT.

This Draft as laid down in Diag. 2, will cut a proportionate coat, or what is called a Block Pattern. The sizes from 32 to 40 being proportionate the points at N and at H G remain the same, add to the front whatever is needed for the waist measure, allowing 2 inches over the measure at breast, waist and hip. This will cut a Prince Albert front. For a Cut-away add 1 inch more, making it in all 3 inches over the breast measure. See Diagram 5 for the explanation on the waist measure.

REMARKS ON THE DRESS COAT.

Add to the front of a Dress Coat from 1 to L $1\frac{3}{4}$ inches, and at waist $1\frac{1}{2}$ over the measure, as the lappels only have to meet and button with a link button. At the second button from below; take out $\frac{1}{4}$ of an inch more at N, so as to make it close fitting at the waist. Make the lappel not over $1\frac{3}{8}$ inches wide at the waist seam, as it only wants to be wide enough to allow a button-hole to go in at this point.

P. S.—For other remarks on Dress Coat see general remarks on coats.

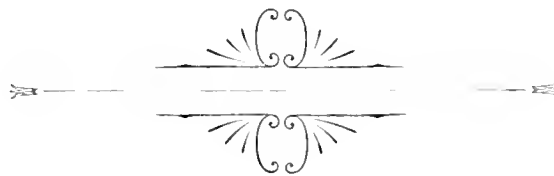

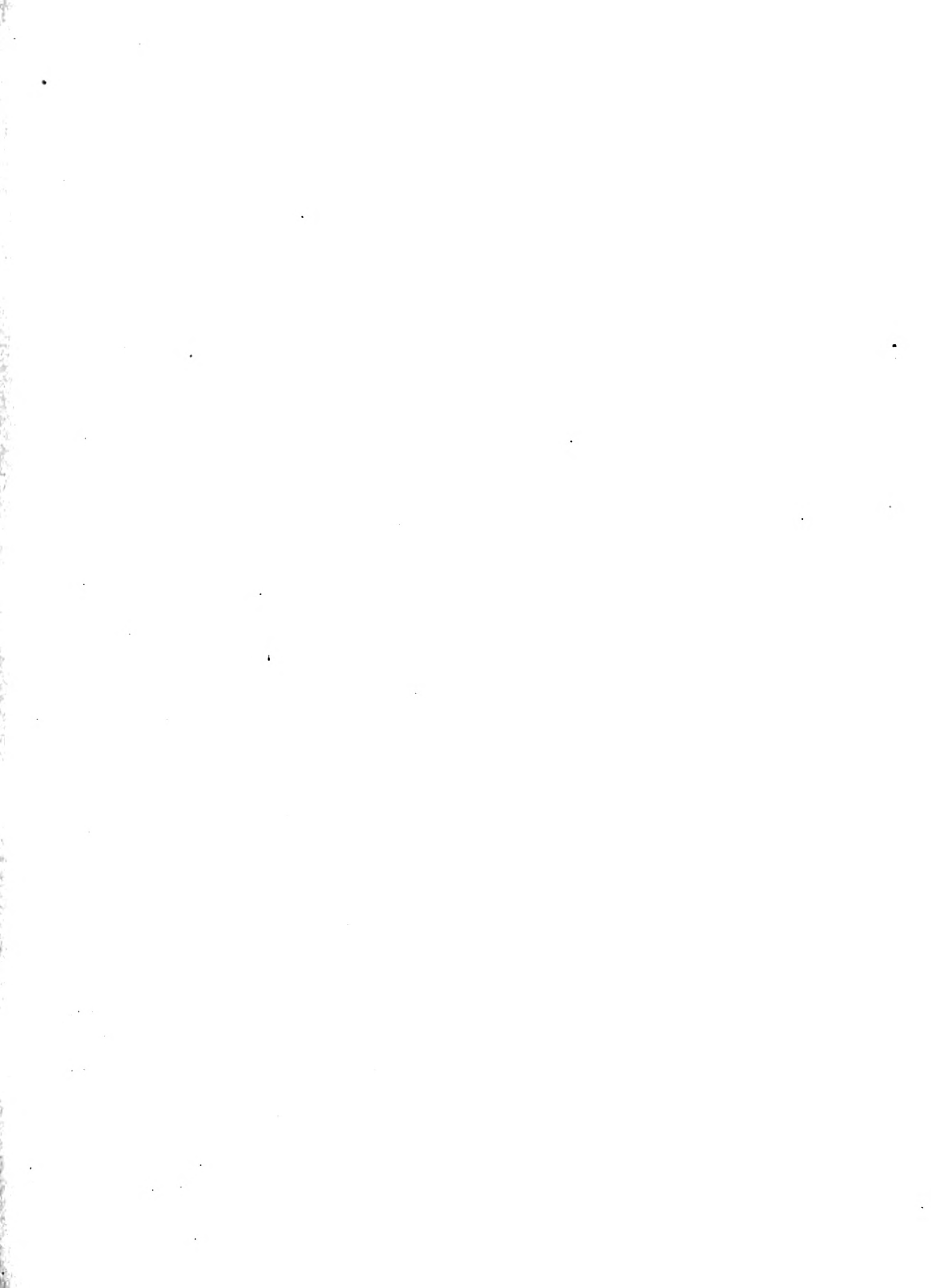

Diag. 3

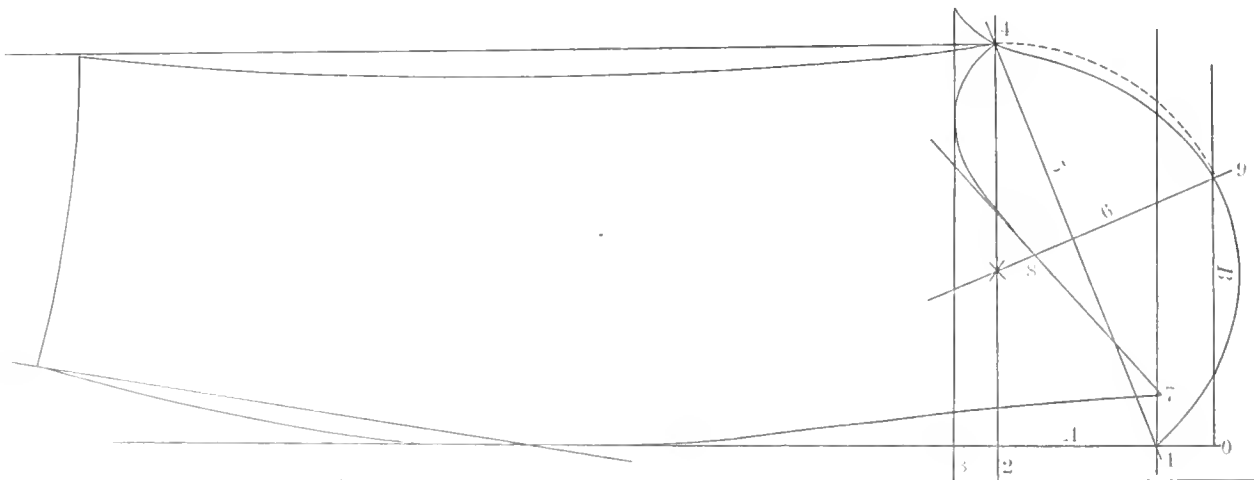
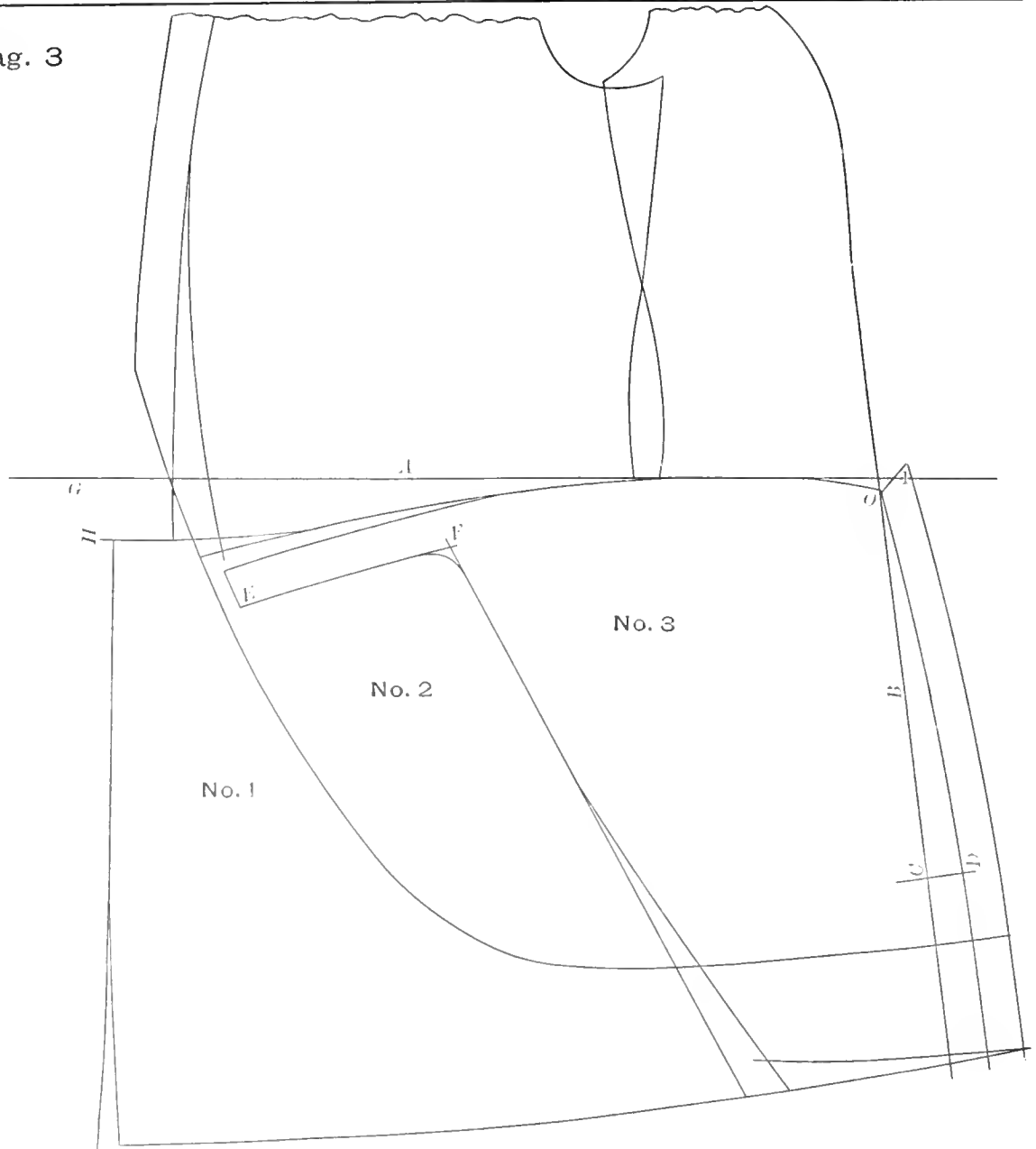

EXPLANATION OF DIAGRAM OF No. 3.

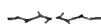

HOW TO CUT A SKIRT.

Draw straight line A, then place side body and forepart as shown in Diagram. Drop from G to H $\frac{1}{2}$ of the upper hip measure and shape top of skirt as shown in the Diagram, dropping down $\frac{1}{4}$ inch at O, then draw line B, by placing the straight-edge parallel with the side body from O to C is $\frac{1}{2}$ of the length of the waist of coat from C to D, is $\frac{1}{16}$ of the hip measure, this will give the correct spring to skirt, as if a man takes a large hip measure he requires a large spring, if a small hip measure he takes a small spring, etc.—for proportion the hip measure should be 1 inch more than the breast measure. No. 1 shows the style of a P. A. skirt. No. 2 shows the cut-away skirt, and No. 3 shows how to cut a dress coat skirt; the dress coat skirt must be cut down $\frac{1}{2}$ inch more at E, making it $\frac{1}{2}$ and $\frac{1}{4}$ inch from straight line A, to top of skirt at E, from E to F, is $\frac{1}{3}$ the distance from E to O. Make the width of the skirt at bottom $\frac{1}{3}$ or the same as from E to F; shape as shown in Diagram. Make skirt $\frac{1}{2}$ inch wider than the forepart for fullness over hip.

HOW TO CUT THE SLEEVE.

Square line A B from O to 1 is $\frac{1}{16}$, from O to 2 is $\frac{1}{4}$, from 2 to 3 is $\frac{1}{4}$; square lines 1, 2 and 3, then draw slanting line (5) from 1 to 4, making it $\frac{1}{2}$, line 6 is half way between 1 and 4, square line 6 up and down by line 5, 8 is half way between line 5 and the star, from 1 to 7, is $\frac{1}{16}$; draw a line from 7 through 8, sweep by star from 4 to 1; dotted line showing the sweep, then shape as represented, square down from 4, hollowing inside of sleeve to suit the shape of sleeve desired.

COMMENTS ON THE SLEEVE.

The distance from O to 3 must be the same as from C to E on the coat draft; make the distance from 1 to 4, one size less than the breast, taking $\frac{1}{2}$ on the division on 35 for a 36 coat, if an extra narrow sleeve be desired, reduce the distance from 1 to 4, 2 sizes, but never vary on the distance from O to 2 and 3 as that must in all cases be the same as the coat. When the sleeve is cut out, lay the under sleeve on the armscye and cut under sleeve the same shape as the bottom of the armscye. There can be no rule laid out for the inside seam of the sleeve as all the fine trade will place the inside seam in the centre of sleeve and cutting the sleeve quite crooked; where the medium and cheaper trade wants the sleeve cut straighter and the inside seam placed about one inch under the arm, so any cutter must use his own judgment in this matter.

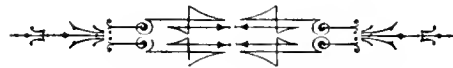

Diag. 4

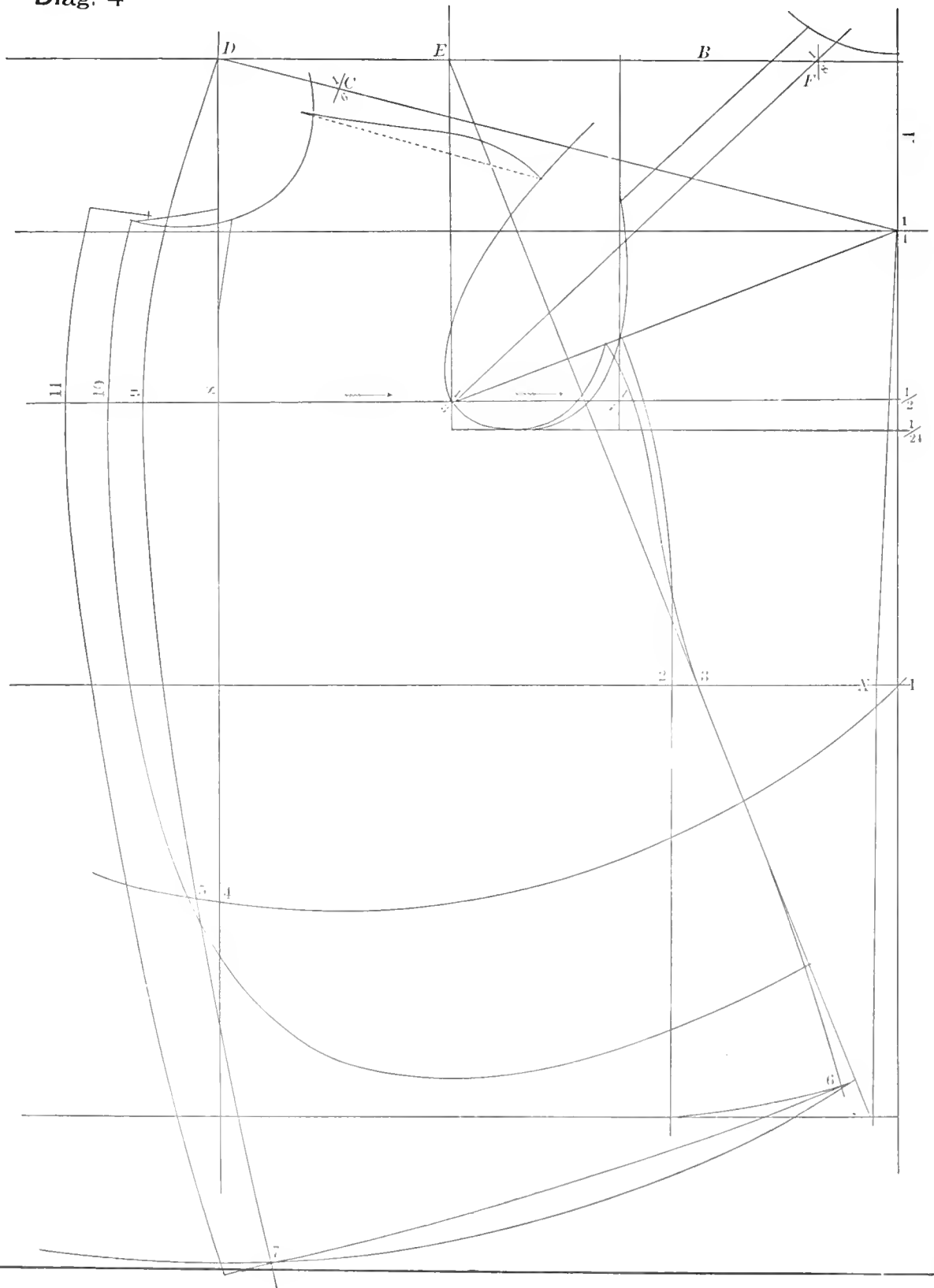

EXPLANATION OF DIAGRAM NO. 4.

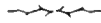

HOW TO DRAFT A SACK COAT.

The draft of the Sack Coat is very plain, the top part being the same as the Frock Coat. First square lines A and B, then go down $\frac{1}{4}$ — $\frac{1}{2}$ and $\frac{1}{4}$, square these lines then go forward $\frac{1}{2}$ of the breast measure and square down this line. From front line at 8 to front of armseye is $\frac{1}{3}$ of breast width of armseye is $\frac{1}{4}$. Draw up these two lines, then draw a line from D to centre of Back and one line from centre of back to front of armseye to F $\frac{1}{2}$ top of neck. Hollow centre of back at waist from 1 to X $\frac{1}{2}$ inch from 1 to 2 is $\frac{1}{4}$ of breast. Square down from 2 then shape back as shown in Diagram. From 2 to 3 is $\frac{1}{16}$ of the hip measure, E is $\frac{1}{3}$ of breast measure from D. Draw a line from E through 3, this will give the correct spring, sweep from 1 to 4, by C, from 4 to 5 is $\frac{1}{4}$ of Breast, then add at chest from 8 to 9 two inches. Draw line from D through 9 and 5 to 7, this will give the centre line. Now add for lap on a S. B Sack, one inch from 9 to 10, line 10 will make a straight front sack coat, corners rounded off. For an over coat add $2\frac{1}{2}$ inches from centre line 9 to 11; always get your centre line first, as that will just meet in front, then shape your front to any style desired, sweep from 6 to 7 by D for length of coat in front; Shape side seam as shown in Diagram, taking out $\frac{3}{4}$ of an inch at top of side seam, cut back out and place F $\frac{1}{4}$, on C $\frac{1}{4}$, on top of each other letting the 2 balance lines meet, then shape neck gorge and armseye as shown in Diagram, marking off back on shoulder like dotted line, then add $\frac{1}{2}$ inch over the rounding of shoulder, coming down to dotted line as shown in Diagram. This will cut a proportionate coat, or Block Pattern; for fat man, change in front as shown in Diagram 5, adding on to front and leaving the back remain as it is. For other changes see Diagrams 6, and 7, and the self varying shoulder measure.

To cut an over coat by the under coat measure add two sizes, as it takes a 38 overcoat to go over a 36 under coat.



Diag. 5

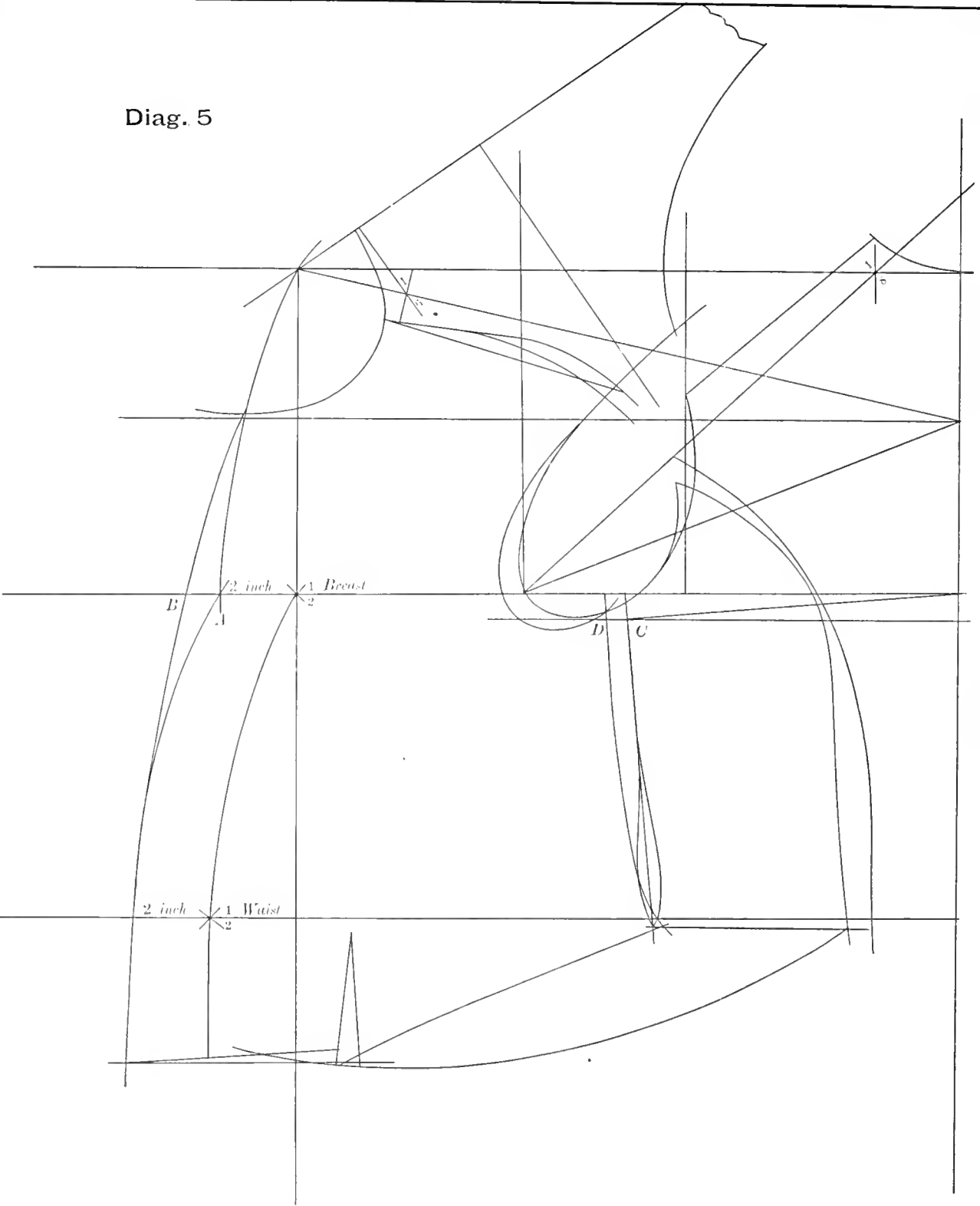

EXPLANATION OF DIAGRAM No. 5.



HOW TO CUT A COAT FOR A CORPULENT MAN.

Diagram 5 represents the fat man's coat, 44 breast and 46 waist, by adding two inches to breast and sweep up from A, then go out $\frac{1}{2}$ of waist measure and add two inches, then draw line down from A, this will make the chest hollow, and a coat front cannot be cut in this shape. So add all that is needed from A to B making a straight front line, then cut out under arm from D to C, the amount added to front less $\frac{1}{4}$ of an inch. Clear out front of armseye the same amount taken out under arm, also cut off lower shoulder point the same amount. This is the only way to cut a fat man's coat, and get it in proper shape. A sack coat is cut the same way, also the vest. There are very few cutters that can cut a fat man's coat, the reason being that they have an idea that the fat man is built like a lean man, only larger; but this is not the case, as the fat man will in most cases take a 40 back, in both length and breadth. And will require a 44 front, and measure 42 breast and waist. If you will follow my instructions in Diagrams 6 and 7, you will see my way of cutting the Corpulent Coat, by the aid of the self-varying shoulder measure.

HOW TO TAKE A MEASURE.

TO MEASURE FOR A COAT,

First determine the full length of waist, and full length of coat and mark with chalk, then start measuring, take upper shoulder measure from top of neck (socket bone) around under arm and up to the neck again; then take the lower shoulder measure from centre of back opposite sleeve seam around arm and back to same point; next measure length of waist and full length of coat, then measure the width of back, then length of sleeve from under arm to hand coming down on hand the length desired for sleeve; this, the sleeve length, must be taken with the square; next measure around the armscye and call off the width at hand desired, then measure around the breast, and around the waist, and around top part of hip, where the waist seam of frock coat will come, and around the most prominent part of hip. This completes the measure of all kinds of coats.

TO MEASURE FOR A VEST,

First take the length of roll from the socket bone to where the vest is intended to roll, then the full length of the vest, and the length from the socket bone to the hip, for the length of hip, then breast and waist measure. In cutting a single vest, you can take the shoulder measures same as on the coat. All these measures are taken medium close excepting the upper and lower shoulder measure, which is taken snug.

TO MEASURE FOR TROUSERS,

First take the length from waist band to knee and to bottom on the outside, then take the inside length, then the waist and then the most prominent part of hip, so thigh, knee, and bottom. In fat man's pants take an extra measure for the height of waist in front, also an extra measure around the upper part of hip between the waist and seat measure.

NOTES ON TAKING MEASURE.

It is well to bear in mind that in measuring a small lean man, to measure him quite loose, and in measuring a stout fleshy man, to measure him quite snug.

Diag. 6

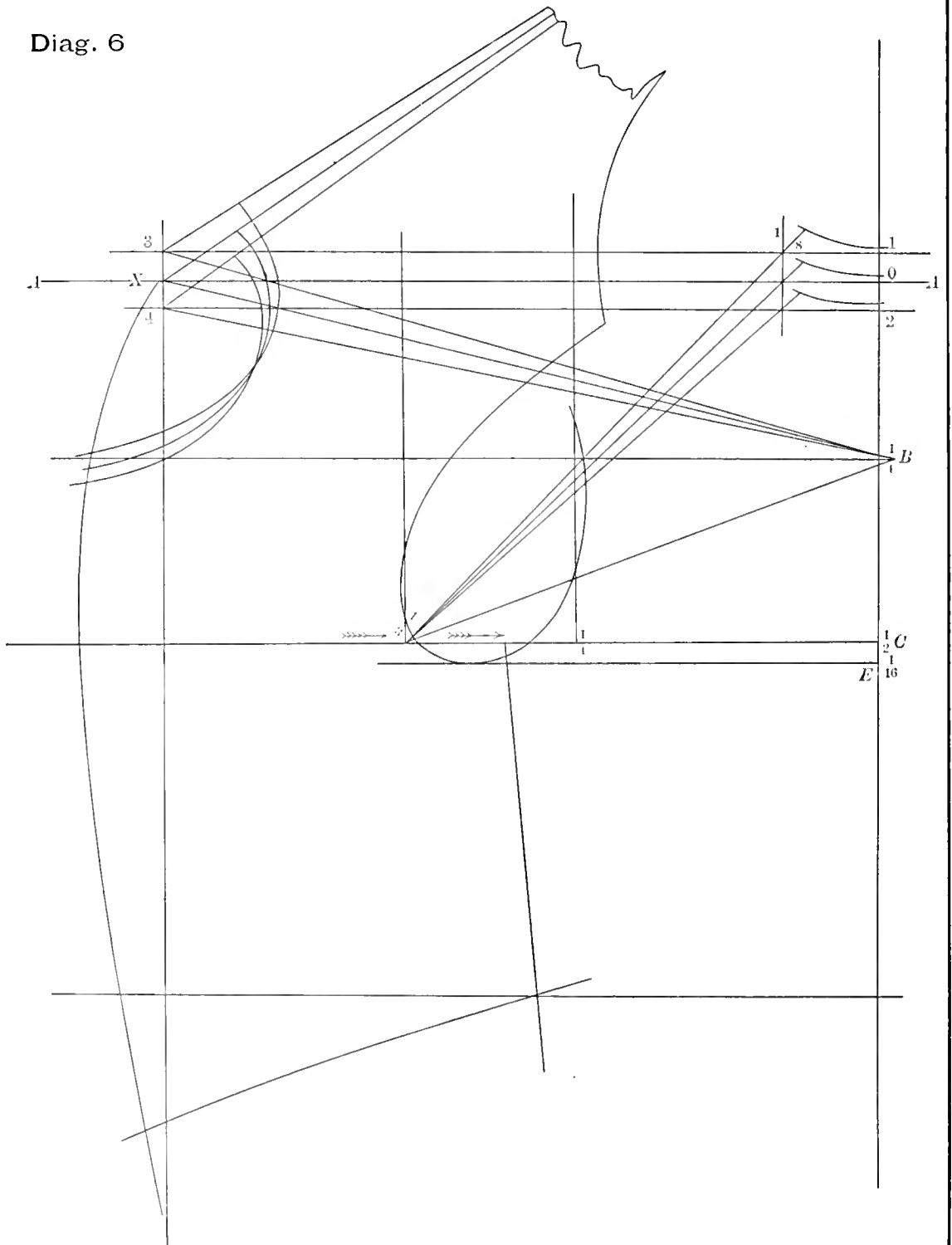

EXPLANATION OF DIAGRAM No. 6.



THE SELF-VARYING SHOULDER.

The upper shoulder measure is taken from socket bone at O, around under arm up to socket bone. This measure taken snug will be for a 36 coat, 26 inches, or 2 inches more than $\frac{2}{3}$ of the breast measure. Now this is proportion, and you must cut a proportional coat from O to B, C and E, but if the upper shoulder measure was 28 and the breast 36, you will have a man with long neck and will have to raise the back from O to 1, or making it the proportion $\frac{1}{2}$ of 39 from C to 1. But point B is $\frac{1}{4}$ of 36 from C. Drawing the top line across to front 3. Now understand me right, the distance from C to B is always the same, $\frac{1}{4}$ of breast measure, but the distance from B to A will be increased or decreased as the measure calls for. If you have a 24 upper shoulder, and 36 breast, you would have a man with a very short neck, and you would have to reduce the length of top of back to line 2. Making it the proportion of 33 breast from 2 to C, but from C to B is the proportion of 36. On line A, A and X is proportion line; 1 and 3 is high neck line; 2 and 4 is a short neck; the distance from line A to line E, is called the depth of armseye. By looking at Diagram 13, (the Table of Proportions,) it will tell you how to apply the upper shoulder measure. Find your upper shoulder measure on the Table of Proportions, then see what breast measure and what depth of armseye you have. It will also give you the length of shoulder strap. This measure taken carefully and applied as explained, will make the coat the right height in neck every time. Be very careful in taking this measure, and remember it is taken snug. This measure will make the coat higher or lower in the neck, but it will not make any more changes, so in order to find the size of the blade, we will have to look up the lower shoulder measure in Diagram 7.

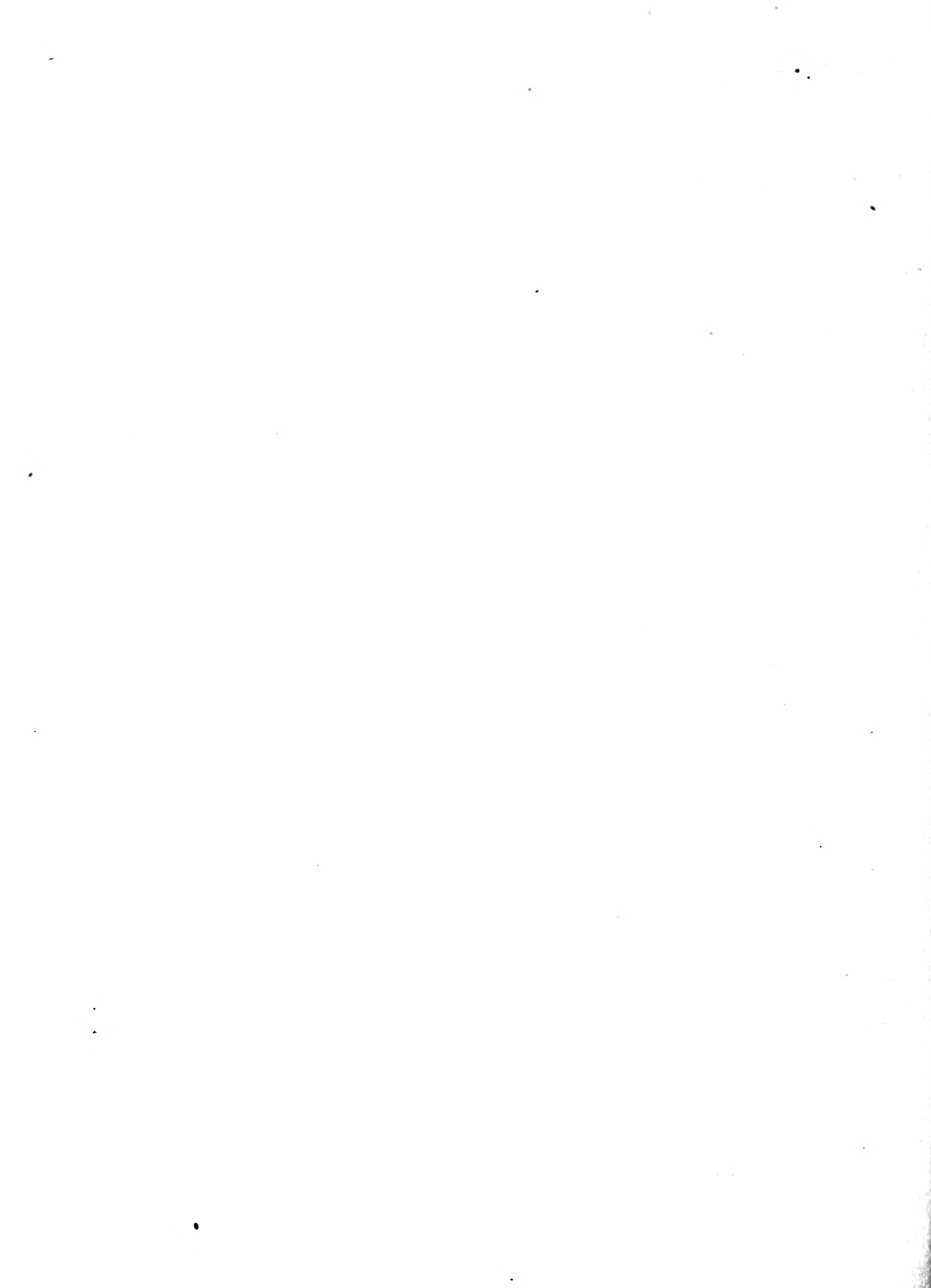

Diag. 7

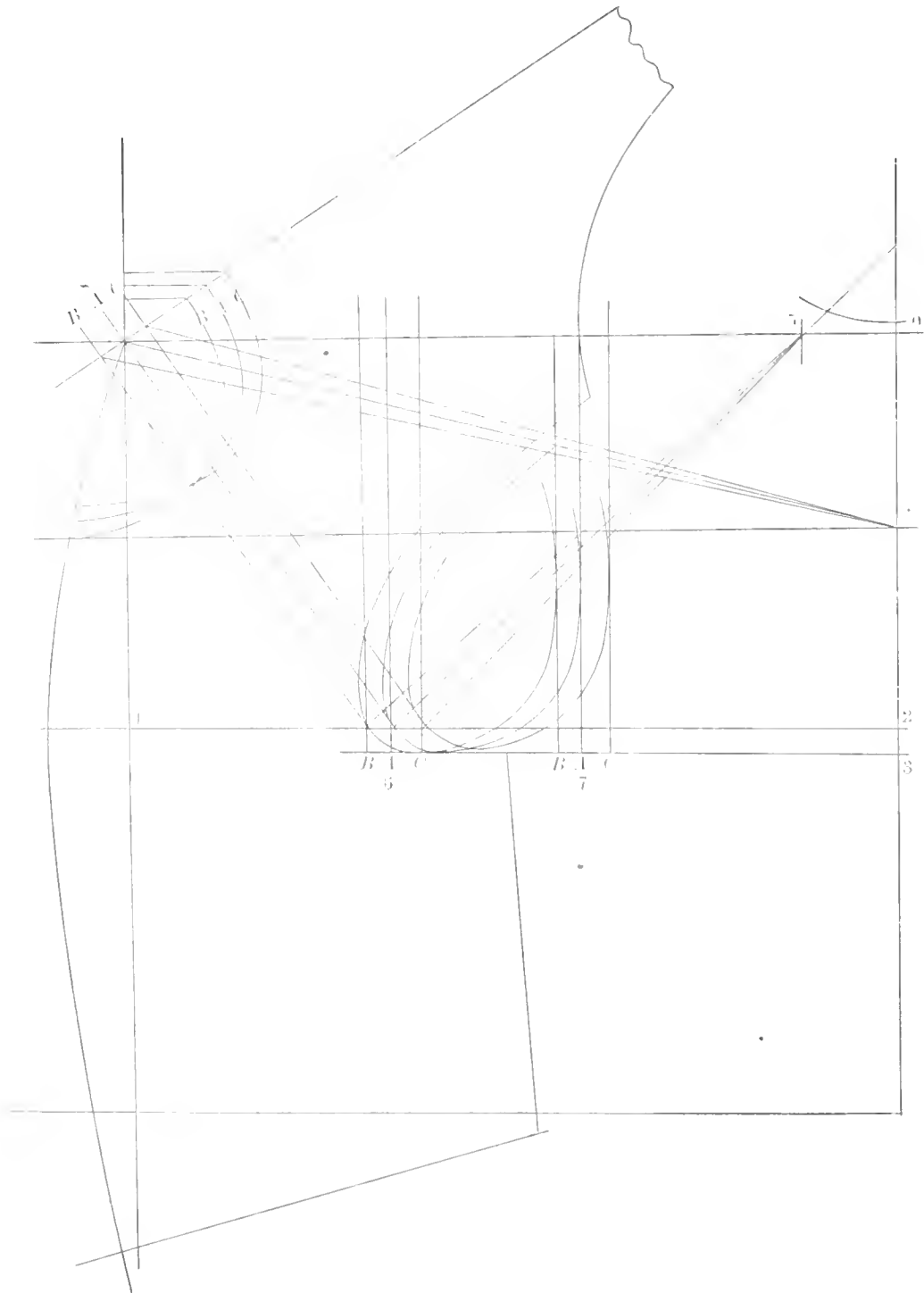

EXPLANATION OF DIAGRAM No. 7.

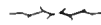

THE LOWER SHOULDER MEASURE.

The Lower Shoulder Measure is taken from centre of back, between the shoulder, or $\frac{1}{3}$ (of the Upper Shoulder Measure) down from O, around under arm and back to the same place. This measure will be one inch less than the Upper Shoulder Measure, and one inch more than $\frac{2}{3}$ of the breast; take a 25 Lower Shoulder Measure, deduct one inch, making it 24; half of 24 is 12, or $\frac{2}{3}$ of half of 36. Breast Measure, from 3 to 6 A is 12 inches, or $\frac{2}{3}$ of breast, or $\frac{1}{2}$ of lower shoulder, less $\frac{1}{2}$ inch. Now, if a man measure 27 lower shoulder, it shows that your man has a large blade, you will have to come forward to B 6, moving the armseye forward, also bring your shoulder point forward and shortening the front shoulder strap. Now, if you get a man that takes a 23 Lower Shoulder Measure, you will have to come back to line C, moving the armseye back and making the blade smaller, this will also move the shoulder points back to line C at 8. Place corner of square at corner A, 8, letting arm of square come down to point A, at 6, square lines both ways, this will give you the back line, then slide up and down on this line at 8, same as you do on breast line at 6, this clearly illustrates the Lower Shoulder Measure. A, is proportion, B shows a large blade, a straighter and shorter shoulder; C shows a small blade, a long shoulder strap and a crooked shoulder. See the proportion table for comparison of shoulder and breast measures.

PRACTICAL REMARKS ON COAT CUTTING.

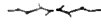

In cutting a fat man's coat, or a coat for a man that stands very erect, I have found the following measure very correct. 1st. Measure the length of shoulder strap from the socket bone to bottom of armseye in front, then go down $\frac{1}{3}$ of the upper shoulder measure on the back between the shoulders, or if this is too complicated go down $5\frac{3}{4}$ inches in all sizes, and measure from this point over shoulder to bottom of armseye, this will give a prove measure; if these two measures come out too long for the front strap, lower the armseye and move down the side body at P, in Diagram 2, say $\frac{1}{2}$ inch, in the most extreme case, then make forepart $\frac{1}{2}$ in waist, or enough to correspond with the length of the side body. If your measure should call for more than $\frac{1}{2}$ inch it is taken too loose, and in such a case the best thing to do is to stay by the system.

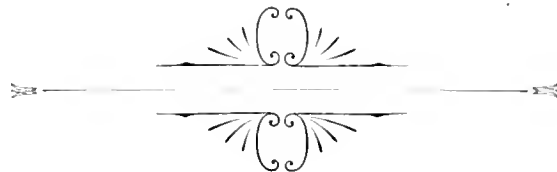

Diag. 8

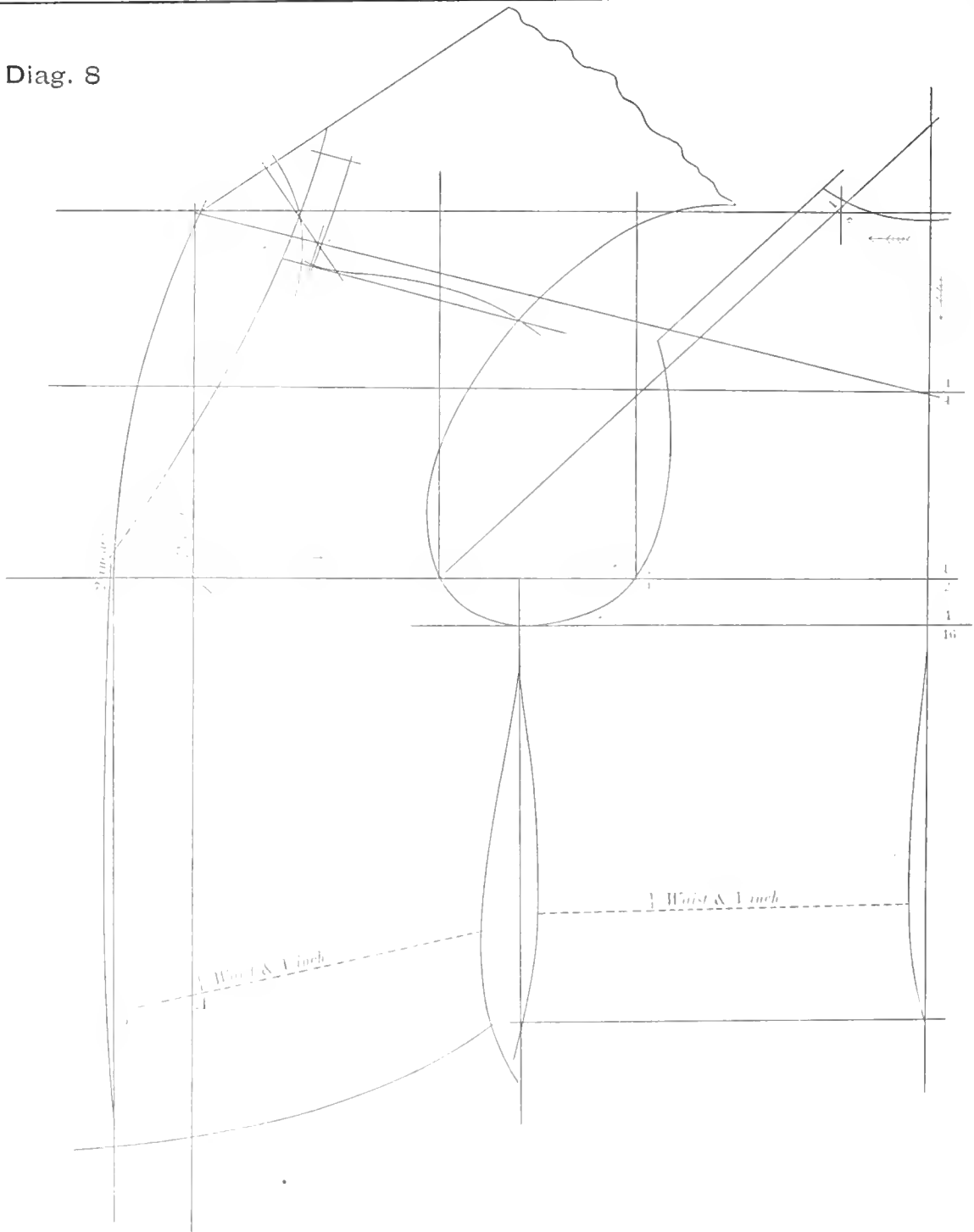

EXPLANATION OF DIAGRAM No. 8.

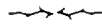

HOW TO CUT A VEST.

The vest is cut the same as the coat, only making the armseye larger. The divisions are marked on the draft. Cut the vest the same as the coat, adding to breast 2 inches, and draw square line down to B. This draft is laid down 36 breast and 34 waist, 2 inches more around the waist then what is called proportion. When waist measure is smaller, then 2 inches less than the breast measure, take off $\frac{1}{4}$ of an inch at B, for every inch that the waist is less than 2 inches of the breast, and add to front at B, $\frac{1}{4}$ of an inch for every inch that the waist gains on the breast. Take a man that measures 38 B, and 38 W, add $\frac{1}{2}$ inch to front at B. If 38 breast, and 40 waist, add 1 inch at B. Cut the front same as fat man's coat, adding on to hollow of chest, and take out under arm. Shape as represented in draft.

For a Double Breasted Vest, add to front $1\frac{1}{2}$ inch only, making centre line, then add all the lap you want. Use upper and lower shoulder measure on the vest, the same as on the coat. As all the points are laid out the same as in the coat draft, you will have no trouble in applying the shoulder measures on the vest, the same as on the coat: Cut the vest $\frac{3}{8}$ of an inch lower in the neck than the coat. In cutting a vest without a collar, add $\frac{1}{2}$ inch at neck of forepart, and for a vest with a collar, follow the back in shaping the neck, the same as on a coat.

PRACTICAL REMARKS ON VEST CUTTING.

Now in my practice I cut all vests, collar or no collar, the same as shown in the diagram. When I want a collar on the vest, I cut the silicia collar the shape that I want the collar to be, and sew it on to the edge of the vest, and not press the seam open. This will cut a better collar than the old style. As there is no seam to show through the collar when pressing the vest, however, this has nothing to do with the fit of the vest, I merely mention it as I find it an improvement on the old style.



Diag. 9

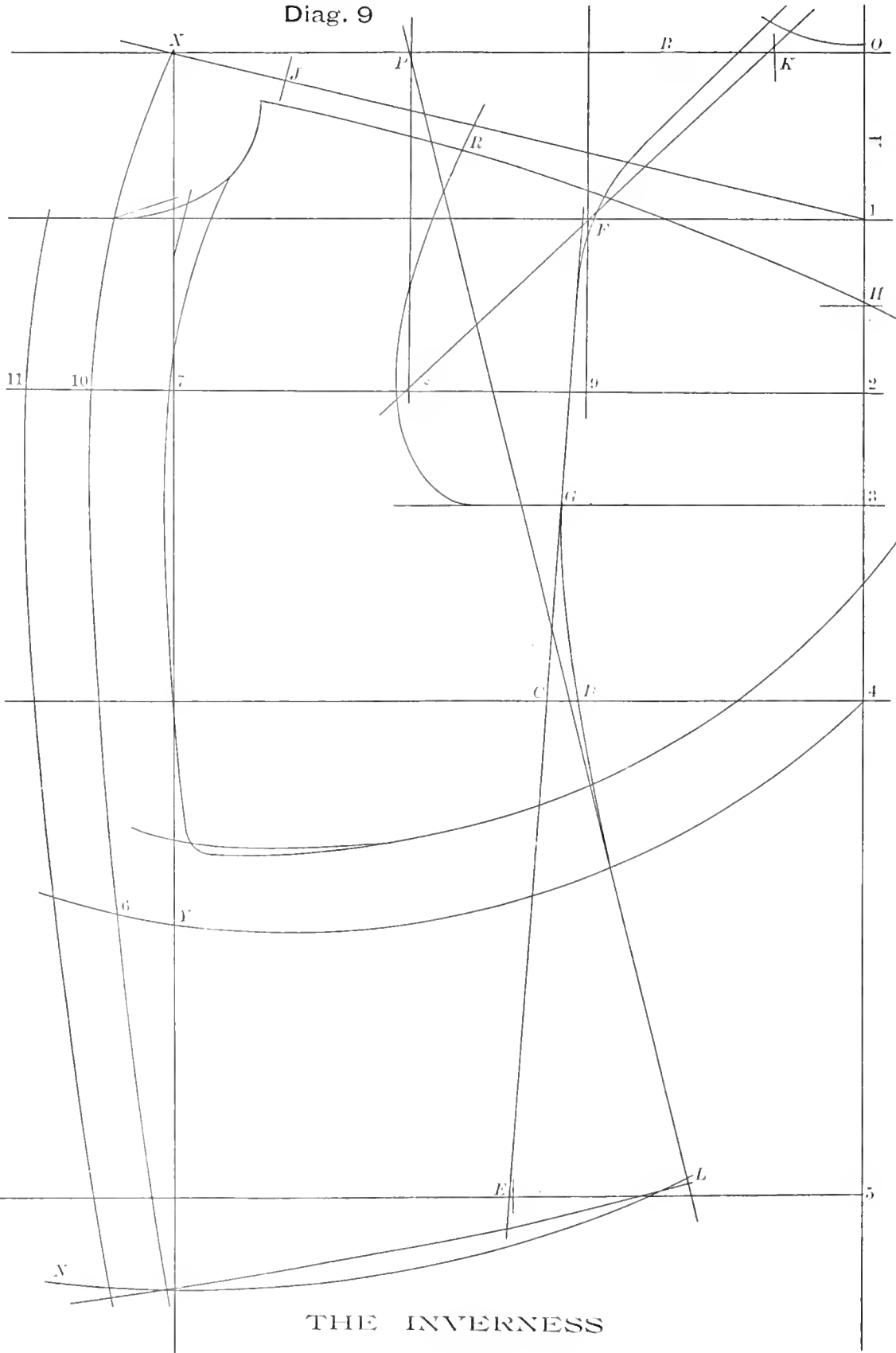

THE INVERNESS

EXPLANATION OF DIAGRAM No. 9.

THE INVERNESS, OR KING WILLIAM OVERCOAT.

This is an over-garment that very few cutters know how to cut; it is an over-garment mostly used as a Dress Overcoat, or in other words it is worn over the Dress Coat, as it slips off and on very easy without "mussing" the under coat.

It is cut almost the same as any other sack coat; first, square lines A and B, from 0 to 1 is $\frac{1}{4}$; from 0 to 2 is $\frac{1}{2}$; from 2 to 3 is $\frac{1}{6}$; from 0 to 4 is the natural length of waist; and to 5 is the full length. Square lines 1, 2, 3, 4 and 5; from 0 to X is $\frac{1}{2}$ of breast measure; square down this line, from 7 breast line to 8 is $\frac{1}{3}$; from 8 to 9 is $\frac{1}{4}$; square lines 8 and 9; from 0 to K is 18. Draw line from 8 to K, from 5 to E is $\frac{1}{2}$ of breast. Draw line from E to F and shape back as shown in diagram. Rounding the back at F, this completes the back. From C to D is $\frac{1}{6}$ of the hip measure. Draw line from P through D to L this will give the spring; shape from G to D as shown in Diagram; from X to J is $\frac{1}{6}$; sweep from 4 to Y by J; from Y to 6 is $\frac{1}{2}$ of breast measure, making it looser around the hip than the ordinary sack coat; from 7 to 10 is 2 inches. Draw front centre line from X through 10 and 6, then add from 10 to 11 $1\frac{3}{4}$ inches, or whatever lap is desired and shape front as shown in Diagram. Cut back out and place point K on J and finish shoulder the same as any other coat, only making the shoulder seam straight. Make width of shoulder one and one-half inch smaller than the ordinary coat shoulder is; shape arm-hole from R to line 3 at G, as shown in Diagram, and notch the back at G, make same distance from G to L as from G to E; sweep from L to N by X, for length of forepart in front; this will finish the Inverness. Next is the half cape, which is very plain. Drawing line from shoulder to H; H is $\frac{1}{8}$ from 1, or half-way between 1 and 2; sweep by J for length and finish as shown in Diagram. In some cases the cape is made to button same as the coat in front, in such a case add to cape in front making it 1 inch wider than centre line, 10 and 6. The collar is cut on this coat the same as any other coat.

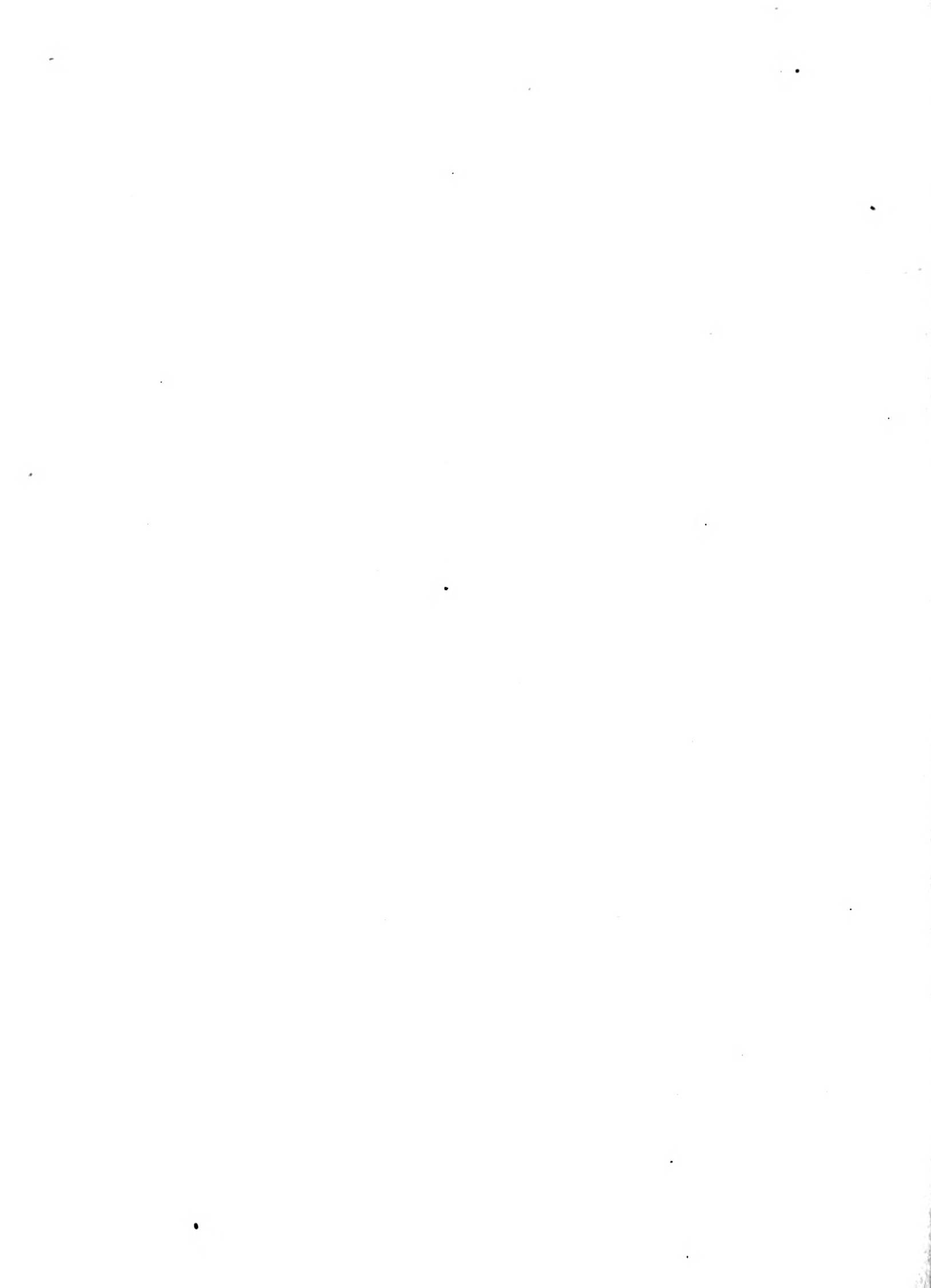

Diag. 10

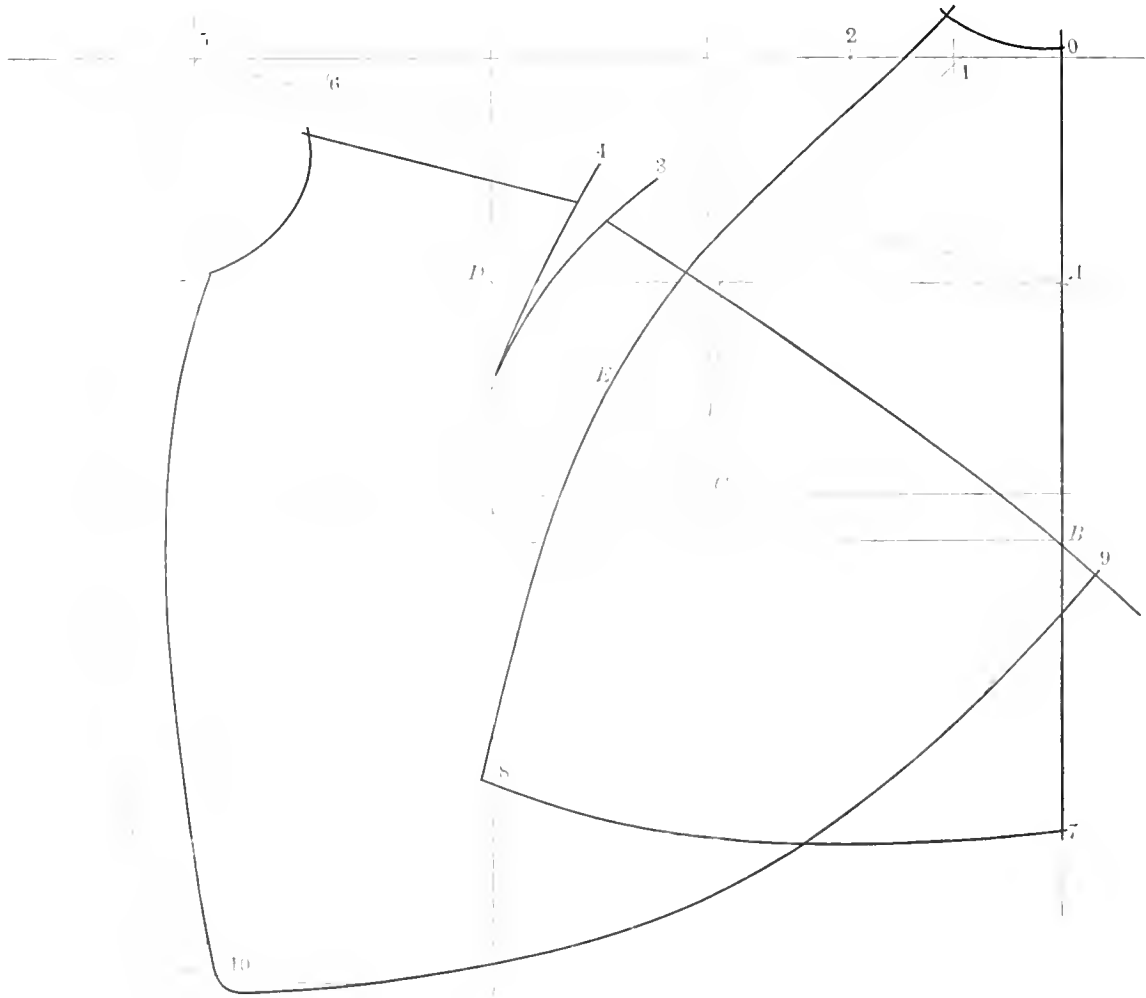

THE CAPE

EXPLANATION OF DIAGRAM No. 10.

~~~~~  
THE CAPE,

The shoulder cape, is at the present time worn quite extensive, over shoulders on the ordinary ulster coat, and made with a  $\frac{7}{8}$  of an inch band around the neck, with button holes, and buttons on the under collar of coat, so that it can be buttoned on and off at will. It can be cut from the overcoat pattern or from the ordinary coat draft, it being cut one size larger than the coat in order to make it large enough to go on the top of the coat. It must measure around, opposite the breast line,  $\frac{1}{3}$  more than the breast measure. Take for example a 37 coat, the cape wants to be 38, half of 38 is 19, being the half of breast;  $\frac{1}{3}$  of 19 is  $6\frac{1}{3}$  inches, add  $6\frac{1}{3}$  to 19 making it  $25\frac{1}{3}$ . This the cape must measure to go over the arms, the heavy lines showing the cape. To draft the cape draw first the coat draft, then draw a line from C to D, then shape back part as shown in Diagram, coming through point at E, down to 8, then get length of cape from 0 to 7 from 0 to star at 2, is  $\frac{1}{4}$  of breast; sweep from 7 to 8, by star at 2; from A to 3 is  $\frac{1}{2}$  of breast less  $\frac{1}{2}$  inch, and from 5 to 4 is  $\frac{1}{2}$  of breast less  $\frac{1}{2}$  inch. Cutting out from 3 to 4 as shown in diagram, from 0 to B is  $\frac{1}{2}$  and  $\frac{1}{4}$ , same as coat draft. Shape shoulder same as on the coat, coming down to 9, crossing line B, measure off same length on forepart to 9, as back is to 8, sweep from 9 to 10, by 5, and finish as represented and the cape is cut.

REMARKS ON THE CAPE.

In cutting the shoulder cape without the cut in shoulder, the back and forepart must be cut on halves, so if the entire width of the cape, opposite the breast line, is  $26\frac{1}{2}$  inches the back must be  $\frac{1}{2}$  or  $13\frac{1}{4}$  inches, and the front  $\frac{1}{2}$  or  $13\frac{1}{4}$  inches. Be very careful in getting the seam to run on the centre of the arm and shoulder, and have the seam sewed short over the rounding of the shoulder, by taking an easy measure over the arms, around the circumference of the body, just below the shoulder, and adding 2 inches to the measure for making up, and you will find it to come out right.





Diag. 11

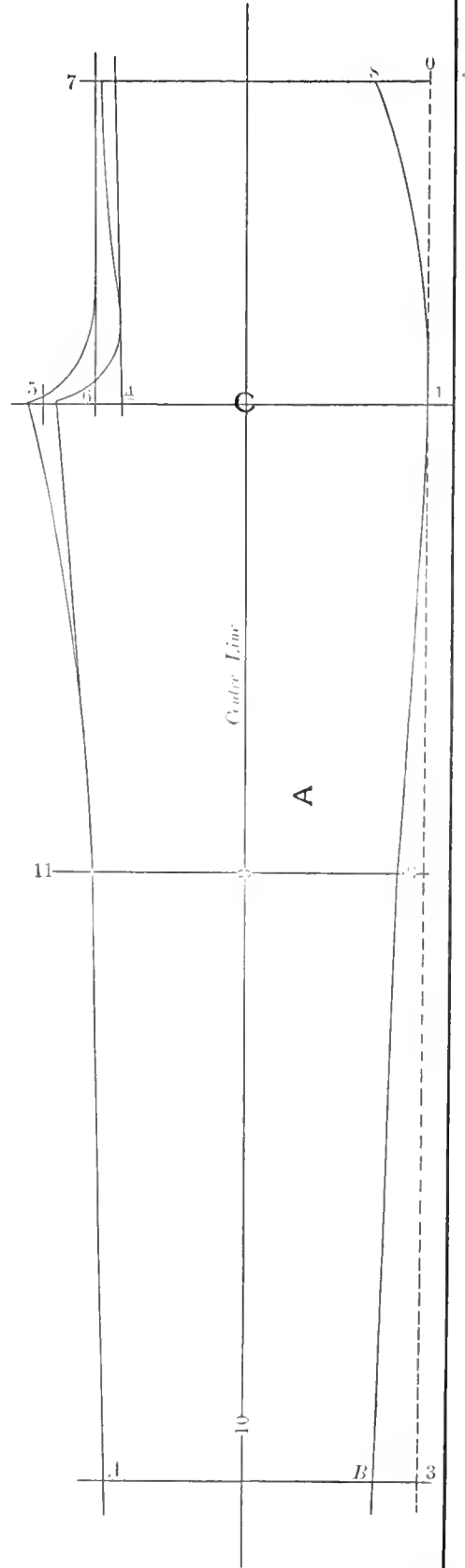
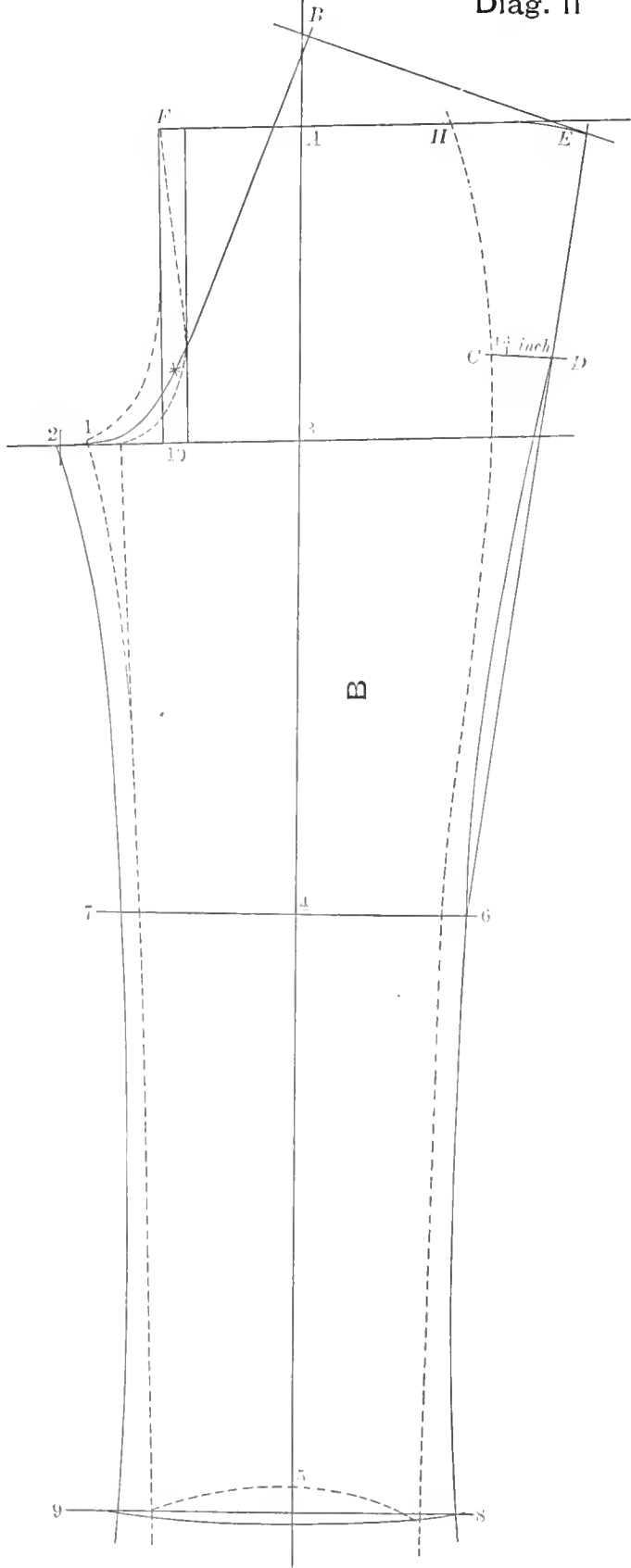

## EXPLANATION OF DIAGRAM No. 11.

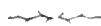

### HOW TO CUT TROUSERS.

The dotted line on Diagram A represents the edge of the paper, or goods if drafted on the cloth. First draw square line at o. Now I will draft by the following measures:

$$23-42-32-32-36-22\frac{1}{4}-18-17\frac{1}{2}.$$

From o to 2 is 23, and to 3 is 42, being the outside length; from 3 to 1 is 32, being the inside length. Square lines 1, 2 and 3; from 1 to 4 is  $\frac{1}{2}$ , (on divisions of halves on the square) of seat measure; from 4 to 5 is  $\frac{1}{8}$ , and from 4 to 6 is one-half inch. Draw lines 4 and 6; C is half-way between 1 and 5; go in the same distance from 3 to 10 as it is from 1 to C, and draw centre line, then get the width at knee, 18 inches, making the forepart 9 inches or  $\frac{1}{2}$  of knee measure, going out  $4\frac{1}{2}$  inches (or  $\frac{1}{4}$  on division of fourths on the square.) Each way from 9, make width at bottom from A to B 8 inches; for  $17\frac{1}{2}$  bottom, making it wide enough at bottom to give the forepart a uniform shape all the way down. Draw line from 1 to 2 and from 2 to B; then draw line from A to 11 and from 11 to 5, going in  $\frac{3}{8}$  at 5, then add  $\frac{3}{8}$  from 5 for the large side, making the dress  $\frac{3}{4}$  of an inch; from 7 to 8 is  $\frac{1}{4}$  of waist measure, or 16 on division of halves on square, shape as shown in Diagram, and cut out forepart; from 1 to 5 is  $\frac{1}{2}$  of thigh measure, this completes the forepart. Then for the backpart; place forepart on paper and draw lines 3, 4 and 5, also draw up centre line; from A to B is  $\frac{1}{6}$  of hip measure; from 10 to star is  $\frac{1}{8}$  of hip measure. Draw line from B to star; from 1 to 2 is  $\frac{1}{6}$  of hip measure, shape fork as shown in Diagram; add  $\frac{1}{2}$  inch at knee, from dotted line to 6, and  $\frac{1}{2}$  inch from dotted line to 7, allowing 1 inch over the measure at knee for seams. Then go out at bottom even each way to make up the measure, and one inch for seams; from C to D is  $13\frac{1}{4}$  inch. Draw line from 6 through D up to E, then measure from F to H and from B to E, making it  $\frac{1}{2}$  of the waist and 1 inch shape as shown in Diagram, and the pants are ready. Where a man is very small around waist and has a large hip a cut in the back part will be necessary in order to get the pants small enough around the waist.







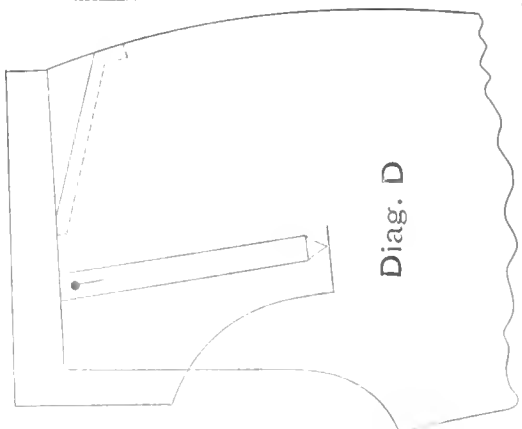
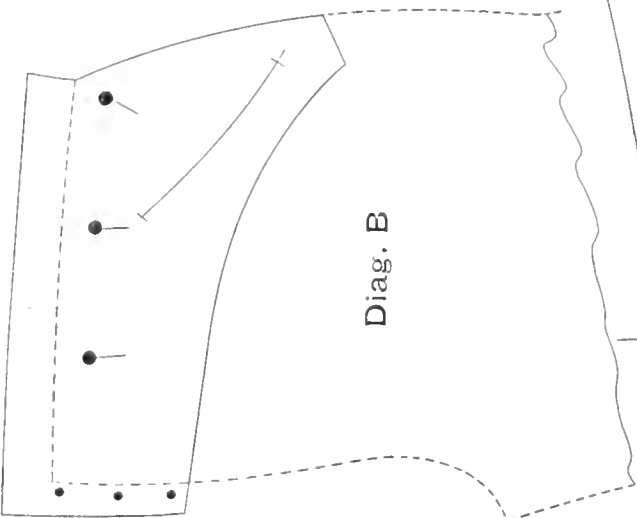
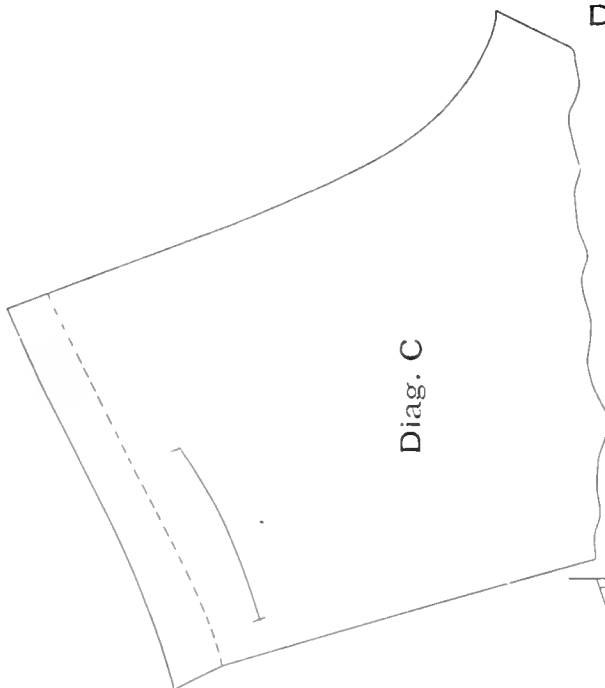

Diag. 12

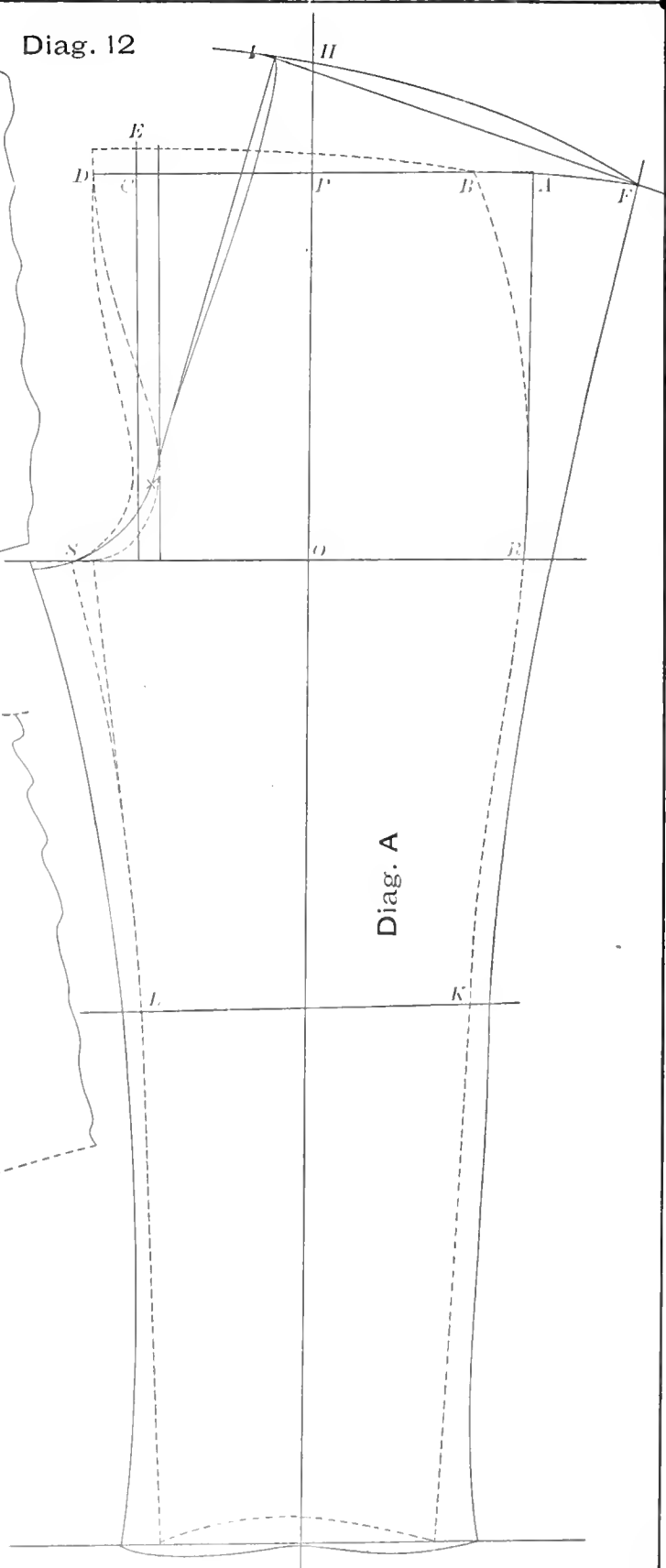

## EXPLANATION OF DIAGRAM OF No. 12.

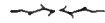

### THE FAT MAN'S TROUSERS.

The fat man's trousers are cut the same as any others below the seat, and adding more to the front at waist. Make same distance from B to P, as it is from P to C, then go out from B to D,  $\frac{1}{2}$  of waist measure, then take off  $\frac{1}{3}$  the distance from C to D, and add this to B, making the extra width,  $\frac{2}{3}$  in front and  $\frac{1}{3}$  in the side, then add from C to E,  $\frac{1}{2}$  the distance from C to D. Drop the fork  $\frac{1}{4}$  inch at S, add to back part from H to I, same as from C to D, then apply waist measure the same as in ordinary pants. From P to H is  $\frac{1}{6}$ , or sweep from F to H, by L, for height of waist behind.

Diagram B shows the Broad Fall pants, the dotted line being the forepart, and the solid line showing the fall bearer and where the pocket should be, if a side pocket is wanted place it in the side seam, same as any other pants. The amount of buttons in the broad fall, being all the way from 4 to 7, as the customer may want it. The fall bearer must be cut high enough to make up for the waist band. Diagram C, showing the backpart. The dotted line representing the stitching for the waist band, the opening of the broad fall in the side, must be  $\frac{2}{3}$  of the rise or from S to E on Diagram A.

Diagram D. This shows the old style of the Small Fall pants, the width of the fall is  $\frac{1}{6}$  of the waist measure, and the opening is  $\frac{3}{4}$  of the rise, finished with a band  $\frac{7}{8}$  of an inch wide and a triangle sewed out with silk in the end. In other respects they are made like the broad fall pants. This style of pants is not made very often, I have only cut a few riding pants this style.





== TABLE OF PROPORTIONS ==

| Breast Measure | Upper Shoulder   | Lower Shoulder   | Depth of Arm Scye | Length of Shoulder Strap |
|----------------|------------------|------------------|-------------------|--------------------------|
| 21             | 18               | 17               | 6 $\frac{1}{2}$   | 8                        |
| 25             | 18 $\frac{3}{4}$ | 17 $\frac{1}{2}$ | 6 $\frac{3}{4}$   | 8 $\frac{3}{4}$          |
| 26             | 19 $\frac{1}{2}$ | 18 $\frac{3}{4}$ | 7                 | 9 $\frac{1}{4}$          |
| 27             | 20               | 19               | 7 $\frac{1}{4}$   | 9                        |
| 28             | 20 $\frac{1}{2}$ | 19 $\frac{1}{2}$ | 7 $\frac{1}{2}$   | 9 $\frac{1}{2}$          |
| 29             | 21 $\frac{1}{2}$ | 20 $\frac{3}{4}$ | 7 $\frac{3}{4}$   | 9 $\frac{3}{4}$          |
| 30             | 22               | 21               | 8 $\frac{1}{2}$   | 10                       |
| 31             | 22 $\frac{1}{2}$ | 21 $\frac{1}{2}$ | 8 $\frac{1}{2}$   | 10 $\frac{3}{4}$         |
| 32             | 23 $\frac{3}{4}$ | 22 $\frac{3}{4}$ | 8 $\frac{3}{4}$   | 10 $\frac{3}{4}$         |
| 33             | 24               | 23               | 9                 | 11                       |
| 34             | 24 $\frac{1}{2}$ | 23 $\frac{1}{2}$ | 9 $\frac{1}{4}$   | 11 $\frac{1}{2}$         |
| 35             | 25 $\frac{1}{2}$ | 24 $\frac{1}{2}$ | 9 $\frac{1}{2}$   | 11 $\frac{1}{2}$         |
| 36             | 26               | 25               | 9 $\frac{3}{4}$   | 12                       |
| 37             | 26 $\frac{1}{2}$ | 25 $\frac{1}{2}$ | 10 $\frac{1}{4}$  | 12 $\frac{1}{2}$         |
| 38             | 27 $\frac{3}{4}$ | 26 $\frac{3}{4}$ | 10 $\frac{3}{4}$  | 12 $\frac{3}{4}$         |
| 39             | 28               | 27               | 10 $\frac{1}{2}$  | 13                       |
| 40             | 28 $\frac{1}{2}$ | 27 $\frac{1}{2}$ | 10 $\frac{3}{4}$  | 13 $\frac{1}{2}$         |
| 41             | 29 $\frac{3}{4}$ | 28 $\frac{3}{4}$ | 11 $\frac{1}{4}$  | 13 $\frac{1}{2}$         |
| 42             | 30               | 29               | 11 $\frac{1}{2}$  | 14                       |
| 43             | 30 $\frac{1}{2}$ | 29 $\frac{1}{2}$ | 11 $\frac{1}{2}$  | 14 $\frac{1}{2}$         |
| 44             | 31 $\frac{3}{4}$ | 30 $\frac{3}{4}$ | 11 $\frac{3}{4}$  | 14 $\frac{3}{4}$         |
| 45             | 32               | 31               | 12 $\frac{1}{4}$  | 15                       |
| 46             | 32 $\frac{1}{2}$ | 31 $\frac{1}{2}$ | 12 $\frac{1}{2}$  | 15 $\frac{1}{2}$         |
| 47             | 33 $\frac{1}{2}$ | 32 $\frac{1}{2}$ | 12 $\frac{3}{4}$  | 15 $\frac{3}{4}$         |
| 48             | 34               | 33               | 13                | 16                       |

From 32 to 40 is Proportion

From 24 to 31  
the Shoulder Measure will be  
less than Proportion

From 41 to 48  
the Shoulder Measure will be  
less than Proportion

## EXPLANATION OF DIAGRAM No. 13.



### THE TABLE OF PROPORTION.

This will give the proportion of all sizes, 36 being the true proportion, and running 4 sizes each way from 36. The shoulder measures will run shorter in most cases after coming past 40, showing that the depth of armscye must be less than proportion, the back not increasing in size as much as the front does. It is a daily occurrence to measure a man 31 upper and 30½ lower shoulder measure and 45 breast. Now find 31 upper shoulder and you will find it to be the proportion of 43½, making the depth of armscye 1158, and length of shoulder strap 1478. The smaller sizes below 31 are very much like the fat man's and should be cut on the same principle.



## NOTES ON MAKING GARMENTS.

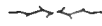

I will first state that I am a practical Journeyman Tailor as well as a Cutter. My father being a tailor I was born and raised in a tailor-shop, and I pride myself of having been one of Mr. E. Ely's best coat makers when only a mere boy, and I have the work book yet showing where I have made as high as \$45.00 per week making coats; so when I speak of coat-making I take it from real practice and not from guesswork. No matter how good a garment is cut it will not fit unless made up properly.

### HOW TO MAKE A COAT.

According to the present style of cutting there need not be so much stretching done as formerly. Stretch the shoulder across about  $\frac{3}{8}$  to  $\frac{5}{8}$  of an inch according to shape of customer, the armseye to be stretched in front about  $\frac{3}{8}$  only, the side body should be stretched a trifle at the hollow of the waist to give the coat a natural curve at the waist. The amount of side body to be stretched cannot be to any given rule, as the cloth has something to do with it. Extra care should be taken in stretching soft goods, as the coat is very apt to get too long in the waist behind. It is always well to give the coat maker warning not to get the coat too long in the back; it is also a good thing to give the length of the waist to the coat maker. The armseye from the back arm-seam of the sleeve around the blade to the centre under the arm should be held in a trifle by putting in a linen thread or a stay tape. The blade at this portion of the body is rounded and the holding in of the back part of armseye conforms to the natural shape of the body, preventing the coat from drawing or wrinkling at the top of the side body when the arm is in motion. The under sleeve should be put in a trifle full over the side body, and the seam should not be pressed open over the side body, this will allow the sleeve to fall gracefully over the side body and give it length enough when the arm is thrown forward. The collar should be put on easy, as a short collar will spoil the fit of the coat. The first thing to do when a coat don't fit is to look after your collar, and if short take it off before altering the coat elsewhere. The skirt should be put on from  $\frac{1}{2}$  to  $\frac{3}{4}$  of an inch full to the forepart over the hip. In a P. A. Frock or



Dress Coat. The lappel should be sewed on even below the roll, as a short lappel will make a bad looking front. There should be a great deal of care taken in basting under the canvas. A good many tailors has the idea that the canvas should be tight in the breast of the coat, this is a very bad practice as it will never make a good front. The canvas must be fully as large as the goods to make a good shaped front; press your canvas in good shape before basting under. In padding your breast do so from the lining side and use fine cotton and take short stitches on the side that goes next to the goods and do not draw the stitches tight as it will draw up the canvas and show through the broadcloth and dress worsteds. The stay tape should be put on fair, never draw it in very much as a short front edge is just as bad as a long one; if raw edge stitch close up to the stay tape; if bound there is no need of having any stay in the edges as it only makes them heavy and clumsy looking. There should be more care taken in basting on the facing on all coats than the tailors usually do. The facing should not be held on too full as it will not stand press but come back when exposed to the damp air. In overcoats the facing is very apt to get too short as the front edge has been held in with the stay tape. There should be a plait laid on the forepart lining at the waist seam, also in the centre of back and on the skirt lining over the hips. The neck pad should be put on easy. It would make a book of 300 pages if I was to describe all the points in coat making, so I will only give a few hints in pressing.

#### HOW TO PRESS A COAT.

The old style of hard pressing a coat before sponging the gloss off is a mistake, as it will take a good deal more steam to get the gloss off after allowing the garment to get cold, therefore, hard press with a fairly hot iron and immediately follow with the sponge cloth and a red hot iron, and you will not only have an elegant pressed coat, but will do the pressing in half the time. The light weight goods and German cloths will stand very little sponging, they must be dry pressed. I must here explain why this mode of pressing is superior to the old style. Take for example the canvas breast, and sponge hard on it, and you will find that it all puckers up, but if you hard press it first, and then sponge it, you will have sufficient heat in the canvas to dry up the steam, and the canvas will not pucker.

#### HOW TO DRY PRESS.

Take a piece of broad cloth and a piece of linen Holland and sew the two together, lay the cloth side to the garment you press; wet the linen with a sponge and press dry, and you will have your garment dry pressed without getting it glossed. Farmer satin or other smooth faced goods, will take the place of broadcloth, but the cloth is the best.

#### VEST MAKING.

On the subject of vest making there is not much to be said. So far as the putting the vest together, it is easy to learn; in joining it up in the sides, be sure and have the back and foreparts even at top under arm, also even at the neck, in putting the shoulders together, the back should go on easy to the forepart. A good vest maker is one that is very neat and tasty, with some artistic skill in forming a good shape in the collar, breast and shoulder. The front edge should be held in very little.

#### HOW TO MAKE TROUSERS.

It does not require an extra fine sewer to be a good pantaloon maker, but he should have some artistic skill in shaping the legs, the pantaloons require no stretching before sewing them up; put them together as they are notched and then press them in shape, never glue the bottoms with rubber tissue, as it will spoil the bottom after one weeks wear, and you will have trouble with them. In very light weight goods, a strip of canvas cut on the bias should be put under the turn-up at bottom; in joining the pants up, the seam should be stretched about  $\frac{1}{2}$  inch on the back part in fork, to make the pants easy in stride.

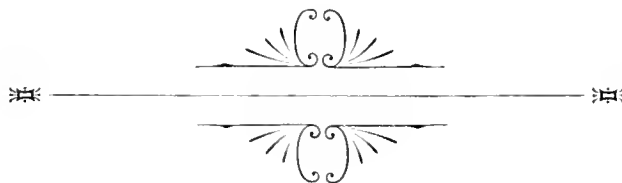

## ADVICE TO YOUNG CUTTERS.

Young cutters should not allow themselves to become involved in the mechanical repetition of producing and reproducing the same thing from day to day. The art of cutting is nothing more nor less than to please the customer, and in so doing, your employer is also pleased, and you will have the reputation of being a good cutter. The position as a cutter, naturally brings one in contact with all classes of people, and a cutter never should allow himself to argue with a customer on any subject. It requires lots of attention from the cutter to the customer, as most customers have a weakness for attention, and if attended to in a genteel and polite manner, (not dudish or foppish), the customer will have less fault to find with the fit of the clothes, as well as the price paid for them. There is nothing to be lost by being civil and polite to everybody, but everything to be gained, even though you do not care for the customers trade. When a boy, I heard a remark from a tailor to a customer who was abusing him most shamefully about a coat, the customer finally asked the tailor, "Why don't you get mad? I think I have insulted you enough." The tailor answered, "No, you have not insulted me." "Well, how is that?" the customer remarked. "Well, you see, Mr. Brown," the tailor replied, "A gentleman would not insult me, and one that is not a gentleman cannot, as I take no notice of him." Now, whenever a customer has acted ugly, I have always remembered this remark, and it has done me lots of good. To be a successful cutter, one must study human nature; study etiquette and how to be graceful, never allow yourself to get excited; never allow yourself to insult anybody in your business, and don't allow anybody to scare you by telling you that they have got "a h—l of a fit;" it may not be half as bad as the customer makes it. A cutter should avoid the use of tobacco in all its forms, never smoke in the store, and avoid intoxicating beverages, hold your breath when in front of a customer, he don't like the smell of whisky, onions, limburger cheese, etc., he may be very fond of all these things himself, but he don't like the smell of it from anyone else. A cutter is considered an artist, and is a gentleman, and if you don't think anything of yourself, how can you expect anybody else to think anything of you. So a successful cutter must be a gentleman in every respect, as well as being a good cutter. The two combined makes an A 1 cutter and such a man can always secure a good position and good pay.



# PRICE LIST.



|                                                           |           |          |
|-----------------------------------------------------------|-----------|----------|
| Full Instruction in Garment Cutting, including this Book, | - - - - - | \$100.00 |
| Coat System alone,                                        | - - - - - | 50.00    |
| Vest System alone,                                        | - - - - - | 25.00    |
| Pants System alone,                                       | - - - - - | 25.00    |

Half Price to Cutters wanting to change their system.

|                                 |                          |         |
|---------------------------------|--------------------------|---------|
| The Paramount Cutter alone,     | - - - - -                | 10.00   |
| Private Consultation in Cutting | - - - - - from \$5.00 to | \$20.00 |

Instructions given in English, German and the Scandinavian Languages.

☞ As I am employed during the day I give instructions evenings only.

**CHAS. J. STONE,**

CUTTER FOR JNO. O'CONNELL, Merchant Tailor,

COR. MADISON AND FIFTH AVENUE, CHICAGO, ILL.



MEYER & BROTHER,

PUBLISHERS.

PRINTERS AND BOOKSELLERS.

108 WASHINGTON ST.,

*S. E. Cor. of Clark St.,* CHICAGO.

SEND FOR ESTIMATES.





LIBRARY OF CONGRESS



0 014 082 902 A