

PREFACE

By DR. DAVID SNEDDEN,
Commissioner of Education for Massachusetts

During recent years profound changes have taken place in our theory and practice as to the teaching of science in elementary, secondary and normal schools. Fundamentally, this change has been in the direction of having our young people approach various scientific subjects through contact with the concrete examples and situations as these arise in the world of action, rather than through the abstract study of formulas, definitions, generalizations and principles. Our theories as to the value of this new pedagogy are still, of course, very far in advance of our actual practice. The novelty of studies like those contained in Monograph No. 5, relating to the "Mechanics of the Sewing Machine," is still sufficient to occasion the student of education a keen thrill of satisfaction. This monograph presents the results of constructive work in a field which should prove of very great value to our public schools. It must be recognized, of course, that each one of the proposals contained in that monograph is still necessarily tentative, from the pedagogical standpoint. Further experience may show the need of considerable modifications in the manner of presentation and in the scope of the matter dealt with.

But, in any event, every person interested in a more effective and a more practical education must welcome attempts like those shown in the monograph referred to. It is not unreasonable to hope that within a few years the whole subject of science instruction in our schools can be vitalized and made of great practical and cultural interest through similar approaches.

203382

INTRODUCTION

THE sewing machine promises to be used in the secondary schools of the United States in three distinct classrooms. The vocational sewing classes are now using them in large numbers. The history, or civics, or civic biology classes discuss the influence of the introduction of machinery into the home and its effects upon the life and customs of our times. Finally, the science classes use the sewing machine as a piece of mechanical apparatus to illustrate the simple laws of levers, friction, work, etc.

The Joint Committee on Physics has asked us to give in this publication a summary of the information thus far received as teachers in history, civics and science in high schools, vocational schools and colleges may appropriately use. The data given as to the probable number of machines in use and the economic gain of machine over hand sewing, we realize, do not answer all of the questions which may be raised regarding the influence upon the labor market and the home life by the concentration of garment work into shops where nearly all processes are machine operations. A discussion of this question in the civics class will help to give new light upon changes that are now taking place in the life habits of the women of this country.

Projects seem to be proving as valuable an aid to education as any new method or device. Projects which center around raising corn or operating some real machine seem to hold the student's attention while he obtains a practical grasp of the principles which need to be learned.

We have concluded that the best way to aid teachers in the use of the sewing machine as a project is to show how others have used it. We, therefore, must acknowledge our deep appreciation of assistance of Professor Frederick H. Beals, Barringer High School, Newark, N. J.; Miss Clara Schmidt, Mt. Vernon High School, Mt. Vernon, N. Y.; Dr. W. A. Hedrick, McKinley Manual Training School, Washington, D. C.; Mr. C. E. Harris, East High School, Rochester, N. Y., and Professor F. D. Barber, Illinois State Normal University, Normal, Illinois.

How to Teach Physics by the Use of the Sewing Machine

By DR. W. A. HEDRICK, Washington, D. C.

"Whether other people really teach us any thing is a question, but they do sometimes give us impulses and make us find out for ourselves. * * * Teachers of physics hope that the student may become interested in the physical world about him, and begin to organize his vast range of associated experiences about the fundamental ideas of physics."

In our school program, five periods of forty minutes per week are assigned to physics. The physics department spends three weeks in the study of machines; chapter II, pages 31 to 54, *Physics*, Mann and Twiss. To the exercise described below and the related part of the textbook are devoted four periods: two consecutive laboratory periods, preceded and followed by a recitation-lecture period. Teachers will find a strong tendency to ramble on account of the broadness of the subject—"Energy."

It is our practice to place before the class a chart of the sewing machine, with every part lettered for reference to its commercial name. The teacher describes the machine from the standpoint of "how sewing is accomplished by it." Briefly, two minutes are sufficient, the teacher talks from the historical standpoint about stitches and sewing; thorns were the first needles, then instruments made from less brittle material and with smaller diameter; then, sewing from the physicists point of view—"Work."

We ask about the advantages of using a machine; among others it enables us to use muscles other than those in our fingers and arms, and convenience in handling our materials; comfortable position; less intensely close attention; less eye strain; no rapid muscular effort; that we use our feet, not our hands, to push the needle through the leather or cloth; the table, needle bar, presser foot, etc., conveniently assist us. In the manner of the Socratic dialogue the students tell how the

energy given to the pedal is transferred] to [the needle; the names of the forces; muscular effort, elasticity, gravity and friction. In review, the student is asked the name of the force that does some particular thing, *e. g.*, the force that gives to the belt the capacity to transmit energy; or to name some part of the sewing machine where the force of elasticity is used. The object is to learn if the student has in his mind the thing signified or knows the word ordinarily used to describe what he desires to point out. We ask why oil is used on the bearings. We accept either answer: to make the machine run easier, or to reduce the friction. We must not stop until we get the latter one. Is it desirable to put oil or other lubricating substance on the belt so that it will run easily or slip on the driving and balance wheels? What will be the effect of making the belt a trifle shorter? Can we increase friction in any other manner? How is the tension or pull on the thread from the spool regulated? Should the tension regulator be moved when one stops sewing thin and loosely woven goods and starts to sew thick and closely woven goods? Is friction ever useful? Is the entire energy given to the pedals transferred to the needle? Is all of it used up in making the thread and the needle go through the cloth?"

Displacements: We give the class the names of the different kinds of movements and point them out simultaneously: rectilinear, curvilinear, reciprocating, revolving, etc. In review, we ask what kind of motion do the pedals make? the driving wheel? the belt? the take-up hook? the shaft? the shuttle? What parts of the machine do we desire to have a uniform motion? What parts have a variable speed while the driving wheel and the main shaft have a uniform velocity? Does the toe end of the pedal have the same speed as the heel end? Does the driving wheel make as many revolutions per $\frac{\text{minute}}{\text{second}}$ as the balance wheel? Approximate numbers are sufficient. Does the circumference of the driving wheel have the same linear speed as the circumference of the balance wheel? Does the belt have the same linear speed in every part of its length? What are the means by which one changes from a certain speed to a higher speed? From a uniform to a variable one? From a reciprocating to a rotary movement?

We describe the method by which the speed is changed in the pedals as the lever principle; the crank motion also as lever, but by some is called wheel and axle principle; the peculiar motion of the take-up is spoken of as the principle of the cam, this also is the lever but a kind of lever with the arms changing their length and moving; the wedge principle is used in the needle; the belt gearing to change the relative angular speed of the driving wheel and the balance wheel. This is the end of the exercise for the first day. It is largely a lesson in vocabulary, using concrete names for the purpose of leading to general terms. The number of concrete cases necessary is a question for the individual teacher. Pupils will generalize. Give them a chance. Assume that they are going to live to be three score years and ten.

The next part of the exercise involves measurements and is taken up in the two laboratory periods. In three minutes we review the work of the previous day and introduce the word "work." The idea involved in this word is not the same as force, though often used in this sense. It involves both force and displacement. Its value is always found by multiplying the number of the units of displacement by the number of units of force. The name given to the product is obtained by forming from the name of the units of displacement and the name of the unit of force a compound word, as foot-pound, inch-pound, inch-ounce or gramcentimeter, etc.

Work and efficiency: The student must record the numbers in the form of a table. The one at the end of the exercise is suggested.

Fasten a box on the pedal about half way between the pivot and the toe end of the pedal. Place the crank arm in its best position, *i. e.*, the crank arm at right angle with the length of the pitman. At the same time put the needle at its highest point. Now place in the box sufficient weights to make the needle bar move down, to ascertain how much force one must press with the toe to work the machine. Weigh the box and its contents. Get the weight three times (a) with nothing under the presser foot, (b) with one thickness of cloth under the presser foot, and (c) when two thicknesses of cloth are under the presser foot.

Measure the distance the weight must move when placed at toe end, while the wheel is making one-half a revolution. Measure the distance the weight moves, when placed at the heel end of the pedal while the driving wheel is making one-half a revolution. From the observations how will one calculate the amount of work one does to cause the driving wheel to make a complete revolution? Read paragraphs 13, 15, 16 and 17 in the textbook. Calculate the work put forth for case a, b and c.

Observe how many stitches are made while the driving wheel is making one revolution. Observe how many stitches are necessary to sew an inch of material. Calculate how much work is necessary to sew a yard in length when no cloth is under the presser foot, then when one thickness, and finally when two thicknesses of cloth are under the presser foot.

The following form is suggested for recording your results; use it or what is better make one for yourself. Should the distance between the individual observations be the same size as that between the series of observations and the series of calculations?

Observations

A			A'			B		B	
Force applied at toe end or effort			Force applied at heel end or effort			The distance the weight at the toe end moves, or effort distance.		The distance the weight at the heel end moves, or effort distance.	
a	b	c	a	b	c				
—	—	—	—	—	—	—		—	
—	—	—	—	—	—	—		—	
—	—	—	—	—	—	—		—	
Sum—	—	—	—	—	—	—		—	
Av. —	—	—	—	—	—	—		—	

Leave two (2) spaces between the two (2) sets of observations. Why?

Number of stitches made during one revolution of the driving wheel.....

Number stitches to an inch.....

Time to sew a yard, when one sews at the ordinary rate.....

Leave four (4) spaces between the observations and the calculations.

Calculations

$A \times B$	$A' \times B'$		
Work done inunits by Wt. at toe end dur- ing one half a revolution of driving wheel. a b c — — —	Work done inunits by Wt. at heel end dur- ing one half a revolution of driving wheel. a b c — — —	Total work in one (1) revolu- tion of the driv- ing wheel. a b c — — —	Amount of work one must do to sew a yard. a b c — — —

Read paragraph 96 on page 103 in *Physics*, Mann and Twiss, or look in the index under the word "power," and calculate the horsepower required to run a sewing machine. Read paragraph 208 on page 213 and calculate the appropriate power rating of an electric motor to run a sewing machine.

For the fourth period we review the work of the three previous periods, paying less attention to the specific terms and more to the general terms, especially the terms "energy" and "work" and "force." We use the numerical work especially to familiarize the students with the names and sizes, or magnitudes, of the units of "force," "work" and "power." We emphasize the standard units which have been adopted to facilitate commerce and communications. We question as to the method to change inch-pounds to foot-pounds; to convert inch-ounces to inch-pounds; we try to *avoid converting the class from a class in physics to a class in denominate numbers*. Singer sewing machines, sewing machines, machines, are the things we see, we endeavor to get the students to question about the cause of the motion, of the work, the mechanisms by which energy travels from one place to another, where some of the energy is lost, what becomes of it when it is no longer available to make the needle move.

Questions: If one moves the weight nearer to the toe end of the pedal, must he change the weights in the box to make the needle bar move; if one makes the crank arm parallel to the length of the pitman instead of at right angles will he have to exert more or less force to make the needle bar move; when must one start the machine by taking hold of the balance wheel and moving it by hand? Will the distance through which the

effort is exerted be increased or decreased when the force is applied further from the pivot or fulcrum of the pedal? In the case of the crank where is the fulcrum? What distance must one make large to make the force exerted by the pitman have the greatest effect? Bring out that this arm distance must be measured at right angles to the length of the pitman or force. Why does a child with weak muscles apply the toe to the pedal as far as possible from the fulcrum of the pedals? Must he move his feet through a greater distance than a person with stronger muscles? Must he do more work to accomplish the sewing with stronger muscles? To accomplish the same amount of sewing must the child or the grown person do the larger amount of work? In the above we try to get the student to associate both force and displacement with the word "work." The impossibility of perpetual motion is suggested at this point. When the force required to accomplish a given amount of work is small the corresponding distance through which it must be exerted is larger than when the applied force is large, and the opposite is true. I tell the students that work necessary to perform a certain operation does not depend upon the force or upon the distance but upon the product of the two. Ask the student what he thinks of the value or helpfulness of the force of gravity and the force of elasticity in the main shaft. Get the student to want to know something.

Dynamics of the Sewing Machine

By MISS CLARA SCHMIDT

Mt. Vernon High School, Mt. Vernon, New York

The following is a series of experiments performed in the laboratory of the Mount Vernon High School. They were performed by a class of thirteen students that were under conditions, and who were, consequently not in a very favorable frame of mind toward such experimentation. Considering this and several other circumstances that contributed to make the work extremely difficult, the results are decidedly worth the effort. That the experiments *can* be done by pupils of average ability has been proved, for the data herewith given are those obtained by one of this class. The advisability of spending the *time*, requisite to the proper execution of such experiments in the laboratory, is another matter.

However, as demonstrations, where the teacher can prepare the machine before the class, the readings can be very quickly taken; and there they would afford a very excellent series of lessons on machines. This last I was prevented from trying out because of a succession of changes in the personnel of our department.

Experiments I, III and V are suggested as class lessons. Each of these develops a fundamental concept; I, moments; III, work; and V, power. Experiments II and IV, on the other hand, apply the principles of I and III, and would be done without much difficulty by the pupils after the lesson.

The machine used for this experiment was the SINGER SEWING MACHINE NO. 115-1, one of their newer models, which will be found described in their pamphlet devoted to that purpose. I chose that model because it seemed to me to be the type of machine that the pupil would be most likely to have at home. At the various points were placed small eyelet screws for the attachment of strings. This facilitated the work, of course, and made it possible to secure the desired results.

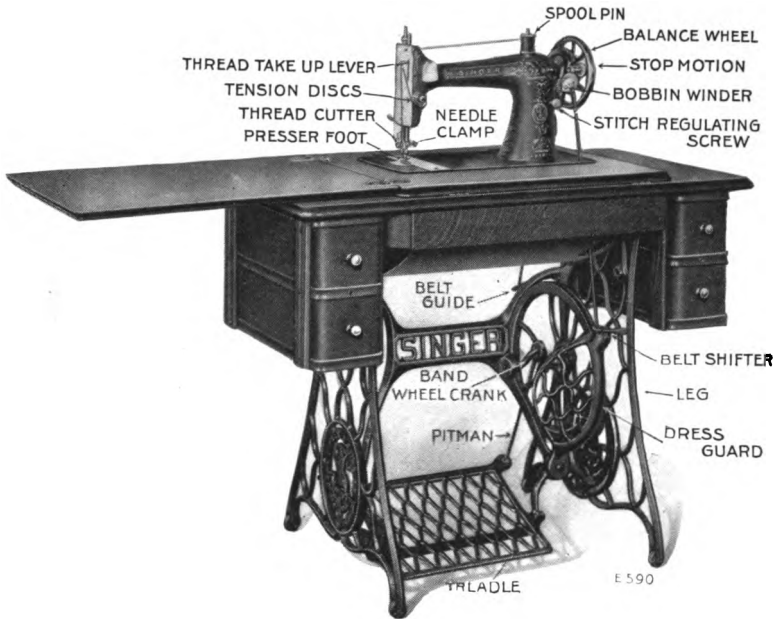

Experiment I. The Balance Wheel

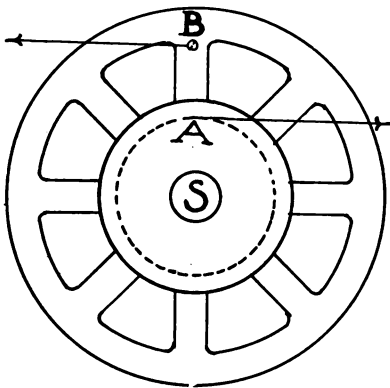

Balance Wheel

PURPOSE: To study the forces that act on the balance wheel.

APPARATUS: Singer Sewing Machine No. 115-1, two spring balances, a metric steel tape, a screw driver, pair of calipers, and some stout linen thread.

PROCEDURE: Be sure that the machine is in good working order, then remove the "bobbin winder," which is held in position by a single screw, and put this into the drawer for future use. Wipe any oil from the machine and then slip the belt or "strap" out of its groove in the pulley. Next release the stop motion screw by turning it toward you, and insert the small eyelet screws provided at *A* and *B*. Now the balance wheel will spin. Fasten the linen thread to the screws at *A* and *B*, a short piece will suffice at *B*; but at *A* the thread should be long enough to pass around the pulley five or ten times. With the thread so wound, secure a spring balance at the end of each thread. Being careful to hold the balance at *B* so that the thread is always tangent to the circle (or perpendicular to the spoke), draw the spring balances in opposite directions. Read and record the forces *A* and *B*. Keeping the thread at *B* tangent to the circle, exert a greater force at *A*, and repeat several times.

Thus you will obtain a series of readings in which the FORCES, of any pair, ARE EQUIVALENT TO EACH OTHER SO FAR AS PRODUCING ROTATION OF THE BALANCE WHEEL IS CONCERNED.

After several readings have been taken, reverse the winding of the thread on the pulley, and pull in the opposite directions. Record as before.

Remove the balance at *B*, and tighten on the "stop motion" screw *S*. A little practice may be necessary to make the machine run or even sew by moving the balance *A* at a uniform speed. The reading on the balance will vary considerably from the beginning to the end of the stroke, but with care, a fair average may be obtained. This will then be the force necessary to run the machine, if applied at *A*. With the calipers, determine the diameter of the pulley's groove, and the distance of *B* from the center of rotation.

TABULATION I

Record data as follows:

FORCE	A	B
Radius	2.85 cm	5.7 cm
Magnitude and Direction	1.5 kgm left 3 kgm " 3.2 kgm " 4 kgm right 3 kgm " 5 kgm "	.75 kgm right 1.5 kgm " 1.6 kgm " 2 kgm left 1.5 kgm " 2.5 kgm "
To run the machine	130 gms left 150 gms " 125 gms " 150 gms "	
Average	137 gms left	

DISCUSSION OF DATA: In the first six readings a striking relation is at once apparent. The point of application of *B* is twice as far from the center of rotation as that of *A*; but the force *A* is twice *B*. When these readings were taken the wheel was not in motion. Therefore if both forces were acting in opposite directions at the same time, they must have been equally effective in producing rotation of the wheel. This effectiveness is technically called the **MOMENT** of the force; and our data shows that it depends not only upon the magnitude of the force, but also upon the distance from the center. Consequently, in defining it we say that **THE MOMENT OF A FORCE EQUALS THE PRODUCT OF THE FORCE, BY THE PERPENDICULAR DISTANCE OF ITS LINE OF ACTION FROM THE CENTER OF ROTATION.**

In this case we are considering two forces that produce opposite rotations: these must be distinguished. If you stand facing the balance wheel while it is running you will see that the spokes move in a direction that is opposite to that taken by the hands of a clock. Such rotation, *i. e.*, **COUNTER CLOCKWISE ROTATION IS POSITIVE.** Hence in the first trial, the moment of *A* is $+ 1.5 \text{ kgm.} \times 2.85 \text{ cm.} = 4.28$, while the moment of *B* is $-.75 \text{ kgm} \times 5.7 \text{ cm} = -4.28$. Calculate the moments

of the forces in Tabulation I, remembering that the moment is positive if the rotation produced by that force alone is counter-clockwise; and negative if the rotation is the same as that of the hands of a clock. Record these calculations in Tabulation II.

TABULATION II

TRIAL	FORCE	MAGNITUDE	RADIUS	MOMENT	SUM
I	A	6 kgm	2.85 cm	+4.28	0
	B	.75 kgm	5.7 cm	-4.28	
II	A	3 kgm	2.85 cm	+8.55	0
	B	1.5 kgm	5.7 cm	-8.55	
III	A	3.2 kgm	2.85 cm	+9.12	0
	B	1.6 kgm	5.7 cm	-9.12	
IV	A	4 kgm	2.85 cm	-11.4	0
	B	2 kgm	5.7 cm	+11.4	
V	A	3 kgm	2.85 cm	-8.55	0
	B	1.5 kgm	5.7 cm	+8.55	
VI	A	5 kgm	2.85 cm	-14.42	0
	B	2.5 kgm	5.7 cm	+14.42	

Tabulation II shows an even more striking relation, viz., that the positive and negative moments are equal or that, since the measurements were taken when the wheel was still, **AT EQUILIBRIUM, THE SUM OF THE MOMENTS ABOUT A COMMON CENTER IS ZERO.**

CONCLUSION: I. We have found the force at A which will run the machine.

II. We have proven a very important law of mechanics, **THE SUM OF THE MOMENTS OF ALL THE FORCES TENDING TO PRODUCE ROTATION ABOUT A COMMON CENTER EQUALS ZERO.**

*In the case in hand, this law may be stated in another way: **RESISTANCE IS TO EFFORT AS THE RADIUS OF THE EFFORT IS TO THAT OF THE RESISTANCE.** A glance at Tabulation No. 1 will show that this is true for the wheel and the axle.

*NOTE: I should omit this myself because I think High School pupils have a horror of proportions and "give up" at the sight of one. This does not add any new ideas, consequently will only confuse them. It may be convenient as a matter of correlation but I prefer to have my pupils solve all of their lever and other machine problems by moments.

Experiment II. The Band Wheel

PURPOSE: To study the forces that act upon the BAND WHEEL.

APPARATUS: Same as in Ex. I, with an additional spring balance.

PROCEDURE: Remove the belt, also the large square headed screw that holds the wheel in position on the crank. It may be convenient to remove also the dress guard and the "head" of the machine, that it may be lifted to the table. The band wheel ought to spin as freely now as the balance wheel did when the stop motion screw was loosened. On a piece of translucent but rather stiff paper draw two concentric circles having the diameters 6.49 and 12.98 cm. respectively; and fasten this between the framework and wheel so that the center is opposite that of the wheel.

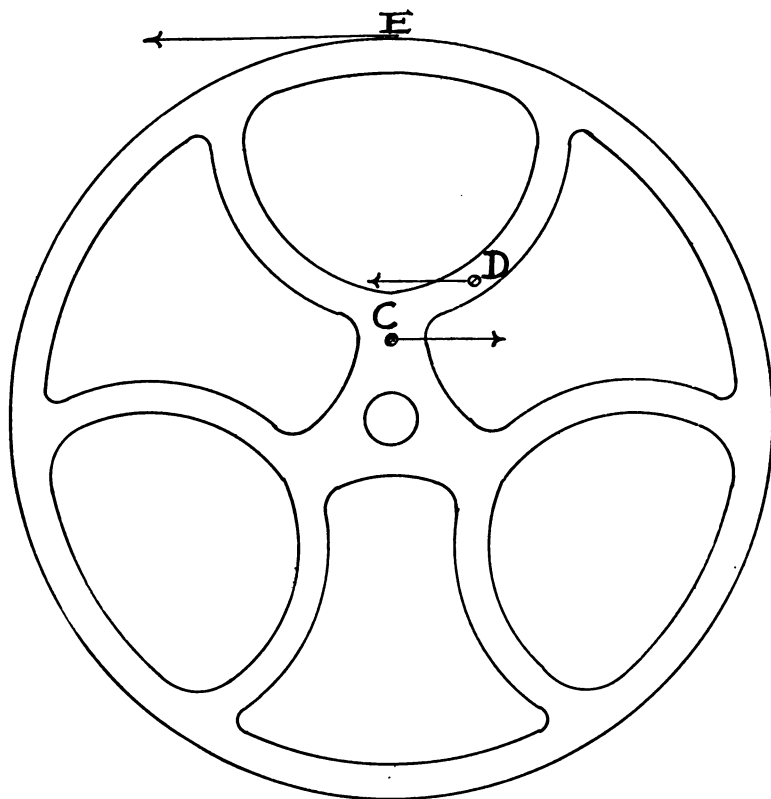

Band Wheel

Insert the eyelet screws at points *D* and *C*, and to them fasten threads as in Ex. I; likewise, wind the thread around the groove at *E* and apply the spring balance as before. Notice that the circles drawn on the paper exactly trace the path of the screws *C* and *D*; and that *C* is exactly opposite the crank, therefore will have the same advantage, *i. e.*, will be just as effective (it may be well to take the hand wheel out and check up the measurements of these diameters). It is extremely important to hold the thread conveying the force tangent to the circle describing its path. In this way, the distance from the center to the line of action of the force may be taken directly as the radius of the circle. Now take a series of readings, noticing in each case whether the moment of the force is positive or negative, according to whether it alone would have produced counter-clockwise rotation or not. Measure the distance of the points *D*, *C* and *E* from the center. Record data.

TABULATION III

TRIAL	FORCE	MAGNITUDE	RADIUS	MOMENT	SUM OR MOMENT OF FRICTION
I	<i>C</i>	0	3.25 cm	0	-0.005
	<i>D</i>	1.65 kgm	6.49 cm	+10.705	
	<i>E</i>	.7 kgm	15.3 cm	-10.71	
II	<i>C</i>	3.3 kgm	3.25 cm	+10.725	+0.015
	<i>D</i>	0	6.49 cm	0	
	<i>E</i>	.7 kgm	15.3 cm	-10.71	
III	<i>C</i>	2.4 kgm	3.25 cm	+7.676	+ .026
	<i>E</i>	.5 kgm	15.3 cm	-7.65	
	<i>D</i>	0	0	0	
IV	<i>C</i>	1.2 kgm	3.25 cm	+3.9	- .505
	<i>D</i>	.5 kgm	6.49 cm	+3.245	
	<i>E</i>	.5 kgm	15.3 cm	-7.6	
V	<i>C</i>	1.05 kgm	3.25 cm	+3.412	-0.49
	<i>D</i>	1.05 kgm	6.49 cm	+6.814	
	<i>E</i>	.7 kgm	15.3 cm	-10.71	
VI	<i>C</i>	0	0	0	+0.06
	<i>D</i>	1.5 kgm	6.49 cm	-9.74	
	<i>E</i>	.64 kgm	15.3 cm	+9.80	

CONCLUSION: These data show that the Law of Moments applies in the case of three or more forces in the same way that it applies for two.

NOTE: The reason for the fact that the sum of moments in this case is not zero, as in Ex. I, is that the difficulty in holding the thread tangent to the drawn circle was greater than in Ex. I. Moreover, I am not at all sure that this observer measured the diameters carefully. He did not remove the wheel to do so. By selecting the best in the class, I might have collected better data, but I thought it better to show where the difficulties lie. The average error in this case is about 2%; but most of it comes from the trial, where it was necessary to hold two balances tangent to the drawn circles at the same time. Another source of error came from the fact that the spring balances were very poor; they read correctly when held hook down, but the students were not always careful to hold the balance that way.

On the whole, they seemed to grasp the *principle* after doing this experiment. I gave them six problems on moments after they had completed it, and was surprised at the facility with which they solved them. I should suggest that if Ex. I were done in class, this might very easily be assigned for individual work in the laboratory.

Experiment III. The Band Wheel

PURPOSE: To study the forces that act on the band wheel with a view to finding new relations.

APPARATUS: The same as before with the addition of weights that can be suspended from a loop in the thread.

PROCEDURE: With the machine on the table, replace the balance *E* by a "weight."

By exerting a small force on a spring balance at *D* or *C*, the weight may be made to descend slowly. It is at once apparent that the weight at *E* moves more rapidly than the balance; also that it takes an unexpectedly large force to hold *E*. This is true of the values obtained in Tab. III. In common parlance we would say that "it is hard work to lift *E*." *Work*, as used in the scientific sense, is done whenever a force moves its point

of application in its own direction. In so doing, it must of course "overcome resistance," and in that case we may call E that resistance. D and C we may then call the *effort* to overcome that resistance. Both of these forces are doing *work*, which depends upon the force and the distance it moves its point of application in its own direction. With a weight at E and a balance at C or D , measure the force necessary to raise the weight a definite distance; also the distance the point of application of the effort is moved.

In order to find these distances, be sure that the paper, having the circles drawn on it, is in position. Since C and D are tangent to the circles, their direction may be taken to be that of the circle. Therefore, the distance the point of application moves may be measured on the circumferences, by putting a pin opposite the initial and final positions, and measuring the distance along the circumference. Now arrange a meter stick or weight the steel tape so that a scale will be as near as possible to the path that E will take in descending. Place a well-marked point on weight E opposite an even division of the scale, and a pin opposite the screw at D , and raise the weight, taking a reading of the force D when the thread is tangent to the circle.

Continue to raise the weight until it arrives at some other convenient point, and then place another pin where D has arrived. Measure the distance from pin to pin by bending the steel tape to fit the circumference. Record the data thus obtained in the first two columns of Tabulation IV. The other facts in this tabulation are obtained by calculation.

TABULATION IV

TRIAL	FORCE	MAGNITUDE	DISPLACEMENT OF POINT OF APPLICATION	WORK IN GMCM	EFFICIENCY
I	<i>E</i>	700 gm	95.7 cm	66,990	.99+
	<i>D</i>	1650 gm	40.75 cm	67,237.5	
II	<i>E</i>	700 gm	96.132 cm	67,292.4	.99+
	<i>C</i>	3300 gm	20.42 cm	67,386	
III	<i>E</i>	700 gm	97.1 cm	67,970	.95+
	<i>C</i>	1050 gm	20.42 cm	21,441	
	<i>D</i>	1050 gm	40.75 cm	42,787.5	

CALCULATIONS: Having the forces and the displacements of their points of application, we can now calculate the work. WORK is defined as the product of the force by the distance through which it acts. If we use the gravitational system of units, where the unit of force is the gram and the unit of distance the centimeter, then the unit of work is the gram-centimeter (gm. cm.) Calculate the work done in each case and record these results in the fourth column.

In a case where a rigid body like a stone is lifted vertically upward, the resistance moves in the same direction as the effort and just as far. Here too, the effort is equal to the resistance, for both are equal to the weight of the stone. Consequently, since the forces are equal and they move their points of application the same distance, the work done by each is equal to that of the other. In a machine the relation is not always so simple, but is complicated by the fact that there are other forces of friction, or slipping, that are not easily measured. Where these forces have been reduced to negligible quantities by lubrication or other means, **THE WORK DONE BY THE EFFORT EQUALS THAT DONE BY (or upon) THE RESISTANCE.** When this is not true, the machine is not perfectly efficient. **EFFICIENCY IS THE RATIO OF THE WORK DONE UPON THE RESISTANCE TO THAT DONE BY THE EFFORT.** We may state this principle by saying that efficiency is the ratio of "out-put" to "in-put."

It is interesting to compare the results of this problem with Ex. I, for if we let the wheel rotate 180°, then *E* will describe

a semi-circumference, but D and C also describe semi-circumferences. The Law of Moments leads to the conclusion that:

$$\text{Force } E \times \text{radius } 15.3 = \text{Force } D \times \text{radius } 6.49.$$

The Law of Machines, stated above, leads to the conclusion that:

$$E \times \text{radius } 15.3 \times 3.1416 = D \times \text{radius } 6.49 \times 3.1416.$$

It is at once apparent that the results are identical.

CONCLUSION: We have verified the general Law of Machines: the effort times the displacement of its point of application equals the resistance multiplied by the distance its point of application is displaced.

Further, we have defined **WORK** as the product of a force by the distance it moves its point of application; and **EFFICIENCY** as the ratio of the work delivered by a machine to that done upon it.

Experiment IV. The Pulley

PURPOSE: To study the relations that exist between the forces that act on the pulley.

APPARATUS: The complete machine with the balance wheel and the band wheel free to spin, steel tape and balances as before.

PROCEDURE: We have studied one kind of power transmission, the type in which wheels of different radii are fastened together rigidly, but rotate about a common axle. Now we are to consider a different means of transmitting power; here we have wheels of the same or different diameters fastened rigidly to different axles. The method of conveying the energy from one to the other is not through the axle, but through the agency of a belt or chain. In order that such a transmission shall be efficient, the belt must fit rather tightly so as to develop as much friction as possible between the belt and the wheel; but not so tightly that it will develop friction between the axle and its bearings. Another important factor is the length of arc over which the belt makes contact with the wheel. As a matter of fact, the efficiency varies with the log. of the angle, but that is a refinement with which we need not concern ourselves.

Place the belt in position, wind the long threads about the

wheels *A* and *E*, as in previous experiments, but be sure to wind them in opposite directions. If the thread will not stay in the groove of *A*, as we found to be the case, remove it and measure the force *B* instead. This is possible since we know from Ex. I that *B* is one-half of force *A*. In measuring the displacement of the point of application notice that both wheels move just as fast as the belt, *i. e.*, the belt measures its length on both circumferences, therefore we may take the length of the belt as a convenient measure. *B* will move just twice as far, and *C* and *D* will move through distances that are proportional to their radii.

Measure the forces, their displacements, and calculate the work done by each, also the efficiency. The mechanical advantage, which we know from a previous consideration of the inclined plane is equal to the ratio of the resistance to the effort, will be found interesting by way of comparison.

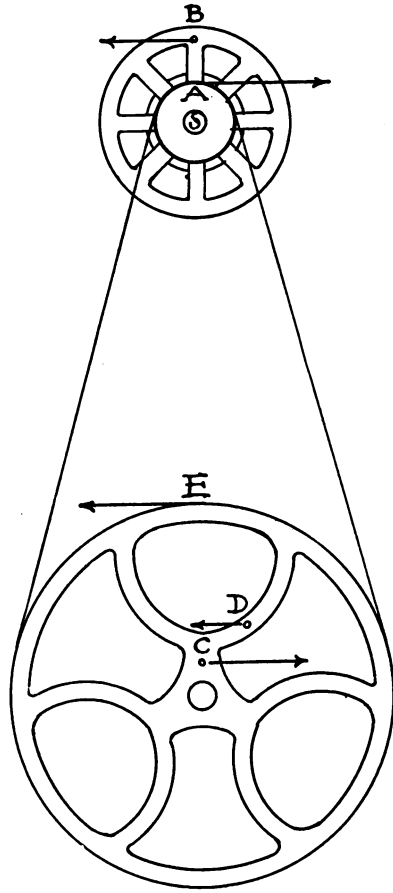

Pulley

Tabulate all of this data.

TABULATION V

FORCE	MAGNET	DISPLACE	WORK	EFFICIENCY	MECH. ADVANT.	
I	<i>B</i>	250 gm	310 cm	77500 gmcm	1	$\frac{B}{E} = \frac{1}{2}$
	<i>E</i>	500 gm	155 cm	77500 gmcm		
II	<i>A</i>	600 gm	155 cm	93000 gmcm	1	$\frac{A}{E} = \frac{1}{1}$
	<i>E</i>	600 gm	155 cm	93000 gmcm		
III	<i>B</i>	400 gm	310 cm	124000 gmcm	1	$\frac{B}{E} = \frac{1}{2}$
	<i>E</i>	800 gm	155 cm	124000 gmcm		
IV	<i>A</i>	1000 gm	155 cm	155000 gmcm	1	$\frac{A}{E} = \frac{1}{1}$
	<i>E</i>	1000 gm	155 cm	155000 gmcm		
V	<i>B</i>	500 gm	310 cm	155000 gmcm	0.95	$\frac{B}{E} = 0.101$
	<i>C</i>	4900 gm	32.8 cm	160720 gmcm		
VI	<i>B</i>	400 gm	310 cm	124000 gmcm	0.99	$\frac{B}{C} = 0.101$
	<i>C</i>	3800 gm	32.8 cm	124640 gmcm		

CONCLUSION: The data shows that the Law of Machines is true also for the pulley. We have found the efficiency of this pulley to be practically one.

Experiment V. Power

PURPOSE: To find how much power is developed in the pulley of this sewing machine.

APPARATUS: Machine as before, with the balances and steel tape.

PROCEDURE: The results of Ex. IV show that the Law of Machines applies to the pulley, and further experiment would prove that, not only this type, but also every type of pulley is amenable to this law. Likewise the wheel and axle and inclined plane have been found to conform to the principle that RESISTANCE MULTIPLIED BY THE DISTANCE IT IS MOVED EQUALS THE EFFORT MULTIPLIED BY THE DISTANCE IT MOVES.

But this system of pulleys involves one of the most important and commonly used methods of power-transmission we have; and is therefore worth further study. Notice that in Tab. V, trials II and IV, the two forces transmitted by the belt are equal (*i. e.*, $A = E$). If we had a chain instead of a belt,

as in the bicycle, the result would be the same. Or if, on the other hand, the band wheel had been moved up so that the circumference touched that of the balance wheel, the principle would have been the same, for the friction at the point of contact would cause the second wheel to rotate and again the forces at *A* and *E* would be equal, and the work equivalent. The small rubber winder will illustrate this. The transmission of power by means of toothed gears or "cog wheels" is of exactly the same nature; and all the difficulty in such problems will be dispelled if the aspiring physicist but remembers that the forces acting at the point of contact are equal and opposite, and the works done by them also equal.

But we have been discussing power as though it were a simple matter, and as if the "horse-power" could be found by a single measurement. POWER is the rate of doing work, *i. e.*, it includes the idea of time in which the work is done. In the (F. P. S.) foot-pound-second system of units, the unit of power is the ft-lb per second, or since that would give us very large numbers to work with, the more convenient unit, the horse-power 550 ft-lbs. per second, is employed. In the metric system, the gm. cm per sec., or the kilogram-meter per sec. may be employed. *One H-P equals 75 kg.m. per sec.* This will make it very simple for us to find the H-P of our machine. Since we know how to

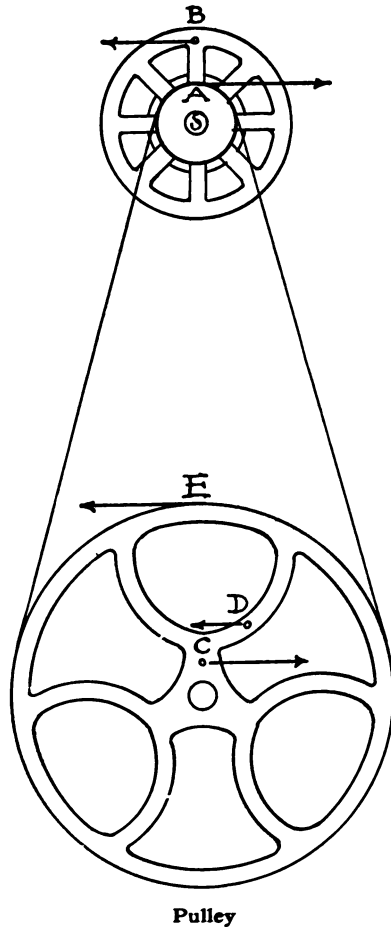

measure the work, we have only to time it and then reduce our work in gm. cm. per sec. to H-P by dividing by 7,500,000. For example, in trial IV, Tab. V, suppose that the wheel had been rotating at the rate of one revolution per second, when E was found to be 1000 gm., the point E would then move $2 \times 3.1416 \times 15.3$, or 96.2 cm. per sec., hence is developing 96,200 gm. cm. per sec. This is, of course, equal to 0.012 H-P.

Measure the force at *E* that is necessary to keep the machine running at a uniform speed, just as was done at A in Ex. I. This time the thread wound around the wheel at E will need to be rather long. While measuring the force, count the number of revolutions per quarter of a minute, and record these data in tabulated form, calculating power as directed.

TABULATION VI

TRIAL	FORCE	REV. IN 15 SEC.	DIST. PER SEC. IN CM.	GM. CM PER SEC.	GM. CM SEC. ÷ 7,500,000 = HP
I	160	15	$2 \times 3.14 \times 15.3$ = 96.2 cm	15,392 gmcm	0.00205 HP
II	160	20	$96.2 \times 20 \times 15$ = 115.3	18,448 gmcm	0.00245 HP
III	120	25	$96.2 \times 5 \times 3$ = 160 cm	19,200 gmcm	0.00256 HP
IV	100	30	$96.2 \times 2 =$ 192.4 cm	19,240 gmcm	0.00256 HP
V	100	200	1153 cm	230,600 gmcm	0.0306 HP

Average of trials I, II, III, IV = 0.0024 HP

Trial V of this investigation does not represent data actually measured, it was introduced merely to show the effect of a considerable increase of speed; the reason for choosing 800 rev. per minute is that this is the speed at which the motor-driven machines run.

CONCLUSION: We have found the power which must be applied at the circumference of the wheel E , in order to keep the machine running. This is 0.0024 H-P.

NOTE: This is not the same as the power necessary to start the machine, but the latter is almost impossible to measure, since the speed determination, in this case, is so difficult without proper instruments. It would seem, however, that the Singer Sewing Machine Co. is allowing a very generous factor of safety in designing a $\frac{1}{16}$ H-P motor to run this machine. Of course, the measurements in this last experiment can not be compared for accuracy with those of the purely static experiments. It is no simple matter to walk across a floor, holding a spring balance in the plane of a wheel and, at the same time, move at a uniform speed and read the force. The above forces were averaged for several trials at the same speed; but they show the principle, and the decreasing force with increased speed, as we would have expected.

Mechanical Advantage of the Sewing Machine

By C. E. HARRIS

East High School, Rochester, N. Y.

PROBLEM: To study the sewing machine and determine its mechanical advantage.

APPARATUS: Singer sewing machine, rule, calipers.

MANIPULATION: Examine the sewing machine. Make note of the simple *machines* you find and state the mechanical advantage of each.

Now begin at the treadle and show by the aid of a diagram how the simple *machines* are combined to form this sewing machine. In your conclusion, make it clear whether this combination of simple machines, or the sewing machine, gives any mechanical advantage. You may use the terms force ratio or speed ratio in the statement.

January 14, 1914

Catharine Weaver,
East High School, Rochester, N. Y.

PROBLEM: To determine the mechanical advantage of a sewing machine.

APPARATUS: Singer sewing machine, ruler.

MANIPULATION: The mechanical advantage of a machine is the advantage in speed, direction or effort, gained by using the machine. The sewing machine is a combination of some of the simple machines, such as the pulley, the lever, and the wheel and axle, and therefore has several separate advantages. I found by trials, that the small wheel made four revolutions while the large wheel made one. As the combination of the two, makes a pair of pulleys belted together, the advantage is four, a gain in time or speed, that is, the number of revolutions of the upper pulley to every one of the lower. The wheel and axle below the platform is a combination formed by the large wheel and its iron projection, to which the rod from the treadle is attached. The advantage of that machine is found by dividing the radius of the wheel by that of the axle, and in this case is $\frac{1}{4}$, a loss in effort. The reciprocal of the advantage in effort is an advantage in time, so the advantage in time of this wheel and axle is 4, since the reciprocal of $\frac{1}{4}$ is 4. The treadle is alternately a first or third class lever as the effort is changed from toe to heel. It also gives the advantage of a larger space for applying the effort.

INFERENCE: The mechanical advantage of the sewing machine is a gain in speed, which means that to every to-and-fro motion of the treadle the needle moves up and down four times, thus giving an advantage of four.

Household Appliances for Girls

By **FREDERICK H. BEALS**
Barringer High School, Newark, N. J.

The interests of the vast majority of women not only begin, but are centered and end, in the home. It is eminently worth while that the study of physics for girls should bear an intimate relation to the problems of home life. An important reason why girls have often "hated" physics is because the subject matter they have been called upon to learn is neither related to their previous experience nor to the problems of life which they as women will be called upon to face in the future.

There is just as much educational value in the study of sewing machines, fireless cookers, thermos bottles, electrical heating appliances, vacuum cleaners, furnaces and many other household appliances as in static machines, Wheatstone bridges, Young's Modulus Apparatus, Atwood machines and other far-from-life devices with which physics courses have often been loaded.

Three or four days were spent by *all* girls' classes at Barringer High School this year on the study of the sewing machine. Some of the pupils wished to take up a further study of the sewing machine as a special problem. For this extra credit was given and much interest aroused in working with real things rather than with laboratory "toys." Whether a large drive wheel and small balance wheel (or vice versa) is better adapted to rapid stitching, why some machines work "harder" than others, whether a machine gains at the same time both speed and force, were some of the problems considered by the whole class.

The following directions (for Exp. I) were given at Barringer High School, Newark, N. J., as an introduction to the study of simple machines, and the accompanying report sheets from pupils were among those handed in. Suitable directions were given for the starting of each of the following six experiments (except Exp. 3) and the pupils were encouraged and urged to do independent and original thinking and experimenting.

DIRECTIONS FOR EXERCISE 1.

“Draw, briefly describe, or otherwise indicate for tomorrow at least one illustration of each of *the six simple machines* employed in the construction of your sewing machine. The chief object of this exercise is to teach you to observe, to acquaint you with the six simple *machines*, and to consider the main purposes of *machines* in changing direction and amount of force. *Ideas*, not mere terms, are important. The terms, lever, pulley, inclined plane, etc., are given merely to help you to see relations more clearly and to cause you to think how all machines are related to simple principles though they may, apparently, have very complicated construction.”

1. The Six Simple Machines.

PHYSICAL LABORATORY

BARRINGER HIGH SCHOOL

Name Charlotte Cooper

Exp: 1 - page 2.
Period IV-3

Date March 12-17

3

Number each experiment.

FREDERICK H. BRAD
BARRINGER HIGH SCHOOL
NEWARK, N. J.

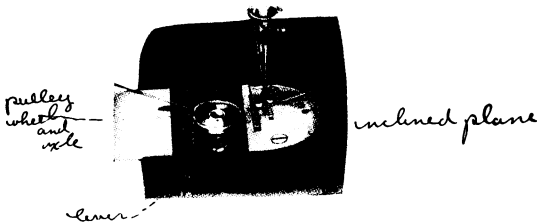
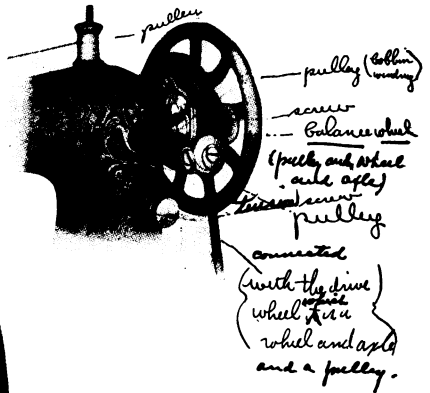
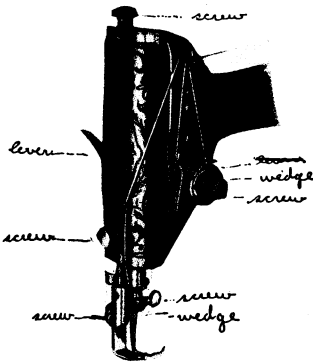

Exp. 1 - page 1.

FREDERICK H BEALS
BARRINGER HIGH SCHOOL
NEWARK, N. J.

Democrat Sewing Machine.

Mar. 10, '14.

Science Textbook. II-20.

Ref Home Study.

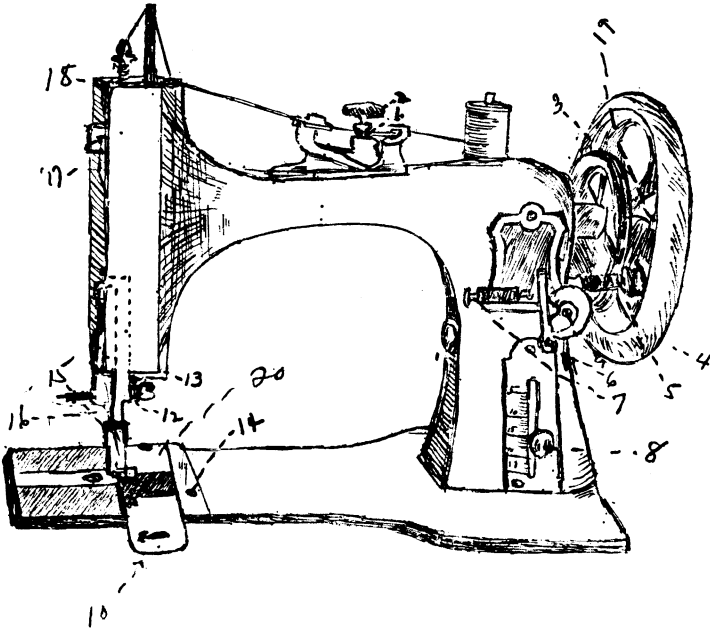

1. "Friction Plate" - Incline Plane.
2. " " "Screw" - Screw.
3. "Belt Pulley" - Pulley.
4. "Balance Wheel" - wheels & axle.
5. "Bobbin Winder Pulley" - Pulley.
6. "Lever" - Lever.
7. "Bobbin Winder Spindle" - Screw.
8. "Stitch Regulator" - Screw, a curved wedge.
9. "Cam Screw" - Cam.
10. "Front Slide" - Incline Plane, wedges on edges.
11. "Presser Foot" - Lever, mechanism, plate to compress cloth.
12. "Candle Clamp" - Screw.

Exp. 1 - page 3.

The Six Simple Machines

March 10, 1914

Lillian Prunsky

II - 15

Home study

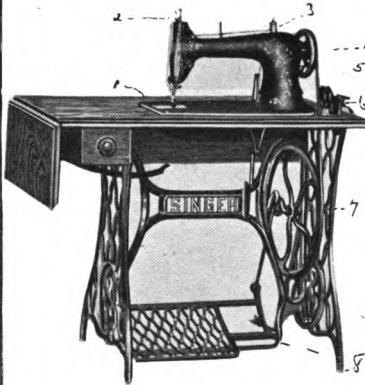

1. Wedge - (needle)
2. screw
3. pulley (spool)
4. wheel and axle with belting to use as pulley.
5. screw to regulate pitch
6. screw
7. wheel and axle with belting to use as pulley
8. lever with fulcrum as treadle pivot
9. tension screw
10. wheel and axle
11. screw (tension)
12. inclined plane
13. screw
14. wheel and axle

(8)

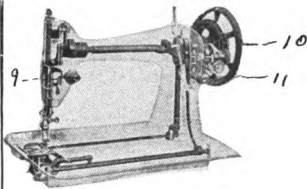

Attachment for lock-stitch

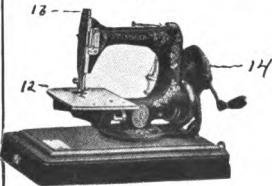

Attachment for ruffling and pleating

2. Home Study of Sewing Machine

INTRODUCTION:

A household appliance illustrating and employing various types of physical machines, is the sewing machine. It is so common as to make it almost impossible to think what our civilization would be without it. It contributes to human comfort to a degree we can hardly realize. The "drudgery of the needle" was no myth before the sewing machine was invented. No such thing as a sewing machine was known when your grandmother was born. In 1846 Elias Howe of Massachusetts was given a patent and in 1844 he claimed to have devised the eye-point needle and the interlocking shuttle. He realized between one million and two million dollars on his invention.

Mr. Singer "in particular seems to have gone through the entire range of devices which were capable of being applied to the purpose of machine sewing, reciprocating, vibrating and rotating shuttles, and various forms of these latch-takers or chain-stitch machine feeds of all kinds, tension devices, sewing machine attachments of all sorts, etc."—Johnson's Cyclopoedia.

HOME EXPERIMENT. Performed by Marguerite Thompson, Barringer High School, Newark, N. J.

May, 1914.

Questions and Answers

1. What is the make of your machine? Singer.
2. What is the circumference of the drive wheel where the belt runs? 38 inches.
3. What is the circumference of the balance wheel where the belt runs? $9\frac{1}{2}$ inches.
4. How many times does the balance wheel go around when the drive wheel goes around once? 4 times.
5. How many stitches does the machine take for one revolution of the balance wheel? 1 stitch. The drive wheel? 4 stitches.
6. How many stitches does the machine take for one complete motion of the treadle? 4 stitches.
7. When the drive wheel turns half way around how far does the heel side of the treadle move from its highest to its lowest position? $2\frac{3}{4}$ inches.

8. What is the ratio of velocities between the circumference of the balance wheel and the circumference of the drive wheel? 1.
9. When the balance wheel turns around once how much thread can be wound in by the bobbin winder? 2 inches.
10. When the drive wheel turns around once how much thread can be wound in by the bobbin winder? 8 inches.
11. How much cloth can the feeder pull in when the balance wheel turns around once, for long stitches? $\frac{1}{4}$ inch. For short stitches? $\frac{1}{8}$ inch.
12. When the heel side of the treadle goes down once, making a half revolution of the drive wheel, how far can the machine sew (that is how much cloth can the feeder pull in) with long stitches? $\frac{1}{2}$ inch. With short stitches? $\frac{1}{4}$ inch.

3. The Operation of a Singer Sewing Machine

HOME EXPERIMENT. Performed by Jennie V. Hanaway,
Barringer High School, Newark, N. J.

May 22, 1914.

APPARATUS: Singer Sewing Machine Model No. 27-4.

OBJECT: To make a general study of the Singer Sewing Machine in regard to the action of its various parts.

Questions and Answers

1. How many complete movements are made, for my ordinary rate of sewing, by the heel treadle in one minute?
Ans. 118.
NOTE: I used this value (118) for all succeeding cases.
2. How many large stitches are made in one minute when the heel treadle makes 118 complete revolutions? Ans. 378.
(8 stitches to the inch.)
NOTE: I used white lawn and sewed with black cotton.
3. How many small stitches are made in one minute when the heel treadle makes 118 complete movements? Ans. 438.
(32 stitches to inch.)
4. How many inches of goods can be pulled in during one minute when the stitches are large? Ans. $48\frac{3}{4}$.
When the stitches are small? Ans. $13\frac{1}{2}$.

5. How many inches of cotton can be wound around the bobbin in one minute? Ans. 1140.

NOTE: When cotton No. 70 is used, nearly 100 ft. of thread can be wound around the bobbin in one minute.

6. How many times does the bobbin go back and forth in one minute? Ans. 157.

7. If the thread breaks continually, what is the trouble? Ans. The tension screw may be too tight, or the needle point may be dull or broken.

INSTRUCTOR'S COMMENT:

The above experiment was performed by Miss Hanaway upon her own initiative. She proposed and answered her own questions.

4. Relative Movements of Various Parts of the Sewing Machine

April, 1914.

Performed by Evelyn Gordon,
Gertrude A. Freygang,
Barringer High School, Newark, N. J.

APPARATUS: Singer Sewing Machine, tape measure, cord and a foot rule.

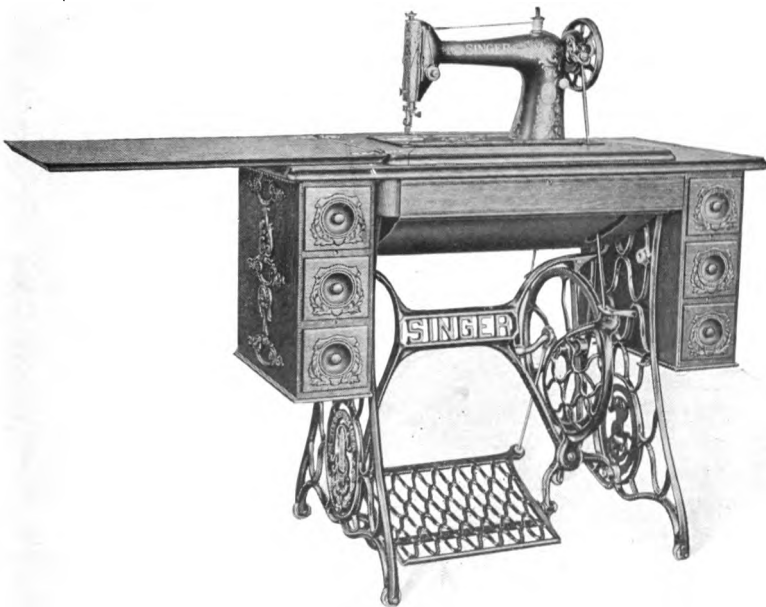

PROCEDURE: *I. Relation between the movements of the needle and balance wheel.* The needle makes one complete movement when the balance wheel makes one revolution.

II. Comparative revolutions of pulleys. The circumference of the balance wheel "A" (measured by means of a cord around the groove where the belt runs) is $9\frac{3}{4}$ inches.

The circumference of the drive wheel "B" is $38\frac{1}{2}$ inches. Both circumferences are connected by the same belt.

$$38\frac{1}{2} \div 9\frac{3}{4} = 4.$$

Hence, the balance wheel turns around 4 times while the drive wheel turns around once.

III. Relation between the movements of the needle and drive wheel. From I and II we find that while the drive wheel makes one complete revolution, the needle makes 4 complete movements.

IV. Relation between the movements of the needle and treadle. From I, II and III it is evident that every time the heel pushes down the nearer side of the treadle, the needle makes 4 complete movements.

V. Relation between the movements of feeder and treadle. Since the feeder goes up when the needle goes up and down when the needle goes down, it is evident from IV that every time the nearer side of the treadle is pushed down, the feeder makes 4 complete movements.

VI. Speed ratio of the treadle and circumference of the drive wheel (band groove). When the drive wheel makes one-half of a revolution, the heel side of the treadle moves $2\frac{3}{4}$ inches, *i. e.*, from its highest to its lowest position.

From *II* we find that half the circumference of the drive wheel (where band runs) is $38\frac{1}{2} \div 2 = 19\frac{1}{4}$ inches. But the circumference of the drive wheel moves $19\frac{1}{4}$ inches while the heel side of the treadle moves $2\frac{3}{4}$ inches.

Hence, the speed ratio of the circumference of the drive wheel to the nearer side of the treadle is $19\frac{1}{4} \div 2\frac{3}{4} = 7$.

VII. Speed ratio of the needle and nearer side of treadle.

The distance that the needle moves during one-half revolution of the balance wheel ($4\frac{7}{8}$ inches) is the full stroke upward of the needle or $1\frac{3}{16}$ inches.

Hence, the needle moves as many times as fast as the circumference of the balance wheel as $4\frac{7}{8}$ is contained in $1\frac{3}{16}$ or about 0.25 or $\frac{1}{4}$.

But we found from *VI* that the circumference of the balance wheel moves 7 times as fast as the nearer side of the treadle.

Consequently the needle moves $\frac{7}{4}$ as fast as the nearer side of the treadle; hence, the speed ratio of the needle and nearer side of the treadle is $\frac{7}{4}$.

VIII. Mechanical Advantage. A machine cannot increase in both speed and force at the same time, but a gain in speed is off-set by a loss in force.

Mechanical advantage is said to be the reciprocal of what we have here called Speed Ratio or $\frac{\text{force taken out}}{\text{force put in}}$

Hence, Mechanical Advantage is four-sevenths for the needle and heel side of the treadle.

5. Foot Pressure Force to Drive the Needle

May, 1914.

Edith Dansereau,

Barringer High School, Newark, N. J.

Home study of Singer Sewing Machine.

OBJECT: To find how much foot pressure (force) must be applied to the treadle to sew through different kinds of cloth of different thicknesses.

METHOD OF PROCEDURE: The machine was placed on two chairs to raise it so that weights could be hung from the treadle. Cloth was put into the machine as in ordinary sewing and a weight hung on the toe side of the treadle, three and one-half inches from the axis of turning of the treadle (the fulcrum).

It was found that the weight required to force the needle through the cloth varied considerably with the position of the crank arm on the drive wheel and so a position of the drive wheel was chosen which would give nearly maximum driving force on the needle. This position of the wheel was the same in all of the trials so that the following comparisons are under as nearly the same conditions as could readily be obtained in successive trials.

RESULTS:

CLOTH	THICKNESS	WEIGHT		CLOTH	THICKNESS	WEIGHT	
Gingham	1	4 lbs.		Linen	3	4 lbs. 6 oz.	
"	2	4 "		"	4	4 " 8 "	
"	3	4 " 1 oz.		"	5	4 " 10 "	
"	4	4 " 2 "		"	6	4 " 12 "	
"	5	4 " 3 "		"	7	4 " 14 "	
"	6	4 " 4 "		"	8	5 "	
"	7	4 " 5 "		Wool	1	3 "	
"	8	4 " 6 "		"	2	3 "	
Cotton				"	3	3½ lbs.	
(English	1	5 "		"	4	3½ "	
Long)	2	5 "		"	5	4 lbs.	
"	3	5 " 2 oz.		"	6	4 "	
"	4	5 " 2 "		"	7	4½ lbs.	
"	5	5 " 4 "		"	8	4½ "	
"	6	5 " 4 "		Felt	1	5 lbs.	
"	7	5 " 6 "		"	2	6 "	
"	8	5 " 6 "		"	3	7 "	
Linen	1	4 " 2 "		"	4	9 "	
"	2	4 " 4 "		"	5	15 "	

6. Efficiency of the Sewing Machine

May, 1914.

Edith Dansereau,
Barringer High School, Newark, N. J.

Home Study of the Singer Sewing Machine.

OBJECT: To find the efficiency of a Sewing Machine.

EXPLANATION: The ratio of velocities between the needle and the treadle was found by Miss Freygang and Miss Gordon to be $\frac{7}{4}$. This value is to be used in obtaining efficiency which depends upon both distance and force. Work is measured by force through distance. In order to obtain the average force on the treadle required to move the needle weights were hung on the treadle much as in the preceding exercise, "Force to Drive the Needle."

A hole was made in the center of a small board so that it fitted tightly on the top of the needle bar. Then weights were placed on this board and other weights on the treadle (at about

3½ inches from the axis of turning as in Miss Gordon's experiment) until there were enough weights on the treadle to raise the needle bar. The weights were changed and results obtained as in data:

Weight upon Needle	Weight upon treadle to cause needle to rise.
1 lb.	9 lbs.
2 lbs.	10 "
3 "	11 "
4 "	12 "
5 "	13 "
6 "	14 "
7 "	15 "
8 "	16 "
9 "	17 "
10 "	18 "
<hr/>	<hr/>
Average 5.5 lbs.	13.5 lbs.

$$\text{Efficiency} = \frac{\text{Work taken out}}{\text{Work put in}} =$$

$$\frac{\text{Weight on needle} \times \text{"distance moved"}}{\text{Weight on treadle} \times \text{"distance moved"}} = \frac{5.5 \times \frac{7}{4}}{13.5 \times 1} = 71\%$$

INSTRUCTOR'S COMMENT: The teacher should call the pupils' attention to the fact that they cannot obtain efficiency of the sewing machine for all cases, but that they can do so within sensible accuracy for a given position of the crank arm of the drive wheel. The position of the crank arm chosen in the above test was upward and backward at about 45° from the vertical.

The Study of the Sewing Machine in Normal School Physics Classes

FRED. D. BARBER
Illinois State Normal University

For several years the writer has used the sewing machine as an introduction to the study of machines in his normal schools classes of young women. Only two periods, one a laboratory period of 100 minutes and one recitation period of 45 minutes are devoted to the study of the sewing machine. Machines of various types are available for class work: A chain-stitch single-thread machine, and lock-stitch machines of several types; vibrating shuttle, oscillating hook and oscillating shuttle, rotary hook and rotary shuttle.

About 20 minutes are used in an opening explanation in which the purpose of the exercise is stated, the types of machines are stated, and brief mention is made of the social and economic significance of the sewing machine. The students are then handed the following sheet of laboratory directions:

A Study of the Sewing Machine

(Three students in each group. Spend 50 minutes on the first machine and 30 minutes on the second).

1. Note the name of the machine.
2. Note how the motion of the treadle is transferred to the drive wheel by means of the pitman. One complete vibration of the treadle produces how many revolutions of the drive wheel?
3. Measure the diameter of the drive wheel. What is its circumference? Determine the circumference of the pulley on the head of the machine over which the belt passes.
4. Provided there is no slipping of the belt, how many revolutions of the pulley will be produced by one revolution of the drive wheel?

5. Turn the pulley carefully by hand and determine how many stitches are taken by the needle for each revolution of the pulley. How many stitches are then taken for each complete vibration of the treadle? Carefully move the treadle through one complete vibration while counting the stitches taken. Does this check with your calculation?

6. Place a piece of cloth in position and stitch a seam for 10 seconds by the watch. One assistant is to watch the time while the second assistant counts the number of vibrations of the treadle. How many stitches, then, did you sew in the 10 seconds? How many per minute would that make? (Some manufacturers claim that as many as 3000 stitches per minute have been sewed by their machines.) How many stitches per minute do you consider rapid sewing?

7. Remove the face plate and while turning the balance wheel slowly by hand discover exactly how the rotary motion of the pulley, balance wheel and arm shaft is changed to a vibratory motion of the needle bar and the take-up lever.

8. Note how the presser foot is raised off the cloth. What is the purpose of the presser foot?

9. Examine carefully the feeding device and note exactly how it works. Just how is the length of the stitch regulated?

10. Is the machine a chain-stitch or a lock-stitch machine? If it is a lock-stitch machine determine whether it is (1) a rotary hook or rotary shuttle machine, (2) an oscillating hook or oscillating shuttle machine, (3) or a vibrating shuttle machine.

11. Determine exactly how the knot is produced. Does the loop which forms the knot pass completely around the hook or shuttle? If so, describe exactly how this is accomplished. Can the hook or shuttle be rigidly attached to any fixed or moving part of the machine? Do not decide this point until you have made a very careful study of the way in which the knot is formed.

12. Secure sample seams of a chain-stitch seam and a lock-stitch seam each sewed in rather thick, loosely woven cloth cut on the bias. Examine each seam; first, to determine which seam is the more elastic, and second, to note the ease with which each may be ripped. Can either seam be ripped by the breaking of a single thread?

13. We use machines only when we gain some sort of advantage by so doing. List all advantages you can which we attain by using a sewing machine over using the hand needle.

The following day the recitation period of 45 minutes is devoted to recitation and discussion.

As is evident from the above laboratory outline we do not use the sewing machine extensively to study the principles of the simple machine. It is used rather to enlist the interest of the young women in the sewing machine as a useful appliance affecting our social and economic life and to excite their interest in use of machines in general.

The study of machines as usually approached in text-books is distasteful to girls; they fail to see the worth-whileness of devoting so much time and energy to the mastery of the principles of machines; they regard such matters as being principally of interest and value to boys. Their experience with high school texts in physics confirm them in this judgement. Little or no attempt, apparently, has been made in the past by writers of physics texts to develop mechanics as that science is related to the usual sphere of activities of women. In fact, in the past, high school physics in general has been headed most directly towards engineering and for boys. Girls respond much more graciously and with much greater interest to the study of machines and mechanics in general if the approach is made through the non-technical study of such machines as the sewing machine, the cream separator and the vacuum cleaner. But the point cannot be too strongly emphasized that it is the social and economic value of these machines which most strongly appeal to them.

The ignorance of even well-informed women regarding the machines they use is astounding. Some years ago the writer asked a teacher of domestic art holding a responsible position and generally regarded as a capable teacher of her subject how many stitches are taken by the ordinary sewing machine for each complete vibration of the treadle. She declared that that question had never before entered her mind. Upon being pressed to make a guess she said probably about 60. After discovering her blunder she asked several of her women friends the same question and received replies ranging from 7 to 125. The same teacher of domestic art could suggest but one

advantage, off hand, of the sewing machine over the hand needle; that of doing more rapid work. I have never yet discovered one girl in my classes who was able, previous to the study of the sewing machine as a set exercise, to attempt an explanation of the exact way in which the knot was formed. Nor have I discovered a girl who had ever attempted to analyze the advantages of the sewing machine over the hand needle. Few girls know how to oil a machine properly much less to clean one.

Ignorance of the construction, operation and care of the sewing machine is without doubt partly responsible for the fact that there are today in private homes perhaps ten million machines that are seldom used.

From several years' experience of teaching the sewing machine as indicated above, I am convinced that the following results are usually obtained from our brief study of the machine:

1. The young women see that a study of machines in general is of value to them, and may well be required as a part of a liberal education.

2. They feel more at home with the sewing machine than with any other form of machinery available for study in school. As a consequence they undertake the study of that machine with interest; they readily follow the directions and usually complete the exercise within the allotted time.

3. When the study is completed the girls have usually acquired considerable confidence in their ability to undertake the study of the essential features of other machines. Moreover, their whole attitude towards the study of machines and mechanics is changed. They lose almost completely their aversion to such study—an attitude of mind which I find common in girls of high school age and even common in mature women.

The Sewing Machine—Its History

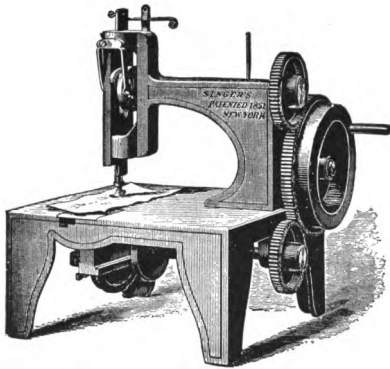

The First Singer

The sewing machine has justly been called "America's Chief Contribution to Civilization," and one of the principal causes for the general diffusion of well-being among the people of the United States is found in the wonderfully diverse uses of mechanical contrivances to take the place of manual labor. So far as men and women can substitute for the

direct output of physical strength the more intelligent effort of guiding a machine, they are so far uplifted in the scale of being, because they are enabled to make their lives more interesting as well as more productive.

It is in the invention of machinery—which not only economizes but elevates human nature—that American ingenuity excels; and the Singer Sewing Machine is one of the most conspicuous examples of this kind of invention.

Most of the really great inventions have been products of slow growth rather than an inspiration, and the sewing machine is no exception to the rule. It had been in process of evolution for more than a century previous to 1850 when Isaac Merritt Singer's versatile brain became attracted to the problem of machine sewing.

His first machine, patented Aug. 12, 1851, had a vertical needle movement, driven by a rotary overhanging shaft, and a roughened feed wheel extending through a slot in the table. A

yielding presser foot alongside the needle held down the work. Motion was given to the needle arm and the shuttle by gearing. It used two threads and made the lock stitch, the loop of the needle thread being interlocked at each downward movement by the thread of a reciprocating shuttle.

The patented features of Singer's invention showed no wide departures from the developments of earlier inventors. It was the practical adaptation and utilization of his own and other ideas that marked his inventions, some of which were not fully appreciated when they might have been patented but were neglected. As an example, the combination of the rotary shaft in the overhanging arm, also the rocking treadle. Both of these are now dominant in sewing machine construction.

The ground floor of sewing machine invention was established before Singer came on the field. It was too late for original dominant patents, but his clear perception of other men's work which was at his hand led him in the line that succeeding invention was to follow.

Singer had a hard struggle at the outset; he was poor and had to contend with popular prejudice due to the previous failures of others to produce a successful working machine. Slowly he gained ground; gradually he obtained access to the public so that by degrees his machine received a trial and was shown successfully to accomplish continuous stitching.

The leading counsel for Singer in all his early trials soon became actively interested as an equal partner in the business, he having fully comprehended at an early day the great value of the sewing machine as a factor in the world's industrial development. The firm of I. M. Singer & Co. was now formed. Its policy always contemplated the diffusion of the business in every direction, following the most direct method of placing its products in the hands of the consumer. In 1856 it originated and inaugurated the system of selling sewing machines on the renting or installment plan; this method has since been extended all over the world by The Singer Manufacturing Company, which was incorporated in 1863.

The first machines sold were intended to be set up on the packing cases in which they were transported; a rough wooden pitman connected the treadle to the geared balance wheel, as illustrated below.

A poster advertising the merits of the machine was pasted on the outside of the packing case, which thus constituted the first Singer Cabinet.

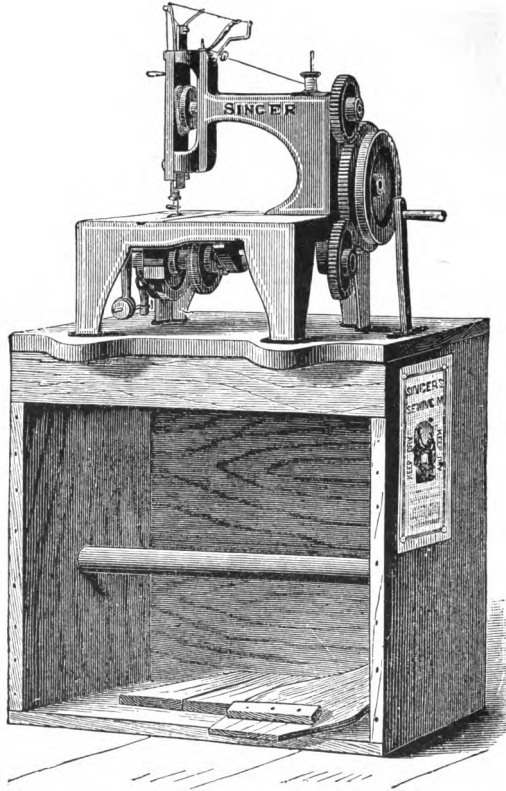

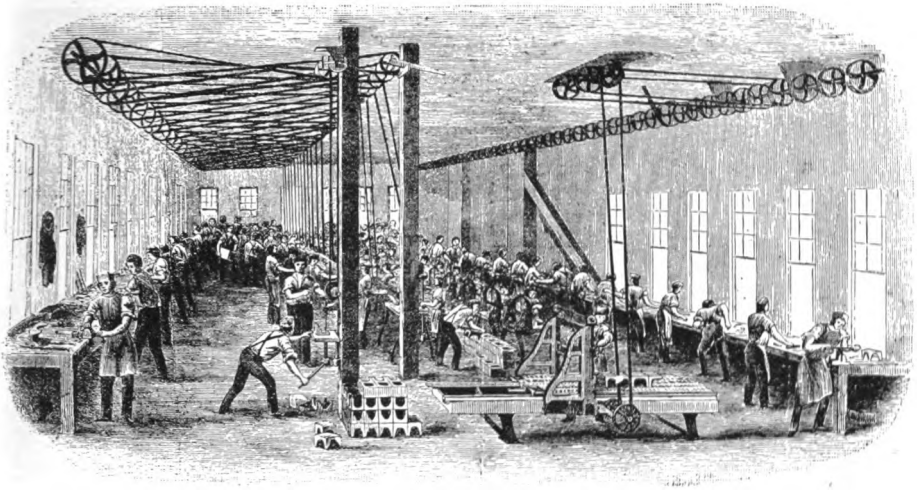

Singer's Sewing Machine Factory, Centre St., New York City
 Facsimile of illustration published in August, 1853

The Singer Factories

The first Singer factory in New York, illustrated above, was a room 25 x 50 feet on Centre Street, over the old New Haven depot. It is apparent that the greater part of the sewing machine construction at that time was produced by hand work at the bench, so that no two machines or the parts composing them were precisely alike, either in shape or fitting. Special tools for making each part exactly like its fellow, the "assembling" system, and the "Singer Gauge" system had not been developed at that time.

Business soon outgrew the facilities at Centre Street and, in 1858, new factories, with more modern equipment, were operated at Mott, Spring, Delancey and Broome streets, until, in 1872, all these were combined on the location of the present factory at Elizabethport, N. J. In 1882 this site covered 32 acres of land and had 3,000 employees. It now covers 72 acres and has more than 9,000 employees. The factory at Bridgeport, Conn., has a ground area of about 13 acres and a floor area of 517,000 square feet. Other immense Singer factories, employing many thousands of workmen, are located in Canada, Scotland, Germany, Austria and Russia. Singer woodworking factories, the largest in the world, are operated in Arkansas, Illinois and Indiana.



Singer Machine, No. 3 Standard

Evolution of the Singer Machines

In 1852 a modification of the first Singer machine was put on the market and was called the "No. 1 Standard"; it was essentially a machine for manufacturing purposes and several hundred thousand were sold previous to 1880. It was succeeded by the "No. 2 Standard" in 1854. This also was similar to the "No. 1" but had greater capacity; it was fitted with either the rolling, the vibrating or the spring presser, according to the class of work it was to accomplish. It was heavier than the No. 1 and had more room under the arm. In 1856 the "No. 3 Standard" was brought out. This too was similar to its predecessors in its mechanism but was especially designed for stitching leather in carriage trimming and harness manufacture. It has 18 inches clear space under the arm and is a standard machine to-day for its purpose.



Singer Machine "The Turtle Back"

The first Singer machine specially designed for family sewing was commonly known as "the Turtle Back" and was produced in 1856. It had a vibrating overhanging shaft, for actuating the needle-bar, and a reciprocating shuttle. Motion was given to the mechanism from the rocking treadle through a driving wheel carrying a broad leather belt capable of carrying much greater power than was required for its purpose.

Singer's first machines for family use were succeeded in 1859 by the "Letter A" machine. These machines became popular at once and their inherent excellence is indicated by the following illustration from a photograph of Mrs. Wm. M. Allison of Statesville, N. C., who had owned and operated one of these machines since 1860 and who says, in a letter dated 1911, that "it has stitched many hundred miles of seam and is still in good working order."



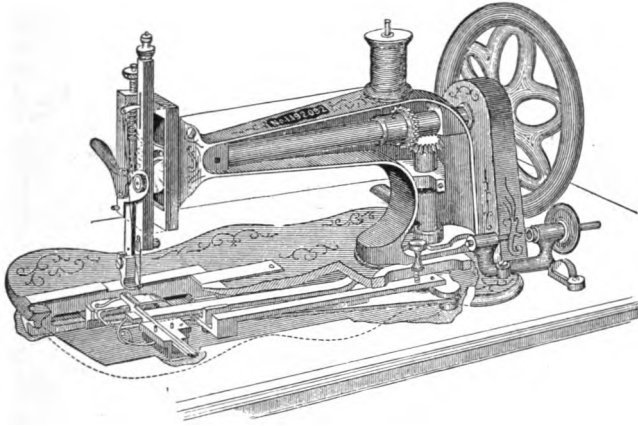

Singer Machine: "The New Family"

In 1865 the "New Family" was put on the market and had a large and wide distribution; more than four millions of this type were sold up to 1882 and it is still in demand in various countries of the world. The machine makes a lock-stitch by means of a straight eye-pointed needle and a longitudinally reciprocating shuttle. The needle-bar derives its motion from a pin on the end of a rotating horizontal main shaft, the pin entering a heart-shaped groove in a block attached to the needle-bar. A bevel gear on the main shaft, connects with a vertical shaft provided at its lower end with a crank, connected by link with the shuttle driver or carrier. The four-motion feed-dog is operated through the horizontal lever actuated from the vertical shaft. The feed is adjusted through a movable fulcrum, controlled by a set-screw. A take-up lever controls the thread between the tension device and the eye of the needle.

In 1867 a modification of the "New Family" called "No. 1 Drop Feed," was produced, and in 1870, the "Medium," an enlarged "New Family" was used extensively for light manufacturing.

The "Medium" machine, identical with the "New Family" except that it has more room under the arm (length of arm, 12 inches), was larger and designed for stitching heavier material.

The No. 4 machine was identical, except in size, with the "New Family" and "Medium." It had 15 inches length of overhanging arm and was made in response to the demand of clothing manufacturers for a machine for power operation.

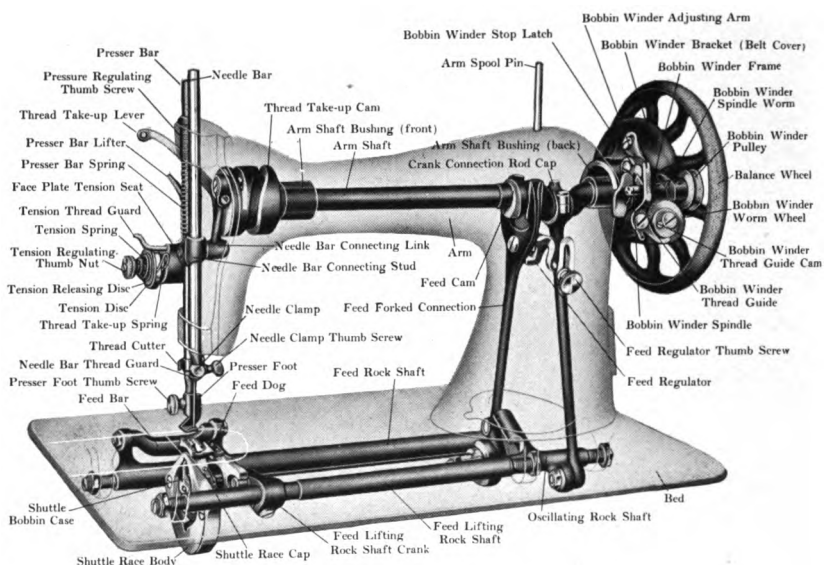

Singer Machine No. 15-30 Oscillating Shuttle

Mechanism of Machine No. 15-30, a modern variety of Oscillating Shuttle Machine for light fabrics. 1600 stitches per minute

In 1879 the "Oscillating Shuttle" mechanism was patented and this laid the foundation for the "Improved Family" (Class 15) and the "Improved Manufacturing" (Class 16) of to-day.

The scientific design of the oscillating shuttle machines marked the beginning of a new era in sewing mechanism. The utmost care is taken in the shaping, construction and "timing" of all the various parts so that the machines shall produce perfect stitching with the least expenditure of energy, the least noise of action, and the greatest number of stitches in a given time. The original principles have since been embodied in many types and varieties of Singer machines now on the market and in use in many lines of manufactures, where they are accepted as most efficient for their special purposes.

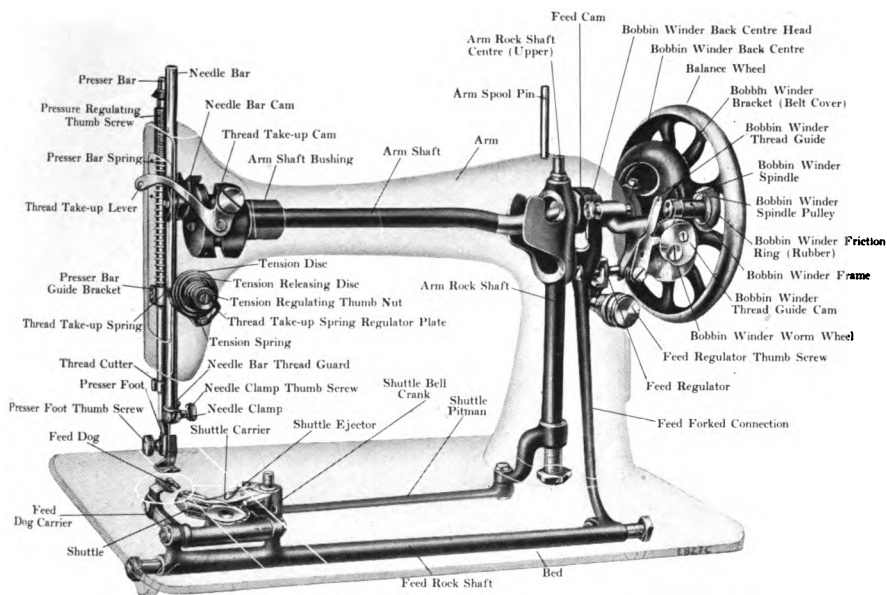

Singer Machine No. 127-3 Vibrating Shuttle

Mechanism of Machine No. 127-3, the V. S. Machine of to-day

The vibrating shuttle machine (V. S. No. 1) for foot power operation was patented in 1885 but was superseded by the V. S. No. 2, in 1887, which has been in vogue ever since, and millions of these machines are now in family use all over the world. They are distinguished for simplicity and strength of mechanism and are now known, in a modified form, as No. 127-3, illustrated above.

The vibrating shuttle is boat shaped and carries for cargo the bobbin containing the under thread.

It is illustrated on page 57.

It has a semi-circular movement or "throw" similar to a weaver's shuttle and makes a complete stitch at each movement in one direction, and is then carried back to begin the next stitch.

The stitch formation by this and other types of shuttles is illustrated and described on succeeding pages.

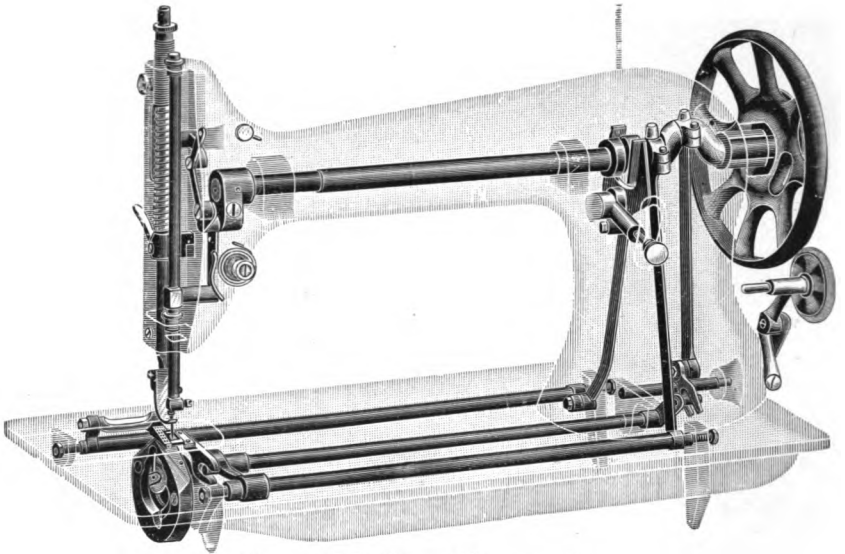

**Singer Machine No. 31-15
Oscillating Shuttle**

**Mechanism of Machine No. 31-15, the modern machine
for Clothing manufacture**

The above illustration shows the stitching mechanism of this machine, successfully combined to obtain the highest efficiency, and having a small number of moving parts, all capable of easy adjustment.

The link thread take-up consists of a light and strong lever and link, working silently, without use of cam or spring. A speed of 2,200 stitches per minute can be attained without undue vibration of the machine and with least friction and wear of parts.

The machines of this Class were introduced in the year 1895.

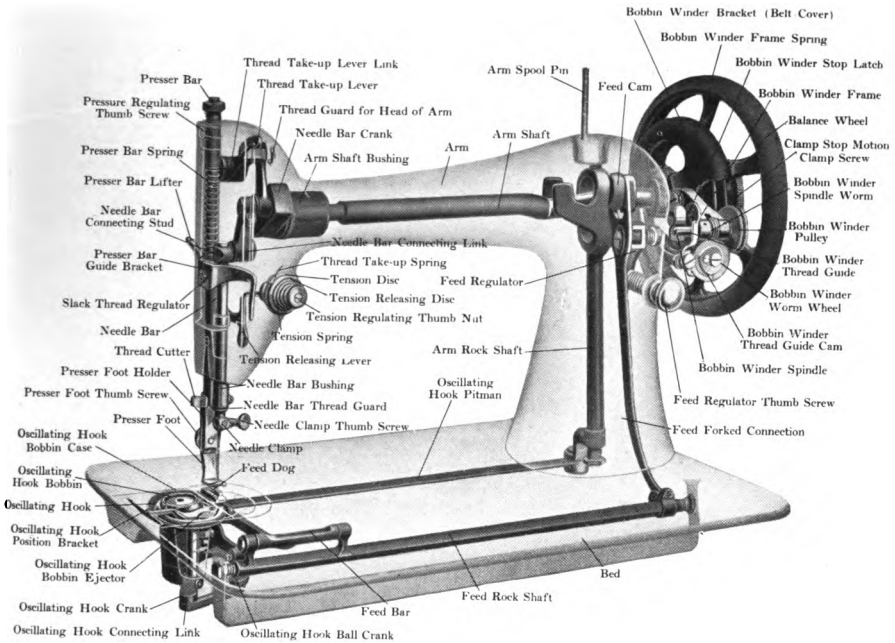

Singer Machine No. 66-1 Oscillating Hook

Mechanism of Machine No. 66-1

“The Singer 66,” for family sewing, was brought out in 1900 and has been fitly named **“the 20th Century Sewing Machine.”**

It has link take-up and concealed needle-bar; the central bobbin in its case lies at the top where it is easily accessible and the lower thread is handled by an oscillating hook.

The central bobbin hook is made from one solid piece of steel, hardened and polished; its simple and regular oscillation around the bobbin requires but little power and is efficient and economical for lock-stitch sewing machines. The central bobbin has capacity for 100 yards of No. 60 cotton, and its delivery of under thread to the material is perfect.

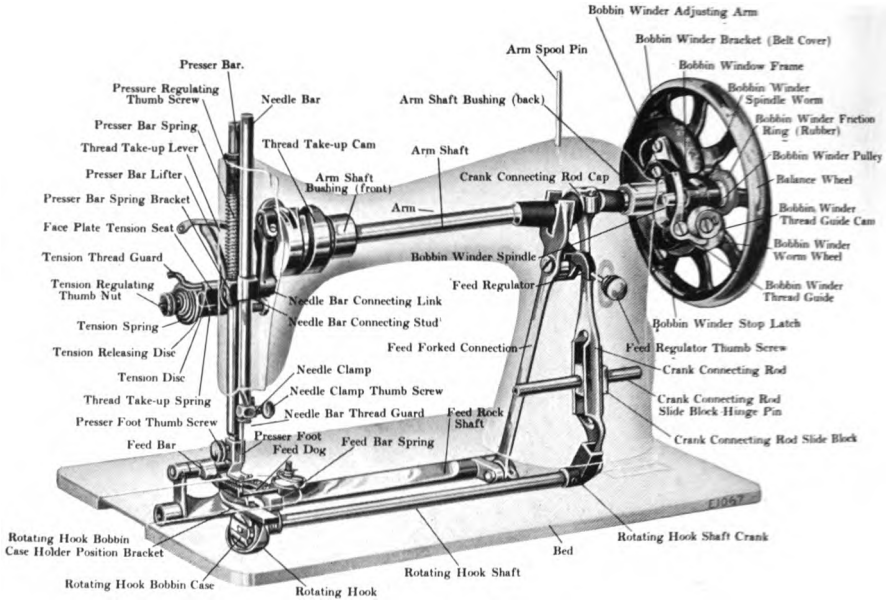

Singer Machine No. 115-1 Rotary Hook

Mechanism of Machine No. 115-1

The use of a continuous rotating hook for the lower thread in making the lock stitch was the invention of Allen B. Wilson, who was one of the most ingenious inventors in the sewing machine field of his day. His patent of Nov. 12, 1850, covered the invention of the moving feed-bar, having teeth projecting up through the horizontal cloth-plate on the bed of the machine, in conjunction with a presser-foot coming down on the material to be sewed, thus presenting it for action by the feed bar. His patents of Aug. 12, 1851 and June 15, 1852, for an improved feeding device, and for a revolving hook for passing the upper thread around the bobbin containing the under thread, gave to the world a feed that admits the sewing of a curved seam, while the revolving hook is a marvelous piece of ingenuity and mechanical skill. The essential principles of his inventions are used in all of the rotary hook machines of to-day.

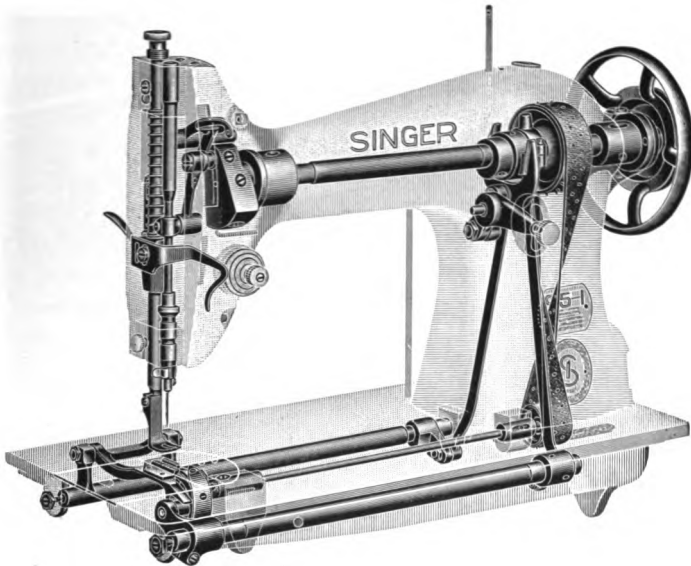

**Singer Machine No. 95-1
Rotating Hook**

**Mechanism of Machine No. 95-1, the modern high-speed lock-stitch Machine
for light fabrics, 3,500 stitches per minute**

This machine, for power operation only, has a rotating hook with stationary bobbin case enclosing the bobbin; the hook is carried upon the end of a small shaft driven by a belt from the arm shaft and operates without any friction; the outside of the hook is always perfectly clean and no work can be injured by soiled thread; the machine sets firmly and without vibration on the table, the stitch is firm and even and produced with comparatively light tensions upon both upper and under threads.

This machine was placed on the market in 1911.

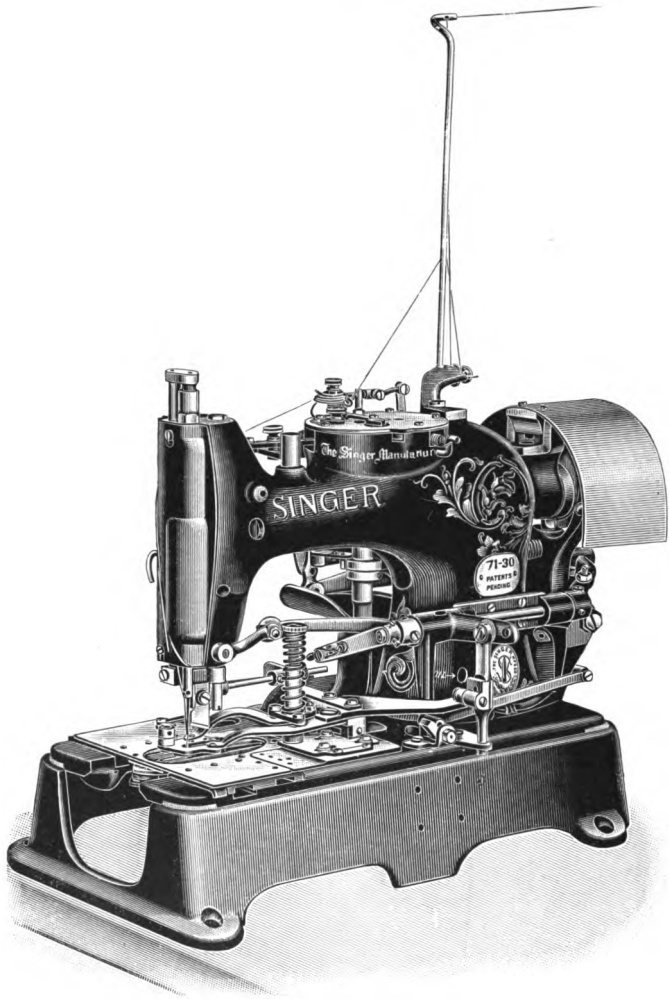

Singer Machine No. 71-30

Machines of Class 71, for power operation, were brought out in 1904 and are the latest evolution for making straight buttonholes without eyelets, either purl-stitch or whip-stitch.

They are especially designed for work on Cotton and Linen Fabrics and Knit Goods; they excel all other machines, not only in the quantity of work produced, but also in the neatness of the finish and the facility with which adjustments can be made. While truly automatic, they are simple and effective, not liable to get out of order, and are easily handled by all operators.

It will be seen from the preceding description and illustrations, that the basic mechanisms now in use for making the lock stitch comprise a vertically moving bar carrying an eye-pointed needle for the upper thread, and either a vibrating shuttle or an oscillating or a rotating hook for the lower thread taken from a bobbin, and that the means for operating them vary widely according to the duty required.

The shuttles for carrying the bobbins containing the lower thread were, at first, modeled after the weaver's shuttle and were boat-shaped. The movement or "throw" of this form of shuttle is usually horizontal, either on a straight line or having a curved throw, the first being exemplified in the "New Family" and the latter in **Machine No. 127-3**.

The "oscillating shuttle," **Machine No. 15-30**, stands vertically and oscillates around a central bobbin enclosed in a removable case, while the "oscillating hook," **Machine No. 66-1**, stands horizontally and its bobbin is more easily accessible. The "rotary hook," **Machine No. 115-1**, stands vertically and rotates around a central bobbin. The shuttles and bobbins, also the formation of the stitch by the respective machines, are illustrated and described as follows:

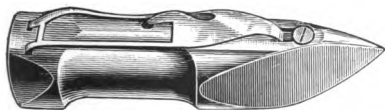

Vibrating Shuttle, for Machine No. 127-3

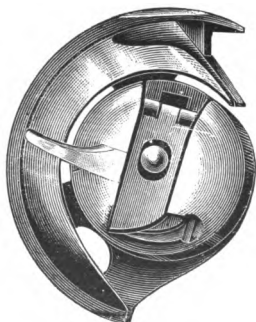

Oscillating Shuttle and Central Bobbin in its case

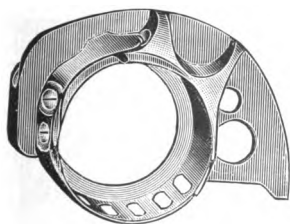

Oscillating Hook, for Machine No. 66-1

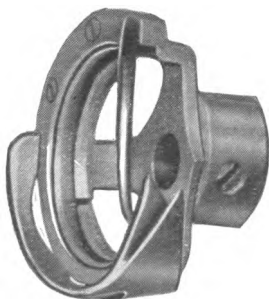

Rotary Hook, for Machine No. 115-1

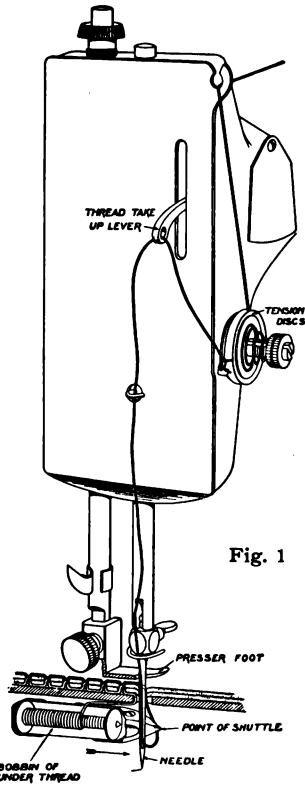

Fig. 1

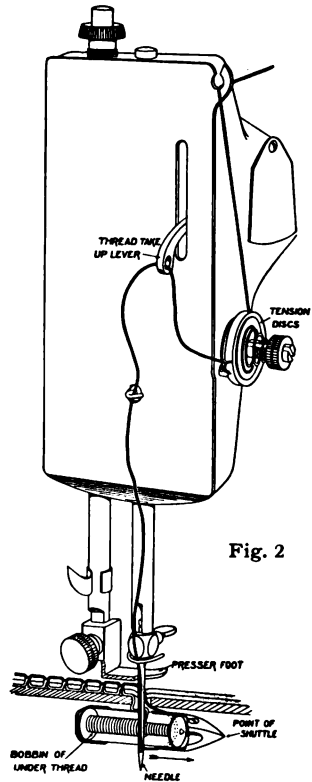

Fig. 2

VIBRATING SHUTTLE

Point of Shuttle Entering Loop of Needle Thread

Fig. 1 shows the first stage in stitch formation. The thread leading to the needle is loosened, because the thread take-up lever has begun its descent; the needle, after having descended to its lowest point, has been slightly raised and a loop of thread is thus formed which is immediately entered by the point of the shuttle.

Shuttle in Loop of Needle Thread

Fig. 2 shows the second stage. The shuttle containing the bobbin of under thread, has fully entered the loop of needle thread, sufficient enlargement of the loop having been permitted by the descent of the thread take-up lever.

The shuttle travels to and fro in a carrier to which it is not fastened, but by which it is held in position. During the forward movement of the shuttle the loop of needle thread slips between the shuttle and the carrier, then passes out between the heel of the shuttle and the rear part of the carrier. The shuttle thread is thus enclosed in the loop of needle thread and both threads are then drawn up by the action of the thread take-up lever.

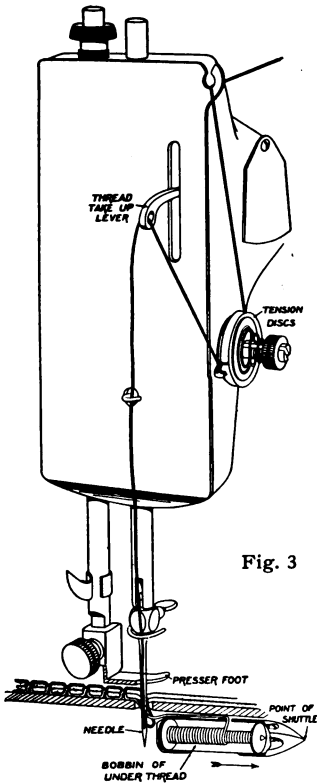

Fig. 3

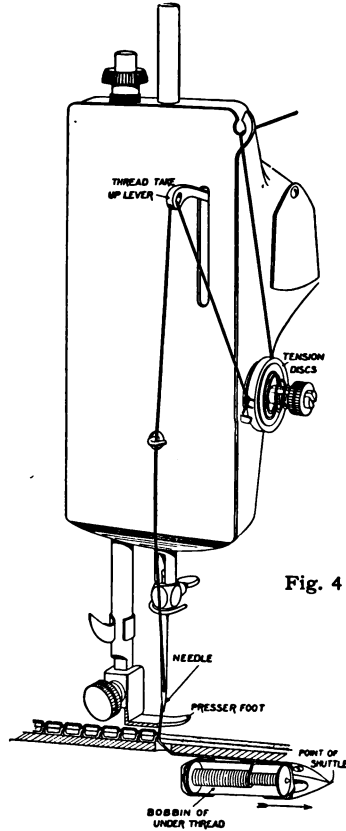

Fig. 4

VIBRATING SHUTTLE

Shuttle Thread Enclosed by Needle Thread

Fig. 3 shows the third stage. The shuttle has passed through the loop of needle thread, the shuttle thread has been enclosed by the needle thread, and the thread take-up lever is being raised to tighten the stitch.

Stitch Completed

Fig. 4 shows the stitch completed. The thread take-up lever has been raised to its highest point, drawing the needle thread, together with the shuttle thread, into the middle of the fabric, the two threads now being locked. The tension on the needle thread is regulated by the circular tension discs shown in the illustrations, and the tension on the under thread is regulated by a spring on the shuttle.

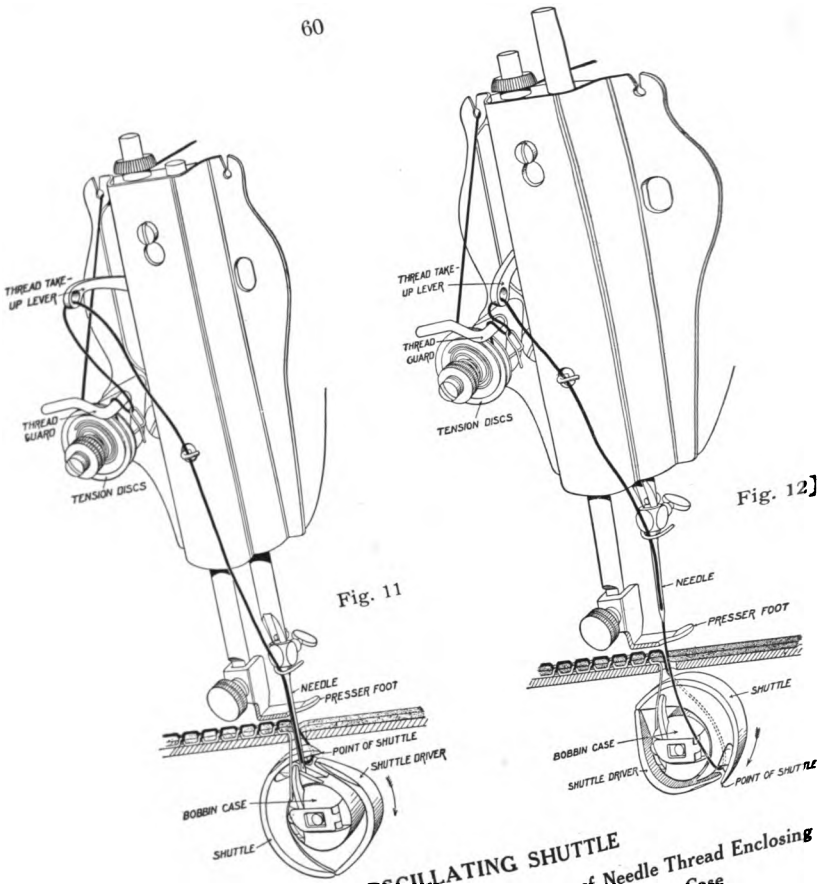

Fig. 11

Fig. 12]

OSCILLATING SHUTTLE

Point of Shuttle Entering Loop of Needle Thread

Fig. 11 shows the first stage in stitch formation. The thread leading to the needle is loosened, because the thread take-up lever has begun its descent; the needle, after having descended to its lowest point, has been slightly raised and a loop of thread is thus formed which is immediately entered by the point of the shuttle. The oscillating shuttle makes part of a revolution during the beginning of each stitch, the direction being indicated by the arrows in Figs. 11 and 12, and during the completion of the stitch the direction of the shuttle is reversed as shown by the arrows in Figs. 13 and 14.

Loop of Needle Thread Enclosing Bobbin Case

Fig. 12 shows the second stage. The loop of needle thread has been taken down by the point of the shuttle and is being passed around the bobbin case containing the bobbin of under thread, sufficient enlargement of the loop having been permitted by the descent of the thread take-up lever.

CONFIDENTIAL REPORT

Under the provisions of

Section 105(c)

Section 105(c)

The following information was obtained from a confidential source who has provided reliable information in the past. The source has provided information concerning the activities of the [redacted] in the [redacted] area. The source has provided information concerning the activities of the [redacted] in the [redacted] area. The source has provided information concerning the activities of the [redacted] in the [redacted] area.

The following information was obtained from a confidential source who has provided reliable information in the past. The source has provided information concerning the activities of the [redacted] in the [redacted] area. The source has provided information concerning the activities of the [redacted] in the [redacted] area. The source has provided information concerning the activities of the [redacted] in the [redacted] area.

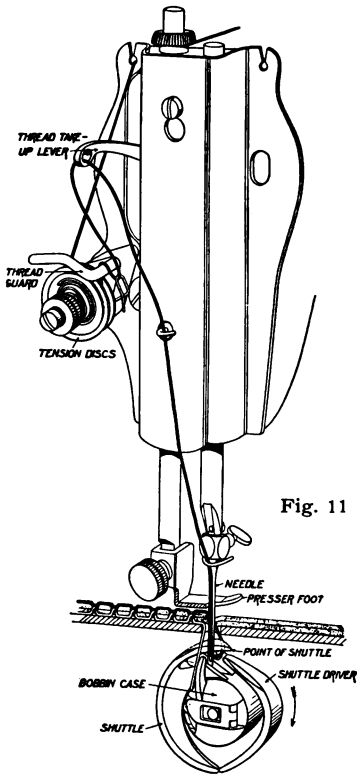

Fig. 11

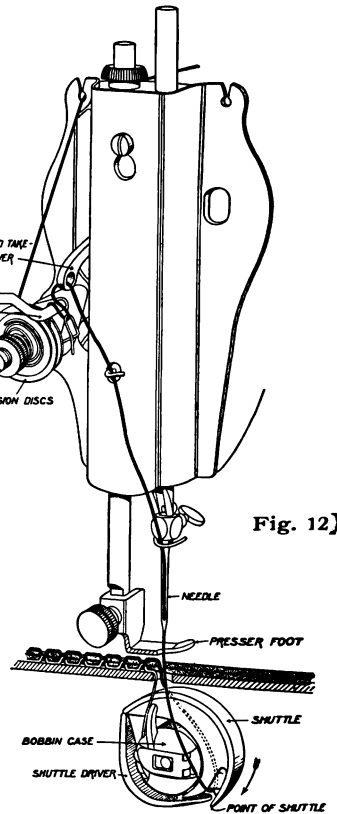

Fig. 12]

OSCILLATING SHUTTLE

Point of Shuttle Entering Loop of Needle Thread

Fig. 11 shows the first stage in stitch formation. The thread leading to the needle is loosened, because the thread take-up lever has begun its descent; the needle, after having descended to its lowest point, has been slightly raised and a loop of thread is thus formed which is immediately entered by the point of the shuttle. The oscillating shuttle makes part of a revolution during the beginning of each stitch, the direction being indicated by the arrows in Figs. 11 and 12, and during the completion of the stitch the direction of the shuttle is reversed as shown by the arrows in Figs. 13 and 14.

Loop of Needle Thread Enclosing Bobbin Case

Fig. 12 shows the second stage. The loop of needle thread has been taken down by the point of the shuttle and is being passed around the bobbin case containing the bobbin of under thread, sufficient enlargement of the loop having been permitted by the descent of the thread take-up lever.

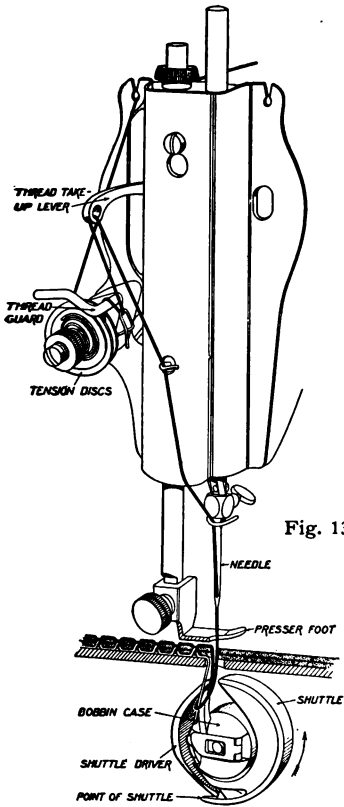

Fig. 13

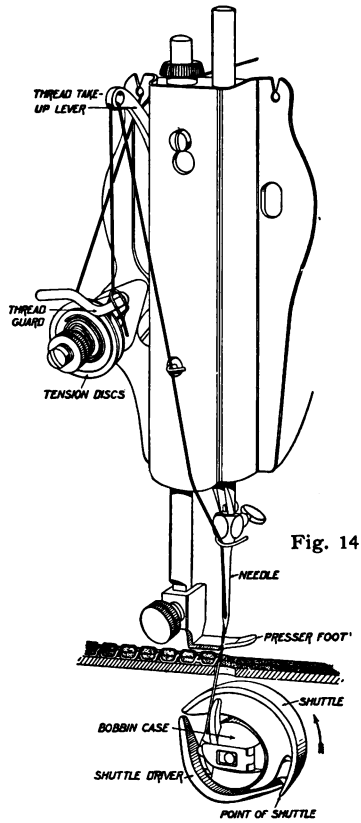

Fig. 14

OSCILLATING SHUTTLE

Under Thread Enclosed by Needle Thread

Fig. 13 shows the third stage. The loop of needle thread has been cast off from the shuttle, the under thread has been enclosed by the needle thread, and the thread take-up lever is being raised to tighten the stitch.

Stitch Completed

Fig. 14 shows the stitch completed. The thread take-up lever has been raised to its highest point, drawing the needle thread, together with the under thread, into the middle of the fabric, the two threads now being locked. The tension on the needle thread is regulated by the circular tension discs shown in the illustrations, and the tension on the under thread is regulated by a spring on the bobbin case.

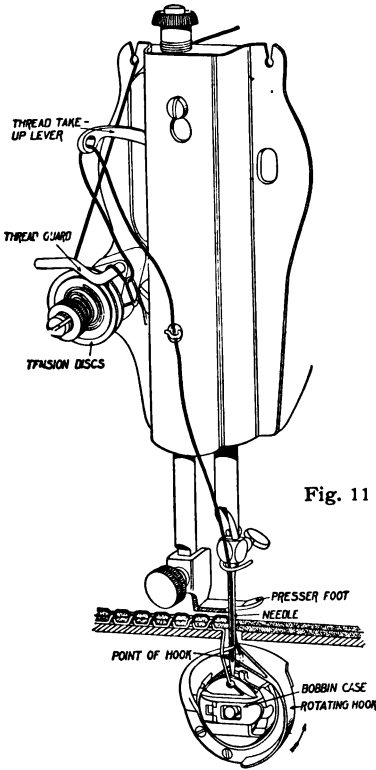

Fig. 11

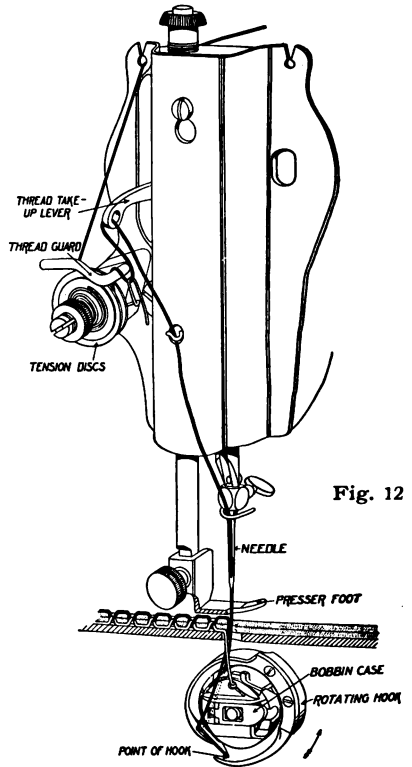

Fig. 12

ROTARY HOOK

Point of Hook Entering Loop of Needle Thread

Fig. 11 shows the first stage in stitch formation. The thread leading to the needle is loosened, because the thread take-up lever has begun its descent; the needle, after having descended to its lowest point, has been slightly raised and a loop of thread is thus formed which is immediately entered by the point of the hook, which rotates in one direction around the stationary bobbin case.

Loop of Needle Thread Enclosing Bobbin Case

Fig. 12 shows the second stage. The loop of needle thread has been taken by the point of the hook and is being passed around the bobbin case, sufficient enlargement of the loop having been permitted by the descent of the thread take-up lever.

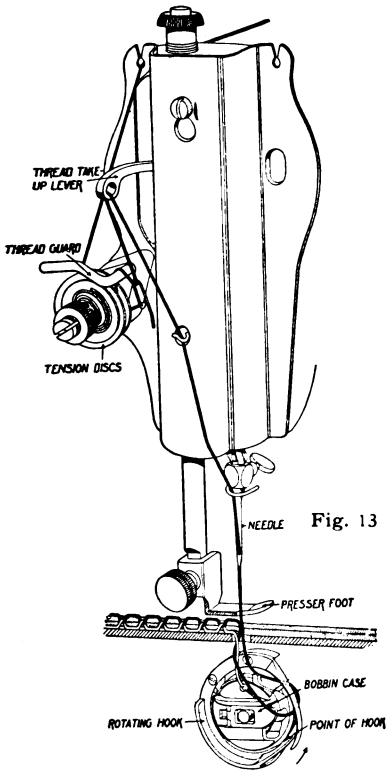

Fig. 13

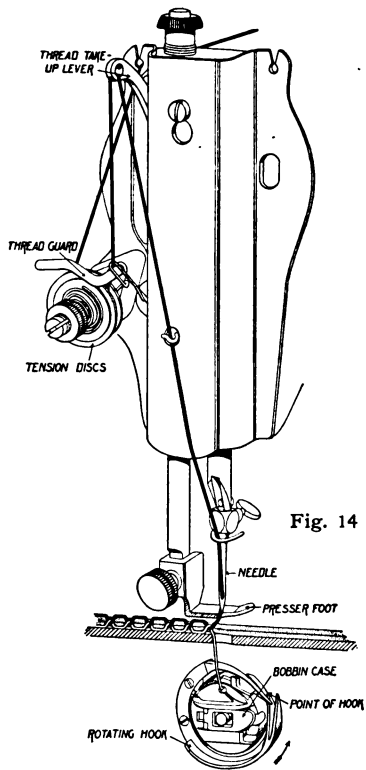

Fig. 14

ROTARY HOOK

Under Thread Enclosed by Needle Thread

Fig. 13 shows the third stage. The loop of needle thread has been cast off from the hook, the under thread has been enclosed by the needle thread, and the thread take-up lever is being raised to tighten the stitch.

Stitch Completed

Fig. 14 shows the stitch completed. The thread take-up lever has been raised to its highest point, drawing the needle thread, together with the under thread, into the middle of the fabric, the two threads now being locked. The tension on the needle thread is regulated by the circular tension discs shown in the illustrations, and the tension on the under thread is regulated by a spring on the bobbin case.

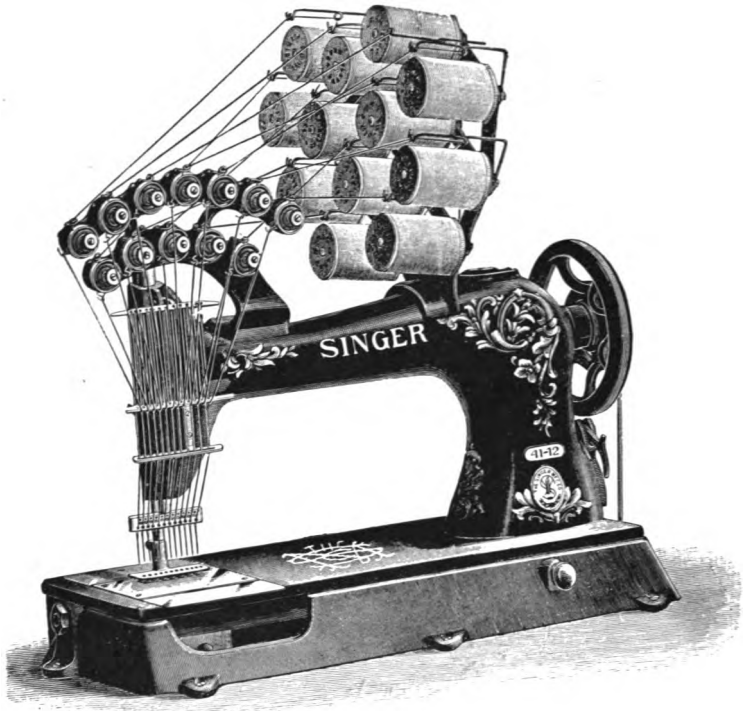

Singer Machine No. 41-12

Multiple Needle Sewing Machines

There are Singer Machines for making from two to twelve parallel rows of stitching at one operation.

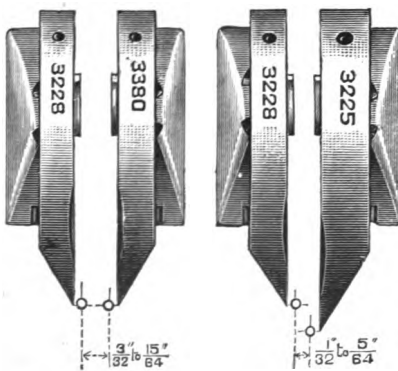

Shuttles for Different Gauges
on Two-Needle Machines

The relative position and style of the oscillating shuttles used on the two-needle machines are shown in the illustrations herewith.

On machines carrying from three to twelve needles the spacing of the needles may be arranged as desired within a limit of $2\frac{13}{32}$ inches, the extreme distance between outside shuttles.

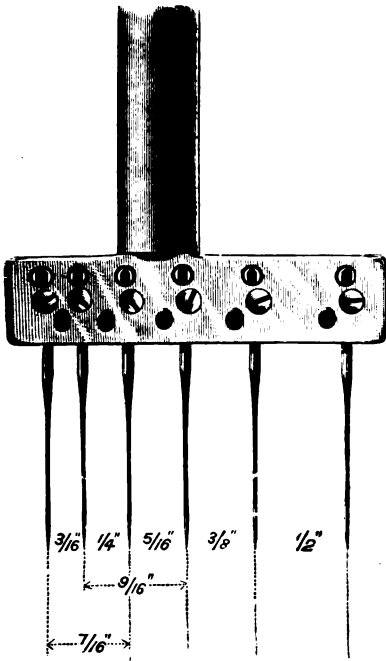

Spacing of Needles on Singer
Machine No. 41-6

thread through center of shuttle, thus securing central delivery of thread until the cops are entirely unwound and used.

Reference to the illustration will show that these machines are capable of a number of changes in distance between the rows of stitching without other adjustment than a simple change of needle.

The least distance between the points of two shuttles is $\frac{3}{16}$ inch and, for obvious reasons, it is essential that the shuttles on these machines shall be as thin as possible. They cannot, therefore, contain a bobbin for the under thread, and this thread is carried in ready-wound cops that fit tightly into the shuttles as shown in the illustration below.

These cops unwind from their outer edge and deliver

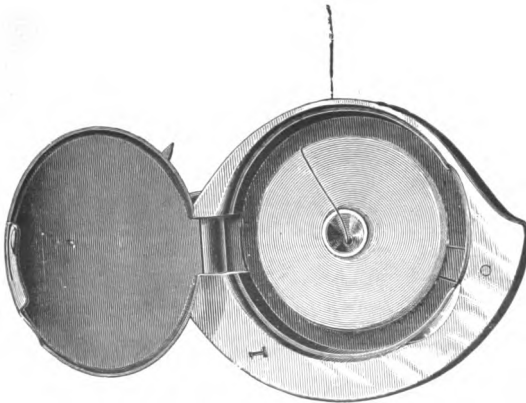

Shuttle for Multiple Needle Machines of Class 41

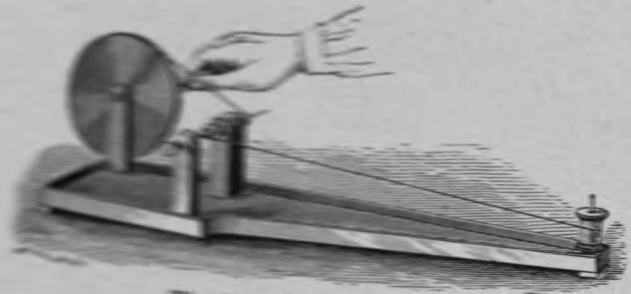

The First Bobbin Winder

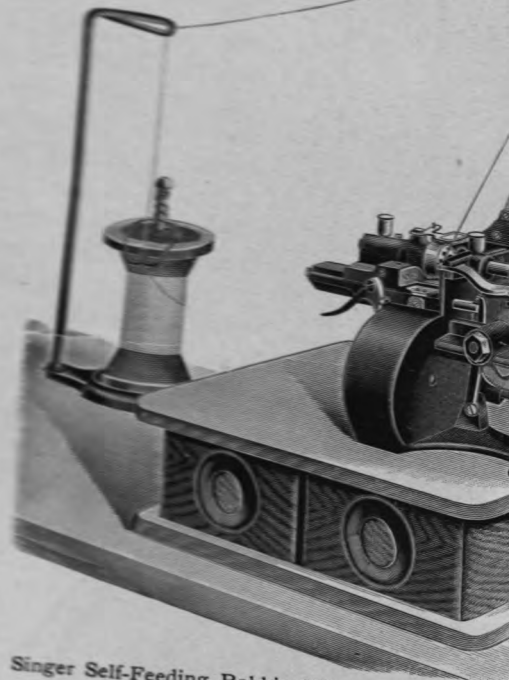

Singer Self-Feeding Bobbin Winder No. 27738

This machine is thoroughly automatic in its operation and requires no attention except to keep the hopper full of bobbins. Bobbins of various sizes for Singer and other makes can be placed together in the hopper, the machine feeding and filling them indiscriminately. The machine winds the

the end thread, releases the take-up bobbin, which drops into a trough beneath the machine and, fast is so arranged, the process being repeated as long as the bobbins are shown are supplied. By the use of this machine, a supply of filler bobbins can constantly be kept in readiness for a large number of operatives, and a great saving of time is thereby effected.

A technical study of the distinctive mechanism shown in the foregoing illustrations of the evolution of the sewing machine will be of interest and value to the teacher of Physics in the department of mechanical construction. Technical illustrations and description of any of the component parts will be furnished for school use upon application to Singer Sewing Machine Co., Room 810, Singer Building, New York City.

The following example of cam illustration and description relates to a machine for attaching buttons to clothing.

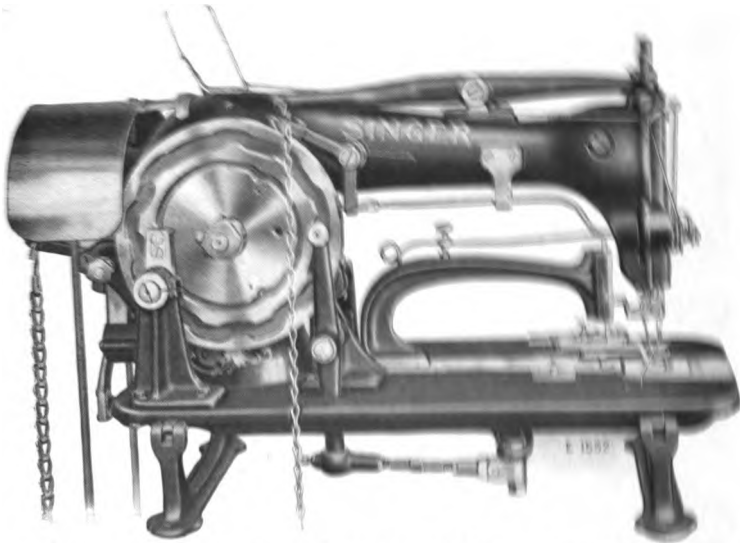

One of the important features of this machine is the well made multiple cam which has many functions to perform. By its control of the clamp the needle is enabled to enter the separate holes in the buttons; it operates the thread cutting mechanism and the thread nipper mechanism, and automatically stops the machine when the button has been stitched. The cam is accurately cut by automatic machines which makes great precision possible.

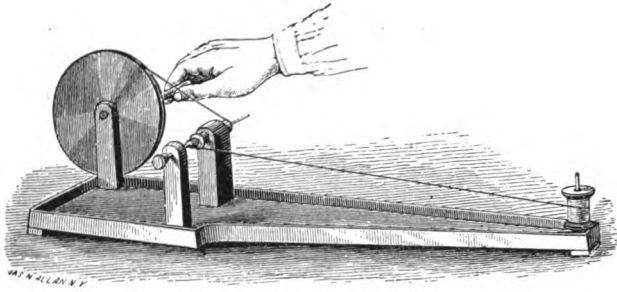

The First Bobbin Winder

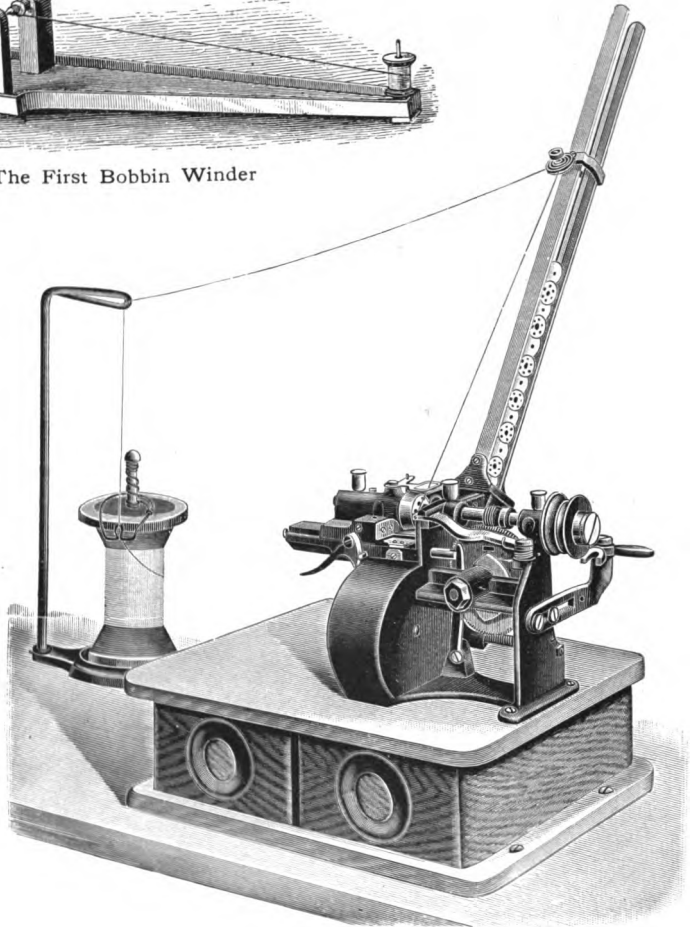

Singer Self-Feeding Bobbin Winder No. 27738

This machine is thoroughly automatic in its action, and requires no attention except to keep the hopper filled with bobbins. Bobbins of various sizes for Singer and other machines can be placed together in the hopper, the machine feeding and filling them indiscriminately. The machine winds the bobbin,

cuts the thread, releases the filled bobbin, which drops into a drawer beneath the machine, and feeds in an empty one, this process being repeated as long as the bobbins and thread are supplied. By the use of this machine a supply of filled bobbins can constantly be kept in readiness for a large number of operatives, and a great saving of time is thereby effected.

A technical study of the distinctive mechanisms shown in the foregoing illustrations of the evolution of the sewing machine will be of interest and value to the teacher of Physics in the department of mechanical construction. Technical illustrations and description of any of the component parts will be furnished for school use upon application to Singer Sewing Machine Co., Room 310, Singer Building, New York City.

The following example of cam illustration and description relates to a machine for attaching buttons to clothing.

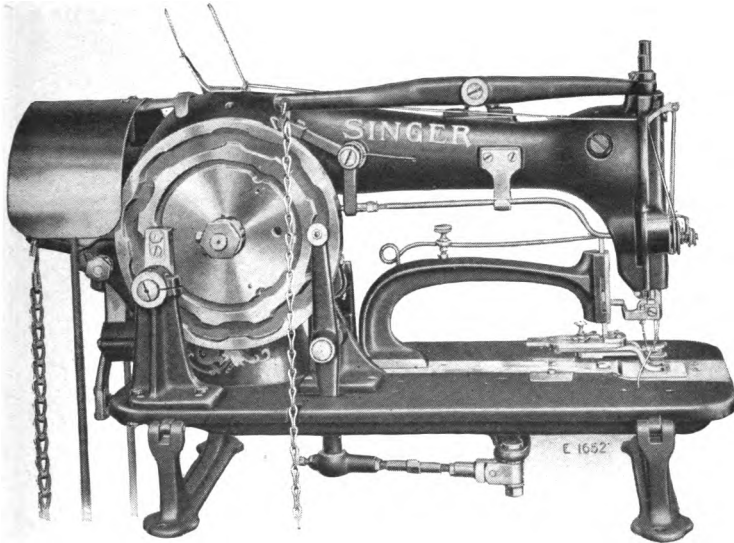

One of the important features of this machine is the well-made multiple cam which has many functions to perform. By its control of the clamp the needle is enabled to enter the separate holes in the buttons; it operates the thread cutting mechanism and the thread nipper mechanism, and automatically stops the machine when the button has been stitched. The cam is accurately cut by automatic machines which makes great precision possible.

The Sewing Machine as a Means for Productive Industry in the Home

No mechanical invention has ever approached the usefulness of the sewing machine in Home Economics. Most women should be so familiar with the use of the family sewing machine as an essential tool for economy in the home in the making of garments, the mending of stockings, and of table and bed linen, in embroidering and the making of a great variety of fancy articles, that it seems unnecessary to enlarge upon a trite subject.

Some of the Singer machines can be used in the home quite as well as in the factory, especially if electric power be available, and a brief description of two of these may be of interest.

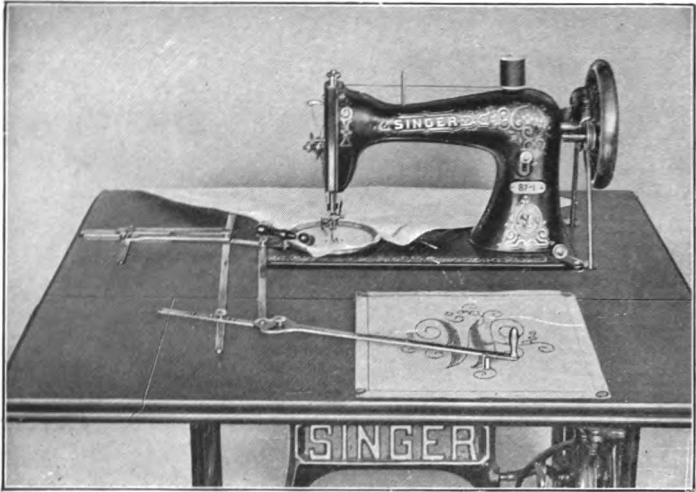

Singer Machine No. 87-1, on Stand No. 25370, Table No. 5439

For Embroidering Initials, Monograms, Crests, Labels, Floral Designs and figures in overcast or other embroidery stitches, the regular "round-bobbin" Singer machine for family sewing has been fitted with a "pantograph" attachment, the whole outfit costing \$48.00.

The fabric is fastened in a hoop attached to a pantograph frame, by means of which both fabric and hoop are moved under the needle in any direction, following the pattern stitch by stitch, and in exact proportion, under the tracing point of the pantograph.

In using this machine, the operator sits at the table and moves the tracing point of the pantograph so that it follows the lines of the pattern. This causes a corresponding movement of the work in the hoop. As the pattern is from three to eight times the size of the finished work, it is easy for the operator to follow it closely with the tracing point.

Friction Transfer Embroidery Patterns are best for quick transfer because they require no hot iron, simply the pressure of any smooth, hard substance over the paper transfers pattern to the material. Several transfers can be taken from the same pattern. Eight sheets, each measuring 18 x 24 inches, constitute a set comprising a sufficient variety of patterns for most requirements, will be furnished to schools for 25 cents per set mailed to Singer Sewing Machine Co., Room 310, Singer Building, New York.

Machine No. 72 w 19 for Hemstitching

This machine is fitted for two-needle hemstitching on shirt waists, underwear, handkerchiefs, ladies' neckwear, etc. The openings are $\frac{1}{16}$ inch and the stitch is known as the over-edge hemstitch, the two hemstitch sides of the opening being overseamed.

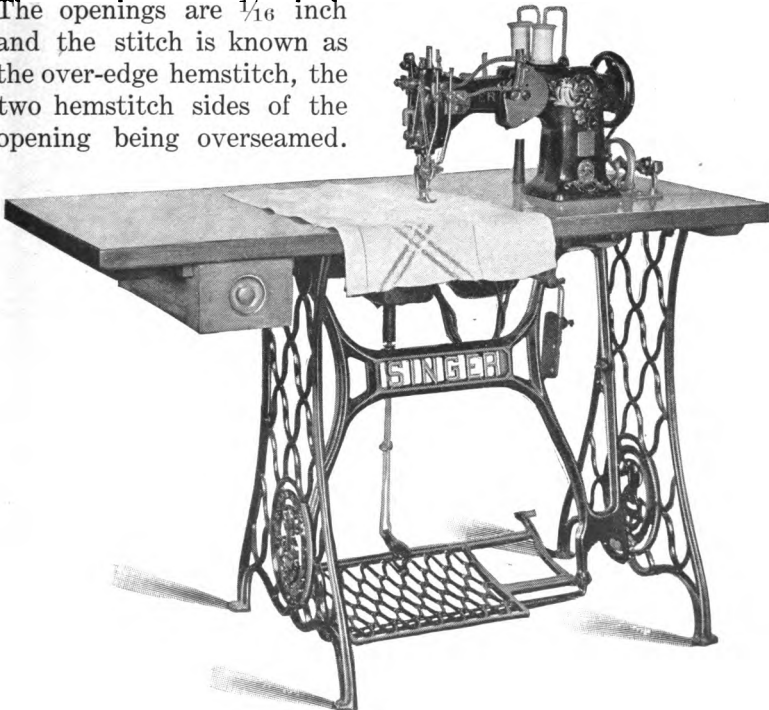

Attachments can be furnished for use with the machine for automatically guiding and hemming any desired width of material, also for tucking, stitching on lace, plaiting, etc. For ease of operation and for quality and quantity of production, the Singer machines of this class are unequalled.

The illustration shows the machine on table and stand equipped with a $\frac{1}{4}$ horse power direct-current **Diehl** motor, enabling the machine to be driven at varying speeds up to 1300 stitches per minute.

Its cost in New York, equipped as described, is \$157.50. If furnished on foot treadle stand its cost is \$132.50.

A power machine will easily earn for its operator, on the usual varieties of custom work, \$60 per week. This has been demonstrated by practical experience in various cities.

No unusual experience is required to operate this machine. Any sensible woman can readily become sufficiently expert in a short time properly to accomplish any work that may be presented. There has been a steady demand for hemstitching for so many years that it may fairly be considered as stable and permanent.

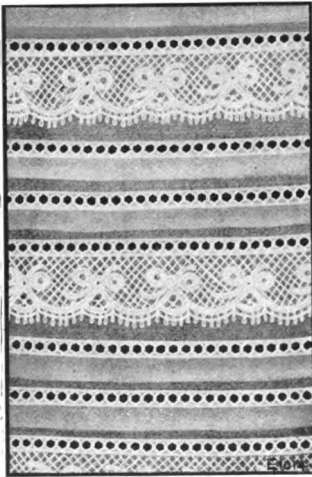

Sample of Work of Machine No. 72 w 19. Piercer No. 213825. Side Plaiting.

Tucks formed with the Plaiter and the goods hemstitched at one operation. Lace stitched to the goods and the hemstitch made at one operation.

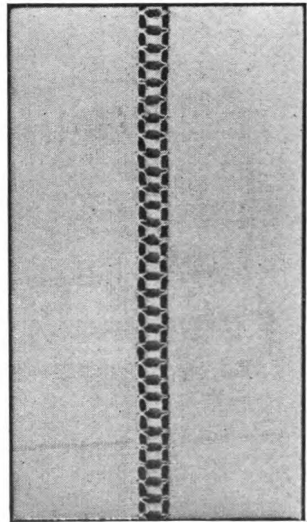

Sample of Work of Machine No. 72 w 19, with cord overstitched on each side of the opening

Special Tools

One of the most important departments of the modern Singer factory is that for designing and constructing the tools required accurately to make the thousands of different kinds of sewing machine parts so that every one of a kind shall be exactly duplicate and interchangeable with its fellow.

Since the first application of the fundamental principles of the Singer sewing machine, its development has been on lines to meet the demand for diversified applications and uses.

New combinations of old principles; improvements in the details of design and construction—these are constantly occurring. The ingenuity displayed by an inventor frequently has no value whatever until some equally bright mind is able to plan a way by which the invention can be made commercially available.

Each variety of sewing machine has its peculiar parts requiring special tools for their manufacture; these tools are devised and built at the Singer works and display great originality and ingenuity. The development of labor-saving machine tools for making labor-saving sewing machines is carried to its utmost limit here, and the high efficiency and durability of Singer sewing machines are largely due to this basis of originality in the process of their construction.

The Singer Gauge System

The manufacture of articles by the use of machines specially designed for the production of each component part, the various parts being subsequently "assembled" to form the finished product, was first carried out on a large scale in the United States. It is still generally known throughout the world as "the American system."

With the advancement of mechanical art through the general use of machine tools, absolute precision in the execution of its processes was made possible. But the assembling system requires this perfect accuracy to be exactly uniform on each piece. In order to preserve a perfect uniformity of the dimensions of each corresponding part, it is necessary to use gauges that shall test the truth of each, as compared with its standard,

to such a minute fraction that it seems hardly possible for the senses to detect it.

Such gauges are systematically and rigidly used at every point in the construction of a Singer sewing machine, and each part is numbered.

Singer parts always fit and they can be readily obtained at Singer shops located in every city in the world.

The Specialization of Singer Machines

The increased use of sewing machines in American factories, with greater sub-division of the work, is due to experience which has taught manufacturers that by sub-dividing the work on machines they can utilize inexperienced help. A girl that can do nothing but run a sewing machine can be taught in a day or two to stitch one particular part, and in a few months she will become more expert in doing that part than would an all-around operator, with years of experience, in doing a set or series of operations.

Hardly a week passes without a demand from some manufacturer for a machine to perform some special duty or stitching process and this has resulted in the creation of, not only hundreds of distinct types or classes of Singer machines, but no less than 2,356 "varieties" or modifications of these "classes" to meet these special requirements.

A machine that is well devised to do a definite work will perform it better than one having possible application to many varieties of work, and for this reason Singer Sewing Machines have been specialized so that each shall be the best for its own purpose. This development of special stitching appliances for use in the factory has been not only of tremendous benefit to the world at large, by causing a great reduction in the cost to the consumer, but it has brought commercial success to the manufacturer, who could not have achieved modern results without these special sewing machines.

The practical results of this specialization are indicated by the list of industries shown on the next page:

NAME OF INDUSTRY— GOODS MANUFACTURED	Number of Estabs.	Number of Sewing Machines	NAME OF INDUSTRY— GOODS MANUFACTURED	Number of Estabs.	Number of Sewing Machines
Aprons.....	103	1709	Gloves and mittens...	809	22085
Awnings.....	679	5137	Handkerchiefs.....	105	6332
Bags, oil press.....	554	637	Harness and saddlery..	851	3638
“ other than oil press.....	321	3568	Horse clothing.....	61	1251
Belting, leather, rubber and canvas.....	60	599	Infants' wear.....	109	4695
Books and pamphlets..	363	781	Knit goods.....	864	34889
Buffing wheels.....	34	313	Leather goods.....	392	2882
Buttonholes.....	107	833	Leggins and overgaiters	36	1177
Canvas goods.....	58	419	Mackintoshes a n d rubber clothing.....	87	2414
Caps and hats.....	550	8800	Mattresses and bedding	619	3919
Carpets and rugs.....	1687	4975	Millinery (factories only).....	350	4371
Carriages and autos...	813	3416	Neckwear (men's)....	249	3306
Carriage trimming....	35	323	Novelties (ladies' neck- wear, etc.).....	556	13187
Casket trimming.....	106	1191	Rubber goods.....	89	1826
Cloaks and suits.....	1567	38359	Sheets and pillow cases	22	1012
Clothing, general.....	2444	43201	Shirts.....	1047	55118
“ coats.....	686	10565	Shoes.....	1621	67751
“ pants.....	587	12003	Skirts.....	798	19170
“ vests.....	228	3194	“ silk and petti- coats.....	169	7194
“ knee pants..	91	2355	Sporting goods.....	73	2062
“ children's... 124	2944		Suspenders.....	189	4175
“ rough—over- alls.....	780	32654	Umbrellas and parasols	143	1447
Clothing, rough—work shirts.....	210	24736	Underwear (men's)....	535	27261
Clothing, oiled.....	22	1456	Uniforms and regalias.	64	1573
“ misses and children.....	227	7578	Upholstery.....	279	1235
Collars and cuffs.....	98	10189	Waistbands.....	8	620
Corsets.....	178	11937	Waists.....	899	52790
Curtains.....	127	4083	Window shades.....	235	829
Dressmaking (factories only).....	391	7533	Wrappers.....	399	11370
Furs.....	171	1473	Miscellaneous (n o t classified).....	1478	11809

Sewing Machine Motors

The sewing machines prior to Singer had no arrangement for applying power for driving them except the common hand-crank. This required the use of the right hand, and only the left hand could be used for arranging and guiding the material to be sewed. The machines were put on a bench or table of home construction. Mr. Singer, in traveling about exhibiting his original machine, utilized the box in which it was packed for shipment as a table, and conceived the idea of using a treadle similar to that employed on the old spinning wheel, and having a pitman attached to the handle on the driving gear to assist him in working the machine. He used an ordinary door hinge as a fulcrum for the treadle, which was longer than the depth of the box and projected therefrom. He therefore placed the hinge about where the instep of the foot would be, and attached the other half of the hinge to the box, and thus found that he had a rocking motion on the treadle that aided in securing uniform motion to the machine. He soon discovered that, with the addition of a balance wheel on the upper shaft for increasing the momentum when the machine was once in motion, he could run it by foot power with his rocking treadle, operated by heel-and-toe motion, and so have the use of both hands for guiding and arranging the material. This was a great gain in utilizing the machine, and he soon after produced an iron stand having a rocking treadle constructed for the use of both feet. Mr. Singer did not realize that he had made a great and important discovery, and failed to apply for a patent. He was very much chagrined after having used the invention for two years and thus debarring himself from a patent, to be informed of his oversight by a rival manufacturer.

During the first twenty years of sewing machine exploitation more than seventy-five patents were granted for a great variety of motors, the principal proportion of them comprising various arrangements of coiled steel springs.

All of them have long since become obsolete and the ideal motive power is now found in the use of electrical current.

The Diehl Electric Motor



REAR VIEW

The Diehl Electric Motor for individual sewing machines consists of a supporting bracket carrying the motor, which is provided with a speed regulator and brake; to the bracket is attached a swinging arm on which is an "idler pulley." The bracket can be readily attached to any Singer Cabinet Table stand, in place of the band wheel; the motor pulley and idler are placed so that the belt passes to the head of the machine through the regular belt holes and no cutting of the table is required. The swinging arm carrying the idler keeps a uniform tension of the belt when running.

The machine head can be lowered and the table closed without removing or changing the belt in any way, the belt at the same time remaining on the pulley and in proper position when the head is again raised to the operating position.

The motor runs only when the machine is operated. No current is consumed by the motor except when actually doing work, when its cost is about the same as for the ordinary incandescent lamp.

The speed regulator, switch and brake are contained within the motor and are all operated by a single chain connected to the treadle, the brake acting on the motor pulley. Foot pressure on the treadle starts the machine instantly, while release of pressure cuts off the current and throws on the brake so that the machine stops at once.

At full speed the motor operates the machine at about 900 stitches per minute. The usual number of stitches made with a treadle machine is from 200 to 400. The speed can be varied at will by increased or decreased pressure on the treadle.

Mounting the motor on the brace of the machine stand secures greater stability than if placed on the table top, where the slightest tendency to vibration is greatly magnified. Mounting under the table keeps all parts out of the operator's way, so that the motor does not interfere with the work and is not so unsightly as one mounted on top of the table.

For the factory operation of sewing machines there are ingenious devices for their stable support on tables which are made in sections, each 4 feet long, carrying the shafting beneath, and so arranged as to be readily connected longitudinally as desired, and adjustable to any unevenness of floor. These tables are made for the operation of one or two rows of machines from one line of shafting, connected directly to the motor, all being carried beneath the tables where it can easily be adjusted. The tables have a thick wooden top that may be entirely flat, or they can be made with convenient work-holding troughs. In point of convenience, cleanliness, safety and economy, these tables leave nothing to be desired, for they seem to satisfy all requirements in these respects.

“Safety First.” The Singer Manufacturing Company is now engaged in perfecting the construction of tables for use in the power operation of sewing machines in factories.

These tables are illustrated on the following pages and they are especially designed to reduce the danger of personal accident to a minimum, thus lessening employers' liability and the cost of casualty insurance.

Singer Safety Tables for Factories

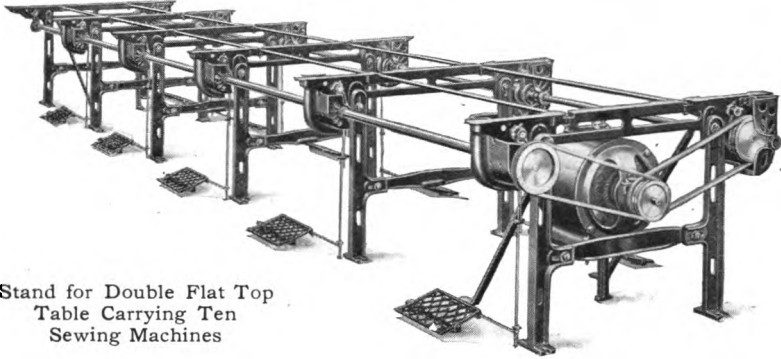

Stand for Double Flat Top
Table Carrying Ten
Sewing Machines

In this form of stand one Diehl electric motor is belted to two main lines of shafting running continuously and enclosed in a tubular cover, all completely covered by woodwork.

Each sewing machine has a **Singer Power Transmitter** on these main shafts and these transmitters are running only when the operator's foot applies pressure to the treadle on the floor; upon the release of this pressure the sewing machine is instantly stopped and it is thus absolutely controlled even to the limit of making but one stitch.

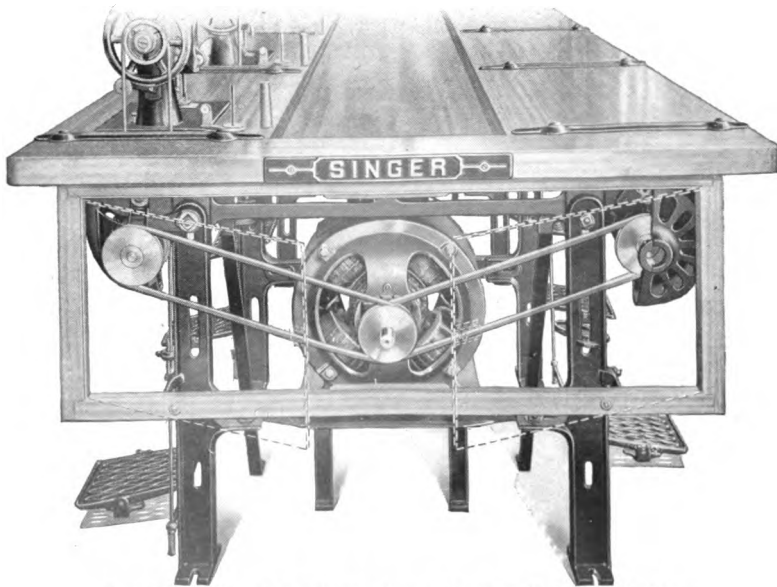

End View Showing Motor Connection to Driving Shafts—
Enclosure Doors Open

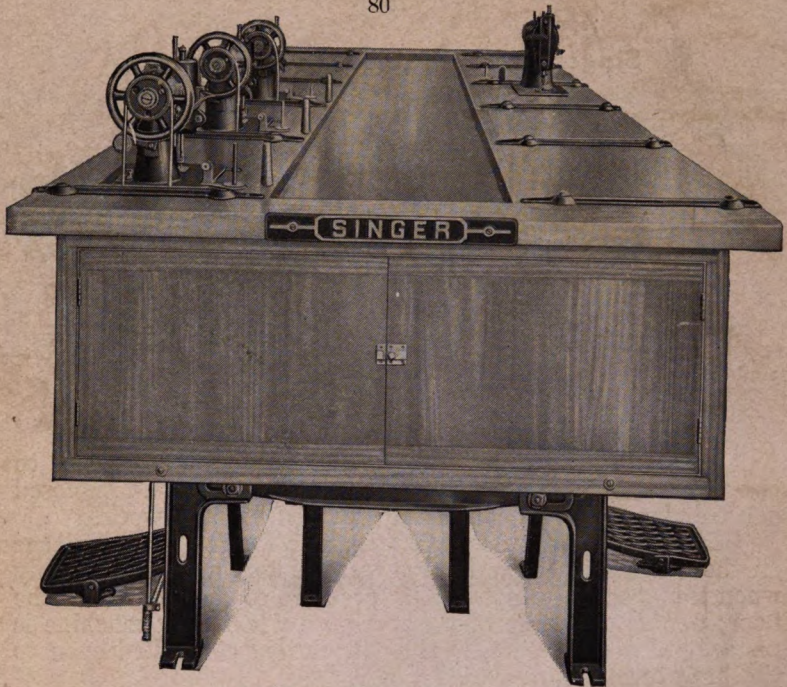

End View Showing Doors Closed

This **Belt Guard** is placed on the table so as to cover the running belt and the driven pulley on the sewing machine, thus preventing all contact by operators or by the material in process of manufacture.



Belt Guard

Singer Finger Guard: The use of this device makes it impossible for operators to have their fingers pierced by the needle; since it is not necessary for them closely to watch their fingers, more attention can be given to the work.

The guard is quickly attached to the presser bar of the machine and it can be readily adjusted to the desired height.

When not in use the finger guard is turned back and can again be placed in position by simply swinging it forward.

By the use of this appliance, together with the complete covering of all dangerous moving parts as previously shown, the risk of accident from Singer sewing machines in manufacturing industries is entirely overcome.



Finger Guard