

using the **SLIDE RULE** in **ELECTRONIC TECHNOLOGY**

by **CHARLES ALVAREZ**

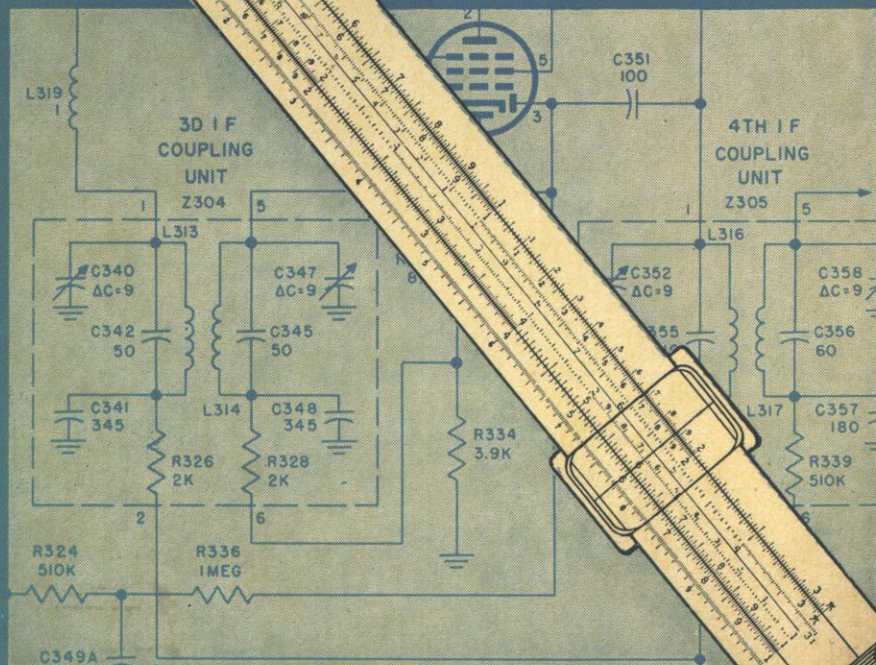

Using the Slide Rule in

**ELECTRONIC
TECHNOLOGY**

Copyright May 1962
JOHN F. RIDER PUBLISHER, INC.

All rights reserved. This book or any parts thereof may not be reproduced in any form or in any language without permission of the publisher.

Library of Congress Catalog Card Number 62-13398

Printed in the United States of America

FOURTH PRINTING, 1966

PREFACE

Electronic technology is basically the application of mathematics to the practical study of electrical and electronic phenomena. Starting with simple d-c circuits, continuing through a-c networks and into vacuum tube and transistor circuitry, the technician and engineer are continuously called upon to make mathematical calculations.

The slide rule expresses a means of rapid calculation, saving the technician and engineer hours of valuable, productive time. In addition, the slide rule represents a means of rapid double checking a solution to a mathematical electronic problem. While most technicians and engineers are familiar with the slide rule, many do not make proper and efficient use of this instrument. The presentation here shows how the slide rule can be put to its utmost utility. Three basic types of slide rules are used in this book: the *general purpose* slide rule, the *duplex* slide rule, and the *log-log* slide rule.

The general purpose rule, often called the *Manheim* rule, features the C and D scales and is the most popular rule in use today. Beyond these two scales, manufacturers differ as to the additional scales they provide. Most, however, supply the A, B, and CI scales.

There are other names for the duplex rules, such as the two-sided rule and the trig-function rule. It is a rule that contains all of the scales of the general purpose rule with the addition of the L, T, S, ST, CF, (DF or both), and K scales. Some manufacturers provide additional C and D scales on the reverse side. In electronic technology, the deci-trig type of duplex rule is mandatory. The deci-trig rule is one which gives angles in degrees and fractions of degrees, while the trig rule gives angles in degrees and minutes.

The log-log rules contain all of the scales of the duplex rule plus the

LL1, LL2, LL3, LL02, LL03, CIF scales. The greatest manufacturer variation occurs in the log-log rules. Some provide more than the three log-log scales, while others provide less. Some rules contain such additional scales as the DFM or the expanded square-root scales. Many manufacturers identify the log-log scales differently: LL00, ϵ scales, and natural log scales.

Each chapter is presented in a manner to enable self-study. The problems are simply defined, and examples and detailed solutions are shown. In general, these are followed by an exercise containing problems graduated in difficulty. Answers to the odd-numbered problems are supplied at the end of the book.

Each chapter discusses specific operations for all popular makes of rules. If the user has a rule which does not adapt to the discussions presented here, he should not discard the rule. Such instances will be rare; when they do occur, a little careful study will probably show the variations.

E. CHARLES ALVAREZ

Woodland Hills, California

CONTENTS

Chapter 1:	HOW TO READ THE SCALES	1
	Nomenclature • C and D Scales • Two-Digit Numbers • Three-Digit Numbers • <i>Exercise</i>	
Chapter 2:	OHM'S LAW AND THE C AND D SCALES	8
	Multiplication: Primary Digits — <i>Examples</i> — Secondary Digits — <i>Examples</i> — Tertiary Digits — <i>Examples</i> • Division • <i>Examples</i> • <i>Exercises</i>	
Chapter 3:	POWERS OF TEN	16
	Standard-Form Estimating • <i>Examples</i> • <i>Exercises</i>	
Chapter 4:	RULES OF EXPONENTS	19
	Multiplication • <i>Examples</i> • Division • <i>Examples</i> • <i>Exercises</i>	
Chapter 5:	PARALLEL RESISTANCE AND COMBINED OPERATIONS	23
	<i>Examples</i> • <i>Exercises</i>	
Chapter 6:	WATT'S LAW AND THE A AND B SCALES	27
	Power: Using Current Equation — <i>Examples</i> — Using Voltage Equation — <i>Examples</i> • <i>Exercises</i>	
Chapter 7:	TRANSFORMER TURNS RATIO AND THE C AND D SCALES	32
	Voltage and Current • <i>Examples</i> • <i>Exercises</i>	
Chapter 8:	INDUCTIVE REACTANCE AND CONTINUED PRODUCTS	35
	Inductive Reactances • <i>Examples</i> • Word Problems • <i>Exercises</i>	
Chapter 9:	IMPEDANCE AND THE B SCALE	39
	Inductance-Resistance Circuits • <i>Examples</i> • Capacitance- Resistance Circuits • <i>Exercises</i>	
Chapter 10:	PERIOD AND THE INVERTED SCALE	43
	Period • <i>Examples</i> • Other Reciprocal Functions • <i>Exercises</i>	

Chapter 11:	POWER GAIN AND THE L SCALE	47
	Logarithms • Examples • Negative Characteristic • Examples • Word Problems • Examples • Exercises	
Chapter 12:	PHASE ANGLE AND THE T SCALE	52
	Tangent Functions • Examples • Tangent Functions When T Scale Is On The Stock • Examples • Tangent Functions of Angles • Examples • Exercises	
Chapter 13:	IMPEDANCE AND THE S SCALE	58
	The S Scale • The Sine Function • Examples • Sine • Examples • Sine Function Applied to Circuit Problems • The Cosine Scale • Examples • Cosine Function • (Unmarked Rules) • Examples • Exercises	
Chapter 14:	POLAR-TO-RECTANGULAR TRANSFORMATION	66
	Notation • Rectangular Addition • Examples • Trans- formation to Rectangular Form • Examples • Polar-to- Rectangular Transformation (Special Rules) • Ex- amples • Exercises	
Chapter 15:	RECTANGULAR-TO-POLAR TRANSFORMATION	72
	Vector Division • Vector Addition • Transformations • Examples • Summing Up • Exercises	
Chapter 16:	THE NATURAL BASE e	78
	e Raised to a Positive Exponent • The LL3 Scale • Examples • The LL2 Scale • Examples • The LL1 Scale • Examples • e Raised to a Negative Exponent • The LL01, LL02, and LL03 Scales • Examples • The The LL0 and LL00 Scales • Examples • Exercises	
Chapter 17:	RC CIRCUITS	86
	Examples • Exercises	
Chapter 18:	INDUCTIVE REACTANCE AND THE FOLDED SCALES	90
	Folded Scales and Combined Operations • Examples • Inductive Reactance • Examples • Exercises	
Chapter 19:	RATIO AND MULTIPLICATION ON THE FOLDED SCALES	94
	Time Saving • Ratios • Examples • Exercises	
Chapter 20:	CAPACITIVE REACTANCE AND THE CIF SCALE	96
	Capacitive Reactance • Examples • Exercises	
APPENDIX A:	New Prefixes for Units	100
APPENDIX B:	Exponentials	101
ANSWERS TO PROBLEMS	104
INDEX	109

1

HOW TO READ THE SCALES

1-1. Nomenclature

FIGURE 1-1 shows a schematic diagram of the basic slide rule parts; the stock, the hairline, and the slide. In manuals supplied with the newly purchased slide rule, the stock is sometimes referred to as the *stator*. The hairline is often referred to as the *cursor* or the *indicator*. Throughout this book, all references to the various slide rule parts will be those listed in Fig. 1-1. The student should study these and memorize them since all of the examples refer to the parts of the rule by these names.

1-2. C and D Scales

Adjust the slide rule so that the left-hand index of the C scale and the left-hand index of the D scale (the numeral 1 in both cases) are exactly opposite each other. The C scale is found on the slide and the D scale on the stock. Follow along the C and D scales from left to right to the end of the rule, and note that the two scales are exactly alike. Any discussion of the D scale graduations (or readings) will automatically apply to the C scale.

The D scale contains one *large* set of numbers starting with one (1) at the left and extending to ten (10: shown as 1) at the right. Note that between the large numbers 1 and 2 there is a set of smaller numbers 1 through 9. The large numbers are "primary" graduations. These graduations indicate only the major divisions on the scale, and do not necessarily indicate an actual quantity 1, 2, 3, etc. The exact positions of the numbers on the D scale are indicated by a small vertical line from just above the

numeral to the edge of the rule. Figure 1-2 shows an example of the D scale and these primary divisions.

The distance between each two primary graduations is divided into 10 parts. This is shown by a group of vertical lines slightly shorter than

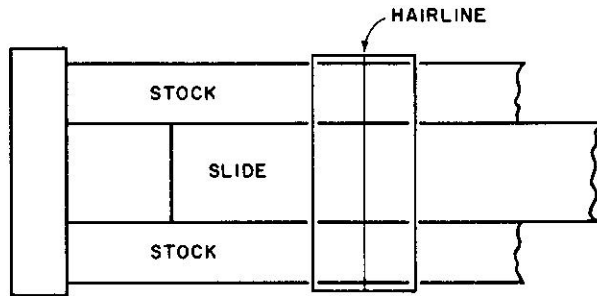

Fig. 1-1. Basic parts of a slide rule.

those used for the primary graduations. These "secondary" graduations are labeled with numbers only between the primary graduations of 1 and 2. Small rules (less than 10 in. long) may not have these secondary graduations numbered. Figure 1-3 indicates schematically the secondary graduations. The arrow shows 6 of the C scale set over 9.5 of the D scale. The graduations are indicated with numerals between primary graduations 1 and 2 only because space permits. The physical distance between primary graduations 9 and 10 is small, hence there is no space for numerals. The reason for this difference in space lies in the basic theory of the slide rules. The operations are fundamentally logarithmic.

1-3. Two-Digit Numbers

The student should study the following examples carefully in order to develop a *feel* for reading of the scales. Using the hairline, locate the

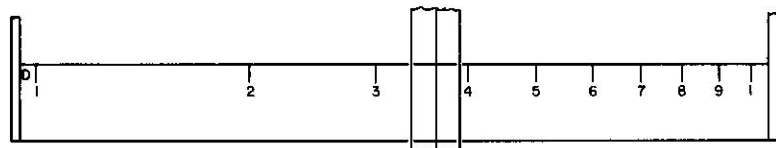

Fig. 1-2. Location of primary divisions on the D scale.

number 450 on the C scale. In this case, each of the primary graduations indicates hundreds. As an example, the left-hand index indicates 100; then moving to the right, each primary graduation indicates an additional hun-

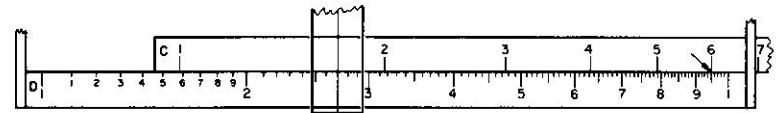

Fig. 1-3. Location of secondary divisions on D scale. Secondary divisions on C scale not shown.

dred. The right-hand index indicates 1000 and each of the secondary graduations indicate tens, so 450 is located between 4 and 5 at the fifth secondary graduation to the right of 4. See Fig. 1-4. Using the hairline, locate the number 0.087 on the C scale. In this case, each of the primary graduations indicates hundredths; that is, each represents 0.01; and

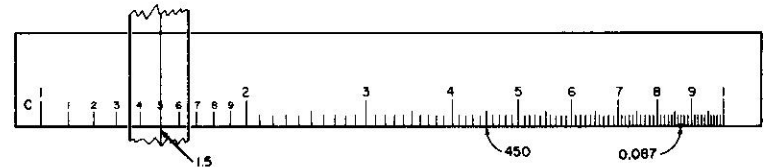

Fig. 1-4. Location of 450 and 0.087 on the C scale. Hairline is shown for a reading of 1.5

moving to the right, 0.02, 0.03, etc., to 0.1 at the right-hand index. To locate 0.087, move the hairline between the 8 and 9 primary graduations. The secondary graduations in this case represent thousandths markers; thus 0.087 is located. The assignment of what value the index takes is entirely arbitrary.

EXERCISE 1-3

The slide rule in Fig. 1-5 shows only the C scale. The lower-case letters

indicate reading points. Assume the left-hand index is represented by 1 and write in the indicated numbers:

- (a) _____ (d) _____
- (b) _____ (e) _____
- (c) _____ (f) _____

Assume the left-hand index is represented by 100:

- (g) _____ (j) _____
- (h) _____ (k) _____
- (i) _____ (l) _____

Assume the left-hand index is represented by 0.01:

- (a) _____ (h) _____
- (d) _____ (m) _____
- (f) _____ (n) _____

1-4. Three-Digit Numbers

There are tertiary graduations between secondary graduations on all makes of slide rules. The method of indicating them varies slightly with

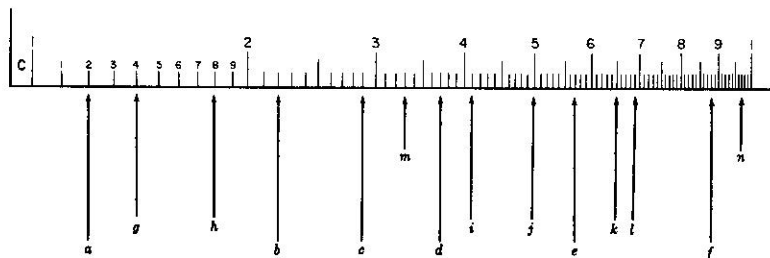

Fig. 1-5. Points on C scale, indicated by small letters, to be evaluated.

each make. Generally, the manufacturer of a slide rule will provide as many graduations as it is possible to inscribe within the scale. The student should not feel he has an inferior rule because it does not possess all the small graduations listed here. Remember, this is an all-inclusive list. All the possibilities of variation in rules have been considered here. If a manufacturer has omitted a particular set of graduations from his rule it has

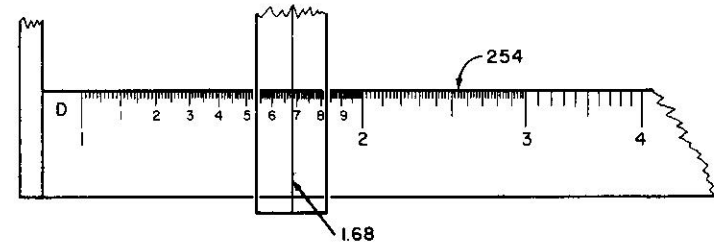

Fig. 1-6. Tertiary graduations which can be used for three-digit numbers.

probably been done as a result of compromise. Such factors as "ease of reading," "functionality," and "manufacturing costs" are some of the items usually considered. The tertiary graduations at the left end of the rule, such as between primary digits 1 and 2, have been divided into 10 parts. These graduations are indicated by the shortest markers of the group and are never numbered. Figure 1-6 shows a cutaway view of the portion of the slide rule containing tertiary graduations.

As an example of how these graduations are used, set the hairline over the number 1.68 on the C scale. In this case the left index represents 1 and each of the secondary graduations represents tenths. The number 1.68 is located eight tertiary digits to the right of 6 between the primary digits 1 and 2. The tertiary digits between 2 and 4 on most slide rules are divisions representing two one-hundredths (0.02) of the left index value. That is, there are five parts between each two secondary graduations. Figure 1-7 illustrates a slide rule and shows two examples of tertiary digits between the primary graduations of 2 and 4.

Assume the hairline is to be placed over the number 254. This number is located on the second small graduation mark to the right of the 5 secondary marker between the primary graduation of 2 and 3. See Fig. 1-6.

Assume the hairline is to be placed over the number 0.00328. This number is located between the 3 and 4 primary graduation markers. The left-hand C scale index in this case represents the number 0.001. Locate the secondary graduation 2 and then move the hairline four of the small

graduation marks to the right of the 2 marker. (Four small markers represent 0.00008, since each marker here represents 0.00002.) See Fig. 1-7.

If the number 2.73 is to be located on the slide rule, it is found that no graduation marker exists for this number. The number can be found in the following manner. Locate the numbers 2.72 and 2.74. The slide

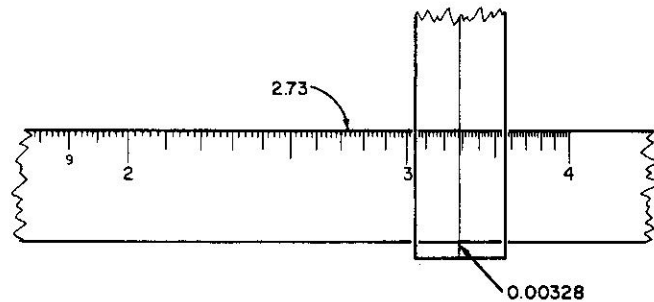

Fig. 1-7. How a three-digit number is read on a slide rule.

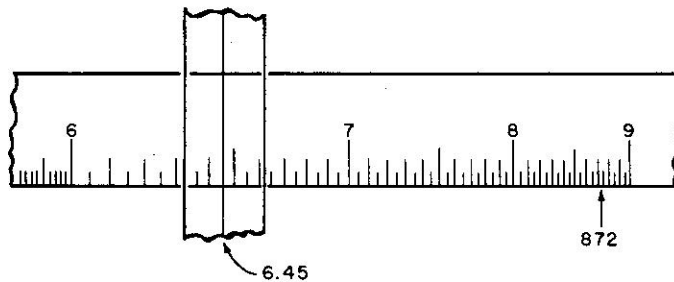

Fig. 1-8. Exact and estimated locations of three-digit numbers.

rule contains markers for each of these numbers. The distance halfway between these numbers is approximately correct. See Fig. 1-7.

The tertiary graduations between the primary graduations of 4 through 10 are generally all the same. In most cases, there is one marker between each two secondary graduations. This marker indicates 0.05 of the left index value. As an example, assume the hairline is to be placed at the 6.45 value. The hairline should be on 6 of primary graduations. Continue to move the hairline to the right past the secondary graduation marker rep-

resenting 4. The first marker to the right of 4 is about halfway and represents 6.45. See Fig. 1-8.

Assume the hairline is to be placed over the number 872. In this case, no marker exists for the number; therefore, an estimate is used. The

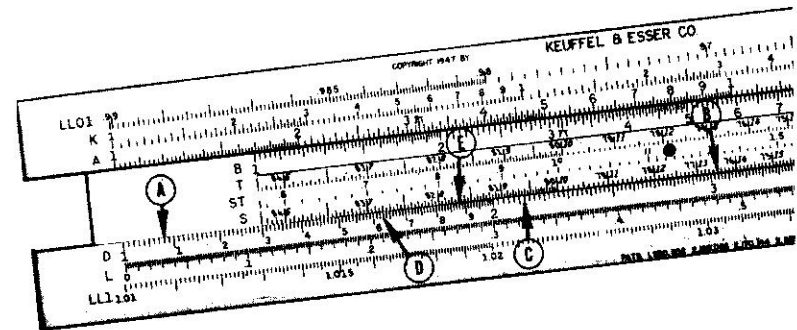

Fig. 1-9. Points on D scale, indicated by letters A-E, to be evaluated, assuming the left index represents 1.

hairline should be placed about two-fifths of the way between the markers for 870 and 875. See Fig. 1-8. This last example shows how estimating the position of the hairline is used at the right-hand side of the rule. Locate the number 1.986 on the C scale. Notice there are markers for the first three digits, 1, 9, and 8, but that there is no marker for the digit 6. The number is located about six-tenths to the right between the markers for 1.98 and 1.99.

EXERCISE 1-4

Refer to Fig. 1-9. Assume the left index represents 1 and identify the values indicated.

2

OHM'S LAW AND THE C AND D SCALES

2-1 Multiplication, Primary Digits

MULTIPLICATION on the slide rule usually involves the C and D scales. As has already been shown, the C and D scales are identical and number from 1 to 10, or 10 to 100, or 0.01 to 0.1, etc., from left to right. In order to multiply two numbers, set the index of the C scale over one of the numbers on the D scale. Locate the hairline over the other number on the C scale. (If the number is off the rule, use the other C scale index for your initial setting.) The answer is under the hairline on the D scale.

Example 1. 3×2

- Set the left-hand index of the C scale on 3 of the D scale [(A) in Fig. 2-1].
- Set the hairline over 2 on the C scale [(B) in Fig. 2-1].
- Read the answer under the hairline on the D scale [(C) in Fig. 2-1].

$$3 \times 2 = 6$$

Example 2. 3×5

- Set the right-hand index of the C scale over 5 on the D scale.
- Set the hairline over 3 on the C scale.
- Read the answer under the hairline on the D scale.

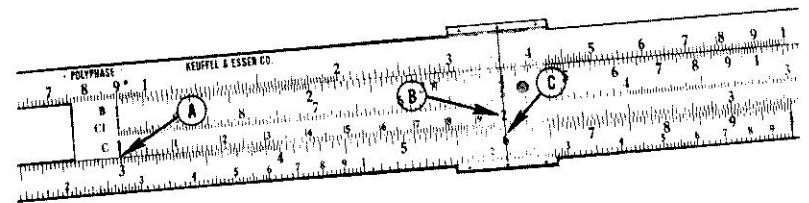

Fig. 2-1. Multiplication setting on slide rule for 3 times 2.

Since the number 5 under the hairline is between primary graduations 1 and 2, the number is 15.

$$3 \times 5 = 15$$

Example 3. 50×4

- Set the right-hand C scale index over 5 on the D scale.
- Set the hairline over 4 on the C scale.
- The number on the D scale under the hairline is 2; however, by estimating the answer from the original problem, the answer is found to be 200.

EXERCISE 2-1

- | | | |
|-------------------|-------------------|---------------------|
| (1). 2×4 | (5). 8×5 | (9). 20×2 |
| (2). 5×4 | (6). 6×5 | (10). 7×4 |
| (3). 5×2 | (7). 2×8 | (11). 10×4 |
| (4). 3×4 | (8). 9×2 | (12). 6×8 |

2-2. Multiplication, Secondary Digits

Example 1. 1.8×4.5

Before multiplying the numbers, look at the problem and estimate *about* what the answer should be. This estimate will help you decide where the decimal point is placed. Example 1 indicates the answer should be about 2×4 , or near 8. After estimating, perform the operations.

- Set the left-hand index of the C scale on 1.8 of the D scale [(A) of Fig. 2-2].
- Set the hairline over 4.5 on the C scale [(B) in Fig. 2-2].

- (c). Read the answer under the hairline on the D scale [(C) of Fig. 2-2].

$$1.8 \times 4.5 = 8.1$$

Example 2. 9.4×5

Estimate the answer to be about 10×5 or near 50.

- (a). Set the right-hand index of the C scale over 9.4 on the D scale.

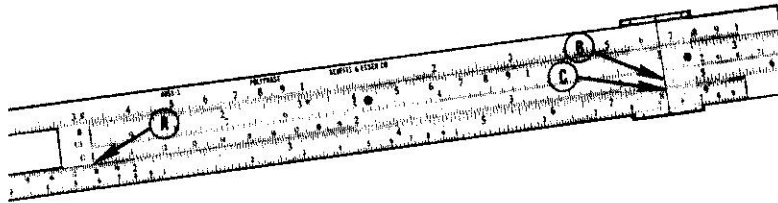

Fig. 2-2. Multiplication setting for two-digit numbers on slide rule.

- (b). Set the hairline over 5 on the C scale.
- (c). Read the answer on the D scale under the hairline.

$$9.4 \times 5 = 47$$

Example 3. 1.6×7.5

Estimate the answer to be about 2×7 or near 14.

- (a). Set the right-hand index of the C scale over 1.6 on the D scale.
- (b). Set the hairline over 7.5 on the C scale.
- (c). Read the answer under the hairline on the D scale.

$$1.6 \times 7.5 = 12$$

EXERCISE 2-2

- | | | |
|-----------------------|-----------------------|------------------------|
| (1). 1.9×2 | (5). 1.5×2.4 | (9). 5×1.1 |
| (2). 9.5×8.0 | (6). 1.6×2.5 | (10). 1.1×2.0 |
| (3). 6.5×6 | (7). 7.5×1.2 | (11). 9.6×2.5 |
| (4). 3.5×4 | (8). 1.4×6.5 | (12). 1.9×4.0 |

2-3. Multiplication, Tertiary Digits

Example 1. 1.55×3

An estimate of the answer is about 2×3 , or a value slightly less than 6.

- (a). Set the left-hand C scale index over 1.55 on the D scale [(F) in Fig. 2-3].
- (b). Set the hairline over 3 on the C scale [(G) of Fig. 2-3].
- (c). Read the answer under the hairline on the D scale. [(H) of Fig. 2-3].

$$1.55 \times 3 = 4.65$$

Example 2. 6.45×3.6

Estimate the answer to be about 6×4 or near 24.

- (a). Set the right-hand C scale index over 6.45 on the D scale.

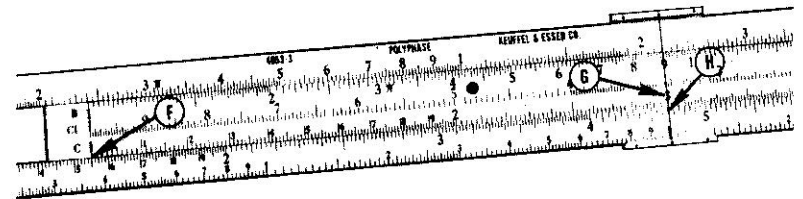

Fig. 2-3. Multiplication setting on slide rule for tertiary numbers.

- (b). Set the hairline over 3.6 on the C scale.
 - (c). Read the answer on the D scale under the hairline.
- Note that the answer under the hairline is 23.2. The actual answer is 23.22. With further practice this kind of accuracy will be possible.

Example 3. 1.96×2.8

- (a). Set the left-hand C scale index over 1.96 on the D scale.
- (b). Set the hairline over 2.8 on the C scale.
- (c). Read the answer on the D scale under the hairline.

$$1.96 \times 2.8 = 5.49$$

EXERCISE 2-3

- | | | |
|-------------------------|--------------------------|---------------------------|
| (1). 1.4×7.5 | (6). 3×1.01 | (11). 8.3×4.6 |
| (2). 8.45×5.55 | (7). 9.15×9.85 | (12). 1.06×9.7 |
| (3). 1.115×3.1 | (8). 1.111×1.15 | (13). 2.05×7.95 |
| (4). -1.5×8.4 | (9). 2.88×3.14 | (14). 1.59×-1.54 |
| (5). -1.77×-7 | (10). 7.1×9.95 | (15). 3.34×2.28 |

(16). In the circuit of Fig. 2-4, if the current in the circuit is 2 amp, what is the voltage drop across each resistor?

(17). If the current is decreased to 1.6 amp, what will be the voltage drops across the resistors?

(18). If the current is decreased to 1.3 amp and the resistance of each

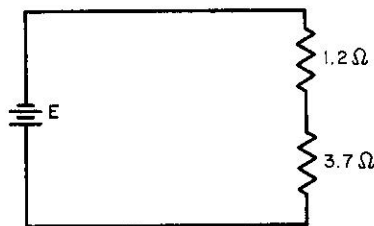

Fig. 2-4. Simple d-c circuit.

resistor is reduced to half its present value, what will be the voltage drop across each resistor?

(19). If the current flowing in a series circuit is 1.55 amp and there are five 8.75-ohm resistors in the circuit, what will the voltage drop across each resistor be?

(20). A series circuit contains three resistors and 5.85 amp of current is flowing. The first resistor is 7.5 ohms, and the second resistor is three times as large as the first, while the third resistor is twice as large as the second. Calculate the voltage drop across each resistor.

2-4. Division

Division on the slide rule is the inverse operation of multiplication. Once again, the C and D scales are used.

Before examples are shown, however, one rule should be committed to memory: "The *answer* and the *dividend* are *always* on the same scale."

Examine the division of 12 by 6. Study the names of the parts of the division problem.

$$\frac{\text{(dividend)}}{\text{(divisor)}} \frac{12}{6} = 2 \text{ (quotient)}$$

If this problem were done on the slide rule, the answer 2 would have been on the same scale as the dividend 12. It is useful to mention this here because other methods of dividing will be studied later. Many slide rule operators have developed a special "pet" way of dividing. However,

regardless of the method you use, remember the answer is *always* on the same scale with the dividend.

Example 1. 8/4

- (a). Set the hairline over 8 (the dividend) on the D scale [(A) of Fig. 2-5].
- (b). Set 4 of the C scale under the hairline [(B) of Fig. 2-5]. (The

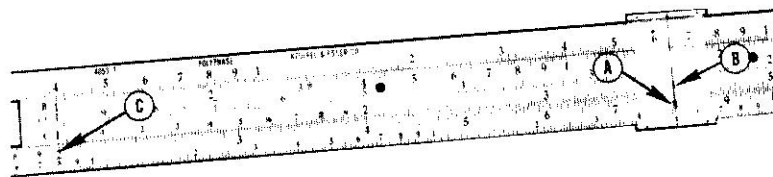

Fig. 2-5. Division setting, on slide rule, for 8 divided by 4.

- answer *must* be on the D scale because the dividend is on the D scale).
- (c). Read the answer on the D scale under the C scale index [(C) of Fig. 2-5].

$$8/4 = 2$$

Example 2. If 12 v is developed across a 2.4-ohm resistor, what current is flowing through the resistor?

$$I = E/R \quad I = 12/2.4$$

- (a). Set the hairline over 12 on the D scale.
- (b). Set 2.4 of the C scale under the hairline.
- (c). Read the answer on the D scale (5 amp) under the C scale index.

Example 3. If a current of 4.8 amp is flowing through a resistor, and the voltage drop across the resistor is 36 v, how large is the resistor?

$$R = E/I \quad R = 36/4.8$$

- (a). Set the hairline over 36 on the D scale.
 - (b). Set 4.8 of the C scale under the hairline.
 - (c). Read the answer on the D scale, 7.5 ohms, under the C scale index.
- Because the C and D scales are identical, division can be performed in a way opposite to the one just described. If in the third example each reference to the C scale were performed on the D scale and each reference

to the D were performed on the C scale, the answer would be the same. Repeat the problem in Example 3 as follows.

$$R = E/I \quad R = 36/4.8$$

- Set the hairline over 4.8 on the D scale. (Remember that 4.8 is the divisor.)
- Set 36 of the C scale under the hairline.

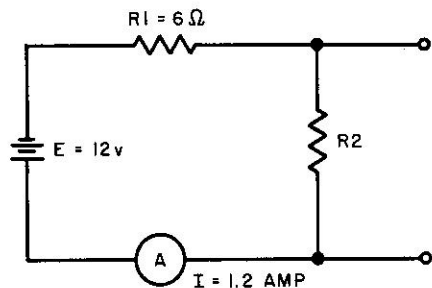

Fig. 2-6. Simple d-c circuit problem. Find R_2

- Since the answer must be on the same scale as the dividend, read the answer on the C scale, 7.5 ohms, above the D scale index.

EXERCISE 2-4

Perform the following simple divisions.

- | | |
|--------------------|---------------------|
| (1). $42 \div 14$ | (6). $8.1 \div 3$ |
| (2). $8.5 \div 3$ | (7). $9.1 \div 1.3$ |
| (3). $18 \div 4$ | (8). $11.5 \div 25$ |
| (4). $1 \div 2.5$ | (9). $54 \div 19$ |
| (5). $55 \div 2.5$ | (10). $9 \div 31$ |

EXERCISE 2-5

- If 12.6 v is developed across a resistor of 30 ohms, what is the current through the resistor?
- A current of 2.6 amp flows through two resistors connected in series. The voltage across R_1 is 34.6 v and the voltage across R_2 is 16.4 v. Which of the two resistors is larger? Prove your answer.
- If 1.85 amp is flowing through two series resistors of 12 ohms and 52 ohms, what is the voltage drop across each resistor?
- In the circuit of Fig. 2-6 the resistance of R_2 is what?

- If a soldering iron draws 1.2 amp of current from a 110-v source, what is the resistance of the heating element?
- What is the total resistance in the circuit of Fig. 2-7, when the current through the diode is 0.2 amp?
- If a 20-, 30-, and 40-ohm resistor are connected in series, and the

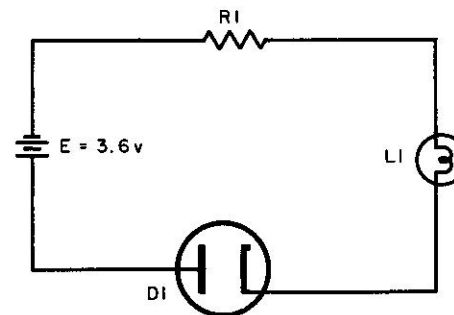

Fig. 2-7. D-c circuit problem. The current through the diode is known.

voltage drop across the 20-ohm resistor is 25 v, what is the voltage drop across each of the other two resistors?

- A resistor is rated at 330 ohms by the color code. When a 110 v is impressed across it, a current of 0.4 amp flows. According to the meter readings, what is the percentage of error in the color markings?
- In Problem 8, what would the current be if there were no error in the color markings?
- A meter dial reads 0.5 amp when connected to a 37-v d-c source. What is the d-c resistance of the meter movement?
- In Problem 6, assume $R_1 = 10$ ohms and the resistance of $L_1 = 60$ ohms, what current flows through the diode, if the total resistance is 150 ohms?
- If, in Problem 11, the applied voltage is increased to 10 v and as a result the diode resistance has decreased 4 ohms, what new current will flow in the circuit?

POWERS OF TEN

MULTIPLYING and dividing with numbers between 1 and 100 in electronics is generally the exception rather than the rule. Few, if any, problems are as simple as that. Most of the problems involve large numbers up in the millions and small numbers in the millionths. It is difficult to manipulate extremely large or small numbers without making errors in decimal places. Although many *memory* tricks have been devised to aid in placing the decimal point there remains only one safe method; powers of ten. There are several ways of expressing a number. Study the list below and note the number of ways 2000 can be written.

- (1). $2000 = 2000 \times 1$ (3). $2000 = 200 \times 10$
 (2). $2000 = 2 \times 1000$ (4). $2000 = 20 \times 100$
 (5). $2000 = 0.2 \times 10,000$

The following power-of-ten list indicates equivalencies.

$$\begin{array}{ll} 10 = 10^1 & 1000 = 10^3 \\ 100 = 10^2 & 10000 = 10^4 \end{array}$$

If the numbers equaling 2000 were replaced by the equivalents with powers of ten, the five examples could be written

- (1). $2000 = 2000 \times 10^0$ (3). $2000 = 200 \times 10^1$
 (2). $2000 = 2 \times 10^3$ (4). $2000 = 20 \times 10^2$
 (5). $2000 = 0.2 \times 10^4$

Any number can be expressed by a number including powers of ten, by converting the number to *standard form*. As an example, the number

362 can be written as 3.62×10^2 , or 0.000477 can be written as 4.77×10^{-4} . A number is said to be in the *standard form* when there is one significant figure to the left of the decimal point. Any number can be changed to standard form with the aid of powers of ten.

A number which is not in standard form is expressed in standard form by (1). moving the decimal point from its original position to a position where one significant figure is to the left of the decimal point; and (2). counting the number of decimal places the point is moved and assigning that number as the power of the multiplying factor of ten.

Example 1.

The number 134000 can be written as 1.34×10^5 . (Write 1.34000.; the decimal point has been moved five places, hence the power of ten is 5.)

Example 2.

The number 0.0000603 can be written as 6.03×10^{-5} .

Example 3.

The number 84.3 can be written as 8.43×10 .

EXERCISE 3-0

Convert the following numbers to the standard form.

- (1). 162000 (4). 99.3 (7). 893000
 (2). 0.00053 (5). 0.00804 (8). 0.04
 (3). 836000 (6). 6.049000 (9). 62.04

3-1. Standard-Form Estimating

As was stated earlier, the greatest number of errors in the use of the slide rule occur not in the manipulations but in where the decimal point is placed. For this reason, learning to *estimate* an approximate answer is extremely important. There are many ways of learning to estimate answers with the slide rule. The new student should rely only on the most accurate of these, namely, powers of ten. Without pencil, paper, or slide rule, give a quick estimate of the following problem.

$$\frac{(29100) (401000)}{(0.0019)}$$

The second example is so simple that it hardly need to be mentioned. Actually, the first problem is just as simple as the second. If the decimal points in the first example were repositioned the problem could be written

$$\frac{(2.91) (4.01)}{(1.9)}$$

Now the rough estimate is easy. The answer can be estimated by multiplying 3 (actually 2.91) by 4 (4.01) and dividing by about 2 (1.9). The answer is very near 6. Since the numbers in the last example are in their standard form it is very easy to estimate the correct answer. The actual significant figures of the answer are found on the slide rule, while the powers of ten will determine where the decimal is placed.

Study the following examples of estimating the approximate value of the answer.

Example 1.
$$\frac{0.000452}{(0.064) (5.33)}$$

Change all the numbers to standard form and temporarily disregard the powers of ten to be added to the number.

$$\frac{(4.52)}{(6.4) (5.33)}$$

An approximate guess of this operation is 4 divided by about 30, hence the answer is about 1/7, or about 0.14. The important consideration here is that we know where the decimal is to be placed.

Example 2.
$$\frac{(1550000) (3900)}{(21000)}$$

Change all the numbers to standard form and temporarily disregard the powers of ten.

$$\frac{(1.55) (3.9)}{(2.1)}$$

The answer here is roughly 3. . . . Even if the actual answer turns out to be 2-point-something it is of no importance to us. Again, the important factor is that we know where the decimal point is to be placed.

EXERCISE 3-1

In the following problems, convert the numbers to standard form and estimate the position of the decimal point.

$$\begin{array}{ll} (1). \frac{(39) (51)}{2.8} & (3). \frac{2800}{(386) (7200)} \\ (2). \frac{(0.0000485) (0.0097)}{(0.0000321)} & (4). \frac{1}{(0.000379) (0.0993)} \end{array}$$

4

RULES OF EXPONENTS

THE formal rules and index laws of exponents can be found in any reliable mathematics textbook. The examples shown here are only those required for understanding the fundamental operations using powers of ten.

4-1. Multiplication

If 1000 were multiplied by 100 the answer would be 100,000. Stated as an equation,

$$(1000) (100) = 100,000$$

By changing these quantities to powers of ten, the equation becomes.

$$(10^3) (10^2) = 10^5$$

Notice that the sum of the exponents in the original product is equal to the exponent in the answer. The formal rule can be stated: When multiplying like literal numbers, assign the sum of the exponents to the common literal number.

$$a^m \cdot a^n = a^{m+n}$$

Example 1. 34000×30000

Convert both numbers to standard form.

$$3.4 \times 10^4 \times 3 \times 10^4$$

Multiply the like literal numbers (10 in this case) by adding the exponents.

$$3.4 \times 3 \times 10^8$$

Using the slide rule, multiply the significant numbers.

$$3.4 \times 3 \times 10^8 = 10.2 \times 10^8$$

If the student finds it necessary to express the number in its original form the decimal point is moved the number of places indicated by the power of ten.

$$1020000000.0$$

Example 2. $0.00000465 \times 0.0000495$

Convert both numbers to standard form.

$$4.65 \times 10^{-6} \times 4.95 \times 10^{-5}$$

With the slide rule, multiply the significant numbers, and by the rules of exponents add together the exponents of 10.

$$4.65 \times 4.95 \times 10^{-11} = 23.02 \times 10^{-11}$$

The answer can be written in standard form to aid in further operations.

$$2.302 \times 10^{-10}$$

EXERCISE 4-1

Convert the following products to standard form and multiply.

- | | |
|--|-----------------------------------|
| (1). (83000) (7300) | (6). (183) (10^2) (8.6) |
| (2). (65.30) (0.0064) | (7). (0.035) (10^{-3}) (9.91) |
| (3). (0.000891) (0.064) | (8). (0.991) (0.844) |
| (4). (6.04) (3.71) | (9). (1006) (16600) |
| (5). (0.9301) (1.2×10^{-3}) | (10). (83.05) (1.92) |

4-2. Division

If 1000 were divided by 100 the answer would be 10. Stated as an equation,

$$\frac{1000}{100} = 10$$

By changing these quantities to powers of ten, the equation becomes

$$10^3/10^2 = 10^1$$

Notice that the difference of the exponents of the dividend and the divisor is equal to the exponent of the answer. The formal rule from index laws of exponents is stated

$$a^m/a^n = a^{m-n}$$

Example 1. $340000/3000$

Convert both numbers to standard form.

$$(3.4 \times 10^5)/(3 \times 10^3)$$

Using the slide rule, divide the significant numbers and by the rules of exponents subtract the exponents of ten.

$$(3.4/3) \times 10^2 = 1.13 \times 10^2, \text{ or } 113$$

Example 2. $0.0000458/0.00555$

Convert both numbers to standard form.

$$(4.58 \times 10^{-5})/(5.55 \times 10^{-3})$$

Divide on the slide rule and apply the rules of exponents for division.

$$(4.58/5.55) \times 10^{-2} = 0.825 \times 10^{-2} \text{ or } 0.00825$$

Example 3. $4370000/3350000$

Convert both numbers to standard form.

$$(4.37 \times 10^6)/(3.35 \times 10^6)$$

Applying the rules of exponents, the problem is written

$$(4.37/3.35) \times 10^0$$

Since any quantity raised to the zero power is equal to 1, the problem becomes

$$(4.37/3.35) \times 1$$

Dividing on the slide rule,

$$4.37/3.35 = 1.305$$

EXERCISE 4-2

Convert the following problems to standard form and divide.

- | | |
|-------------|-------------------|
| (1). 105/75 | (2). 135000/85800 |
|-------------|-------------------|

- | | |
|--------------------|---------------------------------------|
| (3). 0.0053/0.0783 | (7). 1.00/0.0100 |
| (4). 1/56300 | (8). $(45.6 \times 10^9)/175$ |
| (5). 0.874/0.973 | (9). $(0.074 \times 10^{-4})/10^{-8}$ |
| (6). 0.0682/21 | (10). 0.444/0.066 |

5

PARALLEL RESISTANCE AND
COMBINED OPERATIONS

IF two resistors R_1 and R_2 are connected in parallel, the total equivalent resistance is equal to the reciprocal of the sum of the reciprocals of the two resistors. This equation can be reduced to be the product of the two resistances divided by their sum.

$$R_t = \frac{1}{\frac{1}{R_1} + \frac{1}{R_2}} \text{ or } R_t = \frac{(R_1)(R_2)}{R_1 + R_2}$$

This total resistance, by the product over the sum method, can be found on the slide rule by one combined operation using the C and D scales.

The process of estimating the answer is greatly simplified in these problems, because when two resistors are connected in parallel the total equivalent resistance is *always* less than the smaller resistor.

Example 1.

If a 20-ohm resistor is connected in parallel with a 30-ohm resistor, what is the equivalent resistance?

$$R_t = (20)(30)/(20 + 30) = (20)(30)/50$$

- Estimate the answer to be about 15.
- Set 50 of the C scale above 20 on the D scale [(A) in Fig. 5-1].
- Set the hairline over 30 on the C scale [(B) in Fig. 5-1].
- Read the answer under the hairline on the D scale; 12 ohms [(B) of Fig. 5-1].

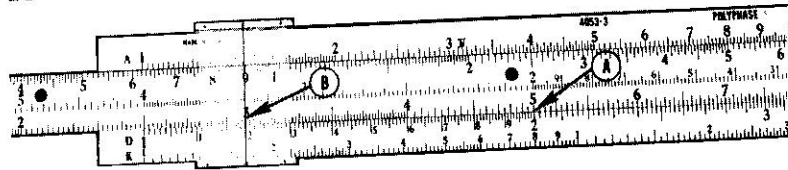

Fig. 5-1. Slide rule setting for solving a parallel resistance problem.

Example 2.

Two resistors, 800 K and 2.5 meg, are connected in parallel. What is the equivalent resistance?

- (a). Before setting up this problem on the slide rule it is necessary to have both resistor values in the same units. In this case it is

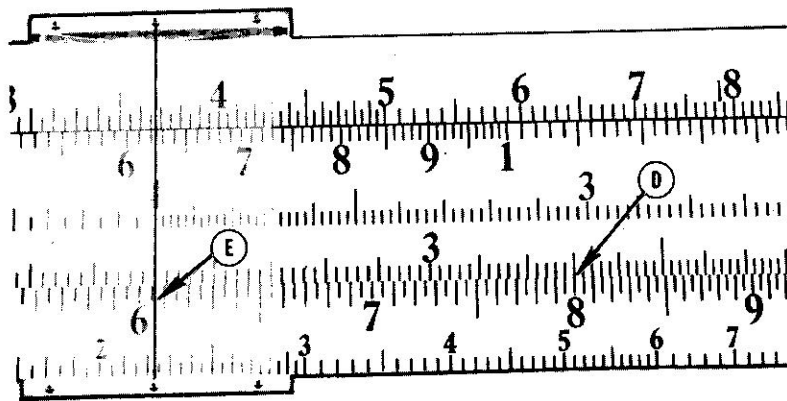

Fig. 5-2. Setting on slide rule for solving equivalent resistance of two resistors in parallel.

simpler to express 800 K as 0.8 meg. If both resistors are expressed in megohms, the answer found on the D scale will also be in megohms.

- (b). Locate 0.8 on the D scale and set 3.3 (0.8 + 2.5) of the C scale above it [(D) in Fig. 5-2].
 (c). Set the hairline over 2.5 on the C scale and read the answer on the D scale under the hairline; 0.606 meg. [(E) in Fig. 5-2].

EXERCISE 5-1

- (1). Two resistors, 7 ohms and 2 ohms, are connected in parallel. Find the total resistance.
- (2). What equivalent resistance will result from 83 ohms paralleled by 24 ohms?
- (3). What is the total resistance of 5.3 meg paralleled by 840 K?

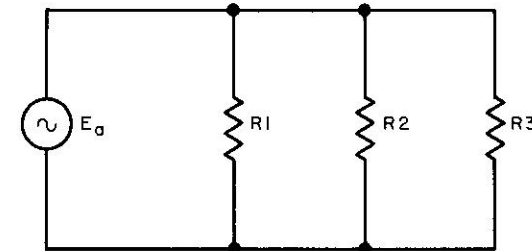

Fig. 5-3. Three resistors in parallel.

- (4). If two 15-ohm resistors connected in series are paralleled by another 15-ohm resistor, what is the equivalent resistance?
- (5). If 120 ohms is paralleled by 7.9 K what is the total equivalent resistance?
- (6). In the circuit of Fig. 5-3, if $R1 = 22$ ohms, $R2 = 40$ ohms, and $R3 = 24$ ohms, what is the total equivalent resistance?
- (7). In Problem 6, if the value of resistor $R2$ were doubled, how much would the total equivalent resistance increase or decrease?
- (8). If a 10-ohm resistor were added in series with $R1$ in Problem

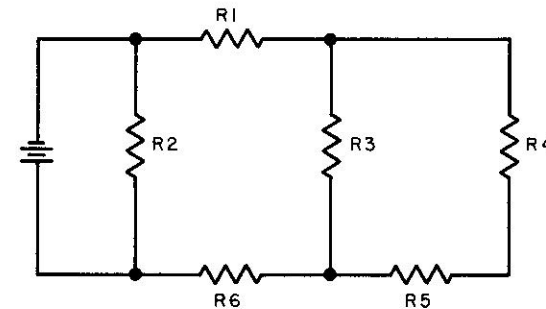

Fig. 5-4. Series-parallel circuit problem.

6 and all other factors remained the same, what would be the total resistance?

(9). In the circuit of Fig. 5-4, if $R_1 = 10$ ohms, $R_2 = 20$ ohms, $R_3 = 30$ ohms, $R_4 = 40$ ohms, $R_5 = 50$ ohms, and $R_6 = 60$ ohms, what is the equivalent total resistance?

(10). In Problem 9, if the value of R_4 were doubled and the value of R_5 were halved, what change in the total resistance would occur?

In many cases it will be necessary to reverse indices. This process can be avoided by using the A and B scales instead of the C and D scales. All of the preceding problems and examples should be repeated, substituting the A scale for the D scale and the B scale for the C scale. Problem 2 can be worked by setting 107 of the B scale under 83 of the A scale, and setting the hairline over 24 on the B scale and reading the answer on the A scale (18.6 ohms).

6

WATT'S LAW AND THE A AND B SCALES

6-1. Power: Using Current Equation

THE equation for power is

$$P = I^2R$$

Example 1.

If a current of 2 amp flows through a 4-ohm resistor, 16 watts of power will be dissipated.

$$P = (2)^2(4) = 16 \text{ w}$$

The mechanics of solving for power on the slide rule involves the use of the C, D, A, and B scales. Examine closely the A and B scales. They are identical scales; the A on the stock and the B on the slide. The A and B scales consist of two contracted C scales set side by side. The A scale in conjunction with the D scale is used for finding square roots and squares. The addition of the B scale enables combined operations. In the previous example we found the power to be 16 w. Set up the problem on the slide rule.

- (a). Set the left-hand C scale index over 2 on the D scale [(A) in Fig. 6-1].
- (b). Set the hairline over 4 on the B scale [(B) in Fig. 6-1].
- (c). Read the answer on the A scale under the hairline [(C) in Fig. 6-1].

As an experiment, set the right-hand C scale index over 2 on the D scale. Set the hairline over 4 on the B scale. Read the power, 16 w, on the A scale. It is difficult to make an error in the *mechanics* of these prob-

lems; the greatest possibility of error generally occurs in placing the decimal point.

Example 2.

What power is dissipated in a 350-ohm resistor when 0.75 amp flows through it?

$$P = (0.75)^2(350)$$

A useful aid in estimating the answer is in moving the decimal points.

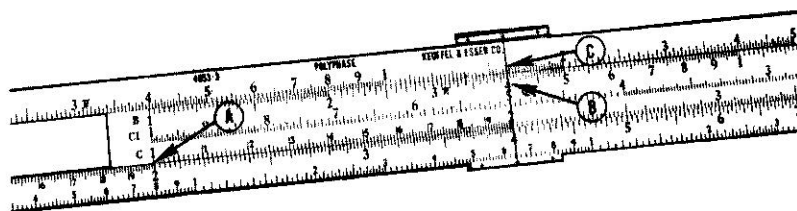

Fig. 6-1. Solution of a power problem on the slide rule, using the A, B, C, and D scales.

Moving the decimal point in 0.75 one place to the right cancels two decimals to the left in 350.

$$P = (7.5)^2(3.50)$$

Now estimating is simplified, 7² times 3 or about 150.

- (a). Set the right-hand C scale index over 7.5 on the D scale.
- (b). Set the hairline over 3.5 on the B scale.
- (c). Read the answer, 197 w, on the A scale.

Example 3. A current of 15 ma through a 400-K resistor will dissipate

$$P = (0.015)^2(40)(10^4)$$

Estimate the answer $(1.5)^2 \times (40)$ or about 80.

- (a). Set the C scale index over 1.5 on the D scale.
- (b). Set the hairline over 40 on the B scale.
- (c). Read the answer, 90 w, on the A scale.

EXERCISE 6-1

- (1). A current of 3 amp through an 8-ohm resistor will dissipate how many watts?
- (2). How much power is produced across a 185-ohm resistor when 2 ma flows through it?

- (3). 9 ma of current through 845-ohms will produce how many watts?
- (4). In the circuit of Fig. 6-2, how much power is dissipated at each resistor?

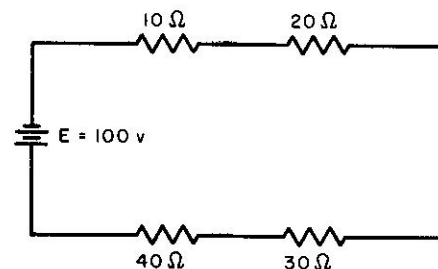

Fig. 6-2. Schematic for Problem 4, Exercise 6-1.

- (5). In the circuit of Fig. 6-3, how much power is dissipated?
- (6). How much power is dissipated at each resistor in Problem 5?
- (7). If a resistor whose value is unknown develops 7.3 mw when 0.2 ma flows through it, how much power would be developed if the current doubled?

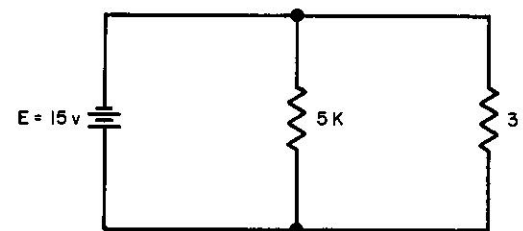

Fig. 6-3. Schematic for Problem 5, Exercise 6-1.

- (8). If 4.2 ma flows through 50 K, what power is dissipated? (*Hint:* If the problem is figured with current in milliamperes and the resistance in megohms, the answer will be in watts.)

6-2. Power: Using Voltage Equation

The use of the A and B scales in conjunction with the C and D scales provides a number of time-saving operations. Practice in using these

scales should continue until the operator feels secure working any type of square-root problem.

The following is given as additional practice.

The voltage equation for power is

$$P = E^2/R$$

Example 1. What power in watts is developed at a 25-ohm resistor when 4 v is developed across it?

$$P = E^2/R$$

$$P = 4^2/25$$

- (a). Set the hairline over 4 on the D scale [(D) in Fig. 6-4].

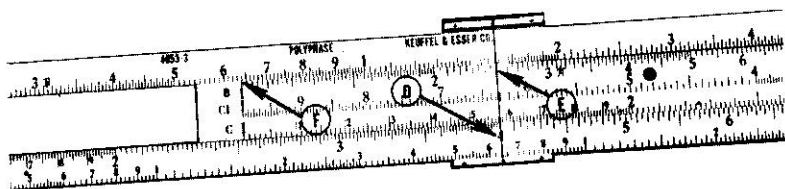

Fig. 6-4. Slide rule setting for power dissipation, when voltage and resistance are known.

- (b). Set 25 of the B scale under the hairline [(E) in Fig. 6-4].
 (c). Read the power on the A scale above the B scale index [(F) in Fig. 6-4]. The 25 of either of the B scales may be used and the answer will appear on the A scale above the B scale index.

$$P = 0.64 \text{ w}$$

Example 2. A 68-K resistor has 3.72 mv developed across it. What power will be developed at the resistor?

$$P = (3.72 \times 10^{-3})^2 / (6.8 \times 10^4)$$

Perform operations with exponents and change all numbers to standard form.

$$P = (3.72)^2(10^{-3})^2 / (6.8 \times 10^4) = [(3.72)^2/6.8] \times 10^{-10}$$

- (a). Set the hairline over 3.72 on the D scale.
 (b). Slide 6.8 of the B scale under the hairline.
 (c). Read the power on the A scale above the B scale index.

$$P = 2.04 \times 10^{-10}$$

EXERCISE 6-2

- (1). If a 50-ohm resistor develops 7.8 v across it, what power is developed at the resistor?
- (2). If the voltage in Problem 1 were doubled, what increase in power would be recorded?
- (3). Three series resistors of 15 K, 20 K, and 45 K have 100 v applied to the circuit. What power is dissipated by the total circuit?
- (4). If two coils are connected so that the coefficient of coupling is equal to 1, the inductance of the secondary is given as $L_s = M^2/L_p$, where M is equal to the mutual inductance and L_p is equal to the inductance of the primary. If M is equal to 0.36 and L_p is 16.8 mh, what is the value of L_s ?
- (5). If a 3-K and a 5-K resistor are connected in parallel and a voltage of 6.5 v is applied to the circuit, what is the difference in power developed across each of the resistors?

7

TRANSFORMER TURNS RATIO AND THE C AND D SCALES

7-1. Voltage and Current

THE transformer turns ratio equation for voltages is given as

$$N_p/N_s = E_p/E_s$$

where

N_p = number of turns in the primary, N_s = number of turns in the secondary, E_p = voltage across the primary, and E_s = voltage across the secondary.

Example 1.

A transformer has 50 turns in its primary and 250 turns in its secondary. What is the secondary voltage when 3 v is applied to the primary?

$$50/250 = 3v/E_s$$

- (a). Set 50 of the C scale over 250 on the D scale [(A) in Fig. 7-1].
- (b). Set the hairline over 3 on the C scale [(B) of Fig. 7-1].
- (c). Read the answer on the D scale [(C) of Fig. 7-1].

$$E_s = 15 \text{ v}$$

Example 2.

The turns ratio of a transformer is 2 to 7. If 8.4 v is measured across the secondary, the primary voltage is

$$2/7 = E_p/8.4$$

- (a). Set the 2 of the C scale over 7 of the D scale.
- (b). Set the hairline on 8.4 of the D scale.
- (c). Read the primary voltage 2.4 on the C scale.

$$E_p = 2.4 \text{ v}$$

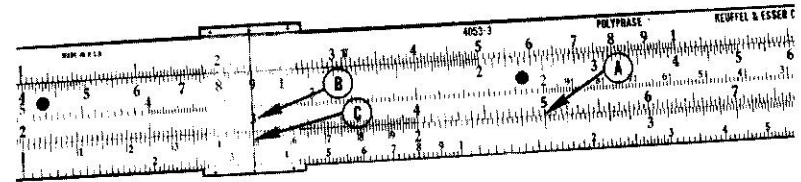

Fig. 7-1. Setting for finding the secondary voltage in a transformer, when the turns ratio and the primary voltage are given.

Example 3.

The current ratio is

$$N_p/N_s = I_s/I_p$$

If a 1-to-5 turns ratio transformer has a primary current of 2 amp, what is the secondary current?

$$1/5 = I_s/2$$

- (a). Set the right-hand C scale index over 5 on the D scale [(D) of Fig. 7-2].
- (b). Set the hairline over 2 on the D scale [(E) in Fig. 7-2].
- (c). Read the current 0.4 amp on the C scale [(E) in Fig. 7-2].

$$I_s = 0.4 \text{ amp}$$

EXERCISE 7-1

- (1). A transformer has a turns ratio of 3 to 5. What is the secondary voltage when 45 v is impressed across the primary?
- (2). A 5-to-2 turns ratio transformer has a primary current of 0.12 amp. What is the secondary current?
- (3). A power transformer has 200 turns in the primary and is rated at 110 v rms. If 400 v rms is measured across the secondary, what is the turns ratio?
- (4). A transformer with a turns ratio of 3 has 12 v at 0.6 amps in the primary. What is the voltage and current at the secondary?

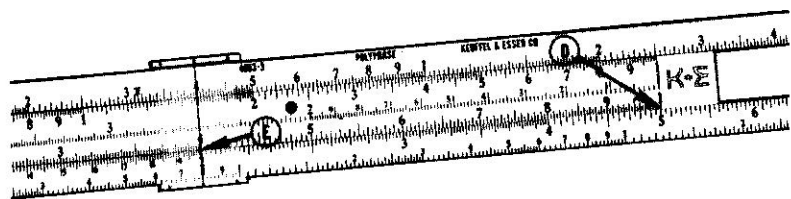

Fig. 7-2. Setting for finding the secondary current in a transformer, when the turns ratio and the primary current are given.

(5). A 6.3 v filament transformer has 110 v at its primary. The primary has 250 turns. How many turns are in the secondary?

(6). If a transformer has a secondary consisting of 300 turns, and 10 v is developed across it when the input to the primary is 150 v, how many turns are there to the primary?

8

INDUCTIVE REACTANCE AND CONTINUED PRODUCTS

8-1. Inductive Reactances

IN many problems of electronics it is often necessary to perform a series of multiplications. These are called "continued products." An example of a continued product is the equation of inductive reactance

$$X_L = 2\pi fL$$

Example 1.

Assume a 1.5-h coil is connected into a circuit to be operated at 60 cps. What is the value of inductive reactance?

$$X_L = (6.28)(6)(1.5)(10)$$

Estimate the answer to be about $6 \times 6 \times 2$, or about 72, times 10. Perform the continued-product operation on the slide rule.

- Set the right-hand C scale index over 6.28 on the D scale [(A) in Fig. 8-1].
- Set the hairline over 6 on the C scale [(B) in Fig. 8-1]. *Note:* The product of 6.28 and 6 appears on the D scale. However, this value can be disregarded.
- Without moving the hairline, slide the left-hand C scale index under the hairline [(C) in Fig. 8-2].
- Move the hairline over 1.5 of the C scale [(D) in Fig. 8-2].
- Read the answer on the D scale under the hairline [(D) in Fig. 8-2].

$$(6.28)(60)(1.5) = 563 \text{ ohms}$$

As a general rule, any continued product such as (a) (b) (c) . . . (n) can be formulated as follows.

- Set the hairline over (a) on the D scale.
- Slide the index of the C scale under the hairline.
- Move the hairline over (b) on the C scale.

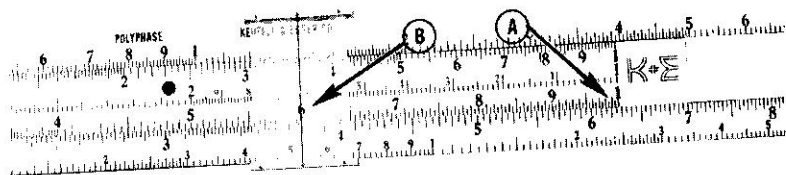

Fig. 8-1. First setting on the slide rule, for finding inductive reactance.

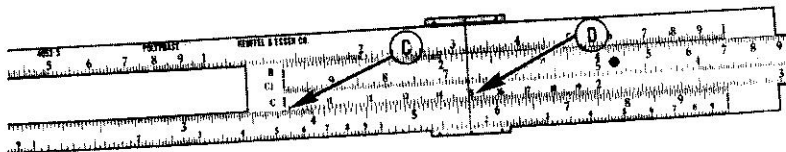

Fig. 8-2. Second setting on the slide rule, for finding inductive reactance.

- Slide the index of the C scale under the hairline.
- Move the hairline over (c) on the C scale.
- Slide the index of the C scale under the hairline.

As an exercise, apply the general rule just stated to the following problem. See if you can come up with an answer of 720.

$$6! = 1 \times 2 \times 3 \times 4 \times 5 \times 6$$

The term $6!$ is read "factorial six" and means a product series as shown above.

Example 2.

If a 200-mh coil is connected in a receiver and the operating frequency is 17 Mc, what is the inductive reactance of the coil?

$$X_L = 2\pi fL$$

$$X_L = 6.28 \times 17 \times 10^6 \times 200 \times 10^{-3}$$

Change all quantities to standard form.

$$X_L = 6.28 \times 1.7 \times 2 \times 10^7 \times 10^{-1}$$

Combine the powers of ten and estimate the answer of the standard form quantities (about 24). Perform the combined operation on the slide rule as follows:

- Set the right-hand C scale index over 6.28 on the D scale.
- Set the hairline over 2 on the C scale.
- Slide the left-hand C scale index under the hairline.
- Set the hairline over 1.7 of the C scale.
- Read the answer on the D scale under the hairline.

$$X_L = 2.13 \times 10^7$$

EXERCISE 8-1

- | | |
|-------------------------------|-----------------------------------|
| (1). (3.2) (6.4) (8.11) | (6). (0.5) (0.8) (0.4) (0.3) |
| (2). (0.07) (0.97) (0.0088) | (7). (0.9) |
| (3). (597) (860) (17) (440) | (8). (0.45 meg) (175 K) (1.5 meg) |
| (4). (56 K) (43) (109) (10 K) | (9). (7!) (4!) |
| (5). (8.77) (0.087) (0.887) | (10). (2430) (6540) (56) |
| | (10). 5.76^3 |

8-2. Word Problems

EXERCISE 8-2

- A coil of 2 h is connected to a power source of 60 cycles. What is the inductive reactance?
- How much more inductive reactance does a coil of 0.8 mh offer to 10 kc than does a 0.1-mh coil to 5 kc?
- Two coils are connected in series across a 400-cycle source of power. The first coil has an inductance of 12 h and the second has an inductance of 8. What is the total inductive reactance of the circuit.
- An equation for power is given as $P = I^2R$. The equation could be written as $P = I \times I \times R$ and worked as a continued product problem. What power is developed across a resistor of 680 ohms when 2.34 ma is flowing through it?
- What increase in power is measured in Problem 4 when the current is increased by 1 ma?
- A variable coil is tuneable across a range of frequencies. If the center tuning point represents a frequency of 17.4 kc and an inductance of 0.54 mh, what is the inductive reactance?

(7). The Q of a coil is given as $Q = X_L/R$. If a coil of 18 mh is to operate at 500 kc and has a resistance of 47 ohms, what is the Q of the coil? (Solve first for X_L .)

(8). Refer to Problem 7. If the frequency of operation were doubled, what would the new value of the Q of the coil be?

9

IMPEDANCE AND THE B SCALE

9-1. Inductance-Resistance Circuits

THE impedance of a circuit containing a resistance and inductance is given as

$$Z = \sqrt{R^2 + X_L^2}$$

The C, D, and B scales provide a short-cut answer when it is not necessary to know the angle involved. A 6-ohm resistor in series with a coil whose reactance is 7 ohms would produce a total impedance of 9.24 ohms.

Example 1.

$$Z = \sqrt{R^2 + X_L^2}$$

- Set the left-hand C scale index over 6 on the D scale [(A) in Fig. 9-1].
- Set the hairline over 7 on the D scale [(B) in Fig. 9-1].
Note: the number under the hairline on the B scale is 1.36. [(C) in Fig. 9-1]. If 1 were added to the number it would be 2.36.
- Now, move the hairline (without changing the position of the slide) over 2.36 on the B scale [(D) in Fig. 9-1].
- Read the impedance Z on the D scale [(E) in Fig. 9-1].

$$Z = 9.24$$

Example 2.

$$Z = \sqrt{(8)^2 + (11)^2}$$

Estimate the answer to be about 15. Estimating the answer in problems such as these is simplified by the fact that the answer will always be greater than the largest number (in this case greater than 11), and less

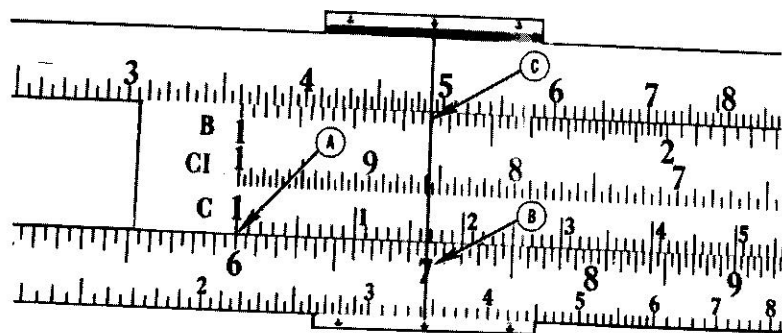

Fig. 9-1. First setting on the slide rule for finding impedance in an inductance-resistance circuit.

than the sum of the two numbers (in this case less than $8 + 11$, or 19).

- (a). Set the right-hand C scale index over 8 on the D scale.
- (b). Set the hairline over 11 on the D scale. Note the number under the hairline on the B scale (1.89) and add (1) to it (2.89).
- (c). Set the hairline over 2.89 on the B scale and read the answer on the D scale.

$$Z = 13.6$$

Example 3. $Z = \sqrt{(9.6)^2 + (17.1)^2}$

An estimate of the answer should be between 10 and 26.

- (a). Set the right-hand C scale index over 9.6 of the D scale.
- (b). Set the hairline over 17.1 on the D scale. Note the number (3.175) on the B scale under the hairline.
- (c). Slide the hairline over $3.175 + 1$ or 4.175 and note the answer on the D scale.

$$Z = 19.6$$

The student should attempt to work the problem of Example 3 starting out with the *left-hand* C scale index. The problem cannot be worked in this manner.

In *all* problems of this type it is mandatory that in the *first step* the C scale index be set on the *smaller* of the two numbers. In Example 2 if the C scale index were set on 11 first and then the hairline of 8 on the D scale, incorrect results would be obtained. Remember, in the first step the

C scale index is placed over the *smaller* of the two numbers. If the number under the B scale is in the right half of the rule — for example in finding the impedance of $R = 2$, and $X_L = 7$, — the number under the hairline is read as a two digit number, (i.e. 12.3). Adding 1 and moving the hairline to the 13.3 yields the result on the D scale, 7.28.

EXERCISE 9-1

Solve for the impedance Z.

- (1). $R = 5$, $X_L = 7$
- (2). $R = 14.6$, $X_L = 9.4$
- (3). $R = 0.462$, $X_L = 2.1$
- (4). $R = 7.07$, $X_L = 7.02$
- (5). $R = 1 \text{ K}$, $X_L = 4.5 \text{ K}$

(6). The windings of a 60-cycle choke coil have an inductance 0.9 h and a d-c resistance of 100 ohms. What is the total impedance?

(7). If the choke in Problem 6 were operated at 400 cps, what would

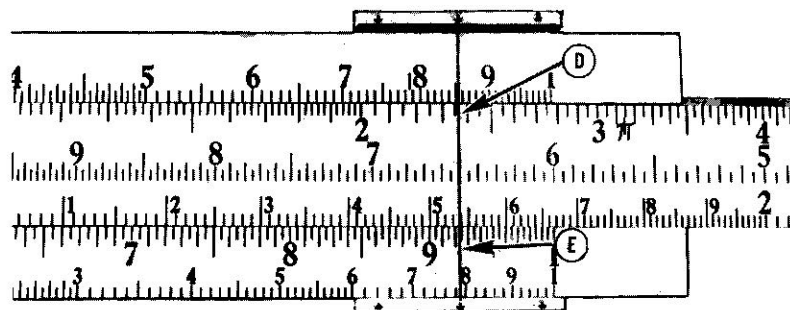

Fig. 9-2. Second setting on the slide rule for finding the total impedance.

be the new impedance?

(8). A series circuit consisting of a 0.50-h coil and a 100-ohm resistor has an impedance of how many ohms at 60 cps?

(9). If the frequency of Problem 8 were 25 cps what would the impedance be?

9-2. Capacitance-Resistance Circuits

The impedance of a circuit containing a resistance and capacitive reactance is given as

$$Z = \sqrt{R^2 + X_c^2}$$

These problems are solved in exactly the same manner as those outlined in Sec. 9-1. Only one example is shown below.

Example 1.

A resistor of 2.7 K and a capacitor whose reactance is given as 1.55 K are connected in series. What is the total impedance of the circuit? Estimate the answer to be between 2.7 K and 4 K.

- (a). Set the left-hand C scale index over 1.55 of the D scale.
- (b). Set the hairline over 2.7 of the D scale.
- (c). Read the number 3.03 on the B scale. Slide the hairline to 1 plus 3.03 (4.03) of the B scale.
- (d). Read the answer on the D scale under the hairline.

$$Z = 3.12 \text{ K}$$

EXERCISE 9-2

Solve for the impedance Z.

- (1). $R = 46$, $X_c = 30$
- (2). $R = 148$, $X_c = 190$
- (3). $R = 0.0075$, $X_c = 0.007$
- (4). $R = 9.44 \text{ K}$, $X_c = 27 \text{ K}$
- (5). $R = 974$, $X_c = 120$
- (6). $R = 0.15 \text{ meg}$, $X_c = 800 \text{ K}$
- (7). The current in a series RC circuit with a-c applied is given as the voltage divided by the total impedance. If the resistance is 220 ohms and the capacitive reactance is 130 ohms what current will flow when 100 v is applied?
- (8). If the value of the resistance in Problem 7 is doubled, what is the new current flow?
- (9). If a resistor of 0.17 meg is connected in series with a capacitor whose reactance is 800 K, what is the total impedance of the circuit?
- (10). If the frequency in Problem 9 is increased until the new capacitive reactance is 600 K, what is the new impedance?

10

PERIOD AND THE INVERTED SCALE**10-1. Period**

THE period (T) can be defined as the time required for one periodic function to complete one full cycle. A sine wave, a square wave, a sawtooth wave, etc., are all examples of repeatable periodic changes in voltage.

A 60-cycle sine wave means that the voltage passes through 60 periods in 1 sec. One complete change, or one sine wave which would require 1/60 sec is termed a period. The equation for the period is given as:

$$T = \frac{1}{f}$$

where f is measured in cycles per second and T is measured in seconds. The period of a 60-cycle voltage is

$$\frac{1}{60} = 0.0166 \text{ sec.}$$

The period of any frequency can be read directly on the CI scale of the slide rule. Examine the CI scale and note that it is identical to the C scale except that it reads from right to left. If your slide does not have a CI scale it may have a DI scale instead. Every reference to the CI scale here is the same for the DI scale. The only change should be that references to the C in the examples will mean references to the D for those DI type rules.

Some slide rules do not contain a CI or a DI scale. In cases such as these, inverted scale operations must be handled as divisions.

Example 1. The reciprocal of 2 can be written as 1/2. To write 1/2 another way,

- (a). Set the hairline over 2 on the C scale.
 (b). Read the answer on the CI scale under the hairline.

$$\frac{1}{2} = 0.5$$

Example 2.

$$\frac{1}{400}$$

As has been shown, a good way to estimate the answer is with powers of ten. The same method should be used with reciprocals but not in the *standard form* sense. Move the decimal point all the way to the left in this case.

$$\frac{1}{0.4 \times 10^3}$$

Then bring the 10^3 above the line.

$$\frac{1 \times 10^{-3}}{0.4}$$

The answer will now be a number in the *standard form*.

- (a). Set the hairline over 4 on the C scale.
 (b). Read the answer on the CI scale.

$$\frac{1}{400} = 2.5 \times 10^{-3}$$

Example 3.

What is the period of a 265-kc signal?

$$\frac{1}{265 \times 10^3}$$

Move the decimal point all way to the left.

$$\frac{1}{0.265 \times 10^6}$$

Bring the power of ten above the line.

$$\frac{1 \times 10^{-6}}{0.265}$$

- (a). Set the hairline over 265 on the C scale.
 (b). Read the reciprocal (the period) on the CI scale.

$$3.77 \mu\text{sec}$$

EXERCISE 10-1

- | | | |
|------------|---------------|--------------|
| (1). 1/7 | (5). 1/8.7 | (9). 1/π |
| (2). 1/28 | (6). 1/46000 | (10). 1/(3π) |
| (3). 1/340 | (7). 1/0.3 | (11). 1/846 |
| (4). 1/65 | (8). 1/0.0062 | (12). 1/1642 |
- (13). The period of 1 kc is what?
 (14). A period of 8 msec represents a frequency of what?
 (15). A 455-kc IF has a period of what?

10-2. Other Reciprocal Functions

The use of reciprocal functions appears so often in electronics that only a few examples can be shown here. If two capacitors are connected in series the total capacity of the two is equal to the reciprocal of the reciprocals added together. The following equation shows the relationship.

$$C_t = \frac{1}{\frac{1}{C_1} + \frac{1}{C_2}}$$

Since in some equations it is often advantageous to show a resistance R not as a resistance, but as a conductance, the conductance G is given as the reciprocal of resistance. The student is familiar with the reciprocal relationship of the capacitive reactance.

Example 1. If a 0.2 μf capacitor and a 0.3 μf capacitor are connected in series, what is the total capacity?

$$C_t = \frac{1}{\frac{1}{0.2} + \frac{1}{0.3}}$$

- (a). Locate the reciprocal of 0.2
 (b). Set the hairline over 0.2 on the C scale.
 (c). Read the answer, 5, on the CI scale.
 (d). Set the hairline over 0.3 on the C scale.
 (e). Read the answer, 3.33, on the CI scale.
 (f). Add 5 and 3.33 and take the reciprocal of the sum.

$$C_t = 0.12 \mu\text{f}$$

Example 2. If a 15-μf capacitor is connected into a circuit whose ω is 377, what is the capacitive reactance?

$$X_c = 1/\omega c$$

where ω is equal to $2\pi f$

$$X_c = 1/(3.77)(10^2)(1.5)(10^{-5})$$

Using powers of ten and applying the rules of exponents, the problem can be written

$$X_c = \frac{1 \times 10^3}{(3.77)(1.5)}$$

Multiply out the denominator. $(3.77)(1.5) = 5.66$

- (a). Set the hairline over 5.66 on the D scale. (The hairline should already be over 5.66 of the D scale as a result of multiplying out 3.77 and 1.5.)
- (b). Read answer on the DI scale.

$$X_c = 177$$

Example 3. In a series circuit, the resistive component is given as 1.77 K. The circuit represents a conductance of how many mhos?

$$G = 1/R$$

$$G = 1/(1.77)(10^3)$$

$$G = (10^{-3})/1.77$$

- (a). Set the hairline over 1.77 on the C scale.
- (b). Read the answer on the CI scale.

$$G = 0.566 \text{ mmhos}$$

EXERCISE 10-2

- (1). What is the conductance of an 800-ohm resistor?
- (2). If two capacitors of 250 μf and 450 μf are connected in series, what is the total capacitance of the circuit?
- (3). A capacitor of 0.5 μf is connected into a circuit whose frequency is 1200 cycles. What is its capacitive reactance?
- (4). If a circuit has a total conductance of 13 $\mu mhos$, what is the circuit's resistance?
- (5). A circuit has an admittance of 50 mmhos. If admittance is given as the reciprocal of impedance, find the impedance of the circuit.
- (6). A 12-, a 14-, and a 23-ohm resistor are all connected in parallel. Using the reciprocal formula, find the total resistance of the circuit.
- (7). A square wave has a period of 120 μsec . What is the pulse-repetition rate (frequency) of the signal?

11

POWER GAIN AND THE L SCALE

11-1. Logarithms

THE power gain in terms of decibels is given as

$$db = 10 \log (P_1/P_2)$$

where db is gain in decibels, P_1 is the power output, and P_2 is the power in.

Before attempting to solve these problems on the slide rule it is wise to review a few of the basic concepts of logarithms. The theory of logarithms may be found in any algebra or trigonometry book. The operations in the examples will assume an understanding of logarithms to the base 10.

The log of any number consists of two parts: the mantissa and the characteristic. The characteristic denotes the relative magnitude of the number whether it is in tens, hundreds, thousands, or millions. The mantissa identifies the number itself.

Example 1. $\log 400 = 2.602$

The number to the left of the decimal point (2) is the *characteristic* and the number to the right of the decimal point (602) is the *mantissa*. The characteristic was found by moving the decimal point in the original number (400) to the standard position and counting the number of places the point is moved. In this case the point was moved two places, therefore the characteristic is 2. The mantissa is found on the slide rule. Note that the L scale progresses from 0 on the left to 1 on the right [(A) in Fig. 11-1].

- (a). Set the hairline over 4 on the D scale [(B) in Fig. 11-1], or which ever scale is on the same slide rule part as the L scale.)
- (b). Read the mantissa on the L scale. (0.602)

Example 2. $\log 765000$

The characteristic is found by moving the decimal point five places to the

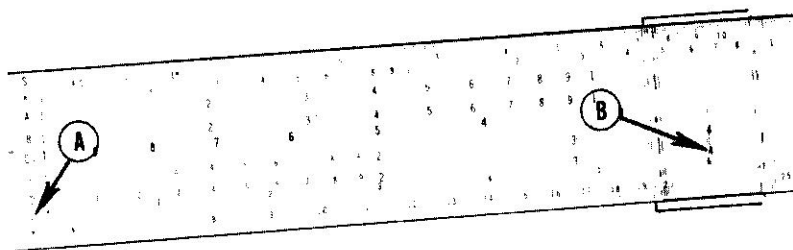

Fig. 11-1. Location of the L scale on the slide rule. The hairline shows the mantissa for the number 4.

left leaving a number in the standard form (7.65000). The number 5 then is the characteristic. The mantissa is found on the slide rule.

- (a). Set the hairline over 765 on the D scale.
- (b). Read the mantissa on the L scale. (0.884)

$$\log 765000 = 5.884$$

Example 3. $\log 0.000431$

The characteristic is found by moving the decimal point four places to the right in the original number (0004.31). This time the characteristic is a negative number (-4).

- (a). Set the hairline over 431 on the D scale.
- (b). Read the mantissa under the hairline on the L scale (0.635).

$$\log 0.000431 = -4 + 0.635$$

EXERCISE 11-1

- | | | |
|-------------------|---------------------|-----------------------------|
| (1). $\log 325$ | (5). $\log 0.00521$ | (9). $\log 45$ by 0.0000045 |
| (2). $\log 710$ | (6). $\log 1.73$ | (10). $\log 8.71$ |
| (3). $\log 56500$ | (7). $\log 0.00063$ | (11). $\log 346.2$ |
| (4). $\log 100$ | (8). $\log 0.123$ | (12). $\log 800$ |

11-2. Negative Characteristic

Few, if any, problems in logs are workable using a negative characteristic (3.712). As a result, most log problems with negative characteristics must be indicated with a positive characteristic.

Adding zero to a number does not change its value. $5 + 0 = 5$ or $0.361 + 0 = 0.361$; the values are unaltered by the addition of zero. Zero may take on many forms, as in the case of adding and subtracting 10 at the same time, which amounts to adding zero to the number. $5 + 10 - 10 = 5$. Logs with negative characteristics have 10 added and subtracted simultaneously to the characteristic without changing the numerical value of the number (the mantissa).

$$\begin{array}{r} -3.712 \quad + \quad 0 \\ 10 \quad \quad - \quad 10 \\ \hline 7.712 \quad - \quad 10 \end{array}$$

The number $7.712 - 10$ is $\bar{3}.712$ represented with a positive characteristic.

Example 1. $\log 0.00531$

The log of 0.000531 with a negative characteristic is $-3 + 0.725$. Adding and subtracting 10 to and from the characteristic,

$$\begin{array}{r} -3 + 0.725 \quad + \quad 0 \\ 10 \quad \quad - \quad 10 \\ \hline 7.725 \quad - \quad 10 \end{array}$$

Example 2. $\log 0.463$

$$\begin{array}{r} \log 0.463 = -1 + 0.666 \\ = -1 + 0.666 + 0 \\ +10 \quad \quad - \quad 10 \\ \hline 9.666 - 10 \end{array}$$

Example 3. $\log 5.91 \times 10^{-5}$

$$\begin{array}{r} \log 5.91 \times 10^{-5} = -5 + 0.7222 + 0 \\ 10 \quad \quad - \quad 10 \\ \hline 5.772 - 10 \end{array}$$

Note that when taking the log of a number with a power of 10, if the number has its decimal in the natural position, the characteristic is the exponent of the power of ten.

EXERCISE 11-2

Find the log of the following numbers and indicate with a positive characteristic.

- | | |
|--------------------|----------------------------------|
| (1). log 0.0056 | (6). log 0.9 |
| (2). log 0.0319 | (7). log 763 |
| (3). log 3.36 | (8). log 1.7×10^{-8} |
| (4). log 0.0000761 | (9). log 2.3×10^4 |
| (5). log (1/35) | (10). log 8.21×10^{-12} |

11-3. Word Problems

The ratio of a power gain or loss of an electronic device is expressed in decibels. The following examples show a few practical applications of the log scale.

Example 1. An amplifier produces 25 w output when 12.5 mw is applied to the input. What is the decibel gain or loss of the amplifier?

$$\begin{aligned} \text{db} &= 10 \log (P_o/P_i) \\ \text{db} &= 10 \log (25/0.0125) \\ \text{db} &= (10) (\log 2000) \\ \text{db} &= (10) (3.301) \\ \text{db gain} &= 33.01 \end{aligned}$$

Example 2. An attenuator network has 0.006 w developed at the output when 10 mw is developed at the input. What is the decibel gain or loss of the attenuator?

$$\begin{aligned} \text{db} &= (10) (\log 0.006/0.01) \\ \text{db} &= (10) (\log 0.6) \end{aligned}$$

The log of 0.6 becomes 9.7779 - 10

Subtracting results in (- 0.221)

$$\begin{aligned} \text{db} &= 10 (-0.221) \\ \text{db} &= -2.21 \text{ (a loss)} \end{aligned}$$

Example 3. The input power to a stage of amplification is 12.7 mw while the power output is 130 mw. What is the decibel gain of the stage?

$$\begin{aligned} \text{db} &= 10 \log (130/12.7) \\ \text{db} &= 10 \log 10.22 \\ \text{db} &= 10 (1.010) \\ \text{db} &= 10.1 \text{ gain} \end{aligned}$$

EXERCISE 11-3

(1). If 2 w output from an amplifier is obtained when 0.7 w is applied to the input, what is the decibel gain of the stage?

(2). An attenuation network produces 8 mw output when 17 mw is applied at the input. What is the decibel gain or loss of the network?

(3). If a mobile receiving antenna develops 0.071 mw for a given position, then develops 0.09 mw when the mobile antenna is moved closer to the transmitter, how much decibel gain is represented?

(4). What difference in decibel gain would be detected if 1 mw input were applied to a 10-w amplifier compared to 1 mw applied to a 15-w amplifier? (Assume that each of the amplifiers are driven to maximum when 1 mw is applied.)

(5). In a stereo amplifier, one channel produces 8 w output when 5 mw is applied at the input. What is the decibel gain of the one channel?

12

PHASE ANGLE AND THE T SCALE

12-1. Tangent Function

If a coil and a resistor are connected together in series across an a-c source there will be a phase difference between the current and the applied voltage. The actual number of degrees of difference will depend upon the size of the resistor relative to the inductive reactance of the coil.

Notice that in Fig. 12-1 a series circuit consists of an inductor and a resistor. The applied voltage is e_a . Assume that the values of the coil and resistance are such to cause the current to lag by 40° . This lagging current is shown in the figure as i_i and is displaced in the graph by 40° from the applied voltage. Since the voltage developed across a resistor must always be in phase with the current flowing through it, the graph of this voltage is shown as e_r and is in phase with the current. It follows then, that the voltage across the resistor is lagging the applied voltage by 40° also.

The current-voltage relationship across a pure inductor is a difference of 90° with the current lagging, hence the voltage leads the current by 90° . The voltage e_L shown in the figure is leading the current i_i by 90° . With e_a as the original reference it can be seen that the voltage across the inductor is leading the applied voltage by 50° .

If the inductive reactance (X_L) is equal to the resistive value then the phase angle is 45° . If the X_L is greater than R (the reactive component offers the greatest opposition to the current flow) then the phase angle will be nearer 90° . If R is large compared to X_L , then the phase angle will be closer to 0° . (The circuit looks more like a pure resistance to the current flow.) Figure 12-2(A) shows the phase angle ϕ when the

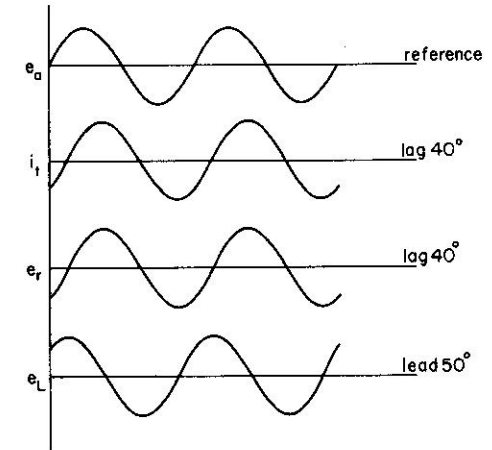
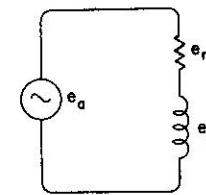

Fig. 12-1. Voltage and current waveforms of a resistor-inductor circuit.

reactance is equal to the resistance. In Fig. 12-2 (B), X_L is three times greater than R . In Fig. 12-2 (C), X_L is one-third of the value of R . Note the relative phase angles.

The actual phase angles can be found by using the tangent function of right-triangle trigonometry.

$$\tan \phi = (\text{opp/adj})$$

$$\tan \phi = (X_L/R)$$

The number of degrees can be found on the T scale in conjunction with the C or D scale.

Locate the T scale on your slide rule. Notice that the right-hand index has the number 45 above it. Now read slowly to the left until you reach

the next numbered marker. There are two numbers next to the marker: * to the right the number 40 and to the left the number 50. This pattern continues along the scale with the numbers to the left of the markers increasing and the numbers to the right decreasing. Actually, there are two scales in one. The first scale, moving from left to right, provides angles from 6° to 45° . The second scale, the same as the first, but pro-

* A few types of slide rules, generally those with the T scale on the stock, will not have the reverse set of numbers inscribed on the scale. In this case the only number found on the rule at the marker is 40. The angle for the reverse direction is the forward number subtracted from 90. In this case $90-40$ gives the correct right-to-left angle, 50° .

gressing from right to left, provides angles from 45° to 84°. Angles below 6° and above 84° cannot be read on this scale.

Given the tangent function of an angle, the corresponding angle or arc-tangent can be found in the following manner.

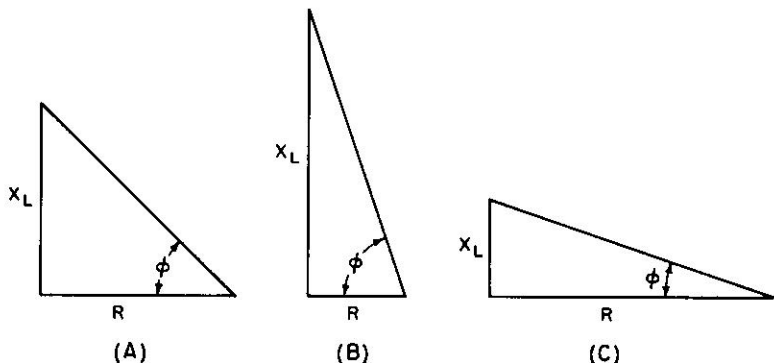

Fig. 12-2. Impedance triangles. (A) $X_L = R$, (B) $X_L = 3 \times R$, (C) $X_L = R/3$.

- (1). If the function is less than 1, set its value on the D scale. The C scale may be used if the stock and the slide are aligned.
- (2). Read the angle on the left-to-right portion of the T scale.
- (3). If the function is greater than 1 but less than 10, set its value on the CI or the DI scale.
- (4). Read the angle on the right-to-left portion of the T scale.

Example 1. A series circuit consists of a resistance of 150 ohms and an inductive reactance of 75 ohms.

$$\tan \phi = (X_L/R)$$

$$\tan \phi = (75/150) = 0.5$$

- (a). Set the hairline over 5 on the C scale.
- (b). Read the angle on the T scale. (left-to-right portion)

$$\phi = 26.58^\circ$$

Example 2. The inductive reactance of a coil is 37.5 K. The series resistance is 50 K. What is the phase angle between the current and the applied voltage?

$$\tan \phi = (X_L/R) = 37.5/50 = 0.75$$

Handwritten calculation: $\cos \phi = \frac{50}{62.5} = 0.8$

- (a). Set the hairline over 0.75 on the C or D scale.
- (b). Read the angle on the left-to-right portion of the T scale.

$$\phi = 36.85^\circ$$

Example 3. A 1000-ohm resistor in series with a coil whose reactance is 5000 ohms will produce what phase angle?

$$\tan \phi = 5000/1000 = 5$$

- (a). Set the hairline over 5 on the CI or the DI scale.
- (b). Read the angle on the right-to-left portion of the T scale.

$$\phi = 78.68^\circ$$

EXERCISE 12-1

The following problems refer to a series resistor and coil. Calculate the phase angle for each.

- | | |
|---|--|
| (1). $X_L = 45$, $R = 68$ | (8). $X_L = 56.9 \text{ K}$, $R = 56.9 \text{ K}$ |
| (2). $X_L = 1.7 \text{ K}$, $R = 3 \text{ K}$ | (9). $X_L = 699$, $R = 570$ |
| (3). $X_L = 7.98 \text{ K}$, $R = 5.7 \text{ K}$ | (10). $X_L = 8.94$, $R = 10.6$ |
| (4). $X_L = 410$, $R = 588$ | (11). $X_L = .0086$, $R = .0174$ |
| (5). $X_L = 3.99 \text{ K}$, $R = 11 \text{ K}$ | (12). $X_L = 157$, $R = 19$ |
| (6). $X_L = 75 \text{ K}$, $R = 9.7 \text{ K}$ | (13). $X_L = 13$, $R = 1.34$ |
| (7). $X_L = 7.88$, $R = 60$ | (14). $X_L = 654$, $R = 457$ |
| (15). $X_L = 45 \text{ K}$, $R = 190 \text{ K}$ | |

12-2. Tangent Functions When T Scale Is On The Stock

These examples apply to slide rules with the T scale on the stock. Such slide rules often have CI or DI scales included. The examples below give directions for those without the inverted scales. If the slide rule has its T scale on the stock and *does* have a CI or DI scale refer to the examples of Sec. 12-1 after completing the examples of Sec. 12-2.

Example 1. A series circuit consists of a resistance of 150 ohms and an inductive reactance of 75 ohms.

$$\tan \phi = (X_L/R) = 75/150 = 0.5$$

- (a). Set the hairline over 5 on the D scale.
- (b). Read the angle on the T scale.

$$\phi = 26.58^\circ$$

Example 2. A 1000-ohm resistor is in series with a coil whose reactance

is 5000-ohms. What is the phase angle by which the current lags the applied voltage?

$$\tan \phi = 5000/1000 = 5$$

- Set 5 of the C scale over either index of the D scale [(A) in Fig. 12-3].
- Set the hairline over the index of the C scale [(B) in Fig. 12-3].

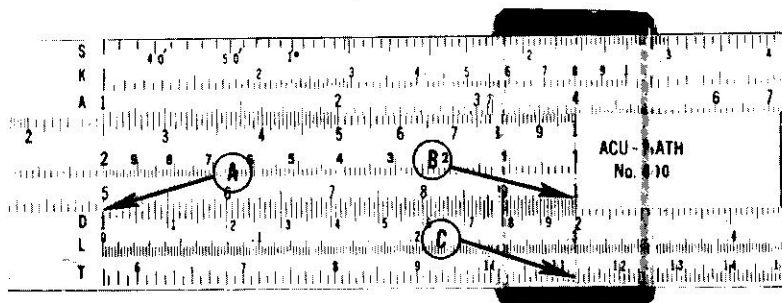

Fig. 12-3. Setting on slide rule to obtain phase angle of a resistor inductor circuit.

- Read an angle (11.32°) on the T scale [(C) in Fig. 12-3].
 - Subtract the angle read on the T scale from 90° .
- The resultant is the desired angle.

$$\phi = 90 - 11.32 = 78.68^\circ$$

Example 3. A coil whose reactance is 9.5 K has a d-c resistance of 1 K. What is the phase-angle factor for this coil?

$$\tan \phi = 9.5/1 = 9.5$$

- Set 9.5 of the C scale over either index of the D scale.
- Set the hairline over the C scale index.
- Read the angle on the T scale (6°).
- Subtract this angle from 90° for the resultant angle.

$$\phi = 90 - 6 = 84^\circ$$

Refer to the problems of Exercise 12-1 for additional practice in operating the slide rule using the T scale.

12-3. Tangent Functions of Angles

Often the phase angle of a given circuit is known and it becomes neces-

sary to find the function of the angle. Finding the tangent function of a known angle involves the opposite operation of finding the angle from the known function (known as "finding the arc function").

Example 1. $\tan 35^\circ$

- Set the hairline over on the left-to-right portion of the T scale.
- Read the function on the C or D scale.

$$\tan 35^\circ = 0.7$$

Example 2. $\tan 74^\circ$

- Set the hairline over 74 on the right-to-left portion of the T scale.
- Read the answer on the CI or the DI scale.

$$\tan 74^\circ = 3.48$$

Example 3. $\tan 51^\circ$

- Set the hairline over 51 on the right-to-left portion of the T scale.
- Read the answer on CI or DI scale.

$$\tan 51^\circ = 1.235$$

EXERCISE 12-3

Give the tangent functions for the following angles.

- | | | | |
|--------------------|-------------------|---------------------|---------------------|
| (1). 41° | (6). 14° | (11). 69° | (16). 71° |
| (2). 14.7° | (7). 55.8° | (12). 7.55° | (17). 6.4° |
| (3). 7° | (8). 74.9° | (13). 51.15° | (18). 45° |
| (4). 11.11° | (9). 81° | (14). 66.6° | (19). 43° |
| (5). 44.55° | (10). 62° | (15). 8.6° | (20). 84.15° |

(21). Assume that a circuit consisting of a resistor and an inductor has a phase angle of 30° and the resistor reads 250 ohms. What is the value of the inductive reactance in ohms?

(22). In the circuit of Problem 21, the phase angle is known to be 42° and the resistor color code reads brown, blue, brown. What is the inductive reactance in ohms?

(23). In Problem 22, how much would the value of the resistor have to be changed to make the phase angle 45° ?

(24). Four different frequencies are applied to the circuit of Problem 21. At each frequency the phase angle doubles; 10° , 20° , 40° , and 80° . The resistor is a fixed value of 17 K. What were the changes in X_L ?

13

IMPEDANCE AND THE S SCALE

13-1. The S Scale

A TRIGONOMETRIC function used in solving problems in alternating-current circuits is the sine function. Figure 13-1 shows a right triangle with references to an angle ϕ . The hypotenuse is equal to Z , while the side of the triangle opposite the angle is shown as X . The side touching the angle ϕ is called the "adjacent side" and is known as R .

$$\sin \phi = \text{opp/hyp}$$

$$\sin \phi = X/Z$$

Before actually applying these functions it will be necessary to learn the use of the S scale on the slide rule. Begin by examining the S scale carefully. Note that the left end of the scale is similar to the T scale (on most rules numbers appear to both the left and the right of the markers). For the present we will deal with only the numbers to the right of the markers.

13-2. The Sine Function

Examine the triangle in Fig. 13-1. Assuming the value of R remains constant and the reactive component (X) is made larger or smaller, the impedance (Z) and the phase angle (ϕ) will vary as X varies. This function, known as the arc-sine function, will be useful in determining the value of the impedance.

Given the sine function, the corresponding angle can be found on the slide rule by the following process.

- (1). Set the sine function on the D scale.
- (2). Read the angle on the left-to-right portion of the S scale.

Example 1. $\sin \phi = 0.143$

- (a). Set the hairline over 0.143 on the D scale [(A) in Fig. 13-2].

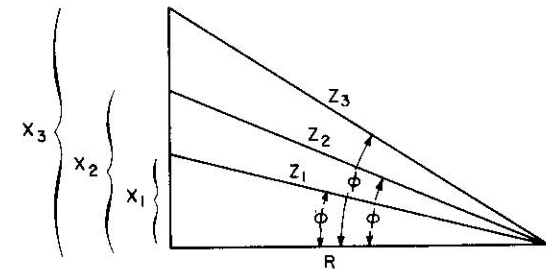

Fig. 13-1. Impedance triangle, keeping R constant, and varying X and ϕ .

- (b). Read the angle under the hairline on the left-to-right portion of the S scale [(B) in Fig. 13-2]

$$\phi = 8.2^\circ$$

Example 2. $\sin \phi = 0.1246$

- (a). Set the hairline over 0.1246 on the D scale.

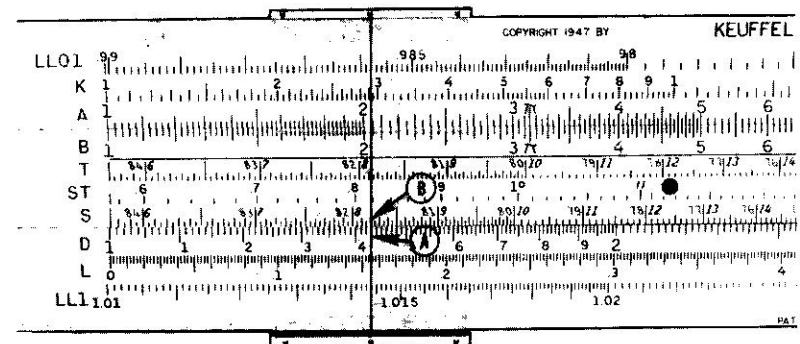

Fig. 13-2. Setting on slide rule to obtain the angle whose sine is 0.143.

- (b). Read the angle under the hairline on the left-to-right portion of the S scale.

$$\phi = 7.1^\circ$$

$$\sin 7.1^\circ = 0.1246$$

Example 3.

$$\sin \phi = 0.98$$

- (a). Set the hairline over 0.98 on the D scale.
 (b). Read the angle under the hairline on the left-to-right portion of the S scale.

$$\phi = 78.6^\circ$$

EXERCISE 13-2

Using the slide rule, identify the angles (arc-sines) corresponding to the following sine functions.

- | | | | |
|------------|-------------|-------------|-------------|
| (1). 0.650 | (6). 0.57 | (11). 0.707 | (16). 0.798 |
| (2). 0.458 | (7). 0.5 | (12). 0.9 | (17). 0.248 |
| (3). 0.119 | (8). 0 | (13). 0.850 | (18). 0.108 |
| (4). 0.871 | (9). 0.405 | (14). 1.0 | (19). 0.593 |
| (5). 0.950 | (10). 0.333 | (15). 0.445 | (20). 0.2 |

13-3. Sine

As with the tangent function, it is often necessary to find a function of a known angle. Here the operation is the reverse.

Example 1.

$$\sin 35^\circ$$

- (a). Set the hairline over 35 on the S scale.
 (b). Read the function directly on the C or D scale.

$$\sin 35^\circ = 0.574$$

No further examples are necessary, since all problems are very similar. Any setting of angle on the S scale will always yield a function less than 1 and greater than 1/10.

EXERCISE 13-3

Give the sine functions of the following angles.

- | | | | |
|-------------|-------------|-------------|--------------|
| (1). 41° | (6). 50.4° | (11). 45° | (16). 11.15° |
| (2). 37° | (7). 15.8° | (12). 38° | (17). 81.9° |
| (3). 58.6° | (8). 18° | (13). 68.9° | (18). 64.4° |
| (4). 71.84° | (9). 6.8° | (14). 1.0 | (19). 8° |
| (5). 40.4° | (10). 40.5° | (15). 90° | (20). 80° |

13-4. Sine Function Applied to Circuit Problems

Assume for the circuit of Fig. 13-3 the total impedance (Z) is 600 ohms and the phase angle ϕ is 38° . What is the value of the inductive reactance in the circuit?

$$\sin \phi = X/Z$$

$$\sin 38^\circ = X/600$$

$$(600) (\sin 38^\circ) = X$$

$$X_L = (600) (0.616) = 369 \text{ ohms}$$

EXERCISE 13-4

- (1). In the circuit of Fig. 13-3, if the phase angle is 58° and the impedance is 475 ohms, what is the value of the X_L ?

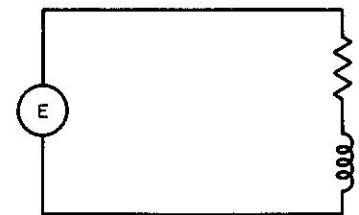

Fig. 13-3. Solving for reactance, when the total impedance and phase angle are known.

- (2). In a series L/R circuit the impedance is 587 ohms; the reactance is 457 ohms. What is the phase angle of the circuit?
 (3). Three guy wires are attached to an antenna and then secured into the ground 10 ft away from the antenna mast. If each wire is 45 ft long, what angle does each guy wire make with the antenna? Draw a picture.
 (4). In a circuit whose impedance is 155 K, the phase angle is 11° . What is the value of the reactance?
 (5). In a series L/R circuit the phase angle is 45° . The impedance is 350 ohms. What is the value of the resistance?
 (6). A 71-ft rope is stretched from the top edge of a building to a point 35 ft away. What angle does the rope make with the ground? With the building?
 (7). In a series L/R circuit, when does the reactive property equal the impedance?
 (8). In a series L/R circuit, what is the phase angle when the reactive property is equal to the impedance?

13-5. The Cosine Scale

The cosine function of an angle is given as

$$\cos \phi = \text{adj/hyp}$$

$$\cos \text{ of the phase angle} = R/Z$$

Cosine functions are also available on the S scale of the standard slide rule. Once again inspect the S scale.* Notice that to the left of the markers are a series of numbers progressing upward from right to left. The right-hand index of the S scale denotes the cosine of 0° , while at the left-hand index the largest cosine angle is given as 84° . Observe also that at the far right end of the scale no small graduations exist between 0° and 10° . The scale should not be used for angles that small; cosine tables are more accurate. A given cosine function or angle can be found in the following manner by (1) setting the cosine function of the angle on the C or D scale, and (2) reading the angle on the right-to-left portion of the S scale.

Example 1. $\cos \phi = 0.143$

- (a). Set the hairline over 0.143 on the C or D scale [(A) in Fig. 13-2].
 (b). Read the angle on the right-to-left portion of the S scale [(B) in Fig. 13-2].

$$\phi = 81.8^\circ$$

Example 2. $\cos \phi = 0.750$

- (a). Set the hairline over 0.75 on the C or D scale.
 (b). Read the angle on the right-to-left portion of the S scale.

$$\phi = 41.4^\circ$$

EXERCISE 13-5

For the following cosine functions give the corresponding angle (or arc-cosine).

- | | | | |
|------------|-------------|--------------|--------------|
| (1). 0.885 | (6). 0.950 | (11). 0.877 | (16). 0.5 |
| (2). 0.110 | (7). 0.777 | (12). 0.889 | (17). 0.1085 |
| (3). 0.305 | (8). 0.1145 | (13). 0.199 | (18). 0.447 |
| (4). 0.9 | (9). 0.895 | (14). 0.1414 | (19). 0.2 |
| (5). 0.636 | (10). 0.685 | (15). 0.707 | (20). 0.985 |

* On some slide rules no cosine functions are indicated on the rule. On these rules the S scale has only one set of numbers progressing from left to right. Refer to Sec. 13-7 for the procedure for finding cosine function.

13-6. Cosine Function

The process of finding a function for a given angle is the opposite operation of finding the angle from the function.

Example 1. $\cos 35^\circ$

- (a). Set the hairline over 35 on the S scale (right-to-left portion).
 (b). Read the function of the angle on the C or D scale.

$$\cos 35^\circ = 0.819$$

Example 2. $\cos 81.7^\circ$

- (a). Set the hairline over 81.7 on the right-to-left portion of the S scale.
 (b). Read the function of the angle on the C or D scale.

$$\cos 81.7^\circ = 0.1458$$

EXERCISE 13-6

Give the cosine functions of the following angles.

- | | | | |
|-------------------|--------------------|---------------------|--------------------|
| (1). 44.5° | (5). 71.6° | (9). 10° | (13). 15° |
| (2). 34.7° | (6). 11.15° | (10). 16.85° | (14). 8° |
| (3). 83.8° | (7). 66.87° | (11). 17.4° | (15). 50° |
| (4). 45.0° | (8). 70.7° | (12). 30° | (16). 74.9° |

13-7. Cosine Function (Unmarked Rules)

The student should study the sections devoted to the sine functions carefully. Once the operations using the sine functions have been learned, the operations with cosine functions will provide no additional difficulty. Because the functions of complementary angles are the same any cosine function can be found on the sine-function scales. The cosine of 35° is given as 0.819. The sine of 55° is also 0.819. The angles 35° and 55° are complements of each other. A general rule can be established: To find the cosine function of an angle *subtract* the angle from 90° and look up the sine function.

Example 1. $\cos 48^\circ$

- (a). Subtract 48 from 90. $90^\circ - 48^\circ = 42^\circ$
 (b). Set the hairline over 42 of the S scale.
 (c). Read the function on the C or D scale.

$$\cos 48^\circ = 0.669$$

Whenever the angle from a given function is to be found the operation is opposite of the one outlined in the preceding example.

Example 2. $\cos \phi = 0.735$

- Set the hairline over 0.735 of the D scale.
- Read the angle under the hairline on the S scale (47.3°).
- Subtract this angle from 90° . $90^\circ - 47.3^\circ = 42.7^\circ$

$$\phi = 42.7^\circ$$

The student should refer to Sec. 13-5 and 13-6 for additional practice in finding cosine functions.

EXERCISE 13-7-1

- In a series L/R circuit the resistance is given as 100 ohms and the impedance as 150 ohms. What is the phase angle?
- In the circuit of Problem 1, what would be the phase angle if the resistance were reduced one-half and the impedance remained the same?
- In a circuit the impedance is given as 350 ohms and the phase angle as 54.75° . What is the resistance in the circuit?
- If the resistance of a circuit remains the same, and different values of inductance are inserted into the circuit causing phase angles of 30° , 35° , and 40° , what impedance changes correspond to these angles?
- A rope 20 ft long is attached to a fence 10 ft high. The other end of the rope is pulled tight and touched to the ground. How many feet from the fence is the rope touched to the ground?

EXERCISE 13-7-2

Give the sine, cosine, and tangent functions for the following angles:

- | | | | |
|--------------------|--------------------|---------------------|---------------------|
| (1). 41.75° | (6). 81.98° | (11). 58.55° | (16). 34.34° |
| (2). 56.88° | (7). 31.5° | (12). 0° | (17). 58.9° |
| (3). 50.95° | (8). 54° | (13). 13.1° | (18). 45° |
| (4). 77.9° | (9). 11.11° | (14). 66.9° | (19). 61.1° |
| (5). 90° | (10). 80° | (15). 18.55° | (20). 21.11° |

EXERCISE 13-7-3

- A tree casts a shadow 41 ft long and produces an angle with the sun of 61.7° . How tall is the tree?
- From a given location, if you walked north 12 yards, east 6 yards,

and south 2 yards, on a direct line, how far would you be from your original location?

(3). If a circle whose diameter is 34.6 in has an equilateral triangle inscribed in it, what is the perimeter of the triangle?

(4). Two flag poles, one 100 ft, and one 75 ft tall, are standing 30 ft away from each other. How far from the shorter pole would an observer

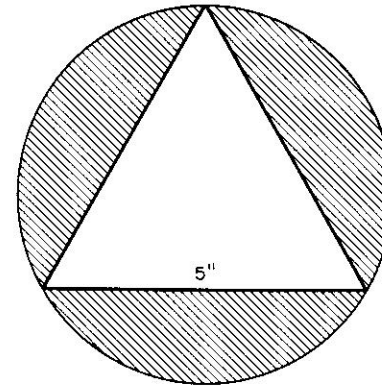

Fig. 13-4. Diagram for Problem 10, Exercise 13-8.

at ground level have to position himself so that the larger pole is obscured by the smaller pole? (*Hint*: draw a picture.)

- At what angle does the cosine function equal the sine function?
- If an $8\frac{1}{2}$ -by-11-in sheet of paper is folded diagonally, how long will the fold be?
- A circuit consists of an X_L of 455 ohms, and a resistance of 500 ohms. Find the impedance and the phase angle.
- An observer on a 400-ft-high cliff sights a ship at sea. The angle of depression to the ship is 11.75° . How many miles is the ship at sea from the observer?
- A rectangle 2 in \times 4 in is inscribed into an equilateral triangle. What is the perimeter of the triangle?
- Find the shaded area in Fig. 13-4. (Each side of the triangle is 5 in.)

14

POLAR-TO-RECTANGULAR
TRANSFORMATION

14-1. Notation

THE circuit of Fig. 14-1 exhibits a total impedance which can be identified in the form discussed in Chaps. 12 and 13. Stating it in this form, the total impedance of the circuit is about 36 ohms.

For simple series circuits of this type, expressing the impedance in this way is sufficient. However, when circuits become complex simple methods of solving for the network impedance fail.

The actual solution of such complex circuits is not the purpose of this book, however the fundamentals necessary for learning solutions are a knowledge of polar-to-rectangular transformation and the rectangular-to-polar transformation.

As has been stated earlier, the total impedance of the simple circuit shown in Fig. 14-1 is about 36 ohms. This total impedance can be expressed in one of two ways; by polar notation or by rectangular notation. The polar notation indicates an impedance vector and the number of degrees it is rotated from the reference axis. For example, the impedance of the circuit of Fig. 14-1 represented by polar notation is

$$Z_t = 36 \angle 56.30$$

Stated, the total impedance of the network is 36 ohms at an angle of

+ 56.3°. The rectangular notation of an impedance consists of an indication of the individual resistive and reactive property of the circuit. For example, the impedance of the circuit of Fig. 14-1 represented by rectangular notation is

$$Z_t = 20 + j30$$

The +j is used to indicate the inductive reactive property of the circuit. Whenever a capacitive reactance is present in the circuit (such as a series

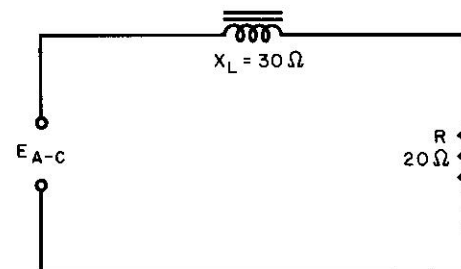

Fig. 14-1. Resistance and inductance in an a-c circuit.

resistor and capacitor) a minus j precedes the reactive property. This simple rule of thumb applies to all circuits, whether they are series, parallel, or a combination series-parallel. Plus j indicates inductive reactance, while minus j indicates capacitive reactance. It should be remembered that these impedances mean the same thing.

$$36 \angle 56.30 = 20 + j30$$

The two different forms of expressing the same impedance are needed for simplifying the processes of solving complex circuits. In general it is simpler to add and subtract rectangular forms of the impedance, and to multiply and divide polar forms.

14-2. Rectangular Addition

In adding together impedances indicated in their rectangular form, the resistive properties are added arithmetically while all the reactive properties are added algebraically.

Example 1. A series circuit consists of a resistor of 45 ohms and a capacitor whose reactance is 40 ohms. If an inductor whose reactance is

10 ohms is added in series with the circuit, what is the total impedance of the circuit in its rectangular form?

$$Z_t = (45 - j40) + (0 + j10)$$

$$\begin{array}{r} 45 - j40 \\ 0 + j10 \\ \hline Z_t = 45 - j30 \end{array}$$

The answer in Example 1 is in its rectangular form. If the polar form of the same impedance were required for a particular mathematical operation,

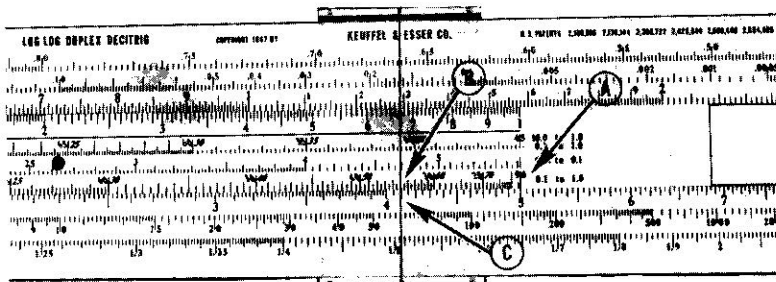

Fig. 14-2. Slide rule setting for the resistive part of the impedance in a circuit.

tion, it would be necessary to transform from rectangular to polar form (covered in Chap. 15).

14-3. Transformation to Rectangular Form

Example 1. Find the rectangular equivalent of the impedance $50 \angle 35^\circ$

- Set the right-hand slide index over 50 on the D scale [(A) in Fig. 14-2].
- Set the hairline over 35 (angle) on the cosine scale [(B) in Fig. 14-2].
- Read the resistive property on the D scale under the hairline: 40.95 ohms [(C) in Fig. 14-2].
- Without changing the position of the slide move the hairline over 35° of the sine scale [(D) in Fig. 14-3].
- Read the reactive property under the hairline on the D scale: $X_L = 28.65$ ohms [(E) in Fig. 14-3].
- $50 \angle 35^\circ = 40.95 + j28.65$ (The plus j is indicated because of the positive angle in the polar form.)

Example 2. Find the rectangular equivalent of the impedance $125 \angle -51.5^\circ$

- Set the left-hand C scale index over 125 on the D scale.
- Set the hairline over 51.5° on the cosine scale.

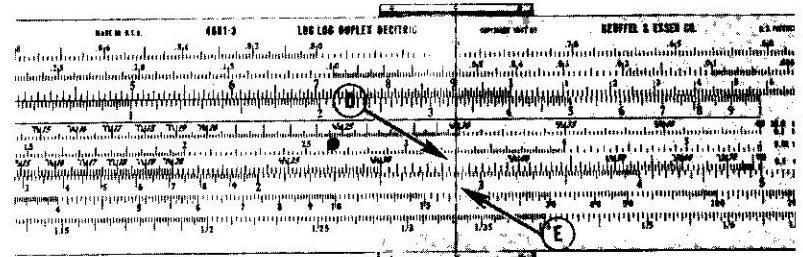

Fig. 14-3. Slide rule setting for the reactive component of the impedance in a circuit.

- Read the resistive property on the D scale, under the hairline ($R = 77.85$).
- Without changing the position of the slide move the hairline over 51.5° on the sine scale.
- Read the capacitive reactive property on the D scale under the hairline ($X_C = 97.9$ ohms).
- $125 \angle -51.5^\circ = 77.85 - j97.9$ (The $-j$ is indicated because the angle in the polar form is negative).

Example 3. Transform to its rectangular equivalent the polar impedance $25 \angle 20.4^\circ$

- Set the right-hand C scale index over 25 on the D scale.
- Set the hairline over 20.4 of the cosine scale.
- Read the resistive property on the D scale ($R = 23.42$ ohms).
- In this problem it is necessary to change the C scale index in order to locate the hairline over the angle on the sine scale. Hence, before proceeding with the problem set the left-hand index of the C scale over 25 on the D scale.
- Set the hairline over 20.4 on the sine scale.
- Read the reactive property on the D scale under the hairline ($X_L = 8.72$ ohms).
- $25 \angle 20.4^\circ = 23.42 + j8.72$

EXERCISE 14-3

Convert the following polar-form impedances to their rectangular equivalents.

- (1). $50 \angle 36.9^\circ$ (5). $0.004 \angle -15^\circ$ (9). $150 \angle 90^\circ$
 (2). $120 \angle -60^\circ$ (6). $135 \angle 77.8^\circ$ (10). $4.07 \angle -0^\circ$
 (3). $1.6 \angle 43.5^\circ$ (7). $65 \angle 80^\circ$ (11). $12 \angle -45^\circ$
 (4). $5 \text{ K} \angle 50^\circ$ (8). $1.45 \text{ K} \angle -42.7^\circ$ (12). $6.55 \times 10^4 \angle 28^\circ$

(13). A series circuit has a total impedance of 50 ohms at 63.7° . What is the value of the resistance in the circuit?

(14). A simple series circuit has a total impedance of $67 \angle 26.6^\circ$. Another similar circuit has a total impedance of $108 \angle 56.3^\circ$. Which of these two circuits has the larger resistor?

(15). An impedance of $500 \angle -40^\circ$ is represented by a circuit which has a capacitor in series with a resistor. If the circuit has a 200-kc voltage applied, what is the value of the capacitor?

(16). If 20 v is applied across a circuit whose impedance is $380 \angle 40^\circ$, what voltage is developed across the resistor?

(17). In the circuit of Problem 16, what voltage is developed across the coil if 60 v is applied?

14-4. Polar-to-Rectangular Transformation (Special Rules)

Many of the new slide rules, domestic as well as the imported, have the S scale on the stock. Polar-to-rectangular transformation is performed in the manner previously defined, with one exception. In the preceding example the resistive value was found to correspond to the cosine function of ϕ and the reactive value to correspond to the sine function of ϕ . In this case the resistive value corresponds to the complement of the sine of ϕ and the reactive to the sine of ϕ , the complement of ϕ being that angle which together with ϕ equals 90° .

$$\text{complement} = 90 - \phi$$

The complement of 36° would be $\phi = 90 - 36^\circ = 54^\circ$.

Example 1. An impedance of $65 \angle 49^\circ$ has an equivalent rectangular impedance of $42.6 + j49$.

- (a). Set 65 of the C scale over the right-hand D scale index.
 (b). Set the hairline over 49 of the S scale.
 (c). Read the inductive reactance on the C scale under the hairline (+ $j49$).
 (d). Move the hairline over the complement of 49° (41°).

- (e). Read the resistive property on the C scale under the hairline (42.6 ohms).

Example 2.

Change $150 \angle 25^\circ$ to rectangular form.

- (a). Set 150 of the C scale over the left-hand D scale index.
 (b). Set the hairline over 25 of the S scale.
 (c). Read the reactance on the C scale under the hairline 63.3.
 (d). It is necessary in this problem to switch to the opposite D scale index. Reset 150 of the C scale over the right-hand D scale index.
 (e). Set the hairline over 65 (complement of 25°) on the S scale.
 (f). Read the resistive property on the C scale under the hairline (136).

$$150 \angle 25^\circ = 95.3 + j97.7$$

EXERCISE 14-4

Change to rectangular form.

- (1). $88 \angle 53^\circ$ (6). $120 \angle 15^\circ$
 (2). $55 \angle -70^\circ$ (7). $1.7 \text{ K} \angle 63.4^\circ$
 (3). $0.86 \angle 26.3^\circ$ (8). $1.85 \text{ meg} \angle 12^\circ$
 (4). $0.091 \angle 80^\circ$ (9). $6 \times 10^{-3} \angle 55.8^\circ$
 (5). $141.4 \angle -45^\circ$ (10). $146 \angle 151^\circ$

15

RECTANGULAR-TO-POLAR TRANSFORMATION

15-1. Vector Division

If an a-c voltage is applied to the circuit of Fig. 13-3, the total current flow can be calculated by dividing the applied voltage by the total impedance of the circuit. This process is sufficient if the magnitude of the current is the only factor required. Often, however, it is necessary to know whether this current leads or lags the applied voltage, and by how many degrees. Once again the total voltage is divided by the total impedance, but this time angles are included in the division. The basic equation for the current is

$$I_t = \frac{E \angle \theta}{Z \angle \phi}$$

In polar form division the magnitudes are divided while the angle of the denominator is subtracted from the angle of the numerator. The equation then becomes

$$I_t = \frac{E \angle \theta - \phi}{Z}$$

Although the *j* operator was introduced in Chap. 14, its importance warrants further description here. The total impedance of the circuit shown in Fig. 13-3 is defined in terms of the *j* operator. ($Z_t = R + jX$) Expressed in this way the impedance is in its rectangular form. If it were to be substituted into the equation above in order to calculate the

current, the operations necessary would be involved and difficult. If however, that same impedance were expressed in its polar form, the operations would be as shown above. The impedance in its polar form is expressed as $Z_t = Z \angle \theta$. The objective then, is to transform rectangular impedance to its polar form. This process can be accomplished on the

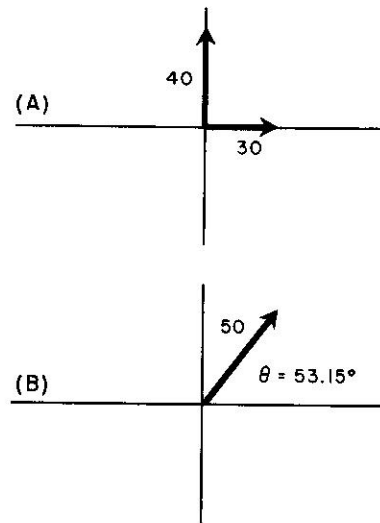

Fig. 15-1. (A) Vector representatives of resistance and inductive reactance. (B) Polar vector equivalent to (A).

slide rule in two operations. The scales used are the D, T, and S. The *j* operator as used in the rectangular form indicates two things: an imaginary factor similar to (*i*) (in formal mathematics indicated as $\sqrt{-1}$), and a vector rotated 90° plus or minus from the reference.

15-2. Vector Addition

The operations just described could also be termed "vector addition." If the resistive property of a circuit is defined as a force acting in a circuit and the reactance is defined as a second force, then these two together result in the absolute impedance of the circuit. Figure 15-1(A) shows a resistive vector of 30 and a reactive vector of 40. The inductive reactive property is such that it acts at an angle of 90° with respect to the resistance. The equivalent impedance or the vector sum, is shown in Fig. 15-1(B). Remember that the impedance shown in Fig. 15-1(A) ($Z = R$

+ jX) is exactly the same as the impedance shown in Fig. 15-1(B) ($Z_t = Z / \phi$). In order to develop skill and proficiency in making rectangular to polar transformations the technician should be able to work all the problems in Chaps. 12 and 13 before attempting to understand the operations here.

15-3. Transformations

Example 1. Assume that in the circuit of Fig. 14-1, the frequency of the applied voltage is such that the inductive reactance $X_L = 40$ ohms.

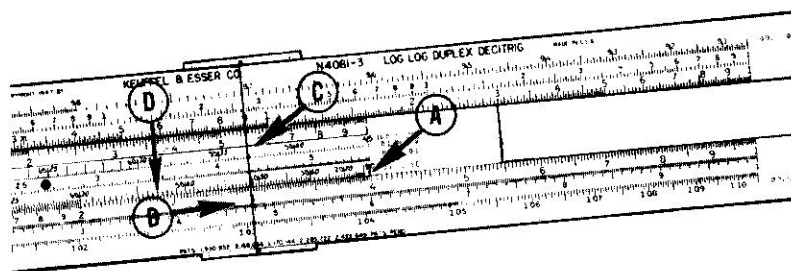

Fig. 15-2. Slide rule setting — Step 1 in finding the total current in an a-c circuit.

If the value of the resistor is 30 ohms and the applied voltage is 50 v, what total current will flow in the circuit and by how many degrees will it lead or lag the applied voltage?

The equation for the current is

$$I_t = \frac{E}{Z} \quad I_t = \frac{50 \angle 0^\circ}{30 + j40}$$

The impedance ($30 + j40$) must now be transformed into its polar form.

- Set the 90° index of the S scale over the larger of the two numbers (40) on the D scale [(A) in Fig. 15-2].
- Set the hairline over the smaller number (30) on the D scale [(B) in Fig. 15-2].
- Read the angle under the hairline on the T scale. [(C) in Fig. 15-2]. Notice here that there are two angles under the hairline, 36.85° and 53.15° . By examining the rectangular form vectors, shown in Fig. 15-1, the inductive reactive component is larger than the resistive component; hence the angle is greater than 45° .

- Without moving the hairline simply locate 53.15° on the cosine scale [(D) in Fig. 15-2].
- After finding the angle 53.15° on the cosine scale, slide that angle under the hairline. (The hairline should not have been moved. If it was, start over and repeat the process.) [(E) in Fig. 15-3].

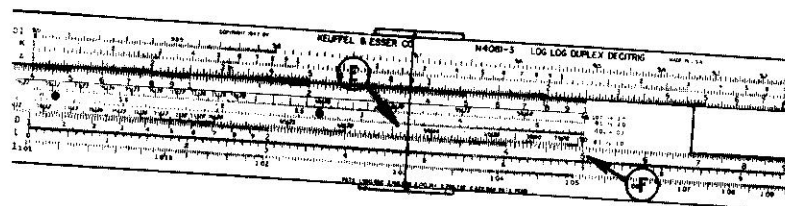

Fig. 15-3. Step 2 in finding the total current.

- Read the polar form of the impedance ($50 \angle 53.15^\circ$) under the 90° index on the D scale [(F) in Fig. 15-3].

The problem is now half completed. The original problem asked to find the current and its lead or lag angle compared to the applied voltage. We can now substitute into the original equation for current the polar form of the impedance.

$$I_t = \frac{50 \angle 0^\circ}{50 \angle 53.15^\circ}$$

$$I_t = \frac{50}{50} \angle 0^\circ - (53.15^\circ)$$

$$I_t = 1 \text{ amp} \angle -53.15^\circ$$

Example 2. Express the impedance $63.7 - j46$ in its polar form.

- Set the 90° index over the larger number (63.7) on the D scale.
- Set the hairline over the smaller number (46) on the D scale.
- Read the angle (35.7°) on the T scale. (Examining the vectors, the resistive component is larger and the reactive component is smaller, so the angle is less than 45° .)
- Without moving the hairline, locate 35.7° on the sine scale. (The sine scale is used whenever the angle is less than 45° and the cosine scale whenever it is greater.)
- Slide 35.7° of the sine scale under the hairline.
- Read the polar form of the impedance on the D scale.

$$63.7 - j46 = 78.7 \angle -35.7^\circ$$

A negative j factor indicates a negative angle. The equivalent series circuit of Example 2 would consist of a resistor of 63.7 ohms and a capacitor whose reactance is 46 ohms.

Example 3.Express $130 - j71$ in its polar form.

- (a). Set the left-hand S scale index over 130 on the D scale, the larger of the two numbers [(A) in Fig. 15-4].

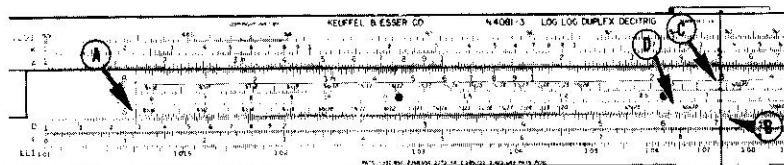

Fig. 15-4. First slide rule setting in converting from rectangular to polar form.

- (b). Set the hairline over 71 on the D scale [(B) in Fig. 15-4].
 (c). Read the angle 28.75° under the hairline on the T scale [(C) in Fig. 15-4].
 (d). Without moving the hairline, locate 28.75° on the sine scale [(D) in Fig. 15-4]. (The angle is less than 45° .)
 (e). Slide 28.75° of the sine scale under the hairline [(E) in Fig. 15-5].
 (f). Read the impedance on the D scale under the index [(F) in Fig. 15-5].

$$130 - j71 = 148 / 28.75^\circ$$

15-4. Summing Up

When changing from rectangular form to polar form, set the S scale index over the larger number on the D scale, set the hairline over the

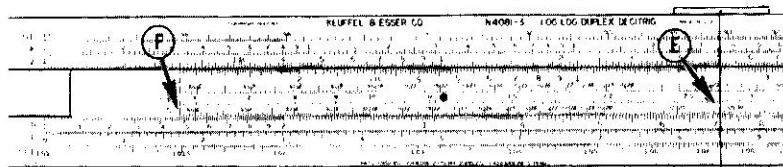

Fig. 15-5. Second setting in the conversion from rectangular to polar forms.

smaller number on the D scale, and read the angle on the T scale. If

R is greater than X , the angle is less than 45° . If R is smaller than X , the angle is greater than 45° . Slide the angle from the sine or cosine scale under the hairline, the sine scale if the angle is less than 45° . Read the impedance on the D scale under the S scale index.

EXERCISE 15-4

In the following problems, change the rectangular forms to their polar forms, indicating both the impedance and the angle.

- (1). $43 + j59$ (4). $13.7 - j0$ (7). $4 - j65$
 (2). $12.7 - j54.9$ (5). $0.81 + j2.7$ (8). $23.5 - j23.5$
 (3). $0.075 + j1.116$ (6). $0 - j43.8$ (9). $43.6 + j33.3$

(10). A series circuit, consisting of a resistor of 10 ohms and an inductance of 12 mh has 100 v at 60 cycles applied. By how many degrees will the current lag the applied voltage?

(11). In the circuit of Problem 10, if the frequency of the applied signal is increased to 120 cps, what change in the phase angle between the current and voltage will occur?

16

THE NATURAL BASE ϵ

THE base of the natural system of logarithms is 2.71828. . . .

Because this number appears in many equations of electronics and physics the lower-case Greek letter epsilon (ϵ) is used to symbolize the entire number. It is considerably easier to carry this letter (instead of 2.71828) through a series of equations than to write a series of digits each time the quantity appears.

In many equations it is often necessary to raise ϵ to an exponent: $e = E\epsilon^{-x}$. In reality this means the number $(2.71828)^3$, $(2.71828)^{-1.3}$ or $(2.71828)^{0.7}$. It is possible to solve for these values by using the system of logarithms to the base ten. This method is at best cumbersome. The fastest method consists of one setting on the duplex log-log slide rule.

16-1. ϵ Raised to a Positive Exponent

On almost all slide rules, the log-log scales are divided into two groups. ϵ raised to a positive exponent (ϵ^{+x}) is generally found on one group of scales, while ϵ raised to a negative exponent (ϵ^{-x}) is found on a different set of scales. The treatment in this section is for positive exponents; Sec. 16-5 covers negative exponents.

Examine the log-log scales of the slide rule. On most rules these scales are identified as LL1, LL2, and LL3. On the LL1 scale the lowest numbers appear at the left end. The number there should be approximately 1.01 and the number at the right should be about 1.1. Now notice the LL2 scale at the left-hand margin. It begins with 1.1 at the left and ends at about 2.7 at the right. The LL3 scale begins at about 2.7 at its left end and extends to about 20,000 at the right. Actually, the log-log scale is one

long scale divided into three sections for practical operations. On some slide rules an additional scale (LL4) has been added. This additional scale provides a wider range of operation, or an effectively longer log-log scale. When such an additional scale is provided on the rule the LL1 scale starts at a number lower than 1.01 and the LL4 scale ends at a number higher than 20,000. The range varies with different makes of rules.

When reading from the log-log scales, check your reading for accuracy. The graduations between significant markings differ. As an ex-

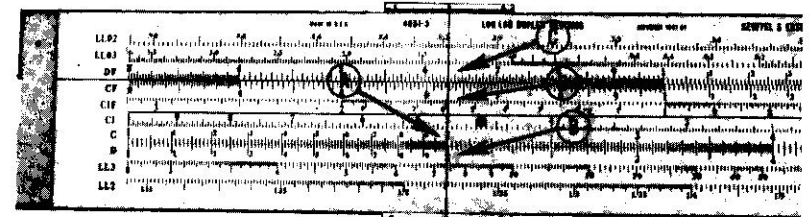

Fig. 16-1. Setting for finding $\epsilon^{2.0}$ on the log-log scale.

ample, notice on the LL3 scale the number of secondary graduations between the 7 and 8 setting on the D scale. Now examine the LL1 scale and notice the difference in the marking between the same 7 and 8 settings of the D scale.

16-2. The LL3 Scale

If ϵ is raised to an exponent which has its decimal in the standard position (or standard form), the value of the exponent is located on the C or D scale and the answer is read on the LL3 scale.

Example 1. $\epsilon^{2.0}$

- Set the hairline over 2 on the C or D scale. [(A) in Fig. 16-1].
- Read the answer under the hairline on the LL3 scale. [(B) in Fig. 16-1]. If the LL3 scale is divided into a set of readings on the top half and a different set of readings on the bottom half, the answer to this problem is found on the top half.

$$\epsilon^{2.0} = 7.38$$

Example 2. $\epsilon^{1.09}$

- Set the hairline over 1.09 on the C or D scale.

- (b). Read the answer on the LL3 scale under the hairline.

$$\epsilon^{1.00} = 2.97$$

Example 3.

$$\epsilon^{7.6}$$

- (a). Set the hairline over 7.6 on the C or D scale.
 (b). Read the answer under the hairline on the LL3 scale.

$$\epsilon^{7.6} = 2000$$

Summing up: Whenever the decimal point in the exponent of ϵ is in the standard form (Chap. 3) the answer is always on the LL3 scale. For slide rules with an LL4 scale the answer will be on the LL4 scale, but the original settings must be made on the DFM scales.

EXERCISE 16-2

- (1). ϵ^3 (3). $\epsilon^{8.5}$ (5). $\epsilon^{1.05}$ (7). $\epsilon^{1.125}$ (9). ϵ
 (2). $\epsilon^{2.5}$ (4). $\epsilon^{7.74}$ (6). ϵ^1 (8). $\epsilon^{9.93}$ (10). ϵ^5

16-3. The LL2 Scale

If ϵ is raised to an exponent which has its decimal point one place to the left of the standard position, place the value of the exponent on the C or D scale and read the answer on the LL2 scale.

Example 1.

$$\epsilon^{0.7}$$

- (a). Set the hairline over 7 on the C or D scale.
 (b). Read the answer under the hairline on the LL2 scale.

$$\epsilon^{0.7} = 2.015$$

Example 2.

$$\epsilon^{0.105}$$

- (a). Set the hairline over 1.05 on the C or D scale.
 (b). Read the answer under the hairline on the LL2 scale.

$$\epsilon^{0.105} = 1.111$$

Example 3.

$$\epsilon^{0.45}$$

- (a). Set the hairline over 4.5 on the C or D scale.
 (b). Read the answer under the hairline on the LL2 scale.

$$\epsilon^{0.45} = 1.567$$

Summing up: Whenever the decimal point (in the exponent) is one place to the left of the standard position, the answer is on the LL2 scale.

EXERCISE 16-3

- (1). $\epsilon^{0.2}$ (3). $\epsilon^{0.3}$ (5). $\epsilon^{0.71}$ (7). $\epsilon^{0.1}$ (9). $\epsilon^{0.631}$
 (2). $\epsilon^{0.81}$ (4). $\epsilon^{0.34}$ (6). $\epsilon^{0.5}$ (8). $\epsilon^{0.9}$ (10). $\epsilon^{0.404}$

16-4. The LL1 Scale

If ϵ is raised to an exponent which has its decimal point two places to the left of the standard position, the exponent is placed on the C or D scale, and the answer is read directly on the LL1 scale.

Example 1.

$$\epsilon^{0.07}$$

- (a). Set the hairline over 7 on the C or D scale.
 (b). Read the answer on the LL1 scale.

$$\epsilon^{0.07} = 1.0724$$

Example 2.

$$\epsilon^{0.084}$$

- (a). Set the hairline over 8.4 on the C or D scale.
 (b). Read the answer on the LL1 scale.

$$\epsilon^{0.084} = 1.0875$$

Example 3.

$$\epsilon^{0.01155}$$

- (a). Set the hairline over the 1.155 on the C or D scale.
 (b). Read the answer on the LL1 scale.

$$\epsilon^{0.01155} = 1.0116$$

Summing up: Whenever the decimal point in the exponent is two places to the left of the standard position, the answer is always on the LL1 scale.

EXERCISE 16-4

- (1). $\epsilon^{0.02}$ (3). $\epsilon^{0.081}$ (5). $\epsilon^{0.044}$ (7). $\epsilon^{0.091}$ (9). $\epsilon^{0.07}$
 (2). $\epsilon^{0.084}$ (4). $\epsilon^{0.01}$ (6). $\epsilon^{0.0102}$ (8). $\epsilon^{0.05}$ (10). $\epsilon^{0.021}$

16-5. ϵ Raised to a Negative Exponent

Slide rules which provide reciprocal functions (of ϵ raised to a negative exponent) are divided into two basic groups. The first group consists of three or more scales labeled LL01, LL02, and LL03. (Some manufacturers consolidate these scales with the positive exponent scales. In this case the LL1, LL2, and LL3 scales are divided in half, with the top half of the scale representing the positive exponent functions and the

bottom half representing the reciprocal functions.) The second group consists of two scales marked LL0 and LL00.

Examine the reciprocal function scales on the rule. Note that LL01 (and LL0) at the left end of the scale starts with a value about 0.99. Follow this scale from left to right and notice that the numbers decrease

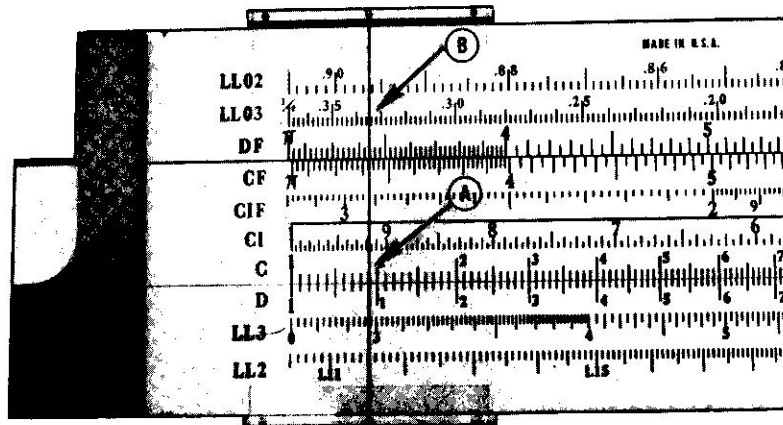

Fig. 16-2. Setting on slide rule for epsilon raised to a negative exponent.

in value. If the log-log scales are placed end to end, the numbers are continuous and decrease to a low value of about 0.0001 on the LL03 scale (LL00).

Here is a simple illustration of the interrelationship of the LL2 scale and the LL02 scale: Set the hairline over 2 on the LL2 scale. Note the value under the hairline on the LL02 scale (0.5). The scales are reciprocal functions of each other.

16-6. The LL01, LL02, and LL03 Scales

If ϵ is raised to an exponent which has its decimal in the standard position, the value of the exponent is placed on the C or D scale and the answer read on the LL03 scale. The process is the same as the one outlined in Sec. 16-2, with one change: the answer is read on the reciprocal scale.

Example 1. $\epsilon^{-1.09}$

- (a). Set the hairline over 1.09 on the C or D scale. [(A) in Fig. 16-2].

- (b). Read the answer on the LL03 scale or the LL3 bottom half [(B) in Fig. 16-2].

$$\epsilon^{-1.09} = 0.336$$

Example 2.

$$\epsilon^{-7.6}$$

- (a). Set the hairline over 7.6 on the C or D scale.
 (b). Read the answer on the LL03 scale.

$$\epsilon^{-7.6} = 0.0005$$

If ϵ is raised to an exponent which has its decimal point one place to the left of the standard position (0.45) place the value of the exponent on the C or D scale and read the answer on the LL02 scale or the LL2 bottom half.

Example 3.

$$\epsilon^{-0.45}$$

- (a). Set the hairline over 4.5 on the C or D scale.
 (b). Read the answer under the hairline on the LL02 scale.

$$\epsilon^{-0.45} = 0.636$$

If ϵ is raised to an exponent which has its decimal point two places to the left of the standard position, the value of the exponent is placed on the C or D scale and the answer read on the LL01 or LL1 bottom half scale.

Example 4.

$$\epsilon^{-0.084}$$

- (a). Set the hairline over 8.4 on the C or D scale.
 (b). Read the answer on the LL01 scale.

$$\epsilon^{-0.084} = 0.9223$$

EXERCISE 16-6

- (1). ϵ^{-2} (3). $\epsilon^{-0.43}$ (5). $\epsilon^{-0.93}$ (7). $\epsilon^{-1.1175}$ (9). $\epsilon^{-0.0105}$
 (2). $\epsilon^{-3.88}$ (4). $\epsilon^{-0.071}$ (6). $\epsilon^{-8.75}$ (8). ϵ^{-1} (10). $\epsilon^{-8.6}$

16-7. The LL0 and LL00 Scales

The LL0 and LL00 scales are reciprocal function scales. If your slide rule contains LL1, LL2, and LL3 scales it must also contain reciprocal function scales. These scales are indicated in a number of ways, for example,

LL01	1/LL1	LL0
LL02	1/LL2	LL00
LL03	1/LL3	

The method of locating the reciprocal functions, or ϵ raised to a negative exponent, are the same as those outlined in Sec. 16-5. One change is necessary. Instead of locating the exponent on the C or D scale and read-

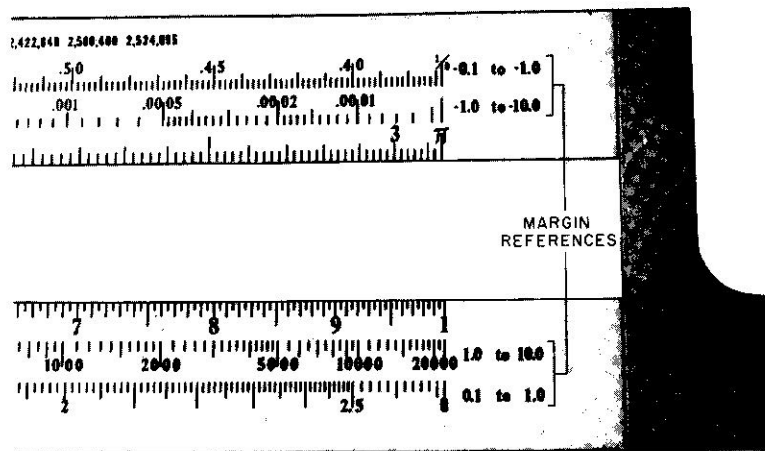

Fig. 16-3. Illustration of margin references on the log-log scales.

ing the answer on the log-log scale, here the exponent is located on the A or B scale and the answer read on the LL0 or LL00 scale.

Example 1. $\epsilon^{-1.4}$

- Set the hairline over 1.4 on the right-hand A scale.
- Read the answer under the hairline on the LL00 scale.
- $\epsilon^{-1.4} = 0.247$

Note: It is sometimes a point of confusion here as to which of the two scales (LL0 or LL00) should be used in reading the answer. Close examination of the two scales will eliminate all confusion. All slide rules with the 0 and 00 scales provide references at the margins.

Examine closely the LL0 scale. (The same applies for all types of rules). Note that at the left-hand index a set of small numerals is inscribed (-0.001): at the right-hand index of the same scale another set of numbers (-0.1). Now examine the LL00 scale and note the numbers at the left-hand index. (-0.1) This value is the value where the LL0 scale left off. At the right of the LL00 scale the number is (-10). These small numbers indicate the range of exponents readable on these two scales. ϵ raised to any exponent between -0.001 to -10.0 may be read on this rule. In Example 1, ϵ was raised to an exponent of -1.4 . This

value falls between the values listed for the LL00 scale. Figure 16-3 illustrates margin references for the LL2, LL3, LL02, and LL03 scales.

Example 2. $\epsilon^{-0.14}$

- Set the hairline over 1.4 of the left-hand A scale. (In Example 1, ϵ was raised to a -1.4 exponent and the right-hand A scale was used).
- Read the answer under the hairline on the LL00 scale.

$$\epsilon^{-0.14} = 0.869$$

Example 3. $\epsilon^{-0.005}$

- Set the hairline over 5 of the left-hand A scale.
- Read the answer under the hairline on the LL0 scale.

$$\epsilon^{-0.005} = 0.995$$

Refer to Exercise 16-6 for practice problems.

17

RC CIRCUITS

IN the circuit of Fig. 17-1 current begins to flow the instant the switch is closed. The current flow decreases rapidly as the capacitor becomes charged to the applied voltage. The time required for the capacitor to become fully charged depends upon the values of the resistor and the capacitor.

Often it becomes necessary to know the *exact* voltage across the capacitor at given time after the switch is closed. The voltage across the capacitor is

$$e_c = E(1 - e^{-t/RC})$$

where

e_c = the instantaneous voltage across the capacitor

E = the maximum applied voltage

R = the resistance in ohms

C = the capacitance in farads

t = the given instant of time

Example 1. Assume a maximum voltage of 100 v (E) is applied to the circuit of Fig. 17-1. The resistor is 2 megohms and the capacitor is 0.5 μ f. What is the value of the voltage across the capacitor (e_c) 0.1 sec after the switch is closed? What is it 2 sec after the switch is closed?

$$\begin{aligned} e_c &= 100 [1 - e^{0.1/(2)(10^6)(0.5)(10^{-6})}] & e_c &= 100 (1 - e^{-2/1.0}) \\ &= 100 (1 - e^{-0.1/1.0}) & &= 100 (1 - e^{-2}) \\ &= 100 (1 - e^{-0.1}) & &= 100 - 100 (0.135) \end{aligned}$$

$$\begin{aligned} e_c &= 100 - 100 e^{-0.1} \\ &= 100 - 100(0.9) \\ &= 10 \text{ v (when } t = 0.1 \text{ sec)} \end{aligned}$$

$$\begin{aligned} e_c &= 100 - 13.5 \\ &= 86.5 \text{ v (when } t = 2 \text{ sec)} \end{aligned}$$

By Kirchhoff's law, the voltage across the resistor when $t = 2$ sec must

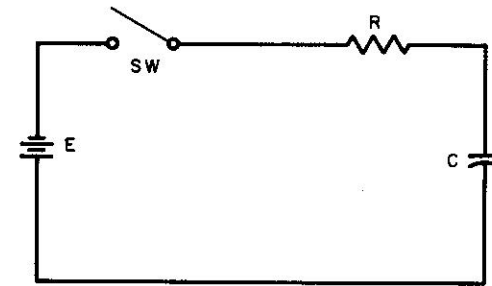

Fig. 17-1. Circuit demonstrating charging effects of a capacitor.

be the applied voltage minus e_c of 86.5 v, or 13.5 v. The voltage across the resistor can be found by the equation

$$e_r = E (e^{-t/RC})$$

where e_r = the voltage across the resistor.

E = the maximum applied voltage

R = the resistance in ohms

C = the capacitance in farads

t = the given instant of time

EXERCISE 17-1

(1). A series RC circuit consisting of a resistance of 1 megohm and a capacitance of 0.4 μ f has a maximum d-c voltage applied of 70 v. What will the voltage across the capacitor be 0.15 sec after the voltage is applied? What will the voltage across the resistor be 1 sec after the voltage is applied?

(2). In the circuit of Problem 1, double the value of the resistance in the circuit and calculate the two voltages for the same given times.

(3). In the circuit of problem, 1 increase the value of the capacitor to 0.8 μ f and calculate the two voltages for the same given times.

(4). In a series RC circuit, 10 v is applied to a resistance of 500 K and capacitance of 0.01 μ f. What will the voltages across the capacitors be 10, 20, and 30 msec after the voltage is applied? Why is the voltage

difference between 10 and 20 msec different from the difference between 20 and 30 msec?

(5). In series RC circuits, what factors control the instantaneous voltage across a capacitor?

(6). The charge on a capacitor (in coulombs) is

$$q = CE (1 - e^{-t/RC})$$

where

q = quantity of charge in coulombs

C = capacity in farads

R = resistance in ohms

t = the given time in seconds

Calculate the amount of charge on a capacitor, 45 μf , 25 msec after an

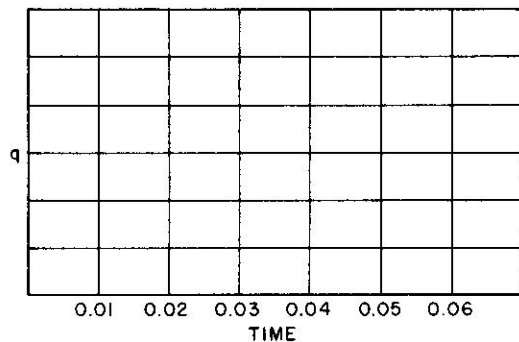

Fig. 17-2. Graph for plotting charge of a capacitor.

80-v d-c potential is applied. The resistance of the circuit is 1800 ohms.

(7). In the series circuit of Problem 1, what will the quantity of charge in coulombs be 1 sec after the voltage is applied?

(8). In the series circuit of Problem 1, what will the instantaneous value of the voltage across the capacitor be 1 sec after the voltage is applied?

(9). A series circuit consists of a resistor of 1000 ohms and a capacitor of 50 μf . When 100 v d-c is applied, plot the quantity of charge for five segments of time. Use the graph in Fig. 17-2.

(10.) What relation exists between the quantity of charge and the instantaneous voltage?

(11). In a series circuit consisting of a resistor of 200 K and a capaci-

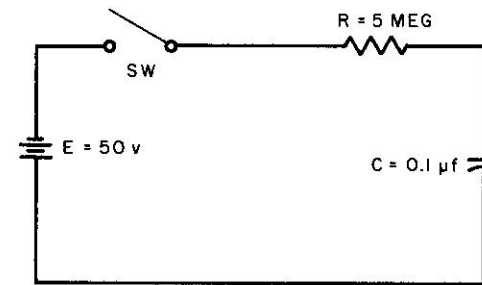

Fig. 17-3. Circuit for Problem 13, Exercise 17-1.

tor of 0.01 μf , a d-c voltage of 100 v is applied. How long after the voltage is applied will the voltage across the capacitor reach 40% of the applied voltage? (*Hint*: Solve for t in the instantaneous voltage equation)

(12). In the circuit of Problem 6 what is the current flow the instant voltage is applied?

The instantaneous value of current in an RC circuit is given by

$$i = \frac{E}{R} (e^{-t/RC})$$

where

E = the maximum applied voltage

i = the instantaneous value of current in amperes

C = the capacity in farads

R = the resistance of the circuit in ohms

t = the given time in seconds

(13). In the circuit of Fig. 17-3 what is the instantaneous value of current 0.1 sec after the switch is closed?

(14). In the circuit of Fig. 17-3, what is the instantaneous value of current the instant the switch is closed?

(15). In the circuit of Fig. 17-3, what will the instantaneous value of the voltage across the resistor be 0.8 sec after the switch is closed?

(16). In the circuit of Fig. 17-3, what will the quantity charge in coulombs be 0.5 sec after the switch is closed?

(17). In the circuit of Fig. 17-3, at what time (t) will the current in the circuit decay to 20% of the maximum current flow?

(18). If the battery of Fig 17-3, were removed and the two wires of the circuit were connected together how long would it take for the capacitor to discharge completely?

(19). In the circuit of Fig. 17-3, what will the voltage across the resistor be 0.25 sec after the switch is closed?

18

INDUCTIVE REACTANCE AND THE
FOLDED SCALES

INDUCTIVE reactance as given in Chap. 8 was solved by a series of continued products. The equation is

$$X_L = 2\pi fL$$

and as a continued product becomes

$$X_L = (2) (3.1416) (f) (L)$$

Using the C and D scales of an ordinary slide rule such a multiplication involves four operations. Using the folded scales of a slide rule (CF and DF) reduces the number of operations to two.

Examine the CF and DF scales. Notice that the left-hand index begins with 3.1416. Moving along the scale to the right the numbers increase (in the same way as the C scale) to 10 at about the middle of the scale. Continuing to the right we start at 1 and progress to 3.1416 again at the right-hand index. This scale is in reality a C scale which has been folded at 3.1416, and is useful for multiplying by π .

Example 1. Before solving a typical problem using the folded scales, attempt a multiplication involving π . We know that π multiplied by 2 is approximately 6.28. Multiply 2 times 3.1416 in the usual manner on the C and D scales. Note the time required in setting the hairline over 3.1416. (Some slide rules without CF and DF scales provide a marker at π on the C and D scales.

(a). Set the hairline on 2 of the D scale. [(B) of Fig. 16-1].

(b). Under the hairline on the DF scale, note the answer 6.28 [(C) of Fig. 16-1].

Example 2. 8.4π

Estimate the answer to be about 8×3 or 24.

(a). Set the hairline over 8.4 on the D scale.

(b). Under the hairline, read the answer on the DF scale.

$$8.4\pi = 26.39$$

Example 3. 0.0072π

Using the powers of ten, move the decimal point of 0.0072 to the right three places and note that the answer will have a 10^{-3} product. Now estimate the answer to about $7 \times 3 \times 10^{-3}$, or about 21×10^{-3} .

(a). Set the hairline over 7.2 on the D scale.

(b). Under the hairline read the answer on the DF scale.

$$0.0072\pi = 22.61 \times 10^{-3}$$

EXERCISE 18-1

- | | |
|-----------------|------------------------------|
| (1). 4π | (6). $0.8\pi \times 10^{-8}$ |
| (2). 3.6π | (7). 1.11π |
| (3). 120π | (8). 56.9π |
| (4). 0.075π | (9). 0.0052π |
| (5). 88.6π | (10). π^2 |

18-2. Folded Scales and Combined Operations

In combined operations involving inductive reactance an additional setting of the hairline is required. Only one additional setting is assumed because the constant 2 is always multiplied by π in the equation. The operator should mentally multiply one of the other constants by 2 and then continue with the problem.

Example 1. $2\pi 4$

In this example the factor 2 is mentally multiplied by the factor 4, and the answer is estimated to be about 8×3.1416 or approximately 24.

(a). Set the hairline over 8 on the D scale.

(b). Read the answer under the hairline on the DF scale.

$$2\pi 4 = 25.15$$

Example 2. $(2.6)(8.1)\pi$

In this example there is no constant multiplier 2; hence, a combined

operation involving two operations is required. Estimate the answer to be $2 \times 3 \times 8$ or about 48.

- Set the right-hand C scale index over 2.6 on the D scale [(A) of Fig. 18-1].
- Set the hairline over 8.1 on the C scale [(B) of Fig. 18-1].

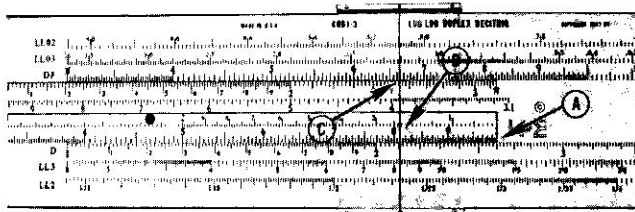

Fig. 18-1. Setting on slide rule illustrating use of DF scale.

- Read the answer under the hairline of the DF scale [(C) of Fig. 18-1].

$$(2.6)(8.1)\pi = 66.2$$

Example 3. $(8400)(62000)(\pi)$

Using power of ten, change the problem to read $(8.4)(6.2)(\pi) \times 10^7$. Estimate the answer to be $8 \times 6 \times 3$ or about 150×10^7 .

- Set the right-hand C scale index over 8.4 on the D scale.
- Set the hairline over 6.2 on the C scale.
- Read the answer under the hairline on the DF scale.

$$(8400)(62000)\pi = 163.5$$

EXERCISE 18-2

Solve each of the following problems.

- $(4)(0.5)(\pi)$
- $(3.6)(8.4)(\pi)$
- $(12)(36)(\pi)$
- $(0.004)(0.093)(\pi)$
- $(205)(806)(\pi)$
- $(0.00036)(10^{-3})(\pi)$
- $3^2\pi$
- $(2.46)(1.795)(\pi)$
- $(8.62)^2\pi$
- $4\pi^2$

18-3. Inductive Reactance

When more than two numbers are multiplied by pi, as in the case of inductive reactance, the technique is no more difficult than ordinary multi-

plication. One precaution must be observed; the π operation must *always* be the *last* operation.

Example 1. A 5-henry coil will offer how much reactive opposition to a frequency of 30 cps?

In the equation $X_L = 2\pi L$ substitute the values of the problem. $X_L = 2\pi(30)(5)$. Estimate the answer to be about $10 \times 30 \times 3$ (the 10 is combined 2×5), or about 900.

- Set the left-hand C scale index over 30 on the D scale.
- Set the hairline over the 10 on the C scale (index).
- Read the answer under the hairline on the DF scale.

$$X_L = 942 \text{ ohms}$$

EXERCISE 18-3

Solve each of the following problems.

- $2\pi(4)(9)$
- $(8.6)(2.9)(4.1)(\pi)$
- $3\pi(7000)(8400)$
- $2\pi(60)(0.0035)$
- $8^2\pi 60$
- $85000\pi(53)$
- $0.004\pi(86)(0.0059)$
- $(4\pi)^2$
- $2\pi(400)(15)$
- $5\pi(8000)(9.36)$

- A choke of 12 h will offer what reactances to 25, 60, and 400 cps?
- What difference in reactance is there between a 40-mh choke and a 35-mh choke to 20 kc.
- How much opposition does a 130- μ h choke offer to 60 cps?
- What are the inductive reactances of a 120-mh coil at the two ends of the broadcast band (550 kc — 1650 kc).
- To what frequency will a 40-mh choke offer 36,000 ohms of opposition?
- What is the inductive reactance to 60 cps of the primary of a transformer whose inductance is 8 h?

19

RATIO AND MULTIPLICATION
ON THE FOLDED SCALES

19-1. Time Saving

IN addition to providing a simplified method of solving inductive reactance problems, the CF and DF scales can be used to save time in ordinary operations. For example, if the product of 3 times 8 is set up initially using the wrong index, it is necessary to switch indices before completing the multiplication.

Set the left-hand C scale index over 3 on the D scale. Note that 8 of the C scale is off the stock. It is necessary to change to the right-hand index before completing the problem. However, if the rule contains CF and DF scales, the indices do not have to be switched. Try the same problem using the CF and DF scales.

- (a). Set the left-hand C scale index over 3 on the D scale.
- (b). Set the hairline over 8 on the CF scale.
- (c). Read the answer on the DF scale.

$$3 \times 8 = 24$$

19-2. Ratios

Using ratio as a device for solving problems of electronics is a popular technique. Transformer circuits, Ohm's law series circuits, current distributions, etc., are a few examples. The CF and DF scales provide quick answers to ratio problems.

Example 1. $\frac{8}{3} = \frac{20}{x}$

- (a). Set the 8 of the C scale over 3 of the D scale.

- (b). Set the hairline over 2 on the CF scale.
- (c). Read the answer on the DF scale.

$$x = 7.5$$

Example 2. $2 : 7 :: 4 : x$

- (a). Set the 2 of the C scale over 7 on the D scale.
- (b). Set the hairline over 4 on the CF scale.
- (c). Read the answer on the DF scale.

$$x = 14$$

Example 3. A transformer with 100% efficiency develops 11 v across the secondary when 9 v is supplied to the primary. If the secondary has 600 turns, how many turns are there in the primary? Since the turns ratio of a transformer is equal to the voltage ratio $E_p : E_s :: N_p : N_s$; it follows that $11 : 9 :: 600 : x$.

- (a). Set the 9 of the CF scale under 11 of the DF scale.
- (b). Set the hairline over 6 on the DF scale.
- (c). Read the answer on the CF scale.

$$x = 492 \text{ turns}$$

It is interesting to note that the 6 and 11 were on the same scale (DF). In a ratio problem these two numbers will always appear on the same scale. In Example 2 both the 2 and the 4 were on the C scales.

EXERCISE 19-2

- | | |
|--|--|
| (1). $\frac{8}{9.3} = \frac{x}{2}$ | (6). $\frac{11}{8} = \frac{3}{x}$ |
| (2). $\frac{0.031}{0.7} = \frac{4.6}{x}$ | (7). $\frac{12}{7} = \frac{x}{3}$ |
| (3). $\frac{x}{6.05} = \frac{1}{4.2}$ | (8). $\frac{12}{x} = \frac{13}{9}$ |
| (4). $\frac{834}{x} = \frac{1.74}{3.92}$ | (9). $\frac{0.06}{3} = \frac{94.7}{x}$ |
| (5). $\frac{1K}{x} = \frac{3.9}{4.6}$ | (10). $\frac{88.3}{62.9} = \frac{x}{0.0036}$ |

(11). A transformer has a 110-v primary winding and a 90-v secondary winding. If the primary has 84 turns, the secondary has how many turns?

(12). A transformer develops 8 v at 1 amp in the secondary when 2 amp flows in the primary. What is its turns ratio?

20

CAPACITIVE REACTANCE
AND THE CIF SCALE

THE CIF scale is an inverted CF scale. The scale is most useful for finding reciprocal functions of π . The scale is ideally suited for solving problems of capacitive reactance

$$X_c = \frac{1}{2\pi fC}$$

Example 1. Find the reciprocal of 2π . Combining operations of multiplication of the C scale with the reciprocal functions of the CIF scale eliminates one slide rule setting.

- Set the hairline over 2 on the C scale. [(A) of Fig. 16-1].
- Read the answer under the hairline of the CIF scale. [(D) of Fig. 16-1].

$$1/(2\pi) = 0.1592$$

Example 2. $1/(2\pi 3.03)$

Estimate the answer to be the reciprocal of $2 \times 3 \times 3$, or about 1/18, or about 0.05.

- Set the left-hand C scale index over 2 on the D scale.
- Set the hairline over 3.03 on the C scale.
- Align all scales but do not move the hairline.
- Read the answer under the hairline on the CIF scale.

$$1/(2\pi 3.03) = 0.0526$$

Example 3.

$$\frac{1}{(370)(952)(\pi)}$$

When estimating the answer of reciprocals involving pi, it is wise to convert all numbers, excluding pi, to numbers less than 1. In this case

$$\frac{1 \times 10^{-6}}{(0.37)(\pi)(0.952)}$$

The estimated answer is the reciprocal of $0.3 \times 3 \times 1$ or 1 divided by 0.9 or an estimated answer of about 1 times 10^{-6} .

- Set the right-hand C scale index over 952 on the D scale.
- Set the hairline over 370 on the C scale.
- Align all scales.
- Read the answer under the hairline on the CIF scale.

$$0.906 \times 10^{-6}$$

EXERCISE 20-1

Solve the following.

- | | |
|---------------------------|---------------------------------|
| (1). $\frac{1}{3\pi}$ | (6). $\frac{1}{892\pi 3000}$ |
| (2). $\frac{1}{8.9\pi}$ | (7). $\frac{1}{83\pi 127}$ |
| (3). $\frac{1}{350\pi}$ | (8). $\frac{1}{0.031\pi(0.71)}$ |
| (4). $\frac{1}{7\pi 3.6}$ | (9). $\frac{1}{\pi 2}$ |
| (5). $\frac{1}{0.004\pi}$ | (10). $\frac{1}{4.7\pi}$ |

20-2. Capacitive Reactance

The solution of capacitive reactance is similar to that of the previous problems.

Example 1. A $0.03 \mu\text{f}$ capacitor will offer how much reactive opposition to a source of 60 cps?

$$X_c = \frac{1}{2\pi fC}$$

$$X_c = \frac{1}{2\pi(60)(0.03)(10^{-6})}$$

In this problem, estimate the answer to be the reciprocal of the products of $2 \times 3 \times 60 \times 0.03$, or about $1/10$, or about 0.1 times 10^6 .

- Set the left-hand C scale index over 2 on the D scale.
- Set the hairline over 3 on the C scale.
- Slide the right-hand C scale index under the hairline.
- Set the hairline over 6 on the C scale.
- Align all scales.
- Read the answer under the hairline on the CIF scale.

$$X_c = 88.4 \text{ K}$$

Example 2.
$$X_c = \frac{1}{2\pi(25)(0.05)(10^{-6})}$$

Set the problem up using powers of ten in this manner

$$X_c = \frac{1 \times 10^5}{(2)(0.25)(0.5)\pi}$$

The answer is easily estimated to be about

$$\frac{1}{(0.2 \times 3)} \text{ or } 1.33 \times 10^{-5}$$

- Set the left-hand C scale index over 2 on the D scale.
- Set the hairline over 25 on the C scale.
- Slide the right hand C scale index under the hairline.
- Set the hairline over 5 on the C scale.
- Align the scales.
- Read the answer under the hairline on the CIF scale.

$$X_c = 1.27 \times 10^{-5}$$

Example 3.
$$X_c = \frac{1}{2\pi(8.7 \times 10^6)(150)(10^{-12})}$$

Great care should be used with the power of ten. In this example, change the denominator to read

$$X_c = \frac{1}{(2)(0.87)(0.15)\pi \times 10^{-2}}$$

$$X_c = \frac{10^2}{2(0.87)(0.15)\pi}$$

The approximate answer is $\frac{1}{1.1}$ or about 10^2

- Set the right-hand C scale index over 2 on the D scale.
- Set the hairline over 87 on the C scale.

- Set the left-hand C scale index under the hairline.
- Set the hairline over 15 on the C scale.
- Align all scales.
- Read the answer under the hairline on the CIF scale.

$$X_c = 121$$

EXERCISE 20-2

$$(1). X_c = \frac{1}{2\pi(8)(5)} \quad (3). X_c = \frac{1}{2\pi(400)(0.5)(10^{-6})}$$

$$(2). X_c = \frac{1}{2\pi(60)(0.3)(10^{-6})} \quad (4). X_c = \frac{1}{2\pi(6)(10^3)(8)(10^{-12})}$$

$$(5). X_c = \frac{1}{2\pi(5)(10^6)(2)(10^{-6})}$$

- A capacitor of $20 \mu\text{f}$ offers how much reactive opposition to a current of 60 cps?
- What is the difference in capacitive reactance of a $0.015\text{-}\mu\text{f}$ capacitor to a frequency of 5 kc and 5 Mc, respectively?
- What is the reactance of a $0.05\text{-}\mu\text{f}$ capacitor at 100 cycles; at 1600 kc?
- If the frequency of Problem 6 is doubled and the size of the capacitor is doubled, how much reactance will the circuit offer?
- A series circuit consists of a capacitor of $8 \mu\text{f}$ and a resistor of 1000 ohms. Would the resistance (at 60 cps) of the capacitor be greater or less than the ohmic resistance of the resistor?

APPENDIX A

New Prefixes For Units

The National Bureau of Standards and the International Committee on Weights and Measures have recommended the following for denoting multiples and submultiples of units.

<u>Multiples and Submultiples</u>	<u>Prefixes</u>	<u>Symbols</u>
1,000,000,000,000 = 10^{12}	tera*	T
1,000,000,000 = 10^9	giga*	G
1,000,000 = 10^6	mega	M
1000 = 10^3	kilo	k
100 = 10^2	hecto	h
10 = 10^1	deka	dk
0.1 = 10^{-1}	deci	d
0.01 = 10^{-2}	centi	c
0.001 = 10^{-3}	milli	m
0.000001 = 10^{-6}	micro	μ
0.000000001 = 10^{-9}	nano*	n
0.000000000001 = 10^{-12}	pico*	p

* New term.

APPENDIX B

EXPONENTIALS.

Value of e^n for the values of n shown in the first column and at the top.

n	0.00	0.01	0.02	0.03	0.04	0.05	0.06	0.07	0.08	0.09
0.0	1.000	1.010	1.020	1.030	1.041	1.051	1.062	1.073	1.083	1.094
0.1	1.105	1.116	1.127	1.139	1.150	1.162	1.174	1.185	1.197	1.209
0.2	1.221	1.234	1.246	1.259	1.271	1.284	1.297	1.310	1.323	1.336
0.3	1.350	1.363	1.377	1.391	1.405	1.419	1.433	1.448	1.462	1.477
0.4	1.492	1.507	1.522	1.537	1.553	1.568	1.584	1.600	1.616	1.632
0.5	1.649	1.665	1.682	1.699	1.716	1.733	1.751	1.768	1.786	1.804
0.6	1.822	1.840	1.859	1.878	1.896	1.916	1.935	1.954	1.974	1.994
0.7	2.014	2.034	2.054	2.075	2.096	2.117	2.138	2.160	2.181	2.203
0.8	2.226	2.248	2.270	2.293	2.316	2.340	2.363	2.387	2.411	2.435
0.9	2.460	2.484	2.509	2.535	2.560	2.586	2.612	2.638	2.664	2.691

ANSWERS TO PROBLEMS

Exercise 1-3

(a). 1.2 (c). 2.9 (e). 5.7 (g). 140 (i). 410 (k). 650 (a).
0.012 (f). 0.088 (m). 0.033

Exercise 1-4

(A). 1.08 (B). 3.04 (C). 2.12 (D). 1.63 (E). 1.88

Exercise 2-2

(1). 3.8 (3). 39 (5). 3.6 (7). 9 (9). 5.5 (11). 24

Exercise 2-3

(1). 10.5 (3). 3.46 (5). 12.4 (7). 90 (9). 9.05 (11). 38.18
(13). 16.3 (15). 7.62 (17). 1.92 v and 5.92 v (19). 13.55 v

Exercise 2-4

(1). 3 (3). 4.5 (5). 22 (7). 7 (9). 2.84

Exercise 2-5

(1). 0.42 amp (3). 22.2 v and 96.2 v (5). 92 ohms (7). 37.5 v
and 50 v (9). 0.33 amp (11). 24 ma.

Exercise 3-0

(1). 1.62×10^5 (5). 8.04×10^{-3} (9). 6.204×10
(3). 8.36×10^5 (7). 8.93×10^5

Exercise 4-1

(1). 60.6×10^7 (5). 11.15×10^{-4} (9). 1.67×10^7
(3). 57.1×10^{-6} (7). 34.68×10^{-5}

Exercise 4-2

(1). 0.14×10 (3). 6.77×10^{-2} (5). 0.899 (7). 10^2 (9). 7.4

Exercise 5-1

(1). 1.55 (3). 725 K (5). 118 (7). 1.1 (9). 16.4

Exercise 6-1

(1). 72 w (3). 68.4 mw (5). 120 mw (7). 29.2 mw

Exercise 6-2

(1). 1.22 w (3). 125 mw (5). 5.65 mw

Exercise 7-1

(1). 75 v (3). 1:3.63 (5). 1.43 turns

Exercise 8-1

(1). 166.2 (5). 67×10^{-2} (9). 8.9×10^8
(3). 3.84×10^9 (7). 118.1×10^{15}

Exercise 8-2

(1). 754 ohms (3). 50.24 K (5). 3.88 mw
(7). $Q = 1200$

Exercise 9-1

(1). 8.63 ohms (3). 2.13 (5). 4.62 K
(7). 2260 (9). 127.2

Exercise 9-2

(1). 55 ohms (3). 0.107 (5). 980 ohms
(7). 392 mg (9). 819 K

Exercise 10-1

(1). 0.143 (5). 0.115 (11). 1.182×10^{-3}
(3). 2.94×10^{-3} (7). 3.33 (13). 10^{-3}
(9). 0.319 (15). 2.19 μsec

Exercise 10-2

(1). 1.250 mmhos (5). 20 ohms (7). 8.33 kc
(3). 265 ohms

Exercise 11-1

(1). 2.51 (5). 7.717-10 (9). 4.654-10
(3). 4.75 (7). 6.799-10 (11). 2.539

Exercise 11-2

(1). 7.748-10 (5). 8.456-10 (9). 4.362
(3). 0.526 (7). 2.883

Exercise 11-3

(1). 4.56 db (3). 1.03 db (5). 32 db

Exercise 12-1

- | | | |
|------------|-------------|-------------|
| (1). 33.5° | (7). 7.5° | (13). 84.1° |
| (3). 54.5° | (9). 50.8° | (15). 13.2° |
| (5). 72° | (11). 26.3° | |

Exercise 12-3

- | | | |
|------------|-------------|--------------|
| (1). 0.87 | (9). 6.31 | (17). 0.1122 |
| (3). 0.122 | (11). 2.605 | (19). 0.93 |
| (5). 0.983 | (13). 1.24 | (21). 144.2 |
| (7). 1.47 | (15). 0.152 | (23). 16 |

Exercise 13-2

- | | | |
|------------|-------------|--------------|
| (1). 40.5° | (9). 23.9° | (17). 14.35° |
| (3). 6.85° | (11). 45° | (19). 36.4° |
| (5). 72° | (13). 58.2° | |
| (7). 30° | (15). 26.4° | |

Exercise 13-3

- | | | |
|------------|-------------|-------------|
| (1). 0.656 | (9). 0.1185 | (17). 0.986 |
| (3). 0.853 | (11). 0.707 | (19). 0.139 |
| (5). 0.648 | (13). 0.932 | |
| (7). 0.272 | (15). 1 | |

Exercise 13-4

- | | | |
|------------|----------|--------------|
| (1). 403 | (5). 247 | (7). $R = 0$ |
| (3). 12.8° | | |

Exercise 13-5

- | | | |
|-------------|-------------|--------------|
| (1). 28° | (9). 26.5° | (17). 83.75° |
| (3). 72.25° | (11). 28.8° | (19). 78.5° |
| (5). 50.5° | (13). 78.5° | |
| (7). 39° | (15). 45° | |

Exercise 13-6

- | | | |
|-------------|-------------|-------------|
| (1). 0.714 | (7). 0.394 | (13). 0.965 |
| (3). 0.108 | (9). 0.985 | (15). 0.642 |
| (5). 0.3158 | (11). 0.954 | |

Exercise 13-7-1

- | | | |
|----------|-------------------|--------------|
| (1). 48° | (3). 201 Ω | (5). 17.3 ft |
|----------|-------------------|--------------|

Exercise 13-7-2

- | | sin | cos | tan |
|-------|-------|-------|----------|
| (1). | 0.665 | 0.747 | 0.89 |
| (3). | 0.775 | 0.632 | 1.25 |
| (5). | 1 | 0 | ∞ |
| (7). | 0.523 | 0.852 | 0.613 |
| (9). | 0.193 | 0.982 | 0.1962 |
| (11). | 0.854 | 0.522 | 1.63 |
| (13). | 0.227 | 0.975 | 0.232 |
| (15). | 0.318 | 0.949 | 0.336 |
| (17). | 0.856 | 0.517 | 1.66 |
| (19). | 0.876 | 0.483 | 1.81 |

Exercise 13-7-3

- | | | |
|------------|-------------------------|---------------|
| (1). 74 ft | (5). 45° | (9). 18.93 in |
| (3). 90 in | (7). $676 / 42.4^\circ$ | |

Exercise 14-3

- | | | |
|----------------------------|---------------------------|----------------------|
| (1). $40 + j29.3$ | (7). $11.28 + j64$ | (11). $8.48 - j8.48$ |
| (3). $0.95 + j1.09$ | (9). $0 + j150$ | (13). 22.15 ohms |
| (5). $0.00388 - j0.001035$ | (15). $2480 \mu\text{mf}$ | (17). 38.5 v |

Exercise 14-4

- | | | |
|----------------------|------------------------------|---------------------------|
| (1). $52.9 + j70.25$ | (5). $100 - j100$ | (9). $0.00337 + j0.00496$ |
| (3). $0.77 + j381$ | (7). $761 + j1.52 \text{ K}$ | |

Exercise 15-4

- | | | |
|---------------------------|---------------------------|--------------------------|
| (1). $73 / 54^\circ$ | (5). $2.82 / 73.3^\circ$ | (9). $54.9 / 37.4^\circ$ |
| (3). $0.137 / 57.1^\circ$ | (7). $4.05 / -9.24^\circ$ | (11). 17.6° |

Exercise 16-2

- | | | |
|------------|-----------|-----------|
| (1). 20.09 | (5). 2.84 | (9). 94.6 |
| (3). 4890 | (7). 3.08 | |

Exercise 16-3

- | | | |
|-----------|------------|-----------|
| (1). 1.22 | (5). 2.03 | (9). 1.88 |
| (3). 1.35 | (7). 1.105 | |

Exercise 16-4

- | | | |
|-------------|-------------|------------|
| (1). 1.02 | (5). 1.045 | (9). 1.072 |
| (3). 1.0855 | (7). 1.0957 | |

Exercise 16-6

- (1). 0.135 (5). 0.395 (9). 0.989
 (3). 0.652 (7). 0.328

Exercise 17-1

- (1). $e_c = 22$ v, $e_r = 5.74$ v (7). 25.7 μ coulombs (15). 10.05 v
 (3). $e_c = 12.18$ v, $e_r = 20$ v (11). 1.02 msec (17). 0.8 sec
 (5). E_a , R , C , and t (13) 8.18 μ a (19). 30.3 v

Exercise 18-1

- (1). 12.56 (5). 278 (9). 0.01635
 (3). 377 (7). 3.49

Exercise 18-2

- (1). 6.28 (5). 51.9×10^4 (9). 233.6
 (3). 1358 (7). 28.3

Exercise 18-3

- (1). 226 (7). 636×10^{-5} (13). 0.049 ohms
 (3). 554×10^6 (9). 37.75×10^8 (15). 143.1 kc
 (5). 12090 (11). 1885, 4530, 30200

Exercise 19-2

- (1). 1.72 (5). 1.18 K (9). 4740
 (3). 1.44 (7). 5.15 (11). 68.6

Exercise 20-1

- (1). 0.106 (5). 79.6 (9). 0.159
 (3). 9.1×10^{-4} (7). 3.02×10^{-5}

Exercise 20-2

- (1). 0.00399 (5). 0.0159 (9). 33.25 ohms
 (3). 796 (7). 2.12 K

INDEX

- A and B scales, 27, 39
 Adjacent side, 58
 Admittance, 46
 Arc function, 57

 C and D scales, 1
 CI scale, 43
 CIF scale, 96
 Capacitance-resistance circuits:
 See RC circuits
 Capacitive reactance, 45, 96, 97
 Characteristics of logarithms, 47
 Coefficient of coupling, 31
 Combined operations of C and D
 scales, 23
 Conductance, 45
 Continued products in
 multiplication, 35
 Cosine function, 62
 Coulombs, 88
 Cursor, 1

 DI scale, 43
 Division, 12
 dividend, 12
 divisor, 12
 quotient, 12

 Exponentials, index laws of, 19
 negative, 81

 Factorial, definition of, 36
 Folded scales, 90

 Graduations:
 primary, 1
 secondary, 2
 tertiary, 5

 Hairline, 1
 Hypotenuse, 58

 Impedance, 39, 46, 58
 Index laws of exponents, 19
 Indicator, 1
 Inductance-resistance (R-L)
 circuits, 39
 Inductive reactance, 35, 90, 92

 L scale, 47
 LL0 and LL00 scales, 83
 LL01, LL02, and LL03 scales, 82
 LL1 scale, 81
 LL2 scale, 80
 LL3 scale, 79
 Logarithms:
 characteristics of, 47
 L scale, 47
 log-log scales, 79-83

 Mantissa, 47
 Multiplication, 8
 on folded scales, 94

 Mutual inductance, 31

 Natural base e , 78
 Negative characteristic, 49

 Ohm's law, 8
 Opposite side, 58

 Parallel resistance, 23
 Period of cycle, 43
 Phase angle, 52
 Polar notation, 66
 Polar-to-rectangular
 transformation, 66, 70
 Power, 27, 30
 Power gain, 47
 Powers of ten, 16
 Primary digits, 8
 Pulse-repetition rate, 46

 RC circuits, 41, 86
 Ratio, 94
 Rectangular notation, 66
 Rectangular-to-polar transfor-
 mation, 66
 Rules of exponents, 19

 S scale, 58
 Scales:
 A and B, 27, 39
 C and D, 1
 CI, 43
 CIF, 96
 DI, 43
 folded, 90
 L, 47
 LL0 and LL00, 83
 LL01, LL02, and LL03, 82
 LL1, 81
 LL2, 80
 LL3, 79
 S, 58
 T, 52
 Sine function, 58
 Slide, 1
 Square-root, 30
 Standard form of numbers, 16
 Stator, 1
 Stock, 1

 T scale, 52
 Table of e^n and e^{-n} , 101 ff.
 Tangent function, 52
 Transformer turn ratio, 32

 Vector addition, 73
 division, 72
 Voltage equation, 29

 Watt's law, 27

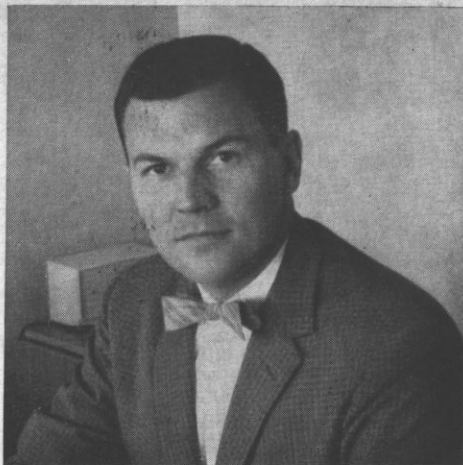

E. Charles Alvarez

Educated at St. Viators Grammar School, E. Charles Alvarez obtained his B.Sc. from San Fernando State College and is currently working to complete his Masters in Engineering.

After service in the U.S. Navy and Merchant Marine, Mr. Alvarez attended a number of schools including the American Television Institute in Chicago, and U.C.L.A.

His industrial background includes work on recording devices for marketing research information for A. C. Nielsen Co., and later Motorola, Inc., where he helped complete a manual for the U.S. Signal Corps on the AN/GRC-10 (a ground communication system).

A position at North American Aviation as an editor in Technical Publications, where Mr. Alvarez worked on the fire control system for the F-100 fighter aircraft, was followed by a teaching position with Pierce College in Woodland Hills, California, where Mr. Alvarez has taught since 1955.

During the summers of each year Mr. Alvarez has kept in touch with the electronic field by work with Hughes Aircraft, Rantec Corporation (in the area of microwaves), Pacific T & T (microwaves), and Atomics International (nuclear reactors).

Mr. Alvarez is a contributor to Industrial Electronic Engineering and is a member of the Institute of Radio Engineers. He also holds a first class FCC radio-telephone license.

Mr. Alvarez is at present an Associate Professor at Pierce College.