



# TYPES AND DETAILS OF BRIDGE CONSTRUCTION

## PART I. ARCH SPANS.

EXAMPLES OF CONSTRUCTED WOODEN, COMBI-  
NATION, WROUGHT IRON AND STEEL ARCHES  
FOR HIGHWAY AND RAILROAD BRIDGES.

A collection of essential features of special and im-  
portant work, illustrating variety of design, develop-  
ment of standard practice and methods of erection.

---

Recorded and Classified for Students, Instructors. Designers,  
Engineers, Architects and Contractors.

---

By FRANK W. SKINNER, M. Am. Soc. C. E.  
Consulting Engineer.  
Associate Editor The Engineering Record.  
Non-Resident Lecturer on Field Engineering at Cornell University.

---

NEW YORK  
McGRAW PUBLISHING COMPANY  
114 LIBERTY STREET  
1904

N. R.

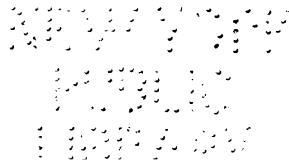

THE NEW YORK  
PUBLIC LIBRARY  
377618  
ACCORDING TO THE  
TITLES OF THE  
R 1907 L

COPYRIGHTED, 1904,  
BY THE  
MCGRAW PUBLISHING COMPANY,  
NEW YORK.

WILEY  
SON  
PUBLISHERS

**To my friend, Axel Sablin, C. E.:**

**In affectionate tribute to his noble  
personality and in recognition of his brilliant  
professional abilities and achievements.**

Vol. 2  
p. 107





# PREFACE.

---

## TYPES AND DETAILS OF BRIDGE CONSTRUCTION.

It is the purpose to present in Types and Details of Bridge Construction the development of advanced practice and its standard details, to illustrate the classes of structures adapted to different conditions, show some of the characteristic differences between American and foreign design and illustrate some primitive or obsolete constructions, besides recording important and well-known examples so as to have their principal data easily accessible. The first consideration in the selection and preparation of data has been in every case to show clearly the special and important features and give only what is essential to the design and present the requirements, conditions and methods involved in the construction and erection of the work. Some explanations have been added to promote clearer appreciation or interesting comparisons. Generally, when structures are essentially duplicates, only one of them is described, and the others are compared with them and their varying or distinguishing characteristics noted. The list of structures described is not complete and the classification is not absolute, but suffice to illustrate different types and show a wide range of practice in details. The bridges have been arranged in order and grouped in classes, and the descriptions are in most cases supplemented by specific references to any more extended articles which have been published about them in technical journals or professional papers, and may be consulted in libraries for additional data in special cases. Some of the most interesting data have been received especially for this book through the kindness and friendship of the engineers associated with the construction of the bridges described. In some cases these data included rare photographs and valuable drawings, and I take pleasure in expressing my thanks for them to Messrs. Theodore Cooper, F. S. Cook, John Stirling Deans, H. W. King, C. F. Loweth, Foster Milliken, C. N. Monsarrat, A. W. Münster, F. C. Osborn and J. A. L. Waddell.

Many of the descriptions had been previously written by the author for "The Engineering Record," and are here reprinted with little or no modification. Others have been rewritten from descriptions in various engineering periodicals or have been illustrated with drawings prepared by reference to their engravings, for which general acknowledgment is here made.

That this book may prove helpful to students and teachers, and of value to engineers, architects, contractors and designers is the hope that inspired its preparation.

Tompkinsville, N. Y., July 1, 1904.

FRANK W. SKINNER.

# CONTENTS

---

INTRODUCTION .....	I
PART I.	
WOOD AND IRON ARCH SPANS .....	3
I. Ancient and Modern European and Asiatic Bridges.....	5
II. Early and Later American Bridges .....	9
PART II.	
SPANDREL BRACED ARCHES .....	18
III. Berlin, Cross River, Cedar Avenue and Noce Bridges. Spans 72 to 197 feet .....	19
IV. Fairmount Park, Menominee and Salmon River Bridges. Spans 200 to 270 feet .....	31
V. The Mirabeau, Panther Hollow, Surprise Creek and Driving Park Bridges. Spans 326 to 416 feet .....	49
VI. The Rio Grande and Lake Street Bridges. Spans 449 and 456 feet .....	66
VII. Niagara and Viaur Bridges. Spans 550 and 721 feet.....	88
PART III	
ARCH TRUSSES .....	109
VIII. The Brunswick, Jefferson, Carlsburg, Riverside Cemetery, Old Forbes Street and Brooklyn-Brighton Bridges. Spans 79 to 168 feet .....	110
IX. Manhattan Avenue, Seine, Passy and Stoney Creek Bridges. Spans 168 to 336 feet .....	122
X. Cornhouse, Paderno and Eads Bridges. Spans 377 to 520 feet	149
XI. Kaiser Wilhelm and Garabit Bridges. Spans 525 and 541 feet .....	162
XII. The Bonn, Duesseldorf, Straubing, Worms, Harburg, Gru- enthal, Levensau and Douro Bridges. Spans 208 to 614 feet.	176
XIII. The Niagara Falls and Clifton Bridge. Span 840 feet.....	187
PART IV.	
PLATE GIRDER ARCHES .....	209
XIV. Severn, Wearmouth, Louvre, Austerlitz, Southwark, Huns- let, Buffalo Park, Victoria Gorge, Berlin, Belle Isle, Riverside Drive and Cornhouse Bridges. Spans 40 to 113 feet .....	210
XV. Forbes Street, Marne, Mill Street, Chagrin River and Fall Creek Bridges. Spans 144 to 170 feet .....	224
XVI. North and Fern Hollow Bridges. Spans 175 and 195 feet.	242
XVII. Midi, Mahoning River and Main Street (Minneapolis) Bridges. Spans 205 to 258 feet .....	260
XVIII. Alexander III. and Washington Bridges. Spans 362 and 510 feet .....	271



# INTRODUCTION.

---

## ARCH BRIDGES.

This volume of Types and Details of Bridge Construction includes only arches designed to carry pedestrian, highway or railroad traffic. It is chiefly a collation of data, reduced to the essence of the designs, of comprehensive selections from the classes of structures under consideration. It is confined absolutely to facts about work which has actually been built, without theory or speculation, contains no descriptions of what was proposed or designed on paper merely, and has very little of mathematical or analytical data. It presents condensed descriptions of general and special design, details and construction classified, arranged and cross-indexed for convenient use. The data have originally been prepared from official drawings, photographs and specifications; personal study and notes of important structures, extended reference to principal periodicals and professional papers and reports, and from considerable private data not generally accessible. They have been carefully selected, condensed and simplified; the most important features have been, in many cases, emphasized by special illustrations, and unnecessary or confusing data have been eliminated. Single interesting features have been sometimes picked out of obscure descriptions of otherwise commonplace designs where they would not be likely to be noticed or understood without unusual pains. This volume is intended to be sufficiently complete for arch bridges of wood, iron, and steel, and to include the special features and general character in each case, and present altogether all the features found in advanced and ordinary construction. It is intended as an epitome of practice in America, and as a concise summary sufficient for ordinary purposes of record and reference and for practical use for design, study and comparison by the engineer, architect, contractor, draftsman, designer, instructor, student and municipal official.

General plans, sections or elevations are given only where necessary to a clear description, and are accompanied by such details as are novel or characteristic, without regard to merit. Good and bad examples are shown, some that are curiosities, some which would be inexcusable in current practice, and some which were permissible when designed, but have been superseded because of improved facilities of manufacture and advance in practice. As far as data have been available the selections have been intended to illustrate the developments and wide variations in actual construction, and serve simply as records and for suggestions of characteristics to be copied, modified or avoided.

Where scale drawings were not available, sketches have been made to show arrangement and details regardless of exact dimensions. Many interesting and important examples are not included, but the descriptions include, as far as the data was readily available, most of the typical and remarkable features of design, and some eccentricities in American practice, and a few cases in European practice which are notable, important, curious or of practical value, except those which are of such simplicity and standard use as to be universally familiar to those interested in the subject.

Where no references are given the data has been secured from personal notes, official blue prints or from abstracts of reliable data in private libraries. In all drawings unnecessary detail has been eliminated, and the greatest simplicity has been attempted; in some cases the scale and proportions have been modified to emphasize specific features; sometimes relative thickness and clearances have been magnified and rivet spacing assumed or the distinction between shop and field driven rivets neglected unless essential to the points involved. Figured dimensions are accurate, and generally the leading proportions are reliable, even if only sketched; but the drawings are never intended for working drawings, being used solely to show the arrangement and relation of different parts, and the special features of details and connections.

## PART I.

### WOOD AND IRON ARCH SPANS.

Wood and iron arch spans are wholly of wood, wholly of iron or of wood and iron combined, being called in the latter case simply combination arches. The iron may be either cast or wrought iron, or a combination of both. The types are usually single solid ribs or parallel chords with web members, although some examples, especially among the early long-span bridges in America, have divergent top and bottom chords or are practically spandrel braced, and some have a single arch rib to reinforce a complete square truss. These are often found in the Towne wooden lattice trusses, and are not here considered. Some arch ribs have their ends connected by horizontal members, which do not take up any considerable amount of the thrust, and may, notwithstanding, be considered as arches, when, if the full horizontal reaction is taken by a horizontal lower chord they become bowstring trusses.

The earliest examples of arch spans were, of course, built wholly of timber and wood, and iron has been a comparatively recent addition, chiefly applied to arch trusses with parallel chords and radial, screw-ended wrought iron tension rods, dividing the truss in panels X-braced with timber diagonals, like Howe trusses with curved chords. There is little data conveniently available of arch trusses with cast iron compression members and wrought iron tension members, and such a combination is now, of course, obsolete. The earliest iron bridges of any kind were doubtless cast iron arch ribs, with more or less separate spandrel members. Later, cast iron arches have carefully designed plate girder rib sections, well proportioned as true voussoirs. During the short time that wrought iron was used for general structural purposes it was applied to both arch ribs and arch trusses, but these correspond essentially to the steel structures which have entirely superseded them, and which have been developed to a high degree in both riveted and pin-connected forms, which are fully considered in succeeding parts of this book. Only the permanent structures designed to sustain traffic are considered here, various



types which have been used for temporary purposes, as falsework for roofs, and as centering for long span masonry arches, although many times true arches **are not included in the scope** of the present volume.

## CHAPTER I.

### ANCIENT AND MODERN EUROPEAN AND ASIATIC BRIDGES.

The earliest bridge on record is one erected 104 A. D. across the Danube river by the Roman Emperor Trajan, and described in "The Engineering Record," September 19, 1891, and February 20, 1892. Dion Cassius says that it had 170-foot timber arches supported on twenty stone piers 60 feet square and 150 feet high, dimensions which do not seem credible for that date. "The Engineering Record" of February 20, 1892, mentions a 390-foot span built over the Limmat, in the middle of the eighth century and believed to have been a combination of timber arches and trusses. In 1809 the Bamberg bridge over the Regnitz was erected with an arch of 206 feet span and only 16 1-2 feet rise. Its ribs were built up of several thicknesses of planks; a detail of construction common in Europe in the beginning of the nineteenth century.

A highway bridge near Kandy, Ceylon, which was described in "The Engineering Record" of December 2, 1893, has a 205-foot span, with a 20-foot roadway carried on four wooden arch ribs of about 20 feet rise. Each rib is composed of three double beams about 2 feet apart in the clear, in the same vertical plane. Each half of a double beam is composed of two 12-inch timbers from 14 to 18 inches deep, keyed together side by side. The three beams of each rib are keyed together with dovetailed pieces 8 feet apart, and in the centers of the panels thus formed there are radial iron rods extending up to the level roadway platform, with bearing nuts on the upper and lower sides of the ribs. The ribs are connected by transverse X-bracing in radial planes and the roadway is carried by pairs of radial posts on each side of each rib at panel points.

The Mori river, near the east coast of the Province of Suwo, Japan, is crossed by a five-span wooden arch highway bridge called, the Kintai-Kyo, which means "The Bridge Over the Girdle with Interwoven Flowers." This description of it is reprinted from "The Engineering Record" of February 8, 1902:

The structure is stated to have been built in 1673 from the

plans of the daimio of that time. The span of each of the central three openings is 149 feet, while that of the side openings is somewhat less. The total length of the structure is 745 feet, and the greatest height above low water at the crown of any span is  $71\frac{1}{2}$  feet. The roadway is nearly 18 feet wide.

The piers are built of rough rubble masonry, and in many places, particularly in the coping, there are metal clamps to bind the blocks together. The piers are about 37 feet high. The middle piers are carried down about 30 feet below the surface to bed-rock, and special precautions have been taken to prevent erosion about them.

The superstructure is mainly composed of five arch ribs of keaki wood, particularly prized in Japan for its strength, while the covering and the balustrades are of hinoki wood, a species of cypress which is specially fitted to withstand the influence of the weather. The solid arch ribs are made of beams placed one over the other and bolted together, the number of beams decreasing toward the center. In addition to the bolts the timbers are tied together by a zigzag lattice of planks nailed to the sides of the ribs. The beams are quite

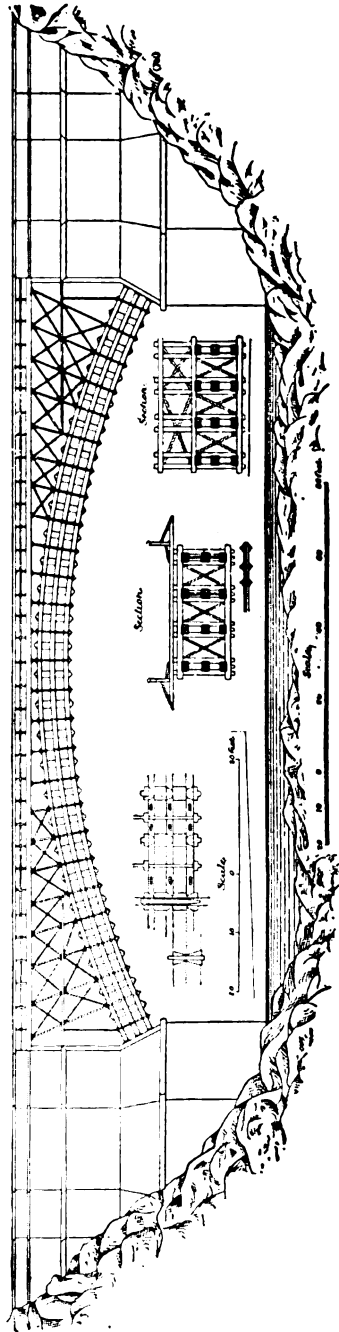

HIGHWAY BRIDGE NEAR KANDAV, CEYLON, 206-FOOT SPAN.

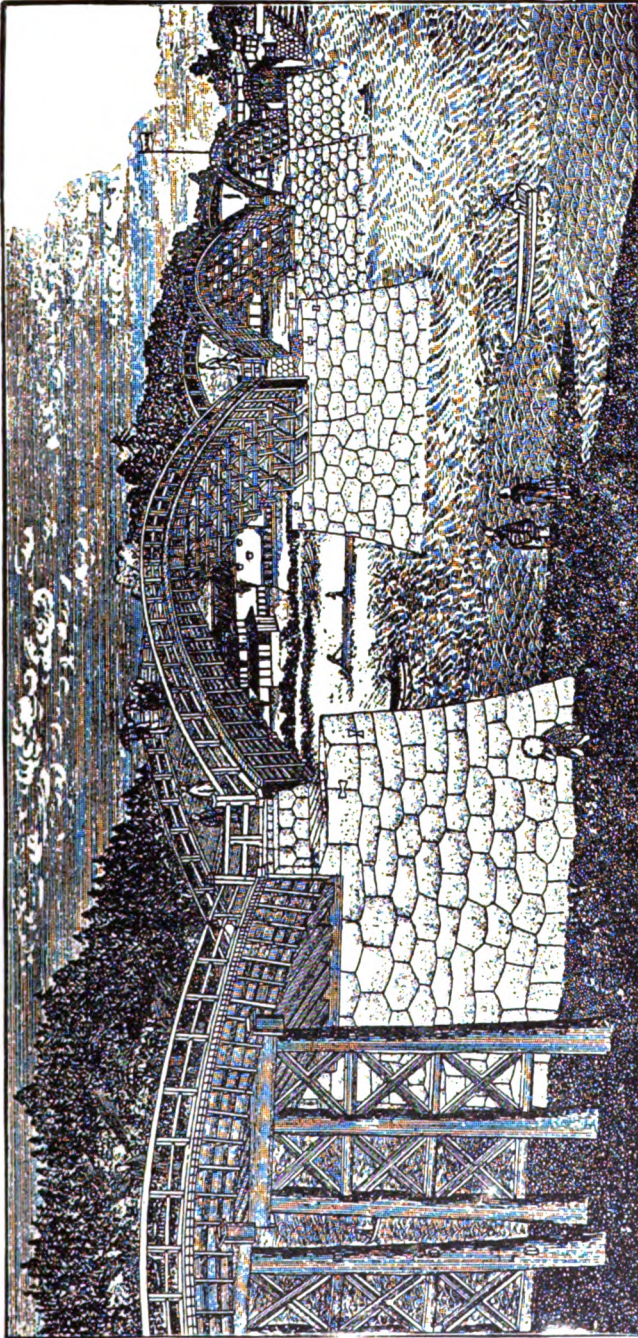

KINTAI-KYO BRIDGE, BUILT IN 1673, WITH FIVE SPANS OF NEARLY 150 FEET EACH.

short and are carefully fitted together, and to protect the abuttings from moisture the joints are covered with sheets of copper. The exposed surfaces of the outside ribs and the projecting ends of the cross timbers are carefully boarded over. The ribs are connected by cross timbers and X-bracing, arranged in planes coinciding with the radial lines of the arch.

In feudal times it was the practice to renew one of the spans every five years, like some of the temples, so that the entire bridge was rebuilt every quarter century. Since the maintenance of the structure was assumed by the city, the repairs and renewals occur only as they are needed. The posts of the falsework required for the purpose in the two end spans are left in place, making these spans appear from the distance to be a kind of hump-backed trestlework. The falsework for the other spans cannot be left in place, for it would be carried away by the floods, which are sudden and high.

A particularly interesting feature of the bridge is the roadway. It is manifest from the engraving that the profile of the spans prevents their use by animals and carts. For the pedestrians, to whom the structure is thus restricted, the roadway is formed into a series of steps, with uniform treads and variable rises. The crossing of the bridge, owing to this repeated rising and falling system of stairs, is fatiguing, and the uncomfortable form of the steps adds to the labor. Fortunately, ice rarely forms in the locality of the structure, or the steps would be almost impassable. Water that falls on the roadway is drained toward the piers by a suitable inclination of the planks.

## CHAPTER II.

### EARLY AND LATER AMERICAN BRIDGES.

In a valuable paper on American Railroad Bridges, published in the "Transactions" of the American Society Civil Engineers for July, 1899, Mr. Theodore Cooper, C. E., traces the history and development of long span bridges in this country and describes wooden arches at Easton, Waterford, Philadelphia, and Trenton. Three 163-foot spans were built across the Delaware river at Easton, Pa., in 1805, and remained in use for about ninety years. Each span had two trusses about 27 feet apart in the clear, 20 feet deep over all in the middle and 34 feet deep at the ends. The centers of the floor beams were supported by an inter-

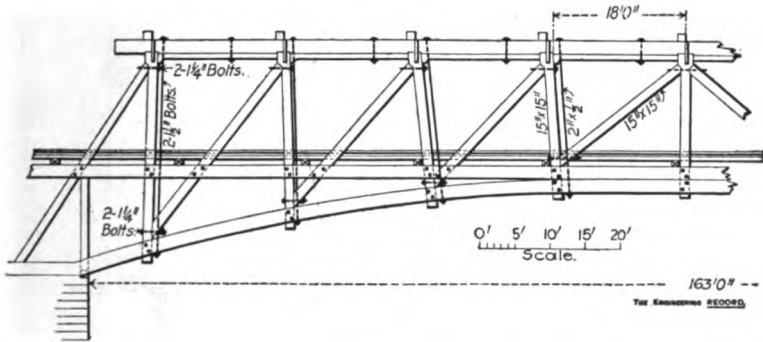

EASTON BRIDGE.

mediate arch rib like the lower parts of the side trusses. The bottom chords were made of two 15x18-inch timbers bolted together through the ends of the vertical posts, which acted as keys. The two end panels were reinforced by pairs of 9x18-inch side pieces. The 15x18-inch top chord was reinforced by an 8x15-inch thrust piece bolted to the under side between the vertical posts. The tops of the inclined posts were secured by 1 1/4-inch bolts with keys instead of nuts. The floor beams were single 12x13-inch timbers carried on pairs of 15x18-inch stringers bolted across the vertical posts, which were dapped over them and the bottom chord timbers. The trusses were connected by upper transverse

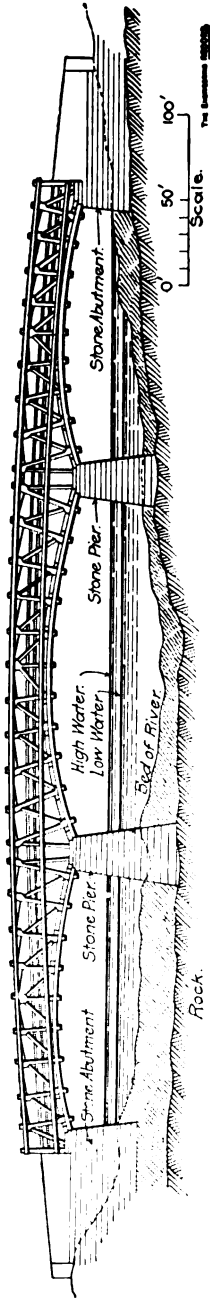

SCHUYLKILL PERMANENT BRIDGE.

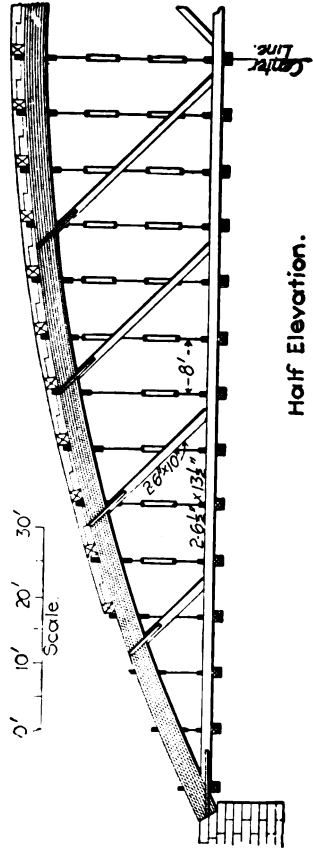

Half Elevation.

ORIGINAL TRENTON BRIDGE OVER THE DELAWARE RIVER.

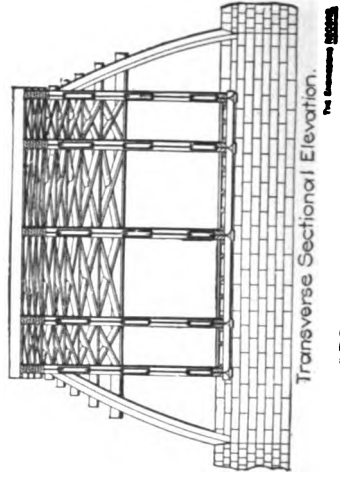

Transverse Sectional Elevation.

ORIGINAL STRUCTURE.

struts, with solid knee-braces, and were always protected by a double pitched roof. After nearly ninety years' service, five-sixths of the original timber was still good and sound.

The Waterford bridge over the Hudson river was built in 1804, and was still in use and in good condition in 1890. It has four spans with clear lengths of 154, 161, 176 and 180 feet, with three lines of simple rectangular trusses about 15 feet deep over all, and 17 feet apart on centers. There were vertical posts about 12 feet apart and intersecting diagonals in every panel. Each truss was reinforced by an arch rib consisting of two 8x16-inch timbers bolted on opposite sides. They had 20 feet rise, were tangent to the top chords at mid-span, and were seated at the ends on skewback pieces bolted to the extended lower parts of the vertical end posts, which were carried down on the faces of the piers.

The Colossus bridge over the Schuylkill river, at Fairmount,

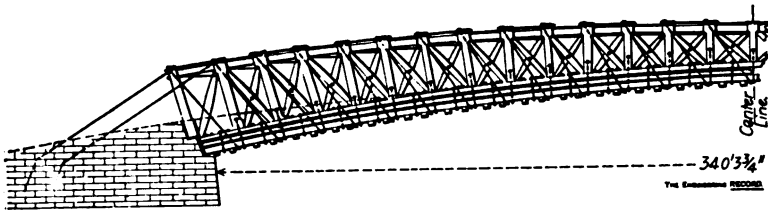

COLOSSUS BRIDGE.

Philadelphia, was built in 1812, and destroyed by fire in 1838. It had a span of about 340 feet, and rise of about 20 feet. The trusses had top and bottom chords curved at different radii, and were about 20 feet deep in the middle, and 30 feet deep at the ends. They were divided by radial posts into panels about 16 feet long, with wooden X-braces and iron diagonal main ties in each. The bottom chords were made of three tiers of timbers keyed together, the ends of the top chords were anchored by inclined tension rods to the abutment masonry, and both top and bottom chords were connected by transverse horizontal struts.

The Schuylkill Permanent Bridge at Philadelphia was finished in 1806, and had two spans of 150 feet, and one of 195 feet clear. There were three lines of arch trusses about 20 feet apart, with a rise of about 20 feet in the bottom chord and about 10 feet in the top chord from abutment to center of middle span. The trusses were about 20 feet deep in the middle, and about 35 feet



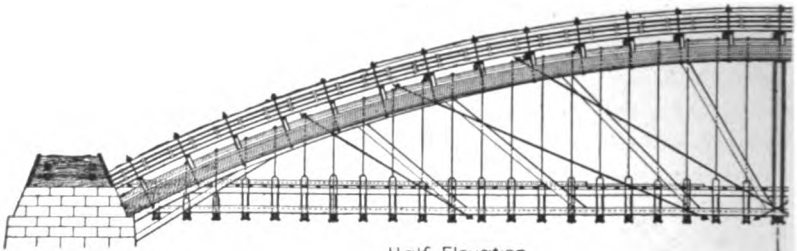

Half Elevation.

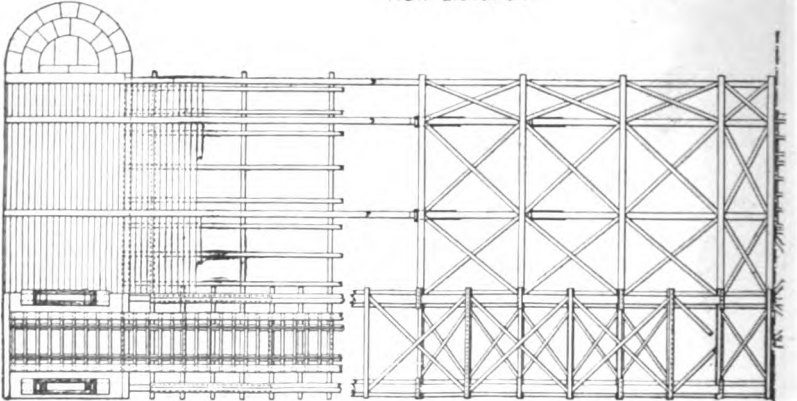

Half Plan.

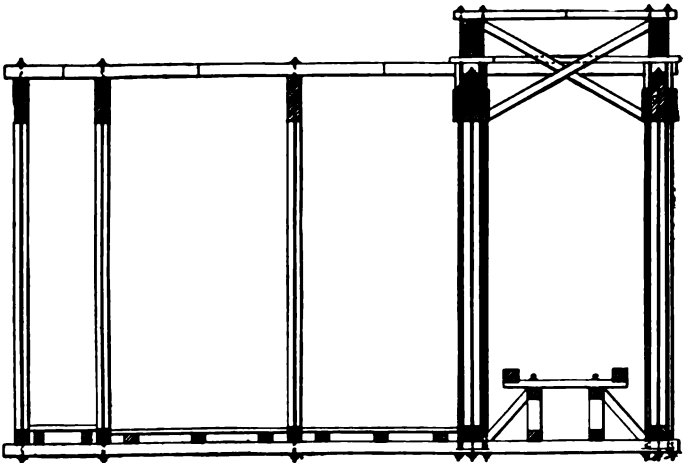

Cross-Section at Center  
TRENTON BRIDGE REINFORCED AND ENLARGED.

deep at the piers. The bottom chords had skewback seats on both sides of the piers, above which the top chords were continuous. The roadway was "through" parallel to the top chord and cambered in a continuous curve from abutment to abutment. The bridge was roofed and had transverse top chord struts and sway bracing under the floor at the piers.

The highway bridge over the Delaware river, at Trenton, had four-arch spans of 161, 186, 198 and 203 feet, clear. It was finished in 1806, and removed in 1875. There were in each span five arch ribs with bottom chords and counter brace diagonals. Each rib was 32 inches deep, built up of 4-inch planks laid flat and breaking joints. The ribs had rise of about 30 feet and were connected in the middle by X-bracing, which extended as near the ends as there was clearance for traffic. The floor was suspended from the ribs by iron verticals 16 feet apart for the outside and 8 feet apart for the inside ribs. The ends of the spans were braced laterally by semi-arch ribs 50 feet long splayed out each side to a width of about 50 feet on the abutments. In 1848 one line of trusses was reinforced and another line was added to help carry a railroad track.

Mr. Cooper also describes several other long-span arch bridges built in early times. The Deer Island bridge across the Merrimac river had a 160-foot arch span built in 1792. The Piscataqua bridge, near Portsmouth, N. H., was built in 1794, and had a 244½-foot arch span, with a rise of 27½ feet and three trusses 18½ feet deep. It was 38 feet wide and the chords were made of two timbers each, selected from crooked pieces corresponding to the curve. The butt joints were staggered and the chord pieces were connected by dovetailed keys. A similar 236-foot span was built in 1796 across the Connecticut river, at Hanover, N. H., and fell of its own weight in 1804. White pine timbers 18 inches square and 60 feet long were used in its construction.

A highway bridge over the Mendota ravine, near St. Paul, Minn., has a 192-foot arch span about 95 feet in extreme height. There are two hingeless Howe truss arch trusses about 15 feet deep and 18 feet apart on centers with about 48 feet rise. The chords are spliced with wooden fish-plates in vertical planes, and have cast-iron angle blocks for the bearings of the web members. The lower chords are reinforced by horizontal adjustable tension rods connected to them about one-third the distance from the crown to the skewback. The floor beams are carried on vertical

spandrel posts from 9 to 11 feet apart, which are seated on the top chords at panel points and are X-braced transversely but not longitudinally.

The lower chords have square ends seated on cast iron skew-back pedestals which receive the end vertical posts. The latter continue beyond the top chords to form spandrel posts, and are bolted between the top chord timbers, which have no end bearings. Adjacent and parallel to nearly all the radial members of the trusses are sway brace frames composed of T-shaped horizontal top and bottom chord transverse struts and 3x10-inch intersecting diagonal planks bolted to the radial web pieces of the struts. On both sides of the top chords and on the under side of the bottom

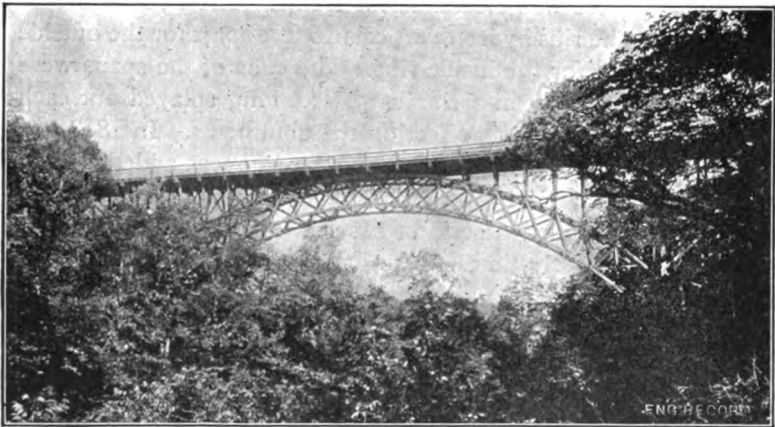

MENDOTA HIGHWAY BRIDGE, ST. PAUL, 192-FOOT SPAN.

chord 3x10-inch lateral X-bracing is bolted between the transverse struts. Bevelled filler pieces are bolted on the top chords at panel points, and on them are seated 10x10-inch transverse beams, which form sills for the spandrel post bents.

The Cascade Glen Arch of the Delaware division of the New York and Erie Railroad was built in 1848, and is an excellent example of an all-timber framed arch truss of long span. It has two hingeless arch trusses of 275 feet span, 12 feet deep and 11 feet 9 inches apart on centers. The center truss is double, made up of two duplicates of the side trusses bolted together with filler pieces, and having a width of about  $4\frac{1}{2}$  feet over all. The chords have a rise of 45 feet, and are segments of circular arcs of 232.57 feet radius. The trusses are divided into forty-

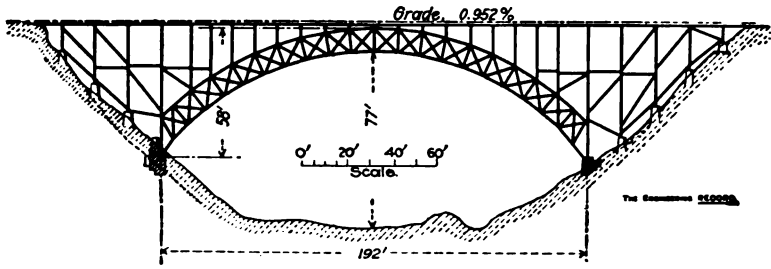

MENDOTA WOODEN ARCH.

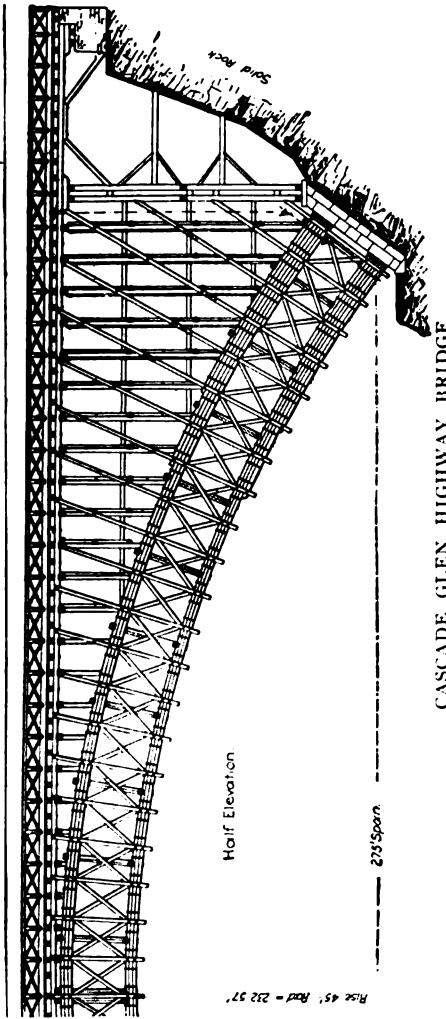

CASCADE GLEN HIGHWAY BRIDGE.

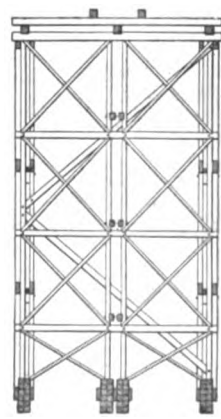
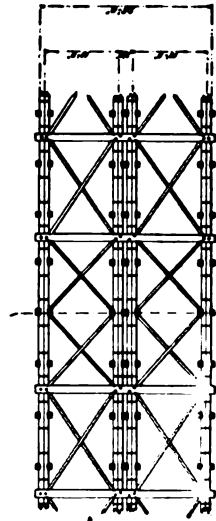

three 6.4-foot panels by pairs of radial timbers bolted across the sides of the chords and extending to the level of the crown to serve as diagonal braces for the spandrel posts. The spandrel posts are single vertical timbers with beveled feet seated 5.5 feet apart horizontally on the top chords, and X-braced transversely.

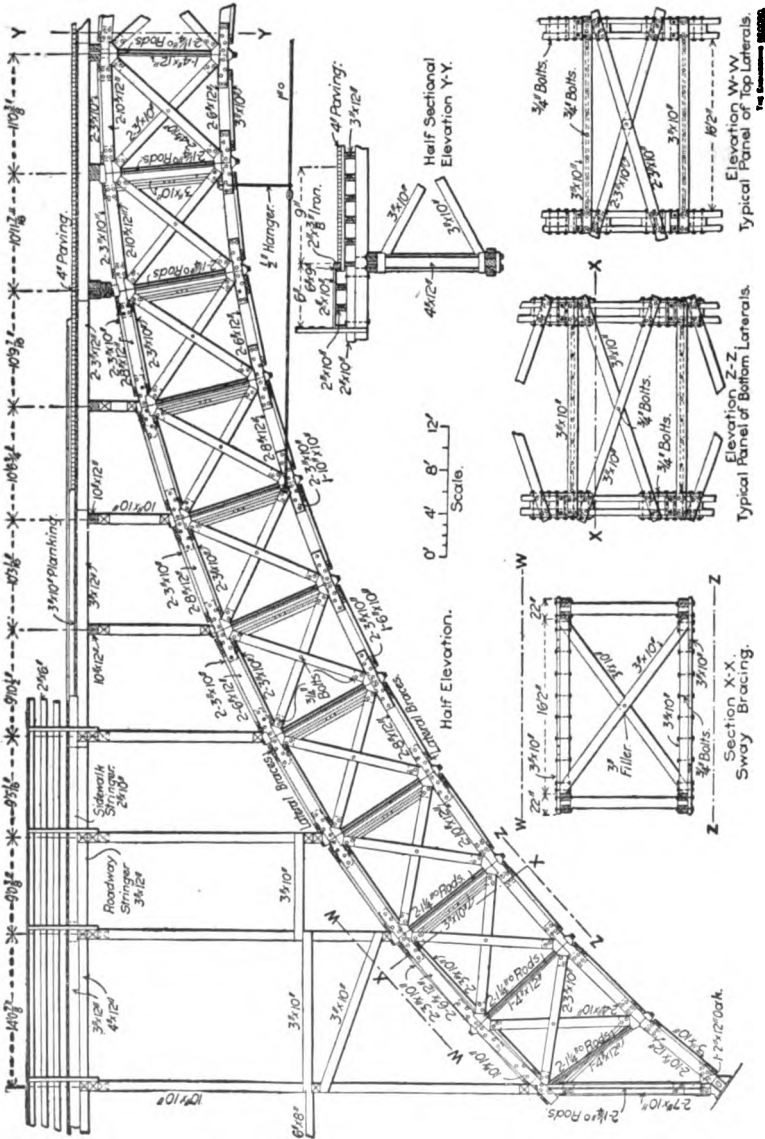

DETAILS OF MENDOTA BRIDGE.

The truss panels have timber X-braces between the radial members, and in the center of every alternate panel there are horizontal transverse struts bolted to the upper sides of the top and bottom chords and X-braced to form sway systems. The sway brace frames are not symmetrical with the spandrel braces, and the panels between them are X-braced in the planes of the top and bottom chords. The spandrel posts have transverse caps supporting three lines of longitudinal girders on the post centers. These carry floorbeams about 2 feet 9 inches apart, and on them there are two main lines of heavy stringers for the track, and seven lines of lighter ones to support the curved deck, 24 feet wide between trusses, hand rails, and about 32 feet wide

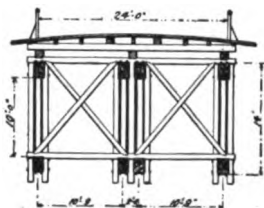

Cross Section at Crown.

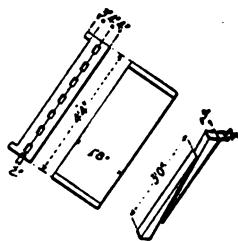

Skewback Adjustment.

over all, so as to have cantilever projections protecting the outside trusses.

The chords are built up of square timbers curved vertically and bolted together with butt joints. They are three deep at the crown and six deep at the skewbacks, and are made of two pieces side by side throughout, making a maximum section of twelve pieces at the skewback. The dimensions of the timbers are not given, but they are apparently of a uniform size of 8 x 8 inches, except perhaps some of the diagonals and secondary braces. The skewback shoes are pairs of thin cast iron flanged plates having on their adjacent faces seven horizontal transverse grooves, 3 inches wide and 1 inch deep in each plate, to receive pairs of folding adjustment wedges. They are seated on the dressed surfaces of large stones in the top courses of shallow piers, normal to the chords, and having foundations excavated to sound rock a short distance below the surface at an angle of approximately 45 degrees with the horizontal.

## PART II.

### SPANDREL BRACED ARCHES.

In Spandrel braced arches the top chords are nearly or quite horizontal, and conform to the usual top chords of ordinary truss spans. The bottom chords are the principal members and are curved to give the arch effect and transmit oblique stresses to the skewback piers. They are usually straight sections for panel lengths and form chords of circular or parabolic arcs. The web members correspond to those of ordinary trusses, are usually vertical and diagonal, and may have either riveted or pin connections. This type is generally three-hinged, but may be hingeless or two-hinged, is usually selected in this country for heavy loads, and is almost or quite invariably a deck structure. Fewer members are required than in arch trusses, as the spandrel posts are also utilized as principal truss verticals, and good opportunities are afforded for lateral and sway brace systems.

They can be easily erected either on falsework or by the guyed cantilever method, or with short anchor arms, and with simple overhead overhanging travelers. They necessitate a great depth of truss for long spans and require approaches at least as high above skewback level as the arch rise. Their appearance is not pleasing adjacent to ordinary truss spans, or girder viaducts, but is better in groups of similar spans or for single spans between high perpendicular banks close to the skewbacks. The same form of truss is adapted to either two or three hinges, and the crown hinge may either be in the bottom chord or the chords may intersect at the crown so that the pin there engages both members.

## CHAPTER III.

### **BERLIN, CROSS RIVER, CEDAR AVENUE AND NOCE BRIDGES. SPANS 72 TO 197 FEET.**

A skew street bridge in Berlin is about 64 feet wide over all, and has three two-hinge spandrel braced arch spans about 72 feet long, and of about 31 feet rise on centers. It has five trusses spaced 6.6 feet apart, which carry on their horizontal top chords a solid buckle plate floor for the roadway, and flat concrete slabs for the two sidewalks. The trusses are braced together with horizontal transverse angles at lower chord level, and flat X-brace bars in the planes of the end four vertical posts, and have a lateral system of flat X-brace bars in the plane of the bottom chords. The semi-trusses have solid webs in the two panels nearest the crown, and both webs and flanges of the chords are spliced. Curious right-angled castings are bolted to the ends of the lower chord flanges and engage rectangular wedges, which serve as skewback hinges and adjustments, and connect them to the pedestal castings with horizontal and inclined beds in the pier masonry. The panels of the outside trusses are filled with ornamental cast iron work, the piers are relieved with mouldings and surmounted by large ornamental cluster lamps, and the roadway is protected by a massive enriched hand-rail, altogether relieving the effect of the construction.

Among the bridges built by the Aqueduct Commissioners of the City of New York to carry the highways over the waters impounded by the new Croton dam, there are two similar spandrel braced two-hinge arch spans. The Kisco bridge has a clear span of 74 feet, and is similar to the duplicate Cross river, Muscoot and Upper Plum Brook bridges of 100 feet clear span and 104 feet 3 inches span and 9 feet 8 inches rise on centers. The 20-foot roadway is carried on two trusses 18 feet apart on centers which have solid webs at the crown and vertical and single diagonal web members at the haunches. The T-shape top chords are made with two angles back to back, having their webs reinforced with vertical plates between the haunches. The bottom chords have cruciform cross sections made with two pairs of angles



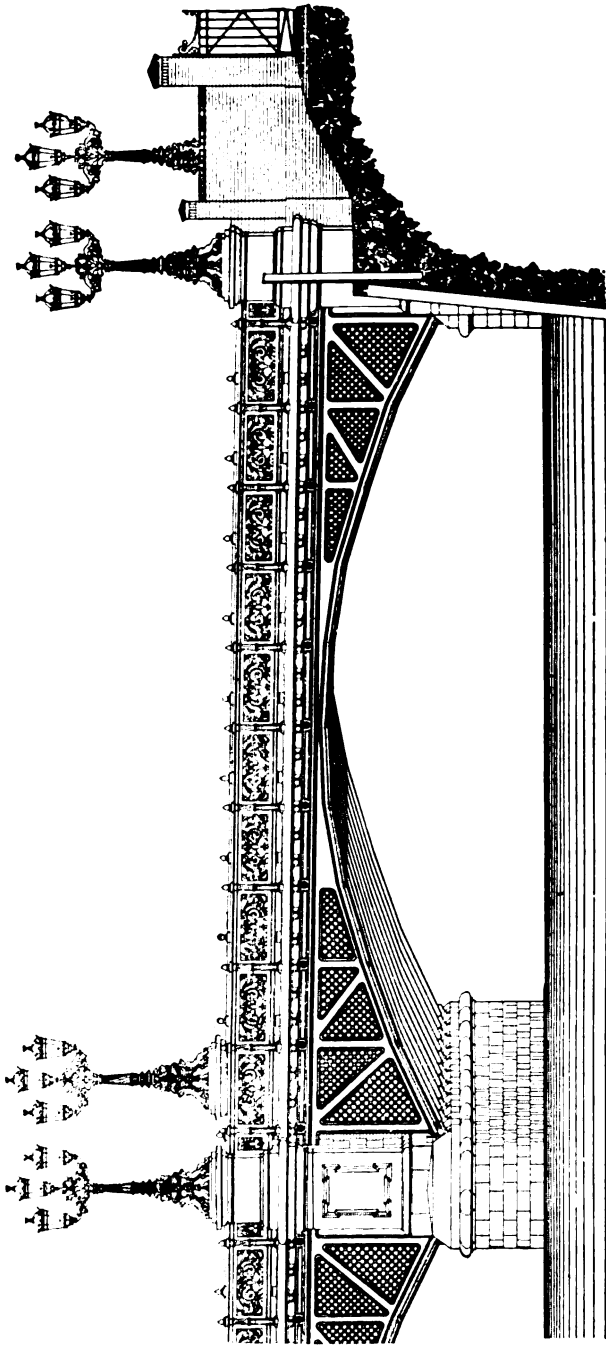

SKEW CITY BRIDGE, BERLIN, SPANS  $69\frac{1}{2}$  FEET.

riveted together back to back with vertical connection plates, riveted between them at panel points.

The web plate and flange angles are spliced at the crown with double cover plates, and the ends of the lower chords have horizontal and inclined flange angles riveted to the web connec-

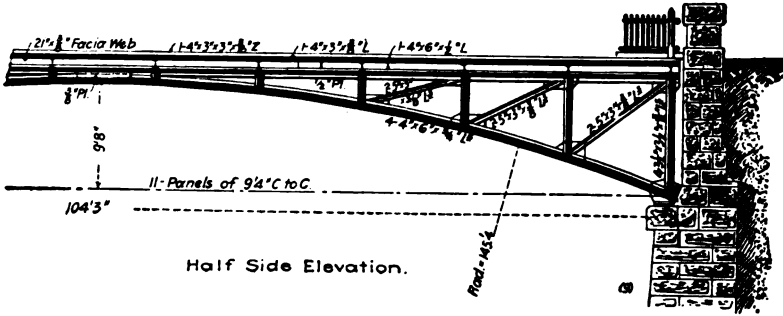

Half Side Elevation.

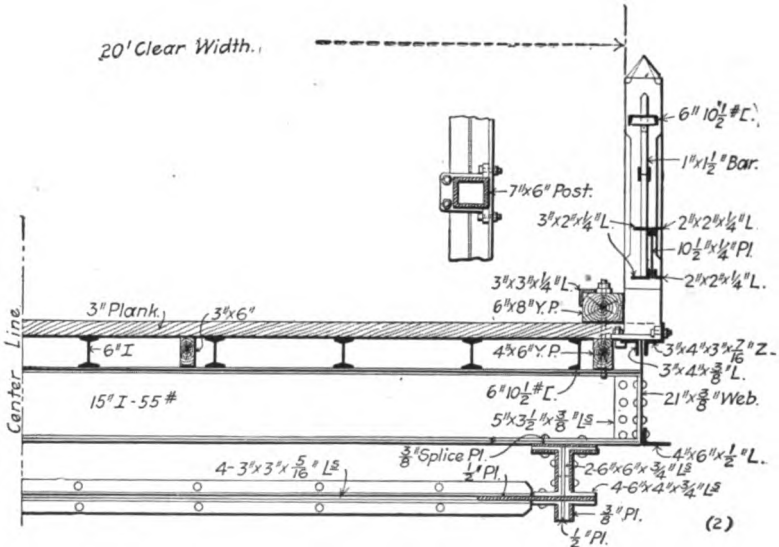

Half Section of Floor.

CROSS RIVER, MUSCOOT AND UPPER PLUM BROOK BRIDGES, NEW YORK.

tion plates. The horizontal flanges take bearing directly on the abutment masonry, and the inclined ones bear on three lines of fillers 4 inches wide, with concrete filling in the spaces between them. The trusses are connected by horizontal struts made with two pairs of angles back to back at lower chord panel points and with T-shape struts made of two angles at alternate top chord



panel points beyond the ends of the solid web. The top and bottom chords are stiffened by X-braces of single angles extending across two panels and riveted to the horizontal plates on the chord flanges. The 15-inch floorbeams rest across the top

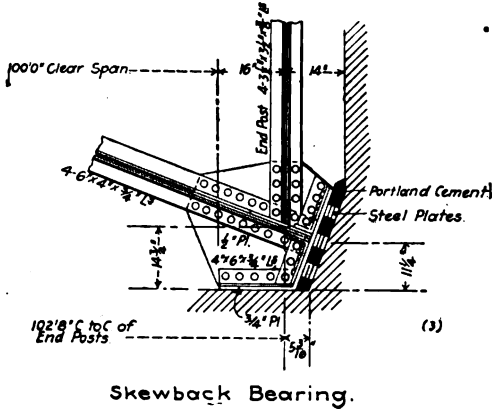

chords and cantilever 12 inches beyond them to carry the fascia girders and cast iron sockets for the hand rail posts.

The Cedar Avenue bridge, Druid Hill Park, Baltimore, Md., has a 150-foot span with three spandrel-braced arch trusses 12 feet apart on centers. They have 10-inch crown and skewback hinge pins, a rise of 38 feet on centers, depth of  $3\frac{1}{4}$  feet at the crown and



DRUID HILL PARK BRIDGE, 150-FOOT SPAN, CEDAR AVENUE,  
BALTIMORE.

39½ feet at the ends, the crown pins being set above the centers of the ends of the semi-trusses. The trusses are braced together by floor-beams resting across the horizontal top chords, by top and bottom lateral struts and diagonals in the planes of both chords, and by diagonal rods in the transverse vertical planes of the verti-

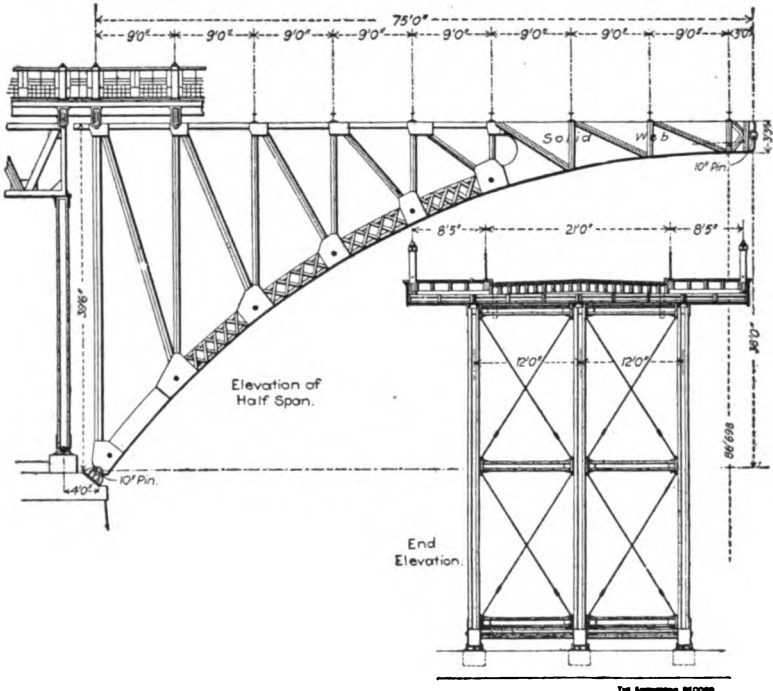

DRUID HILL PARK BRIDGE, CEDAR AVENUE, BALTIMORE.

cal posts. There are no intermediate horizontal transverse struts except between the end posts, and each panel between trusses is X-braced so as to make virtually triple intersection systems of top and bottom laterals.

The truss panels are uniformly 9 feet long, and the vertical and diagonal members have I-shaped cross sections made with two pairs of angles latticed and field-riveted at the ends between tie plates which project beyond the flanges of the chords to make jaws and receive the angles for the field-riveted connections of the transverse struts. These are in vertical planes at the top chord and in radial planes at the bottom chord. For three panels each side of the center the top and bottom chords are united by wide side plates to make a single box section with regular vertical

and diagonal members riveted on the outside of it. All chord splices are riveted and the 2½-inch pins at the six lower chord panel points at each end serve only to receive pairs of single wing plates for the lower lateral rods. The lower chords are made with pairs of channels with horizontal webs, the end panel having solid

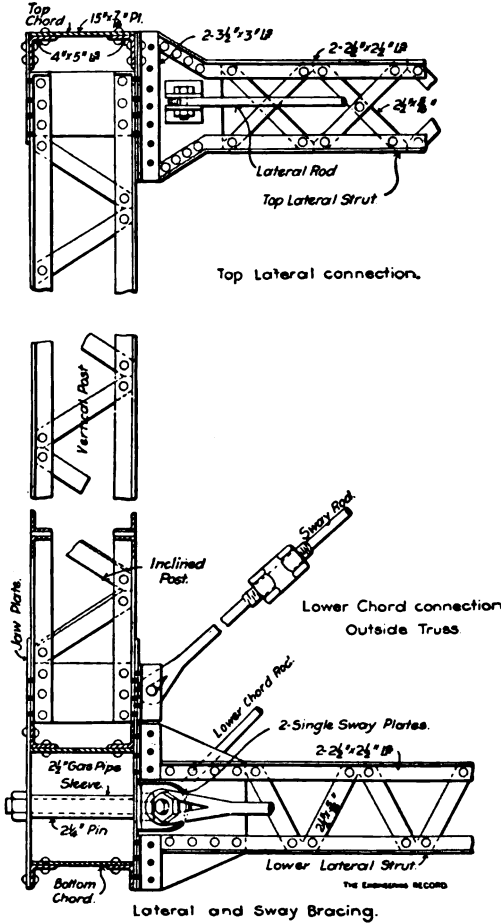

cover plates in vertical planes, and the next four panels on each side having latticed sides.

The skewback pins engage half holes in the ends of the chords and in the webs of the cast-iron pedestals, which have seats normal to the pressure cut in more than a foot from the vertical faces of the bed stones. At the crown the ends of the semi-trusses have a center vertical web, and are reinforced by con-

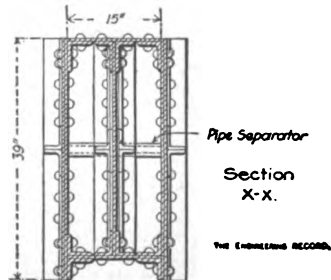
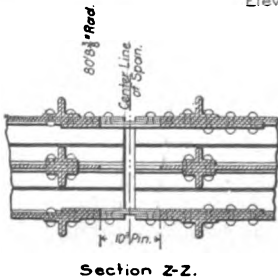
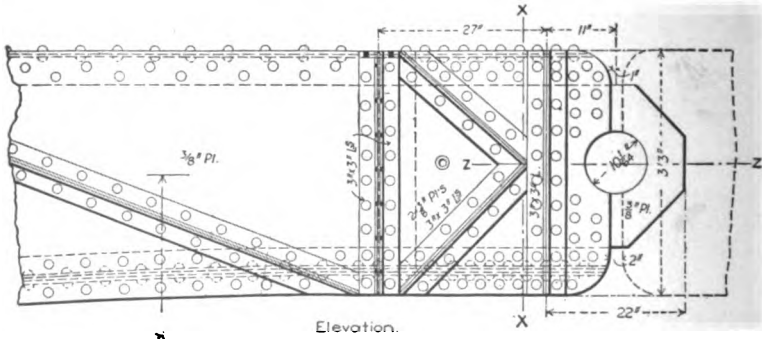
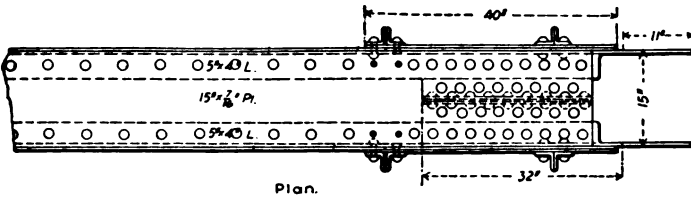
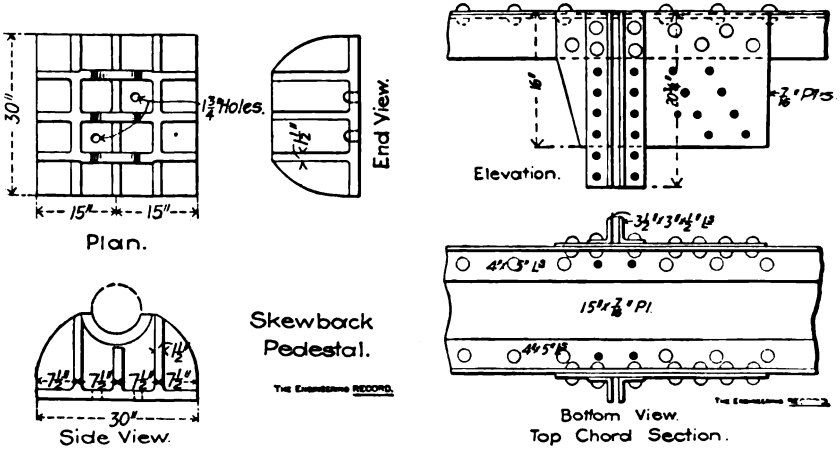

Grown Hinge connection.

verging diagonals which concentrate the pressure on the hinge, the latter being locked by pairs of jaw plates with full holes. The main bearings are half holes, and there is 1-inch clearance between the vertical ends of the trusses. The hinge pins have 3-inch holes through the axes, and those at the skewbacks have no nuts, but are locked in place by collars turned out of the solid at each end. The crown-pin has one solid collar and one loose collar secured by four setscrews. The lower chord panels are not chords of circular arcs, but are bent to true curves, with radii of

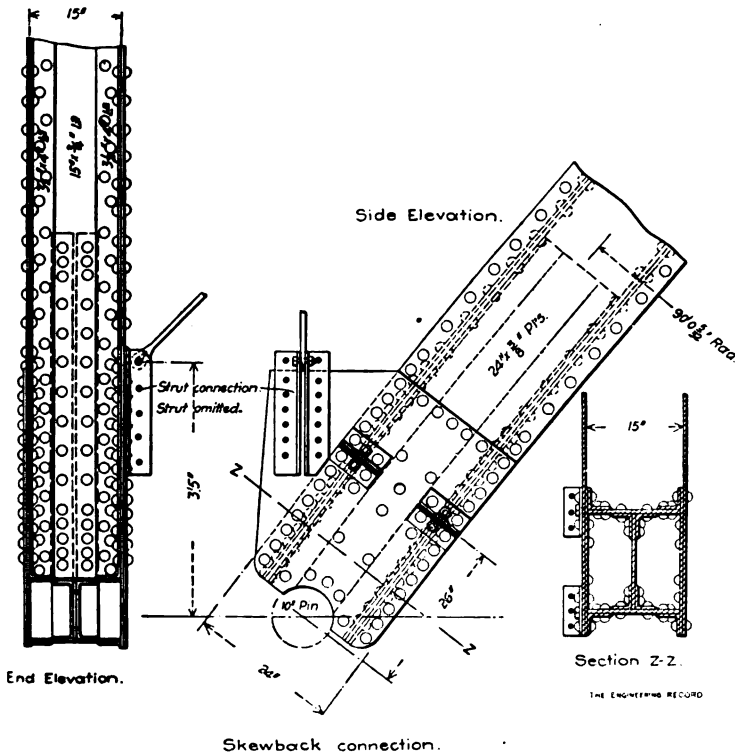

about 93 feet for the three end panels, and about 87 feet for the remaining 11 panels. The end sections of the top chord are shallow, inverted troughs, made with two angles and a top cover plate with wide, vertical connection plates riveted to the angles.

The bottom lateral rods are discontinued where the top and bottom chords unite, and the stress in the center panels is carried by the top laterals only. These are loop-ended square rods engaged between pairs of angle clips, as are the sway rods. The



lower lateral rods have split loop ends, which engage the wing plates on the chord pins and pass through clearance notches in the ends of the strut webs. The very shallow floorbeams are plate girders only 12 inches deep, which at each end cantilever  $7\frac{1}{2}$  feet beyond the truss centers. The roadway, 20 feet wide in the clear, has a floor of crossed diagonal planks. The 2-inch upper layer is laid close, and the  $1\frac{1}{2}$ -inch lower layer has 2-inch spaces. They are spiked to 3 x 12-inch longitudinal joists 12 inches apart

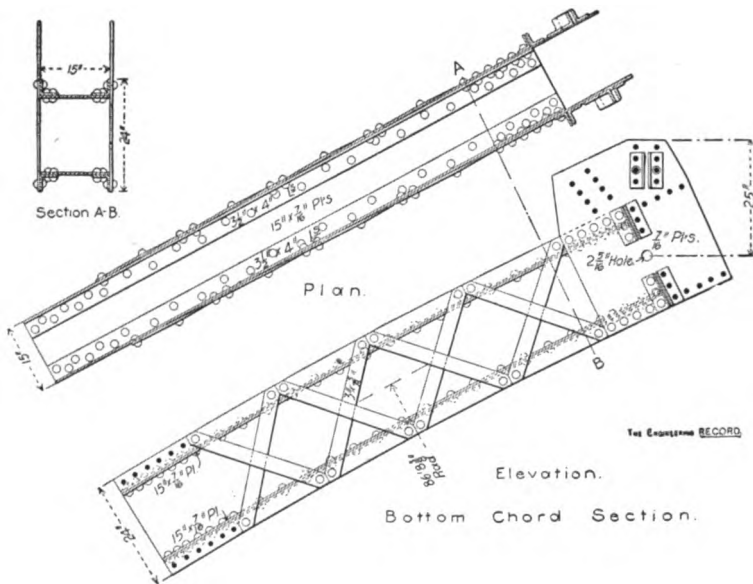

seated on transverse filler strips crowned  $2\frac{1}{2}$  inches in the center. The curb timbers are faced with 3 x  $3\frac{1}{2}$ -inch angles, and the sidewalk floor is laid with 2-inch transverse planks.

The highway bridge across the Noce ravine at St. Giustina, Tyrol, described in "The Engineering Record" of March 15, 1890, is remarkable for its great height of about 453 feet, nearly or quite unprecedented for such a structure. It is 222 feet long between abutments by  $19\frac{1}{2}$  feet wide, and has two-hinged trussed arch ribs of 40 feet rise and 197 feet span. The arch ribs are in vertical planes, and are connected by lateral bracing in the planes of the lower chords, by sway bracing in the transverse planes of the vertical members, and by the floor system. The floor system has light latticed transverse beams about 13 feet long, and 3-foot sidewalk cantilevers. The skewback hinges are convex steel bearings in cast-iron pedestals and shoes. All other connections are riv-

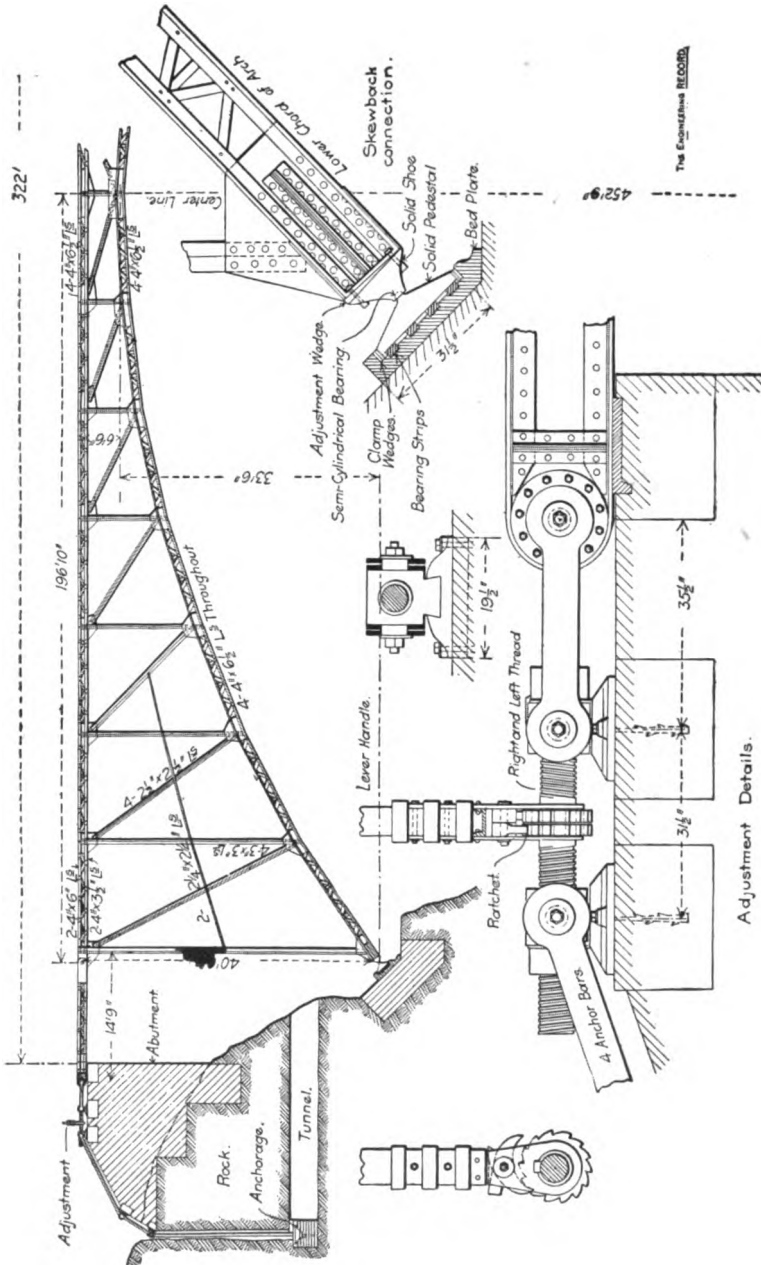

THE NOCE BRIDGE, ST. GIUSTINA, TYROL.

eted, and all truss members are made of four angles each, the top and bottom chords being latticed. The stringers are anchored at one end of the span, and at the other are provided with a truly remarkable temperature adjustment. Each stringer has a reinforced web pin-connected to two horizontal eye-bars, the opposite ends of which engage a sliding nut on a large screw. At the other end of the screw there is a duplicate connection to the upper eye-bar of an anchorage chain. In the middle of the screw there is a ratchet lever by which it can be turned to increase or diminish the distance between the eye-bars. As the temperature varies, this apparatus is operated by hand to maintain the uniformity of the connection with the anchorage and "prevent oscillations." The bridge weighs 95 tons, and was erected by the cantilever method, materials being handled by a cableway across the ravine.

## CHAPTER IV.

### FAIRMOUNT PARK, MENOMINEE AND SALMON RIVER BRIDGES. SPANS 200 TO 270 FEET.

The highway bridge over the Schuylkill River in Fairmount Park, Philadelphia, has four spandrel-braced, three-hinge arches

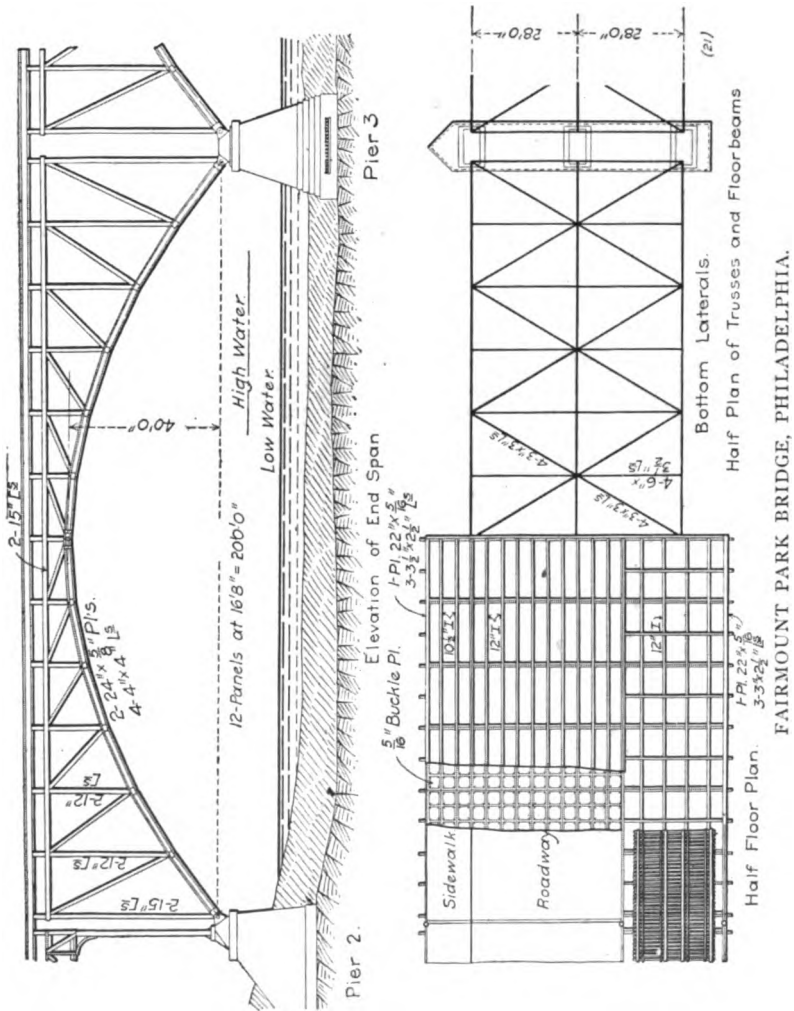

FAIRMOUNT PARK BRIDGE, PHILADELPHIA.

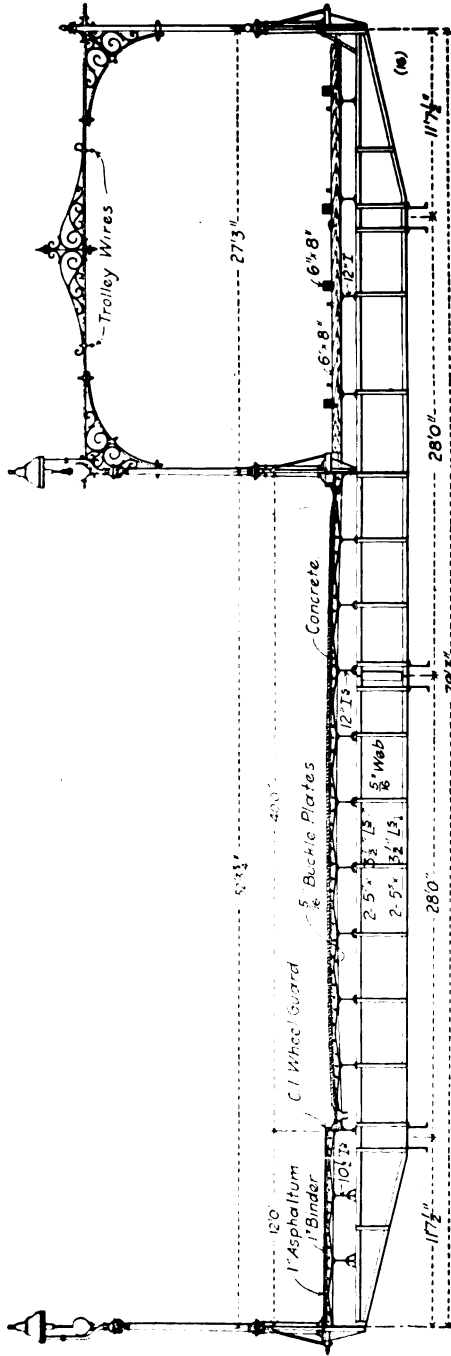

General Cross-Section.  
FAIRMOUNT PARK BRIDGE.

of 200-foot span and 40 feet rise on centers of pins. It has three trusses which are 28 feet apart on centers, and 6 feet deep at the crown. It is 76 feet wide in the clear between hand-rails, has a grade of 1.20 per cent and a maximum height of about 76 feet from roadway to low-water level. The estimated steel weight and cost were about 6,000,000 pounds and \$375,000, including superstructure. It is made of medium steel, and the heights of the successive spans increase  $7\frac{1}{2}$  feet on account of grade.

The floorbeams and stringers are proportioned to carry a loading of 100 pounds per square foot over all parts of the sidewalk and driveway, or a 20-ton load on a wheel-base of 9 feet, on any part of the driveway, and for 1000 pounds per linear foot of the railroad tracks, or an electric car weighing 25 tons loaded followed by another car weighing 20 tons loaded, on a total wheel-base of 78 feet.

The trusses carry the full area of the sidewalk and driveway over the whole span loaded with 80 pounds per square foot, and 1,000 pounds per linear foot over each railroad track.

Each truss has twelve equal panels, and all its members are made of pairs of channels, latticed on both flanges. The bottom chord has a uniform section throughout, made of two built channels, each composed of one  $24 \times \frac{5}{8}$ -inch web-plate and two  $4 \times 4$ -inch flange angles. All other members are made of rolled channels 12 or 15 inches deep. All truss joints are made with double gusset plates shop-riveted to the chords and field-riveted to the web members. The crown hinge is made with a 12-inch pin, having half holes in the lower chords and full holes in the gusset plates. The abutting ends of the lower chords have a wider clearance at the bottom than at the top edges, so that the inclined faces make angles of about 3 degrees and 49 minutes each with the vertical. The gusset plates at the center joint of the top chord are shop-riveted to one chord and bolted through slotted holes in the other chord, so as to make an expansion joint. The 10-inch skewback hinge pins have half-hole bearings in the ends of the lower chords, and are locked to the pedestals by full holes in the gusset plates.

The trusses are braced together by the solid steel-plate floor system, by vertical transverse sway bracing at every panel point, and by the lower chord lateral system, which consists of horizontal transverse struts at all panel points and X-bracing in double panels. All of the lateral struts and diagonals have I-shape cross sections made of two pairs of angles back to back latticed. At

the center six panel points, the sway bracing consists of intersecting zigzag angles latticed between the bottom strut and the floor-beam, virtually making lattice girders. Elsewhere it consists of X-bracing of single angles in the panels made by the vertical posts, floor beams and bottom transverse struts. The floorbeams are plate girders 3 feet deep and 79½ feet long over all. They are seated across the top chords at panel points, and the ends are tapered to a point beyond them where they form cantilever brackets, with a clear overhang of nearly 11 feet.

They carry the roadway on nine lines of 12-inch, 120-pound I-beams, 4 feet apart. Each of the two street car tracks is carried on two lines of 12-inch, 120-pound I-beams 6 feet apart. The sidewalk has two lines of 10½-inch, 76½-pound I-beams. There

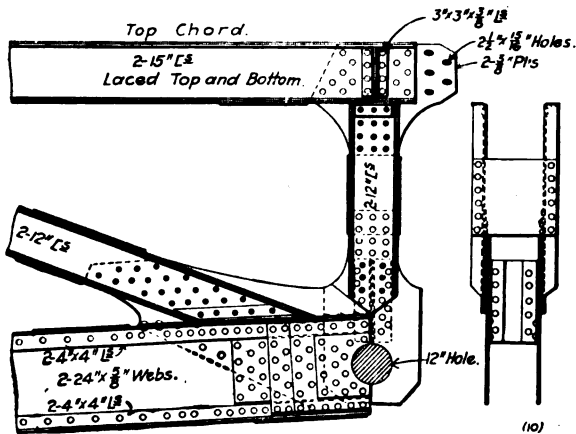

Center Panel and Crown Hinge.

are plate girders for the curbs and for fascia girders at the ends of the floorbeams, the latter having transverse vertical plates riveted to their web stiffeners to make knee braces for the hand-rail posts. The roadway and sidewalk stringers are seated on cast-iron chairs to give them the proper elevation and crown. They are covered by buckle plates in transverse strips riveted to them convex side up. They are leveled up with concrete covered with 1 inch of binder. This is finished with asphaltum, which is 1 inch thick for the sidewalk and 2 inches thick for the roadway. The hand-rail has cast-iron posts and gas-pipe frame, and there are ornate cast-iron lampposts both sides of the trolley tracks, to carry ornamental portals of steel scrollwork, from which the trolley wires are supported.

The skewback pins engage riveted steel pedestals, which have bases normal to the lower chord end sections, and are bolted to cast steel seats on the masonry piers. On the intermediate piers these seats are large, hollow boxes with braced webs.

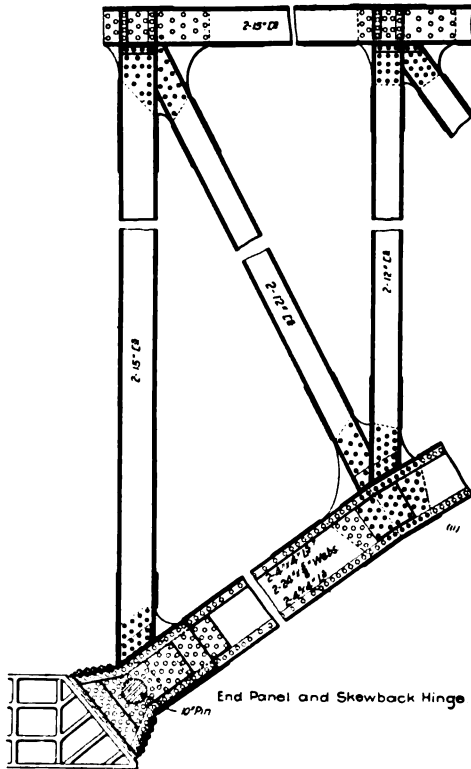

They are made in halves bolted together with turned 1½-inch bolts, and receive the balanced thrusts from the adjacent arches. They are seated on 7 x 10-foot base plates 1½ inches thick, which are anchored with six 2½-inch vertical bolts about 20 feet long, to a reaction platform of crossed tiers of rails built into the concrete footings.

The erection of the bridge was described in "The Engineering Record" of June 4, 1898, and was accomplished with ordinary fixed trestle falsework. The bents correspond approximately with the panel points, and each had a lower story consisting of eight piles cut off 22 feet above water-level, above which they were X-braced transversely. The framed bents of the upper story each consisted of three vertical posts X-braced transversely,



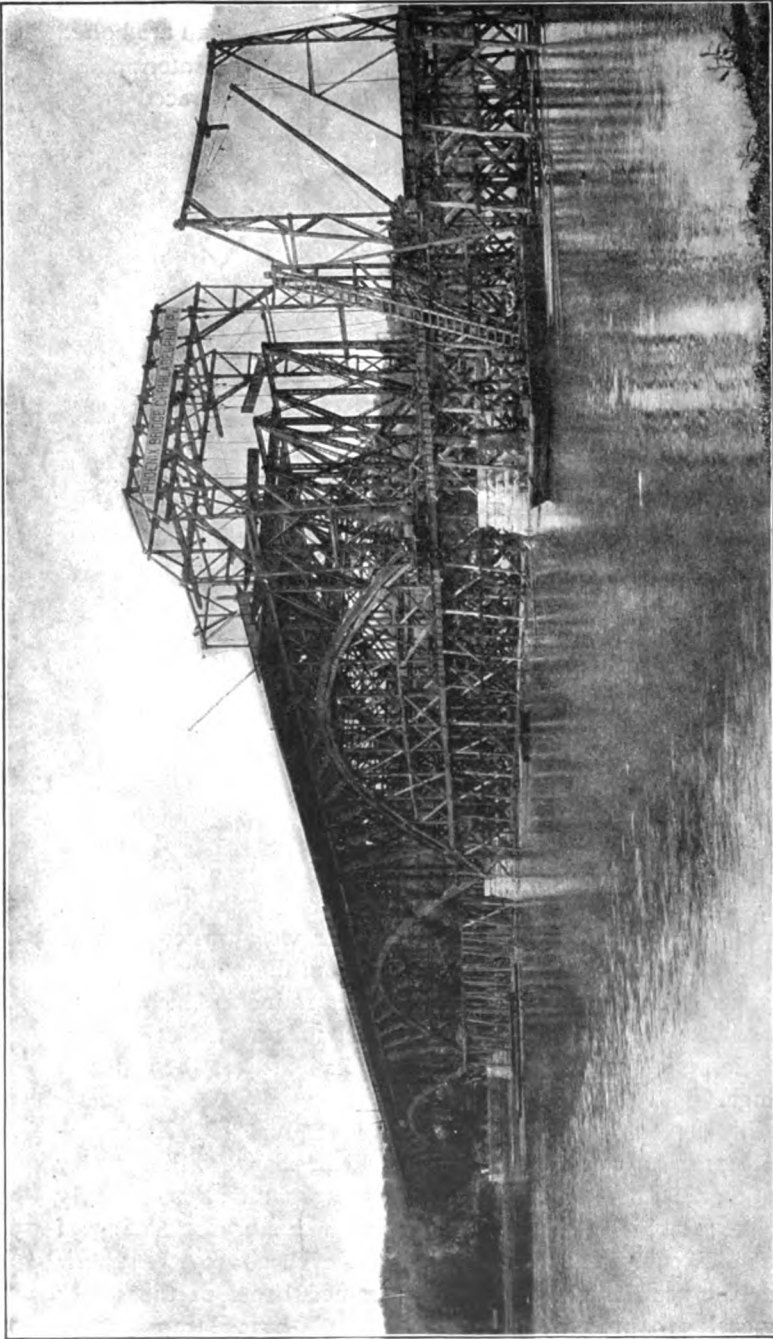

ERECTION OF 200-FOOT SPANS ACROSS THE SCHUYLKILL RIVER, FAIRMOUNT PARK.

and supporting the lower chords by cross pieces and camber wedges on double lines of inclined stringers parallel to them and notched over their caps. The pile caps projected 9 feet beyond

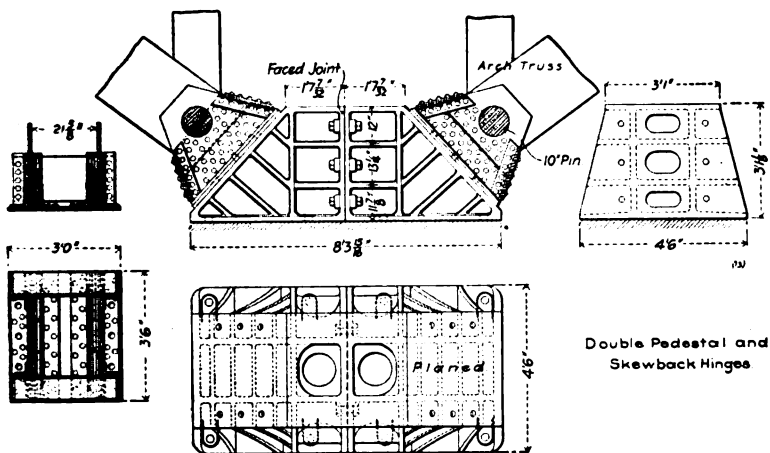

the upper falsework on each side, to carry the standard-gauge traveler tracks. Alternate panels of the falsework were X-braced longitudinally to make towers.

The wooden traveler had a strident two-bent tower about  $84 \times 50 \times 72$  feet in extreme dimensions. It had a clearance about 60 feet wide and 62 feet high. The tops of the braced posts were connected by and braced to combination Howe trusses 10 feet deep and 80 feet long, from which hoisting tackles could be suspended. These trusses supported a cantilever overhang 23 feet long on the rear side of the traveler, which was proportioned for a 10,000-pound load at the extremity. Guyed working platforms were cantilevered out from the outsides of the traveler posts just above the tracks. Material was delivered on top of the finished structure, and the traveler receded from it after setting the long floor-beams and stringers in place from its overhang.

The single-track deck bridge of the Superior Division of the Chicago, Milwaukee and St. Paul Railway, across the Menominee River, near Iron Mountain, Michigan, replaces a deck Pratt truss bridge of 225-foot span which had become too light for the service. It has short plate girder approaches and a 207-foot skew three-hinge spandrel-braced main arch span, with a rise of about 46 feet, center to center of crown, and skewback pins, and about 52 feet, center to center of top and bottom chords. The trusses are 22 feet apart on centers, and are connected by transverse

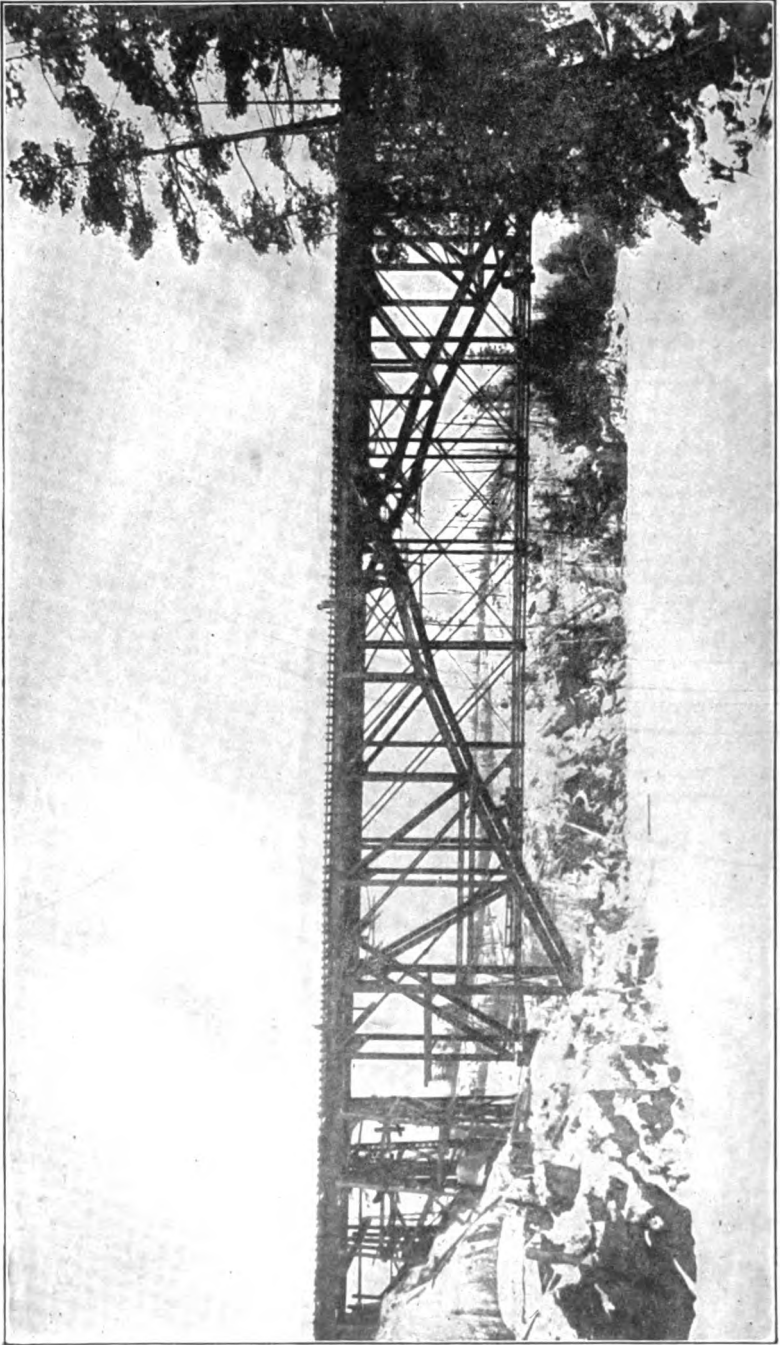

SINGLE-TRACK, 225-FOOT SPAN ACROSS MENOMINEE RIVER.

struts at lower chord panel points and at intermediate points of the two longest vertical posts, by top and bottom lateral X-bracing, and by X-bracing sway angles. The bottom struts and lateral diagonals have I-shape cross sections made of pairs of angles, back to back, latticed and riveted to horizontal connection plates on both flanges of the bottom chords. The top lateral diagonals are single angles riveted to horizontal connection plates, engaging the bottom flanges of the floorbeams and the top flanges of the top chords.

The top and bottom chords are made of built channels, latticed, and all vertical and diagonal web members are made of pairs of channels latticed, except the diagonals in the panel next the center, which are made with eye-bars. All connections are riveted, except at the crown and skewback hinges, which have  $9\frac{1}{8}$ -inch pins, and at the eye-bars, which have 4 5-16-inch pins. The floorbeams have their top flanges flush with the bottom flanges of the top chords, and are connected with 42 rivets in each end to the webs of the vertical posts. The stringers are seated across the floorbeams, and have their top flanges stayed with diagonal braces to the top flanges of the top chords. The top and bottom chords converge to intersect at the crown hinge pin about 6 feet below the center line of the horizontal part of the top chord. The trusses are in vertical planes, and the skewback pins are set in cast-steel pedestals with horizontal and inclined bearings on the concrete abutments, which are built on the solid granite banks of the river.

The bridge was built to Cooper's specifications of 1901, and was proportioned for a 7000-pound train load preceded by two 177½-ton consolidation locomotives, with 25,000, 50,000 and 32,500

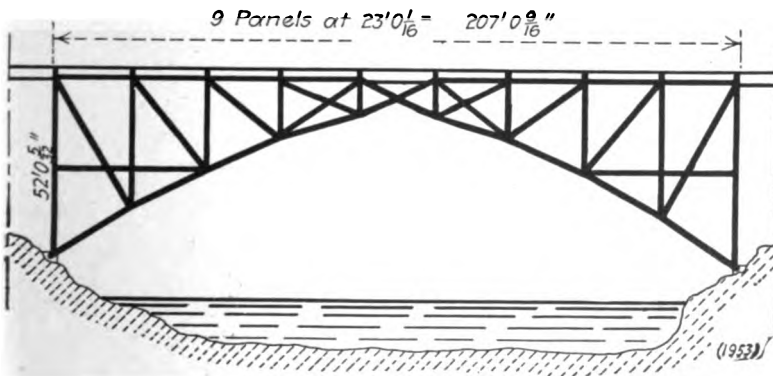

MENOMINEE SINGLE-TRACK BRIDGE.

pounds loads, respectively, on each truck, driver and tender axle. It was built of medium steel, and weighed about 650,000 pounds. The heavy loading was assumed to provide for iron-ore traffic.

The first design was for the crown hinge pin in the line of the parabolic lower chord, but this gave such large reversed stresses in the web members that the lower chord curve was changed to a hyperbola, and the crown hinge pin was placed midway between the top and bottom chords, thus avoiding the large reversed stresses and securing a much lighter structure for the

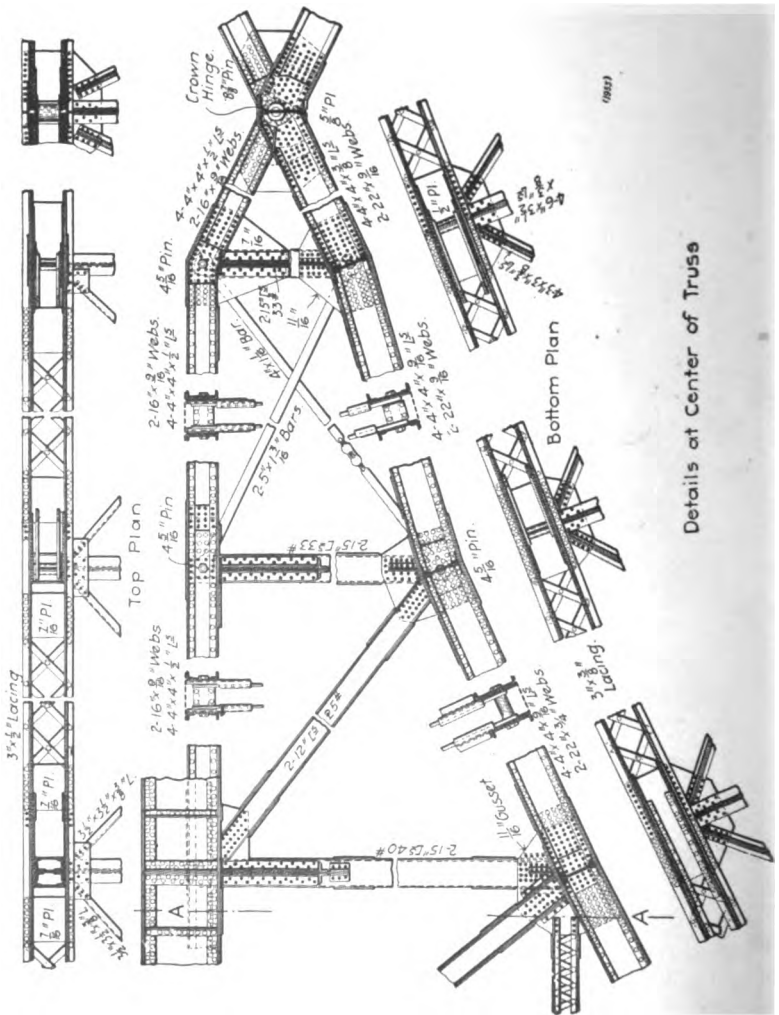

MENOMINEE BRIDGE.

same strength. A third design was made for a two-hinged arch with a hyperbolic lower chord, and, as the weight was computed to be between the weights of the first two, it was abandoned in favor of the second one, which was constructed as here illustrated. The principal advantages of the adopted design are

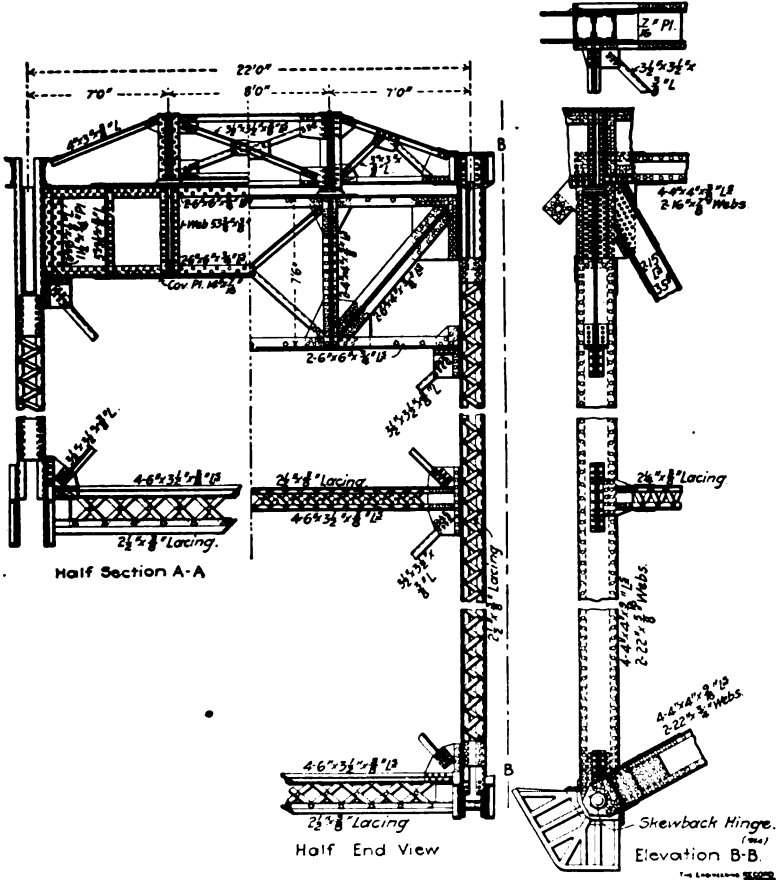

MENOMINEE BRIDGE.

economy, simplicity of shop work and erection and the absence of ambiguity of stress in any of the members.

The bridge was built without interfering with the traffic on the 255-foot deck Pratt truss span on the same site which was built in 1885. It was erected by the cantilever method, with temporary anchorages for the semi-spans, one of which was secured to a box filled with sand, and the other to beams set in the solid

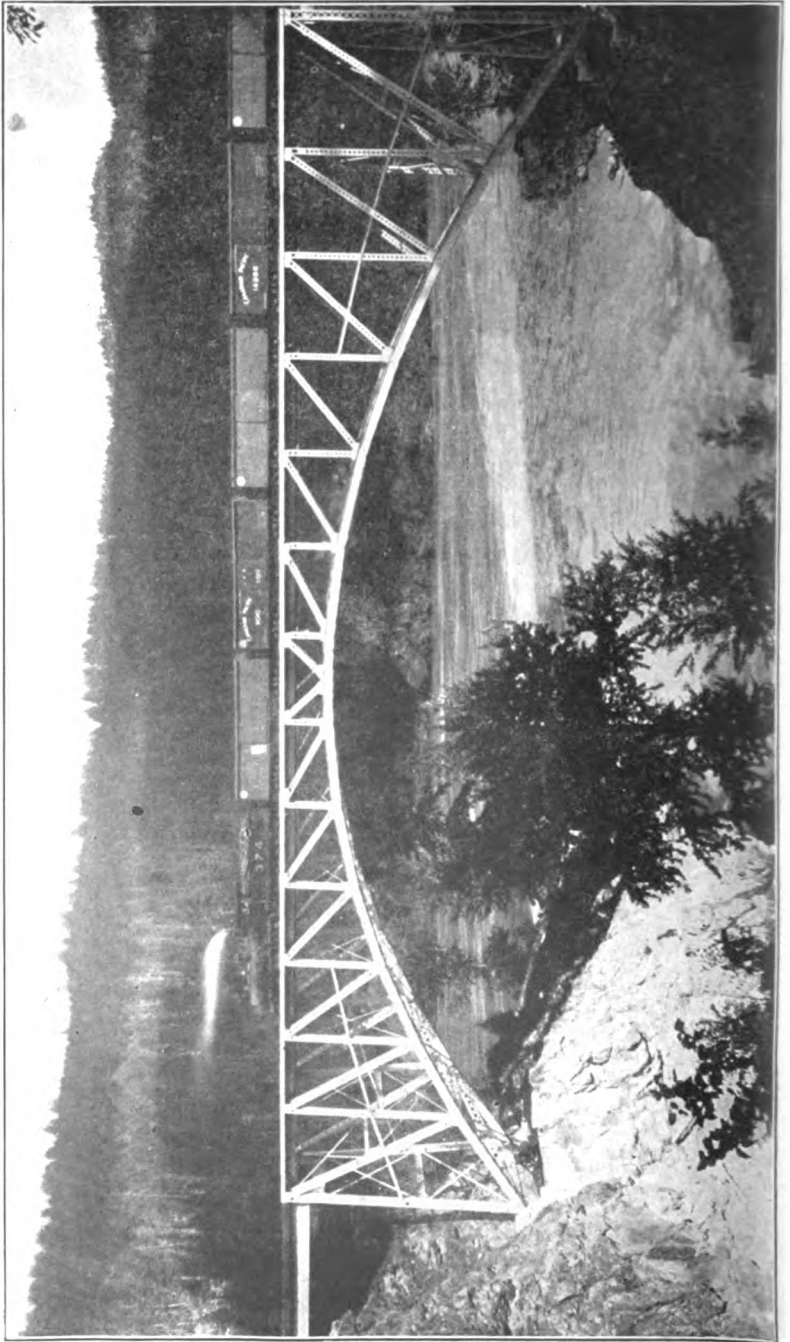

MUSKOGEE BRIDGE, 200 FEET SPAN, OVER EAST MOUNTAIN RIVER, CALIFORNIA.

rock. The anchor bars were pin-connected to the tops of the end posts through temporary web plates, which were afterward cut off. Adjustment was provided by a screw toggle near each anchor, and no difficulty whatever was experienced in making the center connection.

The single-track bridge of the Canadian Pacific Railway across the Salmon river has a 270-foot, three-hinge spandrel braced arch span and short plate girder approaches. The trusses are 60 feet  $3\frac{3}{8}$  inches deep at the ends, 10 feet  $6\frac{3}{8}$  inches deep at the crown and 16 feet apart at the horizontal top chords, on center lines. They are battered 1:10, so as to be 28 feet apart at skew-backs. The abutments of ashlar masonry are seated in terraces cut out of the steep hill sides about half way up, so as to carry the track at an elevation of about 123 feet above the water and give the trusses a center clearance of about 110 feet above summer water level. The trusses have a 30-foot panel at each end, a 10-foot panel each side of the crown hinge, and ten intermediate 20-foot panels.

The top chord has a rectangular trough shape cross section made throughout with a pair of 12-inch channels and a 22-inch top cover plate 5-16-inch thick at the crown and ends and 9-16-inch thick at the quarters. The bottom chords are made with two built channels, latticed on both flanges. The channels have a 24-inch web plate, a  $6\frac{1}{2}$  x 4-inch top flange angle and a  $4\frac{1}{2}$  x 4-inch bottom flange angle, and, except in the center four panels, are reinforced by a 13-inch web plate between the flange angles. All web members are made of pairs of built channels, latticed, with their webs transverse to the bridge axis, and are field riveted at both ends to wide gusset plates field riveted to the insides of the chord webs. The web plates of the vertical and inclined posts do not extend quite to the extremities of the members, but are cut off to clear the connection plates. The ends of the angles project beyond them to form jaws, which, in the vertical posts, engage the insides, and in the inclined posts engage the outsides of the truss connection plates so that they clear at intersections. At the ends of the trusses the longest web members are stayed at their middle points by longitudinal struts composed of a pair of 6-inch channels, latticed, which are field riveted to them at intersections and approximately bisect the angles between the top and bottom chords.

The top chords are spliced with web and cover plates in each panel. The splices are made on the side towards the center, and



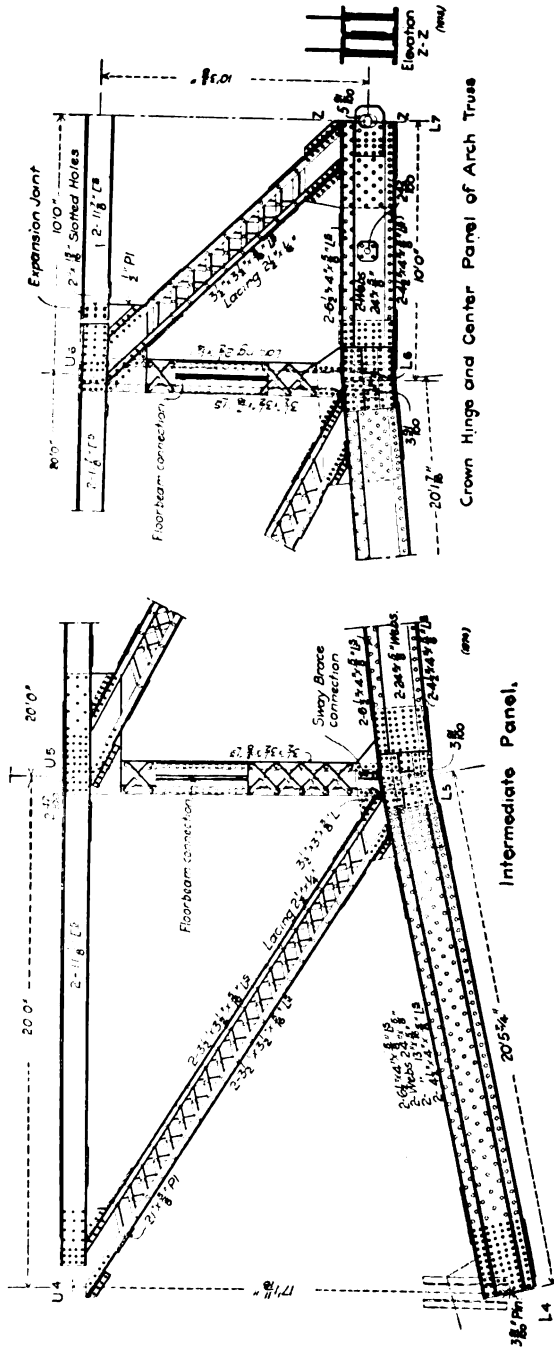

are about a foot from each panel point, except in the center panels, where the distance is 2 feet, and provision is made for an expansion joint by slotting the holes in the center sections, else-

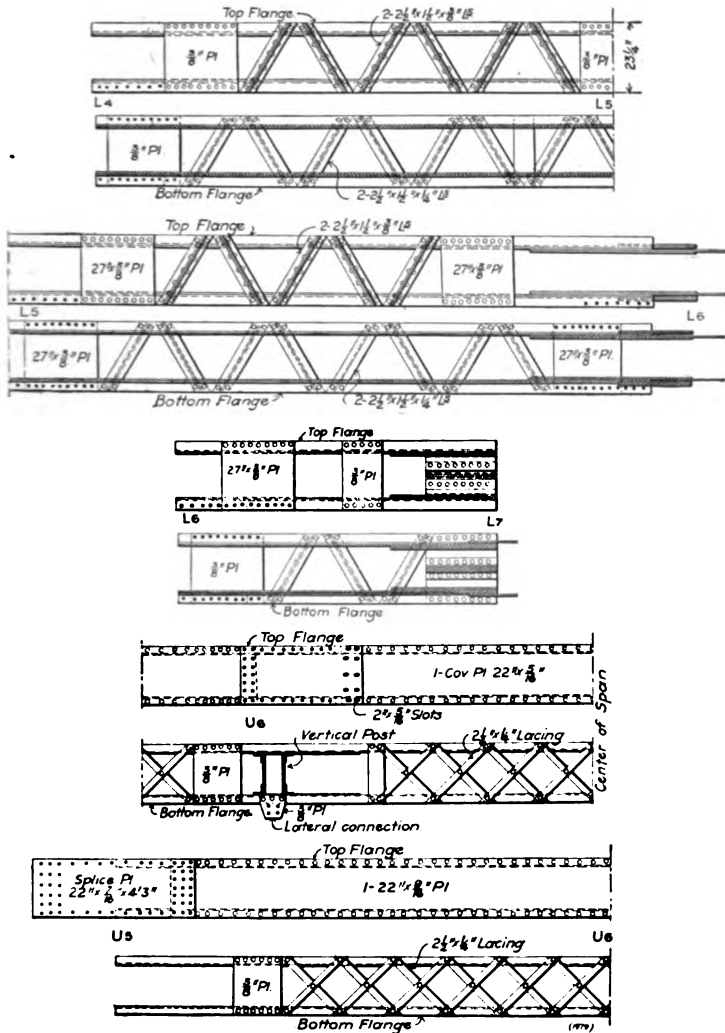

Top and Bottom Flanges of Chords.

SALMON RIVER BRIDGE.

where all joints are field riveted solid, and the splices are calculated to take the full chord stresses. The bottom chords are spliced on the panel points, and the ends are planed radial with a

slight clearance. In both top and bottom chords the inside web splice plates are made deeper than the chords to serve as connection plates for the web members, and are partly shop-riveted to one member so as to serve as jaws for the connection of the chords by 4-inch pins during erection, after which they were riveted up, except at the center point of the bottom chord, where there is a 6-inch hinge pin.

The 7-inch skewback pins engage half holes in the ends of the lower chords and full holes in the jaw plates on the vertical posts and in the two middle webs of the shoes. The two outer

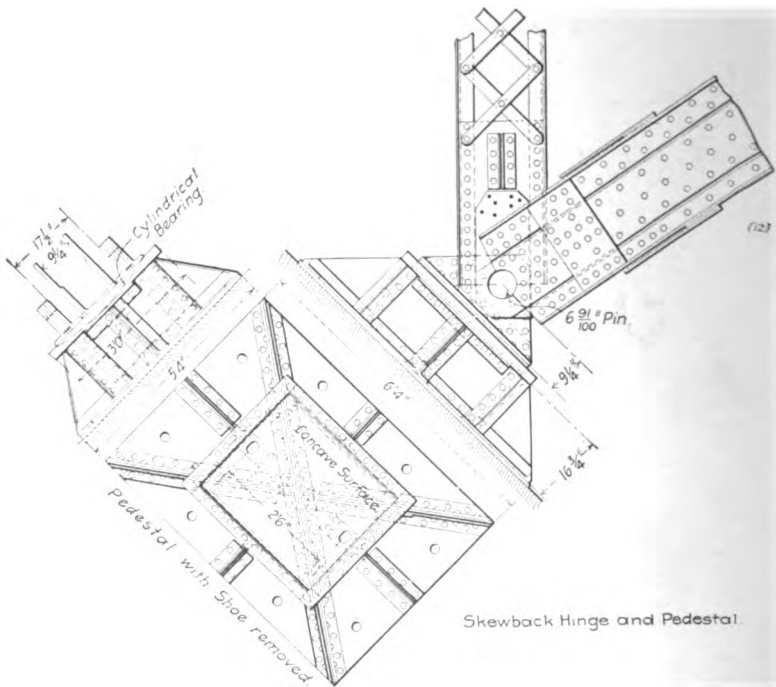

webs of the shoes have half holes and are reinforced to give a total length of pin bearing of 5½ inches. The shoes have base-plates 2¼ inches thick, finished to a cylindrical surface with a 6-foot radius. The axis of the cylinder is parallel to that of the bridge, so as to allow the truss bearing to be adjusted in conformity with the batter. These convex surfaces engage corresponding concave seats in the tops of the pedestals, which are transverse with the bridge axis on seats in planes perpendicular to it, thus securing simple masonry construction and automatic adjustments

to angle and batter. The pedestals have  $4\frac{1}{2} \times 8$  1-3-foot bases, and are made with longitudinal and transverse webs under the edges of the shoe. These form a rectangular box about 3 feet long and  $2\frac{1}{2}$  feet wide, covered by a cap plate  $2\frac{1}{4}$  inches thick, which is additionally supported by intersecting diaphragms on the diagonals of the base plate. The sides of the box are stiffened and the pressures are farther distributed over the full area of the base plate by knee-brace webs in the center of each side.

The trusses are braced together by the floorbeams and by bottom transverse struts at all lower chord panel points, and by intermediate transverse struts in the three end panels. The panels between transverse struts are X-braced by single  $3 \times 3$ -inch

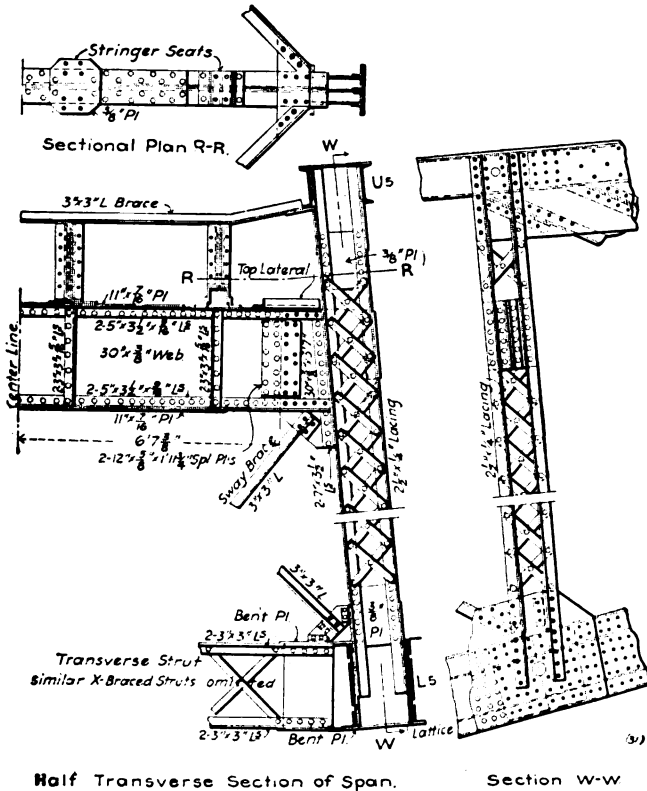

Half Transverse Section of Span.

Section W-W

angles. The top lateral struts are single  $3 \times 2\frac{1}{2}$ -inch angles riveted to the floorbeam flanges. The bottom lateral diagonals have I-shaped cross sections made of two pairs of angles back to back, latticed. The bottom transverse struts have rectangular cross

sections made with four angles latticed on all sides. Both members have the same depth as the bottom chord, and are connected to it by plates riveted to its flanges on both sides of the pin points.

The 30-inch floorbeams are web spliced to diaphragms projecting from the inner faces of the vertical posts about 3 feet in the clear below the top chords. The diaphragms are specially designed to extend continuously through the posts, and to permit this they are connected to their inner flanges by pairs of very wide angles, which take the place of the cover plates usually used, with pairs of angles on opposite sides. The track is carried on a center pair of main stringers seated directly on the top flanges of the floorbeams. The ties are very long, and their extremities are supported on the top flanges of an outside pair of stringers which are shallower than the track stringers, and are seated on bent-plate chairs on the floorbeam flanges. The stringers have no sway bracing or laterals, but their upper flanges are stayed by transverse angle struts across them, which are field riveted to the lower flanges of the top chords at panel points. The ends of adjacent stringers abut and are riveted together through their end web stiffener angles.

The bridge is built of medium steel, not reamed, and conforms to the specifications of the Canadian Pacific Railway Company. It is proportioned for a live load of two 106,000-pound locomotives each, with four 24,000-pound axle loads, about  $4\frac{1}{2}$  feet apart, followed by a train load of 3,000 pounds per linear foot.

## CHAPTER V.

### THE MIRABEAU, PANTHER HOLLOW, SURPRISE CREEK AND DRIVING PARK BRIDGES. SPANS FROM 326 TO 416 FEET.

The Mirabeau Bridge, Paris, France, described in the "Genie Civil" of May 9, 1896, carries Convention Street across the Seine, with a clear center height of 26 feet above the water, and is a deck structure, with a  $39\frac{1}{2}$ -foot roadway and two 13-foot sidewalks. It has a channel span of 326 feet and two side spans of  $131\frac{1}{2}$  feet, all center lengths. The middle span is a three-hinge spandrel-braced arch, with seven riveted trusses, which are continued over the piers to form cantilevers balancing the skewback thrusts and pin-connected at their extremities to the tops of short vertical rocker bents. They are connected together by the deck floor system, by transverse struts and lateral X-bracing between the bottom chords, and by transverse X-bracing between the vertical posts. The principal member of each truss is the arch-rib bottom chord, the intrados of which is a very flat parabola with a horizontal axis. The middle of the intrados for 134 feet is the arc of a circle of 630 feet radius, and the ends of it are tangents.

The chord has a peculiar cross section with two webs decreasing in depth from about 78 inches at the skewbacks to about

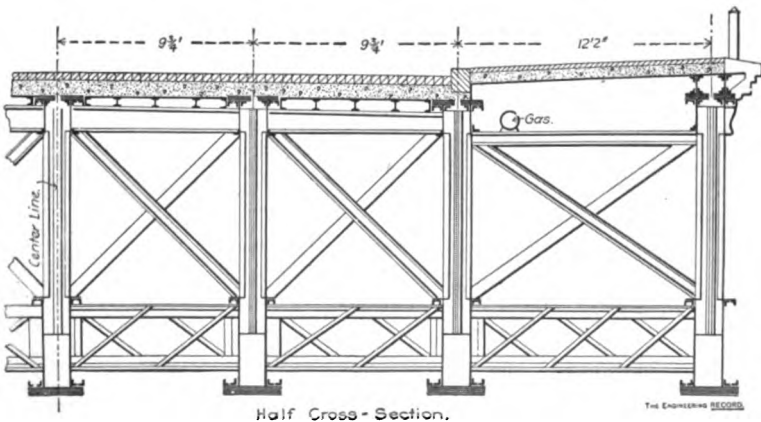

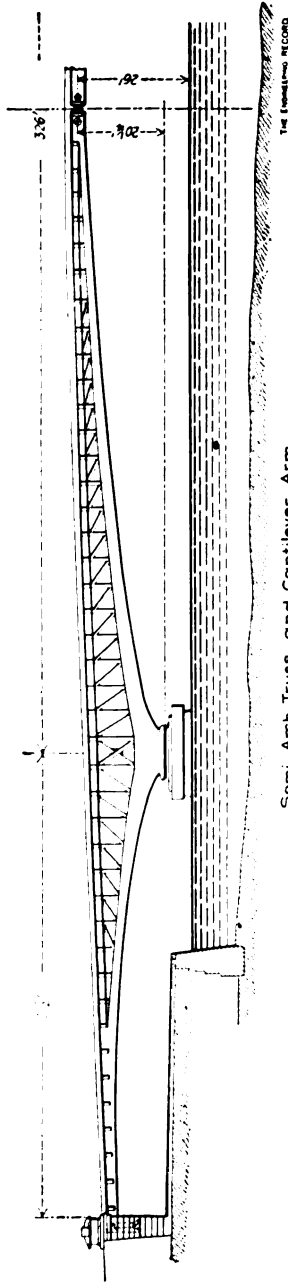

Semi Arch Truss and Cantilever Arm.  
MIRABEAU HIGHWAY BRIDGE.

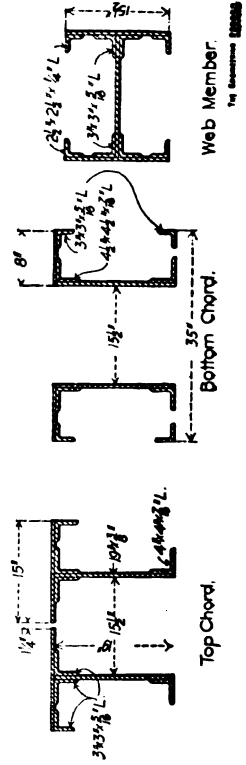

27½ inches at the crown, where it unites with the top chord to form a closed rectangular section. The webs have a constant thickness of 7-16 inch, except where they are reinforced to ⅓ inch over the piers. The cover plates have a total thickness of 3 inches at the skewbacks and 7-16 inch at the crown, for the main span, and 2⅓ inches at the skewbacks and 7-16 inches at the crown, for the side spans. All the flange plates are 35 x 7-16 inches. The horizontal top chords are each made in separate halves, each having an approximately T-shaped cross section, as shown in the detail. The cross sections of the chords are uniform except for the combined thickness of the top flange plates, which vary from 3 inches over the piers to 7-16 inch at the crown and at the extremities of the cantilevers.

The vertical and diagonal posts have the same I-shaped cross section with a uniform depth and a variable width of from 12 to 23

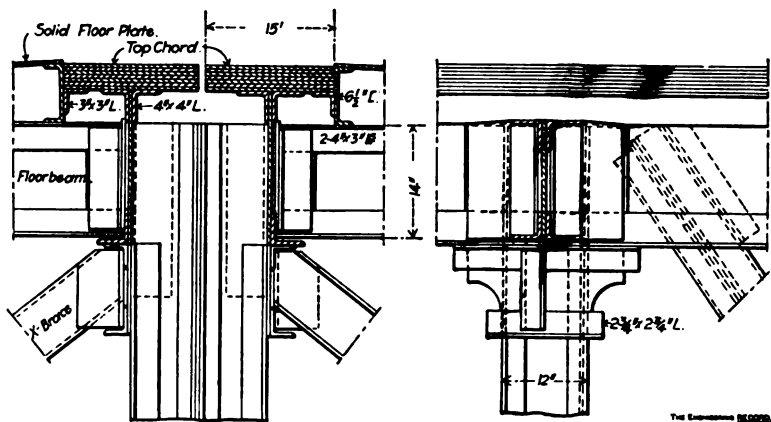

Details of Truss Members and Sway Bracing at Top Chord Panel Point.

inches for the former, and from 5¾ to 7½ inches for the latter. The outline of intrados of the bottom chord is continued to the vertex of the parabola in the upper surface of the pier masonry, but the lower flanges are tangent to the curve about 13 feet from the center of the pier, and abut against the horizontal transverse rib of the cast-steel hinge piece. This piece has two oblique arms engaging the under side of the flanges to which they are bolted. The ends of the flanges are planed and abut against keys driven between them and the bearing faces of the rib, which are about 15 inches wide, and provide horizontal bearing surfaces for the ends of the inclined center posts. The lower part of the hinge



casting has a segment of a transverse cylindrical surface 12 inches in diameter, which is seated in a concave steel casting keyed into a cast-iron bed-plate, recessed into the granite pier cap.

The crown hinge consists of a cast-steel transverse bar, flat

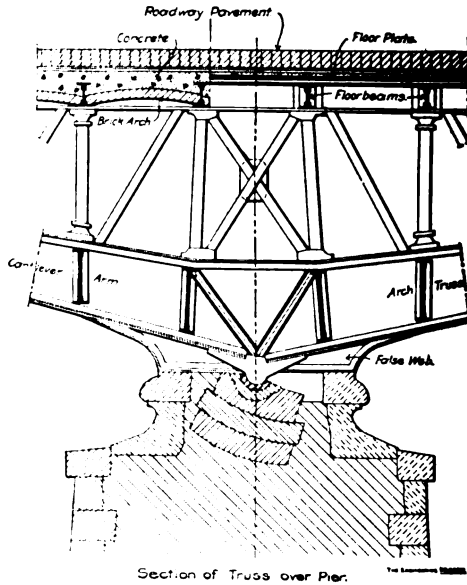

on one side and convex on the other, which is seated in a semi-cylindrical socket  $4\frac{1}{2}$  inches in diameter. The ends of the convex piece are turned round and engage holes in the jaws of two cast-steel bearing pieces, bolted to the ends of the semi-arch trusses.

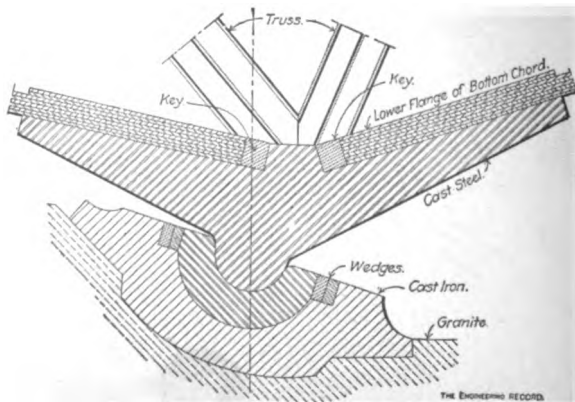

The seats on the trusses are vertical transverse flanges, each made of three steel castings bolted to the webs and flanges of the arch rib, and having additional bearing on a circular angle iron riveted to the outside of each web around a 12-inch bored hole. The outside trusses are decorated with ornamental cast-iron work; the skewback hinges are concealed by large figures in bas relief, which crown the pier tops, and a large sculptured escutcheon masks each crown hinge. The superstructure weighs about 6,037,000 pounds, was assembled on pile falsework and erected by traveling gantries which spanned the full width of the bridge.

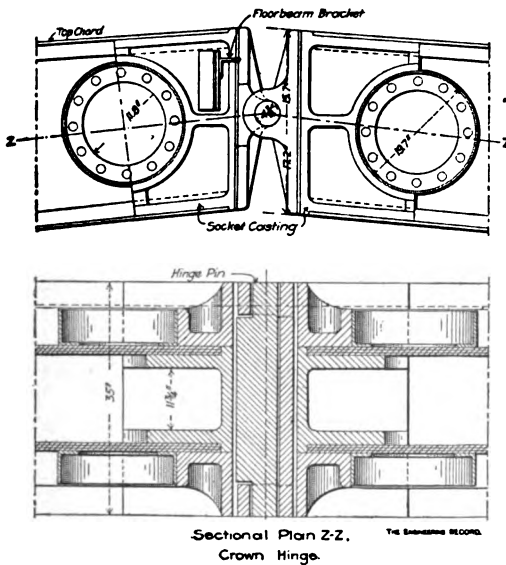

They had two overhead trusses, transverse to the bridge axis, supporting carriages on which trolleys with hand windlasses moved longitudinally and commanded the whole structure to handle its members and the hydraulic riveting machines.

The Panther Hollow Bridge is a steel and masonry structure situated in the beautiful Schenley Park, Pittsburg, Pa. It was illustrated in "The Engineering Record" of June 4, 1898, from which the following description is reprinted: It is of a class to which an increasing amount of attention is directed, as cities turn to the embellishment of their park spaces, and by reason of the nature of their surroundings and their intended use, architectural merit has to be considered in the design of such bridges, as well as structural excellence. This bridge crosses from the

Phipps Conservatory to the Speedway, and has a total length of about 620 feet. In the ravine which it spans are a railway and a small water course. The bridge has a main steel deck span constructed of four three-hinged arch trusses. Two symmetrical masonry approaches are formed by the abutment of the steel arch, which is carried up to the roadway as a pier 20 feet wide, followed by two 30-foot arches and an end abutment which terminates with two circular segmental wing walls curved outward. The end pedestals are surmounted by large bronze panthers. The principal dimensions of the main span are, length 360 feet, center to center of end pins, rise 45 feet, center height of bottom chord above ground 115 feet, width of roadway 40 feet, width of sidewalks 10 feet each.

The trusses are three-hinged arches, with one-seventh rise, designed to have their members act temporarily as pin-connected during erection, and afterward be solidly riveted together before

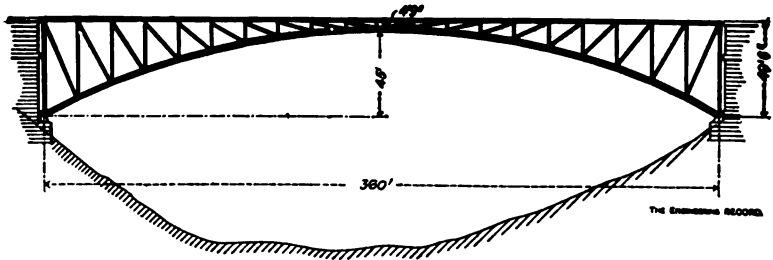

PANTHER HOLLOW BRIDGE, SCHENLEY PARK, PITTSBURG.

completion, so as to make a girder construction rigid throughout, to receive all live load, wind and vibration strains, etc. It was considered that by this arrangement all irregular initial strains would be eliminated, adjustments would be made, and accurate attachments secured by assembling the main points with connection pins through which the dead-load strains would be transmitted. The normal permanent increments and decrements of length due to constant load having been secured, bearings established and equilibriums attained, the splice plates of the joints were matched, their holes drilled or reamed in place to exact correspondence, and the rivets driven freely without any shearing or bearing strain, so as to provide rigid connections ready to develop action only when additional stress or live load was imposed, and then to receive it directly, while dead-load strains or their equivalent were still carried through the pins.

In the designer's analysis of the calculations of the arch trusses he states that "The parabola of the bottom chord corresponds to the form of a chain covered with an equally distributed load, consequently neither diagonal nor horizontal construction members are required for equilibrium for this condition, only the members are necessary that transfer the loads of the top chord to the chain. According to the assumption, the dead load is equally distributed over the span, and has consequently no influence on the diagonal and horizontal members; neither has the equally distributed live load. By special loading a maximum stress can be produced in each member, by contrary load a minimum stress, and as both together have to be equal to zero, maximum values will be equal to minimum values—only with different signs, either plus or minus—consequently only one of both needs to be calculated.

"In finding the limit between loaded and unloaded panels, the fact is considered that the resultant of one-half of the span will always pass through the two hinges, its direction is consequently known; the other resultant passes through the third hinge, and the respective panel point of that member, for which the condition of loading is to be established. Afterward the vertical and horizontal component of the pressure in the vertex (the middle hinge), is ascertained, and then the stress in the members is found in the usual manner. In figuring the maximum and minimum stresses for the verticals, it is considered that each vertical has beside the share for dead load also a panel of equally distributed live load to carry, but if the live load is so placed that it produces a maximum live-load strain, it will in reversed position produce a minimum stress. Both maximum and minimum stresses added will make a regular panel live load. For the calculation of bottom chord stresses the effect of dead and live load is to be considered. By corresponding location of the live load, the minimum stress will be found a small fraction greater than for equally distributed live load. It is not necessary to figure the maximum live-load stress, as it will always remain inside the compression line."

For the proportioning of the truss members the following formulas for unit stresses  $S$  are used:

For the bottom chord (all in compression)

$$S = 12,500 - 500 \frac{l}{v}$$

Where  $l$  = length of members in feet center to center of connection,

$v$  = least radius of gyration in inches.

For the web members and top chord (alternate tension and compression)  $S = 10,800$

$$S = \left( 1 - \frac{\text{Max. lesser strains}}{2 \times \text{max. greater strains}} \right)$$

For the floor system: Unit compression stress for rolled beams

$$S = \frac{11,500}{1 + .0288 \frac{l^2}{b^2}}$$

Unit compression stress for riveted girders

$$S = \frac{10,800}{1 \times .0288 \frac{l^2}{b^2}}$$

Where  $l$  = supported length in feet,  $b$  = width of flange in inches.

Assumed dead loads of floors in pounds per square foot: for roadway, Carnegie's trough section M10, 25, 3 inches of ashes 18; 2½ inches of concrete 25; 2 inches of asphaltum 17, total 85 pounds. For sidewalks, Carnegie's trough section M30, 11, 1½ inches of asphaltum 11, 2 inches hot binder 20, total 42 pounds.

Assumed live load per square foot: for floor system 150 pounds for roadway plus 100 pounds for sidewalk; for truss system 89 pounds for roadway plus 60 pounds for sidewalk. The estimated quantities included 2,016,465 pounds of steel, 8,000 cubic yards of masonry, 2434 square yards of asphalt pavement, and 1734 square yards of telford pavement, and the contract price was \$167,500.

The lateral braces and sway braces are all made of angles riveted at their connections, and there are no adjustable members or connections in the bridge. In the main truss the pins were calculated for a double dead load only, and after the bridge was swung the field holes for the rivets were reamed before riveting. These rivets were figured for a double live load only with the usual excess of 30 per cent., the main object being to have a rigid bridge, and all rivets in the lines of stress. The four trusses forming one-half of the bridge were completely assembled together on timber centering. The upper surface of the centering consisted of a platform conforming to and supporting the lower chords of the set of semi-arches, which were allowed to overhang one panel

at the crown. Then the other trusses were similarly erected to join them at the center.

The sidewalks are carried outside the main trusses by cantilever brackets, each of which has an end connection plate to receive the exterior horizontal longitudinal hand rail and cornice girder. The entire weight and thrust of the bridge is carried by the eight end shoes or skewback connections for the trusses. Each shoe is a riveted steel pedestal, receiving the end pin and distributing the reaction on the rigid horizontal and vertical bearing

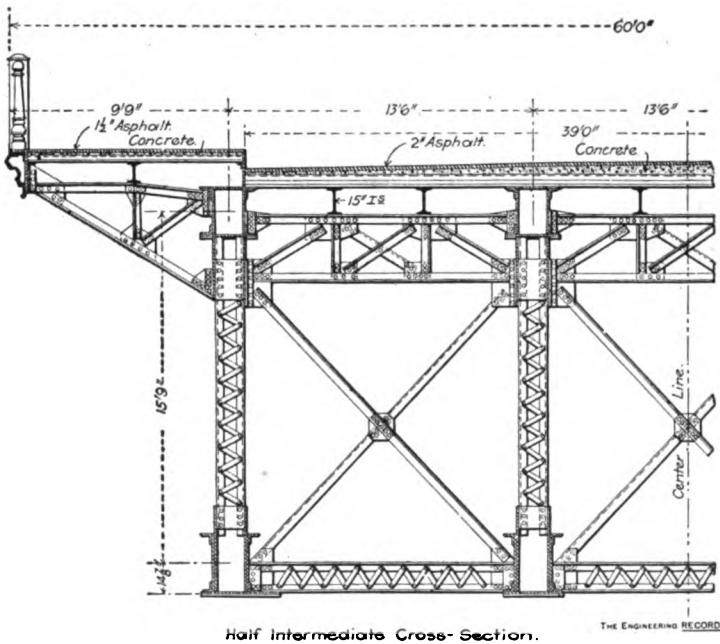

Half Intermediate Cross-Section.

THE ENGINEERING RECORD.

surfaces, which are bedded with lead plates on cut-stone seats in the masonry.

Twelve and 15-inch rolled I-beams are used throughout for sidewalk and roadway stringers. Each bottom lateral diagonal consists of a pair of angles (from 3 x 3-inch to 3 x 5-inch) riveted back to back with washers between and connected by four rivets at each end to oblique wing plates engaging the bottom chord pins. The bottom transverse lateral struts, 2½ feet deep, are I-shaped, made of two pairs of 3½ x 3½-inch angles latticed. The sway bracing in transverse vertical planes at panel points consists of pairs of 3 x 3-inch diagonal angles connected by bottom

plates, field riveted at the intersections, and attached to angle clips at the ends. The roadway troughs are riveted up into two sections, each bolted into slotted holes in the opposite edges of an

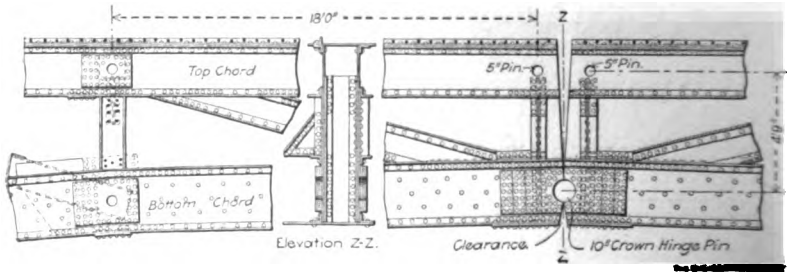

Crown Hinge.

11-inch transverse expansion plate 40½ feet long, which allows for temperature variations. The sidewalk paving is laid up to end curbs, each made of a vertical 15 x ½-inch plate with its edges

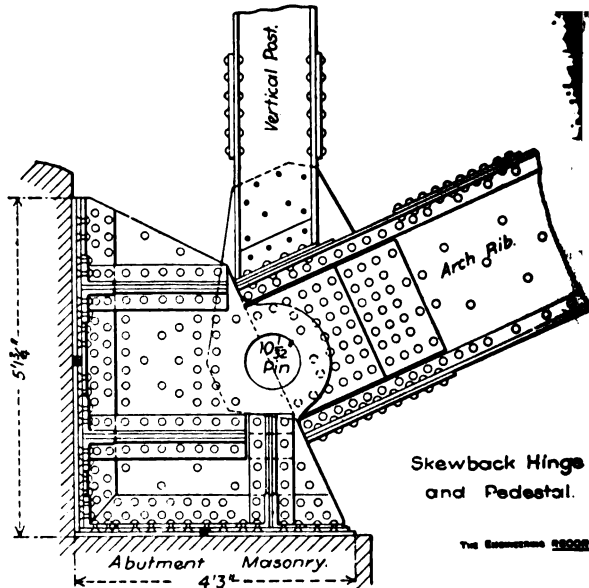

Skewback Hinges and Pedestal.

stiffened by angles and a horizontal base plate riveted on for anchorage to the abutment.

The Canadian Pacific Railway crosses Surprise Creek on a

single-track spandrel-braced three-hinge arch span about 180 feet high, which was described in "The Engineering Record" of July 16, 1898. There are two trusses, of 293 feet  $4\frac{1}{2}$  inches span

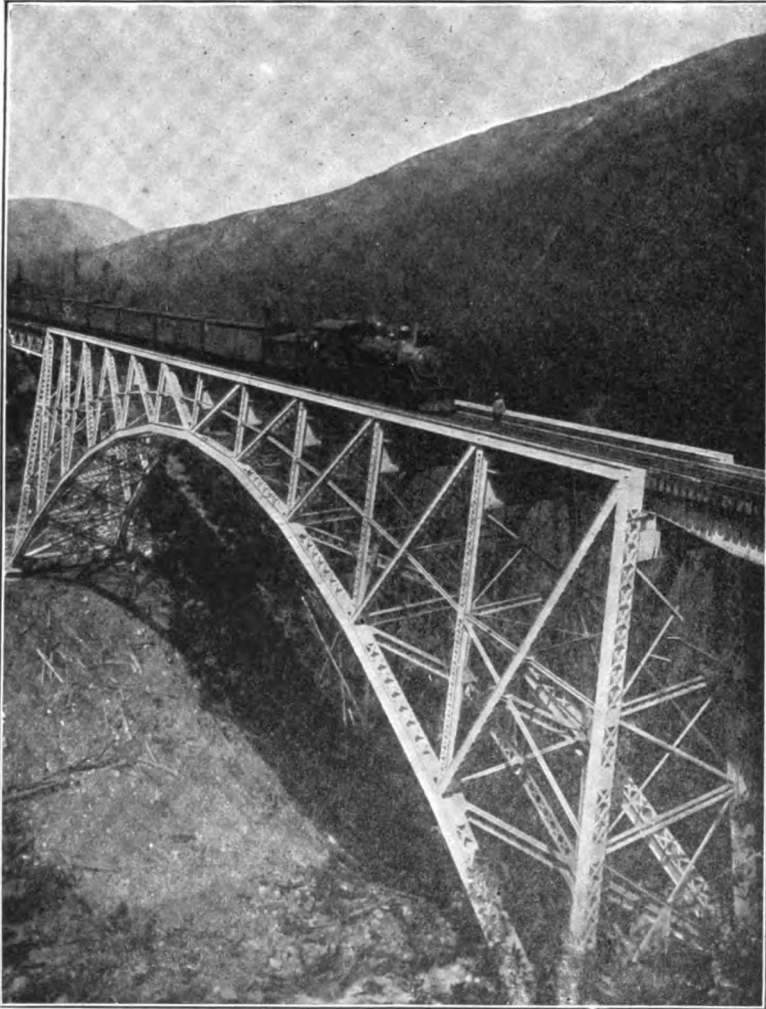

SURPRISE CREEK, 293-FOOT SINGLE-TRACK SPAN.

and about 80 feet rise, each battered 1:8 so that their top chords are 16 feet apart and the bottom chords 38 feet apart at the skew-backs. The straight top chord is on a grade of 2.2 per cent., and



this, together with the fact that the skewbacks are at different heights and that there are five panels on one side of the crown and six on the other side, gives the truss an unsymmetrical appear-

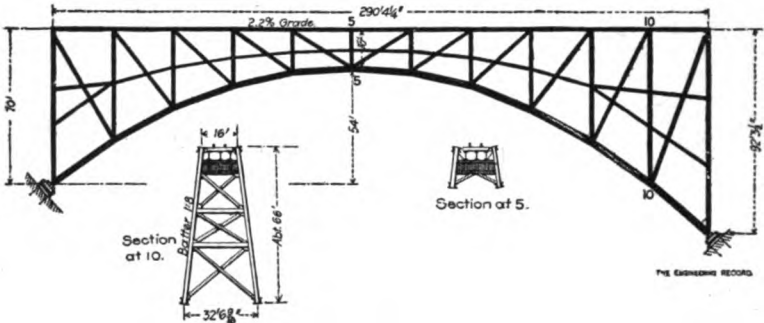

SURPRISE CREEK ARCH, CANADIAN PACIFIC RAILWAY.

ance. Both chords are pin-connected with full holes in the top chord web splices and half holes with clearance at the bottom chord panel points. The center lower chord pin forms the crown hinge and the center top chord pin has half hole open bearings

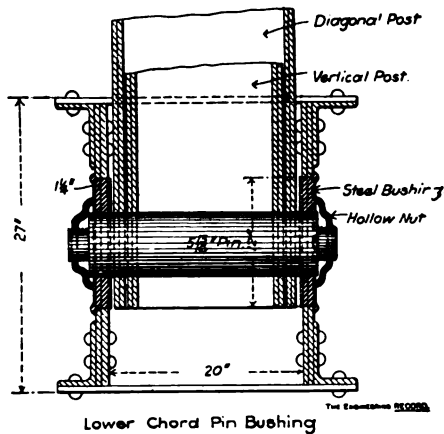

with expansion clearance between the ends of the chord sections. The floorbeams have web connections and kneebraces to the tops of the vertical posts. There are lower chord and intermediate horizontal transverse braces, and top and bottom chord lateral and vertical transverse X-braces. All members are compression

members and all secondary connections have riveted gusset plates and angle clips.

All truss pins are 6 inches in diameter, but this did not give sufficient bearing area in the lower chords, so the chord webs were bushed with steel discs, 12 inches in diameter. The end vertical posts are field-riveted to gusset plates, shop-riveted to the webs of the lower chords. The skewback hinges are ball and socket joints made with a spherical casting bolted to transverse flanges on the end of the bottom chord and engaging a concave

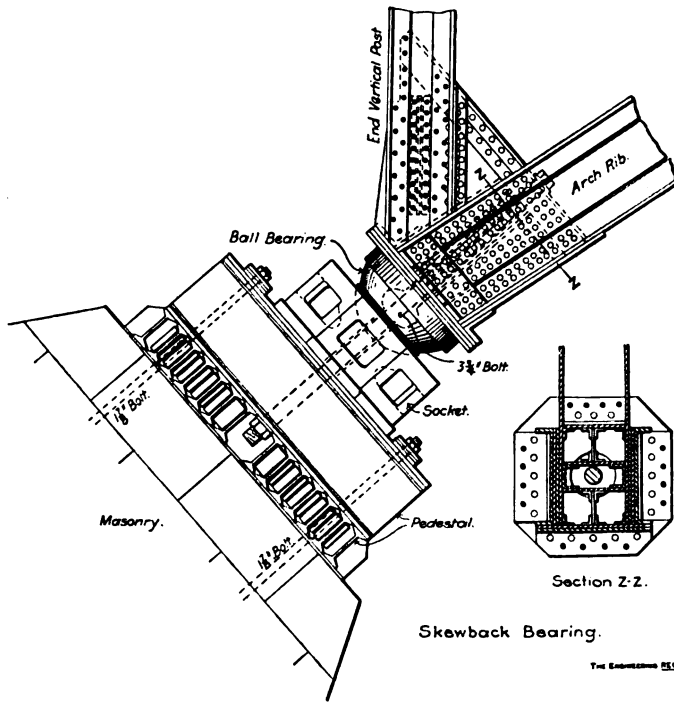

pedestal. The pedestal is seated on a 6 x 8-foot grillage of I-beams, anchor-bolted to the masonry, and the grillage, pedestal, shoe and chord are tied together by a 3 $\frac{3}{4}$ -inch bolt, 9 feet long, which passes through the center of the spherical joint and takes bearing at the upper end with a nut and a washer-plate across the ends of longitudinal diaphragms at right angles to each other, riveted to the webs and cover plates of the chord. The lower end of the rod has a nut bearing on a saddle plate across the flanges of the upper tier of grillage beams. The span was proportioned for a live load of 50,000 pounds at every panel, and weighs about

1,040,000 pounds. The trusses were erected on trestle falsework with bottom sills and two vertical and two batter posts in each bent; the falsework was carried up to top chord level and every third panel was braced to form a tower. All bents were made in panels 25 feet high.

About 600 feet below the falls at Rochester, N. Y., the Driving Park Bridge carries a city street across the Genesee River over 200 feet above the water. The bridge, which was described in "The Engineering Record" of July 18, and August 1, 1891, rises from solid rock ledges of red and white sandstone and blue

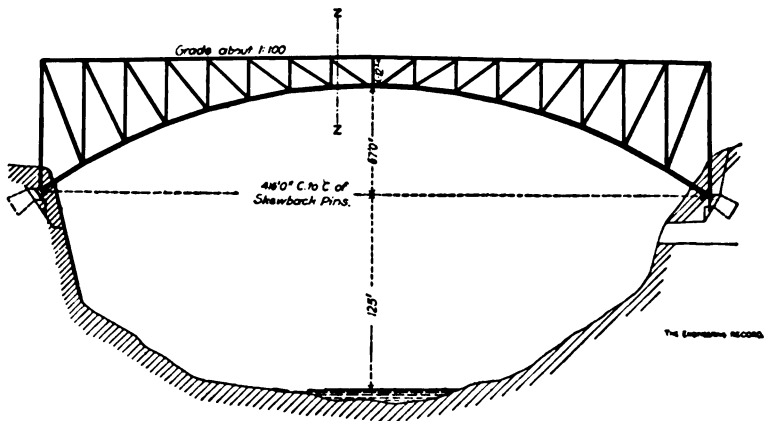

DRIVING PARK HIGHWAY BRIDGE, ROCHESTER.

limestone, which produce a very striking effect. The 416-foot main span has two three-hinge spandrel-braced arch trusses of 67 feet rise. The top chords are slightly inclined from the horizontal, and are 20 feet apart on centers, while the trusses batter so as to make the distance between center lines of bottom chords 46 feet at the skewbacks. The trusses are about  $80\frac{1}{2}$  feet deep at the skewbacks and 12 feet at the crown, and are proportioned for a live load of 90 pounds per square foot of floor and sidewalk surface. They are divided into 26-foot 9-inch panels, and the spandrel posts are braced by two lines of horizontal longitudinal struts connected by web splices, which are continuous across the post intersections. The verticals and diagonals are made with pairs of built channels, latticed, and the chords are made of the usual top chord section with bottom flange reinforcement plates projecting beyond the insides of the webs of the lower chords. The top chords are disconnected at the center of the span, where there are

expansion clearance and double floorbeams to provide complete lateral bracing. The bottom chords are also in two sections, making complete independent semi-trusses, united by the floor system and by the semi-cylindrical bearings of the lower chords on the crown hinge pin. At the crown the 24 x 30-inch rectangular bottom chord sections have their webs tapered and their cover plates converged toward the crown pin, making a flattened section, which is widened by an oblique center diaphragm with

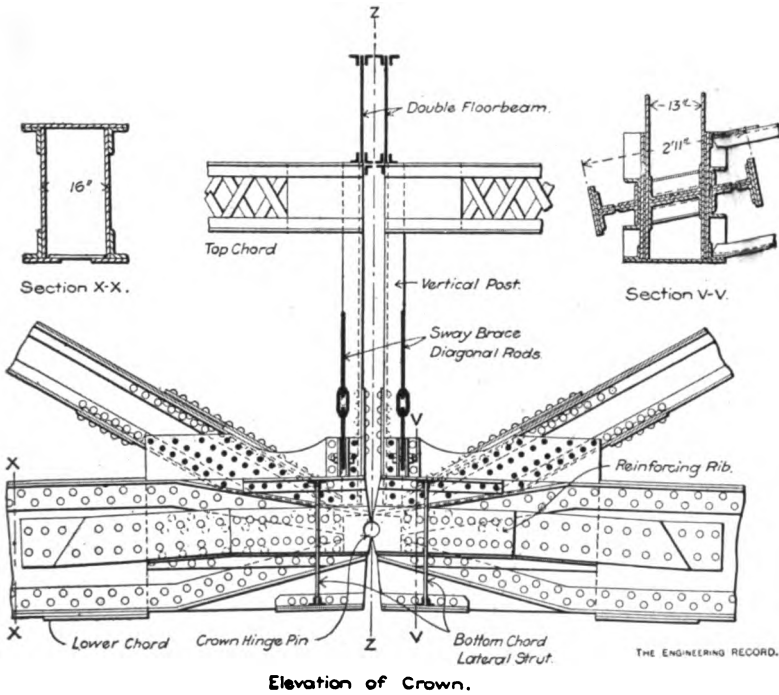

flanges, which virtually makes a wedge-shaped plate girder with horizontal web and flanges diverging from their connection to the chord webs. The web of the girder forms a continuous bearing for a steel casting which is enclosed by the projecting ends of the flange plates, and forms a trough or bushing for the full length bearing of the crown hinge pin, 4 inches in diameter and  $3\frac{1}{2}$  feet long. The ends of the chord sections are beveled to give clearance at the pin, and the center vertical post and bottom lateral strut are made double, one of each being riveted to each semi-truss.

The lower ends of the bottom chords are similarly flattened

and extended to give long, solid bearings in the planes of the horizontal skewback pins, 4 inches in diameter and 4 feet long, which are seated in pairs of upper and lower cast-steel bearing boxes supported on the transverse webs of the chords and the pedestals, respectively. The end of the chord is faced square with its axis, and the angle with the pin axis is made by beveling the upper casting, one end of which projects through a slot in the

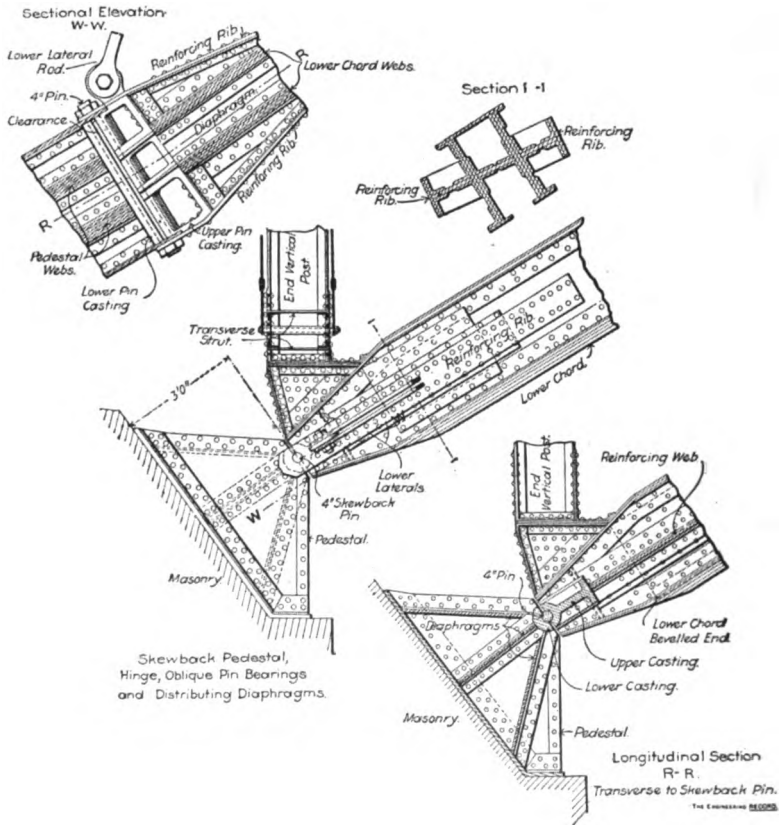

flange of the stiffening rib, and is bored to receive the end bottom lateral connection pin. The pedestal has three intersecting transverse webs in the plane of the skewback pin, which afford continuous bearing on their upper edges for the three sides of the cast-steel pin bearing, and connect the longitudinal side plates and reinforce intermediate webs. The pedestals thus have closed triangular cross-sections and bent base plates with two bearing surfaces, one 6 feet square, normal to the lower chord axis, and a

horizontal one 6 feet by 13 inches, which prevents the possibility of slipping down. The pedestals are bedded with rust joints on single granite cap stones 2 feet thick and have piers of ashlar masonry with concrete footings in pits sunk at an angle 12 or 15 feet into the solid shale ledge to be beyond the possibility of injury from weathering.

The trusses are connected by 35-foot floor beams, with tapered cantilever ends, which have their inclined lower flanges seated on the top chords of the arch trusses. There are horizontal top, bottom and intermediate transverse struts with riveted

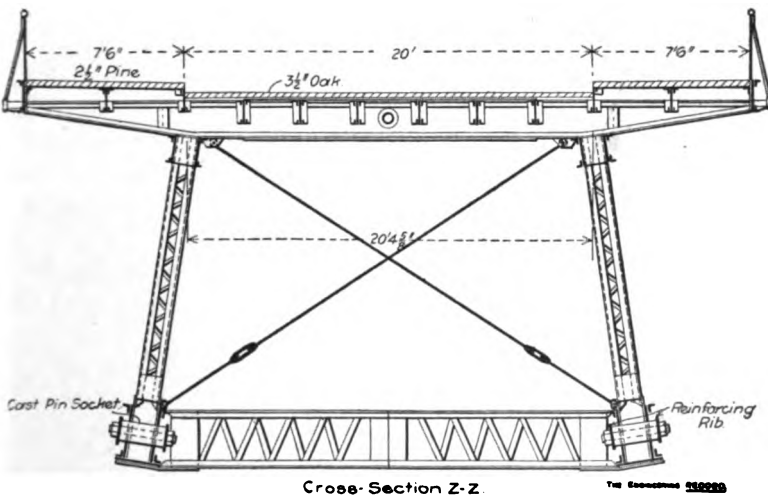

connections, and there are pin-connected diagonal rods in the vertical transverse planes, in the planes of the longitudinal struts and in the planes of the top and bottom chords. The crown pin rises and falls about 8 inches with temperature variations. The span weighs over 600 tons. It was designed to be erected by the cantilever method, but was finally assembled on trestle falsework, which was remarkable for its very heavy construction, and had a wide middle opening spanned by combination trusses to give a free water way. The erection was commenced in the fall and was discontinued through the severe winter weather, when the structure was drenched by spray from the falls, which enveloped it in a thick coating of ice.

## CHAPTER VI.

### THE RIO GRANDE AND LAKE STREET BRIDGES. SPANS 449 AND 456 FEET.

The Pacific Railway, of Costa Rica, crosses the Rio Grande river on a bridge about 685 feet long, which carries a  $3\frac{1}{2}$  foot gauge single track at a height of about 340 feet above the water. It has two lines of riveted deck trusses, which were described in "The Engineering Record" of October 25, and November 8, 1902, from which this account is reprinted.

It has a two-hinge spandrel braced arch span, with eighteen 24 foot 10-inch panels, making a span of 448 feet  $8\frac{1}{4}$  inches center to center of skewback pins, two cantilever spans, each with two 23-foot  $7\frac{1}{2}$ -inch panels, and two 70-foot  $10\frac{1}{2}$ -inch suspended shore spans, making a total length between end pins at the abutments of 684 feet  $11\frac{1}{4}$  inches.

The bridge is designed under Cooper's Specification for a live load of 2800 pounds per linear foot of span, and a dead load of 3000 pounds per foot of span. The top lateral system is proportioned to resist a stationary wind load of 150 pounds per foot of bridge. The moving wind load is assumed to be transmitted through the sway bracing into the bottom lateral system, so that this latter is proportioned for a stationary wind load of 150 pounds per linear foot of bridge, and a moving wind load of 300 pounds per foot of bridge. The three panels at each end were formed into supported spans to prevent the possibility of any hammering at the abutments.

The braced arch was originally figured in strict accordance with the method given in Professor Green's book on arches, using the general formula first presented by Professor Clerk Maxwell. On account of a change in the distances between piers the arch had to be refigured and a modified method was used which had in the meantime been developed by Mr. Cooper. The modification consisted in developing the formula for H for two symmetrical panels and summarizing them, thus obtaining a very simple formula by which formulæ could be immediately written for all the remaining panels. The modified formula suggested economic proportions of depth to length of span and saved a great amount

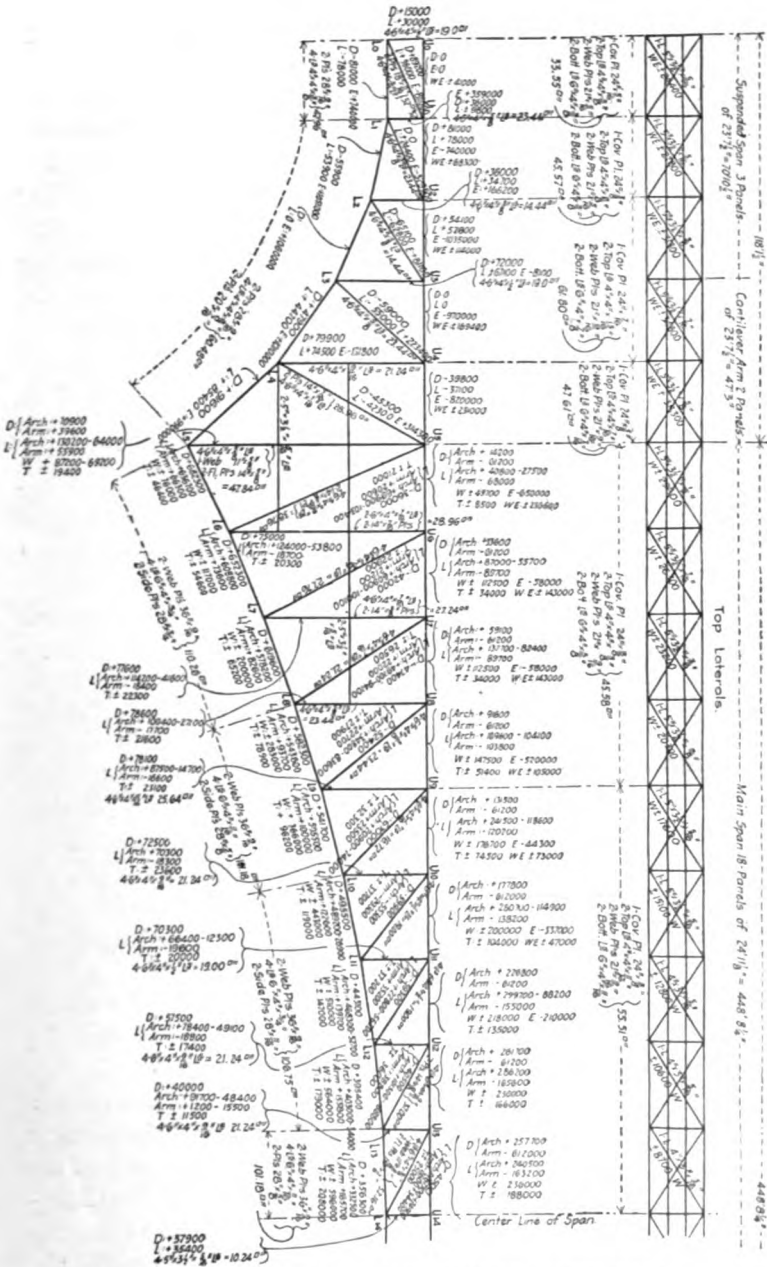

STRAIN SHEET OF RIO GRANDE BRIDGE, COSTA RICA.



of labor in computations. As no greater range of temperature variations occurs in Costa Rica the temperature stresses were calculated for a difference of only 70 degrees, but even this amount made them form a very considerable percentage of the total stresses.

The design of this bridge differs in some respects from that usually adopted for arches of this type. The most radical difference was in the character and shape of the skewback shoes and their masonry seats. They are made entirely of riveted steel instead of being cast as usual, and have the pin bearings thoroughly braced by solid transverse diaphragms which also serve to distribute the load over a widely extended base plate. The shoes were set in the planes of the trusses and symmetrical with them, instead of being set as usual in vertical planes, thus permitting the 15-inch pins to be at right angles to the planes of the trusses. The base plates were made in two planes, one normal to the pressure from the completed arch, and the other horizontal to receive vertical erection stress and to improve the stability of the shoe on the masonry which was built with a beveled seat to correspond with the inclined base.

The total weight of the superstructure was 932½ tons, and although it was built in the shops in one month the work was so accurately done and carefully inspected that no errors whatever were discovered in the field and it was assembled there without difficulty. This accuracy was secured by the use of special standards of measurement for the shops and for the field work, and by the greatest care in laying out the masonry and locating the shoes and truss centers. The principal points were determined by many repetitions of transit and level lines which were conducted on both sides of the canon, and tied together by triangulation, but which could not have the main span directly measured until after its erection was nearly complete.

At the bridge site the almost vertical banks of the canon are of weathered shale which was excavated to sound rock for the foundations of the skewback piers and abutments. On one side the slope between the pier and the abutment was steeper than that of the lower chord of the shore span and chases were cut in the surface wide enough to receive the lower part of the trusses and give clearance for inspection, painting and free drainage of surface water past the piers to the canon. The main piers were made out of cut stone masonry on concrete footings, but the abutments were made entirely of concrete enclosing, near the

base, grillages of I-beams for anchorage platforms. These were about 8 feet below the tops of the reaction rods which had screw bearings on top of the end floorbeams and were proportioned for a maximum tension of 280,000 pounds per truss, erection stress. In order to diminish this stress and reduce the great friction on the adjustment nuts when the center panel was connected the shore arms were heavily counterweighted and, the projecting ends of the semi-trusses being kept high during erection, were easily lowered to position at the center panel by slacking off the eight nuts on each end floorbeam.

Two steel tapes were purchased in the United States, sent to Washington and standardized by the United States Government, corrected for every ten degrees of variation in temperature, and were furnished with spring tension arrangements so that exact measurements could be made under the same tension. One of these tapes was sent to Costa Rica to be used as the standard in laying out the work, the other was retained in the United States and was used in the shops as a standard.

The work of erection in the field was carried on under great

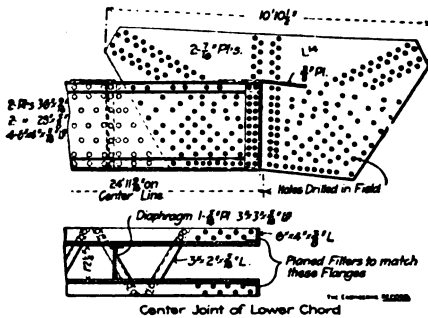

difficulty. All of the steel for one-half of the bridge had to be transported across the valley by cableway. The crudest kind of false work was used to save the expense of sending down lumber for the erection of the shore spans.

In order to allow a certain amount of leeway, to make up for any possible small errors in the placing of the shoes, the center panel members were made somewhat shorter than the calculated length, the holes in one side of the center gussets and splice plates left blank, to be drilled in the field after all parts had come to a full bearing, and a number of planed shimming plates were shipped to be used as needed.

As a further safeguard, the center chord sections were held

at the shop until the arms came sufficiently close together to allow of direct exact measurements, and thus correct any errors in that shop before shipment. It was, however, found that no corrections of any kind were necessary, and the works were telegraphed to ship the center sections exactly as designed, thus demonstrating the great accuracy obtained in the shop and in the field in the execution of this work.

During erection, the shore arms were bolted up solid to form continuous trusses so that the center arch could be erected from each abutment with only vertical anchorages, the top chords being designed to carry the entire tension from erection loads. After erection, the splice plates were removed from the bottom chord panels at the ends of the supported spans. The top panels were left solidly riveted up, as it is not thought serious to allow a slight bending in the comparatively shallow chord under partial loading, and a much more rigid structure is obtained by not interrupting the top lateral system at this point.

Theoretically the superstructure consists of a pair of spandrel braced arch trusses continued beyond the skewback piers to form cantilever arms  $47\frac{1}{4}$  feet long which support the river ends of the two approach spans and reduce their lengths from 118 feet  $1\frac{1}{2}$  inches to 70 feet  $10\frac{1}{2}$  inches. For the practical reasons already stated the top chord is a continuous riveted member 684 feet  $11\frac{1}{4}$  inches long between centers of abutment pins, and is designed to resist maximum tension and compression stresses. The cantilever arms are two panels long, and at their ends the bottom chords are spliced to those of the shore spans with bolts in slotted holes for longitudinal expansion. Except for a camber of 3 inches in the center the top chord is horizontal and the bottom chord changes inclination at every panel point, conforming to the chords of segments of a parabolic arc of 55.924 feet rise and 448 feet  $8\frac{1}{4}$  inches chord. The lower chord, from the skewback to the abutment, corresponds to the chords of segments of one-half a parabola with a rise of 58.14 feet and a chord of 236 feet 3 inches.

The arch trusses are battered 1:6 and are 40 feet apart on centers of shoes and 16 feet apart on centers of top chords. They have, as shown in the strain sheet diagram, vertical posts and single panel tension diagonals arranged like the web members of a Pratt truss, and having the same arrangement continued through the cantilever arms and shore spans so as to present a similar though unsymmetrical appearance, and resemble semi-arch trusses balancing the main arch thrusts. The track is car-

ried on two lines of stringers just below the top chord level, and the trusses are braced together with top and bottom laterals and bracing in the vertical transverse planes through all panel points.

The top lateral system consists of single 5 x 3½-inch angle horizontal transverse struts and X-brace angles field-riveted

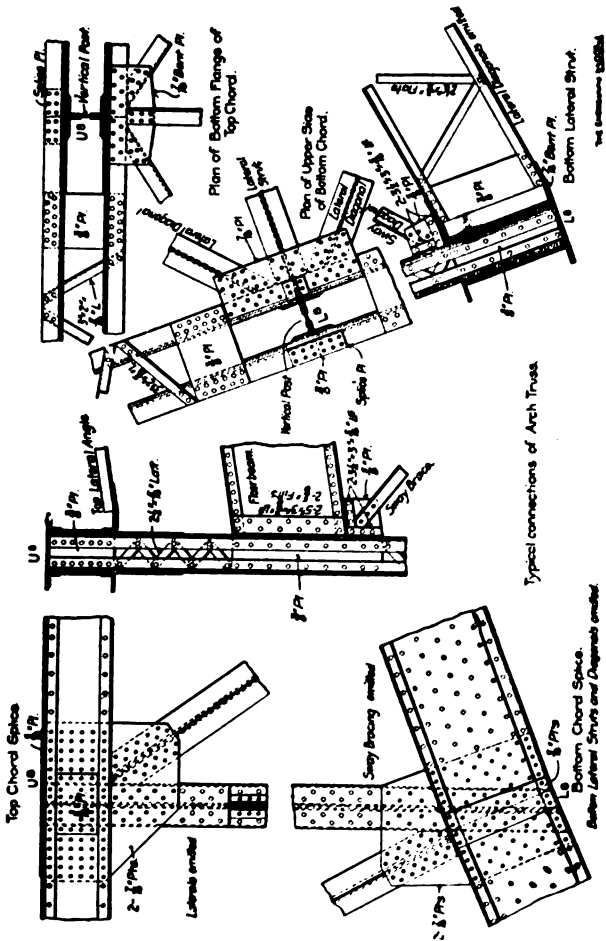

to connection plates on the lower inside flanges of the top chords and to the top flanges of the stringers. The bottom lateral system consists of horizontal transverse struts and X-braces in the planes of the bottom chord. All of these members are I-shaped struts made of two pairs of angles latticed, and are of equal depth with the bottom chord of the arch truss and field riveted to it with

bent connection plates across the top and bottom flanges. Between the bottom transverse struts and the floorbeams there are in each panel, from one to three panels of X-bracing of single angles which are all 4 x 3 x 5-16-inch except at the skewback piers, where they are 6 x 4-inch. Where there are two or more panels of X-bracing there are intermediate horizontal struts 18 inches deep with rectangular cross sections made with four 4 x 3 x 5-16-angles, latticed. Panel U6 L6 is like U5 L5, panels U4 L4 and U8 L8 are like U7 L7 and panels U2 L2, U3 L3, U10 L10, U11 L11, U12 L12, and U13 L13 are like U9 L9.

The top chord is made in single panel sections with milled ends abutting on the center lines of the vertical posts and spliced with top and bottom flange cover plates, outside web plates and inside gusset plates which receive the vertical and diagonal posts as shown in the detail at U6. All splices were assembled, fitted and reamed in the shops, all splice plates were shipped loose and all their rivets were driven in the field. The bottom chords are also made in single panel lengths, similarly spliced, but they have no cover plates. The webs are connected by vertical transverse diaphragm plates near each end and the flanges are latticed by zig-zag 3 x 2½-inch angles.

At the center joint only, there are vertical angles riveted to the ends of the webs of both sections, and these were connected by rivets through their outstanding flanges after the two chord pieces were assembled. Here, too, half the holes in the gusset plates were drilled in the field by pneumatic tools so as to be certain to match the corresponding holes in the chord pieces which were drilled in the shops. At bottom chord panel points L3 the gusset and splice plates were all field-riveted to the chord section nearest the skewback, and bolted, through slotted holes, to the other chord section so as to allow longitudinal and prevent transverse motion as shown in the detail drawing.

At the abutments shoes are riveted to the under sides of the lower chords and receive the upper pins of short vertical rocker posts which have lower pins in ordinary pedestals bolted to the masonry as shown in the detail elevation at L0. The floorbeams are made with 45 x 5-16-inch web plates and 6 x 4 x ½-inch flange angles, and are divided into three nearly equal panels by two pairs of 3 x 3-inch vertical web stiffener angles. The ends of the floorbeams are beveled to correspond with the batter of the trusses and are riveted to the faces of the vertical posts with 40 rivets in four vertical rows at each connection. The stringers have

36 x 7-16-inch webs and 5 x 3½ x 7-16-inch flange angles, and are seated on the top flanges of the intermediate floorbeams to which they are riveted with two rivets at each end. They are

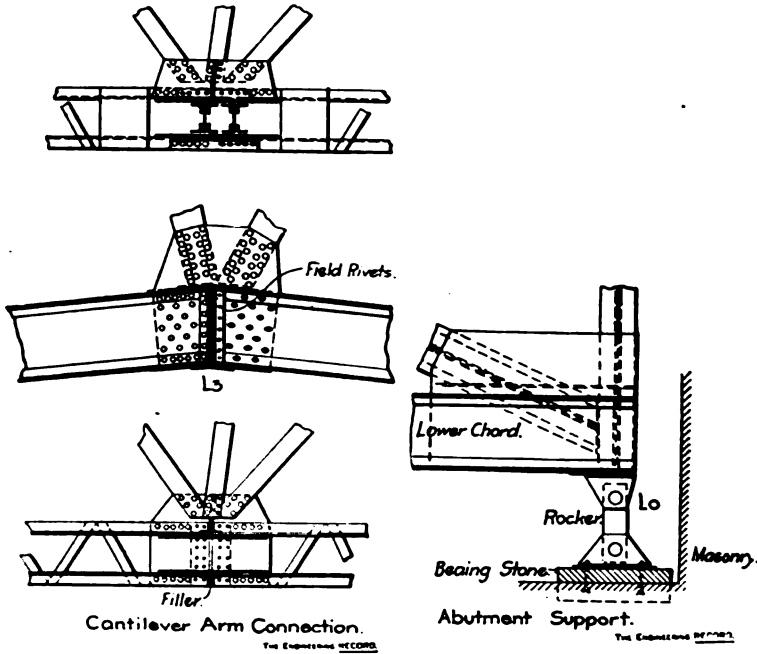

web connected to the end floorbeams, which are set correspondingly higher. The top lateral diagonal angles were cut to clear the bottom flanges of the stringers, and were riveted to them with short connection plates. Between the stringers one of the

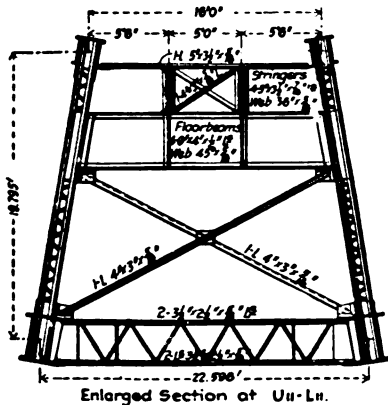

middle sections of the diagonals in each panel is continuous and the intersecting one is cut to clear it and spliced by a flat plate riveted to the bottom flanges of both angles.

All the web members of the arch truss have I-shaped cross sections made with four flange angles, which, except for Uo Lo and U<sub>13</sub> L<sub>14</sub> have latticed webs. These two members have solid plate webs and solid cover plates riveted to the flanges. The longest members are made in two or three sections each, spliced with web and flange cover plates, the latter being extended for connection with the horizontal longitudinal struts. The rocker

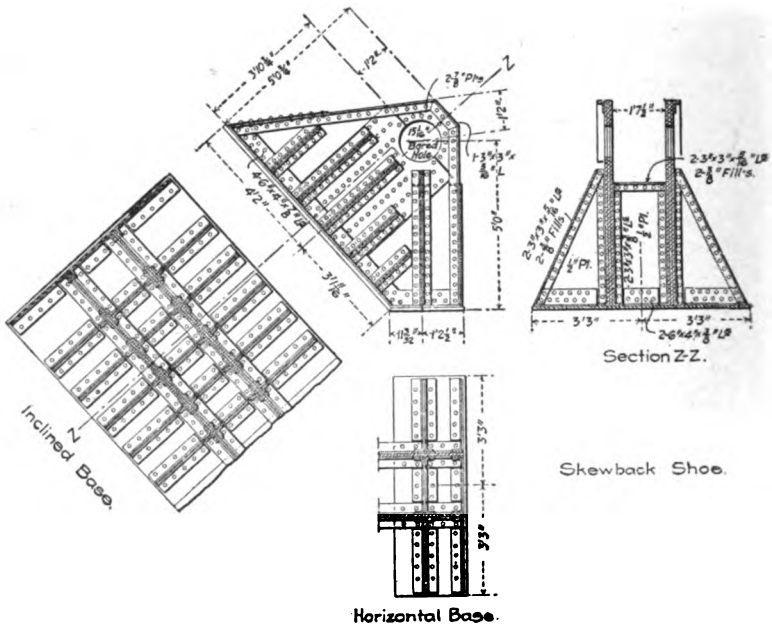

posts at the abutments are 18 7/8 inches long on centers, with rectangular closed cross section made with two 8-inch channels and two 11-inch cover plates. Both pins are horizontal, and the upper one engages a shoe with vertical web plates of unequal heights, riveted to a top plate which is set obliquely to engage the inclined surface of the bottom chord of the battered truss.

Material for the superstructure was shipped from New York direct to Port Limon, in three invoices, two by regular line boats and one by a chartered steamer. It was then shipped by rail to the site and unloaded by steam derricks in a storage yard on the east side of the canon. A cableway with a main cable about

2½ inches in diameter and 900 feet long was erected across the canon, and by it all the material for the west half of the bridge, which was painted red to distinguish it from that for the eastern half, which was painted white, was transferred to the opposite side in readiness for simultaneous erection. The 8-ton skewback shoes on the main piers were first set on mats ¾-inch thick, which were made of layers of felt soaked in hot coal tar. These covered the whole top of the masonry and were used to bed the base

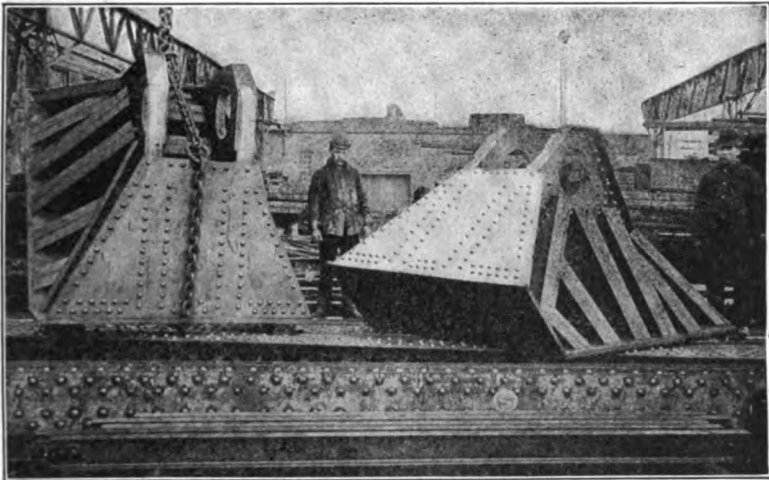

SKEWBACK PEDESTAL AT BRIDGE SHOP.

plates instead of grouting them, because of the difficulty of injecting the grout thoroughly under so large a base plate without vent holes for the escape of the air.

Between the piers and the abutments the trusses were erected in their required position on timber blocking by the use of the two overhead traveling derricks, which were designed for the cantilever erection of the arch trusses. The joints at L<sub>3</sub> were bolted tight, and all other joints were riveted permanently and the arch trusses were built out panel by panel until their increasing moment produced a slight uplift at the abutments. All blocking was then removed from under the shore trusses and the nuts on top of the vertical anchor bars were screwed down until the points U<sub>0</sub> were depressed about four inches below their final positions. The erection was continued to the center panel and the last sections of top chords were inserted several inches above their final positions. The shore ends of the trusses were



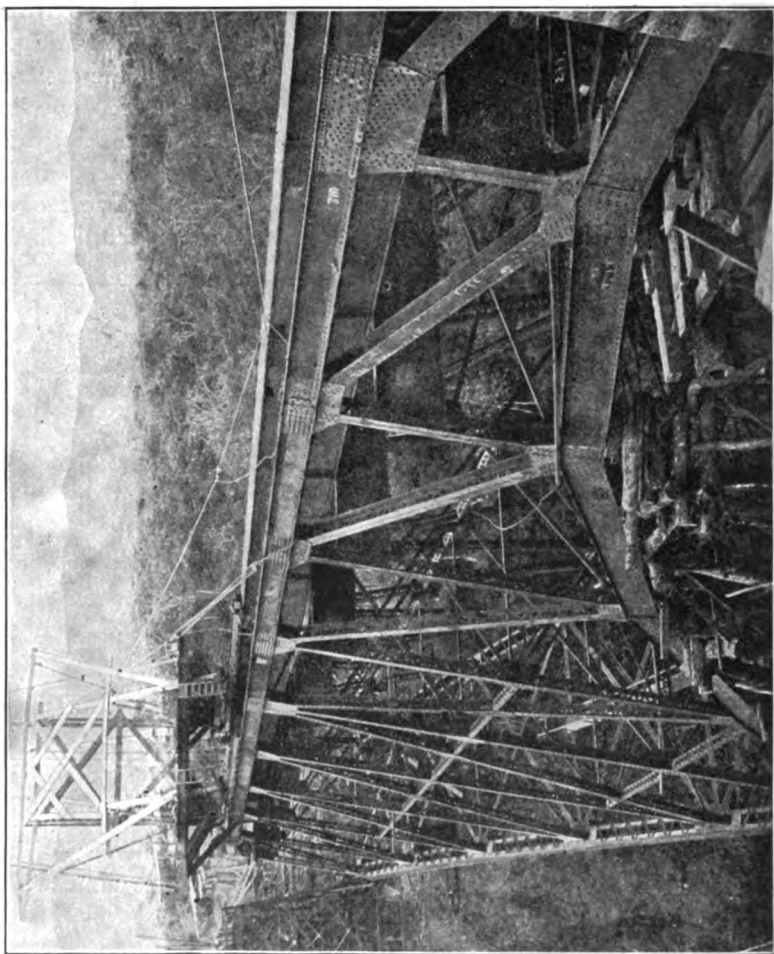

SUPPORT OF ANCHOR ARM ON FALSEWORK.

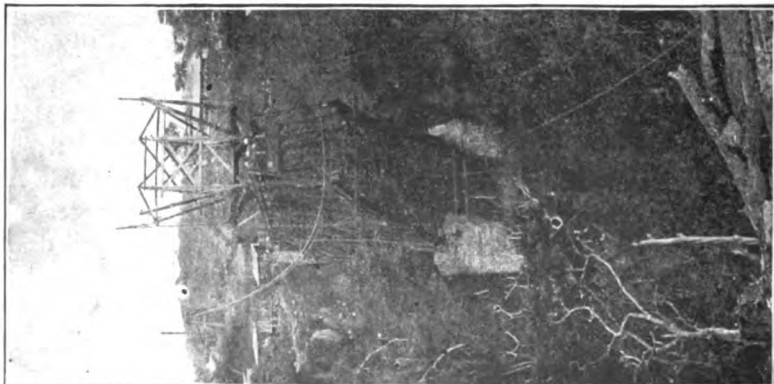

CANTILEVER ERECTION OF SEMI-ARCH

then loaded with several hundred tons of ballast so as to partly balance the moment of the overhanging arms and reduce the tension on the anchorage arms, and the nuts of the latter were slacked off, allowing the top chords to assume their required positions when the last joints took the calculated com-

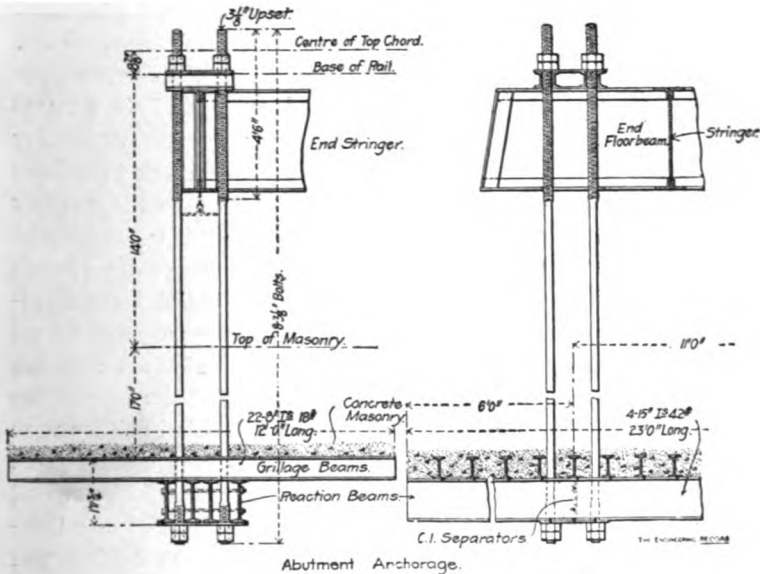

pression and the blank web splice plates were drilled and riveted, and the rivets were driven in the rest of the top chords and in the floor system where the holes had before been filled with bolts exclusively. The other field rivets, including those in the bottom chord splices, were driven as soon as possible after the joints were assembled, and nearly all of them were driven by pneumatic hammers operated by air at about 80 pounds pressure, delivered in steel pipes run to a compressor, which was driven by steam from a locomotive boiler.

The traveler had a horizontal platform which rolled on the top chords of the completed assembled structure and carried over the forward wheels a transverse bent with two vertical masts about 36 feet high and 16 feet apart. They were sway braced together with horizontal struts and two panels of diagonal rods, and had inclined stiff legs which were braced together like the masts, and had horizontal and vertical braces in vertical planes at their center points. At the foot of each mast there was pivoted

a 12 x 12-inch boom 50 feet long. A horizontal transverse strut 40 feet long was fastened to the masts 5 feet below their tops, and its extremities were braced to the tops of the masts and to the working platform, by inclined struts. This gave additional transverse stiffness to the traveler and afforded a connection for whip lines and light tackles outside the top chords for convenience in handling members in the inclined planes of the trusses. The working platform was elevated about 6 feet above the tops of the wheels, and its transverse floorbeams projected about 12 feet each side of the traveler sills, and were knee-braced to them inside and outside, thus affording clearance under the floor for small cars on the permanent bridge track to deliver material through the traveler under the floor to the derrick booms.

When in service the traveler was anchored to the top chords by chains around the sills, and the top chords, which were tightened by pairs of wedges, and the front wheels were blocked up clear of the rails. Temporary kneebraces were also set between the ends of the floorbeams and the top chords, and the tops of the masts were guyed to the top chords several panels back by wire ropes with adjusting tackles. The derrick booms were rigged with manilla rope tackles operated by one six-spool Lidgerwood hoisting engine on each traveler. The total weight of one traveler, engine and rigging was about 22 tons. The bridge was erected by fifty men in about three months, and, although only a dozen of the men were experienced bridge erectors sent out by the contractors, no casualties were reported.

The final calculations were made by a method derived from

$$\text{the formula } H = \frac{\sum S_v \times S_1 \times \frac{m}{\lambda}}{\sum S_v^2 \times \frac{m}{A}}$$

In which  $H$  = total horizontal thrust;  $S^{\circ}$  = total stress in a member from horizontal unit reaction only;  $S_1$  = total stress in a member from vertical unit reaction only;  $m$  = length of a member, and  $A$  = area of cross-section of a member. This formula was first presented by Professor Clerk Maxwell, as is used by Professor C. E. Greene for the determination of stresses in his text book on arches. For a long span this determination requires so many operations that it becomes very laborious, and in applying it to this case Mr. Theodore Cooper was convinced that it might be much simplified. A careful analysis demonstrated

the correctness of this belief, and by the application of the formula to two symmetrical panels, simple formulas were developed containing progressive factors which make it possible to write the formulas for any panel length and panel number after they have been developed for a given panel length and panel number.

The formulas were tabulated and applied, the computations made and the strain sheet prepared by Mr. Gunvald Aus and approved by Mr. Cooper. The development of the simplified formula and its application to this truss is clearly and concisely explained by Mr. Aus, as follows:

If in the truss shown in the figure, which is the simplest form of a spandrel arch, we assume a member A B of length  $m$  under a stress  $F$  to be shortened an amount  $dm$ , we know that the abutment  $o$  would have to move through a space  $ds$ , such motion being due to a rotation around panel point  $E$ , and, provided the motion is very small and no other members are strained, and the other abutment remain fixed, we know that

$$\frac{ds}{dm} = \frac{v}{r} \text{ or } \frac{y}{r} dm \dots (1)$$

From the theory of elasticity we further know that

$$dm = \frac{m}{E A} F \dots (2)$$

In which  $m$ , as already stated, is the length of AB;  $A$  the cross-section of the member, and  $E$  the elastic modulus.

If we now further assume the stress  $F$  to be due to vertical and horizontal reactions  $v$  and  $h$ , we find part of  $F$  due to  $v$  to be equal to  $v \frac{x}{r}$ , and the part due to  $h$  to be equal to  $h \frac{y}{r}$ , in

other words:  $F = v \frac{x}{r} + h \frac{y}{r}$ , and introducing this in equation (2) we get:  $dm = \left( v \frac{x}{r} + h \frac{y}{r} \right) \frac{m}{E A} \dots (3)$

If we introduce this value of  $dm$  in equation (1) we find:

$$ds = \left( v \frac{x}{r} + h \frac{y}{r} \right) \frac{y}{r} \times \frac{m}{E A} \dots (4)$$

Evidently the expressions  $\frac{x}{r}$  and  $\frac{y}{r}$  are the stresses due to a vertical and horizontal unit reaction, since such units would cause stresses  $= 1 \times \frac{x}{r}$  and  $1 \times \frac{y}{r}$ , and for convenience we

will call the former  $S_1$  and the latter  $S_0$ , or  $\frac{x}{r} = S_1$ ;  $\frac{y}{r} = S_0$ ; we can then write equation (4) in the form:

$$ds = (v s_1 + h S_0) S_0 \frac{m}{E a} \text{ or}$$

$$ds = (v S_1 S_0 + h S_0^2) \frac{m}{E a} \dots \dots \dots (5)$$

This equation holds good for any kind of truss, but applied to a

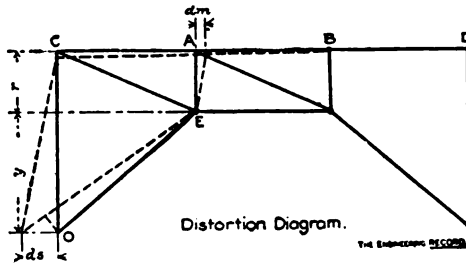

spandrel arch, where the abutments are fixed in a horizontal direction we know that  $ds = 0$ , and therefore get

$$h S_0^2 \frac{m}{E a} = v \times S_1 \times S_0 \frac{m}{E a}, \text{ or}$$

$$h = \frac{v S_1 S_0 \frac{m}{E a}}{S_0^2 \frac{m}{E a}}$$

That is to say, the stress F in a member AB produces a horizontal reaction expressed by this equation; or if we summarize the amounts of horizontal reaction produced by a stress F in each member of the truss to find the total horizontal reaction, we get:

$$H = \frac{\sum v S_1 S_0 \frac{m}{E a}}{\sum S_0^2 \frac{m}{E a}} \dots \dots \dots (6)$$

As soon as we have the H for any given loading, the calculation of the stresses in the members is, of course, perfectly simple, either by graphical diagrams or by the methods of moments.

Professor Greene's method is to make a diagram for the stresses in each member of the truss, under a panel load applied to each panel, putting the resulting stresses  $v S_1$  in the members

in a table, and to construct a diagram for a unit horizontal action with the resulting stresses  $S_0$  in another table.

By multiplying and squaring the  $h = \frac{v S_1 S_0}{S_0^2}$  is now found, neglecting the  $\frac{m}{E a}$  which has very little effect on the horizontal reaction.

By means of this approximately correct H, found by summarizing all of the individual h's, he then calculates the stresses F in the members and proportions them for this approximately correct stress. He then introduces the cross-sections so found and the lengths of the members in equation (5) and again calculates the H which is now very nearly correct, and from this H again calculates the stresses F and proportions the members for the corrected stresses.

As already stated, it was a very tedious and trying operation to graphically construct the 18 diagrams needed for the Rio Grande bridge, and so Mr. Cooper suggested doing the operation by writing the formulas for  $S_0$  and  $S_1$  for a load on any panel point for two symmetrical members of the bridge, and summarizing these formulas. The approximately correct  $h = \frac{v S_0 S_1}{S_0^2}$  could thus be written in very simple formula for each member, and

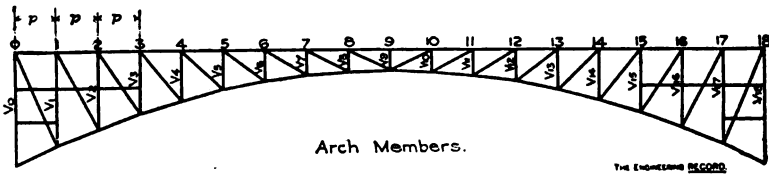

RIO GRANDE BRIDGE, COSTA RICA, 448-FOOT 8¼-INCH SPAN.

these formulas be very readily solved by logarithms or by Thatcher's Slide Rule. To make this method a little clearer, we

will write the formula:  $h = \frac{v S_0 S_1}{S_0^2}$  for the first and the last panels of the top chord of the Rio Grande bridge for a panel load  $w$  on the first panel point. For these points the formula can be written  $h = \frac{v S_1}{S_0}$ . We get for a load  $w$  on panel point

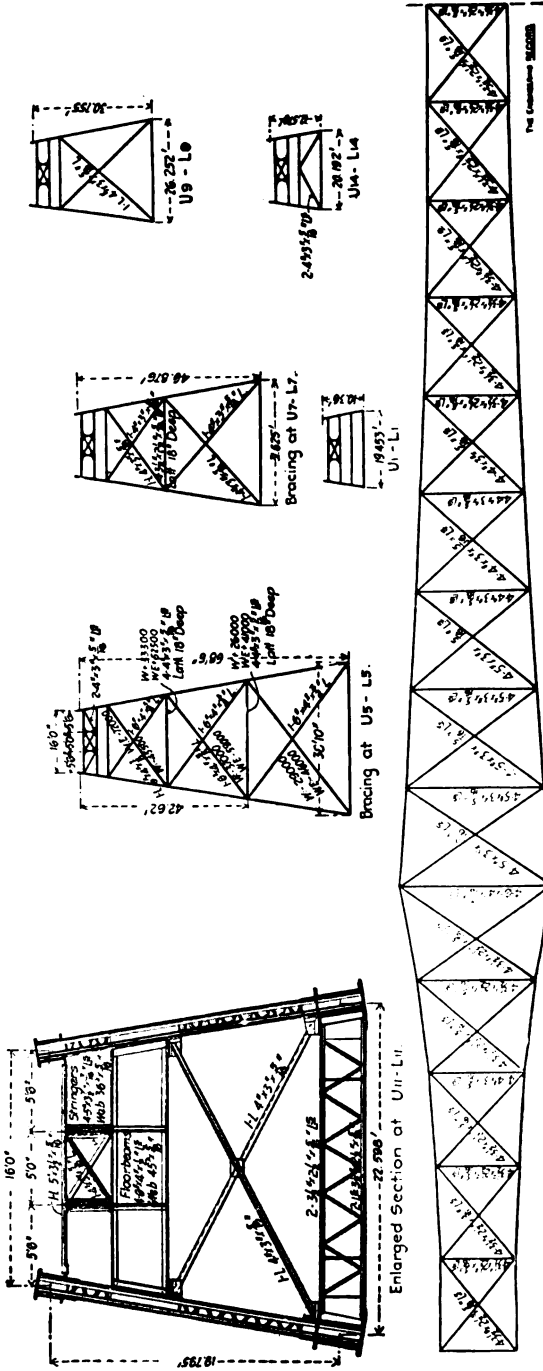

Strain Sheet and Material Diagram.

1, bearing in mind that the left reaction  $v$  is equal to  $\frac{1}{2} w$  and that the right reaction is equal to  $\frac{1}{2} w$ ,

for member 0 — 1,  $S_1 = w \frac{17}{18} \times \frac{P}{v_1}$ ,

for member 17 — 18,  $S_1 = w \frac{1}{18} \times \frac{P}{v_1}$ , and summarizing these

two we get  $w \frac{P}{v_1}$ .

We further get  $S_o$  for each panel =  $\frac{v_o - v_1}{v_1}$  and for the two panels =  $2 \frac{(v_o - v_1)}{v_1}$  and consequently

$$h = \frac{\frac{w P}{v_1}}{2 \frac{(v_o - v_1)}{v_1}} = \frac{w P}{2 (v_o - v_1)} \dots \dots \dots (1)$$

Exactly the same equation will be found for any other panels of the top chord for a panel load on (1) only. In exactly the same manner the formulas are written for all other loadings and for all other members of the truss. It will be found that it is only necessary to develop the formulas for one or two members for each loading, after which the others can be written out mechanically, as they have an easily established relation to one another.

The wrought iron highway deck bridge across the Mississippi River at Lake Street, Minneapolis, includes two 456-foot channel spans about 125 feet high above the water. Each span has two three-hinge spandrel-braced arch trusses, of about 95 feet rise, in vertical planes 19 feet apart. They are connected by lateral systems in the top and bottom chord planes, and by from one to three panels of sway bracing in the planes of the vertical posts. The top and bottom chords are made of pairs of built channels latticed; in the top chord the channel flanges are turned inwards, and in the bottom chords they are turned outwards, but they are vertical in both cases. The principal web members of the trusses are zig-zag diagonals at different angles, which reach over one or two panels and are pin-connected to the chords. Vertical members from the ends of these web members and from the middles of the two-panel members divide the trusses into twenty-four panels of uniform length. The verticals and diagonals have I-shaped cross sections made with pairs of angles riveted together back to back and latticed, and all their connections are field-riveted to web-connection plates, except



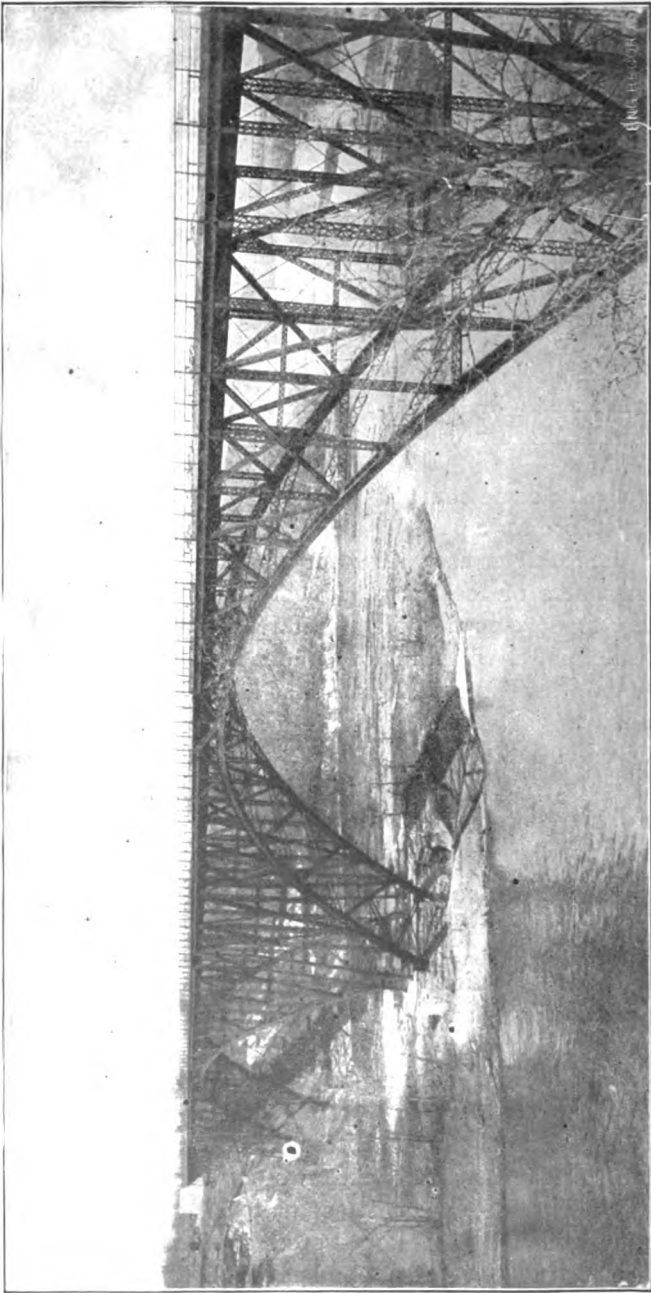

LAKE STREET HIGHWAY BRIDGE, MINNEAPOLIS, 456-FOOT SPAN.

at the ends of the main diagonals. The sub-verticals are connected to the top chords with 3-inch pins and are field-riveted to the top flanges of the bottom chords with bent plates. Special care was taken to make the top chords discontinuous at the

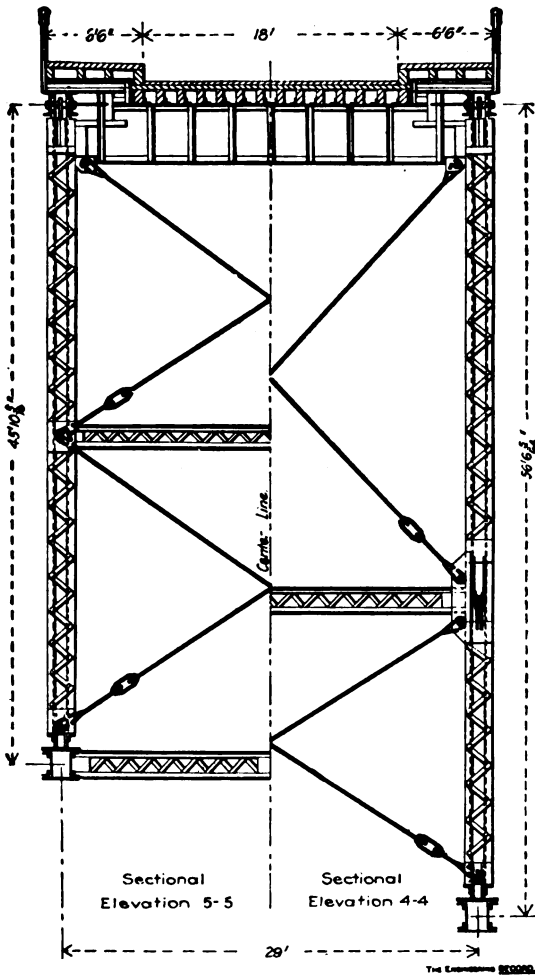

Typical Half Cross-Sections.

center and ends of the spans, and they were inclined downwards to bearings on the lower chord pins at the crown hinge. The lower chords have clearance between their half-hole bearings on the crown hinge pin, but the semi-trusses are locked to-

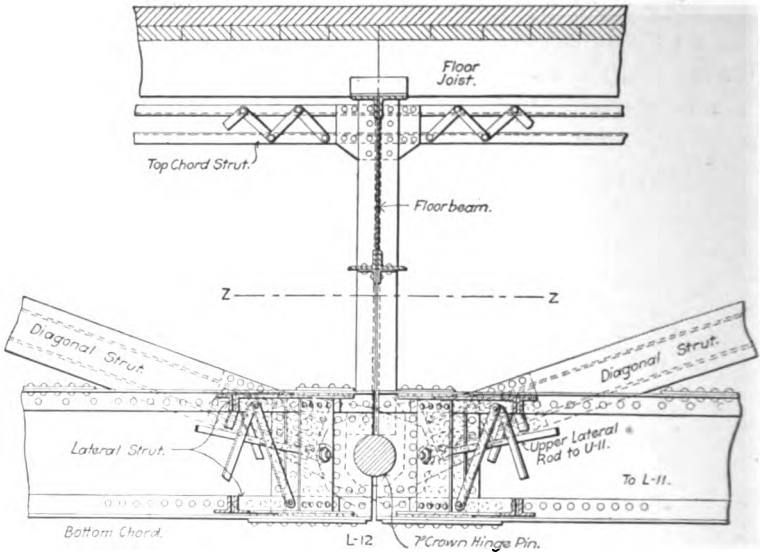

Elevation.

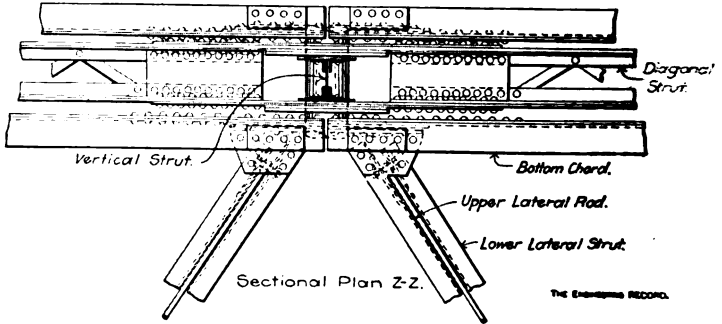

Connections at Crown.

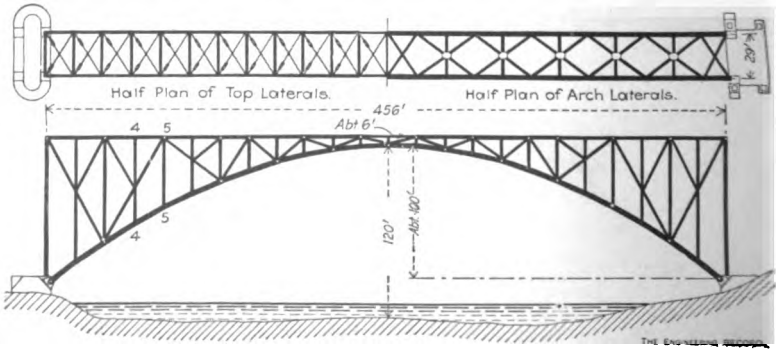

LAKE STREET HIGHWAY BRIDGE.

gether there by the full holes in the jaw plates on the ends of the vertical and diagonal members.

The top laterals are square rods with loop eyes connected to vertical pins through tie plates in the top chords. At the center point of the span the ends of the diagonals are connected to horizontal pins through the double vertical end plates of the lower lateral diagonal struts, between which the rods pass. The lower laterals are I-shaped struts field-riveted to horizontal connection plates on the inner flanges of the bottom chords. They are cut to clear at intersections where they are riveted to flange connection plates on the continuous transverse struts. Near the center of the span the top lateral diagonal rods have screw ends with their nuts bearing on the ends of pairs of horizontal angles, between which they pass and which are riveted to the top chord flange tie plates. The sway brace diagonal rods have bent eyes engaging the bottom chord pins, and straight eyes engaging longitudinal pins through the transverse struts and through pairs of angle clips riveted to the bottom flanges of the floorbeams. The bridge was assembled on pile and trestle falsework erected from the ice, and was remarkable for the manner of assembling and connecting up the arch trusses from one skewback continuously to the other instead of from both skewbacks to the crown simultaneously. This method was successful, but involved special diagonal braces in the falsework.

## CHAPTER VII.

### NIAGARA AND VIAUR BRIDGES. SPANS 550 AND 721 FEET.

The Niagara Railway Arch across the Niagara River, at Niagara Falls, replaces the famous railroad suspension bridge

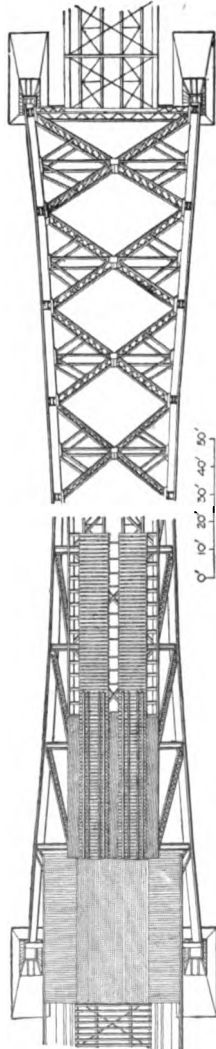
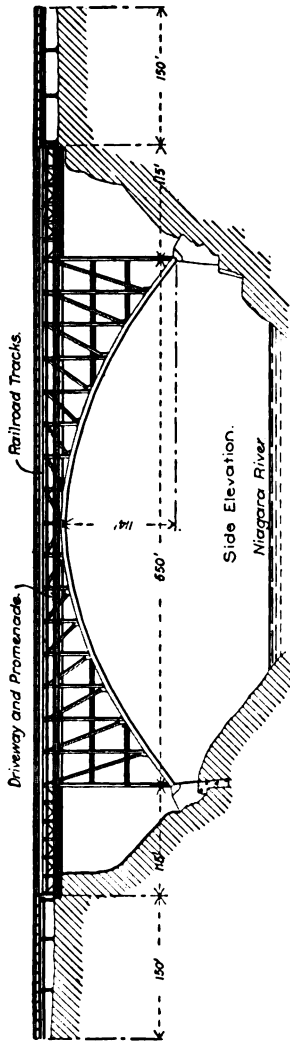

Part Top Plan.  
DOUBLE-TRACK RAILROAD SPAN ACROSS NIAGARA RIVER.  
Part Plan of Bottom Lateral.  
The Lateral Load.

built on the same site by John A. Roebling in 1855, which had a center span of 821 feet and a height of 225 feet above the river. It was described in "The Engineering Record" of April 24, 1897, and in the "Transactions" of the American Society Civil Engineers, Vol. 40, page 125. The new bridge has two spandrel-

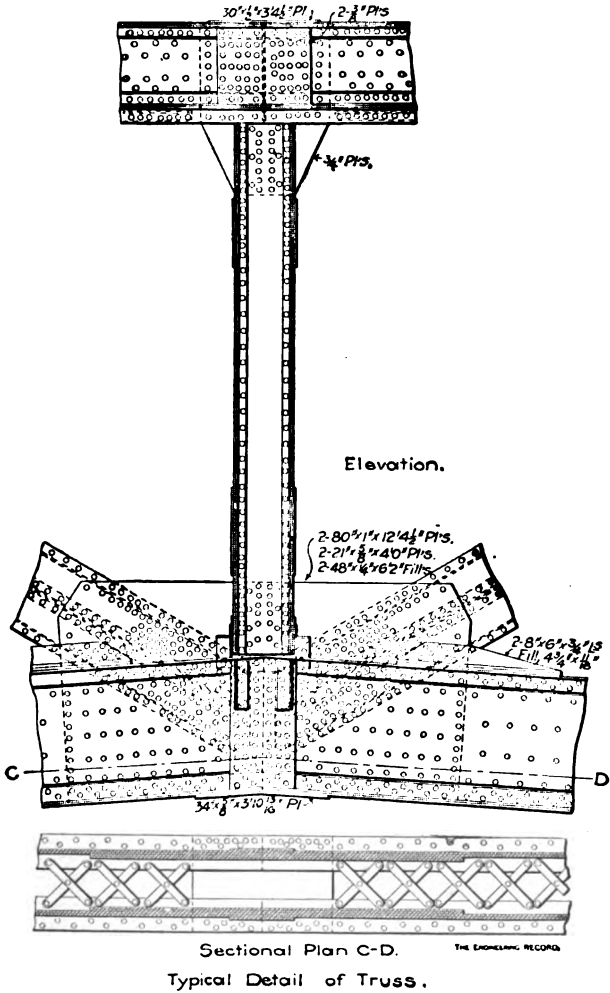

braced two-hinged steel arch trusses, with horizontal top chords, and bottom chords of straight sections, one panel long, which are chords of a parabolic curve. The span is 550 feet, the rise 114 feet, and the depth of truss is 20 feet at the crown and 134 feet at the ends. The trusses are 56 feet  $9\frac{1}{2}$  inches apart on centers

at the skewbacks, and are battered 1:10 so that the top chords are only 30 feet apart.

All truss members are compression pieces with rectangular cross sections, built up of plates and angles and all connections are made with double gusset plates, except at the skewback hinges. There are stiff lateral braces in the planes of the top and bottom chords, sway braces in transverse vertical planes at panel points, and longitudinal horizontal struts from the haunches to the end posts to stiffen the longest web members. The main floor beams are 54-inch plate girders seated on the tops of the

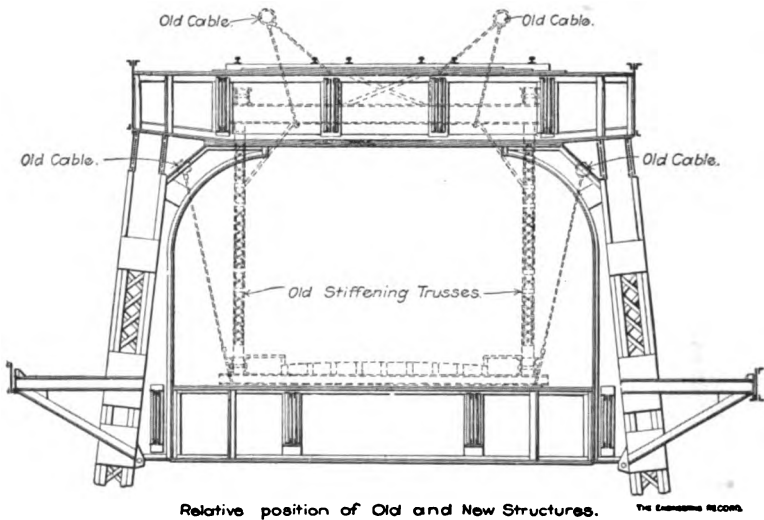

vertical posts, and carrying two railroad tracks. At each end of each beam, there is a curved knee brace with a solid web plate and flange angles, which is riveted to the vertical post and extends to the bottom flange of the roadway floor beam. Each pair of braces forms a sort of portal and gives great stiffness to the arch trusses, as well as affording a vertical flange connection for the ends of the lower floor beams, which are carried on the battered posts. The highway floor beams are 54-inch plate girders, and carry a 25½-foot roadway about 15 feet in the clear below the upper floor beams. There is an electric car track in the middle, and, on each side, an 11-foot sidewalk, which is partly cantilevered beyond the truss.

The ends of the lower chords have flat base plates bolted to the double beveled upper faces of steel castings with convex lower





were designed for a uniform load of 2200 pounds per linear inch and were adopted to avoid pins of excessive diameter, the assumption being that they would be equivalent to ball bearings. The tops of the rollers are almost in contact and there are 5/16-inch square bars riveted between their lower edges to restrict the movement should there be any tendency for overturning, although the actual movement has been observed to be very slight. During erection they were held in correct radial position by temporary end stops. The cast steel skewback pedestals weigh 35

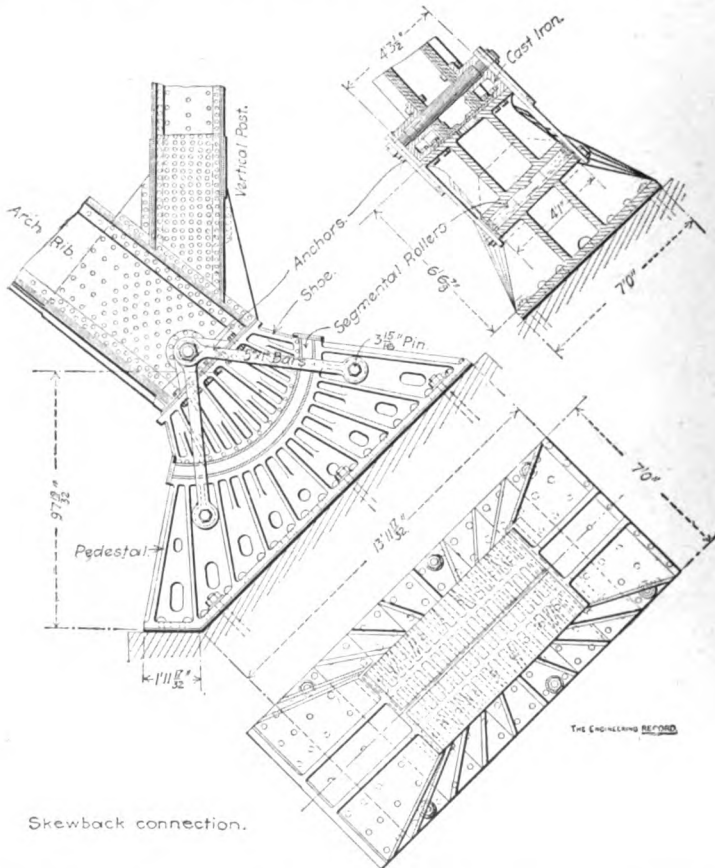

Skewback connection.

tons each and are seated on very large separate piers of dimension limestone with granite copings normal to the line of pressure, except for a short horizontal portion at the lower end which afforded a stop to take the vertical component of the thrust and prevent any possibility of displacement during erection. On the

New York shore the piers are seated directly on the solid rock ledge, but on the Canada shore they have concrete footings.

The maximum masonry loads per square inch are, on top of coping 339 pounds, under coping 300 pounds and on concrete

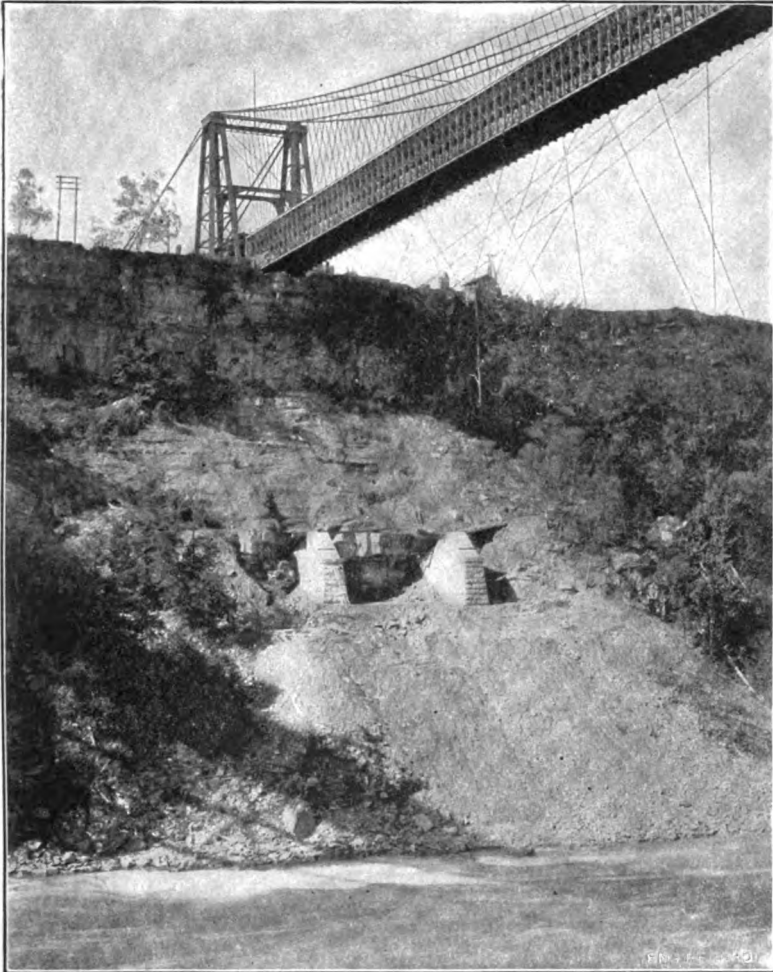

**POSITION OF ARCH PIERS IN PLACE OF OLD SUSPENSION BRIDGE.**

113 pounds. The pedestals are bedded on the copings with a thoroughly rammed rust joint made 1:32 by weight of sal ammoniac and cast-iron filings. The trusses were designed for a live load on each track, of two locomotives each having 40,000 pounds on each of four axles and followed by a train load of

3500 pounds per linear foot. The stresses were calculated by the method in chapter XII. of Professor Greene's text-book on arches, and then the sections were increased to be a mean between these requirements and those assuming that there was a center hinge, thus providing for inaccuracy of adjustment. The camber

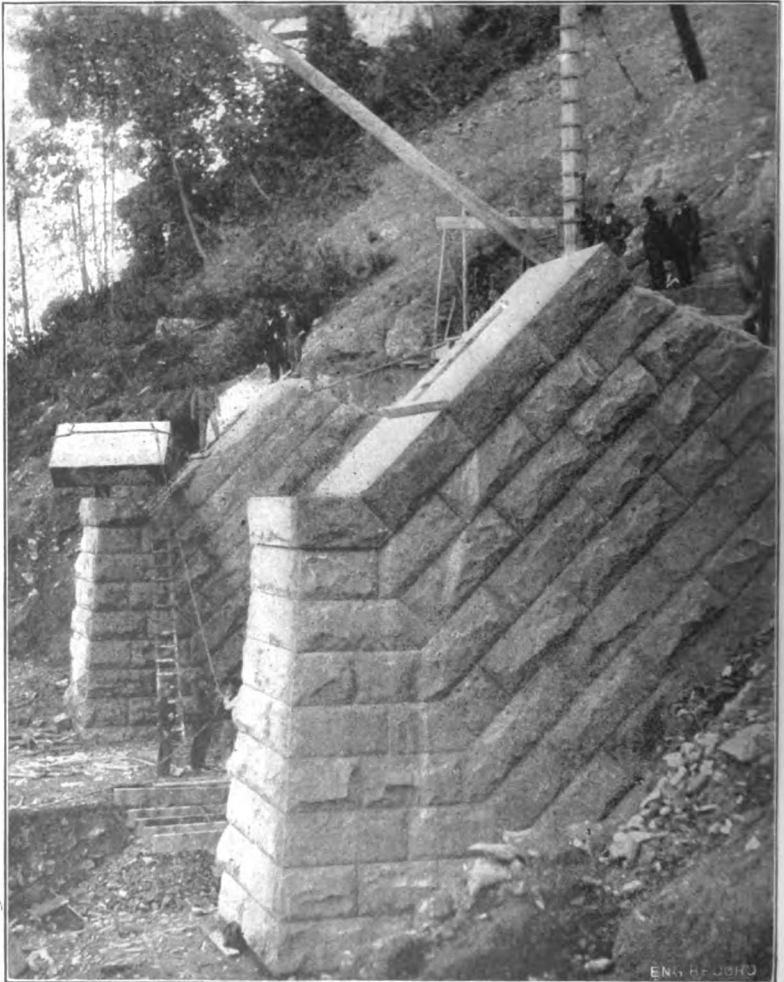

PIERS, CANADIAN SIDE.

was designed to be 8 inches at 60 degrees Fahrenheit, and has been observed to range from 7 inches in winter to 10 inches in summer. The calculated deflection under a moving load of 10,000 pounds per linear foot was  $1 \frac{15}{16}$  inches, and the ob-

served deflection under a 6500-pound test load was 13/16 inch. Vibrations due to a train at a speed of 20 miles per hour are scarcely noticeable and the structure is believed to be more rigid than any other bridge of equal span. The total weight of the bridge, including a 115-foot deck truss span at each end, is about 7,200,000 pounds.

The skewback piers are located half way between the feet of the cliffs and the water lines, on very steep rocky slopes where framed trestle bents were set and braced together in alternate panels to make falsework on which the approach spans were

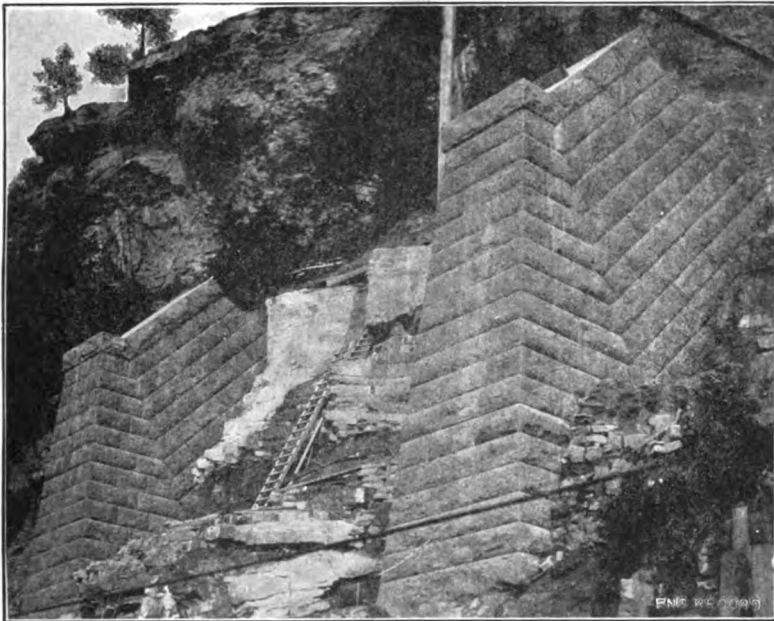

PIERS, AMERICAN SIDE.

erected, operations for them and all other parts of the erection being carried on simultaneously in duplicate on both sides of the river. On each shore a two-bent steel strident traveler was erected on the river ends of the falsework beyond the steel towers of the old suspension bridge, which still maintained traffic at the same level and alignment as was to be provided for in the new span. The travelers cleared the old cables and stiffening trusses and had, on the forward corners, two 40-foot, 40-ton booms which commanded one panel of the truss in advance.

The travelers set the 35-ton skewback castings and assem-

bled all the members of the first panels which were temporarily supported on falsework bents under the lower chords. After the end panels were completed the skewbacks received the vertical loads and thrusts and the tendency to rotate around them was resisted by the erection anchorages connected to the ends of the

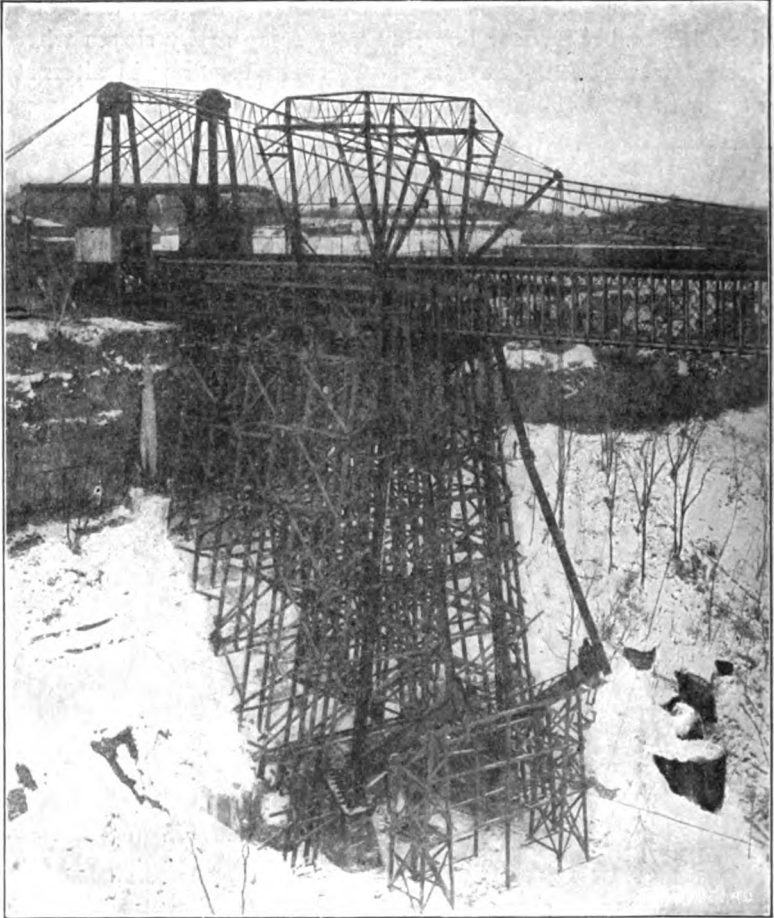

APPROACH FALSEWORK AND FIRST PANEL OF MAIN SPAN,  
ON CANADIAN SIDE.

top chords. These had pin-connected chains, with a minimum area of 80 square inches, which extended horizontally nearly 300 feet from the shore ends of the top chords, were deflected vertically over radial struts, and had bottom pins engaging reaction

beams solidly concreted in the enlarged bottoms of narrow vertical shafts in the solid rock.

Commencing at the river end the chains were made with three panels of eyebars, six panels of the temporarily assembled riveted top chords of the deck approach spans, two 26-foot panels

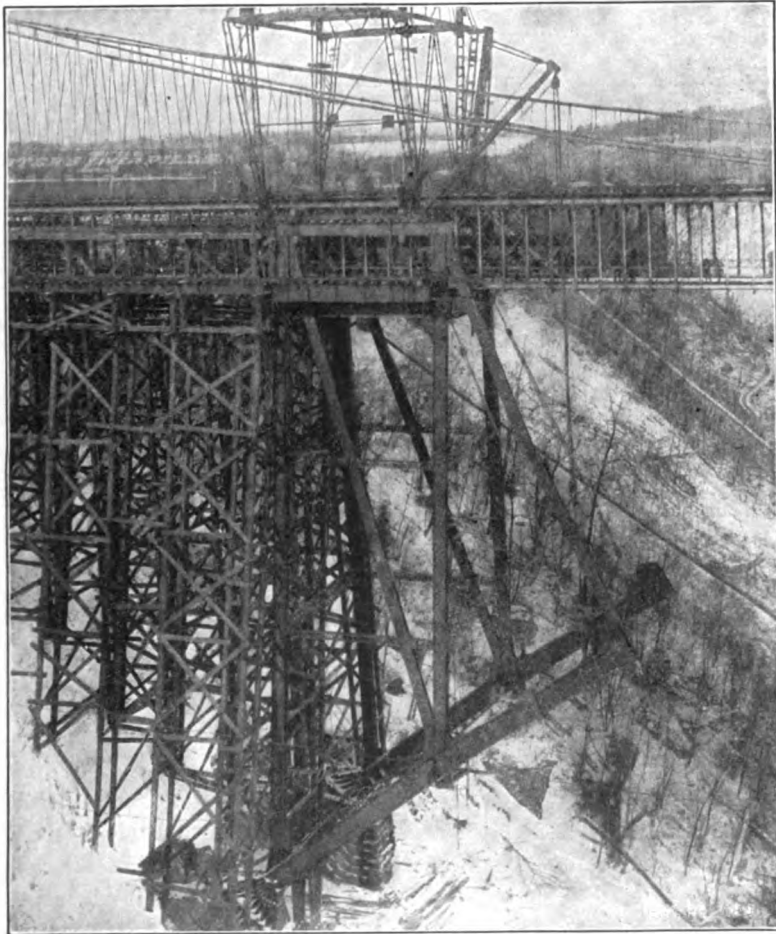

ERECTING SECOND PANEL OF ARCH TRUSS AS A CANTILEVER.

of adjustment eyebars, four short panels of square-ended un-forged deflection bars and one panel of vertical eyebars. The bars in each pair of adjustment panels were arranged in the form of an oblique parallelogram having for the short diagonal a vertical screw  $9\frac{1}{2}$  inches in diameter and 17 feet long. The

ends of the screw had right and left handed threads engaging the yokes to which the eyebars were pin connected, and the lower ends had also capstan heads by which they were turned to lengthen or shorten the diagonal of the parallelogram and correspondingly vary the length of the anchor chain. As its shore end was fixed this necessarily gave a horizontal movement to the river end which was attached to the top of the end vertical post

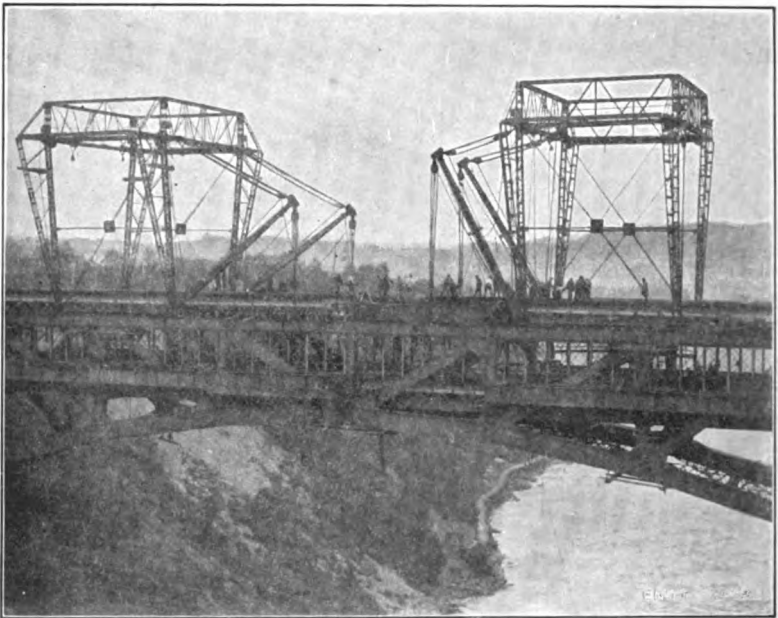

STEEL TRAVELERS COMPLETING CENTER PANEL.

of the arch truss and, revolving it through an arc around the skewback pin, raised or lowered the river end of the semi-truss by the combined action of the screw and toggle.

As the travelers erected the panels of the trusses in advance, cantilever-wise, they successively moved forward on the top chords and received the truss members from cars on tracks made with the railroad stringers temporarily supported on the sidewalk brackets and afterward permanently assembled between the same floorbeams. The travelers were made with four double posts, each of which was much wider at the top than at the bottom, so as to secure transverse rigidity without diminishing the train clearance by kneebracing. The tops of the posts were connected

by light, deep, longitudinal and transverse lattice-girders, and the longitudinal faces of the travelers were X-braced by screw rods.

Owing to the absence of crown hinges it was necessary that the location and alignment of the skewback pins be very accurate, and so their centers were plumbed down to the piers from the old suspension bridge and lined in by a transit on shore. When the center panels of the two arch trusses had been erected there was an opening of 8 inches between the ends of the top chords, due to the upward inclination which had been provided for erec-

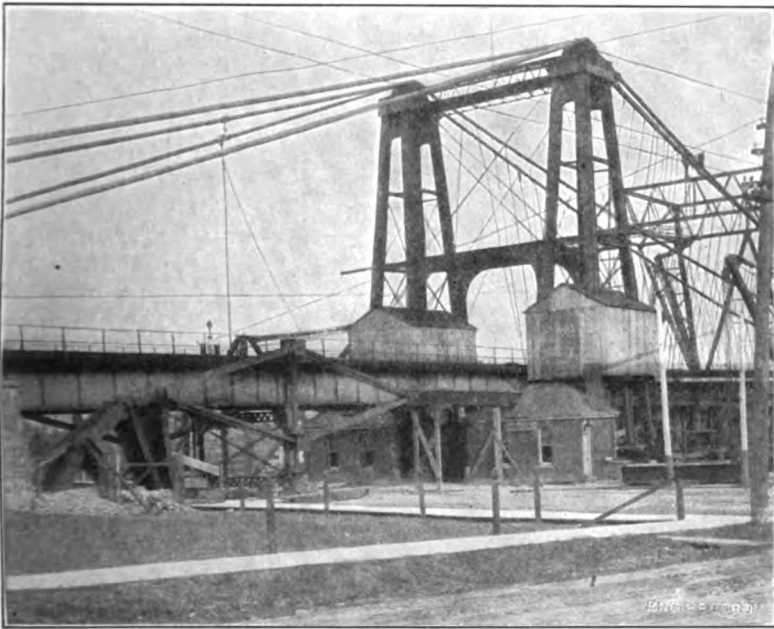

ADJUSTMENT TOGGLE IN TEMPORARY ERECTION ANCHORAGE.

tion clearance. Six horizontal operating levers were inserted in the capstan head at the foot of the vertical screw in each of the four adjustment toggles and two men on each lever slacked them off under a stress of over 1,000,000 pounds each, lowering the ends of the semi-arch trusses. One of them being inadvertently lowered too far was raised again by eighteen men on its toggle.

Theoretically the crown joints should have closed first at the top chords, and as they shortened under compression the lower chords or arch ribs should have come into abutting contact. On the contrary, the bottom chords met first, and when the tog-



gles had been slacked off and the anchorages entirely released, there still remained a clearance of  $\frac{1}{2}$  inch between the ends of the middle top chord sections and all the compression at the center was taken through the bottom chords, whereas 700,000 pounds of it should have been taken in the top chords. The anchor chains were then removed and drift pins and bolts were taken out of the rivet holes in the bottom chord splices, allowing the joints there to close more accurately and reducing the crown opening to  $\frac{1}{4}$  inch.

As the ends of the center lengths of top chords could not be brought to contact, it was determined to separate them a little

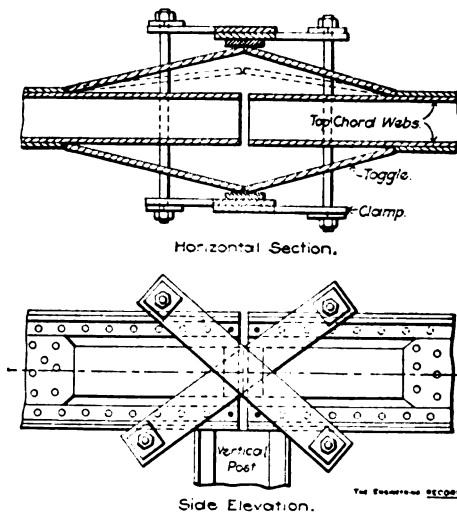

TEMPORARY ADJUSTMENT TOGGLE AT CROWN.

more and insert a filler thick enough to wedge them apart and develop the required compression when they were released and thus secure the desired distribution of compression between the top and bottom chords. This was effected by means of an improvised compression toggle constructed from simple materials at hand and applied to the top chord center joints. Pairs of square-ended, thick, flat steel bars were set in a V-shape each side of each joint, with their adjacent ends in contact and their opposite ones abutting against the vertical ends of thick plates riveted to the chord webs. A pair of similar heavy flat bars were arranged in the X-shape in the vertical longitudinal planes through the abutting ends of the V-bars, parallel with the chord webs, and

the ends of these pairs of bars were connected by horizontal bolts above and below the chords. Screwing up these bolts flattened the angles of the V-bars and forced the ends of the top chords 1 inch apart and a permanent shim of corresponding thickness was inserted, the toggle slacked off and removed and the adjustment effected so as to conform closely to the theoretical camber.

The lower floor was raised to its final position, the stiffening trusses of the suspension bridge were blocked up on the arch trusses and removed in one-panel sections, the new upper floor was put in, the field riveting was done with two 70-ton pneumatic

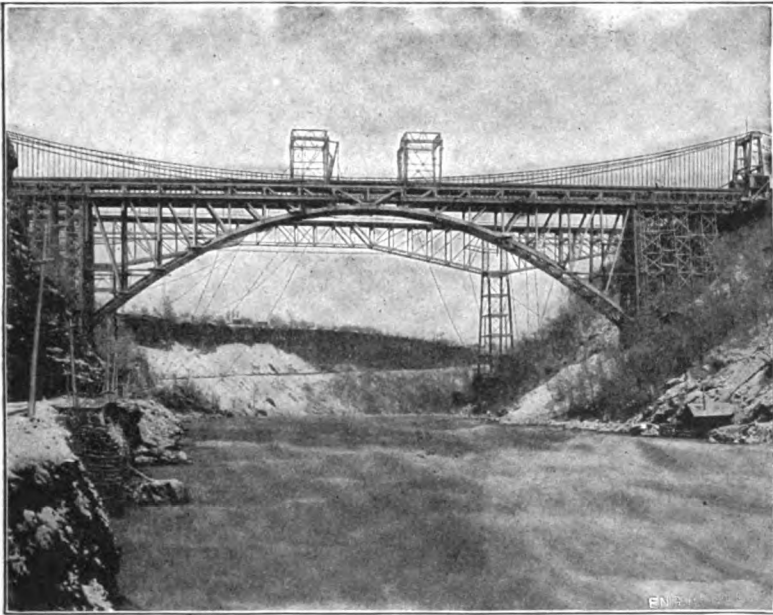

COMPLETED 550-FOOT ARCH SPAN ENCLOSING SUSPENSION SPAN, CANTILEVER SPAN IN BACKGROUND. THE THREE TYPES OF LONG-SPAN RAILROAD BRIDGES.

riveting machines operated by a compressor plant on the American shore, and finally the main cables and towers on the old bridge were removed, all without serious accident or the interruption of the service of trains sometimes only 15 minutes apart. The contract for the superstructure was let June 15, 1896, erection was commenced September 17, 1896, and the bridge was tested July 29, 1897.

The single track viaduct across the Viaur River, on the road from Carmaux to Rodez, France, is about 1345 feet long

between abutments, and  $380\frac{1}{2}$  feet high from water level to track. The  $721\frac{1}{2}$ -foot center span is a three-hinge spandrel-braced steel arch of  $176\frac{1}{4}$  feet rise with horizontal top chord and polygonal

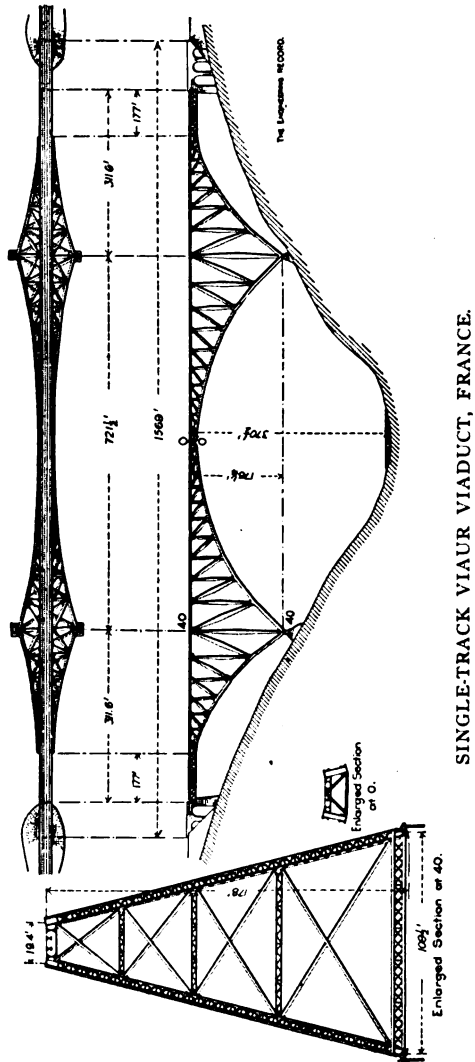

SINGLE-TRACK VIAUR VIADUCT, FRANCE.

bottom chord divided into 41.8-foot panels by posts perpendicular to the top chords, and has diagonals in one direction only. The battered trusses,  $109\frac{1}{2}$  feet apart at the skewbacks and  $19\frac{1}{2}$  feet apart at the roadway level, are connected together by the floor

system, by diagonals and by horizontal transverse struts between the bottom chords. The pairs of perpendicular posts are also connected by horizontal and diagonal sway bracing members. All members are made to resist compression and have riveted connections. At each skewback there is a 5-inch bolt 20 feet long, bisecting the angle between the lower chord and the post and anchoring the truss to a grillage of plate girders built into the pier masonry and accessible through an inspection tunnel. The arch trusses are continuous beyond the skewbacks to form cantilever arms resembling semi-arches. Each cantilever truss is  $226\frac{1}{2}$  feet long, and from its extremity is suspended one end of an 85-foot

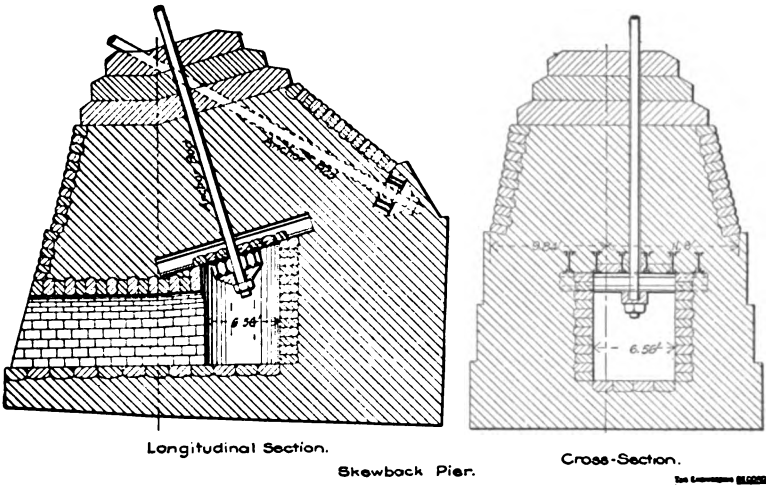

REACTION GIRDERS, SKEWBACK AND TUNNEL IN MAIN PIER.

Pratt truss, the opposite end of which rests on the masonry approach.

The top chords are about 43 inches wide, and their depths diminish from about  $2\frac{1}{2}$  feet at the skewbacks to about  $1\frac{1}{2}$  feet at the crown of the arch. They are made with a cover plate, two web plates and four angles each. At each panel point there are special sections of web plates spliced in which project below the line of the lower flange angles to form gusset plates for the connections of the web members of the trusses. The chords are stiffened at intervals by diaphragms formed of four solid web knee brace plates. The bottom chords decrease in depth and sectional area from the skewbacks to the crown and the ends of the cantilever arms, and are similar to the top chords except

that at the panel points the edges of the web plates are cut to curves of 33 feet radius, so as to connect the tangent with the angles.

The shorter perpendicular truss posts have I-shaped cross sections with plate or latticed webs, four flange angles and two or more cover plates. The longer posts have rectangular cross sections with four angles latticed on each side, and interior diaphragm frames made of angles. The diagonal web members are similar to the long posts, and both of them are of uniform width from end to end in the transverse planes, but are tapered

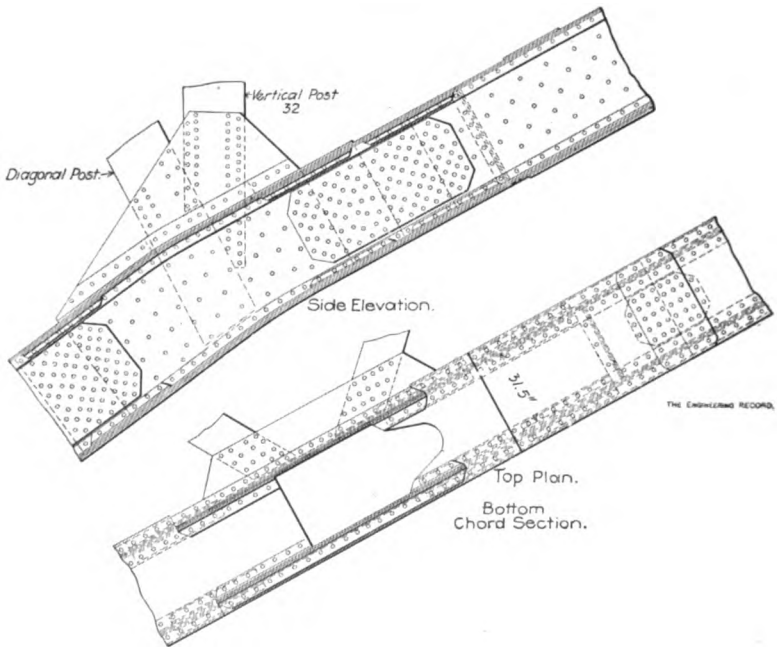

from the middle to both ends in the longitudinal plane. The sway bracing consists of from one to four panels of X-bracing in each bent. Where the depth of the trusses is least, the sway bracing consists of two inclined channel or plate-and-angle struts reaching from the ends of the lower chord horizontal transverse strut to the middle of the lower flange of the floor beam. Elsewhere the struts and diagonals all have I-shaped or rectangular cross sections, built up of four angles each, latticed, the rectangular ones having interior transverse stiffening plates. All truss members are latticed with small angles. The tops of each pair

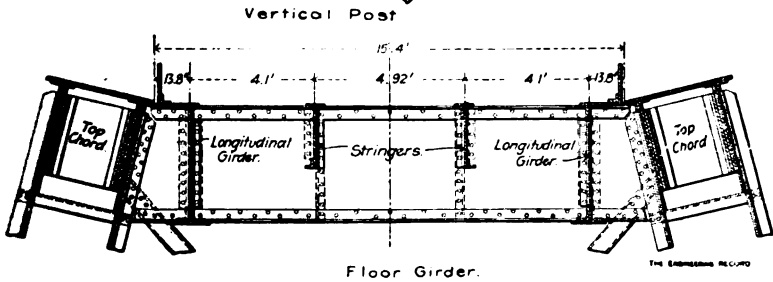
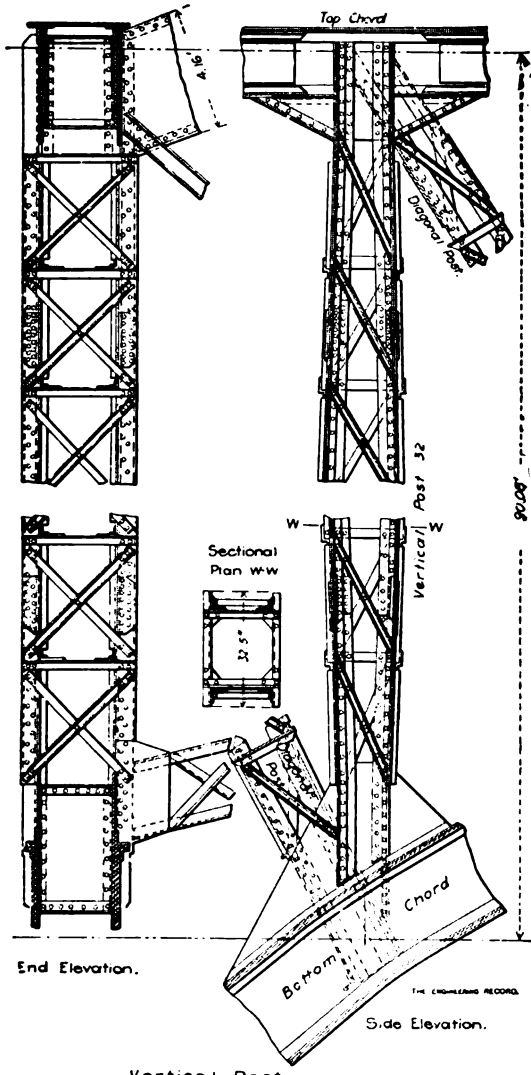

of perpendicular truss posts are connected by a double-web plate-girder floor beam about 45 inches deep, from the middle of which is suspended by two vertical and two inclined struts a light inspection platform, with a narrow gauge car track running from end to end of the bridge, accessible by iron ladders on the truss posts and a stair with hand rail in each lower arch chord. The solid floor has longitudinal fascia plates to retain the ballast.

At the skewbacks, the ends of the arch and cantilever lower chords and the perpendicular posts are riveted together on large, heavy gusset connection plates, to which are riveted the webs of special reinforcement plates tapering from a thin upper edge to a very thick forged angle flange taking bearing on the base plate riveted to it. The 5-inch main anchor bolt apparently has a forged head seated on an oblique bearing riveted to the outside of the chord. The base plate is normal to the maximum skewback reaction, and is inclined 25 degrees transversely, and 30 degrees longitudinally. It is fastened by four  $1\frac{1}{2}$ -inch bolts to the top of the upper cast-steel hinge piece, which has a bearing surface of about  $4 \times 5\frac{1}{2}$  feet, enclosing a 3-16-inch lead plate, on which the arch takes bearing.

The hinge casting has transverse and longitudinal webs connecting the 24-inch top plate and the convex hinge surface, which is a segment of a cylinder, with a 15-foot radius and its axis perpendicular to a vertical plane through the axis of the bridge. The lower hinge casting is similar to the upper one and has a  $6\frac{1}{2} \times 5\frac{1}{2}$ -foot base plate  $2\frac{3}{4}$  inches thick. Its concave hinge surface has a radius of 1.18 feet, and is connected to that of the upper casting by two bolts in slotted holes which allow limited radial motion, but prevent transverse displacement. The lower hinge casting is seated in the recessed top of a  $6 \times 7$ -foot cast-steel base plate 2 inches thick, with longitudinal ribs on the under side, which fit recesses in the top of pedestal and prevent transverse motion.

The base plate rests on the horizontal top of a cast-iron pedestal,  $8\frac{1}{2}$  feet square and 18 inches high, seated on a  $\frac{3}{4}$ -inch sheet of lead and fastened to the masonry by six 2-inch holding-down bolts and one long oblique anchor bolt connected to reaction separate beams built into the masonry. All the sliding surfaces are machined, and there is a hole through all the castings with clearance for the main anchor bolt from the arch trusses. The bearing between the base plate and the pedestal is made with six wedges providing an inch or more adjustment. The base-

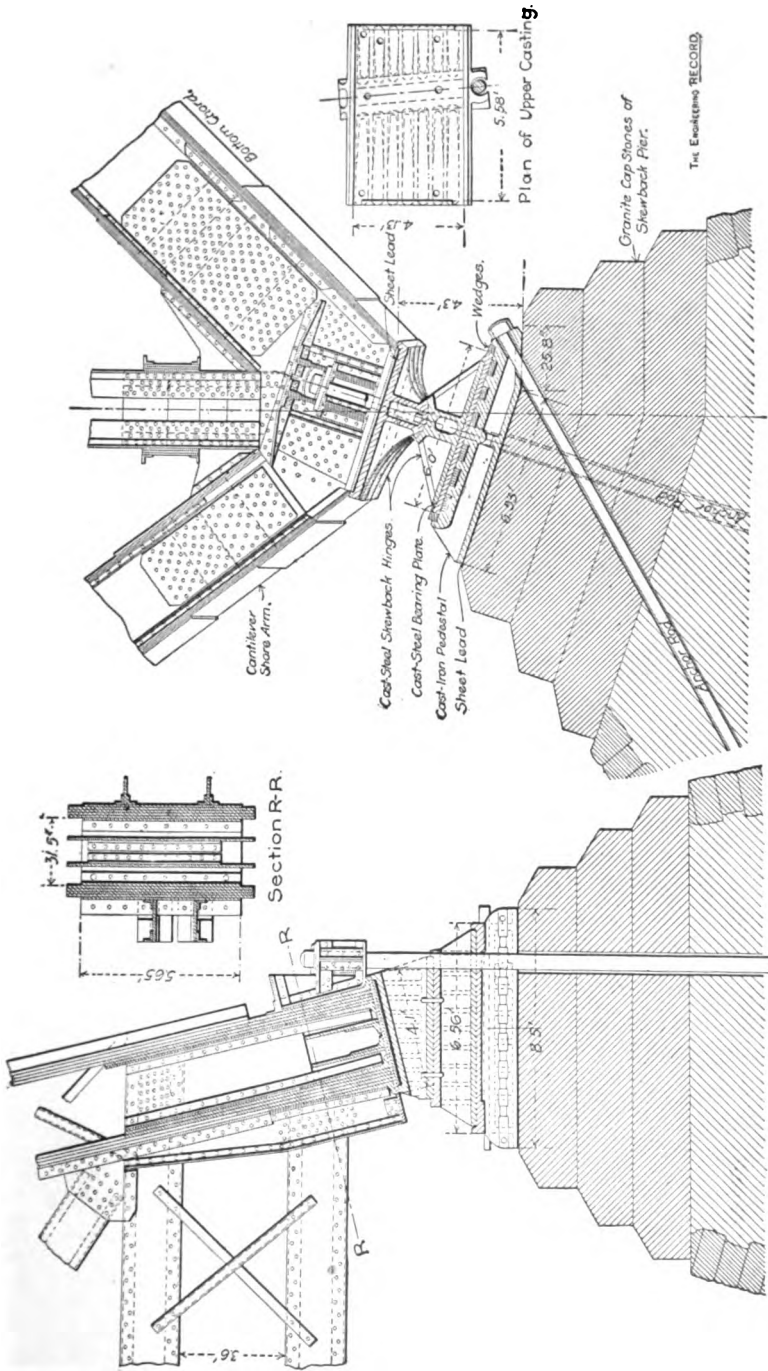

SKEWBACK HINGE, PEDESTAL AND PIER ANCHORAGE.



plate is fixed transversely by wedges between its edges and the flange of the pedestal.

The ends of the arch trusses have solid reinforced webs at the crown, where they are about 10 $\frac{3}{4}$  feet deep, with a clearance of 35 inches between the vertical faces, which are 49 inches wide at the bottom and 43 inches wide at the top. On the middle of each is bolted a vertical cast bed plate about 39 inches high and 48 inches wide, with horizontal top and bottom ribs forming guides for the hinge casting. The hinge casting takes bearing on the face of the bed plate with two single horizontal

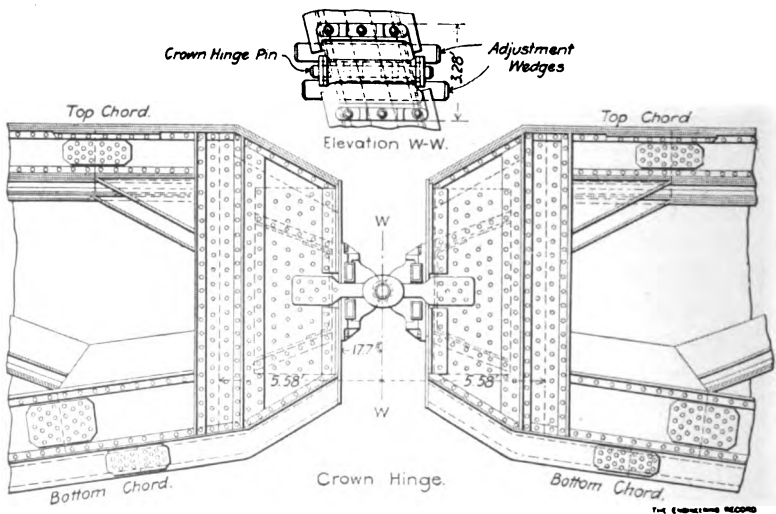

transverse adjustment wedges, and has a semi-circular bearing for the 8-inch horizontal cast-steel pin. The pin has a collar at each end which engages the casting, and beyond each collar it is prolonged to receive two short horizontal eye bars, one of which is riveted at the opposite end to the web of each semi-arch truss.

The bridge was illustrated in the "Revue Industrielle," September 16, 1899.

## PART III.

### ARCH TRUSSES.

In distinction from spandrel-braced arch spans, arch truss spans are here considered as those in which both top and bottom chords are curved, so that the whole truss is conspicuously arch shaped in general outline. They may be two-hinged, three-hinged or hingeless, and may carry the roadway at the level of the skewbacks, of the crown, or intermediately. In all hinged trusses both chords usually intersect at the hinge pins. In hingeless arch-trusses the top and bottom chords are usually parallel or are divergent at skewbacks. In two-hinge arch trusses the chords are usually parallel or converge towards the skewbacks, making lune-shape outlines. In three-hinge arch trusses the chords usually converge so as to give lune-shape outlines to the semi-trusses.

Extra members are required in the span on account of the necessity of supporting the roadway either with columns or suspenders from panel points of different heights. The wind and sway-brace systems are not likely to be as simple and effective as in spandrel-braced trusses, and considerable vertical displacements of the crown are produced by temperature variations in long spans. The depth of the truss can be made, within limits, independent of the length of span. The design is adapted to much greater variety of treatment than is the spandrel-braced arch, and often looks more graceful and artistic. Such trusses are generally designed for light or highway traffic and are often selected for parks and in conspicuous sites where graceful structures are specially desirable. They almost invariably have riveted connections throughout. Long spans must be erected on falsework or by the guyed cantilever method, and separate methods and travelers are usually required for the erection of the floor systems.

## CHAPTER VIII.

### THE BRUNSWICK, JEFFERSON, CARLSBURG, RIVERSIDE CEMETERY, OLD FORBES STREET AND BROOKLYN-BRIGHTON BRIDGES. SPANS 79 TO 168 FEET.

The Brunswick bridge is a highway structure of 78-foot 9-inch span which was described in the *Genie Civil*, Paris, of December 8, 1888. It has four three-hinge, lune-shaped arch trusses spaced only 4 feet apart. Each one is made with two pairs of light flange angles and flat zig-zag web members riveted to curved gusset plates between the flange angles. The crown pin has half-hole bearings on the solid plate webs of the arch ribs which are

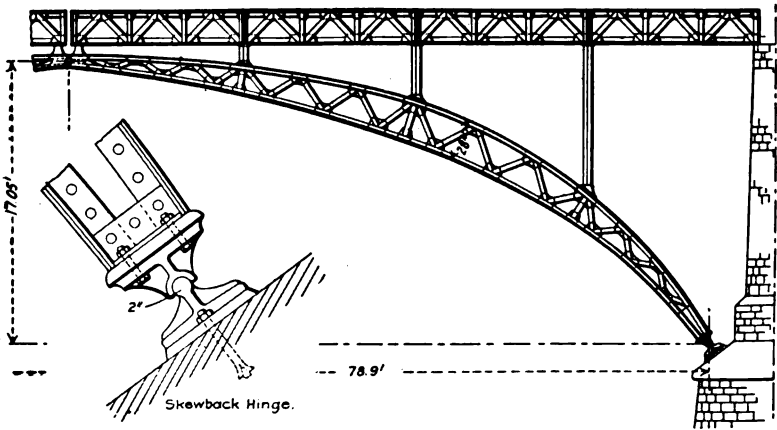

THE BRUNSWICK BRIDGE.

cut to clearance on the center line. The lower ends of the arch trusses have flange angles perpendicular to the web and to the center line which are bolted to shoe castings with concave bearings on the rounded transverse center ribs of the cast-iron pedestals. The stringers are light lattice girders supported on span-drel posts about 10 feet apart, and having expansion joints at the crown and at the abutments.

The Jefferson Bridge at the Louisiana Purchase Exposition, St. Louis, is an 80-foot span arch with two hingeless lattice-

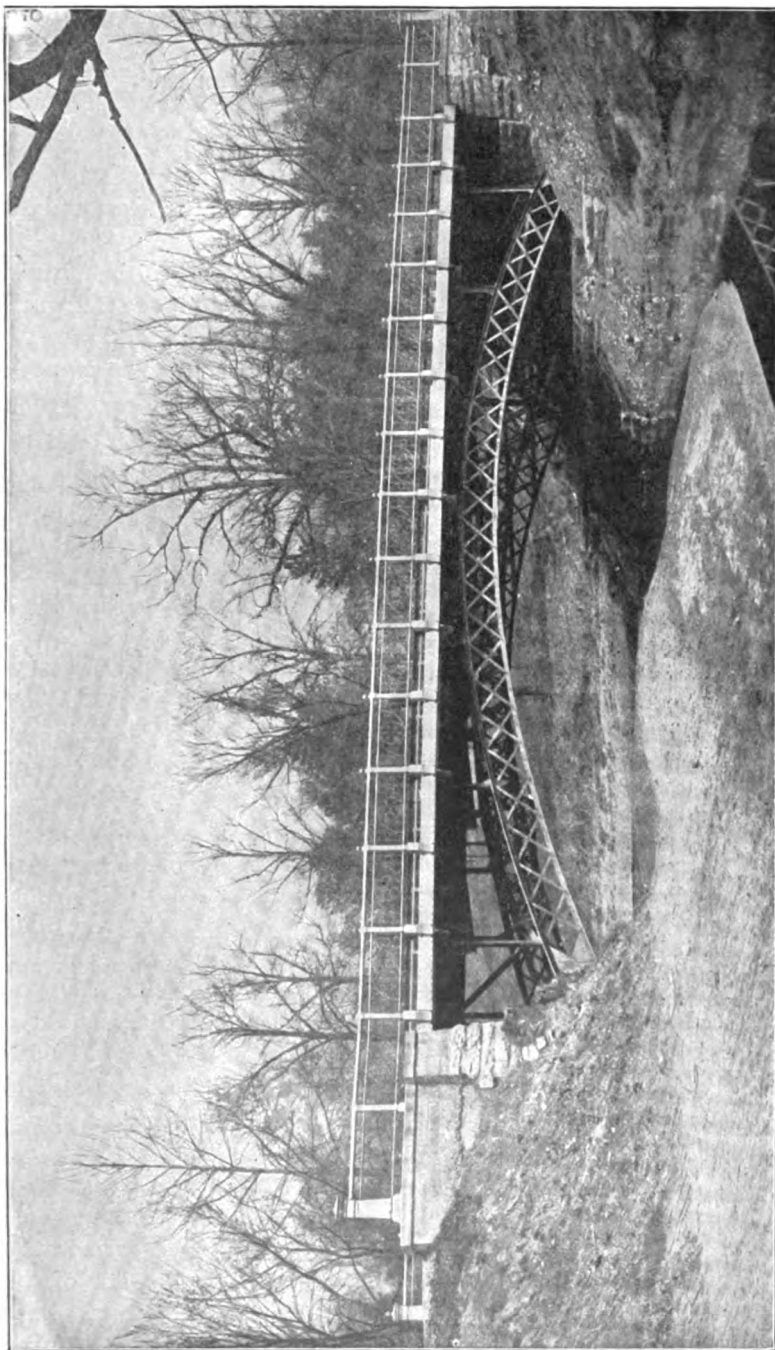

JEFFERSON BRIDGE, ST. LOUIS, 89-FOOT SPAN.

girder trusses supporting the floorbeams on the top flange and on vertical spandrel posts built of light angles with single sway-brace diagonals in each panel. The top flanges of the trusses are connected by lateral-diagonal angles, and the lower flanges are braced by sway-brace frames at panel points. The bridge carries a roadway 36 feet wide, and was moved from its original location, as shown in the illustration, and re-erected at the east end of the exposition grounds.

The Carlsburg Viaduct, Denmark, was described in "Engineering," London, July 14, 1899. It has two two-hinge steel truss arch spans, one of which has a length of 90 feet and rise of intrados of 38 feet, and the other has similar but smaller propor-

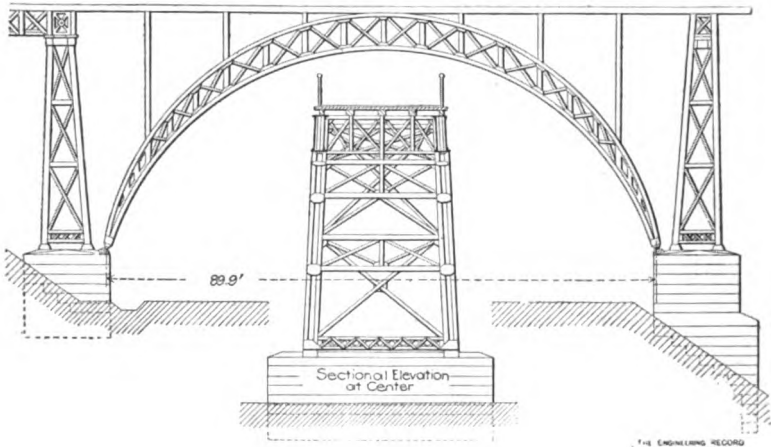

CARLSBURG VIADUCT, DENMARK.

tions. The intrados and extrados have different centers in the same vertical line, so that their curves intersect near the skewback pins and the chords have a crescent-shaped outline, and are divided by vertical members into X-braced panels of equal length but unequal horizontal projection. The trusses are battered, and are connected by sway brace frames in vertical transverse planes and by stiff lateral bracing in the plane of the lower chords. All connections are riveted except at the skewbacks, where castings are flange-bolted to the ends of the trusses and have open bearings for the horizontal hinge-pins which engage cast pedestals beveled transversely to correspond with the inclination of the trusses and seated on masonry surfaces normal to the center lines of the trusses. The 14½-foot roadway is supported from the arc

trusses by six bents of battered posts continuous across the trusses to the lower chords, and X-braced between the trusses and the floor-beams.

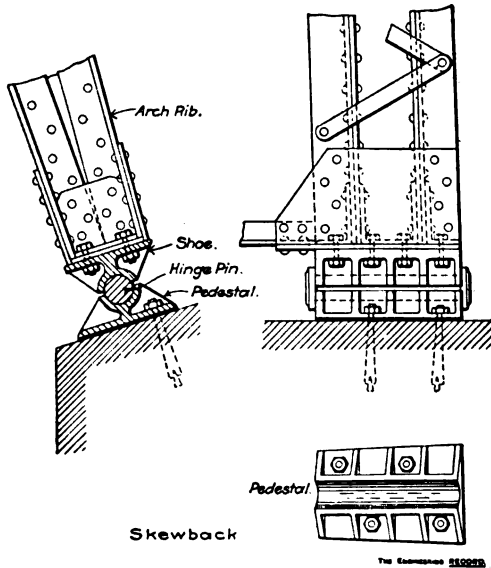

CARLSBURG VIADUCT.

The Riverside Cemetery bridge at Cleveland, Ohio, was described in "The Engineering Record" of April 20, 1901. It has a graceful center span with two arch trusses in vertical planes which support at the crown and spandrel posts four equal spans of lattice girder roadway stringers about 60 feet above the water. The two-hinge arch trusses are 142 feet long, 27 feet rise and 20

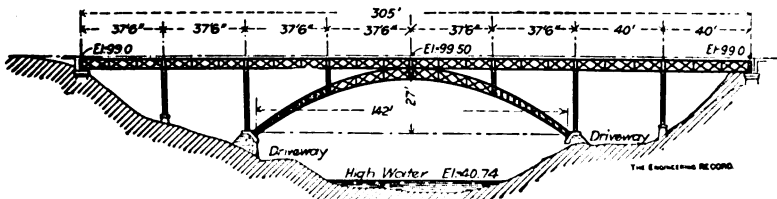

RIVERSIDE CEMETERY BRIDGE, CLEVELAND.

feet apart on centers, and are 2 feet deep at the ends and 5 feet deep at the crown. The chord angles are accurately bent to parabolic curves, and are connected by solid web plates at the ends and by X-bracing between the haunches. The diagonal members in the trusses and in the roadway girders are pairs of angles

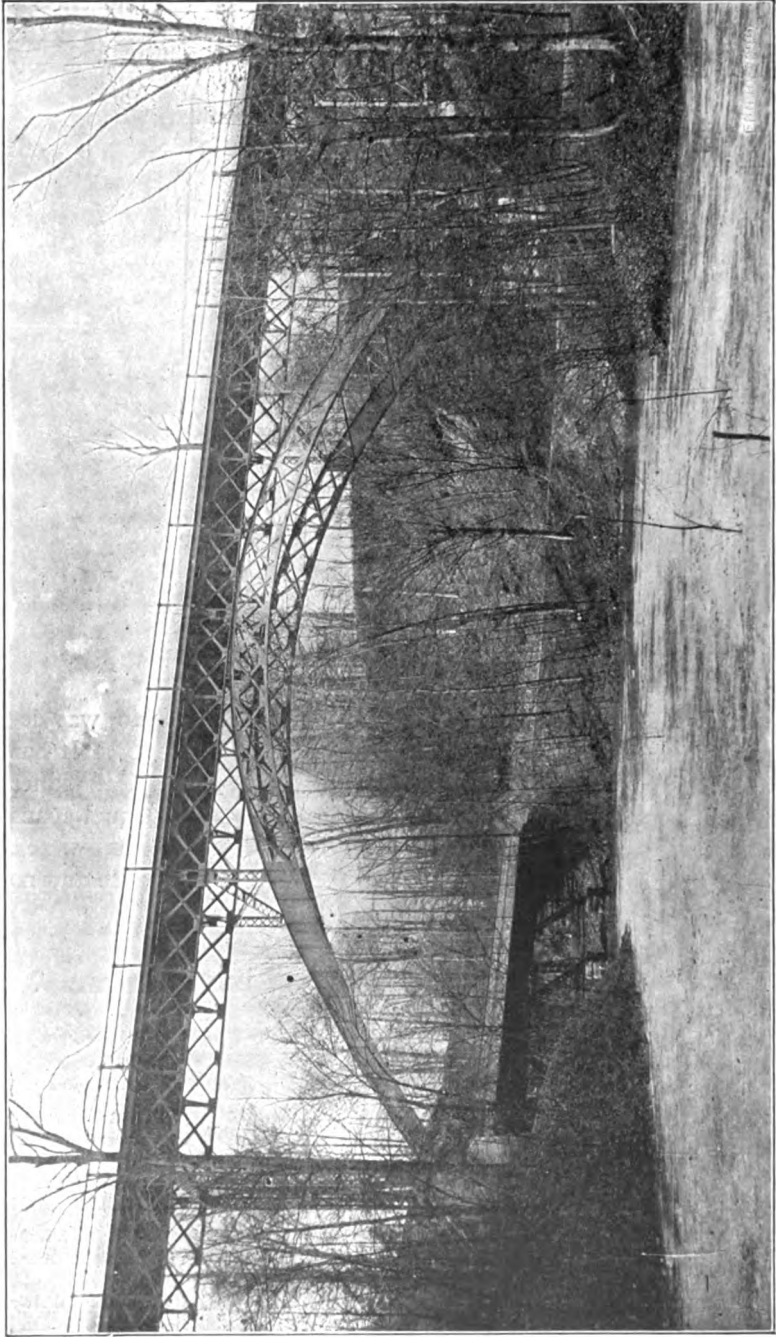

THE RIVERSIDE CEMETERY BRIDGE, CLEVELAND, 142-FOOT SPAN.

riveted together back to back to make T's with their webs turned outward so that their flanges clear at intersections and are riveted there and at the ends to connection plates with tangentially curved edges. The 6-inch skewback pins have full hole bearings in the rounded ends of the trusses and in the cast pedestals seated on inclined pier surfaces normal to the center line of the truss. The

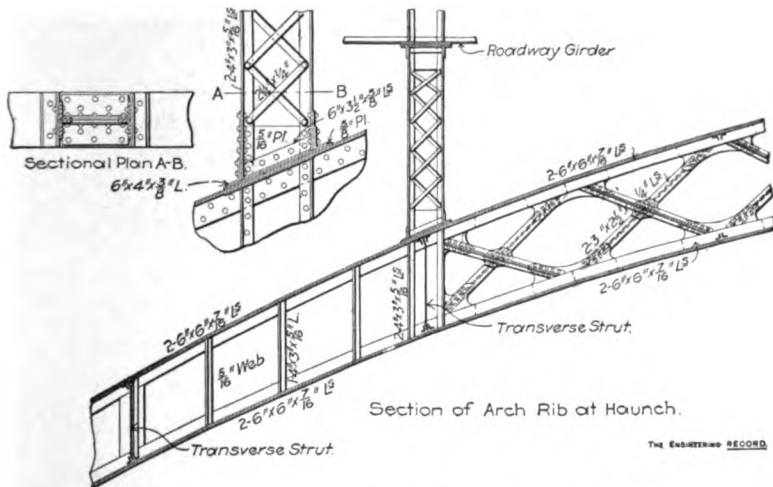

trusses are sway braced by thirteen lattice girder struts in vertical planes. Their flanges are in the planes of the truss flanges, and have oblique connection plates bent on opposite sides of their webs. They are X-braced in all panels by pin-connected top and bottom lateral rods.

The spandrel posts have oblique base plates riveted to the top flanges of the trusses and horizontal cap plates riveted to the arch trusses at the crown, and have sliding seats on the abutments, the vertical posts on the skewback piers being rocker roadway girders. The roadway trusses are rigidly connected to bents with top and bottom pin connections. The 15-inch floorbeams, 12½ feet apart, are supported at the ends of the roadway girders on horizontal flange angles riveted to tie plates connecting the end verticals of adjacent girders; at intermediate points they are web-connected to the vertical members. They have knee-brace angles to the lower flanges of the girders, and holes through the upper parts of their webs for the screw ended lateral rods, with adjustable nut bearings on convex washers seated in concave vertical angle plates. The sidewalks are carried outside the roadway girders on brackets, in the planes of the floorbeams,



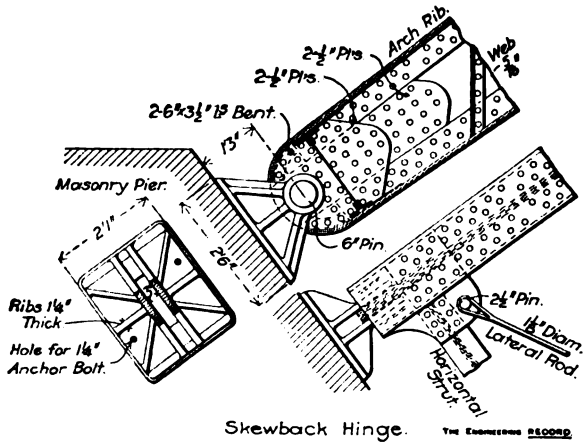

Skewback Hinge. THE ENGINEERING RECORD

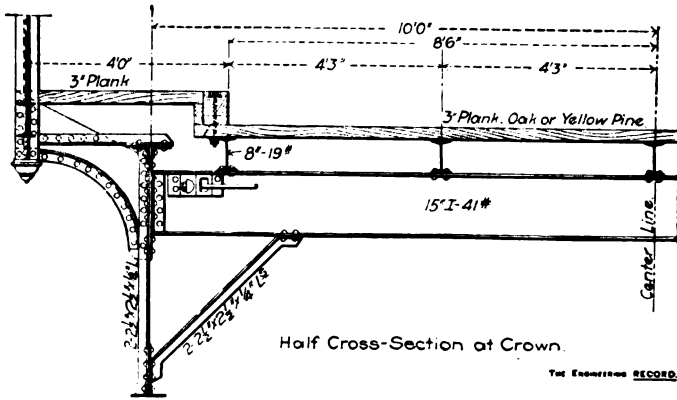

Half Cross-Section at Crown. THE ENGINEERING RECORD

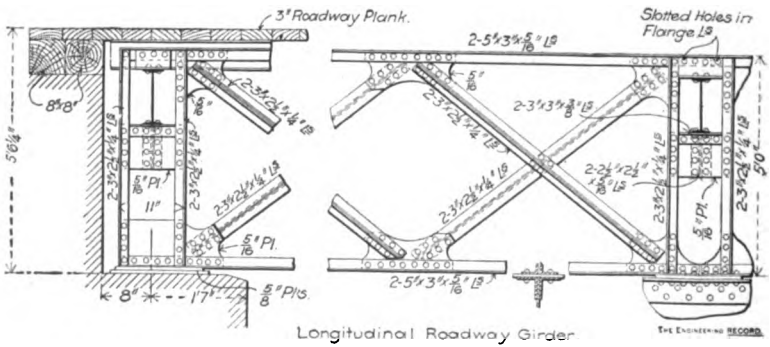

Longitudinal Roadway Girder THE ENGINEERING RECORD

which are peculiar for their oblique web plates and their anchorage to the top flanges of the girders.

The old Forbes Street Bridge, Pittsburg, was described in "The Engineering Record" of July 15, 1899. It had a 150-foot

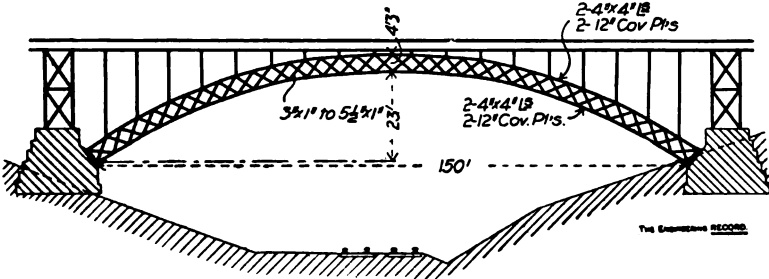

THE OLD FORBES STREET BRIDGE, PITTSBURG.

segmental arch span with three light lattice girder ribs 13 1-3 feet apart. These had parallel flanges 51 inches apart with a rise of 23 feet, and were braced together by light struts and diagonals in the plane of the top flanges only. The transverse struts were single small angles, and the diagonals were slender rods with

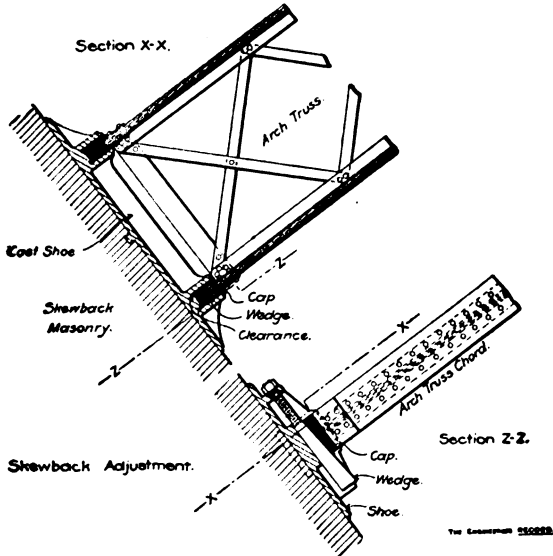

flattened ends with one small rivet in each. The vertical spandrel posts had T-shaped cross sections made with single bars or pairs of angles and web plates, and were riveted to the top flanges of the arch trusses with single oblique angle clips. They carried

three lines of longitudinal 12-inch I-beams supporting the wooden floorbeams of the double-plank roadway and the cantilever sidewalks.

The arch trusses had no hinges, and their ends were cut off square on radial lines. The ends of the chords engaged cast-iron blocks with beveled bearings on transverse horizontal wedges between the flanges of cast-iron abutment plates. The plates were bolted to the inclined pier masonry, and each received both chords of one arch rib. The wedges were arranged to be moved by screws to adjust the arch ribs, probably for making the center

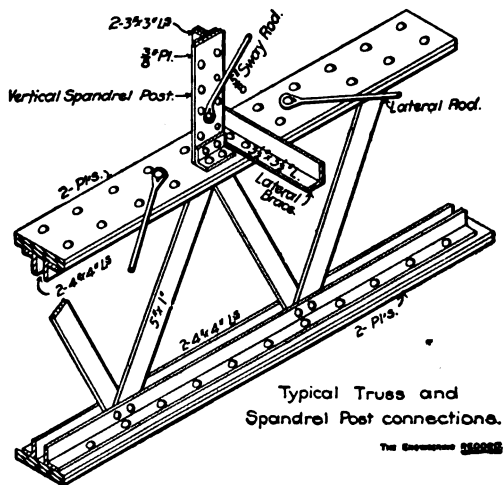

joint in erection. The bridge was built in 1874, and after twenty-four years' use was replaced by a plate girder arch.

The Brooklyn-Brighton Viaduct, Cleveland, O., has a 29½-foot roadway and two 7-foot sidewalks, and consists of a long trestle with 28-foot towers and 56-foot connecting spans and one 168-foot main arch span. This has two peculiar three-hinge arch trusses in vertical planes 26 feet apart on centers. The lower chords are composed of chords of a circular arc with a rise of 48 feet and a height of about 73 feet above water level. The top chord is horizontal for 42 feet each side of the center, and thence slopes at an inclination of about 45 degrees to its intersections with the vertical end posts 19½ feet long. The trusses are 7½ feet deep at the center and 19½ feet deep at the ends of the horizontal portions, and are divided in twelve 14-foot panels by vertical posts, with single diagonals in each panel. All panel points

are pin-connected, and all web members except the vertical posts at the ends and haunches have I-shaped cross sections made with two pairs of angles riveted together back to back and latticed. The other vertical posts and the top chords are made with pairs of channels, latticed.

The bottom chord is the principal member, and has a trough-shaped section made with 20-inch web plates, a 24-inch bottom cover plate and  $3\frac{1}{2} \times 3\frac{1}{2}$  and  $5 \times 3\frac{1}{2}$ -inch angles. It is made in single panel lengths with beveled butt joints spliced with web plates and bent bottom cover plates. All its pins are below the center line of the web, and at the crown there are half hole bearings with wedge-shaped clearances above and below. The pins at the center and ends of the bottom chord are 6 inches in diameter; the remainder of the bottom chord pins and those at the hip points are 5 inches, and the other top chord pins are 4 inches in diameter. The skewback pins engage full holes in the ends of the lower chords, vertical posts and cast-iron pedestals. The pedestals have one web in the plane of the axis of the pin and lower chord, and three webs at right angles to it, and have bases about 4 feet square seated on the inclined surfaces of masonry piers  $24\frac{1}{2}$  feet high.

The end vertical posts are continuous above the top chords to the roadway level and carry one end of longitudinal roadway girders, which are supported at the opposite end on the top chords of the arch trusses, at the hips. The bottom chords of the arch trusses are connected by transverse struts at panel points and by X-braces in every panel, all of which are made with I-shaped cross sections with two pairs of angles back to back, latticed, and have riveted connection plates engaging their flanges and the chord flanges. The top chords are X-braced by single angles, but have no transverse struts. The 42-inch plate girder floorbeams are seated directly across the horizontal top chords, and have tapered ends cantilevered about  $8\frac{1}{2}$  feet beyond them to carry the sidewalks.

The five lines of longitudinal 12-inch I-beams and channels which carry the roadway and sidewalk floors and the fascia girders are seated across the top flanges of the floorbeams, and the middle ones are raised on bent plate chairs to crown the roadway floor. Provision is made for two street car tracks, the outer rail of each being in the center of the truss. Each rail is carried in a trough made with three 12-inch channels, two having vertical and one a horizontal web, riveted together to make an H-shaped

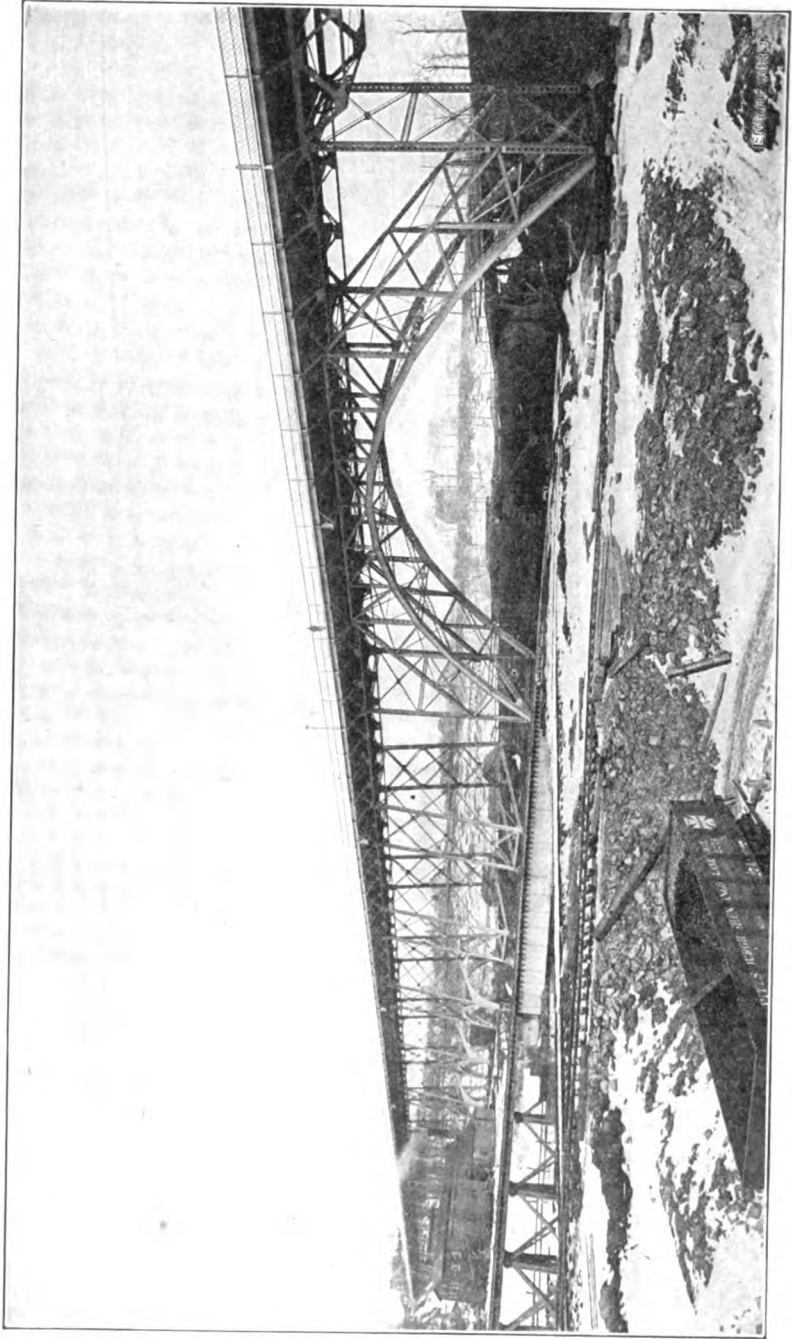

THE BROOKLYN-BRIGHTON VIADUCT, CLEVELAND, 108-FOOT SPAN

cross-section with the flanges down and out. These troughs also help carry the two layers of 3-inch floor planks. The span was erected by an overhead traveler which assembled it from one end and, moving on the top chords, erected the trestle falsework one panel in advance.

## CHAPTER IX.

### MANHATTAN AVENUE, SEINE, PASSY AND STONY CREEK BRIDGES. SPANS 168 TO 336 FEET.

The three-track viaduct of the New York Rapid Transit Railroad is carried across Manhattan avenue by a 168½-foot arch span about 50 feet high from the pavement to the track. It is the central feature of a conspicuous structure, and was designed with special effort to secure harmony with the landscape and be an attractive feature in the locality of fine streets and residences. The principal features of its design and erection are reprinted from "The Engineering Record" of March 28 and Aug. 8, 1903.

The three lattice-girder two-hinge ribs, 24½ feet apart, have their center lines curved to segments of a parabola, but the two sides are not equal about the crown. This discrepancy arises because one skewback hinge is 5 feet lower than the other,

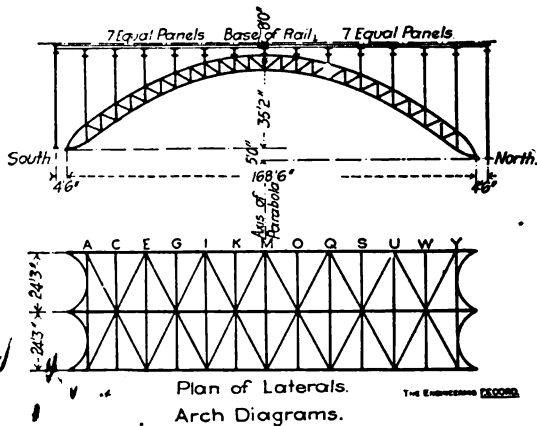

MANHATTAN VIADUCT, NEW YORK RAPID TRANSIT RAILWAY.

although both are on the same symmetrical curve as shown in the diagram. Each semi-arch supports six equi-distant spandrel posts which carry the roadway. The spacing between them is slightly different on opposite sides of the arch center, but the difference is not noticeable in the structure. At the foot of each

spandrel post, and intermediate between them, there is a vertical member in the arch rib which, together with the single system of diagonals, forms its web system.

The arch truss has parallel chords 6 feet apart on centers converging at the ends to receive the cast steel bearings from the skewback pins. Each chord has an H-shaped cross section

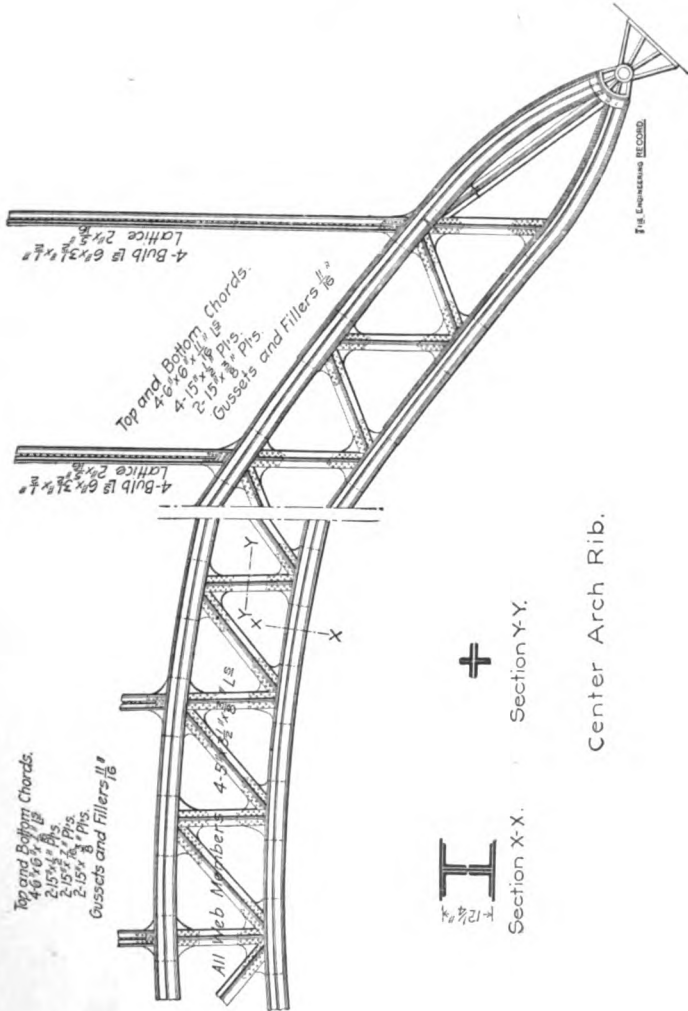

throughout made with four 6 x 6-inch angles and 15-inch flange plates. At panel points there are short sections of the web plates which extend beyond the inner flange of the chord to form gus-



sets receiving the field-riveted connections of the web members. The reinforcement plates on both flanges of the chords are continuous, and are slotted where necessary to clear the projecting gusset plates. In both chords the section is the same, and is diminished from a maximum at the springing to a minimum at the crown. The trusses were shop-riveted in four pieces each, field-spliced at the haunches and at the crown. The web members of the trusses are all composed of two pairs of angles riveted together back to back to make a cruciform cross-section engaging on its center line the gusset connection plates.

The details shown are for the center truss, and are much heavier than for the side trusses, which, however, correspond throughout to the details at the skewback and crown. In the side trusses the maximum chord sections each consist of four  $6 \times 6 \times 7$ -16-inch angles, two  $15 \times \frac{1}{2}$ -inch plates and two  $15 \times \frac{3}{4}$ -inch plates, and the web members each consist of four  $4 \times 3\frac{1}{2} \times \frac{3}{8}$ -inch angles. All spandrel columns have I-shaped cross sections made with two pairs of  $6 \times 3\frac{1}{2} \times \frac{1}{2}$ -inch bulb angles latticed and engaging the gusset extensions of the chord web plates. They carry transverse floorbeams 3 feet deep, which support the six longitudinal lines of 15-inch 60-pound I-beam stringers under the centers of the track rails, and the four lines of lattice-girders 5 feet deep, which carry the passenger platforms.

The floorbeams are framed in at the tops of the spandrel posts, and the stringers are seated on the top flanges of the floorbeams with their ends web-spliced continuously and having expansion joints at their connections to the towers at both ends of the span. Each pair of stringers and girders is braced by zigzag horizontal  $3 \times 3$ -inch lateral angles, and the floor system has  $4 \times 3 \times \frac{1}{2}$ -inch X-brace angles from the ends of alternate floorbeams, in the planes of the upper flanges of the floorbeams. The arch ribs are connected by thirteen transverse struts in vertical planes, one at the foot of each spandrel post. Each strut is a light lattice-girder 5 feet deep, with its flanges just clearing those of the arch rib, and is riveted through end gusset plates to the vertical web members of the ribs. There is a system of X-bracing in the curved plane of the top chords of the ribs which just clears the transverse struts. Each diagonal is composed of a pair of  $5 \times 3 \times \frac{3}{8}$ -inch angles riveted together back to back, and connected at the ends to gusset plates on the lower flanges of the top chords of the ribs.

At the first and fourth spandrel posts, counting from the

south skewback, the transverse struts of the west side of the arch carry at the center of the top flange a vertical post, which is in the center of the side track, and supports the end of the floorbeam section, as shown in the part cross-section of the span at point G. At this point the floorbeam is not continuous, but is made with two

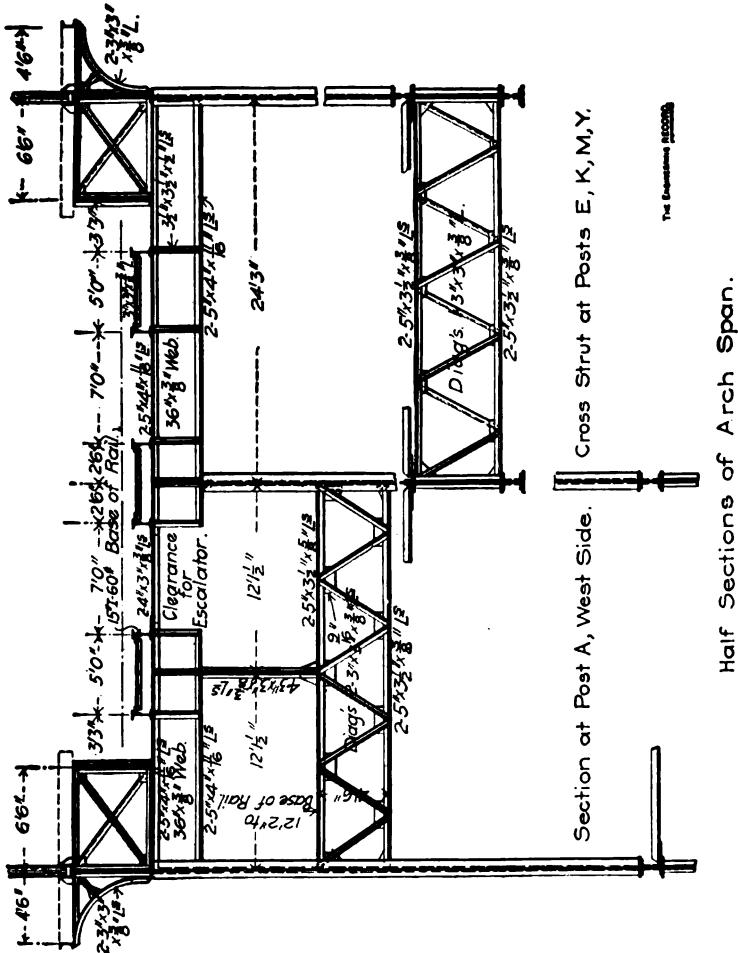

sections, acting as cantilevers for the support of the stringers and connected together simply by pairs of horizontal angles in the lines of their top flanges. The end transverse struts at points A and Y are plate-girder portals with curved bottom flanges which extend, like knee braces, almost to the skewback pins.

The plate girder viaduct and flanking towers at both ends

of the arch span were erected before the arch ribs were delivered, and a traveler was seated on the top of one tower and a stiff-leg derrick on top of the other tower. The traveler consisted of a horizontal timber platform sliding on the deck of the finished structure, and having on the front end a transverse A-frame about 50 feet high, supporting the topping lift of a 14 x 14-inch 15-ton boom 65 feet long, king-post trussed on all four sides, and rigged with four-part tackles of  $\frac{3}{4}$ -inch steel ropes. The derrick had a 14 x 16-inch 23-ton 58-foot boom rigged like the traveler boom. The arch ribs were delivered at the site in four sections each, the skewback sections weighing about 19 tons, and the crown sections about 14 tons each.

It was at first intended to assemble the arch ribs in halves in horizontal positions on the ground about 100 feet apart longitudinally on each side of Manhattan avenue, so as to avoid obstruction in the street. These halves were then to be brought to position between the piers, and each lifted by the boom of the derrick or of the traveler, and supported by them in the air until they were seated on the skewback hinges and the crown connections were made. This would have imposed very heavy loads on the derrick booms, and the necessity of providing falsework on which the traveler and derrick could be moved beyond the ends of the completed viaducts. In order to obviate these difficulties, the plan of erection was modified, and the work was carried on as shown by the accompanying pictures.

The end sections of the ribs were lifted by the booms and seated on the skewback hinges. The upper ends were supported on wedges between them and the transverse caps across the tops of the inclined timber shores. They were also back-stayed with tackles to the last floorbeams in the viaduct, and the transverse sway-brace frames were connected to them, and the booms were released. The 58-foot derrick boom was then replaced by a 72-foot boom made of an untrussed American fir timber 18 inches in diameter at the butt and 15 inches in diameter at the tip. The two crown sections for each rib were assembled together in a horizontal plane on the ground between the skewbacks. The crown joint was bolted up with a 1-inch transverse vertical plate to allow for adjustment, and the top and bottom flanges were stiffened by reinforcement timbers lashed to them. Each section was then lifted by the derrick and traveler booms on opposite sides of the span, which swung it by chain slings attached to the top flanges near the ends so as to permit them to raise it from the

ends of the completed viaduct. This operation obstructed the street and car tracks for only about one hour. The crown sections were swung to place between the skewback sections, and men mounted on both of them bolted up the joints at the

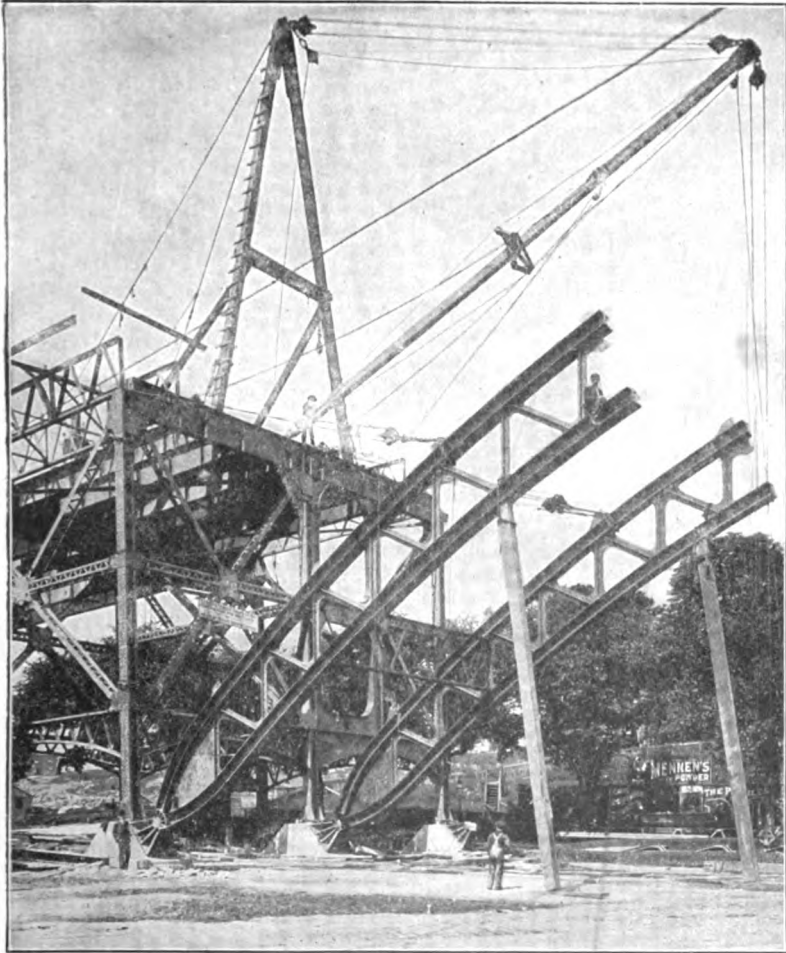

ERECTING AND BRACING SKEWBACK SECTIONS OF ARCH RIBS.

haunches. In order to do this, it was necessary to operate the adjustment tackles in the backstays and wedges at the tops of the inclined shores, and this was successfully accomplished so that each pair of joints was made in about an hour. The rest of the bracing was added and the derricks released, but the crown joints

were not riveted, the filler pieces remaining in them until such time as the permanent connection plates were ready and the temperature exactly 70 degrees, as computed, when the joints were



ERECTING DOUBLE CROWN SECTIONS OF ARCH RIBS.

opened by hydraulic jacks set between seats provided for the purpose.

Nearly all of the  $\frac{3}{4}$ -inch field rivets were driven by a special portable pneumatic riveting plant constructed by the contractors and used by them for general erection work, as well as for elevated railroad structures. It consisted of a small air compressor

mounted with receivers, oil engine and fuel tank on a steel beam platform arranged to travel either on a standard-gauge railroad track or with heavy wagon wheels on the highway. It had a capacity for seven pneumatic hammers, and was seated on the ground.

The erection of this span was accomplished by 30 or 40 men in two weeks, and the method which enabled it to be done with practically no obstruction to the important thoroughfare and without the use of falsework was considered satisfactory and economical.

The grounds of the Paris Exposition lie on opposite banks of the Siene, and are connected by several highway bridges, one of which, midway between the Pont de l'Alma and the Pont d'Iéna, was described in "The Engineering Record" of July 14, 1900. It is a foot bridge of about 394 feet total length, which is peculiar in appearance and presents unusual features of design and construction. It consists of a 246-foot center span and two 74-foot side spans symmetrical about the center line, and carrying a 26-foot sidewalk, partly deck and partly through, which is cambered 5 feet, in a uniform curve from end to end, and is 29 feet above the water in the middle. The center span is a two-hinge parabolic arch with a rise of about 49 feet to the center line.

There are two main arch ribs spaced  $29\frac{1}{2}$  feet apart and connected together by the floor platform and by fourteen transverse struts. Ten of these are overhead and serve as sway braces and have lateral angle X-braces between them. They are really light lattice girders, made of pairs of angles, with horizontal top chords and curved bottom chords like portal struts. The lower braces are simple latticed struts and are also connected with X-bracing in the transverse planes of the arch members. The cross-section of the arch rib is, from the skewback to just above the floor line, a box girder  $27\frac{1}{2}$  inches wide and about 3 feet deep at the hinge. Both extrados and intrados of the rib are parabolic lines so that the depth increases to about  $6\frac{1}{2}$  feet at the crown and gives it a crescent shape. From the floor level to the crown the solid side plates of the rib are replaced by vertical and diagonal members which consist of pairs of angles in each plane, connected by transverse lattice, virtually making a lattice girder. The ends of the ribs are flange-bolted to cast-steel shoes which take bearing on 10-inch pins set in cast-steel pedestals. The ribs are divided into panels about 13 feet long, and at each panel point between the haunches there is a stiff vertical member, supporting a main

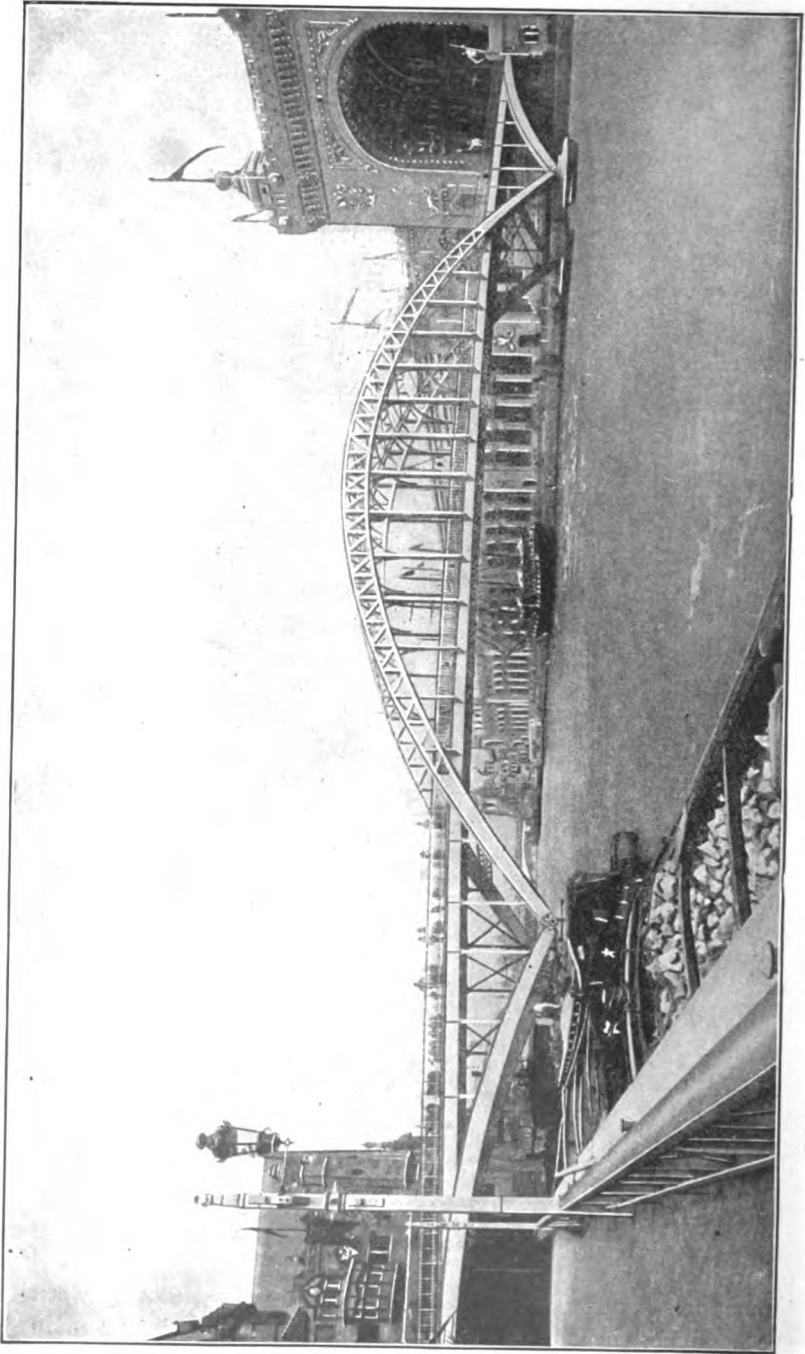

BRIDGE OVER THE SEINE AT EXPOSITION GROUNDS, PARIS, CENTER SPAN, 246 FEET.

floorbeam, which is riveted to the rib and pin-connected to the end of the floorbeam web. Outside the haunches the floorbeams

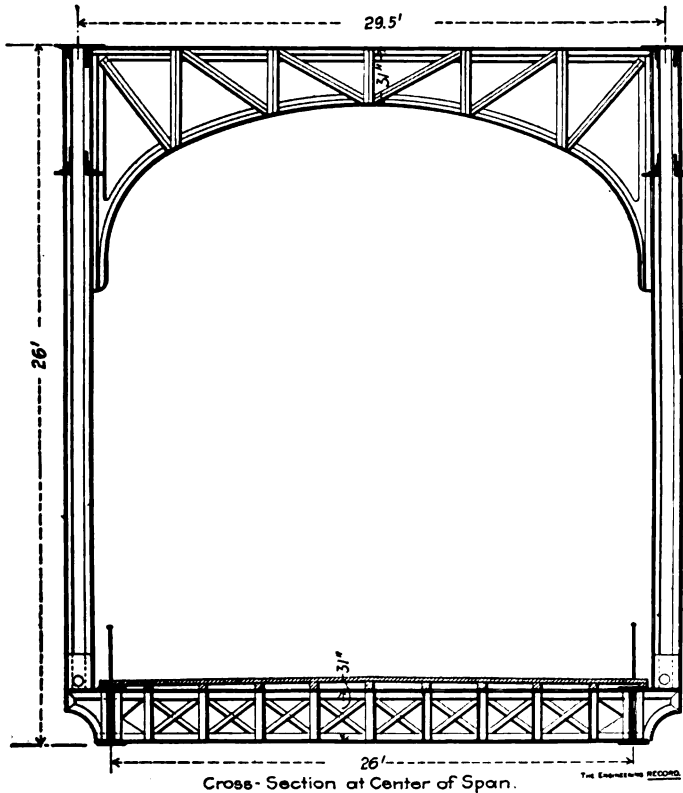

are supported on similar vertical members, which serve as columns and have riveted connections top and bottom.

The main floorbeams are light lattice girders 31 inches deep, with longitudinal wooden joists on the top flanges which are arranged to give the plank floor considerable crown in the center. Between each pair of main floorbeams there are three lighter intermediate ones.

The bridge is proportioned for a live load of 548 pounds per lineal foot. The center span is assumed to act entirely independently of the side spans and the latter, with the two rocker bents and the connecting floor platform, are assumed to act together as a balanced independent system.

The ends of the floor beams are connected by two lines of 31½-inch longitudinal plate girders 26 feet apart. In the side



spans the construction of the roadway is the same, and it is carried on two curved box girders in the planes of the arch ribs. These girders correspond to the lower ends of the arch ribs and appear like flanking semi-arches. At the shore ends they are

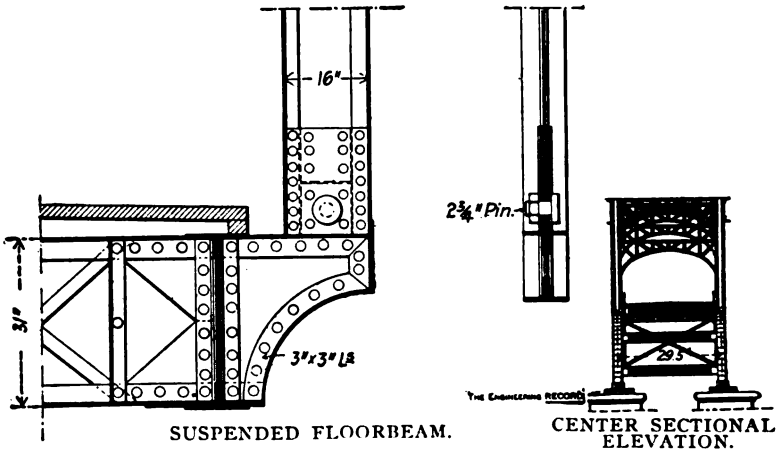

pin-connected to the tops of rocker bents, and at the opposite ends they have pin bearings on the same pedestals which support the center span. The upper ends of these girders abut against a transverse box girder with triple reinforced webs in horizontal planes. These girders are riveted to the longitudinal floor girders which are riveted together continuously from end to end of the bridge so as to act as tension members and take up the

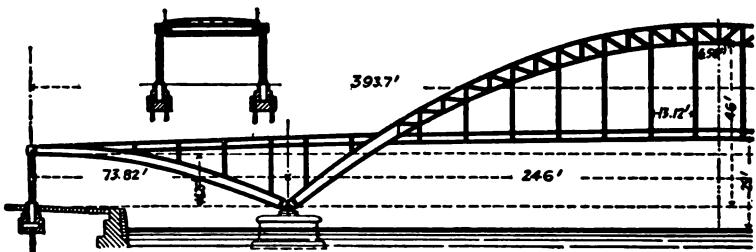

BRIDGE OVER THE SEINE, PARIS.

thrust of the semi-arches, making the reactions at the opposite ends of the bridge balance each other.

The cast-steel pedestal at the bottom of each rocker post is secured by four  $1\frac{1}{2}$ -inch bolts which have a curious system of

anchorage to the foundation piles built into the concrete footings, as shown in the accompanying detail. The reaction beams are mortised into the sides of the piles and bolted to them, but receive the anchor bolt bearings on the upper side and work

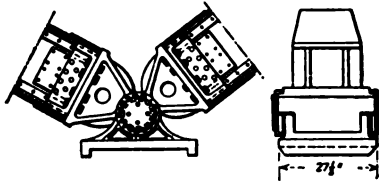

through rivets in tension, instead of receiving them on the under side and dispensing with connection rivets.

The bridge was erected from both ends simultaneously with-

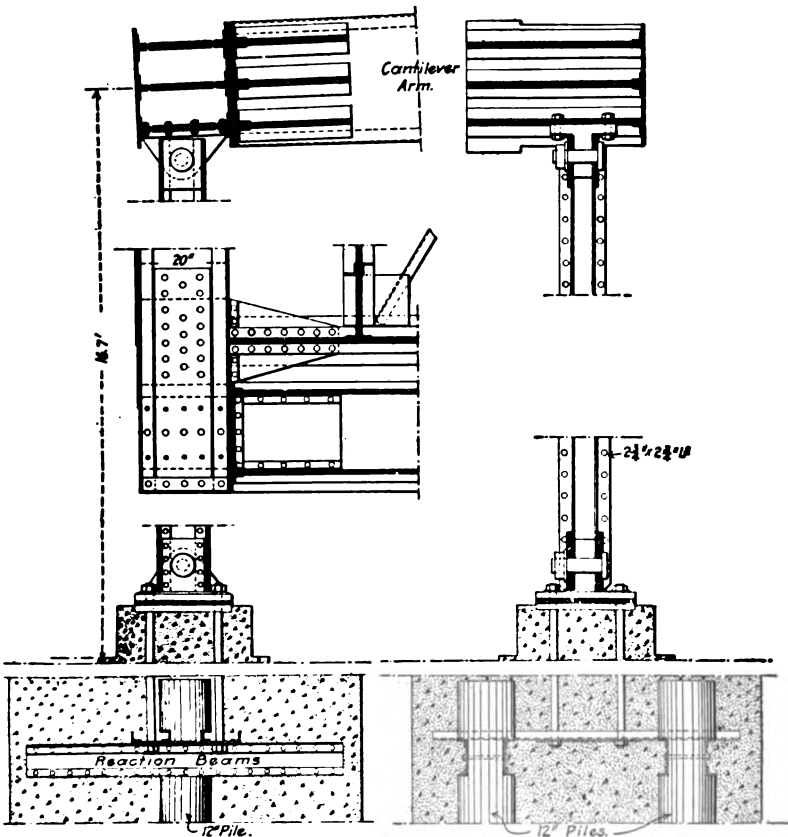

Rocker Bent and Anchorage.

out interfering with the heavy river traffic. On each bank a falsework truss was built from the quay wall or abutment to the main pier, and on it the floor girders were assembled, bolted, and launched in three successive sections until they projected several feet beyond the center of the pier. The main girders of the side spans were erected, the side spans completed and the falsework trusses removed. The lower sections of the main span arch ribs were erected from the cantilever projection of the floor platform, and the ribs were built up to one panel above the floor level. A temporary riveted connection was made between the longitudinal floor girders and the arch ribs, at their intersection, to take the erection strains, and a traveling derrick was set on the arch ribs, with which the remaining sections of the arch ribs to the center were assembled by the usual cantilever method. To connect the center panel, the temporary connection of the rocker bent was adjusted so as to depress the shore end of the bridge and raise the center of the river span. After the travelers were removed the web reinforcement plates and the splices of the arch rib sections were riveted, the remainder of the floor system was erected from the arch ribs and the permanent connections of the rocker bents were made. Eight tons of ballast were used to counterweight the floor girders during their launching, and 40 tons to counterweight the shore span and reinforce the anchorage for erection strains.

The erection traveler was a simple platform on wheels, with a pair of fixed booms about 25 feet long braced together and projecting in front. The booms were guyed to the tops of shear frames and were each rigged with two tackles, one to suspend the outer corner of a working platform and the other to handle the arch members. The tackles were operated by stationary hand windlasses set on the floor platform. The travelers were advanced by tackles anchored to the extremities of the arch rib and operated by the windlasses.

After the erection was finished the side spans were loaded with 13,227 pounds each and the anchor bolts of the rocker bents were screwed up tight so as to produce an initial tension in the floor stringers, when the bridge is unloaded and the temperature is normal.

The Western Railway of France crosses the Seine, in Paris, between the Champ de Mars and Corcelies, at a 1 per cent. grade on the Passy Viaduct, which contains a main channel skew span with two two-hinge arch trusses 281½ feet long and 31 feet 10

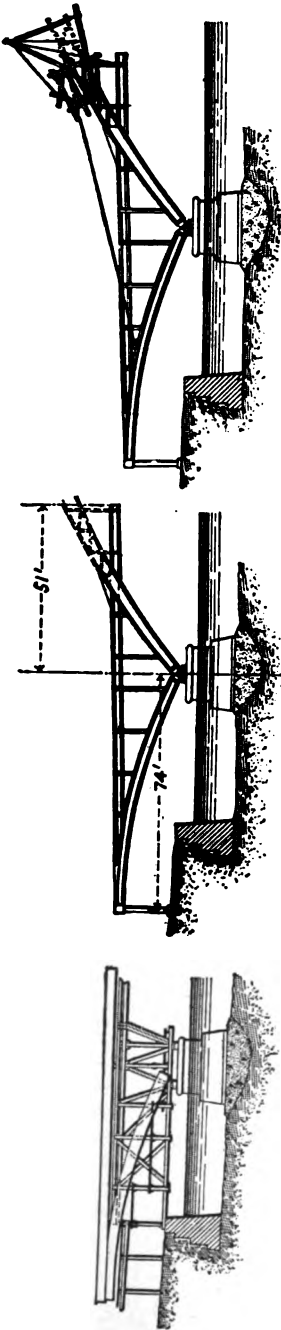

ERECTION OF THE SEINE BRIDGE, PARIS EXPOSITION

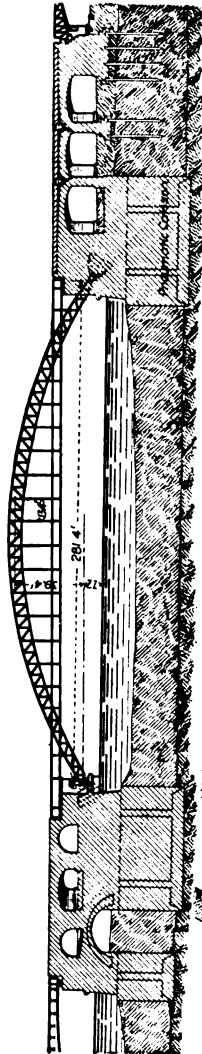

Elevation

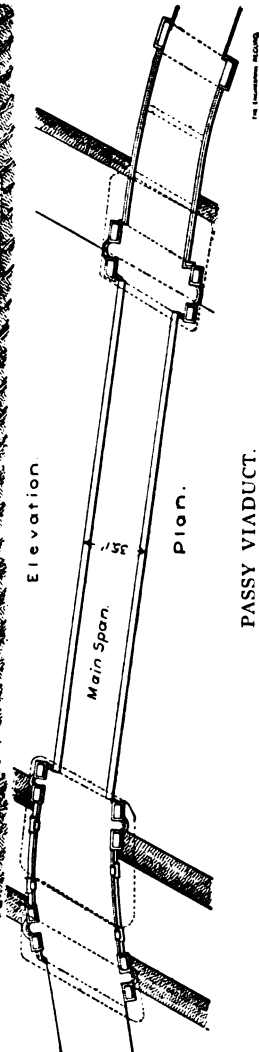

Plan.

PASSY VIADUCT.

inches apart on centers. The center line of the truss is a parabolic curve with a rise of 39.36 feet, and the depths of the truss perpendicular to it, at the crown and skewbacks, are about 6.6 and 4.9 feet, respectively. The trough-shaped chords are each made with four angles of varying sizes up to about 6 x 6 inches,

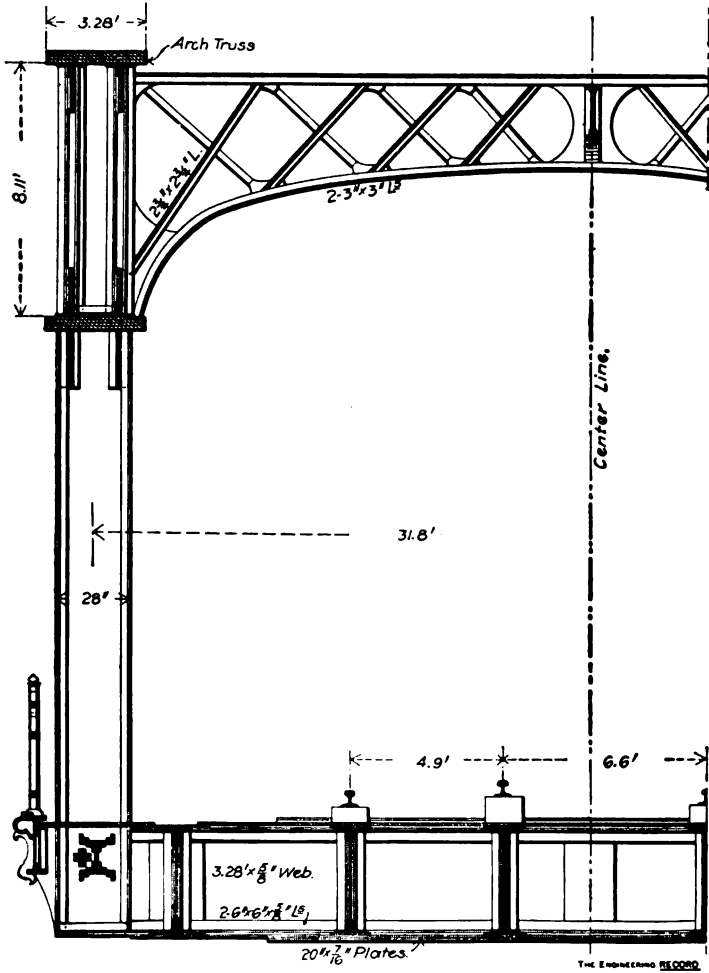

Half Cross-Section at Center.

two 18-inch webs and a 39-inch cover plate. The web members consist of verticals  $6\frac{1}{2}$  feet apart and diagonals of varying inclinations, all riveted to the chord web plates. Each web member is double, each duplicate part consisting of four angles riveted together back to back both sides of the web plates. In the end

panels the chord webs join to make solid full plates and form a closed box section, tapered to the ends, where they are seated in steel castings with hinge bearings on the skewback pedestals.

The clear width between trusses is 28 feet 7 inches, and the width of the bridge over all is 35 feet 5 inches. In the center of the span the trusses are connected by eight transverse lattice-girder struts with curved lower chords. The struts are con-

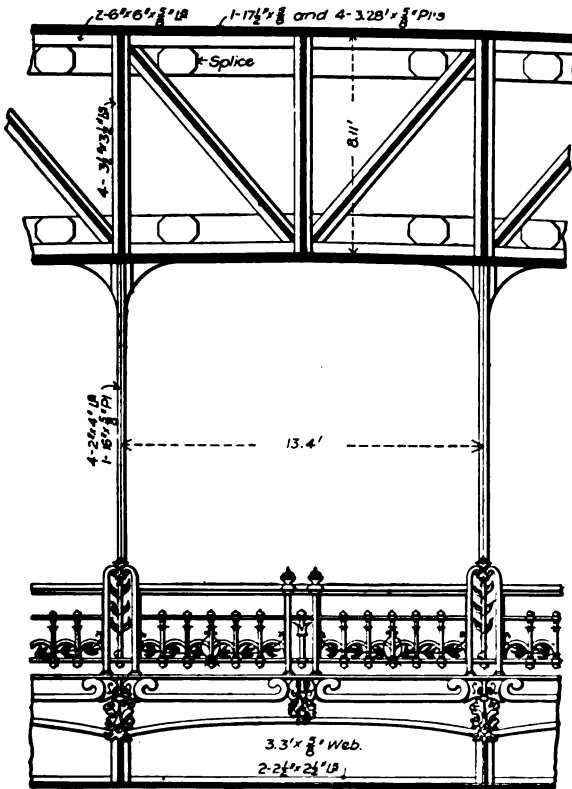

Elevation of Center Panel of Truss and Floor.

The ENGINEERING RECORD

nected in the middle by longitudinal struts, and the panels thus formed are X-braced to form the top lateral system. The clear height of the roadway platform is 24 feet 1 inch above the water, and it is 16 feet in the clear below the lower chord in the center of the truss. The floorbeams are 13 feet apart, and in the middle of the span are suspended from each truss by twelve verticals at alternate points. These verticals are riveted to the gusset plates

on the lower chords, and are very flexible longitudinally, so as not to transmit longitudinal stress from the floor to the trusses. At their intersection the floor and trusses are not connected, and beyond it the floor is free to move longitudinally on vertical supports from the top chords of the trusses. The trusses are connected by transverse struts and lateral diagonals, and have vertical sway bracing below floor level.

The stringers and floorbeams are covered with a continuous solid steel flat plate, and have rigid transverse connections to the trusses. The trusses are skewed 13 feet in the width of the bridge, and all the transverse members of the bridge are parallel and oblique. Arch stresses were calculated for full load, half load and for a load covering 65 feet each side of the center. The weight of the span is about 872 tons, and it was erected on pile falsework having an 82-foot center opening for navigation. This was closed by a span of lattice girders with curved top chords, which were erected on a pair of barges, floated to position and de-

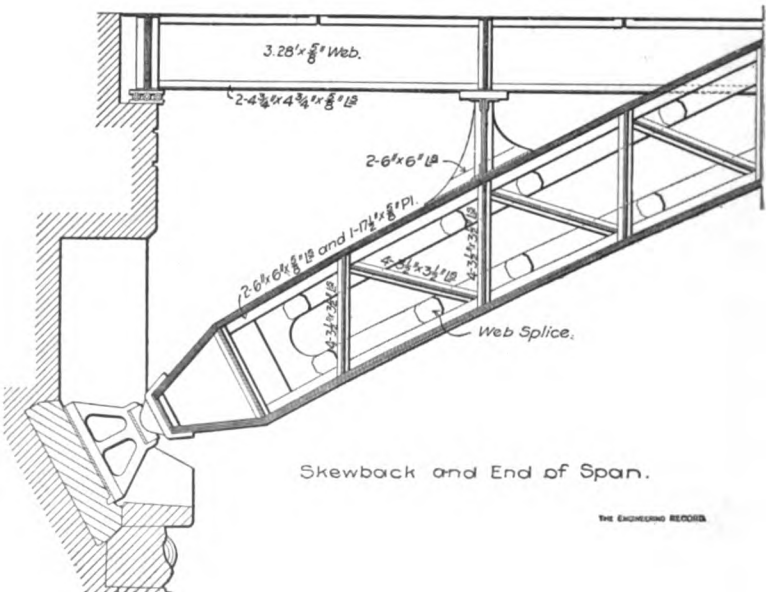

posited on the seats by sinking the barges. The erection was accomplished by a traveling gantry, which moved at floor level between the trusses. This gantry had a cantilever cap overhanging both trusses, and assembled them with movable two-hand windlasses. It had clearance through it for a material track on the

bridge axis. This bridge exemplifies the importance attached in Europe to the appearance of conspicuous structures. The design and erection were described in the "Génie Civil," June 2, 1900, and in "Engineering," Jan. 17, 1902.

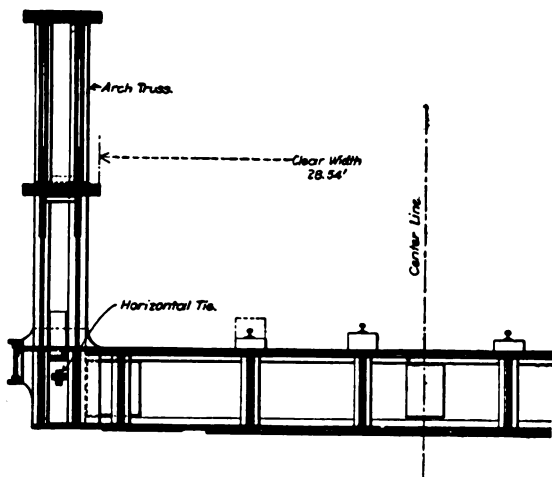

Half Section at Fifth Panel.

The Canada Pacific Railroad crosses the Stony Creek in the Rocky Mountains with a single-track, arch-truss span of 336 feet. The bridge is remarkable for its graceful proportions, the picturesque surroundings and the great depth of the gorge, which makes the structure one of the highest of its length in the world. The chasm is so deep that the lowest point is about 340 feet below rail level, and its sides are so precipitous that the total length of the bridge between the faces of the abutments at grade is only 486 feet, including 75-foot approach spans at each end, which are seated on abutment retaining walls about 40 feet high. The ground is so rocky that it affords excellent seats for the skewbacks, and allowed them to be seated at such a height as to give a satisfactory rise to the arch. This permitted the designer to select an ideal construction for the main span, utilizing the natural reactions for his compressive stresses, and building a very economical structure with attractive lines.

The chords of the pin-connected trusses are chords of eccentric circular curves with a versed sine of 100 feet for the bottom chord. The trusses are, in round numbers, 20 feet deep at the crown, 30 feet deep at the skewbacks, and are battered 1:10, so



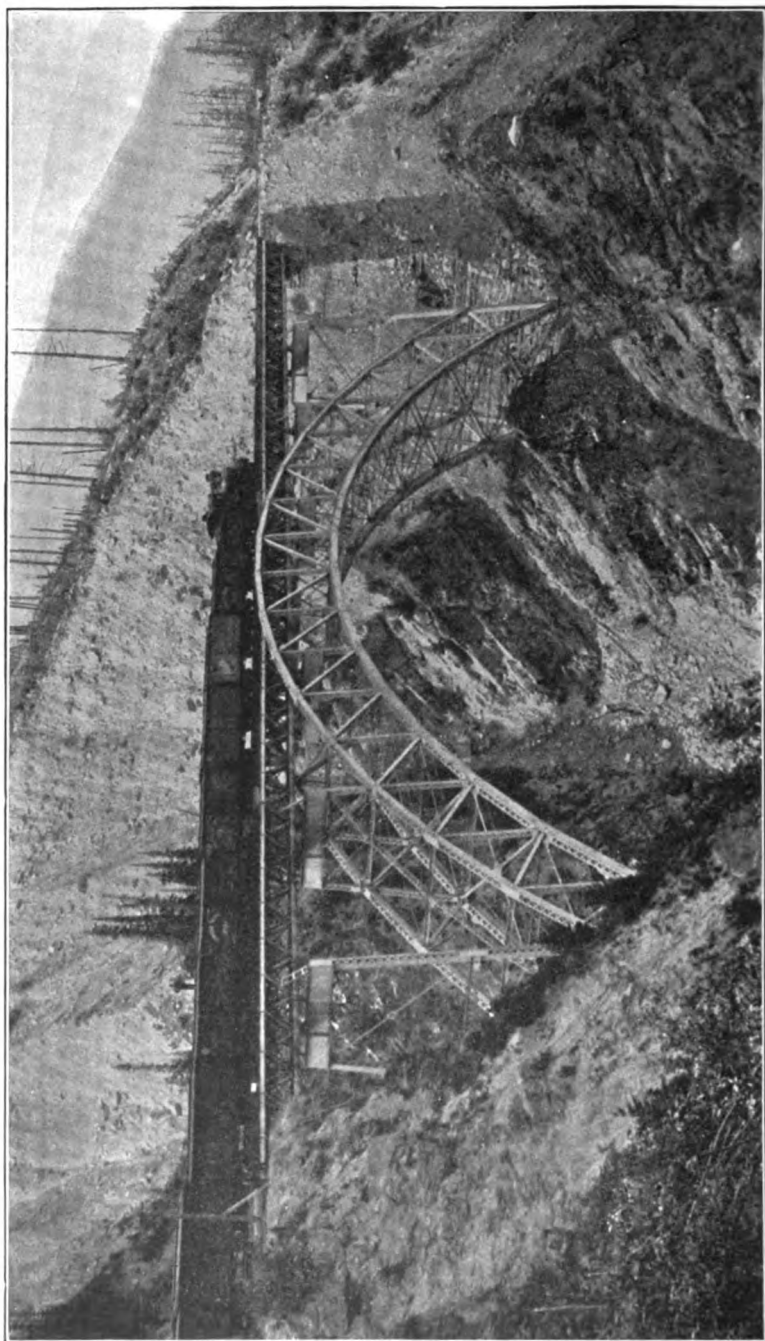

SINGLE-TRACK STONY-CREEK BRIDGE, SPAN 336 FEET, HEIGHT 340 FEET.

that they are 43 feet apart at the springing line and 19 feet apart at the center of the top chord. They are divided by vertical posts into sixteen 21-foot panels with single riveted diagonals in each. The top and bottom chord pins at the crown engage full holes in

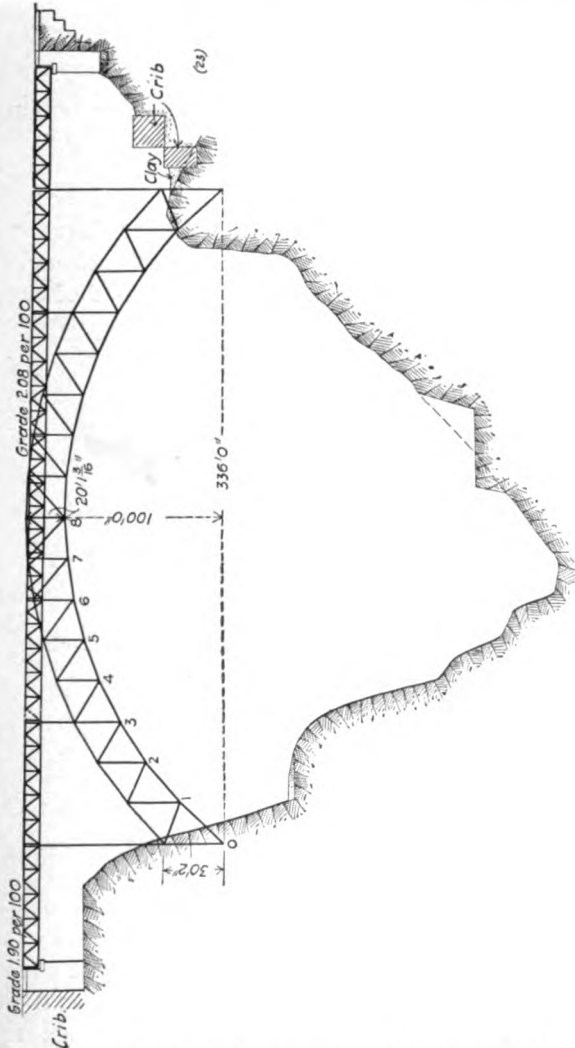
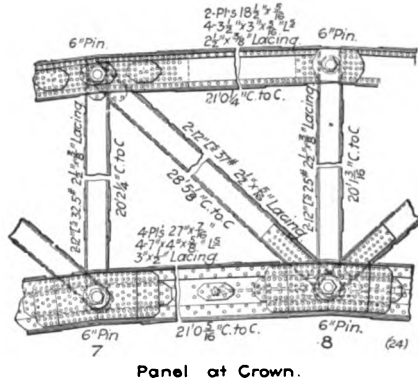

DIAGRAM AND PROFILE.

all members, so that there is no crown hinge, and the structure is a two-hinge arch which carries the railroad track on five riveted deck spans of 63 and 84 feet, with trusses 9 feet deep and 9 feet apart on centers.

The top chords are made with two built channels, latticed

top and bottom, and have a maximum cross section of two  $18\frac{1}{2} \times \frac{3}{8}$ -inch web plates and four  $3 \times 3\frac{1}{2}$ -inch flange angles at the haunches. The minimum sections at the crown and ends are the same, except that the thicknesses of all pieces there are  $\frac{5}{16}$ -inch and  $\frac{3}{8}$ -inch, respectively. Their center lengths diminish from 28 feet  $3\frac{3}{4}$  inches at the ends to 21 feet  $\frac{1}{4}$  inch at the crown. The construction is peculiar in that each panel is shop-riveted and shipped in three sections, which are field-riveted together with web and flange splice plates. The two end sections of each panel are about 2 feet long on the lower edge, and have the pin hole bored in the center. The flanges and the edges of the web plates are bent to the required angle on the radial lines. The top flanges have full length cover plates, which project at each end to form splices with the ends of the intermediate sections of chord, and



Panel at Crown.

the lower flanges are spliced to them with batten plates. The intermediate sections of chords have both ends planed square on radial lines, and have long splice plates riveted to their webs. In the two panels at the crown the short section of chord is omitted and the intermediate sections are longer than in the other panels, and terminate in jaw plates, which overlap and engage the same pin at the center point. The top chord pins have a uniform diameter of 6 inches, and their inner ends engage U-plates with horizontal wings, which are riveted to the top and bottom flanges of I-shaped lateral transverse struts 14 inches deep with I-shape cross sections made of two pairs of angles back to back, latticed. The single diagonal rods have sleeve nut adjustments and loop eyes engaging pins through the horizontal flanges of angle clips riveted to the top chord webs.

The bottom chord is similar to the top chord, and has a

maximum cross section at the haunches with two 27 x  $\frac{5}{8}$ -inch, two 27 x 9-16-inch and two 13 x  $\frac{5}{8}$ -inch web plates and four 7 x 4 x  $\frac{5}{8}$ -inch flange angles. The minimum cross sections are at the crown and skewbacks, where they are respectively composed of two 27 x 7-16-inch web plates and four 7 x 4 x  $\frac{5}{8}$ -inch angles, and of four 27 x  $\frac{5}{8}$ -inch and two 13 x 9-16-inch web plates, and

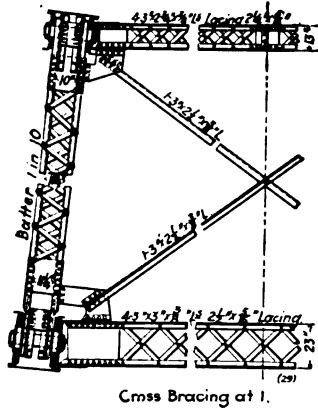

Cross Bracing at 1.

four 7 x 4 x  $\frac{5}{8}$ -inch angles. Each section is of the full panel length, with the joints planed radial and having full end bearings without clearance, and with half holes for the pins. The only splice plates are the bent covers on the top and bottom flanges. The pins are 6 inches in diameter, but have special bushings to give them 12-inch bearings on the chord webs. The bushings

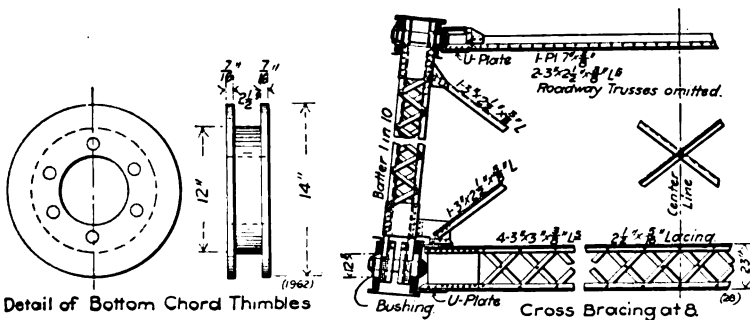

Detail of Bottom Chord Thimbles

Cross Bracing at B.

are made of three pieces of rolled steel plates riveted together so that the outer pieces form flanges locking them in position.

The bottom lateral system consists of transverse struts and X-braces all with I-shape cross sections made with two pairs of angles back to back, latticed. The diagonals have the same depth

as the bottom chords, and are field-riveted to flange connection plates on it. The transverse struts are riveted to U-plates on the chord pins and to vertical plates, which are also riveted to the feet of the vertical posts, and receive the ends of the sway brace diagonal angles. These plates are notched to clear the chord flanges, and are connected to both flanges of the diagonal angles. All bottom laterals are cut to clear at intersections where they are spliced by top and bottom  $\frac{3}{8}$ -inch flange plates with the edges trimmed concave. In the end panel a center longitudinal strut is run from the intersection of the diagonals to the center of the skewback transverse strut, to which it is connected by a notched flange, as shown in the detail. A similar center longitudinal strut braces the cross struts at the five panel points nearest each end of the top chords. All web members are made with pairs of 12-inch channels, latticed. All vertical posts have their flanges turned out, and all diagonal posts have their flanges turned in.

The 9-inch skewback pins engage half holes in the chords and in the riveted shoes, and full holes in the feet of the heavy end posts. The shoes have ordinary double webs corresponding with those of the chords, but differ from those in ordinary trusses in having their base plates grooved to receive six horizontal transverse 2 x 1-inch solid steel keys which lock them to the top plate of the pedestal. The pedestal has a 2 x 4 $\frac{1}{2}$ -foot cap plate 1 $\frac{1}{2}$  inches thick, which is inclined longitudinally and transversely to be perpendicular with the axis of the bottom chord, and is supported on two longitudinal vertical webs in the planes of the chord webs, which are connected by transverse webs and stiffened by pairs of outside angles parallel with the chord flanges. It has vertical and horizontal sole plates with a combined bearing of about 16 square feet on the out-stone masonry, to which it is secured with eight anchor bolts.

The roadway spans have deck trusses with lower chord pin bearings on rocker bents at panel points 0 and 3 of the arch trusses, and on transverse girders at points 6. Bents 3 and 6 are similar, except that the former has one and the latter has two vertical panels. The columns have their axis coincident with those of the truss verticals, and are braced together by horizontal and diagonal transverse struts, flange connected to their webs. The columns are seated on spherical discs, through the centers of which vertical anchor bolts pass which have nuts on the upper ends bearing on horizontal diaphragms in the columns, and eyes on the lower ends engaging the top chord pins. The discs are



convex on both sides, and engage spherical holes in the thick plates riveted to the feet of the columns and to the tops of the truss vertical posts, which project beyond the upper sides of the top chords.

The upper ends of the columns are connected by deep double-web transverse plate girders like floorbeams, with ordinary shoes riveted to their top flanges to receive the bearing pins of the

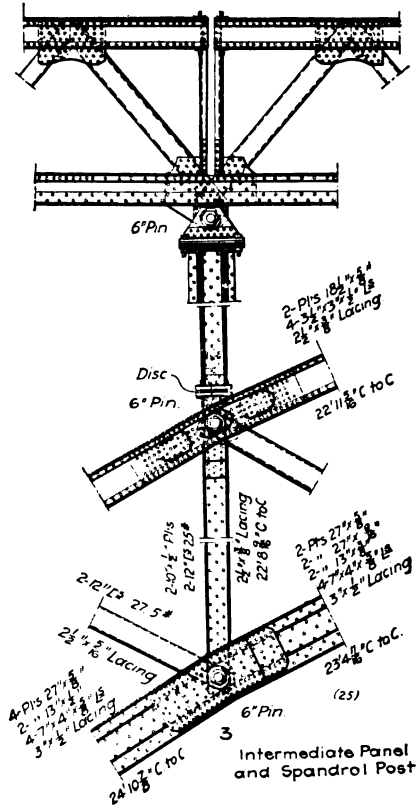

trusses. These pins engage interlocking jaw plates projecting from the ends of the webs of the lower chords of adjacent spans. The truss bearings are all fixed, and expansion bearings are provided at both abutments, to which temperature movements are transmitted through the rocking of the vertical bents. The top chords of the roadway trusses are at about the same height as those of the arch trusses at the crown, and the lower chords are at the same height as the truss top chords at panel points 5.

Therefore, at panel points 6, 7 and 8 the arch truss sway bracing is depressed, as shown in the special cross sections, to clear the roadway trusses. At panel point 6 the roadway trusses are supported on double-web transverse girders riveted to the vertical posts of the arch trusses, instead of to those of the rocker bents at the haunches and ends of the arch. Here the top lateral transverse arch struts are omitted and the arch top chords are knee-

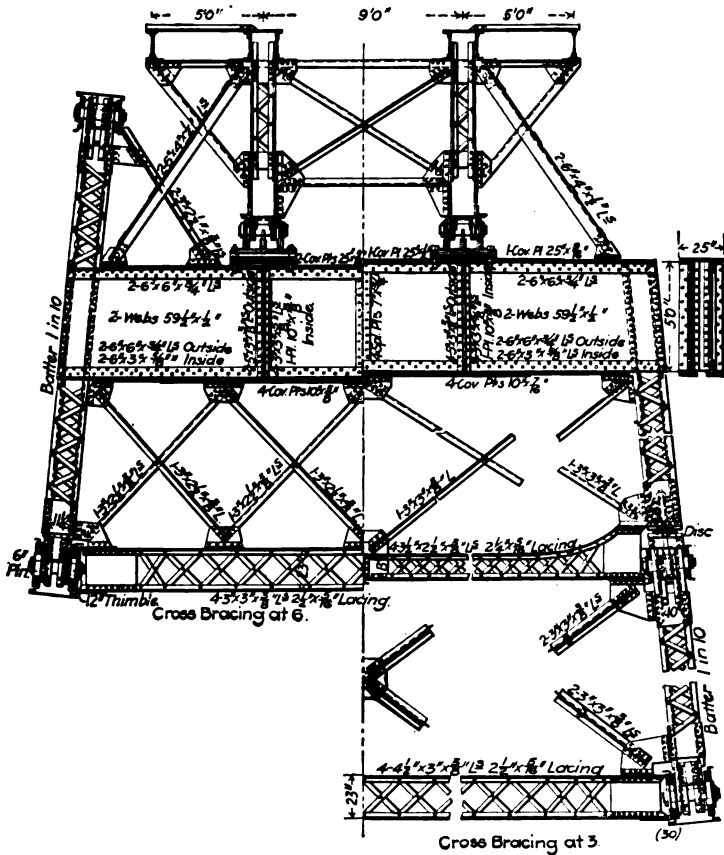

TYPICAL SEMI-CROSS SECTION.

braced to the transverse girder top flanges with pairs of angles passing between the pairs of angles, which kneebrace the top chords of the roadway trusses to ends of the transverse girders. These latter braces are peculiar in having pin-connected ends. The deck is made with very heavy ties 20 feet long, spaced close to-



gether and seated on the top chords with their overhanging ends carried by  $15\frac{1}{2}$ -inch plate girders on the ends of cantilever brackets 5 feet long and  $10\frac{1}{2}$  feet apart at panel points. The bridge was built of soft steel throughout, weighs about 1,021,400 pounds, and was designed in accordance with the specifications of the Canada Pacific Railroad for two locomotives with 120,000 pounds on a 14-foot 8-inch driving wheel base, followed by a train load of 4000 pounds per linear foot. It was erected on trestle falsework built up from the bottom and sides of the gorge, which were in some places terraced to give horizontal seats for it. This falsework was one of the highest ever built, and was composed of long and heavy timbers cut in the vicinity.

## CHAPTER X.

### **CORNHOUSE, PADERNO AND EADS BRIDGES. SPANS 377 TO 520 FEET.**

The Cornhouse Bridge over the River Aar, near Berne, Switzerland, was illustrated in the "Génie Civil" of Dec. 3, 1898, and in "The Engineering Record" of June 17, 1899. It is a very lofty and handsome structure, picturesquely situated and interesting for its importance, its graceful design and the difficulties encountered in building its foundations. Its maximum dimensions are about 1240 feet length, 41 feet width and 160 feet height, and it has five 113½-foot spans and one 376.6-foot span. The main span has two hingeless parabolic arch trusses, 43½ feet apart at the skewbacks, and 26 feet apart at the crown, with corresponding radial depths of 14¾ feet and 5¾ feet. The rise of the lower chord is 103.7 feet, and each top chord carries ten vertical spandrel posts, which support the lattice-girder roadway trusses. The trusses are battered 1:12 and are each divided into 34 panels by radial struts with a solid web plate transverse to the bridge axis and four Z-bars making up I-shaped cross sections. The diagonals in each panel are single channels with reinforced flanges, and are cut to clear at intersections, where they are riveted to flange connection plates.

The top chord is of inverted trough section with pairs of angles making T-shaped top flanges for its webs. Reinforcement plates, the width of both angles, are riveted to each flange outside the covered plate which connects the webs. The horizontal flanges of the lower web angles are reinforced and short connection plates are riveted to them and project inwardly to receive the lattice angles and the stiffened transverse diaphragms. The bottom chord is made of two built channels, with the flanges reinforced by plates of equal width with the angles, except the second one on the lower flange, which is twice as wide and projects inwardly, nearly to the center line to receive the lattice angles on its upper side. The cross sections of the top chord are 72, 61.5 and 108 square inches at crown, haunches and skewback, respectively, and the corresponding cross sections of the

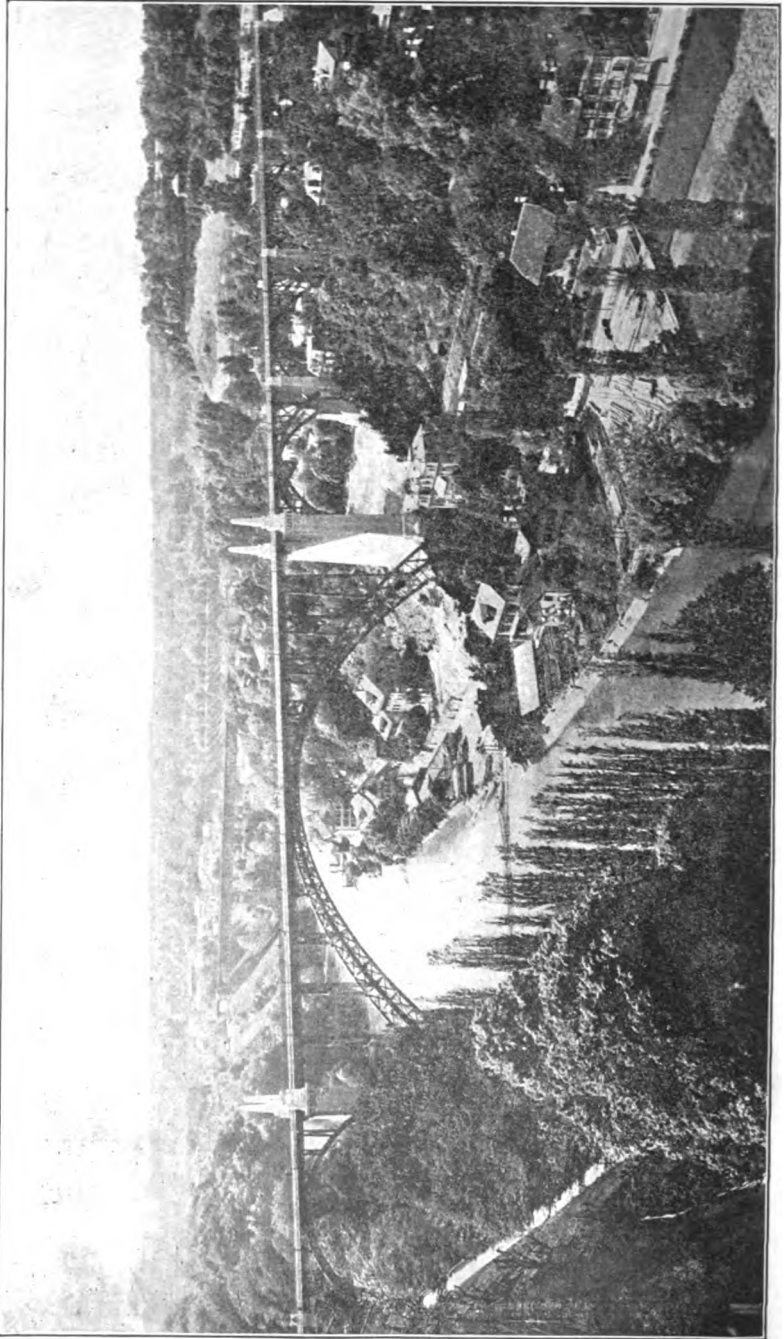

GENERAL VIEW OF THE CORNHOUSE BRIDGE, BERNE, SWITZERLAND.

bottom chord are 61.5, 72 and 140 square inches. The vertical spandrel posts are made with pairs of built channels latticed together and tapering in both directions from bottom to top. They have longitudinally extended bases riveted to the cover plates of the top chords through inclined connection flange angles, and have gusset plate connections to sway-brace struts and diagonals, both made with pairs of channels latticed.

The 72-inch lattice-girder floorbeams are web connected to longitudinal girders of the same depth, are 17 feet apart and

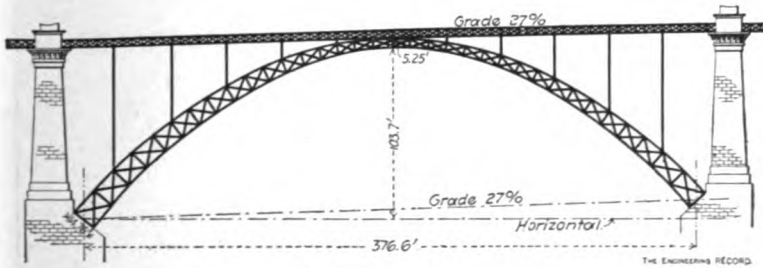

MAIN SPAN OF CORNHOUSE BRIDGE.

have both ends extended by cantilever sidewalk brackets  $7\frac{1}{2}$  feet long. The top flange has an I-shaped cross-section made of a web plate and four flange angles, and the bottom flange has a T-shaped cross-section made with a web plate and two flange angles. The cruciform verticals are made with four angles, back to back, and the X-braces in the four panels between them are made with single channels riveted to the flange webs and to each other at intersections. There are riveted lateral diagonals crossing three panels each in the planes of the top and bottom chords of the arch trusses.

The ends of the chords are riveted to solid steel bearing castings with plane surfaces seated on cast steel pedestals anchored by long bolts tangent to the arch curve and screwed up against reaction beams, accessible from inspection chambers in the masonry. The shoes are adjustable transversely and in their distance from the ends of the chords, by sets of double wedges which were locked after the adjustments were made. The bridge has a solid steel floor, which for the sidewalks is composed of longitudinal rolled troughs, filled with concrete and surfaced with asphalt, and for the roadway is composed of galvanized  $\frac{1}{4}$ -inch buckle plates, convex side down, concreted and paved

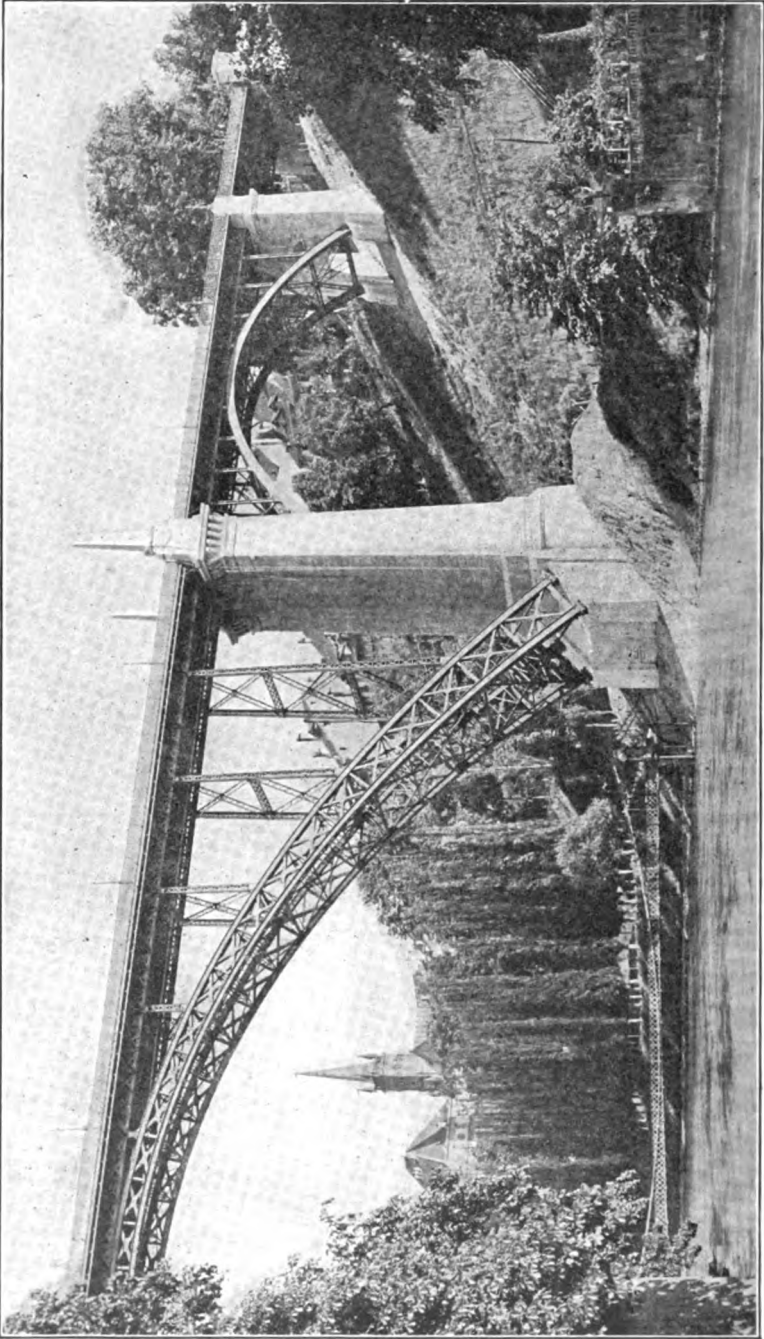

HALF OF 36 1/4 FOOT MAIN SPAN AND APPROACH OF CORNHOUSE BRIDGE.

with wooden blocks. The bridge was calculated for a live load of 90 pounds per square foot of floor surface, and for 30 pounds wind pressure, and the main span weighs about 1,982,000 pounds.

It was erected on frame trestle bents braced in pairs to make alternate towers and openings, and having an extra wide opening with inclined bents on each side for navigation through the center. The falsework was peculiar in being covered with a solid plank platform convex to correspond with the intrados of the lower chords. Above it an upper story was carried up to the height of the top chord, and provided outside tracks for two traveling erection gantries, with hand windlasses moving transversely to the bridge axis to assemble truss members.

Material tracks outside the trusses were also spanned by the gantries. The pier foundations were on bad ground, and were very difficult and costly. The tall and massive piers were lightened by seven stories of interior chambers, with arched floors and roofs, which were concealed by solid face walls. The piers were chiefly of concrete, faced with granite, and were built with overhead horizontal frameworks covering them, and carried up with the masonry to afford trolleys for handling materials.

The Paderno viaduct over the Adda was described in "The

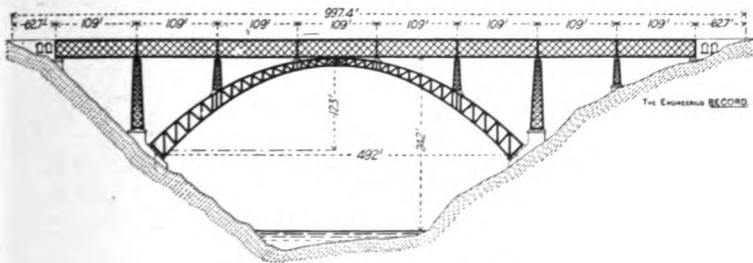

PADERNO VIADUCT, ITALY.

Engineering Record" of October 13, 1888, and in "The Engineer," London, April 17, 1903. It has a center span with two riveted parabolic arch ribs, about 492 feet long and of 129 1-3 feet rise on the center line, which are battered about 1.6 so as to be 56 1/4 feet apart at the skewbacks and 16 1/2 feet apart at the crown. These ribs are each composed of two twin trusses, 3.28 feet apart on centers, which are divided by vertical posts into 34 panels of unequal length, with single diagonal members. The trusses have no hinges and the ends of both top and bottom chords are seated on the normally inclined surfaces of the skew-

back piers, which also receive the bases of the skewback tower separate from the arch trusses. The T-shaped chords are built of angles and plates, and the adjacent vertical members of each pair are united by latticing. There are lateral X-brace systems in the planes of top and bottom chords of the horizontal and arch trusses.

The arch ribs support two main vertical towers at the haunches, each of which is composed of four posts battered longitudinally and transversely and latticed or X-braced together

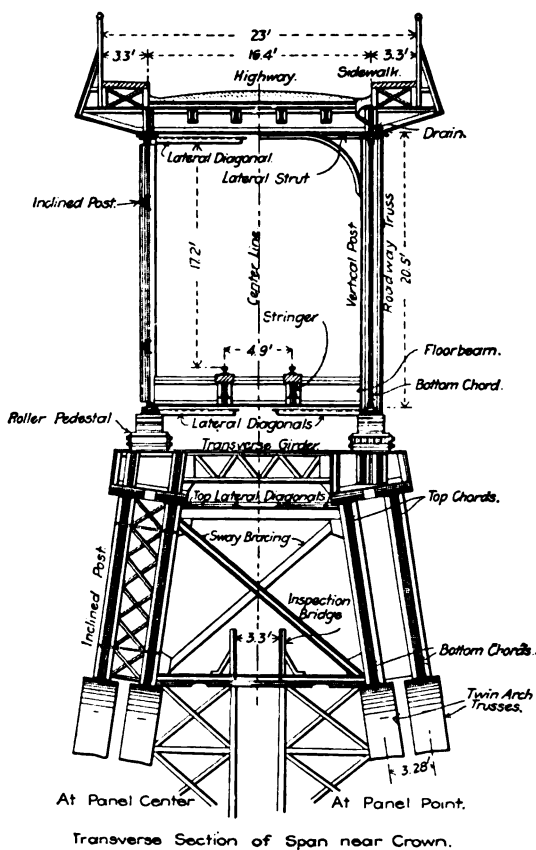

on all faces. The posts extend across the trusses from bottom to top chords and rise to the level of the crown. These towers, with two skewback towers and two short bolsters on the top chords, near the crown, support the five 109-foot through spans of lattice-girder roadway trusses. These carry a single-track

railroad at the level of their bottom chords, and a 23-foot deck carriageway and two cantilever sidewalks at top chord level. An inspection foot walk is also carried by the lower lateral system in the center line of the bridge.

The roadway trusses, 20 feet 4 inches deep and 15 feet apart in the clear, have T-shaped angle iron chords connected by T-shaped quadruple intersection web members. The lower deck, 242 feet above water level, has a solid corrugated iron floor on U-shaped joists, and single-track rails laid on oak timbers on the longitudinal stringers. The upper deck, supported on four lines of stringers carried by floorbeams 10 feet apart, on the top chords, has a macadam pavement.

The bridge is constructed throughout of wrought iron with an ultimate strength of 43,000 pounds per square inch, and a maximum total unit working load, including wind and temperature stresses, of 7200 pounds. The weight of the arch span is 1320 tons, and the bridge was completed within eighteen months. The total computed loads carried by the main span at the four intermediate points, are 299, 255, 252 and 309 tons, and the arch stresses were calculated from these values and from an assumed wind pressure of 167 pounds per linear foot. The live loads were assumed to be 1.55 and 1.2 tons per linear foot from the railroad and highway floors respectively. Three tests were made and the results announced to the recorder through speaking tubes. In the first test, gravel to a weight of 1.2 tons per foot was spread uniformly over the whole length of the bridge; in the second test six 83-ton locomotives were placed on the span, and in the third test a 600-ton train of three 83-ton locomotives and 30 cars of gravel, was run several times across the span at a speed of 28 miles an hour. The maximum crown deflection was  $\frac{3}{8}$  inch, and the maximum lateral vibration 3-16 inch.

The bridge was erected in ten months, on a timber falsework of unusual design, with horizontal service platforms at water level, at skewback level and at the crown of the top chord. The two lower tracks each spanned openings of 153 and of 65 feet, above which the falsework bents were carried on combination trusses and on inclined bents and corbel brackets. The lower chords of the arch trusses were assembled on a convex platform above which vertical bents nearly 30 feet apart were carried up between the haunches to support the upper platform. The pier towers and approach spans were erected with falsework towers supporting corbel brackets and temporary deck spans, on



which the erection platform and upper service track were carried. The trusses were assembled by two 15-ton jib derricks moving on gantries having A-shaped end towers. The gantry trusses cantilevered beyond the towers and carried hand windlasses on the overhangs to hoist materials from the service tracks. Each falsework bent was seated on the cap of a transverse row of seven piles, and had six batter posts 10 panels, or 241 feet high at mid-span. The two center posts intersected about 100 feet from the bottom, and carried a single vertical post on their heads. There was a double

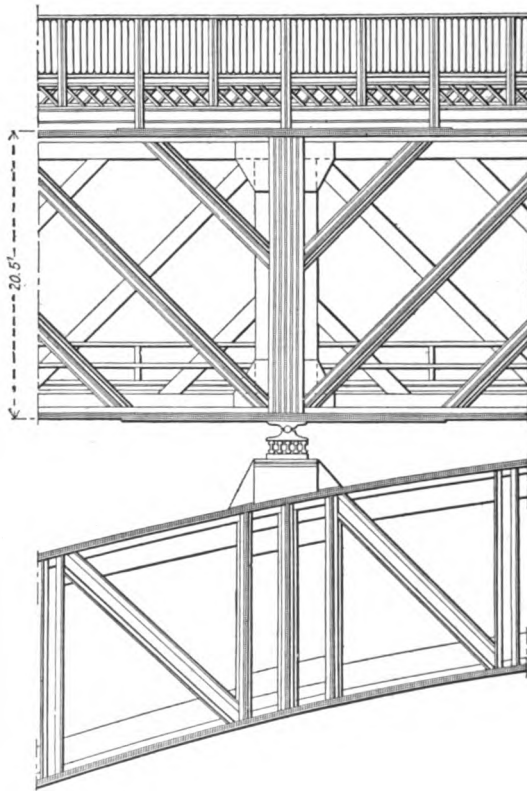

Support of Roadway Girders on Arch Truss near Crown.

The Construction of Bridges

longitudinal horizontal timber at each intersection of the batter posts and horizontal struts at every story, and every panel of the outer faces of the falsework was braced by a longitudinal diagonal strut. The lowest service platform was through the center of the bents just above the first cross timber on the batter posts.

The Eads Bridge across the Mississippi River, at St. Louis, was built about thirty years ago, and was notable for being the first steel arch bridge, for its unprecedented span, for its great cost, for the difficulties of construction and erection, for the peculiarities of its design, and for the character of its details, which required unusually accurate and careful workmanship. The superstructure stands as a remarkable example of elaborate and difficult bridgework. It is unique, for it has not been, and never will be, followed as a type for other bridges.

It has three main spans, one of 520 feet over the channel, and one of 502 feet on each side. Each span has four hingeless segmental trussed arch ribs with a radius of 742 feet. The trusses are in vertical planes, and each has parallel top and bottom chords 12 feet apart on centers with a triangular system of pin-connected web members. The center span has 44 truss panels and a rise of 47 feet for the top chord; the side spans have a rise of  $43\frac{3}{4}$  feet and

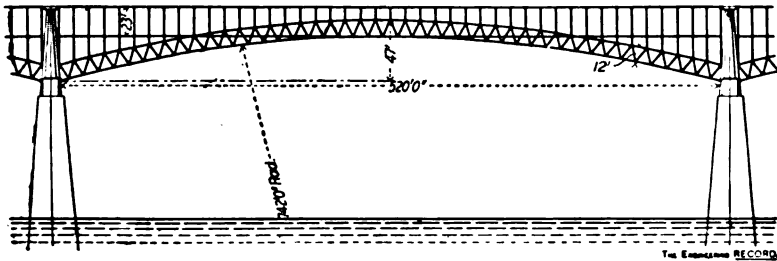

EADS BRIDGE, ST. LOUIS.

42 panels. The width of the bridge over all is 54 feet, and the height in the center above low-water mark is 144 feet. The total cost was about \$10,000,000.

Each of the inner ribs is 6 feet from the longitudinal center line of the bridge, and each of the outer ribs is  $22\frac{1}{2}$  feet from it. The horizontal roadways are carried on vertical posts seated at panel points on the top chords of the trusses. The trusses are connected together by top and bottom transverse struts and by transverse sway-bracing diagonals, in the planes of the inclined web members. The vertical posts are connected in pairs by transverse horizontal struts and diagonal rods, and there are lateral braces in the floor systems. The truss chords are cylindrical, 18 inches in outside diameter. Each section, about 12 feet long, is made of six high-steel, machined staves, enclosed in a thin steel jacket, forced on under heavy hydraulic pressure.

The machined ends of the chord sections abut, and are connected by heavy steel sleeve couplings, made in two pieces each, flange bolted together. Transverse rings on the inside of the

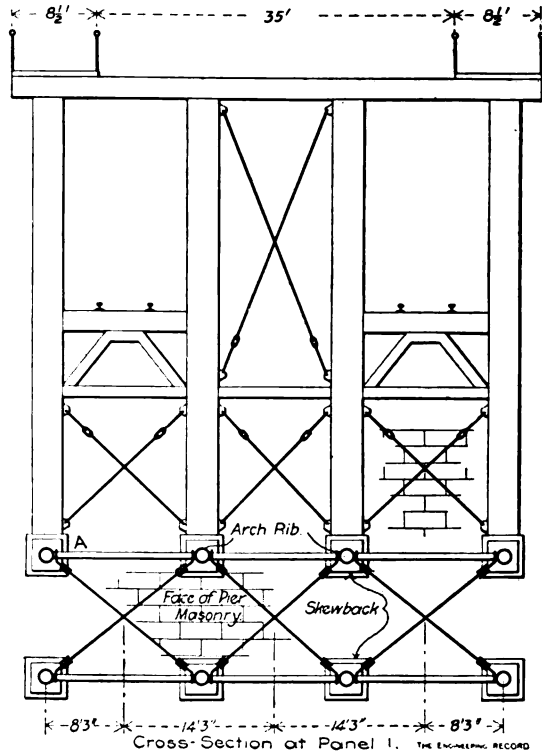

coupling fit corresponding grooves turned in the ends of the chord sections. The pins pass through the centers of the chord joints and couplings, and engage the diagonal truss members and the jaw plates on the lower ends of the vertical posts. They are peculiar for having a reduced center diameter between bearings. The diagonals are made of pairs of very wide eyebars with circular heads, and are stiffened by tee bars riveted to their inner faces and connected by lattice bars. On the inner sides of the trusses the pins are prolonged to engage bent wing plates, which have double fish-plates, with a pair of secondary pins for the connection of each lateral and sway-brace rod. Beyond these plates the end of the pin screws into a coupling piece in the end of the pipe which forms the transverse strut. There are for each span sixteen skewback castings recessed into the pier masonry and secured to those of the

adjacent spans by anchor bolts reaching through the piers. The chords have long square threaded screw bearings in the skewback castings.

The two railroad tracks are carried between the outer trusses and are approximately tangent to the lower chords at the centers

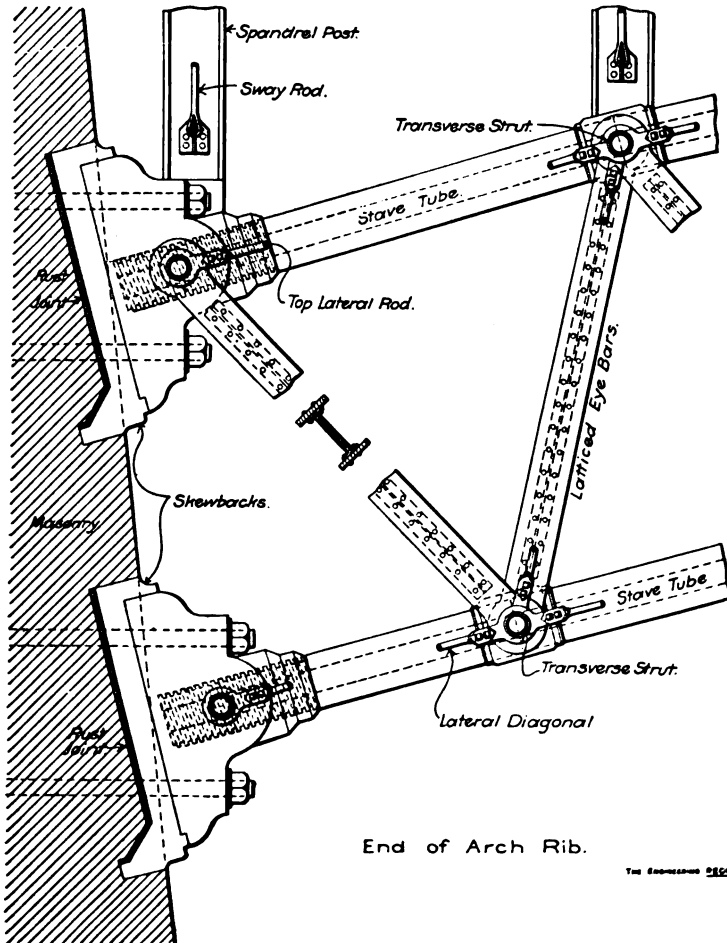

of the spans. There is a deck platform 21 feet high in the clear above the rails, which is 54 feet wide over all, and has a 35-foot driveway in the middle, and two 8½-foot sidewalks.

The trusses were erected by the guyed cantilever method, the adjacent ends of both spans being simultaneously erected, with balanced reactions on the opposite sides of each river pier. All

four trusses of each span were erected together for about one-quarter of their lengths from the skewbacks, and then work on the

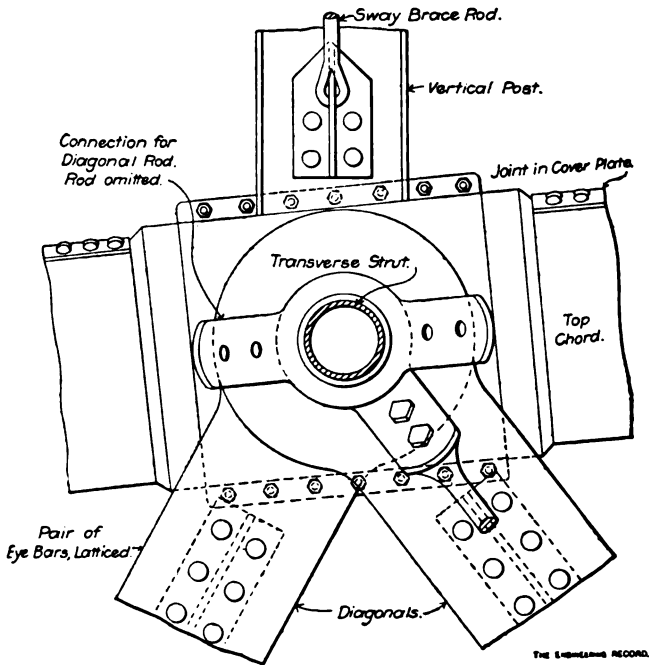

Side Elevation of Joint.

side trusses was discontinued until the center trusses had been completed and were self-sustaining and served as platforms from which the former were erected. The cantilever ends of the trusses

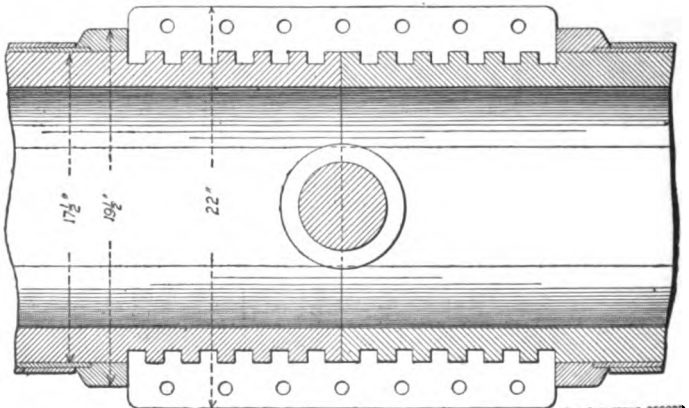

Sectional Elevation of Chord Coupling.

were supported at successive panels by multiple wire rope guys carried over wooden falsework towers seated on the tops of the masonry piers on special hydraulic presses, by which they could be raised and lowered to adjust the positions of the trusses. The guy cables were supported over the cantilevered trusses by elaborate falsework bracing, and were anchored at the west end to castings at the feet of wells cut 30 feet deep in solid rock. At the east end the guys were fastened to the middle of a 48 x 48-inch built oak beam bolted across four rows of 12 x 12-inch sheet piles driven in

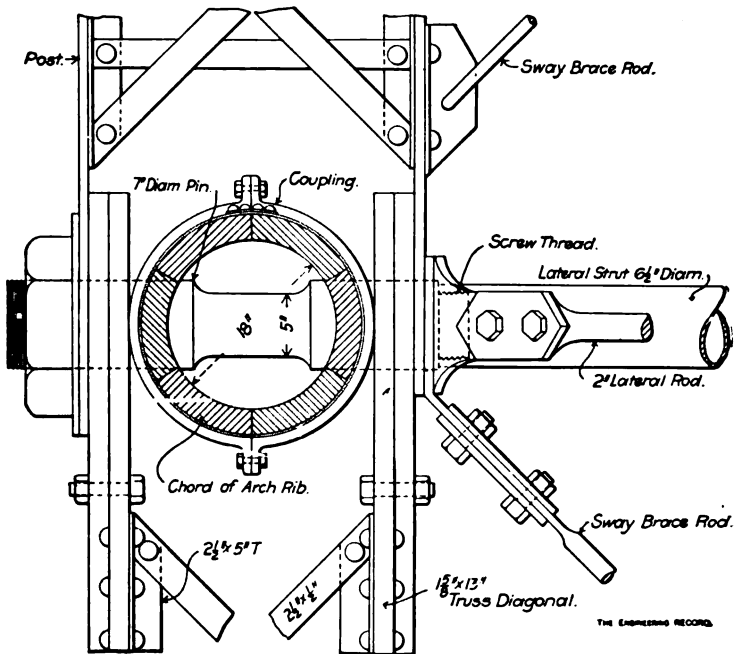

Sectional Elevation at Top Chord Panel Point.

the bottom of a pit 30 feet deep back-filled with rammed sand. The middle guys had a tension of 432,000 pounds each, and the outside ones 216,000 pounds each. The arch trusses were closed with great difficulty in hot weather, when the expansion of the steel ribs reduced the space in the center panel so that there was not sufficient clearance for the last chord sections. Troughs were built around one of the chords and packed with ice and finally the chord section had to be cut shorter than the computed normal length.

## CHAPTER XI.

### **KAISER WILHELM AND GARABIT BRIDGES. SPANS 525 AND 541 FEET.**

The double-track Kaiser Wilhelm Bridge across the Wüpper River at Müngsten, Germany, was illustrated in "The Engineering Record" of June 10, 1899, and in the "Génié Civil" of July 2, 1898.

Its construction was seriously considered about fifteen years ago when the Douro bridge of 566 feet span was the longest arch in existence, and of the others mentioned only the Garabit, Eads and Washington had been built and could serve as precedents, more or less parallel, for the construction of this great span in a difficult location. The government railway authorities invited the leading German bridge builders to submit designs for three types of structures for crossing the valley at the point selected, where it is nearly 1600 feet wide and 354 feet deep, with good foundation slopes and only an insignificant stream to deal with. One type was a viaduct with steel towers and short connecting spans, another was a viaduct with a large central arch span without a crown hinge, and the third was to have a large cantilever span in the center. The approximate cost had been previously estimated from a preliminary study of a 525-foot span with hingeless arch ribs which carried high level roadway trusses on four spandrel towers. One design was received which consisted of nine 66-foot towers 100 feet apart (the middle one 325 feet high) and double cantilever girders on top of each tower which projected 16 feet each side and supported suspended spans of 68 feet. Another design was for two double balanced cantilever truss spans, whose channel arms met at the crown of a 560-foot pseudo-arch, and whose anchor arms resembled 365-foot semi-arches abutting on the approach masonry at the tops of the banks, making a total length of 1530 feet of continuous superstructure. The third design was for six side spans and viaduct towers and a 525-foot hingeless parabolic-arch trussed center span carrying horizontal high-level roadway trusses from its crown and skewback towers. The last plan was accepted and constructed.

The viaduct consists of four steel towers battered transversely only, which are 49 feet wide and support three 98-foot and three 148-foot riveted triangular-truss deck spans. Each tower has four columns, and each face is divided vertically in 40-foot panels by horizontal struts. Diagonal struts two panels in length intersect at the centers of the alternate horizontal struts, and in the horizontal plane of each set of struts, four more struts form an inscribed rectangular with its angles at the centers of the main struts. There is also a transverse strut connecting the middles of the longitudinal struts at each panel, and it is supported at the center, as are the other struts, by auxiliary suspenders from the panel points above.

The main span has two hingeless arch trusses, in battered planes, which carry the roadway trusses on skewback towers and

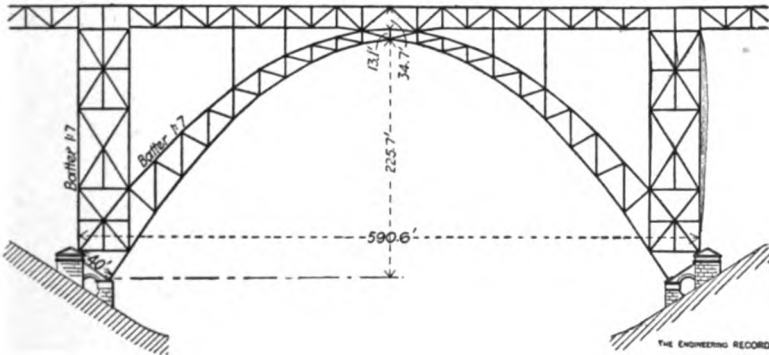

KAISER WILHELM BRIDGE.

vertical spandrel rocker bents. The eccentric parabolic top and bottom chords have spans of  $590\frac{1}{2}$  and 525 feet and rises of 225.7 and 238 feet, respectively, and are 40 and 13 feet apart at skewback and crown. Each truss is divided by vertical posts into 22 equal panels with single diagonal braces. There is a horizontal transverse strut at every top and bottom chord panel-point and the panels between them are X-braced in lateral and sway systems. The chords have rectangular cross sections made of pairs of built channels with reinforced flanges, latticed with angles.

The skewback bearings are solid riveted shoes seated on the inclined surfaces of massive masonry piers, made in two parts connected by arches. The posts of the skewback towers and spandrel rocker bents form parts of the vertical posts of the trusses, and are continued across them to the bottom chords.



The opposite columns of the main towers have their bases riveted to web connection plates on the upper sides of the lower chords of the main trusses at the second panel points. The towers all terminate at the lower chords of the viaduct spans, and between

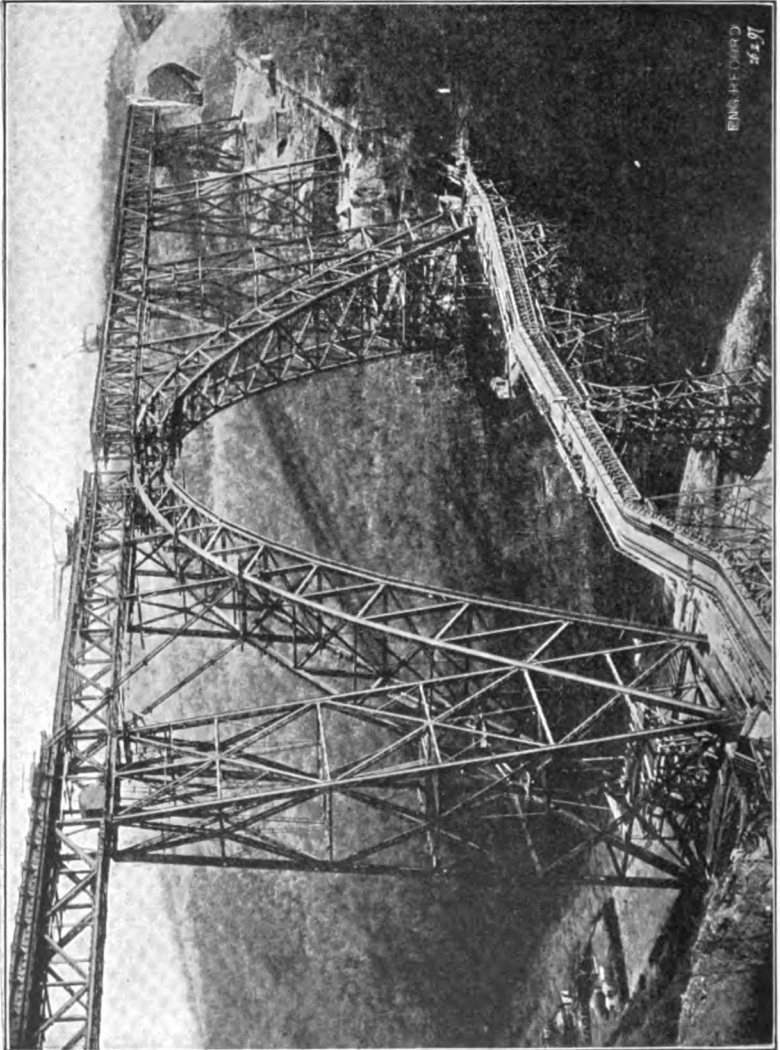

KAISER WILHELM BRIDGE, MUENGSTEN, GERMANY. CLEAR SPAN, 426 FEET.

the skewback towers there are roadway trusses of uniform design with the short spans so as to form apparent continuations of them. They are directly supported from the arch at two panel points at the crown and by rocker bents at two intermediate points

on each side. The roadway trusses have transverse and top and bottom lateral diagonal bracing and are in vertical planes, while the arch ribs and tower posts have a transverse batter of one in seven. All members are stiffened, and all connections are riveted. The compression members have rectangular cross-sections, generally made up of two built channels latticed together, and the transverse and lateral struts are tapered at the ends. The roadway trusses are riveted together continuously to form three sections, the center one terminating at the inner faces of the two main towers. Each section is fixed at the middle point and supported on rollers at the other bearings so as to allow for a temperature variation of about 8 inches in length.

The roadway trusses are latticed girder spans, continuous between the inner faces of the skewback towers, where they have expansion seats. They are nearly 35 feet deep and 16 feet apart, and are supported intermediately at the crown and on the spandrel bents. They have top and bottom diagonals and sway bracing, and are in vertical planes, while the arch trusses are battered 1:7 so as to be 84 feet apart at the bottom. The double-track roadway has a solid floor with narrow sidewalks cantilevered outside the trusses at a height of about 350 feet above the water. The roadway is cantilevered a little beyond the arch ribs on both sides so as to receive the double tracks. The total length of the steel superstructure is 1525 feet. Under a test load of 80 loaded cars with three locomotives in the middle of the train, the center deflection of the finished span was about 6 inches. The weight of the main span and approaches is over 5600 tons, and the cost was \$687,500.

Extensive shops were established near the top of the bank at one end of the bridge.

In erection all material was delivered at one end of the bridge where extensive shops and yards were established near the top of the bank. Over 13,000 cubic yards of clay were excavated to secure a level surface of about 81,000 square feet for the material yards, power plant, shops and offices, all being located together on the Solingen side of the valley. A well was sunk at the bottom of the valley near the river bank, and water for the boilers and other purposes was pumped from it to a reservoir 377 feet above the river and 26 feet above the yard. Two dynamos with a total power of 23 kilowatts were installed to furnish light and power, and from them all the plant was operated. From the yard a service track was run alongside the bridge from end to end.

This consisted of a single-track inclined plane down the slope to the level of the top of the skewback piers about 240 feet below grade. It was parallel to the bridge axis and 66 feet from it, and a similar inclined plane and track was built on the opposite slope. Between the bottoms of these inclines a temporary level viaduct was built about 110 feet above water level and only 26 feet from the bridge axis. The total length of the viaduct was about 650 feet, and it comprised trestle work at each end, and four main spans of slightly varying lengths, the maximum being about 95 feet.

These spans each consisted of two deep light riveted lattice-girder deck trusses, and were supported by five principal towers, one of which was of steel, and the others of timber. The three tallest ones were built on temporary pile piers, the others on timber sills. From the tops of the adjacent sides of each pair of viaduct towers timber corbel brackets about 25 feet wide were built out, reducing the clear spans between to about 45 feet, which were crossed by pairs of combination queen-post trusses whose top chords and the top pieces of the brackets formed stringers on which a working platform was built for the erection of the temporary service trusses. A double track was laid on this bridge and connected with the inclined single tracks on each side of the river so as to form a distribution line the whole length of the bridge. From it curved spur branches were run between the piers of each tower, and on them were delivered the 18,000 wagon loads of stone and 116,545 cubic feet of mortar required for the masonry. The mortar was mixed dry by machinery on top of the bank and transported in covered wagons to the piers, where it was stored until needed. Each incline was operated by a separate electric hoisting drum and steel cable, which was run day and night, and scarcely sufficed to distribute the large amounts of materials required. The steel members were delivered from the tracks directly to the hoisting derricks, and were transported on special cars with bolsters pivoted on the axles to swing both vertically and transversely; the long ones required bolsters of different heights at the opposite ends of the car so as to level them up on the steep inclines, and therefore these cars had to be reversed after descending one incline before ascending the other.

The superstructure was erected from both ends of the viaduct toward the center simultaneously. All of the towers were first erected in the most costly and elaborate way possible by building inside of them to their full heights massive temporary

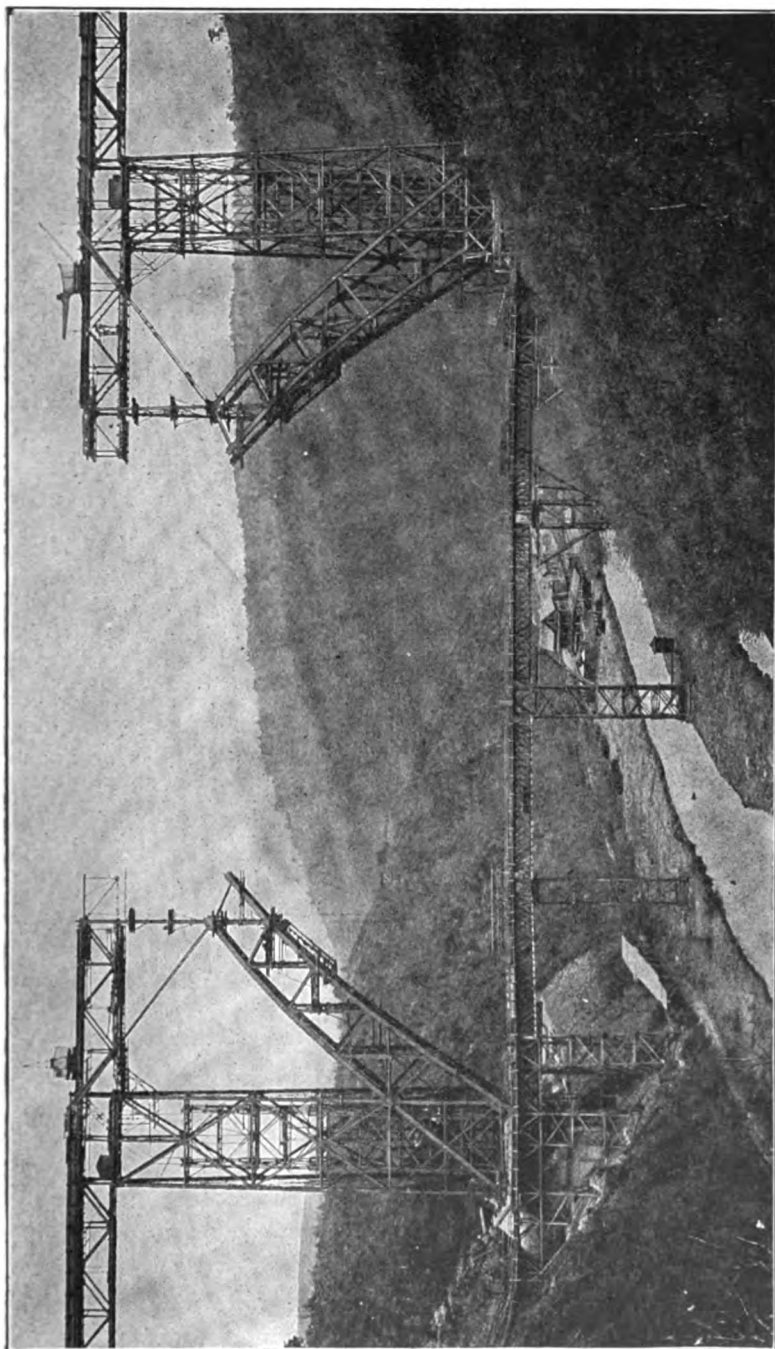

ERECTION OF KAISER WILHELM BRIDGE, TEMPORARY SERVICE. BRIDGE AT SKEWBACK LEVEL.

timber towers, from which the separate members of the permanent towers were handled. The skewback falsework towers were made of square timber, and had double posts at each corner. These posts were spaced a few inches apart, with their diagonals in line so that the ends of the X-brace plank in every panel of each face passed between the pieces, parallel to their faces, and were bolted to each. The falsework towers were divided vertically into twice as many panels as the permanent ones, and at each panel a solid timber working platform was built. The splices of the tower posts did not break joints, and the separate lengths were raised and assembled by ordinary gin poles or booms. The steel members were apparently lifted by tackle suspended from cross beams in the outer faces of the tower which were supported from cantilever beams resting on the cross struts. The hoisting apparatus was carried up, panel by panel, as the erection progressed, and on the top of the finished falsework tower a balanced revolving trussed horizontal arm is seen which was apparently used as a kind of overhanging derrick for the smaller members.

After all the towers were completed the connecting spans between them were built. The end spans, which were not very high above the surface of the ground, were erected in position on ordinary trestle falsework, but those near the center span were at such a great height that falsework for them would have been very expensive. They were erected on elevated platforms built on the top chords of light steel trusses which were assembled in complete spans and hoisted bodily by tackles suspended from overhanging beams to seats on steel cantilever arms built out about 35 feet from the sides of the towers so as to reduce the clear spans to about 80 feet. After the spans were all completed from the abutments to the tops of the skewback towers they were continuously riveted together, and their chords thus developed sufficient strength to anchor the roadway and arch trusses back to girders bedded in concrete masonry in excavations quarried out of the solid rock. This was done by running two pairs of steel cables from the top of each end tower to the anchor well, where they took screw bearings on pairs of steel beams. At the upper ends of these cables similar screw bearings engaged beams which were adjustable by hydraulic jacks in a yoke riveted to the top of the tower.

The horizontal roadway trusses were first built out, panel by panel, cantilever fashion, from the tops of the towers by loco-

motive revolving derricks, and as they were extended formed a platform from which the same derricks hoisted and assembled the members to form the successive panels of the arch ribs, which were kept a little back of those of the upper trusses. After the first four panels of each arch truss had been built out from the skewback, the permanent vertical and a temporary diagonal were built from the upper end of each and connected to the roadway spans, thus relieving the excessive erection trusses. From the fourth panel upward the arch trusses were completed by simple

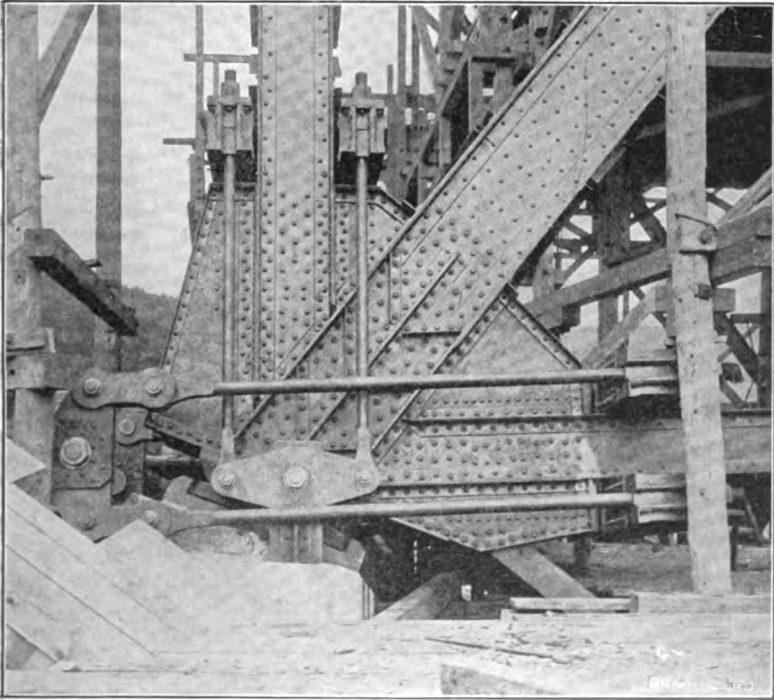

TEMPORARY SKEWBACK ADJUSTMENT.

cantilever construction without additional backstays. When the crown panel was reached hydraulic jacks were set between the adjacent ends of the top and bottom chords of the arch ribs, and were extended until they revolved the semi-arches about the upper chord skewbacks and relieved the pressure on the temporary shims, which had been set under the lower-chord skewbacks to tip the towers 8.4 inches back at the top and compensate for the erection deflections of the trusses and towers. The shims

were removed and the jacks slacked off until the ends of the crown sections of the lower chords engaged and were riveted up. Then the top-chord joints were riveted and the strains and bearings at the skewbacks were measured and adjusted by special hydraulic mechanism. After the completion of the permanent bridge the spans of the low-level service bridge were bodily lifted from their towers by tackle suspended from the new structure, and were lowered to the ground and dismembered. The erection of the bridge occupied twenty-two months, and the total cost of the completed structure was \$687,500.

In order to facilitate inspection, painting, repairs, etc., four maintenance travelers have been provided for different parts of the structure, and two of them are duplicate ones for the horizontal roadway trusses. Each has a pair of vertical struts in the same transverse plane, which roll on double longitudinal trolley rails under the cantilever ends of the floor beams. Their bottoms engage guides projecting from the lower chords of the trusses, and to their lower outside corners are pivoted at their middle points the upper chords of light lattice girders, which, when revolved up into a horizontal position, meet and are locked together at the center under the span, and, with the side struts, completely enclose the bottom and sides of the trusses, and run back and forth on them between the center and ends, giving access to all parts of those surfaces. When the arch verticals are encountered the bottom semi-girders are unlocked at the center and revolved into vertical positions when they clear all obstructions, and can be taken past them and reunited on the other side. The insides of these trusses are reached from a small car which travels unimpeded from end to end of the structure on rails laid across the lower horizontal struts and clears the A-shaped transverse bracing. It carries a pivoted adjustable and telescopic ladder which reaches all parts of the interior. The intrados of the main arch truss is reached from a foot bridge which consists of two light transverse lattice girders suspended at their ends by chains from trolleys running on the same tracks that serve the platform travelers; the chains are adjustable by hand and windlasses on the bridge, which raise or lower it to correspond to the curve of the intrados.

The Garabit viaduct, a single-track railroad structure across the Truyère River, France, was described in "The Engineering Record" March 7, 1891. The center span combines greater length and height than any other bridge of the same type, and is

remarkable for this and for slender proportions and conspicuous position. The center span has a pair of two-hinge lune-shaped arch trusses in battered planes. The top and bottom chords are eccentric parabolic curves with a common chord of 541.3 feet, depth of about 33 feet, and rise of lower chord of about 166 feet. The trusses are inclined 11:100 from the vertical and are divided by vertical members into 29 unequal, X-braced panels. They are about  $65\frac{1}{2}$  feet apart at the skewbacks and  $20\frac{1}{2}$  feet apart at the crown, and are connected by transverse struts at all panel points and diagonal braces in the planes of the top and bottom chords and vertical posts. The lateral diagonals make angles of approximately 45 degrees with the chords, so that near the ends of the trusses they extend across two panels and have triple intersections; in the middle of the span they extend across single panels only.

The web members of the trusses are stayed by a curved line of longitudinal struts through their center points; midway between the top and bottom chords. The chords have rectangular trough shaped cross-sections latticed with angles on the inner

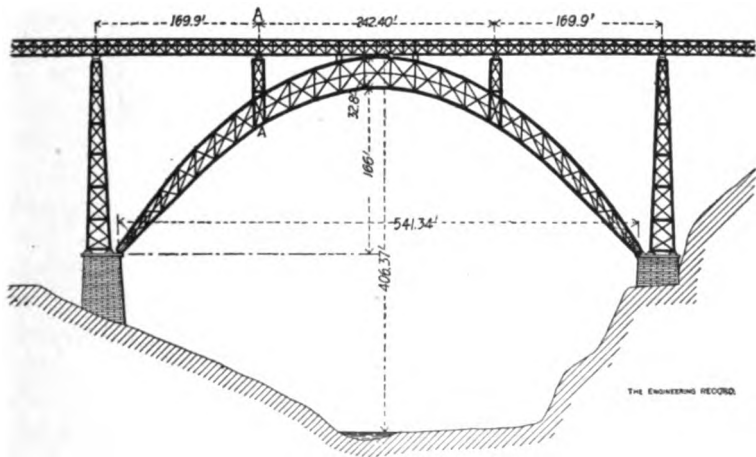

THE GARABIT VIADUCT.

sides. They are uniformly  $25\frac{1}{2}$  inches wide and  $23\frac{1}{2}$  inches deep except in the end panels where the top and bottom chords have common web plates making a deep closed box-girder section. The web members have I-shaped cross sections made with pairs of angles riveted together back to back, latticed, and riveted at the ends to the chord webs. The intersecting diagonals have the



flanges of their angles turned in opposite directions so as to clear at intersections and rivet on opposite sides of the chord webs at the ends. The rounded ends of the trusses are about 7 feet deep and the chord angles and the center line strut angles converge to afford bearing for the semi-cylindrical hinge about  $11\frac{1}{2}$  inches in diameter and  $2\frac{1}{2}$  feet long. This is seated in a concave bearing block with a slightly larger radius, which is flat on the opposite side and engages a cast-iron pedestal on which it is adjusted by pairs of wedges between top and bottom flanges, as shown in the detail.

The pedestals are seated on the chamfered upper corners of mas-

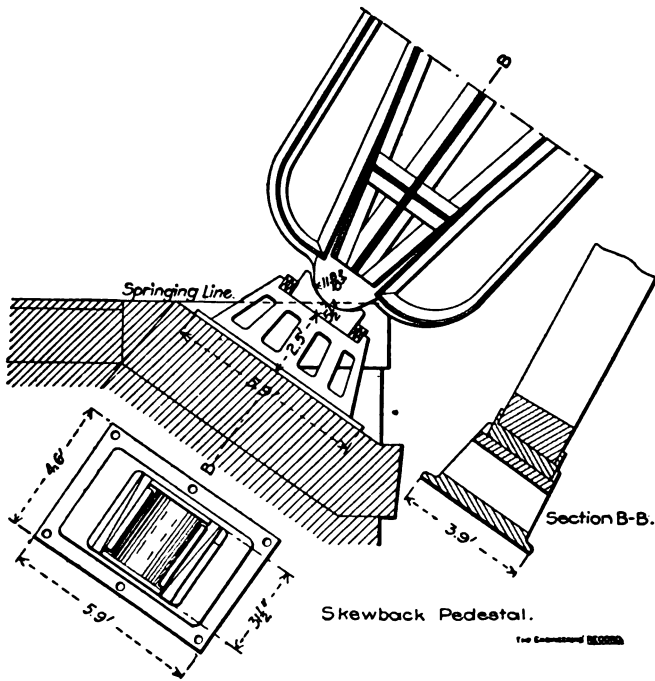

sive masonry piers about 37 feet wide and 82 feet long on top. The piers are battered 4:100 longitudinally and 12:100 transversely and have separate footings connected by a longitudinal full-centered arch of about 20 feet radius. The trusses are anchored to the piers by a pair of rods at each end of each truss tangent to the center line of the truss. The rods are in vertical planes and their upper ends engage the opposite sides of a rocker bearing plate across the top flange of the end lateral strut. They clear the pedestal and, entering the

pier on a diagonal line, pass through a narrow inclined well to a chamber under the center of the tower, where they have cotter wedges engaging a saddle on the under sides of reaction beams built into the arched roof of the chamber. The spandrel posts are parallel to the truss vertical posts and extend across the trusses from bottom to top chords. In each haunch there are four, battered in both directions and braced on all faces to make a tower which has longitudinal and transverse girders across the tops of the posts and supports the roadway trusses on expansion pedestals. The roadway trusses are about 17 feet deep and  $16\frac{1}{2}$  feet apart, and are continuous lattice girders in vertical planes. They carry a single-track railroad about half way between top and bottom chords and a footwalk at lower chord level which is on the center line of the bridge and passes through the sway bracing, clearing the diagonal members. The skewback towers are about 201 feet high, made with four posts, battered transversely and longitudinally. Transversely they correspond to the inclinations of the arch trusses, and longitudinally they are 23 feet long at the bottom, and about 9 feet long at the top. Each post has an anchor rod  $28\frac{1}{2}$  feet long engaging a reaction beam built into the pier masonry, and there is a spiral staircase inside each tower affording passage from ground level to the roadway. The tower is divided into six equal stories by horizontal transverse and longitudinal struts and each vertical panel is braced with two panels of X-braces, besides which there are horizontal X-braces at each story.

The wind pressures were assumed at about  $30\frac{1}{2}$  pounds, and 55 pounds per square foot for loaded and unloaded trusses, and on 5.3 square feet of train surface per linear foot. The maximum combined wind and train loads produce unit stresses of about 8534 pounds per square inch, and the maximum temperature stress is about 900 pounds per square inch. The calculated deflections for live and dead loads at the crown are 1.37 and 0.65 inches, plus 2.05 inches for a fall of 30 degrees Centigrade in the temperature. The lateral displacement at the crown from wind pressure is calculated to be 0.93 inch. The weight of the main span, three land towers and three 182-foot spans and two 170-foot spans similar to those above the arch trusses is about 7,333,500 pounds, and its cost, including about 24,400 yards of pier masonry, about \$620,000.

The building of the masonry and the erection of the superstructure was facilitated by the initial construction of a \$4,000 service bridge 25 feet wide, over 100 feet high and nearly 500 feet

long across the river, under the main arch span. It was built with framed trestle bents about 40 feet apart with knee braces dividing the stringers into three nearly equal parts. The land towers were built up from the bottom and their viaduct spans were erected on shore and successively connected together in continuous trusses

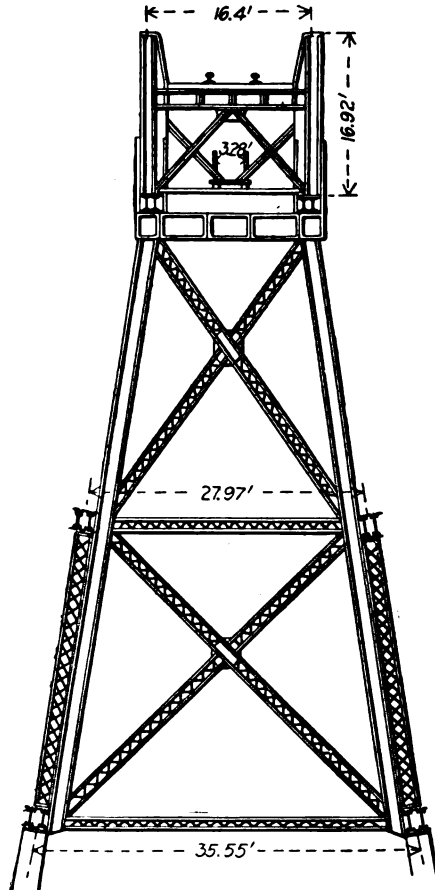

Transverse Sectional Elevation of A-A.

The ENGINEERS RECORD.

and launched forward horizontally on rollers until they were projected from the abutments to a few panels beyond the tops of the skewback towers, when the shore ends were each anchored to the approach masonry by 28 steel cables. The first two panels at each end of the arch trusses were erected on falsework. All materials were delivered on the service track nearly 100 feet below

the springing line, and the remainder of the arch trusses were erected by revolving locomotive hand derricks on the roadway trusses and by trolley hoists on cableways stretched between two temporary wooden towers on top of the skewback towers. The arch trusses were guyed back to the tops of the skewback towers by 24 steel cables, the ends of which engaged reaction beams at the tower top and the bights of which engaged cylindrical bearings on the truss. They were adjusted by hydraulic jacks. The center panel connections were made without difficulty, and the erection was accomplished in about four years.

## CHAPTER XII.

### THE BONN, DUESSELDORF, STRAUBING, WORMS, HARBURG, GRUENTHAL, LEVENSAU AND DOURO BRIDGES. SPANS 298 TO 614 FEET.

The highway bridge across the Rhine, at Bonn, Germany, was described in the Paris "Genie Civil" of May 20, 1899, and in the London "Engineering" of March 30, 1900. It is a very handsome and imposing structure of large dimensions and graceful design, with three arch spans across the channel, a long span, high level through arch in the center and two symmetrical low level deck side spans, with monumental piers and abutments. Between the trusses there is a 29½-foot roadway with two street car tracks, and outside of them there are two 8¼-foot cantilever sidewalks. The

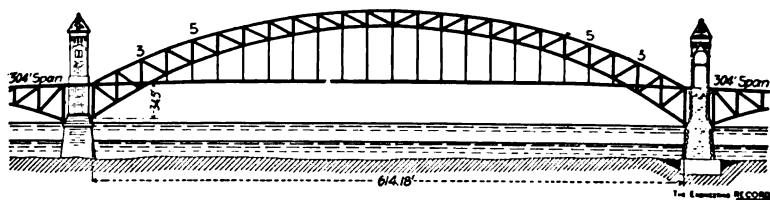

THE BONN BRIDGE, GERMANY.

concrete and wooden pavement is carried on galvanized iron buckle plates, concave side down, supported on lattice girder stringers about 25½ feet long. The floorbeams are plate girders 29½ feet long and 47½ inches deep in the middle, tapering to 39½ inches at the ends and having their webs pierced for drain and gas pipes. The center span has two 614 foot two-hinge arch trusses in vertical planes 29½ feet apart. The top and bottom chords are curved throughout to circular arcs, of 640 and 530 feet radius, respectively. The depths of the trusses are 15 feet 8 inches at the crown and 34 feet 6 inches at the skewbacks. They are divided by vertical posts into twenty-four 25½-foot panels. The rise of the lower chord is 96¾ feet, and its extreme height above mean water level is 137¾ feet. All verticals and diagonals are compression mem-

bers, riveted to the double webs of the chords with pairs of gusset plates having curved edges. The diagonals are made with double pairs of angles latticed, and the verticals with plates and angles built into I-shaped cross-sections. The chords have rectangular

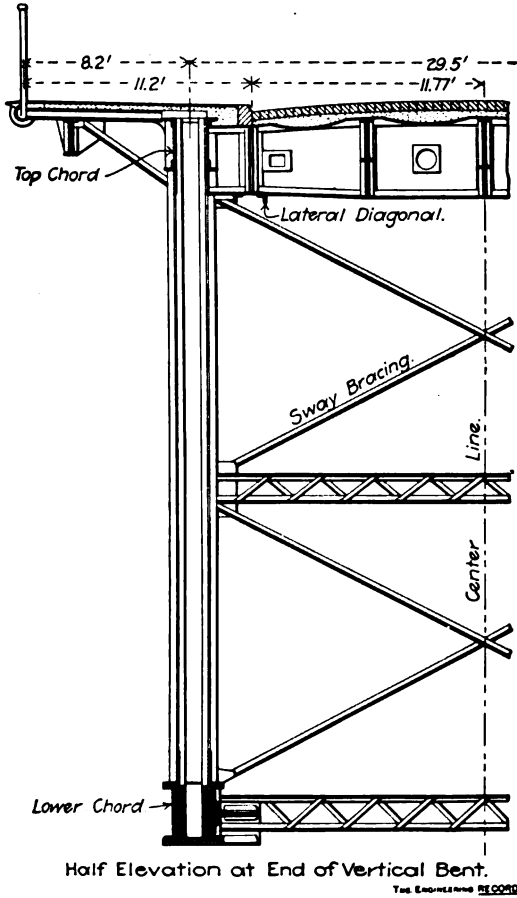

cross-sections made with pairs of built channels and lattice bars or cover plates, arranged in the usual manner, and with peculiar reinforcements, as shown in diagrams of special panels. The chord webs were planed simultaneously to accurate curves on both edges and are made with widths of 20.7 and 10 inches for the inner and outer plates respectively. The top chords are made with  $5\frac{1}{2} \times 5\frac{1}{2}$ -inch angles and have a maximum cross-section of 155 square inches, and the bottom chords with  $6.3 \times 6.3$ -inch angles and a maximum cross-section of 253 square inches. The end

vertical posts and those in the portal bents have extra heavy cross-sections and double pairs of flange angles, and the latter are forked

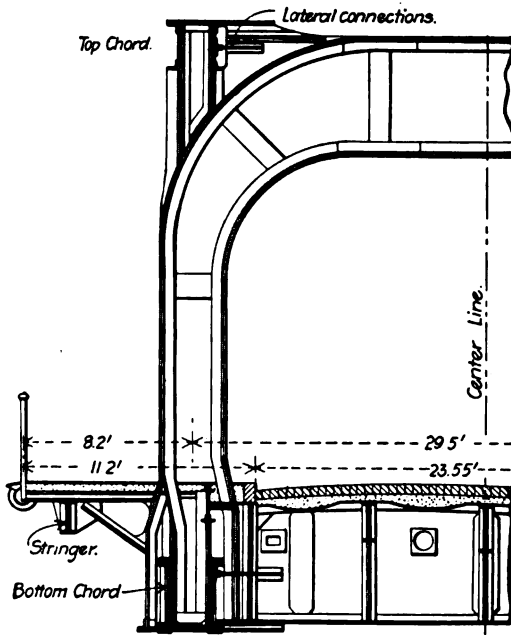

Portal at Panel No.3.

THE ENGINEERING RECORD

and connected to the lower chord transverse diaphragm plates on both sides of each web plate, as shown in the details. The ends of the lower chords have concave flanges engaging cast-steel

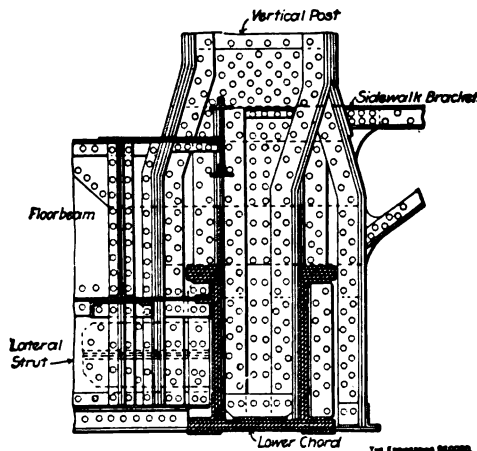

Connections at Foot of Portal.

THE ENGINEERING RECORD

bearings for 10-inch skewback pins  $36\frac{1}{2}$  inches long. The pin has a solid flange or collar at each end, locking it to the cast-steel shoe, which is adjustable with pairs of steel wedges on the sides and bottom with the 10-ton cast-iron pedestal which has a 1-6-inch lead cushion on the granite coping. The 71 x 86.6-inch pedestal base sustains a maximum pressure of about 711 pounds per square inch.

At the ends of the span the floorbeams are web-connected to the chords and the vertical posts. In the middle they pass through and are web-connected to extensions of the vertical posts below

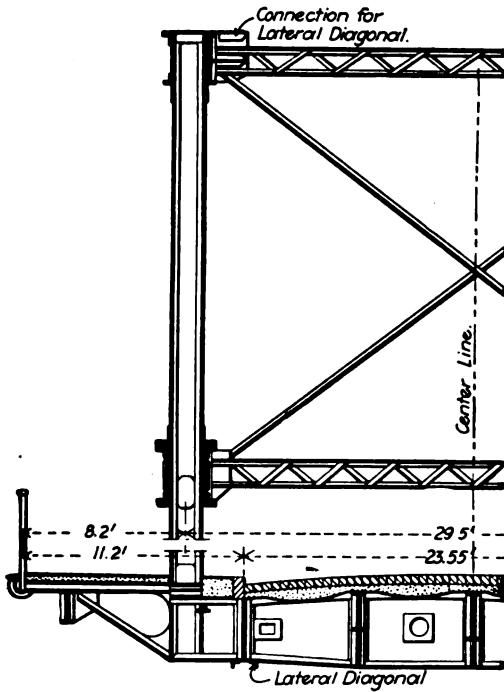

Sectional Elevation at Panel 5.

The Engineering Record

- the lower chords. The floor system is discontinuous longitudinally at its intersection with the lower chords so as not to take horizontal stress from the arch trusses, and at the third panel points from the ends of the trusses there is very heavy portal bracing between the trusses. These connections to the top chords are very rigid, as shown in the detail, and the portal girders are richly decorated with relief work and colors.

There are transverse horizontal struts and X-bracing in all



panels of the top and bottom chords and in the planes or the bottom flanges of the floorbeams, besides the solid buckle plate floor. The transverse struts have rectangular cross-sections, made with four angles tapered towards the ends and latticed on all four sides; the diagonals have I-shaped cross-sections made with two pairs of angles, riveted back to back and latticed. There is transverse sway bracing between the vertical posts in the two end panels under the floor, and at all panel points between the portals there is vertical sway bracing between the top and bottom chords. The bridge was proportioned to carry a 13-ton roller and as many wagons as possible on the roadway, to have the sidewalks filled

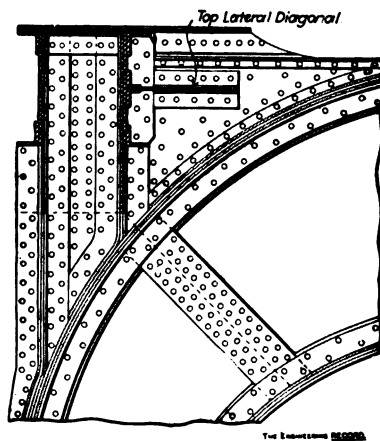

Connection of Portal to Top Chord.

solid with people, and to sustain a wind pressure of 31 pounds per square foot on the surface actually exposed, plus a strip 8½ feet high. The most unfavorable conditions were found to be when the bridge was fully loaded except one sidewalk which was empty, and the maximum stresses allowed were about 18,000 pounds per square inch reduced by compression formulae.

The 69 x 45-foot channel piers were built in cofferdams with double walls 13½ feet apart filled between with puddle. The inner wall was made with vertical I-beams having their webs alternately in its plane and at right angles to it, and driven about 30 feet into the sand and gravel. The outer wall was made of wooden sheet piles about 8 inches thick. A concrete footing about 16 feet thick was deposited over the entire area of the cofferdam through chutes extending to the bottom and moving slowly back and forth on an overhead traveler so as to continuously distribute the sub-

merged concrete without exposing it to washing. The water was pumped out above the footing and the ashlar masonry and concrete backing of the upper parts of the piers were laid by derricks and travelers moving on or spanning the cofferdams and operated by electric motors. Rows of  $\frac{3}{4}$ -inch holes were drilled by electricity through the I-beam sheet piles close to the concrete footings and the tops of the beams were bent back and forth until they broke off and the lower portions were left permanently in position.

The span was erected on pile falsework with bents at panel-

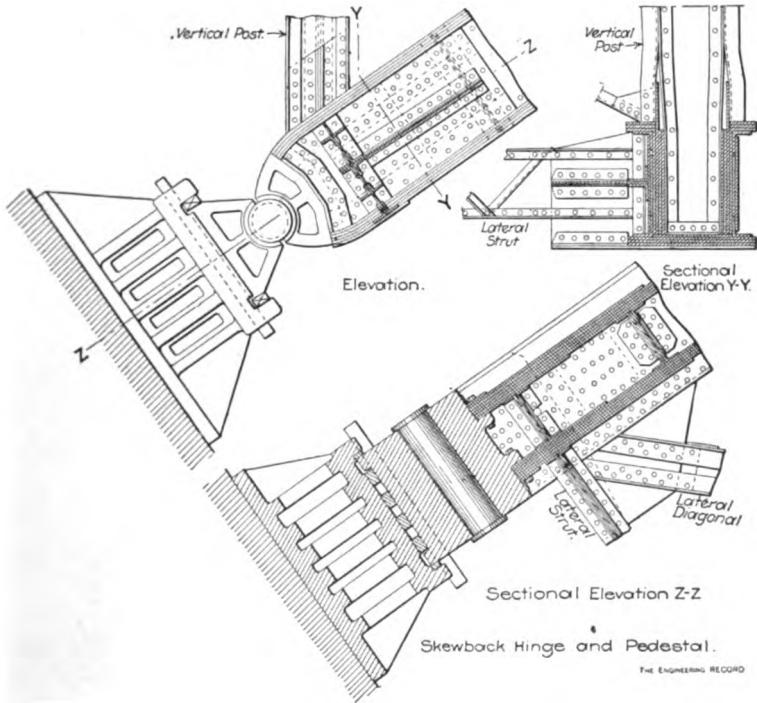

points, reaching to the lower chord level and having two 82-foot openings for navigation. Two rows of vertical posts on each side of each truss supported a horizontal upper platform above the highest point of the top chord, on which two travelers moved and handled all the truss members. These had maximum weights of  $7\frac{1}{2}$  tons and were delivered on boats. The lower chords were assembled on jack screws and were frequently adjusted during erection on account of the settlement of the falsework. The total dead load on the falsework was about 1650 tons and the span was

erected in about twelve weeks, and deflected only  $2\frac{1}{2}$  inches under dead load.

The two 307-foot deck spans have spandrel-braced arch trusses with horizontal top chords at roadway level. The bottom chords are curved to radii of 516 and 416 feet, have a rise of 31 feet, and are 4 feet below the top chords at the center. They were erected in about one month each by methods similar to those for the center span. The bridge was finished in 1898 at a total cost of about \$637,000, and weighs about 3000 tons.

The highway bridge across the Rhine at Düsseldorf, Germany, very closely resembles that at Bonn, and was described in the Paris "Genie Civil," May 27, 1899. It has a total length of 2093 feet, including four short spandrel braced deck arch spans and two channel spans, with a main pier in the center of the river and one on each shore. It has a 27-foot roadway and two 10-foot sidewalks about 62 feet above mean water level. Each main span has two two-hinge arch trusses, 594½ feet long and 32.8 feet apart on centers, from which the floor platform is suspended.

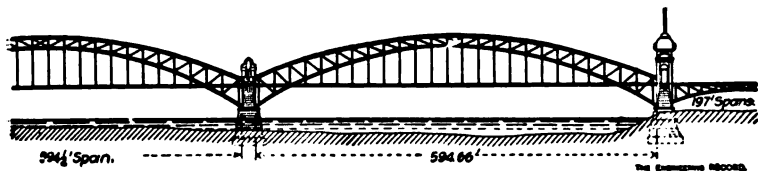

THE DÜSSELDORF BRIDGE, GERMANY.

The top and bottom chords are arcs of eccentric circles in vertical planes and are about  $16\frac{1}{2}$  feet apart at the crown and twice as far apart at the skewbacks. The truss is divided into 25 panels by vertical posts which extend below the lower chords to carry the floorbeams. The trough-shaped top chord has 30-inch webs 19 inches apart made with three plates riveted together, and the cover plate is made with two thicknesses of 32-inch plates. The lower flange angles are reinforced with two  $5\frac{1}{2}$ -inch horizontal plates. The bottom chords are made with two built channels 36 inches deep and 20 inches apart, latticed top and bottom. The diagonal members have rectangular cross-sections made of four angles, latticed on all sides, and the verticals are I-shaped, made with a web plate and four flange angles. There are transverse struts at all top and bottom panel points, between which there is X-bracing in the planes of both chords and in the transverse

vertical planes. There is a third lateral system at the floor level. The floorbeam webs are field riveted between the flange angles of the vertical suspenders and project beyond them to form tapered cantilevers for the sidewalks. There are six lines of roadway stringers unsymmetrically placed with regards to the two street car tracks, which carry buckle plates, concave upwards, filled with concrete and paved with wood blocks. The two lines of sidewalk stringers have their lower flanges projecting below the cantilever floorbeams and stiffened laterally by wide horizontal plates having flange angles on the edges.

The greatest difference between this bridge and that at Bonn

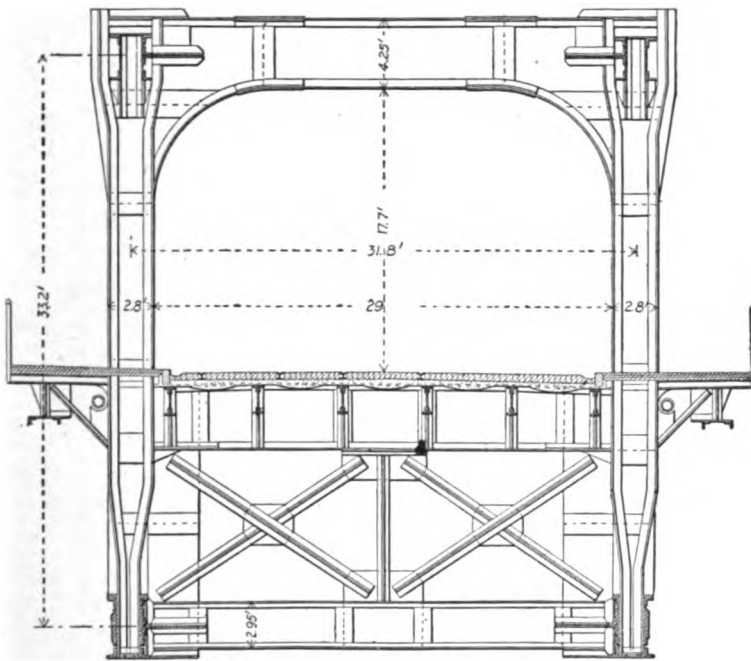

Portal and Sway; Bracing at Second Panel Point.

THE ENGINEERING RECORD

is in the design of the portal braces which are at the second panel points and are made with solid plate girders between the top and bottom chords and deep solid web knee braces at the ends of the top struts. The vertical posts at this panel point are of special design with I-shaped cross-section. The flange angles converge at the feet of the posts to be riveted to the insides of the lower chord webs, and diverge at the top to form forked connections engaging the outsides of the top chords, and the ends of the

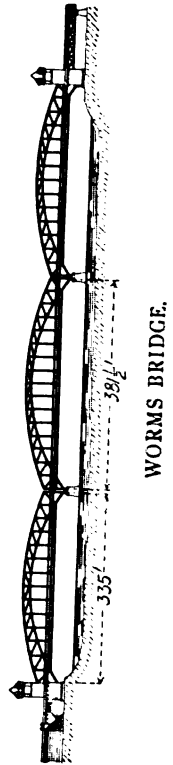
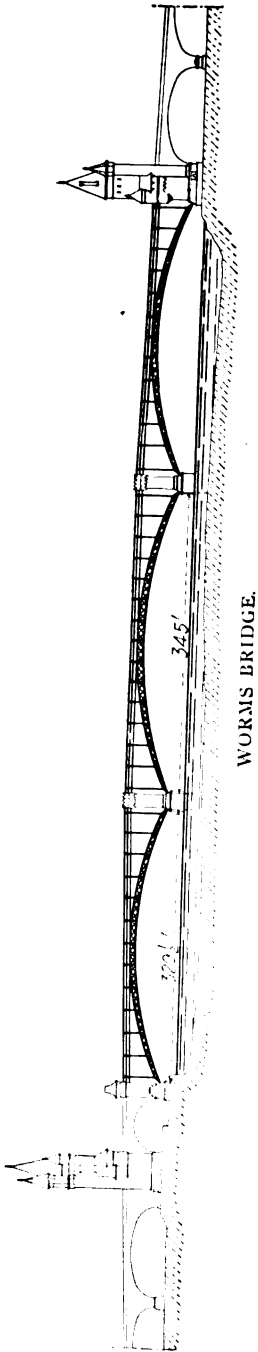

portal girders, besides which a center extension has vertical flange angles riveted across the insides of the top chord webs.

Among the long span two-hinge arch trusses abroad, for which details are not conveniently available, the following may be briefly mentioned. A bridge across the Danube, at Straubing, has one 298½-foot span with lune-shaped trusses carrying the

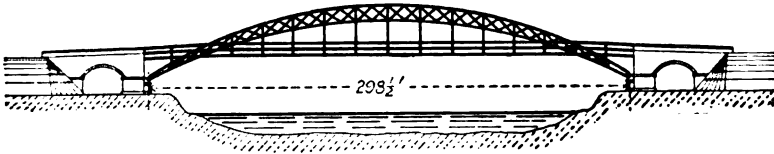

STRAUBING BRIDGE.

roadway about half way between the skewbacks and crown. A bridge across the Rhine, at Worms, has a 345-foot center span and two 329½-foot side spans, all having trusses with the top and bottom chords curved to flat arcs of eccentric circles and carrying the roadway on vertical spandrel bents above the level of the crown. This bridge has massive piers and is flanked by masonry arch approach spans and tall, imposing portal towers on both shores. A bridge over the Elbe, at Harburg, has four 328-foot channel spans with the trusses deepest at the ends and having

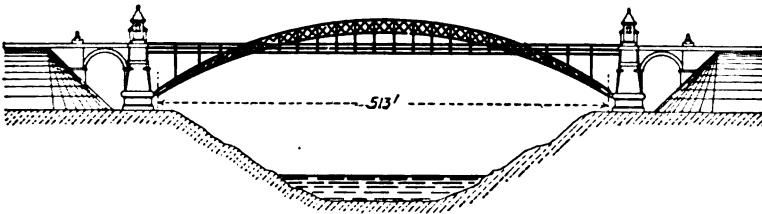

GRUENTHAL BRIDGE.

the top and bottom chords curved to arcs of eccentric circles and the roadway suspended at skewback level. Another bridge across the Rhine, at Worms, has a 381½-foot span and two 335-foot side spans similar to those of the Harburg bridge, but having the roadway level at about the middle of the vertical end posts and having large masonry portal towers on each bank. The Gruenthal bridge across the North Sea ship canal has a single high level span of 513 feet. Its shallow lune-shaped trusses are eccentric circular arcs and support a roadway midway be-

tween springing line and crown. The abutment piers are carried up far above the skewbacks and are flanked by short span masonry approach arches carrying the roadway to the top of the high banks. The Levensau bridge across the North Sea ship canal has a single 536-foot span and the chords of its shallow trusses are parallel circular arcs supporting double deck roadways at the levels of their crowns. The piers are very high and massive and are carried above roadway level as portal towers.

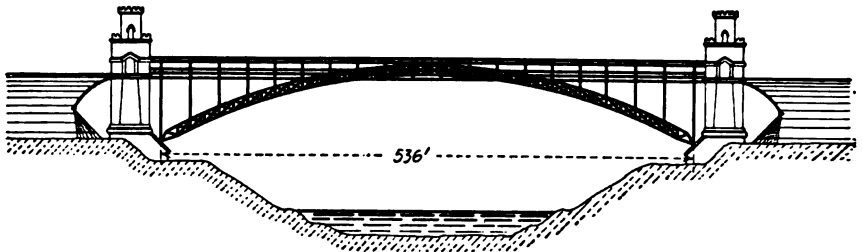

LEVENSAU BRIDGE.

The bridge over the Douro River, Portugal, has a 536-foot span which carries five spans of roadway girders at crown level on vertical spandrel bents and a single-span suspended footbridge at skewback level. The top and bottom chords of the trusses are arcs of eccentric circular curves and a line of longitudinal struts through the centers of the web members appears like a third chord through the neutral axis.

## CHAPTER XIII.

### **THE NIAGARA FALLS AND CLIFTON BRIDGE. SPAN 840 FEET.**

The Niagara Falls and Clifton highway bridge crosses the Niagara gorge about 1000 feet below the cataract and has a total length of 1240 feet, width over all of 46 feet, and height above the water of about 200 feet. It was described in paper 3243, presented by Chief Engineer L. L. Buck to the Institution of Civil Engineers, but no description of it has been published in the technical journals in the United States. This bridge is the third to occupy the site of a light suspension highway bridge of 1,268 feet span at the same level and having the center line coincident at one end, and diverging nearly 14 feet at the other end. It has a 210-foot and a 190-foot deck lattice girder approach spans and a main channel span with two two-hinge arch trusses of 840 feet span, center to center of skewback pins, and carries a single deck with two lines of trolley car tracks in the center, two carriage ways outside the car tracks and two cantilever sidewalks. The roadway has a grade of  $8\frac{1}{2}$  feet in the whole length of the bridge. The arch span is much stiffer than a suspension span and was built much more cheaply than the old span could have been widened and strengthened to an equal capacity. Trusses with parallel chords instead of trusses with spandrel bracing were adopted because of the great span, the inclined floor, the desire to obstruct the view of Niagara Falls as little as possible and to keep the erection weight as low as possible. The arch is notable for having the longest span of its kind ever built; for its height, beauty and conspicuous position; for its daring and rapid erection, and because it illustrates advanced practice in design and construction.

The bridge is designed for the following loadings: For arch trusses, on carriage-ways and sidewalks, 50 pounds per square foot; on railroad tracks, 1 motor, 4 trailers to each track; where it gives greater stresses, or a uniformly distributed load over the entire span, equivalent to trains of 1 motor and 1 trailer "Ely train," 200 feet apart in the clear on one track where it gives greater stresses. For floor system and posts of bents, on car-



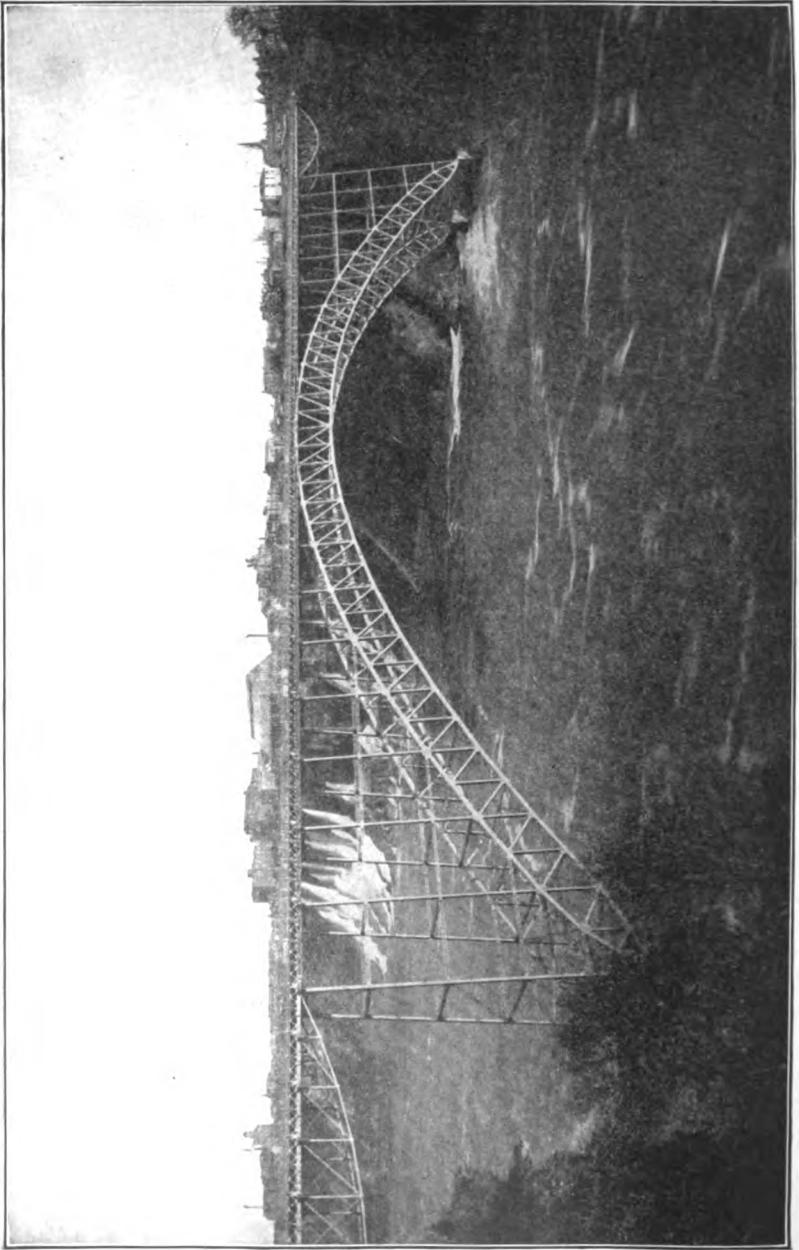

THE NIAGARA FALLS AND CLIFTON 840-FOOT SPAN HIGHWAY BRIDGE.

riage-ways and sidewalks, 100 pounds per square foot; on rail-road tracks, 1 motor and 1 trailer "Ely train" to each track. Wind pressure is taken at 200 pounds per running foot, 70 pounds of which goes to the ends through the floor laterals, and the remainder down the bents and thence along the ribs to the skew-backs. Wind pressure on posts of bents and on rib members is taken at 30 pounds per square foot on vertical projections of these members, multiplied by 1.67. Added to the wind pressure at top of bents is the horizontal thrust, due to live load being on one side of bridge only. Stresses in lateral struts are obtained by an initial stress of 10,000 pounds per square inch being put on all lateral ties connected. Temperature stresses are computed from horizontal thrust of 270 pounds per square inch at skew-back. Where wind stresses in rib of arch exceed 20 per cent. of live plus dead plus temperature stresses, allowance has been made for this excess, using dead load units. Eight-tenths of the reverse strain is treated as live load, both in the proportioning of section and the number of rivets required. Twenty per cent. added to number of rivets required by table in case of field rivets. The ordinary train load consists of alternate motor cars and trailers, together occupying a length of 54 feet. The motor has two axles 7 feet apart with 14,600 pounds on each, and 20 feet 8 inches away is the trailer with two axles 7 feet apart loaded with 9250 pounds each. The Ely train has one motor and one trailer spaced 13 feet 1½ inches apart between axles, the motor having four axles spaced 6 feet 3 inches, 10 feet 3 inches and 6 feet 3 inches apart, each loaded with 12,500 pounds, and the trailer, four axles spaced 4 feet, 16 feet and 4 feet apart, each loaded with 9250 pounds.

The unit stresses were proportioned as follows: Rivet bearing, 15,000 pounds per square inch, shearing, 7500; pins, bending, 20,000; bearing, 12,000; iron rods and bars in tension, 10,000.

$$\text{Chords, live load} \dots \dots \dots = \frac{12,000}{L^2} \div 1 + \frac{30,000}{R^2}$$

Dead load and temperature = 20,000.

$$\text{Posts and braces, live load} \dots \dots \dots = \frac{10,000}{L^2} \div 1 + \frac{30,000}{R^2}$$

Dead load and temperature = live load × 2

$$\text{Posts, live load} \dots \dots \dots = \frac{12,000}{L^2} \div 1 + \frac{30,000}{R^2}$$

$$\text{Lateral struts} \dots \dots \dots = \frac{12,000}{1 + \frac{L^2}{30,000 R^2}}$$

Lateral ties 15,000.

$$\text{Top chord floor beams and stringers live load} \dots = \frac{10,000}{1 + \frac{L^2}{30,000 R^2}}$$

Wind and dead load = live load  $\times$  2.

Bottom chord floorbeams and stringers.

Live load = 10,000 net.

Wind and dead load = 20,000 net.

$L$  is the length of the member and  $R$  is the least radius of gyration.

The stresses in the arch trusses were computed by the three formulas from part III. of "Trusses and Arches" by Professor Charles E. Greene, University of Michigan.

$$H = \frac{1 - n^2}{2} \times \frac{5(5 - n_2)}{3^2} \times \frac{c W}{K}.$$

$$M = H(\nu - z) \text{ and } V = P_1 - Y_1 = \frac{c \pm b W}{2c} - \frac{2KH}{c}$$

$H$  is the horizontal thrust at abutment,  $M$  the bending moment and  $V$  the abutment shear.

It was assumed that two-thirds of the wind pressure would go directly through the spandrel bents to the arch trusses, and that the horizontal truss, 46 feet deep formed by the fascia girders and the lateral diagonals and floorbeams would act as cantilevers 420 feet long from abutments to mid-span and transfer the remaining one-third to the tops of the end spandrel bents. The bridge is built of basic open-hearth steel with a tensile strength of 62,000 to 68,000 and an elastic limit of 33,000 pounds per square inch and an elongation of 20 per cent. in 8 inches.

The maximum pressure on the top of the masonry of both abutments on each side of the river is 4,729,000 pounds in a direction making an angle of  $44\frac{1}{2}$  degrees with the horizontal. The maximum pressure on the copings is 220 pounds per square inch, and on the concrete, 101 pounds per square inch. The maximum vertical pressure on the material underlying the foundation is about 35 pounds per square inch. The maximum horizontal pressure would be about 150 pounds per square inch on the vertical surface of the solid rock if no allowance were made for bottom frictional resistance to thrust. With a coefficient of friction of 0.55 for rock and 0.75 for the boulder and gravel bot-

tom the horizontal bottom friction alone would be sufficient to hold the abutments in place under maximum load. The abut-

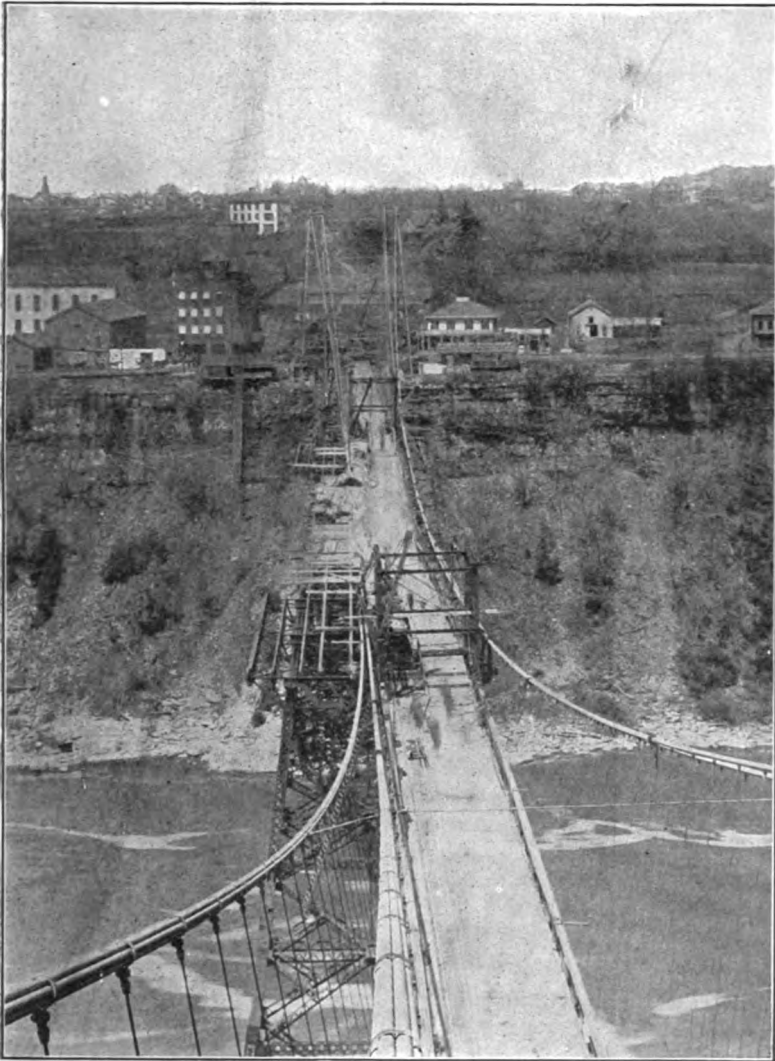

VIEW FROM TOP OF OLD TOWER OF ERECTION OF ARCH TRUSSES UNDER SUSPENSION BRIDGE IN SERVICE.

ment piers are designed for a future increase of 25 per cent. in the loading of the bridge.

The top and bottom chord panel points were numbered from

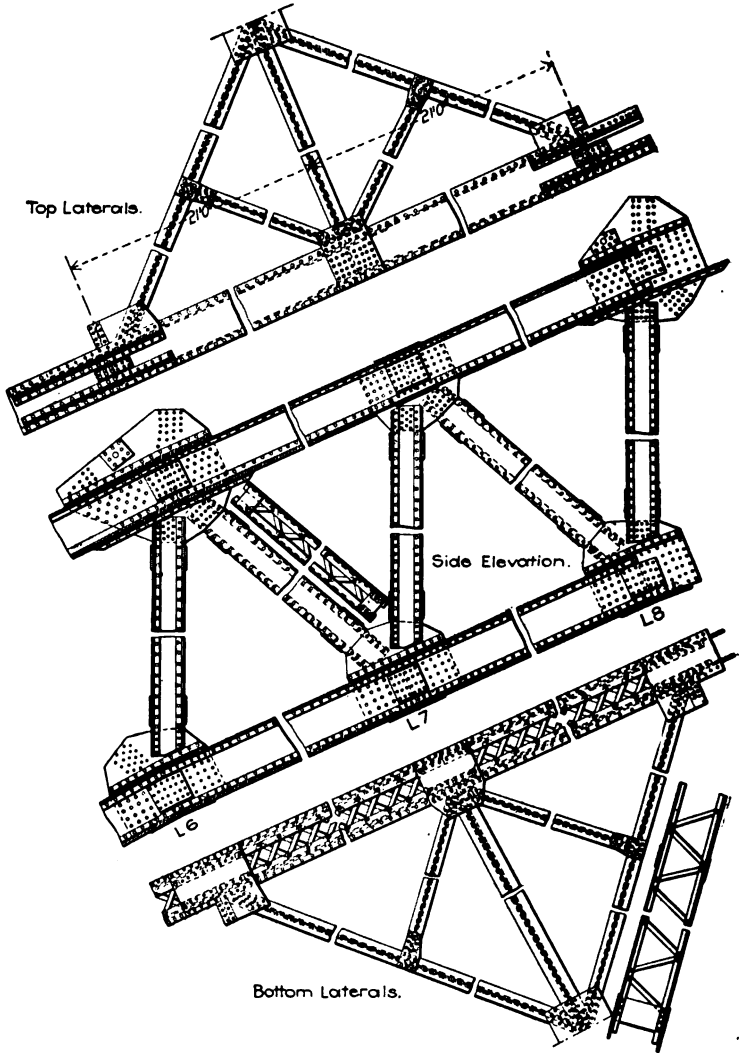

Intermediate Panels of Main Truss and Laterals.

THE ENGINEERING RECORD.

the ends of the trusses to the center, calling the skewback pin  $O$ , the adjacent points  $U_1$  and  $L_1$  and the crown points  $U_{20}$  and  $L_{20}$ . The maximum stresses, cross-sections and areas are as follows,  $U_7$   $U_8$ , 2,798,000 pounds, eight  $3\frac{1}{2} \times 3\frac{1}{2} \times \frac{5}{8}$ -inch flange angles, four  $24 \times 15/16$ -inch web plates, two  $25 \times \frac{7}{8}$ -inch cover plates, four  $8 \times 13/16$ -inch reinforcement plates, total, 186 square inches;  $L_{11}$   $L_{12}$ , 2,462,000 pounds, eight  $3\frac{1}{2} \times 3\frac{1}{2} \times \frac{5}{8}$  flange angles, four  $24 \times \frac{7}{8}$ -inch web plates, two  $25 \times 9/16$ -inch cover plates, four  $8 \times 11/16$ -inch reinforcement plates, total 166 square inches;  $U_{19}$   $L_{19}$ ,

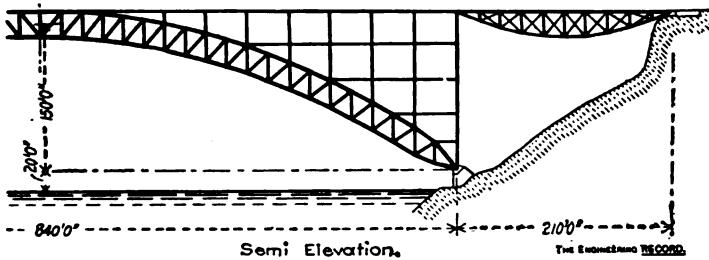

197,000 pounds, eight  $4 \times 3 \times \frac{5}{8}$ -inch flange angles, four  $16 \times \frac{5}{8}$ -inch web plates, total 44 square inches; lateral diagonal,  $U_2$   $U_4$ , two pairs of  $4 \times 3 \times 5$ -16-inch flange angles, latticed; transverse struts, two pairs of  $5 \times 3 \times 5$ -16-inch angles, latticed; lateral diagonal;  $L_2$   $L_4$ , 54,000 pounds, two pairs  $5 \times 3 \times 5$ -16-inch flange angles, latticed; transverse struts,  $L_3$   $L_3$ , two pairs  $5 \times 3 \times 5$ -16-inch angles, latticed; all sub-diagonal laterals, two pairs  $3 \times 3$  or  $3 \times 2\frac{1}{2}$ -inch angles, latticed.

The two arch trusses of the main span are divided by vertical posts into forty 21-foot panels, braced by single diagonal struts, and are battered so as to be 69 feet apart at skewbacks and 39 feet at the centers of the top chords. The top and bottom chords have riveted splices at all panel points and the straight panel

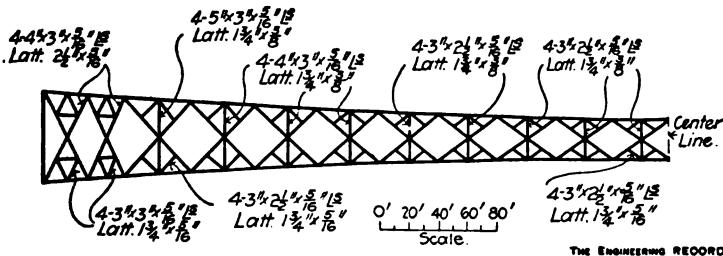

Lateral System of Top and Bottom Chords.

lengths are chords of parabolic curves 26 feet apart on centers except in the two panels nearest the skewbacks where they converge to intersect on the centers of the hinges. The lower chord has a rise of 137 feet and the top chord has a rise of 163 feet. The top and bottom chords are braced by I-shaped transverse struts and diagonals as indicated in the diagram. The transverse struts are stiffened by vertical connecting struts at the center, and all

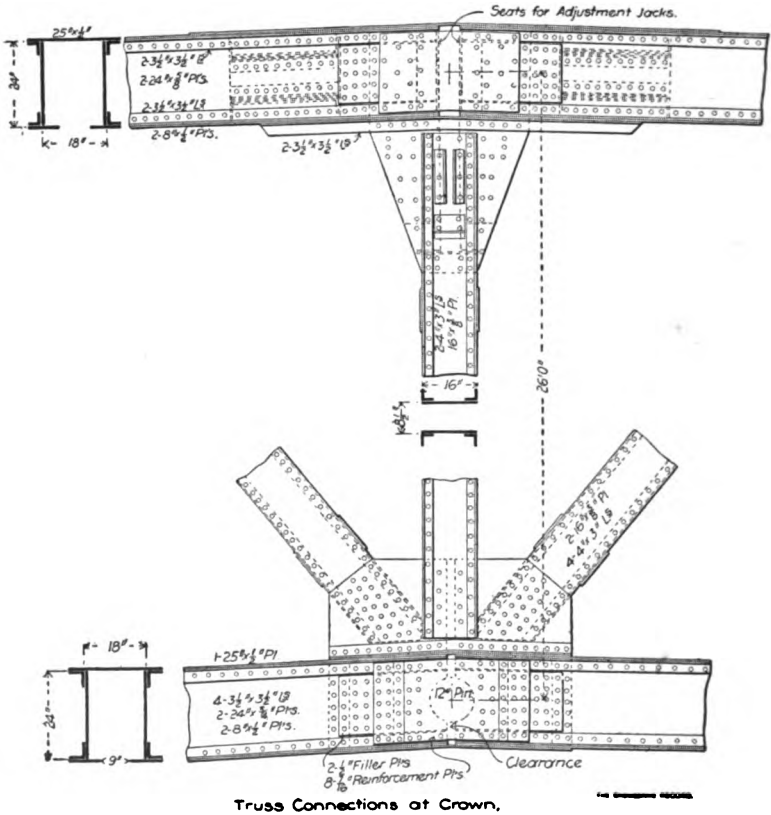

transverse panels are X-braced by adjustable rods pin-connected at both ends and at their intersections. The lateral struts are field-riveted to jaw plates on both flanges of both chords. At alternate top chord panel points, the web connection plates for the vertical posts and diagonals are extended above the top chords to receive the spandrel posts supporting the roadway platform. These posts are made of pairs of channels latticed and the longer ones have horizontal struts, but no diagonal braces in longi-

tudinal planes. All have sway bracing of horizontal struts and pin-connected diagonal rods in vertical transverse planes. The rods are connected with separate pins to pairs of connection plates at intersections. The longitudinal struts have flange connections

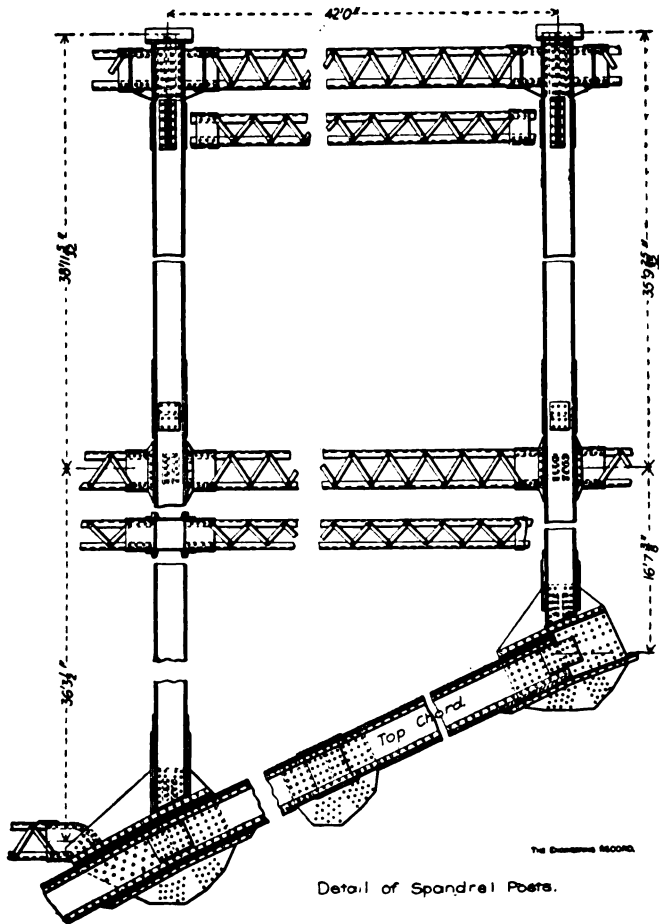

to the spandrel posts and transverse struts are connected to jaw plates riveted to the post flanges.

The floorbeams are lattice girders 30 feet long and 6 feet deep with drop ends and horizontal base plates seated on the spandrel post caps. The top chords of the floorbeams are extended nearly 8 feet beyond the post centers to make cantilever sidewalk brackets, which are kneebraced to connection plates on



the spandrel posts, which also receive struts to the ends of the bottom chords of the main floorbeams. The floor platform has lateral X-bracing in every panel and is covered with longitudinal planks or transverse wooden joists. Each street car track has two lines of lattice girder stringers 53 inches deep and 6 feet apart with drop ends, two lines of latticed fascia girders  $3\frac{1}{2}$  feet deep web-connected midway between the chords to the ends of the sidewalk cantilevers, and four lines of roadway and sidewalk stringers all seated across the top flanges of the floorbeams.

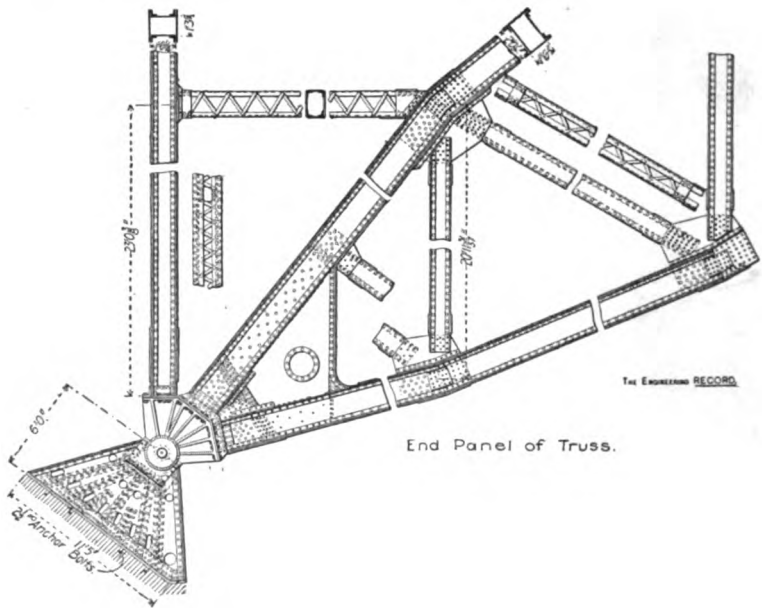

All the truss members have rectangular cross-sections with nearly equal width and height, as indicated by the materials of the maximum pieces. The chords are trough-shaped and the diagonals have their angle flanges turned inwards. All connections are very simple, are riveted solid and correspond to those shown in the typical details. The ends of the top and bottom chords are united by solid web plates about 10 feet deep, which are common to both members and extend from the skewbacks to the middles of the first panels, making closed rectangular cross-sections and solid ends for the trusses. These are triangular in vertical elevation and have notched ends with flange angles seated on cast-steel webbed bearings which have half holes engaging the

12-inch skewback pins nearly 6 feet long. These pins are seated in steel castings with rectangular trough-shaped cross-sections which are engaged by recesses 2 feet wide in the tops of riveted

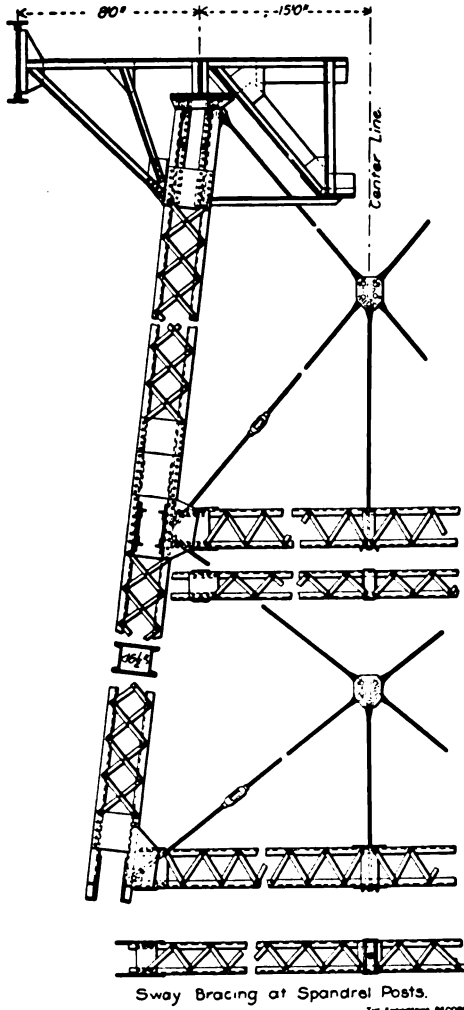

steel pedestals with three main longitudinal webs which are connected by nine transverse diaphragms and distribute the load on a masonry surface about  $11\frac{1}{2}$  feet long and 6 feet wide which is normal to the pressure and inclined about 45 degrees from the vertical. The steel castings which are bolted to the ends of the

trusses are oblique to correspond with the batter of 6 degrees and 47 minutes of the trusses, and the axes of the pins are normal to the vertical plane through the bridge axis. The pins have end

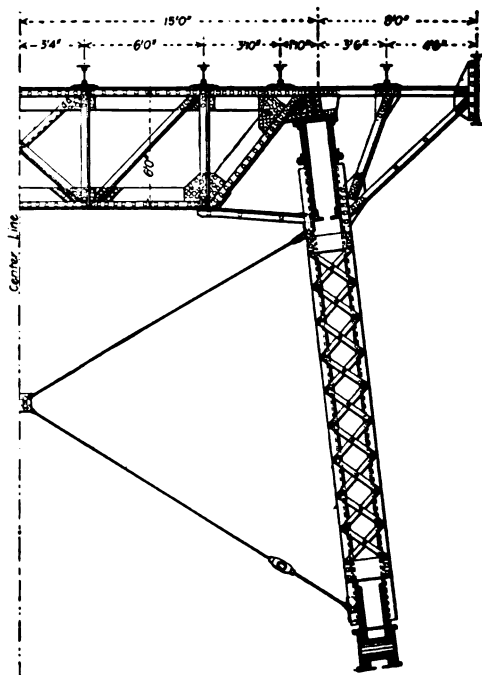
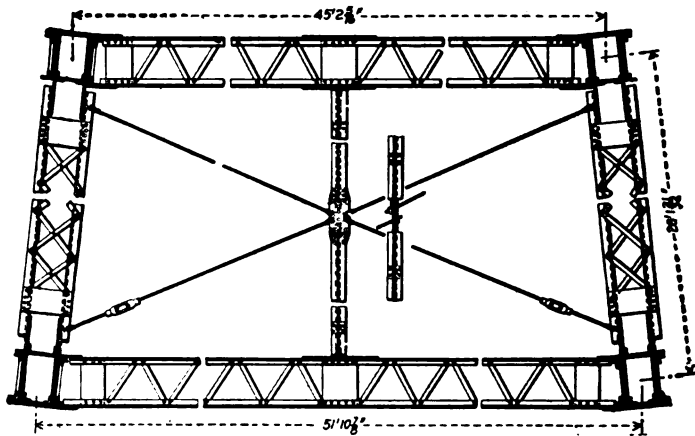

and center collars to lock them to the upper and lower castings, and the ends are capped with discs secured by bolts through the axis of the pin.

The abutments are built of first-class limestone masonry with

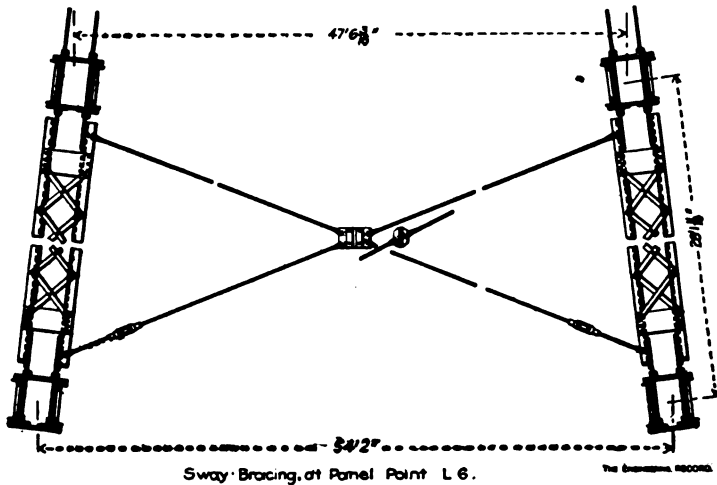

courses 2 feet thick stepped off, on the New York side, on the sloping surface of the solid sandstone rock. On the Canada side, the footings are 2:5:9 American Giant Portland cement concrete laid in pits excavated in a stratum of cemented gravel and boulders.

The arch trusses rise to a total height of nearly 240 feet above the water. Underneath the bridge the river has a depth of about 180 feet and a current of about 5 miles an hour, so that the use of falsework supported on the bottom was out of the question. The roadway had to be built at about the same level as that of the existing suspension bridge, on which traffic was required to be maintained. The axis of the new bridge was coincident with that of the old bridge at one end, and only diverged  $13\frac{1}{2}$  feet from it at the other end. Much of the erection was carried on at a great height, in a situation exposed to violent winds sweeping up the gorge, and where the air was very often filled with a drenching spray from the cataract. The trusses were designed without any center hinge and the lengths of the center panel members were calculated for final connections at mean temperature. Part of the erection work was accomplished in winter weather when there was severe cold and much

ice to contend with, besides the effects of wide changes of temperature on the lengths of the steel members. The batter of the trusses, the grade of the roadway and the joints in the parabolic curves of the chords which were differently beveled at all splices made very accurate shop work necessary and gave unusual opportunity for error, and the riveting of all the field joints instead

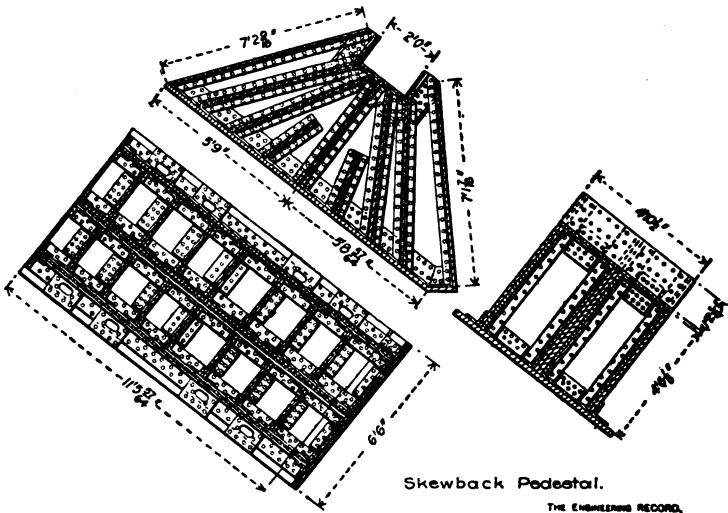

of connecting them with pins added to the difficulty and risk of the erection. It was therefore decided to erect the semi-trusses as cantilevers with back stays from alternate panel points of the top chords to shore anchorages.

Trestle falsework was built on the steep slopes between the skewback piers and the tops of the banks on both sides of the river, and on it the top chords of the approach spans were assembled in final position, and their splices fully made so that they developed sufficient tensile strength for anchorage purposes. The shore ends were connected to the anchorages and the skewback pedestals, castings and hinge pins were set and the end vertical bents were erected on them and permanently pin-connected at the tops to the river ends of the approach span top chords. The 42-foot end panels of the trusses were erected from the skewback pins and supported intermediately by the falsework trestle bents, under the bottom chords and back stays, and from their end top chord panel points were connected to the tops of the river ends of the anchorage chains. The truss members were brought out

singly by trucks running on the floor of the old suspension bridge and were unloaded, lowered and assembled by booms on the sides of a light steel tower, traveling on the top chords of the stiffening trusses of the suspension bridge and clearing its traffic. The sec-

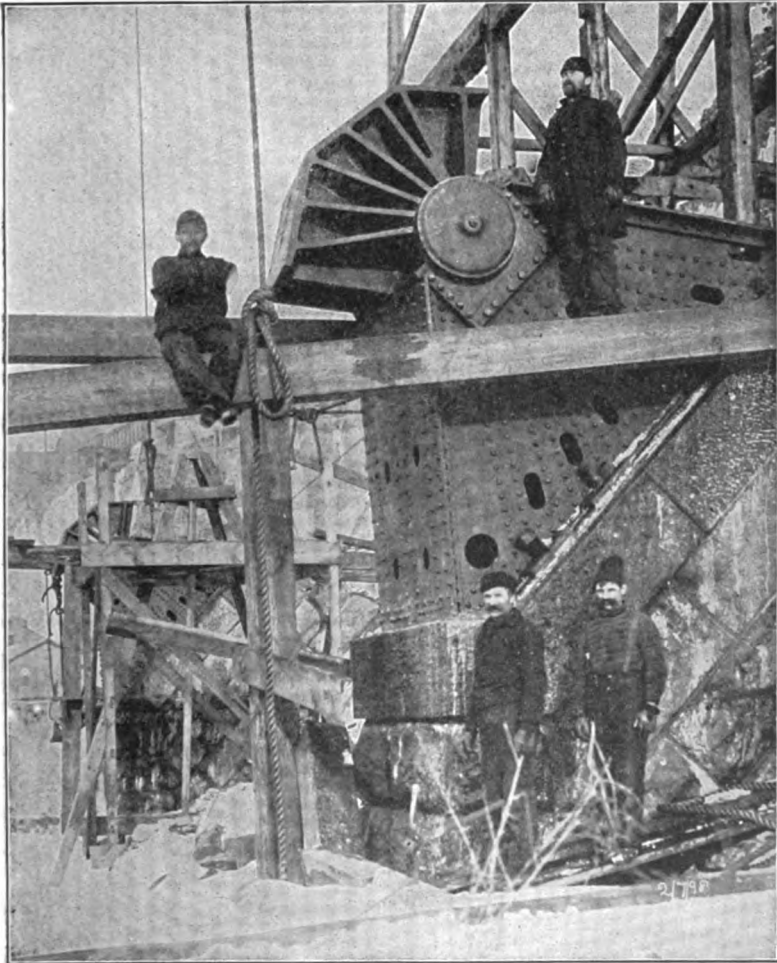

SKEWBACK HINGE.

ond spandrel bent was erected to the top story and was braced to the first one to form a tower and the traveler advanced, erecting successive panels of the trusses, which were supported by back stays from the extremities of their top chords with separate pin connections to wide vertical plates engaging pins through the

ends of the anchorage chains. Erection was carried on simultaneously from both ends of the bridge by duplicate travelers, which met in the center of the span. The adjacent ends of the semi-trusses were manipulated by adjustments in the back stays and by toggles in the anchor chains, by which they were raised or lowered to give contact on the center pins of the lower chords,

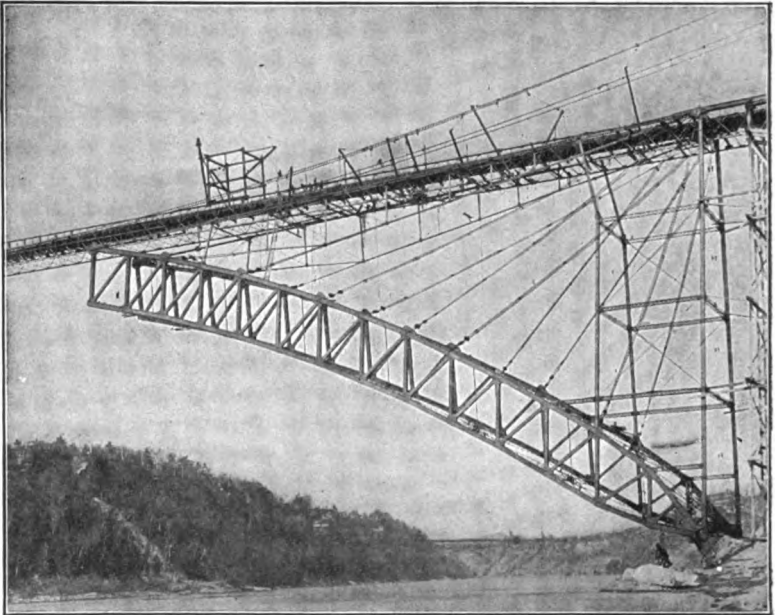

GUYED CANTILEVER ERECTION OF SEMI-SPAN.

thus temporarily forming three-hinge arches. Hydraulic jacks were then inserted between the ends of the top chords and forced them apart until they developed the required stresses in the top chords and transferred the compression in them to permanent cast-iron key blocks inserted in place of the jacks.

From the shore ends of the top chords of the approach spans, the anchor chains were continued in the same lines by sets of horizontal eye-bars reaching to the centers of the anchor wells and connected there to vertical eyebars about 23 feet long, which had bottom pins engaging saddles across the under sides of sets of five 15-inch I-beams about 6 feet long. These formed a reaction platform solidly bedded in concrete, filling the chamber cut out of solid rock at the foot of a 3 x 6-foot vertical shaft 16 feet deep. The pin connecting the horizontal and vertical bars,

at one end of the bridge, was supported on an inclined strut. The pin at the other end was much nearer the surface of the ground and was supported directly by the pedestal and grillage bearing,

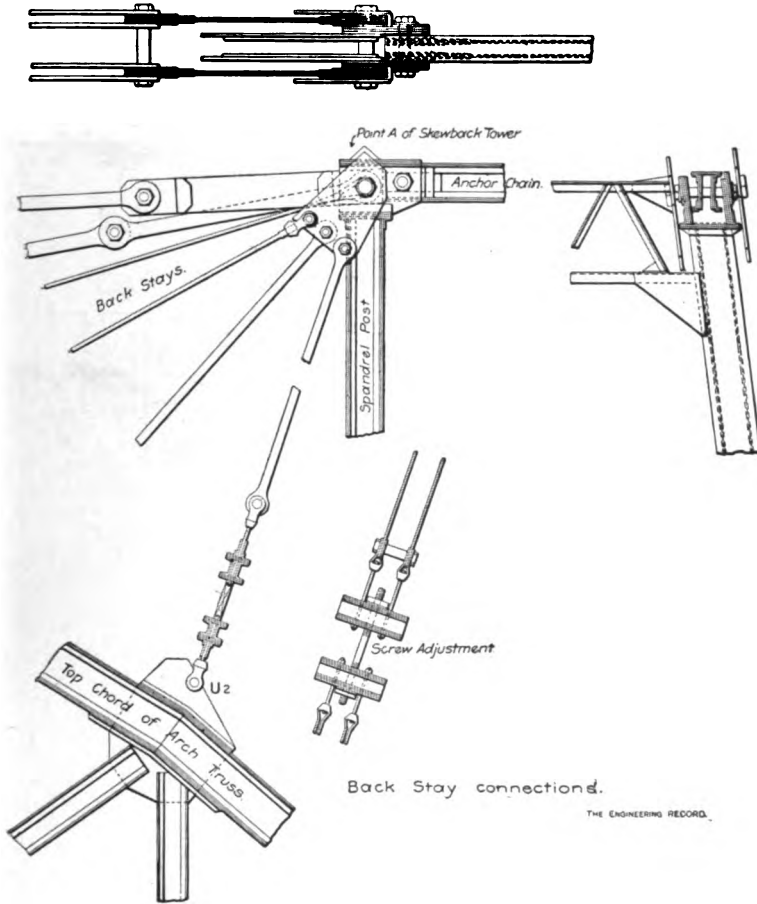

but was also tied back by horizontal U-bars with screw ends engaging transverse horizontal beams bearing across vertical timbers set in the rock.

The toggle joint adjustments were inserted in the anchor chains close to the vertical bars and were the same as were used for the similar erection of the 550-foot arch trusses of the Niagara railroad arch bridge. Each consisted of an oblique parallelogram in a vertical plane, the sides of the parallelogram being made with four eyebars connected on the vertical diagonal to riveted



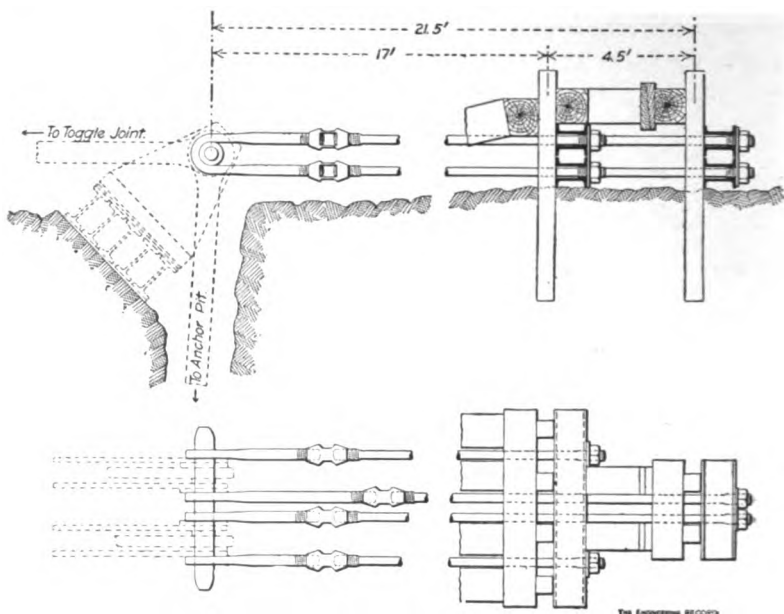

Horizontal Anchorage for Erection Adjustment.

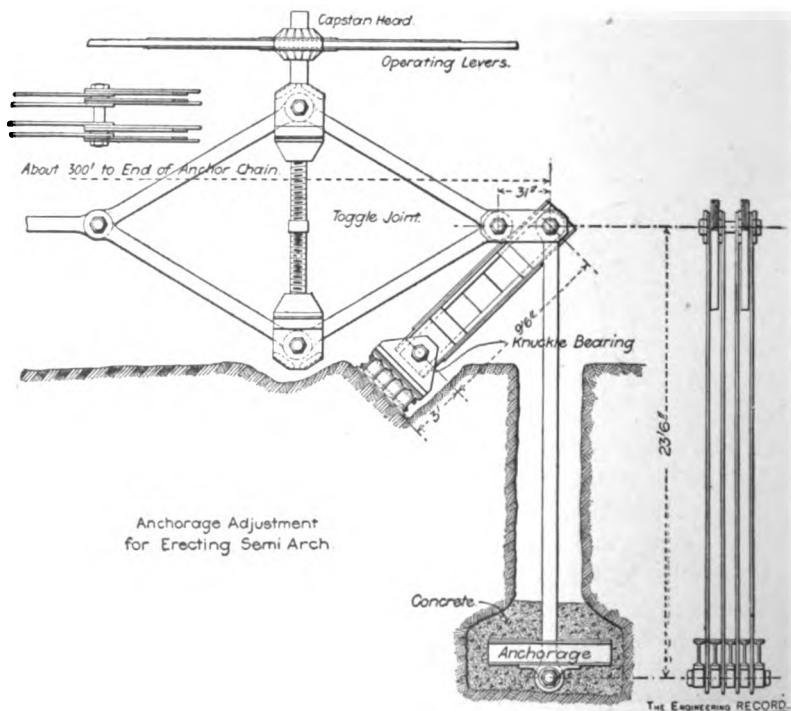

Anchorage Adjustment for Erecting Semi Arch

boxes containing right and left-hand cast-iron nuts, through which a vertical screw passed. The top of the screw had a capstan head, operated by eight horizontal levers to contract or elongate the vertical diagonal of the parallelogram, thus lengthening or shortening the anchor chain of which it formed a link and so adjusting the positions of the semi-trusses and raising or lowering their extremities. They were erected so as to require lowering only, which was easily accomplished by twenty men at each toggle.

The third and fourth back stays for each semi-truss were made with loop ended rods, the rest were eyebars, all except the upper one being provided with long screw adjustments near their connections to the top chords, as shown in the detail. The nuts on the ends of the connecting screw and on the clevis rods afforded three adjustments if necessary. The upper back stay differed from the others in that it was not adjustable and that it was so long as to require bracing to prevent excessive sagging. This was secured by verticals and diagonals connected at panel points to the next back stay so as to make with it a truss. The adjustable back stays were screwed up so that the upper one could be connected and were then removed, leaving the ends of the trusses supported by the two upper back stays in such a position that there was just sufficient clearance for the insertion of the last two sections of bottom chord. The adjustment toggles were then slacked off until the ends of the semi-trusses took bearing on the lower chord 12-inch center pin.

In each truss two special horizontal 250-ton hydraulic jacks were set against vertical transverse diaphragms riveted in the ends of the middle sections of the top chord with bearings against adjustable filler plates. The jacks were operated by 30-ton vertical jacks connected to them as shown in the detail, and the original space of 3 inches between the ends of the top chords, when the trusses acted as three-hinge arches, was increased to 6 inches, developing exactly the calculated compression of 375,000 pounds in each top chords, as observed by pressure gauges on the main jacks. The plungers of the 30-ton jacks were so short that they had to make several strokes before the required movement of the 250-ton jacks was secured. Temporary shims were then packed between the ends of the chords to secure them for several days until the permanent cast-iron spacing blocks could be planed to length and inserted and when the jacks were pumped up again for this purpose the pressure again registered exactly the required

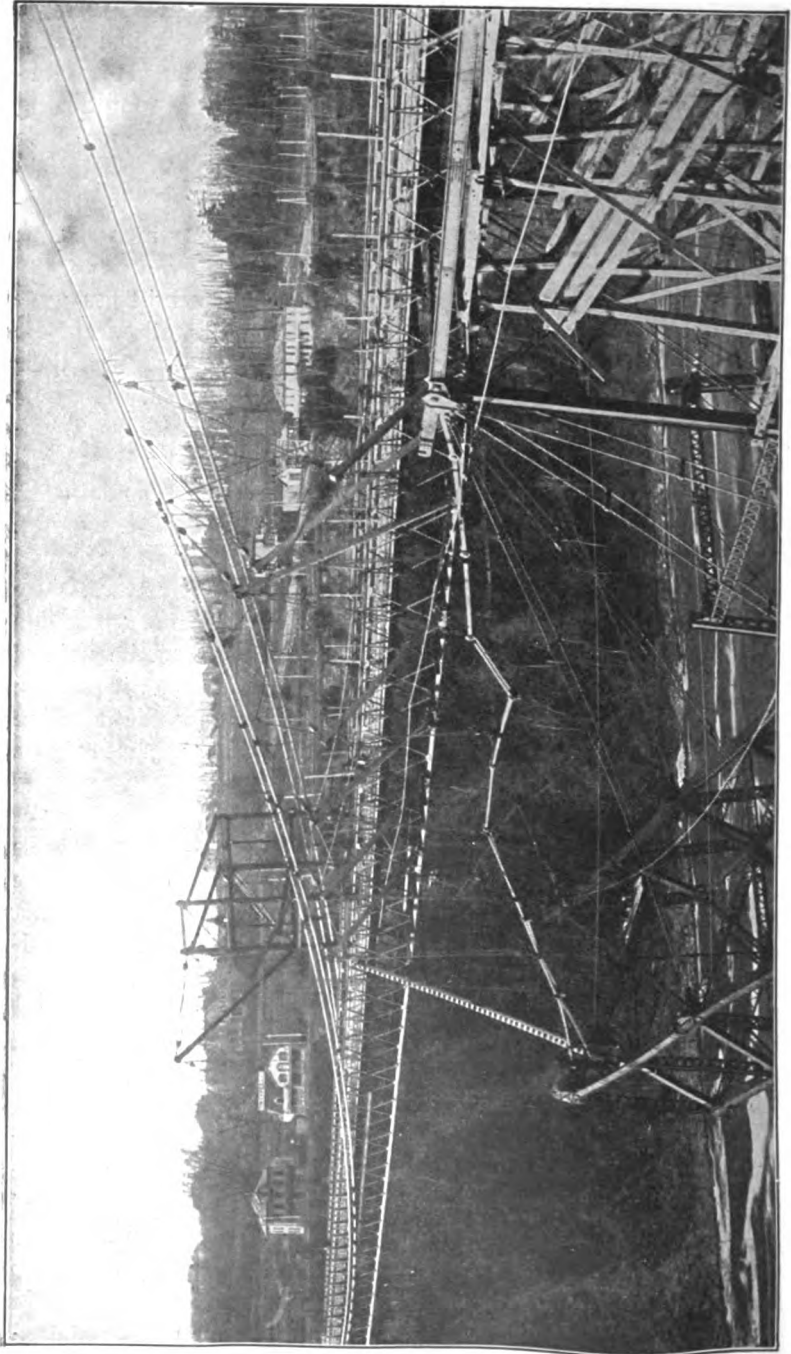

KEY-BAR GUYS FOR CANTILEVER ERECTION OF SEMI-ARCH TOWERS.

375,000 pounds. By this means the theoretical distribution of stress was secured and the accuracy of the calculations and of shop and field work was satisfactorily demonstrated.

The erecting travelers were two-bent unsymmetrical towers with four vertical posts braced together with horizontal, longitudinal and transverse struts, and pin-connected diagonals in all faces. Each vertical post served as a mast for a 5-ton steel boom, those on one side being about 13 feet long and those on the opposite side being about 29 feet long to reach out over the diverging arch truss. All compression members were made with pairs of channels latticed, and two seats at different levels were provided for the booms, the rear ones being raised during the latter part of the erection. The heaviest pieces handled by these trav-

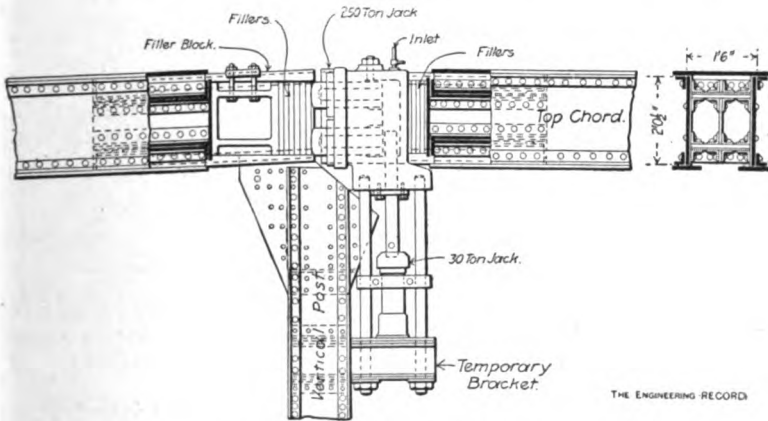

Top Rib Center Adjustment.

THE ENGINEERING RECORDS

elers weighed 5 tons and special riveted clamps were bolted to the top chord pieces and received the hoisting tackles in such a manner that the chords hung suspended in the required camber planes. Pairs of wooden jaw pieces were clamp-bolted to the stiffening trusses of the old suspension bridge and made seats for derrick booms used for handling the spandrel bents and other light members after the arch trusses were assembled. The upper blocks of their topping lift tackles were attached to the main cables of the suspension bridge.

The old floor and all of the stiffening trusses except the top chords were removed in the center of the bridge to clear the centers of the arch trusses and the travelers were carried across on a temporary floor, the weakened old structure developing re-

markable rigidity under the 25,000-pound loads of the travelers. The travelers met at the center of the span on the completion of the arch trusses and then worked back to the ends of the span, erecting the floor system, which was assembled under raised movable bridges in single panels 42 feet long. The old stiffening trusses were taken out in corresponding 42-foot lengths as the new floor was completed, and after the floor planks were laid complete on one side of the bridge the old main cables were cut in two at the middle and removed. The travelers were operated by six and eight-spool hoisting engines located on shore, and all field-rivets were hand driven. The main span was practically erected in three months' working time by an average force of 100 men, three of whom met with fatal accidents. The longest inter-

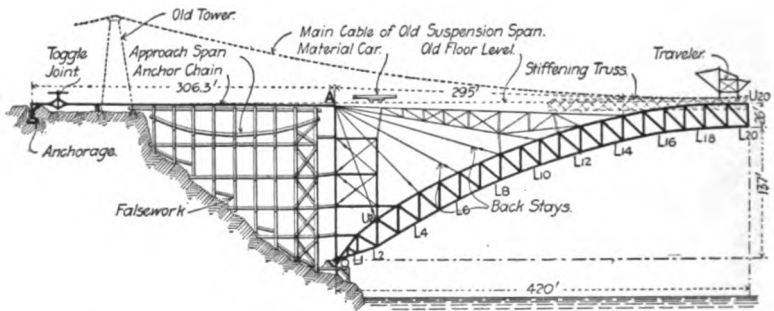

Anchorage and Back Stays for Erection of Semi Arch.

ruption to traffic was three days and the aggregate interruption was seven days. The total masonry in all four abutment piers is 1417 yards of concrete and 220 yards of stone masonry. The total weight of the main span was 3,651,081 pounds, classified as follows: Trusses, 1,673,356 pounds; arch laterals, 383,552; spandrel bents and laterals, 450,557; longitudinal bracing, 150,705; skewbacks and shoes, 226,634; floor system, 766,287 pounds. The foundations were commenced in September, 1895, and were finished in June, 1896; the erection of the superstructure was not begun until March 1, 1898; it was completed sufficiently for trolley cars to run across the bridge June 30, and was entirely finished August 10, 1898.

## PART IV.

### PLATE GIRDER ARCHES.

Plate girder arches are generally two-hinge riveted steel structures, but may be three-hinge or hingeless, or maybe made of cast-steel. They can be selected where natural reactions are to be utilized to provide for the horizontal thrust and the spans are too short for economical arch trusses, and can be designed to emphasize the arch effect of longer spans. Usually the details of riveted steel ribs conform to the standards for horizontal plate girder spans of corresponding length, but in some cases they are made with double webs. Small spans of minimum weights have been made with ribs having solid plate girder-like webs at the ends, and latticed webs at the crown where the depth was greater. The advantageous length of span is limited by the weight and dimensions of the rib-sections, and the difficulties of making satisfactory field splices, and the maximum so far constructed is only a little over 500 feet. Long spans are likely to lack rigidity, but they may be treated to secure special landscape effects and to require a minimum headway as in the Alexander III. cast-steel plate girder span in Paris.

## CHAPTER XIV.

**SEVERN, WEARMOUTH, LOUVRE, AUSTERLITZ, SOUTHWARK, HUNSLET, BUFFALO PARK, VICTORIA GORGE, BERLIN, BELLE ISLE, RIVERSIDE DRIVE AND CORNHOUSE BRIDGES. SPANS 40 TO 113 FEET.**

The first iron bridge ever built was an arch of 100 feet span across the Severn River, England. It was described in "The Engineering Record" of March 5, 1892. It has five ribs resting on horizontal skewbacks. Each rib is composed of three concentric segmental cast-iron arcs, the inner one with a 45-foot radius being nearly full-centered. The outer ribs extend only from the skewbacks to the haunches, and are connected together by radial struts, but not with diagonal braces so as to form trussing. The

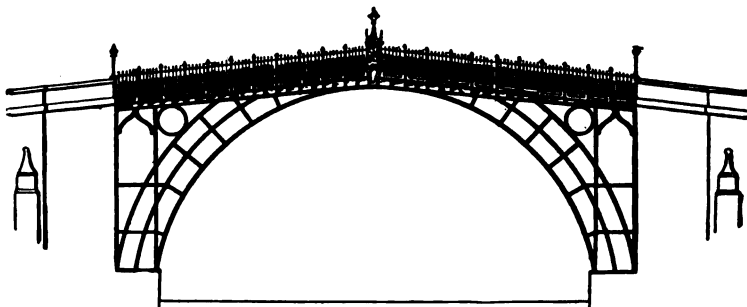

SEVERN RIVER 100-FOOT CAST-IRON SPAN.

lower member of each rib is  $8\frac{1}{4}$  inches deep and  $5\frac{1}{4}$  inches thick, and was cast in two pieces in open sand moulds. The upper rings of the rib are each  $5\frac{3}{4}$  inches square. The bridge has vertical spandrel posts and curved members, which are equivalent to spandrel arches and support the roadway platform. Its weight is 378 tons; it was opened for traffic in 1779, and was still serviceable and in use at the date of the description above mentioned.

The Wearmouth Bridge, in Durham, England, was completed in 1796, and consists of a single 236-foot span. It has six cast-iron segmental arch ribs with a rise of 34 feet. Each rib consists of cast-iron panels like voussoirs with grooves cast on both sides

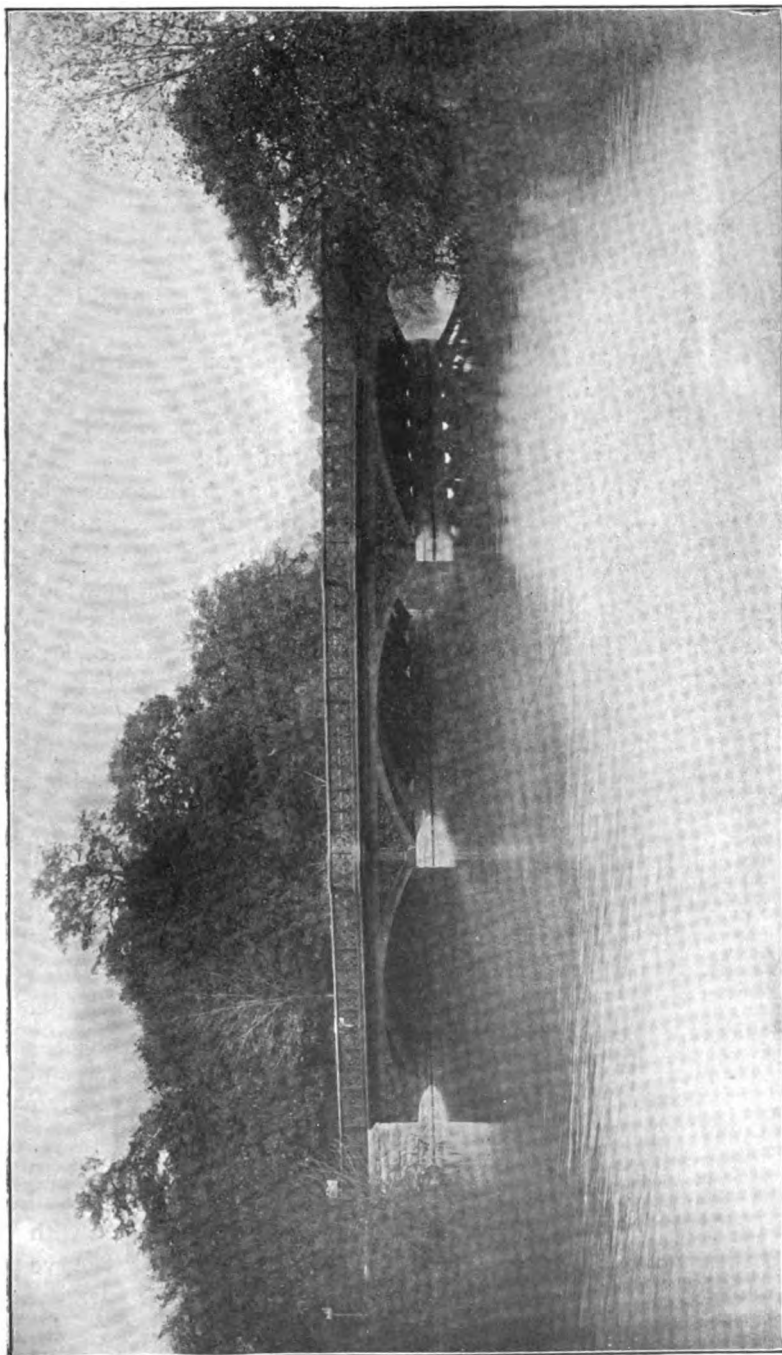

**BUFFALO PARK BRIDGE, 40-FOOT SPAN.**



in which wrought-iron diagonal bars are bolted to truss them. The Pont du Louvre, at Paris, France, was built in 1803, and has nine cast-iron arches of 57-foot span and 10 feet 8 inches rise. The Pont d'Austerlitz was finished three years later and has three cast-iron arches of the same rise and 106-foot span. The Southwark Bridge over the Thames, at London, England, was completed in 1819. It has a 42-foot roadway carried on three cast-iron arch spans. The center arch is 240 feet long with a rise of 24 feet; the two side arches are 210 feet long with a rise of 21 feet. Each arch has eight ribs, each of which is composed of thirteen segments 6 feet deep. The Hunslet Bridge over the Aire River, at Leeds, England, has a 152-foot cast-iron span with two ribs. The ribs have ball and socket skewback joints, and are each composed of six voussoirs, doweled together. The roadway beams are suspended from the ribs by wrought-iron rods.

Very cheap and simple highway bridges of 30 feet spans with wooden arch ribs were built for the Pan-American Exposition in Buffalo, and described in "The Engineering Record" of October 26, 1901. Each span had nine ribs about  $6\frac{1}{2}$  feet apart on centers and 35 feet long between centers of supports. Each rib had a 12 x 12 inch solid rectangular cross section made of four 12 x 4 inch hemlock planks bolted together flatways, curved to the arch of a circle 50 feet in diameter and keyed with cylindrical oak pins 2 inches in diameter. The ends of the ribs were seated in cast-iron shoes notched into caps bolted to the abutment piles. The intrados had a rise of 7 feet and was scarfed out at the skewbacks to resemble an elliptical curve, and the ribs were ceiled with transverse boards to form a smooth soffit. The roadway stringers were slightly inclined from the horizontal and were flush with the extrados of the ribs at the crown, where they were bevelled to fit it. Over the haunches they were supported by 2 x 12-inch vertical studs 16 inches apart, which were sheathed by diagonal planks in vertical longitudinal planes. The floor of 2-inch planks laid diagonally and the sheathing boards provided lateral and sway bracing. The vault and abutments were finished with staff and plaster to represent sculptured masonry.

A park bridge in Buffalo has three skew spans of about 40 feet, each of which has seven plate girder arch ribs with horizontal extrados. Open triangular spaces in the spandrels are filled with ornamental iron scroll work. The arches have a very flat curve and are hingeless. The lower flanges are not braced laterally. The floor projects beyond the outside arch-ribs to form a cornice

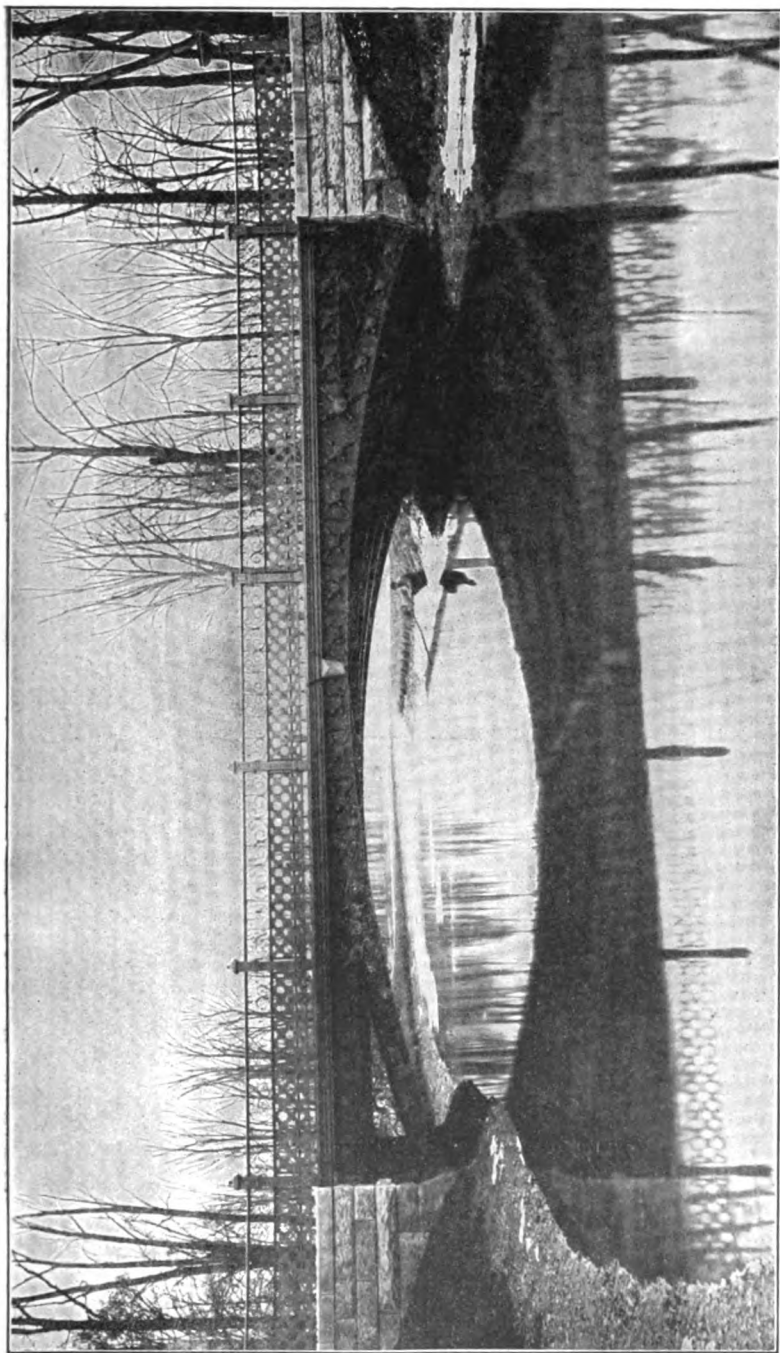

BELLE ISLE PARK BRIDGE, 49-FOOT SPAN.

moulding and is surmounted by a heavy cast-iron hand rail with solid panels. A somewhat similar bridge at Belle Isle Park, Detroit, has five three-hinge plate girder arch ribs of about 49 feet span and  $2\frac{1}{2}$  feet rise on centers. The plate girder panels are ornamented on the outer faces with diagonals of twisted flat bars having cast-iron rosettes at their intersections. The end vertical posts are of cast iron and the spandrel openings are filled with slender wrought-iron scroll work. The bridge has a 24-foot roadway and two 8-foot sidewalks, and was illustrated in "The Engineering Record" of May 13, 1893.

A highway bridge at Belle Isle Park, Detroit, has five three-hinge plate girder arch ribs of about 49 feet span and  $2\frac{1}{2}$  feet rise on centers. The plate girder panels are ornamented on the outer faces with diagonals of twisted flat bars having cast-iron rosettes at their intersections. The end vertical posts are of cast-iron and the spandrel openings are filled with slender wrought-iron scroll work. The bridge has a 24-foot roadway and two 8-foot sidewalks, and was illustrated in "The Engineering Record" of May 13, 1893.

A skew 64-foot span street bridge in Berlin has a 37.4-foot roadway and two 13.5-foot sidewalks carried on longitudinal girders supported by vertical spandrel posts from eleven plate girder two-hinge arch spans. The spandrel posts are 2.37 feet apart on center, and consist of pairs of angles riveted together with tie-plates, making X-shape cross sections, and connected to the arch ribs and longitudinal girders with horizontal bent plate and flange angles. At every alternate panel point the spandrel posts are connected by transverse horizontal struts at top and bottom, and by X-braces, all of single angles. At these points the webs of the arch ribs have vertical web stiffener angles in continuation of the spandrel post angles. The first and second panels on each side of the bridge and the center two panels between arch ribs have lateral X-bracing between the lower flanges of the arch ribs.

The roadway girders are connected by a solid floor of cylindrically curved transverse plates, convex side down, riveted across the top flanges of the stringers and leveled up with concrete to receive the paving blocks. The arch rib webs are 18.4 inches deep at the ends, and 8 inches deep at the crown. Their flange angles vary from 3 x 3 inches at the skewback to 4 x 4 inches at the crown. Cast shoes are bolted to the ends of the ribs and engage the semi-cylindrical surfaces of the hinge bearings, which



are adjustable by bottom and side wedges in the cast pedestals. The arch ribs have rigid butt joints at the crown, spliced with web and flange bolted plates.

The Highway Bridge across the Victoria Gorge, British Columbia, is a plate-girder arch with two ribs of about 25-foot rise and 65-foot span. The ribs are built without hinges, and have on their square ends riveted pedestals seated on the solid rock, which is dressed to surface without masonry piers. The ribs have a uniform depth of about 4 feet, and are braced together by four radial sway frames and by adjustable pin-connected diagonal rods

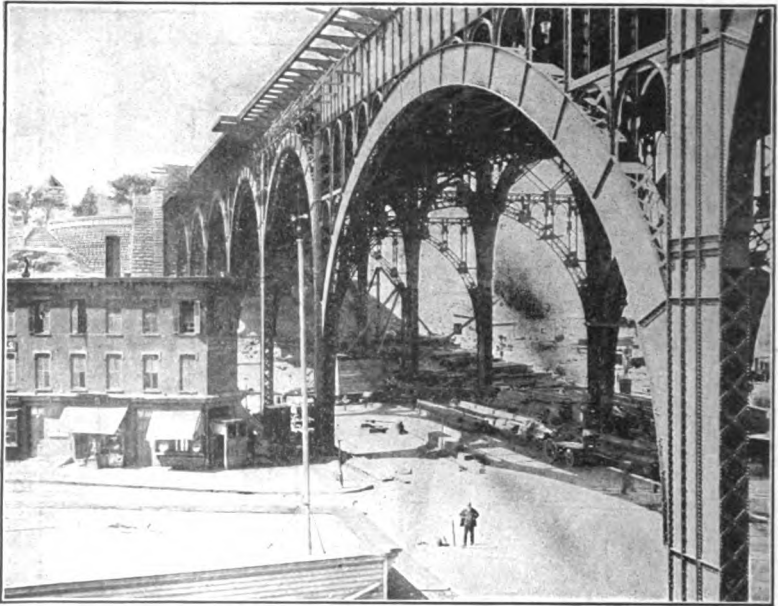

RIVERSIDE VIADUCT, NEW YORK, 128½ AND 65½-FOOT SPANS.

in the planes of the lower flanges. There are five floorbeams, one of which is web-connected to the arch ribs at the crown, and the others are carried on vertical posts at the haunches and skewbacks.

The Riverside Drive viaduct, New York, which was illustrated in "The Engineering Record" of August 25, 1900, has a 60-foot roadway and two 10-foot cantilever sidewalks carried on twenty-two 65-foot and one 130-foot steel arch spans. The solid buckle plate roadway floor is about 80 feet above grade and the superstructure is carried on two lines of main vertical posts 64 feet 2 inches apart. Except those for the large span, these posts

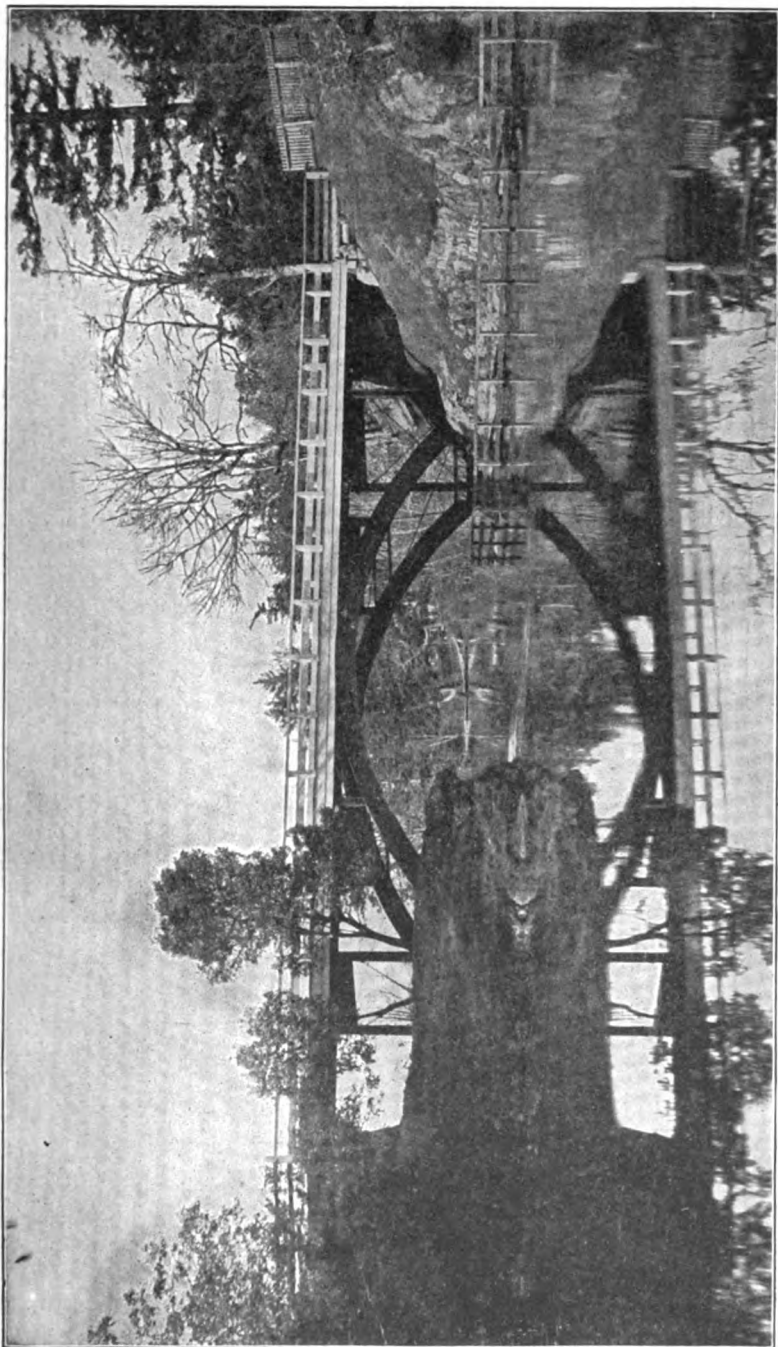

VICTORIA GORGE BRIDGE, 66-FOOT SPAN.

are virtually pairs of vertical plate girders, with 5-foot webs latticed together 2 feet apart in longitudinal planes. Each clear span of 60 feet has two double-web plate girder arch ribs, one in the line of each row of columns. The arches are practically semi-circular with 44-inch webs in the planes of the double column webs. They are made in short, curved sections with radial joints which were all shop riveted. The radius of the end section joint

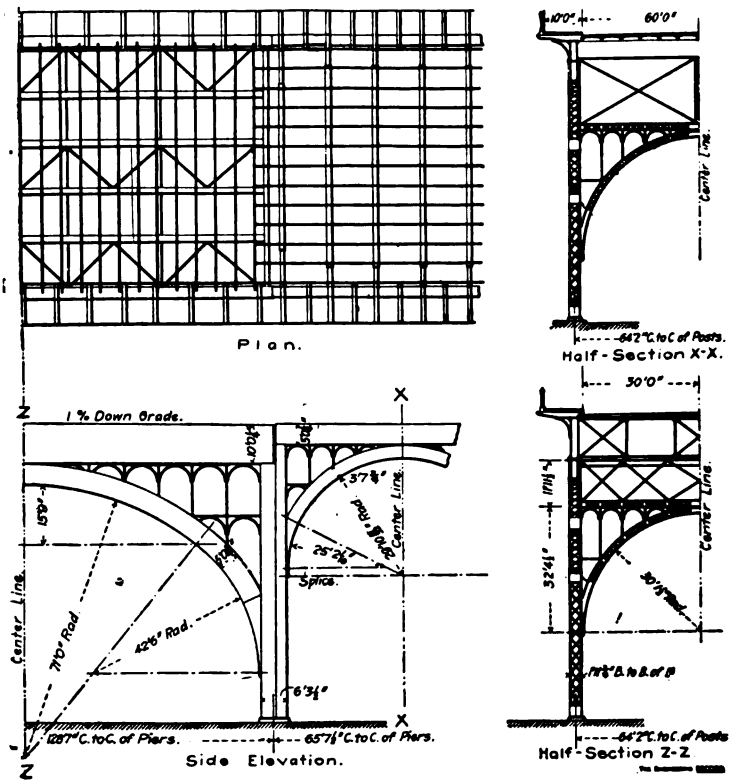

RIVERSIDE VIADUCT.

was drawn from the intersection of the extrados with the edge of the main post, and as the intrados is tangent to the main post at the springing line, the end section is approximately triangular with the extrados vertical, and shop-riveted to the main post, while the radial joint forms the seat for the arch rib.

There is a longitudinal box plate girder seated on the tops of the main posts with the middle of its lower flange tangent to





diagonal angles in the plane of the lower flanges of the longitudinal and transverse girders.

The 130-foot span has a clear opening of 122 feet 3½ inches, and is similar to the 60-foot spans except in the roadway girders. Its arch webs are 60 inches deep, and its longitudinal girder webs, 120 inches deep, are in the planes of the 84-inch webs of the main

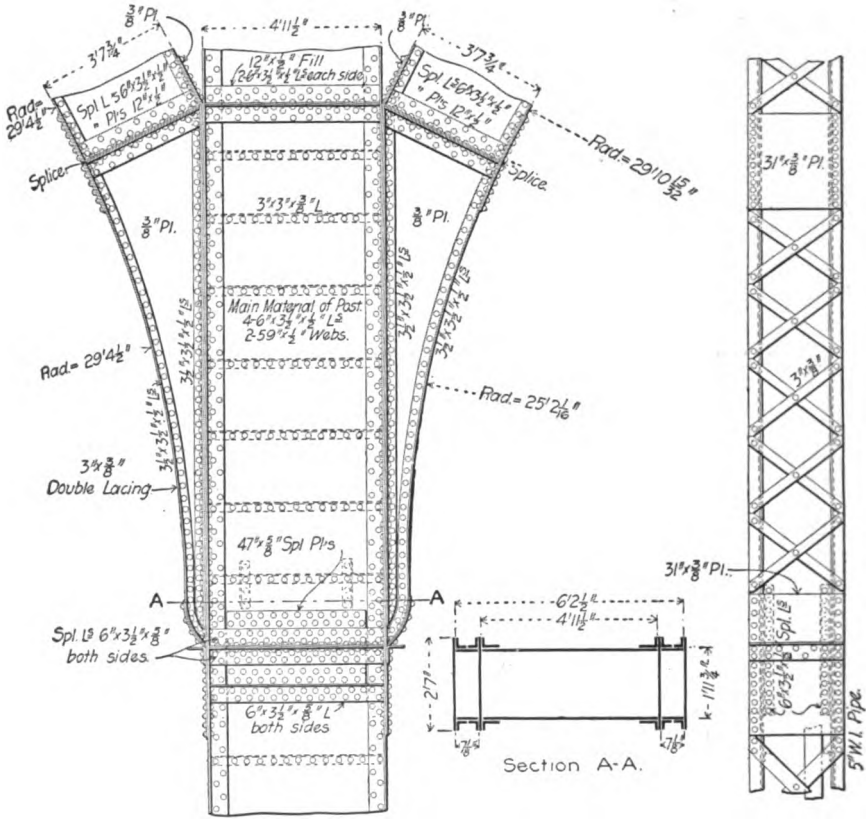

Side Elevation

End Elevation.

Skewback connections for Small Arches.

posts. The longitudinal girders rest on rollers at the expansion end, and are web-connected to transverse girders at both ends. These transverse girders carry four lines of web connected intermediate longitudinal girders which support transverse I-beam roadway joists. Each 65-foot span arch girder weighed 8 tons, and was shipped in two pieces, and erected in one piece. The 130-foot outside longitudinal box girders weighed 62 tons each,

and were shipped whole from the bridge shops. The longitudinal girders were designed to carry all the dead load of the roadway platform independently of the arch ribs, and to deflect so as to be

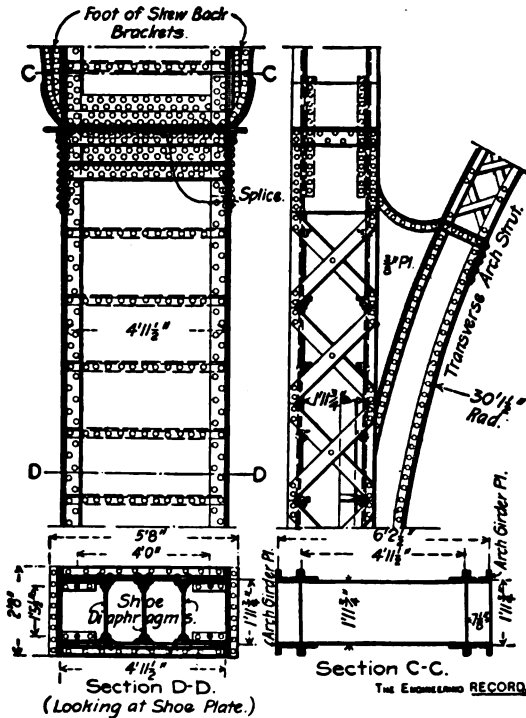

RIVERSIDE DRIVE SKEWBACK CONNECTIONS FOR  
LARGE ARCH AND FOR TRANSVERSE ARCH.

just tangent to them and in contact without pressure at the crown when the finished structure was unloaded.

The Cornhouse Bridge, at Berne, Switzerland, was illustrated in "The Engineering Record" of June 17, 1899, and May 30, 1903, and in the "Genie Civil," December 3, 1898. It has besides the main span, five parabolic side arches of 113½-foot span, and 37¼-foot rise. Each has two box plate girder ribs, connected by tapered transverse struts and supporting spandrel posts and a roadway platform similar to that in the main span. The webs of each girder are about 3 feet deep and 17 inches apart, and are riveted at the ends to solid steel castings, which take bearing on a narrow rounded transverse steel rib on a block seated in a socket in the pedestal and adjustable by two pairs

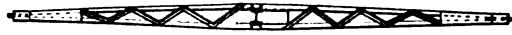
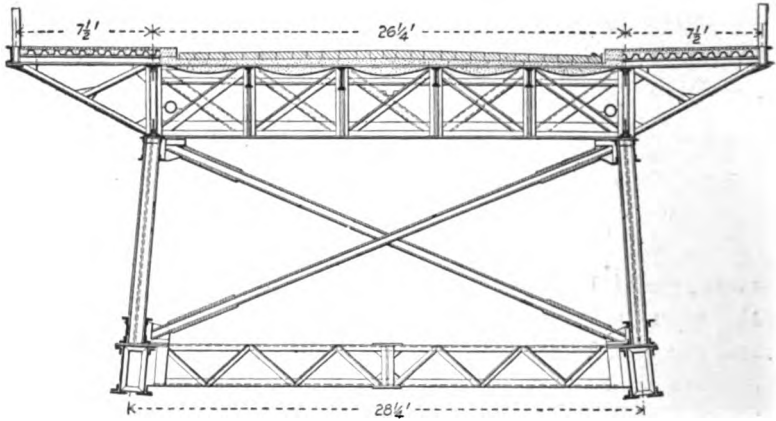

THE ENGINEERING RECORD

CROSS-SECTION NEAR SKEWBACK.

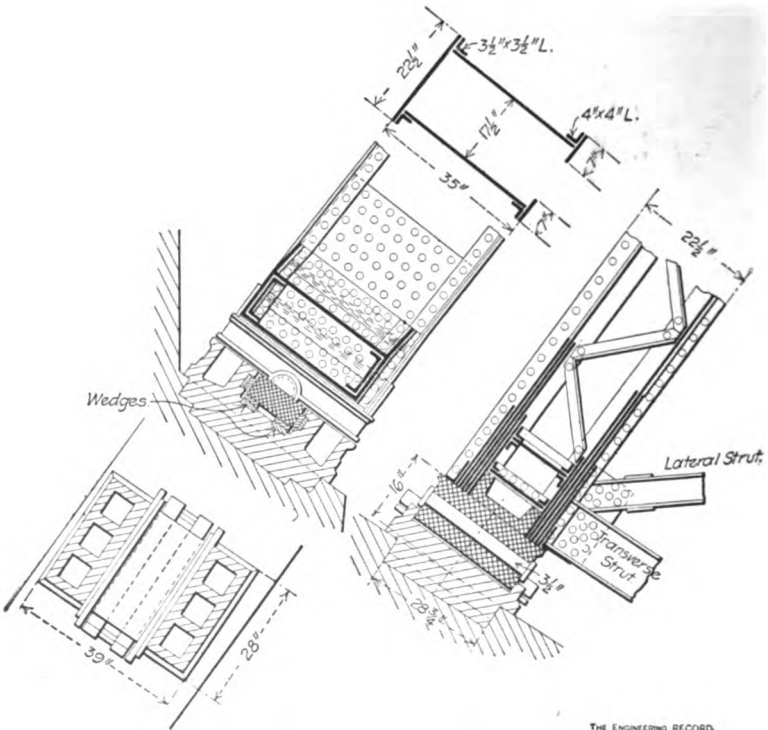

THE ENGINEERING RECORD.

SKEWBACK CONNECTIONS.

of wedges. The pedestal is fitted into a rectangular hole cut into the pier masonry. The bridge is proportioned for a live load of 20 tons, and a wind pressure of 30 pounds per square foot. The

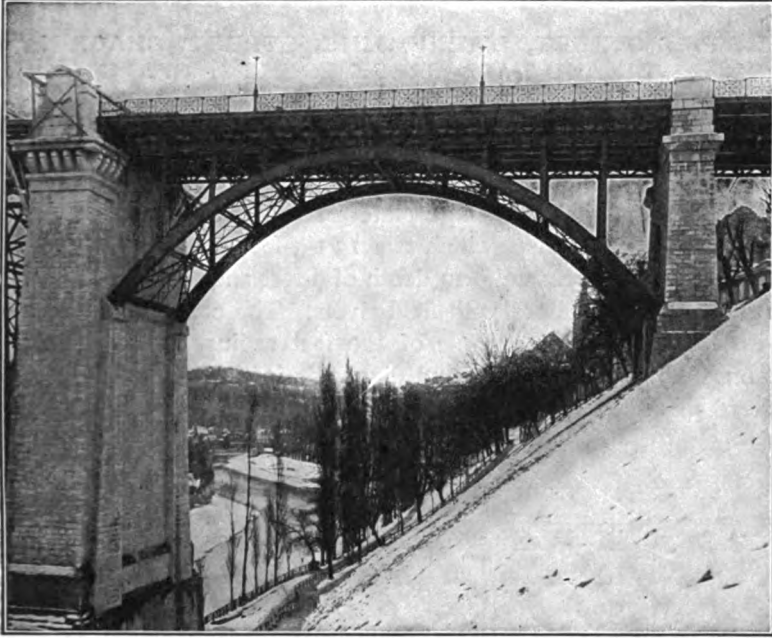

**113½-FOOT SIDE SPAN OF CORNHOUSE BRIDGE, BERNE, SWITZERLAND.**

weight of the main span is very nearly 2,000,000 pounds, the weight of the whole bridge is about 3,000,000 pounds, and its cost in 1897 was \$426,000.

## CHAPTER XV.

### FORBES STREET, MARNE, MILL STREET, CHAGRIN RIVER AND FALL CREEK BRIDGES. SPANS 144 TO 170 FEET.

The new Forbes Street highway bridge, Pittsburg, was described in "The Engineering Record" of July 15, 1899. It has four segmental two-hinge plate girder arch ribs of 144 feet span, and 24 feet rise, which are 13 1-3-feet apart on centers. The arch ribs have a uniform depth of 6 feet and the sections are web and flange spliced with field rivets. The center line of the girders is an arc of a circle of 120 feet radius. The ribs are connected by lateral struts and diagonals in the top and bottom chord planes and by transverse sway brace frames, all made of

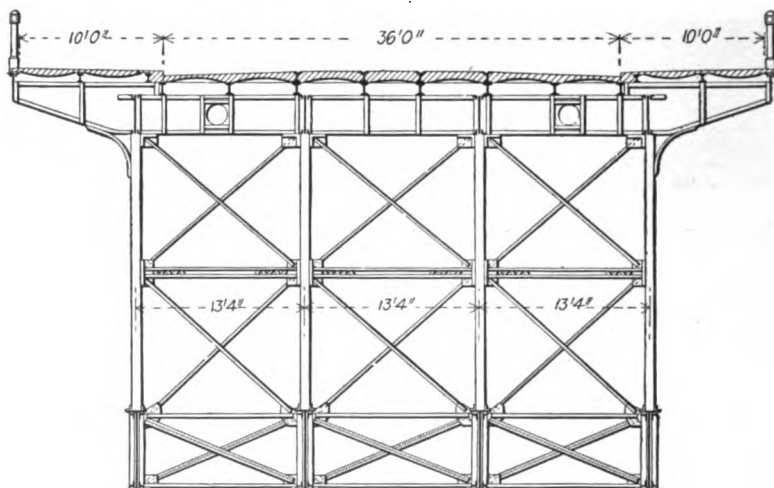

Cross - Section at Panel Point.

The Engineering Record

angles with riveted connections. The spandrel columns, 12 feet apart longitudinally, are seated on the top flanges of the girder ribs, and are connected together by angle X-bracing in the transverse planes. They support plate girder floorbeams 3 feet deep with plate girder sidewalk cantilever brackets about 8 feet

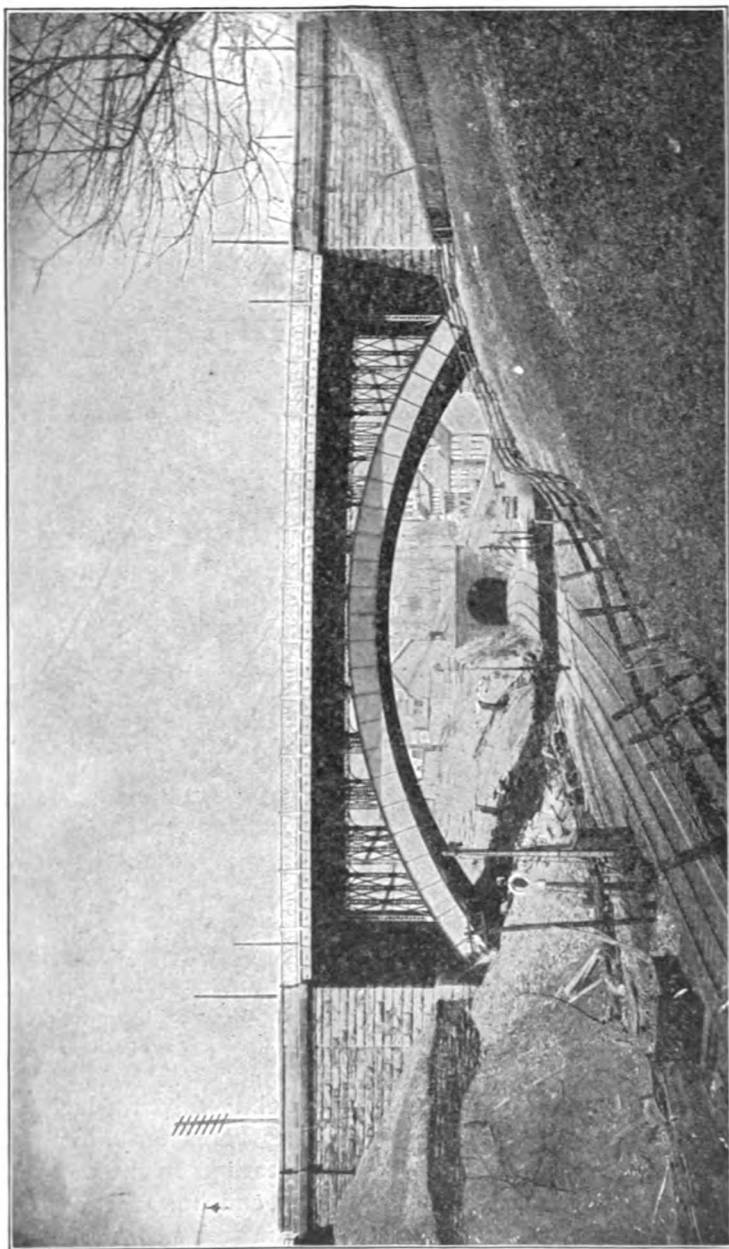

FORBES STREET HIGHWAY BRIDGE, PITTSBURG.

long at each end. The ends of the floorbeams are covered by an ornamental fascia.

The outer rows of spandrel columns each have, at the top, three curved knee braces connecting them to the fascia girders and to the floorbeams. The lower ends of the arch ribs have their webs reinforced to a thickness of  $3\frac{1}{2}$  inches and are bored for double-flange semi-circular cast-steel bushings 24 inches in

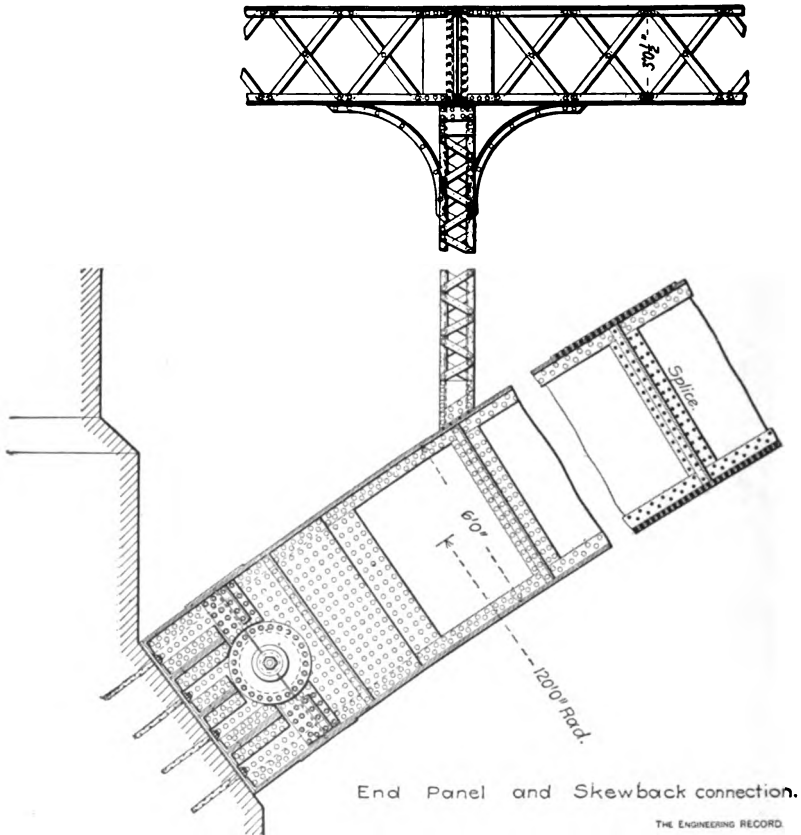

diameter, connected to them by twelve tightly driven 1-inch turned bolts. The bushings have half holes bored for 8-inch horizontal pins, which have corresponding bearings in the pedestals. The pedestals are about 3 feet high and have sections and bushings corresponding to the ends of the arch ribs. They are reinforced by transverse stiffener webs which extend their bases to a width of 30 inches. Their 6 x  $2\frac{1}{2}$ -foot base plates

are normal to the arch curve and are seated on lead plates and bolted to the inclined face of the pier masonry with eight  $1\frac{1}{4}$ -inch rag bolts. The edges of the rib and pedestal webs are planed for  $\frac{1}{4}$ -inch clearance and the joint between them is spliced above and below the bushing by cover plates, which are secured by

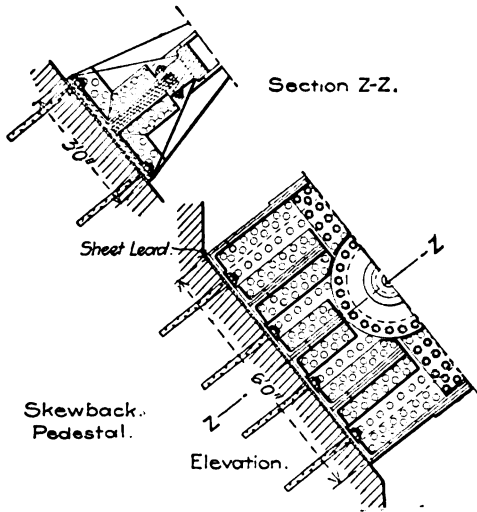

bolts in slotted holes to allow for temperature and deflection movements. The arch ribs were received in three sections each and field riveted with pneumatic hammers. They were erected on trestle falsework with transverse sills and caps, the latter supporting longitudinal stringers, on which the arch ribs were set with double oak camber wedges.

The highway bridge across the Marne, France, is about 531 feet long,  $29\frac{1}{2}$  feet wide and has three segmental plate girder cast-iron arch spans, each with five ribs. The middle span has a clear opening of  $158\frac{1}{2}$  feet and rise of  $13\frac{1}{2}$  feet, with ribs 3 feet deep at the skewback and 2.3 feet deep at the crown. The side span has a clear opening of 132 feet; its ribs have a rise of 11 feet and are  $3\frac{1}{4}$  feet deep at the skewbacks, and  $2\frac{1}{4}$  feet deep at the crown. The ribs are spaced  $7\frac{1}{4}$  feet apart and are made in sections  $13\frac{3}{4}$  feet long, connected together by ten end flange bolts at each radial joint. The outside ribs have a channel-shaped cross-section, richly ornamented with relief figures. The inside webs have I-shaped cross-sections. There is no hinge at the crown, but each rib was erected with an end bearing on a



rounded steel bar set in the middle of the skewback pedestal. As soon as the arch was swung, keys were put in each side of these bars at mean temperature, as shown in the detail.

The roadway platform is supported by vertical cast-iron spandrel posts having ball and socket bearings on the top flanges of the arch ribs, to which they are additionally secured by flange bolts. The tops of these bolts are connected together by solid web cast-iron longitudinal arches bolted on. The ribs are connected by transverse lateral struts and X-braces bolted to the middle of their webs. The former are light plate girders and the latter are single angles. The spandrel posts are connected by

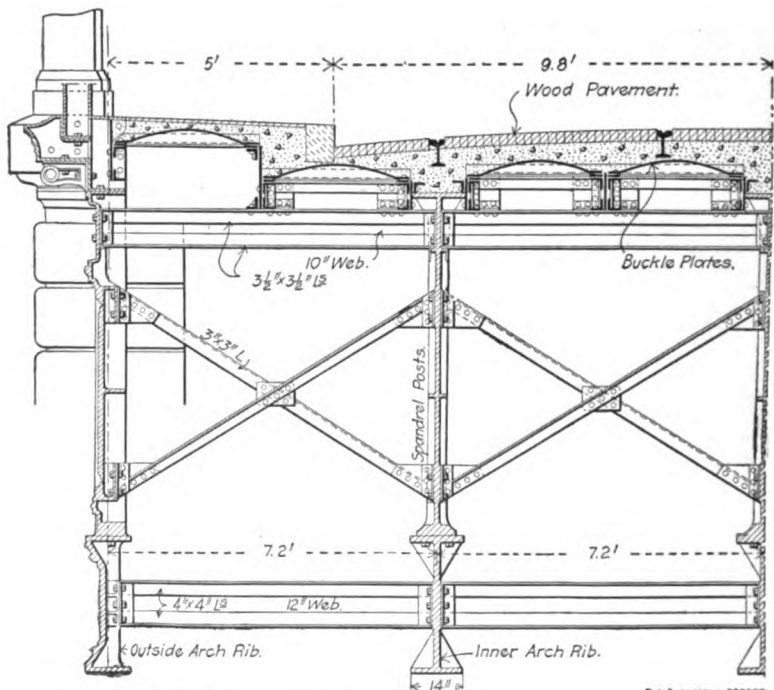

Half Cross-Section near Skewbacks.

vertical transverse X-bracing of single angles riveted to gusset plates bolted to the posts. The riveted plate girder floorbeams and joists carry buckle plates filled in solid with concrete and paved with wooden blocks. Under the expansion ends of the outside ribs there are pedestals sliding in grooved plates, but under the intermediate stringers there are regular castors rolling on abutment plates. The bridge was finished in 1899 at a cost of about

\$144,000. It was described in the "Genie Civil," Paris, of December 9, 1899.

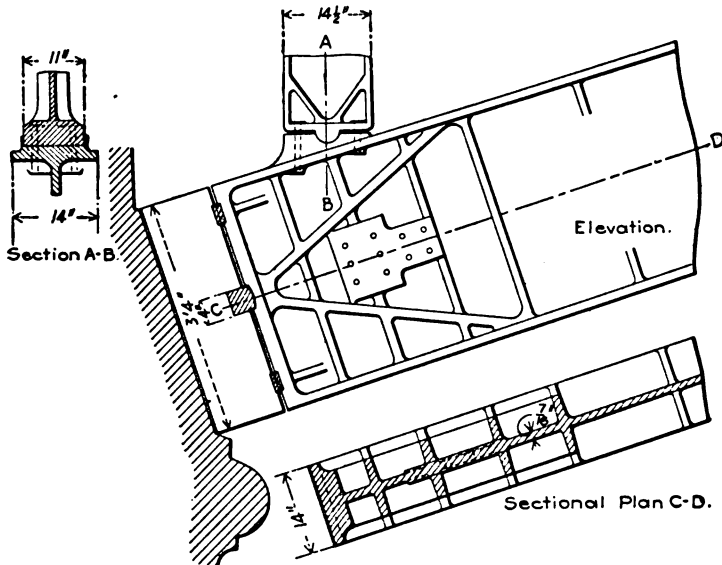

Skewback connections and Pedestal.

THE ENGINEERING RECORD.

The Mill Street highway bridge across the Black River, at Watertown, N. Y., is a 165-foot steel span, with four plate girder three-hinge arch ribs. It was described in "The Engineering Record" of March 5, 1898. Each rib has a rise of  $15\frac{1}{4}$  feet with a horizontal top flange and polygonal bottom flange, corresponding to the chords of a circular segment. The rib is 5 feet deep at the crown, with a solid plate web for the middle 100 feet, and two panels of a riveted truss at each end. Each rib is in two sections, united in the middle by an 8-inch pin through jaw plates in the top chord, and by double web splice plates below the pin. The jaw plates are reinforced by longitudinal angles, which also distribute the strain over a larger part of the web and chord. The ends of the T-shaped lower chord have bearings on 8-inch pins in a double web pedestal, with transverse stiffening diaphragms, which is set on the inclined face of the abutment masonry. The ribs are 9 feet 2 inches apart, and are connected together by six sets of transverse bracing, and by the floor-beams with deep knee braces.

There is lateral bracing in the planes of the lower chords

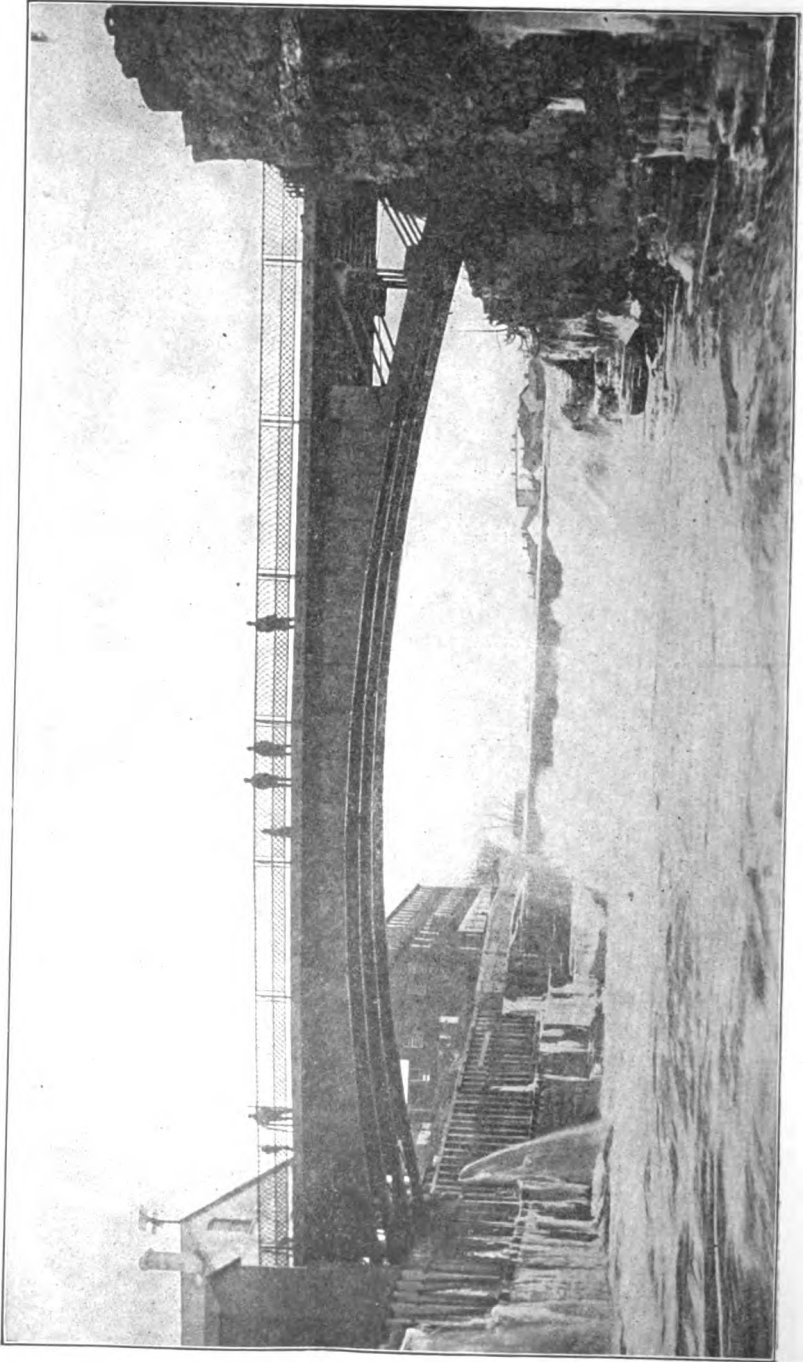

MILL STREET BRIDGE, 166-FOOT SPAN.





end panels were all shipped separately and riveted together in the field on falsework, which was trussed to span a clear width of 99 feet over violent rapids at the foot of a fall. The bridge is proportioned for a dead load of 5667 pounds per linear

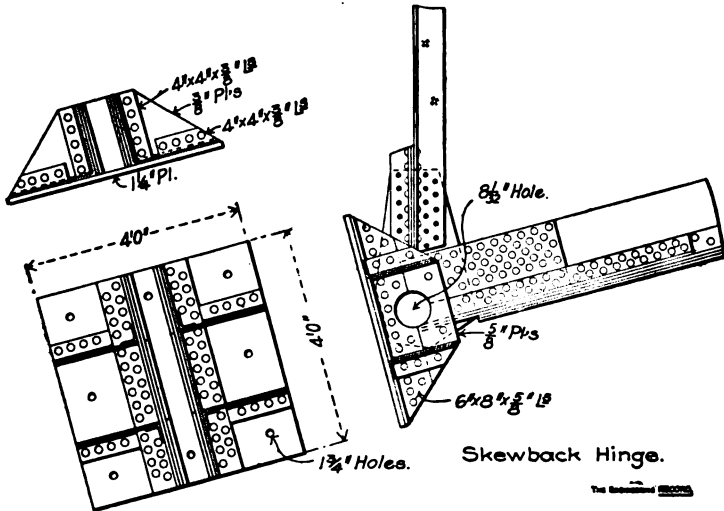

foot, a distributed live load of 3320 pounds per linear foot and a concentrated load of 50,000 pounds on two axles of 11 feet apart.

The Chagrin River highway bridge, at Bentleyville, Ohio, has a main span with two two-hinge plate girder arch ribs of 168 feet 9 inches span and  $29\frac{1}{2}$  feet rise, 27 feet apart on centers. The radial depth of the ribs varies from 4 feet at the crown to 6 feet at the skewbacks. Each rib is made in twelve sections, spliced with web and flange cover plates and rivets through the flanges of the end web stiffener angles. The web has a uniform thickness of  $\frac{3}{8}$  inch, and is divided into panels about 4 feet long by pairs of crimped radial web stiffener angles. The center line of the web is the arc of a circle; the upper and lower edges and flange angles are cut and bent to straight lines between panel points so as to be chords of 4-foot arcs of circles parallel and concentric with the arch circle. The angles between adjacent portions of the flanges are so small that they are imperceptible, and the effect is of a continuous segmental curve. At the skewbacks the flange angles are curved to intersect on the center line of the web at the hinge pins, although the web is extended outside them to its full width to

continue the chord lines to the masonry. The web is cut off radially on the pin centers, and is stiffened there with four radial angles riveted together back to back parallel with the face of the skewback masonry. The outer pair of angles are about  $\frac{1}{2}$  inch apart in the clear so as to form jaws engaging the center web plate in the pedestal, to which they are bolted through slotted holes which allow for deflection movements, also provided for by the clearance between the girder and the ends of the webs. The webs are reinforced to a thickness of  $3\frac{3}{4}$  inches for bearing on the

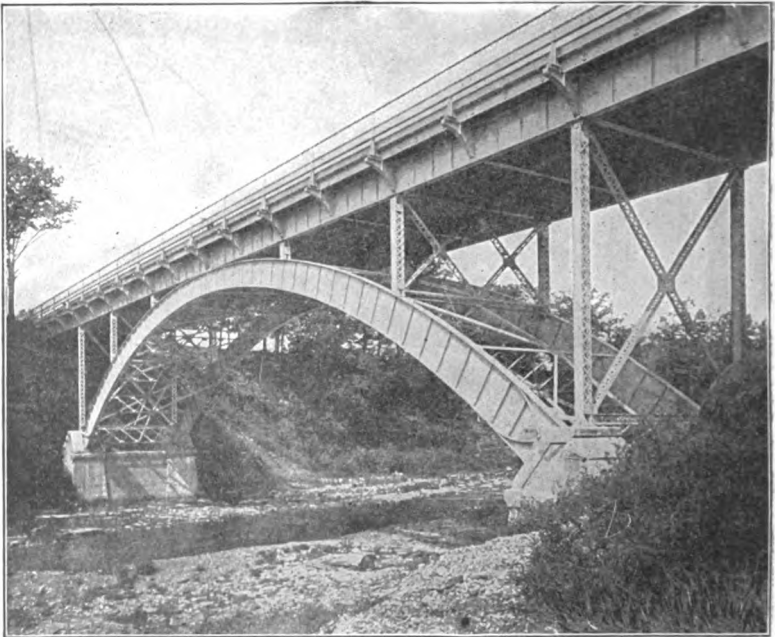

THE CHAGRIN RIVER HIGHWAY BRIDGE, 116-FOOT 9-INCH SPAN.

10-inch hinge pin, which is seated on the double main webs of the pedestal. The pedestal has a  $2\frac{1}{2} \times 6$ -foot base seated on a  $\frac{1}{4}$ -inch lead bearing plate and anchored to the masonry with four 2-inch bolts. The arch ribs are connected by thirteen radial sway brace frames made with horizontal top and bottom flange angles and double panels of X-bracing, and there are X-brace laterals reaching across two panels of the sway bracing in the planes of the top and bottom flanges. The brace angles are single or double 3 x 3-inch or 3 x 4-inch angles.

The arch ribs carry six horizontal longitudinal 30-foot plate





inch I-beam channel stringers are seated across the top flanges of the floorbeams and are raised on fillers and bent plates to secure the roadway crown. The stringers are covered with buckle plates, convex side down, filled with concrete and paved

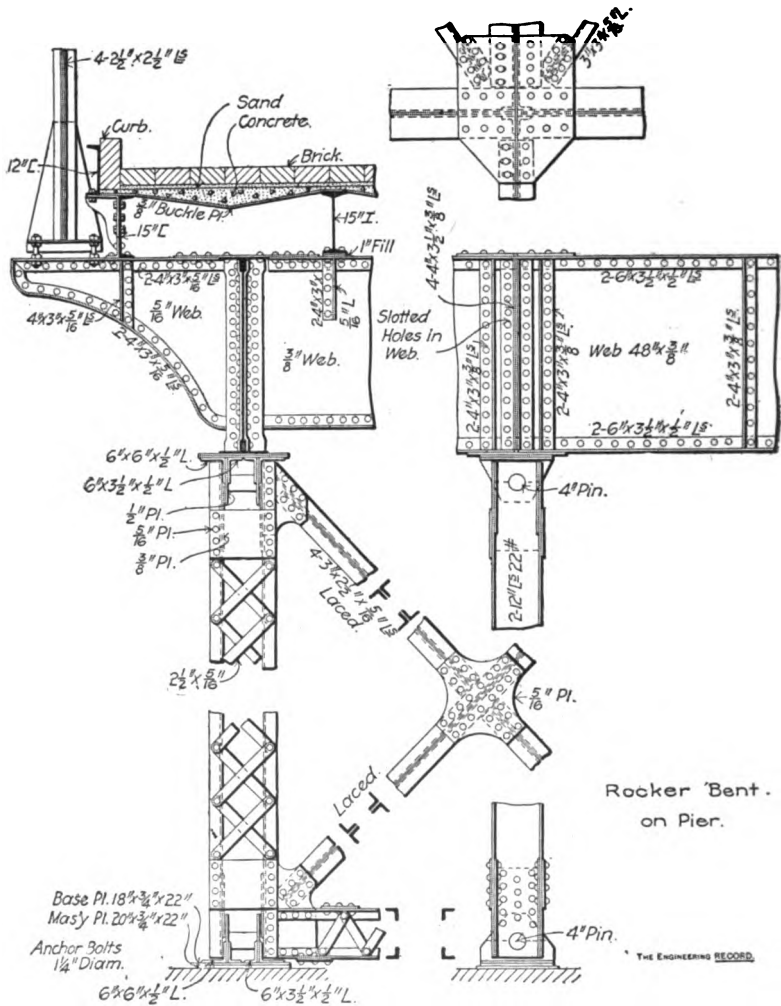

with stone blocks. The roadway has a clear width of 32 feet and is protected by a very heavy latticed hand-rail 3 1/2 feet high, which has posts made of four angles riveted together back to back with vertical transverse web plate having extended flange angles forming a wide base bolted to the top flange of the floorbeam.



The Fall Creek highway bridge, Ithaca, carries the highway and sidewalks across a deep chasm between the Cornell University campus and a residence district chiefly occupied by professors' houses. The site is a very beautiful and romantic gorge, with vertical sides of solid rock about 150 feet high, which

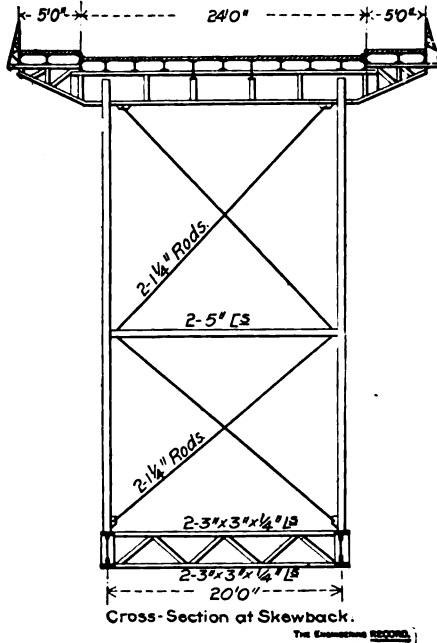

afforded excellent foundations to resist lateral thrust, and so an arch span was selected to utilize the natural abutments for the reactions. There are two two-hinge plate girder arch ribs of 170 feet span and 34 feet rise, 20 feet apart on centers. Each rib has a 60 x 7-16-inch web throughout, and is made in nine straight sections conforming to chords of the circular segment of its center line. The sections are spliced by double web cover plates shop-riveted to one section to form jaws to receive the adjacent section, which, with the flange cover angles and plates, are field-riveted. The ends of the webs are reinforced to a total thickness of about  $2\frac{1}{4}$  inches for bearing on the 8-inch skewback pins, to which the flange angles are bent to converge. The bearing is with a half hole except for the outside plates, which project to form jaws, locking the rib to the pedestal, which has double outside webs with transverse stiffening diaphragms.

The arch ribs are sway braced by lattice girder struts in radial planes, field-riveted to the web stiffener angles at splice points, and the panels thus formed with the top flanges are X-braced



THE FALL CREEK STREET CAR BRIDGE, 170-FOOT SPAN.

with pairs of 2 x 3-inch lateral angles riveted together back to back to make T-shaped cross-sections. These angles are riveted across the girder flanges and to connection plates at their intersections where one pair is continuous and the other pair is cut to

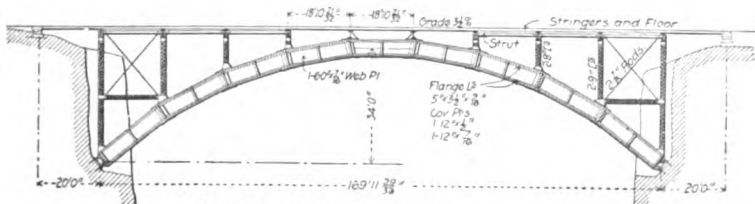

Elevation of Arch Rib and Spondrel Bracing.

FALL CREEK BRIDGE.

THE ENGINEERING RECORD

clear, and there is a transverse angle strut to stay them. The vertical spandrel posts have oblique shoes riveted to the top flanges of the arch ribs, and are of different lengths to conform to the roadway grade. They are pairs of latticed channels with webs perpendicular to the bridge axis.

The floorbeams pass through the posts, and are seated on horizontal shelf angles riveted to the top tie plates some distance below the upper ends of the spandrel posts. Just below its top flange the floorbeam is web connected to tie plates at the top of

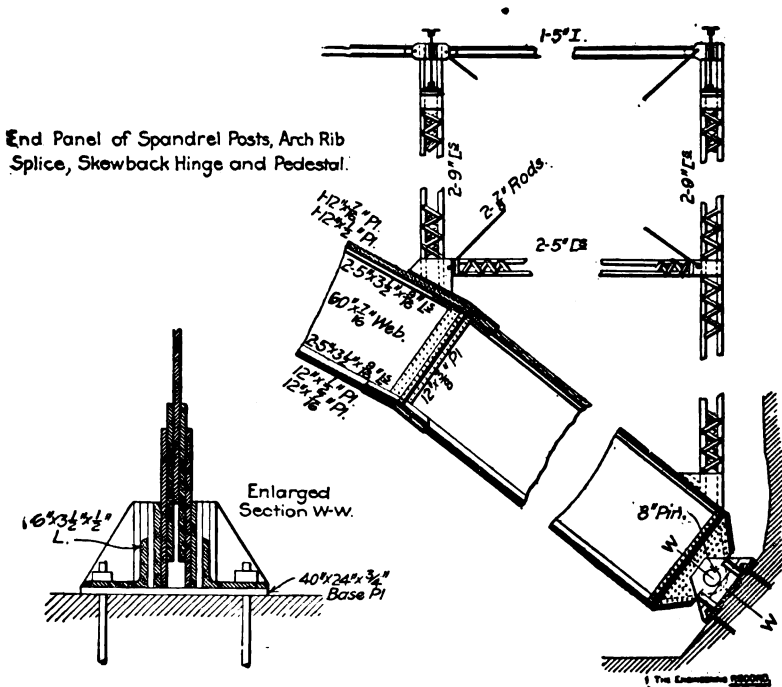

the spandrel post, which project beyond its flanges and form wing plates for the pin connections with longitudinal I-beam struts. The spandrel posts are sway braced with pin-connected sleeve-nut rods. The floorbeams are 30 inches deep and 34 feet long over all, with cantilever sidewalk extensions, and are X-braced with single 3 x 2-inch lateral angles in the plane of the bottom flanges. There is a 3-inch plank floor carried on longitudinal I-beam joists 9 inches deep, except for the two center lines, which are 15 inches deep, to provide for the street car track.

The bridge is proportioned for a live load of 2400 and a

dead load of 1600 pounds per linear foot. These produce maximum horizontal and inclined reactions at the skewbacks of 180,500 and 234,000 pounds, respectively, and flange stresses of 147,000, 199,840, 200,800 and 153,560 pounds in the flanges of the respective panels from the skewbacks to the crown. The bridge was erected on trestle falsework, and the skewback seats were not set until the horizontal distance between them was checked by measurement with a steel tape across the falsework.

A cast-iron arch bridge at Rochester, England, was described in "The Engineering Record" of April 11, 1896. It had one 170-foot and two 140-foot spans, each with eight cast-iron plate girder ribs having a rise of one-tenth the span. The center span had six segments with radial flange joints planed and secured with four  $2\frac{1}{2}$ -inch bolts. There was no complete lateral system, but there were cast-iron sway brace frames. The granite pavement was laid on 3-inch planking supported by cast-iron floor troughs with rust joints. A barge collided with the center span and broke out large portions of the two outer ribs, weighing about 23 tons, but the paving blocks and floor troughs arched over the opening and carried the traffic for some time. The incident showed the danger of instant destruction of a cast-iron bridge by an accident which might at any time occur, and would not be likely to have nearly as serious results with a steel bridge, which would yield and stretch and bend, instead of breaking under impact or sudden stress.

## CHAPTER XVI.

### NORTH AND FERN HOLLOW BRIDGES. SPANS 175 AND 195 FEET.

The North highway bridge over the Waverly station of the North British Railway, Edinburgh, Scotland, has a steel superstructure about 85 feet in extreme width and 561 feet long between abutments. It was described in the "Engineering," London, October 6 and 20, 1899. The granite pavement is set on a concrete bed on brick arches sprung between the webs of transverse I-beam

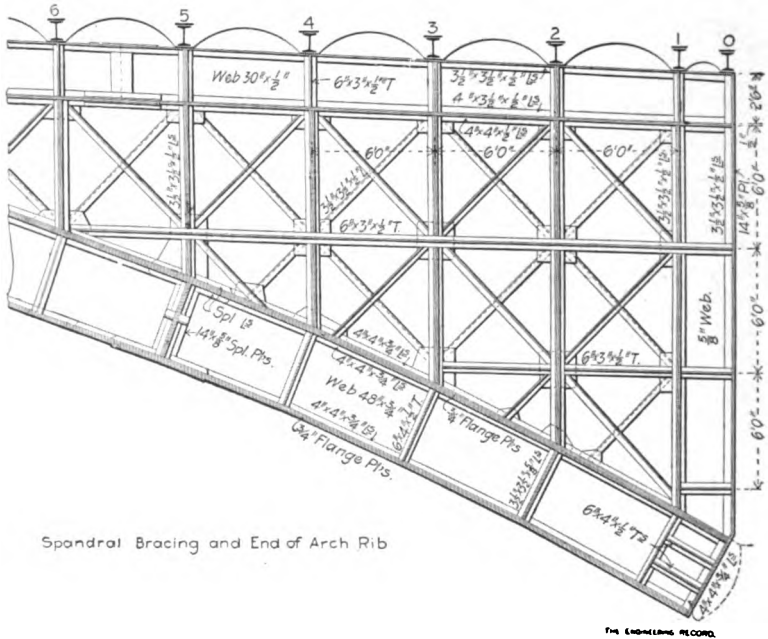

Spandrel Bracing and End of Arch Rib

floor joists 6 feet apart, which are carried on six lines of main longitudinal plate girders 30 inches deep, each of which is supported by vertical spandrel posts 6 feet apart longitudinally and 14 feet 8 inches apart transversely. The spandrel posts are seated on the ribs of three 175-foot two-hinge plate girder arch spans carried on brick piers 18½ feet thick. The six ribs in each span are in the

vertical planes of their respective horizontal roadway girders, and have a rise of about 22 feet and radius of intrados of  $185\frac{1}{2}$  feet.

The arch ribs have a uniform section throughout, consisting of a  $48 \times \frac{3}{4}$ -inch web, four  $4 \times 4 \times \frac{3}{4}$ -inch chord angles, and four

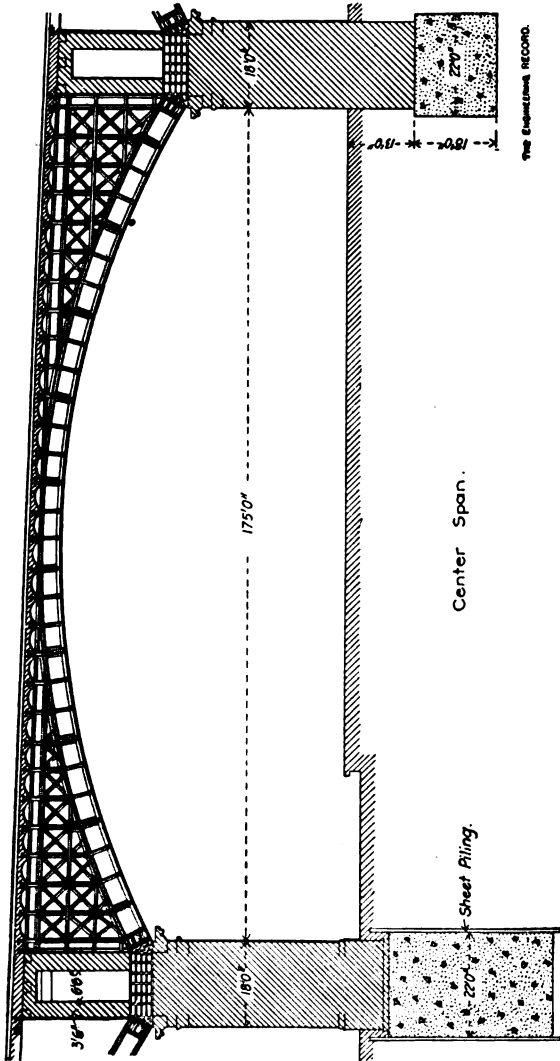

NORTH BRIDGE, WAVERLY STATION, EDINBURGH.

$21 \times \frac{3}{4}$ -inch chord flange cover plates, besides two  $4 \times 4 \times \frac{3}{4}$ -inch angles riveted to the upper side of the top flange to receive the spandrel bracing connections between the haunches and the skew-



backs. Each rib is divided into panels by radial web-stiffener angles and tees, and is made in six curved segmental sections weighing about 19,000 pounds each and having planed radial

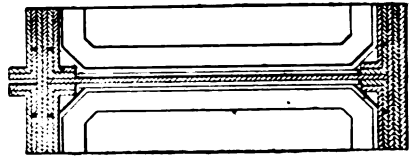
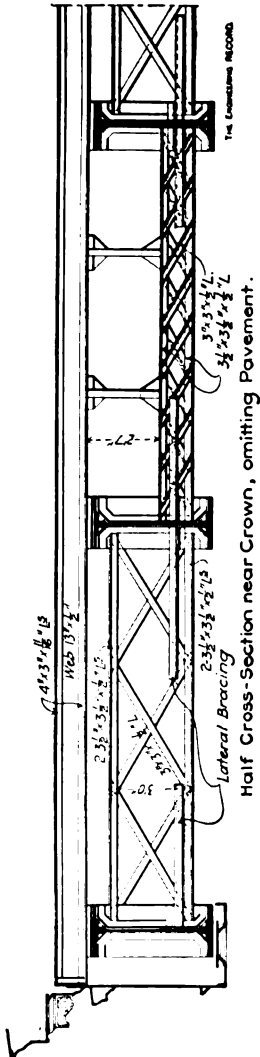

Section of Main Girder at Haunches.  
The Lanchester RECORD

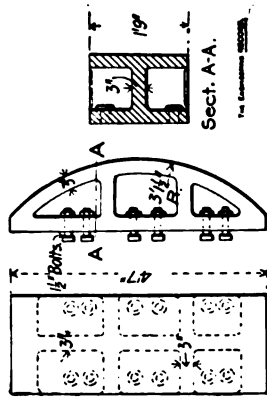

Skewback Bearing.  
The Lanchester RECORD

flange joints. The ribs are spliced with double web plates and wide double-flange cover angles, as seen in the cross-section, which also shows the typical English way of bending the ends of the web-stiffener angles and riveting their horizontal extremities

to the flanges. The splice rivets were all driven in the field, those in the flanges by machine, and those in the webs by hand.

The short end panels of the ribs are reinforced by longitudinal web-stiffener angles, and are flange-bolted to cast bearing pieces with convex cylindrical bearings to engage concave ribbed surfaces in very large cross-webbed skewback castings, which have horizontal seats on the substructure masonry. Each of these pier castings is 19 feet long, 39 inches wide, 4 feet  $7\frac{1}{2}$  inches high, and weighs 13 tons. They pass entirely through the pier masonry, and receive the ends of the ribs in the adjacent spans at their opposite ends. The abutment castings have, of course, only one girder bearing each, and are about one-half as long and heavy as those on the piers.

The lower end of a vertical plate girder with a 30-inch web

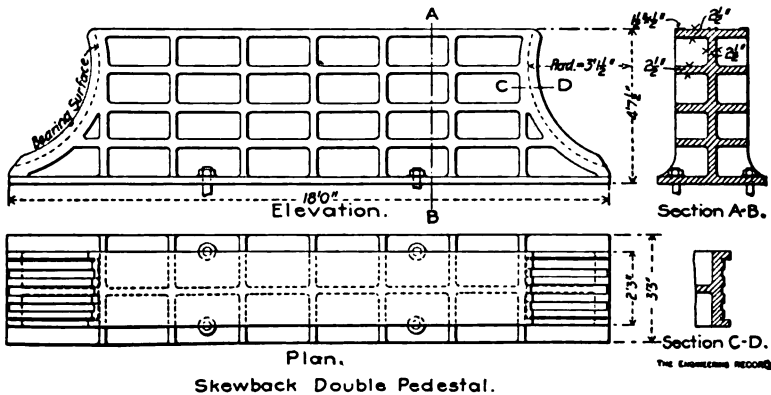

in the plane of the webs of the arch rib and the corresponding roadway girder, is riveted to the extrados at the skewback, and forms a column whose upper end supports the end of a longitudinal line of roadway girders independently of the pier masonry, and is rigidly riveted to it. The opposite end of the line of roadway girders is beveled to fit the curve of the arch rib, on the upper flange of which it is seated. Horizontal struts divide the longitudinal spaces between the spandrel posts into 6-foot squares, each of which is X-braced by a pair of  $3\frac{1}{2} \times 3\frac{1}{2} \times \frac{1}{2}$ -inch angles. The six spandrel posts in each transverse row are connected together by horizontal struts and sway brace diagonals, and the arch ribs are connected at splice points by transverse lattice girders 30 inches deep, between which are lateral X-brace angles. All diagonals are stiff members, and all connections are riveted. The out-

side girders and spandrels are masked by ornamental steel and cast-iron plates and pilasters.

There is only a single set of lateral angles and X-brace angles, and that is peculiar for being in the plane of the center line of the arch ribs. In the two panels adjacent to the center panel in the transverse section of the bridge, the sway bracing is omitted between the longitudinal roadway girders, and the spaces thus left clear are utilized to carry several lines of electric conduits, gas and water mains. The skewback seats of the successive piers vary 7.15 feet in height to correspond with the grade of 1:27. The

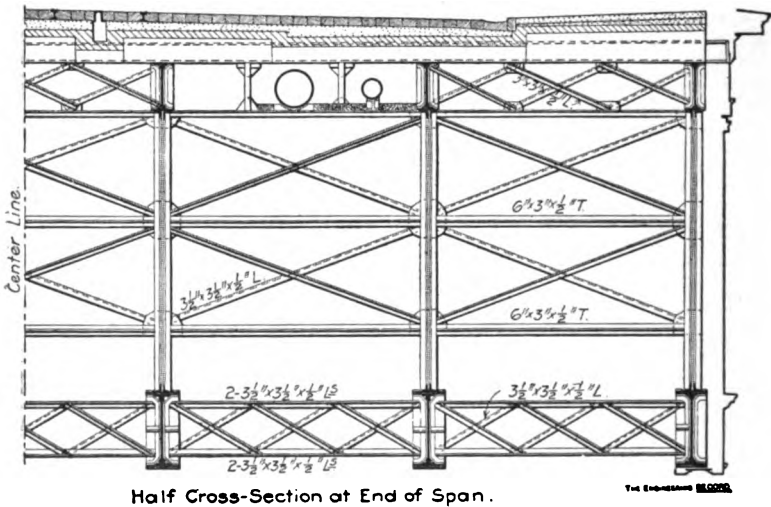

ends of the arches are thus at different heights, and each pier skewback supports the high end of the low arch and the low end of the high arch at the same level. The skewbacks were set in grout and secured by anchor bolts 6 feet long. The arch segments were assembled on falsework bents irregularly spaced to clear obstructions. The convex girder bearings were wedged to position in the skewback seats and after the arch ribs were adjusted the wedges were replaced at one end only, by sectional steel shims, from 9-16 inch to 1 $\frac{1}{8}$  inches thick, planed to fit.

In February, 1900, the Councils of the city of Pittsburg appropriated \$100,000 for the construction of a street railway and highway bridge on the line of Forbes street, across Fern Hollow, which was described in "The Engineering Record" of Feb. 15, 1902.

Ground was broken for the foundations on July 12, 1900, and the bridge was accepted and final payment made Sept. 28, 1901. Street car service across the bridge had been previously commenced on

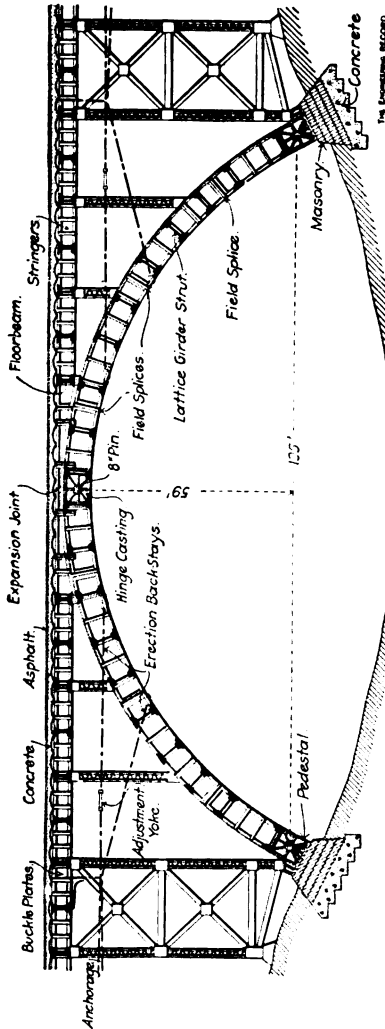

LONGITUDINAL SECTION OF FERN HOLLOW BRIDGE, SHOWING ERECTION BACKSTAYS.

July 3, after having been maintained across the Run for six months on an adjacent temporary wooden trestle viaduct.

The bridge is a deck structure on a grade of 3.335 per cent, and is about 438 feet long and 50 feet wide over all. It carries a 36-foot roadway, two 6½-foot sidewalks, and provisions are made

for carrying two 16-inch gas and two 16-inch water mains. It is about 94 feet high above the ground in the lowest part of the valley. At about the middle of the structure there is a 195-foot main span, with two three-hinge plate-girder arch ribs, and vertical spandrel posts 24 feet apart, supporting the roadway deck. At each end of the arch span there is a viaduct tower with four vertical posts, and between each tower and the adjacent abutment there are four plate-girder approach spans of about 24 feet, supported on three intermediate trestle bents, with two vertical posts each. The bracing is composed of angles calculated for both tension and compression stresses, and all connections are riveted except the arch hinges. The skewback and viaduct posts all have separate masonry piers with Lehigh Portland cement concrete footings, offset 4 or 5 feet below the surface is very hard, solid shale rock.

According to the standard requirements for Pittsburg bridges and viaducts, the structure was proportioned for a load of 65 pounds per square foot of floor surface, including sidewalks, or for a concentrated load of 30,000 pounds on four wheels, 8 feet between axles and 5 $\frac{1}{2}$ -feet gauge, on any part of the roadway floor, or for a concentrated load of 30,000 pounds on four wheels 8 feet apart between axles, on each street railway track. The bracing is proportioned for a horizontal transverse live load of 50 pounds per square foot of side elevation of the structure, taken for one surface only, as for single stringer or arch rib.

In the flanges of the I-beam stringers, plate girders and plate-girder arch ribs, the allowed tension per square inch of net section is 8000 pounds for live loads and 16,000 pounds for dead loads. In the girder webs and connections the shear per square inch is 6000 pounds for live load and 12,000 pounds for dead load. In the bracing a tension of 16,000 pounds per square inch of net section is allowed. In the arch-rib flanges, and for bracing, the allowed compression per square inch is 8000 pounds for live loads and 16,000 pounds for dead loads. Rivets are proportioned for unit stresses of 6000 and 10,000 pounds, respectively, in shearing and bearing for live loads, and for twice as much for dead loads. One-fifth more rivets are used for field-driven connections than are required by these values. No compression member is more than 125 times as long as its least radius of gyration, and all compression flanges of plate girders have the same cross-section areas as the corresponding tension flanges. Members subject to alternate tension and compression, or to combined

tension and bending, are proportioned for each of these stresses separately, and the cross-sectional area of the member is made equal to the sum of these cross-sectional areas. The compression in pounds per square inch for the cast-steel shoes and bearing plates is  $12,000-60 L \div R$  for live loads, and twice as much for dead loads. For cast-steel pin bearings, 12,000 pounds and 24,000 pounds per square inch are allowed for live and dead loads, respectively. For bearings on Portland cement concrete and sandstone masonry a pressure of 250 pounds per square inch is allowed.

The arch ribs are curved plate girders,  $6\frac{1}{2}$  feet deep and 36 feet apart on centers, with a rise of 59 feet between centers of crown and skewback pins. They are made in sections from about

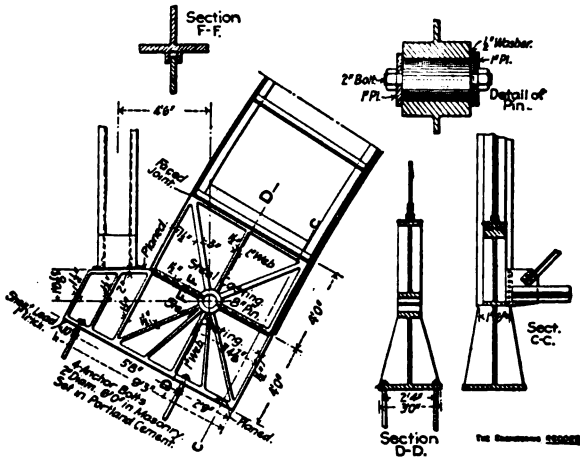

SKEWBACK HINGE AND PEDESTAL.

17 to 21 feet long, with faced radial butt joints spliced with double web-covered plates having 66 rivets in three rows on each side. There are six sections in each semi-arch, the skewback and crown pieces being shipped in single lengths, and the four intermediate sections being shop-riveted together in double lengths, making eight shipping pieces in each complete arch-rib. The web is uniformly  $\frac{3}{8}$  inch thick, except in the skewback panels, where it is reinforced by two 7-16-inch plates, and the flanges are each composed of two 6 x 6 x  $\frac{3}{4}$ -inch angles and 20-inch cover plates. The top flange has a single  $\frac{3}{4}$ -inch cover plate from end to end, and the bottom flange has single  $\frac{5}{8}$ -inch plates at the crown, two at the haunches and three at the skewbacks. There are 5 x 3 $\frac{1}{2}$  x  $\frac{3}{8}$ -inch web-stiffener angles from 5 $\frac{1}{2}$  to 6 $\frac{1}{2}$  feet apart, which consist

of single angles and fillers on opposite sides of the web, except at spandrel-post points, where there are double pairs of angles, back to back.

The lower ends of the ribs are cut off square on radial lines, and have web-stiffener flange angles riveted to the cast-steel hinge plates; these are also riveted between the projecting flange plates, which extend like jaws, 4 feet beyond the ends of the ribs. At the upper ends the ribs are similarly connected to the cast-steel

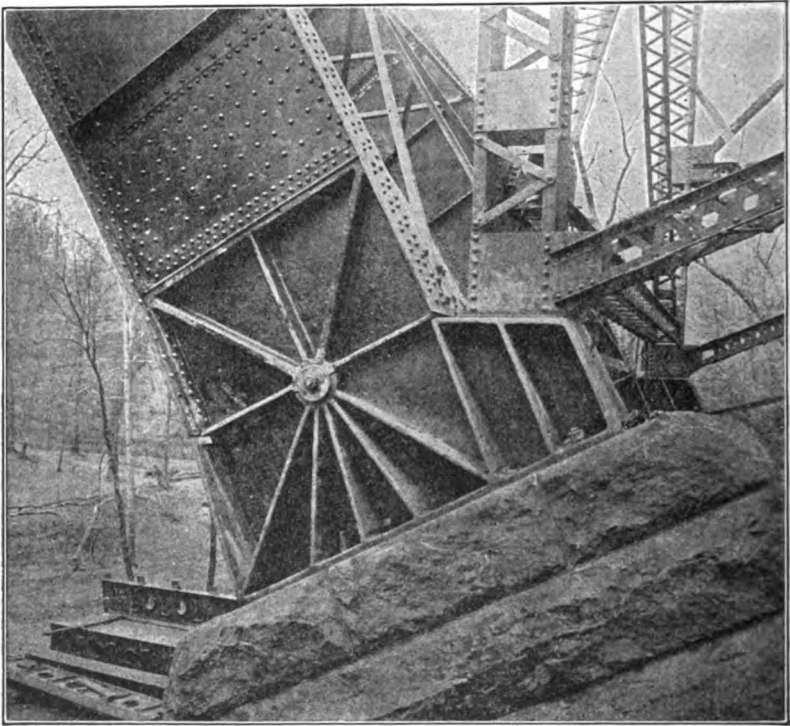

SKEWBACK HINGE AND PEDESTAL.

crown hinge plates. The rectangular hinge plates are 4 feet long and  $6\frac{1}{2}$  feet high, with a 1-inch web and 12-inch flanges on all sides. There is a hub 14 inches in diameter and 12 inches thick, which is bored for an 8-inch pin and stiffened by transverse diaphragm webs to the middle and ends of the bearing for the arch rib. The skewback castings are similar to the hinge castings, except that they have two additional diagonal stiffening webs to distribute the load over the bearing flange, 3 feet wide and  $9\frac{1}{2}$  feet long, which

is seated on the inclined masonry surface radial to the arch curve, and has an extension serving for a pedestal for the adjacent tower post. At each hinge both castings have semi-cylindrical pin bearings, and there is about  $\frac{1}{2}$ -inch clearance between the castings on each side of a radial line through the pin center. The web of one casting, beyond the hub, fits between two projecting flanges like a double web, on the end of the opposite casting, thus forming a closed joint to protect the clearance and exclude the weather. The

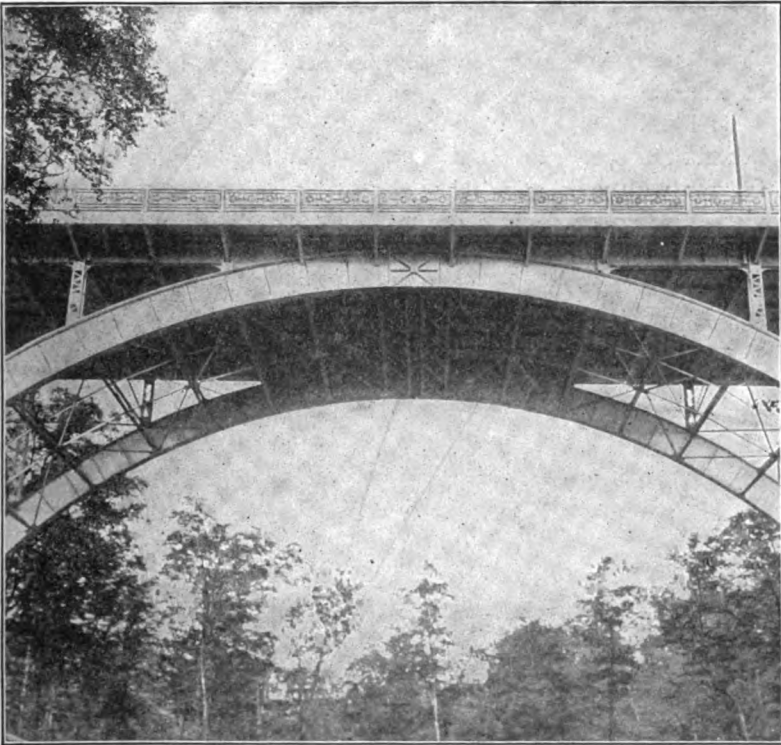

VIEW OF LATERAL BRACES.

hinge pins are cut off flush with the ends of the hub, and are secured in place by 10-inch steel disks 1 inch thick, covering the ends and part of the hubs, and held in place by a 2-inch bolt through the center of the pin. One disk has a  $\frac{1}{2}$ -inch annular washer between it and the end of the hub to allow for any excess in the length of the pin.

The arch-rib girders are braced with eighteen horizontal struts, in radial planes at equal horizontal distances apart except at the



crown, where the two center struts are very close together, and at the skewbacks, where the last two struts are further apart than the intermediate ones. The struts are latticed girders of the same depth as the arch ribs and have top and bottom flanges made of pairs of 3 x 3-inch or 4 x 3-inch angles riveted together back to back, with single X-brace angles for web members. They are attached to the top and bottom flanges of the arch ribs by connection plates shop-riveted to the flanges of the struts and field-riveted to the girder flange cover plate outside the flange angles. The top and bottom flanges of the arch ribs are X-braced by single 4 x 3 x 5-16-inch lateral angles, each crossing two panels of transverse struts and stiffened at intersections by a continuous longitudinal strut. The two pairs of transverse struts nearest the crown are latticed together on their top and bottom flanges with 3 x 3-inch horizontal X-bracing angles, making virtually two compound struts, one on each side of the center hinge.

The roadway platform is uniform from abutment to abutment, and is supported in the planes of the arch ribs on two lines

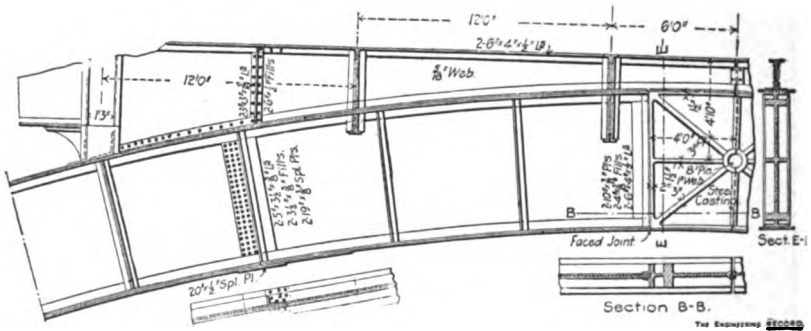

CROWN HINGE AND SPECIAL LONGITUDINAL GIRDERS.

of 24-foot longitudinal plate girders, 36 feet apart. These girders are riveted together through their end stiffening vertical flange angles to the webs of the vertical spandrel posts and viaduct posts, and are web-connected at their center points to the intermediate floorbeams, the alternate floorbeams being riveted directly to the tops of the vertical posts between the ends of the longitudinal girders. Over the center of the arch span five panels of the longitudinal girders are made special, the webs being cut to the intersecting curves of the arch ribs, and the lower flange angles bent to correspond and shop-riveted to the

top flanges of the ribs, thus making the girders integral with the crown sections of the ribs. Measuring from the crown, the third panels of these special girders are field-spliced in the middle so as not to project during shipment beyond the ends of the rib sections, and the shore ends with the short vertical columns attached were shipped separately and field riveted to the tops of the upper ends of the next sections of the ribs. Over the crown pin the ends of the longitudinal girders are spliced with web cover plates and bolts in slotted holes. The middle two floorbeams are 6 feet on each side of the crown pin, and are riveted through their vertical end web-stiffener and flange angles to the webs of both longitudinal girders and arch-rib girders.

The spandrel posts are pairs of 15-inch channels, latticed, and beveled at the foot to fit the top flange of the arch rib,

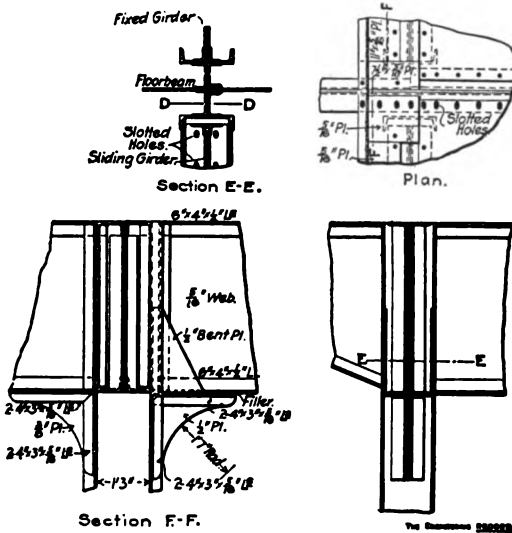

GIRDER AND COLUMN CONNECTION.

to which they are field-riveted through bent-plate flanges. The tops of the posts have no cap plates or flanges, and are flush with the top flanges of the longitudinal girders. The ends of the bottom flanges of the longitudinal girders are seated on and field-riveted to solid-web knee braces shop-riveted to the webs of the post channels. The four transverse bents of spandrel posts over the haunches are sway-braced by pairs of X-brace 4 x 3-inch angles latticed together.

The viaduct posts are pairs of 15-inch channels, latticed, with bottom flange angles on all sides, and 28 x 32-inch base plates. The bents are braced transversely by horizontal struts and X-braces, the former being rectangular in cross section and made of four 3 x 3-inch angles latticed on all four sides, and the latter of pairs of 4 x 3-inch angles, latticed. The struts and braces are field-riveted to vertical transverse plates, which are shop-riveted either in pairs to the webs of the post channels, or with flange angles to the batten plates on the post flanges.

The floorbeams are 48-inch plate girders 36 feet long, with their top and bottom flanges flush with those of the longitudinal girders to which they are coped. The web-connection field rivets which secure them to the longitudinal girders also engage the end web-stiffener vertical angles of 6½-foot cantilever sidewalk brackets on both sides of the roadway, as shown in the accompanying side elevation. There are six lines of roadway stringers, with web-angle and shelf connections to the floorbeams. Their top flanges are coped and are flush with those of the floorbeams, and receive the 5-16-inch buckle plates about 5½ feet wide which support the asphalt roadway pavement. The center four lines of stringers are in the planes of the 9-inch girder rails for the street cars. The buckle plates are riveted across the top flanges of the stringers with flattened-head rivets and between these 3 x 5-16-inch transverse filler plates are counter-sunk riveted to receive the bases of the rails and lift them clear of the flathead rivets.

From the curb to the outer rail the roadway surface is crowned 4 inches, and to provide for the different lines of the pavement without an unnecessary difference in the thickness, the buckle plates in the side panels are laid convex side down, while all others are reversed. The 12 x 12-inch concrete curbs are 36 feet apart in the clear, and their upper surfaces form part of the sidewalk. The outer ends of the sidewalk brackets are riveted to the continuous fascia girders, which project 9 inches above the top flanges of the former and are braced to them by solid-web kneebraces. The cast-iron sidewalk posts are slotted to seat on the top flanges of the fascia girders and have their outer faces extended down to bolt across the girder webs. In the webs of the floorbeams there are four holes 18 inches in diameter, faced with circular flange angles on both sides, which serve as saddles for the support of gas and water mains. Alternate floorbeams and brackets are riveted to longitudinal diaphragms in the tops of

the vertical spandrel and viaduct posts; these diaphragms also serve to make continuous connections between the longitudinal girders except at expansion points. In the middle of the arch span and over each of the tower bents the longitudinal girders

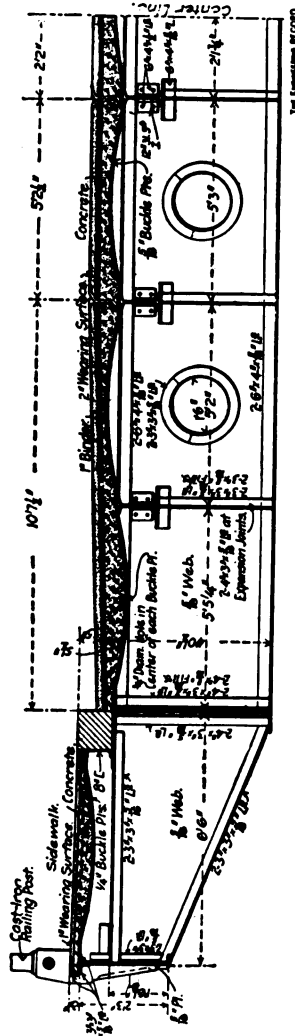

HALF CROSS-SECTION OF ROADWAY PLATFORM.

and stringers have sliding seats, and the buckle plates are bolted to the floor beams with slotted holes to allow for expansion and contraction. All the buckle plates are leveled up to sub-grade with 1 : 3 : 5 Portland cement concrete made with river gravel.

The curb and the wearing surface of the sidewalk are composed of 1 : 2 Portland cement mortar.

The end floorbeams, over the abutments, are 3 feet deep, with parallel top and bottom flanges made of pairs of 4 x 3-inch angles without cover plates. The 4-foot middle panel and the 5-foot end panels are made with 3 x 3-inch single angle X-bracing and no web plates. Two intermediate panels, on each side of the center, each about 5 feet long, are made with solid 5-16-inch web plates, with holes for the pipe mains, but have no circular flange angles riveted around them. These floorbeams are riveted to the longitudinal girders flush with the lower flanges of both and receive the roadway stringer bearings across their top flanges. They are more like end struts than regular floorbeams, and the lower flanges are supported from the abutment on cast-iron shoes under each stringer.

In all the expansion joints of the pavements the flat ends of the buckle plates slide on the top flanges of the floorbeams and carry on their upper side a riveted Z-shaped transverse curb,

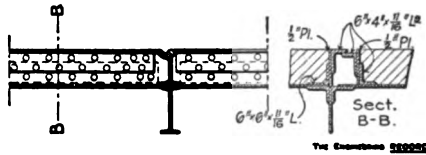

ROADWAY EXPANSION JOINTS.

which retains the paving and has a horizontal top flange engaging a flange angle riveted to the fixed curb on the floorbeam, thus making a close sliding joint like an apron with it.

The bridge contains about 1,517,000 pounds of steel, 1700 cubic yards of masonry, 1800 square yards of asphalt pavement, 5500 square feet of cement sidewalks and 900 lineal feet of cement curb, and cost \$86,000.

The semi-arch ribs have pin bearings at the crown and skew-backs, and, like the roadway platform and viaduct spans, were erected without falsework by overhead traveling derricks.

Erection was simultaneously commenced at both abutments by stiff-leg derricks, each having two 30-foot masts 36 feet apart connected by transverse X-bracing and a horizontal floor platform on transverse and longitudinal sills, with the feet of the stiff legs connected to the ends of the latter. There were two 35-foot 10-ton booms with steel wire rope topping lifts and hoisting tackle

operated by stationary hoisting engines on shore beyond the abutments. The derricks were skidded along on rails 36 feet apart in the planes of the arch ribs and viaduct columns, and when in use were anchored at the feet of the stiff legs to the fin-

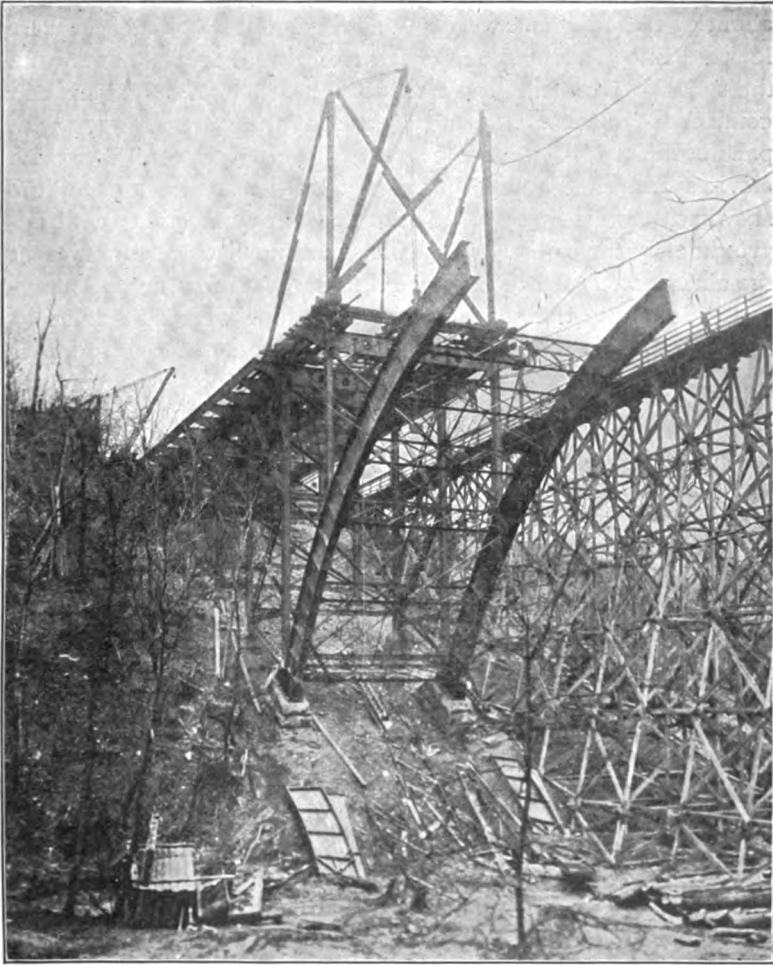

GUYED CANTILEVER ERECTION OF FERN HOLLOW BRIDGE,  
195-FOOT SPANS.

ished structure. They erected the columns and girders of the viaduct structure one panel in advance, and, moving forward on it towards each other, erected the arch ribs, spandrel posts and roadway platform for the center span, panel by panel, in the same way until they met at the crown of the arch.

The end sections of the arch ribs have half-hole bearings on the skewback pins, and are made with a clearance enabling them to rock through a small angle at that point. They were seated in the required positions without anchorage and supported by the main piers and by inclined timber shores, and the second sections, about 33 feet long and weighing about 17,000 pounds each, were lowered into place and supported from the derrick booms until the splices were made, the transverse bracing all bolted up and connections made at the upper ends of the lower flanges with pairs of inclined back-stays. These are 2 x 2-inch steel rods with clevises and sleeve-nut adjustments, and near the tops of the skewback towers had eyebar-head and pin connections with approximately horizontal rods which continued to anchorages at the abutments. Reactions were thus supplied for the overhanging ends of the ribs, and the third sections were assembled as the second had been; they also were supported at the extremities by similar pin-connected back-stay rods. Long U-plates were secured to the lower flanges of the ribs by  $1\frac{1}{2}$ -inch turned bolts, and, their wings engaging the edges of the flange cover plate and being parallel to the girder webs, received the clevises on the ends of the back-stays. In the second set of back-stays a double yoke and two sets of screw-end rods were inserted near the tops of the tower and were accessible from suspended working platforms so that the principal adjustments could be made there and the U-bolt pins moved until they were at the computed horizontal and vertical distances from the centers and tops of the skewback columns, which were plumbed and served as the bases of the triangles of location. The adjustment yokes were made as shown in the accompanying detail with two built beams which could slide freely on the connecting rods, which were overlapping lengths of the back-stays. Each pair of back-stay rods crossed one yoke and was attached to the opposite one, so that their tension tended to pull the yokes together. They were kept apart at first by blocks of timber, which were cut of such a length that the back-stays maintained the ends of the arch ribs somewhat above their required positions without using all the thread on their screw ends, and the yoke rods were screwed up tight against the blocks so that the yoke temporarily formed a link of fixed length in the anchorage device. When the crown sections of the arch ribs were put into place they were lowered from the derrick booms into approximate position between the ends of the incompletd semi-ribs with a clearance of 10 inches between their adjacent





## CHAPTER XVII.

### MIDI, MAHONING RIVER AND MAIN STREET (MINNEAPOLIS) BRIDGES. SPANS 205 TO 258 FEET.

The Pont du Midi is an important highway bridge  $767\frac{1}{2}$  feet long and 66 feet wide which crosses the Rhone at Lyons, France, and connects la Mouche and Perrache railroad depots. It has three 205-foot spans carrying a 36-foot roadway and two 15-foot sidewalks and was described in "The Engineering Record" of April 30, 1892, and in the "Génie Civil," Paris, of March 5, 1892. Each span has eight two-hinge plate girder arch ribs of 14.7 feet

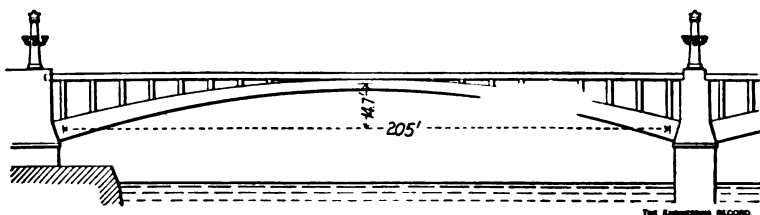

PONT DU MIDI, LYONS, FRANCE.

rise on centers and 21.5 feet clearance above water level. Each rib has a 7-16-inch web made of two plates, one above the other in the same vertical plane, spliced together with double cover plates and two T-shaped longitudinal reinforcements on the center line. The web is solid and continuous at the crown, and at the ends is reinforced with double cover plates on each side and with oblique ribs converging to the skewback pin and bolted between double radial flanges of the end casting, which has a semi-circular bearing on the flattened hinge pin, set on adjustment wedges in the cast pedestal. The 16 x 60-inch pedestal has three webs, is countersunk in the oblique surface of the pier masonry and has wedge bearings for the girder flanges.

A longitudinal girder 19 inches deep is seated on each rib at the crown and has four equi-distant spandrel posts riveted with oblique connection angles to the top flange on each side of the center. The arch ribs and spandrel posts have angle-iron sway-brace frames and the buckle plate floor is leveled with concrete and

paved with wood blocks. There is a lateral system of X-brace channels in the plane of the lower flanges of the ribs. There is a heavy ornamental cast-iron cornice and parapet and there are

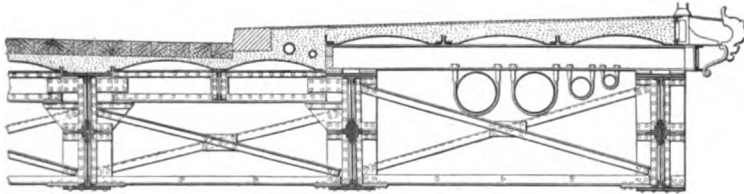

Half Cross-Section at Crown.

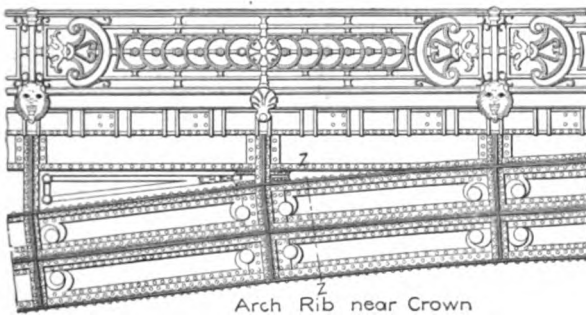

Arch Rib near Crown

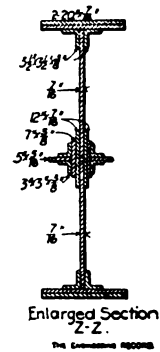

Enlarged Section Z-Z.

sculptured figures in deep relief between the skewbacks on the pier faces. The spandrel posts are covered with ornamental cast-iron pilasters in the planes of the outside ribs, and there are tall and

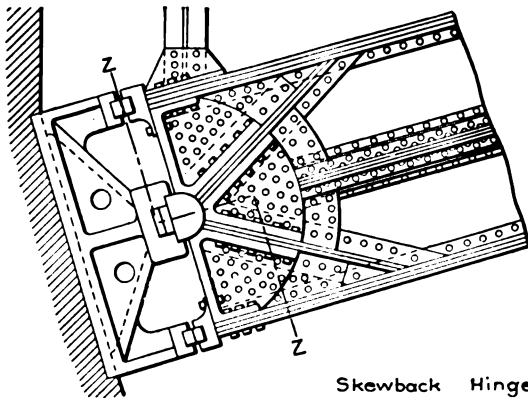

Skewback Hinge

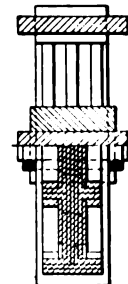

Section Z-Z

massive lamp posts at the ends of the spans. The bridge cost about \$380,000, and each span was erected in two successive longitudinal halves by gantries spanning four ribs and carrying mov-

able hand windlasses. The trussed falsework conformed to the curve of the lower flange of the arch rib and was supported on one pile bent tower in the center and one at each end of each span. Each rib was assembled on four jackscrews, two near the crown and one near each haunch.

South Market Street, Youngstown, Ohio, crosses the Mahoning River with an arch span having two segmental plate girder two-hinged ribs, 210:58 feet long between centers, 60 feet rise and 122.38 feet radius, as described in "The Engineering Record" of Feb. 4, 1899. The ribs are 28 feet apart, are divided into 16 nearly equal panels by horizontal cross struts, and are braced by pairs of angle diagonals each running across two panels. Vertical columns at the skewback and at six intermediate points carry

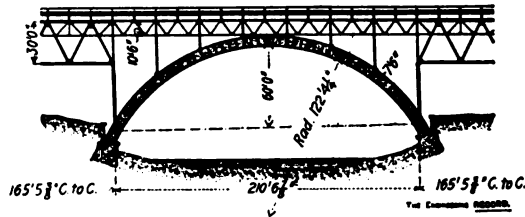

MAHONING RIVER BRIDGE, YOUNGSTOWN, OHIO.

two triangular riveted longitudinal roadway trusses in the planes of the arches, and these roadway trusses are, by means of some false members, combined with essential members, apparently extended through the tops of the triangular trusses of the 165.45-foot side spans. The river ends of the 165-foot spans are supported on rocker bents 25 feet high that engage the main skewback pins, and besides these expansion adjustments five intermediate roller bearings are provided at different places in the approach viaduct, and one at each abutment. The tower piers are of concrete with sandstone caps, and the abutments and skewback masonry are of sandstone, all carried down to the solid rock.

The material of the superstructure throughout is medium basic open hearth steel, except for the wrought iron diagonal rods, and is proportioned in accordance with Thacher's highway bridge specifications of 1894, providing on the viaduct for a live load of 80 pounds per square foot on the sidewalks and 90 pounds per square foot on the roadway, or a 15-ton roller with 10-foot base or a 20-ton traction engine with a 12-foot base. On the arch the dead load was assumed at 6200, and the live load taken at 4720

pounds per linear foot, giving the following results: moments: dead load, 972,000 foot-pounds; live load, 2,054,000 foot-pounds; temperature, 368,000 foot-pounds; total, 3,394,000 foot-pounds. Thrusts, dead load, 335,200 pounds; live load, 178,000 pounds; temperature, 7700; total, 520,900. Total maximum shear, 115,400 pounds. The unit stresses permitted were in tension, 10,500 [ + (  $m \div M$  ) ] for built members, 18,000 for lateral angles, 20,000 for lateral rods. In compression 13,750 — 577 (  $1 \div r$  ) for two flat ends; 13,750 — 642 (  $1 \div r$  ) for one flat and one pin end; 13,750 — 707 (  $1 \div r$  ) for two pin ends,  $\frac{11,700}{1 + 0.288 (L^2 + b^2)}$

for top flange riveted beams;  $\left[ \frac{12,500}{1 + 0.288 (L^2 + b^2)} \right]$  for top flange rolled beams.

In the above formulas  $m$  = minimum stress,  $M$  = maximum stress,  $1$  = length in feet from center to center of connections,  $r$  = least radius of gyration of member in inches,  $L$  = unsupported length of flange in feet, and  $b$  = width of flange in inches. Eleven thousand and 19,000 pounds per square inch were allowed throughout for shearing and bearing strains respectively. The arch ribs were each made with one 90 x  $\frac{1}{2}$ -inch web plate, two 6 x 6 x  $\frac{3}{4}$ -inch angles, and three 16 x 11-16-inch cover plates in each flange. The floor beams were 54 feet in total length, having a 13-foot cantilever projection beyond each truss. Their calculated flange strain was 89,500 pounds, and they were constructed with 32 x 5-16-inch webs and 5 x 3 $\frac{1}{2}$  x  $\frac{1}{2}$ -inch chord angles. Horizontal lateral braces cross two panels of the floor beams throughout, and are composed of single and double-pin connected rods from 1 inch round to 1 $\frac{1}{4}$  inches square.

The bridge was erected from one end by an overhead traveler, which ran on top of the completed viaduct, and assembled it panel by panel in advance. This traveler consisted essentially of a transverse framed bent of 12 x 12-inch timbers, 28 feet wide and 30 feet high, with a 30-foot boom on each side. The vertical bent was set on the forward end of a timber frame 40 feet long, to which it was stayed by diagonal side planks spiked on and by steel rods guying it from the top of the mast to the rear of the frame. These rods had sleeve nut adjustments and were pin-connected to iron gusset plates, which were bolted to the timber. Each boom was fitted with a five-part manila tackle for topping and another for hoisting, and had a capacity of 20,000 pounds. The traveler was skidded along on the floor stringers of the



completed viaduct, and had a sufficient overhang to assemble the work 30 feet in advance, material farther out being handled with a gallows frame. Falsework was built under the side spans next the arch, and the traveler was moved progressively over them to the river span, which was supported on framed falsework about 75 feet high.

The spandrel work and roadway system were carried on as the arch rib sections were set from one end to the other, the traveler continuing on top of the roadway from which it handled the material at the main span. The arch ribs were set on cribwork blocking on top of the falsework caps, with pairs of oak adjustment wedges, which were slacked off about 2 inches in the center to swing the span. The segments of the arch ribs were received from the shops in straight sections about 30 feet long, weighing 20,000 pounds each, maximum. They were hand-riveted in the field, with web and flange-plate splices, all joints being reamed in place with an air reamer. The last connection was made at the joint nearest the second skewback. All material was delivered on top of the bank at one end of the bridge, and taken to the traveler by trucks running on a low trestle alongside the viaduct, and was received by the main booms, swinging to the side through an arc of 90 degrees. Material was handled by one four-drum hoisting engine.

The skewback connections are shown partly in center cross-section to give interior construction. The end section of the arch rib is built up of four 6 x 6-inch curved angles and a  $\frac{1}{2}$ -inch web plate, reinforced with two web plates, one pin plate and three radial 5 x  $3\frac{1}{2}$ -inch stiffener angles on each side. Each chord has three 16-inch flange reinforcement plates, and has the lines of the parallel flanges continued to the pedestal by web-plate gusset brackets between the beveled end and the pedestal.

The pedestal has a  $\frac{3}{4}$ -inch planed base plate  $7\frac{1}{2}$  feet long by 3 feet  $3\frac{1}{2}$  inches wide, to which three vertical ribs are connected by two 6 x 6-inch angles each. The middle web is double, and it and the side webs are reinforced by pairs of 5 x  $3\frac{1}{2}$ -inch and  $3\frac{1}{2}$  x  $3\frac{1}{2}$ -inch radial angles, and by pin plates, and are connected by vertical transverse diaphragms in the plane of the axis of the skewback pin. The planed base plate of the grillage shoe is  $72 \times \frac{7}{8} \times 90$  inches, and its 18-inch I-beams weigh 55 pounds per foot, and are connected by three transverse lines of vertical diaphragms and by transverse end beams mitred into the

flanges of the side beams and web-riveted to the ends of the intermediate beams, as shown in plan.

The Main Street highway bridge across the Mississippi River, Minneapolis, was a two-span suspension structure which became inadequate for the traffic, and was first widened by the construction of a 40-foot roadway alongside carried on steel arches. Afterwards the suspension bridge was replaced by similar steel arches. Each span of the first structure has three three-hinged plate girder ribs 15 feet apart, with a length and rise of 258 feet and 26 feet

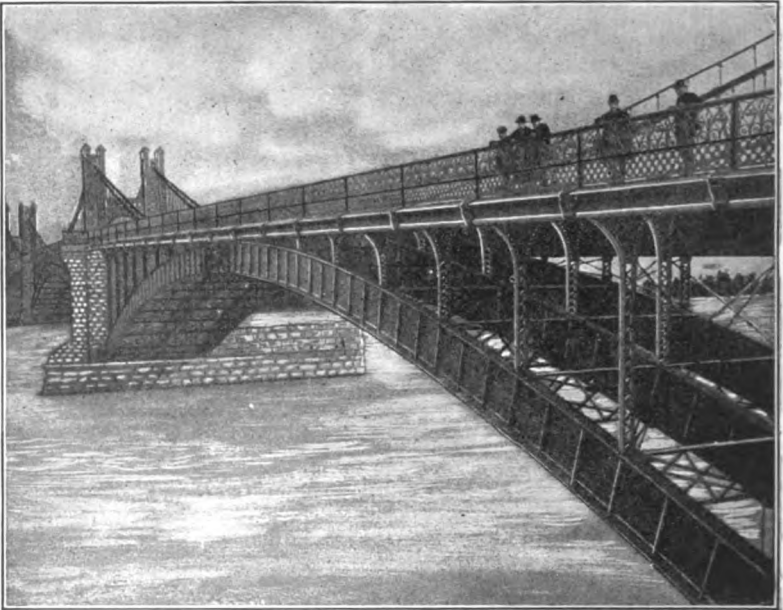

CITY BRIDGE ACROSS THE MISSISSIPPI RIVER AT MINNEAPOLIS.  
SPAN 258 FEET.

respectively on centers. Vertical spandrel posts about 13 feet apart are seated on the top flanges of the arch ribs and carry the floor, which has a 12-foot sidewalk cantilevered about 3 feet beyond the outside rib. At the feet of the spandrel posts the arch ribs are braced together by lattice girder sway-brace frames field-riveted to the radial web-stiffener angles, and every panel between sway braces is X-braced in the planes of the top and bottom flanges with sleeve-nut rods which have jaw ends pin-connected to the splice plates of the top and bottom flanges. The spandrel posts are also sway braced by pin-connected sleeve-nut rods between the floor-beams and rib frames. Each semi-arch rib is made in ten

sections about  $13\frac{1}{2}$  feet long, spliced together with web and flange cover plates shop-riveted to one section to make jaws which are field-riveted to the adjacent section. The ribs have straight parallel flanges and have a uniform depth of 5 feet except the

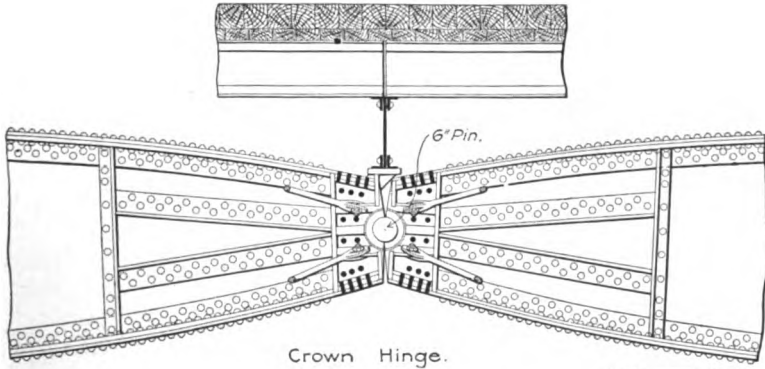

sections nearest the crown and skewbacks, which are tapered so that the flanges converge towards the center of the 6-inch hinge pins. The crown and skewback sections of the girder arch rib

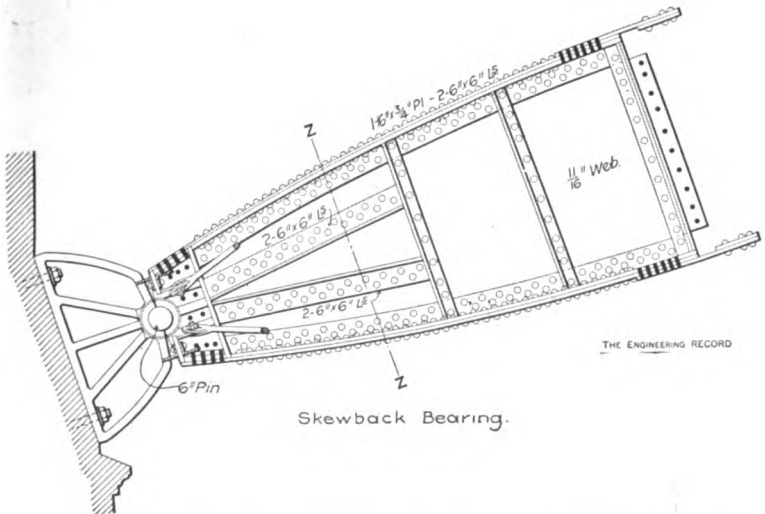

are alike and their webs are engaged between the double webs of steel bearing castings, to which they are secured by 1-inch turned taper bolts. The castings have horizontal semi-cylindrical bearings about 15 inches long with stiffening flanges for the hinge pins.



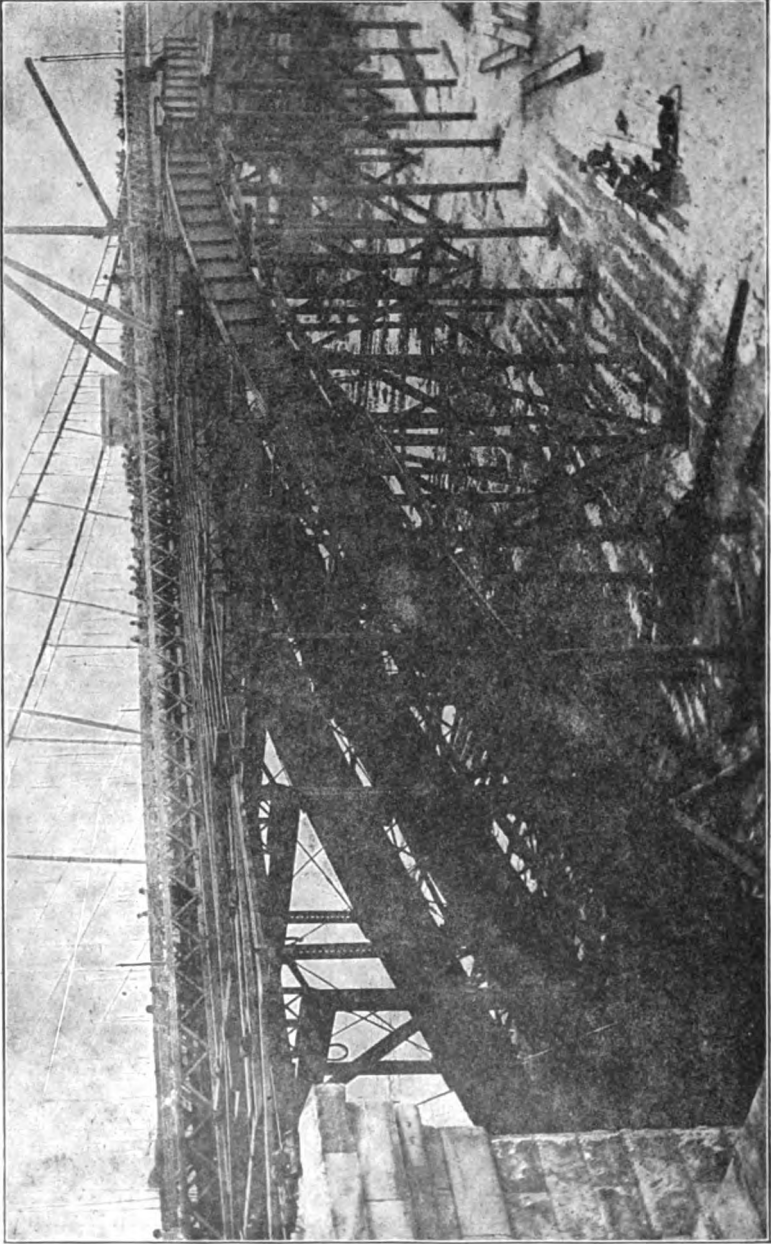

ERECTOR OF MAIN STREET BRIDGE. FALSEWORK SET THROUGH ICE.

At the skewbacks the pins are seated in cast-iron pedestals with 4 x 5-foot bases. All the steel castings have longitudinal flanges to receive the lateral pins and are made with V-shaped clearances above and below the pins. The crown castings are made alike except that only one of each pair has a horizontal shelf to carry the plate-girder floor-beam, which also serves as a lateral strut. The skewback castings have transverse webs to which the end

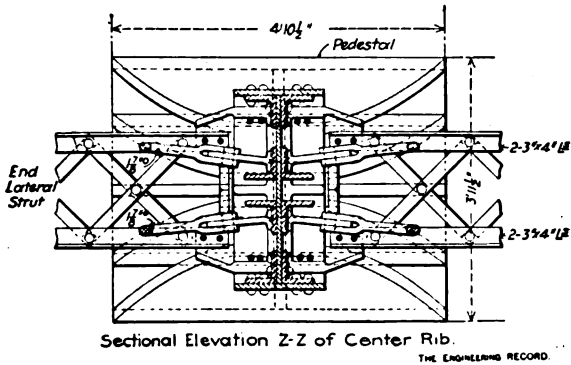

sway-brace frames are bolted, as shown in the detail. The three ribs were proportioned for different loadings; the maximum was 1400 pounds dead and 1800 pounds live load per linear foot, and the corresponding cross-sections of the crown and skewback sections were 163 and 85 square inches. The weight of the span was about 1,500,000 pounds, and it cost about \$77,000. It was described in "The Engineering Record" of May 10, 1890.

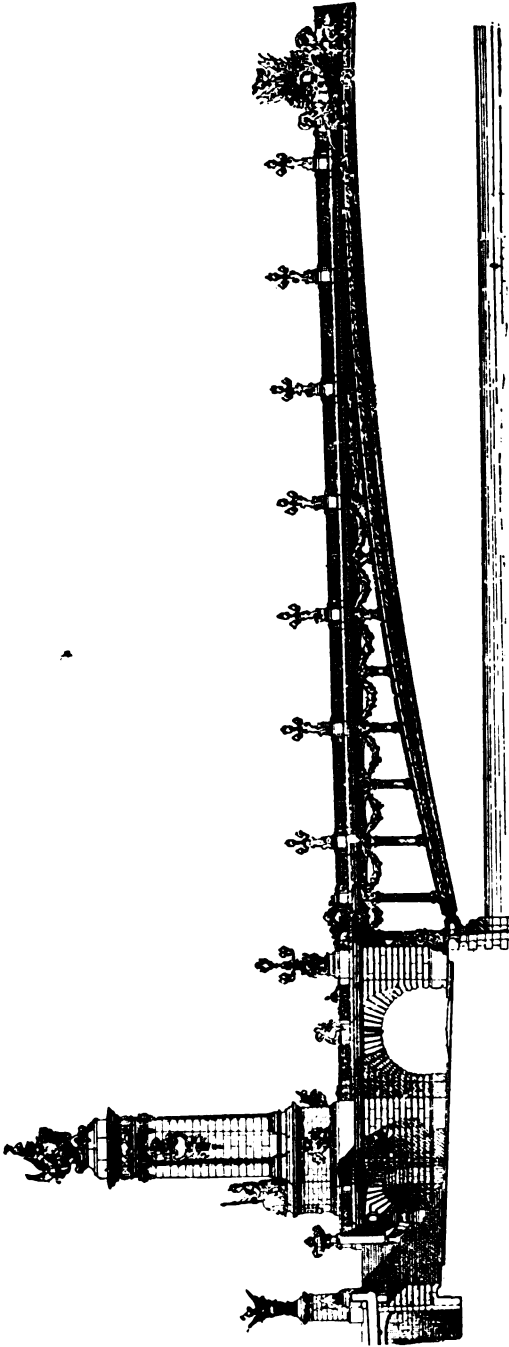

PORTAL TOWER, APPROACH MASONRY AND DECORATED ARCH RIB OF ALEXANDER III. BRIDGE.

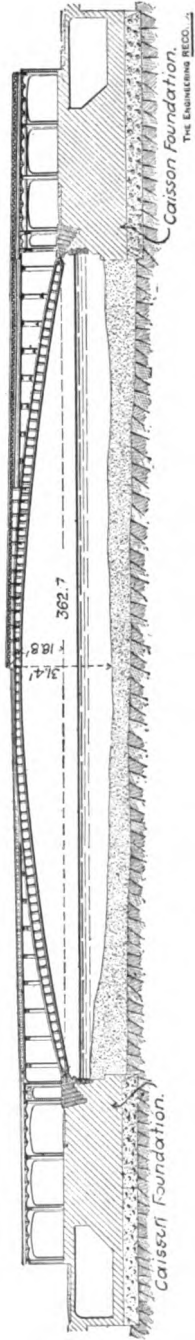

THE ALEXANDER III. BRIDGE, PARIS.

## CHAPTER XVIII.

### **ALEXANDER III. AND WASHINGTON BRIDGES. SPANS 362.7 AND 510 FEET.**

The Alexander III. highway bridge across the Seine, at the exposition grounds, Paris, is the largest and most important cast-steel arch span in the world. It is interesting on account of its magnitude, for the very flat curve of the arch, for the adjustments of the crown segments, for the great amount of ornamental work and the architectural beauty of the structure, for the methods of manufacture of the cast-steel segments and for the very elaborate and unusual method of erection. The bridge is skewed 6 degrees and 22 minutes and has a width of 131 feet. It carries the full width of the street and sidewalks without obstructing the vista, and, having the standard pavement and heavy parapets with ornamental lamp posts at every panel, appears from the street like a special promenade rather than a bridge. The 67-foot roadway has a 2 per cent. grade to the center, about 32 feet above water level, and is slightly crowned transversely; the two 32-foot sidewalks are pitched sharply to the center gutters.

Each end is flanked by a pair of masonry towers rising about 75 feet above the pavement and ornamented with sculpture and statuary. The roadway is carried across the wide, low abutment piers on plate girder approaches, enclosed in ornamental masonry with curtain walls in which there are archways for the low-level intersecting streets and passages. The embankments are retained by long and handsome wing walls parallel with the river on the shore edges of terraces, from which there are entrance stairways to the ends of the span. The skewbacks are about at lower street grade and the face walls of the abutments above them are pierced with ornamental arches of about 9 feet span. The faces of the arch ribs and the roadway platform are masked with cast-iron plates enriched with mouldings, sculpture and elaborate ornamentation.

The rise of the arch is only about 1-17 of the span, so that the thrust developed causes a maximum reaction of about 850 tons, making a very small angle with the horizontal at each skewback

pedestal. To resist this the concrete and masonry abutment piers were built on the largest (110 x 144-foot) steel pneumatic caissons ever made. They were assembled in position on the river banks with their outer edges supported on piles, and were sunk to a

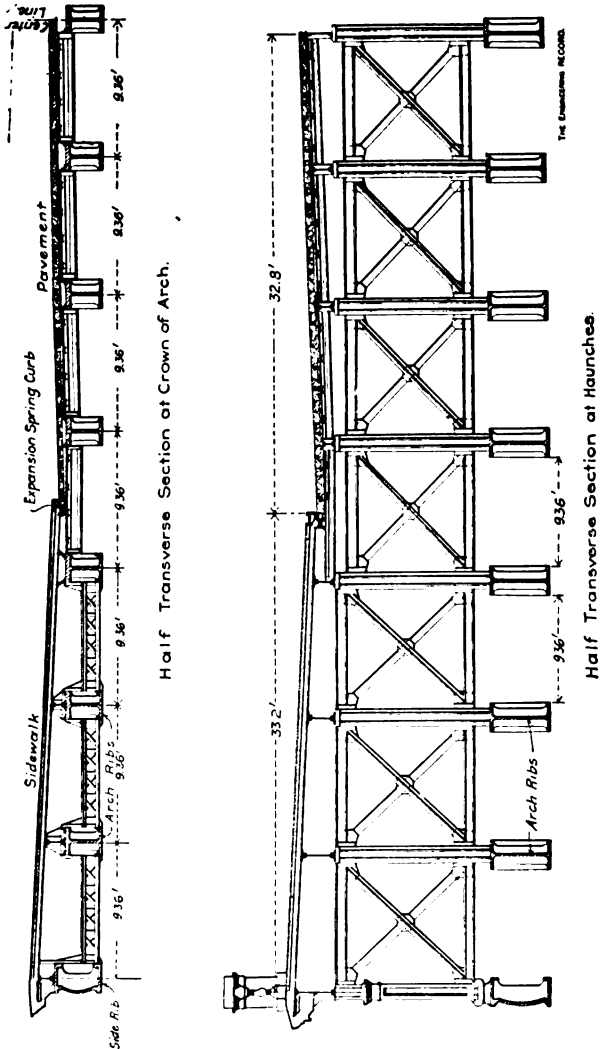

sandy stratum about 26 feet below ordinary water level. They were filled with concrete having transverse grooves in the upper surface to bond with the upper part of the piers and afford resistance to the horizontal thrust.

There are fifteen cast-steel plate girder ribs, 5.56 feet apart on centers, which are segments of a circle of 802 feet radius. Each rib is a three-hinge arch of 353 feet span, and  $20\frac{1}{2}$  feet rise of intrados. The skewback pins are set in pedestals which project from the face of the abutments so as to increase the span to 358 feet. Each rib has a minimum depth of about 34 inches at the crown and a maximum depth of about 60 inches at the haunches and is cast in 32 segments of an average length of about 12 feet and a weight of from three to four tons. The outside ribs have a channel-shaped cross-section with the web convex outwards. The other ribs have I-shaped cross-sections; all the webs are vertical and each section has, on both sides and both ends, a flange about 2 feet wide, which is strengthened by transverse webs. All metal is 2 inches or more in thickness. The hinge pins are about 8 inches in diameter, and have semi-cylindrical bearings in the crown and end segments, which have tapered flanges converging towards their centers and are reinforced by center ribs.

The faces of the radial flanges at the ends of the arch segments were countersunk so as to have bearings only on the webs and around the edges, and they were drilled for twelve  $1\frac{1}{4}$ -inch connection bolts. Inclined seats were cast on the top flanges and had four holes drilled in each to receive the connection bolts

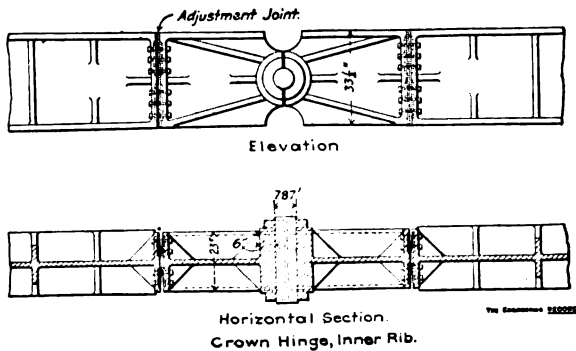

through the bases of the vertical spandrel posts. The seats on the top flanges of the pedestals are horizontal and have spherical sockets without bolt holes to receive the convex centers of the end post bases. All the segment joints have full bearings, except those between the crown segments and the adjacent ones, which have bearing only in the plane of the web and have the end flanges beveled on both sides of the center vertical lines so as to give hori-

zontal clearances of about 0.6 inch for transverse movement of the crown pins.

The pedestal for the outer ribs are in two pieces, bolted together through longitudinal vertical webs. All have horizontal and nearly vertical masonry seats on the lower edge and base respectively, and carry the skewback pins out nearly 3 feet clear of the abutment copings. The arch ribs have no direct lateral or sway bracing except for the center half of the span, where the floor system is connected to them. Over the haunches the spandrel posts have a transverse web and four flange angles with their flanges

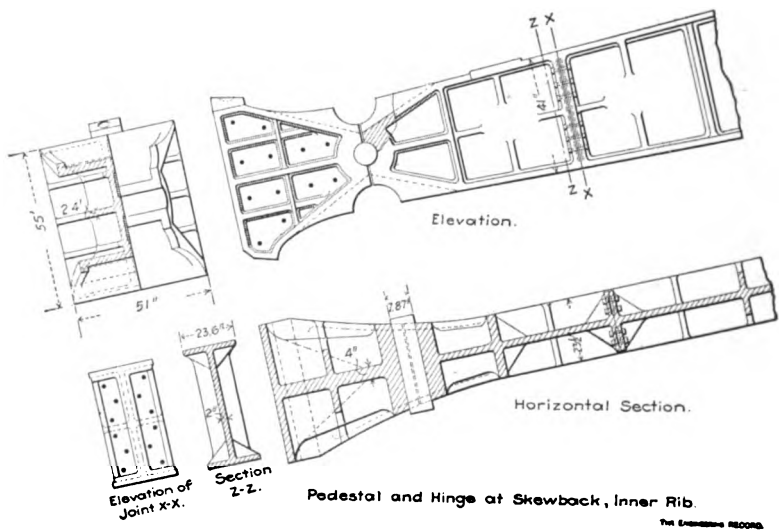

turned in, except on the outer ribs, where they are of cast-iron with moulded faces. The spandrel posts have top and bottom horizontal transverse struts made with pairs of channels latticed, between which there are X-braces made of pairs of angles riveted together back to back and having their flanges turned in opposite directions to clear at intersections.

The roadway pavement is laid on flat steel plates, stiffened with channel bars riveted to the under side, supported on transverse plate girder floor-beams  $5\frac{1}{2}$  feet long, web-connected to longitudinal girders supported by vertical spandrel posts seated on top flanges of the arch ribs, about 12 feet apart, from the haunches to the skewbacks. In the center of the span the lower edges of the girders are beveled to fit the top flanges of the ribs on which they are seated.

The bridge is proportioned for a dead load of 332,859 pounds for each semi-arch rib, and for a live load of 82 pounds per square foot. The arch ribs have been proportioned for maximum tension stresses of 12,800 pounds and 14,200 pounds per square inch, for dead and live loads, respectively. The maximum compression in the top flanges under ordinary loads is 13,640 pounds, and for dead load only is 9280 pounds per square inch. Under the most unfavorable loads the maximum stresses are 22,670 pounds and 21,230 pounds, and in the bottom and top flanges, respectively,

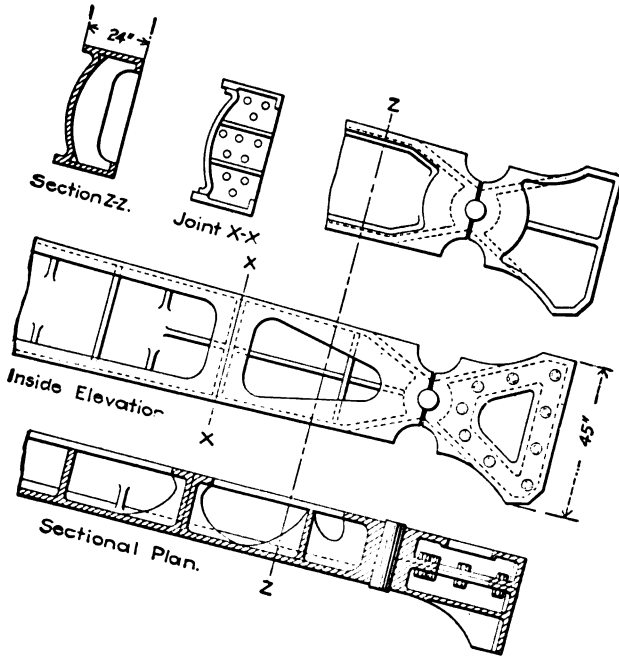

End Sections and Skewback for Outside Arch Rib.

THE ENGINEERING RECORD

of the thirteenth segment from the skewback, and under the most favorable conditions the corresponding minimum stresses are 2582 pounds and 4000 pounds. For a temperature variation of 26 degrees Centigrade, the arch thrust is increased or diminished about 2.2 per cent. and the crown rises or falls 0.2 inch for each degree. Under full live load the skewback pressures are 2,004,060 pounds for each pedestal, which gives pressures of 7850 pounds per square inch on the pin, and 98,300 pounds and 25,600 pounds per square foot on the granite seats and on the pier masonry, respectively. The deflection at the crown under dead load is  $5\frac{1}{2}$



inches and under full live load is 8.1 inches. Tension tests of the steel in the arch ribs showed a maximum elastic limit and ultimate strength per square inch of about 51,000 and 93,000 pounds, respectively.

The contracts for casting the arches were awarded to five different firms, each of whom made from two to five ribs, all performing the work by different methods, under the same general supervision. Full-size drawings of each segment were furnished to each shop and wooden patterns were made of each segment in the intermediate semi-arch ribs, and of all the segments in the outside arch ribs. They were moulded with the webs horizontal and the cores were made of coke with a coating of sand and an iron skeleton. The moulds were baked for 36 hours at a temperature of about 300 degrees Centigrade, and were surfaced with clay and graphite. The moulds were inclined somewhat from the horizontal when poured and various devices were resorted to to secure free shrinkage, for which 1.8 per cent. was allowed, and to avoid cracks.

In one shop the metal was poured fast at first and then slowly. In another shop the flasks were loosened in 15 minutes after they were poured. In the other shops the castings remained in the moulds from one to five days. In one shop the castings were annealed by heating to 1000 degrees Centigrade in 30 hours, maintaining that temperature for 6 hours and then cooling them for 62 hours. In another shop the heating was about the same, but the cooling to 600 degrees was made in 12 hours in a hermetically sealed furnace and from 600 degrees to normal in 12 hours in an open furnace. In another shop the temperature was raised to 900 degrees in 40 hours and then suddenly lowered to 600 degrees by opening the furnace. The furnace was then sealed and the casting allowed to cool gradually for about 45 hours. At another works after a preliminary annealing the temperature was raised in 12 hours to 1000 degrees and maintained there for 2 hours, then quickly reduced to 700 degrees, the furnace sealed and cooling slowly continued for 12 or 14 hours.

The castings were roughly dressed after annealing, marked by templates and gauges, the bearing surfaces planed and sometimes ground and then they were assembled on special platforms and the splice bolt holes accurately bored. As it required about two months to replace a segment, and as the erection had to be done as rapidly as possible, special precautions were taken at the shops to have the pieces perfect and the joints accurately fitted so

as to avoid danger of delay in the field. In one of the shops the segments were assembled on a concrete floor covered with iron plates, on which the outlines of the semi-arch were accurately marked. At another shop a heavy timber deck was built with iron plates at connection points and iron channels set in its surface at the lines of the neutral axis of its chord and of the top and bottom flanges, and on them the diagram of the rib was marked. At another shop the segments were supported at the joints on marble pedestals shimmed up level on planed rails, thus raising the segments so that the under sides of the outside ribs were accessible.

In erection the arch ribs were assembled in pairs on a curved platform suspended from a movable falsework bridge in the center of the channel and supported on towers and trestle bents at the sides. The movable falsework bridge had two lattice girder steel trusses 364 feet long, 24.6 feet deep and 18.7 feet apart on centers, which projected about 21 feet beyond each end of the arch span and were supported on steel towers about 25 feet high which rolled on transverse tracks on the river banks. The bridge was erected on shore in short sections which were successively connected and launched across the channel by protrusion, with a 50-foot pilot. The falsework trusses were intermediately supported at two points 174 feet apart, by pile piers in the middle of the channel.

The bridge carried between the trusses two trolley tracks, 9.36 feet apart. On each track two trolleys traveled from end to end of the trusses and received the arch segments from transverse surface tracks on the banks and delivered them to the required position on the falsework platform. The trolleys were traversed by endless chains, which, with their hoisting tackles, were operated by steam engines seated on cantilever platforms at the ends of the trusses. After erecting two arch ribs the movable bridge was moved 18.7 feet and erected the next pair of ribs, and so on. The arch segments were lifted by two pairs of hook-bolt clamps engaging the top flanges. The clamps were attached to the ends of a yoke, about 4 feet long, which had a pivoted connection to the hoisting tackle. This connection was movable along the yoke and its position was adjusted by a screw rod and ratchet, by which it could be varied to secure the exact inclination required for the different segments.

One day was required to place the four skewback pedestals and two days to assemble the remaining segments of one pair of ribs. The radial segment joints were very carefully cleaned and greased, and the segments were tilted by the screw adjustment on

the suspension yoke until they were exactly parallel to their required position and gradually lowered to place with the shore end sliding smoothly down in contact with the end of the last segment placed. When the flange holes matched two drift pins were inserted, the splice bolts put in place and pairs of camber wedges driven gently under the bottom flange near the ends of the segment. After all the segments were assembled and aligned the end segments were blocked away from the pier masonry so as to relieve the skewback pedestals of nearly all pressure, and the joint between the bases of the pedestals and the granite seats were grouted. Measurements were made, temperature noted and the corrections were calculated for the open joints between the key segments and the adjacent ones and steel wedges, previously prepared, were combined to correspond within about 1-50 inch, and were driven to adjust the crown segments. Notwithstanding every care it was generally found that the bearings for the center pin diverged about 1-100 inch, and this was rectified by grinding the face of one of the adjustment wedges.

After the bearings were satisfactorily adjusted, the arch ribs were temporarily braced by horizontal transverse struts, and pairs of screw rods at the segment joints with horizontal and vertical X-bracing of wooden struts in the panels thus formed. Twenty-four 16-to-1 jack screws with 4-inch stroke were put under the joints of each arch rib so that each would support the ends of two segments. Twenty of these screws, those over the suspended platform, were dynamometers, made by placing the screws in sleeves which engaged cylinders and took bearing on carefully rated spiral springs. The outsides of the sliding sleeves were graduated so as to indicate the amount of compression on the springs at any position. The jacks were screwed up to a pressure of 5 or 6 tons each at the crown and 7 or 8 tons at the haunches so as to receive as nearly as possible the calculated weight of the segments they supported and to prevent the development of arch stresses. The camber wedges were thus released and removed. All the jack-screws were uniformly operated to raise the arch slightly and the crown and skewback wedges were adjusted. Finally the jacks were slacked off in groups, the first being slacked from 5 to 4 tons, the second from 5 to 3 tons; then the first from 4 to 2 tons, the second from 3 tons to 1 ton, and so on, the whole operation taking only about two hours. Twenty working days were required for the actual erection of one pair of arch ribs, but several days more were really occupied by holidays and delays.

The foundations, superstructure and erection were described in "The Engineering Record" of February 26, 1898; September 4, 1897, and March 11, 1899. They were also fully illustrated in several foreign journals, including the "Annales de la Construction," of July, October and November, 1899; the "Génie Civil," of June 26, 1897, and February 4, July 8 and 15, 1898; the "Revue Industrielle," of July 9, 1898, and "Engineering," of August 20, 1897.

The Washington Bridge carries 181st Street, New York, across the Harlem River on two two-hinge plate girder arch spans about  $133\frac{1}{2}$  feet high in the clear, above mean high water. The bridge is notable for its handsome and massive design, the symmetry of outline, and especially for the dimensions of the arch spans, which are the largest of their kind yet constructed. It is also interesting as one of the first long-span steel plate girder arches, and for the excellent character of the details and workmanship, which are typical of advanced practice and modern methods. The design is an admirable combination of masonry and steel, which gives mass, beauty and dignity to a monumental structure and still preserves efficiency in a measure seldom found in large American bridges. Nineteen competitive designs were submitted by eminent American bridge engineers and contractors, and two prizes were awarded to them, although none of them met all the requirements or were adopted. They included two designs with 800-foot suspension spans; four designs with cantilevers of spans up to 560 feet; three designs with steel arches; three designs with steel arch trusses of spans up to 545 feet, and three designs with stone and concrete arches with spans up to 280 feet. A design having three 198-foot full-centered masonry arch spans over the river and a series of smaller shore spans on slender piers was considered the most meritorious, but was not accepted because it failed to meet the requirement that the main span should be of metal.

Another plan was subsequently submitted for a bridge with two 508-foot plate girder arch spans, heavy masonry piers and solid masonry wall approaches. This was modified to have 510-foot spans and masonry arch approaches, and the contract was awarded for \$2,055,000, for a structure having a total length of 2373 feet, which carries a 50-foot carriage way and two 15-foot sidewalks at a grade of 1:33. The three main piers are founded on solid rock, the center one being sunk in the river channel by the pneumatic caisson process to a depth of about 41 feet below

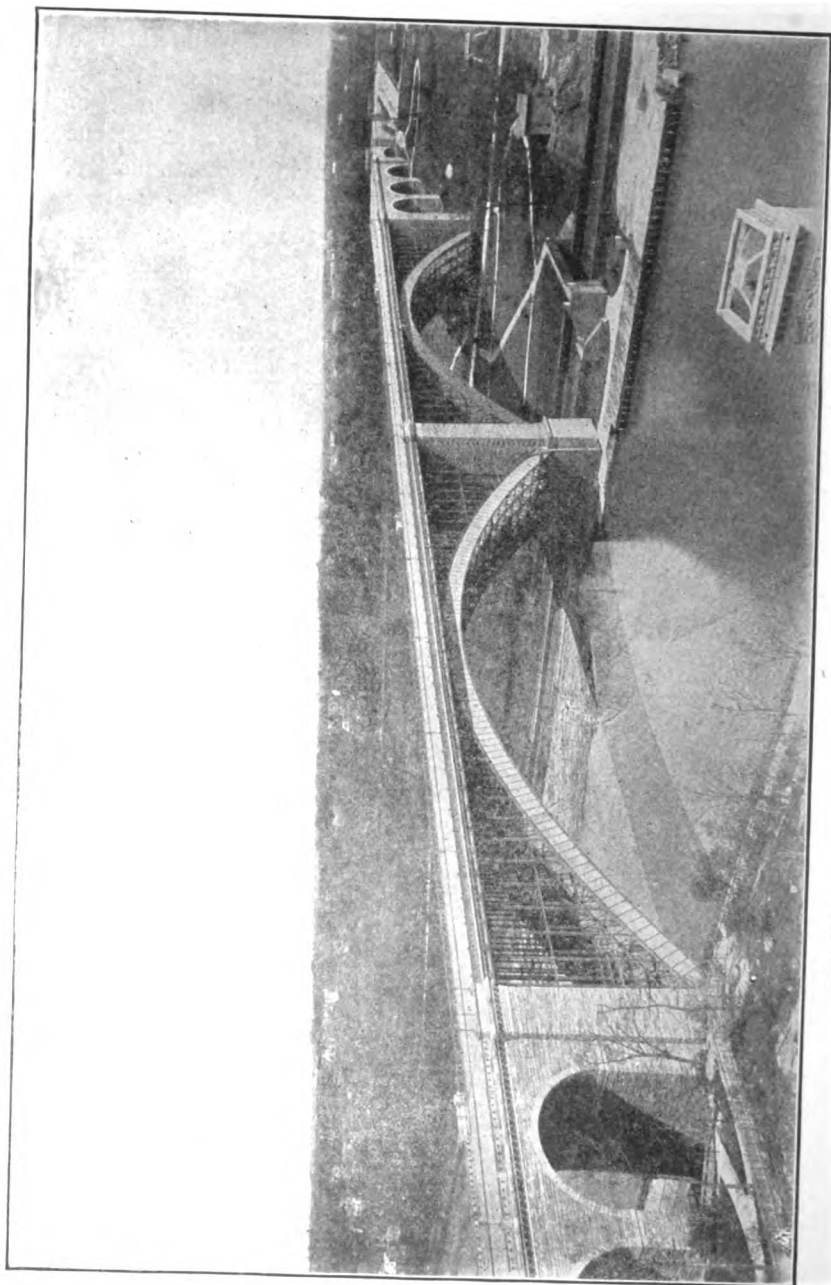

WASHINGTON BRIDGE ACROSS THE HARLEM, 610-FOOT SPANS.

mean high water. The end piers and the abutments have arched interior chambers enclosed with face walls 8 feet thick at the base. Each approach has three full-centered 60-foot arches and there is one 56-foot flat elliptical arch over the roadway. The ends of the piers, cornices and parapets are granite; the side faces of the piers, spandrel and abutment walls are of light gray gneiss, and the face masonry is backed with concrete.

The bridge is proportioned for a dead load of 225 pounds per square foot and a distributed live load of 100 pounds per square foot or a 20-ton road roller. The steel arches are proportioned for an assumed dead load of 15,000 pounds per linear foot of arch, and 18,000 pounds per linear foot of floor system and paving, for a live load of 8000 and a wind load of 1200 pounds per linear foot. Allowance was made in all parts of the structure for a variation of 75 degrees Fahrenheit in the tem-

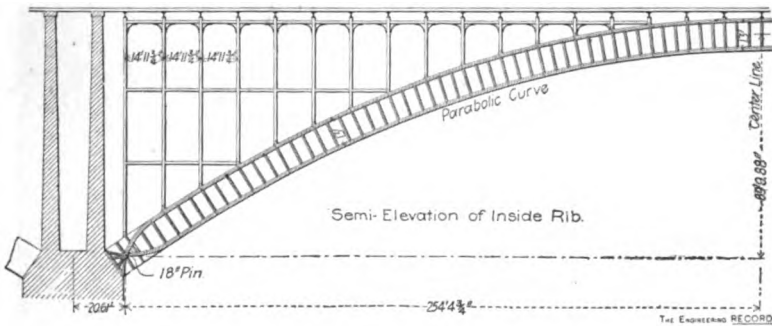

perature. The arch rib flanges were proportioned for maximum stresses of 15,000 pounds per square inch of gross section in compression, and for 18,000 pounds per square inch net of section in tension. The arch ribs are made principally of open-hearth steel with an ultimate tensile strength of from 62,000 to 70,000 pounds, and an elastic limit of 32,000 pounds per square inch. The computed rise of the crown due to maximum temperature variation is about  $2\frac{1}{2}$  inches. The computed maximum deflections are 2.3 inches vertical and 1.3 inches horizontal.

Each main span has six two-hinge plate girder arch ribs of 510 feet clear span, and about 91.8 feet clear rise on centers of skewback pins. The ribs are spaced 14 feet apart on centers and are braced by horizontal transverse struts at the panel points of the top and bottom flanges. There are pin-connected sway-brace rods in the transverse planes through the struts, and single

zig-zag lateral angles in each panel of the struts and arch ribs in the planes of the top and bottom flanges. Each rib is divided into thirty-four horizontal panels of 14 feet 11 $\frac{3}{4}$  inches. At each panel point there is a floorbeam supported on the caps of six vertical spandrel posts, each of which has an oblique base plate riveted to the top flange of one of the arch ribs. The spandrel

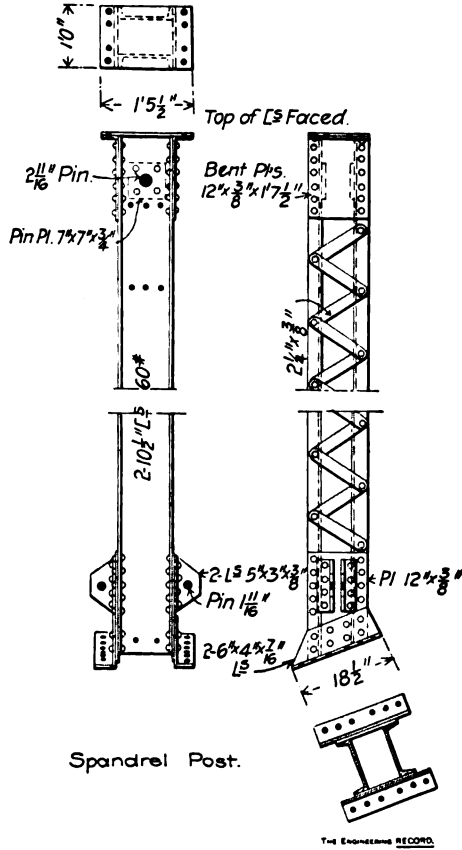

posts are braced by longitudinal and transverse horizontal struts, and have pin-connected sleeve-nut diagonal sway-brace rods. There are no spandrel posts at the seven panel points at the crown of the arch, and the floorbeams there are seated on short pedestals riveted to the arch ribs.

Each arch rib has a uniform depth of 13 feet, and is made in thirty-four nearly equal segments, with lengths varying slightly to give equal horizontal projections. The segments have

straight sides, and their center lines are chords and their ends are parts of radii of a parabolic curve.

The web plates are  $\frac{3}{4}$  inch thick in the end segments and  $\frac{5}{16}$  inch thick elsewhere. The flanges are double with an H-shaped cross-section composed of six 6 x 6-inch angles and 12-inch and 20-inch cover plates, with varying thicknesses, which have a maximum of 3 1-16 inches for the 20-inch plates. Each segment is divided into three equal subpanels by pairs of 5 x 3½-inch

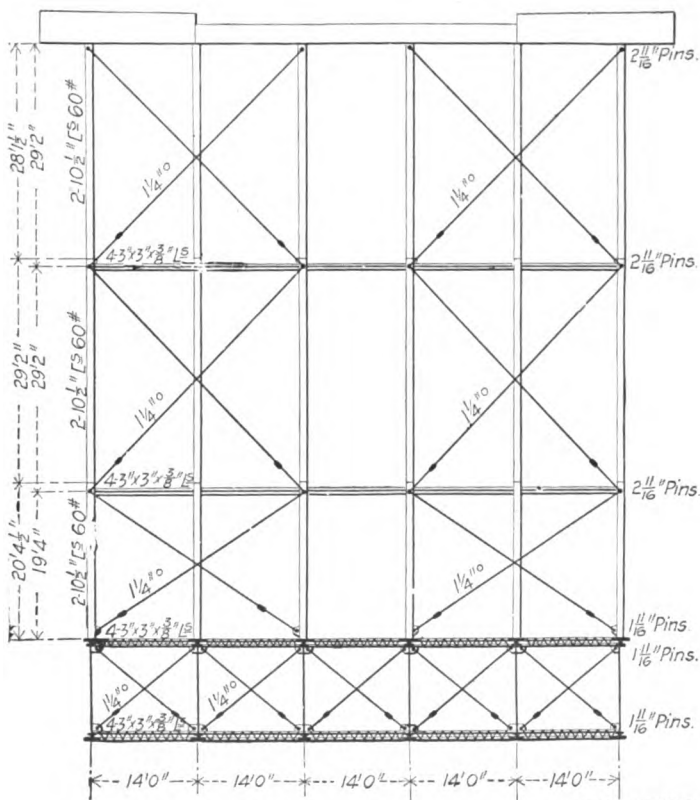

Cross-Section near Skewbacks.

radial web-stiffener angles, which at the ends serve as splice flanges. The web plates are shop-spliced with two vertical rows of rivets at each intermediate stiffener and the stiffener angles are slightly crimped at the ends, and have their web flanges turned in opposite directions on opposite sides of the girder web, so that their combined cross-section is Z-shaped. The field splices of



the arch segments are made with 20-inch flange plates and with fifty-eight rivets through the end web angles.

In the end sections the flanges are curved so that their center lines intersect on the center of the 18-inch skewback pins. The webs are also reinforced and, with the ends of the flange

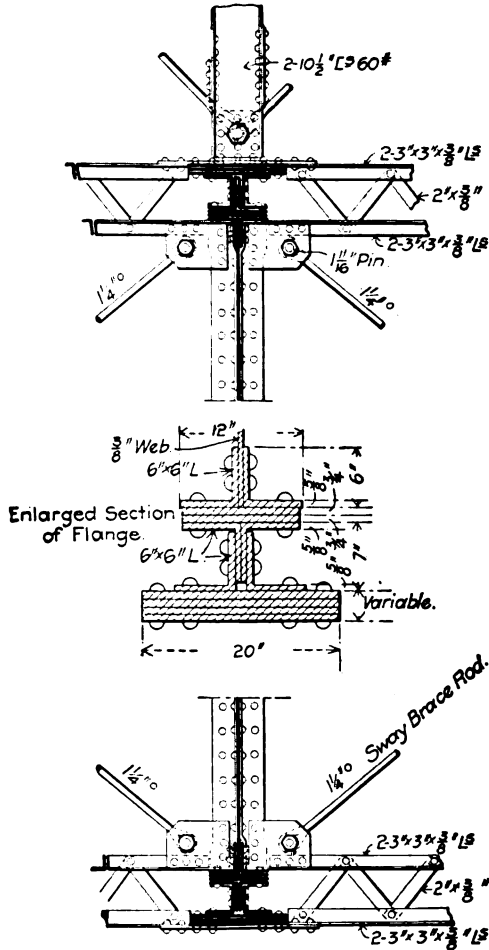

Connection of Braces and Spandrel Post to Arch Rib.

The Engineering RECORD

angles, are planed to a semi-hexagonal bearing for the cast-steel socket, which has a pin bearing of about 170 degrees, 34 inches long. Triangular extensions of the web plates with their upper and lower edges stiffened with narrow flange angles are riveted

to the curved ends of the girder flanges to carry the parallel lines of the flanges to the pedestals which continue them to the pier masonry so that the effect is that of a square ended rib with a full width base on the masonry. The lower pin-bearing casting has a rectangular seat against the reinforced quadruple webs and inclined stiffener angles of the pedestal.

The inner webs of the pedestals are triangular plates, but the outer webs are rectangular plates extended beyond the inclined flange angles to maintain the full width of the arch rib, and correspond with the web extensions of the end segments to which they are spliced by bolts in slotted holes through jaw plates shop-riveted to the girders. The 4 1-3 x 13-foot pedestal bases are

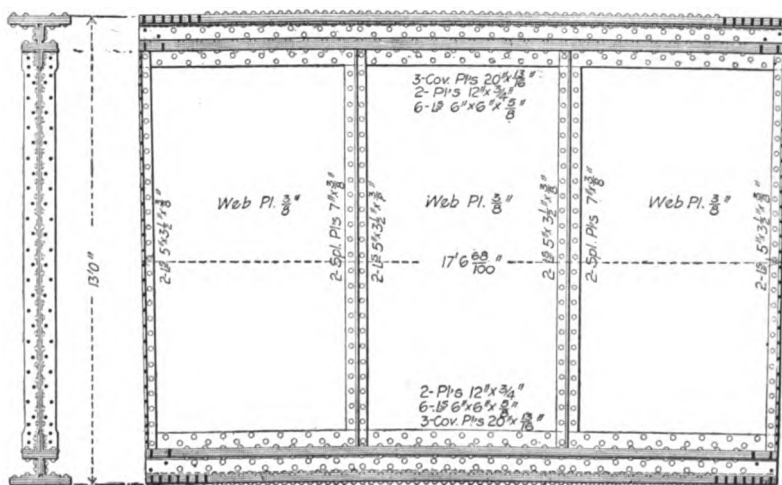

Intermediate Section of Arch Rib.

THE ENGINEERING RECORD.

made of double  $\frac{3}{4}$ -inch plates seated on felt packing and anchored to the granite beds with four 2-inch bolts. The lower end of each bolt screws into a short thick sleeve slightly larger outside at the bottom than at the top. Both bolt and sleeve are enclosed in a split pipe and when the bolt is screw up it draws the tapered sleeve into and expands the split pipe so as to wedge it tight in the drilled hole.

In the shops great care was taken to plane the ends of the segments to the exact angles of the radial joints of the parabolic arch curve, which differed for every segment in the semi-arch. Each segment was put on the planer with its web horizontal and one end was planed to the approximate angle.

The segment was reversed and the edge of the finished end was carefully aligned with a fixed point several hundred feet away, outside the shop, at the intersection of the two radii through the ends of the segment, the other radius being drawn through the cutting line of the tool.

The horizontal transverse struts between the arch ribs are composed of two pairs of angles riveted back to back and latticed,

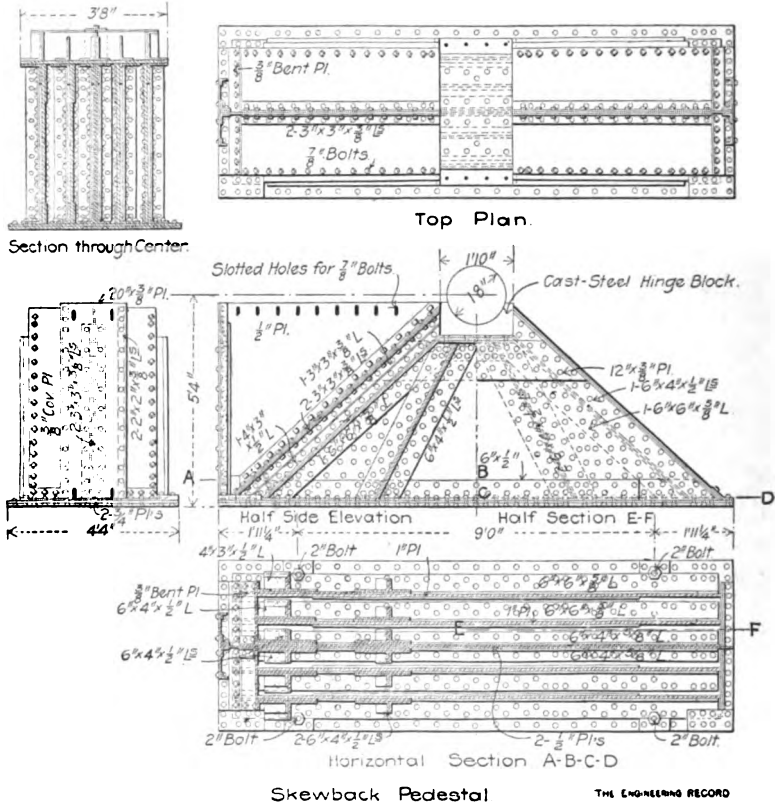

one pair of web flanges being turned in and the other pair turned out. One pair is riveted to horizontal connection plates on the outer flange of the girder, and the other pair is riveted between a pair of vertical plates riveted to the outstanding flange of a vertical web stiffener angle. These plates form jaws to receive the loop end of the sleeve-nut sway diagonal rod, which is pin-connected to them. The wide base plates of the spandrel posts project beyond the top flanges of the arch ribs and are field-riveted to

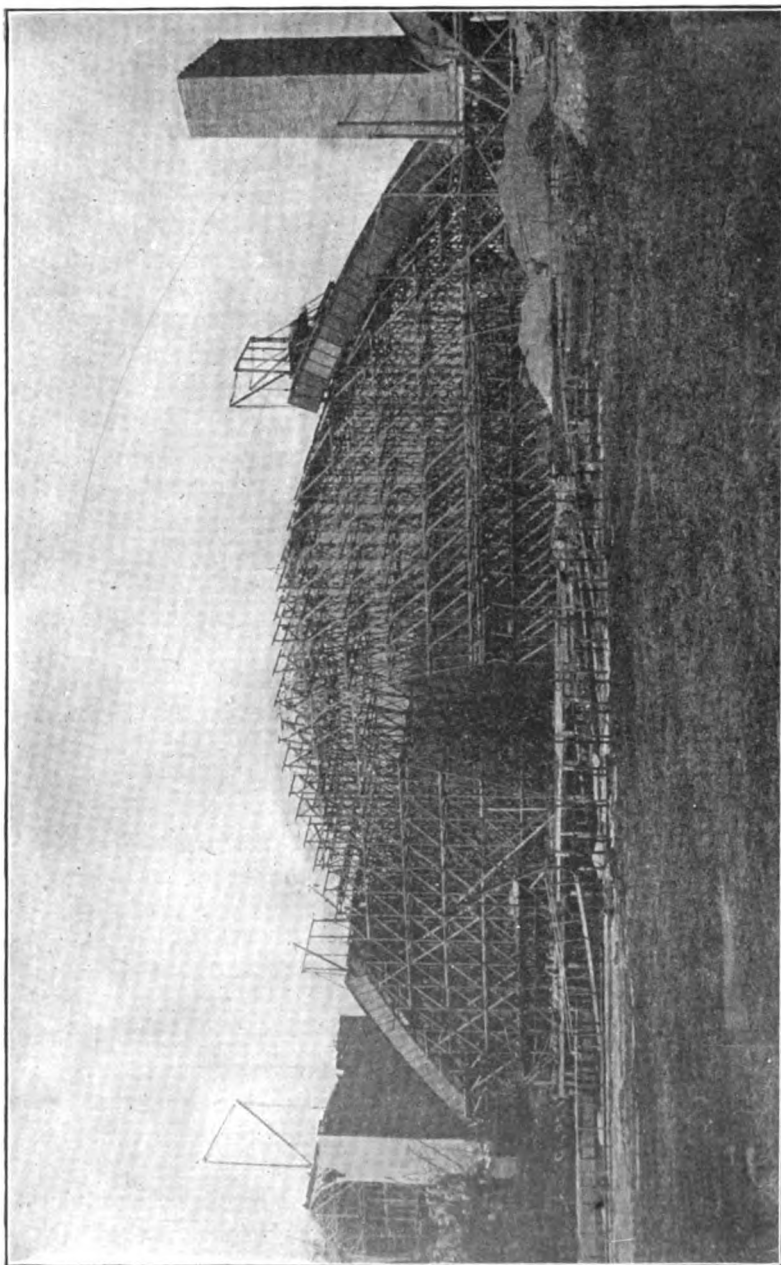

ERECTION OF 510-FOOT ARCH RIBS OF WASHINGTON BRIDGE.

the lateral diagonal angles. The bottom flange connection plates for the lateral struts also receive the ends of the lower lateral angles. The spandrel posts are made with pairs of 10½-inch channels, latticed, and the longitudinal and transverse struts between them have I-shaped cross-sections made with two pairs of angles riveted together back to back and latticed.

The plate girder floorbeams have a center section 42 feet long and two cantilever end sections about 20½ feet long. The center sections are 30 inches deep, and the end sections are 48½ inches deep and overhang the spandrel posts about 6 feet. The three sections are spliced together on the center lines of the spandrel posts by field rivets through their end vertical web stiffener angles. The asphalt pavement and flagstone sidewalks have a concrete foundation on buckle plates carried by I-beam stringers seated across the flanges of the floorbeams. At the piers the floor platform slides longitudinally between guides on a beam grillage anchored to the masonry so as to transmit the lateral stresses to solid reactions. At the outer edges of the sidewalks there is a wide cast-iron cornice on a foundation of 5/16-inch steel plates, bolted to the ends of the floorbeams and to two immediate brackets in each panel. The massive cast-iron parapet has bronze ornaments and lamp posts.

The arch segments were shipped from the bridge shops with the webs vertical and suspended through slots cut in the floors of flat cars so as to clear the tunnel roofs. The arch spans were erected on trestle falsework with bents having six vertical posts supported in the river by piles and on land by transverse sills. The falsework was seven stories high in the middle and had sway bracing between the first and second, the third and fourth and the fifth and sixth posts. Every panel had a single longitudinal brace, except the two panels under the crown. Each semi-arch rib also had two raking braces from the haunches to the ground near the center. The land span had three openings to clear intersecting railroads and streets spanned by plate girders about 45 feet long, which supported the upper bents of regular falsework. The channel span had a center opening of about 80 feet for navigation spanned by two inclined bents on each side and short timber trusses at the top.

Materials were delivered by a balanced cantilever revolving tower derrick to an elevated distributing platform at skewback level alongside the falsework and from there was hoisted and erected by two overhead travelers. Each traveler consisted of

a movable platform with two adjustable braced masts and two booms which commanded the full width of the span. The travelers were seated on the arch ribs and erected them from the skewbacks to the crown, then moved backward from crown to piers at roadway level, erecting the spandrel posts and floor platform. The arch segments were supported during erection by blocking on the falsework caps, and were swung by jackscrews inserted between the girders and caps alongside the blocking. Most of the field splice rivets were driven by pneumatic yoke riveters suspended by differential hoists from grooved wheels rolling on round steel bars, which in turn rolled on the flanges of the horizontal struts. The two spans weigh about 3,342 tons. Their erection was commenced September 1, 1887, and finished May 11, 1888, by an average force of about 200 men. Work on the foundations was commenced in May, 1886, and the bridge was substantially completed in December, 1888, at a total cost of \$2,857,684.55. The erection was described in "The Engineering Record" of July 21 and 28, August 11 and September 1, 1888. Acknowledgment for data of the design is made to Mr. Theodore Cooper, consulting engineer of the Washington Bridge.

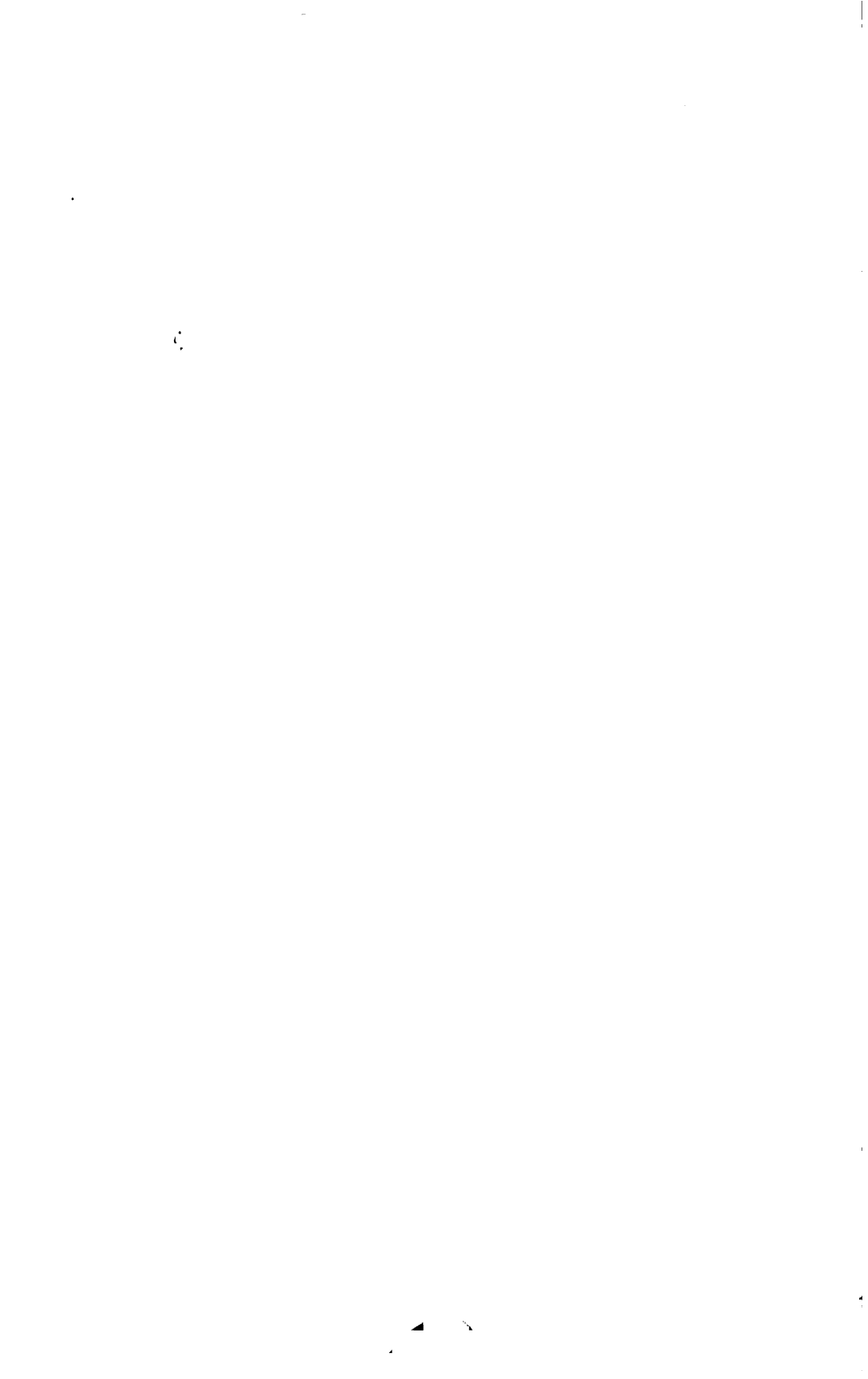

# INDEX.

## TYPES.

	PAGES
PART I. WOOD AND IRON SPANS.....	3 TO 17
PART II. STEEL AND IRON SPANDREL BRACED ARCHES.....	18 TO 109
PART III. STEEL AND IRON ARCH TRUSSES.....	110 TO 208
PART IV. STEEL AND IRON PLATE GIRDER ARCHES.....	209 TO 289

## TITLES.

	PAGE		PAGE
Alexander III., 2-hinge.....	271	Mahoning River, 2-hinge.....	262
Austerlitz .....	212	Main Street, 2-hinge.....	266
Belle Isle Park, hingeless.....	214	Manhattan Avenue, 2-hinge.....	122
Berlin, hingeless.....	19	Marne, 2-hinge.....	227
Berlin, 2-hinge.....	214	Mendota, hingeless.....	13
Bonn, 2-hinge.....	176	Menominee River, 3-hinge.....	37
Brooklyn-Brighton, 3-hinge.....	118	Midi, 3-hinge.....	260
Brunswick, 3-hinge.....	110	Mill Street, 3-hinge.....	229
Buffalo Park, hingeless.....	212	Mirabeau, 3-hinge.....	49
Carlsburg, 2-hinge.....	112	Muscot, hingeless.....	19
Cascade Glen, hingeless.....	14	Niagara Falls and Clifton, 2-hinge....	187
Cedar Avenue, 3-hinge.....	23	Niagara Railway, 2-hinge.....	88
Chagrin River, 2-hinge.....	233	Noce, 2-hinge.....	28
Colossus, hingeless.....	11	North, 2-hinge.....	242
Cornhouse, 2-hinge .....	149	Paderno .....	153
Cornhouse, 2-hinge .....	221	Pan American, hingeless.....	212
Cross River, hingeless.....	19	Panther Hollow, 3-hinge.....	53
Deer Island, hingeless.....	13	Passy, 2-hinge.....	134
Douro .....	186	Piscataqua .....	13
Dusseldorf, 2-hinge.....	182	Riverside Cemetery, 2-hinge.....	113
Driving Park, 2-hinge.....	62	Riverside Drive, hingeless.....	216
Eads, hingeless.....	157	Rio Grande, 2-hinge.....	66
Easton, hingeless.....	9	Rochester, Accident to Cast-Iron Rib	241
Fairmount Park, 3-hinge.....	31	Salmon River, 3-hinge.....	43
Fall Creek, 2-hinge.....	238	Schuylkill Permanent.....	11
Fern Hollow, 3-hinge.....	246	Seine, 2-hinge.....	129
Forbes Street, new, 2-hinge.....	224	Severn, hingeless.....	210
Forbes Street, old, hingeless.....	117	Southwark, hingeless.....	212
Garabit, 2-hinge.....	170	Stony Creek, 2-hinge.....	139
Gruenthal, 2-hinge.....	185	Straubing, 2-hinge.....	185
Harburg .....	185	Surprise Creek, 2-hinge.....	58
Hunslet, 2-hinge.....	212	Trajans, hingeless.....	5
Jefferson, hingeless.....	110	Trenton, hingeless.....	13
Kaiser Wilhelm, hingeless.....	162	Upper Plum Brook, hingeless.....	19
Kanday, hingeless.....	5	Viaur, 3-hinge.....	101
Kintai Kyo, hingeless.....	5	Victoria Gorge, hingeless.....	216
Lake Street, 3-hinge.....	83	Washington, 2-hinge.....	279
Levansau, 2-hinge.....	186	Waterford, hingeless.....	11
Louvre .....	212	Wearmouth, hingeless.....	210
		Worms, 2-hinge.....	185



## CLASSIFIED DETAILS.\*

	PAGES		PAGES
<b>ANCHORAGES.</b>		Kaiser Wilhelm .....	165-70
Fern Hollow .....	253-259	Menominee .....	41-3
Niagara Railway .....	96-100	Niagara Falls and Clifton .....	199-208
Noce .....	29-30	Niagara Railway .....	95-101
Rio Grande .....	75-7	Noce .....	30
Seine .....	133	Rio Grande .....	74-8
Surprise Creek .....	61		
Viaur .....	103, 108	<b>ERECTION, On Falsework.</b>	
<b>CALCULATIONS.</b>		Alexander III. ....	277-78
Fern Hollow .....	248	Bonn .....	181
Mahoning River .....	262	Cornhouse .....	153
Niagara Railway .....	94	Fairmount Park .....	35-7
Panther Hollow .....	54-6	Lake Street .....	87
Rio Grande .....	66, 67, 78-83	Mahoning River .....	263
		Manhattan Avenue .....	126-9
<b>CAST IRON AND CAST STEEL.</b>		Paderno .....	155-156
Alexander III. ....	271	Passy .....	138
Austerlitz .....	212	Rio Grande .....	74-8
Hunslet .....	212	Seine .....	134
Louvre .....	212	Washington .....	288
Marne .....	227		
North .....	242	<b>GENERAL DETAILS</b>	
Severn .....	210	Alexander III. ....	271-4
Southwark .....	212	Berlin .....	19-22
Wearmouth .....	210	Berlin .....	214, 215
		Bonn .....	176-80
<b>CENTER PANEL, HINGELESS.</b>		Brooklyn-Brighton .....	119-21
Belle Isle .....	213	Brunswick .....	110
Berlin .....	215	Carlsburg .....	112, 113
Buffalo Park .....	211	Cedar Avenue .....	24-28
Chagrin River .....	235	Chagrin River .....	233-36
Cornhouse .....	223	Cornhouse .....	149-55
Fall Creek .....	239	Cornhouse .....	221, 222
Forbes Street .....	225	Cross .....	19-21
Rio Grande .....	69, 72	Driving Park .....	62-5
Riverside Drive .....	216	Eads .....	157-61
		Fall Creek .....	238-40
<b>CROWN HINGE.</b>		Fairmount Park .....	31-35
Alexander III. ....	273	Fern Hollow .....	249-56
Cedar Avenue .....	26	Forbes Street .....	224-6
Driving Park .....	63	Garabit .....	171, 173, 174
Fairmount Park .....	34	Jefferson .....	111-112
Fern Hollow .....	251	Kaiser Wilhelm .....	163-5
Lake Street .....	86	Lake Street .....	83-7
Main Street .....	267	Main Street .....	266
Menominee .....	40	Manhattan Avenue .....	122-5
Mill Street .....	232	Mahoning River .....	268
Mirabeau .....	53	Marne .....	227-9
Panther Hollow .....	58	Menominee .....	38-41
Salmon River .....	44	Midi .....	260, 261
Stony Creek .....	142	Mirabeau .....	49-51
Viaur .....	108	Muscoot .....	19-21
		Niagara Falls and Clifton .....	198-99
<b>ERECTION, Cantilever Method.</b>		Niagara Railway .....	88-91
Eads .....	159-61	Noce .....	28-30
Fern Hollow .....	256-59	North .....	242-6
Garabit .....	175	Old Forbes Street .....	117, 118

\*NOTE—Arch types are not here designated, since they can be determined by inspection, remembering that all references to pages 18-108 are to Spandrel Braced Arches, 109-208 are to Arch Trusses, and 209-289 are to Plate Girder Arches.



## CLASSIFIED DETAILS.

PAGES		PAGES	
<b>PEDESTALS FOR SK'WB'KS—Cont.</b>			
Old Forbes Street.....	117-18	Fairmount Park .....	35, 37
Panther Hollow .....	58	Fern Hollow .....	249-50
Passy .....	138	Forbes Street .....	226, 227
Rio Grande .....	74, 75	Mahoning River .....	264, 265
Riverside Cemetry .....	115-16	Main Street .....	267
Salmon River .....	46, 47	Menominee .....	41
Seine .....	133	Mill Street .....	232, 233
Stony Creek .....	144, 145	Niagara Falls and Clifton.....	196-201
Surprise Creek .....	61	Panther Hollow .....	58
Viaur .....	106-7	Rio Grande .....	74, 75
Washington .....	286	Riverside Cemetry .....	115, 116
<b>PIN CONNECTED SKEWBACKS.</b>			
Alexander III. ....	274-75	Salmon River .....	46
Bonn .....	181	Seine .....	133
Carlsburg .....	113	Stony Creek .....	144, 145
Cedar Avenue .....	26	Washington .....	285, 286
Chagrin River .....	237	<b>WEB CONNECTED SKEWBACK.</b>	
Driving Park .....	64	Riverside Drive .....	219-21
Fall Creek .....	240	<b>TEMPERATURE ADJUSTMENT.</b>	
		Noce .....	29

## TIMBER ARCHES.

PAGES		PAGES	
<b>SOLID-RIB ARCHES.</b>			
Kanday .....	5, 6	<b>ARCH TRUSSES WITH DIVERGENT CHORDS.</b>	
Kintai-Kyo .....	5, 7, 8	Easton .....	9
Pan American .....	212	Colossus .....	11
Trenton .....	12, 13	Schuylkill .....	10, 11
Waterford .....	11	<b>ARCH TRUSSES WITH PARALLEL CHORDS.</b>	
		Mendota .....	13, 14
		Cascade Glen .....	14, 17

H. G.

H. M.

