

Interior of the Western Union operating room, Chicago office. The operators occupy the ninth and tenth floors of the Western Union building. The rooms are 46 x 212 feet, and accommodations are provided for 880 operators. The number of messages handled here average 2,327,436 a month.

SECOND EDITION

TWENTIETH CENTURY  
MANUAL

OF

RAILWAY AND  
COMMERCIAL

TELEGRAPHY.

BY FREDERIC L. MEYER.

---

RAND, McNALLY & COMPANY, PUBLISHERS,  
CHICAGO AND NEW YORK.

Copyright, 1902,  
by Rand, McNally & Company.

6700707

75719  
JAN 14 1904

TQ  
M57

## PREFACE.

---

In presenting the Twentieth Century Manual of Telegraphy, attention is called to the fact that the Manual is not the work of a few days, but it is the result of many years of observation and close study of telegraphy in all its phases.

It is not the work of an inexperienced telegrapher, but it is the achievement of the author, whose experience covers a period of fourteen years on some of the fastest wires of the United States, Canada, and Mexico.

Great caution has been exercised to eliminate such matter as would burden the student with theories, the aim being to embody in its pages only practical instructions, using practical forms as they must eventually come in active work, so arranged that they will guide the student steadily along.

Dispatchers, operators, managers, and prominent officials have been drawn upon for phrases, practical train orders, and railway and commercial messages. A careful selection has been made from a large amount of material gathered together. Each and every form has been fully explained and divided into parts, and every effort has been made to make them plain. The different forms have been compiled systematically in every detail.

The work touches all kinds of practical orders, messages, and phrases, and contains universal abbreviations, punctuations, and other compilations of vital importance to both student and operator, covering a great many branches of the railway and commercial business unknown to the average operator who has not had an opportunity to work on more than one or two roads.

There has been an endeavor to present the various forms with a fullness, yet conciseness of explanation, and completeness of illustration, that makes them thoroughly practical.

Beginning with the alphabet, the work has been arranged as it has naturally come to our greatest operators. To make the student's progress gradual, the first thing he masters in the practical office, the things that first come to his ears as he studies, and the first things he will get a chance to do under the teacher or operator, are properly arranged and lead from one to another in logical order.

To teach the alphabet is not enough. The student must have the correct punctuations, which in telegraphy are entirely different from the manner in which they appear in print. He must know how to use some punctuations for signs, and how to abbreviate his words. He must learn the technical laws governing sending and receiving operators. Were these points mastered by the average operator, countless failures would be saved.

In these days, correct forms and correct copies are absolutely necessary. To understand how to save time, and to transmit and receive messages,

specials, and train orders so that they will bear the same technical form as the original copy, are requisites in modern telegraphy.

Owing to the obsolete, incumbering matter contained in the only available text books on practical telegraphy, as it is sent and received over the wires, the author believed it necessary to prepare this work.

The thanks of the author are cheerfully extended to all who, during the past years, have worked so zealously for the success of the undertaking. For some of the cuts used in this work he is indebted to the Western Electric Company, and for the telegraphers' script to Mr. W. Anderson, the well-known teacher of this penmanship.

FREDERIC L. MEYER.

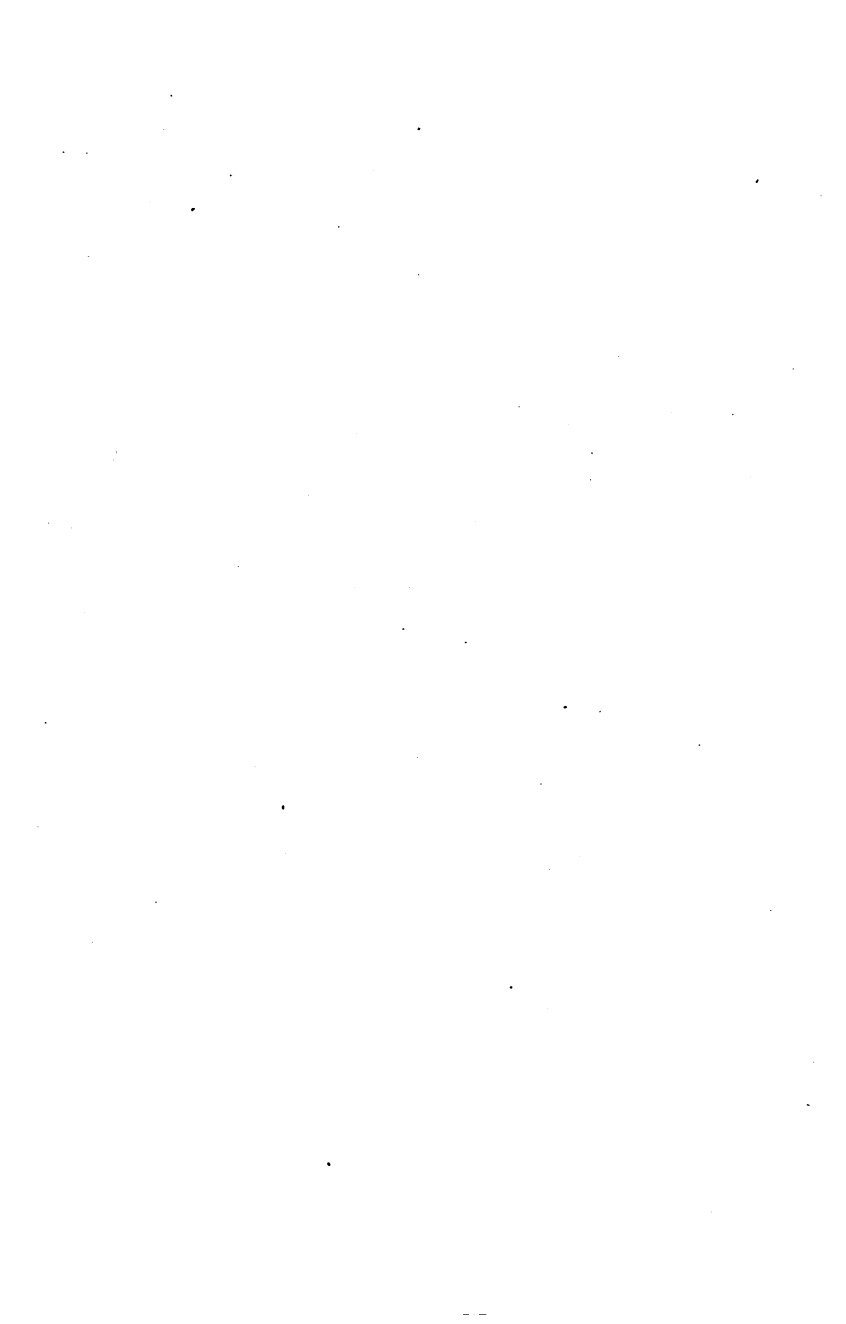



# CONTENTS.

---

## PART I.

### Elementary Electricity.

Lesson

- I. Instructions for Beginners. Electricity. Student's Outfit. Battery Employed.
- II. Electro-Magnetism.
- III. Instruments Employed. Resonators.
- IV. Circuits.
- V. Faults. Interruptions. Wire Testing.
- VI. Cut-outs. Switch-boards.

## PART II.

### The Morse System of Telegraphy.

- I. The Morse Alphabet.
- II. Translation.
- III. Orders.
- IV. Manipulation. Position.
- V. Exercises in Manipulation.
- VI. Sending. Sending Exercises.
- VII. Simple and Compound Punctuations. Explanations.
- VIII. Receiving.
- IX. Telegraphers' Penmanship.

## PART III.

**Commercial Business.**

Lesson

- I. Office Calls. Operator's Signals. Transmission. Form of Sending Messages.
- II. Receiving Messages. Explanation of Forms. Acknowledgment of Receipt. Breaking and Copying.
- III. Commercial Abbreviations. Wire Testing Abbreviations.
- IV. Service and Office Messages.

## PART IV.

**Beginning Railway Telegraphy.****General Instructions.**

- I. Schedule and Numbers. OS'ing Trains. Movement of Trains by Telegraphic Orders.
- II. Sending Orders on Wire. Repetition of Orders. Order Form.
- III. Beginning Telegraphic Orders. Abbreviations.
- IV. Numeral Signals. Explanations. Form of "19" "X" Order. Explanation of "X" Response. Order Form. Definitions. Trains, How Designated. Technical Terms. Special Order "Rights."
- V. Practical Railway Messages.
- VI. Railway Wire Abbreviations.
- VII. Abbreviations Used in Railway Messages.
- VIII. Railway Station or Fixed Signals. Train Signals.

## PART V.

**Advanced Railway Business.**

Lesson

- I. "31" Train Orders. Various Forms Used.  
Practical Work.
- II. "31"—"X"—Orders. Explanation of "X"  
Response and Work.
- III. Standard Train Order Forms.

## PART VI.

**Block Signaling and Examination.**

- I. Block Signaling. Caution Cards. Releases.  
Cross-overs.
- II. Block Record Sheet.
- III. Block Examination.

## PART VII.

**Technical Orders and Telegraphic Reports.**

- I. "31"—"X"—"13" Orders. O. K. Instead of  
Complete. Explanations.
- II. Technical Messages and Telegraphic Reports.  
Practice and Origin.
- III. Car Reports. Practical Hints.

## PART VIII.

**Advanced and Expert Commercial Telegraphy.**

- I. Technical Messages. Special Delivery. Govern-  
ment and Deadhead Business. Grain and Ser-  
vice Messages.

ADVANCED AND EXPERT COMMERCIAL TELEGRAPHY—  
CONTINUED.

## Lesson

- II. Office Messages. Code, Cipher, and Duplicate Business. Night Messages.
- III. Forwarding, Forwarded, Extra Date, Other Line, Query, and Combination Messages.
- IV. Cablegrams, More Than One Address, Number Service Messages.
- V. Commercial News Department. [C. N. D's]. Grain and Provision Abbreviations. Option Months. Grain, Provision, and Live Stock Quotations. Time, Order, and Forms.
- VI. Government Signals [Agricultural Department]. Race Specials, Form and Explanations. Associated Press Special. Code and Full Copies. Box Score [Baseball Special].
- VII. Tariff Book. Tariff Sheet. Words to be Counted and Charged for.
- VIII. Delivery Department.
- IX. Accounts, Reports, and Remittances. Insured Messages. Telegraphic Notes.

# PART I.

## LESSON I.

### Instructions for Beginners.

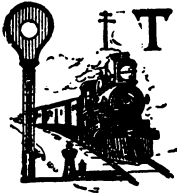

**T**ELEGRAPHY requires careful, methodical drill and study, and great results can not be expected from little labor. "Whatever is worth doing at all is worth doing well." You are entering a profession that recognizes superiority more quickly than any other, and a profession that recognizes only ability.

Follow the instructions carefully. If you start well you will have no trouble to "get up." You have plenty of time, and as you are laying the foundation for your entire future, be sure to lay it well.

Do not aim to do your work as *well* as anyone else, but a little *better*, and then you will be picked out for promotion before anyone else.

Do not pass a point until you are sure that you are master of it. Nothing is gained by rushing hurriedly over the ground. One point neglected in the early part of the text may lead to endless difficulties.

To master one's profession is to put one's self in the line of promotion. It is more than that, it is to command promotion. The really competent man rarely has his abilities overlooked. He is rather the one who is being sought. His study and preparation,

in order to fit himself for good work, will be found to have trained his mind and elevated his moral force to the point of favorable recognition by his official superiors. There is a place always waiting for good and capable men.

The reward may not come when or where it is expected. It may not be always in telegraphy that operators shall find the advancement they feel to be their just due, although from the telegraphic field itself the companies must primarily look for their future officials; but if not, then in other and analogous callings, where the pecuniary reward may be even higher.

No lasting promotion will come without fitness.

### Electricity.

*What is electricity*—A polar force which becomes discernible by its peculiar phenomena of *attraction* and *repulsion*. Two dissimilar metals brought in contact produce opposite kinds of electricity on the surfaces, one becoming *positively*, and the other *negatively*, electrified. It is regarded as a mode of molecular motion.

*From what was the name derived*—The Greek word signifying *amber*, the body on which it was first discovered, when rubbed upon fur, wool, or silk, acquiring the property of attracting light objects. The force of electricity was known 600 years before Christ, but no advance was made in the science for 1,600 years.

*Name the properties of electricity*—In its natural, unexcited state it does not exhibit its

properties, because in that state it makes no manifestations of itself.

*What does it possess when excited*—The power of attraction and repulsion.

*How developed*—In two ways, by chemical action and by friction.

*What are the algebraic signs for positive and negative electricity*—The sign [ + ] for positive, and [ - ] for negative.

### Student's Outfit.

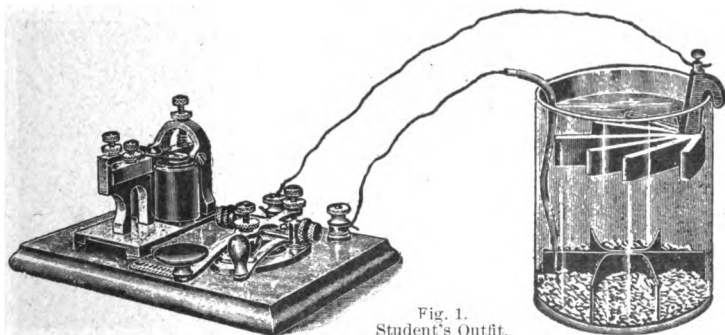

Fig. 1.  
Student's Outfit.

In Fig. 1 we have a student's "set," that is, key and sounder on one board. It is connected with what is known as the gravity battery. The instrument has two posts from which wires run to the battery. One wire runs to the zinc where it is connected with a thumb-screw, the other runs to the copper which is connected by being twisted together. The copper should be bent in the shape shown in Fig. 2.

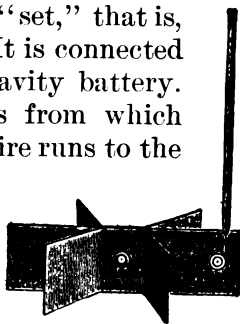

Fig. 2. Copper.



Fig. 3. Crowfoot.



Fig. 4. Star.

There are two styles of zincs, the Crowfoot, Fig. 3, and the Star, Fig. 4.

In making up your battery the blue vitriol should be placed around the copper as in Fig. 1, and water poured into the jar until it covers the feet of the zinc.

Where dry battery is used it is best to unscrew the key lever and always leave the circuit open, as dry batteries run down in a short time if the circuit is kept closed.

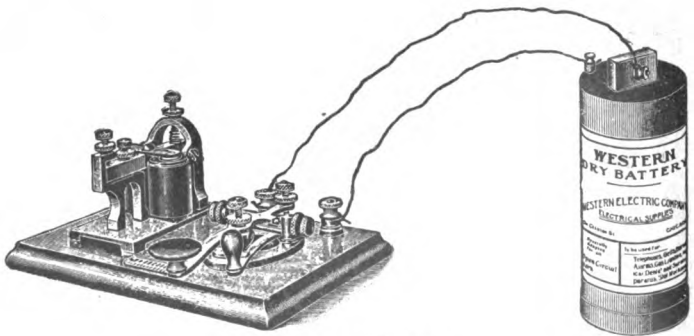

Fig. 5. Dry Battery.



## Battery.

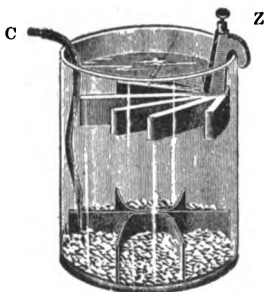

Fig. 6. Gravity Battery.

*What kind of battery is generally used in the telegraph service*—The gravity battery is generally used for the production of an electric current which develops by chemical action.

*What are gravity batteries*—Two fluid cells. Instead of employing a porous cell to keep the two liquids separate, it is possible, where one of the liquids is heavier than the other, to keep the latter on the bottom and have the lighter floating upon it; this separation, however, is never perfect, the heavy liquid slowly diffusing upward.

*How are these batteries made up*—By copper sheets being placed in the bottom of a glass jar with a zinc suspended about four inches above the copper. About six to eight ounces of blue vitriol in small lumps are dropped into the jar around the copper and enough clean water poured into the jar to cover the zinc.

*How is the current generated*—It starts from the positive zinc plate, flows through the fluid to the copper plate, and through the external circuit and back to the zinc plate. The copper strip, whence the current starts on its journey through the external circuit, is called the *positive pole* [ + ] and the zinc strip is called the *negative pole* [ - ]. When the external circuit is broken no current flows, but still the wire connected to the positive pole (copper plate) is called the *positive wire*, and the wire connected to the zinc pole, the *negative wire*. As in almost all commercial batteries, zinc is used as one pole, it may be well to remember that the *zinc pole* is always the *negative pole* and the *copper plate* is the *positive pole*. However, they are more commonly called *zinc batteries* and *copper batteries*.

### **Conductors and Insulation.**

*Meaning of conductors and non-conductors*—Bodies which conduct readily are termed *conductors*, and those *non-conductors* which conduct slowly.

*Name the most common conductors*—Metals, water, and animal bodies.

*Name the most common non-conductors*—Glass, rubber, ice, porcelain.

*Explain the meaning of insulation*—Where a body is separated from surrounding objects in such a manner that it neither receives nor imparts electricity. A body is insulated by being surrounded and supported by non-conductors.

## LESSON II.

### Electro-Magnetism.

Electro-magnetism is that force in nature which is developed by the influence of electric currents. A natural magnet is an iron ore known as lodestone, while an artificial magnet is a bar of steel magnetized by artificial means.

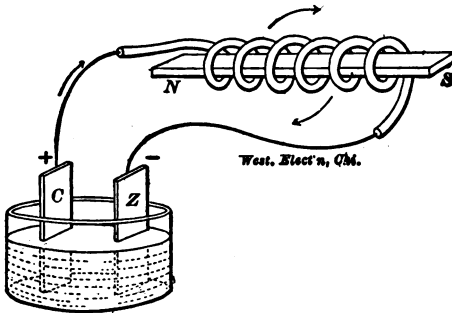
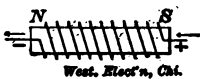

Fig. 7. Magnetized Iron Bar.

When the current is passing through a circuit, spirally coiling around a soft iron bar, the bar becomes an electro-magnet. The separate turns of wire must not touch each other on the iron bar, as this would cause a short circuit through which the current would pass. The wire must be insulated.



Right Hand Wound.

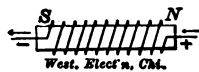

Fig. 8. Left Hand Wound.

The iron bar is a magnet only as long as the current flows. It receives and parts with it rapidly. It may be produced and destroyed several thousand times in a second. Soft iron magnets for this reason are altogether used for telegraphic purposes, the magnets being under control.

The electro-magnets used for telegraphic purposes consist of two cores of soft iron, upon which are wound insulated copper wire, each core covered with rubber in the shape of two spools, the iron cores being screwed to a connecting iron bar known as the "heel piece." The spools are wound in the same direction and both *inside* ends should be joined or the current through one helix would neutralize the effect of the other and no magnet be produced. The other ends should lead to the instrument posts for attachment to battery or line.



Fig. 9.  
Electro-Magnets.

*What effect has the current upon electro-magnets*—Passing through the turns of the wire around the soft iron cores within, these iron cores become magnetized by the inductive influence of the electric current and possess the power of attracting, with considerable force, the armature or piece of iron which is kept just short of reaching the poles or ends of the cores, as when it is in contact a residuum of the induced magnetism lingers in it and in the cores after the current ceases to flow. Held away thus, this attractive power ceases the moment the current ceases.

## LESSON III.

**Instruments Employed.**

Fig. 10. The Key.

The key is a mechanical device for opening and closing a circuit.

*Describe its principal features* — A metallic lever on a trunnion, supported by screws in the elevated sides of a metallic base.

On the bottom of this base are two metallic screw posts to receive the ends of wires. One post is separated from the other by non-conducting material — generally vulcanized rubber, which runs around the point in the front part of the key. In the center of this is fastened a small piece of platinum, and directly above it on the under side of the key lever is fixed another piece of the same metal.

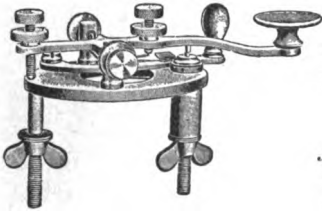
One being insulated from the other, the current can not pass between them, except while the lever is pressed down, bringing together the two platinum points, which are in reality the two ends of the wire. A spring is employed to keep these two points separated.

*How is the circuit kept closed* — By a circuit closer, or movable bar, so situated as to slide under a lip, thus keeping the wire electrically connected while the key is not in use.

## The Relay.

*Of what does the relay consist*—Of a bar or armature so arranged as to be free to move when acted upon by an electromagnet, and which, when moved, closes a local battery circuit through the sounder connected with the relay.

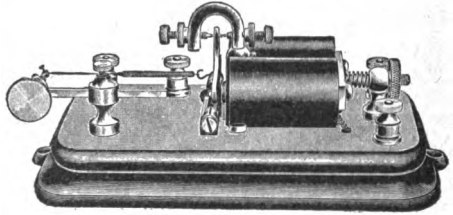

Fig. 11. The Relay.

*Is there any communication of electricity between the local and main circuit*—None whatever; the relay establishes a mechanical and not an electrical connection.

*Name the three essential parts of the relay*—

1st. Two helices of insulated wire enclosing two bars of soft iron connected by a yoke.

2d. An armature attached to a movable lever and situated near the open ends of the soft iron bars.

3d. Two platinum points, one being fixed on the armature, and the other to the brass frame in such a manner that the movements of that lever separate or unite them, opening and closing the local circuit.

## The Sounder.

*What is the sounder*—The instrument employed in receiving messages.

*Of what does the sounder consist*—Simply two upright electro-magnets, an iron armature attached to a movable lever fixed upon a frame elevated above the base, with a spring attached to the lever which must be adjusted in proportion to the strength of the current. It is regu-

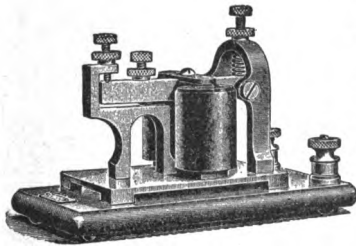

Fig. 12. The Sounder.

lated by two adjusting devices, one stopping the movement toward the magnets which gives the sound, the other limiting the movement of the lever away from the magnet by the spring.

### Resonators.

Resonators are used by all large commercial offices, as the sounder incased in them greatly increases and concentrates the sound, making it possible to read readily from a

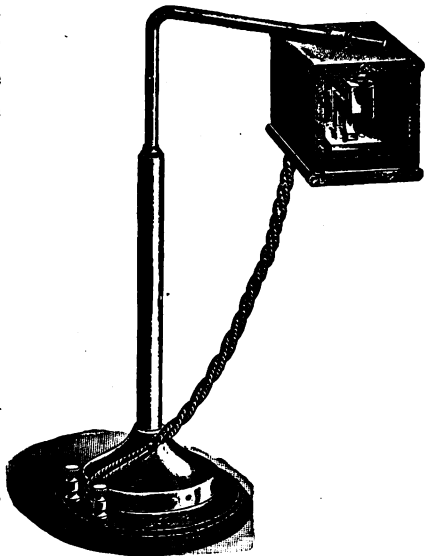

Fig. 13. Adjustable Resonator.

certain sounder, without affecting the work at other instruments, the sound being entirely confined to the instrument. It is especially adapted for receiving operators using the typewriter, or for all situations where the sound of the instrument is subject to outside interference.

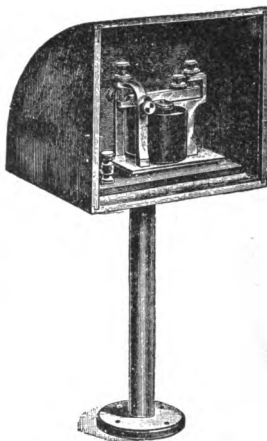

Fig. 14.  
Stationary Resonator.

## LESSON IV.

### Circuits.

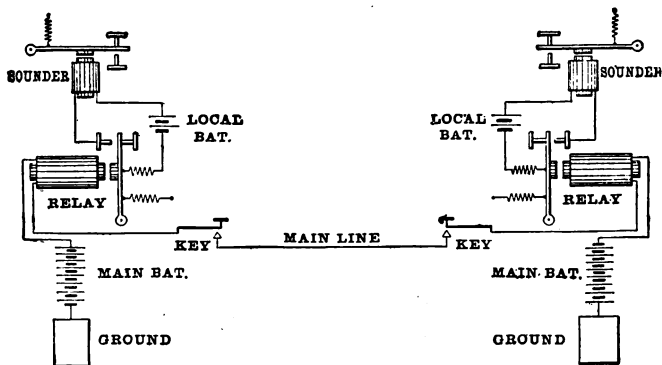

Fig. 15. Circuits.



*Name the two classes of telegraphic circuits —*  
Main and local.

*Define the main line —* The main circuit extends the entire length of the line, of which the wire between offices forms a part.

*What part of a main line does the earth form —*  
It is used instead of a return wire, as in the case of a local circuit.

*Explain how this is accomplished —* Commencing at one terminal station at the earth, *i. e.*, with a ground wire connected to a rod driven several feet into the ground, the wire runs from this rod into the battery room and is connected to one pole of the battery; then from the other pole of the battery a wire is connected to one of the legs or binding screws of the relay; a third wire extending from the other post of the relay is connected to one of the binding screws of the key; from the other key post a fourth line runs along the route, being insulated from the poles by glass knobs to keep the current from passing to earth until the wire reaches the way, or intermediate offices, where it runs through the key and relay, but not to ground until it reaches the other terminal office, where it enters the office, runs through the key and relay, then to the battery, and again connects with the earth; as the earth now joins both ends, it completes the circuit, the earth yielding up to one end of the line as much as it receives from the other, without permitting any "increase" or "decrease" of its electricity.

Where a switch-board or cut-out is used, the main line wires are run into the office to the screw posts at the board, and from there to the instruments.

*Define the local circuit*—It is a snort circuit confined to the office, which, starting from the battery, goes through the armature lever of the relay and its frame, and the helices of the sounder back to the battery, its extent from instruments to battery being limited to a few feet.

*How are the instruments connected*—The local or sounder with the relay, the key with the main line, and the relay with the key, sounder, and main line.

*What is the key for*—To close and open the main circuit, which operates the relay.

*How does the relay act upon the local circuit*—It closes and opens it, which operates the sounder.

*How are wires connected or spliced*—Two wires are firmly wound around each other, the different convolutions touching one another and passing as near as may be at right angles with the wire which they surround.



Fig. 16. Spliced Wires.

## LESSON V.

### Faults, Interruptions, and Wire Testing.

*To what are interruptions due*—Every shower, fog, mist, sleet, high wind, and contact with other wires.

*What is a disconnection or break*—Where the continuity of a circuit is ruptured, causing a cessation of the flow of electricity.

*Give meaning of an escape or leakage*—Where the current escapes from the line to the ground by defective insulation, or contact with some conductor leading to earth.

*What causes a cross*—Two wires coming in contact, in such a manner that one can not be worked without interfering with the other.

*How is perfect communication restored when wires are crossed*—By opening one and handling business on the other wire, which will not then be affected.

*What causes a weather cross*—A leakage of current from one wire to another in wet weather, caused by defective insulation.

*What is a swinging cross or contact*—One wire swinging against another but remaining in contact but a short time.

*Give meaning of wire-testing*—Proving the electrical condition of wire.

*How is this accomplished*—By calling the terminal offices and establishing communication.

*How is trouble located*—By calling up operators at various way-stations and asking them to connect their ground wire for a few seconds, first on one side of the instruments, and then on the other. If either connection closes the line circuit, the interruption is on that side, as the current of the opposite battery is complete through the ground.

*What is meant by "put No. 1 east to 2 west" —* To so connect the wires that they will work through your office in the directions named only, as one wire.

*Give meaning of "straighten 1 and 2" —* To restore the wires to their usual condition, or at times to take off ground wire.

## LESSON VI.

### Plug Cut-outs.

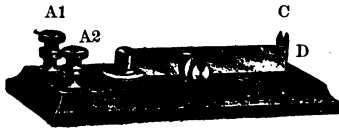

Fig. 17.

This is an old and simple form of cut-out apparatus for a way-office on a single wire. The line wires are brought to the terminal A1 and A2 (Fig. 17). A1 is connected with a vertical pin C, fixed in the wooden base. A2 is connected with a metallic spring D, which carries a pin D, against the fixed pin C, and thereby connects the lines A1, A2. The insertion of a plug, as shown in the following cut (Fig. 18), by the two pins, causes the movable pin D to press against the E side of the plug. These sides are connected with the relay of the office by wires whose ends are clamped over the screws G and H. The insertion of the plug, therefore, interposes the instruments between the two

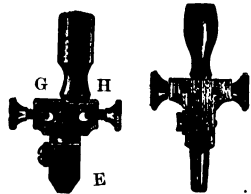

Fig. 18.

Plug Cut-outs.

terminals A1 and A2; and, consequently, in the line circuit by the withdrawal of the plug, the spring D snaps against the pin point C and directly connects the lines and removes the circuit from the relay.

### Switch-Board.

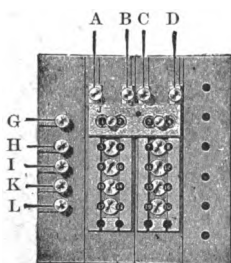

Fig. 19. Two-Circuit  
Way-Switch.

A switch-board for two separate lines, outgoing and incoming, from a way-station is represented in Fig. 19. Here the lines are connected to the terminals A, B, C, D, and with the strips and lightning arrester J. All the circular pieces in one horizontal row are connected to one terminal, as at H. The row below it and the terminals K, L, are connected to the lowest pair of circular pieces between each pair of strips. By this means, a pair of thin plugs can be inserted in any diagonally adjacent pair of holes, so as to press the instrument or the given pair of terminals, in connection with a given pair of lines. For example, by inserting plugs in the intersections C and K, and D and L, the instrument that belongs to the local section K, L is inserted in the line of C, D. It is customary to have a board wired in such a manner that the plugs are normally inserted in a diagonal line across the board, thus connecting lines A, B to instrument H, I, and lines C, D to instruments K, L. G is the current terminal for the plate and lightning arrester J, and is a wire to ground.

## Loop Peg and Cord.

Connections on large boards are in some instances made by inserting a double plug in one of the holes between a disc and a strap.

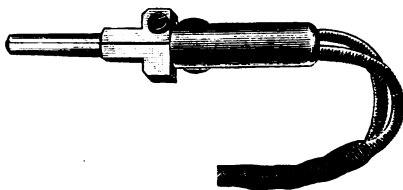

Fig. 20. Loop Peg and Cord.

This plug is made in a similar manner to the plug used in a "cut-out," Fig. 18, excepting it has a round nose.

A double plug for switch-board purposes is represented in Fig. 20.

It is commonly called the "loop peg," being used to loop in an instrument. It is generally used for testing.

In Fig. 21 is shown a 50-strap spring-jack board. These boards are used to advantage in large commercial and terminal offices, where battery connections are made with the line. They are constructed in such a manner that changes in the disposition of either wires, desk instruments or kind (positive or negative electromotive force) can be made instantly, with ease and without causing interruptions.

*Example:* One row of discs across the board is connected to a sixty-cell copper "positive" battery, which, in turn, runs to ground; another row of discs connects with the zinc or negative battery of the same amount, and the next twice the amount of copper as the first, and so on until several hundred cells are reached. Wherever a strap is connected

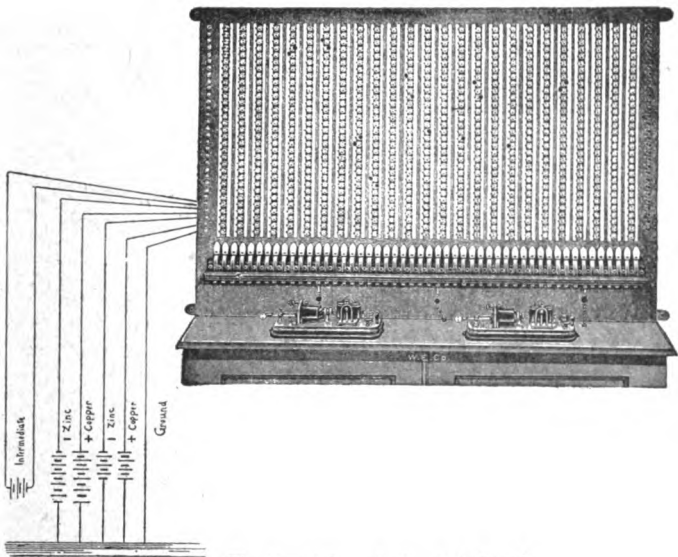

Fig. 21. 50-Strap Spring-Jack Board.

with a disc by the insertion of a pin-peg, it is supplied with the electromotive force of positive or negative polarity designated on that line.

In case of a "through" wire, which does not terminate at the office, it is sometimes necessary to use an intermediate battery, which is connected to two rows of discs, one to the positive and the other to the negative pole.

The spring-jack is used in establishing the connection of instruments with the circuits, each line wire entering at the back of, and at the bottom of the board and being attached to post Y at the lower end of the spring-jack. A flat plug having two

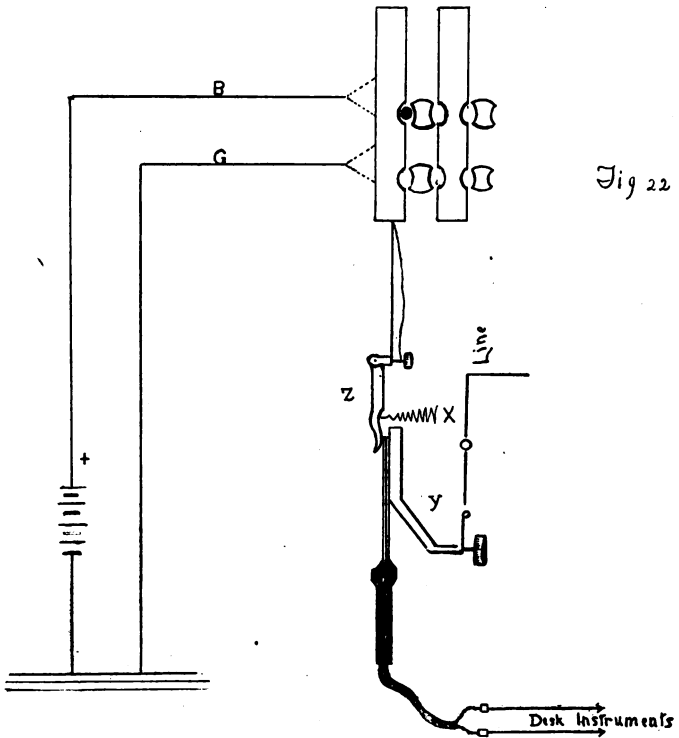

Fig 22

Fig. 22.

metallic sides separated by a piece of hard rubber, with a cord attached, containing two wires connected to the metallic sides, is inserted in any of the spring-jacks on the board. The insertion of the plug raises a spring lever, thereby breaking the metallic connections between the jaws of the jack and allowing the circuit to go through the instruments which are connected through the cord.



When the plug is withdrawn the jack Z rests in contact with the base Y through the influence of the spring X. By inserting a pin-peg between a disc and a strap, the kind and amount of battery or force is supplied.

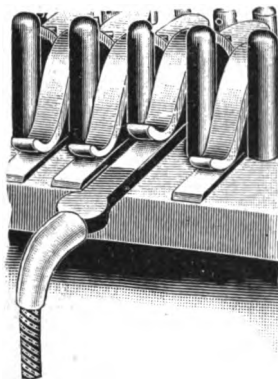
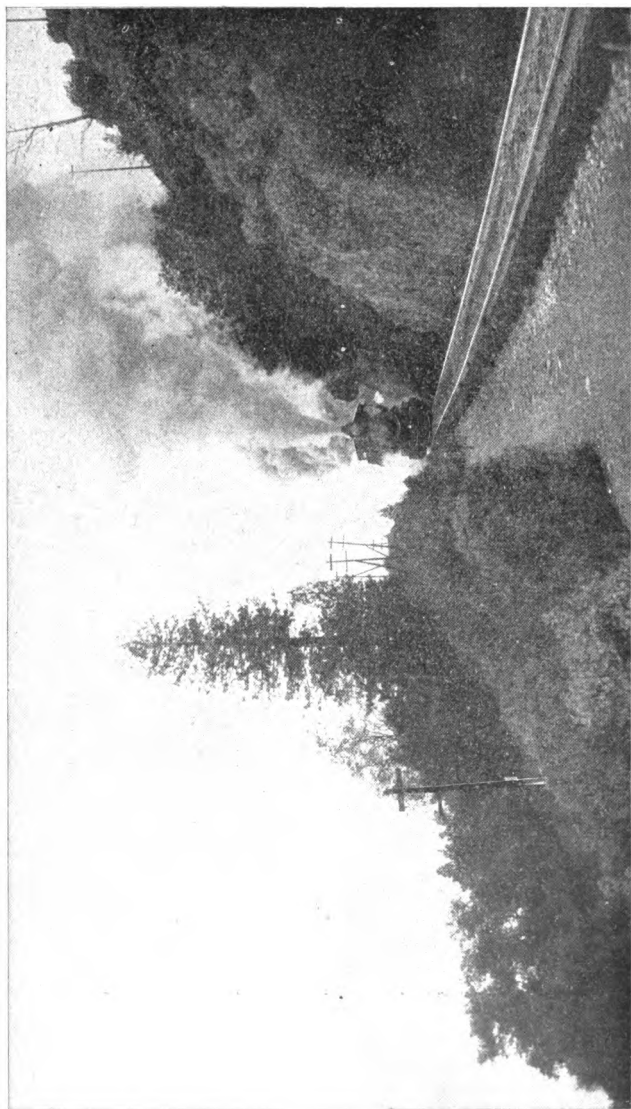

Fig. 23. Section of a Switch-Board, showing spring-jack and plug.



A telegraph operator's mistake would be disastrous at this point.

## PART II.

---

### LESSON I.

#### **The Morse System of Telegraphy.**

The Morse alphabet, which is employed to represent the sounds used in telegraphy, is composed entirely of linear characters formed of dots and dashes, and by the combination of the two: the former being an instantaneous closing of the key, while the key is held for the latter. Examples:—dot [·], dash [—]. The letters C, O, R, Y, and Z, and the symbol “&” are composed of dots and spaces. There are no spaces in any of the letters composed of dashes.

#### **The Morse Alphabet.**

The student should commit the alphabet to memory before attempting the punctuation marks.

Each character of the alphabet should be thoroughly impressed upon the memory without reference to the position of other characters, so that the mind has nothing to do but to attend to the mechanical movement.

**Alphabet.**

A	B	C	D	E	F
..	....	.. .	....	.	....
G	H	I	J	K	L
....	....	..	....	....	---
M	N	O	P	Q	R
---	---	..	.....	.....	.. .
S	T	U	V	W	X
....	-	....	....	....	.....
Y	Z	&			
.. .	.... .	.. .			

**Numerals.**

1	2	3	4	5	6
....	.....	.....	.....	....	.....
7	8	9	0		
....	.....	....	---		
Period	Comma				
.....	....				

## LESSON II.

**Translation.**

Translate the following words into Morse characters:

Abandon	Announce	Caution
Abide	Answer	Circumstances
Able	Anticipate	Couriers
Accept	Anxiety	Developed
Accident	Appear	Did
Accommodate	Appropriate	Disagree
Accompany	Arrange	Discharge
Accomplish	Arrival	Discouraged
Account	Arrive	Engagement
Acknowledge	Ask	Enough
Acquaint	Assertion	Excess
Act	Attempt	Exhausted
Action	Authorize	Expect
Actor	Average	Expense
Add	Avoid	Explain
Admit	Baggage	Fail
Advance	Bank	Feature
Advantage	Believe	Follow
Advertise	Benefit	Forward
Advise	Better	Gauge
Affect	Bill	Guarantee
Agent	Book	Hanger
Aid	Business	Heralds
Allow	Call	Injure
Amount	Cancel	Justice



[• •] [• • •] [— — —] [•] [• • •] [— —] [• •]  
 [• • • • •] [— — — —]  
                   [— — —] [•] [• • •] [— — —] [• •] [• •] [— —] [•] [• • •]  
 [• •] [• • • • •] [• • •]  
                   [— — —] [— •]  
 [• • • • • •] [• • • •] [• •] [— —] [— — •] [• •] [— —] [— —]  
 [•] [• —] [• • •] [—] [— • • •] [• •] [• • • •] [— •] [— • •]  
 [—] [• • •] [• —] [• •] [— —] [• • •]  
                   [• • •] [• •] [— — —]  
   [• • •] [• —] [— • •]

## LESSON IV.

### Manipulation.

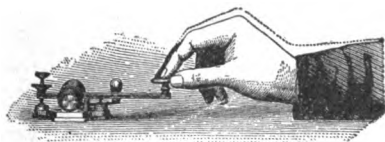

Manipulation, or sending, is the operation of forming dots and dashes, or telegraphic signals, on the instrument called the key.

### Position.

Place the first two fingers on the farther edge of the key-knob with the thumb under the edge; curve the first and second fingers so as to form the quarter section of a circle, partially close the third and fourth fingers, but do not curve them so as to

cramp them. Be careful that they do not touch the table. Rest the arm on the table with the elbow about two inches from the edge. Never allow the grasp to be rigid, but at the same time have it firm enough to work the key regardless of the spring which holds it up. Handle the key as you would handle a pen.

### **Movement.**

The motion is directly up and down, and is made principally at the wrist, although the fingers and hand must be used as a leverage, and all should work and move uniformly in the same direction. The downward movement of the key (closing the key) produces the dots and dashes, and the return of the key (allowing it to come up) produces the spaces and breaks.

The finger movement alone should be carefully avoided, as the fingers are used merely to hold the key. An instantaneous downward stroke of the key makes a dot [•], while the dash is made by holding the key down the length of time of three units of space, or a time equaling three dots. A long dash is the equivalent of two short dashes. The space, or break (the opening of the key) between the *elements* of a letter, equals one unit, while between *spaced letters* it equals two units, or between the *letters of a word*, three units.



## LESSON V.

### First Exercise.

Learn the movement by making dots slowly, making one each second, then two, three, and four each second. Then take up the dashes and make them in the same manner.

### Second Exercise. Dot Letters.

E      I      S      H      P      6  
 .      ..      ...      ....      .....      .....

### Third Exercise. Dash Letters.

T      M      5      L      0 (Cipher)  
 -      --      ---      -      -

### Fourth Exercise. Dot and Space Letters.

O      R      C      Y      Z      &  
 ..      ...      ...      ....      ....      ....

### Fifth Exercise. Dots and Dash Combinations.

N      D      B      8  
 --      ---      ----      -

4      V      U      A  
 ....      ....      ....      ..

**Sixth Exercise. Fractions.**

A dot or letter "E" substituting a hyphen between figures is transmitted 1e5. 1-5 2-7 9-15  
7-8 7-10 11-12.

**Seventh Exercise. The Dollar Mark.**

Transmit decimals by using the word "dot"  
thus : 32 dot 26 for 32.26, or SX 32 dot 26 for \$32.26.

**Eighth Exercise.**

Do not leave this exercise until you have completely mastered it. Drill upon it until perfection is attained. Work upon it until you are confident that the dots are not prolonged, that the spaces are uniform, and the dashes are all the correct length. Remember the dots and dashes (when not spaced) are close together, and the letters equal distance apart. When making a number of dots or dashes in succession, put them compactly together, so that intervals may not be mistaken for spaces. Repeat it backward as well as forward, and by selection, until every letter and numeral can be made at will correctly.

R	C	N	A	B	V
...	...	..	..	.....	.....
1	F	T	E	U	D
.....	.....	-	.	.....	.....
M	G	I	W	H	5
..	.....	..	.....	.....	.....

L	9	K	J	2	Period
—	—	—	—	—	—
Comma	O	3	P	Y	6
—	—	—	—	—	—
Z	Q	X	S	0 (Cipher)	
—	—	—	—	—	
4	7	\$	8	&	?
—	—	—	—	—	—

Ninth Exercise.

In transmitting numbers a short space usually is made instead of a comma between every three figures.

100	—	—		
1,000	—	—	—	
1,300	—	—	—	
15,765	—	—	—	—
20,234	—	—	—	—
4,657,234	—	—	—	—

## LESSON VI.

**Sending.**

Uniformity of space is highly essential for correct sending. This is applicable to the characters in letters, and spaces between letters and words.

All letters must be made perfectly. Do not add a dot to any letter, and do not fail to space where a space belongs. Make your *dash* a *dash* so plainly that it can not be mistaken for a dot.

**Words of Unusual Spaces.**

Due caution should be exercised in transmitting words which contain either all dot letters or a number of them together.

The spaces should be larger than usual between the letters in the following words, as well as a great many words of a similar character. Be sure to make them slowly, carefully, and distinctly.

Error	Erie
. . . . .	. . . . .
Seen	Choice
. . . . .	. . . . .
Piece	Voice
. . . . .	. . . . .

A decided distinction should also be made whenever the letter "t" follows the letter "l," or *vice versa*, as in the words :

Little

— . . — — — .

Title

— . . — — — .

Lotta

— . . — — — .

Bottle

— . . . . — — — — — .

Cottage

. . . . — — — — .

Lottery

— . . — — — . . . . .

Alternate

. . — — — . . . . — — — .

Altitude

. . — — — . . — — — .

Lattice

— . . — — — . . . . .

The student may take such words as he chooses for practice after he can write the words in this exercise. The best results can be obtained by arranging a similar series for practice.

Bake	Kate
.....	.....
Cake	Chain
.....	.....
Box	Decide
.....	.....
Exchange	
.....	
January	
.....	
Game	Frost
.....	.....
Humane	
.....	
Knight	
.....	
Maintain	
.....	
Liable	Insane
.....	.....



## LESSON VII.

**Punctuation.**

Having familiarized himself with the alphabet and numerals, the operator will then find it to his advantage to apply himself to memorizing the punctuation marks.

Apostrophe .....	'	Qx.
Brackets .....	[ ]	Bx.
Capital Letter .....		Cx.
Colon .....	:	Ko.
Colon-Dash .....	:—	Kx.
Comma .....	,	Aa.
Dash .....	—	Dx.
Dollar Mark .....	\$	Sx.
Exclamation .....	!	Mn.
Hyphen .....	-	Hx.
Interrogation .....	?	Tq.
Paragraph .....	¶	Mm.
Pence .....	d	D.
Period .....	.	Ud.
Per cent. ....	%	Pc.
Pound Sterling .....	£	Px.
Semicolon .....	;	Si.
Shilling Mark .....	s	Ut.

NOTE. — Punctuation in transmitting is more different than would appear in print, and to the operator, certain punctuation marks convey as much meaning as the expression of the face and tone of the voice, when two persons are talking.



## Explanation of Simple Punctuation.

Were we to send punctuation marks as they are printed, it would be a difficult matter to avoid confounding them with words to which they are related at times. Take for example the word: To-day's. If we desire to capitalize it and insert the hyphen and apostrophe, we would send it as follows: Cx to hx day qx s—. This example explains itself. There must be some distinction between the letters of the word and the letters forming the punctuation marks. This is obviated by sending the letters in the punctuation marks at *twice* the speed of the others. When they contain two letters they are invariably *sent as close together as one letter*.

The *Apostrophe*, *Brackets*, *Capital Letter*, *Exclamation*, *Pence*, *Per cent*, *Pound Sterling*, and *Shilling Mark* are used in press work more than anywhere else, but at times all operators will need these marks even at small stations.

The *Colon*, *Colon-Dash*, *Semicolon*, *Hyphen*, *Dash*, and *Paragraph* are used constantly to-day by the commercial companies, and must eventually be more commonly adopted by the railroads. The public has discovered that punctuation marks are sent in their telegrams, and the next few years will find the different companies employing those alone who can punctuate, and will insist upon their use just as the newspapers do among their employes.

The *Comma* is used perhaps more than any other punctuation mark. It is often used in place

of a period [.] and conveys several meanings, according to the position in which it stands. For example, if after the three or four lines in the address of the message, or where a message contains several addresses, and the comma [Aa] is used, it would signify to *drop another line*, as per example :

John Brown [,]  
 Traveling Salesman [,]  
 Deere & Co [,]  
 Chariton Ia [.]

The *Period* [.]—While the period is used on the “received message” in many places, the receiving operator takes it upon himself to place it where it belongs ; while the sending operator will only send it, perhaps, immediately after the destination in his message, just preceding the body of the message proper.

The *Dollar Mark* [\$] is used and counted as one word whenever it appears in any message or cablegram, and is sent just preceding the numerals, as per example : Sx 14. for \$14.

The *Interrogation* [?], or question mark, as it is often called, is one of the most *useful little* things in the telegraphic world. It is used in a great many different ways. If an operator starts to make a word and makes a mistake, he sends an interrogation mark, then repeats the word, just the same as you would correct yourself in a speech by saying “*I mean.*” Again, where the word used is not exactly the proper word for the place in the operator’s mind, he calls the attention of the other operator by making an interrogation mark, and

repeating it, which would seemingly be in words spoken: "There is a question in my mind regarding that word, but *that is my copy.*"

Again, it is used, if sent interruptively in a message, the same as the word: "what?" meaning that the operator is not getting what is coming.

If, however, it is sent in the body of a message after a sentence asking a question, it is used in its proper sense. When used this way, operators always allow a little space or interval of time immediately afterwards.

The *Paragraph* [¶] is used in press work, and in sending poetry, or whenever the *copy requires* a new paragraph.

### Compound Punctuation Points.

*Parentheses* ( )—PN stands for the first ( and PY for the second ). The old method of using PN for both the first and second marks has been almost eliminated, owing to the fact that it confounded the receiving operator where the parentheses occurred several times in the same message. The same rule applies to quotations and underlining.

*Quotations* " " — QN stands for the first " and QJ for the second ". Quotation marks within a quotation are the same as an apostrophe Qx ' Example:

He said: "Her reply was 'No' to each question," or, He said: Qn Her reply was Qx No Qx to each question Qj.

*Underline.* — Ux stands for the first and Uj for the second. Where Ux announces the underline,

you would continue to underline until you received Uj. Example:

We must insist upon an Ux immediate settlement Uj. Wire answer.

Copy: We must insist upon an immediate settlement. Wire answer.

*Decimals* are sent by inserting the word "dot" thus: 1 dot 25 for 1.25; 95 dot 23 for 95.23; Sx 1 dot 23 for \$1.23.

*Fractions* are sent by inserting the letter "e" between the numerator and the denominator, thus 1-2 would be 1e2.

*Hundred, Thousand, and Million* contain so many ciphers which, quickly transmitted, make combination errors, as, 1,000 sounds like 15, since three ciphers or dashes make five [5]. For this reason, in press work they use "hnd" for hundred, "tnd" for thousand, and "myn" for million. Example:

100 [1 hnd]; 1,000 [1 tnd]; 1,000,000 [1 myn].

In messages, as a precaution, the operator sends it 1 0 0, then makes an interrogation mark and repeats it 1 hnd, then another interrogation mark and sends it 1 0 0 again. The same is applicable to the sending of thousand and million.

## LESSON VIII.

### Receiving.

Having memorized the letters and characters, to begin reading by sound it is necessary for another person to manipulate the key or to use an automatic

transmitter. The practice should commence by receiving letters and copying them.

The back stroke, upward movement of the lever, is as necessary to reading as the down stroke, and must be distinguished from the other, for without it the duration or length of dashes could not be determined. The back stroke is dull, and will not confuse the student when he puts his mind on the down stroke for his dots and dashes, and takes the upward, or back stroke, for his breaks and spaces.

The movement of the lever to and from the magnet between the adjusting screws and striking against them, produces the sounds; an arch or bridge is provided upon which the downward stroke of the lever takes effect. The space between the metallic and wooden bases forms a sounding box. When screwed down to a table, the acoustic vibrations are thus communicated to the table, which acts as a sounding board, thence to the ear. It should be remembered that there is no change in the tone of a sounder, the letters being determined solely by the time, or times, the lever is down.

If a letter or word is missed, open the key and repeat the last few letters or the last word received; never repeat simply one letter, or say "repeat," but give them "*what you got,*" and tell them to start there. Don't try to copy letter for letter and don't get too far behind, but get it down, write down all you get; the attention must be divided and requires exercise of the memory. The more you can copy behind, the greater your speed will be in receiving. With unwearied application you will soon be able

to copy a word or two behind. Have some one dictate fifty or a hundred words to you, just a trifle faster than you can write each day, and copying behind on the wire will soon be an easy matter.

Read the daily papers, become acquainted with the phrases for every line of business, study the form of market reports, and interest yourself in congressional news. Study the names of different towns so you can spell them offhand, and you will have part of the battle won.

The following words will be readily recognized if practiced daily: OF, THE, THAT, AND, WAS, WILL, IT, AT, NOW, PAID, WHEN, WHY, THEY, YES, and NO.

The word "the" sent carelessly sounds like "be," and the word "at" sounds like the letter "W."

The student will discover many words containing conflicting characters, and as these words will seldom come to the ear perfectly it is necessary for him to work hard and find where the conflicts lie in each and overcome them to avoid them in the future.

The following are some of the most difficult words: EYE, ICE, IRON, CHIEF, HERE, THERE, THREE, and other words containing the letters "e, i, r, and c," and similar dot and dot-spaced letters.

Among the numerous errors that have from time to time been made are "Ices" for "Yes"; "Hog" for "Home"; "Cog" for "Come"; "&q" for "Esq.,"; "Jagill & Pie" for "J. A. Gallespie."

These errors generally result in controversy and costly litigation.

## LESSON IX.

**Penmanship.**

## Rule 1.—

In telegraphic business, good, legible business penmanship, based upon telegraphers' experience of modern times, is absolutely necessary, instead of ornamental styles with graceful shades. Make your letters in writing of the shortest length practical, and without curves where it is possible to retain the contour of letters without them. Write your letters very plainly, and numerical figures distinctly, and it will be a blessing and not a curse to all who have anything to do with your writing.

## Rule 2.—

No words should be joined together.

## Rule 3.—

Capital letters should not be joined.

## Rule 4.—

The capital "T" should never be looped at the top, as, for instance, seventy is liable to be taken for twenty, or *vice versa*.

## Rule 5.—

A capital "H" should never be made to be mistaken for an "A" or other combination.

## Rule 6.—

Cross all "t's" with a single horizontal line at the top.

## Rule 7.—

The capital "I" should always be made above the line, while "J" should extend below, otherwise they can not be distinguished with certainty.

## Rule 8.—

The small “s” should never be made with the loop below the line, as it is liable to be mistaken for “p” or “f.”

## Rule 9.—

Make the letter “Q” after the fashion of the Roman capital letter, thus “Q,” otherwise it can not be distinguished from the figure 2.

**Specimen of Telegraphers' Script.**

A B C D E F G H I J K

L M N O P Q R S T U V

————— W X Y Z —————

a b c d e f g h i j k l m n o p q r s

t u v w x y z            1 2 3 4 5 6 7 8 9 0

GC—Cand—E—Exa—Eng—Cond—

Paids—Collect—DH—Dely—Chge—

Come—immediate—shipped—dis—



## PART III.

### LESSON I.

#### Commercial Business.

##### Rule 26.—*Office Calls.*

An operator when calling an office will sign his own office call at short intervals, and will also sign it in answering calls.

Example of "DX" calling "DS": DS. DS. DS. DX. DS. DS. DS. DS. DX. DS. DS. DS. DX.

Example of "DS" answering call: I. I. DS.

##### Rule 27.—*Sending.*

The sending operator will regulate the transmission to suit the ability of the receiving operator.

##### Rule 28.—*Order of Transmission.*

In sending a message the operator will observe the following order of transmission:

1. The number of the message and his office call.
2. The operator's personal sign. [His own.]
3. The check of the message.
4. The place from and the date of the message.
5. The address of the message.
6. The body and signature of the message.

##### Rule 29.—*The Transmission of Checks.*

All the words and figures in the check will be transmitted except:

1. The amount of tolls, in case of a prepaid message to a "this" line office.

FORM NO. 260.

**THE WESTERN UNION TELEGRAPH COMPANY.**

**INCORPORATED**  
**21,000 OFFICES IN AMERICA. CABLE SERVICE TO ALL THE WORLD.**

**ROBERT C. CLOWRY, PRESIDENT AND GENERAL MANAGER.**

Receiver's No.

Time Filed

Check

150 | 10 AM | 3 Paid

**SEND** the following message subject to the terms on back hereof, which are hereby agreed to.  
*New York July 27-02*

*John Brown*  
*Chicago, Ill.*  
*Come home immediately*

*Mother*

**READ THE NOTICE AND AGREEMENT ON BACK.**

NOTE.—Each message for transmission will be written upon the above form provided by the companies for that purpose, or be attached to such a form.

### **Receiver's Number.**

This refers to whomever accepts the message from the customer. The operator in a small station would place his "wire sign" in this place. In the larger commercial offices, he would write his sign and also number it.

### **Time Filed.**

This refers to the time the message was *offered to the sending office* for transmission, and has no reference to the time of transmission by wire, which is noted across the face of the message at the time it is sent.

### **Check.**

The number of words counted and charged for, viz.:

All words, figures, and letters in the body of the message.

All signatures, when there are more than one, except the last.

All words in excess of two in a title after the last or only signature.

All words after the signature which are not title words; and, in the check, the words, "Deliver and report charges," "Delivery charges guaranteed."

**THE WESTERN UNION TELEGRAPH COMPANY.**

**INCORPORATED  
21,000 OFFICES IN AMERICA. CABLE SERVICE TO ALL THE WORLD.**

This Company TRANSMITS and DELIVERS messages only on conditions limiting its liability, which have been asserted to by the sender of the following message. Errors can be charged against only by repeating a message back to the sending station for comparison, and the Company will not hold itself liable for errors or delays in transmission or delivery of Unrepeated Messages, beyond the amount of tolls paid thereon, nor in any case where the claim is not presented in writing within sixty days after the message is filed with the Company for transmission.  
This is an UNREPEATED MESSAGE, and is delivered by request of the sender, under the conditions named above.

**THOS. T. ECKERT, President and General Manager.**

NO. 100 SENT BY REC'D BY CHECK

*Dr. R. M. O. Baird*

**RECEIVED** at 210 Adam St. - July 29 1902

Dated

*New York N.Y. 29 July 1902  
To John B. Newell Chicago, Ills*

*Come here immediately*

*Mather*

*10:20 am*

NOTE.—In receiving a message we can expect the following order of transmission from the sending operator:

1. The office call or sign of office sending the message. (Only the larger cities number the messages with each other.)
2. The sending operator's personal signal.
3. The check, which contains the number of words, and states whether the charges are paid or to be collected.
4. The place from and the date of the message.
5. The "to," or address of the message; this contains the name of party or parties the message is for, their street or building address, and the final destination of a message.
6. The body of the message.
7. The signature of the message.

### Messages to be Copied.

Each message for delivery will be copied and enclosed in the proper envelope which will be carefully sealed and plainly addressed.

In all the following messages, all combinations of letters and characters enclosed in brackets [ ] are sent by the sending operator, while those in quotations [ " " ] are written by the receiving operator, but are not *sent* by the *sending* operator.

The signals "Hr," "Ahr," or "Añr" are invariably used to announce the beginning of a message. To one in the business, it sounds the same as some one saying "Here," "And here," or "Another."

FORM NO. 1.

[*Des Moines* Received Copy.]**Commercial Telegraph Company,**

This Company **Transmits and Delivers** messages only on conditions which have been assented to by the sender of the following message.  
 Errors can be guarded against only by repeating a message back to the sending station for comparison, and the Company will not hold itself liable for errors or delays in transmission or delivery of **Unrepeated Messages.**  
 This is a: **Unrepeated Message**, and is delivered by request of the sender under the conditions named above

[Hr city no] 36 CH PZ "MK" [Ck] 9 Paid.

[Fm] *Chicago Ills* "Feb" 21 "th 1902"[To] *E. I. Barnett & Co,**916 South 3rd St,**Des Moines Iowa.**Why do you refuse payment on our draft answer.*[Sig] *Bartholomew & Co.*

"3:10 P. M."

“City” indicates the message is to be delivered at the point it is being received. Where offices handle considerable business with each other, they number each message as a precaution against losing a message.

“CH” is the call for Chicago. It takes too much time to spell out the full name of a city, so each is given one letter or two letters which are known as the CALL. Oftentimes two cities have the same call, but no two cities on the same circuit have the same call. These signals or calls are made use of in arresting the attention of the different stations. For instance the call for Chicago is “CH,” Des Moines “DS”; when Chicago first desires communication with Des Moines, he repeats the latter’s call on the line until answered. It is proper for Chicago to sign his office call every third or fourth call to notify Des Moines who is calling. If Des Moines hears the call he opens the key and acknowledges it by saying “I” “I,” signing his office call “DS,” and then, and not until then, does Chicago proceed with his business. The same process is applicable between all other offices. “PZ” is the sending operator’s personal signal in the preceding message, and “MK” the receiving operator’s personal signal.

In all the following messages, regardless of whose signal it is, the one following the *office call* is always the *sending* operator’s signal, and the one just preceding the “Ck” is the *receiving* operator’s signal or “sine,” which is never sent on the wire when he is receiving, and

only sent when he is *sending*, and then only by *himself*.

“Ck” indicates the *check* which gives the number of words subject to tariff, and tells whether a message is paid, collect, or free; if free, explaining why. The check immediately precedes the “FM” or date, and aids in preventing errors and omissions. “FM,” or date, is the originating point of a message and the date, but it is the duty of the receiving operator to always add to this the month and year.

“To” is the address, and all messages must bear one clear and sufficient address to a single person or firm, together with street, number, and place of its destination, *which will not be charged for*.

The “period” [.]—the beginning of the body of the message. The body is embraced between the period [.] and “signature” [sig.] The word “sig” enables the receiving operator to place the signature in the proper place. Under the signature the “time” received should be placed on all messages.



FORM NO. 1.

[Chicago's Received Copy.]

## Commercial Telegraph Company,

This Company Transmits and Delivers messages only on conditions which have been assented to by the sender of the following message.  
 Errors can be guarded against only by repeating a message back to the sending station for comparison, and the Company will not hold itself liable for errors or delays in transmission or delivery of Unrepeated Messages.  
 This is an Unrepeated Message, and is delivered by request of the sender under the conditions named above.

[Hr city no] 78 DS MK "PZ" [CK] 11 Collect.

[Fm] Des Moines Iowa "Feb" 21 "th" 1902

[To] Bartholomew & Co,

Chicago Ills.

[.] Your draft calls for ten dollars over bill of lading.

[Sig] E. L. Barnett & Co.

"4.00 P.M."

In collect messages the word "collect" is *counted but not charged for*, to aid in preventing errors.

**Rule 30.—*Acknowledgment of Receipt.***

No message will be regarded as transmitted until acknowledged by the usual signal; but if a number of messages are sent in succession, the acknowledgment of the last will be regarded as an acknowledgment for all. Example: "Ok, PZ."

**Explanation of Two Different "Received" Copies.**

In the foregoing examples we have two *received* copies. The first is the copy as it would appear when RECEIVED AT DES MOINES from Chicago. On the first line you will note that "CH" is the call of the office Des Moines received the message from, and "PZ" the signal of the operator sending it to Des Moines, while "MK" is the signal of the operator at Des Moines receiving it from Chicago. The receiving operator always places his own signal after the operator sending the message has sent the office call, and his own sign at the sending office.

On the next message we have "DS" instead of "CH" because this is the copy as the operator at Chicago received it. Following "DS" we have "MK" or the Des Moines sending operator's signal, and following this the operator at Chicago has placed his own signal.

The object in having the signals placed in this manner, is to keep a record of the operator handling the various messages, in case it becomes necessary to have a statement about the message at any time in the future owing to a mistake or error of some kind.

Rule 31.—*Order in which Messages are to be Received.*

In receiving a message the operator will write his personal sign in the space headed "Rec'd By." He will write the name of his office immediately after and on the line "Received at," and the "time" of receipt also on the same line or immediately over the check, or below the signature. The acknowledgment of receipt will be made by transmitting the signal: O. K., and the receiving operator's personal sign and office call.

Rule 32.—*Verification of Check.*

The receiving operator must ALWAYS COUNT THE WORDS, verify the check, and otherwise satisfy himself that the message is correct before allowing it to leave his hands.

### **Make Up.**

Make up twenty-five RECEIVED COPY messages, using different names, checks, and towns in each.

### **How to Break.**

Breaking is to stop the sending operator when you miss a letter or word. You should say "BK" and repeat the last letter or word you received. The key is before you for the purpose of breaking as well as sending, and you should break a dozen times rather than guess at one letter.

### **Breaking.**

When breaking in a message, in case you miss in receiving the number, say "Ga No" [Go ahead

number]; if you miss operator's sign say "Wo" [Who]; check, say "Ck"; originating point say "Fm" [From]; state say "State"; date say "Date"; name in address say "Ga To"; street number say "Ga ," [Comma]; beginning in body, say [.] "Period"; in middle of body, repeat the last word you received; in signature say "Ga sig."

### How to Copy.

On plain words endeavor at least to copy one or two words behind. On cipher messages, copy with the sender.

Five words to a line, when writing with pen or pencil, and ten words to a line, with several spaces after the first five, while copying with the typewriter, will enable you to verify the check at all times.

## LESSON III.

### Example of Commercial Abbreviations.

Abbreviations in conversation over a wire are to save time and are used by all operators, more or less, except in commercial messages.

Cn u hndle 1 fo Soo City? — Can you handle one for Sioux City?

Tt ck is off only 9 wds. — That *check* is off, only nine words.

Wts tt 3rd bdy wd? — What is that third body word?

Cnt u mk tt 4th bdy wd Beau instd o Bean? —

Can't you make that fourth body word Beau instead of Bean?

U tr—You there? Wr u bn all am?—Where you been all morning?

Wo—Who? [Meaning your sign.]

Wt—What?

Wt u sine & wt ur cl?—What do you sign and what is your call?

Wt ws last tt u got?—What was the last that you got? [Give last word or number.]

Hw mny ex wds in tt msg?—How many extra words in that message?

Hw do u cnt art?—How do you count alright?

Bk mi locals off. — Break, my locals off. [Referring to sounder when battery is weak.]

Hrs combn 3 trus 2 ci abt tnd wds sa wn. — Here is a combination [Special] three through copies, two city copies, about one thousand words say when [Ready].

Bk 1 min gt book md fo em. — Break one minute get book made for them.

Hrs cple reds. — Here is a couple of reds. [Meaning night messages.]

Hw u gt me, is ts crying art to u? — How do you get me, is this carrying alright to you?

Cm dwn on tt key its too lite. — Come down on that key it is too light.

Sa adjst tt inst es kp off hr ur bkg me. — Say adjust that instrument and keep off here, you are breaking me.

1 min pls I gt a 23 let me gt it off so I cn go hm.

—One minute please I got a death message let me get it off so I can go home.

O. K. ga bt hy I am piled up myself. — O. K. go ahead but hurry I am piled up myself. — [Piled, meaning a large number of messages on hand to send.]

### Wire Testing Abbreviations.

U gt 9 open tr? — You got nine open there?

Pt Pac 9 e to 12 w sa wn. — Put Pacific 9 east to 12 west say when. [To PUT is to connect in telegraphy.]

Do u hr me on 16 s? — Do you hear me on 16 south?

Gnd 7 n es try me tr. — Ground 7 north and try me there.

Tk tt gnd off o 7 n nw. — Take that ground off of 7 north now.

Ix off now. — It is off now

Wh wa is 65 open to u? — Which way is 65 open to you?

E—East.

W—West.

N—North.

S—South.

Dnt gt ckt etr wa. — Don't get circuit either way.

Tn it mst b in ur ofs lk at ur cntns. — Then it must be in your office look at your connections.

## LESSON IV.

**Service and Office Messages.**

“Svc” or “Ofs” —Messages pertaining to messages which have been sent, or received, respecting their delivery, collections or delay. [Rule 23.]

Service messages between the employes of the company will be limited to matters of an urgent nature. The mails will be used in all cases when the service will not suffer by delay.

Service messages will not be sent free for the information of customers, nor to correct their errors.

**First Series of Service or Office Messages.**

[A] — *Asking for address*

*To Chicago Ills.*

*G. B. A. or cant 92 yours today Jones sgd Smith Party unknown cant find. Collect there.*

*Des Moines Iowa Feb 21 1902.*

---

[B] — *Giving Address*

*To Des Moines Iowa.*

*S. Y. S. ours Feby 21st Jones sgd Smith Try care of Standard Oil Co Advise delivery.*

*Chicago Ills Feb 21st 1902.*

---

[C] — *Announcing delivery*

*To Chicago Ills.*

*D. F. S. have deld o. k. yours 21st Jones sgd Smith.*

*Des Moines Iowa Feb 22 1902.*

A — G. B. A. used for Give Better Address, or  
G. S. A., Give *Some* Address.

B — S. Y. S. used for See Your Service.

C — D. F. S. used for Disregard Former Service.  
92 used for word Deliver.

[A]

Of the first series [A] is a message you would send in case you received a message and could not deliver it. This message should not be sent, however, until you have made inquiries, tried hotels and post office, and made every possible effort to locate party or parties. In case the message was paid you would omit the words "Collect there."

[B]

In case you had sent a message and received a service like [A] asking for better address, and the sender could give some inkling as to a possible place to deliver message, you would send a message similar to service [B]

[C]

After receiving some address, in case you could deliver message, you would send a service notifying them to disregard former service, but in case you could not deliver it you would send the following service:

*To Chicago Ills.*

*S. Y. S. yours 21st Jones sgd Smith still undeld,  
party unknown at Standard Oil Co's office.*

[Sig] *Des Moines Iowa 22nd.*

Make up a common message and follow it with service messages similar to examples above.



Postal Commercial Company.

Message	Sent By	Recd By	Checked
1000	go	pl	9 Paid
Dated Anita June 27		Chicago Ill	
to Parrott Umbrella Co		Chicago Ill	
Chicago Ill			
Send twenty cables umbrellas and			
twenty five cables parrots.			
James Brokers Co.			

Received at  
 Chicago Ill  
 (WHERE ANY REPLY SHOULD BE SENT.)  
 C.A.H. 27  
 1902

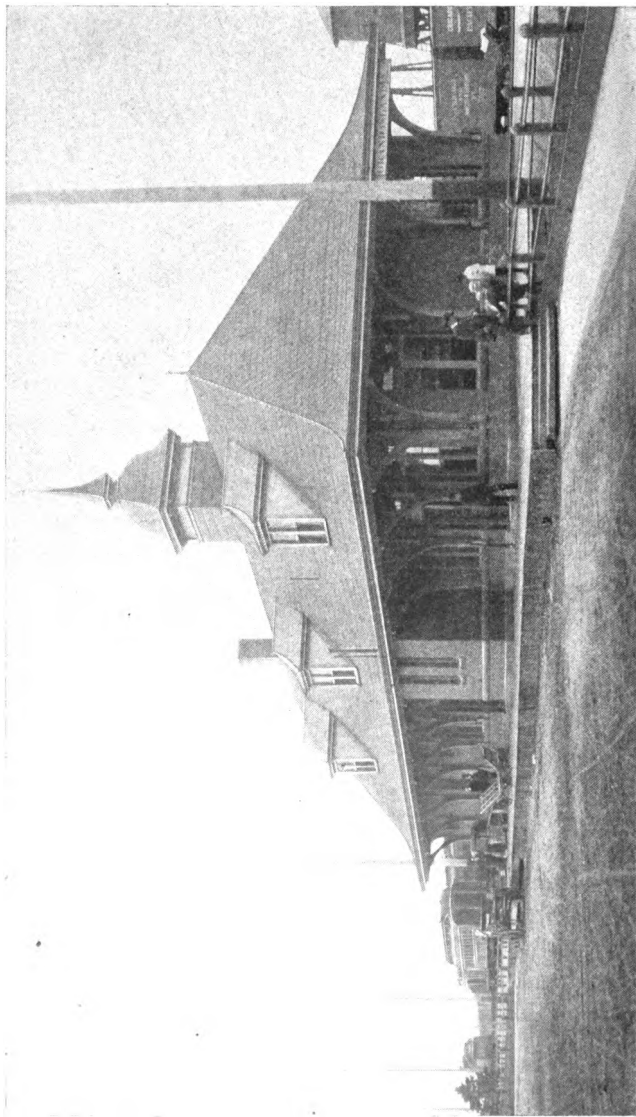

A modern way station. A pleasant place for an operator.

# PART IV.

## Beginning Railway Telegraphy.

### LESSON I.

#### General Instructions.

*In case of doubt adopt the safe course.*

To enter or remain in the service is an assurance of willingness to obey the rules.

The train order manifold must be made up and at all times in readiness to take orders, so the dispatcher will not be delayed by your taking time to fix it when he calls for orders.

Watch all trains and notify your dispatcher in case they are detained at your station longer than usual, informing him what they are doing, how much longer they will be there, and ask for advice.

To leave your office, it is necessary for you to notify the dispatcher and receive his permission to leave.

Where day and night operators are employed, one can not leave the station until relieved by the other. Each must remain on duty until the other arrives. Operators must not change off without the permission of the superintendent or chief dispatcher.

Always note the exact arrival or departure, or both, of trains regardless of the time that is placed

on the register by conductors. Inform yourself in regard to approaching trains, and be prepared to furnish information promptly to such persons as should receive it.

Read all messages *carefully* before sending to prevent delay in sending. No message will be transmitted from dictation, or otherwise than from legible copy. When difficult words occur in messages, transmission must be slow and distinct. If any delay in the transmission of messages occurs, note on back of the message the cause of the same.

Contention for circuit, and profane or obscene language upon the wires is forbidden. When the circuit is broken by the *proper* signal, it should be done at the end of the message, and the sending office allowed to receive its "O. K." before circuit is broken. Drumming or fooling on the wire is positively forbidden.

Operators must keep their tables and instruments clean, must know that all connections, binding posts, screws, etc., are firmly connected, and that wires or crossings over buildings, etc., about their stations are clear and safe.

Whenever a train order is of such length that it can not be written plainly and clearly without crowding on order blank, operator should note on the bottom of blank where order is written, "continued on second sheet," and copy balance on second sheet, noting on second sheet, "continued from first sheet." No part of a train order proper should be written on any part of the blank except the place provided.

## GENERAL INFORMATION.

Send this lesson on your wire.

### Number Schedules.

Car or engine numbers will not indicate the number of a scheduled train. TRAIN NUMBERS ARE IN FACT USUALLY IMAGINARY. They are in fact designated only on "Time Schedule."

### Numbering.

ALL EVEN numbers are EAST-BOUND.

ALL ODD numbers are WEST-BOUND.

Excepting—EXTRAS.

Extras are numbered by their engine numbers and may run "Odd" or "Even" in either direction.

### "3" or "OS"-ing.

Operators will promptly record and report to the superintendent the departure of all trains and the direction in which EXTRAS are moving. They will RECORD the time of arrival of trains and report them when so directed. This is called "3" or "OS"-ing trains.

### How and When to "OS" a Train.

After the markers have passed three hundred feet or more, trains should be reported with either the signal "3" or "OS." For instance, in reporting No. 5 out of Luzerne, the following form would be used:

"OS" "OS" "Z" No. 5 "A" [or "AR"] 515

“*DE*” [or “*D*”] 516 “*Z*” or “3” “3” “*Z*”  
 No. 5 “*A*” 515 “*De*” 516 “*Z*.”

“3” or “*OS*” — *Is a signal for “Order Sheet” or “On Sheet.”*

*No. 5, number of the train.*

“*A*” [or “*AR*”] — *Arrived.*

“*De*” [or “*D*”] — *Departed.*

“515” — *The time.*

“*Z*” — *The office call of station reporting the train to the Supt. In case of train not stopping, it would be reported:*

“*No. 5 by 516 Z.*”

### **Day Operator to be Called.**

Should a night train be held at a telegraph station where there is no night operator, the conductor will call the day operator into the office to get orders for his train.

### **Rules for Movement of Trains by Orders.**

For movement not provided for by the timetable, train orders will be issued by authority and over the signature of the Superintendent or Chief Train Dispatcher. They must contain neither information nor instructions not essential to such movements. They must be brief and clear; in the prescribed form when applicable.

Each train order must be given in the same words to all persons or trains addressed.

Train orders will be numbered consecutively each day, beginning at midnight.

Train orders must be addressed to those who are

to execute them, naming the place at which each is to receive his copy. Those for a train must be addressed to Conductor and Engineman, and also to anyone who acts as pilot. A copy for each person addressed must be furnished by the operator.

Each train order must be written in full in a book provided for that purpose at the office of the Chief Train Dispatcher, and with it recorded the names of those who have signed for the order, the time and signals which show when and from what offices the order was repeated, and the responses transmitted, and the train dispatcher's initials. These records must be made at once, and never from memory or memoranda.

When an order is to be transmitted, the signal "19" or "31" meaning "train order" will be given to each office addressed, followed by the word "copy" and a figure indicating the number of copies to be made, if more or less than three—thus "19 copy 3" or "31 copy 5."

A train order to be sent to two or more offices must be transmitted simultaneously to as many of them affected as practicable. The several addresses must be in the order of the superiority of trains, each office taking its proper address. When not sent simultaneously to all, the order must be sent first to the train of superior right of track.

When a meeting point is to be made between two trains at a certain point, the order, when practicable, should be sent to said trains to stations at either side of the actual meeting point, also to the

operator at the actual meeting point, if a telegraph office.

Operators receiving train orders must write them in manifold during transmission, and if they can not at one writing make the requisite number of copies, must trace others from the copies first made. Operators required to make new or additional copies of an order will, in every instance, repeat those copies the same as the original order.

When an order has been transmitted, preceded by the proper signal, operators must repeat it at once from the manifold copy in the succession in which the several offices have been addressed, each operator observing whether the others repeat correctly.

After a "19" order has been repeated correctly by the operators required at the time to repeat it, the response "complete" and the "time" with dispatcher's initials will then be given by the train dispatcher. Each operator receiving response will then write on each copy the word "complete," the time, and his last name in full, and will then deliver a copy to each person included in the address, except the engineman, and each must read his copy aloud to the operator.

Orders once in effect continue so until fulfilled, superseded, or annulled.

When an operator receives the signal "19" or "31" he must immediately display red, and this signal must not be changed to clear until the object for which it is displayed has been accomplished.

While red is displayed all trains must come



to a full stop, and any train thus stopped must not proceed without receiving an order addressed to such train, or a clearance card on a specified form stating over the operator's signature that he has no orders for it.

## LESSON II.

### **Sending Orders on the Wire.**

In *your* practice, to send an order, you begin :

ORDER NO.....

[ Stating number ] and follow this with the name of the dispatcher's office, which you announce "FM" [ meaning From ]. The letters "FM" are not written on the order, and are used to announce that the dispatcher's office follows, so you know what to write next. Example :

[ fm ] "Montpelier, O 3."

The next line "For.....to.....of....." comes over the wire somewhat different than appears in print. Dispatchers as a rule abbreviate everything they possibly can where it is in print on the form, and in the way of addressing an order, simply say :

To WH C & E 1st & 2nd 69 WH.

"WH" being the office call and abbreviation for Whittaker in this case, the operator writes it out in full immediately after the word "For....." on his order. The word "To" is likewise printed on the FORM, as is also "OF.....," so the operator's copy reads :

For Whittaker. To C & E OF 1st & 2nd 69.

After this the dispatcher makes a period [ . ] and begins the body of the order. The PERIOD [ . ] is used in a manner like [ fm ] announces ; the body or text, follows.

The way the dispatchers generally send an order will be found in the following example :

[ Copy 3 ] ORDER No 123 TO WH C & E 1st & 2nd 69 WH.

[ . ] No eighty eight 88 eng 210 will wait at Auburn until seven fifty five 755 pm and at Willis until eight five 805 pm for first 1st and second 2nd 69 engs 183 & 65 [ sig ] J J S.

Letters in brackets [ ] received but not copied.

There MUST BE NO erasures, alterations, or interlineations.

### Repeating.

In repeating the order you will use this form:

The Order Number	.... "No" ....
Train Addressed	.... C & E....
Your Own Office Call	.... WH .....
Period	.... [ . ] .....
Body of the Order	.....
Dsprs Initials	.... J J S.....
Your Own Sign	.....

The dispatcher would then give you "complete" and *time* which you would write on line "MADE.....AT....." Example:

MADE "Complete" AT "8" pm.

The "Time Received" and "Received By," you fill in yourself.

This form is termed a "19" order.



with the telegraph **MUST ATTEND** to those of the **TELEGRAPH FIRST**.

**THE GREATEST CARE MUST BE EXERCISED IN SENDING OR RECEIVING ORDERS REGARDING THE MOVEMENTS OF TRAINS BY TELEGRAPH.**

The following signs and abbreviations are used in train orders :

C & E .... For Conductor and Engineer.

C and E-- Same.

O K ..... For Correct.

Mins..... Minutes.

Junc..... For Junction.

Frt..... Freight.

Spl..... Special.

Exa..... Extra.

No ..... Number.

Eng..... For Engine.

Sec..... For Section.

Opr ..... For Operator.

### **Copies.**

The operator will make a copy for each Conductor and Engineman of trains addressed, and one for office record which bears his name.

## **LESSON IV.**

### **Numeral Signals.**

1. Wait a minute.
3. Order sheet. (Same as O S)

4. Where shall I go ahead ?
5. Have you anything for me ?
8. Close circuit you are breaking.
9. To clear line for train orders and for operators to ask for orders.
12. How do you understand ?
13. I or we, understand.
18. What is the trouble ?
19. Train order.
23. Accident or death message.
25. Busy on other wires.
29. Train orders.
30. Finis, the end.
31. Train orders.
33. Answer paid for.
73. Accept my compliments.
134. Who is at the key ?

These signals are used to abbreviate and save time. Some convey special information while others serve to furnish an answer. For example, if you were receiving a message and were interrupted to such an extent that you found it necessary to stop you would say, "1." meaning, wait a minute.

If you were expecting a message from another town, or for some reason believed another town had business for you, you will call him on the wire and send the signal "5," which would be the same as asking, "Have you anything for me?"

Again, if you were sending a long message and forgot just which word you sent last, you would send the signal "4," meaning, "Where shall I go

ahead?" During inclement weather when the wires are more or less affected, and as is often the case, too many try to work the same wire simultaneously, the operator having the right to the wire will use "8," meaning, "Close the circuit, you are breaking."

"23" is used in calling another office when you have a death message, being sent at intervals over the wire to attract attention.

Where you find it impossible to answer some office calling you, and wish to inform him that you hear him calling you, if you were busy at something else, you would send "25," meaning, "I am busy."

"33" is used on messages where the sender is desirous of paying for any reply to his own message. It is placed immediately after the check for the benefit of the operator receiving it. Example: "10 Paid and 33."

The signals "9," "19," "29," and "31" are used to announce train orders.

### "X"

The terms "X," "X'ing" or "X'd." — "ACKNOWLEDGING" an order.

The form used: Order No.—To C & E of train addressed, — the letter "X" — and your initials or wire sign, and office call.

Example: [A] Order No 33 To C & E 45 X  
F. L. M. Gd.

Example: [B] Order No 54 To C and E 4 X  
MK. Gd.

NOTE.— Example [A] used generally on 19 and 31 orders and the "X" is followed with the full

initials; while in example [B] the "X" is followed simply with the wire sign and office call.

Where orders are addressed to a superior and an inferior train and it is desirable to have the inferior train receive its orders before these orders are completed and delivered to the train of superior right, it becomes necessary for the dispatcher to receive an ACKNOWLEDGMENT from the operator holding orders to the train of superior rights before allowing delivery to be made to the train of inferior rights.

"X" is a brief form of acknowledgment, and the letter "X" seems to serve the purpose better than anything else.

To illustrate; we will imagine that two trains are running along as follows:

No. 1	Meeting point	No. 2
B	C	A

We will assume that 1 at B is the train of inferior right, and C is the meeting point, and 2 at A is the train of superior right. Now if train 1 at B was already at the station, and there was a grade to make between that station and C (the meeting point) and the superior train had not yet arrived at A station, and dispatcher wanted to get inferior train started to avoid any delay by waiting until the train of superior right reached station A, he would simply have operator there "X" order, allowing operator at B to repeat and complete his order first, and the inferior train could then act upon the order. This is only one of a great many advantages obtained by using the abbreviated form of acknowledgment.

TRAIN ORDER NO. 87

Ottumwa Ia 12-16 19

To C & E Eng 1724 At Ottumwa Yards  
Station.

X McCarty Opr. 516 p M.

*Eng 1724 will run Extra Ottumwa to Maxson  
 on South track.*

O. E. S.

CONDUCTOR AND ENGINEMAN MUST EACH HAVE A COPY OF THIS ORDER.

*Made Complete Time 518 p M. McCarty Opr.*



## Definitions.

*Train.*—An engine, or more than one engine coupled, with or without cars, displaying markers.

*Regular Train.*—A train represented on the time-table. It may consist of sections.

*Section.*—One of two or more trains running on the same schedule displaying signals, or for which signals are displayed.

*Extra Train.*—A train not represented on the time-table, it may be designated as:

*Extra*—For any extra train except work extra.

*Work Extra*—For work train extra.

*Superior Train*—A train having precedence over other trains.

A train may be made superior to another train by Right, Class or Direction.

*Right*—Is conferred by train order.

*Class and Direction*—By time-table.

*Right*—Is superior to class or direction.

Direction is superior as between trains of the same class.

*Train of Superior Right*—A train given precedence by train order.

*Train of Superior Class*—A train given precedence by time-table.

*Train of Superior Direction*—A train given precedence in the direction specified in the time-table as between trains of the same class.

*Time-Table*—The authority for the movement of regular trains subject to the rules. It contains

the classified schedule of trains with special instructions relating thereto.

*Schedule*—That part of a time-table which prescribes the class, direction, number, and movement of a regular train.

*Single Track*—A track upon which trains are operated in both directions by time-table or train orders.

*Siding*—An auxiliary track for meeting or passing trains.

*Yard*—A system of tracks within defined limits provided for the making up of trains, storing of cars, and other purposes, over which movement not authorized by time-table, or by train orders, may be made, subject to prescribed signals and regulations.

*Yard Engine*—An engine assigned to yard service, and working within yard limits.

### **How Trains are Designated in Orders.**

Regular trains by time-table numbers; irregular by word "Extra" or "Special," and the engine number or conductor's name, or both; engines without trains by word "Engine" and its number; other trains as may be necessary to fully designate such trains.

### **Special Order "Rights."**

These orders mean simply what they express. Only such rights as are distinctly named therein,

giving no special rights whatever against any trains not mentioned in the order.

### Technical Terms.

The following technical terms used in railroad and telegraphic work should be studied carefully. Opposite each term is placed its definition.

*Bumpers* — Protecting irons placed at both ends of a car used to assist the drawback in deadening the jar.

*Cattle Guard* — A trench with pickets or latticed sharp rails alongside a crossing to prevent stock from trespassing on railroad's right of way.

*Coal Dump* — A small car used for dumping coal into the engine tenders.

*“D” Rail* — Used at interlocking crossings for derailing trains when they fail to obey signals.

*Draw Bar* — An open mouth bar at the end of a car, which receives a coupling link and pin by which the car is drawn.

*Engine Cab* — The apartment of the engineer and fireman.

*Engine Pilot* — The Cowcatcher — Projection attached to the front of the engine to clear the track of obstruction.

*Engine Tender* — A car attached to the engine for carrying water and fuel.

*First Out* — Generally applied to car or cars on sidings, as the first to be reached by an engine going on siding.

*Frogs* — A supporting plate having raised ribs

that form continuations of the rails to guide the flanges of the wheels where one track branches from another or crosses it.

*Guard Rail* — A rail placed on the inside of a main rail at switches, on bridges, etc., as a safeguard against derailment.

*Hot Box* — Caused by an excessive amount of friction produced by the axle revolving in the "truck" journal.

*S Curve* — Two curves close together on a railroad; a double curve.

*Siding or Side Track* — Used for allowing trains to pass, or for car storage.

*Spike* — Used for fastening rails.

*Splices* — Used for connecting rails.

*Stand Pipe* — Supply pipe for the flow of water from tank to engine.

*Tie* — Timbers supporting track.

### Cars.

*Baggage Car* — Used for carrying baggage.

*Barn Car* — A large box car.

*Box Car* — A closed freight car.

*Caboose* — A car fitted for use of freight crew.

*Coach* — A passenger car.

*Combination Coach* — Generally a car used for passengers and baggage, divided into one or more sections.

*Express Car* — Used for carrying express.

*Flat Car* — A car with simply a platform.

*Furniture Car* — A large box car used for carrying furniture and vehicles.

*Gondola* — A flat car with the side boards.

*Hand Car* — A small car propelled by hand.

*Mail Car* — A car used for carrying U. S. mail.

*Pile Driver* — A car used for driving piles.

*Refrigerator Car* — A car with ice vats, for carrying perishable freight.

*Stock Car* — A latticed box car used in transporting stock and sometimes coal.

### **Train Terms.**

*Accommodation* — A passenger which does local work.

*Extra or Exa* — Train not scheduled.

*Freight or Frt* — Made up of freight cars.

*Mixed* — Both freight and passenger cars.

*Passenger* — Made up of passenger, mail, and express cars.

*Regular* — Scheduled train.

*Special* — An extra train.

*Work* — A train doing road work.

## LESSON V.

## TELEGRAM.

Received From	Time	Sender	Receiver Receivee	Sent to	Time	Sender	Receiver
<i>On</i>	<i>8 a M</i>	<i>J</i>	<i>Sn</i>		<i>M</i>		

From *Lake City Ind* Filed *M.*  
 To *Condr No 6* At *Mapleton*

*Pick up Clevelands Minstrels Private Car at Charles City for  
 Dubuque*

*J. B. S.*

## Central Railroad Company.

## TELEGRAM.

All messages addressed to Officials on trains must be enclosed in sealed envelopes.

Saw my 2 Komenes Sta 3

Wilson R

Pick up 2 Cars traps at Gilmore  
2 Cars at Bremer and 4 Cars at  
Wash if necessary to fill out your  
train take as much small dead freight  
at Raufe as you need J.W.G.

## Central Railroad Company.

## TELEGRAM.

All messages addressed to Officials on trains must be enclosed in sealed envelopes.

Rn Wmk

Monon End 8/13-02

H J Loran. Div Supt  
on 18 East

Total deaths in last nights  
wreck estimated three all employees  
at V. G.



## Practical Railroad Messages.

Railroad messages must be received upon railroad blanks. Telegrams should be brief, and addressed and signed with full names, except when limited to one division, in which case initials may be used.

In addition to the office call, operators will sign their own private signal in sending or receiving telegrams, and such letters, with the time of sending, must be shown upon each telegram. Each message received must show on its face the office from which it was sent, the time received, and the signals of sending and receiving operators.

Telegrams addressed to officials must be put in envelopes, sealed, and properly addressed in every case. The contents of all telegrams must be held as confidential.

All railroad messages pertaining to the business of the company, of which no record is kept, are sent free of charge. They have no checks, are concise and brief, and are generally composed of many abbreviations.

### Railroad Telegrams.

*BX MK "BG"*

[Fm] *South Des Moines Iowa "Feb" 22 "1902"*

*Engr ex 98 & 100.*

*SF.*

*There is no water at Glad Brook.*

*Agt.*

RECEIVED TELEGRAM.	Rec'd from	Sent by	Rec'd by	Time Rec'd.
From <i>Des Moines Ia</i> To <i>E. Chambers, Supt</i> At <i>Minneapolis Minn.</i>	<i>67</i>	<i>DW</i>	<i>S</i>	<i>10.12</i>
<i>Can we unload the 10 rails            at X at once.</i>	<i>E. Williams</i>	<i>Foreman</i>		<i>1907</i>
				<i>10.13</i>

Operators are required to write all messages in ink.  
 The TIME filed as well as DATE filed must be transmitted. Telegrams for parties on trains (except those addressed to train men) must be enclosed in sealed envelopes

NOTE. — Parentheses and Quotation marks have the same uses in railroad work as they do in commercial work. The railroad business has no check, and the destination is usually known by the office call. For example OM is used in the second message for Omaha.

*BX MK "SF"*

[Fm] *Baxter Iowa "Feb" 22 "1902"*

[To] *WM,*  
*SX.*

*Steam shovel not working today account of broken injector and rain.*

*Wm Stoddart.*

*BX MK "RF"*

[Fm] *Valeria Iowa "Feb" 22 "1902"*

[To] *Agt,*  
*OM.*

*L S & M S is B O pls put it on house track.*

*C M,*  
*Car Repairer.*

*P MK "KN"*

[Fm] *Ames Iowa "Feb" 22 "1902"*

[To] *R A,*  
*Boone.*

*27 set off R I 2631 loaded with stk Chgo acct of broken axle.*

*E J S*

ON MK "HO"

[Fm] Boone Iowa "Feb" 22 "1902"

[To] Shusp Condr 26.

Pick up C M & St P 82371 at Nevada loaded  
with H H goods for Chgo.

E O Hoke.

### Yard Message.

BX MK "WS"

[Fm] Cedar Falls Iowa "Feb" 23 "1902"

[To] DSPR X.

"Yard"—or YD.

2	Wheat.....	Chgo.....	66 tons.
1	Corn.....		35 tons.
1	Corn.....	St Paul.....	36 tons.
2	Oats.....	Waterloo.....	53 tons.

Wanted

1 Stable at K hogs....Chgo..... 74 AM.

3 loc box corn 1 coal car props.

1 loc furn immigrants out for Kansas City  
Sunday.

BX.

NOTE. — In sending a message of this kind a period [ . ] should be made at the end of each line, and the receiving operator should drop down a line at each period. In this manner you get the correct form.

*BX MK "AW"*

[Fm] *Baxter Iowa "Feb" 22 "1902"*

[To] *C. P. S,*

*SX.*

*Steam shovel loaded today 65 rogers ana 30 flats.*

*1st train south..... 840 AM w 22 loads.*

*2nd " " ..... 1030 AM " " "*

*3rd " " ..... 1145 AM " 21 "*

*4th " north..... 105 PM " 21 loads.*

*5th " " ..... 430 PM " 23 loads.*

*6th " " ..... 545 PM " 24 "*

*8 loads and 6 mtys on hand.*

*J. L. S.*

**Make Up Report.**

*ON CN "AW"*

[Fm] *Bondurant Iowa "Feb" 22 "1902"*

[To] *D. S. C.,*

*SX.*

[.] *x 74 & 88 has :*

*3 sheep..... Chgo time 93 tons.*

*2 hogs..... 61 tons.*

*3 goats..... 90 tons.*

*2 hides..... 48 tons.*

*4 meat..... 132 tons.*

*1 loc bx Mtown..... 30 tons.*

*1 flat..... 20 tons.*

*1 furn..... 25 tons.*

*Sickas.*

*DX MK "A W"*

[Fm] *Waterloo Iowa "Feb" 22 "1902"*

[To] *R. P. Johnson,*

*WI.*

*Pls send me profile of Cedar Rapids gravel pit showing the lay of clay.*

*H. B. Merriam,*

*Dist Engr.*

---

*BX MK "BG"*

[Fm] *Marshalltown "Feb" 22 "1902"*

[To] *H. I.,*

*4man,*

*Jr.*

*Assist Anderson throw pit track tomorrow. Rush this work as we do not wish to delay steam shovel.*

*M. H.,*

*R. M.*

---

*BX MK "A W"*

[Fm] *Melbourne Iowa "Feb" 22 "1902"*

[To] *Agt,*

*Mtown.*

*Pls have 5 lunches ready by 10 am.*

*Druse,*

*x 96 & 108.*

*BX MK "HO"*

[Fm] *Ira Iowa "Feb" 22 "1902"*

[To] *M. N.,*

*R. M., Fn.*

*Send another man here in my place by next Monday.*

*S. J. B.,*

*4man.*

---

*ON. DO. "HM"*

[Fm] *Boone Iowa Feb 22nd-1902*

[To] *J. S. Milan,*

*Des Moines, Iowa.*

*This msg properly stamped and countersigned by you will be authority for C & N W condrs to pass Mr. J. E. Laws Des Moines to Boone if used on or before Dec 31st.*

*Hiram J. Slifer.*

---

*OR UK "HO"*

*Oralabor Iowa "Feb" 22 "1902"*

[To] *J. S. H.,*

*Boone Iowa.*

*Depot broken into last night. Ten dollars in cash stolen & 2 jugs whiskey tkn. One telegraph instrument destroyed.*

*L P G*

*Agt*

ON KO "A W"

Boone Iowa "Feb" 22 "1902"

[To] B. Y. George,

Des Moines Iowa.

*Tnk I wi b in Des Moines on no 13 tonight.  
May cm on no 9.*

J A S

---

IN IM "HO"

Boone Iowa "Feb" 22 "1902"

W A G,

Agt,

Ky.

*Cant send u any coal until tmw. Try & gt  
along w wt u hv till tn.*

R A

---

.PC. MN. "HO"

Polk City, Iowa Feb 22nd-1902

A. J. Heinlein,

Car Repairer,

Boone, Iowa.

*Have one 60 ton car loaded with wheat with  
king-bolt broken Come at once.*

Ole Oleson,

Agt.



# Central Railroad Company. TELEGRAM.

All Railway messages received on these blanks must be written in ink and those for parties on trains (except trainmen) enclosed in sealed envelopes. The exact time and receiving or sending time, initials of sending and receiving operators, signal of sending office and name of receiving office must be entered in proper spaces in every instance.

—RECEIVED AT—				Office.—SENT FROM—				
From Office Call.	Sender.	Receiver.	Time and Date Rec'd M. . . . .	TIME FILED. 9 30 a . . . . . M. . . . .	Time and Date Sent. 9 36 a . . . . . M. 1/2	Sender.	Receiver.	To Office Call.

From Waverly Office 7/5 1902  
 To E. J. Baxter At Manchester

Please help invited from  
 no six to make change to  
 other road.

John J. Lewis

*.ON. ME. "HO"*

*Perry, Iowa, Feb 22nd-1902*

*Nels Madtson,*

*Madrid Iowa.*

*Lay off 3rd and 4th men today. 1st and 2nd men may each work hlf time until further notice.*

*J. A. Strom.*

*R. M.*

---

*PY. OD. "HO"*

*Perry, Ind. Feb 22nd-1902*

*H. F. Omally,*

*Sec 4man Sec No 67,*

*Jefferson, Ind.*

*You will help Oliver space ties tmw near mile post 891 Sec 68.*

*J. R. King.*

---

## LESSON VI.

### Railroad Abbreviations Used on Wire.

Q. Hw mch wk hs 54 to do tr et?

How much work has 54 to do there yet?

A. Cnt sa ty r dwn west end o yard nw.

Cant say they are down west end of yard now.

Q. Wt is 75 dng tr nw?

What is 75 doing there now?

- A. Gtg 3 mt bx fo Br.  
Getting 3 empty box cars for Burlington.
- Q. Hw sn wi 2nd 83 b rdy ?  
How soon will 2nd 83 be ready ?
- A. Sn ty gt c & w.  
Soon as they get coal and water.
- Q. Cld 76 mk ON if I gv em 15 mins on 9 ?  
Could 76 make Boone if I give them 15 minutes on No. 9 ?
- A. Ses he cn mk it art.  
Says he can make it all right.
- Q. Wts t wtr tr wh wa wnd blwg ?  
What is the weather there which way wind blowing ?
- A. Fr S E Wnd.  
Fair south east wind.
- Q. Hw mch water u got ?  
How much water you got ?
- A. 4 ft mill nt rung.  
4 foot mill not running.
- Q. Wr u bn ?  
Where have you been ?
- A. Bn out wi mail.  
Been out with mail.
- Q. Hs tt x ar et ?  
Has that extra arrived yet ?
- A. Tr cmg, I jst hrd em whistle.  
They are coming. I just heard them whistle.
- Q. Hw fr awa ?  
How far away ?
- A. Abt 2 mi nw.  
About 2 miles now.

—I wnt u to ans ur call.

I want you to answer your call.

—Hrs a msg.

Here is a message.

—We gt 2 E lds hr Meadows ses he hs all he wnts.

We have got 2 east loads here. Meadows says he has got all he wants.

—Tt so, tk ts clip.

That so, take this clip.

*Go. W.*

*Denver Colo Feb 22nd-1902*

[To] *Meadows*

*Vj.*

*Pick up 2 loads at Brandon.*

[Sig] *J. W. G.*

NOTE.— In sending a railroad message to the superintendent's office from a station along the line, it is quite common to send the initials of the person to whom the message is addressed before sending the message proper. Example :

[Hr. J. W. G.] *FS. FN.*

[Fm] *Beatrice 22*

[To] *J. W. G.*

*Denver.*

*Tank on engine 316 leaks badly. She can not handle rating tonight.*

[Sig] *English.*

## LESSON VII.

**Common Railroad Abbreviations.**

Ads — Address.	Cod — Collect on delivery.
Abd — Aboard.	C I F — Cost Ins. Freight.
Abt — About.	C F I — Cost Frt. Ins.
Agt — Agent.	Cld — Could.
Agn — Again.	C & W — Coal and water.
Ahr — Another.	Ckt — Circuit.
Amt — Amount.	Ck — Check.
Ans — Answer.	Cm — Come.
Adj — Adjust.	Clk — Clerk.
A or Ar — Arrived.	Ct — Cent.
Art — All right.	Cndr — Conductor.
B — Be.	Da — Day.
Bf or B4 — Before.	Dd — Did.
B M — Baggage man.	Dng — Doing.
Bn — Been.	D H — Deadhead.
Bty — Battery.	Dn — Done.
Bbl — Barrel.	Ds — Does.
Bnd — Bound.	Dwn — Down.
Bag — Baggage.	D or De — Departed.
Bk — Break.	E — East.
Bot — Bought.	Ex — Express.
Btw — Between.	Ehr — Either.
Btr — Better.	Eng — Engine.
Bal — Balance.	Engr — Engineer.
Bx — Box.	Evy — Every.
Biz — Business.	Exa — Extra.
Cn — Can.	Es — Yes.
Co — Company.	Fi — Fire.

Fr or fm — From.	Impsbl — Impossible.
Frt — Freight.	Impt — Important.
Fwd — Forward	Kp — Keep.
Fst — Fast.	Kw — Know.
Fob — Free on board.	Lv — Leave.
Ga — Go ahead.	Lrn — Learn.
Gd — Good.	Ltr — Letter.
Gng — Going.	Ma — May.
Gv — Give.	Mgr — Manager.
Gm — Good morning.	Md — Made.
Gb — Good bye.	Mk — Make.
Gn — Good night.	Mch — Much.
Genl — General.	Mo — More.
G W — Ground wire.	Mt — Empty.
Gnd — Ground.	Mv — Move.
Gte — Guarantee.	Min — Minute.
Gtd — Guaranteed.	Msk — Mistake.
G B A or G S A — Give	Mtr — Matter.
better, or some address.	Msg — Message.
Hv — Have.	Msgr — Messenger.
Hs — Has.	N — Not.
Hd — Had.	Nite — Night.
Hlf — Half.	Nm — No More.
Hi — High.	No — Number.
Hy — Hurry.	Nr — Near.
Hm — Him.	Ns — News.
Hr — Here.	Nvr — Never.
Htl — Hotel.	Nsy — Necessary.
Hw — How.	Ntg — Nothing.
Hvy — Heavy.	Nn — None.
Immy — Immediately	OK — Correct.
Instr — Instrument.	Ot — On time.

Ovr — Over.	T — The.
Ofr — Offer.	Tt — That.
Opr — Operator.	Tf — Tariff.
O S — Order Sheet.	Toda — Today.
Pa — Pay.	Tng — Thing.
Pd — Paid.	Tk — Take.
P O — Post Office.	Tnk — Tank.
Pls — Please.	Tnx — Thanks.
Passgr — Passenger.	Tm — Them.
Pt — President.	Ti — Time.
Qk — Quick.	Tn — Then.
Rite — Right.	Tr — There.
Rpt — Report.	Ts — This.
Rtn — Return.	Twn — Town.
Rlf — Relief.	Ty — They.
Sa — Say.	Tel — Telegraph.
Shld — Should.	Tho — Though.
Sch — Such.	Thot — Thought.
Sm — Some.	Tmw — Tomorrow.
Sn — Soon.	Tru — Through.
Ses — Says.	Tkt — Ticket.
St — Street.	Trn — Train.
So — South.	U — You.
SF B — Stop for Break- fast.	Ur — Your.
SF D — Stop for Dinner.	Ux — Underline.
Sfn — Stop for night.	Und or 13 — Understand.
Sig — Signature.	Vy — Very.
Sml — Small.	Wi — With.
Stk — Stock.	Wa — Way.
Smtg — Something.	WB — Waybill.
Supt — Superintendent.	Wh — Which.
	Wld — Would.

Wk — Week.

Wrk — Work.

Wl — Will.

Wn — When.

Wr — Where.

Wt — What.

Wy — Why.

Wthr — Weather.

Wrd — Word.

Ws — Was.

Yr — Year.

Yd — Yard.

NOTE. — Make thirty different practical railroad messages on the order of those in the preceding lesson, using as many abbreviations as practical.

---

**Example of Messages sent to Agents which are Copied by all Operators Simultaneously.**

[Hr a msg] *GI. WE.*

[Fm] *Chicago, Ills. 22*

[To] *All Agents.*                   [.]

*Please search your baggage and freight room for large yellow grip with tag on side bearing numbers 239 in large type and advise this office if found, by wire, if not by letter.*

[Sig] *G. H. Dudley.*

---

[Hr Clip] *GI. W. E.*

*Chicago, Ills. 22*

[To] *All Agents.*                   [.]

*Your attention is called to circular No. 4429. Please be particular to see that all cars are loaded to capacity and ten percent thereon. All shortage will be greatly ameliorated if these rules are followed.*

[Sig] *C. B. Thomas.*



## LESSON VIII.

### Signals.

#### Station Signals.

All employes whose duty requires them to give signals, must provide themselves with the proper appliances, and keep them in good order and always ready for immediate use.

#### Flags and Lamps.

Flags of the proper color must be used by day, and lamps of the proper color by night, or whenever, from fog or other causes, the day signals can not be seen.

#### Red.

Signifies DANGER, and is a signal to stop.

#### Green.

Signifies caution, and is a signal to go slowly.

#### White.

Signifies safety, and is a signal to go on.

#### Green and White.

Is a signal to be used to stop trains at flag stations for passengers or freight.

#### Blue.

Is a signal to be placed on car to forbid its being moved.

### **Torpedoes.**

A torpedo, placed on top of a rail, is a signal to be used in place of the regular signals. The explosion of one torpedo is a signal to stop immediately; the explosion of two, not more than two hundred feet apart, is a signal to reduce speed immediately and look out for danger ahead.

### **Fusees.**

A fusee is a signal that may be used in addition to torpedo or other signals.

### **Danger Signals.**

A flag or lamp swung across the track, a hat or any object waved violently by any person on the track, signifies danger, and is a signal to stop.

### **Whistle Signals.**

Whistle signals vary so much on all roads that the author believes it advisable to allow the student to study them from his book of Rules and Regulations received from the company which first employs him, so as not to confound them with others.

### **Signals Carried on Engines and Trains.**

Two green flags by day and in addition two green lights by night, displayed in the places provided for that purpose on the front of an engine, denote that the train is followed by another train running on the same schedule and entitled to the

same time-table rights as the train carrying the signals.

#### **White Signals.**

Two white flags by day, and in addition, two white lights at night, displayed in the places provided for that purpose on the front of an engine, denote that the train is an extra. These signals must be displayed by all extra trains, but not by yard engines.

#### **Markers.**

The train, while running, must display two green flags by day and two green lights by night, one on each side of the rear of the train, as markers to indicate the rear of the train. Yard engines will not display markers.

#### **Running Backwards.**

The markers will be found on the pilot of an engine at night when the engine is running backwards.

#### **Tail Lights.**

Markers show green to the front and sides, and red to the rear. Red lights in this position are termed tail lights.

## Hand, Flag, and Lamp Signals.

### Hand Signals.

MANNER OF USING.	INDICATION.
Swung across track . . . . .	Stop.
Raised and lowered vertically . .	Go ahead.
Swung vertically in a circle across the track when the train is standing . . . . .	Back up.
Swung vertically in a circle at arm's length across the track when train is running . . . . .	Train parted.

**Hand and Lamp Signals.**

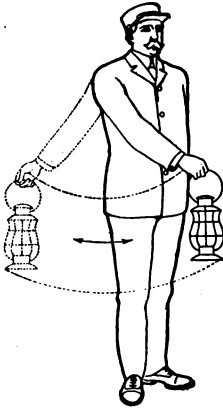

**Stop.**

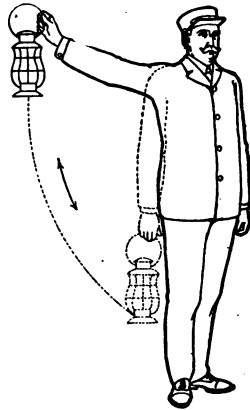

**Go Ahead.**

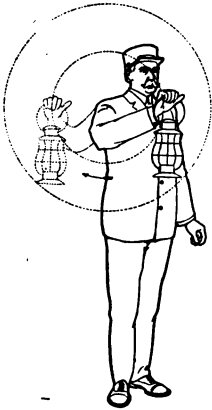

**Back Up.**

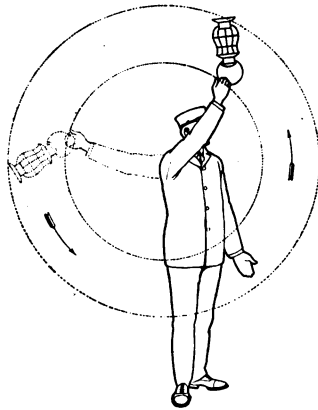

**Train Parted.**

## Engine Signals.

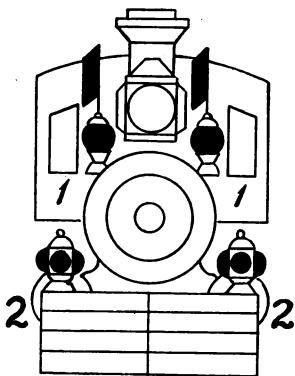

Locomotive running backward by night without cars. Carrying Signals for Following Train. Green Lights and Flags at 1 — 1 Signals. 2 — 2 Markers.

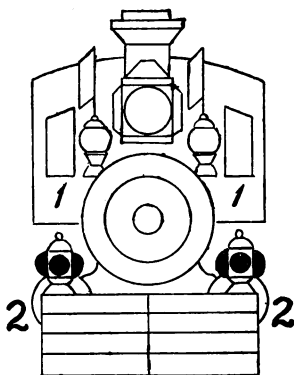

Locomotive running backward by night without cars. Running Extra. Denoted by White Lights and Flags at 1 — 1. Markers at 2 — 2.

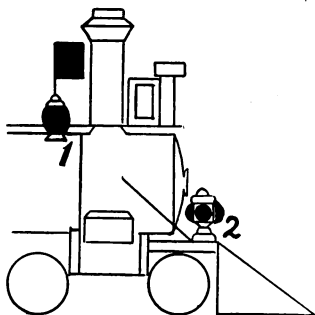

Locomotive running backward by night without cars. Signals for Train Following are Green Light and Flag at "1." 2 — Markers.

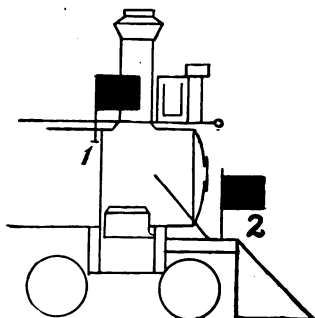

Locomotive running backward by day without cars. Carrying Signals for Train Following. Denoted at "1" by Green Flag. 2 — Markers.

**Markers.**

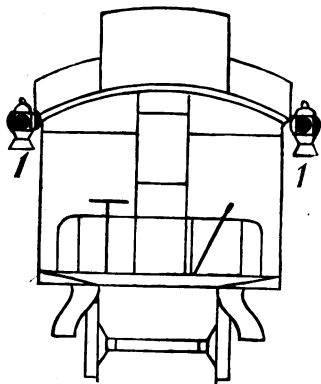

Rear of train by night when on siding.  
Markers, 1—1.

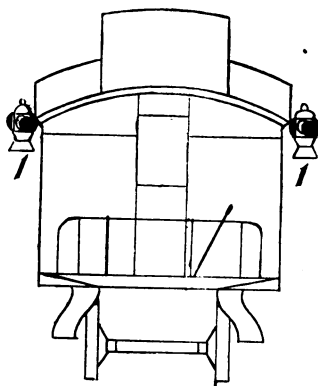

Rear of train by night while running.  
Red to Rear.  
Green to Sides and Front.

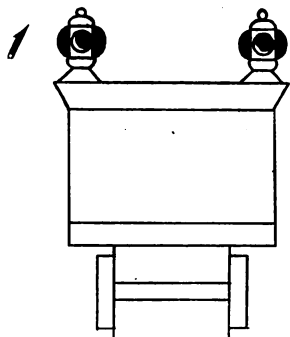

Locomotive running forward without cars by night.

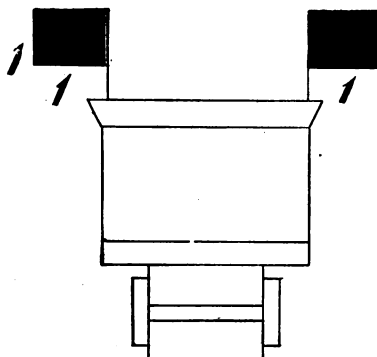

Locomotive running forward without cars by day.

Markers, 1—1.

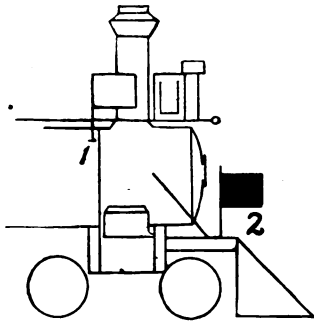

Locomotive running backward by day without cars or pushing cars, and Running Extra, denoted by White Flag at "1." Green at 2 Markers.

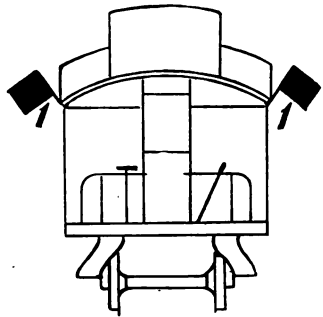

Rear of Train by Day. Markers at 1-1.

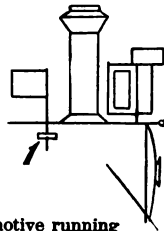
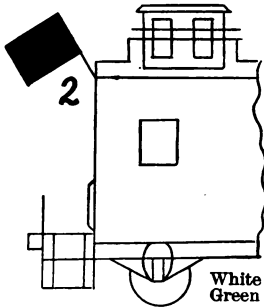

Locomotive running forward by day. Running Extra.

White Flag at "1" denotes "Extra." Green Flag at "2" Markers.

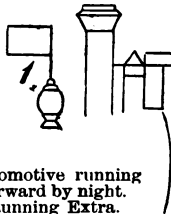
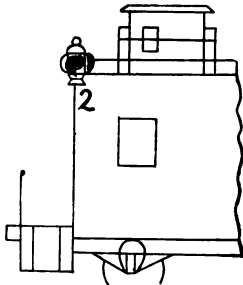

Locomotive running forward by night. Running Extra. White Light and Flag at "1" denote "Extra." 2- Markers.



**Markers and Engine Signals.**

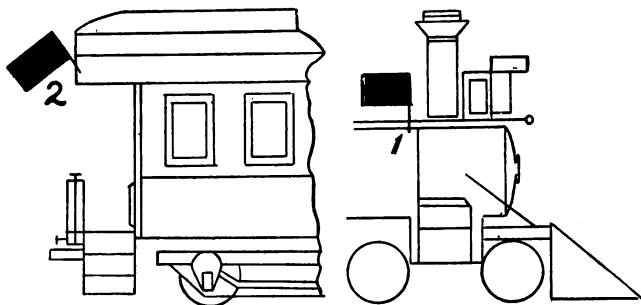

Locomotive running forward by day carrying signal for Train Following.  
Green Flag at "1" for Train Following.  
2—Markers.

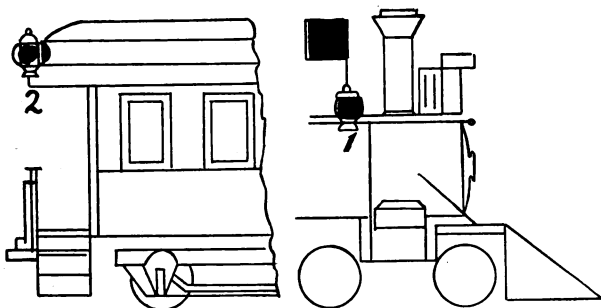

Locomotive running forward by night carrying signal for Train Following.  
1—Signal for Train Following.  
2—Markers.

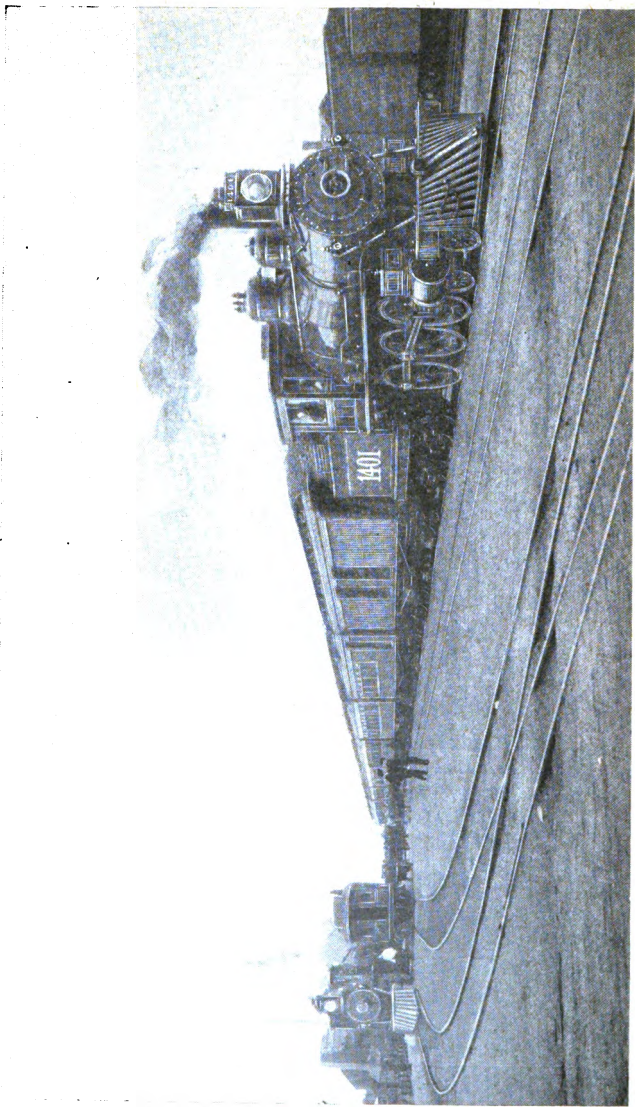

The "Overland Limited." Movement controlled by a thoroughly educated telegraph operator.

## PART V.

### LESSON I.

#### “31” Train Orders.

When an operator receives “31” he must immediately display “RED” and hold his order board against all trains until the object for which it is out is accomplished.

Write all copies of your orders at once. To enable you to do this the dispatcher will, when he raises each office, say: “31 copy —,” stating the number of copies.

After all offices affected have been raised by the dispatcher, and before transmitting the text or body of the order, he says: “Copy Order No. —,” and then addresses the train of superior rights, as a general rule, first. Example:

To Jn to C & E No 2 Jn

To Bn to C & E No 1 Bn.

NOTE. — “Jn” represents the office call of the first town to copy, and “Bn” that of the second. Being addressed in this manner, the operator knows for which train he is copying orders.

Having addressed the several offices in the succession in which they are expected to repeat, the dispatcher generally proceeds by either saying “Cy” [meaning copy], or making several periods

[.], upon which all begin to copy the body or text of the order.

During the progress of the order if you miss a word, you should immediately break [Bk], repeating the last word received in this manner: "Bk GA —," and sign your office call. In this manner the other operators copying recognize the "break" and are not confused.

When an order has been transmitted preceded by the signal "31," operators copying it must repeat it back at once in the succession in which their several offices have been addressed.

After an order has been repeated correctly, the response "OK" authorized by the train dispatcher will be sent simultaneously to as many as practicable, naming each office. Each operator must write this on the order, with the time, and then reply "i i ok" with his office signal.

Those to whom the order is addressed, except enginemen, must then sign their names to the copy of the order to be retained by the operator, and he will send their signature, preceded by the number of the order, to the train dispatcher.

The dispatcher will then send the response, "Complete," and the "time," with the proper initials.

The operator receiving this response will write on each copy the word, "Complete," the "time," dispatcher's initials, and his own name in full; and will deliver a copy to the proper persons addressed.

For an order preceded by the signal "31," "Complete" must not be given to the order for delivery to a train of inferior right until "OK" has

been given to and acknowledged by the operator who receives the order for the train of superior right. Whenever practicable, the signature of the conductor of the train of superior right must be taken to the order, and "Complete" given before the train of inferior right is allowed to act on it.

After "OK" has been given and acknowledged, and before "Complete" has been given, the order must be treated as a holding order for the train addressed, but must not be otherwise acted upon until "Complete" has been given.

If a line fails before an office has received and acknowledged "OK" to an order preceded by the signal "31," the order at that office is of no effect, and must be treated as if it had not been sent.

The order, the "OK," and the "Complete" must each, in transmitting, be preceded by "31" and the number of the order, thus :

"31, No. 10."

In transmitting the signature of a conductor it must be preceded by "31," the number of the order, and the train number, thus :

"31 No 10 [sig] Jones Train No 5."

After each transmission and response, the sending operator must give his office signal.

The dispatcher in his response would say :

"31 Order No 10 'Complete' 5:10 p. m. G. M. B."

The figures 5:10 represent the time, and G. M. B. the dispatcher's initials.

The operator who receives and delivers an order must preserve THE LOWEST COPY. On this

must appear the signature of those who sign for the order, and on it, he must record the time he received it, his own name, the date and train number, for which, places are provided in the orders.

“31” Forms.

Central Railroad Company.

TELEGRAPHIC TRAIN ORDER No. 4  
Trainmaster's Office Perru Ind <sup>6/10</sup> <sub>1902</sub>

FORM 31 For Montpelier to C & E No 71 FORM 31

No seventy one 71 Eng 233  
has right of track over  
1st & 2nd no sixty two 62  
Engs 759 and 763 Montpelier  
to Butler

CONDUCTOR AND ENGINEMAN MUST EACH HAVE A COPY OF THIS FORM.

Time received 11:40 a.m. OK given at 4:42 a.m.

CONDUCTOR.	TRAIN.	MADE	AT	RECEIVED BY
<u>Lock</u>	<u>71</u>	<u>Complete</u>	<u>5:10 a</u>	<u>Patton</u>

# Central Railroad Company.

TELEGRAPHIC TRAIN ORDER No. 28

Form 2710.

Superintendent's Office, Marshall 7/9 1902

31

For Grinnell to Engs or 32 & 39

31

Engs 32 & 39 will double  
head and run Extra  
Grinnell to Ashkaloosa and  
meet Extra 31 north at  
Eddyville

*ABD*

CONDUCTOR AND ENGINEER MUST EACH HAVE A COPY OF THIS ORDER.

Time received. 3:21 P M OK gives at 3:40 P M

CONDUCTOR AND ENGINEER	TRAIN.	MADE	AT	RECEIVED BY
<i>McLullough</i>	<i>32</i>	<i>Engs</i>	<i>3:40</i>	<i>Meyer</i>
<i>Vand</i>	<i>39</i>			





Central Railroad Company.

TELEGRAPHIC TRAIN ORDER No. 92

Treasurer's Office London 16 June 1882

31 | to Reterton 1/2 | to Ore | Ex 2383 west | 31

Eng 0111 Shaffer runs Steele extra  
 Oage City to Burlington with  
 right of track over No 63 eng 174  
 and will meet extra 2383 west  
 Stafford at Reterton

*caq*

CONDUCTOR AND ENGINEMAN MUST EACH HAVE A COPY OF THIS FORM.

Time received	M.	given at	M.
<i>Stafford</i>		<i>Ex 2383 complete</i>	<i>Stafford</i>

## LESSON II.

## The 31 "X" Orders.

## Practical Work.

## Central Railroad Company.

TELEGRAPHIC TRAIN ORDER NO. 14Dispatcher's Office Des Moines Feb 6 19To C. & E. 204At RolfeFORM  
31X. O. K. at 8:36 P. M. E. Howell Operator.No two hundred four 204 Eng 244 and twothirty one 231 Engs 330 and 316 doubleheaderwill meet at PerryJ. W. B.Order No. 14 O.K. at 8:37 P. M. E. Howell Operator.

CONDUCTOR	TRAIN NO.	COMPLETE	AT	DISPATCHER	OPERATOR
<u>Wilson</u>	<u>204</u>	<u>Complete</u>	<u>8:32 a</u>	<u>J. A. H.</u>	<u>Howell</u>
				<u>v.</u>	

## “31” Orders Containing the “X” (Acknowledgment by Operator.)

### As Overheard on the Wire.

(With Notes.)

“GO”—Dispatcher’s office call.

“FS”—Beacon, Iowa, office call.

“GN”—Leighton, Iowa, office call.

Meaning of each abbreviation following :

“Cy—copy”; “3—number of copies”; “U—you”; “& or es—and”; “31—Telegraphic order”; “9—Clear wire for orders”; “Hr—Here.”

Example of all that goes over the wire from start to finish :

[Dspr] *Hr. 9 gn, gn 9 go.*

[Opr Gn] *I I GN.*

[Dspr] *31 cy 3 u & fs fs fs 9 go fs fs fs go.*

[Opr Fs] *I I FS.*

[Dspr] *cy 3 u & gn.*

*Order 13*

*Go-3 [Des Moines Feb 3rd]*

*To FS C & E 233 FS*

*To GN C & E 234 GN [.] [.]*

*Number two thirty three 233 eng 316 and two thirty four 234 eng 338 will meet at Leighton. This order will be delivered to train 234 at the meeting point.*

*J. W. B.*

[To] *Gn X.*

[Opr Gn] *Order No 13 C & E 234 X. F. L. M.*

[Dspr] *31 No 13 X F. L. M. OK 835 H. D. G.*

[Opr Fs] *Order 13 C & E 233 FS X F. E. P. [.]*

*No. two thirty three 233 eng 316 and two thirty four 234 eng 338 will meet at Leighton. This order will be delivered to train 234 at the meeting point.*

[Sig] *Jones.*

[Dspr] *31 Go No 13 F E P X & Order Ok & Complete 840 H. D. G. hr clip*

---

**Pick Up Message.**

*Go. W.*

*Des Moines Iowa 3rd*

[To] *Condr 233.*

*FS.*

*Pick up four stock at Given 1 car at Otley 1 at Pioneer and 7 at Oskaloosa. You need not handle any dead frt on this run.*

*J. W. B.*

---

**Other Orders and Pick Up Messages.**

[Dspr] *31 Cy 3 Order No 14*

*Go-3*

[To] *Rf C & E 204 RF [.]*

*No two hundred four 204 eng 244 and no two thirty one 231 engs 330 and 316 double header will meet at Perry.*

*J. W. B.*

[Opr Fs] 31 Order No 14 C & E 204 Rf X E.  
 H. [. ] No two hundred four 204 eng 244 and no  
 two thirty one 231 engs 330 & 316 double header will  
 meet at Perry. [Sig] Wilson.

[Dspr] 31 Order 14 E. H. X & Order O K &  
 Complete 837 J. A. H. Hr. 1.

---

**Pick Up Message.**

Go.

*Des Moines 3*

*Wilson*

*Rf.*

*Pick up 2 cars hogs at Gilmore 2 cars at Pioneer  
 and 4 cars at Wolf if necessary to fill out your  
 train take as much dead freight at Rolfe as you  
 need.*

*J. W. B.*

---

[Dspr] Cy 3

*Order 23. Go-3*

[To] FS to Eng 224 FS [. ]

*Eng 224 will work extra Feby 3rd between  
 Evans and one mile and a half east of Beacon and  
 between Beacon and Oskaloosa will run not to  
 exceed fifteen 15 miles an hour backing up.*

*J. W. B.*

[Opr FS] 31 FS No 23 To Eng 224 X F. E. B. [. ]  
*Eng 224 will work extra Feby 3rd between Evans  
 and one mile and a half east of Beacon and between  
 Beacon and Oskaloosa will run not to exceed fifteen  
 15 miles backing up.* [Sig] Cross.

[Dspr] 31 Go No 23 F. E. B. X & Order OK &  
 Complete 849 H. D. B.

## The 31 "X" Schedule Order.

TELEGRAPHIC ORDER NO. 58Dispatcher's Office, Des Moines Iowa Feb 2To C & E All trains west except first class.at BrooklynX. O. K. at 12:33 M. Jones Operator.

Engs 1106 and 1239 will run as two (2) extras leaving Des Moines on Sunday Feby 2nd on the following schedule and will have right of track over all trains except No ninety seven 97 and no ninety one 91 no ninety two 92 and all first class trains:

Leave Des Moines	one ten 1:10 pm.
Altoona	one forty five 1:45 pm.
Mitchellville	two o'clock 2:00 pm.
Colfax	two twelve 2:12 pm.
Metz	two twenty seven 2:27 pm.
Newton	two forty one 2:41 pm.
Emboy	two fifty two 2:52 pm.
Kellogg	three o'clock 3:00 pm.
Turner	three twelve 3:12 pm.
Grinnell	three twenty seven 3:27 pm.
Malcom	three forty three 3:43 pm.
Brooklyn	three fifty five 3:55 pm.
Victor	four twelve 4:12 pm.
Ladora	four twenty four 4:24 pm.
Marengo	four thirty seven 4:37 pm.
So Amuna	four forty eight 4:48 pm.
Homestead	five o'clock 5:00 pm.
Oxford	five ten 5:10 pm.
Tiffin	five twenty five 5:25 pm.
Iowa City	five forty three 5:43 pm.
Donney	six five 6:05 pm.
Arrive West Liberty	six twenty 6:20 pm.

F. B. R.

Order No. 58 O. K. at 12:35 p. M. Jones Operator.

Conductor	Train	Complete	At	Dispatcher	Operator
<u>Jones</u>	<u>9</u>	<u>Complete</u>	<u>12:45</u>	<u>J B S</u>	<u>Jones</u>

## LESSON III.

**Standard Train Order Forms.****Texts.****Form of Train Orders.**

FORM A. — Fixing a meeting point for opposing trains.

\_\_\_\_\_ and \_\_\_\_\_ will meet at \_\_\_\_\_

---

**Examples.**

*No 3 Eng 55 and No 12 Eng 53 will meet at Vinton.*

---

*No 5 Eng 33 and 2nd No 14 Eng 7 will meet at Ottumwa.*

---

*No 1 Eng 11 and Extra East Eng 25 will meet at Otis.*

---

*Extra West Eng 171 and Extra East Eng 321 will meet at Ames.*

---

NOTE. — When train having right of track at the meeting point, gets its orders there, the opposing train must approach meeting point with care and under control. The following addition to such an order is therefore necessary :

“This order will be delivered to train No. \_\_\_\_\_ at meeting point.”

---

FORM B. — Authorizing a train to run ahead of or pass another train running in the same direction.

\_\_\_\_\_ will pass \_\_\_\_\_ at \_\_\_\_\_

(or)

\_\_\_\_\_ will run ahead of \_\_\_\_\_, \_\_\_\_\_ to \_\_\_\_\_.

**Examples.**

*No 11 Eng 3 will pass No 13 Eng 88 at Kankakee.*

---

*No 14 Eng 66 will run ahead of No 16 Eng 9 Ames to Boone.*

---

FORM C. — Giving a train of inferior right THE RIGHT OF TRACK over an opposing train of superior right.

\_\_\_\_\_ has right of track over \_\_\_\_\_ to \_\_\_\_\_.

---

**Examples.**

*No 1 Eng 77 has right of track over No 12 Eng 78 Clare to Olin.*

---

*Extra East Eng 22 has right of track over No 5 Eng 44 Boone to Otis.*

---

*Work Train Eng 333 has right of track over all trains between Carroll and Everetts from eight 8 pm.*

---

FORM D. — Giving all regular trains the right of track over a given train.

All regular trains have right of track over \_\_\_\_\_ between \_\_\_\_\_ and \_\_\_\_\_.

---

**Example.**

*All regular trains have right of track over No 11 Eng 12 Between Adair and Clive.*

---



## FORM E.— Time Orders.

\_\_\_\_\_ will run \_\_\_\_\_ late \_\_\_\_\_ to \_\_\_\_\_  
 \_\_\_\_\_ will wait at \_\_\_\_\_ until \_\_\_\_\_ for \_\_\_\_\_.

*No one 1 Eng 23 will run twenty 20 mins late  
 Cain to Otis.*

*No two 2 Eng 11 will wait at Joplin until ten  
 10 pm. for No 33 thirty three Eng unknown.*

## FORM F.— Sections of Regular Trains.

\_\_\_\_\_ carry signals \_\_\_\_\_ to \_\_\_\_\_ for \_\_\_\_\_.  
 \_\_\_\_\_ will run as \_\_\_\_\_ section of \_\_\_\_\_ to \_\_\_\_\_.

## Examples.

*No thirteen 13 Eng 44 will carry signals Alta  
 to Fonda for Eng 777.*

*Eng 777 will run as second 2nd section No  
 thirteen 13 Eng 44 and carry signals Alta to Fonda  
 for Eng 66.*

*Engines 44 and 777 and 66 will run as first 1st  
 second 2nd and third 3rd sections No thirteen 13  
 Alta to Fonda.*

## FORM G.— Schedule for Extra Train.

Eng \_\_\_\_\_ will run special, leaving \_\_\_\_\_ on  
 \_\_\_\_\_ on the following schedule, and will have  
 the right of track over \_\_\_\_\_.

Leave \_\_\_\_\_

Arrive \_\_\_\_\_

**Example.**

*Eng No 99 will run special, leaving Boone on Friday, Feb 22nd on the following schedule, and will have right of track over all trains except ninety nine 99 Eng 34 and seventy one 71 Eng unknown.*

*Leave Boone one ten 1:10 pm.*

*Ogden one fifteen 1:15 pm.*

*Mongonia one thirty 1:30 pm.*

*Grand Jct one fifty 1:50 pm.*

*Arrive Carroll two fifty 2:50 pm.*

FORM H.—

**Extra Trains.**

\_\_\_\_\_ will run extra \_\_\_\_\_ to \_\_\_\_\_

**Example.**

*Eng 33 will run extra Newton to Grinnell.*

NOTE. — A “work train” is an extra, and the above form is used for a direct run in one direction.

FORM I. —

**Work Train Orders.**

*Eng 676 will work seven 7 a. m. until six 6 p. m. between Taylorville and Perry.*

*Eng 565 will run Extra Boone to Carroll and work 9 a. m. until 5 p. m. between Carroll and Arcadia.*

**FORM J. — Holding Order.**

Hold \_\_\_\_\_ at \_\_\_\_\_.

---

*Hold No twenty two 22 Eng 55 at Canton for orders.*

---

**FORM K. — Annuling a Scheduled Train.**

\_\_\_\_\_ of \_\_\_\_\_ is annulled.

---

*No eleven 11 Eng 578 of February 23rd is annulled.*

---

**FORM L. — Annuling an Order.**

Order No. \_\_\_\_\_ is annulled.

---

*Order number thirty six 36 is annulled.*

---

**Telegraph Block Signals.**

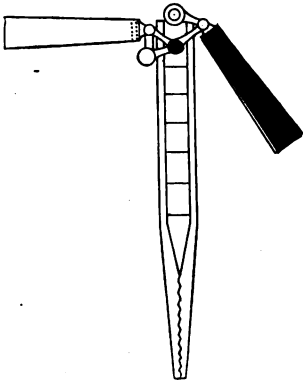

**Go Ahead.**  
(Single Track.)

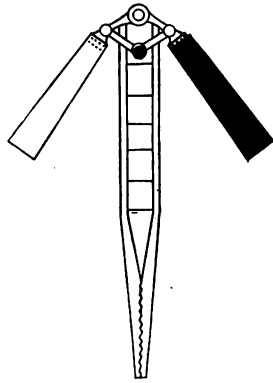

**Go Ahead.**  
(Double Track.)

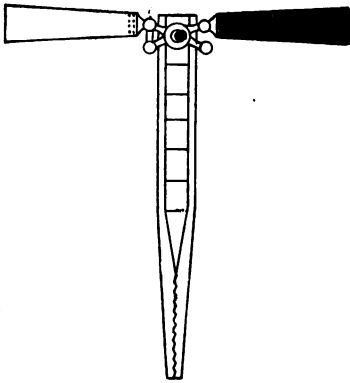

**Stop.**  
(Single Track.)

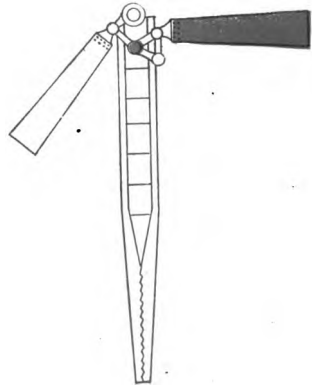

**Stop.**  
(Double Track.)

## PART VI.

---

### LESSON I.

#### **Block Signaling.**

##### **Definitions.**

*Absolute Block*—A railway supposed to be divided into certain sections of a given length termed blocks. No two trains or engines, except double-headers, are allowed, or are supposed to be allowed, to enter any one section at the same time.

*Permissive Block*—Under certain circumstances, or by authority of the dispatcher, more than one train or engine is permitted to occupy a block at the same time, providing each train is notified whether the block is occupied or not, by the use of a CAUTION CARD, or second part of a RELEASE, where they meet at an intermediate siding or non-telegraph office.

*Manual Block System*—This applies where the signals are operated manually, and by its construction requiring the co-operation of the signalmen at both ends of the block to display signals.

*Distinct Circuit*—Where the system requires a distinct circuit from station to station, and the constant attention of operators to their respective duties.

### General Explanation of Block Signals.

The signals generally used are of the semaphore pattern, which consists of a post and arm, pointing to the right for all trains whose movements it governs. The position of the arm, or the color of the light displayed, indicate CAUTION, DANGER, or SAFETY.

The block signals are also used for train orders, and all rules applying to train orders.

### Red

Is an indication that the block is NOT CLEAR, and signifies STOP.

The HORIZONTAL position of the semaphore arm is the equivalent of "Stop."

The DIAGONAL position is the equivalent of "Proceed."

In blocking trains ten minutes apart the following rules will be observed: (A) As soon as the rear car, carrying markers, passes your signals, display signals at "danger" position, keeping them in that position until ten minutes have elapsed. No exception to this rule will be allowed unless authority for the same is received from the dispatcher. (B) The train dispatcher may authorize an operator to allow a train to follow another in less than ten minutes, by the use of the CAUTION CARD, in which event he will send an order of the following form:

Signalman at \_\_\_\_\_

Issue card No. \_\_\_\_\_ to No. \_\_\_\_\_

OK time \_\_\_\_\_ M

\_\_\_\_\_ Train Dispatcher.

(C) The only exception allowed train dispatchers, as per example (B), is when a train requires the assistance of a following train, or when trains close up at meeting or passing points, and then only when weather and grade conditions are favorable. In the latter case no exception will be made in allowing any train to follow a passenger train.

Block signals are used to control the movement of trains upon the main track, and must NOT be accepted by trains on sidetracks.

Proper authority must be obtained from signalmen before proceeding, by trains arriving at a block station where signal is at "Stop," by trains occupying sidetracks, or by trains starting from terminal stations.

"Proper authority" consists of :

(A) A Caution Card and Release.

(B) A Release stamped "BLOCK IS CLEAR."

(C) A Train Order stamped "BLOCK IS CLEAR."

(D) Train Orders and Caution Card.

### Signalmen.

Signalmen will properly record trains, beginning at 12.01 a. m., daily, on BLOCK REGISTER SHEET.

If a train is passed at any station it must be re-entered upon the Block Register Sheet.

The LAST train entering or leaving a block must be the last recorded.

In blocking trains the following code will govern :

\*“ B2 for \_\_\_\_\_ ” signifies “ Block all South or East-bound trains for \_\_\_\_\_ ”

\*“ B9 for \_\_\_\_\_ ” signifies “ Block all North or West-bound trains for \_\_\_\_\_ ”

If block is clear, a signalman, having received “ B2 for \_\_\_\_\_ ” or “ B9 for \_\_\_\_\_ , ” will first register the train upon his blank register sheet and then reply :

“ I I 13 B2 for \_\_\_\_\_ ” or “ I I 13 B9 for \_\_\_\_\_ , ” signing his initials and office call, and will block all opposing trains until the train so admitted has arrived and cleared the block ; if the block is not clear, he will reply : “ Block not Clear. ”

Upon the arrival of a train, the signalman will first execute any orders he may have, then ascertain from his Block Register if block is clear, but will not clear his signal until all orders concerning such train are satisfied, and block in advance is clear, and he has received “ 13 ” response, as per above code, from next block station in advance.

When there are no orders, and the block ahead is clear for an approaching train, the signal should be changed to “ Clear ” so that the train may enter without reducing speed. When the train has passed the block, and the signalman has seen the markers, he must display the “ Stop ” signal. When the rear of the train has passed 300 feet beyond the block signal, then he must give the train number and the time to the next block station in the rear.

(D) Operators will register in their train book arrival and departure of each train, also time signal displayed and time signal cleared.

\* While all roads do not use the same code, this is considered the best and most simple form.



CAUTION CARD.



.....Block Station.....190 .....

Card No.....Time.....M.

Conductor and Engineman, No.....

will proceed cautiously from.....

to.....expecting to find the last

.....bound train, No.....

that passed here at.....M.

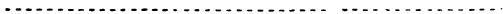

Signalman.

# RELEASE.

.....190.....

C. & E. No. ....

My Train Order Signal is displayed for No. ....

I have no orders for No. ....

Last train ahead left at.....M.

Or as per second clause of Block Rule .....

Instructions to Signalmen. Signalmen will fill out following :

Signal is displayed for No.....and No.....

to meet or pass at.....

except as above block is clear.

Issued at.....M.

.....Signalman.

NOTE.—When a block signal is at diagonal it only indicates that the block is clear to outer approaching switch of station ahead.

Should any train have orders not to pass a station without orders, the reception of this blank does not release it, but in such cases, regular orders must be obtained.

## CROSS-OVER PERMIT.

To Conductor.....Engineer.....

I have complied with rules. You may use.....

bound track at.....by protecting

your train as per rule (113).

.....  
Signalman.

This permit does not relieve train crew from any responsibility in connection with Time Schedule or Rules and Regulations.

---

**NOTE.**—When it is necessary for a train on a double track to cross to the opposite track, the Conductor shall, before crossing, notify the signalman at the Block Station where cross-over is located, and obtain permission to do so by the above blank.

## LESSON II.

**Blockwire Work.**

1. To get a *block* the operator would say: "B2 for No 3 Z."

B — Signifies block.

2 — Signifies east or south-bound trains.

No. 3 — Signifies the number of the train.

Z — The office call, wanting block.

Upon receiving this signal over the wire you would immediately display your danger signal and place the number of the train under [A] marked on attached sheet.

2. You would then acknowledge the announcement of this train, by replying: "I I 13 B2 for No 3 810 pm X"

I I — Has the meaning of aye, aye, or yes.

13 — Means "I hereby acknowledge receipt of and state that I fully understand and will execute."

B 2 — for No. 3 — As mentioned above.

810 — The time. See column [B].

X — Can be either the call for your office or your personal sign.

3. The first operator would next say: "No 3 By 812 Z."

By — Meaning the train had passed by station and entered the block for your station at 812.

You now enter the time just sent under column marked [C].

4. You would next get a block for this train from the office in advance, exactly the same way this office secured one from you. It will be given to you the same as you gave it to the office in the rear, unless the block ahead has been, or is about to be, entered by an opposing train, in which event both trains would meet at your station. But if given a block, note under column [D].

5. Following these points, you next enter upon your Block Sheet the "Arrival" of No. 3, and if you have secured a block ahead then you can enter time of "Departure," in case it is not necessary to stop train under columns [E] and [F].

6. After the markers have passed your station 300 feet, you report the train "By," stating the exact time to both the office in the rear and the one in advance as well as "OS'ing" the same to the dispatcher.

Note the signals carried, entering them under column "G" as: Green White or None.

7. This leaves but one column, time cleared block at station in advance, which is entered in column [H] when operator in advance reports train "By."

8. Same is applicable for [B9] for opposite direction.

### **Work.**

Make up a record of a train each way on your sheet.

"Z" will be the office on the east; "X" your own office, and "Br" the office on the west.





NOTE.—In asking for block on Specials, it is generally asked for in the conductor's name. Example: "B2 for Brown Spl."

## LESSON III.

### Block Examination and Answers.

Q. What is a block station?

A. A telegraph station with all necessary signals for blocking trains.

Q. What is a block?

A. A block is the distance between the outer approaching switches of two block stations.

Q. What is a positive block?

A. A block where only one train is allowed at a time.

Q. What is a cautionary or permissive block?

A. A block whereon two or more trains are allowed by the use of a cautionary card or signal.

Q. Are block stations for any other use or purpose than blocking trains?

A. They may be used for stopping trains for telegraphic orders.

Q. What rules besides block signal rules apply to them?

A. Train order rules.

Q. Which arm or light governs the train approaching a block signal?

A. The right hand arm or light facing the train.

Q. What is a block signal?



A. A semaphore where arms govern by day; and red, green, and white lights by night.

Q. What does the horizontal position of arm signify?

A. Danger. Stop.

Q. By what name shall the horizontal position of arm or red lights be known?

A. Danger Stop. STOP SIGNAL.

Q. By what name shall the diagonal position of the arm or green lights be known?

A. Clear. Proceed.

Q. When a clear signal is given, how far does it indicate that the block is clear?

A. To the outer approaching switch ahead.

Q. What is meant by the outer approaching switch of a station?

A. The first switch a train meets upon approaching a station.

Q. At what position must signals always be kept except when changed to allow a train to pass?

A. Horizontal or danger.

Q. While you have train orders on hand, at what position must signals always be kept?

A. Horizontal or danger.

Q. What must be done before issuing clearance cards to trains to which you have delivered orders?

A. Ascertain that there are no more orders and that the block is clear.

Q. If you have no orders for a train and block ahead is clear, when should you give clear signal to the approaching train?

A. As early as possible in order that they may not reduce speed.

Q. When is the proper time to report a train clear of a block ?

A. Three hundred feet past the station.

Q. When is the proper time to replace a danger signal after a train has passed ?

A. Immediately after the markers have passed your station.

Q. How are you to know when an entire train has passed ?

A. By the markers.

Q. What are markers ?

A. Red lights by night and green flags by day on rear of train.

Q. If a train passed without markers what would you infer and what action would you take ?

A. Notify stations on each side and report to the train dispatcher that the train had parted.

Q. If you are notified by block station in either direction that a train which had entered the block had parted, what would you do ?

A. Give *train parted signal* to engineman as train approached.

Q. What is "train parted" signal ?

A. A lamp or flag swung in a circle at arm's length across the track.

Q. When is a cautionary Block Signal or CARD used ?

A. When dispatcher desires a train to enter a block which is not clear.

Q. By whose authority can such a card or signal be used ?

A. That of the train dispatcher.

Q. How must such card be endorsed by train dispatcher, before it becomes of force or value ?

A. He must give number of card, Ok, time, and Sig.

Q. Do you understand that when a caution card is used a release must also be issued ? If so, why must release card be issued ?

A. To release the train and show that there are no orders for it.

Q. After a train has received orders at your station what should you do to release the train from your signal ?

A. Stamp orders "Block is Clear."

Q. Suppose that two or more sections of a train were to meet an opposing train at your station, would you give the opposing train a clear signal before all the sections had passed and all orders on hand had been completed and delivered or canceled, or while there was another train in the block ?

A. No.

Q. Will you change your block signal to "clear" under any circumstances until all orders on hand are completed and delivered or canceled, or while there is a train in the block ?

A. No.

Q. What record of trains must be kept and what time must be kept ?

A. Leaving time of trains in advance and rear,

signals carried and time of arrival and departure of trains at your station.

Q. If a train is passed at your station by another train, what record is made of train on siding?

A. It is re-entered on register.

Q. What train must be last recorded on your train sheet?

A. The last one to depart.

Q. How are trains to be reported?

A. To offices both in advance and rear.

Q. What does signal "B" signify?

A. Block.

Q. State fully what a signalman is required to do when he receives order to "B2" or "B9" for a train.

A. If no train has entered the block give "B2" or "B9" and allow no train to enter until block is cleared.

Q. What must be done with approaching train if a train from opposite direction has entered the block?

A. Display danger signal to hold the approaching train or stop it.

Q. What must be done upon the approach of a north or west-bound train?

A. Get "B2" or stop it.

Q. What must be done upon the approach of a south or east-bound train?

A. Get "B9."

Q. What would you do in case you could not raise next block station to get him to block trains,

and could not raise dispatcher to get instructions?

A. Issue a caution card stating the facts of the case. Then trains can only proceed in accordance with the schedule.

Q. Under what conditions may a train be allowed to enter a block before a preceding train has cleared that block?

A. Under cautionary card or signal.

Q. How must your signals be displayed when trains are to meet at your station?

A. They should be held at "danger" until one train is in the clear.

Q. At stations on a double track, what is the signalman's duty upon the approach of a train?

A. If block is clear and no orders, turn signal to "Clear."

Q. When one track is obstructed and by direction of train dispatcher a single track is used, by what rules will signalman be governed?

A. Single track rules.

Q. What must be done to allow trains to proceed when they have orders to meet at a non-telegraph station or intermediate siding?

A. Trains must be stopped and given a release with second clause.

Q. Under what circumstances would you leave signals at "Stop" position, and deliver caution card in addition to release card?

A. At "Stop" no caution card is needed.

Q. When trains receive orders to meet at a closed block station or non-telegraph station, how would they be permitted to enter the block?

A. By use of caution card.

Q. What do you do in operating a positive block between two open block stations where there is an intermediate non-telegraph station ?

A. Ignore it.

Q. What must be done in case a train is to use a cross-over switch or enter the opposite or wrong going track ?

A. The conductor must notify the operator at the station last passed of his intentions, which operator will notify the operator in the block station in advance, who will use the danger or cautionary signals for all opposing trains, until that train which has crossed over has reached his or another block station on the right track.

Q. What is the duty of the first signalman ?

A. Get "B2" or "B9" if block is clear

Q. What is the duty of the second signalman ?

A. Give "B2" or "B9" if block is clear.

Q. How many copies of caution card must be issued to one train ? And to whom to be given ?

A. Two. Given to the conductor.

Q. If a train enters a siding at your station to be met or passed by another train, what must you know before reporting block clear ?

A. That the train is in the clear and that the switch is closed.

Q. When it is necessary for a train which you have reported as in the clear to back into block, what will you do ?

A. Get block from station in the rear.

Q. If it should be necessary to stop a train

while passing your station for which you had given a clear signal or caution signal, what signals would you use ?

A. Danger signals, also hand signals.

Q. After train has passed your office and you are offered an order for or are ordered to block that train, what would you do ?

A. Refuse it by stating the circumstances, and then try to stop train.

Q. When should night signals be displayed ?

A. From one hour before sunset until one hour after sunrise.

Q. What must be done before closing a block station ?

A. Get relief from train dispatcher and notify offices on each side.

Q. When block stations are closed what must be done with signals ?

A. Leave them at "clear."

Q. What must be done with block wire ?

A. It must be cut through to stations on each side.

Q. How is this done ?

A. By the use of the switch-board.

Q. What must be done when office is re-opened ?

A. Turn signal to "stop," report to train dispatcher for duty, and notify offices on each side.

Q. What must be done before allowing the first train to pass ?

A. Ascertain if block is "clear."

Q. What signals must signalmen provide themselves with ?

A. Red, green, and white flags ; red, green, and white lanterns ; fuses and torpedoes.

Q. When should hand signals be used ?

A. Any time when the proper indications can not be given by the fixed signals.

Q. If a train has passed your station and stops and takes siding, how do you treat such train ?

A. Treat it as an approaching train.

Q. What do you do when a train crosses over, and what rules do you follow ?

A. Issue a cross-over permit and operate a positive block until train returns to the proper track.

Q. Should a car or a portion of a train run back in the wrong direction, what must you do ?

A. Notify signalman toward whom the car or portion of the train has gone.

Q. What is the duty of the signalman receiving notice ?

A. Must turn signal to "stop" and allow no train to enter block until such car or portion of train has been stopped.

Q. What is the duty of signalman in advance ?

A. He must give "train parted" signal to engineman approaching.

Q. If you are ordered to block a train which is passing, what is done ?

A. Give hand signals until you are able to communicate with the conductor.

Q. What code is used on single track in operating trains between blocks ?

A. "B2" to block all east or north-bound



trains. "B9" to block all west or south-bound trains.

NOTE.—Never allow more than one train at a time in a block except by caution card or a special train order. Do not report a train clear of a block until you have *personally* seen the "markers" pass. To see the cabooses is not sufficient. There may be two or more cabooses, and the last one may break off.

Q. For what trains are block signals used to control their movements?

A. Those on the main track.

Q. Can they be accepted by trains on the side-tracks?

A. No.

Q. What must every train have, arriving at a block station where block is at STOP before proceeding?

A. Proper authority must be obtained from signalman.

Q. Of what does proper authority consist?

A. (a) caution card and release; (b) a release stamped BLOCK IS CLEAR; (c) train orders stamped BLOCK IS CLEAR; (d) or train orders and caution cards.

Q. What must all trains occupying side-tracks, or trains starting from terminal stations, have before proceeding?

A. Proper authority of either (a, b, c, d).

Q. If signalman is called upon for block, and if the block is not clear, how will he answer?

A. "Block not clear."

Q. If a train entered a siding, what notice should the signalman receive before reporting the block clear ?

A. That it is clear of the main track and switches are locked.

Q. Can a signalman accept an order to hold a train for orders or to block them if the engine has once passed the signal and they are at a stand-still ?

A. Not until he has communicated with the conductor.

Q. What must the signalman first obtain for trains which he has admitted to the block in either direction before closing the block switch ?

A. "3."

Q. What is the "home block signal" ?

A. A fixed signal at the entrance of a block to control trains in entering and using said block.

Q. What is the "distant signal" ?

A. A fixed signal used in connection with a home signal to indicate that the home signal may be at STOP when the distant signal is at "Caution"; or, that the home signal is clear when the distant signal is clear.

Q. What is the "advance block signal" ?

A. A fixed signal used in connection with a home block signal to subdivide the block in advance.

Q. What is the meaning of block system ?

A. A series of consecutive blocks.

Q. What is the meaning of "telegraph block system" ?

A. A block system in which the signals are operated manually, upon information by telegraph.

Q. What is the meaning of "Controlled manual block system"?

A. A block system in which the signals are operated manually, and so constructed as to require the co-operation of the signalmen at both ends of the block to display a clear signal.

Q. What is the meaning of "automatic block system"?

A. A block system in which the signals are operated by electric, pneumatic, or other agencies actuated by train, or by certain conditions affecting the use of a block.

**“31—X’—Order,” Retaining “13” Order  
Feature.**

**Central Railroad Company.**

TRAIN ORDER NO. 66

*July 28* 190    

To C & E No 11 At Logan Station

To \_\_\_\_\_

“X” Meyer Opr. 830 a M.

TRAIN AHEAD LEFT AT 720 a M.

*No Eleven 11 Eng 66 Jones will meet No twelve  
12 Eng 75 at Missouri Valley*

12 R. A.

CONDUCTOR AND ENGINEMAN MUST BOTH HAVE COPY OF THIS ORDER.

*Repeated at* 832 a M.

CONDUCTOR	TRAIN	MADE	TIME	OPERATOR
<i>Jones</i>	<i>11</i>	<i>O K</i>	<i>833 a</i>	<i>Meyer</i>
			<i>J B D</i>	

## PART VII.

### LESSON I.

#### Technical Orders.

##### Explanations.

##### Notes on "31"—"X"—"13" Orders.

*Trains When Extras—How Designated.*—Extra trains are designated by Engine numbers, Conductors' names, as —

Extra 678 Jones,  
with the direction as NORTH, SOUTH, EAST, or WEST.

*Time.* — Time in the body of the orders must be written in words and duplicated in figures, thus —

Nine thirty three 933 A. M.

*Figures.* — Figures must not be surrounded by brackets, circles, or other characters, but must appear plainly without accompanying marks.

*Signal "31."* — To transmit an order, the signal 31 must be given to each office addressed, the number of copies being stated. Example :

"31" Copy —

*Transmission of Orders.* — A train order to be sent to two or more offices must be transmitted

SIMULTANEOUSLY to as many of them as practicable. The several addresses must be in the order of the superiority of trains, *each office taking its proper address*. When not sent simultaneously to all, the order must be sent first to the superior train. Each office is enabled to copy its proper address by hearing the dispatcher give its office call just preceding the address of its train and immediately after it, the superior train being addressed first. Example: To A to C & E No 12 A.

To B to C & E No 11 B.

*Meeting Points.* — When a meeting point is to be made between two trains at a certain station, the order, when practicable, should be sent to said trains to stations either side of the actual meeting point; also to the operator at the actual meeting point, if a telegraph office. Example:

To A to C & E No 8 A.

To B to C & E No 7 B.

To C to Operator. C.

In issuing an order to a train at an actual meeting point, the body of the order will state that it is put out at said meeting point, thus:

“No sixty six 66 gets this order at the meeting point.”

*Abbreviation “12.”* — The numeral abbreviation “12” will be used at the end of a train order immediately preceding the signature of the dispatcher. Example: [Sig] “12 E. M. D.”

“12” signifies: “Do you acknowledge receipt of this order, and do you fully understand it?”

*Abbreviation “13.”* — In responding to train

orders, conductors or others use the abbreviation "13," which the operator sends just preceding the signature, after an order has been repeated and signed by parties to whom it is addressed. "13" signifies: "I hereby acknowledge the receipt of the order and state that I fully understand it and will execute it."

*Repeating Orders.*—When a train order has been transmitted operators must first give "X" response [unless otherwise directed], and repeat order at once from the manifold copy in the succession in which the several offices have been addressed, and THEN write the time of the repetition on the order, thus:

Repeated at "220 pm"

Each operator receiving the order should observe whether the others repeat it correctly or exactly as he himself has it.

Those to whom the order is addressed, except enginemen, must read it aloud, then sign it. The operator will send their signatures, preceded by the number of the order and "13," to the train dispatcher, thus:

"Order No 3 sig 13 Brown."

The response "OK" and the TIME, with *his* initials, will then be given by the train dispatcher. Example:

"Order No 3 OK 223 pm. HDG."

Each operator receiving this response will then write on each copy "OK" [in this case meaning "COMPLETE"], the TIME, train dispatcher's

initials, and his own last name in full, and deliver a copy to each person addressed, except enginemen.

“X” *Response*.—A train order must be acknowledged by the operator responding: “X [number of train order] to [train number],” with the operator’s initials and the office signal. The operator must then write on the order in the places provided for that purpose, his initials and the time. Example of “X” ing an order :

“X Order No 3 to C & E No 1 J. B. H. DS.”

“X” signifies: “I have displayed my train order signal and hereby acknowledge the receipt of the order, and pledge myself to hold the train [or trains], and when OK response is received, to deliver.”

NOTES.—“OK” must not be given to a train order for delivery to an inferior train until “X” response has been sent by the operator who receives the order for the superior train.

Where trains stop for orders, which have not been received, or when for any reason the operator calls for orders, he will secure the circuit and attract the dispatcher’s attention by using the signal “19.”

Conductors’ names are given in all, or nearly all, of the orders of this kind. Example orders :

“No one 1 Eng 77 Jones will meet No four 4 Eng 88 Smith at Vinton.”

“Eng 33 Brown will display signals and run as first No eleven 11 New York to Hudson.”

“Hold No twenty two 22 Eng 876, Benson at Lake City.”





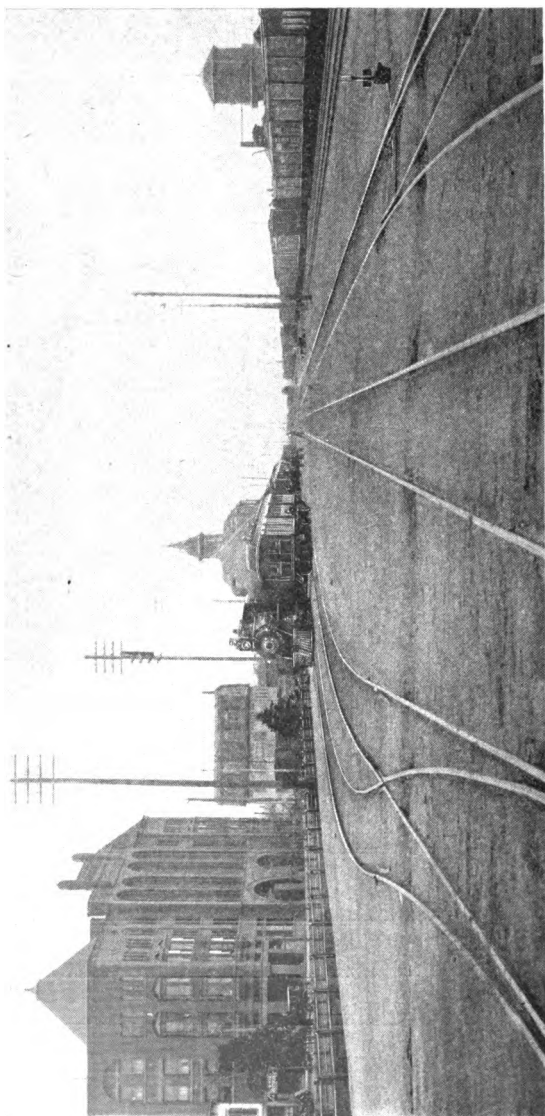

Division point. A lucrative position for an advanced operator.

## LESSON II.

### Technical Messages.

#### Telegraphic Report Called the "Soup Ticket."

*Mc Ville* Station *2-11* 19.....

Train No. *Spl* Engine No. *886*.....

Arr. .... M. Dep. .... M.

**LOADS.**

**EMPTIES**

**PASSENGER.**

Stock *30* N.W. .... Mail and Baggage.....

Time Freights Foreigns ..... Coaches *1050 p m*.....

D Freights *793 tons* Sleepers.....

*Wilbur* ..... Conductor.

## The "Detail" Train Report.

To the Train Dispatcher :

Vinton 2-11

19

 Train *Spl* Left *Vi 840 p* M. Engine *886*

 Engineer *E. J. Moore* Conductor *Wilbur*

### LOADS.

 Give contents and destination of each load and state when carded, or Time Freight.  
 Give route of Eastern Time Freight.

No. Lds.	CONTENTS.	DESTINATION.	TIME.	ROUTE.	Tonnage.
<i>14</i>	<i>Cattle</i>	<i>U. S. Yds</i>			<i>396</i>
<i>11</i>	<i>Hogs</i>	" "			<i>281</i>
<i>2</i>	"	<i>Wood St</i>			<i>50</i>
<i>2</i>	"	<i>Chgo</i>			<i>50</i>
<i>1</i>	<i>Horse</i>	<i>Mc Ville</i>			<i>16</i>
<i>30</i>					<i>793</i>

### EMPTIES.

Give Initials, Kind of Cars, Destination, and Size of Local Box and Stk.

No. Mts.	INITIALS.	KIND.	DESTINATION.	SIZE.	Tonnage.

*Wilbur*

Cond'r or Agent

Soup tickets derive their name from nobody knows where, but as they are invariably so called, it is not our intention to try to change it. They are filled out by conductors and generally asked for by dispatchers. The foregoing should be sent as follows :

Hr Soup Tkt Fm McVile 11

Train Spl Eng 886 [.] [.] Loads 30 Total 793  
Tons sig Wilbur.

Detail messages are started the same as Soup Tickets, adding the engineer's name. It should be sent directly across the page, as the receiver has a specified form upon which to receive it. By making a period [.] at the end of each line the receiver knows when to begin under "No. Loads" again. Example :

14 Cattle U S Yards 396 [.]

11 Hogs U S Yards 281 [.]

Where both loads and empties are filled out, they should be announced as "Loads" just preceding the first part, and "Empties" after it had been completed, and the final part ended with the word "Sig" with either the Conductor or Agent's name.

# TELEGRAPHIC REPORT CALLED THE "SOUP TICKET"

..... Station ..... 19.....

Train No..... Engine No.....

Arr..... M. Dep..... M.

**LOADS.                    EMPTIES.                    PASSENGERS.**

Stock..... N.-W..... Mail  
and Baggage.....

Time  
Freights..... Foreigns..... Coaches .....

D Freights ..... Sleepers .....

..... Conductor.

## The "Detail" or Destination Train Report.

To the Train Dispatcher :

C D 2-12 \_\_\_\_\_ 19\_\_

Train 33 Left 840 a M. Engine 356

Engineer Carroll Conductor Brown

### LOADS.

Give contents and destination of each load and state when carded, or Time Freight.  
Give route of Eastern Time Freight.

No. Lds.	CONTENTS.	DESTINATION.	TIME.	ROUTE.	Tonnage.
3	Co Coal	Sterling		UP Trfs	164
6	Rails	Mo Valley			270
1	Rails	West Side			40
2	Apples	Omaha		UP Trfs	25

### EMPTIES.

Give Initials, Kind of Cars, Destination, and Size of Local Box and Stk.

No. Mts.	INITIALS.	KIND.	DESTINATION.	SIZE.	Tonnage.
7	C & N W	Spl	Mo Valley		163
3	C R Q & P	Box	Omaha		41
2	C & N W	Coal	Soo City		78
5	U P	Cx	Omaha		25
2	L S & M S	Spl	Denison		22
1	Star U	Refr	So Omaha		18
					716

F C Stuard

Cond'r or Agent.

## LESSON III.

### Car Reports.

#### Practical Hints.

In sending this report, announce it to the dispatcher as "cars," signing your office call, and then





send the letter over such parts of the report as you happen to need to fill out. Example :

A 1 B 2 F 2 G 2 K 1 O 1 C B & Q P 5, and so on all through the report. These reports differ in style, but are all more or less under the same heading and rules.

Received From	Time Received	Sent by	Received by
---------------	---------------	---------	-------------

From McC Viller Feb 7-1902  
 To E.M.D. Boone  
 Order No. 25 Time filed 1043 am M.

- A. Cars wanted (number) one
- B. Initials Behrten
- C. Class of cars wanted Horse with <sup>16</sup> Stalls
- D. Size of cars wanted \_\_\_\_\_
- E. Where wanted Mechanicsville
- F. Date wanted Feb 9<sup>th</sup>
- G. To be loaded with Horses
- H. Destination Buffalo - N.Y.
- J. How routed P.M.S.

Signed: W Edwards

**Telegraphic Order Form.**

Address Car Service Agent for special equipment. Orders for common equipment and foreign are to be placed with the Train Dispatcher.

Received From	Time Received	Sent By	Received By
<i>W</i>	<i>1055 a</i>	<i>D E</i>	<i>A N</i>

From *West Liberty Iowa Feb 10*

To *J B S Des Moines*

Order No. *22* Time Filed *1040 a* M

A. Cars Wanted (Number) *One*

B. Initials *A M S*

C. Class of Cars wanted *Palace Horse*

D. Size of Cars wanted *50 ft*

E. Where wanted *West Liberty*

F. Date wanted *Feb 17th*

G. To be loaded with *Horses*

H. Destination *Jefferson Mass*

J. How routed *L. S. & M. S.*

Signed: *J B Smith*

NOTE.—In the foregoing message it would usually be announced to the dispatcher by the Form Number, or as “Spl Equipment” report.

Having made the necessary announcement, the sending operator would in most cases begin the message with his office call, his personal signal, and then say: “Fm” West Liberty Ia 10 “to” J. B. S., Des Moines Ia. [.]

Order No. 22 [.] [.]

A One [.]

B Ams.

C Palace Horse.

D 50 ft.

E West Liberty.

F Feby 17th.

G Horse.

H Jefferson Mass.

J L S & M S.

Sig. J. B. Smith.

The receiving operator having a similar form, simply fills out the blank lines after each cipher letter is announced. The object is to save time and keep things at all times in a systematic form.

### **Practical Hints for Railway Telegraphers.**

In case of accident upon the road, see that no information or account of the same is given to any but those connected with the management, and neither ask nor answer questions by wire or otherwise, except from or to the train dispatcher or other officers of the company. Do not converse about the accident in any way.

Do not depend upon others to do your work, and do not meddle with other employes' work.

Place yourself on record from the very beginning as a man whose statements can be relied upon. In your correspondence with your superior officers use diplomacy in your language. Construct your letters in such a manner that there will be no unnecessary correspondence, and make them short and to the point, but above all things make them clear.

Look up and down a track before stepping between the rails. Make a practice of doing this, even if you are sure that there is not a train or engine moving within two miles of you. It is an excellent habit to acquire. Practice this, and almost unconsciously you will form the habit, invaluable to a railway telegrapher, of exercising great caution before placing himself in positions of danger.

Do not lose your temper, and take it out on some operator along the line. Do not comment on the company's way of doing business. The dispatcher hears all that goes over the wires, and he is in a position to retard your promotion or help you along toward promotion.

Do your telegraphing while on duty, study it while off duty. Always try to be accommodating, unassuming, and quiet. Help old people on and off trains. Do not get out of patience if a traveling man asks a small favor. They often travel all night, put up at poor hotels, and feel out of sorts, but a good word from them circulated among other traveling men, will reach the officials' ears more often than in any other way.

## PART VIII.

### LESSON I.

#### Advanced Commercial Work.

*Black.* — A day message which should be delivered immediately. The phrase “black” is used only to announce that day messages follow when the sender has been sending night or Reds, as they are termed, or other classes. Example :

[ Hr black ] DS MK.— [ Ck ] 9 Paid.

[ Fm ] Des Moines Iowa Feb 22nd, 1902.

[ To ] H. H. Brown,

Bijou [ . ]

Philadelphia Penn.

[ . ] Offer you forty dollars per week and expenses answer.

[ Sig ] H. T. Jones.

“ 415 p.m.”

---

#### A Message Requiring Special Delivery.

NOTE.—A message to be delivered beyond the free delivery limits of the terminal office, and for which the delivery charge is not given in the Tariff Book, will be accepted upon the payment of guarantee of an amount sufficient to cover the message tolls and the probable cost of delivery. The words :

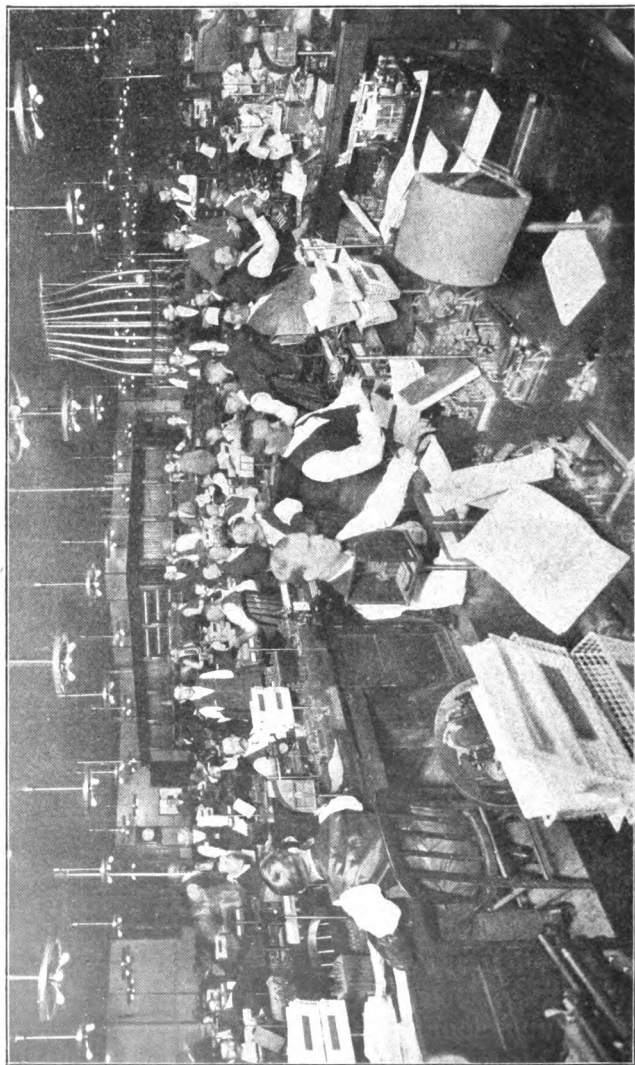

Interior of Postal Telegraph Cable Co. operating room, Chicago office.

“Deliver and report charges,” when the charges are to be paid by the sender, or the words: “Delivery Charges Guaranteed,” when they are to be paid by the addressee, will be inserted in the check of such message, and will be counted and charged for.

Example message :

127 NY. DB.— [ Ck ] 10 Paid 3 ex wds.

Dely Chgs Gtd.

[ Fm ] New York N. Y. Feb 11th, 1902.

[ To ] E. J. Snyder,

3 1-2 Miles North,

Lafayette, Ind.

[ . ] Your son killed this afternoon wire instructions.

[ Sig ] E. H. Ankeny,

Coroner.

“5:15 p.m.”

NOTE.—In the check of this message we have three extra words, while in the body there are only seven. The object in placing these three extra words after the *check*, instead of the body, is to call the attention of the receiving office to the fact that the charges are guaranteed. Were they placed in the body of the message, they might confuse the recipient of the message, and also miss the attention of the delivery clerk.

Where the sender of a message either does not know that the message goes beyond the free delivery limit, or when he neglects to notify the sending office, or to make note in address, it results in a series of Office or Service messages of this kind :

**Asking for a Guarantee on a Message.**

To Cincinnati Ohio.

Yours date Brown signed Beaver undelivered party lives six miles in country. Do you Gte dely chgs.

Morris, Ills. 23rd

---

**Guaranteed Delivery Charges.**

To Morris, Ills.

S. Y. S. Ours date Brown signed Beaver Delivery Charges Gtd. Rush delivery.

Cincinnati, Ohio. Feb 23rd—

---

**When Delivery Charges are not Guaranteed.**

To Morris, Ills.

S. Y. S. [See your service] ours date Brown signed Beaver. Please drop in Post Office. Delivery Charges not guaranteed.

Cincinnati, Ohio Feb 23rd—

---

**A Government Message.**

*Government*—A message demanding special or government rates, and taking precedence over all ordinary business. It relates to official government business. Example:

[Hr Pink Govt] 323 WN FG. — [Ck] 18 Paid Govt.

[Fm] Washington, D. C. "Dec" 12th—"02"

[To] Observer,

Chicago, Ills.

[.] For Illinois generally fair except in extreme western portion lower temperature Wednesday, warmer Thursday.

[Sig] Moore

"3:25 p. m."



NOTE. — In all government messages to count for Check you begin at “To” and count everything including the signature. [Tariff books give rates.]

---

**A Deadhead Message.**

*Deadhead* [or *D. H.*] — Where a message is sent free and no tolls collected for its transmission or delivery. The check of a free message will show the reason for its acceptance without tolls.

Remarks: Example —

- 10 D. H. Frank No.....
- 10 D. H. Employe.....
- 10 D. H. Answer to D. H.....
- 10 D. H. No..... and paid via.....
- 10 D. H. Company.....
- 10 D. H. Frank No..... and Frank No.....

[When free over two lines.]

---

[Hr No] 39 C. MK. “HO” [Ck] 8 D. H. Company.  
 [Fm] Cleveland Ohio, “Nov” 12th—“02”  
 [To] Carl Brown [.]

*Try Hotels.*

*Cincinnati, Ohio*

[.] *Report to Manager Moffitt at once for duty.*

[Sig] *F. H. Stubbs,*

*Supt.*

“1010 a. m.”

---

WORK. — Make up six Deadhead Messages, using each of the above reasons.

**Grain Message.**

*Grain.* — Pertaining to transfer of grain or provisions, speculative or otherwise. Example:

[hr Grain No] 330 M. NB. MK. 4 Paid.

[Fm] Omaha, Nebr 23rd.

[To] Bartlett Frazier & Co,

No 233 Wabash Ave,

Chicago, Ills.

[. ] Buy ten May wheat.

[Sig] Tom Kelly.

“9:30 a. m.”

NOTE. — Assuming that the number in the address had been sent wrong, a service message of this kind should be sent:

**Where No Such Number.**

To Omaha, Nebr.

N. S. N. [no such number] as 233 Wabash Ave  
G. B. A. or cant 92 yours date Bartlett Frazier & Co  
signed Kelly. Cant find.

Chicago, Ills. 23rd.

**LESSON II.****Other Series.****Wrong Address.**

To New York.

Yours 24th White 1312 Worthington Avenue  
Sgd Brainerd Undeld party unknown at that number  
cant find.

Chicago, Ills. 25th

**Correcting Address.**

To Chicago, Ills.

S. Y. S. Ours 24th White sgd Brainerd is addressed 1512 Worthington Avenue, not 1312 as you have it. Can you 92 now?

New York N. Y. 25th—

**Meaning of "Relay" and "Through."**

*Through*—Called "Tru" on the wire, is a message *relayed* by several offices or one office from its originating point to its final destination. A message to some other point than the first office copying it is a "Tru" message, also.

Example:

[Chicago's Received "Tru" copy]

[Hr tru No] 173 ND. PZ MK. 13 Collect.

Indianapolis, Ind., Feb 24th—"02"

Cline Bros.

Harlan, Idaho.

Wire lowest price on two narrow tread wagons and five maxine plows.

Jones Bros.

"5:12 p. m."

[RN. 517 P. M. MK. DW.]

After a message has been sent it must ALWAYS BE "TIMED" in the following form: First, the call of the office to which it is being sent. Second, the time of transmission. Third, the operator's signal sending. Fourth, the receiving operator's signal.

Assuming that the office at Harlan, Idaho, was closed for the night and that the message lay over at Chicago, Ills., Chicago would send the following service in case message was considered important :

**Delayed Series.**

To Indianapolis, Ind.

We hold until 8 a. m. yours date Cline Bros sgd Jones Bros. Office closed for the night at Harlan Idaho.

Chicago, Ills 24th

---

Assuming that Cline Bros. refuse the payment on this next morning, Harlan would send a Service message of this kind. Example :

**Uncollect.**

To Indianapolis, Ind.

Collect there yours 24th Cline Bros sgd Jones Bros. Payment refused.

Harlan Idaho 25

---

**Request to Report Delivery.**

If the sender of a message requests a notice of its delivery, insert in the check the words, "report delivery." Instructions from the sending office will be carefully carried out.

*City.* — Where a message reaches its destination it is called a "City." The term was universally employed when common white clip paper was used for through or relayed messages, and the yellow or city blank, as it is known, was used for the city

copy ; but this has almost been done away with, and all city copies as well as "tru's" are copied on the same blank in the cities. This new method saves time and labor.

---

[*hr city*] *PO. BG MK*

*8 Paid 2 ex wds Report Delivery.  
Clinton Iowa "Feb" 17th, "02"*

*J. V. Martelle,*

*Actor formerly with Empire Stock Co,  
Try Hotels and Theaters,  
Denver Colo.*

*Can sign you for season                      answer.*

*Bennett & Co*

*Booking Agents.*

*6:55 p. m.*

---

Denver would act as requested in the check and if delivered or not delivered report the facts of the case. If delivered the message would read :

[To] *Clinton Iowa.*

*Yours this date Martelle sgd Bennett & Co deld  
O K 655 p. m.*

*Denver Colo 12th,*

---

NOTE. — You will notice that considerable stress is put on the address, and seemingly so much that extra words appear to be used, but where it is necessary to mention a point to insure delivery, it is much better to make a lengthy address, insuring

clearness, than to necessitate sending several service messages.

**Other Form of "Asking about Delivery."**

[To] *Monmouth Illinois.*

*Show delivery ours 20th Cornell sgd Brandon.  
Sender claims Non-delivery.*

*Galveston Texas 21st, 19*

**Code and Cipher Messages**

Are messages containing either words without meaning, uncommon words, or words making a line without sense, or a group of letters termed a word, to secure secrecy and economy. Sometimes they are announced on wire as "Code," so that the receiving operator will be on his guard. This is done only in small offices, however.

**Code Message with Extra Words.**

*273 CH. NE MB.*

*8 Paid 3 ex wds*

*Peoria, Ills Feb 12th, 19*

*Sinclair & Co,*

*Cedar Rapids, Iowa.*

*Inletting capsula carvine lub sudgore.*

*A. Carter,*

*General Agent, The Merchants Dispatch*

*605 p. m.*

NOTE.—In this message we have three extra words. Of course it is understood that all code messages do not have title words or extra words.

In the signature of a message, the sender is allowed two title words free; beyond that all others are counted as extra words.

Assuming that this message was not understood, or that the Sinclair Co. believed that an error was made in transmission, they would say: "We want that message REPEATED," or send for "DUPLICATE," and the Cedar Rapids office would send a message as follows:

To Peoria, Ills.

Duplicate quick yours this date Sinclair Co sgd  
Carter not understood.

Cedar Rapids, Iowa 12th

NOTE. — The second copy or duplicate will bear the word "Duplicate" immediately after the check, so it will not be mistaken for another message.

#### **Duplicate Transmission [Rule 36].**

If, to correct an error in a message, or for any other reason, a second transmission becomes necessary, the sending operator will begin the second transmission with the word "Duplicate," which the receiving operator **MUST** write conspicuously on the message.

---

#### **Asking Duplicate for a Certain Word.**

To Philadelphia, Penn.

Duplicate third word yours date Smith sgd  
Brown reaches us BEANERY. claim should be  
"Beaning."

Chattanooga Tenn 22nd

**Correcting the Word.**

To Chattanooga Tenn.

S. Y. S. third body word ours date Smith sgd Brown should read "beaning," we repeat beaning not "beanery" as you have it.

Philadelphia Penn 22nd

---

**Night or Red Messages**

Are so called because they are sent at reduced rates, and delivery does not occur on them until the morning following from date. The word "Red" is used to announce a night message on the wire, as operators are required to copy them on blanks printed in red ink. ALWAYS begin your night messages with word RED, and also send word NIGHT after check. Night messages are to be *sent* as far as possible on day of date. An office which is not kept open will, before closing, transmit its "night" messages to their destination or nearest relay office. If any night messages are left over until morning, they will be transmitted before new business is taken up.



**NIGHT MESSAGE.**

---

[*hr Red No*]      66 De NB MH      3 Paid Night [*?* Nite]

*Detroit, Mich Feb 22nd—19*

*Carson Bros*

*Winterset, Illinois.*

*Goods shipped today*

*Cole & Sons Ltd*

*310 p. m.*

## LESSON III.

**Forwarding Messages.**

When a message which is to be forwarded is a "received collect" message the forwarding office will check it so that the tariff from that office to its destination shall appear in the check as "this" line tolls, and the tariff from the originating office to the forwarding office as "other" line tolls.

REMARKS.— Suppose the tariff from Buffalo to Boston to be 35 and 2, and from Boston to River Falls 25 and 2, and a ten-word message has been sent "*collect*" by Buffalo to Boston, which the latter office is to forward to River Falls. Boston should check the message [counting 4 extra words] 16 collect 35 and 35. The "35" [tariff from Boston to River Falls] represents the tolls for fifteen words on the forwarded message, and the other "35" [tariff from Buffalo to Boston] represents the tolls for ten words which should be mentioned first.

## The Three Stages in a Message When Forwarded.

[First Received Copy.]

FORM NO. 1.

### Commercial Telegraph Company,

This Company **Transmits** and **Delivers** messages only on conditions which have been assented to by the sender of the following message.

Errors can be guarded against only by repeating a message back to the sending station for comparison, and the Company will not hold itself liable for errors or delays in transmission or delivery of **Unrepeated Messages**. This is an **Unrepeated Message**, and is delivered by request of the sender under the conditions named above.

745 Br NJ MK 11 Collect

Buffalo N Y "Feb" 23rd "1902"

To J M Bradley

Transient,

Boston Mass.

Meet me at Chicago Monday morning nine o'clock Palmer House.

Herman Cook

7:10 p. m.

Assuming that Mr. Bradley had left Boston before the message had been received, and had left orders to have it forwarded to River Falls, Boston would mark out certain lines in the message and add others, as per example:

FORM NO. 1.

## Commercial Telegraph Company,

This Company Transmits and Delivers messages only on conditions which have been assented to by the sender of the following message.

Errors can be guarded against only by repeating a message back to the sending station for comparison, and the Company will not hold itself liable for errors or delays in transmission or delivery of **Unrepeated Messages**.

This is an **Unrepeated Message**, and is delivered by request of the sender under the conditions named above.

M

10:10 pm

16

35 &amp; 35 cts 4 ex wds

~~745 BN NJ MK~~

## Collect

Buffalo N. Y. 23 Via Boston Mass 23

To J. M. Bradley

Transient,

~~Boston Mass~~ River Falls, Mass.

Meet me at Chicago Monday morning nine oclock Palmer House.

Herman Cook

~~2-10 p.m.~~

[River Falls' Received Copy.]

FORM NO. 1.

## Commercial Telegraph Company,

This Company Transmits and Delivers messages only on conditions which have been assented to by the sender of the following message. Errors can be guarded against only by repeating a message back to the sending station for comparison, and the Company will not hold itself liable for errors or delays in transmission or delivery of **Unrepeated Messages**. This is an **Unrepeated Message**, and is delivered by request of the sender under the conditions named above.

B NV. JH.

16 Collect 35 & 35 cts 4 ex wds.

Buffalo N. Y. 23 Via Boston, Mass "Feb" 23 "1902"

To J M Bradley

Transient

River Falls, Mass.

Meet me at Chicago Monday morning nine o'clock Palmer House.

Herman Cook

"920 P. M."

## Extra Date and Other Line Message.

[Chicago's Received Copy.]

FORM NO. 1.

### Commercial Telegraph Company,

This Company **Transmits and Delivers** messages only on conditions which have been assented to by the sender of the following message.

Errors can be guarded against only by repeating a message back to the sending station for comparison, and the Company will not hold itself liable for errors or delays in transmission or delivery of **Unrepeated Messages**.

This is an **Unrepeated Message**, and is delivered by request of the sender under the conditions named above.

88 DS MK. PZ 9 Collect 25 & 25

*Tripoli, Iowa 11 Via Des Moines Iowa Feb 11th—1902*

*James Black,*

*316 Wabash Ave.,*

*Chicago, Ills.*

*Wire best prices on dressed chix and dux.*

*Eli Harding*

*723 p m.*

NOTE. — Assuming that this message had been received from a line controlled by some other company, the Via is the transfer station, and there being no extra words after the check the receiving office knows they have no office at Tripoli, Iowa. However, if the receiving company also controlled a wire to Tripoli, there would be five extra words, as they count the city, the State, the month, and the date in such cases. In this case one company would be offering business to another at an improper place. At the originating office, the “*via Des Moines*” appears on the same line with the check and is sent until it is delivered to the Des Moines office.

### Query Message.

A message sent to some newspaper, giving synopsis of some event, stating amount of matter contained in the account and inquiring for the amount desired, should always be given quick [pink] service. Example message:

[*hr pink*] 55 F GG. JH.                      16 Collect N. P. R.  
[Night press rate.]  
*Fort Dodge Iowa Feb 3rd—1902*

*To The Bee,*

*Omaha Nebr.*

*Jury finds Miss Adams guilty of murder in  
 the first degree thousand words good story.*

*Clarkson*

*8:12 p. m.*

**Combination Message.***65 DS MK PZ**17 Paid**Des Moines, Iowa Feby 23rd—1902**Deere Mansur Co,**Moline, Ills.**By first freight B 8, one 6 P three 5 M and V 4  
six 2 Q.**Eagle Iron Works.**933 p. m.*

NOTE. — This is a difficult message to transmit and receive, as can be readily seen by the characters in the body or text. It should be handled slowly, accurately, with considerable judgment in spacing, breaking, and resending. Example: “Tt is t fig 8 after t ltr B,” and same with others.

**LESSON IV.****Cablegram.**

Announced “Cable,” because all cables go on special cable blanks, except at “Relay” offices, where they are copied on pink paper.

A cable is a message transmitted, or to be transmitted, by submarine line.



[Cable Received Copy.]

FORM NO. 1818.

**CABLE UNION TELEGRAPH COMPANY.**  
**INCORPORATED**

All Cable Messages received for transmission must be written on the Message Blanks provided by this Company for that purpose under and subject to the conditions printed thereon, and on the back hereof, which conditions have been agreed to by the sender of the following message.

THOS. T. ECKERT, President and General Manager.

**TWO AMERICAN CABLES FROM NEW YORK TO GREAT BRITAIN,  
CONNECTS ALSO WITH FIVE ANGLo-AMERICAN AND ONE DIRECT U. S. ATLANTIC CABLES.  
DIRECT CABLE COMMUNICATION WITH GERMANY AND FRANCE.  
CABLE CONNECTION WITH CUBA, WEST INDIES, MEXICO, AND CENTRAL AND SOUTH AMERICA.  
MESSAGES SENT TO, AND RECEIVED FROM, ALL PARTS OF THE WORLD.**

**Offices in America:**  
All Offices (21,000) of the Western Union Telegraph Company and its Connections.

**Offices in Great Britain:**  
**LONDON:** No. 21, Royal Exchange, E. O.  
No. 109 Fenchurch Street, E. O.  
**LIVERPOOL:** No. 8 Rurnford St.  
**GLASGOW:** No. 29 Gordon St. and No. 4 Waterloo St.  
**BRISTOL:** Backhall Chambers.

RECEIVED AT

Co. KN. MK.

LONDON 4

Duplex Jew,

DES MOINES (Iowa).

Ship.

O. K. KN & MK 836 P. M.

[Sig] Carson.

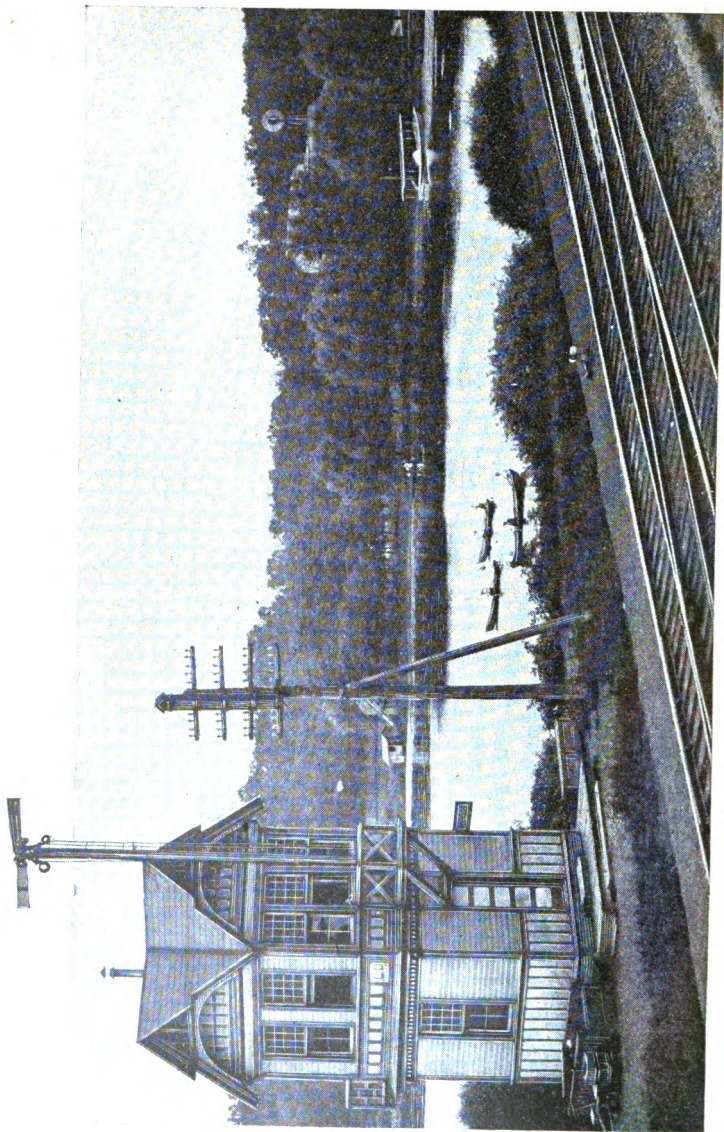

Block signal tower. A charming location for a telegraph office.

All cable messages sent or received should be written on cable blanks, and must always be prepaid, and in place of check only the number of words are mentioned. The maximum length of chargeable words is fixed at ten letters, which applies to the words in the address, destination, and signature. The number of such words appears immediately after the originating point, and no date is given in the cable proper, but a place in each form is left for the operator to fill out. Beginning [to] everything is counted except where the State is in parentheses (Iowa) it is NOT to be counted. If it is not in parentheses it is to be counted.

#### **Message to More than One Address.**

When a message is addressed, for example, to A and B, for delivery to either, it will be transmitted as a single message. When a message is addressed to two parties, endeavoring to get one or the other, as per example, A or B, the word "or" and the second address will be counted in the check as extra words and charged for. When a message is addressed to several persons, for delivery to each of them, the manner of its transmission will be determined by the sending office.

*DS. MK. PZ.*

*11 Paid 3 ex wds.*

*Davenport, Iowa Feb 12th, 1902*

*James G Blair, or John Collins,*

*Laramie, Wyo.*

*Your son found dead on streets last night.*

*M. A. Dowe*

*Mayor.*

*8:30 a. m.*

**Series or Number Service Messages.**

[1] To Sioux City, Iowa.

22nd Sent 28 Rec'd 27 answer.

Cedar Rapids, Iowa Feb 23rd

---

[2] To Cedar Rapids, Iowa

No record of your number 28 Feby 22nd pls describe or give skeleton.

Sioux City Iowa 23rd.

---

**Giving a Skeleton.**

[3] To Sioux City, Iowa.

S. Y. S. ours 22nd number 28 to you Ck 10 pd—  
fm Cedar Rapids Ia to Journal, Sioux City sgd  
Jones. Recd by opr "X" 130 am. ans if OK

Cedar Rapids, Iowa 23

---

[4] To Cedar Rapids, Iowa

Your numbers 22nd O. K.

Sioux City Iowa 23rd

---

**Asking for Quick Answer.**

To Chicago, Ills.

Please get quick answer or reason why ours  
date Savage sgd Jones. Important answer.

Joliet, Ills Feby 23rd, 1902.

---

**LESSON V.****Commercial News Department.**

**Grain, Provision, and Stock Quotations Called  
C N D ' S.**

**Abbreviations.**

W.....	Wheat	P.....	Pork
C.....	Corn	L.....	Lard
O.....	Oats	S. R. [or R]	Short Rib

**Option Months.**

F.....	January	July.....	N
G.....	February	August.....	Q
H.....	March	September.....	U
J.....	April	October.....	V
K.....	May	November.....	X
M.....	June	December.....	Z

NOTE. — The grain and provision market opens up at 9:30 a. m. every morning on the Board of Trade, and quotations are sent out at various hours until 1:15 p.m., which is the close, except on Saturday, when the “Close” occurs at 12:k noon.

**“Opening” Grain C N D.**

[hr Cnd] No 1 CH. NG. MK. [ck] C. N. D.

[Fm] Chicago, Ills. Feb 23rd, 1902

[To] Sioux City, Iowa.

WN 73 1-4 @ 1-2 ; Q 74 1-2 ; Z 71 5-8 [.]

CN 45 3-8 @ 46 ; Q 44 ; Z 46 1-4 [.]

ON 19 1-2 ; Z 20 1-2.

[sig] 9:30 A. M. Opening.

9:35 A. M.

**Form of “Opening” Provision C N D.**

[hr Cnd] No 2 CH. NG. MK. [Ck] C N D.

[Fm] Chicago, Ills Feb 2nd — 1902

[To] Thornburg, Ills.

PN 12.50 ; U 11.50 [.]

LN 7.10 ; U 7.20 [.]

SRN 9.20 ; U 9.50 [.]

[Sig] 9:30 a. m. Opening.

9:36 a. m.

NOTE. — There are also similar quotations for the various fluctuations at 10:00 a. m. and 12:00 o'clock.

**Forms of Live Stock C N D.**

NOTE. — These quotations originate at the Union Stock Yards, and the first or "Opening" C. N. D. is probably more of an estimate than a proper C. N. D. In case the estimate is too large one way or another a second or "Correction" C. N. D. follows the opening which occurs at 7:10 a. m.

Examples :

[Hr Cnd] No 1 CH. NG. MK. [Ck] CND.

Union Stock Yards, Ills Feby 23rd — 1902

[To] Galesburg, Ills.

Hogs 23,000 prospects steady.

Cattle 17,000 prospects unchanged.

Sheep 13,000.

[Sig] 7:10 a. m. Opening.

7:15 a. m.

**Correction C N D.**

[Abbreviated "Corrn."]

[hr Cnd] No 2 CH. AW. MK.

U. S. Yards, Ills Feby 23rd — 1902

[To] Burlington, Iowa.

Corrn — Hogs 25,000. Cattle 17,000. Sheep, 13,000.

[Sig] 7:30 a. m.

"7:35 a. m."

**The "8:40" A. M. C N D.**

[Hr Cnd] No 65 CH. HO. MK. [CK] CND.

[Fm] U. S. Yds, Ills. Feby 23rd — 1902.

[To] Galesburg, Iowa.

A 25,000 B 17176 C 4852 J 3112 K 26,000 averaging shade higher. M 525 @ 562 1-2. N 510 @

552 1-2. P 490 @ 551 1-2. X 490 @ 515. Cattle 17,000 including 2,500 rangers, slow generally 10 lower. Beeves 430 @ 590. Cows and Heifers 300 @ 475. Texas Steers 340 @ 415. Stockers and Feeders 300 @ 470. Western 360 @ 490. Sheep 13000 weak and 10 lower. Native sheep 275 @ 415. Western sheep 340 @ 405. Lambs 375 @ 590. Western Lambs 360 @ 475.

[Sig] 8:40 a. m.

“8:45 a. m.”

**Live Stock “Closing” C N D.**

[Hr Cnd] No 79 CH AN MK. [Ck] C N D.

U. S. Yards, Ills Feby 23rd — 1902

[To] Cedar Rapids, Iowa.

Hogs closing steady M 525 @ 562 1-2. N 510 @ 557 1-2. P 490 @ 552 1-2. Cattle weak : Sheep steady : Lambs 10 lower.

[Sig] 10:10 a. m. Close.

10:15 a. m.

NOTE. — It is not necessary for the student to know the key to the live stock cipher. However, we will give him an inkling of what it refers to, which is sufficient. A, B, C, J, and K refers to exact receipts of the market for the day, export, sales, left over, and total receipts for day before. “M, N, P, and X” means Heavy, Light, Premium, and Mixed hogs. The newspaper telegraphic reports are somewhat different, as can be seen in following example :

FORM NO. 1512.

**COMMERCIAL TELEGRAPH COMPANY.****SPECIAL.**

No.	Sheet	Letter
[hr Spl No]	285 CH. X. Z. Collect D. P. R.	[Day Press Rate.]

[Dated] Chicago, Ills. Feby 23rd, 1902  
 [To] News,

Des Moines, Iowa.

Cattle — Receipts 16,580 ; strong. Beeves 4.60 @ 6.15. Cows 2.75 @ 4.50. Texans 3.35 @ 4.25. Stockers 3.00 @ 4.75. [.]

Hogs — Receipts 31,000 ; average steady. Mixed 5.15 @ 5.60. Heavy 5.20 @ 5.55 1-2. Light 5.25 @ 5.65.

Sheep — Receipts 14,000 ; strong to shade higher. 3.40 @ 4.00. Lambs 4.25 @ 5.85.

[Sig] Richmond.

4:45 p. m.

Filed 4:35 p. m.

---

NOTE. — The punctuations are not sent throughout the "8:40" C. N. D. nor in the specials, but the receiving operator generally knows the form and inserts the decimal points and proper punctuations.



## LESSON VI.

**Government Telegraphic Signals.**

[Hr sigs]

[.] Omaha	lub	carbon	ingret
[.] Orleans	denobe	cascade	carlose
[.] Moines	vinegar	debase	denode
[.] Chian	demite	destone	bedog
[.] Bismarck	keynote	dobey	barvine
[.] Duluth	vanate	dabble	karine

[Sig.] "30"

NOTE. — In this message we have the term [sig] meaning Signals. They have no [ck], no [fm], [to] nor destination. They are made up in Chicago and other large cities and sent out to the different observers in the Government Agricultural Service, known as the Weather Report. Each [.] is a signal to drop a line and begin at the first column, which is an abbreviation for some city. The other code words indicate the temperature and various conditions of the weather, and directions and velocity of the wind.

## Form for Trotting Race in Four Heats.

[Special.]

FORM NO. 1512.

COMMERCIAL TELEGRAPH COMPANY.

### SPECIAL.

No. Sheet Letter

[hr spl No] 234 Z NB. MK. Collect D. P. R.  
Dated Terre Haute, Ind June 28th-1902  
To Tribune, Chicago, Ills.

[.] Today's races failed to develop  
any sensational time, Arlington  
making the best time of 2:06 14 in  
the third heat of the 2:08 pace.

[MM-Paragraph]

In spite of the excellent card  
offered, the attendance was very  
small. The effort for first money  
in the pace was between Arlington  
and The Maid. In the third heat  
[cx] THE MAID went out and dropped  
to third place in the final heat of  
the race.

[MM] Summary [ko]

2:08 Class, Pacing, Purse \$1,000

Arlington	B. H.	(Morgan)	2 1 1 1	[.]
William Mc,	Blk. G.	(Green)	1 3 4 4	[.]
The Maid,	B. M.	(Curtis)	3 2 2 3	[.]
Eyelet,	G. M.	(Thomas)	6 5 3 2	[.]
Flirt,	B. M.	(Jones)	4 4 dis	[.]
Raymond,	B. M.	(Carson)	5 6 dis	[.]

Time 2:08 1-4; 2:08; 2:06 1-4; 2:09 3-4

[Sig] Jennings. 3:45 p. m.

NOTE.—The [mm] meaning to begin a new paragraph; [ko] colon. After sending “Purse \$1,000,” the sending operator would say, “There’s three columns and four heats; begin at 1, 20, and 30 for first three and at 50 on typewriter scale for last four heats. Drop a new line after each period [.]”; thus making it easy work for the receiver. Similar column work is done in the same manner.

### A Special as it is Sent in Code.

Generally Used on all Press Wires at the Present Time.

[hr Spl No] 173 CH NE MK [ck] Coll N. P. R.

[Fm] Cincinnati, Ohio Feb 12th, 1902

[To] Sun,

New York City N. Y.

A dsx fi at 2 oc tsm nry rekd t sto oqd bi Cx Smith Bros on Sta Str. [mm]

T origin f fi is unkn. iw fs dqd bi Cx ofc Obrien dily bak f ofs q lr floor. T flas wr shootg k entrance q alley es t awng hr ws in flas. T fi dpm tru an er, ws cld to thr sto on Madison Str es wn t engs arvd t flas wr mkg gd hedwa d rear prt f bldg es smoke ws isug fm all prts f blg. Fo a ti it lukd as tho t entire block wd b dbf, bt a gen alm ws turned in es t blgs wr flooded w wat. T los to prpty cd nb estmd tsm.

[mm] T stk carried is vld at \$60,000 es t los wi nry rh tt fig. T ins amts to \$40,000 es is distributed amg hom cmps. [mm]

Gx atg t fi ws added to n a lit bi t stament tt  
fifty kegs o powder wr stod q top floor.

[Sig] Richards.

10:10 p. m.

Filed 6:45 p. m.

**The Above Special as Copied by Receiving  
Operator.**

173 CH NE MG Collect N. P. R.

Cincinnati, Ohio, Feby 12th-1902

Sun,

New York City, N. Y.

A disastrous fire at two o'clock  
this morning nearly wrecked the  
store occupied by Smith Bros. on  
State Street.

The origin of the fire is unknown.  
It was first discovered by Officer  
O'Brien directly back of the office  
on the lower floor. The flames were  
shooting out of the entrance on the  
alley and the awning here was in  
flames. The fire department through  
an error was called to their store  
on Madison Street and when the  
engines arrived the flames were  
making good headway in the rear

part of the building, and smoke was issuing from all parts of the building. For a time it looked as though the entire block would be destroyed by fire, but a general alarm was turned in and the buildings were flooded with water. The loss to property could not be estimated this morning.

The stock carried is valued at \$60,000 and the loss will nearly reach that figure. The insurance amounts to \$40,000 and is distributed among home companies.

Great excitement attending the fire was added to not a little by the statement that fifty kegs of powder was stored on the top floor.

[Sig] Richards.

10:33 p. m.

Filed 6:45 p. m.

Every operator should study the Phillips Code. The above is merely used to show its great value not only for newspapers but also every branch of telegraphy. No operator can afford to be without a copy of Phillips Code.

### Form for a "Box Score" Special.

54 DR. N. MR. Coll. N. P. R.

Cleveland, Ohio, May 23rd, 1902.

Free Press,

Detroit, Mich.

After losing eleven straight games Cleveland defeated Detroit today by a score of 9 to 7. A combination of errors, a passed ball, a base on balls, and four hits gave Cleveland four runs and the game in the fourth inning. Attendance, 3,255.

Cleveland	R.	H.	P.	A.	E.	Detroit	R.	H.	P.	A.	E.
Pickering, rf.	2	4	2	0	0	Casey, 3b.....	1	2	1	5	0
McCarthy, lf.	1	1	0	0	0	Ogren, cf.....	1	2	0	0	0
Bradley, 3b....	0	0	2	1	0	Gleason, 2b... 0	1	2	5	0	0
Lachance, 1b.	1	3	13	0	1	Holmes, lf....	1	2	1	0	0
Beck, 2b.....	1	2	2	3	1	Dillon, 1b.....	0	0	15	0	1
Shay, ss.....	0	0	4	4	0	Elberfield, ss.	1	2	1	2	1
Wood, c.....	2	2	2	4	0	Nance, rf.....	1	1	2	1	0
Genine, cf.....	0	1	2	0	0	Miller, p.....	1	1	0	0	0
Scott, p.....	2	1	0	3	0	McAllister, c.	0	0	2	0	0
						* Frisk.....	1	1	0	0	0

Totals 9 14 27 15 3

7 12 24 21 3

\* Batted for Miller.

Cleveland.....	1	0	0	5	0	1	2	0	—	9	
Detroit.....	1	0	0	1	2	2	0	0	1	—	7

Earned runs—Cleveland 5; Detroit 1. Two base hits — Lachance, Scott, Pickering, Elberfield. Bradley. Three base hits — Elberfield. Sacrifice hits — McCarthy, Shay, Genine, Dillon. First

*base on balls — off Scott, 1; Miller, 2. Struck out — by Scott, Miller. Wild pitches, Miller. Passed balls — McAllister. Time — 1:35. Umpire — Jack Sheridan.*

[*Sig*] Jones.

*Filed 7 p. m.*

NOTE. — The column work in this special would be handled the same as in the race special, except that in place of sending the cipher, the letter O or two dots would be substituted in running across the page, and a period would be made the same in this as in other work, when a new line was begun.

## LESSON VII.

### Receiving Department.

#### The Tariff Book.

To ascertain rates between stations a tariff book is used for the guidance of employes of the various companies. It contains a complete list of the telegraph offices of each company and its connections, together with the names of the places which may be reached by telephone or special delivery from the nearest telegraph office.

“Other Line” telegraph offices, *i. e.*, offices on lines owned or operated by other than the one on which an operator is employed are designated by single stars, thus :

\* Abbeville.

Stations, places, establishments or institutions to which messages are delivered from the nearest telegraph offices are designated by *two* stars, thus :

\* \* Avondale.

Places to which messages are delivered by telephone from the nearest telegraph office, are designated by three stars, thus:

\* \* \* Argo.

When the telegraph and P. O. [post office] names of a place are not the same, the post office name will be found immediately *after* the telegraph name, as:

Barclays, P. O. Miles.

Mail matter intended for the telegraph office at Barclays should be addressed to Miles, which is the post office address of Barclays.

### **Rates.**

In addition to a tariff book, each office should have a tariff sheet showing Square and State rates. The tariff sheet should be placed where it will be preserved, and where it can be easily referred to.

The different rates are known as:

Special Rates,

Square Rates,

State Rates.

Special rates are given by special instructions, and are to be used in accordance therewith.

Square rates come under the heading "SQ" [Square] and denote the squares in which offices are located.

State rates are given on the tariff sheet for all States from a given State.

Rates given in the tariff book and on the tariff sheet are for messages of ten words or less, exclusive



of date, address, and signature. Additional word rates are given with the ten-word rate.

To ascertain the rate to an office to which no special rate has been given, note first the number, if any, of the Square before the name of the office, and then refer to the sheet showing Square and State rates ; if there be a rate to the number noted, which is *lower* than the State rate to the State, Territory or Province in which the office is situated, then *that rate* will be the rate desired ; but if there be no rate to that number, or if the rate given be *higher* than the State rate, then the State rate will be the rate desired. Where a notation of instruction to *check* with some other office follows the name of an office, it should not be understood that such notation makes the rate the same as to the checking office. When that is intended the notation will be found to read, "Tariff same as and check," or "Tariff same as," etc.

With the name of each "Other" line or single star [\*] office, will be found the *other* line rate from at least one "*Check direct*," connecting office. To ascertain the rate to an "Other" line office, add the "other" line rate *from* the connecting office to your own line rate *to* the connecting office. Example :

\* Brilliant 25-2 [25-1 N. M.] Birmingham.

The day rate to Brilliant is the "other" line rate [twenty-five cents for ten words or less, and two cents for each word over ten] *from* Birmingham, added to the rate from your own office *to* Birmingham.

[NOTE.—The name of Birmingham's State is not given, for the reason that it is the same as that of Brilliant. Where the State in which any one or more of the connecting offices is situated is not the same as that of the office to which rate is given, it will be found printed with the name.]

Where two or more "other" line rates are given, two or more routes, for messages to the other line office, are thereby indicated. In such cases, the route by which a message may be *most promptly* forwarded to its destination should be chosen, and the rate computed *via* that route.

To telephone and double star [ \* \* ] stations, the rates will be found in the same way as are rates to "other" line offices. When a message is to be mailed to a station the sender should *not* be charged for postage.

### **Words to be Counted and Charged For.**

In a prepaid message the under-mentioned words will be counted and charged for, viz. :

All words in an extra date.

All extra words in an address.

[NOTE.—In the address of a message to one person, or to a firm, or to "*Mr. and Mrs. ———*" there are no extra words; but in the address of a message to *either* of two or more persons in the same place or town, as to "*John Smith, or James Brown, 80 Wall Street, New York,*" there are three extra words, viz. : "*Or James Brown,*" which will be included in the count and charged for.]

All words, figures, and letters in the body of a message.

All signatures, when there are more than one, except the last.

All words in excess of two, in a title after the last or the only signature.

[NOTE.—In a signature such as “*Mr. and Mrs. ———*,” or “*John Smith and family*,” or “*Henry Jackson, Vice-President*,” there are no extra words, but such as “*James Brown, First Vice-President and Secretary*,” there are two extra words, viz. : “*And Secretary*” which will be included in the count and charged for.]

All words after the signature which are not title words; and, in the check, the words, “*Deliver and report charges*,” “*Delivery Charges Guaranteed*,” “*Report Delivery*,” and “*Repeat Back*.”

In a collect message will apply, except that the word “*Collect*” in the check will be counted but not charged for.

When a message bears two or more addresses, *and delivery is to be made to each address*, it will be charged for as two or more messages, as the case may be. Example :

A message addressed to

“*W. Brown, 197 Broadway, and*

*B. Wells, 60 Exchange Place, N. Y.,*”

will be charged for as two messages. The additional address will not be considered as extra words.

In counting a message, dictionary words, initial letters, surnames of persons, names of cities, towns, States or territories, or names of the Canadian prov-

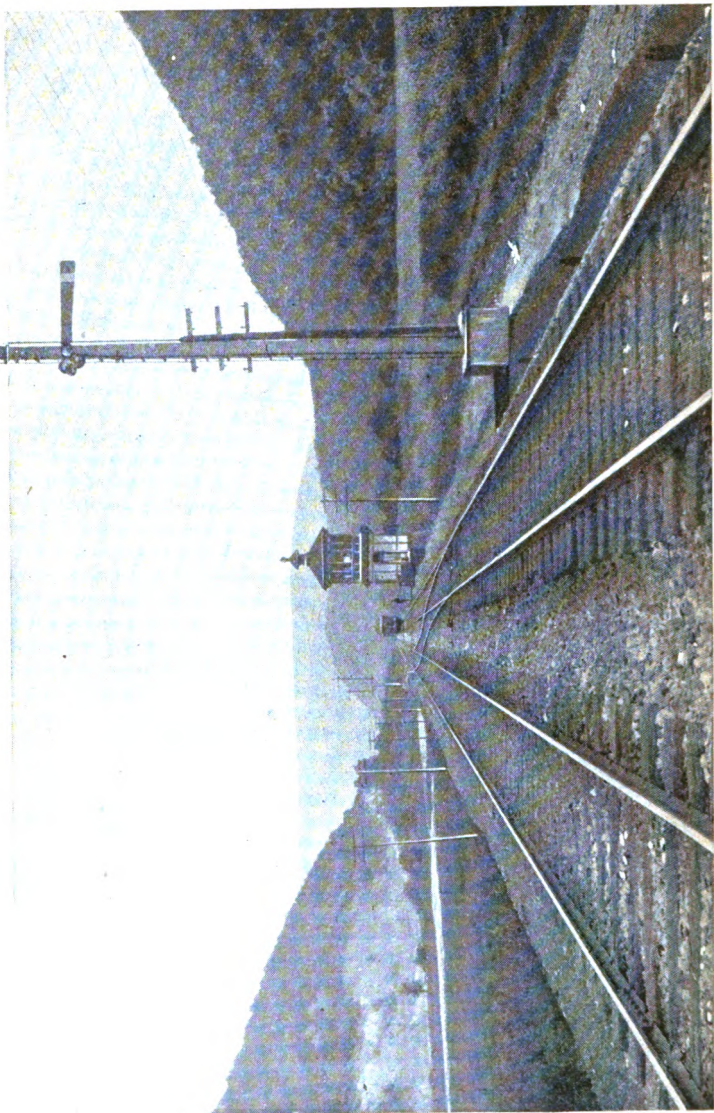

Block signals on the Pennsylvania R. R. Operator permitting "The Flyer" to pass.

inces, will be counted and charged for each as one word. The abbreviations for the names of cities, towns, villages, States, territories, and provinces will be counted and charged for the same as if written in full. Abbreviations of weights and measures in common use will be counted, each as a word.

In names of countries or counties all the words will be counted and charged for.

To prevent liability to error, numbers and amounts should be written in words, and when not so written, the receiving clerk can request that it be done. If the customer refuses to write the amount in words, the message will be accepted as written, and the figures counted as indicated in the following paragraph :

Figures, decimal points and bars of division, and letters will be counted — each separately — as one word.

In ordinal numbers the affixes St., D., nd, rd, and th, will each be counted as one word.

All pronounceable groups of letters, when such groups are not combinations of dictionary words, will be counted each group as one word. When such groups are made up of improper combinations of dictionary words, each dictionary word so used will be counted as one word.

REMARKS.—The following examples will illustrate the application to the above rules :

Van Dorne . . . . .	1 Word.
McGregor . . . . .	1 “
O’Conner . . . . .	1 “
DeWitt . . . . .	1 “

Brown Jr . . . . .	2	Word.
New York [or N. Y.] . . . . .	1	"
New York State . . . . .	2	"
Nova Scotia [or N. S.] . . . . .	1	"
St. Louis . . . . .	1	"
East St. Louis . . . . .	1	"
North Carolina . . . . .	1	"
Queen Anne County . . . . .	3	"
New Mexico . . . . .	1	"
District of Columbia [or D.C.]	1	"
North America . . . . .	2	"
44.42. . . . .	5	"
42B618 . . . . .	6	"
74 3-4 . . . . .	5	"
No. 185 22d St . . . . .	8	"
10 000 000 . . . . .	8	"
Ten Millions . . . . .	2	"
3d [or 3rd] . . . . .	2	"
10th . . . . .	3	"
Lbs . . . . .	1	"
Cwt . . . . .	1	"
Amaurecis . . . . .	1	"
Adbantia . . . . .	1	"
Chancin . . . . .	1	"
Interavis . . . . .	1	"
Byxtrm90 . . . . .	8	"
Xyf194sm . . . . .	8	"
All-right [or alright] . . . . .	2	"

## EXCEPTIONS..

A. M. . . . .	1	Word.
P. M. . . . .	1	"
F. O. B. [or fob] . . . . .	1	"

C. O. D. [or cod] . . . . .	1	Word.
C.I.F. or C.F.I. [or cif or cfi]	1	“
O. K. . . . .	1	“
C. A. F. [or caf.] . . . . .	1	“
Per cent . . . . .	1	“

## LESSON VIII.

### Delivery Department.

#### Messages to be Copied.

Each message to be delivered will be copied and enclosed in the proper envelope, which will be carefully sealed and fully and plainly addressed.

#### Amount of Tolls to be Written on Envelopes.

When tolls are to be collected, the amount in words will be written in ink upon the envelope, and also upon the messenger's delivery sheet.

#### Sending Office's Instructions as to Delivery.

Instructions from the sending office in regard to the delivery of a message will be carefully observed. A request to "*report delivery*" will be answered by a collect message addressed to the sender of the original message, stating the time of the delivery, or, if not delivered, the reason why it was not delivered.

#### Messages Addressed to More than One Person.

When a message addressed, for example, to "A or B" is received, it will be delivered to either one or the other of the addresses.

**Messages Requiring Answers.**

When a message requires an answer, the word "answer" will be plainly written on the envelope, and the messenger will be instructed to make diligent efforts to obtain such answer. Should he fail to obtain it, he will report the reason to the delivery clerk. Messengers will, in all cases, be supplied with proper blanks on which answers can be written.

**Free Delivery Limits.**

Messages will be delivered free within a radius of one-half mile from the office in any town or city of less than 5,000 inhabitants, and within a radius of one mile from the office in any city or town of 5,000 or more inhabitants. Beyond these limits only the actual cost of the delivery service will be collected. The manager will, however, see that such cost is as reasonable as possible.

**Special Delivery.**

If the service of a special messenger be required, and the special delivery charges have not been provided for, the sending office will promptly be notified by telegraph of the cost of delivery, and that office will endeavor to collect the charges for delivery of the sender, who, if he pays or guarantees the delivery charges, will also pay for the message ordering the special delivery, or guarantee the collection of the tolls thereon. If the sending office be unable to collect, or if a reply from the sending office to the notice be not promptly received, a copy of the message will be mailed to the addressee, and



if another copy be afterward delivered, the word "Duplicate" will be plainly written across its face.

### **In Case of Failure to Collect Delivery Charges.**

When special delivery charges which have been guaranteed can not be collected by the office making the delivery, the sending office will be immediately notified by a service message of the failure to collect and of the amount of charges.

### **Messages not to be Delivered to Unauthorized Persons.**

A message must not be left with a janitor or porter of a building for delivery by him, nor be slipped under a door, nor left in a letter box, unless the addressee has filed with the manager a written request for such delivery; nor will a messenger allow an unauthorized person to know to whom a message is addressed.

### **Notice to Addressees of Undelivered Messages.**

When a message can not be delivered because the addressee's place of business or residence is closed, or because no authorized person can be found to receive the message, the messenger will leave a notice at the place of address to the effect that a message for the addressee is at the office of the company awaiting delivery. The undelivered message will then be returned to the office, with the reason of the non-delivery indorsed upon the envelope, and will be delivered as early thereafter as possible.

Form No. 66.

W. U. TELEGRAPH CO., ..... 190

**WESTERN UNION TELEGRAPH COMPANY.**

— INCORPORATED —

..... 190

Mr. ....

*There is a telegram for you (No. ....), at office  
your address to give a receipt at.....o'clock and.....  
minutes.*

*Another effort will be made to deliver the telegram  
referred to. If you call in meantime, please bring this  
notice with you. Very respectfully,*

*Messenger No. ....*

.....  
*Message No.*.....

*Address*.....

*Notice left at No.*.....

*Street*.....

*at ..o'clock and..min.,..M*

MESENGER No. ....

**Non-Delivery in Consequence of Wrong Address.**

When a message can not be delivered on account of a wrong or an inadequate address, or because the addressee is unknown, a record of the facts will be made upon the envelope of the undelivered message, and the sending office will be promptly notified by telegraph of the non-delivery. The service message giving such notice will contain the address of the message as received, and the reason of the failure of delivery. On receipt of the telegraph notice, above referred to, the sending office will compare addresses, and will correct by telegraph any error that may be found. If no error appears, notice will be given to the sender of the message, who, if he desires to change the address, must either send a new message, or pay for the service message necessary to change the address of the original.

Pending the correspondence as to better address, the receiving office will put a copy of the message, addressed as first received, in the post office.

**Messages Delivered "Subject to Correction."**

If a manager believes that a mistake has been made in the transmission of a message to his office, and the correction can not be quickly made, he will deliver the message with the words, "*Delivered subject to correction,*" indorsed thereon. He will then take steps to secure a correct copy, which will be indorsed, "*Corrected Copy,*" and will be promptly delivered. If no error be found a notice to that effect will be delivered.

**Message Offered During the Interruption of Lines.**

If a message be offered when communication is known to be interrupted, it will be accepted only if the sender chooses to leave it for transmission when communication is restored. Upon such a message write the words, "Subject to delay," and request the sender to affix thereto his signature or initials.

**No Promises as to Transportation or Delivery.**

Employes are particularly cautioned against making any promise to customers respecting the transmission or delivery of a message.

**Sender's Address to be Taken.**

The address of the sender of a message, unless it be well known, will be requested and recorded.

**Messages to be Prepaid.**

All messages will be prepaid, except free messages and those covered by rules following.

**Collect Messages.**

An answer to a prepaid message, or a message for which payment for transmission, or for special delivery, is guaranteed by a responsible party, may be accepted "*Collect.*"

**Guaranteed Deposits.**

When a deposit has been made to guarantee payment for transmission, or for special delivery, the deposit will be returned after three days, if no

notice of failure to collect the charges has been received. But if a notice of failure to collect be received, the amount due the company will be deducted from the deposit, and the remainder will be returned.

### **Profane or Obscene Messages.**

A message containing profane or obscene language will not be accepted for transmission over the wires of any company.

### **Railroad Messages.**

A message of an officer or agent of a railroad company with which a telegraph company has a contract, when on the business of such railroad company, may be sent free, without a "frank," between stations on such road; but when such message is offered at or for a place beyond or off such road, it will not be sent free unless covered by a "frank."

### **Delivery of Messages Without Payment.**

If the addressee of a collect message refuses to pay for the same the message will nevertheless be tendered to him, and unless the message be an answer to a free or to a paid message, notice of the failure to collect will be at once given to the sending office by service message.

### **Delivery of Night Messages and Delivery of Night Messages When Called For.**

A night message will not, unless called for, be delivered until the morning of the next business

day after its date ; except upon payment of full day rates in case of a collect message, and the difference between the night and day rates in the case of a paid message. The additional amount collected will be accounted for as "Sundry Receipts."

#### **Delivery of Insured Messages.**

When an insured message is received at an office from which it is to be delivered, it will be the duty of the manager, or of the person in charge, to satisfy himself that prompt and correct delivery is made.

#### **Messengers' Books to be Examined.**

The manager or the delivery clerk will examine the delivery sheet or books of each messenger on his return from each service, and at the close of the day, to see that faithful delivery has been made, and that all proper notifications have been given.

## **LESSON IX.**

### **Accounts, Reports, and Remittances.**

#### **Classification of Offices.**

For the purpose of accounts and reports, offices are classified as follows :

"First Class," those whose messages number over one thousand per month.

"Second Class," those whose messages number over two hundred but not over two thousand per month.

"Third Class," those whose messages number less than two hundred per month.

**Classification not to be Changed.**

An office of one class will not change the method of keeping its accounts to the method of another class, without the consent of the superintendent.

**Record of Messages.**

A daily record of its messages will be kept by each office. For this purpose offices will use the form designated for their respective class.

**All Messages to be Entered in Check Ledger.**

Offices of each class will, each day, enter on the ledger the paid and collect messages of the preceding day—including the “half-rate frank” messages, which must be entered as paid full rate. The messages will be entered so that the names of the office with which the business was done will appear in exactly the same order in which they are in the tariff book: *i. e.*, so that the names of the States [or the abbreviations thereof], and also the names of the offices *in each* State, will appear in alphabetical order. The amount entered in the last column [“This office checks for other lines”] will be made up of the amount paid to “Other lines,” the amount paid out for special delivery service, and that part of the tolls on forwarded messages designated as “other line” tolls in its check.

**Record of Free Messages.**

A separate record of free messages, not including service messages and local railroad messages [*i. e.*,

messages between two stations located on the same line], will be made by offices of each class in check ledger. This record will state the number of messages sent TO, and the number received FROM, each office, together with the total amount of "this" line tariff on the messages at full day rate, the tariff on sent messages being entered as credits, the tariff on received messages being entered as checks. No account of "Other" line tariff will be taken in this record of free messages.

In case of a message free for "this" line and paid for "other" lines, an entry in both the free and paid message records will be made. A copy of the message will be made for the paid message files, and the original will be placed with free messages.

#### **Sunday's Messages.**

Sunday's messages are entered as a part of the previous Saturday's business, except when the first day of the month falls on Sunday, in which case Sunday's messages are entered as a part of the business of the following Monday.

#### **Checks not to be Changed.**

A paid or collect message will be entered as originally checked and transmitted.

#### **Uncollect, Guaranteed, "Half-Rate" and Free Messages.**

Before filing away the day's business the under-mentioned messages will be taken out and held to be sent in with the monthly reports:

Copies of messages "received collect" for which



payment has not been obtained, together with the telegraphic notices relating thereto.

The original messages "sent collect" which have been reported by delivery offices as uncollectible.

The original messages "sent paid" *by*, and copies of those "received collect" *for*, the holders of "half-rate franks," on which less than full tolls have been paid.

The original of all *sent* messages [except service and local railroad messages, *i. e.*, messages between two stations, both located on the same road] which have been transmitted free.

#### **Filing Messages.**

All messages not required for other purposes will be filed in the order in which they appear on Check Ledger and properly labeled by days and months. Each month's messages will be retained for a period of six months, at the end of which time, unless otherwise ordered, they will be sent to the superintendent with monthly reports.

#### **Monthly Report.**

Immediately after the close of the month, offices not otherwise instructed by the superintendent will make out and return reports on Account Current Sheet, Check Report Sheet, Free Message Report, and Cable Message Report.

If no free business has been done, the report on Free Message Sheet will be omitted, and the words "No free business" will be indorsed on it under the manager's signature. If no cable business has been done, the same refers to that sheet.

The above named reports with their inclosures will be sent to the superintendent by the offices of the third class within three days after the close of the month, by the offices of the second class within five days, and by offices of the first class within seven days.

#### **Paid Other Lines.**

The amounts entered in the column headed "Paid Other Lines" on Account Current will be made up of the amount paid to "other" lines, the amount paid for "Special Delivery," and the "other" line tolls on forwarded messages. The total of the amount in this column will be entered under "Schedule of Ordinary Disbursements" opposite the item, "Paid Other Lines."

#### **Received for Guaranteed Messages.**

Under "Sundry Receipts" on "Account Current Sheet," opposite the item received for "Guaranteed Messages," will be entered the amount received for the payment of messages which other offices have reported "uncollectible." The original of such messages will be sent in with the reports; and upon those for which no tolls have been collected will be indorsed the reason why no collection has been made.

#### **Refund and Uncollectible.**

The amount opposite the item, "Refund and Uncollectible," on Account Current Sheet, will be made up of the amount refunded for errors, etc.,

the total amount of refunds on "half-rate franks" messages, and the amount of tolls on uncollectible messages received from other offices.

### **Check Reports.**

A check report is required from every office.

The names of Commercial telegraph offices to which messages have been sent, or from which messages have been received during the month, will be entered on this report in the order indicated by the note in the heading of the form, and opposite the names will be entered the amounts as indicated by the headings on the form. The totals of the columns under the heading, "This Office Receives," must agree with the totals of the "Account Current" under the heading, "Telegraph Receipts," and the total of the column headed, "For Other Lines," under "This Office Checks," must agree with the total of the "Paid Other Lines" column and with the item, "Paid Other Lines," under the heading, "Schedule of Ordinary Disbursements."

### **Free Message Report.**

The free message report will be made a check report of free messages and a statement of messages which have been sent free for any railroad, transportation, express or other company or for any individual, showing the number of messages sent for each company or individual, and the amount of tariff at full day rates therefor as if paid for. The original messages will show the place of origin, be checked with the number of words, the *amount*

*of tariff at full day rates* [which rates should be plainly marked in the upper left-hand corner] and the reason *why free*, and will be sent with the report to the superintendent.

### **Vouchers.**

A voucher will be rendered for every expenditure.

Each voucher will be written and signed in ink, made out in such manner as to clearly and fully explain itself, and numbered so as to correspond with the entry on the "Account Current."

The amount of the expenditure will be written on the receipt in words.

No voucher bearing erasures or alterations of figures or amounts will be accepted.

Each voucher will be signed by the person to whom payment is made.

If a voucher be signed by any other than the person to whom payment is due, it will be accompanied by a written order from such person giving authority for the payment and signature.

Signature by "His Mark," will be witnessed by some person other than the one making payment.

### **Service Vouchers.**

A service voucher will state the full name of the person paid, the kind of service, and where rendered, the dates between which the service was performed, and the rate per day, week, or month. When the payment is for a part of a month, the number of days as well as the dates will be given, and the time will be compiled according to the number of week-days in the month.

### **Error Sheet.**

Each manager will give prompt attention to error sheets, and will answer inquiries respecting them with full and clear explanations.

### **Balance Due Company.**

Every office balance due the company will be remitted to the treasurer at the close of each month, unless otherwise specially ordered by him.

### **Remittances.**

A remittance will be made to the treasurer either through the mail in the form of a draft, or when bank drafts can not be obtained at less expense, by the express company's money order.

If neither bank draft nor money order can be obtained, post office money orders should be forwarded.

If neither draft, express money order nor post office money order can be obtained, then currency should be sent by express.

If neither of the above means is available, then, as a last resort, the remittance shall be forwarded by registered letter.

### **Privacy of Messages and Records.**

Messages, books, press reports, and other papers of the company will be guarded with the greatest care and held in strictest privacy. Employes are expressly forbidden to disclose any information in regard to the contents of a message, or the name of the sender or addressee thereof.

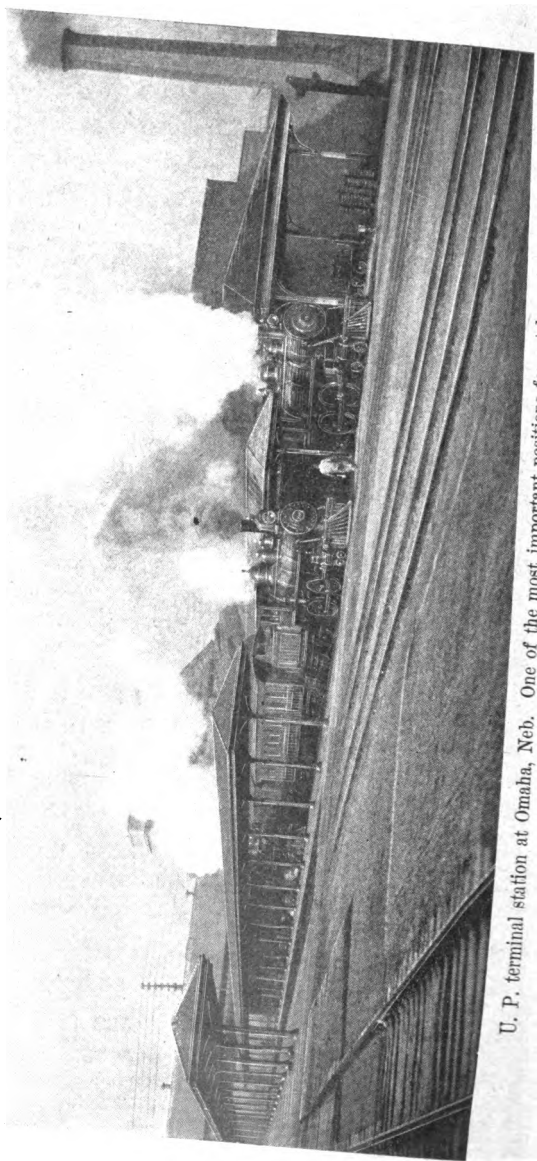

U. P. terminal station at Omaha, Neb. One of the most important positions for a telegraph operator.

**Forms to be Used Only for Designated Purposes.**

The printed forms of a company will be used only for the purpose for which they are designed. Under no circumstances will the forms for received messages or message envelopes be given to the public, except in the usual delivery of messages.

**Applications for Copies of Messages.**

When the sender or the addressee of a message applies for a copy of such message, he may, if known or properly identified, be allowed to see the message and make a copy thereof; but under no circumstances will a received message form or a message envelope be furnished him.

Employes will not certify to the correctness of any message or copy thereof nor furnish a copy, except as per following rule, nor will they show any message to any person other than the sender or addressee thereof, except by authority of an executive officer of the company.

**Correction of Errors.**

If, after the delivery of a message, the addressee claims that a mistake has been made by the company, and the error be not apparent to the manager, the manager may, by service message to the sending office, [*which message must be paid for,*] ask for a duplicate, and if an error be thereby disclosed, a copy endorsed, "*Corrected Copy,*" will be delivered, and the tolls paid for the service message be refunded. If no error be disclosed, a notice to that effect will be delivered.

### Refunds.

Whenever satisfactory evidence is furnished to the manager that a message has failed to accomplish its object by reason of imperfect service on the part of the company, he may refund to the sender the tolls paid for the message. The receipt given for the refund tolls, together with the message and an explanatory memorandum, will be sent in with the report on "Account Current."

### Transmission of Repeated Messages.

NOTE. — Special care must be observed in sending a message requiring *repetition*, which should, of course, be from point of origin to destination.

At the office of origin, and at each repeating office, the operator will, upon receiving a repeated message, *immediately* repeat it back to the operator sending it to him, before anything further is done with it, and if the repetition be found to be correct, he will write on the message "Rpd" O. K. with his sign.

### Transmission of Insured Messages.

An insured message will be preceded in the transmission by the word "Insured," and will be repeated back from office to office. Each operator receiving such a message to be forwarded over another circuit will PERSONALLY deliver it to the other operator about to send it.

### When Messages can not be Promptly Transmitted.

When for any reason an operator can not raise another office, or when (wires are impracticable)



during stormy weather, an operator must note the cause of delay upon the back of the message. When delayed owing to inability to raise another office, mark the time on the back of the message as you call him every few minutes.

#### **Contention for Circuit.**

Contention for circuit is positively prohibited, and, as a general rule, operators that fall into this habit last but a short time with any company.

#### **Ground Wire**

At intermediate offices, will be used in event of an interruption of the circuit, first to notify chief or testing operator, and second, to move old business. Always try both sides when testing with ground wire, and if you do not get a circuit either way, look around your own office for trouble, as it is a case generally of a broken wire or a loose screw somewhere.

#### **Cut out your Instruments at Night.**

Before closing an office temporarily, or for the night, cut your instruments out, and see that the circuit through the board is complete.

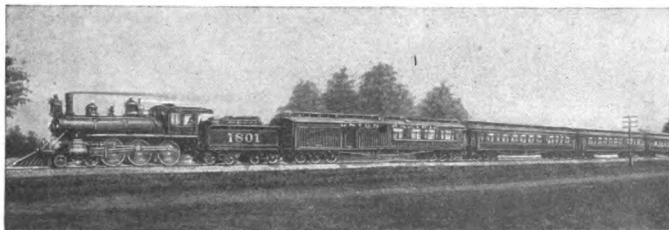

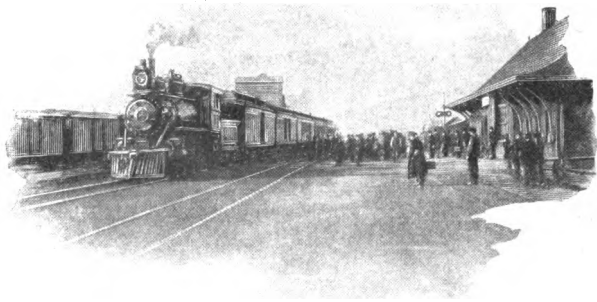

## INDEX.

---

	PAGE
Abbreviations .....	202
Abbreviations, common railroad .....	107
Abbreviations, railroad, used on wire .....	104
Accounts, reports, and remittances .....	228
Alphabet .....	34
Asking about delivery, form .....	188
Asking duplicate for a certain word .....	189
Asking for quick answer .....	202
Balance due company .....	235
Beginners, instruction for .....	11
Block examination .....	150
Block signaling .....	139
Block signals, telegraph .....	138
Blockwire work .....	146
“ Box score ” special .....	212
Breaking .....	65
Cablegram .....	198
Cable message .....	199
Car reports .....	173
Cars .....	90
Caution card .....	143
Check .....	57
Check reports .....	233
Checks not to be changed .....	230
Cipher and code message .....	188
Circuits .....	22
Classification not to be changed .....	229
Classification of offices .....	228
C N D abbreviations .....	202
C N D correction .....	204
C N D, forms of live stock .....	204
C N D, live stock “ closing ” .....	205

	PAGE
C N D "opening" grain.....	203
C N D option months.....	203
C N D'S, quotations called.....	202
C N D, the "8:40" A. M.....	204
Code and cipher message.....	188
Collect messages.....	226
Combination message.....	198
Commercial abbreviations.....	66
Commercial business.....	55
Commercial news department.....	202
Commercial work, advanced.....	179
Conductors and insulation.....	16
Contention for circuit.....	239
Copy, how to.....	66
Correction C N D.....	204
Correction of errors.....	237
Correcting the word.....	190
Cross-over permit.....	145
Danger signals.....	112
Dash letters.....	39
Day operator to be called.....	76
Deadhead message.....	183
Definitions.....	87
Delayed series message.....	186
Delivery charges, failure to collect.....	223
Delivery charges guaranteed.....	182
Delivery charges, when not guaranteed.....	182
Delivery department.....	221
Delivery, instructions as to.....	221
Delivery, no promise as to.....	226
Delivery, other forms asking about.....	188
Deposits guaranteed.....	226
"Detail" or destination report.....	173
"Detail" train report.....	170
Dollar mark.....	40
Dot letters.....	39
Dots and dash combination.....	39
Duplicate for a certain word, asking.....	189
Duplicate transmission.....	189
Electricity.....	12

	PAGE
Electro-magnetism .....	17
Engine signals .....	116
Engine signals and markers .....	119
Errors, correction of .....	237
Error sheet .....	235
Extra trains .....	136
Extra trains, schedule for .....	135
Faults .....	24
Figures .....	41
Flags and lamps .....	111
Form for a "box score" special .....	212
Form for trotting race .....	208
Form of "opening" provision C N D .....	203
Forms for designated purposes .....	237
Forms for live stock C N D .....	204
Forwarding messages .....	192
Fractions .....	40
Free delivery limits .....	222
Free messages, record of .....	229
Free message report .....	233
Fusees .....	112
Government message .....	182
Government telegraph signals .....	207
Grain C N D, "opening" .....	203
Grain message .....	184
Ground wire .....	239
Guaranteed delivery charges .....	182
Guarantee on a message, asking for .....	182
Hand, flag, and lamp signals .....	114
Holding order .....	137
Information, general .....	75
Instructions, general .....	73
Instruments, cut out at night .....	239
Instruments employed .....	19
Insured messages, delivery of .....	228
Insured messages, transmission of .....	238
Interruptions .....	24
Lamp signals .....	115
Lights, tail .....	113
Live stock "closing" C N D .....	205

	PAGE
Loop peg and cord .....	28
Make up .....	65
Make up report .....	99
Manipulation .....	37
Markers .....	113-117
Markers and engine signals .....	119
Message, asking for a guarantee on a .....	182
Cable .....	199
Code and cipher .....	188
Combination .....	198
Correcting address .....	185
Deadhead .....	183
Delayed series .....	186
Government .....	182
Grain .....	184
Night .....	191
Query .....	197
"Relay" .....	185
Report, free .....	233
Request to report delivery .....	186
Requiring special delivery .....	179
"Through" .....	185
Uncollect .....	186
Where no such number .....	184
Wrong address .....	184
Yard .....	98
Messages addressed to more than one person .....	221
Application for copies of .....	237
Collect .....	226
Delivered "subject to correction" .....	225
Delivery of insured .....	228
Delivery of night .....	227
Delivery of, without payment .....	227
Filing .....	231
Forwarding .....	192
Free .....	230
Guaranteed .....	230
Half rate .....	230
Insured .....	238
Night or red .....	190

	PAGE
Messages — continued.	
Not to be delivered .....	223
Offered during interruption .....	226
Privacy of .....	235
Profane or obscene .....	227
Railroad .....	227
Received for guaranteed .....	232
Record of .....	229
Record of free .....	229
Repeated .....	238
Requiring answers .....	222
Sent to agents .....	110
Series or number service .....	202
Service and office .....	69
Sunday .....	230
Technical .....	169
To be copied .....	59-221
To be entered in check ledger .....	229
To be prepaid .....	226
To more than one address .....	201
Uncollect .....	230
When can not be promptly transmitted .....	238
Messengers' books to be examined .....	228
Monthly report .....	231
Morse alphabet .....	33
Morse system of telegraphy .....	33
Movement .....	38
Night messages, delivery of .....	227
Night or red messages .....	190
Non-delivery in consequence of wrong address .....	225
Numbering .....	75
Numbers .....	41
Number schedules .....	75
Obscene or profane messages .....	227
Offices, classification of .....	228
“Opening” grain C N D .....	203
“Opening” provision C N D, form of .....	203
Option months .....	203
Order, annulling an .....	137
Order form, telegraphic .....	176

	PAGE
Order, holding .....	137
Order "31" "X" .....	167
Orders, sending on the wire .....	79
Orders, technical .....	163
"OS"-ing .....	75
Paid other lines .....	232
Penmanship .....	53
Pick up message .....	130
Plug cut-outs .....	26
Position .....	37
Practical hints .....	177
Prepaid messages .....	226
Profane or obscene messages .....	227
Privacy of messages and records .....	235
Provision C N D, form of "opening" .....	203
Punctuation .....	46
Punctuation, compound .....	49
Punctuation, explanation of simple .....	47
Query message .....	197
Railroad abbreviations, common .....	107
Railroad abbreviations used on the wire .....	104
Railroad messages .....	227
Railroad messages, practical .....	95
Railroad telegrams .....	95
Railway telegraphers, practical hints for .....	177
Railway telegraphy, beginning .....	73
Rates .....	214
Received copies, two different .....	64
Received message, answer to .....	63
Receiver's number .....	57
Receiving .....	50
Receiving department .....	213
Record of free messages .....	229
Record of messages .....	229
Records, privacy of .....	235
Red or night messages .....	190
Refund and uncollectible .....	232
Refunds .....	238
"Relay," meaning of .....	185
Relay, the .....	20



	PAGE
Release .....	144
Remittances .....	235
Repeated messages, transmission of .....	238
Repeating .....	80
Report, car .....	173
Report, delivery message .....	186
Report, "detail" or destination train .....	173
Report, monthly .....	231
Reports, check .....	233
Resonators .....	21
"Rights," special order .....	88
Rules for movement of trains .....	76
Scheduled train, annulling .....	137
Schedule for extra train .....	135
Schedules, number .....	75
Sender's address to be taken .....	226
Sending .....	42
Series or number service messages .....	202
Service and office messages .....	69
Service vouchers .....	234
Signaling, block .....	139
Signalmen .....	141
Signals .....	111
Carried on engines and trains .....	112
Danger .....	112
Engine .....	116
Flag .....	114
Government telegraph .....	207
Hand and lamp .....	115
Hand, flag, and lamp .....	114
Numeral .....	82
Station .....	111
Whistle .....	112
White .....	113
Skeleton, giving a .....	202
Sounder, the .....	20
"Soup ticket" .....	171
Special .....	206
Special as copied by receiving operator .....	210
Special as sent in code .....	209

	PAGE
Special delivery.....	222
Special delivery, message requiring.....	179
Special, form for a "box score".....	212
Special order "rights".....	88
Station signals.....	111
Student's outfit.....	13
Sunday messages.....	230
Switch-board.....	27
Tariff book.....	213
Technical messages.....	169
Technical orders.....	163
Technical terms.....	89
Telegrams, railroad.....	95
Telegraph block signals.....	138
Telegraphers' script.....	54
Telegraphic order form.....	176
Telegraphic orders, beginning.....	81
Telegraphic report called "soup ticket".....	172
"31" forms.....	124
"31" orders containing the "X".....	129
"31" train orders.....	121
"31" "X" order.....	128-167
"31" "X" schedule order.....	132
"31"-"X"-"13" orders.....	163
"3" or "OS"-ing.....	75
"Through," meaning of.....	185
Time filed.....	57
Time orders.....	135
Tolls, amount of on envelopes.....	221
Torpedoes.....	112
Train, annulling a scheduled.....	137
Train order forms, standard.....	133
Train orders, form of.....	133
Train report, "detail".....	170
Train report, "detail" or destination.....	173
Train terms.....	91
Trains by orders, rules for movement of.....	76
Trains, how designated by orders.....	88
Translation.....	35
Transmission, duplicate.....	189

# INDEX.

249

	PAGE
Transportation, no promises as to .....	226
Uncollect message .....	186
Undelivered messages .....	223
Vouchers .....	234
Whistle signals .....	112
White signals .....	113
Wire testing .....	24
Wire testing abbreviations .....	68
Words for practice .....	44
Words of unusual spaces .....	42
Words to be counted and charged for .....	216
Work .....	147
Work train orders .....	136
Wrong address .....	225
Wrong address message .....	184
"X" .....	84
Yard message .....	98

