

FIVE-YEAR PIGON-RACING AT HORNER WOOD HOUSE.



THE
SHOT-GUN
AND
SPORTING RIFLE:
AND
THE DOGS, PONIES, FERRETS, &c.

USED WITH THEM IN THE VARIOUS KINDS OF SHOOTING
AND TRAPPING.

BY STONEHENGE,
AUTHOR OF "BRITISH RURAL SPORTS,"
EDITOR OF THE "FIELD," ETC. ETC.

~~~~~  
Illustrated with numerous Engravings.  
~~~~~

SECOND EDITION.

LONDON:
ROUTLEDGE, WARNE, AND ROUTLEDGE,
FARRINGTON STREET.
NEW YORK: 56, WALKER STREET.
1862.

[The Author reserves the right of Translation.]

SG2155.19.2
✓

LONDON:
SAVILL AND EDWARDS, PRINTERS, CHANDOS-STREET
COVENT-GARDEN.

67-★153

P R E F A C E.

THE circumstances which have led to the publication of this treatise on the *Shot-gun and Sporting-rifle* are as follows:—

At the close of the year 1857, on undertaking the editorship of the department of the *Field* connected with shooting, I found its columns deluged with an angry correspondence on the comparative merits of the breech-loader and muzzle-loader—statements and counter-statements were made, week after week, all of which could not possibly be true, since many of them were in direct opposition to each other. Theories were propounded of the most visionary kind, yet, as generally happens, their inventors expected them to be received as conclusive of the opinion to support which they were brought forward. The battle had raged for several months; but after all this

“Bubble, bubble,
Toil and trouble,”

no one was convinced, and the question was left exactly where it was when the correspondence commenced. But, as numerous good sportsmen seemed really desirous of ascertaining with something like exactness the real merits of these guns, it was determined to give them a public trial,

and the task of making the arrangements was undertaken by myself. The two gun trials of 1858 and 1859 were carried out with great care and trouble, and the real pretensions of muzzle-loaders and breech-loaders have been settled for the present to the satisfaction of all reasonable men.

As a natural result I have been brought into contact with guns and gunmakers in an unusual degree, and have had far greater opportunities of seeing varieties of principle and workmanship in this department of art than any other person out of the trade. Of course I do not claim to be acquainted with the details of the workmanship of guns and rifles to the extent which ought to pertain to the working gunmaker, whose life has been engaged in the mastery of them. The view which I have taken is that of the sportsman; but having been all my life of a somewhat mechanical turn, I may perhaps have been more capable of fathoming the secrets of the trade than others who have no taste that way. Where those secrets have been openly and fairly obtained by my own resources, I have not hesitated to lay them before my readers; but there are many others which have been communicated freely to me by gunmakers, without the slightest idea on their part of having them published, and these I have thought myself compelled to confine to my own breast. They are chiefly, however, connected with matters of no practical interest to the sportsman, and can only be useful to the actual makers of the gun.

For the opinions which are freely expressed throughout the book in reference to the various inventions I am alone responsible, no person connected with the gun trade having had the remotest influence upon them. Indeed, I have so

cautiously abstained from any risk of bias in favour of particular interests, that even in the descriptions of the mechanical details of gunmaking I have not availed myself of the supervision of a professed gunmaker, although I might easily have obtained that assistance. This may possibly lead to some slight errors of commission or omission; but I considered that it would be better to run the chance of these than to incur the suspicion of a tendency or leaning in some direction or other, which would probably be manifested. The book is, indeed, to be regarded more as a description of the various shot-guns and rifles after they are made than of the processes by which they are brought to the state in which they are offered to the public.

In addition to the three books on *The Theory of Gunnery*, on *The Shot-gun*, and *The Sporting-rifle*, three others are appended, on *Game*, *The Animals used in Pursuit of it*, and *The Methods of Preserving it from Vermin and the Poacher*. Finally, a short chapter on the *present Game Laws* closes the volume, which it is thus hoped will be made a full compendium for the shooter.

Most of the originals for the various elaborate drawings and sections of the guns included in this volume have been kindly lent me by their makers or inventors, to whom I beg to offer my thanks for their courtesy and constant readiness to afford to me every assistance in their power.

STONEHENGE.



CONTENTS.

BOOK I.

VARIETIES OF SHOOTING.

CHAPTER I.—INTRODUCTORY.

	PAGE
General Remarks—First Lessons in Shooting—Hedge Popping— Rook Shooting with the Shot-gun and Rifle	1

CHAPTER II.—PIGEON AND SPARROW TRAP-SHOOTING.

Remarks—Laws of Pigeon Shooting—Practical Directions for Pigeon and Sparrow Trap-shooting	7
--	---

CHAPTER III.—OPEN SHOOTING.

Grouse Shooting—Partridge Shooting—Snipe Shooting	14
---	----

CHAPTER IV.—COVERT SHOOTING.

Pheasant Shooting—Cock Shooting—Rabbit Shooting	56
---	----

CHAPTER V.—WILDFOWL SHOOTING.

Shooting Flappers—Inland Winter Shooting—Marine Wildfowl Shooting	78
--	----

CHAPTER VI.—RIFLE SHOOTING.

Objects for which the Rifle is Used—Target Shooting—Rook Shooting—Rabbit Shooting—Deer Stalking	93
--	----

BOOK II.

THE ANIMALS USED BY THE SHOOTER, AND THEIR
MANAGEMENT IN THE KENNEL AND THE FIELD.

CHAPTER I.

	PAGE
Pointers (Spanish and English)—Setters (English, Irish, and Russian)—Introductory Remarks on Breaking—Preparatory Education—Breaking at Pairing Time—Autumnal Breaking to the Gun—Remedies for Faults	113

CHAPTER II.—FIELD SPANIELS AND THEIR BREAKING.

General Remarks on Springers and Cockers—The Clumber and Sussex Spaniels—The Norfolk and other Breeds—The Welsh and Devonshire Cocker—The King Charles and Blenheims—Hunting Spaniels by Foot-scent—All Taught to Retrieve—Preliminary Education—Entering and Breaking	135
--	-----

CHAPTER III.—RETRIEVERS AND RETRIEVING BOTH ON
LAND AND IN THE WATER.

Land Retrievers—The Deer-hound—The Small Newfoundland Crossed with the Setter—The Cross with the Pointer and Terrier—The Beagle and Terrier Cross—Water Retrievers—The Pure St. John's Newfoundland—The Pointer and Terrier Cross—The Water Spaniel—English and Irish—Teaching to Retrieve on Land—And on Water	143
---	-----

CHAPTER IV.—RABBITING—RABBIT DOGS—FERRETS
AND FERRETING—SHOOTING PONIES.

Rabbit Terriers—The English Terrier—The Scotch Dog—The Dandie Dinmont—The Skye Terrier—The Half-bred Dog—Ferrets used in Aid of the Gun—Description—Rearing and Feeding—Diseases—Management in Hunting	150
--	-----

CHAPTER V.—GENERAL MANAGEMENT OF SHOOTING DOGS.

kennels and Kennel Management—Feeding—Dressings and Physic—Preparation for Work—Management after Work	158
---	-----

BOOK III

ELEMENTARY PRINCIPLES OF GUNNERY AND COMPOSITION OF THE PARTS ESSENTIAL TO IT.

CHAPTER I.—DEFINITION OF GUNNERY AND GUNS AS APPLIED TO SPORTING PURPOSES.

	PAGE
Gunnery in the Nineteenth Century as Applicable to Sporting Purposes—Classification of Modern Guns and Rifles—Shot-guns consist of a Tube more or less Cylindro-conoidal, capable of being Closed at one End—Barrels—Locks—Modes of Exploding—The Desiderata in the Shot-gun—The Rifle	168

CHAPTER II.—ON THE ACTION OF GUNPOWDER AND OTHER EXPLOSIVE COMPOUNDS.

General Remarks—Action of the Powder on the Projectile—Mode of Determining its Velocity—Epreuves—Resistance to the Motion of Projectiles through the Air—Recoil—Composition of Gunpowder and Gun-cotton, and the Materials used for Firing them by Percussion	178
---	-----

CHAPTER III.—ON THE VARIETIES OF PROJECTILES AND THE SUBSTANCES USED IN AID OF THEM.

All Sporting Projectiles made of Lead—Either Cast or Pressed as in Balls, or Dropped from a Height as in Shot—Shapes of Balls—Sizes of Shot—Wadding and Patches—Cartridges	207
--	-----

BOOK IV.

THE VARIETIES OF SHOT-GUNS AND THE ACCESSORIES
USED WITH THEM.

CHAPTER I.—THE PARTS COMMON TO ALL SHOT-GUNS.

	PAGE
General Remarks—The Barrel—The Breech—Proving—The Lock—The Stock—The Trigger and Guard—Percussioning—Case-hardening—Browning—The Cleaning-rod and Ramrod . . .	212

CHAPTER II.—THE MUZZLE-LOADING PERCUSSION GUN.

The Barrel—Various Kinds of Breech—The Lock—The Stock—Ramrod—Or Loading-rod—The Entire Percussion Gun and its Performances—Loading and Cartridges—Cleaning—The Gun-case and its Contents—Price of Guns	233
--	-----

CHAPTER III.—BREECH-LOADING GUNS.

General Principles—The Lefauchaux Gun—Various Modifications of it—The Needle-Gun of Needham—Lancaster's Combination of the Two—Count Chateauvillier's Gun—Choice of Breech-loader—Loading of Cartridges—Cleaning	254
--	-----

CHAPTER IV.—PUNT-GUNS.

Colonel Hawker's Punt-Guns—Breech-loading Punt-Guns	299
---	-----

CHAPTER V.—ON THE CHOICE OF GUNS AND THE MODES
OF TRYING THEM.

Desiderata in the Shot-gun—Weight—Length—Pattern—Penetration—Absence of Recoil—Safety—Quickness of Loading—Result of the <i>Field Gun Trial</i> of 1859—Breech-loaders <i>versus</i> Muzzle-loaders	301
---	-----

BOOK V.

THE SPORTING RIFLE.

CHAPTER I.—THE THEORY OF RIFLE SHOOTING, AND
THE MODE OF RIFLING THE BARREL.

	PAGE
Definition of the Rifle—Velocity diminished by Rifling a Smooth Bore—Greatest at the moment when the Ball leaves the Muzzle—Varieties in the Form of the Grooves almost Infinite—The Barrel—Method of Rifling—Technical Terms	311

CHAPTER II.—THE MUZZLE-LOADING SPORTING RIFLE.

General Remarks—Purdey's Two-grooved Rifle—The Single and Double Belted Ball—The Enfield Rifle and Pritchett Ball—Lancaster's Oval Spiral—General Jacob's Four-grooved Rifle—The Four and Five-sided Bore, with Rounded Angles of Major Nuthall and Mr. Boucher—Whitworth's Hexagonal Rifle—Henry's Rifling—The Ratchet-Wheel Groove—Varieties of Balls—Single and Double Rifles	321
--	-----

CHAPTER III.—BREECH-LOADING RIFLES AND REVOLVERS
APPLICABLE TO SPORTING PURPOSES.

General Remarks—Prince's Rifle—Terry and Calisher's—Restell's—Leitch's—Westley Richards'—The Lancaster—Needham's—The Lefauchaux—Bastin's—Gilbert Smith's—The Field Rifle—Wilson's—Mackenzie's—Pea Rifles—Sharpe's—Revolvers	336
---	-----

CHAPTER IV.—THE ACCESSORIES OF THE RIFLE.

Bullet Moulds—Casting Bullets—Swedging Machine—Patches—Cartridges—Sight Guards—Ramrods—Plain and Telescope Sights—Rifle Powder—Flask—Rests	366
--	-----

CHAPTER V.—CHOICE OF A RIFLE FOR SPORTING
PURPOSES.

Requisites for a Sporting Rifle—Comparison of the Three Principal Kinds—Final Choice	379
--	-----

BOOK VI.

THE GAME PRESERVER'S GUIDE.

CHAPTER I.—DUTIES OF THE GAMEKEEPER.

	PAGE
Onerous Nature of the Task—Honesty—Knowledge of Law necessary—Numbers required—The Keeper's Gun—Selection of Preserve or Shooting—Contracts for taking Moors or Manors—Certificate	387

CHAPTER II.—REARING GAME.

The Kinds which can be reared artificially—Methods of obtaining Eggs—Hatching—Rearing—Keeping Tame Pheasants—Turning Out—Rearing Game in a Wild State	394
---	-----

CHAPTER III.—VERMIN AND THE MODES OF DESTROYING THEM.

The Cat—Marten—Fox—Polecat—Stoat—Weasel—Rat—Hedgehog—Eagle—Kite—Peregrine Falcon—Buzzard—Marsh Harrier—Hen Harrier—Montague's Harrier—Sparrow Hawk—Hobby—Merlin—Kestrel—Barn Owl—Brown Owl—Raven—Crow—Hooded Crow—Jackdaw—Magpie—Jay—Traps and Trapping—The Vermin Terrier—Poison, and the Mode of laying it	407
--	-----

CHAPTER IV.—POACHERS, AND THE BEST MODES OF COUNTERACTING THEIR SCHEMES.

General Remarks—Labourers the best Preservers of Game, as they are also the worst Poachers—The Certificated Poacher—The Regular Poacher, and his Proceedings	442
--	-----

CHAPTER V.—THE GAME LAWS.

General Remarks—English Game Law of 1831—Law for permitting the killing of Hares in England—Scotch Law, including that permitting the killing of Hares, and also the Law of Trespass—Irish Game Laws—New Game Licence Acts	449
--	-----

LIST OF ENGRAVINGS.

GUNS, PLANS, ETC.

FIG.	PAGE
1. Target Rifle Shooting	95
2. The Puzzle Peg	133
4. Ferret muzzle	155
5. Ditto	156
6. Gun Gauge	172
7. Ballistic Pendulum	183
8. Gun Carriage	196
9. Powder Flask, Shot Pouch, and Cap Holder	211
10. Bar of Damascus Iron	214
11 a. Damascus Barrels	215
11 b. Fine-grained Damascus	215
11 c. Imitation Damascus	216
12. Stub Twist	216
13. Laminated Iron	217
14. Stub Damascus	217
15. Charcoal Iron	218
16. Twopenny Iron	219
17. Sham Damn	219
18. Breadth of Rod in best Guns	220
19. Breadth of Rod in common Guns	220
20. Provisional Proof Marks	226
21. Definitive Proof Marks	226
22. Stock with Safety Guard	228
23. Safety Guard	230
24. Modern Breech	234
25. Joe Manton's Breech	234
26. Nipples	236

FIG.	PAGE
27. The Greener-Horton Breech	237
28. Percussion Gun Lock	238
29. Lock Plate and Bridle	238
30. Striker and Tumbler	238
31. Mainspring and Swivel	239
32. Spring for Tumbler	239
33. The Lefauchaux Gun	256
34. Back-acted Lever	257
35. Section of Loaded Cartridge and Chamber	258
36. Bastin's Breech-Loader	263
37. Bastin's Gun, open	264
38. Lever and Slide to Bastin's Gun	265
38*. Dougall's Lock-Fast Breech-Loader, open	268
38**. Longitudinal Section of Dougall's Gun, and Plan of Eccentric Bolt	269
39. Needham's Needle Gun, closed	271
40. Breech Plug and Lock, screwed up	272
41. Breech Plug and Lock-cylinder	272
42. Under surface of Barrels	273
43. The Needle	275
44. The Mainspring	276
45. The Screw Cam	276
46. Scar-Spring, Scar, and Trigger	276
47. The Bolt	277
48. Section of Loaded Cartridge	278
49. Loaded Cartridge	278
50. Lancaster's Gun, closed	281
51. Cartridge Extractor	281
52. Lancaster's Shot-gun	282
53. Face of False Breech	284
54. Side View of Needle	284
55. Perforated Copper Disc	285
56. Section of Loaded Cartridge	285
57. Cartridge-case	286
58. The Chateauvillier Needle Gun	287
59. Chateauvillier Gun, open	288
60. Section of Chateauvillier Gun, with a perspective View of the Locks	289
61. Trulock and Harris's Cartridge-loading Tool	292
61* and 61**. Jeffries' Cartridge-filling Machine	293

LIST OF ENGRAVINGS.

XV

FIG.	PAGE
61***. Trulock and Harris's Recapping Machine	295
62. Bussey's Cartridge-holder	297
63. Shoulder Duck Gun	299
64. Needham's Breech-loading Punt Gun	300
65. Results of Shooting at Various Distances	314
66. Rifling Machine	318
67. Driving Wheel of Rifling Machine	319
68. Double-barrelled Purdey Rifle	322
69. Single Purdey Rifle	322
70. Section of Purdey Rifle, and view of Ball	323
71. Belted Spherical Balls	323
72. Major Nuthall's Rifle	326
73. Mr. Boucher's Ball	326
74. Section of Mr. Boucher's Rifle	326
75. Whitworth's Hexagonal Ball (reduced in size)	330
75°. Present Whitworth Bore and Ball, full size	331
75**. Section of Henry's Rifle, full size	332
75***. Ratchet-Wheel, or Feather-edged Groove	333
76. Greener's Bullet	333
77. Crenulated and Plain Cylindro-Conoidal Balls	334
78. Pritchett's Bullets	335
79. Prince's Rifle, closed	337
80. Prince's Rifle, open	338
81. Under side of Prince's Rifle	339
82. View of Terry and Calisher's Rifle	340
83. Section of Terry and Calisher's Rifle	341
84. Restell's Rifle, open	345
85. Leetch's Rifle, opened for Loading	346
86. Westley Richards' new Rifle, open, and section of the Barrel	347
87. Westley Richards' Rifle, closed	348
88. Gilbert Smith's American Rifle	354
88°. Field Rifle, closed	356
88**. Field Rifle, open, with the Plunger and Cylinder shown separately	356
88†. Mackenzie and Wentworth's Rifle, closed	358
88††. Mackenzie and Wentworth's Rifle, open	359
88‡. Rigby's Needle Pea-Rifle and Cartridge	360
88‡‡. Rigby's Needle Pea-Rifle, open for Loading	361
89. Dean's Revolving Rifle	364
90. Lock, Cylinder, and Trigger of Dean's Revolver	365

FIG.	PAGE
91. Greenfield's Swedge	370
92. Patch Cylinder	372
92*. Captain Jaques' Sight Guard and Regulator	375
93. Captain Conolly's Rifle Rest	378
94. Pen for young Pheasants	400
95. Hurdle for Pheasant Pen	403
96. Inhaler for Gapes	405
97. Hawk Trap	431
98. View and Section of Box Trap	432
99. Ground Plan of Box Trap	433
100. The Mock Pheasant	447

ANIMALS, ETC.

	FACING PAGE
Pigeon Shooting at Hornsey Wood	12
Group of Pointers	113
——— Setters	115
——— Springers	135
——— Cockers	136
Deerhounds	143
Retrievers	144
Water Spaniels	146
Rabbit Terriers	150
White and Dark Ferrets	152
The Marten and Polecat	408
The Stoat and Weasel	410
The Kite	413
The Peregrine Falcon	415
The Buzzard	416
The Hen Harrier	418
The Sparrow Hawk	419
The Hobby	420
The Merlin	421
The Kestrel	422

THE
SHOT-GUN AND SPORTING RIFLE.

BOOK I.
VARIETIES OF SHOOTING.

CHAPTER I.

INTRODUCTORY.

GENERAL REMARKS—FIRST LESSONS IN SHOOTING—HEDGE POPPING—
ROOK SHOOTING WITH THE SHOT-GUN AND RIFLE.

THE object of the following pages is to afford assistance to the young sportsman in the use of the shot-gun and rifle, and in the selection of the kinds of each best suited to the particular sport which may be chosen for his amusement. It must be obvious, that in the early stages of this inquiry something must be taken for granted, because, without a knowledge of the exact purposes for which a gun is wanted, it cannot be advantageously chosen; and, in the same way, those purposes cannot be fully entered into, unless the reader is acquainted with the accessories to his sport which may be essential to it. For the sake of convenience, the plan will be here adopted of giving a general description in Book I. of the various kinds of shooting; the more detailed particulars of the dogs, guns, rifles, &c., employed being added in the subsequent books.

Whenever, therefore, the reader wants to know, for instance, how to load his gun or rifle, or the kind best suited to his purpose, he must search in Book IV. for what he wants; while the dogs, ponies, &c., used with the gun, will

be found described at length in Book II.; and the best modes of trapping vermin, and of rearing and preserving game in the SIXTH BOOK. It will thus be made clear, that in the present book I shall proceed to describe in general terms only the various sports known as grouse and partridge shooting, covert shooting, &c., giving such particular directions as will enable the tyro to master each, and beginning with those methods which are the most easily practised, and which are, at the same time, the most likely to make him ultimately expert in all branches of shooting.

FIRST LESSONS IN SHOOTING.

Before the intending shooter ventures to practise upon any living object, he should make himself completely master of the tool which he is to employ. It is not necessary, perhaps, in all cases, that he should understand the mechanism of its locks, or that he should know how it has been constructed; but he should, at all events, have learned how to load his gun or rifle in a safe and proper manner, and the best and safest mode of putting the various parts together, as he takes them out of his gun case. For the purpose of gaining this information he will do well to consult some experienced person, from whom he will readily learn by demonstration that which would possibly take him a long time to acquire from the pages in which it is described in its proper place in this manual. But in whichever mode the knowledge is to be obtained, it is absolutely essential to the safety of the shooter and his friends that it should not be neglected; and until he has learnt to put his gun together; to cock and uncock it, to load it and to discharge it properly, he must carefully avoid using it indoors or out. At the same time he should diligently study the following general rules for the prevention of accidents, which should never under any circumstances, or with any gun, be overlooked:—

1. Never let the muzzle of the gun be pointed at any living object, excepting that which is intended to be hit.

2. In carrying the gun three positions only are allowable, excepting at the moment of firing. *Firstly*, with the trigger-guard on the forearm, and the muzzle pointing

towards the ground. *Secondly*, with the stock in the hand, the striker resting against the shoulder, and the muzzle pointing towards the sky. And, *thirdly*, with the hands laying hold of the gun as in the position for firing, but with the stock against the right hip, and the muzzle pointing towards the sky. This last is the proper position at the moment when a shot is anxiously anticipated, as in walking up to dogs pointing, or when expecting rabbits to cross a narrow ride.

3. The directions for loading must vary according to the kind of gun used, the precautions proper to the muzzle-loader being quite useless if applied to the breech-loader. The young shooter is therefore referred to the directions for loading each in their proper places.

4. Every kind of gun with which I am acquainted may be left at half-cock, or bolted in a corresponding manner; and this is the safest position for it to be in when not immediately wanted. It is of the greatest importance that the tyro should practise the cocking and uncocking of his gun, so as to be certain that he can accomplish it without any chance of the cock slipping from his fingers, and at the same time to avoid a partial cocking only, by which the striker, or cock, is only slightly held in its place, and is liable to slip down and cause a discharge on the slightest jar. The *cause* of this will be fully explained hereafter; but in practice all that is necessary is to take great care that the striker is *raised* to the half-cock, when there will be a peculiar click heard and felt. In letting down the lock from "full-cock" to "half-cock," the striker must be suffered to pass this notch, the finger being on the trigger, and when well below it must be brought up again till it is securely fixed.

5. Take care that the charge does not become loose in the barrel, from the wads being too small for its calibre. Avoid also any chance of snow or dirt getting into the muzzle. A neglect of any of these precautions may lead to the bursting of the gun.

TAKING AIM.

When the gun is thus mastered in the hand, the next thing to be done is to make the hand and eye combine together to take an aim, which may be either at a fixed

(dead or sitting) shot, or at a moveable one, as at a bird flying or a hare running.

In learning to hit a dead mark, which is usually the first step in shooting, the gun may be made familiar to the eye in-doors as well as out; and with the ordinary percussion gun practice may be afforded with a cap only, which will put out a candle at the distance of a couple of yards. A small bore (16 or 18) should be chosen, and then putting the cap on, the gun is brought up to the shoulder, and carrying the eye along the barrel when the "sight" is seen to cover the candle, the trigger is pulled smartly, and if correctly aimed the light is extinguished. By repeating this again and again until the feat is performed with certainty and celerity, a sufficient amount of control over the gun is obtained, which will be found to serve the purpose of facilitating the subsequent stages. Next load the gun with a small charge, say two drachms of powder and three-quarters of an ounce of shot, and then carrying the left hand well forward beneath the barrel, so as to steady the aim, point the gun in the same way as before at some fixed object thirty yards off. This should be surrounded by a flat surface, which will show the whole pattern made by the shot; and if these are scattered pretty nearly all round the central point, the aim has been a good one. On the other hand, if there are more on one side than the other, there has been some fault committed, and the tyro must repeat his effort till he has acquired skill enough to throw the centre of his charge of shot on the object of his aim. It seems a very simple process to do this; but the beginner will find that it will take him some days to master it satisfactorily, and until he has succeeded in this, he should not attempt more. He must remember that at thirty or forty yards the circle well covered by his shot is from forty to thirty-six inches in diameter; and therefore it does not follow that because he kills a bird sitting on a post at that distance, he has really aimed correctly at it. It may have happened that the centre of the charge was nearly two feet on one side of it, but a stray shot on the outside proved fatal, and so his luck, and not his skill, served him. Hence an iron plate whitewashed, with a black centre, or a large sheet of paper having also a mark in the middle, will form

a far better target for practice than any small bird or other similar object, which is nevertheless much more tempting to the eye.

Shooting flying is a much more difficult art, and a long apprenticeship is necessary to acquire it. Considerable difference of opinion exists as to the use of both eyes in this kind of shooting, or of the right one only; but my own belief is that few people really use both at the moment of shooting, even if they keep them both open. But, whether shutting the left or not, there must be no attempt at looking along the barrel, the correct pointing of the gun being acquired by looking at the object to be shot at, and then *instinctively directing the gun towards it*. In doing this the line of sight must coincide nearly with the upper surface of the barrel, if the butt of the gun is at the shoulder. Still the eye must not be taken off the object to look along the barrel, or the aim will be imperfect, and the shot probably a "miss." It is quite true that some sportsmen adopt the opposite plan, and invariably wait till they can bring the "sight" to cover the object aimed at; but they are always slow shots, and are almost sure to shoot behind every variety of bird or ground game crossing them; because in this case they should aim in front, proportioning the extent according to the velocity at which the animal is moving. I have heard of an instance in which a partridge flying down wind, was killed at a distance (carefully measured) of one hundred yards from the shooter, who assured me that he aimed, as he thought, fully five yards in front of the bird as it was crossing, and flying exactly parallel with the opposite hedge into which it fell. A very good plan for beginners is to get a friend to throw a potato or turnip into the air, varying its direction at each throw. It should not be sent directly up into the air, because there is then a moment of time at which it is stationary, and may be hit almost as easily as a dead mark; but by throwing straight away, or from left to right and *vice versa*, the flight of birds may be imitated, and the shooter may obtain practice in everything but the excitement produced by the "whirr" of the partridge or pheasant, to which, however, he must accustom himself by practice before his nerves will be steady enough to allow him to shoot well.

HEDGE POPPING.

When the potato can be pretty certainly hit, let the young shooter try his hand at any bird flying by in the fields, hedges being generally beaten for this purpose; or if he has no opportunity for this, let him procure some sparrows, and shoot them either from the hand or from a trap, such as is used in pigeon trap-shooting (which see p. 14). Should the sparrows be too quick, put their heads through a hole in a small piece of paper, which will retard their flight, and in course of time practice will enable this to be dispensed with. Swallows are bad marks because they are occasionally almost still while hawking, and can then be readily shot. In every case the shooter must endeavour to aim in front of a bird or other animal moving quickly, and for most birds of tolerably quick flight, at forty yards' distance a foot will not be too much to allow on the average. So also in animals approaching or leaving the gun, the aim must be over them, or they will inevitably be missed. With these directions, if patiently and assiduously carried out, the young sportsman will only want to acquire steadiness of nerve to become as skilful in shooting game as, after proper practice, he ought to be in dropping sparrows and other birds of similar small value.

ROOK SHOOTING WITH THE SHOT-GUN AND RIFLE.

Rook shooting with the shot-gun is an amusement which will be of little service in improving the young sportsman, because he will get few flying shots, and those at sitting birds are of very little more use in giving him practice than a target, or a sparrow on the housetop. Young rooks are on the average of seasons out of the nest towards the middle or end of May, and just before they can fly from the trees is the time generally seized by those who care about the "bag." If left till they can fly well, the first report of the gun or rifle sends them all off out of shot, and hence the air-gun and cross-bow are occasionally selected for rook shooting on account of their noiseless action. But even with the gun a

flying shot may occasionally be obtained, and no sportsman worthy of the name would think of shooting at rooks while sitting, excepting with the object of filling a pie. A strong shooting gun and No. 5 shot will be required, or a rifle of small bore specially made for rook and rabbit shooting, as will be explained under the head of **THE RIFLE**. When the latter is used, the rook may be shot sitting without any compunction, because, at one hundred yards, which is often the distance of the shooter from his mark, it is by no means easy to hit so small an object. With the shot-gun, on the contrary, the distance is the only difficulty, and it is often only by getting directly under the trees, that these birds can be brought within forty or fifty yards, which is a fair range for an ordinary gun. Eley's cartridges may be used even at one hundred yards, with a good prospect of cutting down young rooks; but unless the trees are low, when loose shot will succeed, I should strongly recommend the rifle, as being more sportsmanlike than the shot-gun. The particular kind of rifle suited to this purpose will be hereafter described.

CHAPTER II.

PIGEON AND SPARROW TRAP-SHOOTING.

REMARKS—LAWS OF PIGEON SHOOTING—PRACTICAL DIRECTIONS FOR PIGEON AND SPARROW TRAP-SHOOTING.

PIGEON SHOOTING for some years past has been confined to the frequenters of low public-houses in the large towns; but in the year 1858 the amusement suddenly became fashionable, Lord Huntingfield, the Earl of Stamford, the Hon. Dudley Ward, and Mr. Bateson, having repeatedly shot matches at Hornsey Wood House, which has now taken the place of the Red House, Battersea, once the scene of the triumphs of Mr. Osbaldeston, Captain Ross, and others of almost equal note. A great improvement has been intro-

duced by getting rid of the small cannon which were formerly in vogue, and substituting the ordinary sportsman's double-barrelled gun, with occasionally two birds to be shot at "right and left." Greater quickness than before even is consequently required in shooting; for not only has the shooter to take his first bird as soon as he can, but he has also to consider his second. The sport may now constitute pretty good practice preparatory to game-shooting; but it has the objection that it encourages quick shooting too much, and in the early part of the season it tends to lead the young sportsman astray. Still it gives considerable command over the second barrel, and, though a good pigeon shot may not be equally clever at grouse or partridges, he will assuredly be better after this practice than he was before. Sparrows are thought by some to be more useful than pigeons in teaching shooting; but the distance within which No. 7 or 8 will kill them with certainty is not more than thirty-five yards, and thus over-rapidity is still more likely to be acquired than in pigeon shooting.

LAWS OF PIGEON TRAP-SHOOTING.

The following rules are those usually adopted in the present day, but they are not received as generally binding; and in any conditions for a match or sweepstakes the rules by which the shooting is to be regulated should be distinctly specified:—

1. Two referees and an umpire to be chosen, whose decision shall be final.

2. A boundary to the shooting-ground must be provided, if not already in existence. It should be, if possible, a boarded fence or a wall, and situated at from eighty to one hundred yards from the traps. These should be placed at twenty-one to twenty-five yards from the shooter; and if five in number, in a curve before him, each being equidistant from the mark, and from five to six yards apart. In the conditions the number of traps should be specified, and whether they are to be pulled at discretion or by tossing; in the latter case, called H and T traps. A bird killed according to the conditions is scored "a fair bird;" if

not so killed, a "lost bird;" and if another is to be allowed, a "no bird."

3. The bore and charge of the guns to be used must be specified; also whether single or double barrels. Any shooter using a drachm more shot, or a bore of a size larger than that named, to be disqualified and forfeit his stake.

4. The shooter to call "pull" when he is at the mark ready to shoot. Should the trap be pulled without the word being given, the shooter may take the bird or not; but if he shoots, the bird must be considered taken. If the trap is pulled and the bird does not rise, it is "no bird" at the option of the shooter; but if he shoots at it either on the ground or trap, or after it rises, and *miss*, it is to be scored "lost."

5. A bird must be shot while on the wing in order to score a "fair bird," excepting with the second barrel in double guns, and it must be gathered before passing the boundary either by the shooter or deputy. In doing this one person only must officiate, and he must gather the bird without the aid of any kind of implement. Should the bird perch on the boundary, and then fall back into the ground, it is "lost;" or if it should *perch* in any tree or building, and then fall to the ground, it is also "lost." But if a bird, so hard hit by the shooter that, in the opinion of the referee, it would have fallen within bounds, is shot at by a scout, the shooter may be allowed another bird on the order of the referee; but if a bird is palpably missed, the referee may give it as a lost bird, even if killed within bounds by a scout. A bird once beyond the boundary is "lost," even if it falls dead within it.

6. In case of a miss-fire another bird is to be allowed, if the gun was properly loaded and cocked, and the miss arose from the cap or other detonating material not exploding; but if, after giving the word "pull," the trigger is not pulled, or the gun is not properly loaded and capped, or does not go off owing to the shooter's own negligence, the bird is to be scored "lost."

7. If, in the opinion of the referee, the shooter is mechanically balked by his antagonist, or by any person other than his own backers, he may be allowed another bird.

8. Neither of the shooter's feet is to extend beyond the shooting mark, under any pretence whatever, until after his gun is discharged.

9. In single shooting, if more than one bird is liberated, the shooter may call "no bird" if he likes, and claim another; but if he shoots he must abide by the consequences. In shooting with H and T traps, according to the toss, the trap H or T must be pulled at each shot.

10. In double shooting, when more than two traps are pulled, the shooter may call "no bird," and claim two more; but if he shoots he must take the consequences.

11. Either party may, on depositing a sovereign in the hands of the referee, claim to have the charge of his antagonist drawn; but if it should prove not to be over the stipulated weight, he must forfeit the sum so deposited to his opponent.

12. Each shooter in a match or sweepstakes to be at the shooting mark at the expiration of five minutes from the last shot. But, in case of accident, he may claim an extra quarter of an hour once in the course of the match.

13. In case of a tie between two or more in a sweepstakes, it must be shot off during the same day, if there is sufficient light, unless the prize is divided by agreement. If, through want of light, it cannot be finished at once, it must be shot off on the first available day.

PRACTICAL DIRECTIONS FOR PIGEON AND SPARROW TRAP-SHOOTING.

The gun for pigeon shooting should be a very hard hitter, for these birds, when really strong "blue rocks," will take a great deal of killing. For double shots, which of course require two barrels, the usual bore selected is 12, and the charge $2\frac{3}{4}$ to 3 drachms of powder and $1\frac{1}{2}$ to $1\frac{1}{4}$ ounce of shot, which may be No. 5 or 6, at the fancy of the shooter. If he is a very quick shot, and takes his bird at or very near to the trap, No. 6 will suit him well for his first barrel and No. 5 for his second. But a slow shot will do better to load both his barrels with No. 5. In Book IV., the question relating to muzzle loaders *versus* breech loaders will be fully

considered; but I shall here remark that the latter kind can pretend to no advantage over the former in pigeon shooting, while it is still doubtful whether it quite comes up to it in strength of shooting. Most professed pigeon-shots, therefore, use the muzzle-loader; but certainly I have seen very good work done with the new kind of gun.

The kind of pigeon which is considered the best is the "blue rock," a fast and very hardy bird, which appears to be the nearest approach to the wild rock pigeon or dove, and is or should be marked and coloured like that bird. Many other varieties of the common domestic pigeon are, however, very generally used in pigeon matches; but if the conditions specify "blue rocks only to be used," the birds should answer to the following description:—Beak reddish brown; iris pale orange, approaching to yellow; head and neck bluish grey, the sides of the latter with green and purple iridescent reflections; shoulders, upper part of the back, and wing-coverts grey, the greater coverts having a black bar near the end; primary and secondary quill feathers bluish grey; tail feathers twelve, both ends being light grey, with a lead-grey middle; throat purplish green; all the under parts pearl grey; legs and toes reddish brown; claws brown. If the pigeons are not of a good sort, or are obtained from inn-yards or other places where they become tame, they do not fly the moment the trap is pulled, nor do they go off at a fast pace. Hence the person who supplies them ought to be particular in obtaining them from retired farm-houses, and it is no uncommon thing for Barber (the chief London purveyor) to send 200 miles for such birds before a great match. The usual price in London is 14s. to 15s. a dozen, but in the country they may often be obtained at 6s. One of the most common tricks played off upon the match-shooter is by means of this difference in the birds, where the person who pulls the string is aware of the quality of each. Thus, supposing he sees that certain traps contain strong birds, and others the reverse, he pulls the latter for the shooter that he wishes to favour, and reserves the former for his opponent. Hence it should always be a condition that each shooter should pull for his opponent either by himself or a deputy, and this plan would tend to prevent occasional trickery, and still more

frequently complaints of it without foundation. Just before putting the birds into the trap, it is usual for the man to pull a few feathers from the tail coverts, which is done to make them lively, and thus go off keenly. Sometimes, however, one or two wing-feathers are included in the pull, with the intention of causing the flight to be slow, and for the purposes of fraud; but the person supplying the birds generally knows the quality of each too well to require to have recourse to so clumsy an expedient.

In gathering a doubtful bird, great quickness of eye, legs, and hand are required; for it often happens that one will drop from a momentary stunning without being winged or mortally wounded in the body or head. In such a case, the moment the man approaches within a yard or two, the pigeon rises, and probably just scrambles over the boundary. The skilful gatherer creeps stealthily and in a crouching attitude up to within a couple or three yards of his victim, when stooping as low as he can without interfering with the action of his legs, he rushes with a short and very quick action of them to and by the bird, and while passing, picks it up by the head, or sometimes, when he has a large hand, by the back, just behind the wings. To do this neatly requires great practice, and as it is of considerable importance to success in a match, a good gatherer is highly valued and proportionally paid. Dogs are sometimes used to retrieve pigeons, but they are not nearly so clever as such active men as the son of the celebrated Barber, the well-known London purveyor of pigeons.

The attitude in shooting varies according to the number of traps used. Thus with one or even two traps only, it is customary to adopt the ordinary shooting attitude, with the left leg advanced; but where five traps are used, this position does not give a sufficient command of ground, the five traps nearly occupying a fifth of the surrounding circle. Hence the skilful pigeon-shot stands square to the front, with both toes touching the mark, and with heels about two feet apart, more or less, according to his height. In this position, being opposite the centre trap, he can turn either way equally well; and it is found that it gives him far more facility, especially in using the second barrel, than the ordi-

nary shooting attitude. Formerly it was the custom to make it a rule that the gun should be held below the shoulder until the trap is pulled, but this led to so many wrangles, and on the whole there is so little gained by having the gun up, except with single traps, that there is now no restriction whatever. When one trap only is employed, which is very rarely the case in a match, the gun certainly ought not to be at the shoulder, because the shooter then covers the trap, and the moment it is open and the bird rises, he pulls, with a great chance of killing, especially if the bird goes straight away. If, however, it flies right or left, there is no great advantage, even with one trap. When five are used, it is a positive disadvantage to the shooter, unless there is collusion between him and the puller of the traps, who may in some way indicate which he is about to pull, and then the gun may cover that one in readiness each time. Or the shooter may make his selection, and the puller, seeing which he covers, may give him that bird every time; and this trick I have certainly seen played on more than one occasion. Where, however, there is any positive fraud practised, it is more commonly done by means of the quality of the birds used for each of the antagonists. It is to avoid these several chances of trickery that it is sometimes arranged for each shooter to pull for his antagonist, and certainly there can be no objection to the plan if both are skilful enough to execute it well; but it requires some little practice to avoid showing beforehand which string is going to be pulled, and at the same time run no risk of pulling more than one.

In shooting at pigeons when they turn right or left, the gun must be aimed considerably in front of the bird, if it is a fast one, and turning either way, and over its back if going straight away. Where two barrels are allowed, and the bird is not killed dead, the second should be given as soon as possible if the wing is not evidently broken; for otherwise it may get out of shot, and the second barrel is then useless. So also if the bird is hit and not disabled, and dropping to the ground, walks deliberately away, the second barrel should be let go, or the distance may be too great when it rises. A shot on the ground, when a bird is without doubt hit, is permitted; and it reckons "dead," although it could probably have escaped the boundary if not shot a second time.

In sparrow trap-shooting, the rise is twenty-one yards, and the boundary from forty to sixty yards from the traps. The rules are the same as for pigeons in all other respects, and the directions for shooting will also apply, the sole difference being in the size of the shot, which may be No. 8, 9, or 10. When two barrels are used, No. 10, or even dust-shot may be employed for the first barrel if the gun scatters very much, and No. 8 or 9 for the second; but so much depends on the pattern made at thirty and forty yards by the gun intended to be used, that no positive directions can be given suitable to all cases. The best plan is to use the largest size which will cover a target sufficiently close to prevent a sparrow escaping at each of the above distances; and as this can readily be tried, the experiment should never be neglected. Sparrows often get away when hard hit with No. 9 or 10, which sizes do not always break a wing-bone at forty yards, and therefore, unless, as before remarked, the gun scatters very much, No. 7 or 8 should be preferred.

CHAPTER III.

OPEN SHOOTING.

GROUSE SHOOTING—PARTRIDGE SHOOTING—SNIPE SHOOTING.

BEFORE proceeding to describe the nature of each kind of shooting, it will be necessary to allude to the varieties of grouse, partridges, and snipe respectively, to the nature of their habitat, the dogs used in finding them, and the best kind of gun for killing them.

GROUSE SHOOTING.

The varieties of grouse which are met with in this country are four, but in America, and in other parts of the globe, they are vastly more numerous. Of these four the capercaillie is very rarely found in Great Britain, having only recently been

re-introduced into Scotland after being completely exterminated. It is, however, tolerably common in Sweden, but is every year becoming more and more scarce there. The black grouse (or black cock and grey hen, as the male and female birds are called) is, on the contrary, common enough; but the shooting of this variety is not to be compared with that of the red grouse, which is the kind usually meant in speaking of grouse or grouse shooting. Black grouse are met with in the south of England, as well as in the north; and in Scotland, and are also commonly found in Scandinavia, and occasionally in Russia, Poland, Germany, France, and Holland. On the other hand, red grouse are peculiar to the British isles, being found in England, Ireland, and Wales, as well as Scotland, which last has, however, given the distinctive name "Scoticus" to this species. Lastly, the ptarmigan, though occasionally met with in the Highlands of Scotland, is chiefly confined to still colder climes, being common in Sweden and Norway, from which many are annually sent to the markets of this country. The following is a more detailed description of each:—

The CAPERCAILLIE, WOOD GROUSE, or COCK OF THE WOOD (*Tetrao urogallus*) is so much larger than the other *Tetraonidæ*, while at the same time it has enough of the family character to identify it, that it is needless to occupy space in minutely describing its generic characters. Since the year 1760, or thereabouts, this fine bird has been quite unknown in Scotland, but after several failures in other hands, Lord Breadalbane has now succeeded in rearing a stock, which it is hoped may become completely naturalized in Scotland. In 1838 and 1839 Thomas F. Buxton, Esq., collected forty-four birds, two-thirds of which were hens, and presented them to his lordship, who turned some out into the forest, retaining the rest in a large aviary. Both sections bred well, and the stock is now greatly increased, but disease within the last few years has somewhat thinned their numbers again. There seems, indeed, to be no difficulty in rearing the capercaillie in confinement; the Duchess of Athol and the late Earl of Derby having each succeeded in effecting the object to some extent. It also freely breeds with the black grouse, the hybrid partaking of the characters of each. The male

bird is nearly as large as the turkey, the female being considerably less. The nest is made on the ground, and the hen lays about eight or nine eggs.

The BLACK GROUSE or BLACK-COCK (*Tetrao tetrix*), the female of which is the GREY HEN, is chiefly confined in Great Britain to Scotland, and the most northern counties of England; but it is also found in Sussex, Surrey, Berkshire, Hampshire, Dorsetshire, Devonshire, Somersetshire, Worcestershire, Staffordshire, and Shropshire. On the Continent it is common enough in the most northerly countries, especially Scandinavia and Russia. The *generic characters* are as follows:—Body of the male black, with a beautiful glossy blue over the neck and back; wing coverts brownish, greater coverts white, forming a white spot on the shoulder when the wing is closed; tail black, and much forked; legs and thighs covered with mottled feathers; toes toothed; the eye has a red spot above and a white one below it; weight about four pounds. The hen is only half the weight of the cock; in colour she is barred with dusky red and black above, and dusky red and white below; her tail is slightly forked, but not nearly so much so as that of the cock. The length of the black cock is twenty-two inches, of the grey hen seventeen to eighteen. The nest is made on the ground, frequently under a low thick bush, and with very few materials. The eggs are about six or eight in number, of a yellowish white, spotted and speckled with orange brown; they are two inches long, by one inch five lines. Black grouse do not pair, and the hens are not attended by the cocks from the time when the former begin to sit, after which the males assemble together, and until the latter part of the season are rarely seen to associate either with the young birds or with the old hens. In their first plumage all the young birds resemble the hen, but towards the end of August or the beginning of September, the young cocks moult and assume the black colour peculiar to the adult condition of the sex. While undergoing this transformation, these young birds are mottled with black, and look very ragged and patchy; but as the old cocks are tough and dry when dressed, these marks of youth are eagerly sought after by the gourmand. A young black-cock which has still a few grey feathers is in perfection, the

flavour of those with most of the grey feathers remaining being somewhat insipid. *The food* of the black-cock varies with the season ; in summer he feeds upon the tops of the heath, grass seeds, &c. ; in autumn berries of various kinds will be found in his crop, together with corn and other seeds in districts where this kind of food is plentiful ; lastly, in the winter, the young shoots of the various pine trees afford these birds the means of support in the absence of corn, which is, however, sometimes supplied to them in the same way as for pheasants. Black grouse breed both with the capercaillie and the pheasant, and even between them and the red grouse it has been asserted that in some rare instances a hybrid has been produced, one of which is figured in "The Moor and the Loch," by Mr. Colquhoun. There is also no doubt that a hybrid between the black grouse and subalpine ptarmigan has been met with, one of them being represented in Yarrell's "British Birds," at page 349, as a part of the fauna of Scandinavia, on the authority of M. Nilesen. Black grouse are easily reared in confinement, but require plenty of space.

The RED GROUSE (*Lagopus Scoticus*) is peculiar to the British isles ; in the higher and colder parts of which they are to be found, inhabiting wild and extensive heaths and moors. This species differs from the capercaillie and black grouse in pairing, while they are polygamous. Red grouse are found in coveys or packs throughout the winter ; in the early part of which each of these is composed of the two old birds and their young ones, called a covey ; but towards the latter part of the year several of these join together, sometimes to a number greatly exceeding that of one brood, and then properly denominated a pack. The nest is formed of hay and grass, arranged in a hollow of the ground, generally under a tuft of heather. The eggs are from eight to fifteen in number, the ground colour being reddish white, closely covered with blotches of umber brown ; length, one inch and three-quarters ; breadth, one inch and a quarter. The laying generally begins at the end of March, and is concluded towards the latter part of April or beginning of May. The young brood leave the nest as soon as hatched, and both the cock and hen watch them closely, taking them

into those parts of the moor where their food is near the ground. The young birds feed on the shoots of the ling and fine leaves of the heather, together with the leaves and berries of the fine-leaved wortle. Both old and young will take grain or seeds of any of the grass tribe when they meet with them, in addition to the food which I have already alluded to, and which forms their regular diet. The *general characters* of the red grouse are as follows:—Bill very short, and clothed at the base with feathers; upper mandible convex, and bent down at the point; eyebrows naked; wings short, concave, with the third and fourth feathers the longest; tail square at the end in most cases; legs and feet completely feathered; hind toe very short, and barely touching the ground with the tip of the nail. There is a great difference in the size and also in the plumage of grouse, according to the district in which they are found. All are more or less marked with brown, white, and black, but the shades of these, and consequently the predominating colour, will vary from a dark to a light brown. Mr. Yarrell thus minutely describes a male bird in his first year's plumage, killed in December:—Beak black; irides hazel, with a crescentic patch of vermilion-red skin over the eye, fringed at its upper free edges; head and neck reddish brown, more rufous than any other part of the bird; back, wing, and tail coverts chesnut brown, barred transversely and speckled with black; distributed among the plumage are several feathers in which the ground colour is of a bright yellowish brown; all the quill feathers dark umber brown; the secondaries and the tertials edged on the outside, and freckled with lighter brown; the tail of eighteen feathers—the seven on each outside dark umber brown, the four middle feathers chesnut brown, barred with black; on the breast the plumage is darker than on the sides, almost black, and tipped with white; the chesnut-brown feathers on the sides, flanks, belly, vent, and under tail coverts, tipped with white; legs and toes covered with short greyish-white feathers; claws long, bluish-brown colour at the base, nearly white at the end. The old male has many of the body-feathers tipped with yellow, and the red colour is of a lighter tint.

Sometimes grouse are met with of a cream colour, and of

all intermediate shades. The whole length of the cock is about sixteen inches on the average, and his weight about twenty-four ounces and a half. The hen is smaller, averaging in weight about twenty-three ounces. The patch of naked skin over the eye is also smaller. The red and brown tints are likewise lighter in colour, and the plumage is more variegated. In the summer, all the feathers of the upper part of the head and neck are a yellowish chestnut with a few black spots; those of the lower neck, breast, back, wing, and tail coverts, are brown, transversely barred with black and tipped with yellow. Red grouse have been bred in aviaries, and in this way they *may* be brought up in considerable numbers, but they are difficult birds to rear, and the plan is not a profitable one. Although usually pairing, there is reliable evidence that a single cock has been seen to mate with two hens in several instances.

The PTARMIGAN (*Lagopus albus*) is the smallest of the grouse found in this country, and is now confined to the tops of the high ranges of hills in the northern parts of Scotland and also in the Hebrides and Orkneys. In Ireland and Wales it is not known. On the Continent of Europe it is met with on most of the elevated mountain ranges, and its range extends to Greenland and the most northerly parts of North America. In Norway another species (*Lagopus subalpinus*) is often confounded with it; but this is a larger bird, and inhabits a higher range of the mountains. The male ptarmigan of Scotland has the following changes of plumage: In winter, the beak, lore, and a small patch behind the eye, are black; irides yellowish brown; over the eye a naked red skin; almost all the plumage pure white; shafts of the primary quill feathers black; the four upper tail feathers white, the fourteen other tail feathers black tipped with white; legs and toes white; the claws black. The male in May and November has the throat white; head and neck mottled with blackish and speckled-grey feathers, a few others with narrow bars of black and ochrous yellow; the white feathers assuming the greyish black by a change of the colour, as particularly observed in progress in a male bird in March, when the few feathers which were then growing were all greyish black; the breast, back, and upper tail feathers

nearly uniform speckled grey; the fourteen under tail feathers black; the wings, the under surface of the body, and the legs white. The length of a male is fifteen inches and a quarter; the female is smaller than the male, and is pure white in winter, like the male already described, except that she has no short black feather before or behind the eye. By the end of April, the female has assumed almost as much mixture of feather (barred black and ochrous yellow with white tips) as the male bird has of those which are grey. According to Yarrell, a female bird from Scotland bought in the London market, during the second week in May, 1839, was much further advanced, having the whole of the head, neck, back, rump, upper tail coverts, upper part of the breast and sides, covered with feathers of greyish black and yellow in bars, many of them still retaining the white line (see "Yarrell's British Birds," vol. ii. p. 367.) In September the upper surface has become of a mottled grey, and the under patches have some grey feathers among the yellow ones; as the autumn advances, the yellow feathers are shed, and then the grey ones, leaving the plumage of a pure white. The length of the female averages fourteen inches and a half. Like the red grouse, the ptarmigan pairs early in spring, and the hen lays eight to ten eggs, generally on the bare ground, among large stones. The eggs are yellowish white, sparingly blotched and spotted with dark brown, length one inch and two-thirds, breadth one inch and a sixth. The ptarmigan feeds on the berries, seeds, and young shoots of alpine plants. The brood or family keep together till the depth of winter, when they break up. They have never been reared in confinement; but in a wild state they are not so difficult to approach as the red grouse, sometimes appearing to be actually so dull and stupid, that, as Mr. Colquhoun asserts, by throwing a stone at the pack they may frequently be made to crouch on the ground till they are walked up. According to Mr. Macgillivray, "When squatted, they utter no sound, their object being to conceal themselves; and if you discover the one from which the cry has proceeded, you generally find him on the top of a stone, ready to spring off the moment you show any sign of hostility. If you throw a stone at him, he rises, utters his call, and is immediately joined by all the

individuals around, which, to your surprise, if it be your first rencontre, you see spring up one by one from the bare ground. They generally fly off in a loose body, with a direct and moderately rapid flight, resembling, but lighter than, that of the red grouse, and settle on a distant part of the mountain, or betake themselves to one of the neighbouring summits, perhaps more than a mile distant. In winter several families of ptarmigan associate, forming a flock, and fifty in number have been seen together."

THE MOORS.

The capercaillie and the ptarmigan are both so rare that it is scarcely necessary to allude to the ground upon which they are found, beyond the slight notice which has been given of each in the several descriptions of these birds. But red grouse and black game constitute the staple of the grouse shooter's amusement, and the nature of the ground which they frequent should be well known before the young sportsman commits himself to this kind of work. With the exception of deerstalking, there is no species of British sport which so thoroughly tasks the energies of man as grouse shooting, if it is pursued with energy and spirit; for though it may be possible for the lover of nature to saunter away a morning among the beautiful scenery which is generally displayed to his gaze, without any great fatigue, yet if the bag is to be filled, he must keep up a steady, unflagging walk over hill and dale, and generally over heather or rough ground of some kind, which will make him lift his legs higher than is convenient to muscles uneducated to the task. Now and then, also, he must expect to sink ankle deep, or a little deeper perhaps, in a bog, which species of ground is to be found on almost every moor. Indeed, it is from the peaty and naturally poor nature of the soil that those extensive districts known as "moors" are not cultivated in the ordinary way; grasses of a very poor description, heather, and ling being their chief products, as far as the vegetable kingdom is concerned. Independently of game, sheep and cattle are the only stock which are fed on these moors, and the proportion of these per acre is very small as compared even

with the downs of England. Of late years, by burning a large tract of heather every year, which greatly encourages the growth of grass for a time, the amount of stock which the moors will carry has been enormously increased; but this gain to the sheep-farmer is a loss to the sportsman, inasmuch as that grouse require a high growth of heather for protection, and plenty of young shoots for food, both of which wants are interfered with by burning; in addition to which, in proportion to the numbers of the sheep, is the disturbance to the grouse increased, not merely from these animals themselves, but from the necessary supervision by the shepherds and their dogs. All these circumstances combined, together with the grouse disease, which seems to increase in proportion to the inroads of the sheep, appear to be gradually interfering with the moors as nurseries for game; but more serious than all is the system of poaching which is carried on, both in the breeding season and also in the autumn. The nests of these birds are now systematically robbed of their eggs, which are sold, partly to stock other moors, and partly to satisfy the appetites of gourmands, who care nothing how they spoil sport so long as their palates are gratified. This subject, however, will be more satisfactorily discussed under Book VI., in which the various devices of poachers will be met with corresponding remedies as far as they are known; and the nature of the grouse disease will also be discussed.

From these remarks it will be obvious that the fatigue of *walking* the moors is not to be lightly encountered except by those in possession of health and strength. The invalid, or naturally weakly sportsman, should make up his mind either to put up with an inferior bag, or else he must take to a shooting pony, which will enable him to get over nearly as much ground as his more active friends. Furnished with a well-broken animal of this class he may generally keep within reach of his dogs; but it will often happen, nevertheless, that he will be obliged to make slight detours, where an active man on foot could readily go straight to his point. The air of the moors is generally of a very bracing character, and many men can take severe exercise on them who would be incapable of going through a walk of half-a-dozen miles in length after partridges in the south. On some moors the

accommodation is pretty good, but generally speaking the sportsman must be content to rough it; and unless he takes his cook with him, he will find the fare of a very primitive character. Mountain mutton, salmon, and grouse are delicacies of the most delicious kind, but *toujours perdrix* tires any stomach, and a month of this fare, with no other addition, will generally satisfy the most ardent admirer of such viands, especially if the exercise has been confined to the amount which a shooting pony gives; while, on the contrary, a hard day's walking will make even oat-cakes taste well to the Englishman's palate, and that is no slight test of its good effects.

BEST DOGS FOR GROUSE SHOOTING.

This is a subject which has been discussed with great animation ever since the sport became general, and it is one which is by no means settled to this day. The preponderance of evidence is, however, in favour of the setter, though latterly, I think, the pointer has been gaining ground, especially with those who use their dogs for partridges as well. There can be no doubt that each has several good qualities more fully developed than the other, but to counterbalance these are nearly as many bad ones, so that it is only by striking a balance that any opinion can be arrived at; and as most people judge from the facts which they themselves have witnessed, so each person who forms an opinion will be a setter or pointer fancier according as he happens to have had a good one, or, perhaps a superior brace, of either of these dogs. That extraordinary animals of each kind are occasionally met with, no one will deny; and it would generally be a toss up in any company whether there would be more votes in favour of the experience of the majority supporting the claims of the pointer or the setter; but still, perhaps, it may be assumed that a slight preponderance as regards grouse (*per se*) would be found to exist in favour of the latter. The quantity of ground required to be beaten, the extent of the range, the rough nature of the surface, which quickly strips the feet and legs of the delicate pointer, all demand a dog with great power of endurance, considerable speed and range, and legs and feet well clothed with hair. These are all found

fully developed in the setter, and his want of steadiness, as compared with that of the pointer, is soon cured by the work which he has to perform. So, also, although the season for grouse is three weeks earlier than that for partridges, yet the air is so cool on the moors that the dogs do not suffer nearly so much in August from heat as they do in September on the low grounds of Norfolk and Suffolk frequented by the partridge shooter. Water is also generally in abundance; and hence it is found by experience that a team of good setters will, in grouse, beat an equally good lot of pointers, each being composed of first-rate animals of their kind. Very many excellent dogs of the latter variety are met with occasionally, but as a class they are deficient in courage, and, partly, from being bred for partridge shooting, their range is too limited, and their feet and legs soon become sore for want of the natural covering of hair peculiar to the setter. A cross between the two, called "the dropper," is sometimes found to produce an excellent dog, combining the good qualities of each; but to breed one good one in a dozen puppies is quite the highest average, the other eleven being generally defective in some respects. Russian setters have also been tried in the north, but their coats are too long and woolly to work well in heather, and they have never been approved of there, nor are they now very common anywhere in this country. My advice, therefore, to those who want dogs for grouse shooting only, is to have a team of setters, taking care that the breed is a good one, and that they are well broken, and worked up to the day before the 12th of August, so as to insure their steadiness. If, however, the same dogs are also to be used in partridge shooting, it is quite a doubtful question; but I should be inclined to prefer a hardy and high-couraged breed of pointers, as they are more readily made to accommodate the nature and extent of their range than are setters, who are naturally more self-willed and headstrong. Indeed, as a rule, it may be said that the setter is never broken; for however steady he may be, if he is allowed to rest for a week, his courage is so high that he will show a little wildness, while a thoroughly broken pointer is to be depended on from season to season, unless he is spoilt by bad shooting or bad management of some kind.

THE GUN FOR GROUSE SHOOTING.

In the very early part of the season long shots do not often occur, but afterwards they are the rule, and unless a gun hits hard it is comparatively useless. Most men, therefore, select a particularly hard-shooting gun for this kind of sport, and if their strength is equal to the attendant weight, they like a large bore, No. 12 being that generally chosen. Whether it (or *she* as the gunmakers say) should be a breech loader or a muzzle loader must depend upon the comparative shooting of each, which we shall discuss in the fourth book. It must be remarked that scattered grouse are often met with, and consequently quick loading is an essential to a good bag; but unless the gun is also a strong hitter, the good quality is more than counterbalanced by this defect. The question requires a long experience to decide it; but I am persuaded, from the evidence of others who have tried both, and from my own experiments, that on the whole the breech loader will be found to be the more serviceable tool. It would occupy too much space to go into my reasons for this conclusion here, but they will be found at length in the fourth book. The shot most useful in the month of August is No. 6; afterwards, some people employ No. 5, or load one barrel with No. 6 and the other with No. 5.

DRESS AND ACCESSORIES.

In choosing the dress for grouse, two things are especially to be considered:—First, what colour will least attract the attention of the grouse? and, secondly, what material will be most comfortable to the wearer? It is found by experience that a mixed pattern (such as the plainer Scotch plaids), will harmonize with the surrounding scenery, and on that account is found to suit well. The heather pattern is also especially recommended, being partly made up of the exact colour of the blossom of that plant. Such are the best colours, and this being settled, the only other requisite is the texture of which the dress should be composed. I have already remarked that the temperature of the moors is much colder than that of more southerly and less exposed regions,

while from their elevated range they seem to attract the clouds, and hence rain and mist are constantly to be expected. Now, every one of experience knows that woollen materials are the most proper for such changes from dry to wet, and from a warm to a cold temperature, and so woollen plaids and friezes are the only proper articles for the upper garments of the grouse shooter. In fine weather a thin fabric, but still of wool, may be adopted; but when the air is cold or there is a chance of rain or mist, a stouter kind should be put on, and the chance of a hot sun risked in preference to attacks of rheumatism, which are sure when the skin is not sufficiently protected. Flannel should also be invariably worn next the skin, without which safeguard even the most robust will occasionally contract a severe cold or rheumatic attack. It is true that the lower moors are sometimes extremely hot in August, and in such cases a linen jacket, may be worn over thin flannel; but few sportsmen go through the day without a rest in the middle of it for luncheon, and if they have nothing on but a thin linen jacket, a chill is almost sure to result. The fashion of the day will of course be consulted by those who follow the dictates of this *exigéant* goddess; but let what will be generally worn, the clothing for grouse shooting should be loose, so as to give the limbs full liberty of action. For the head, a cap or light felt hat is the best protection; the former being of some woollen material rendered waterproof by the preparation which is now used for that purpose, without impeding the evaporation from the skin. As to the feet, they should be invested with lamb's-wool socks, and in case they are inclined to blister, these should be well rubbed, both inside and out, with slightly damped soap. Of boots or shoes every one should wear that particular kind to which his feet are accustomed; for a change from one to another causes pressure in fresh places, and is often very distressing. Some wear laced ankle boots, others "Balmorals," and others, again, Wellingtons made on purpose, that is, with nailed soles; but in any case the soles should be stout, and rendered rough by means of nails, while the fit should be insured by previously wearing them. To render them waterproof there are numberless receipts, which must

vary according to the nature of the leather used. Some men now wear enamelled leather, which for a time is in itself impervious to water, and this must be dressed, as the surface cracks, with a polish sold on purpose, composed partly of india rubber. Calf skin, on the contrary, will not take this kind of varnish, and it should be kept well saturated with a composition made of boiled linseed oil one pint, bees' wax, resin, of each four ounces, melted together and stirred till cold.

The accessories will depend upon the nature of the gun which is used, that is, whether a breech loader or a muzzle loader. If the former, nothing is required but the loaded cartridges, which may be carried in a case, or loose in the pocket, and in addition, the little instrument which is sometimes required to extract cartridge cases after firing. For the latter, you must take a powder flask, shot pouch, cap holder, wadding, and nipple-wrench. In addition to these, a dog whistle is required, and if you work your own dogs, a whip should never be forgotten. The "gillie" will also carry the essentials for the game which you are to kill, and any spare ammunition, as well as a gun cover, and if you are not regardless of weather, a waterproof coat for yourself.

MANAGEMENT OF THE BEAT.

This exciting sport is conducted very differently in the early part of the season, and towards the latter end of it. In the former, unless the birds are unusually wild, almost any method of beating, so long as the dogs can work up wind, will enable you to obtain a fair proportion of shots; but towards the end of September, or, indeed, sometimes much earlier, some precautions will be necessary to secure good sport. A good marker is almost as essential to grouse shooting as a good dog, and among equally good shots, he who is best provided in this particular will show by far the best bag at the end of the season. In grouse shooting, it is a bad plan to leave any ground unbeaten in the hope of reaching better; these birds are most capricious in their fancies, and they will be found on one day where not a bird, perhaps, was to be seen on the previous one. It will, however, always

be desirable to beat towards the centre of the moor, so as to avoid driving the game off it, and for this purpose the experienced hand begins from the leeward side, so as to beat up wind, and towards the middle of his moor. Having commenced at eight or nine o'clock, by one or two the whole of that side will have been beaten ; for when the grouse are as numerous as they ought to be early in the season, it will scarcely answer to follow up each pack, as must be done later on in the year. At the same time the centre of the moor will have been filled with the disturbed coveys, many of which are more or less scattered. Then, with a careful brace of dogs, he must proceed to beat this ground systematically, which will probably occupy the shooter till the end of the day ; but on no account should he work on farther, towards the windward side of his moor, for fear of sending his birds off it and into another. Beyond these simple directions, experience must be the guide in conducting the beat, and on hilly ground no one but a person accustomed to that particular locality can give useful advice. Generally speaking, grouse dislike leaving their own hill, and will fly round and round its sides if they are followed up, just putting the brow between them and their persecutor. Later on in the season they take long flights, either from hill to hill, or from the high ground to the low, but in August they do not often go so far in their flight. Of course, bare ground without covert of any kind will very rarely hold game, and when this occurs it may be left untried, as may freshly burnt heather, which is never the haunt of grouse by any chance. On the other hand, when he falls in with patches of heather of all ages, interspersed with green moss and bogs, with here and there a small pool of water, the sportsman may be in constant expectation of a point. In hot weather, during the middle of the day, grouse lie close, and it requires a good nose in the dog which finds them. In wet weather no sport can be obtained, the birds being in sheltered situations, where they are with difficulty found. So also in very windy weather they are so wild that they rarely suffer an approach, but get up out of shot, and are off to the next hill side.

Such is the plan to be pursued early in the season, but later

on, a very different one must be adopted. It is very seldom after the first month of grouse shooting that a shot can be obtained until the covey or pack is broken, and hence it must be marked and followed up with the greatest care to avoid losing sight of it. At any inoderate range—say within fifty or sixty yards—the leading bird should be fired at, as, if it drops, the pack are almost sure to disperse. In such a case, the “gillie” must carefully mark down as many as he can, and these should at once be followed up, even if the flight is a long one, beating the ground towards them, so as to avoid loss of time. At this season grouse almost always run before the dog, and therefore when he points, unless the shooter is in a line behind him, he should make for a spot considerably in front of the dog, with both barrels of his gun cocked, so as to get a quick “right and left.” In this way single birds will be picked up, and sometimes the whole covey will be bagged one after another. Towards evening, grouse lie better, and the scent also improves, so that good sport is often met with at this time after a disappointing day.

The number of dogs required by each party of shooters will vary a good deal according to the nature of the dogs themselves, and to that of their masters, as well as the ground. On the average, however, it is of little use to go to the moors with less than three brace, as there are few dogs which will work longer than half a day, and generally one will be lame or sick. Where two or three guns beat in company, three dogs will generally be required; but for one gun a brace is sufficient, if they are good rangers; sometimes a third dog working close to the sportsman is an advantage, but he is very apt to disturb the equanimity of the ranging dogs, who become jealous of him, and think their master is paying attention to another behind them. Six brace of *average* dogs will not be at all too large a kennel to take to the north by a party who intend to keep at their work day after day, especially if they consist of pointers, which will not do much more than half what will be accomplished by first-rate setters.

Black-game shooting early in the season is a very easy affair, the hen and the young birds being then found in the high grass or rushes near water, the latter lying very close,

and when put up, flying slowly and heavily. The old cocks are not with the young broods, being met with either singly or in twos, threes, or fours together, according to the number of black game on the moor. These last fly strong and fast, and are seldom to be found a second time, if not bagged at once, as their flight will generally be far out of bounds. Later in the season, black game are very wild, and are seldom to be killed on the open moors, small coverts near cultivated ground, where they feed on the corn, being their most likely haunts, especially if there are juniper trees in them. In order to get shots at this time, these plantations must be beaten towards the gun, who should be thirty or forty yards in advance, and on the upper side. The beater should keep outside and below, and sending in a couple of steady spaniels, he should make a slight noise by tapping the bushes, which will drive the game out on the shooter's side.

Both red grouse and black game may be driven as well as stalked. In the former mode the sportsman conceals himself behind a wall, a rock, or other similar covert by or near which his game may be expected to fly; then sending the men round, they begin to beat the ground towards him, the more experienced being very skilful in sending them exactly in the direction of the shooter. This sport, however, requires a quick eye and hand as well as great coolness, for these birds fly with great velocity when fairly on the wing. Some advantage may be gained by the shooter rising suddenly just as the grouse is nearly over head, the abrupt view of his person causing the latter to ascend, and thus stopping the rapidity of flight, an easier shot is obtained. In *stalking*, the grouse or black game are first discovered with the glass, and then advantage is taken of every inequality of ground to approach within shot, avoiding going down wind with the greatest care.

Retrieving grouse may be effected either by means of the pointers or setters which are employed to find them, or by special retrievers set apart and broken for the purpose. The former plan is strongly advocated by Colonel Hutchinson, and is adopted by a great many grouse shooters; but I am strongly of opinion that in all kinds of shooting where pointers

and setters are employed, these dogs should not be allowed to retrieve. Nothing is so fertile a source of jealousy among them as the seeing one of their own body sent for the purpose of "seeking dead," while the rest are expected to be steady "down charge." The same bad effect is not produced when they see a special retriever employed; for even if they are jealous of him, it does not make them unsteady afterwards, because they are not working together with him in their own peculiar department. All the setters cannot retrieve at one time, but one must be selected to do the work and hence the others consider themselves ill-used, and will either refuse to back the favoured one, or will work in a way to lead to the loss of sport. Great practice, moreover, is essential to success in retrieving, and if this is divided amongst three or four instead of being concentrated in one dog, a loss is sustained which will tell greatly against the "bag." For these reasons, therefore, I should strongly advise that every team of pointers or setters should be strengthened by the addition of a thoroughly well-broken retriever, which may be of any of the following kinds. The LAND RETRIEVER proper is no doubt the small or St. John's Newfoundland, more or less crossed with the setter. This produces the handsome animal shown in the engraving in the second book, and he will be found to do all that is required. He may be used for water as well as land, but he is not capable of so much work as the water spaniel. From his large size also he is sometimes unable to follow the pheasant through the runs of a covert, and in this case he is beaten by the smaller dogs broken to retrieve, such as the cross of the terrier and beagle exhibited in the background. The cross of the rough terrier and pointer, advocated by Mr. Colquhoun, is a very good one, and for general purposes is admirable. A dog of this sort is represented in the coloured engraving in the second book, being intermediate in size between the other two. A little dog, between the beagle or spaniel and the terrier, is sometimes employed for retrieving partridges and even pheasants, but this variety is too small for carrying hares. One of these also is represented in the same illustration.

PARTRIDGE SHOOTING.

As in the case of grouse shooting, I shall here first allude to the various birds likely to be met with on partridge manors, then the nature of that ground, the best dogs for the purpose of finding these birds, and the gun most suitable for the sport.

BIRDS FOUND ON OUR SOUTHERN MANORS.

The *Common Partridge* and the *French or Red-legged Partridge* are the only two varieties met with in this country, the latter being now very rare. Some years ago it was introduced, and bred in considerable numbers in Norfolk and Suffolk; but it was found to give such bad sport, that it has been almost exterminated.

The COMMON PARTRIDGE (*Perdix cineria*) is so well-known as to make it unnecessary to describe its appearance, and I shall therefore do little more than allude to its habits. The length of the cock bird averages twelve inches and a half, the female being generally a little smaller. The latter is also distinguished by having the chesnut-coloured patch round the beak of a lighter shade and smaller in size than that of the male, so that it does not extend backwards beyond the perpendicular of the eyes. The lower breast also is white, and does not put on the dark chesnut patch till the second or sometimes the third year. The bars on the flanks are likewise broader than on the male. Young birds before their first moult may be known by the absence of the red mark behind the eye and by the uniformly brownish-yellow shade of the ground-colour of their plumage, the bars being of a dark brown. Partridges pair in February, and begin to lay in April. The nest is made on the ground with a few leaves and bents, and the spot selected is generally either in mowing grass or clover, or in corn. The hen lays from twelve to twenty eggs, which are of an olive-brown colour, one inch and four lines long by one inch in breadth. From thirty to thirty-six eggs have been found in one nest; but in such instances, two hens must have laid in it, as not unfrequently happens. The partridge sits twenty-one days, and the general hatching time in the south of England is in the latter

part of June, but occasionally the young birds come out much earlier in the year. The young birds leave the nest directly, but they are carefully watched over by both the old birds till they are strong on the wing and able to take care of themselves. The stratagems of the old cock and hen to draw attention from their young ones are most marvellously interesting to the lover of nature, and sometimes lead to the belief that their reasoning power is of a high order. These manifestations, however, are considered to be purely instinctive, but they certainly assume at times the appearance of a higher order of mental power. Both the cock and hen will perform the most curious gyrations, turning and twisting about with apparently a broken wing, just as if they were in the agonies of death. This of course induces any inexperienced person to approach with the view either of giving assistance or of making a capture, but a near proximity speedily cures the attack, and the old hypocrite moves off just beyond the reach of the witness of his or her antics. In the meantime, the other partner has been leading off the young brood to a place of safety, where they are speedily joined by the one which has been playing off the tricks that have just been described. Two partridges, when together, are called "a pair," and when, after the breeding season is over, they are unaccompanied by young, they are denominated "a barren pair," which may be either caused by having lost their nest, or from both being of the same sex, as will sometimes happen when there is a preponderance of either. The old and young together constitute "a covey." These during the day are seldom seen on the wing, unless they are disturbed, but when not on the feed, they frequent the hedge sides of grass fields or the banks of brooks, or they "bather" in the dusty banks of hedgerows, in order to get rid of the parasitical insects which infest their skins. In the morning and afternoon they are on the feed, which is either in the standing corn or in the stubble after it is cut. At dusk they "call" to one another, and having assembled, they move off to their resting-place for the night, which is generally on seeds or grass, where they "jug" or nestle close together on the ground, with their heads directed outwards. They feed on corn and other seeds, varying their diet with a

small proportion of insects. Early in the season partridges fly a very short distance, generally dropping in the next field when they are disturbed; but towards November they become very wild, and often fly for a mile or more, and at a great pace. On hilly ground they are particularly inclined to these long flights. The scent of the partridge is not so strong as that of the grouse, nor is the ground which they frequent so favourable to finding them as that on the moors; hence partridge shooting requires dogs with a better nose and more careful hunting than that of the grouse, and for this reason the pointer is preferred to the setter in the south.

The RED-LEGGED or FRENCH PARTRIDGE (*Cacabis rufa*), sometimes also called the GUERNSEY PARTRIDGE, has long been an occasional visitant to the manors on the eastern coast; but in the early part of the nineteenth century considerable numbers were imported and turned out in Suffolk and Norfolk. Being more hardy than the common partridge, it was hoped that a larger stock could be obtained, and this opinion has been verified by the result; but they are so injurious to sport by their habit of running before the dogs, and also so dry and insipid when put on the table, that they are now pursued to extermination. Still in some districts a few birds remain, but it is probable that in the course of ten years the breed will be almost unknown again. The old cock has the beak red, from which a black streak passes to the eye; in front of the throat is a black gorget, ending in streaks which descend on the breast; iris reddish orange; eyelids of a rich vermilion; top of the head with a line of white both before and behind the eye; all the upper parts of the body uniformly brown; wing feathers greyish black, with a brown margin to each feather; tail chesnut; breast pencil grey; under parts fawn colour; sides and thighs covered with feathers barred transversely with black and fawn-coloured marks on a pearl-grey ground, approaching to a pure white in some parts; legs and toes vermilion; a knob in place of a spur; claws brown. The length is about thirteen inches and a half in the male, the female being somewhat smaller. In other respects there is not much difference between the sexes, except that the plumage of the hen is not

so bright as that of the cock, and she has no knob in place of a spur. The flesh is white, dry, and tasteless, which is also another reason for the dislike which is taken to this bird by game preservers. They are stronger on the wing than the common partridge, and if they can be approached near enough when in the air, they afford good sport; but they run so far in front of the dogs before they rise, that a shot can seldom be obtained. Sometimes they perch on trees or hedge-rows, but this is not by any means a common habit with them. If they are in very great abundance, close-ranging spaniels drive them up better than pointers, which latter dogs allow them to get out of shot. They make their nest in the same way and in the same places as the common partridge, and lay from fifteen to eighteen eggs, which are of a reddish yellow white, spotted and speckled with reddish brown; in length one inch and a half by one and a quarter in breadth. The young birds leave the nest directly, and are reared and fed in the same way as the common partridge.

The QUAIL (*Coturnix communis*) is recognised by the following characters:—Beak strong, shorter than the head, and with the upper mandible curved; nostrils basal, lateral, half closed by an arched membrane; feet with four toes, the anterior ones connected by a membrane as far as the first joint; tail short, rounded, recumbent, almost hid by the tail coverts. The colour is as follows in the adult male:—Beak brownish grey; iris hazel; top of the head dark brown, with a pale wood-brown streak of the same colour over the crown of the head to the nape of the neck; feathers of the upper parts brown, with lighter-coloured shafts, and each having a longitudinal streak of wood brown; wing primaries dusky brown, mottled with light brown; chin and throat white, bounded by two half-circular dark-brown bands descending from the ear coverts, and with a black patch at the bottom in front; breast pale chesnut brown, with the shafts of the feathers straw coloured, all the under parts yellowish white; flanks streaked with pale chesnut; legs, toes, and claws pale brown. The length seven inches. The female does not differ in size, but has no dark, half-circular marks down the sides of her neck, nor the black patch in front; and the

feathers on her breast are strongly marked with a small dark spot on each side of the light straw-coloured shaft. The young birds resemble the female, the black patch on the front of the neck not being assumed by the cocks till their second year. Quails are polygamous in their habits; the hen makes her nest on the ground, with the aid of a few bits of grass or straw; she lays from seven to twelve eggs, which are of a dull yellowish white blotched with umber brown, in length one inch and one line, and eleven lines in breadth. The period of incubation is about three weeks, the young birds, like those of the partridge, at once leaving the nest and feeding on insects, seeds, and green leaves. They are found in September in "beviess" (as the broods are called) on the stubbles, and many are killed on the eastern coast by partridge shooters. The quail is generally only a summer visitant to this country, but occasionally exceptions to the rule occur, and individuals are met with during the winter. Africa is the country where they chiefly spend this season, crossing the Mediterranean in countless thousands in April and March, and a few arriving in this country in May and leaving in October. Great quantities are imported alive from France, and are fed by the London poulterers on hempseed till they become fat. The flesh is considered a great delicacy, and coming as it does in the height of the London season, it is much valued. They fly quickly, and generally straight and low, but it is difficult to make them rise a second time after being once flushed.

The LANDRAIL (*Oryzometra crex*) is also, like the quail, a summer visitant, appearing in England about April or May, and leaving us in October or early in November. The generic characters are as follows:—Bill shorter than the head, thick at the base, subcultrated and compressed; lateral furrow of the upper mandible broad, and extending more than half its length; angle of the under mandible bending upwards, both being of an equal length; nostrils concave, lateral, linear, ovoid, pierced in a membrane occupying the furrow in the middle of the bill; wings armed with a spine, and having the second and third quill feather the longest; legs strong, of medium length, with the lower part of the tibiæ naked; feet four-toed; toes long, slender, and

without any lateral membrane, hind toe resting almost wholly on the ground; claws compressed and sharp. Colours as follows:—Beak pale brown; iris hazel; cheeks and ear covert ash grey; all the upper parts of the body, head, and tail, pale yellowish brown, each feather having a streak of very dark brown; wings and wing coverts rich reddish chesnut; quills reddish brown; under parts pale buff, the feathers of the sides and flanks being transversely barred with darker reddish brown; legs, toes, and claws pale yellowish brown; whole length rather less than ten inches. The females are smaller than the males, and have the ash grey on the sides of their heads less distinct and pure, and the chesnut colour on the wings mixed with darker reddish brown. The young birds resemble the females. The landrail frequents the long grass of marshy meadows, osier beds, reeds, vetches, rye, and rye grass, as well as fields of young corn. Its presence may always be known in the spring time by its harsh, creaking note, which has given it the name of corn-crake. This call-note, which is used by the male only to attract the attention of the female, is easily imitated by drawing briskly a thin piece of bone or horn over a notched piece of metal, which is used for the purpose of decoying these birds. The note ceases when incubation commences, and in the shooting season this call is of no use. Landrails feed on worms, slugs, and other insects, together with green vegetable matter, and in the autumn on seeds. The nest is made on the ground, and is composed of dry fibres of plants, a field of grass or corn being generally selected. Here, about June or early in July, the hen lays from seven to ten eggs, which are of a pale reddish white, speckled with ash grey and pale red brown; in length one inch and a half, by one inch and a line in breadth. The young birds are covered with black down from the first, and leave the nest as soon as they are hatched. In September, landrails are constantly found by the patient shooter either on the stubbles or in seed clover. It is somewhat difficult to make them rise, and they will often run before the dog for a long distance. When on the wing the flight is slow and very soft, and resembling that of the bat in all but velocity, and affording a very easy shot; but the bird is very difficult to put up a second time if missed

on the first occasion. The flesh is considered extremely delicate, but the body being small, weighing only six ounces, there is not much of it; occasionally a landrail is met with of seven or eight ounces weight. This bird is met with in Scotland, but chiefly in the low lands near the rivers, and consequently it does not often come in the way of the grouse shooter.

The SPOTTED CRAKE and LITTLE CRAKE are also occasionally seen by the partridge shooter, but they are so rare as hardly to require a minute description.

The GREAT PLOVER, NORFOLK PLOVER, or STONE CURLEW (*Eidicnemus crepitans*) is a summer visitant only, arriving in April and leaving in September or October. It, like all birds that migrate to us from the south, is more common on the south-eastern coast than elsewhere, and is so frequently found in Norfolk, that it has derived one of its familiar names from that county. It is also met with in Suffolk, Cambridgeshire, Sussex, Essex, Kent, and Hampshire; but not so often as in the first-named county, whose sandy plains are exactly suited to its habits. Its generic characters may be thus summed up:—Beak stout, strong, and straight, a little depressed at the base; ridge of the upper mandible elevated; under mandible with an angle at the point of junction; nostrils placed in the middle of the beak, extending as far forward as the horny portion, open in front; legs long and slender, with three toes only, united by a membrane as far as the second joint; wings of moderate length, second quill feather the longest. In the adult bird the beak is black at the point with a yellowish-green base; iris golden yellow; top of the head and back of the neck pale wood brown, each feather having a streak of black in the centre; a light-coloured streak under the eye, extending to the ear coverts, having a darker streak of brown under it, which extends beyond the ear coverts; upper parts pale brown, each feather having a dark brownish-black streak; wing primaries almost black, the first and second with a white patch towards the end; the tail feathers with the basal halves mottled with two shades of brown, the next portion white, the ends black; outside tail feathers shorter than those in the middle; chin and throat white; neck and breast pale

brownish white, each feather having a central streak of blackish brown; under parts almost white, with long, narrow, longitudinal streaks of brown; vent and under tail coverts buffy white without streaks; legs and toes yellow; claws black; whole length seventeen inches, the females resembling the males in size and colour. In the young birds also the colours are the same, but the markings less bright and distinct. The great plover is usually found in large unenclosed fields, heaths, and warrens, and is very wary, so as to be difficult of approach. They lay on the ground, the eggs being of a pale clay brown, blotched and spotted with ash blue and dark brown; in length two inches and two lines by one inch and seven lines in breadth. These birds feed on worms, slugs, and insects.

The GOLDEN PLOVER (*Charadrius plumialis*), also called the YELLOW PLOVER and GREEN PLOVER, is often a difficult bird to make out, in consequence of the change of plumage which takes place between the winter and summer. Thus in the *summer* the adult bird has the beak black; iris very dark brown, almost black; on the forehead a band of white; all the upper parts greyish black, the edges of all the feathers having triangular-shaped spots of gamboge yellow; wing primaries black; tail feathers obliquely barred with shades of greyish white and brownish black; the lore, chin, sides of the neck, and all the under parts of the body jet black as far as the vent, the black being bounded on the sides by a band of white under the wing; axillary plume elongated and pure white; under tail coverts white. On the other hand, in *winter* the chin is white; front of neck and breast white, tinged and spotted with dull yellow; the upper parts of the body nearly as in the summer. Thirdly, at the *periods between the two seasons*, these birds may be seen for a time with the under parts of a mixed plumage between the two. The length of the golden plover is eleven inches, both male and female being alike in that respect as well as in plumage at the same season of the year. Young birds during their first autumn have the breast much darker in colour than the same part of the old birds in winter. The hen lays four eggs of a yellowish stone colour, blotched with brownish black, in length two inches by one inch and four lines. These

are deposited in a small depression of the ground lined with a few bents of grass, &c., about the end of May or beginning of June, and chiefly in the northern counties and on the moors and hills of Scotland. The young soon quit the nest, and are carefully watched by both old birds, feeding on worms, slugs, and insects. In autumn they associate in flocks, and go southwards in company, when they are found in heaths, downs, and large open fields, especially near the sea-shore. They are excellently flavoured, and are considered a great delicacy.

The DOTTEREL (*Charadrius morinellus*) appears in the south-eastern counties of England towards the end of April, and is very rarely found in Ireland, still more rarely in the west of England. At the end of ten days or a fortnight, many of them go north to breed on the high grounds of Derbyshire, Yorkshire, Lancashire, the border counties, and Scotland. The adult bird in its summer plumage has the beak nearly black; iris brown; top of the head and neck very dark brown, bounded behind by a band of very pure white; ear coverts, neck, and back ash colour; scapulars, wing coverts, and tertials ash coloured, edged with buff; wing primaries ash grey, the first having a broad white shaft; tail feathers greyish brown, those in the middle tipped with dull white, the three outside feathers with broad ends of pure white; chin and sides of the neck white; the front and sides of the neck below ash grey; from shoulder to shoulder across the breast is a band of white, margined above and below with a dark line; breast rich fawn colour, passing to chesnut; belly black; vent and under tail coverts white, tinged with buff; under wing coverts and axillary plume greyish white; legs and toes greenish yellow; claws black; length nine inches and a half. The flesh of the dotterel is very highly prized, and is in great request among the London poulterers in the spring. They are easily shot or netted, not being at all afraid of the presence of man. They feed on slugs, worms, and insects, and when not breeding, they frequent open fallows, especially those near downs.

The GREY PLOVER (*Squatarola Helvetica*), called likewise the GREY SANDPIPER, resembles the golden plover in many respects, but may be distinguished from that bird by the

presence of a hind toe, which, though small, is distinctly to be seen. It is not so common as the golden plover, but in its habits and in the same remarkable change of plumage, it closely resembles that bird. The *adult* grey plover, in its *summer* plumage, has a black beak; iris very dark brown; forehead and top of the head white, the latter being slightly speckled with black; nape of the neck dusky grey mixed with white; upper parts all black and white, the base of each feather being black, and the end white; wing primaries greyish black; shafts white; tail feathers white, transversely barred with greyish black; under parts black, except the vent and under tail coverts, which are white; legs, toes, and claws black; length nearly twelve inches. In *winter*, the plumage of the upper parts is dusky grey, each feather being edged with dull white; throat, breast, and sides lighter than the back, the feathers being but slightly streaked with grey; belly, vent, and under tail coverts dull white, with some few marks only. Like the golden plover, in the spring and autumn these birds may be met with exhibiting any combination of the above markings, according to the period of the change of feather in which they are taken. The summer plumage is generally completed in May. The eggs are oil green, spotted irregularly with umber brown in various shades, which are most numerous at the broad end.

The PEEWIT or LAPWING (*Vanellus cristatus*) is exceedingly common on almost all open partridge ground, but prefers marshy land, though it is not seldom met with upon gravelly soils, if they are undrained. The name "Peewit" is given to it from the resemblance of the note to that word; and it is called "Lapwing" in consequence of the peculiar slow flapping of its wings in flying. Its eggs are, however, so much sought after for the table, under the name of "plover's eggs," and so many of its haunts are now drained and enclosed, that it is every year becoming more rare. In *summer* the beak is black; iris hazel; upper part of the head black, ending in a tuft of elongated feathers, slightly curving upwards, which are capable of being elevated at pleasure; cheeks and sides of the neck white, speckled with black; an oblique streak of black below the eye; upper parts

dark green, iridescently shaded with purple and copper colour; primaries black, the first three or four being tipped with white; upper tail coverts reddish chesnut; roots of the tail feathers white, ends black; chin, throat, and upper part of the breast rich black; rest of the under parts white, except the under tail coverts, which are fawn coloured; legs and toes dull orange brown; claws black. In *winter*, the chin and throat are white; young birds have the feathers of the upper part of the body edged with buff. Length a little over twelve inches. The nest is made on the ground with the aid of a few bents of grass, and in this the female lays about four eggs; these are not quite two inches long, by one inch and a third in breadth, olive coloured, blotched and spotted all over with blackish brown. The young soon follow the parent birds, who watch them most sedulously, and adopt all kinds of stratagems to lead astray any person suspected of molesting them. They feed on slugs, earth-worms, and insects. In autumn they collect in flocks, and from that time throughout the winter they are excellent for the table, but are too wary to be readily shot. But when partridges are scarce, they afford good sport in stalking them.

There are occasionally other birds suited to the table met with on our partridge grounds; but include all those which may be sought for with a chance of sport.

OUR PARTRIDGE MANORS.

The partridge land of England includes nearly all that cultivated by the plough; but of this a considerable part is not naturally suited to the habits of these birds, who prefer a dry sandy soil, not too level, but undulating enough to keep their nests dry in all weathers. The turnip and barley lands of which Norfolk and Suffolk are almost entirely composed, render these counties the chosen ones of partridge preservers, and here the sport of shooting them is followed with as much zest as grouse shooting in Scotland. In cold clays, where turnips until lately were never met with, and are still somewhat rare, partridges will breed in dry seasons, provided they are not too dry; but here there is generally no lying for them in the shooting season, and they soon

become so wild as to be unapproachable in the day time; the poacher also easily netting them at night. When wheat was reaped, and the stubble fields were left unploughed till November, partridges might be shot in the stubbles as late as the end of October; but these fields are now shorn so close in "bagging" them, or are so soon broken up, that the sport cannot be protracted beyond the middle of September. Some of the finest lands in England for partridge shooting are those parts of our downs which are under the plough; for they are mostly planted with turnips sufficiently to hold birds, while at the same time the plants are not high enough to prevent a dog finding birds in them. In spite of this, however, it is now the fashion to dispense with the use of the pointer, and beaters are employed in partridge preserves as well as in covert, by those who take the lead in fashionable shooting circles. Here the "bag" is considered all important, and if by the aid of beaters, without dogs, two or three extra brace of birds can be brought down, the latter are voted useless, and the modern style of slaughter which is called sport is adopted. Throughout the country many farms are to be met with which have a certain proportion of light land mixed with other which is not suited to barley or turnips, and on such a good head of partridges can almost always be reared. Here, also, the shooting is good, but as the proportion of turnips is not great, and the fields planted with them are consequently not very extensive, they will not hold a very large number of birds for the gun in the middle of the day.

PARTRIDGE DOGS.

The pointer is generally selected as the dog for this kind of shooting, for the reasons which have been alluded to at page 23. As before remarked, however, many sportsmen now dispense with dogs altogether (excepting retrievers); and some of the best shots in England, and possessing the best manors, have not a pointer or setter in their kennels. When the choice falls upon the pointer, there is still an opportunity for selection among the various breeds of this dog which are to be met with, and which show at one extreme the heaviness of the old Spanish dog, and at the other almost

the lightness of the greyhound. Here, as in most other cases, the medium will be found to be the best; but it should combine as much as possible of the large head and broad nose of the old breed with the light wiry form of the modern one. The pointer must not only have a good nose, but he must have sense to know how to use it, and hence the necessity for a large brain. Of these three kinds good examples will be found in the engraving given in the second book.

BEST GUN FOR PARTRIDGE SHOOTING.

The breech loader is in my opinion by far the best gun for this species of shooting, since it hits quite hard enough, and the rapid loading which it allows, is particularly serviceable with scattered birds. Towards the end of the season a strong shooting gun is no doubt a *desideratum*; but if there is any difference in this respect between the two kinds, it is so trifling as to be more than counterbalanced by the greater rapidity in loading. No. 6 is the shot used at all seasons, adopting No. 5 for the second barrel after the end of October.

DRESS AND ACCOUTREMENTS.

A light, and even a linen jacket is almost indispensable in September, when the weather is fine, but on wet and rough days woollen clothing should always be adopted. As there are no briars to be encountered, no leggings are required, but, nevertheless, there is nothing more suited for walking than the old-fashioned leather gaiter or leggings. Fashion, however, settles these minors points, and it is useless, therefore, to descend to particulars, as what will be right in 1859 will be, perhaps, altogether wrong in 1860. For accessories, see page 27, they being similar to those required in grouse shooting.

MANAGEMENT OF THE BEAT.

The first thing to be attended to in partridge shooting is not to begin too early in the day. Whether dogs are used or not—whether the birds are to be sought for on the

stubbles or in the turnips, they will not lie till the dew is off, and, according to the season, the commencement of the day's sport must be delayed till nine or ten o'clock. In every case a good marker is a *sine quâ non*, unless the modern system of driving in to the turnips is adopted, and then it is not required. As, however, everything depends upon the plan adopted, it will be well to consider the two as quite distinct.

In the old-fashioned mode, a brace of steady pointers and one or two markers being provided, the stubbles are entered as soon as the dew is off the ground, taking care to beat "up wind," and in such a direction as to drive the birds towards your own ground, and, if possible, where there is a piece of turnips, seed clover, or potatoes, any of which is likely to hold the birds when they leave the stubble-fields. The pointers should not range very wide, and should beat out all the ground carefully, avoiding the fault, which is so often permitted, of allowing them to go straight into the centre, where birds, it is true, are very apt to be, but in reaching which part many other likely spots are left unbeaten. The sportsman or sportsmen should walk well up to their dogs, but without hurrying them; for there is as much harm done by walking too fast as by lagging too far behind. When a covey is found early in the season, they should be approached steadily and in perfect silence; then, as soon as they rise, let the first bird which shows itself, and which will almost invariably be one of the old ones, be singled out and shot when it gets to the proper distance. If two friends are shooting together, each will single out a bird on either side of the covey, avoiding the "ruck," the shooting into which is un-sportsmanlike and cruel. The centre of the charge is the only part to be relied on for killing with certainty, and as this can only take in one or, at most, two birds, the rest would run the risk of being wounded without being killed. As the covey fly off, the marker, or in his absence the shooter, must keep his eye on them till they alight, and carefully note the exact spot. In doing this, if the flight is a long one and the covey gets out of sight on account of the distance, the eye should be kept well forward on their line, and generally the flutter of the wings, which precedes the settling

on the ground, will be perceived. Now, having noted the exact spot, reload, and retrieve the birds killed; and then, unless the distance is enormous, or the covey is out of your beat, proceed at once to look for them, and in doing so, take care to beat the ground, where you expect to find them, in such a direction as to keep them on your own manor. As they rise, serve them as before, and follow them up as long as possible before proceeding to look for another covey. Of course, if there is time, the second barrel will be used in each case. Unless birds are very plentiful, this is found to be by far the best plan; but where they are thickly preserved, it often happens that in going from one field to another fresh coveys will be found, and these will then naturally be shot at. Should the birds be very wild, send the dogs up the hedge-side and make them beat towards you; by which method shots may often be procured which would otherwise be impracticable. In searching for fresh coveys, the most likely ground will depend upon the time of the day and the season of the year. In the early part of the season birds are on the feed till eleven o'clock, after which, in hot weather, they resort to brook-sides, potatoes, turnips, and similarly shaded spots till about three o'clock, when they return to the feeding ground again, and remain there till dusk, at which hour they may be found "calling," preparatory to their night's "jug." Later in the year they frequent fallows, if undisturbed, in the middle of the day, and are also likely to be met with on dry banks, especially where there is a bare sandy spot for them to dust themselves and bask in the sun. When very wild, so as to rise out of all chance of a shot, it is found that by flying a kite over the ground when they are on the feed, they will lie close, probably mistaking it for a hawk. At these times the great object is to scatter the covey, as single birds always lie comparatively well. Hence it is that the kite is so successful; for when the birds do rise, they fly off in all directions, and may then be picked up in detail, lying like stones.

The modern fashionable mode of partridge shooting is quite a different kind of proceeding to that above described. Here the stubbles are not entered by the sportsmen, who wait till the birds are off their feed before commencing their opera-

tions, and then content themselves with about three, or at most four hours' shooting, which is confined to the turnips. Preparations have been carefully made by the keepers, who, during the two hours prior to eleven, have been beating the stubbles towards the turnips with the aid of spaniels and ponies, and by the hour named, all the birds are collected in the large fields of turnips or other green crop, which are essential to success in this kind of sport. At the hour fixed, the party assemble to the number of four, five, or six, and forming a line, each being about thirty or forty yards from his next neighbour, they walk straight across the field. Between each two shooters there should be one or two beaters, so as to insure a proper driving of the ground, for single birds will lie very closely in turnips. As they rise they are shot at, each by the person to whose share it properly belongs. In order to avoid confusion or dispute as to the killer, imaginary lines are drawn forward and backward midway between each pair of shooters, and all birds killed within the space enclosed by the line on each side of a gun, are supposed to be killed by that gun. This rule is very useful, inasmuch as without it there would be often two or three guns discharged at one bird, with consequent disputes as to the real killer, which are easily settled in this way, and it is unsportsmanlike to shoot at a bird beyond the proper lines of demarcation. As soon as a bird has crossed out of one of these sections into another it may be shot at, and great pleasure is often afforded in "wiping an eye" in this way. When a shot is made, the whole line waits till the gun is reloaded, unless breech loaders are used, when the delay is unnecessary, and in this respect a great advantage accrues to this species of gun. Dogs are not used, except to retrieve, which task is left to the keepers, and the whole sport is confined to the constant shooting at the birds as they rise, forming a wholesale kind of butchery, which appears to be now the sum and substance of the modern idea of what is good sport. Of course, when birds are so thick as they must be to give occupation to four or five guns, it is out of the question to attempt to follow them up; but when the quantity of turnips is not sufficient for the time to be spent in shooting, it is usual to walk them a second time, and this

will generally produce a pretty good second crop of single birds, with an occasional covey.

The retrieving of partridges is conducted exactly in the same way as that of grouse, which is alluded to at page 30.

SNIPE SHOOTING.

In this species of sport, in addition to the various kinds of snipe, several other birds frequenting the fens are met with, especially in Ireland and on the Continent, where snipe shooting is to be found very superior to that of England. But among snipe alone the sportsman will often be puzzled to determine what is the particular variety which his gun has succeeded in bringing down, the common snipe and jack snipe being often mistaken for each other. For the convenience of the sportsmen, therefore, a short description of each will be given, the specific characters being on the authority of Yarrell.

VARIETIES OF SNIPE.

The GREAT or SOLITARY SNIPE (*Gallinago major*), also called the DOUBLE SNIPE, is not uncommon in the fens on our eastern coast, but is almost unknown in Ireland, and on the west of Scotland. When on the wing it can scarcely be distinguished from the common snipe in point of size, but its fan-like tail shows its nature to the experienced eye. These birds are generally met with in the early part of autumn in pairs. They breed in considerable numbers in Norway and Sweden, placing their nest in a tussock of grass, near any bushes on the borders of a marsh. The eggs are four in number, of a yellow olive brown, length one inch and three quarters, breadth one inch two lines. The bird itself is described as follows:—Beak dark brown at the end, pale yellow brown at the base; iris dark brown; a dark brown streak extends from the beak to the eye; above this, and passing over the eye and ear coverts, is a streak of pale brown; top of the head a rich dark brown, with a pale brown stripe down the middle; neck pale brown, the centre of each feather having a darker spot; upper parts brownish

black, each feather having a central line and margin of buff; lesser wing coverts black brown, tipped with pale yellow above, and white below; great coverts black, tipped with white; primaries of a dull greyish black; secondaries black, tipped with white; tertials black, barred and streaked with pale brown; rump dark brown, edged with pale brown; upper tail coverts yellow brown, mottled with dark brown; tail feathers sixteen, of which the four on the outside are nearly all white, the middle eight being of a rich brownish black for the first three-fourths of their length, then comes a patch of chesnut, next a bar of black, and finally they are tipped with white; chin pale yellow brown; breast and sides with half-circular bands of brownish black or pale brown; belly and vent pale brownish white; legs and toes greenish brown; claws black. Length twelve inches; weight seven to nine ounces. Females larger than the males, which are lighter in colour above and below the dark stripe at the base of the beak.

The COMMON SNIPE, SNITE or HEATHER BLEATER (*Gallinago media*) breeds in small numbers in the south of England, and to a large extent in the north, but is chiefly a bird of passage, coming over in November and leaving in March. The third name which is given above arises from the bleating noise made by this bird on the wing, and which is a call of the male to his partner in the breeding season. At this time the cock snipe rises to a great height in the air, leaving the hen on the nest, which is made in a very slight manner, on the ground, and lined with dead grass. The eggs are four, of a pale yellowish or greenish white, the larger end being spotted with brown; length one inch and a half, breadth one inch and one line. The plumage varies according to the season, as follows:—*In winter* the beak is dark brown at the end, pale reddish brown at the base; iris dark brown; a dark-brown streak from the base of the beak to the eye; over this, and extending backwards over the ear coverts, a pale-brown streak; upper part of the head very dark brown, with a pale streak along the centre; back dark brown spotted with pale brown; interscapulars and scapulars dark brown, with broad margins of rich buff, forming four distinct lines along the upper surface of the body; wing

coverts spotted with pale brown on a ground of black, and tipped with white; tertials barred with pale brown on a black ground; primaries and secondaries dull black, the latter tipped with white; upper tail coverts barred alternately with pale brown and dusky black; tail feathers fourteen, the front half dull black, varied on the margins with reddish brown, the posterior half of each feather having an oval spot of pale chesnut, and also tipped with the same colour of a still paler shade; chin brownish white; cheeks pale brown; ear coverts somewhat darker; sides and front of the neck pale brown, spotted with darker brown; under parts white; the sides and flanks being barred with dusky black; under tail coverts pale yellow brown, barred with greyish black; legs and toes greenish brown. *In summer* the old bird has the outer lateral margin of the interscapular and scapular feathers narrow and almost white; all the parts on the back and wings described as of a pale yellow brown in winter, are now of a reddish brown. The plumage of the two sexes is alike. The young birds have the summer plumage. The length of the snipe averages ten inches and a half, the female being the larger of the two; beak two inches and three-quarters long. The weight varies a good deal, according to the condition. The end of the beak, when the bird is alive or recently killed, is smooth, soft, and pulpy, but soon after death it becomes dimpled like the end of a thimble. It is a delicate organ of touch, and assists the bird in detecting its food among the slush in which it bores for it. It feeds on worms, insects, small-shelled molluscs, and seeds.

The JACK SNIPE, JUDCOCK, or GID (*Gallinago minima*) is distinguished by several peculiarities, being more solitary than the common snipe, and very rarely breeding in Great Britain. It comes over in the middle of September, and leaves in the beginning of April, the numbers being not nearly so great as those of the common species, but far beyond those of the solitary kind. Unlike the common snipe, it makes no scream on being put up from the ground, which it is not easy to do, this bird being remarkable for its sluggishness. It feeds on bare boggy ground, but when off the feed, it may be found in sheltered situations among strong rushes

or coarse grass. It is very doubtful whether it now breeds in this country, but formerly the nest was occasionally met with. The beak is dark brown at the point, the base being a pale reddish brown; iris dark brown; from the beak to the eye a dark-brown streak; over this and reaching backwards over the ear coverts, a broad pale-brown streak, with a narrow darker one along the middle line of the posterior half; top of the head a rich dark brown, without any pale streak down the middle; nape of the neck greyish brown, varied with dusky brown; back rich dark brown; interscapulars and scapulars nearly black, tipped with reddish brown, both being edged with rich buff; wing coverts dusky black, edged with pale brown; primaries and secondaries dusky black, the latter ending in a white point; tertials brownish black, spotted and streaked with rich reddish brown; upper tail coverts brown, edged with buff; tail feathers greyish black, twelve in number; cheeks, chin, and neck greyish brown, spotted with darker brown; breast, belly, and vent white; legs and toes dark greenish brown; claws black; length eight inches and a half; of the beak one inch and a half. The females are larger than the males, and the plumage is the same, with the exception that in the former sex it is not so bright in colour. The winter plumage is also nearly like that of summer, the reddish-brown parts of the latter period being more inclined to ash grey in the winter. Young birds are deficient in the green and purple iridescent tints of the adults.

The SUMMER SNIPE, or COMMON SANDPIPER (*Totanus hypoleucos*) is only met with in this country during the summer months, and for that reason is not one of the birds which is likely to fall to the gun in what is called "snipe shooting." Still, as it is commonly known by the name which is here prefixed, and as many people shoot these birds during the summer, it is desirable that my readers should have a detailed description of this and its congener, the green sandpiper. The summer snipe appears in Great Britain during the month of April, and leaves in September; its movements are quick and lively, and its most common haunts are the banks of running streams, where it may be seen close to the water's edge, flirting its tail up and down something after the manner of

a wagtail. When flushed, it utters a note which is said to resemble "wheet, wheet." Its food consists of worms and insects, especially those frequenting the water's edge. Its nest is built in a hole of the bank, where the hen bird lays four eggs, of a reddish-white colour, speckled with brown, in length one inch four lines, breadth one inch. The beak is dark brown towards the point, the base being of a pale yellow brown; iris dusky brown; a brown streak passes from the beak to the eye, over which is a light-coloured streak; upper parts of the head and body greenish brown, each feather having a greenish-black stripe across the centre, and along the line of the shaft; primaries almost black, with a greyish-white patch on the inner circle of all but the first; secondaries tipped with white; the central feathers of the tail the longest; in all twelve in number, and barred with greenish black, the four outer ones on each side being tipped with white; again, the two outer tail feathers on each side have the outer webs white barred with greenish black; chin white; upper part of breast streaked with dusky black on a ground colour of pale ash; under parts of a clear white; legs and toes ash green; claws brown; length seven inches and a half.

The GREEN SANDPIPER (*Totanus ochropos*) is chiefly met with in spring and autumn, a few only breeding in this country. This bird is somewhat larger than the summer snipe, with which it is often confounded, its length being nine inches and a half. Its habits resemble those of the common sandpiper, excepting that it is not so often found in the breeding season, while in the winter it is occasionally met with. Its note is said to sound like "cheet, cheet, cheet." The following is the correct description of this bird:—Beak greenish black; iris hazel; a dusky-brown streak reaching to the eye, over which is a white line; upper parts of head and body dusky green, slightly shaded with dark green; primaries of a uniform dusky black; scapulars and tertials greenish brown, the former having numberless light-coloured small spots on both edges, while the latter have them on the outside margin only; upper tail coverts white; the greater part of the tail feathers white; the outside feather with one small dark spot near the end, the next feather having two of these, the third and fourth with two broad dark

bands, the fifth and sixth with three or four of them ; chin white ; throat and front of the neck white, streaked with dusky lines ; breast and belly white ; sides and axillary plume greyish black with narrow base of white ; legs, toes, and claws greenish black.

Besides the snipes, many other birds are found in the fens, and of these some are excellent for the table, as the RUFF or REEVE, and the KNOT ; but for the description of these comparatively rare birds, my readers are referred to the various works on natural history. Two snipes are termed a couple (not a brace), and several together a wisp.

THE FENS AND MARSHES.

The quantity of this kind of land still left in Great Britain is considerable, but nothing like that which formerly existed. Every year more and more is reclaimed, and much of that which is still called "marsh" is gradually becoming consolidated, and the consequence is that it is not frequented by marsh birds as it used to be. In this kind of land ditches are cut at certain intervals, and the greater portion of it being below the level of the sea, the water is pumped out by steam-power, with the effect of keeping them nearly empty excepting in very rainy seasons. From this wet and boggy character it results that the walking is often such as to lead the shooter into water up to his knees, and hence, unless he is well protected, or weatherproof in constitution, he will suffer in point of health. On the Continent, and in Ireland, extensive marshes are still left undrained, and there excellent snipe shooting may be obtained.

DOGS FOR SNIPE SHOOTING.

The setter is usually selected for this kind of sport, because he will stand the wet and cold incidental to it better than the pointer. If, however, one of these latter dogs can be obtained of a hardy constitution, he will often take to snipe well, and from his steadiness and fine nose he will be found extremely serviceable. A steady dog is all important, but it will generally be found that by using him to snipe he

learns to "potter" in a way which will unfit him for partridge or grouse shooting afterwards. As snipe are beat for down wind, a finer nose than usual is required.

DRESS, ETC.

The essential part of the dress for snipe shooting is that for protecting the feet and legs from the wet, which is inseparable from the sport. Unlike grouse and partridge shooting, a pony cannot be used on this ground, and the delicate-constituted sportsman cannot in any way partake of the amusement without risk. Patent leather boots may be made to be quite waterproof, but they soon wear out; and if the sportsman is anxious about his feet, let him purchase the indian-rubber boots imported from America, which are the only articles entirely to be relied on. When lined with woollen material they are tolerably free from the unpleasant sensation of wet and cold which attends upon confined perspiration; and on this account they are apt to cause the very thing they are intended to prevent, and after strong exercise, if the wearer stands or sits still for a short time he will feel as if he had been walking through a brook. Good calf-skin boots, dressed with boiled linseed oil and bees' wax, are after all the best articles, and with these and leather gaiters, a strong healthy man may bid defiance to cold and rheumatism, so long as he keeps moving and avoids the excessive use of spirituous liquors.

MANAGEMENT IN SHOOTING.

The flight of the snipe is so eccentric that unless the shooter is aware of it he is not likely to be very successful. If this bird is shot at when it has fairly got on the wing, and while it is making those right and left shoots which it practises till it fancies its safety is secured, there is little chance of bringing it "to bag." Hence the plan to be adopted is either to bring it down almost before it is on the wing, which must be done when it gets up at any distance from the shooter, or when it lies pretty close (as is generally the case), to wait patiently till it is thirty or forty yards off, by which time it begins to fly steadily, and then fire. When

first these birds come over in September or October they are very tame, from the effects of their long flight, and they will then "lie like stones;" but in a November frost they are as wild as hawks, and get up with a scream which unsteadies the nerves of the tyro to such an extent as to save many a life. Snipe almost invariably fly against the wind, and in order to avoid their going straight away, it is best to beat for them "down wind." This, it is true, makes it somewhat more difficult for the dog to find them; but by making him cross the ground carefully he will be able to catch their scent nearly as well as on the other plan, and the more so as the scent of the snipe does not travel very far. In mild weather snipe are not to be met with in any numbers on the marshes, but frequent higher ground; while, on the contrary, in frost, they can only obtain their food in situations protected from the frost, and especially in salt marshes, which do not freeze so easily as those out of reach of the sea. The sportsman will, therefore, select his beat accordingly. A retriever is always needful, and he must be broken to water.

THE GUN, SHOT, ETC.

Any ordinary gun is suited to this sport, as snipe, though they take a harder blow than many people imagine, are not so difficult to kill as grouse or partridges. The shot most useful is No. 7, or even No. 8, but late in the season, No. 6 may be put into the second barrel with advantage.

CHAPTER IV.

COVERT SHOOTING.

PHEASANT SHOOTING—COCK SHOOTING—RABBIT SHOOTING.

THE various kinds of covert shooting which are comprehended in the above table of contents, differ from one another most materially, and must be described under separate headings. Battue shooting and cock shooting can scarcely be considered as at all resembling one another; the former being capable of being carried on in a wheel-chair, while the latter requires strength and activity in the highest degree. As before, I shall describe in due order the material for the sport, the nature of our coverts, the covert gun, the dogs used in each variety of covert shooting, the dress most suitable for it, and the various modes of conducting it.

PHEASANT SHOOTING.

The PHEASANT (*Phasianus Colchicus*), together with the HARE and the RABBIT, form the staple of what is commonly known as pheasant shooting whichever mode may be adopted in carrying on this sport. The two latter, however, are only incidentally shot at, and do not form the peculiar objects of the sportsman's search. In addition to the common pheasant we have now a considerable number of the Indian variety introduced into England; these birds being supposed to be more hardy, and affording better sport from their greater rapidity of flight, especially as they rise from the ground. The Indian pheasant is a very neat and elegant bird, its plumage lying closer than the ordinary kind, and making it look smaller than it really is. There is little difference of colour, excepting that the new importations have rings round their necks. They breed freely together. The common pheasant is diffused throughout England, but does not thrive in Scotland, which

is too cold for it. It is only by strict preservation that the breed of this beautiful and delicious bird can be kept up; for though if left alone it would undoubtedly find food, yet the attacks of poachers are so keen that unless it is protected it would soon be exterminated by them. It is supposed to have been first imported from the banks of the Phasis, a river of Colchis in Asia Minor (now called Mingrelia), from which it has derived its name. Its appearance is too well known to need description, but it may be mentioned that buff and pied varieties are by no means uncommon, a pure white bird being also sometimes met with. Pheasants are fond of thick underwood, especially where there are moist bottoms here and there, and brambles overgrown with climbing plants, in which are runs inaccessible to man, are their especial delight. They are polygamous in their habits, and the males begin to crow, in order to attract the hens, early in March. In April the eggs are laid, a very inartificial nest being made on the ground, generally at some little distance from the principal covert, and often in a hedge-row or in some small brake or spinny, where they are not likely to be molested by others of their own species. The eggs are on the average about twelve in number, of a pale olive brown, one inch ten lines long by one inch five lines in breadth. The weight of the cock pheasant averages about two and a half to three pounds, but instances have been known of its reaching to double the former weight. It is not very unusual to meet with a fat bird of four and a half pounds, but beyond this there is only one instance on record, namely, in *The Field* of February 25, 1859, where a cock pheasant weighing 5½ lbs. is said to have been killed by Mr. H. Akroyd, Bodington Park, Nantwich.

The pheasant readily breeds with the common fowl, and hybrids with the black grouse are sometimes produced. The modes of rearing and preserving pheasants, and the diseases to which they are subject, will be found described in the fifth book, as belonging to the duties of the gamekeeper.

The HARE (*Lepus timidus*), as existing in our woods and coverts, only belongs to one variety; the Irish hare and the mountain hare not being inhabitants of them. The RABBIT also (*Lepus cuniculus*), being well known, need not be

minutely described, as they are only shot in this kind of sport when they come in view while beating for pheasants.

PHEASANT COVERTS.

In various parts of England large coverts are planted almost with the sole view of affording protection to the pheasant. In Norfolk and Suffolk there are many sandy districts, where the fir is the only tree which will thrive, and, though rather an unprofitable one, it is planted in belts, which are particularly convenient for the purposes of the battue. Pheasants also are fond of roosting in these trees, partly because their limbs branch off at right angles from the trunk, and therefore form convenient perches, and partly because, being evergreen, they afford some protection from the rain in the cold winter months. Beech-woods are also favourite resorts for them, but in both instances there is a difficulty in getting sufficient underwood, and hence, wherever the nature of the soil is suitable, oak is preferred, especially as it is a timber which will pay better than fir. Ash is also pretty well suited to the purposes of the pheasant covert, but it has one great objection—in shedding its leaves so early that the poacher can see the pheasants perched on these trees a month earlier than on oak or elm. An undergrowth of hazel is one of the best, as it forms a thick protection to the game without tearing the clothes or face of the sportsman who crashes through the bushes in pursuit of his sport. In any case there ought to be rides cut, and for the battue these are doubly essential. There are, however, two varieties of coverts which are sometimes used for this sport; *firstly*, those which are planted specially for pheasants, and, *secondly*, those in which these birds are only incidental to the coverts, and then the proprietor does not sacrifice his pocket to his sport.

DOGS FOR PHEASANT SHOOTING.

It is now the fashion to drive the coverts with beaters, aided by a dog or two, or in some cases by a team of steady spaniels. In whatever way dogs are used, they should be broken to hunt close to their masters, and for this purpose

spaniels or beagles are the best kind. The Clumber spaniel is easily broken, and on that account he is preferred by many people, and being mute, he does not disturb the game far before him, for which reason he is well suited to battue shooting. On the other hand, for wild-pheasant shooting, a dog which gives tongue is able to indicate to the shooter the exact line which the pheasant he is on is taking, and is on that account more useful to him. Sometimes the setter is trained to beat a covert, a bell being fastened to his neck, which remains at rest when he stands. At best, however, he is a poor substitute for the spaniel. Beagles are used exactly like spaniels, and when well broken, they are quite as good; but they are too fond of "fur," and can seldom be induced to prefer "feather" to it. The three dogs which are represented in Book II. belong to the division known as "springers," the name being given from their being used in the "spring falls" of our coverts. The liver-coloured dog is the true Sussex spaniel. The lemon-and-white is known as the Clumber, and the black-and-white, in the background, represents the old Norfolk spaniel, a variety which is now dispersed all over England. Each of these will be more minutely described in the next book.

THE COVERT GUN.

Two things are essential to this kind of gun—firstly, rapidity of loading, and secondly, a length of barrel which will admit of its being used in covert without being caught by the branches. The breech loader with a barrel of twenty-eight inches in length, will be found to offer a combination of these good qualities, and such a gun is now in general use, among battue shooters especially. Some even cut the barrels down to twenty-six inches, but this is perhaps too short for practical purposes. The bore is generally a large one, few people shooting with a smaller than No. 12, and some adopting a still larger calibre. The size of shot is usually No. 5 or No. 6.

THE BATTUE.

When a party is made up for a day's battue shooting, the keeper or keepers must be allowed to have the assistance of

several beaters, the number being proportioned to the extent of the woods. When all is prepared—that is about ten or eleven o'clock—the keepers and beaters together drive the game towards the points where the guns are posted. The positions of these will be shifted from time to time, and will vary according to the nature of the covert which is being beaten. Thus, if belts are to be driven, the plan is as follows:—At each corner of one end of the first portion of the belt is stationed one gun, and its proprietor should be a good shot, furnished with a breech loader or with a second muzzle loader and a man to load it. Then outside the covert, and walking close to the hedge on each flank of the beaters, is another gun, making in all four, while a fifth may accompany them inside, walking a little in advance of them. When all is arranged, the beaters enter, and with or without a steady dog or two, they walk steadily in line, tapping the trees and uttering cries which are usually “Cock-cock,” or some similar words. These should be only loud enough to enable each to keep the line by sound, for excessive noise only drives the game away before the line come up. If a bird rises, the keeper, if he sees it, or a beater cries “Mark” or “Ware hen,” as the case may be, the latter being spared, unless the covert is over-stocked with them. If a gun is discharged, the whole line stop together till it is reloaded, when they proceed as before. Towards the end of the beat, the outside guns walk forward faster than the beaters, so as to reach the corner in time for the onslaught which may be expected, the pheasants here congregating till they are forced to rise, and then getting up rapidly one after the other, so as to occupy the attention of half-a-dozen men furnished with breech loaders, if the covert is ordinarily well stocked. After in this way beating out one portion of the belt, another is entered upon and driven in the same way. In large woods the beating is conducted on different principles. Here the shooters are stationed in the rides or on the edges of the springfalls, at such intervals as to command them without much risk of shooting each other. The keepers and beaters then drive the game towards these rides, and the hares and rabbits are shot as they cross them, while the pheasants are treated in the same way when they can be induced to rise;

or if not, they are driven towards the open springfalls, where they are afterwards found one by one, and shot as they rise. In this latter part of pheasant shooting, very pretty shooting often occurs, the spaniels hunting the pheasant's trail up to where each has squatted, and displaying the good qualities of the dog to great perfection. As soon as one portion of the wood is beaten, the shooters are moved on to another, until the whole wood is exhausted, and then the day's sport is at an end. Sometimes the wood is netted off by low nets being run across it from one outside edge to the opposite one, and as pheasants never rise over these without going above the trees, and therefore in shot, they are successful in causing them to run to the outer boundary, where the expectant guns are posted. The slaughter in this mode of shooting is immense; but as few game preservers shoot their woods more than twice or thrice a year, the object is to let as few escape as possible, and hence good shots and breech loaders are at a premium.

WILD-PHEASANT SHOOTING.

When these birds are only partially preserved, their numbers are not sufficient to warrant the invitation of a party for the purpose of a battue, and the shooter goes into the woods alone, aided by a couple or two of good spaniels. These being taught to hunt within gun-shot of their master, give him notice when they are on game by their tongues, and as he rushes forward to them (which he must do as rapidly as possible, *malgré* bushes, thorns, and brambles), they push up the pheasant, and on its rising, it is knocked over if the sportsman is fortunate enough to get a shot. A good dog well broken to this kind of shooting will give his master notice, and then work very steadily on the line of his game till he knows that the gun is at hand, when he dashes forward and is almost sure to make the previously running bird take to his wings for fear of losing his tail in the jaws of the spaniel. In extensive woodlands this is a most exciting sport, and with a strong and active man provided with a team of steady dogs, a goodly number of the pheasants which are found may be brought to bag. But scarcely any species of sport requires more complete correspondence

between the dogs and their master, and none except deer-stalking is more trying to the wind and muscles. If carried on sleepily and unscientifically, few shots will be obtained during the day, so that it is scarcely to be wondered at that it is abandoned by those gentlemen who only occasionally indulge in rural amusements.

HEDGEROW PHEASANT SHOOTING

Early in the season, pheasants may often be found in the hedgerows near the coverts, especially if these are hunted in the morning, about eight or nine o'clock, when the birds are returning from their feed. The spaniels should be made to hunt them *from* the covert, or the birds will run before them into their secure retreats, and refuse to rise. If the hedge is a high one, a shooter should be on each side, or if there is only one gun, he should be on the ditch side. Pheasants also are fond of small ash-beds and other coverts of trifling extent, where they remain quiet until they are driven into the more secure preserves by the keepers. In such places they are often to be killed in the first days of October, at a time when the larger coverts are too full of leaf to admit of their being beaten.

COCK SHOOTING.

The WOODCOCK (*Scolopax rusticola*) presents one of the most difficult shots which can fall to the lot of the British sportsman. This arises partly from the nature of the thick coverts which he frequents, and partly from the quick shoots which he makes round the trees as he rises from the ground. This bird occasionally breeds in Great Britain, but the bulk of those found in the winter here have migrated from the north of Europe, arriving in flights early in October, and leaving us in March. Mr. Campbell, of Kilberry, who is one of the most successful cock shooters of the day, is of opinion that within the last ten years they leave Scotland earlier than formerly, and he has known them during that period pair in the middle of February. Mr. Selby, who made his observations in Northumberland, observes "that the first flights of these birds, which seldom remain longer than for a

few days, and then pass southward, consist chiefly of females; whilst, on the contrary, the subsequent and latest flights which continue with us are principally composed of males. It has been noticed by several authors, that the arrival of the males, in a number of our summer visitants, precedes that of the females by many days; a fact from which we might infer, that in such species a similar separation exists between the sexes during their æquatorial migration." The woodcock is essentially a nocturnal bird, remaining by day under thick bushes or other dense covert on the ground. In the evening it leaves its retreat, and flies silently to its feeding-ground, where worms and insects are carefully sought for in the moist earth by boring with the bill. The nest is built on the ground in dry grassy situations. The female lays three or four eggs, similar in size and shape to those of the plover; in colour, of a pale yellowish white, the larger end blotched with ash grey and reddish yellow brown; length one inch and three-quarters, breadth one inch four lines. Yarrell's description of the woodcock is as follows:—Beak dark brown at the point, pale reddish brown at the base, and generally about three inches long; the irides dark brown; eye large, convex, and prominent; from the beak to the eye a dark-brown streak; the colour of the plumage is a mixture principally of three shades of brown—namely, pale wood brown, chesnut brown, and dark umber brown; each feather on the upper surface of the body contains the three shades, but so disposed as to produce a beautifully variegated appearance. The cheeks pale wood brown, spotted with dark brown; the forehead to the top of the head greyish brown, occiput and nape rich dark brown, transversely divided into three nearly equal patches by two bars of yellow wood brown, each feather of the neck below pale brown, edged with dark brown; the back, greyish brown varied with reddish brown, and dark umber brown; all the wing coverts reddish brown, with open oval rings of dark brown; primary quill feathers blackish brown, with triangular spots of pale reddish brown along the margins of each web; secondaries and tertials of the same ground colour, blackish brown, but the light-coloured marks are more elongated, and extend from the margin of the web to the shaft

of the feather ; rump and upper tail coverts chesnut brown, tinged with grey and barred transversely with dark brown ; tail feathers black above, tipped with pure dark grey ; chin very pale yellow brown ; neck in front, breast, and all the under surface of the body wood brown, transversely barred with dark brown, both shades on the under surface becoming lighter in old birds ; under wing coverts pale brown barred with dark brown, under surface of the quill feathers dry slate grey, the triangular markings yellowish grey ; under surface of the tail feathers nearly black, tipped with delicate snow white ; legs and toes livid brown, claws black. The length of the bird is about fourteen and a half inches. The females are larger than the males, and have the upper part of the back more black, and the lower part of it more red than in males. These latter have also a more grey forehead, and the chin white. The weight varies a good deal according to the condition ; seven ounces is probably the lowest weight, and twenty-seven ounces are recorded as having been the weight of one killed in 1775, at Narborough, on the authority of Lady Peyton, who saw it weighed. This is quite exceptional, and sixteen or seventeen ounces are, I believe, quite the outside weights. Woodcocks are occasionally met with pied, and also of a buff or dirty white colour. It is now generally admitted, that the woodcock carries her young on her feet from her resting place to the feeding ground.

THE HAUNTS AND HABITS OF THE WOODCOCK.

*In the south of England it is useless to look for these birds anywhere except in coverts, some of which are known to be annually frequented by them, while in others they are rarely met with. They prefer large woodlands with plenty of brushwood, where they can be undisturbed, but are sometimes found in small coppices close to the habitations of man. In the north they are sometimes to be seen in considerable numbers in long heather, where, Mr. Campbell remarks, they generally choose the shady side, the reverse being the case in covert. The following observations on this subject are from the pen of Mr. Campbell, as recorded in *The Field of**

April 21, 1859, and that gentleman having recorded in his game book 4102 cocks as bagged to his own gun, may be received as a high authority in this, as indeed in all other departments of the sport :—

“In ordinary weather, unless a cock has already been flushed on that day, he sits very close ; but if once flushed, he is difficult of approach in covert ; and if he takes to the heather ‘by chance,’ you may happen to get a shot at him the second time he is flushed ; but after then you had much better give it up—it is only waste of time. Other game birds which I have shot often are brought into subjection—even the wildest of grouse and black-cocks—by perseveringly following and shooting at them. They begin wild and end tame ; but the woodcock pursues the other course, beginning tame and ending wild. You shall see grouse, black game, partridges, and woodcocks occasionally flushed by being walked over by cattle or sheep. Of all those the woodcock flies by far the shortest distance invariably. He appears to consider his having been disturbed an accidental circumstance, and in the first instance takes it as such ; but if he has any idea that there is ‘any trick in it’ he will very soon show you that he is rather better up to tricks than you are.

“A woodcock is always more difficult of approach in a thaw than in any ordinary weather. The greatest number of woodcocks I ever have seen in a day have been flushed on the first day of a thaw succeeding a long frost. In that weather I often have seen a great many woodcocks. Next day go and hunt the whole country, high and low, and you wont see one cock. In that weather I have been driven home twice in the course of a very short day—wet to the skin from wet snow, almost blinded by a gale of wind—in order to wash out my gun, which had frequently missed fire. I think I must have had fifteen or twenty miss-fires. On this occasion I sent twenty-seven woodcocks into the game-larder. I went out next morning and beat the whole country round, high and low land, and did not see the feather of a cock. In similar circumstances I have found it invariably so.

“I have often heard it remarked that a woodcock is a

stupid bird because he will sometimes fly right at you. I don't think a hare is a stupid animal, yet she will often run directly towards you. I have observed that the position 'in the head' of the eyes of a hare and of a woodcock are very similar. I have heard that that circumstance prevents either animal from seeing straight before it.

"So far from being a stupid bird, I know of no bird which possesses sagacity to be compared with that of a woodcock. The means of escape to which, when pursued, he resorts are worthy of the highest meed of commendation which his pursuers can bestow on him. At present I abstain from quoting remarkable instances which have come under my personal observation of the sagacity displayed by woodcocks whilst engaged in the natural act of self-preservation, for the reason that the facts which would be read with great interest by men who know what woodcock shooting is, might probably not command the same degree of respect from those who are not conversant with the subject, and whose acquaintance with the woodcock has either been in a poulterer's shop or on the table.

"How often have I heard the absurd remark, in talking of a covert, 'Oh yes, it must be capital covert for cocks, it is so full of springs.' What has a cock to do at a spring, except in a long and severe frost, when he may be starving? Like all our land-birds, except a snipe, a woodcock likes to lie dry, and, unless disturbed, remains in his resting-place during the day; towards night flying often to a great distance to his feeding-ground, which generally is open, soft, grassy land, particularly that pastured by cattle, as muddy adjacent ground, springs, or the rivulets flowing from them, are not the natural feeding-places of a woodcock.

"In ordinarily open weather a woodcock satisfies himself with food at his natural feeding-places during the night, returning in the morning to his dry resting-place; but often it happens that in very severe frost he is unable to feed himself to his satisfaction during the night, and goes about during the day also, seeking for some soft grounds into which he can poke his beak, which, of course, he does not find except at or near a spring; but when he is found trying to feed at a spring during the daytime you will find he is so

much reduced as not to be worth shooting. It is curious to observe how few days of very hard weather reduce a woodcock to something very much like a skeleton; and also how few days of open weather restore him to excellent condition. A woodcock feeds in an extraordinary manner; he seems never to be at rest for a second of time, running very fast, and poking his beak into the ground with a degree of rapidity almost inconceivable. I don't know what they feed upon, but think their natural food consists of small worms and insects. In very hard weather, however, he will poke his beak into almost any soft substance. A few years ago, during a severe frost, my cook went out one forenoon to the meat-larder, which is at a distance of about fifty yards from the house, for a roast of beef, to be prepared for dinner; having cut what she required, in the hurry of the moment she left the remainder on a block of wood which is by the larder, returning to the house; in about three minutes she paid a second visit to the larder for the purpose of cutting a steak, when the beef had disappeared and was not to be found. It appears that the shepherd was passing by with his dog, which ran off with the beef. Missing his dog, the man called and whistled, upon which the dog dropped the beef and returned to him. Late in the afternoon a sportsman who was staying with us, on returning home from shooting, stepped over a low wall enclosing a small plantation close to this house, when *three* woodcocks rose almost from under his feet. He shot at two and killed one; at his feet he found the missing piece of beef, and brought it home, completely perforated by the woodcocks' beaks. I had in the morning beaten the plantation, of scarcely an acre in extent, very carefully; found four cocks in it, and killed three of them—two of the three which he saw must have come from adjacent plantations in search of food. It has often occurred to me that there exists much less sympathy between woodcocks than between any other birds I have shot. In most other game birds I have observed that they generally, when flushed, pursue nearly the same course, and if one of two or more be wounded, the other, or others, very often sympathize so much with their comrade as to light near the spot where he, from exhaustion,

pitched. In my experience I never have seen any instance of the sort in woodcocks. Woodcocks, even paired for the purpose of breeding, when flushed, pursue courses as nearly opposite as possible.

"A woodcock is the most silent bird I know. Other game birds very generally call when flushed—a *black-cock*, however, very seldom, except in covert. A woodcock occasionally, though very seldom indeed, calls. When I have heard him do so, it has generally been at the approach either of night or of a heavy fall of snow. The call is not musical, though magically game-like—once heard never again to be mistaken for the call of any other bird. In flight-time at night and morning they constantly call, and may be heard a long time before they are seen.

"In this country woodcocks are found either in covert or in long heather. A strange peculiarity exists with regard to the finds for woodcocks—in covert, generally on the sunny side, on banks facing the south-east; in the heather, very nearly invariably the reverse is the fact—you won't find one cock in long heather, on the sunny side of a heathery hill, for some hundreds you will find on the side which never sees the sun in the winter time. On those shaded hill-sides, and in the adjacent heathery and brush-wooded burns, I have enjoyed most excellent sport.

"I think a woodcock is generally more easily brought down in covert than in the open. In covert you take great pains to do it well; in the open you imagine the shot to be a much more simple one than it is."

A south-country sportsman has also given us the results of his experience in the same periodical in the following terms:—

"On bright moonlight nights woodcocks all leave the thick coverts of wood and copse about the hour of twilight, and betake themselves to the open downs and hills, meadows, fields, and plains, to feed, returning in the morning as daylight appears to their former coverts. At the head of a long wooded valley, in the twilight if a moonlight night, the woodcocks may be seen, many of them together, to play about like swallows in the air at about the height of a church tower for

some minutes, and then depart to their several feeding-places on the hills and downs; and towards the morning's dawn, upon their return, they will again circle around in company at the head or entrance of the goil or valley ere they retire to their separate quarters in the woods. This they will do night after night during the continuance of the moon, if not disturbed in their passage by being fired at—a too common practice, I am sorry to say, on moonlight evenings in this neighbourhood. But the gun is not the only engine of destruction awaiting the poor cocks on their moonlight peregrinations.

“It used to be the constant practice on all the hill downs in these parts to place cut underwood or furze, about a foot in height, to a very great extent along the ground, in the shape of the letter V, at the apex of which an opening would be left where a hair-noose or springle would be set, which seldom failed to yield the pot-hunter a nightly supply, as the cock would run along the side of the brushwood feeding, not taking the trouble to top over it, until he was led into the snare; but this plan is now, owing to the scarcity of cocks when compared with former years, very seldom practised.

“But to return to my point. On regaining the woods, after his moonlight wanderings, the woodcock drops like a stone into his bush, and immediately goes to sleep, continuing immovable, unless disturbed, until about three o'clock in the afternoon, when he begins to move a *little* round his cubiculum. On these days, after moonlight nights, woodcocks are very difficult to find in covert—that is, they lie very close, frequently allowing man and dog to pass within a very few feet of them without moving; and now it is when a first-rate cocker is invaluable, and manifests his superiority in winding the sleeping cock on coming within a gun-shot of him, when perhaps ten other cockers, first-rate dogs for finding the cock by the scent which his running and feeding leaves behind him, will pass by within a few feet without noticing the bird in the slightest degree.

“On dark nights the woodcock never leaves the covert, nor does he feed at all during the night, but sleeps throughout the silent hours; but on the first dawn of day he begins

to move about and feed without leaving the wood or copse, and generally without taking wing at all, working his way for the most part upwards if the covert is in a valley or on the side of a hill. On bright days they do not move nearly so much as on dark days; and I have invariably found, as a rule, that my sport has been inferior on bright sunny days to what it has been on dark and gloomy ones.

"In decidedly misty weather the woodcocks are much more on the move than even on dark and gloomy days, and certainly take wing continually, feeding for an hour perhaps in one place, then flying on for about 100, 200, or more yards, then feeding again, and then taking another flight; and generally, I think, working up towards the open country. On these misty days I have been sometimes disappointed in finding the cock at all, especially if not out in the morning, though perhaps I have hit on two or three places where he has been feeding during the previous part of the day; though frequently, on the other hand, by knowing the ground well, I have at last overtaken him.

"JAM SATIS."

DOGS EMPLOYED IN COCK SHOOTING.

Spaniels of all kinds are used in cock shooting; but the smaller kind known as cockers, from being devoted to this sport, are most suited to it, in consequence of their being able to follow out the runs in the thick coverts better than the larger kinds generally known as springers, and kept for pheasant shooting. Two or three couple of cockers are hunted together, and when well broken they afford good sport, but the most successful cock shooters prefer using beaters almost unassisted by the dog. An excellent nose is a *sine quâ non* in the cocker; but more than this is wanted, as is very ably shown by the writer above alluded to under the signature of "Jam Satis."

"There are some dogs," he says, "that seem to have a most extraordinary instinct for finding the sleeping or lying cock, and get greatly excited, and rush towards his hiding-place, and flush him with a spring and a howl of delight. These are the dogs for finding a cock that has dropped into

short thick gorse, and will, as a rule, never fail to find him a second time in covert if they have seen, or have the direction of his flight given them. The dogs I have had, endowed with this faculty, have been generally half-bred, sometimes between a spaniel and a setter; but they are very few and far between. I think much depends on their having first-rate brains, noses of a *ne plus ultra* quality of course, carrying their heads high in the air, and being entered and kept to cock shooting, and little else, with constant practice; and I have observed that the dog that finds the sleeping cock in the way above described, finds him in a similar manner, although he may have been running about the woods feeding all the day, and left a quarter of a mile of trail and scent in his path behind him—finds him, that is, not by hunting up his scent, but by a kind of instinct."

The group which faces this page consists of an old-fashioned Welsh cocker, which closely resembles the Devonshire dog, both being of a rich liver colour; and an ordinary liver-and-white cocking spaniel, such as is met with throughout England without any peculiar designation, and variously bred. Indeed, with the exception of the Welsh and Devonshire strains, there are no cockers now with any pretensions to purity of blood.

THE GUN FOR COCKS.

The *ordinary covert gun*, as described at page 59, is the weapon which is used for this kind of sport. Cocks do not carry off much lead, and therefore a particularly hard hitter is not required. Nor is a breech loader so pre-eminently serviceable as in pheasant shooting, because the cocks are not driven up into one corner, as they are in the battue; still, it is occasionally serviceable, from the power of loading it more quickly than the muzzle loader. No. 7 is the proper size of shot.

THE FINDING AND KILLING OF WOODCOCKS.

Mr. Colquhoun is so practised a hand not only in finding and killing cocks, but also in describing what he has seen and done, that I cannot do better than let him speak for himself in the matter. He says:—

“Irrespective of the woodcock being the most difficult bird to bring down which Scotland affords, there is a sort of charm attached to cock shooting which even to a penman would, I think, be difficult to describe. In the first place, the almost extra high physical condition which the bracing and invigorating air, peculiar to this coast, imparts in the enjoyment of this fascinating sport, independently of increased mental energy and higher spirits; the great variety of rugged, wild, grand scenery which is presented; the unmistakable rattle of the cock's wings as he rises, followed by the magically-sounding words, ‘Mark cock!’ are, when taken together, rather apt to produce an effect contrary to that of strengthening the nerves. I have met with many men, particularly young ones, and especially when over their wine, who attempted to lay down the law at great length—‘Let me assure you, old fellow, you are mistaken; there is no bird more easily shot than a cock.’ I never yet have seen one of those talkers whose performances on the following, or on any other day, did not present a sad contrast to his professions. But they are always handy with excuses of various descriptions: ‘The effects of the smoking room on the previous evening;’ ‘That infernal toasted cheese;’ and, if nothing else will go down, the gunpowder is damp—‘I won't have any more of that fellow's gunpowder.’

“Those excuses may be well enough got up, but are of no use, because there is no doubt of the woodcock's being the most difficult bird to shoot of all those we know in Scotland.

“Ask the best shot you know—one who has had great experience in all sorts of shooting which Scotland affords—ask him how many hill or low-ground game birds he ever has consecutively bagged, taking all birds as they rose within shot? Then ask him how many woodcocks he has under the same circumstances bagged? You will find the latter *one* to the former *three*. Then, it will be said, that in covert woodcocks are protected by the trees; so they often are, but trees nearly as often present an obstacle as a protection to them.

“For many years past I have observed most accurately the shooting of a man who, I think, is a very good shot. I have seen him bag some thousands of both woodcocks and

moor and other game; I have seen him, in circumstances extremely disadvantageous to himself, bag twenty-nine grouse and old black-cocks in as many consecutive shots, taking every bird as he rose; he then stopped early in the day and went home. The thirtieth bird required the second barrel, and that broke the ice. Although I have seen him bag thousands of woodcocks, I never saw him bag more than nine consecutive shots, taking every bird as he rose within shot. I saw him on one day, in difficult covert, flush twelve woodcocks and a snipe *only*; he took every bird as it rose, and brought them all home—only the ninth cock was the better of the second barrel. I have seen him have nearly fifty fair shots at woodcocks in a day; but never have seen him bag more than nine cocks consecutively; and I never have seen any other man kill as many.

“The difficulty of woodcock shooting is so evident to every one who has had experience in it as to render any remarks of mine on the subject unnecessary; but to those sportsmen who, to their own loss, have not had much of this sport, I may remark that the flight of a woodcock is very much quicker than a novice would be led to suppose, from the apparently slow movement of his wings; then, in about the best of woodcock ground, your footing is very insecure; and, when the frozen-over brooks and pools of water, which you must continually cross, are covered with a coating of snow, you require quite as many hands and legs as you are possessed of to save your gun and your head from destruction.

“In moor and general open game-shooting there is very little variety in the appearances of shots which are offered to you. The variation is between a shot going right away, and one crossing you either more or less; but in woodcock shooting there is an almost endless variety of shots offered, very seldom indeed two of the same description presenting themselves in succession—now descending almost perpendicularly over your head from a high overhanging cliff, with a degree of rapidity almost inconceivable; then descending from the top of a precipice, over which you are standing, with equal velocity, to a very great depth below; again, suddenly appearing within five yards of you, flying (at the same rate) right at you, and passing over your head within

a few yards of you, almost instantly dodging behind a rock or tree, and no more seen of him.

"It would be endless to attempt to describe the variety of shots which present themselves to a woodcock shooter in this country. I neither pretend nor presume to interfere with the observations of gentlemen who have been accustomed to shoot woodcocks in champagne districts, such as in plantations of larch or fir of a moderate height; but to do even that well requires practice. My woodcock-shooting experience extends little beyond a very rugged part of the West Highlands of Argyllshire, comprising a good deal of open shooting in heather and short brushwood; but I can't say it is easier than shooting in covert.

"Woodcock shooters enjoy two considerable advantages—the one is, that very little shot brings the bird down; and the other is, that a wounded woodcock, if unable to fly, is the least running of all birds I have shot, and is easily recovered.

"I have generally shot woodcocks alone, and have been accustomed to make all my arrangements; consequently, if anything goes wrong I know who is to blame. I like to use No. 7 shot, and to be accompanied by three beaters and a well-nosed, slow-going dog of the retrieving species. My beaters must be strong and active men, well fed and well clothed, and wearing strong leather gloves, each carrying a stout walking-stick, with which the trees and stones are smartly struck as the man goes along. I never allow a word to be spoken, except "*Mark!*"—that remnant of ignorance, "*Whirr cock,*" is, I am glad to observe, fast falling into disuse, and for many years past has been totally disused in my coverts. The sound of all the bacchanalian-like screeches—which I so often have been condemned to listen to—tends directly to defeat the object of the yellers. In a covert so beaten I have observed that roe-deer, hares, and pheasants sit close, allowing the howlers to pass them, when they start and run back. Woodcocks also sit close, and when the beaters have passed, take wing and fly back. If a game-keeper wishes to save his birds, let him instruct his beaters to make as much noise as they can; but if the object is to show game, even the foot-fall (if possible) of a man should

not be heard; a sharp crack of a stick against the trees, but not too frequently repeated, will show you more game by far than the howling system.

"I have had forty consecutive years of experience of woodcock as well as all other shooting which Scotland affords. I never have kept a note of birds killed by me except of woodcocks, and of them only for the last thirty-three seasons. During that space of time my sport has been extremely variable, from want of favourable seasons and other circumstances. In three seasons, taken together, I have killed 43 woodcocks; and in three others, 885. I have my register by me; and in the last thirty-three years find I have bagged, besides all other sorts of game, 4102 woodcocks; and may remark that during that space of time I never have seen anything occur worthy of remark beyond my having often missed when I did not expect to have done so, and sometimes killed when I did not think I should have done so. My two best consecutive days, 'shooting alone,' were 37 cocks one day and 27 the other—64 birds in two days. I killed 130 cocks in ten consecutive days' shooting."

RABBIT SHOOTING.

Rabbit shooting is a different affair altogether from shooting hares, and affords, in my opinion, the very best sport in covert of all, excepting only wild pheasant and woodcock shooting. This, of course, has reference to the hunting them with dogs, and shooting them while going at their best pace, which is undoubtedly a racing one. Rabbits breed in warrens, in hedgerows, and in covert, and multiply very fast indeed. There are said to be several distinct varieties; but I believe there is no truth in the assertion, the kind of food only causing a *temporary* difference, and not permanently causing a distinct variety. Warren rabbits removed to a covert, and there allowed to breed, soon attain the same characters as the prior denizens of the same locality. The sport of shooting rabbits is never carried on in the warrens, because the warrener does not wish his property wasted, and prefers trapping them, for obvious reasons—one being, that the wounded rabbits often escape into the holes and die out

of reach. In hedgerows, they may be hunted with spaniels or terriers, and shot as they come out; but they generally have holes in the banks, and then soon reach them in safety. When driven to their fastnesses, the ferret is the only resource; and these animals, after being muzzled, soon drive them either to the gun or into bag-nets placed over the holes. But it is to the covert-shooting of rabbits that I wish to draw attention, that being the only kind of rabbit shooting which is to be considered deserving the attention of the true sportsman, and which, I have already remarked, is really worth it. Rabbits are now much encouraged in large pheasant preserves, partly for the sake of the keepers, whose perquisite they are, but chiefly because they afford food for the foxes preserved for fox hunting, which would otherwise prey upon the pheasants. The keeper feeds foxes when young regularly upon rabbits wounded and left near their earths; and, consequently, these rabbit-fed animals keep to the same fare, and are thus prevented from interfering with the pleasures of the *battue*. The keeper continues to shoot a few outlying rabbits round the covert, and those which are thus wounded suffice to keep up the supply for the foxes, in addition to those which the keeper may purposely leave for him, or the fox may himself succeed in laying hold of. When the pheasant season is over, and the foxes also have been thinned, it will be found that the rabbits must be kept down on account of the young crops, which they begin to bite off most cruelly. In February and March, therefore, good sport is usually afforded by this thinning of the rabbits, several hundred couple being often killed in a single preserve. At this time a great number of rabbits lie above ground, preparing for their young, or driven to seek the pleasures of love, or from other causes, of which we, in our ignorance of their language, have not yet fathomed the motive. However, there they are; and in the springfalls of a large wood they may be found lying in tussocks of grass, or in little bushes. For these the vermin terriers of the keepers are the best dogs, as they hunt them very quietly, yet strongly, and your regular springers or cockers would be utterly spoilt for pheasant or cock if allowed to hunt rabbit. By sending the keeper and his terriers into the wood, the rabbits are driven

across the drives, where the guns should be posted at sixty yards' distance from one another; or, if the springfalls are quite open, they may walk them in line. As the rabbits are put up, they cut in and out of the rides or runs, and require great quickness of eye to catch them before they are lost to sight. The guns must be carried on the arm full-cocked; and great care must be taken not to shoot the terriers as they are hunting close upon the scut of the rabbit. I once shot a very valuable dog in this way, with the rabbit actually in his mouth. This was as the rabbit was coming out of a bush, and the dog so close upon her, that, as she sprang through, the terrier did the same, and received my charge in his breast, killing both dog and rabbit. It is needful to shoot well before the rabbit, as they run so quickly by you, that if you do not take this precaution you are sure to shoot behind them. The knack is easily acquired by a quick eye and hand, but a slow man had better not attempt what he will be certain to fail in.

RABBIT-SHOOTING DOGS.

Terriers of all kinds are employed in this kind of sport, with or without ferrets. In the illustration given in the second book are examples of those most commonly used, consisting of the smooth black-and-tanned dog with a slight cross of the bull to make him stand the severity of the work which he has to accomplish; the Dandie Dinmont, which is an excellent rabbit dog; and the Scotch terrier.

CHAPTER V.

WILDFOWL SHOOTING.

SHOOTING FLAPPERS—INLAND WINTER SHOOTING—MARINE
WILDFOWL SHOOTING.

VARIETIES OF WILDFOWL.

THE varieties of wild fowl which are occasionally shot on the rivers, ponds, lakes, and coasts of this country, are so great as to defy anything more than a bare enumeration in a book like the present. Some few, however, of the more common kinds may be cursorily alluded to, and the remainder summed up in a bare catalogue of names.

The following terms are in use among wildfowl shooters:—A flock of widgeon is termed "a company;" of swans, cranes, and curlews, "a herd;" of teal, "a spring;" of geese, "a gaggle;" of ducks, "a badelynge;" of mallards, "a sord;" of coots, "a covert;" of sheldrakes, "a dopping."

The WILD MALLARD and DUCK (*Anas boschas*) is supposed to be the original of our tame ducks, which have changed their colours in many cases and have also increased in size. The Rouen variety is, however, very much like the wild duck in colour, and there can be little doubt that it is really a domesticated *Anas boschas*. There is, however, one point in which they differ, and that a most important one, which would almost lead to the belief that they are distinct in their origin. I allude to the fact that the wild duck pairs, while the tame duck is polygamous. It is scarcely necessary to describe minutely the appearance of this bird, as it differs little from the tame duck known as "the Rouen," except in size. The drakes are twenty-four inches long, while the ducks measure only twenty-two. They feed on grain and grass seeds, worms, young frogs, insects, and fish. The nest is made of grass, lined with down, from the breast of the parent bird, and is placed on the ground, either on the banks

of some inland water, or often at a considerable distance from it. A double hedgerow is a favourite place for their nidification, and instances are recorded of a pollard tree having been chosen for the purpose. The duck lays about fifteen or eighteen eggs, which are of a greenish white colour, two inches and a quarter long, by one inch seven lines broad. The young ducks take the water soon after they are hatched, but they are at least two months old before they can fly. At this time they are called "flappers," and are shot, on account of their delicacy, for the purposes of the table. They are generally to be found on the brooks and rivers frequented by them about the latter part of July, varying from the 15th to the 31st, according to the season. Besides the wild ducks bred in Great Britain, great numbers migrate to our rivers and coasts in the winter season.

WIDGEON (*Mareca Penelope*) come next to the wild duck in size and importance to the sportsman. They very rarely breed here, but migrate to us from the north of Europe in large flocks, which begin to come over in the end of September and beginning of October, and leave us in March and April. They resemble the wild duck in most of their habits, and like it are monogamous. A whistling noise is made by them which may be heard for some distance, and marks their presence to those who have once heard it. The inland waters of this country are seldom frequented by this bird, which is found in large flocks on the coast, where it forms one of the chief objects of search by the puntsman. In the adult male the bill is brownish black, tinged with lead colour; iris dark brown; a green streak passes backwards from the eye; forehead and top of the head a creamy white; cheeks and back of the neck a rich chesnut; upper parts greyish white, crossed with irregular lines of black; upper tail coverts freckled with grey; tail pointed and nearly black; wing coverts white, tipped with black; primaries uniformly of a dark brown; secondaries the same, but their outer webs form a green speculum tipped with black; tertials have their outer webs edged with white; chin and throat black; lower part of the neck pale reddish brown; sides and flanks marked with transverse lines of brown on a white ground; breast, belly, and vent white; under tail

coverts black ; legs and toes dark brown. Length eighteen inches. The females and young males have the bill bluish black ; iris brown ; head and neck light brown, tinged with red, and speckled with dark brown ; feathers of the back dark brown on the centre of each, with paler edges slightly tinged with red ; wings and tail like those of the male ; the whole under surface white. The nest is made among rushes or sedge, and the female lays from six to eight eggs, which are of a creamy white, two inches and an eighth in length, by an inch and a half.

The TEAL (*Querquedula crecca*) is the smallest of British ducks, but on account of the delicious flavour of its flesh, it is one of the most highly valued. Like the widgeon, though more frequently than that bird, it only occasionally breeds here, the immense flocks which are found in severe winters on our waters migrating from the north. These begin to appear in September, and leave in March or April. Its flight is rapid but uniform, so that a good shot may be sure of his mark. The nest is made among rushes, of a mass of vegetable matter lined with down and feathers, and usually contains eight or nine eggs, sometimes, but rarely, twelve. The male has the beak nearly black ; iris hazel ; forehead, and a narrow band over the top of the head dark chesnut ; a narrow line of buff extends backwards from the gape, and this dividing in front of the eye, passes above and below it to the nape of the neck ; between these two lines is a patch of dark glossy green ; cheeks and sides of the neck below this patch chesnut ; upper parts white, barred with narrow transverse lines ; wings brown in various shades ; a speculum of green, purple, and black on the secondaries, tipped with white ; tail dark brown and pointed ; chin black ; front of neck chesnut above, with spots of black on a white ground below ; legs and toes brownish grey. Length fourteen inches and a half. The female has the whole of the head speckled with dark brown, on a ground colour of light brown ; after part of back and scapular dark brown, each feather having two transverse bars of buffy brown ; wing like the male, but the speculum is blacker and without the shade of purple seen in the male ; chin pale brown ; lower part of the neck varied with two shades of brown in crescentic

marks ; breast white ; under parts dull white, spotted with dark brown.

The POCHARD or DUNBIRD (*Nyroca ferina*) is also a winter visitor, first coming over in October and leaving in March. It is a very shy bird, and frequents fresh water as well as our sea-coasts and bays. The flesh is of excellent flavour, and is highly prized for the table, resembling the famous canvas-backed duck of the United States, though but a humble imitation, in my opinion. The length of this duck is $19\frac{1}{2}$ inches. The male has a pale blue bill with a black point and base ; iris red ; head and upper part of neck rich chesnut ; lower part of neck and upper part of breast deep black ; back of a freckled grey ; rump and upper tail coverts black ; tail greyish brown ; lower breast and belly grey ; legs and toes blueish grey. The female has the bill all black ; iris brown ; head and neck dusky brown ; lower part of neck and breast dark brown.

The PINTAILED DUCK (*Dafila acuta*) is also occasionally found on our internal waters, and is one of the first taken in the decoys in October. It is, however, chiefly a frequenter of our creeks and bays. It is not common in Wales, nor is it often met with on the south-western coast of Devon and Cornwall, but from Poole Harbour to Lymington it is frequently seen, and has obtained there the name of the sea-pheasant, from its peculiarly shaped tail. As its flight is extremely rapid, it is not a very easy shot, but it is not so shy and difficult of access as the widgeon. It forms its nest in rushes and strong herbage, where it lays seven or eight eggs of a greenish-white colour, two inches and one line in length by one inch five lines in breadth. In winter the adult male has the bill lead grey on the sides, the central ridge and base being of a brownish black ; iris dark brown ; head and neck dark brown, the feathers on the back of the neck being tinged with purple ; upper parts a rich grey, formed by a mixture of fine lines of black and white ; primaries greyish brown ; secondaries black, with a speculum of dark green ; tertials elongated, black in the centre, with a white outer margin, and the inner one grey ; tail coverts ash grey ; elongated tail feathers black ; short ones dark brown, edged with white ; a white stripe on the side of the neck,

running up from the breast to the ear coverts ; sides grey ; vent and under tail coverts black ; legs and toes blackish brown ; length from twenty-six to twenty-eight inches. The female has the head reddish brown ; neck pale brown, both being speckled with very dark brown ; upper parts dark brown, each feather being black in the centre with a pale brown edge ; under surface of a pale brown, as in the case of many other ducks. In July the male assumes the same plumage as the female, but recovers his masculine colours in the autumnal moult. The length of tail will always serve to distinguish this duck from the widgeon, whose plumage it resembles in other respects. The flavour for the table is excellent, and the bird bears a high price in the poulterers' shops.

The MOORHEN or GALLINULE (*Gallinula chloropus*) is very commonly met with in our rivers and ponds, where it swims gracefully, searching for aquatic insects, and nodding its head at every instant. It dives remarkably well and quickly, and remains in the reeds with only its beak above the water. On account of its diving so rapidly, it is rarely bagged without the aid of a dog, as it does not rise to the surface if death takes place under the water. On land it runs rapidly, cocking up the feathers of its tail, which are white beneath, and seeking the secure retreats afforded by the water as rapidly as possible. Its nest is built among the sedge, and it lays seven or eight eggs of a yellow colour with brown spots. The young birds appear only like a brownish black mass of fur or down, and swim about in the most lively manner. In the male the beak is yellowish green, with a red base ; on the forehead is a naked patch of red ; iris hazel ; back, wings, rump, and tail dark olive brown ; head, neck, breast, and sides dark slate ; belly and vent greyish white ; above the tarsus a ring of red ; legs and toes green.

The WATER-RAIL (*Rallus aquaticus*) resembles the moorhen in general figure, though differing in colour, which is more like that of the land-rail. The back is spotted or speckled brown ; cheeks, chin, sides, and front of neck and breast lead grey ; vent buff colour ; legs and toes brownish red ; length eleven inches and a half.

The GREBES (*Podiceps cristatus*, *P. auritus*, and *P.*

minor) are like the moorhens in diving powers, and resemble them much in habits. All the grebes feed upon fish and water insects. The lesser grebe is also called the *Dabchick*. It is a very timid bird, and disappears by diving on the slightest alarm. It is easily domesticated on our ornamental waters, and dives and comes up again, over and over again, as if for the amusement of the spectators.

The COMMON COOT (*Fulica atra*), of which the GREATER COOT is only a variety, is constantly met with on our internal waters, and also to some extent upon our sea-coasts. Indeed, on the Southampton Water it is common enough, as well as in the creeks on the coast of Essex. It breeds in this country to some extent, but also migrates from the north. The nest is formed of flags, &c., among the reeds or rushes, of a clumsy but compact form. Here the female lays seven or eight eggs of a stone colour, two inches and one line in length by one inch and a half. The young broods appear at the end of May or the beginning of June. Coots are not in much request for the table, as may be supposed from the price, which is rarely above eighteen-pence a couple. The beak is of a pale rose red, the naked patch on the forehead being of a pure white, from which the name "bald" is given to them; iris crimson; a semicircular streak of white below the eye; the whole body covered with black feathers tinged with slate grey; primaries pure black; secondaries the same, but tipped with white, forming a narrow bar across the wing; legs, toes, and membranes dark green, with a ring of orange above the tarsal joint; length sixteen inches.

The above are common to our internal waters as well as our sea-coasts, but the following are almost confined to the latter, though a specimen may occasionally be met with some few miles inland, especially in severe winters.

The WILD SWAN or HOOPER (*Cygnus ferus*). Of this bird there are several varieties—the common wild swan, Bewick's swan, the Polish swan, and two small sub-varieties of the Bewick swan. This last swan resembles the common wild swan in the colour of the base of the upper mandible; but the Polish swan has this part of a pale yellow instead of the bright orange. The internal structure of the three is shown to differ by Mr. Yarrell, and therefore, though the

external difference is so slight, there can be but little doubt that they are distinct varieties of this bird. The adult swan is of a pure white, but the young birds, like those of the tame or mute swan, are grey in plumage. They breed in the Arctic Ocean, and only visit these shores in the winter season, when the colds of their summer residence are too severe for them. They are easily shot, till rendered wild and cunning by incessant firing at them. A charge of shot from an ordinary gun, if directed against the head or under the wing, will often kill them; but not even swan-shot will penetrate the feathers of the back and upper surface of the wings. They weigh from twelve to twenty pounds, and strike with such force of wing as to break the arm of a careless or ignorant person.

The COMMON WILD GOOSE (*Anser ferus*), generally called the GREY LAG, is more an inland bird than one frequenting the coast; but it can scarcely ever be shot on the feed, which is its only reason for seeking the interior. In Scotland it is often stalked among the lochs, which are accessible to the shooter from their bold and partially-wooded shores; but in the south nothing but the punt-gun has a chance with this wary bird. The flavour of a wild goose, when in good order, is most delicious, and is even superior, in the opinion of some gourmands, to that of the wild duck or teal. Formerly the grey lag used to breed in our fens and marshes, but such a thing is now unknown, and in some mild winters—such as that of 1858-9—not a goose is to be seen on any of our coasts. The beak is of a pink-flesh colour, with the horny nail at the point white, as in the tame goose; iris brown; legs, toes, and membranes dull flesh colour; the plumage resembles that of the tame goose. The adult male measures thirty-five inches in length, and the female thirty inches.

The BEAN GOOSE (*Anser segetum*) very rarely breeds in this country, the greater proportion of those which appear in September and October having migrated here from the north. It differs from the *grey lag* in having the nail, edges and base of the bill black, the middle portion being orange. The plumage also is darker. The legs and toes also are orange. In length and weight there is very little difference between the two kinds.

The **WHITE-FRONTED** or **LAUGHING GOOSE** (*Anser erythropus*), though not so numerous in this country as the bean goose, is yet a regular winter visitor. It has a bill somewhat like that of the grey lag, having the nail white; but the feet and legs are orange coloured, like those of the bean goose. The general plumage is very similar to that of the latter bird, with the exception of the breast, which is nearly white, with patches and broad bars of black. In length it is less than either, being only twenty-seven inches from tip to tail.

The **BERNICLE GOOSE** (*Bernicla leucopsis*) appears in large flocks in severe winters, especially on our western coasts. It is even more shy than the rest of its congeners, and is still smaller than the last—its length being twenty-five inches. The bill is black, a stripe of the same colour extending to the eye; the legs and toes are also black; the forehead, cheeks, and throat are white; top of the head, neck, and breast black; upper parts black and white; tail black; and all the under parts greyish-white, the vent being pure white.

The **BRENT GOOSE** (*Bernicla brenta*) is the smallest, and at the same time the most numerous, of the geese frequenting our coasts, in the bays and creeks of which it is to be found in large flocks whenever the winter is severe enough to draw it from the north. It is never known to breed in this country. Like the bernicle goose, it has a black beak, and also legs and toes of the same colour; the head, neck, and breast are black, with the exception of a small patch of white feathers tipped with black on each side of the neck; the plumage of the upper part of the body is brownish black, with more or less grey edging to each feather; wing feathers and tail black; tail coverts and vent white; belly slate grey, the feathers being edged with white; length twenty-one inches.

The following catalogue embraces the more common varieties of waterfowl which are likely to be met with by the sportsman on our coasts. For a more detailed description of these I must refer my readers to the pages of Yarrell, Bewick, and other writers on this branch of natural history.

The SHELDRAKE or BURROUGH DUCK (*Tadorna vulpanser*), and the RUDDY SHELDRAKE (*Casarka rutila*).

The BLACK SCOTER (*Oidemia nigra*), and the VELVET SCOTER (*Oidemia fusca*).

The SHOVELLER (*Spatula clypeata*).

The ELDER DUCK (*Somateria mollissima*).

The LONG-TAILED DUCK (*Harelda glacialis*).

The GADWALL (*Chaulelasmus strepera*).

The GOLDEN EYE (*Clangula glaucion*), of which the young is the MORILLON.

The HARLEQUIN DUCK (*Clangula histrionica*).

The SCAUP DUCK (*Fuligula marila*).

The TUFTED DUCK (*Fuligula cristata*).

The GARGANEY or SUMMER TEAL (*Pterocyanea circia*).

The DIVERS (*Colymbus glacialis*, *C. arcticus* and *C. septentrionalis*).

The CURLEW and WHIMBREL (*Numenius arquata* and *N. Phaeopus*).

In addition to the above list, almost every sea-bird which frequents our coasts is occasionally included within the deadly range of the punt-gun or shot from the shoulder at a long range, when the more coveted birds are not to be come at. However much the puntsman may mentally exclaim, "Dilly, dilly, dilly, come and be killed," those constantly tormented birds, which are the special objects of his desire, will not always be so accommodating; and, in spite of every manœuvre, they manage to escape. Among those which he is most apt to turn his attention to under these circumstances may be enumerated the Ringed Plover; Turnstone Sanderling; Oyster Catcher; Redshank, common and spotted; Little Stint; Dunlin, or Purre and Purple Sandpiper; the Oxbird, and the Dotterel; also, the Cormorant, Gannet, and Gulls. The Rockbirds, including the Guillemots, Auks, Puffins, and Razorbills, also sometimes attract the fatal aim; but they afford no sport, and can only gratify the desire for blood which is so strong in some breasts as to call for constant gratification. In juvenile gunners this may be excusable, though not to be encouraged; but among those who call themselves proficients, they may surely be left to enjoy life as long as nature will permit.

DUCK AND PUNT-GUNS.

In the shooting of game birds it is not considered sportsmanlike to use a larger bore than No. 12; but in the species of sport which we are now considering, the object is to get birds, never mind how; and, as a consequence, there is no limit to the bore, or to the charge which may be used, so that the sportsman is not knocked over by the recoil. For inland shooting, especially of "flappers," a common game-gun is sufficient; but for general winter shooting what is called a duck-gun must be chosen, it being capable, from its bore, of carrying a large charge, and of killing at greater distances than the game-gun—from its barrels being nearly a foot longer. Of course these increase the weight very considerably, and this point limits the two qualities above mentioned, according to the strength of the shooter. Few men are strong enough to carry a gun of more than twelve or fourteen pounds weight, and yet this is the lowest at which a duck-gun is fixed by Colonel Hawker. The following are his directions. The duck-gun "should weigh from 12 to 20lbs.; should have a substantial stock, such as a fancy workman would be ashamed of; it should be made so large at the breech, that neat gunmakers would laugh at it; the stock should rise well up to the eye, because you have not the power to lower your head when holding out a heavy weight; and, above all, the barrel should *lie level*, and *well up to the eye*, instead of being let down into the stock so as to pitch under the mark in quick firing. A duck-gun should have either no heel-plate at all, or one of a metal which will not rust after loading in a wet place. The advantage of a duck-gun is, that it will carry large shot more compactly, and may be fired with double or treble the charge for a piece of ordinary size. You are, therefore, enabled to use large shot with the same advantage that No. 7 may be fired from a double gun; by which means, at a large object, you may kill considerably farther, and, in a flock, many more birds at a shot. The recoil of a duck-gun can only be checked by weight of metal; and there are two ways to dispose of it: the one, by immense thickness, whereby the

gun may be short, portable, and easily managed; and the other, by increasing the length, by which you may kill farther, and take more accurate aim. The former was the plan of Mr. Joseph Manton, the latter that of the late Mr. D. Egg; and, in order to partake a little of both advantages, I should steer between the two, and have barrels never less than three feet eight inches, nor more than four feet four inches, unless I used a rest. For pond and river shooting these guns may be from 12 to 16lbs.; but more than that greatly fatigues the arm; and with a gun of this weight a good charge is carried a very considerable distance. A broad butt lessens the recoil, and a piece of sponge adapted to it will still further diminish that unpleasant feeling."

For marine shooting a punt-gun is employed, which is a small cannon, and cannot be shot without an apparatus to break the recoil. This is effected either by means of a rope, or a spiral spring—the latter being the invention of Colonel Hawker. A single gun for this purpose weighs from 60 to 80lbs., and a double as much as 120lbs. As, however, this kind of sport is a speciality in itself, I shall refer my readers to Colonel Hawker's book, which gives minute directions for all its details. It may be mentioned, however, that since the colonel's time a great improvement has been made in punt-guns, by the invention of the system of loading at the breech, which considerably facilitates the management of this otherwise unwieldy machine. One of the chief difficulties in the way of the puntsman consists in the necessity, under the old system, of running the gun in before loading, and also in the exposure of the person and ramrod to the view of the birds. This is done away with by the breech loader, which merely requires to be opened by one hand—the other, if necessary, using the paddle, and without altering the breech ropes at all. Hence a second shot is sometimes practicable at the same flock before it has got out of distance; but in any case much time is saved, and the operation of loading is conducted without anything likely to alarm the birds. Whether punt-guns made on this principle perform as well as muzzle loaders I do not pretend to say; but unless they are very inferior to them in strength of shooting, their manifest advantages already described

must make them entirely supersede the old plan. Their construction will be found in the chapter devoted to punt-guns, including muzzle loaders as well as breech loaders.

BEST DOG FOR WILDFOWL SHOOTING.

The small Newfoundland and the water-spaniel divide between them the favours of the wildfowl shooter, but the latter is generally preferred. In the second book the former is represented in the shape of the land-retriever, with a slight cross of the setter; and there will also be found an exact representation of the northern Irish water-spaniel and of the south-country dog as well, the latter being free from white. A considerable difference of opinion exists as to the dog most suited to wildfowl shooting; but there can be no hesitation in affirming that the following points are essential to success:— In the first place, he must be hardy in constitution, with a woolly undercoat impervious to wet, and good powers of swimming. Then he should be completely under command, not requiring more than a look or movement of the hand to tell him what to do. Thirdly, he should be free from white, so as to be as little visible as may be, a liver colour being better than a black. Fourthly, a good nose must be super-added, and he must be taught to retrieve without injuring a feather. When these good qualities are combined in any animal, the shooter should not be inquisitive about his breed, nor should he care about appearances, which are often extremely deceitful. If, however, a water-retriever is to be reared and broken, the Irish water-spaniel, or the English dog of that breed, should be chosen, or the cross with the Scotch terrier and pointer, as recommended by Mr. Colquhoun, and represented among the retrievers. The small Newfoundland is very generally used, but his colour and size are against him.

FLAPPER SHOOTING.

The young broods of the wild duck which are bred in this country are just fledged and barely able to fly about the end of July, earlier or later according to the season. The method of proceeding will depend upon the breeding ground,

which may be either the banks of a small brook or of a lake. If the former, a good spaniel or setter must be employed to search the banks, and push out the ducks, the old one being generally the first to show herself, but usually out of shot, unless her brood are unable to fly, when she will often sacrifice herself in trying to draw off attention from them. On lakes or large rivers a boat or punt must be used, in which the shooter proceeds to the reeds on the banks, or on any small islets where he suspects the ducks to harbour; then sending his dog quietly into them, he picks off the flappers as they make their appearance. They are easily shot, No. 6 being quite sufficiently large, and a common game-gun is the proper one for the purpose. As the individuals composing the brood generally get up pretty quickly one after the other, a breech loader will be found to be a great convenience. Young ducks, a little older than to be called flappers, are often met with in August and September on the small pools where dogs go for water, either in grouse or partridge shooting.

WINTER WILDFOWL SHOOTING ON INLAND WATERS.

From the watchful nature of all wildfowl, they demand the greatest possible caution in approaching them, and to get a shot at them requires almost as much preparation as at a red deer in the forest. The shooter, dressed in the quietest colours possible, and provided with his well-trained retriever, his telescope, and his heavy double-barrelled gun, which should carry two ounces of shot, proceeds first of all to make out, by means of his glass, the exact position of the flock he is about to stalk; or if this is impossible, from the nature of the water, he must approach the bank as quietly as possible, and as near as may be to the most probable feeding-grounds. When at last he sees the surface of the water, he must be prepared for a quick shot either at a group on it, or at single birds on the wing. From the constant windings of narrow rivers and small streams, and from the disturbance on large ones caused by the traffic, it is seldom that sitting shots can be obtained on them, and the shooter must be content with flying shots, which are usually long ones and

require a hard-hitting gun. On the lochs of Scotland, however, and the large inland waters of England, by careful stalking a flock may be approached, and the greater part of the two ounces of shot in each barrel may be brought into use. The art of stalking, however, is only to be learnt by practice, and no written description will be of much avail. The shooter may nevertheless, be cautioned to get to leeward of the fowl; for, though it is doubtful whether their sense of smell is very acute, there can be no question that the slightest noise puts them on their guard. As soon as the approach can no longer be concealed, let the shooter suddenly rise, when in all probability the ducks will dive instead of taking wing, and while they are under the water a run may be made towards them, which will probably bring them within shot when they come to the surface again. At this moment a snap shot will often succeed in killing one or two, but the gun must be ready and almost at the shoulder, or they will be down again before the trigger is pulled. If a sailing boat can be launched on the water it is by far the best means of approaching wildfowl, as they will lie to it when a punt would immediately disturb them. For this kind of sport the shot must be large, and No. 4 will probably suit the best on the average. As all wildfowl fly fast, the aim must be from a foot to two feet in front of them, or they will inevitably be missed. Ducks rise almost perpendicularly, and therefore the aim must also be raised as well as directed forwards. In shooting teal on rivers, good sport may often be obtained; as they do not take long flights like the ducks, but soon alight again on the same river or brook. They fly very fast, and take a good deal of shooting; but to a practised hand and eye they afford extremely good sport when they happen to frequent any river of which he has the control. In marking them down the eye should be kept well forward after the teal appears to drop, as this bird is very apt to skim along the surface of the water for a long distance before he really settles. It is necessary, therefore, to send a man below, keeping him at some little distance from the bank till the teal fly, when he should at once show himself and so stop them. Coots and water-hens are most difficult birds to catch on the wing, while they dive so quickly

that they can seldom be shot on the water, and if not killed dead they do not rise to the surface. The most likely method is to conceal yourself and send a man to hunt them out on the other side, when they will sometimes rise fearlessly and expose themselves to your shot.

DECOY-DUCK SHOOTING.

It is a very common practice in France, and occasionally also in this country, to entice wild ducks within reach of an ambushed gun by means of decoy ducks. A hut is first built and carefully concealed by bushes, &c., near a small piece of water, which must of course be within call of the haunts of the ducks. Then fastening down five or six decoy ducks near one another on the water, their incessant quacking calls down the wild birds, and as these alight on the water they are swept off by the guns in ambush. It is not a very dignified sport, nor can I understand how it can be considered as anything more than a business; but there is no accounting for tastes, and I therefore mention it here as one of the means of shooting wildfowl. Both ducks and teal answer to the call of the decoy duck, but widgeon refuse altogether.

MARINE WILDFOWL SHOOTING.

Until the example and writings of Colonel Hawker introduced this sport to public notice, it was almost entirely confined to those who sought wildfowl for the poulterers, and were actuated solely by the love of gain. Nor has this kind of shooting even since his time become general, the difficulties and hardships in it being sufficient to deter most men. In the work on "Shooting," which has made the name of Hawker universally known, the details are given at great length, not only of the mode of carrying out the sport, but also of the punt-guns, punts, mud-boards, &c., which are necessary for it. In the present day small yachts of six or eight tons are preferred by gentlemen to the punt, being more safe than those frail machines, and also being sufficiently roomy to carry a friend as well as the proprietor and a couple of men. Birds seem to bear the approach of a sailing boat much

better than a punt propelled by a paddle, which necessarily makes some slight noise, however carefully it may be used. Besides which, they have generally been accustomed to see sails without being injured by them, whereas the punt is never without its sting. The various modes of carrying out the shooting of wildfowl by means of the punt and punt-gun must, however, be studied in the pages of nature, with the assistance of Colonel Hawker as far as theory can be made available.

CHAPTER VI.

RIFLE SHOOTING.

OBJECTS FOR WHICH THE RIFLE IS USED—TARGET SHOOTING—ROOK SHOOTING—RABBIT SHOOTING—DEER STALKING.

OBJECTS FOR WHICH THE RIFLE IS USED.

THERE are two general purposes to which the rifle is adapted, the more important being the destruction of man by his fellows in war, while the subsidiary one is for amusement, either by means of target shooting, deer stalking, rook, or rabbit shooting. Where game is sought for in order to support life, as in the backwoods of America, the rifle comes into play as a necessary, but in this country it can scarcely ever be adopted excepting for purposes of sport or war; and as this book does not profess to treat of the latter, the limits of the tool are readily assigned. There is a great difference between the military rifle and that intended for sporting purposes, chiefly depending upon the range, which in the former must be as extensive as possible, while in the latter it is rarely required to extend beyond two or three hundred yards, and, indeed, few sporting rifles are sighted beyond this. For our island purposes a small ball is sufficient, but in India and Africa, where the elephant or the lion must be despatched by a crashing and immediately fatal injury to the brain or some other vital organ, nothing less than two or three ounces of lead is thought sufficient. Again, in the

military rifle it is thought a *sine quâ non* for the purpose of safety that the cartridges should not contain any detonating powder, because they may explode, when collected in masses, with a most disastrous result. But in the sporting rifle there is little or no danger of such an accident; and several very efficient breech-loading pieces are used with cartridges containing detonating powder. All this will, however, be fully described in alluding to each particular rifle.

TARGET SHOOTING with the rifle is a very common amusement in some countries, and in Switzerland it is quite a national pastime. Latterly it has been gradually becoming more popular in England, and it may now (1861) be said to have obtained a hold upon the people. In the army it is, of course, regularly practised as a part of the business of the profession; but what I am now alluding to is target shooting with the rifle as an amusement, conducted in the same way as modern archery. There is a Swiss club in London, whose members meet at regular intervals at the Hornsey Wood Tavern; but it is to the Volunteer Movement which has been so triumphantly carried through, that the general knowledge now possessed by the nation of the use of the rifle may be ascribed.

The TARGETS, whether for civil or military purposes, should be carefully backed by some dense substance impervious to balls, and no mere fence of planks should be relied on. A wall or a faggot pile will either of them suffice, but nothing less impervious will do. The height should depend upon the distance at which the shots are fired; but for two or three hundred yards, a height of twenty feet and a breadth of thirty will secure against accident, though I have seen even this missed; but then such an unpractised shot should not be allowed to display his ignorance at a longer distance than fifty yards, when he could not fail to effect a hit. In the middle of this large bulk an iron or brick target is placed six feet high, and for sporting purposes generally square or circular, with a bull's-eye in the centre, surrounded by rings, as in archery. In military shooting the target is six feet by two, and is marked off by perpendicular and transverse lines into small squares. The Swiss use lincn squares set in frames, each of which is marked

with a bull's-eye surrounded by three rings, which score in the same way as in archery. Another plan is to measure every shot in inches from the centre of the bull's-eye, and the average of the measures of the whole number shot by each person is called "the average string," while the sum of the lengths is "the total string." This is the best test for sporting rifles, because most of the objects which are likely to be shot at are of an irregularly square or circular form, and not like man, three squares of two feet each, placed one on the top of the other. Those therefore who like to practise target rifle shooting with the intention of becoming good game shots will do well to procure an iron target six feet in diameter, and back this with a wall or faggot pile about forty feet wide by twenty high, after which they may fire away and endeavour to make the best "string" they can. An average string of one inch at one hundred yards, and two inches at two hundred yards, is first-rate practice, and is seldom attained. Where expense is an object, and the screen must be reduced as much as possible in size, an archway is constructed at a distance of a few yards from the shooter, so that his balls cannot possibly escape the screen; for if they are directed outside it they are stopped by the arch. This is shown in the accompanying cut, in which *a* represents the rifle, which is directed to the upper edge of the screen *d*,

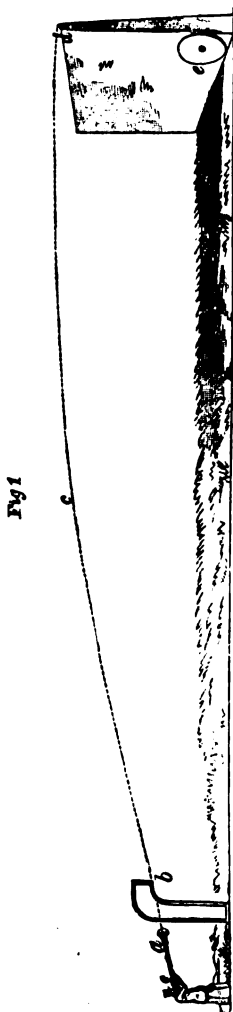

and passes through the trajectory *c*; but if it were held any higher, the ball, before it could pass in a higher line so as to rise above *d*, would be stopped by the arch *b*, which may be placed conveniently at the front of the loading-shed; *e* is the target. This plan is very commonly adopted in France.

ROOKS and RABBITS need scarcely be alluded to as *pabulum* for the rifle, each being too well known to need any description.

The STAG, or RED DEER (*Cervus elephas*), is the largest of the British deer, of which three varieties are known—viz., the red deer, the fallow deer, and the roebuck. The first is considerably the largest; and the following dimensions—given by Mr. Scrope in his interesting work on deer-stalking—will afford some idea of his enormous size:—

	ft. in.
Height at shoulder	3 11½
Girth at shoulder	4 7
Height from top of head to fore-foot	5 6
Length of antler	2 6
From top of antler to ground	7 10
Gross weight	308lbs.

In colour, the stag is usually of a reddish brown, with blackish muzzle, and mane mingled with grey; the inside of the thighs and flank being lighter, and approaching to a fawn colour. Deer under one year are called *calves*; till three, a male a *brocket*, and the female a *hearst*; at three, the male a *spire*, and the female a *hind*; at four, a *staggart*; at five, a *stag*; at six, a *warrantable stag*; and after this, a *hart*. The female does not breed till three years old, and has only one calf. The male is known from the female by having a pair of horns, which are shed yearly, and change in form with every succeeding year. Each fully-developed horn has a *brow*, *bay*, and *tray* antler, and *two points* also on the top. The three first are termed the *rights*; the two points, the *crockets*; the horn itself, the *beam*; the width, the *span*; and the rough part at the junction with the skull, the *pearls*. The age is known by the horns and by the slot. The BROCKET has only small projections, called

knobbers, with small *brow antlers*; the SPIRE, a *brow antler* and half-developed *beam*, called *uprights*; a STAGGART, *brow*, *tray*, and *uprights*; a STAG, *brow*, *bay*, and *tray*, with one horn *crocketed* and the other *single*; a WARRANTABLE STAG has *brow*, *bay*, and *tray antlers*, with *crockets* on both horns. After this no rule can be given, as the horns constantly vary in all points; but if they have three points, the harts are called *royal*. The slot is the proper name, according to the laws of *venerie*, for the tread of the deer, which in the hind is much narrower and longer than that of the stag, especially at the toe. In the warrantable stag the heel measures fully two inches; if more than this, and deeply indented into the ground, he is a large heavy old hart; and such usually bring up their hind feet to the impression made by their fore feet. The deer's haunt is called *his lair*; where he lies, *his harbour*; where he rolls, his *soiling-pool*; where he breaks through a fence, *his rack*; if he go to water, he *takes soil*; if headed back, he is *blanched*; if he lies down in water he is said to be *sinking himself*; an unwounded deer is called a *cold hart*. The red deer is rather a delicate animal, and bites close like a sheep, requiring an enormous range of pasturage to afford him such a choice and change as shall keep him in health. The hart ruts about the end of September, or beginning of October; and this period is exceedingly short, as compared with the sheep and goat, only lasting a single week. They show the change by a peculiar swelling of the neck, where they throw out a ruff of long hair; and at this time their flanks are tucked up, from their refusing food and their tendency to fret. While rutting they are very restless, and roll constantly in the peat mosses, becoming often perfectly black with the soil that adheres to them. They are now wholly unfit for human food, and are never sought after by the sportsman, who selects, in preference, the more backward harts and the hinds, which are then just coming into season, but seldom yet fat and of good flavour. The rutting harts are exceedingly pugnacious, and terrible battles are constantly taking place for the possession of the females, a whole harem of which are the spoil of the conqueror. The period of gesta-

tion in the hind is eight months; the fawn is left during the day concealed in the heather, and is only suckled at night. The suckling hind is poor and tasteless, and should be allowed to escape from the rifle-ball. Hinds which do not breed are called yeld-hinds. The direction of the deer's flight is almost always up-wind, in order to be forewarned, by their acute sense of smell, of any approaching danger. There is great difficulty in changing this instinctive course, but it may be done under certain circumstances. The hinds are always the most vigilant, and are set to give notice to the harts. The hinds are also always put first in the run, except in cases of great danger, when the master-hart comes forward and boldly faces it. The timidity of the red deer is very remarkable, and he can scarcely, except by compulsion, be induced to remain near the haunts of man. Every movement alarms him, from the cry of the plover to the flight of the hill-fox. He is more especially timid when he cannot make out the exact nature of the danger which threatens him; while, if he sees his great enemy—man, even comparatively close to him, he is much more composed, though still wary, and never confused or flurried. When pressed he stands at bay, and in this position is a very dangerous antagonist for both dog and man, as he will defend himself with horns and hoof till the last extremity. By choice he selects water if pursued by dogs, as his instinct tells him that in this element his superior size and length of leg will give him a great advantage. Here few dogs can pull him down, and when they attempt to reach him by swimming they soon fall victims to the sharp points of his formidable horns. The red deer in Great Britain are confined to the most retired and inaccessible parts of the Highlands of Scotland, to the Quantock Hills of Somersetshire, and to some of the adjacent ranges of Devonshire; but, in addition to these, may be mentioned the deer confined in certain parks, as Richmond Park, &c.; but these can only be considered as deer in confinement. In Scotland only are they stalked, being reserved for hunting in the west of England.

The ROEBUCK (*Capreolus caprea*) is also an inhabitant of some of the Scotch deer-forests; but it is chiefly confined to the wooded parts, not choosing the mountainous and open

situations like the red deer. In size it is not to be compared to its larger congener, being only twenty-four inches in height. This little deer is seldom stalked, however, being easily driven towards the spot where the shooters are posted. Buck-shot are more frequently used than the bullet; but in many cases the rifle is preferred.

The FALLOW DEER (*Dama vulgaris*) is only known in Great Britain as a denizen of our parks, where the individuals intended for the table are killed by the keeper with his rifle; but this can scarcely be considered sport, and it therefore will not be alluded to as such.

THE DEER-FORESTS OF SCOTLAND.

The following is a short summary of the deer-forests of Scotland according to Mr. Scrope, who is the chief authority in this matter:—

First, those of Sutherland, the chief of which are the Dirrie-Chat and Dirrie-Moss; the former being fifty miles long by an average of twenty miles wide, and the latter being about thirty miles by twenty. But, besides these, three smaller and detached forests are comprehended within this district—viz., the Parph, the Clibreck, and the Dirrie-Meanach. It is supposed that about 1500 red deer are at large in Sutherland.

Secondly, those comprised within Ross-shire are the Forests of Applecross and Gairloch, most of which are only adapted for the red deer, and are too wild and rugged even for sheep. Balnagown Forest is partly devoted to sheep, but red deer also are found here, and in Loch Broom, Castle-Leod, Novar, and Tulloch. The estate of Foulis is peculiarly adapted for the red deer, but is now too much frequented by the shepherd. Coigach, the property of Mr. Hay Mackenzie, is strictly preserved; and, in addition, the islands of Harris and Lewis are sure haunts of this noble specimen of the deer kind. At Coul, the property of Sir George Stuart Mackenzie, the red deer are very numerous, though it is only of late years that they have become so. Applecross is a celebrated forest, and contains large numbers of deer within its secure and sheltered corries and on its hill sides.

Thirdly, Inverness-shire contains the celebrated Glengarry Forest, which, from east to west, is about seven miles in extent; also, Glenfeshie, containing 13,704 Scotch acres, but now used as a sheep-walk. Gaick, consisting of 10,777 acres, strictly preserved by Sir Jos. Radcliffe; Drumachtar, comprehending 5,782 acres, now used as a deer-forest by the Marquis of Abercorn; Glenavon, containing 22,086 acres, and held by the Duke of Richmond as a deer-forest, in connexion with Glenbuiily and Glenfiddich, the former in the same shire, and containing 3,396 acres, the latter in Banff, and making up 5,522 acres: these all formerly belonged to the Duke of Gordon.

Fourthly, Aberdeenshire has within its limits Invercauld, eighteen miles in length by about three miles in width, and containing an enormous number of deer, though these fluctuate so much as to be difficult to calculate. They are generally very fine and large, mainly owing to the excellence of the feed in this district, and the strictness with which they are maintained in an undisturbed condition. The Forest of Mar is also in Aberdeen, closely butting upon Invercauld, and consists of the four following glens, viz, Glenquoich, Glenluie, Glendee, and Glenduildy. Its length is about fifteen miles, and its breadth eight; and it is supposed to hold 3000 deer. It is the property of the Earl of Fife.

Fifthly, Argyleshire contains the Forest of Corrichibah, in the district of Glenorchy, the property of the Marquis of Breadalbane, and holding at least 1500 deer. It extends over 35,000 acres, and the nature of the ground is such as to render it one of the best deer-forests in Scotland.

Sixthly, Perth has also its Forest of Glenartney, the property of Lord Willoughby d'Eresby, and containing 2800 acres, with from 700 to 1000 deer; but its crowning glory, as far as sport is concerned, may be considered to reside in the Forest of Athol, in which 51,708 imperial acres are devoted exclusively to the red deer, with the exception only of Glen Tilt, where sheep are sometimes admitted; 7000 deer are now supposed to be at large in Athol, but, at the lowest computation, there must be from 4000 to 6000. This noble property is strictly preserved by the Duke of Athol, and deer stalking is here carried to that degree of perfection which has been so well described by Mr. Scrope.

And *seventhly*, in the Hebrides, also, red deer are found, and chiefly in the islands of Jura, Mull, and Skye; but they are here in much less numbers than on the mainland: yet in Jura alone there are said to be 500, and in Skye about half that number.

THE DEER-HOUND.

The dog employed to pull down the wounded red deer is that known as the deer-hound, which resembles a large greyhound in shape, but is clothed with very coarse wiry hair, considerably longer than that of the smooth greyhound; the face is bearded with this hair like that of the Scotch terrier, or otter-hound, but there is no intermixture of wool as in the undercoats of those dogs, and the hair is of a coarser and more wiry character. The deer-hound hunts both by scent and view, abandoning the use of the nose when his game comes within the scope of his eye. The mode of using this dog is to hold him in slips, generally with a companion, till he is wanted, and then slipping him either in view of his game, or else being put on the scent, he follows it up as long and as well as his powers will allow. The true deer-hound is now extremely rare, most of those supposed to be of the breed being merely rough greyhounds. Indeed, it is very difficult to distinguish the one from the other, the only external mark being the carriage of the head in running, which is low in the greyhound and high in the deer-hound. A cross between the greyhound and foxhound has been tried, and found to answer well. According to Mr. Scrope, an infusion of bulldog blood, with the intention of giving courage, fails, because the produce follows the peculiar habit of this breed in attacking the stag in front, and is consequently impaled on his horns.

ACCESSORIES.

The telescope is quite as necessary for stalking as the rifle, and it should be of the very best make, especially in deer stalking, in order to detect the stag at a great distance, even if, as is often the case, his horns only are visible. A large field is incompatible with great power, and therefore the

stalker should content himself with what he *can* obtain. For many purposes the ordinary race-glass, the field of which is much more extensive than that of the compound telescope, is sufficiently strong, but for deer stalking it is quite inadequate. With regard to dress, all that can be said is, that it should be composed of such neutral colours as shall not easily be distinguished, and of materials which, while they afford protection from the weather, will permit the free use of the limbs.

THE SPORTING RIFLE.

As I have previously hinted, the form of rifle best suited to the sportsman altogether depends upon the particular kind of game which he is about to pursue. Thus, for rooks and rabbits, a very small bore is to be selected, such as is seen in what is called the "pea rifle," from the ball being of that size. For red deer, when a spherical ball is chosen, it should be at least sixteen to the pound, that is, suited to a 16 gauge. In a conical ball, the absolute weight in this case will be about double that of the spherical, for on the average two diameters and a half may be reckoned on. Hence a smaller bore than 16 is often used; any, from the Enfield rifle, the gauge of which is 24, down to Purdey's 40 bore, will serve, though perhaps hardly to be depended on, if a bone is to be broken. Again, in still larger beasts, such as the elephant, rhinoceros, or lion, the heaviest projectile which the shoulder can bear is the only one that should be trusted, the immediate death of the animal being necessary to the safety of the sportsman. As an instance of the time which a small ball takes to produce death, even if passing through a vital part, we may mention that it has been stated, on excellent authority, that a rebellious Sepoy was shot through the liver and stomach with three of Colt's pistol balls, as he was coming up to attack an officer near Delhi; yet in spite of these serious wounds, which would soon prove fatal, he was nearly able to overpower the sword of the Englishman, who, however, at length cut him down; and on examination the three balls were all found to have passed clean through him, and through the vital organs to which I have alluded. The same thing may, of course, happen with any of the lower animals,

showing the necessity of using a ball large enough to produce such a shock to the system as shall cause a sudden rather than a lingering death. All these elements must, therefore, be taken into consideration in discussing the question; and no one can give or form an opinion without previously deciding on them. So, also, with regard to the choice between muzzle-loading and breech-loading rifles, all must depend upon the degree of accuracy and strength of shooting which will be demanded. There can be no doubt that *per se* quickness of loading is an excellent quality; and many a chance is lost in the forest from the time taken up in loading the old-fashioned tool. But if the breech-loading rifle shoots with less accuracy and strength than the muzzle loader (of which I am very doubtful), it cannot compete with it where these latter qualities are of greater importance than the former. For our British rifle shooting I am undoubtedly of opinion that the breech-loader is sufficient in the above respects, and that it will be found a most serviceable article in the hands of a good shot. On the other hand, in shooting elephants, tigers, and other very large quadrupeds, it will be perhaps prudent to keep to the old arm; at all events, until it is demonstrated that recent improvements have effected a sufficient alteration in the qualities of the new one. I am here only indicating the *general principles* on which the selection of a rifle should be made, leaving the practical details to be filled up in the part which treats of the various kinds, their construction and management. (See Book V.)

ROOK SHOOTING.

When rooks are to be brought down by the rifle, most men content themselves with sitting shots, using this kind of gun as being more difficult than the shot-gun, and therefore more worthy of a sportsman's notice. Rook shooting with an ounce and a half of shot is certainly only suited to boys or more elderly tyros; but with the rifle, at from sixty to one hundred yards, so small a target as the body of this bird presents is not very easily hit, and I have seen a tolerably practised shot miss the same rook half-a-dozen times in succession. There are some men who bring down these

birds with unerring precision while wheeling round the nest on the wing, just as there are sportsmen who, not content with the difficulties of ordinary grouse shooting, use the rifle on the moors in lieu of the shot-gun; but these are the exceptions; and as there are very few Robin Hoods in the present day who with an arrow can bring down a goose when a quill is wanted, so these extraordinary rifle-shots are more frequently heard of than seen. It must be remembered that with these light balls the effect of the wind, if there is any, should be calculated on and allowed, as should also the difference of elevation in the sights when the shot is taken from a spot nearly exactly under the rook. Every rifle is sighted to allow for the fall which the ball makes when projected horizontally, and therefore it will be found that, if shot perpendicularly upwards, it will not hit the mark at which it is aimed, but the ball will pass on the side opposite to that faced by the shooter. The same applies to shot-guns, and those who use them at objects perpendicularly above their heads are very apt to be deceived. The force of gravity here only acts in reducing the length of range, and the consequent force with which the ball or shot is impelled, and when the passage of these is quite perpendicular it does not deflect them in the least. When, therefore, this kind of shot is taken, the aim must be such as to allow for this variation, and in proportion to the angle must be the allowance. In rook rifle-shooting at birds just fledged and barely able to fly, as is the case with those generally shot, they will often allow of a series of balls being fired at them, for the passage of the bullet makes very little impression upon them, and beyond the explosion below they find nothing to alarm them.

RABBIT SHOOTING.

The quickness with which these little animals evade the eye of the shooter when they are alarmed renders them extremely difficult to shoot with the rifle, excepting when they can be taken as sitting shots, which its superior range to that of the shot-gun will often permit. Rabbits seem to know from experience, either in their own persons or in

those of their papas and mammas, that beyond fifty or sixty yards they are tolerably secure ; but the moment the sportsman comes within that range they give a "hop, skip, and jump," and show their white scuts at the entrance to their holes. But when there is a spot which will enable the rifle shooter to get within one hundred yards of rabbits either on the feed or at play, they may often be picked off by a good marksman, but seldom more than a couple of shots can be obtained, as they are readily alarmed ; and even if they are missed, they retire to their holes till dark comes on and puts an end to the chance of shooting them on that occasion. Occasionally the hand and eye are so quick that a "snapshot" is successful ; but there are few sportsmen who can attain this extreme excellence in the art ; and I confess I have never seen the attempt successful, though I have known it tried by good shots. The rifle may be made of sufficient lightness to be easily and rapidly handled ; but it requires such a delicate adjustment of the eye to the sights to insure accuracy, that it is almost impossible to cover so quick an animal as the rabbit.

DEER STALKING.

Not having had any practical experience in this kind of rifle shooting, I can say nothing about it excepting at second-hand, and my readers must consult the pages of Mr. Scrope for full information on the subject. As, however, they may like to have an idea of what it is, I shall extract one or two passages from his most amusing and instructive book. The deer stalker should never attempt this kind of sport without being possessed of a strong, active, and hardy frame, together with nerves of iron and the patience of Job. For a "quiet shot," the last quality is the only requisite ; but few deer stalkers would consider themselves as worthy of the name who contented themselves with this imitation of battue shooting. There must also be an amount of training which requires some time for its performance, and as a consequence the denizens of our cities who run down to Scotland in the hope of acquiring laurels, are generally doomed to be disappointed. Not only is simple walking

and running required, but they must be practised at a high rate up hill and down in a half-stooping position as well as erect; and not unfrequently crawling on the ground for a long distance must be adopted, in order to reach a particular spot unseen by the deer. Now, these attitudes are very fatiguing if tried by the novice; yet unless they are practised, no horns will grace the hall. If the "gillies" or hillmen are to have the whole management, as is indeed most frequently the case, the stalker is a mere machine, and his bodily powers only will be called upon; but if he attempts to take any of the control upon himself, he must have considerable knowledge of the habits of the deer in order to circumvent them. He must be full of resources to meet wile with wile; and, as there are few more cunning animals than the red deer, his task will not be a very easy one. Indeed, unless he knows every inch of the ground, however well he may be acquainted with the nature of the sport elsewhere, he had better trust to those who do.

According to Mr. Scrope, there are three kinds of stalking practised, but these I think should rather be considered under two heads—viz., stalking and driving. He, however, enumerates quiet stalking, quick stalking, and driving; but the second of these is only a variety of driving. It is quite true that in quick stalking the sportsman makes an occasional run to get nearer the deer as they pass, but still the essential feature consists in the driving of the deer towards him while he is in concealment.

QUIET STALKING is thus described by Mr. Scrope:—Premising that the two stalkers (Mr. Scrope and his friend) are respectively alluded to as Tortoise and Lightfoot. The first of these gentlemen, attended by their gillies, has just discovered a hart at some distance, and thus addresses his friend and pupil:—

"A noble fellow he is, Maclaren; I can just see his horns and the point of his shoulders. It is a glorious chance, for, once in the burn, we can get within a hundred yards of him, and that is near enough in all conscience. Here, Lightfoot, look at the fine fellow; pull off your cap, and rest the glass on the stone."

"Not the semblance of a deer can I see; but I'll take your

word for it; I dare say he is there, since you say so. And now explain to me how you mean to get at him; communicate, my good fellow; for it seems, by all your caution, that even at this distance you dare not show a hair of your head."

"Creep back there behind the hill, whilst I mark the very spot in the burn which is opposite his lair. Well, now, I will tell you: we must go all round by the east, behind yon hill, and then come up at the notch behind yon two hills, which will bring us into the bog; we can then come forward up the burn, under cover of its bank, and pass from thence into the bog again by a side-wind, when we may take his broadside—and thus have at him; so let us make the best of our way. It would be quite easy to get at the hart, if it were not for the hinds on the top of the hill; but if we start them, and they go on belling, the hart will follow them whether he sees us or not. Get your wind; he cannot. Maclaren, you will remain here, and watch the deer when I have fired. Sandy, follow you at a proper distance with the dogs; and come you along with us, Peter, and take the rifles. And now, my lads, be canny."

The party then advanced, sometimes on their hands and knees, through the deep seams of the bog, and again right up the middle of the burn, winding their cautious course according to the inequalities of the ground. Occasionally the seams led in an adverse direction, and then they were obliged to retrace their steps. This stealthy progress continued some time, till at length they came to some greensward, where the ground was not so favourable. Here was a great difficulty; it seemed barely possible to pass this small piece of ground without discovery. Fraser, aware of this, crept back, and explored the bog in a parallel direction, working his way like a mole, while the others remained prostrate. Returning, all wet and bemired, his long, serious face indicated a failure. This dangerous passage, then, was to be attempted, since there was no better means of approach. Tortoise, in low whispers, again entreated the strictest caution. "Raise not a foot or a hand; let not a hair of your head be seen; but, as you value sport, imitate my motions precisely; everything depends upon this movement; this spot once passed successfully, we

are safe from the hinds." He then made a signal for Sandy to lie down with the dogs, and, placing himself flat on his stomach, began to worm his way close under the low ridge of the bog, imitated most correctly and beautifully by the rest of the party. The burn now came sheer up to intercept the passage, and formed a pool under the bank, running deep and drumly; the leader then turned his head round slightly, and, passing his hand along the grass as a signal for Light-foot to wreath himself alongside of him, said, "Now, my good fellow, no remedy—if you do not like a ducking, stay here; but if you do remain, pray lie like a flounder till the shot is fired. Have no curiosity, I beg and beseech you; and speak, as I do, in a low whisper."

"Pshaw! I can follow wherever you go, and in the same position too."

"Bravo! here goes, then; but if you love sport, do not make a splash in the water, but go in as quiet as a fish, and keep under the high bank, although it is deeper there—there is a great nicety in going in properly; that is the difficult point. I believe it must be head foremost; but we must take care to keep our heels down as we slide in, and not to wet the rifles. Hist! Peter, here, lay the rifles on the bank, and give them to me when I am in the burn."

Tortoise then worked half his body over the bank, and, stooping low, brought his hands upon a large granite stone in the burn, with his breast to the water, and drew the rest of his body after him as straight as he possibly could. He was then half immersed, and, getting close under the bank, took the rifles; the rest followed admirably; in fact, the water was not so deep as it appeared to be, being scarcely over the hips. They proceeded in this manner about twenty yards, when, the ground being more favourable, they were enabled to get on dry land.

"Do you think it will do?"

"Hush! hush! he has not seen us yet; and yonder is my mark; the deer lies opposite it to the south—he is almost within gunshot even now."

A sign was given to Fraser to come alongside, for they were arrived at the spot from which it was necessary to diverge into the moss. In breathless expectation they now

turned to the eastward, and crept forward through the bog, to enable them to come in upon the flank of the hart, who was lying with his head up-wind, and would thus present his broadside to the rifle when he started; whereas, if they had gone in straight behind him, his haunches would have been the only mark, and the shot would have been a disgraceful one. Now came the anxious moment. Everything hitherto had succeeded; much valuable time had been spent; they had gone forward in every possible position: their hands and knees buried in bogs, wreathing on their stomachs through the mire, or wading up the burns; and all this one brief moment might render futile, either by means of a single throb of the pulse in the act of firing, or a sudden rush of the deer, which would take him instantly out of sight. Tortoise raised his head slowly, but saw not the quarry. By degrees he raised himself an inch higher, but Peter plucked him suddenly by the arm and pointed. The tips of his horns alone were to be seen above the hole in the bog, no more. Fraser looked anxious; for well he knew that the first spring would take the deer out of sight. A moment's pause, when the sportsman held up his rifle steadily above the position of the hart's body; then making a slight ticking noise, up sprang the deer—as instantly the shot was fired, and crash went the ball right against his ribs, as he was making his rush. Sandy now ran forward with the dogs, but still as well concealed by the ground as he could manage.

“We must louse a dog, sir, or he will gang forrat to the hill.”

“Let go both of them; it will be a fine chance for the young dog; but get on a little first and put him on the scent, the deer is so low in the bog that he cannot see him.”

Fraser now went on with the hounds in the leash, sinking and recovering himself, and springing from the moss-bogs, till the dogs caught sight, and they were slipped; but the fine fellow was soon out of the bog, and went over the top of the Mealown. On following over the hill, the voice of the hounds broke full upon the stalkers, and they saw the magnificent creature standing on a narrow projecting ledge of rock within the cleft, and in the mid course of a mountain cataract; the upper fall plunged down behind him, and the water

coursing through his legs, dashed the spray and mist around him, and then, at one leap, went plump down to the abyss below; the rocks closed in upon his flanks, and there he stood, bidding defiance in his own mountain hold. Just at the edge of the precipice, and, as it seemed, on the very brink of eternity, the dogs were baying him furiously—one rush of the stag would have sent them down into the chasm; and, in their fury, they seemed wholly unconscious of their danger. All drew in their breath, and shuddered at the fatal chance that seemed momentarily about to take place. Of the two dogs at bay, Derig was the most fierce and persevering; the younger one had seen but little sport, and waited, at first, upon the motions of the older, nay, the better soldier. But his spirit being at length thoroughly roused, he fought at last fearlessly and independently. Whenever the deer turned his antlers aside to gore Tarff, Derig seized the moment to fly at his throat; but the motions of the hart were so rapid, that the hound was even compelled to draw back, which retrograde motion brought him frequently to the very verge of the precipice; and it was probable that, as he always fronted the enemy, he knew not, or, in the heat of the combat had forgotten, the danger of his situation. At this stage it was necessary to act speedily; and Tortoise having at length gained a spot which commanded a view of the stag, prepared to pour in a final shot. Three times the rifle was raised, but each time the aim was abandoned from fear of wounding the dog, or missing the deadly spot. At length an opening; the crack was heard faintly in the din of the waterfall—the ball passed through the back of the deer's head, and down he dropped on the spot without a struggle. The dogs now rushed forward and seized him by the throat, and were obliged to be choked off. The men came cautiously on, and began to lift the huge animal out of the water, two at his fore and the same number at his hind quarters. At last they laid him on the grass, then plunging the long knife into his throat, and opening him for the purpose of gralloching him, his head was bent back on his shoulders, a black flag was tied to his horns to scare away the ravens, a little gunpowder was shaken over him, and he was left to be sent for on the next day with the aid of the forester's pony. Such is the account

of stalking this animal in quiet style; let us now see the nature of the second mode adopted.

DOUBLE-QUICK STALKING and DRIVING are both of them dependent almost entirely upon the gillies, and the stalker himself has little to do with the sport except to keep quiet till the deer are in sight, and then to make a rush to get within shot, if the nature of the ground requires it. This constitutes what Mr. Scrope calls "stalking in double-quick time;" the term driving being by him confined to the case when the hillmen are able, in consequence of the peculiarity of the ground, to drive the deer within shot. In this latter species a large number of men are required, while one or two generally suffice for the former, their knowledge of the habits of the animal enabling them to induce him to take certain passes, without being absolutely forced to do so. This is effected by acting on the senses of smell and sight, which are very keen in the red deer. For instance, by posting the stalkers in a certain pass to leeward of the deer, and then taking a large circuit round them, the hillmen can, by very carefully giving the deer notice either by sight or scent that they are posted in the opposite direction, send them with great precision (when luck attends their efforts) towards the ambush prepared for them. There is, therefore, some difference, no doubt, and practically the two are conducted with details "wide as the poles asunder." In either kind of sport, however, it appears to me that the chief agents are the gillies, and that neither is to be compared with the quiet stalking previously described so graphically in the extract given above. Tastes differ, however, and for those who cannot bear the fatigue necessary for the first kind, the second and third are, no doubt, better suited.

In DEER STALKING of all kinds the heart is the organ aimed at, because, though no larger than the brain, and therefore quite as difficult to hit, yet a shot in many of the adjacent parts is likely, by the aid of the deer-hound, to result in the death of the stag. For instance, a broken leg, arm, or shoulder, or a wound of the lung, will put a stop to the flight of the animal, and the deer-hounds being slipt, soon bring him to bay. On the other hand, if the ball misses the brain, the deer goes away as well as ever, even if

the ball has lodged in the face or in the muscles of the neck. It is usual to aim a little behind the elbow in a quiet shot ; but if the deer is going at any pace, a foot in front of this part will only compensate for it. With these slight indications of what is necessary for deer stalking, I must close the subject, repeating that my want of personal experience does not allow of further details.





ENGLISH AND SPANISH POINTERS.

BOOK II.

THE ANIMALS USED BY THE SHOOTER, AND THEIR MANAGEMENT IN THE KENNEL AND THE FIELD.

CHAPTER I.

POINTERS AND SETTERS.

POINTERS (SPANISH AND ENGLISH)—SETTERS (ENGLISH, IRISH, AND RUSSIAN)—INTRODUCTORY REMARKS ON BREAKING—PREPARATORY EDUCATION—BREAKING AT PAIRING TIME—AUTUMNAL BREAKING TO THE GUN—REMEDIES FOR FAULTS.

POINTERS (SPANISH AND ENGLISH).

IN this country there are several varieties of the pointer still tolerably distinct from each other, but all running the one into the other so as to make the divisions far from distinct. Of these varieties, the old Spanish dog, now very rare, the heavy English pointer, and the light English dog, may be taken as the three types, as exhibited on the opposite page. *The old Spanish pointer* is now very seldom met with, but he is undoubtedly the original of all the existing breeds. The Spanish dog is generally considered to be descended from the hound, one of which is supposed to have shown a disposition to point, and this faculty being encouraged and "bred to," in time there has been produced the peculiar animal which is now so common. No dog is gifted with a more keen sense of smell, and in none is the development of the cavities of the nose more marked. He has also a large brain, and shows great intelligence and docility, as well as high scenting powers. It is from the extraordinary condition of the nervous system that he becomes rigid when excited by the scent of game; and though this state may be

imitated to some extent in other breeds, yet in none is it so clear as in this, resembling in the highly-bred pointer the disease known by the name of catalepsy. But, coupled with this large brain and broad nose, is a heavy and unwieldy body, which is soon tired by work, and thus this kind of dog can only be used for three or four hours at a time.

The modern English pointer is the result of a cross of the Spanish dog with the greyhound or foxhound, by which the delicacy of the nerves of the nose, and of the other parts of the nervous system, is to a certain extent diminished, while the body is rendered much more light and elegant. In proportion to the amount of Spanish blood in any breed is the size of the head, while according to the number of crosses from the greyhound or foxhound is the body made light, strong, and active. The former of these is the better of the two for the purpose of crossing with the Spanish pointer, because he gives all the advantages of the foxhound without the disadvantage of the tendency to stoop in hunting and to chase "fur." As the foxhound is crossed with the greyhound for the same purpose—that is, to give speed and endurance, the latter is in either case the real source of these qualities, and for this reason there is little doubt as to the desirability of choosing him in preference to his descendant, the foxhound. It is said that some breeds, though light and active, are descended from the pure-bred Spanish pointer by choosing out the lightest puppies to continue the breed; but I fully believe that none are free from one or other of the strains above mentioned, excepting those which show a certain degree of heaviness about the shoulders and disproportion between the hind and fore quarters, which is not by any means desirable. This, however, is purely conjectural, as there are few pedigrees which can be traced back for many generations. The late Mr. Edge's breed is said to be so descended, and probably it can be carried back as far as any other; but even his is lost in obscurity, and cannot be proved to be pure any more than those of Lord Derby or Lord Sefton.

The *points* which are looked for in the modern English pointer, whether of the heavy or light breed, are as follows: Head wide rather than long, flat at the top, with a forehead



ENGLISH, IRISH, AND RUSSIAN SETTERS.

descending abruptly to the eyes. These should be of middle size, but soft and intelligent-looking; muzzle square, broad, and deep, with flews, but not pendent; ears thin and soft, tolerably long, and set on low and forward, so as to be close to the cheeks; neck of good length, round, and free from dewlap—that is, not “throaty;” body of good length, but well ribbed up, and the back ribs deep, while the whole chest is round and barrel-like; loin strong and deep; shoulders slanting, and the blades long, reaching well up above the spine; elbows low, and neither in nor out; fore legs straight and long, not set back at the knees, with good round feet, not spreading, and *having thick soles*; hind legs well bent at the stifles, full of muscle, and with strong bony hocks; tail thick at the root, but at once becoming fine and tapering off to a sharp point. It should be quite free from curve, and should be lashed against the sides in working. Colour—black, liver, lemon, or black and tan, variously mixed with white. The self colours look very handsome, but are not sufficiently visible in the field, and generally white dogs with coloured heads, and a spot or two on the body, are preferred, especially if clearly marked with the colour in the mode called “ticked.”

SETTERS (ENGLISH, IRISH, AND RUSSIAN).

Setters are classed of three sorts—the English, the Irish, and the Russian. The two first of these are very much alike, but the true Irish being invariably of a rich red colour, are easily known from all but English dogs of a similar shade. In other respects they differ only in being somewhat longer on the leg, and straighter as well as longer and finer in the muzzle; but I believe that many reputed English setters of a red colour are descended from Irish ancestors, all being most probably derived from the spaniel.

The *English Setter* now generally stands when pointing, in which act he closely resembles the pointer; but before the invention of the flint-gun, he was taught to set or crouch, to allow of the net being drawn over him, that being the only mode of taking winged game then known; but as the method of shooting flying became general, he was gradually bred to stand as high as the pointer, and in the present day there is

little difference in the attitudes of the two. The setter is more light and airy than the pointer, and generally works at a faster pace, but there are some strains of the latter which will beat a field out quite as soon. There can be no doubt, however, that he bears cold and wet better than his smooth rival, and for work on marshes he is superior, while his feet and legs being more clothed with hair, he is also better able to stand the friction of heather. Hence he is generally preferred for snipe shooting, and for the moors wherever a setter can be met with possessing a good nose and steady withal, he is selected as the best dog for that kind of work. Generally, however, he yields to the pointer in these qualities; and unfortunately, although he may appear to be thoroughly broken to-day, yet next week he will show a want of steadiness which is most provoking. The latter defect is not so common now as formerly, nor is it so general amongst high-bred English setters, as among those in this country which are of inferior strains, or especially among Irish dogs, which are peculiarly headstrong, though possessed of great powers of endurance, and of delicate noses. There is seldom a want of speed in this dog, and more frequently he is too fast rather than too slow.

In general appearance there is little difference between the English and Irish setter, but by a good and careful observer the one may readily be distinguished from the other. Still, the difference is so slight that it is difficult to describe it; and with the exception of the rich red colour of the Irish dog, which is not often met with in those of pure English blood, the superficial observer would fail to detect any prominent point by which he might distinguish them. The head of each is of medium heaviness, between that of the true old pointer and the foxhound, but still showing the square muzzle of the former to a certain extent. The eye is brighter than that of the pointer, showing a degree of merriment seldom seen in that dog; ear long, thin, and clothed with wavy hair; neck longer and straighter than that of the pointer, and without the roundness of the nape peculiar to that dog; ribs flatter, and loin seldom so strong, there being a great tendency to slackness like that of the Newfoundland; hips ragged; shoulders generally loose and

oblique, with the elbows well let down; legs straight and well feathered; feet round, and soles strong, with a good deal of hair between the toes; hind quarter scarcely so muscular as in the pointer, but the stifles are well bent, and the hinder parts well feathered, like the fore legs; stern or flag long, and clothed with a brush of hair, which should come to a point, and resemble altogether a pointed sword, slightly curved upwards. If the hair stands out sideways in a bushy form, or if the tail itself is curled over the back, it is a sign of a cross with the Newfoundland or sheep dog. The colour of the Irish dog is always a rich red, slightly approaching to mahogany colour on the head, down the back, and along the flag. The English dog may be black, or black and tan, or liver-coloured, or yellow, or lemon, or red, or any of these mixed with white. The Duke of Gordon breed is much admired, being black and white, with tan on the cheeks and eyebrows, and also spotted down the legs. The coat should not be too thick or curly; as it is apt in that case to heat the dog too much, and render him incapable of working without access to water. The English and Irish setters are represented in the annexed engraving.

The *Russian Setter*, which is also exhibited in the illustration accompanying this article, is similar in shape to his English congener, but being clothed in a much more woolly coat, very long over the eyes and nose, his exact form can scarcely be recognised. Still, in spite of this apparent drawback, I have known these dogs stand heat almost as well as the English dog. Some years ago there was an opinion prevalent among sportsmen, that the Russian dog was endowed with a better nose than either of our indigenous varieties, and many of them were imported and used by good sportsmen; but experience has shown that there is no foundation for this opinion, and at present the breed is extremely rare. From the great length of their hair, they are very difficult to keep clean, and become liable to mange and surfeit if they are at all mismanaged. The engraving represents the peculiarities of this dog very well, and it is scarcely necessary to describe them more minutely. Generally their feet look too flat, but their soles are thick, and they stand work as well as any other kind of dog.

Both in pointers and setters the bitch is lighter in frame than the dog, and she is generally more quick and active. Her nose is somewhat more sensitive; and when she can be brought out well, she is very valuable in the field. This, however, is often very difficult, either from weakness in consequence of having reared a litter of puppies, or from disordered health arising from having been "put by." Of the two evils the former is the least, as the bitch recovers her strength, and with it her flesh, in an incredibly short space of time, if she is not absolutely diseased from mismanagement. I have known a litter of puppies whelped in July and suckled up to the last week in August; yet the bitch has been in high health on the 1st of September, and has gone through the month with great credit as to all the points essential to a partridge dog. On the other hand, many a bitch "put by" in June is not in condition for work till after Christmas, when her services are no longer required. On the whole, therefore, I should always advise that a bitch intended for work should be allowed to have a litter if she is likely to whelp before the middle of July.

INTRODUCTORY REMARKS ON THE BREAKING OF POINTERS AND SETTERS.

The proper education of all animals depends upon the consistent carrying out of two principles—viz., the hope of reward and the fear of punishment. The former is required to induce the pupil to do right, while the latter prevents him from doing wrong. Compulsion alone will never succeed; and the proverb that "one man can take a horse to water, but forty cannot make him drink," is perfectly true, and should be remembered by all those who undertake the training of any animal. By severity a dog may be kept in such subjection that he will never do wrong; but when broken in this way his spirit is altogether cowed, and he refuses to do the work for which alone he is wanted by his master. It is from the neglect of this knowledge that so many dogs are rendered useless, being "gun-shy," or "slack workers," or "blinkers;" all faults which make them quite useless in the field. Indeed, if a dog is brought up by the person who is

to break him, little or no severity will ever be required, the puppy learning from the first by experience that he must do what his master tells him, and never acquiring the habit of disobedience, which alone requires the whip. Great caution is necessary in those cases where a dog is committed to the charge of the breaker full of faults, and totally unaccustomed to control. Such an animal, if of a breed endued with high courage, may possibly become a first-rate dog; but without this quality the constant necessity for punishment will be almost sure to break his spirit, especially if the person who undertakes his education does not possess a good temper himself. The breaker of a pointer ought in all cases to be possessed of this quality; but it is not nearly so necessary when he has reared the puppy, and has thus been able to obtain his affections before commencing the actual breaking to the gun. Few gentlemen like to go through the task themselves, and there are not many who have the time for it; but if they can and will take the trouble to break their own dogs, they will be rewarded by having them of double value. There are many who do not care to work them in person, and depute the task to the keepers when they are on the moors or in the stubbles, and of course in such cases the latter are the proper persons to break as well as work the dogs. But if the shooter takes a pleasure in seeing the instinct of the animal displayed, and in directly superintending its operations, he must at all events make his dogs own him as their master before the season commences. A few days' exercising will do much, but nothing short of taking them into the field, and making them beat their ground, will insure the proper execution of their duties when the 12th of August or the 1st of September arrives. In old dogs it is often a long time before they will obey a new master, and many a first-rate animal is rejected on that account. One of the best and most thoroughly broken pointers I ever knew, after his second season, was sold, and although his purchaser took him out for several days to exercise, and fed him regularly, it was a fortnight before he would work. Indeed, the dog was so utterly regardless of him that he thought deafness only could account for it; but gradually he took to the work, and when he found that game

was killed to him, he became as attached to his new owner as he had previously been to his breeder, and never required the slightest encouragement afterwards.

PREPARATORY EDUCATION.

Implicit obedience is to be instilled from the earliest period, and a habit of self-control must be encouraged at the same time. Unless the latter faculty is in existence, there will be no steadiness; for though fear will keep down for a few seconds the desire to do wrong, yet the natural passion for the chase of game will overcome it, and a serious fault will be committed. Many sportsmen consider it unnecessary to interfere at all until the dog is taken into the field, but animals neglected in this way rarely become steady, at all events until their third or fourth seasons. It is quite true that an excessive degree of compulsion sometimes breaks the young pointer's spirit; and then, on taking him out, he cannot be induced to range at all, but slinks behind his master's or breaker's heel. This result is most unsatisfactory, and the fault is very difficult to eradicate; but it follows upon the abuse, and not the use, of proper means for keeping the young puppy in order. When the education is begun in proper time, harshness is never required, and, as a consequence, there is no cowering of the spirit, and no shyness of any kind. The dog may easily be made obedient, and yet full of spirit; and this is every day shown among those which are merely used as companions to man. Still, it is quite true that hundreds are spoiled every year by being broken at too young an age, and therefore it is better for the inexperienced owner to err on the side of delay, rather than risk the unfortunate result to which I have alluded. Much must always depend upon the degree of courage in the individual, for some dogs will bear without injury an amount of punishment and restraint which would ruin others. The breaker should always remember that it is much easier to take the courage out of a dog than to put it into him; and that in almost all cases, by patience and perseverance, with proper means, the most unruly animal may be made subservient to man.

The following comprise the points in which the dog should be made obedient to the word of command before he is taken into the field to show him game:

- 1st. To come to heel; the word being "Heel."
- 2nd. To run forward; "Hie on," or "Hold up."
- 3rd. To crouch on the ground; "Down."
- 4th. To drop at the sound of the gun; "Down charge."
- 5th. To avoid passing through a fence; "Ware fence."
- 6th. To refrain from chasing poultry, &c.; "Ware chase."
- 7th. To stop still; "Toho."

All these may readily be taught in the course of exercise, but they require some time to make the pupil perfect, and no one should expect to obtain success without an outlay of time and temper. The 1st, 2nd, 5th, and 6th are all most essential to the ordinary management of dogs at exercise; and without obedience in such matters, a lot of dogs would become totally unmanageable. But the master must remember that a half-obedience is of little use; the dog must be so taught that if once he is ordered to "heel," he will remain there until ordered forward by "hie on." Indeed, it is only by firmness in carrying out orders of this kind, which are easily obeyed, that subsequent commands of a more difficult kind are rendered capable of being enforced. The 3rd order, in its simplest form, is of nearly as easy a kind to carry out as the two first; for the dog may be forced down mechanically by the hand or foot, if he is at all inclined to rebel; but it is necessary to make the pointer crouch at the word "down," or at the raising of the hand, whatever the distance may be at which he is from his master at the moment; and this is one of the most important and difficult elementary arts in his education. By first making the dog crouch readily at his master's feet when ordered so to do, the habit is engendered; and then, if he refuses to do so at a few yards off, walk to him, make him drop and remain down while you move to your original position. If he is obedient, reward him with a piece of any favourite food; while, on the contrary, if necessary, he must be punished by a blow or pulling his ear. It is astonishing, however, to see the degree of implicit obedience that may be instilled with-

out any severe thrashings, the amount of which is generally in proportion to the ignorance of the breaker. I am now alluding to those cases in which the latter has had the management of the puppy from the earliest period; for it cannot be denied that if a high-couraged dog is sent to the breaker at twelve months old, and without any preparatory education, he must use the whip pretty severely at times. When the pupil is steady in dropping to the voice or the hand, make him do the same at the sound of a pistol, discharging it, and at the same moment raising the hand, or, if that is not enough, crying "Down." Great care is necessary at this stage to avoid severity, for many a dog is made "gun-shy" by being thrashed for neglecting to drop at the report of the pistol. When he first hears it let him be rewarded by a piece of food, and do not attempt to make him drop until he has quite got over the fear which naturally attends upon an explosion. By firing off the pistol, however, with a small charge at first, or with a cap only, puppies soon become regardless of the noise, and then they may be made to drop whenever they hear it. This part of the education should be made very complete before the puppy has game killed to him, or there will be great trouble in preventing him from "running in" and mouthing it.

The 5th and 6th words of command hardly require any comment, since they are only used when the dog is about to do wrong, and the tone of voice in which they are uttered is of that scolding or "rating" nature, that he readily understands that he must stop, or that he will be punished. An expressive voice is an essential to success in dog management, and the breaker of pointers and setters will hardly be likely to succeed well unless he has it to some considerable extent. It is wonderful what power this has over the dog, and how soon some men thereby obtain the affection and implicit obedience of animals which have refused altogether to become attached to others.

Lastly comes the 7th command, which is hardly necessary in a dog of high breeding, inasmuch as it is only intended to render more easy that which comes without effort to him as an instinct derived from his parentage. Nevertheless, it is just as easy to enforce as the first six; and as even the

highest-bred dogs do not always "back" as well as "stand" as soon as they are taken out, it is better to teach it with the other words of command. It is enforced as follows, and it may be efficiently carried out in kennel, or in the dwelling-house of the master. There is one great advantage attending it—namely, that it encourages a habit of self-control; and I have no doubt that dogs educated in this way are far steadier than others. But to proceed; the dog should have a collar on, to which is attached a cord, held by his master; then throwing down a piece of meat on the ground, he is restrained from it, and the word "Toho" at the same time is uttered in a stern voice by the master. In a short time the cord may be dispensed with occasionally; and if the dog neglects the word "Toho!" put it on again, adding a check-collar if he is at all inclined to be disobedient. The plan should be persevered in until the puppy is so obedient that he can be restrained from approaching his food at all times without the cord; but he should not be so cowed as to slink away, the object being to make him stop, but not leave the position in which he was when the word "Toho" was uttered. Hence the punishment must not be severe, and there must be no more fear felt than is sufficient to procure obedience.

As soon as these several habits are instilled, and the dog readily obeys the seven words of command, he may be taken out and shown game, and if well bred he will be readily broken. Colonel Hutchinson advocates a much more complicated preparatory education than this; and, among other things, he raises the right arm to the dog to enforce "Toho!" and the left to compel him "down." He also finds that he can educate a puppy to hunt high, by making him understand the word "Up," by means of food placed in a high situation indoors; but I confess that I cannot see the use of such complicated means to enforce comparatively simple ends. Consider the time that must be employed in teaching the difference between the right hand and the left; for even the hayband which is said to be necessary to the raw recruit to enable him to distinguish his right leg from his left would here fail to be of any assistance. I fully admit that a clever dog *may* be taught any of the arts recommended by Colonel

Hutchinson, but at the same time I contend that one quarter of the time spent in teaching any one of them would suffice to inculcate the subsequent performance to which this one was meant to be preparatory. If, then, this is true, the plan fails altogether; but nothing short of actual experience can demonstrate the truth or fallacy of his directions. I have never yet heard of his more minute instructions being carried out by any practical man; and as I know that the dog may be rendered perfectly complete in his education without them, I must continue to think that they are unnecessary, until I am shown to the contrary. I am quite satisfied, that if the seven points which I have described are carefully instilled before taking a dog into the field to show him game, there will be very little to do when there; the only respect in which no preparatory teaching will be of any service being in the method of beating his ground, which will be alluded to in the next stage.

BREAKING AT PAIRING TIME WITHOUT THE GUN.

In the month of March and early in April, partridges and grouse have paired, and are so tame, that they will lie like stones. At this time, also, the wheat is high enough to conceal them, while the weather being cool and the ground damp, the scent is so good as to enable the dog to find his game without difficulty. This, therefore, is the time to be chosen for commencing the education in the field of the pointer and setter. Premising that the pupil is under good command, and that he will readily carry out the seven orders which are specified under the article on Preparatory Education, the next points to be taught are—

1st. The range; that is, the method of beating the ground so as to avoid missing game.

2nd. The point; that is, the art of standing steadily the moment that the scent of game is felt with certainty.

3rd. To back; in which the dog stops in a more or less excited attitude the moment he sees another dog point or back.

4th. To draw; that is, when he feels a scent, but is uncertain about it, or is led to believe that game is moving

away, to approach in such a careful manner as to lead the sportsman in the right direction without disturbing the game.

Besides these four chief points which are now to be taught, the seven preliminary lessons will also have to be repeated day by day and hour by hour. If they have been neglected, they must be taught at the same time; but the task is thereby increased tenfold, and dogs which are not obedient to nearly all these words of command before they are shown game, rarely become steady at any subsequent period. It is a disputed point whether puppies should be broken to game at all without the gun, and Colonel Hutchinson decides in favour of postponing the education in this department till the autumn. He says:—

“I cannot believe it is the best way to attain great excellence, though the plan has many followers; it does not cultivate the intelligence of his” (the keeper’s) “pupils, nor enlarge their ideas by making them sensible of the object for which such pains are taken in hunting them. Moreover, their natural ardour (a feeling that it should be his aim rather to increase than weaken) is more or less damped by having often to stand at game before they can be rewarded for their exertions by having it killed to them; it prevents rather than imparts the zeal and perseverance for which Irish dogs are so remarkable. Particularly ought a breaker whose pupil is of a nervous temperament, or of too gentle a disposition, to consider well that the want of all recompence for finding paired birds must make a timid dog far more likely to become a ‘blinker’ when he is checked for not pointing them, than when he is checked for not pointing birds which his own impetuosity alone deprives him of every chance of impetuously ‘touseling.’ The very fact that the birds lie will frequently lead to mischief; for if the instructor be not very watchful, there is a fear that his youngsters may succeed in getting too close to their game before he forces them to come to a stand point.”

Now, this is all very pretty in theory, but practically I believe it to be utterly fallacious. In the first place, the chief difficulty always is in getting the dog to begin to point; for after he has once shown the disposition, the subsequent progress is a matter of patience and firmness on the part of

the breaker. Then granting this, how can the dog be benefited up to this time by the killing of game to his point, when he has not yet arrived at that stage? No one would attempt to work dogs unnecessarily at pairing time, but I do contend that a great deal may be done then far better than can be effected in September, and that if the breaking is put off altogether till that month, nearly the whole season will be wasted in "making" the dog. On the other hand, I have had dogs which, in the previous spring, had been made as perfect as possible without the gun, and which only required one day, or at the utmost two, in September, to complete them. I do not mean to say that subsequent experience did not improve them, but I assert that they were on the third of the month very much more steady and trustworthy than any dog I ever saw at the end of September, whose education had been deferred till the first of that month. There is another reason why spring teaching is to be preferred to autumn: the keeper or master has then no other object, and his temper is not liable to be ruffled by want of success in finding game or in killing it. He is not tempted to sacrifice his dogs to his "bag," or to blame them for faults for which he or his friends are really responsible. Again, there are few days in September when the scent is good; either the ground is dry and the air hot, or rain has recently fallen, and the steam produced by it interferes with the scent. Such a state of things as is likely to exist in this month demands the experience and caution of the old dog, rather than that of the untried puppy; and even if the young dog has been well drilled in the spring, and has come out with flying colours then, he will often have enough to do to make out his game. There are other reasons against following the colonel's advice, not the least of which is that the dog is rendered useless for the whole of one season; for no one can do much during that period with an animal which has never seen game till its commencement. I am an advocate for every sportsman breaking his own dogs, but I should certainly not recommend his doing so to the loss of his sport, and yet this must be the result if the practice which I am now disputing is adopted. For these several reasons, therefore, I protest against the postponement till the autumn of what may well be done in the spring. It is quite true that a dog steady

enough then will become so excited when he sees game killed, that he will run riot for a short time; but he *knows what is right*, and it is only necessary to correct his faults. There is little to be instilled into him, which is the most difficult part of all education, and after an hour's work he will settle down into a useful assistant.

The RANGE is the first of these four acts of education, and it is at once the most easy to teach to a certain extent, and the most difficult to teach fully. Almost any dog with good breeding, and unspoilt by confinement or the whip, will start off and keep galloping about in a meaningless manner; and this is sometimes called "beating;" but it is very wide of what is meant by the real sportsman when he says that his dog beats his ground in a proper way. Ranging should be so carried out that every portion of the field or moor is crossed by the dog nearly at right angles to the wind, and at the smallest possible distance from the shooter consistent with the act itself. The dog has already been taught to run forward at the words "Hie on" or "Hold up," but he must now be shown how to proceed in the best manner to find his game. Some dogs, from not being thus taught, are apt to run straight into the middle of the field, and when they find a covey there, as they often do, it is supposed to be by a kind of special instinct. But if the sportsman desires that his ground, either in a manor or on a moor, should be thoroughly and effectively beaten, he will direct his dog to begin to leeward, and then crossing from side to side nearly at right angles with the wind, but with a slight tendency forwards, the ground is ultimately all crossed and re-crossed with intervals of from fifty to a hundred yards, according to circumstances. In doing this, the wind blows the scent of the game sideways on the dog, and a good one will always be observed to carry his head obliquely in the wind's eye, as he crosses his ground; but the angle is in any case such that the scent is perceived just as well as if it was blown directly in front of him. If the dog is shy, he will perhaps refuse to beat, and then an older companion must be made to show him the way, which most puppies have enough of the faculty of imitation to be led to follow. Then for a time let both start off, the young one playing around his older leader, and without any idea of what

he is about. Presently the old dog "finds," and stands steadily, while the puppy looks like a fool for a short time; then his curiosity being excited, he tries forward, puts up the birds, and has a good chase after them. Encouraged by the scent and chase, and stimulated also by example, he soon begins to work on his own account, and as soon as he will do so, withdraw the old dog, and let the young one beat by himself. Never mind his chasing birds, hares, or any other game—let him enjoy himself and get a zest for the sport, for without this he will never be worth a farthing. Well-bred pointers become sufficiently excited in the spring without the gun, if they are not checked, and it is only by mismanagement that they can be made "blinkers." The moment they begin to work in earnest, whistle, and by that means attract their attention, then make them work to the hand—that is right or left, forward or towards you, according as the hand is waved in either of those directions. Some time and patience will be spent in carrying out this lesson, but it is all important, and upon it is based the whole system of ranging. Nothing else is to be attempted till the dog is tolerably perfect in this lesson—that is, till he understands what he has to do, though he may not always be willing to do it. Perfection in it will require a long time, but two or three days will generally effect what is now wanted. The young dog should always be "hied on" from the leeward side, so as to give him the wind, and then waving him to the right (or left, as the case may be), he is allowed to work on for a certain distance, which in enclosed districts is bounded by the nearest hedge, or in open ones ends at two or three hundred yards from the shooter. Here he is stopped by a whistle, waved forward for a few yards, then whistled again, and waved to the left, in which direction he proceeds till he has arrived at a similar point on the other side of the shooter, when the operation is repeated, but in the reverse order, and so the ground is beaten out. When two dogs are used together, one is started off to the right and the other to the left, and each being turned at equal distances from the shooter, and moved in opposite directions, they ought as nearly as possible to cross each time in front of him as he walks forward. But this is a subsequent proceeding to the first teaching the beat. During this part of

these lessons, the seven preliminary words of command will be constantly useful, and beyond these little more will be needed except the meaning of the wave of the arm, which is soon learnt, and which can hardly be taught well till the dog has some object in view. He soon begins to understand what he is wanted to do, and as he has learnt to obey his master and to believe in his superior powers and knowledge, so he now readily gives way to him in this particular. When, therefore, he works steadily on, he is encouraged by his master's voice occasionally with "good dog;" but should he "break fence," or chase birds or hares after the first few hours, he is stopped by "ware fence" or "ware chase," as the case may be. Pursuing these methods, the highly-bred pointer almost invariably begins TO POINT at the end of a few hours' work—that is, as soon as the acquired instinct of the individual breed is not overpowered by the natural appetite which all dogs have to chase anything which runs away. At first the stop is very hesitating, and the dog draws forward and puts the game up. Now is the time to come forward with "Toho!" which is quite useless and will be sure to be disregarded, if adopted before the disposition to point is shown in some slight degree. The point becomes dwelt on longer and longer as the dog becomes more tired, and the encouragement to do right by the word "Toho!" soon makes it last long enough for the breaker to reach the dog before he has sprung his birds; then patting him and encouraging him in every possible manner, the breaker waits patiently with his pupil for ten minutes, if the birds will lie as long; beyond which time there is no use in keeping up the state of excitement. Next walking crouchingly forwards, and keeping his eye on the dog all the time, with his hand up to restrain him from following, he puts up the birds, calling out "Down charge" at the same moment in a loud voice. The dog will perhaps come forward, but he must at once be made to crouch, and it is well to keep him down for a few minutes, repeating the "down" in an encouraging but sonorous tone. In this way the two first acts are completed, and then it devolves upon the teacher to begin the third, or BACKING, which is taught as follows:—A steady companion, whose point is always to be depended on, is put to work with the young one, who

should at the time be somewhat tired, and therefore ready to obey orders. Let the old dog work forward, and keep the young one either near the breaker, or in such a position that the latter can interpose between the two as soon as the old one finds. The moment this takes place, the breaker sings out "Toho!" and, with his hand up, stops the young one wherever he is. At first his attitude, when thus stopped, is merely that of irresolution; but in process of time, as he finds by experience that his fellow-dog has game before him, the association of ideas induces the rigid attitude peculiar to the breed, and the firm "backing" is the result, which comes at various periods and in different degrees of intensity, according to the purity of the blood in each individual. A half-bred pointer may be made to point with a little extra trouble, and he may be also made to stop when he sees another point; but his backing thus induced is without rigidity, and it can rarely be depended on except in positions where it is of little use—that is, whenever the master is close at hand. If there is much difficulty in developing this "steadiness behind," the young dog must be hunted in a check-cord; and when he rushes up to his fellow to deprive him of his point, he must be severely checked, and made to stand till his master comes up; when the position is still to be maintained, but with encouragement, by the use of the words "Toho! good dog, toho!" The great point is to stop at once any tendency to draw up to the pointing dog, for this unsteadiness behind has two ill effects: it induces jealousy in the old dog, and it makes the birds lie worse than they otherwise would. The fourth quality, or **DRAWING**, is one which cannot be fully taught at this time, inasmuch as it requires great experience on the part of the dog. Neither should it be permitted until he is quite to be relied on for steadiness, for it is apt to degenerate into the opposite extreme until the dog fully appreciates the object for which he is used, and is ready to work with and for his master instead of himself. On the moors, "drawing" or "roading" is especially necessary, for sometimes a dog catches scent and stands, but before his master reaches him the grouse are a hundred or a hundred and fifty yards off. Here, if he can gain no information as to their whereabouts, the shooter has little chance of getting within shot, while the

thoroughly educated animal would carefully draw up to his game, and if first-rate, would leave his point, go round them, and head them. Such examples as these are, however, rare, and when met with, they cannot be too highly prized. No education can instil these faculties into a dog of limited brains, and therefore the owner of a brace of puppies must not expect that they will come back to him from the breaker with a full development of them.

AUTUMNAL COMPLETION OF BREAKING.

In the two previous divisions of the breaking process the dog has been taught to do nearly all which he will be required to perform in the shooting season, but he has been barely taught the various acts required; for if he were to be severely drilled he would become disgusted, and "blinking" would be developed. Now, however, there must be no finching on the part of the breaker, who must firmly correct every fault, however slight, proportioning the punishment to it; but in all cases making the dog understand his error. It will inevitably happen that something wrong is done, but the faults will be venial if the previous education has been conducted by the same person as is now shooting over him, and if that person has been firm and consistent in carrying out his orders in the spring. The range being the first act which must be performed, should at once be attended to, and the dog should be worked by hand most carefully, not allowing him to take his own way for a single yard. This, however, should have been previously carried out during the last few days of the close time, for no one ought to shoot over a puppy (nor, indeed, an old dog), however steady he might have shown himself in the spring, without running him over similar ground two or three times previously. According to the nature of the beat must now be the range: if on an enclosed manor full of birds, the quartering must be so arranged as to keep the dog always within a hundred or a hundred and fifty yards at most of the shooter: if, on the other hand, it is a wild partridge country, or a northern moor, the dogs are made to range two or three hundred yards right and left, and their parallels are also wider apart. There is a considerable difference of opinion and practice as to the

best modes of beating ground, but so much depends upon the individual dogs, and upon the pedestrian powers of their masters, that very few directions can be given. The pace of the shooter should never be so great as to hurry his dogs, and yet he should not be so slow as to be long in reaching them when pointing. Here, as in most similar cases, a happy medium, which can only be learnt by experience, is the proper rule, but this is more easily understood than described. But supposing the nature of the range settled, and the dogs started off and kept at such parallels as shall be suited to the ground or to the fancy of the shooter, he must also exercise his temper in checking his dogs when they attempt to break through any of the rules previously made. When one points the other must be made steady behind him, and this with as little noise as possible, merely by holding up the hand. Walking quietly but quickly up to the standing dog, the game is put up, and, it is to be hoped, shot; and now comes the moment when the fitness of the shooter for breaking is tried to the utmost. If he is a pot hunter, he will either rush in and pick up his game, or he will disregard the dogs altogether and suffer them to move towards it or to leave their ground. Any of these acts is fatal to their progress and to his sport; the dogs should both be made to drop, if they have not done so, and should remain down till the gun is reloaded, when they may be (one or both) allowed to mouth the bird, or to aid in retrieving it if it is not killed, but only wounded. I do not myself like that pointers or setters should be used for this purpose, but others think differently, and shooters will of course please themselves. When this is done the game is disposed of, the beating begins again, and the whole act is repeated as often as the shooter can effect it.

But there are many *minutiæ* and delicacies of the art which demand practice in their proper fulfilment, as, for instance, in the drawing upon running game, or in sending the dog round to head them when so occupied. All this must be seen and practised to be carried out properly; and no directions for special cases can be of any avail. The principle only can be instilled, and this I have endeavoured to do in the directions already given, leaving the details to be filled up at discretion.

REMEDIES FOR FAULTS.

In conducting the breaking of dogs to the gun, it will be found that certain individuals contract faults, which must be remedied as far as possible. These are:—

1st. Hunting too low, or puzzling on all occasions—commonly known as “pottering.”

2ndly. Chasing when hares are on foot.

3rdly. Refusing to stop when another dog points, or to “down charge,” when the gun goes off, as the case may be.

For the first of these faults a mechanical contrivance has been invented, called the puzzle-peg, which is a projecting peg strapped on to the lower jaw in such a way as to prevent the animal reaching the ground with his nose, thus. Colonel

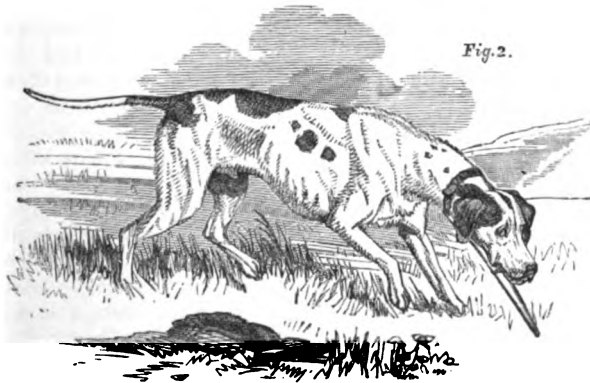

THE PUZZLE PEG.

Hutchinson has invented and described a mode of superseding the necessity for this, which I shall give in his own words. He is describing the preliminary education of a puppy:—“Your pup having become a tolerable proficient in these lessons, you may beneficially extend them by employing the word ‘Up,’ as a command that he is to sniff high in the air to find the hidden bread or meat, lying, say, on a

shelf, or on the back of a sofa. He will, comparatively speaking, be some time in acquiring a knowledge of the meaning of the word, and many would probably term it an over-refinement in canine education; but I must own I think you will act judiciously if you teach it perfectly as the initiatory lessons; for the word 'Up,' if well understood, will frequently save your putting on the puzzle-peg. For this you might be tempted to employ, should your dog be acquiring the execrable habit of 'raking,' as it is termed, instead of searching for the delicious effluvia with his nose carried high in the air."

Now, undoubtedly, if the dog can be taught to understand the word "Up," it is a gain; but let any one try to do this, and he will find the difficulty is not trifling, nor, if overcome, will it suffice at any great distance from the shooter. Yet it is chiefly under such circumstances that the dog "potters;" for few sportsmen care about it being done near them, inasmuch as they can encourage the dog by the voice, and with this aid he will seldom dwell for any time on a foot scent. But it is at a distance that the mischief chiefly occurs, and when the steady point is wanted, to which birds will lie. Here the voice is altogether objectionable, for it either cannot be heard by the dog, or if it can, it will at the same time disturb the game. I therefore hold that Colonel Hutchinson's plan is utterly useless, and that the puzzle-peg must still continue to be the only remedy for this fault. By strapping it on for days together, the dog at length learns the habit of hunting with his head high, though it will generally be necessary to return to it occasionally for some time. *For the second and third faults* the check-cord is applied in a variety of ways; but it is always intended to apply to those dogs which range too wide, or refuse to "back," or to "point," even, when very troublesome to break. It is merely a line of various degrees of size and length, according to the strength and courage of the dog; it may be generally of the length of twenty yards, and of good stout cord, well twisted, yet not too heavy. The object is not always to tire the dog, but to gain absolute command over his motions, in bringing him back to you, or in stopping him from chasing. Of course, the longer and heavier the cord, the more it tires the





GROUP OF SPRINGERS.

dog: but some animals are so delicate, that they refuse to range with it, and yet are difficult to stop; altogether, however, it is an exceedingly useful mode of bringing dogs under command, but it is not so necessary for the pointer as for the spaniel, or even the setter, which is a bolder, hardier, and more headstrong dog than the pointer. In very unruly animals it is applied to a leathern collar containing short spikes in its internal surface, and the cord being suddenly pulled, the "spiked collar" enters the skin and gives considerable pain. With a hearty pull, however, the plain collar punishes sufficiently for most cases, and I should rarely think of using anything more for the purpose of breaking the dog from either of the vices for which this remedy is provided.

CHAPTER II.

FIELD SPANIELS AND THEIR BREAKING.

GENERAL REMARKS ON SPRINGERS AND COCKERS—THE CLUMBER AND SUSSEX SPANIELS—THE NORFOLK AND OTHER BREEDS—THE WELSH AND DEVONSHIRE COCKER—THE KING CHARLES AND BLENHEIMS—HUNTING SPANIELS BY FOOT-SCENT—ALL TAUGHT TO RETRIEVE—PRELIMINARY EDUCATION—ENTERING AND BREAKING.

GENERAL REMARKS ON SPRINGERS AND COCKERS.

FIELD spaniels, as distinguished from water spaniels and toy dogs, are divided into springers and cockers—the former being used for hunting pheasants and hares, while the latter are chiefly employed as is designated by their name, for the woodcock. The springer is considerably larger than the cocker, and heavier in frame, as well as in the head. From this large size he is unable to follow out any but large runs in covert, and will often pass the woodcock as a consequence of this. Indeed it sometimes happens that the pheasant or the hare will pass where he cannot squeeze his body, but generally he will contrive to thrust it through with great fatigue to himself. Of the springers there are three chief varieties—the

Clumber, the Sussex, and the Norfolk—as shown in the annexed illustration; while among the cockers there are no specific and well-marked kinds now in use, but the Welsh and the Devonshire, though in many parts we meet with small spaniels used for the purpose which cannot be referred to either of these subdivisions of the dog.

The *Clumber Spaniel* is a large, very long, and low spaniel, of a white and lemon colour, with a wide and flat head, and long ears. This breed has been confined to the Duke of Newcastle's kennels until within the last few years, and hence its name "Clumber;" but it is now very generally dispersed over the south of England—indeed, wherever preserves of pheasants are met with, this spaniel is almost sure to be treasured. His legs are remarkably short and strong, and his pace in hunting is slow; while his muteness is admired by those who only require him in aid of the beaters in a *battue*. For wild pheasant shooting he is not so useful, as his master cannot tell where he is, or when he is on game. His coat is thick, but silky rather than woolly, and he is well feathered all round. A good team of these spaniels is worth 30*l.* a piece.

The *Sussex Spaniel* resembles the Clumber in being a long, low, and strong dog, but he is not so weasel-like in his proportions, and is of a deep liver colour instead of being lemon and white. He is also rather stronger and heavier, especially in the forehead, but the chief difference is in his "questing," or giving tongue instead of being mute. This dog is admirably represented in the engraving which faces this article.

The *Norfolk Spaniel* is shorter in the back than either of the two above described, and he is generally of a black and white colour, sometimes liver and white, but almost always having more or less ticks about the body. All the large varieties of field spaniels, without any crisp curl of the hair, and not coming under the designation of Clumber or Sussex, are usually called Norfolk spaniels.

The *Devonshire and Welsh Cockers* are two breeds, each used in the part of Great Britain which is implied by the name, and so closely resembling each other that I know no means of distinguishing the one from the other. Both may be described as light-working and active dogs, considerably



L. H. C. 1875

COCKERS.



less than the springers, and showing far more liveliness in their actions. All the field spaniels carry their tails low and work them in the same position, but this property is very remarkable in the cockers, which also work them more quickly than the springer. The Devonshire and Welsh breeds are always of a rich liver colour, as represented in the accompanying group, where the dogs in the background are two of the many nondescript varieties of this subdivision.

The *King Charles's* and *Blenheims* originally belonged to the group known as cockers, but they are now only used as toy-dogs.

HUNTING OF SPANIELS BY FOOT-SCENT.

Unlike the pointer and setter, the spaniel always works with his nose on the ground, and does not carry his head in the air feeling for a body-scent as it is wafted towards him on the gale. It is quite true that occasionally he looks for and finds a pheasant in covert, which has been for a long time lying, and here he undoubtedly recognises the scent given off by the body, but this is done at no great distance off; and though he tries all heights to which he can reach, his carriage is not limited to the one, steady and bold, which is found to suit the pointer. Hence there is, in my opinion, no objection to a whole team being taught to retrieve, if it can be done, excepting that where the task is divided among a number, it is not so well performed for want of sufficient practice. Nor does it often happen that an average dog will retrieve thoroughly, the task being a very difficult one, and requiring the selection of one dog out of a goodly number in order to obtain a really accomplished retriever. I need scarcely remark that if, as I have known, spaniels are used in the open, they work somewhat differently to their covert style, with a higher carriage, but still not at all like the pointer. There are here, as in all rules, exceptions; but, nevertheless, the rule holds good with which I commenced this paragraph.

ALL SHOULD BE TAUGHT TO RETRIEVE.

Although, as I before remarked, all spaniels are not capable of being converted into good special retrievers, yet all should

be taught to bring game to their masters, when they have it in their possession. Without this quality they are apt to remain with a wounded or dead hare or pheasant which they may come upon in covert, and their services are thus lost for hours. Still it is by no means necessary that the power should be employed, and a special dog, whose talents can be relied on, may be put on the scent of wounded game whenever there is a necessity for the services of such a dog. Every spaniel must be made perfectly steady at "down charge;" and until the gun is reloaded, not even the regular retriever must be allowed to move towards the wounded game. Then the rest of the team being called to heel, or kept "down," the retriever is set to work under his master's or the keeper's superintendence, and while he is carrying out his office the beat may proceed, if the services of the one or the other can be dispensed with.

PRELIMINARY EDUCATION.

Whether for covert hunting or retrieving there must be a preliminary education of the young dog, which should embrace all the acts directed for that of the pointer, excepting the "Toho!" (see p. 127.) This last is unnecessary, because the spaniel is not wanted to stand, and thus the six first which are there enumerated are all that can be required. These must be diligently instilled, for steadiness is wanted to a greater extent in covert than out. Dogs, when concealed from view, are more tempted to do wrong, inasmuch as they also lose sight of the controlling power, and hence the power of habit must be more complete; so that it is seldom till these dogs have been used for a couple of seasons at least that they are sufficiently under command. But by constantly taking them out when young and keeping them very steadily under command much may be done. But, nevertheless, in almost all cases, from their naturally high courage, when they are shown game, it will be found that it has all to be gone over again; and though the task is rendered far more easy from having been early commenced, it is still a long and a tedious one.

ENTERING AND BREAKING THE SPANIEL.

I have already said that the spaniel's preliminary education must be commenced very early, and the same may be said of his entry to game and breaking to the gun. A dog which is left till he is a year and a half old will give a world of trouble, while a young puppy of seven or eight months may be broken in half the time. Spaniels are naturally of a most impetuous temper, and moreover they have not the instinctive tendency to stop or stand, which so much assists the breaker in his education of the pointer. When quite young—say at six or seven months of age—they should be taken out and worked in hedgerows and little spinneys and coverts, where they cannot get away far. Here they soon learn to know the scent of game, which is in itself more delightful to game-dogs than that of other animals. In some breeds, indeed, the fondness for particular kinds of game is well marked, and the "cock," for instance, will be recognised with a whimper indicating much greater pleasure and enjoyment than that which is displayed on ordinary occasions when a pheasant or a hare is owned. Great caution is necessary, lest the young dog takes to "self-hunting." He should rigidly be made to work with and for his master, and should never be allowed to feel that he is at liberty to search for game on his own account. If he does this, he will be quite useless, and not only will he start off whenever he is loose, in season or out, but he will get away to the other side of the covert, and play such pranks as will spoil the day's shooting. When spaniels are intended to be kept to any special game, such as cocks or pheasants, they should never be allowed to hunt anything else, but generally they are taught to work out all that comes before them, and if they will only indicate the nature of that which they are after, they are to be the more highly prized. In order to keep them to one kind, it is only necessary to "rate" them for hunting any other when it is discovered. "Fur" is often discouraged, and for those who do not want to kill rabbits or hares in covert, it is desirable to stop a spaniel from speaking to it the moment his error is discovered. But the grand essential in breaking covert spaniels is to make them keep

within forty or fifty yards of their masters, so as to provide against their pushing up game out of shot. If this is well carried out, and they are made steady to "down charge," while at the same time they possess good noses, there is little more necessary; but this, little as it looks on paper, will be found much more difficult to teach than the more complicated task of the pointer. The temptations to the spaniel are constant; he crosses foot-scents at every few yards, to follow out which may perhaps lead him a long way off, and yet his appetite is against leaving them unworked out. Nevertheless, he ought to abandon them, unless he finds, on giving tongue, that his master is not following him; and it is in producing this waiting for orders that the special difficulty resides. The pointer must also wait till he finds, but when he is under the stimulus of scent, he is no longer required to hesitate what he shall do: he knows his duty, and must stop dead, unless under circumstances when he may be called upon to "draw." The difference between the two tasks is here clearly shown, and it need not occasion surprise that the one is so much more difficult to teach than the other, because it supposes reasoning power to be displayed under circumstances of great temptation. But the first thing to be done is to instil the desire to hunt, without which the puppy must remain useless. If no inclination is shown when first taken out, let him be put on the scent of pheasants just as they come off their feed, and as they are returning up the hedgerows. At this time the young dog will only drive them into their secure retreats, and will do little harm, if the practice is not continued day after day in the same place. Until the young pheasants are able to fly, this must not be attempted, as they may then be easily caught and killed, but as soon as they can rise into the trees, they are safe. It is well to avoid entering dogs intended for feather to fur; and if this is done, pheasants are the only winged game that can be selected. Spaniels should always be taught to drop to the gun and hand, as I have already explained, this being a part of their preliminary education, when it may be taught by means of the pistol; but it must be enforced on all occasions when game is before them. A retriever is very useful, as it is very difficult to prevent the whole train of spaniels from bringing game, if any one is

allowed to do so; but they soon learn to "down charge" strictly, and then the retriever goes to the dead bird, and retrieves it for his master. In first entering young spaniels to hunting the hedgerows, if the breaker is out alone, they should not be allowed to go through to the other side, but should be kept carefully on the same side as the shooter; afterwards, however, when they are accustomed to the range, and keep watchfully eyeing the sportsman, to see that he is within reach, they may be sent to the other side, and put to hunt everything out on the same side as the gun, which is always the most effectual mode with a single shooter. When the young spaniel is first put into a large wood, and is beyond the supervision of his master, he often ranges the entire covert, and does immense mischief to the sport, driving everything out of shot. He should be well loaded with lead in a leathern collar, or one of his legs should be taken up into his collar, or a strap should be buckled tightly just above the hock, which will prevent his using that leg. He must be put to hunt with two couple of steady old dogs, even if he is so confined as to do nothing. He will soon learn to imitate his fellows, when he sees them pay all attention to the gun, and when he finds that game falls to their hunting, whereas he has never yet succeeded in obtaining such a result. After a time, his leg may be set at liberty, and he may perhaps take to his work kindly enough, and refuse to leave the other dogs far. He will not probably do much good, as this work requires great experience, but he will do little harm. It cannot be expected that the spaniel will learn his business in one season, and he is seldom perfect in two; but he will help to do the looking-on part, and will animate the old, stale, but steady and clever dogs, to increased exertions. Many sportsmen are constantly encouraging their spaniels by cries of "Have at 'em!" "Cock! cock! cock!" &c. &c.; but this is perfectly useless, the slightest whistle being sufficient to indicate the whereabouts of the gun, and more than this, interfering with the sport, because it shows the game what they have to avoid, and when to avoid it. If the spaniel is fond of his master, and accustomed to work for him, he is as much occupied in watching his motions as in seeking for game. These dogs have a very strong love of approbation, and very fortunately

this is so, because they are so much more beyond the master's control than the pointer or setter. There is no objection to beginning to beat the coverts early in the morning, which is as good a time as any for pheasant shooting; and most ardent sportsmen of the old school select that time, especially if they mean to beat the hedgerows. This they can do as the birds are returning from their feed, after which they should follow them into covert, and with a wave of the hand order in the spaniels, with "Have at"—pronounced "Haave aat"—which should only be used just at first, by way of encouragement. After this—keeping them carefully near him—the shooter should watch for the one which "opens," and press forward to that dog; as soon as he gets to him, the little creature is sure to push on, and will, if of a good nose, soon either undeceive him by silence, or drive up a pheasant or cock. The great point is to rush well into the thick of the scent, getting to the dog throwing his tongue, wherever he may be, and being regardless of thorns or brambles. Nothing can be effected without this rush, as pheasants will run for many yards before dogs, if not rapidly pushed, and will generally get up far out of shot, or so protected by the trees as to be defended by them from the gun. Little light men have consequently a worse chance at this sport than strong and tall ones, who are able to raise their arms and guns above the underwood, and carry all before them. It is seldom that a pheasant can be marked into another part of the same covert, and indeed, if it is so, the bird seldom remains near where he alighted, but runs a long distance, and then lies quietly in the thickest and most impenetrable part. If wild-pheasant shooting is to be followed with much success, the spaniels must be broken from "fur" both in the form of hares and rabbits, as they will otherwise neglect the pheasants, and take to the four-footed game. This can only be done with spaniels whose breed is very pure and free from the stain of the beagle, which so many of our old spaniels are crossed with. The Clumber and also the Sussex spaniels, when pure, are said to disregard hares and rabbits, until thoroughly entered to them, and always to prefer "feather" to "fur;" and no doubt it is the case where the ancestors have been strictly kept for generations to pheasants and cocks. But when they are allowed to hunt all



DEERHOUNDS.

kinds of game. they are not so very oblivious of their natural instincts as is commonly reported.

Such is the method of breaking the spaniel, with the exception of that part which treats of his education as a retriever; but as the mode of effecting this is the same as for a dog specially provided for that purpose, and as this latter subject will next come under consideration, it will be desirable to treat of the two together.

CHAPTER III.

RETRIEVERS AND RETRIEVING BOTH ON LAND AND IN THE WATER.

LAND RETRIEVERS—THE DEER-HOUND—THE SMALL NEWFOUNDLAND
CROSSED WITH THE SETTER—THE CROSS WITH THE POINTER AND
TERRIER—THE BEAGLE AND TERRIER CROSS—WATER RETRIEVERS—
THE PURE ST. JOHN'S NEWFOUNDLAND—THE POINTER AND TERRIER
CROSS—THE WATER SPANIEL—ENGLISH AND IRISH—TEACHING TO
RETRIEVE ON LAND—AND ON WATER.

Retrieving is the art of recovering animals after they are partially disabled by the gun or rifle. Thus the deer-hound is slipped when the stag is not brought down by the rifle, and follows him up either by scent or view. The land retriever works out the many windings of the wounded pheasant, grouse, or partridge; and the water retriever brings to his master the crippled duck, which would otherwise escape, or sometimes the dead bird which lies beyond the reach of man when he has not the aid of a boat, or of the assistant which I am now describing.

The *Deer-hound* is a large and very elegant specimen of the dog, his proportions being quite as good as those of the grey-hound, and resembling exactly in shape the rough variety of that beautiful dog. The appearance and shape of the deer-hound are better described by pictorial representation—such as that which faces this page—than by pen-and-ink sketches. It may, however, be mentioned, that the purity of

the deer-hound is judged of a good deal by the coat, which should be very wiry and somewhat long, without being woolly. In colour these dogs are fawn, red, black, or brindled, and often of a greyish shade, composed of a mixture of bluish black and white hairs. A cross of the foxhound with either the smooth or rough greyhound is now very often substituted for the old deer-hound, which is every year becoming more and more scarce. The object is to obtain a fine nose, so as to hunt a cold scent, if necessary, but united with such speed as to be able to keep the stag in view when once the dog has been sighted. High courage must also be combined; but there is an objection to the use of the bulldog in breeding these dogs, because the tendency of the former is to go to the head, where the horns are dangerous weapons. Hence, though nothing gives such an utter disregard of these horns, the cross with the most courageous of dogs is obliged to be abandoned.

The *entering* of the deer-hound is a very simple process, requiring merely the example of an older companion, and plenty of practice.

THE LAND RETRIEVER.

In the group which accompanies this article three kinds of retrievers are drawn with great accuracy. 1st. The cross between the small Newfoundland and the setter, which is almost always black. 2nd. That between the pointer and rough terrier, the use of which is advocated by Mr. Colquhoun. And 3rd. The small retriever, which is sometimes used in partridge shooting, and is the result of a cross between the beagle and terrier.

The *large black Retriever* is intermediate in form between the Newfoundland and the setter. The body is lighter and less unwieldy than the former, but more massive than most of our setters. Head heavier than the setter's, with shorter ears, and less vivacity of expression about the eyes. Indeed, in every point he may be described as partaking of both sides of his parentage, so much so that he readily takes the water, like the Newfoundland, and may easily be taught to stand and back like the setter. The nose of this dog is often very



RETRIEVERS.



good, and he will retrieve wounded game as well as, or perhaps better, than any other kind.

The *Cross of the Pointer and Terrier* is not so much used, but it is strongly advocated by that excellent sportsman, Mr. Colquhoun, and on that account it is worth a trial. A strong, useful frame, with great hardiness of constitution, is the result, capable of bearing cold and wet as long as any other dog. A specimen is represented as one of the group of retrievers opposite this page.

The *Little Terrier and Beagle Cross*, which is seen in the background of this group, is a great favourite with me, and I have never seen any kind of dog perform more extraordinary feats in retrieving than this. The drawback is that he is too small to carry a hare, but for all other purposes he is invaluable. The best cross is about three parts rough terrier to one of the beagle. The terrier may be either the Dandie Dinmont or the Scotch dog; but in selecting one he should possess a good nose, and should have been used for hunting game.

WATER RETRIEVERS.

Besides the Newfoundland and its cross with the setter or spaniel, there are also two or three breeds of pure water spaniels used in wild-fowl shooting. The form of the Newfoundland cross does not differ from the land retriever of that breed, as represented in the last engraving.

The *Old English Water Spaniel* is a large, rough, and curly-haired dog, generally of a liver colour, with or without a little white about the legs and breast. The head is narrow and long; ears of the average length in the spaniel; body strong, especially in the loins; limbs large and bony; feet spreading, and therefore said to be web-footed; tail covered thickly with short hair, without any brush, and ending in a point; Coat curly, and not liable to get wet to the skin, from possessing an oiliness at its roots, which is very essential to the power of resisting the action of water. This dog swims and dives well, but he requires a vast deal of breaking to render him sufficiently obedient. He is represented in the illustration on the left-hand side.

Of the *Irish Water Spaniel* there are two kinds; the North

of Ireland dog, which is given in the annexed engraving; and the South Country water spaniel, of which I have never seen a well-marked specimen. Both are of a liver colour, but the former has often more or less white, while in the latter this is entirely absent. The northern dog is also longer on the legs, with short ears, having little or no feather on them, and both the legs and tail being also almost free from this ornament, and covered instead with a short curly coat, as is also the rest of the body. The southern dog, on the contrary, has long and well-feathered ears, tail round also, and pointed, never being carried above the back; head covered with a perfect top-knot, coming down over the forehead in a peak. These dogs are valued very highly in Ireland, but they are little known out of that country. The northern Irish spaniel is, however, common enough in England and Scotland.

TEACHING TO RETRIEVE.

The fondness for carrying is displayed by some puppies to a remarkable extent, while others are altogether without it. The latter will never make good retrievers, in spite of all the efforts of the best breakers, but the former will only require a little practice to become the most valuable assistants in shooting. I am often asked, "How am I to *begin* to teach my puppy to fetch and carry?" Now, this is rather a difficult question to answer satisfactorily, because in itself it plainly shows that there is an absence in the individual for whose benefit it is asked of the special faculty to which I am now drawing attention. If the puppy is likely to become good in this line, he will *naturally* display his "fetch-and-carry" propensities, and will be constantly seen with a ball or a piece of stick, or perhaps a stone in his mouth, asking you to throw it for him. Every one accustomed to dogs of this kind must have seen this, though it is not so common among animals which are not generally long in the company of their masters, house-pets being particularly likely to display it. There are means by which young dogs may be taught to carry, but then the act of teaching is almost sure to render them "hard-mouthed," an effect which spoils them entirely and for ever, for no fault is more difficult to eradicate. The



WATER SPANIELS.



mode by which carrying may be taught consists in letting the puppy, especially when teething, lay hold of a handkerchief or towel, or a bunch of feathers tied to a cord, and drag it towards him ; a slight resistance aggravates him exceedingly, and makes him fond of possession, which he may be allowed to have for a few seconds, and will then proudly carry off his trophy, the other end of which is still to be held, but not checked. In a few seconds he may be again warned by a gentle pull that he is not yet master of it, and this renews the desire, which ultimately becomes confirmed, and any dog may thus be taught to carry a stick ; but, as I before remarked, he will inevitably become "hard-mouthed."

After giving him only a few of these lessons daily, and not nauseating, he is, as he grows older, accustomed to fetch anything which is thrown, and often may be made to pick up whatever he is told to lift, by the words "Fetch it," pointing to the particular article. In throwing the glove for him to fetch, occasionally throw it into high grass, or in the garden, into carrots or potatoes, then cry "seek, seek," and encourage the dog to look for it, by appearing to look for it yourself. After six months of age, the puppy may be taught to find and bring young rabbits, purposely concealed in grass, &c. : but should never be allowed to hunt rats, since they, by their bite, raise the animal's ire, and cause him to retaliate, and consequently to become hard-mouthed with his game. When the retriever has learnt to find and bring young rabbits without injury, and is under very good command, he may safely be taken out with pointers, but at first should be led by a servant, and only suffered to go loose when a bird is killed. He will then at once proceed to find it, and bring it to you, during all which time the pointers must be still "down," let the search be ever so long and distant. After a short time, when the retriever has been thoroughly accustomed to the work he has to do, he may be allowed to go at large, keeping him always at the heel of the shooter, and only suffering him to retrieve at the words "Seek, seek," if the birds are wounded, or "Fetch it," if dead. The retriever should always be made to bring the game to the actual foot, or even the hand of the shooter, and not lay it down at a distance, as he may choose

sometimes to leave it on the wrong side of a fence or river. In teaching these dogs to take water, it is only necessary to begin in the summer, and to avoid throwing them in. They will always, at that season, readily enter the water, and fetch anything floating out of it. Nothing is so easy as to teach a retriever to do his work, but the difficulty is to keep him at heel till ordered off; yet by firmness, and a little system of rewards and punishments, this may always be effected. A "hard-mouthed" dog is most difficult to break of his bad habit, and indeed he may almost be said to be irretrievably spoiled. When, however, a puppy has shown natural abilities for this office, and has only taken to pinch game from over-eagerness, he may be mended in this respect by putting on a check collar, and taking him up very steadily and slowly to his game. Give him, in the course of the walk up to it, several monitory pieces of advice, such as "Steady, boy, steady," by which his ardour will be damped, and if these fail, check his collar smartly. Then let him very gradually and slowly take the bird into his mouth, keeping his nose just away from it till he has had time to inhale the scent. When he grasps it, still caution him, but let him keep possession for two or three minutes, and then make him drop it into the hand. By proceeding in this slow and cautious manner, the dog may get over his tendency to grip his game, but in the majority of instances, such an animal never becomes quite what he ought to be. Balls stuck full of needles, steel bits which keep the mouth slightly open, and other similar devices, have been invented, but none of them are of much service. The bit or bridle, as it is sometimes called, answers as long as it is worn, but few people would care to have a retriever which bears the unmistakable marks of being a bad one.

The WATER RETRIEVER requires very little special teaching in addition to that which has been already alluded to as necessary on land. But he must have a great deal of practice before he is really useful, and a good water-retriever is not often to be met with. Of course he must be induced to "take water" readily, but those breeds which are likely to become good in this capacity require very little education in this particular. The water retriever should commence on land, like the land retriever, to seek for gloves and young

rabbits, &c., and to bring them uninjured to his master. After a time, he may be taught to bring a ball or glove from the water, which he does more readily even than on land, but is very apt at first to deposit it on the shore, as soon as he reaches it, in order that he may shake himself clear of the water hanging to his coat. This should be discouraged, as it is very apt to induce the dog to leave his game on the edge of the water as soon as he comes out. When these dogs are required for punt-shooting as well as river-hunting, their education is better commenced on the river-side than in the punt. Nothing answers better for this purpose than the shooting of "flappers," which usually comes on in July and August. The water being then warm, and the young birds awkward, and not very good divers, great encouragement to persevere is afforded to the dog, and he may be easily induced to swim more or less for hours, and to hunt the side of a brook in the most ardent manner. There is very little difficulty in entering these dogs to wildfowl, as they seem to have a natural bias that way; but they should be carefully broken from rats, which abound on the banks of rivers and ponds. The only art consists in confining their range, by making them beat to hand, and in persuading them to retrieve wounded or dead birds. The range is much more easily taught the water spaniel than the land variety, because he is almost always in sight of the shooter, and always within the sound of his voice. If, therefore, the puppy has been taught to come in at the word "Back," and to turn to the right and left on land, in obedience to the hand, as in ordinary spaniel-breaking, he will be sure to obey in the water, where he seems to ask for the directions of his master. The eye of the swimming dog is only able to command a small circle, being very little raised above the level of the water, and therefore he cannot see far from his nose; but by watching the hand of his master—for the voice should not be used more than necessary—he is often directed to the right spot, and afterwards is glad to claim the assistance which is found to be so useful.

CHAPTER IV.

RABBITING—RABBIT DOGS—FERRETS AND
FERRETING—SHOOTING PONIES.

RABBIT TERRIERS—THE ENGLISH TERRIER—THE SCOTCH DOG—THE
DANDIE DINMONT—THE SKYE TERRIER—THE HALF-BRED DOG—
FERRETS USED IN AID OF THE GUN—DESCRIPTION—BEARING AND
FEEDING—DISEASES—MANAGEMENT IN HUNTING.

RABBIT TERRIERS.

THE *Terriers* which are used for rabbiting, either with or without ferrets, are the smooth English dog, more or less crossed with the bulldog, the Scotch terrier, also, more or less similarly crossed, and the Dandie Dinmont. The Skye terrier is sometimes used for this purpose, but he is not equal to the above kinds. In any of these varieties, the terrier is a strong, useful little dog, but unless he has a cross of the bulldog, he is generally a rank coward.

Whatever dogs are employed for the purpose of working rabbits out of hedgerows and small coppices, whether terriers, spaniels, or beagles, if ferrets are also employed, should be carefully broken to them, for otherwise a valuable ferret may easily be killed or spoiled. No dog answers better than a good terrier, which is easily kept in command, and is more readily quieted at the moment when silence is all-important; I shall therefore merely allude to the varieties of this dog which may be used.

The *Old English Terrier* is a smooth-haired dog, weighing from seven to twelve pounds. His head is flat, with a jaw tapering neatly off, and slightly overhung, if not crossed with the bulldog; eye *small* and bright; ears, when not cropped, short and slightly pricked, but turning over at the points; neck strong and long; body very neat and compact, with strong loins and deep chest, the back ribs not being very deep; fore legs strong and straight, and the feet round and

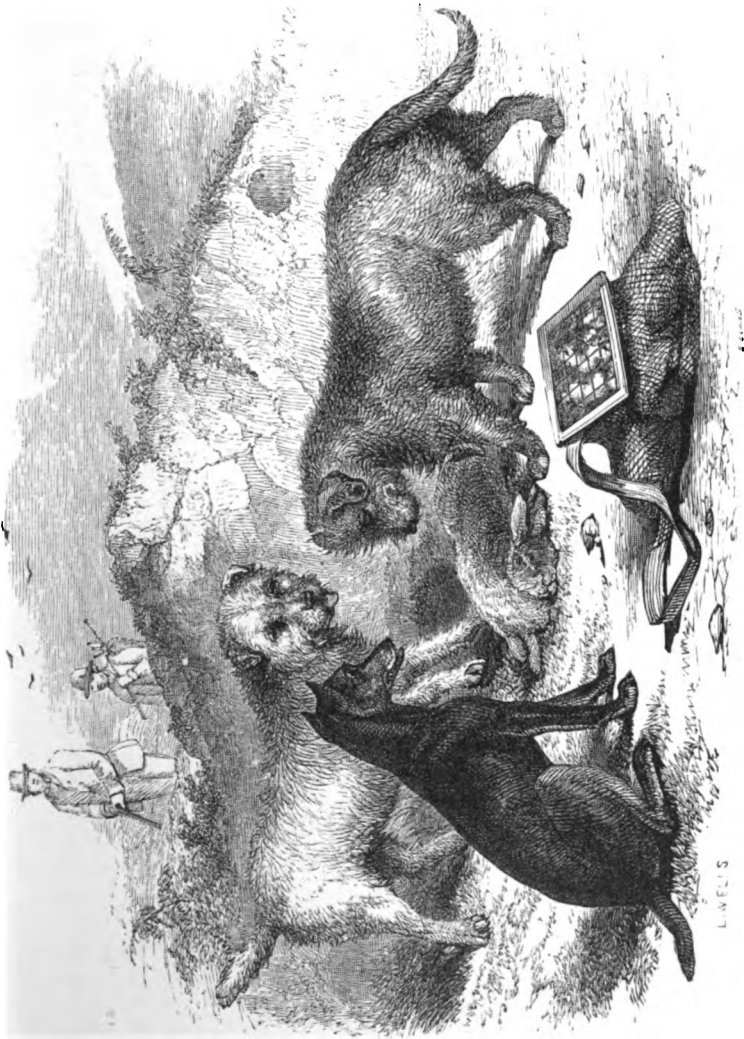

RABBIT TERRIENS.



hare-like, not resembling those of the cat; tail fine, not carried over the back; colour most frequently black and tan, but some breeders assert that true terriers are of almost every colour which can be mentioned. My own opinion is that, unless they are crossed with the bulldog, the colour should be black and tan, with as little white as possible. This dog hunts rabbits well, but he has not courage enough for vermin.

The *Scotch Terrier* resembles the English dog in all but his coat, which is rough, wiry, or broken haired, three terms for the same thing. The colour may be black and tan mixed with white hairs, or red, mixed in the same way, or white with more or less of the other colours above mentioned. This dog is more hardy in all respects than the English terrier, and has an equally good nose.

The *Skye Terrier* is a very long, low, and strong dog, and if bred in or near his native country, he is quite capable of being used to hunt rabbits; but in the south he has so long been kept for toy purposes only, that it is scarcely necessary to allude to him here.

The *Dandie Dinmont Terrier* immortalized by Sir Walter Scott, is intermediate in size, roughness, and length between the Scotch and Skye dogs. When of a good strain, he is an excellent rabbit dog. In colour he is invariably either "pepper" or "mustard," the former being greyish black with tan legs and muzzle, and the latter red shot with grey hairs. Both have long, silky hair over the eyes, and standing out from the muzzle; the legs are short, body long, shoulder low, back slightly curved, head large, jaws long and square, ears large, and hanging close to the face, eye full and intelligent, tail slightly curved and carried over the back like that of the hound; weight about fourteen pounds.

The *Half-bred Terrier* consists of any of the above kinds crossed with the bulldog, and shows the general appearance of the particular stock with a larger head and jaw, which is more or less overhung. These dogs are far more courageous than the pure bred terrier, and will stand wet and cold, as well as hard work, much better; the cross is, therefore, generally preferred for ferreting or hunting rabbits, but it should not be nearer than the third or fourth remove from the bulldog.

FERRETS USED IN AID OF THE GUN.

The ferret is used for taking rabbits either with the aid of nets placed at the mouths of their holes, or by shooting them as they come out. The latter is the method which more particularly brings them under our notice in the present book.

The FERRET (the two varieties of which are delineated in the accompanying engravings) originally came from Africa, through Spain, from which latter country the whole of Europe has been supplied. In length it is about fourteen inches, the ears are round, eyes red and fiery, colour pale yellowish white. The dark-coloured variety is crossed with the polecat, and is not a pure bred animal. These cross-bred ferrets are supposed by some to be more hardy than the white, but there is no such difference in reality between them, and for some generations they are wild and unmanageable. In choosing ferrets for rabbiting, the largest should be taken in preference, especially for rocky ground, but in some soils where there are no chasms likely to occur in the earth, a small ferret will answer well enough.

REARING AND FEEDING.

The hutches in which ferrets are kept should be placed in a dry room well protected from the weather. The floor of the hutch must be kept very clean, and for this purpose a false wire bottom answers well, having in a drawer below it sawdust or chaff, which will absorb the moisture, and can be removed with it every day. By adopting this plan, ferrets may be kept comparatively sweet, and even without the wire, by changing the sawdust, or chaff daily, a sufficiently wholesome result may be produced. The retiring box, or sleeping place, should be small and without any false bottom, as the ferrets, unless they are mismanaged, will never dirty it: it should be freely supplied with clean hay and wool, as they like to be warm, but the box should be ventilated in proportion. A trustworthy correspondent of *The Field* (High Elms), thus describes the hutch used by him:—"The box itself should



THE WHITE FERRET.



THE POLECAT-FERRET.



be three feet six inches long, one foot six inches wide, and one foot six inches deep. The feeding compartment (formed at one end) must be one foot taken out of the whole space, the sleeping place adjoining it one foot three inches, and the other compartment one foot three inches also. To divide each place from the other, strips of wood must be nailed inside the box to the back and front, leaving spaces between the strips to allow of a thin board sliding down pretty tight. About four inches from the foot of these partitions cut out a round hole three inches diameter. Over each of these holes make a small door to work on a screw. To each of these doors have a stiff wire, put on to the door with a screw, but with the end of the wire projecting through a hole in the front of the ferret box. Each of the three compartments must have a separate lid. When I describe the rest of the arrangement, the uses of these sliding doors and separate lids will be apparent. For the last compartment have two wooden trays made, lined and covered on the sides with zinc plate. Have to these trays wire handles, nailed at two opposite corners, and rising up like a bow. The trays being made to fit easily into this compartment are lifted out by the two handles. The box is now complete. The sliding door to cover the hole in the feeding compartment may be on whichever side is preferred. The other sliding door must be in the sleeping side, so as not to interfere with the slipping down of the tray. The sides of these trays must be four inches high. They will thus come just under the hole in the division. I should be inclined, however, to recommend the sides as being about six inches high except at the hole, where a piece can be hollowed out. People acquainted with the habit of ferrets will see why I recommend the sides to be pretty high. Mine were about four inches, but six would be none the worse. Into the tray you must put some dry sand or sawdust, about an inch or two deep, and every day, or at most every two days, empty it out, wash the tray and put it in the air to dry, while you substitute the other. Let the ferrets have a warm bed of hay and wool. When you feed or clean them, pull the wire of the place you are about to open, and thus close the door. This is a very needful precaution, for I should say that the task set to our friend

'Sisyphus,' of unhappy memory, was a joke in comparison to that of keeping three or four ferrets from oozing out of the open box when you want to shut the lid again. Keep the box in a dry place, not cold."

For food, bread and milk should form the staple, with the addition two or three times a week of a little animal food, such as butcher's meat, heads and necks of poultry, or what is best of all, small birds or young rabbits. They should be fed once a day, the bread and milk being given lukewarm, and the birds as soon after they are killed as possible. Some milk is injurious, and the pans in which they are fed must be scalded daily, and should be of earthenware or metal, not *wood*. The quantity must depend upon the condition, which will vary greatly in different animals, they should be so fed as to be rather low than fat, and especially when they are about to be used.

The bitch ferret must be allowed to breed, or she pines and becomes diseased. She goes with young forty days, and the young are born blind and remain blind about a month or six weeks, but they feed on their mother's bread and milk before they can see, as well as upon the milk which they obtain by sucking her. In a fortnight after they can see they may be weaned, and then their tuition must at once be commenced. For rabbits very little more is required in this way except to let the young ones become accustomed to the appearance and voice of their master, so as to come to him when called. This is easily effected by constantly feeding them, but for ratting they must be taught to attack the rats. In handling them roughness should always be avoided, and they should be accustomed to be taken up without fear, the neck being the proper place to lay hold of. With a pair of leather gloves, if they do bite at first, the pain can be endured, and they soon leave off the attempt to hurt their feeder when they find no resistance offered. They must also be accustomed to the muzzle, which is applied in various ways, as will presently be described.

DISEASES OF FERRETS.

These little animals are subject to a kind of distemper generally when they are just weaned, which is called "sweating," and which is better let alone. Foot rot is also common, caused by a want of proper cleanliness and ventilation, and here prevention is much more easy than cure. When it appears, the claws grow long and ragged, from the animal not wearing them away by friction; the toes are red and raw, and the poor creature is terribly lame. Several remedies are adopted, but the first thing to be done is to cut the claws as close as they can be shortened without reaching the quick, then touch the raw parts with blue-stone, and keep them dressed with an ointment composed of equal parts of mild mercurial ointment, simple sulphur ointment, and tar ointment. By repeatedly applying these remedies, and the use of great cleanliness, the foot rot may generally be got rid of.

MANAGEMENT IN FERRETING.

After hunting the young ferret two or three times with the old bitch, she generally takes to the work, and will readily enter the rabbits' holes and drive them without further trouble. The ferret should have been fed with only half the usual allowance on the day previously, and this will make it the more eager. Sometimes ferrets are allowed to enter rabbit holes without being muzzled, but the usual plan is to muzzle them in some way. Of the various modes adopted, the most efficient is that by means of a fine cord, which is tied over the nose and neck in the following manner:—Get some fine whipcord or strong twine, cut off a piece long enough to go round the neck, and about four inches over. In the middle of this tie a small loop, as at Fig. 4; then take another piece about eight inches long, and double it, tying two knots (Fig. 5, *b c*) at such a distance as to allow the nose to be admitted between them. To put these on, first tie the string (Fig. 4) round the neck so that

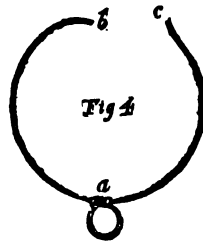

the loop (*a*) is underneath ; next place the nose in the loop (*b c*, Fig. 5), and slipping one of the ends of the first string



(Fig. 4) through the noose (*d*, Fig. 5), tie the two tightly together ; next pass one of the ends at *e* (Fig. 5) through the small loop (*a*, Fig. 4), and tie them also tightly, when the ferret is muzzled. Any person may put this on with a little practice, but it requires rather more to use a single piece of whipcord, as the struggles of the ferret have to be overcome. The plan is to slip first a noose over the jaws, then bringing the ends round the neck, they are tied above, and one of the ends being slipped through the string as it lies over the nose, it is tied to the other on the forehead. Net bags are made to take in the whole head, but they hold the claws of the ferret when it attempts to scratch them off, and are not at all useful. Leather muzzles are also sometimes employed, but they do not answer so well as the cord. When the ferrets are thus guarded they are put into the earths, in such a position that the rabbits will be bolted on the other side of a hedge or bank, which must be silently watched by the sportsman, who shoots them as they bolt. But the worst of the plan is, that after the first discharge of the gun the rabbits do not bolt freely, and they are very apt to cause the ferrets to "lie up," even though they are securely muzzled. When this is the case, all that can be done is either to watch patiently till they come out, or to dig them out, which latter plan cannot always be carried out in strong or rocky ground.

THE SHOOTING PONY.

On the moors especially, but sometimes also in partridge shooting, and even in the battue, the shooter prefers four legs to two. This may arise either from inability to walk, or from disinclination, or perhaps from both combined in many instances. Colonel Hawker advised that the sportsman should have a pony calculated to carry double, and that in

this way not only he, but his marker, would be able to get over the ground better than on foot. On the moors, no doubt a bad walker has a poor chance, and as the distance to be got over is very considerable, we can hardly wonder that those gentlemen who only walk should require assistance.

When a pony is used for this purpose, the shot is sometimes taken from his back, but generally speaking, the rider dismounts when his dogs find, and leaves his quadruped to take care of himself while he re-loads. In either case the pony must be carefully broken to stand fire, and he should be also made extremely clever in leaping "in hand," and also in standing without being held wherever he is left. A high-couraged horse will seldom serve the purpose, as he will demand a very long-continued education; nor will the stubborn temper so often displayed among the Welsh galloways be likely to submit to the discipline of the breakers in the implicit manner which is essential to success. But the Highland pony will generally be found to combine the various requisites, and is also instructed by practice in his early life in the treacherous nature of bogs. Nothing is more common on the moors than for a mounted sportsman to get stuck in one of these traps, and if he then is on an animal which is not "up to trap," he will flounder deeper and deeper, and at last perhaps be obliged to call assistance to get himself and his stupid brute out. On the other hand, the Scotch pony may get him into a bog, but then he will stand till his master quietly gets off upon the surface, which will bear the weight of the latter, with the aid of his broader feet, but will allow the more bulky proportions supported upon the smaller pedestals of the pony, to sink through. In selecting ponies for making into shooting cobs, this quality should be taken into consideration, if they are wanted for the moors, but very many are required by the less ambitious partridge shot, who is too unwieldy for the active exercise in any case required in grouse shooting. Generally in the north the pony is only required (except for the lazy and infirm) to take the shooter to the moor; once there, he can scarcely avail himself of his pony's assistance without sacrificing his sport. During the time in which a man is dismounting, the grouse are getting on the run, and the interval, short as it is, will very often enable

them to rise out of shot. Few active men try the experiment, but I fancy if they did, they would find that they could kill more birds with than without a pony. With his aid, you may get up to the birds much more quickly; and I do not think that the noise made by the canter of the pony occasions any disturbance to them. No doubt the increased height is a disadvantage, but to balance this is the increased speed in getting to your dog's point. How often do we see the pointer stand at 150 or 200 yards off, and what a time it takes to get up to him, especially if against the steep side of a hill; on the other hand, many parts of the moors are not rideable. In making the comparison, it is generally the case that the shooter on foot is an active young man, and the pony-man an old and infirm one, who takes five minutes to get off, and perhaps rides up as slowly as the other walks. Still, I should never advise any good walker to adopt the use of the pony, but at the same time, on *most* moors, I fully believe an active, wary man may, if he likes, use one with advantage, and especially when birds are running much. The pony only requires to be broken to stand the gun, to leap in hand, or follow over a fence, and to be handy, and used to stand without holding. All this is so easily taught, that it is unnecessary to allude to it here.

CHAPTER V.

GENERAL MANAGEMENT OF SHOOTING DOGS.

KENNELS AND KENNEL MANAGEMENT—FEEDING—DRESSINGS AND PHYSIC
—PREPARATION FOR WORK—MANAGEMENT AFTER WORK.

KENNELS AND KENNEL MANAGEMENT.

THE KENNELS intended for pointers and setters should be dry and well protected from the weather, but they should be kept cool, on account of the exposure to wet and cold which shooting dogs must incur. This is especially needful with spaniels, who are often wet for hours together in the coldest

days of winter. Some people keep them chained up to a small yard-kennel, similar to that of a watch-dog, but the plan is not a good one, as there is not sufficient exercise taken. In a pointer-kennel there should always be a yard twelve or fourteen feet long, and paved with *hard* bricks, the less porous the better. If, however, it is washed down two or three times a week, there is no necessity for their being glazed. The yard should not be roofed in, as the rain serves to keep the floor sweet, and a little wet only serves to harden these dogs, who will not suffer from it if their beds are dry. An inner or lodging-room must also be provided, and this is better if floored with cemented bricks or asphalt. Nothing is so injurious to the health of dogs as a damp floor, except, perhaps, a dirty one; and as in the case of porous bricks, it must be either one or the other, they should be rejected, or if used, they must be covered with cement. The additional cost of a layer of this material is not great, and for the ordinary size of floor required, it will not exceed ten or twelve shillings. If the cement is carried a foot up the walls, an additional guarantee is afforded against the absorption of urine, and the dogs are rendered all the more healthy at a very slight extra outlay. For the benches, deal laths set pretty close together, answer every purpose, but they should be lined towards the walls, so as to prevent the cold striking into the backs of the dogs. These benches are better not more than a foot from the floor; as if they are higher, some of the dogs are very apt to get under them and become covered with the dirt falling through the interstices of the laths. Ventilation is provided for by having the door always open, but it is as well to have a provision for it in the upper part of the lodging-house. A light should also be provided, though for the same reason it is seldom wanted. In order to keep the yard as sweet as possible, it should have a fall towards the centre, where there should be the trapped grating of a drain to carry off the washings of the yard. Close to this it is a good plan to put up a low post, which will be used by the dogs to lift their legs against, and will thereby save the door-post from constant pollution. Tiles form the best covering for the lodging-room, being warmer in winter and cooler in summer than slate. Thatch is still less influ-

enced by heat and cold, but it harbours fleas and other vermin so much as to be negated on that account. A layer of felt under the tiles is a good addition, but by itself it is so liable to become rotten, that it is not to be recommended.

FEEDING.

All shooting dogs are fed upon oatmeal more or less mixed with other kinds of meal—such as that of barley and Indian corn. It is found that the slightly aperient nature of the oat keeps the dogs in good health, and this meal therefore does not heat them when kept for a time in kennel, as is the case with barley-meal, or Indian corn meal, or wheat flour. If they are regularly exercised, which they ought to be, there is nothing better than a mixture of Indian corn and oatmeal, in such proportions as to keep the dog's bowels gently moved. The foreign meal is somewhat cheaper than oatmeal, and on that account it is used by many people; but unless the precaution is taken to exercise the dogs, it is almost sure to heat them, and produce eruptions of some kind or other. Green vegetables, such as cabbages, cauliflowers, &c., or potatoes, carrots, or turnips, should be added two or three times a week during the summer, dogs being ready enough to eat the mixture if it is flavoured by broth made either of flesh or greaves. Bones also are essential to health, for unless the dog has something to gnaw, he does not produce the amount of saliva which is required for his digestion. With these several elements he may be kept in good health, provided always that he is not exposed to infectious diseases, and is not infested with vermin. Throughout the months when shooting dogs are idle they require no flesh, and their meal need only be flavoured with broth. The materials generally employed for making this are greaves, which being always purchaseable at the chandler's, are on that account very convenient. They are the refuse membranes left after melting fat for candles, and contain some considerable nourishment of a mild nature, though from being stale the smell is strong, and not very appetizing to the stomach of man. The dog, however, is naturally fond of high flavours, and will ravenously devour flesh when it has

been kept till it is high. The usual method of preparation is to break up the greaves, and boil them in water till they are soft, then stir in the oatmeal, and boil for a quarter or half an hour, stirring constantly to prevent burning. Take off the pot, or if in a copper, rake the fire out, and let the whole cool, when it becomes stiff, and is known as "puddings." The quantity of meal necessary for making this varies so much, according to the quality, that no directions can be given, and practice will soon show how much will suffice. Of the greaves a pound per week is plenty for dogs out of work; and of the puddings thus made somewhere about a pound and a half to two pounds will be the average consumption per head daily. I may mention that the puddings should be so stiff as to bear to be cut in masses without losing shape, or sticking to the knife or spade with which this is done. When dogs are hard at work, and indeed, while they are strongly exercised in preparation for it, a little flesh should be given to them; and for this purpose there is nothing better than sound horse-flesh, boiled, and the broth used for the puddings. The change, however, should be gradual, and it is well to give them an occasional meal of it during the summer, to avoid the chance of its disagreeing in the autumn, which it often does when given for the first time.

DRESSING AND PHYSIC.

When dogs are kept long in kennel they are almost sure to contract some eruption of the skin, which is often caused by parasites of one kind or other. Many of these are so minute as to require the microscope to detect, but others are visible to the naked eye. Of the latter kind are fleas, ticks, and lice, which are great pests, and very difficult to exterminate. The usual method adopted is to dress the dogs once or twice in every year, and the dressing adopted is very generally a mixture of train oil and brimstone, which is rubbed into the roots of the hair over the whole body. This answers well enough in killing the vermin above named, none of which can live when covered with oil, but it is very apt to chill the dogs themselves, as the oil has nearly as cooling an effect

upon the skin as water, and we all know that a dog kept wet for days together would be sure to contract some kind of disease. There are several remedies which have no such ill-effect, and for valuable dogs they are well worth the adoption, though attended with some little trouble and expense. But to please all parties, each shall be enumerated in the following list.

A good Dressing.—Take of spirit of turpentine four ounces, train oil twelve ounces, brimstone two ounces ; mix.

To kill Fleas.—Take of soft soap two ounces, carbonate of soda one ounce ; mix, and add a little water to form a paste ; rub this well in to the roots of the hair, let it remain an hour, then wash all out with warm water and dry.

For any Vermin.—Rub Keating's Persian insect destroying powder into the roots of the hair. It is quite innocent in its action on the dog, and kills the insects at once with which it comes in contact.

To kill Ticks or Lice.—Take white precipitate in powder, rub it well into the roots of the hair ; let it remain for two or three hours, keeping the dog carefully muzzled ; then brush all out, and keep the dog dry for some days.

To remove the Ticks from the Walls and Benches.—Take of corrosive sublimate two drachms, sal ammoniac four drachms ; rub together in a mortar, then dissolve in half a gallon of water, and brush the walls and benches over with it, saturating them well. Next day go over them with quicklime wash, to which is added a little size to prevent its coming off afterwards on the dogs' coats.

By adopting any of these measures, kennels may be cleared of all of these vermin, and their denizens also kept free from them. There is no doubt that, by keeping dogs scrupulously clean vermin will not collect at all, but they must be washed once a week in order to ensure this desirable object. During the summer fleas *will* collect upon dogs under any circumstances, especially if they are allowed plenty of litter and it is not frequently changed. There is no necessity for this, for dogs do not care to lie in straw when the weather is warm, but prefer the cool flags or a bare bench, on account of the heat of the litter. Shavings of red deal are also good preventives of fleas, all insects disliking the

turpentine which they contain. But, besides these visible parasites, as I before mentioned, there are other and smaller ones which attack the dog's skin, causing what is popularly called virulent mange. For their removal a dressing is absolutely necessary, and in addition medicine will often be required. Here much depends upon the nature of the parasite, and the extent to which the mange produced by it has gone, but the following applications may be tried, and if one does not succeed the other probably will.

Dressing for Virulent Mange.—Take of compound sulphur ointment four ounces, spirit of turpentine two ounces; mix, and rub well into the skin twice a week. Or, take of iodide of mercury one drachm, lard one ounce; mix, and rub a very little into the roots of the hair every day.

Red mange is a constitutional malady, and can seldom be cured without internal medicine, as indeed is often the case with the virulent form. Arsenic in minute doses, continued for months together, is almost a specific against the foul condition of the blood which exists in either case. It should be given with the food, and not on an empty stomach. For an ordinary pointer, setter, or spaniel, proceed as follows:—

Take of Fowler's solution of arsenic five to eight drops, add to the food, and give twice a day; the dog being fed night and morning. If in a month the whites of the eyes do not become red, increase the dose gradually till they do; then diminish a drop per week till the redness disappears, when continue the dose till the eruption is gone.

Physic is given regularly in some kennels, but this can only be necessary when the dogs have been previously neglected. No care will prevent infectious diseases from entering a kennel, and distemper will revel in it in spite of every precaution. But the physic usually given is not for such diseases as these, but to counteract the effects of too much food, coupled with the omission to exercise the dogs. An occasional dose of castor-oil will certainly do no harm, and indeed the dog is by nature inclined to adopt some such irritating remedy, for the effect of the grass which he eats is nearly the same. If, therefore, a dog becomes dull and devoid of appetite, it is well at all times to give him a dose; but as long as he keeps in health and spirits there is not the slightest

occasion to interfere. An excellent kennel remedy is the following :—Take of castor-oil three parts, syrup of buckthorn two parts, syrup of poppies one part ; mix, and give two tablespoonfuls to a large dog, and in proportion to a smaller one.

Worms are the most troublesome pests of all in every large kennel, for though there are occasional exceptions, the rule is that they exist in every dog during most parts of his life. When in small numbers, and especially if they are only the variety called maw-worms, little injury is done, but tapeworms and round-worms interfere sadly with the health and strength. When, therefore, either of these kinds is found to exist, the remedies proper for their removal should be administered. It is impossible to find space here for a complete treatise on “worms and their removal,” and, indeed, in reference to them as well as to other maladies, the reader should consult those books which are specially devoted to the subject. All that can here be done is to indicate the most simple treatment, preventive as well as curative.

The *cause* of the presence of worms is very mysterious, but of late many discoveries have been made, which tend to show that though only a limited number of species are found in the dog, they are produced from the *ova* of a greater variety of parasites infesting the sheep, the rabbit, and other animals upon the flesh of which the dog is fed. Hence it becomes doubly important that precautions should be taken against the introduction into the stomach of any flesh, paunch, trotters, &c., without boiling, which will destroy the life of these eggs, supposing them to exist. Practically it has long been found that such a proceeding was necessary, and butcher-fed dogs have been always supposed to be peculiarly liable to worms. The *ova* deposited in the bowels of the dog are likewise supposed to be retained in a state of vitality for months and even years, attached to the walls of the kennel, so that it is desirable as far as possible to destroy them in that position, or to avoid keeping dogs year after year in the same building. The latter precaution, however, is a most troublesome one, and few sportsmen will be inclined to build new kennels for their dogs every two or three years. But by using the wash ordered at page 162, for ticks, the

double purpose will be served of destroying them as well as the presumed ova of the parasitical worms. Another preventive is to be found in the preservation of the health of the dog, for if he is kept well, and accustomed to regular exercise in fresh air, his stomach will be so vigorous and the secretions so healthy, that worms will have a hard battle to maintain their existence. Still, in spite of the adoption of all these plans, worms will be found to exist in many dogs, and then they must be removed, or the health will be found to suffer in the course of time.

Whatever remedy is used to destroy worms, it must be of an irritating nature, and those drugs which are fatal to the parasite cannot but be more or less injurious to the animal on which it preys. The choice is therefore to be made of the remedy which is least so, and this is found to be the areca nut. There are also several advantages peculiar to this remedy, such as the absence of any disagreeable taste, and its cheapness. But although the areca nut may be given without any risk worth consideration, it cannot be said to be wholly innocuous, as I have known it produce very severe symptoms in one or two instances; but as these were the only ones out of perhaps tens of thousands in which it has been given, the drug may be said to be a safe one. Powdered glass is equally innocent, but then it is not nearly so effective, and it may, I think, be discarded from use on that account. Turpentine and koussou for tape-worm, and Indian pink for round-worm, are the most potent remedies for these varieties, but they are far from safe, and must be given with caution in all cases. The dose for a pointer, setter, or large spaniel in each case is as follows:—Take of powdered areca nut two drachms; mix with some thick broth, and give it *directly after* mixture to a fasting dog. In six hours follow it up with a dose of oil.—Take of koussou two drachms to three drachms, boiling water half a pint; mix, and when nearly cold, add the juice of half a lemon; then drench the dog after twenty-four hours' fasting. Follow this up also with oil.—Take of spirit of turpentine two drachms to four drachms; tie it up in a piece of bladder, and give as a bolus. Four hours afterwards, let the dog have half a pint of broth, in which is stirred up a tablespoonful of castor-oil.—Take of Indian

pink two drachms, boiling water four ounces; mix, and let it stand till cold, then pour off the infusion, and give as a drench.

PREPARATION FOR WORK.

Until the shooting season the dogs are too apt to be neglected, and are often left in kennel for weeks and even months at a time. When this is allowed they become fat, inside and out, and they are not able to work for want of muscular power and wind, as well as from the tenderness to which the feet are subject. Without constant use all the organs of the body become inefficient, and this is more particularly the case with the muscular system. The shooter is well aware of this fact, as exhibited in his own person, and yet he will often ignore it as concerns the inmates of his kennel. He should remember that the pointer travels over six times the ground which he does, and at a fast pace, instead of a walk. But the experienced sportsman is well aware of the necessity of preparation in the case of his dogs, and for at least a month before they will be wanted he sends them to exercise daily. Even this time is not long enough if they have been confined throughout the summer, for though their muscles and wind may be got right in that time, their feet will not be sufficiently hardened. It is in this part that dogs generally fail, and to keep them hard and tough throughout the month of September, in a dry season, they must have been regularly inured to the road by a good run on it once a week, at least, all through the summer. The horny matter which covers the pads inevitably wears away in work, and if it is not rapidly formed again, the foot becomes tender and the dog is lamed. A habit of quick growth in this part is therefore essential, and this is produced by constant friction. Some dogs naturally have thin soles, but even these may be made thicker by use; while the strong, horny pad may be rendered perfectly invulnerable. Let every shooter see that these precautions are used, and he will not suffer from the disappointments which are so frequent, owing to their neglect. Many a mistake is caused by want of condition, and not from want of nose, for a blown and exhausted animal is not in possession of the sense of smell.

MANAGEMENT AFTER WORK.

Pointers and setters, as well as spaniels, often come home in a state of great exhaustion, partly caused by exposure to cold and wet. In this state they are very liable to congestion of some internal organ, and great numbers every year die of "the yellows" in consequence. When a valuable animal is in this state, with cold legs, ears, and feet, a dry nose, and a look of exhaustion, he should be put into a warm bath and kept there for a quarter of an hour. Just before immersion in it, if he is in a very low state, give him a little spirit and water as a drench, and after he comes out rub him dry, finishing up with a glass of spirit (whisky or brandy), rubbed into his back and sides. Then feed, or if the dog refuses this, drench him with a teacupful of good broth, or of gruel with a little brandy in it. Afterwards let him be put by himself in a moderately warm stable or kennel, with plenty of clean straw in which he can roll himself. Should these measures not be sufficient, recourse must be had to veterinary assistance.

When *sore feet* are produced by neglect of preparation, they should be soaked in hot water by placing the dog up to his knees in a tub, or a couple of pans if a tub large enough to hold all four is not at hand. A tablespoonful of salt and powdered alum may be added to the water with advantage, unless the pads are absolutely raw, when they are better omitted. After taking the feet out, dry them thoroughly with a cloth, and then dress them with tar ointment. Apply a little of this every six hours, and in a short time the tenderness will disappear; but it takes a long time, if the dog has not been used to hard ground, before the horny sole is restored in sufficient thickness to bear work.

BOOK III.

ELEMENTARY PRINCIPLES OF GUNNERY, AND COMPOSITION OF THE PARTS ESSENTIAL TO IT.

CHAPTER I.

DEFINITION OF GUNNERY AND GUNS AS APPLIED TO SPORTING PURPOSES.

GUNNERY IN THE NINETEENTH CENTURY AS APPLICABLE TO SPORTING PURPOSES—CLASSIFICATION OF MODERN GUNS AND RIFLES—SHOT GUNS CONSIST OF A TUBE MORE OR LESS CYLINDRO-CONOIDAL, CAPABLE OF BEING CLOSED AT ONE END—BARRELS—LOCKS—MODES OF EXPLODING—THE DESIDERATA IN THE SHOT-GUN—THE RIFLE.

GUNNERY IN THE NINETEENTH CENTURY AS APPLICABLE TO SPORTING PURPOSES.

It does not come within the scope of this work to enter upon the history of projectiles from the earliest times, a subject which interests greatly the mechanic and the antiquary, but is not always approved of by the sportsman. Nor is it necessary to enter upon a description of great guns, which are used only in war, or upon military small arms, those with which the sportsman operates being called "bird guns" in the trade, in contradistinction to "small arms," which is a military term. The principle is, however, in all cases the same, that is to say, a sudden impulse is given to a body previously at rest, and in such a way as to drive it forcibly in the direction of the object which is to be struck. In the arrow and the bird-bolt used with the bow or crossbow, this impulse is communicated by the string on its release from a notch which has held it behind the arrow or bolt until it is

let go. The string itself, however, is only the passive agent, the active power residing in the bow. This has an elastic property inherent to it by which it strives to resume its original position when it has been drawn from it. So again in the air-gun, ordinary atmospheric air is compressed by a pump, and its elastic property induces its expansion when the pressure is taken off. In both these cases, then, we have a previous compression of an elastic agent, the release of which causes an impulse to be given to the projectile in front of it. In gunnery, however, the elastic agent is *naturally* compressed into a small space, and when confined in a chamber open in one direction only, and made to expand by ignition, its elastic power is so great as to give a far greater impulse to any body impeding its expansion, than either the bow or compressed air. In the present century, therefore, advantage is taken of this natural agent, and whether in the shape of gunpowder, guncotton, or any other still more active material, in all cases there is an extraordinary impulse communicated to some projectile which is placed between one or other of these, and the only passage by which the elastic gas resulting from the explosion can escape.

The *conditions at present essential* to our branch of gunnery are, first, the existence of a tube of iron capable of being closed at one end, with the exception of a small opening for firing its contents. Within this and at the closed end is a charge of some explosive matter, which may be either gunpowder or guncotton, or any other agent, provided that it will suddenly expand to a sufficient extent when fired by contact with a burning substance. Between this and the muzzle is the projectile, which may consist of one mass of lead or of many smaller ones (in the latter case being called shot), which by the sudden explosion of the powder or cotton is driven in the direction of the long axis of the tube, with a tendency to fall to the earth as it progresses, in conformity with the law of gravitation.

CLASSIFICATION OF MODERN GUNS AND RIFLES.

All guns, therefore, consist of a tube more or less cylindrical-conoidal, closed at one end, with the exception of a small

firing-hole, and either smooth in the interior, or if great accuracy is required, when intended to be used with ball, grooved in a spiral direction. Here, then, we have one great subdivision into smooth bores and rifles, the former being used with shot or ball, while the latter is intended for ball only. But in addition to this subdivision, we have also another most important one, and gradually becoming more so every year. This consists in the method of putting in the charge, which may be either at the muzzle, and the guns are then called muzzle-loaders, or at the breech, when they are denominated breech-loaders.

SHOT-GUNS CONSIST OF A TUBE MORE OR LESS CYLINDRO-
CONOIDAL, CLOSED AT ONE END.

Whatever may be the method of firing and loading adopted, every shot-gun is composed of a tube of iron, bored so as to represent a cylinder in the greater part of its extent, but more or less conical in the remainder. One end is left open, to allow of the shot escaping when the explosion behind it takes place; the other is closed either by a plug of iron being screwed into it, as in the ordinary muzzle-loader, or by some method to supply the place of this solid breeching, after the charge is introduced at the breech end. Besides the cylinder or barrel, as it is called, there is also a provision for the explosion of the powder, which is effected in different ways, according to the kind of gun which is to be employed. Lastly, the barrels must be made capable of being handled quickly, and applied to the eye so as to get a "sight" of the object against which they are to be directed, and for this purpose a wooden handle called a "stock" is provided, so shaped as to be adapted to the individual for whom it is intended. Here, then, we have the gun divided into the *barrel*, which is the essential part, the *lock* which provides for the firing of its charge, and the *stock* which is added to attach these two together, and also to allow of the adjustment of the barrel in a straight line with the mark to be hit.

In the early part of this century, and during the whole of the last, the gun used for sporting purposes was that known

as the flint-gun. This was a similar tube to that now used, as far as its principle of action is concerned, with the exception that the charge was fired by means of a spark (arising from the striking together of flint and steel), which fell into a small cup of powder outside the barrel, but communicating with its interior through a small canal (the touch-hole) also filled with gunpowder. By means of this comparatively rude invention, the sportsmen of that day were able to shoot flying, but not with the same accuracy as at present; and the practice required to make a "good shot" was ten times as great as with the percussion gun. The explosion was much longer about, and the aim was consequently behind the object, unless allowance was made for the loss of time, which would necessarily vary greatly according to distance. The same principle of allowing for loss of time is still required, but this is now so trifling, that by aiming at a hare's head, the shoulder will be struck, and the same proportion will hold good with flying objects.

BARRELS.

Though the barrels of all guns and rifles are of iron, they are not all made in the same way, or of material corresponding in strength. In the infancy of the art, a flat piece, or sometimes two pieces of iron, were welded longitudinally round a mandril into a tube, but in process of time it was discovered that by twisting narrow strips of iron spirally round, and welding these together, a much stronger tube was produced with less metal. This plan is therefore adopted in the present day in all the best guns, and in rifles where weight is objectionable. In these latter guns, however, a solid bar of steel is sometimes perforated and grooved, but weight for weight it will not compete with the twisted barrel.

THE GAUGE.

All guns are measured according to their diameter, which is technically called the gauge or calibre. There are two ways of estimating this, first according to the weight of a spherical leaden ball which will fit the gauge, and secondly, according to the diameter in decimal parts of an inch.

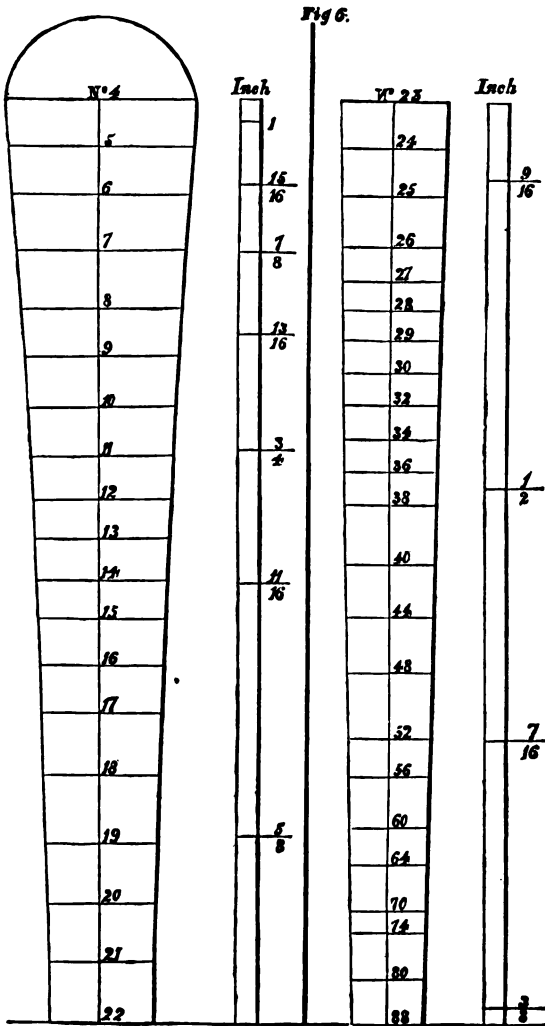

The former is always adopted with shot-guns and sporting rifles, while the latter is generally applied to military arms. Thus a gun of 12 gauge carries a ball weighing the twelfth part of a pound avoirdupois; a 14 gauge carries one of fourteen to the pound, and so on. For sporting purposes, shot-guns are now generally made of 12 or 14 bore; but where great lightness is required, 16 or 18 even may be adopted. These gauges measure severally in inches or parts of an inch, as shown in the opposite table:—

It is therefore easy for any one knowing the gauge of his gun or rifle to get an approximate idea of its diameter in inches; and on the other hand, if the diameter is known in inches, a sufficiently accurate guess for practical purposes may be made at its gauge, or in other words, at the weight of the *spherical* ball which it will carry. The diameter of the intermediate gauges is not exactly in proportion to those above and below, as the scale between 4 and 16 does not descend in a straight line, but in a slightly concave one. Without actual measurement, therefore, the precise diameter in decimal parts of an inch cannot be given, but for practical purposes the fractional parts here introduced are sufficient.

LOCKS.

The *first spring locks* for the use of the flint-gun were made in the beginning of the sixteenth century, but they were rude in the extreme, and though they effected the discharge of the gun, they took their time to do it. Previously to this, the powder was exploded by a match, which would forbid the use of the barrel except towards sitting objects. The spring flint-lock was therefore a considerable step, and by the aid of various clever inventors, it was brought to great perfection. Indeed, so useful and deadly was the flint-gun in the time of the Mantons, that they were long before they could be induced to adopt the next invention, to which we are now indebted for the quick shooting which all our modern kinds give. This was the discovery of the mode of firing gunpowder by exploding close to it a small quantity of a composition which would take fire on being sharply struck with a hard body. From this circumstance the plan was called the per-

percussion principle, although the flint equally requires percussion with the steel to elicit the spark which drops into the powder and ignites it. But in the former case there is no necessity for an external reservoir of powder, and the blow of the hammer is more evidently the cause of the explosion; so that though there is no great difference between the principles of the two methods, it is apparently very considerable, and in practice it really is so. But whether the name is correctly given or not, the plan was introduced, and is now universally employed, a flint-gun in the present day being only occasionally kept as a curiosity, and an order for one being as great a rarity as the Koh-i-noor.

The *Forsyth* lock, which was the first on the percussion principle, was brought out by its inventor, a clergyman, resident at Bethelvie, under very good patronage, and with high-sounding pretensions. An advertisement announced to the world that a gun had been invented which went off without flash or smoke, and that consequently "flash in the pans" would be hereafter unknown. Now, every sportsman up to that time was constantly annoyed by these little accidents, and therefore the novelty was accepted by all but those bigoted to old-fashioned ways, simply because they are old, as a step in the right direction. The plan was proposed soon after the discovery of the new fulminating powders, which are now so well known, and it was used by means of a small magazine which held enough powder to effect thirty discharges. But in practice it was open to the objection that sometimes the quantity was too small, and at others the whole of it contained in the magazine exploded; again, the tube leading to the powder was small and with a sharp angle in it, so that misfires were almost as common as with the old flint lock.

MODES OF EXPLODING.

The *Invention of the Percussion Cap* has been the greatest improvement in firearms during the present century; for, though it is not outwardly apparent, yet in almost every variety of shot-gun or rifle it is now employed in some shape or other. Lancaster's needle-gun, it is true, has no

cap, and Sharp's rifle also is without one; but in each case a copper disk is substituted for it, and as there is merely an alteration of form, they can scarcely be said to be exceptions.

We may, therefore, assume that in all cases our modern guns are made so that the charge is exploded by means of a cap or disk containing fulminating powder, and exploded by means of percussion. In this point, therefore, there is little difference to be found in the principle adopted, and we must look further to discover the particular element in which the various guns now in use differ from each other. We find them to consist chiefly of, first, the original percussion gun, which has been in general use among sportsmen for about forty years; secondly, of the French crutch gun, introduced into England within the last four or five years, but known on the Continent for about twenty years; thirdly, of Lancaster's additions to this; and fourthly, of Needham's needle-gun. There are minor points of difference adopted by gun-makers in the two first divisions; but the two last, being patented by their respective inventors, are each of one pattern only. Now, among all these four the barrel is nearly the same, and the charge is fired by means of a percussion cap or disk; but, while in the first this charge is introduced by the muzzle, in all the three last the breech is opened for its insertion and then closed again by a mechanical contrivance. Hence, in the list of the various shot-guns of the present day, a distinction is now made between muzzle-loaders and breech-loaders, and these must be separately examined before their merits can be compared, with a view to ascertain how nearly each of them comes to the standard of efficiency which is desired. In order to ascertain what that is, we must first consider what are

THE DESIDERATA IN THE SHOT-GUN.

It is found by experience, as far as our present knowledge goes, that a gun can only be made to combine a certain amount of strength with regularity of pattern. By a particular method of boring its cylinder, it is comparatively easy to obtain either of these objects, but the other cannot be added without a sacrifice of the first in some degree.

Hence it is the practice of our best makers to bore their guns so that at from forty to sixty yards they shall give such a pattern on the target as will prevent the escape of a partridge or grouse, and at the same time drive their shot with as much force as possible. These two points may, therefore, be considered as the two essentials; and, in addition, it is considered desirable to avoid encumbering the sportsman with a tool which shall be too heavy for him to carry without fatigue, or, with one whose recoil shall be unpleasant to him from its severity. A practical man knows that a heavy gun shoots better than a light one, and that the recoil must to a certain extent be in proportion to the force with which the charge is driven forwards; but he also knows that either one which is too heavy, or which recoils too much, even if its shooting is very good, is wholly useless to most sportsmen. He therefore endeavours to make his guns with the following good qualities, which are those that are generally regarded as the requisites for a shotgun. These are, first, a good pattern on the target made by them at forty and sixty yards; secondly, as much force in driving the shot as possible, in combination with the first quality; thirdly, lightness as far as is compatible with safety and good shooting; and fourthly, the absence of such recoil as is unpleasant to the shooter.

Every gun may, of course, be made clumsily or the reverse, but the maker who does not turn out his productions in a workmanlike manner must be rejected on that account, since there is no excuse for him in this respect. All should be well balanced and the parts accurately fitted together, while the mechanism of the locks, &c., should be of the most highly-finished kind consistent with the price. A cheap gun may shoot strongly and make a good pattern, but its parts will be seen to fit badly and its locks will be sure to be faulty. Hence it soon wears out, and, in addition to its want of safety, it will generally be found to be the dearest in the end. By the word *cheap* I mean the opposite extreme to the high price which is charged by our fashionable makers, and not the medium charge made by our best provincial gun-makers, who are content with profits which would not support the expensive establishments of some London makers. It is

essential to the safety of the sportsman that he should select a tradesman who has a character to lose, and who is not driven by necessity to risk the lives of his customers by underselling his rivals. On this point every man of any prudence will take care to protect himself; but if he will only be guided by the rules of common sense, and by his practical knowledge of human nature, he is just as likely to be furnished with a safe gun, and a good shooting one too, at one-fourth below the top price, as if he paid that sum to one of the most fashionable makers of the day.

The final boring of a gun—that is to say, the operation which determines the exact shape of its interior, will vary greatly according to the materials and shape of its breech, and to the length of the barrel. None are made of a truly cylindrical shape, and it is usual to “open” or “relieve” them, or sometimes both processes are adopted. By opening is to be understood the formation of a slight cone with its base at the breech; and by relieving, the production of a cone with its base at the muzzle. The exact proportion of these parts is, however, one of the secrets of trade, and almost every gunmaker professes to have a plan of his own, which he considers superior to all others. The old flint gun was both opened and relieved; the detonator is generally also slightly opened; but a considerable degree of this causes a good deal of recoil, and some makers only relieve their guns. I believe that there is no absolute certainty in the practice of boring, and that in almost every case some attention will be required after trial. This is what is called “regulating” the gun, and hence we so constantly see gunmakers shooting at an iron plate to enable them to ascertain what is to be remedied. If the gun spreads too wide it is relieved, while if it has not driving power enough, it is opened till it performs to the satisfaction of the trier.

The *rifle* consists of an iron or steel tube similar in its external form to that of the shot-gun, but grooved internally in a spiral direction, so as to make the ball which it carries revolve or spin around the long axis of the barrel when continued forwards. These grooves may be narrow or wide, deep or shallow, and of any number from two upwards. In the oval-bore, as it is called, the rifle appears at first sight to

be similar to a smooth bore, but it really is merely a two-grooved rifle with the edges of the grooves rounded off. It is unnecessary, however, here to go into the details of these different methods of grooving, which will be found fully described in the Fifth Book.

CHAPTER II.

ON THE ACTION OF GUNPOWDER AND OTHER EXPLOSIVE COMPOUNDS.

GENERAL REMARKS—ACTION OF THE POWDER ON THE PROJECTILE—
MODE OF DETERMINING ITS VELOCITY—EPROUVETTES—RESISTANCE
TO THE MOTION OF PROJECTILES THROUGH THE AIR—RECOIL—
COMPOSITION OF GUNPOWDER AND GUN-COTTON, AND THE MATERIALS
USED FOR FIRING THEM BY PERCUSSION.

ALTHOUGH much has been done within the last few years in improving the machinery by which bodies are projected through the air, yet little has been discovered since the days of Robins and Hutton, in reference to the principles upon which they act. Indeed many so-called novelties of 1858 and 59 are merely old inventions warmed up, and this is more especially the case with regard to Mr. Lancaster's oval bore, which was described in the clearest language in the year 1808, as will be fully shown in the proper place. The following propositions are chiefly taken from the pages of the celebrated Robins, who is still accepted as the highest authority on the subject.

Gunpowder when exploded produces a permanently Elastic Fluid.—If, says Robins, a red-hot iron be included in a receiver, and the receiver be exhausted, and gunpowder be then let fall on the iron, the powder will take fire, and the mercurial gauge will suddenly descend upon the explosion; and though it immediately ascends again, yet it will never rise to the height it stood at before, but will continue depressed in proportion to the quantity of powder which was let fall. The same fact may be shown when gun-

powder is fired under the ordinary pressure of the air, as for instance in a glass tube, the mouth of which is immersed in water, leaving only space enough for the powder at the top. If in this state the powder is fired either by a burning-glass or by galvanism, it will be found to displace water to the extent of nearly two hundred and fifty times its bulk, and as soon as the gas produced by the explosion cools to the temperature of the surrounding air it ceases to contract, and remains a permanently elastic fluid.

Modes of determining the Quantity of this Elastic Fluid produced from the Explosion of a given Quantity of Gunpowder. — Different qualities of powder produce different quantities of gas, and therefore in any calculations which are made public, it is necessary to specify the powder which has been used. Most of that sold now is probably far superior to the powder with which Robins made his experiments; but, nevertheless, they approximate to the truth sufficiently for our purpose. He used the Government powder of his day, which was, I have reason to believe, not within thirty per cent. of the strength of the Government powder of 1859. He says that "1 drachm of powder avoirdupois, on explosion, sinks the mercurial gauge 2 inches; and the mercury in the barometer standing at near 30 inches, 15 drachms avoirdupois, or 410 grains troy, would have filled the receiver with a fluid whose elasticity would have been equal to the whole pressure of the atmosphere, or the same with the elasticity of the air we breathe; and the contents of the receiver being about 520 cubic inches, it follows that 15 drachms of powder will produce 520 cubic inches of a fluid possessing the same degree of elasticity with common air; whence an ounce of powder will produce near 555 cubic inches of such a fluid."

But in order to ascertain the density of this fluid, we must consider what part of its elasticity at the time of this experiment was owing to the heat it received from the included hot iron and the warm receiver, and this is estimated by Robins at about one-fifth of the whole, which brings 555 down to 444. And this last number represents the cubic inches of elastic fluid, equal in density and elasticity with common air, which are produced from the explosion of 1 ounce of powder; the weight of which quantity of fluid, according to

the usual estimation of the weight of air, is 131 grains. If the ratio of the *bulk* of the gunpowder to the bulk of this fluid is wanted, it will be determined by knowing that 17 drachms of powder fill 2 cubic inches; so that, proportioning the one to the other, it will be found that 472 cubic inches of elastic fluid are obtained from 2 cubic inches of powder.

But the amount of gas given off from a fixed quantity of powder is not always a test of its utility in throwing projectiles. Thus many explosive powders, such as fulminating silver and mercury, generate a much greater proportion of gas and far more rapidly than ordinary gunpowder; but the explosion being too sudden, they have not so good an effect upon the projectile in proportion to the power which they exert, and which, from its great suddenness, is apt to burst the tube in which it is contained. Up to the present time two substances only have been found which combine the exact properties required, and these are gunpowder and gun-cotton. In experimenting on different kinds of gunpowder, with a view to determine the relative powers of each, it is found that the density of the air has no effect whatever, but in proportion to its dryness will the elastic force of the powder be exerted. This is very important to know, for it very often happens that powder which has been used on a damp day with less effect than other powder tried in dry weather, loses credit, although, perhaps, really equal, or even superior to the antagonistic material. So also powder which is rendered damp by being poured down a foul barrel is weakened greatly in its effects; and here again is another element which must be taken into the account. In all trials of gunpowder, therefore, dry days should be selected.

ACTION OF THE POWDER ON THE PROJECTILE.

The action of the powder on the projectile ceases as soon as the latter escapes from the barrel. This fact is capable of demonstration mathematically; but as it is not disputed, I shall not go into the calculation. But there is another theory propounded by Robins on this subject which demands a little consideration, because it is contrary to the opinions of most other writers, and was subsequently modified by himself. He asserts, in his earlier writings, *that all the powder in the*

charge is fired and converted into an elastic fluid, before the bullet (or charge of shot) is sensibly moved from its place. This proposition he attempts to demonstrate as follows:—

“ It might perhaps be sufficient for the proof of this position to observe the prodigious compression of the flame in the chamber of the piece. Those who will attend to this circumstance, and to the easy passage of the flame through the intervals of the grains, may soon satisfy themselves that no one grain contained in that chamber can continue for any time uninflamed when thus surrounded and violently pressed by so active a fire. However, not to rely on a mere speculation on a point of so much consequence, I considered that if part only of the powder is fired, and that successively, then by laying a greater weight before the charge (suppose two or three bullets instead of one), a greater quantity of powder would necessarily be fired, since a heavier weight would be a longer time in passing through the barrel. Whence it should follow that two or three bullets would be impelled by a much greater force than one only. But the contrary of this appears by experiment, for firing one, two, and three bullets laid contiguous to each other, with the same charge respectively, I have found (by a method to be mentioned hereafter) that their velocities were not much different from the reciprocal of the subduplicate of their quantities of matter; that is, if a given charge will communicate to one bullet a velocity of 1700 feet in 1", the same charge would communicate to two bullets a velocity from 1250 to 1300 feet in 1", and to three bullets a velocity from 1050 to 1100 feet in 1". From hence it appears that, whether the piece be loaded with a greater or less weight of bullet, the action of the powder is nearly the same, since all mathematicians know that, if bodies containing different quantities of matter are successively impelled through the same space by the same power, acting with a determined force at each point of that space, then the velocities given to those different bodies will be reciprocally on the subduplicate ratio of their quantities of matter. The excess of the velocities of the two and three bullets above what they should have been by this rule (namely, 1200 and 980 each in 1"), does doubtless arise from the flame, which, escaping by the side of the first bullet, acts on the surface of the second and

third. Now, this excess has in many experiments been imperceptible, and the velocities have been reciprocally on the subduplicate ratios of the number of bullets to sufficient exactness; and where this error has been the greater, it has never arisen to an eighth part of the whole; but if the common opinion was true, that a small part only of the powder fires at first, and other parts of it successively, as the bullet passes through the barrel, and that a considerable part of it is often blown out of the piece without firing at all; then the velocity which three bullets received from the explosion ought to have been much greater than we have ever found it to be, since the time of the passage of three bullets through the barrel being nearly double the time in which one passes, it should happen, according to this vulgar supposition, that in a double time a much greater quantity of the powder should be fired, and consequently a greater force should have been produced, than what acted on the single bullet only, contrary to all our experiments. But further, the truth of the second postulate will be more fully evinced when it shall appear, as it will hereafter, that the rules founded on this supposition ascertain the velocities of bullets impelled by powder to the same exactness when they are acted on through a barrel of four inches in length only, as when they are discharged from one of four feet."—Robins's *New Principles of Gunnery*, pp. 80–82.

Now all the facts here adduced may, and I believe are, correctly stated, and yet they do not prove the proposition with which this ingenious author sets out. Moreover, the difference which he explains by supposing that the flame escapes by the side of the first bullet, may far more readily be understood to be in consequence of the increased time which the powder is allowed for explosion. The counter argument may more readily be supported by extending the charge of powder, by loading a small tube several inches in length with it, when the grains in front are evidently blown out in an entire state, proving that there is a point beyond which instantaneous explosion does not go. All that Robins shows by this experiment is, that the charge of powder which he used burns entirely before the one ball leaves the muzzle; and, if that is the case, it can do no more if one or

even two other balls are added. It is now generally admitted, in accordance with the experiments made by a committee of the Royal Society in 1742, that Robins was wrong in his theory on this point; and not only is it shown that the combustion of all the grains in a charge of powder is not simultaneous, but it is pretty well ascertained that coarse-grained powder burns more slowly than fine, and for that reason it is preferred for mining charges. Indeed, so satisfied are practical miners of the importance of slow combustion, that they mix sawdust with their powder, for the purpose of producing it. In the old flint gun combustion was too slow, and for that reason very fine powder answered the best; but in detonators a coarser grain is preferred, and in needle-guns, or in those cartridges when the cap itself is introduced into the charge of powder, a coarser grain still is adopted. By the use of coarse powder, also, the projectile in front of it being more gradually moved, the recoil is diminished, and thereby a larger quantity can be used with comfort to the shooter and safety to his barrels.

MODE OF DETERMINING THE VELOCITY OF THE PROJECTILE.

In order to determine the velocity with which a ball moves at any distance from the piece, a simple plan, now commonly known as the ballistic pendulum, was invented by Robins, and has never yet been improved upon, though, from the difficulty of hitting its centre, it can only be used at short ranges. A square plate of iron faced with wood (Fig. 7, *a*) is suspended like a pendulum from a tripod; and to the lower part of two of the legs of this a cross bar (*b*) is attached. Then fixing a piece of tape to the lower edge of the pendulum, and letting it slide through a notch in a brass plate fixed upon the cross bar, the extent to which the pendulum, when struck by the ball, draws the tape, shows the force of the blow, and the velocity

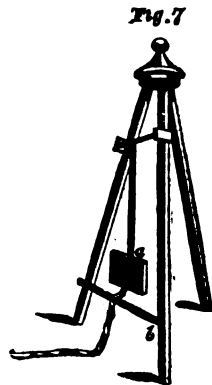

with which the ball has travelled. As Robins remarks, "This instrument thus fitted, if the weight of the pendulum be known, and likewise the respective distances of its centre of gravity, and of its centre of oscillation from its axis of suspension, it will thence be known what motion will be communicated to this pendulum by the percussion of a body of a known weight, moving with a known degree of celerity, and striking it at a given point; that is, if the pendulum be supposed at rest before the percussion, it will be known what vibration it ought to make in consequence of such a determined blow; and, on the contrary, if the pendulum, being at rest, is struck by a body of a known weight, and the vibration which the pendulum makes after the blow is known, the velocity of the striking body may from thence be determined. . . . The computation by which the velocity of the ball is determined from the vibration of the pendulum after the stroke requires a more particular explication; and for this purpose we will exhibit, as an example, the pendulum made use of by us in some of our experiments. The weight of the whole pendulum was 56lbs. 3oz.; its centre of gravity was 52 inches distant from its axis of suspension, and 200 of its small swings were performed in the time of 253 seconds; whence its centre of oscillation is $62\frac{3}{4}$ inches distant from that axis. In the compound ratio of 66 to $62\frac{3}{4}$ and 66 to 52, take the quantity of matter of the pendulum to a fourth quantity, which will be 42lbs. $\frac{1}{2}$ oz. Now geometers will know that, if the blow be struck in the centre of the plate (*a*), the pendulum will resent the stroke, as if this last quantity of matter only (42lbs. $\frac{1}{2}$ oz.) was concentrated in that point, and the rest of the pendulum was taken away; whence, supposing the weight of the bullet impinging on that point to be the twelfth of a pound, or the $\frac{1}{12}$ of this quantity of matter nearly, the velocity of the point of oscillation after the stroke will, by the laws observed in the congress of such bodies as rebound not from each other, be the $\frac{1}{5}$ of the velocity the bullet moved with before the stroke; whence the velocity of this point of oscillation being ascertained, that, multiplied by 505, will give the velocity with which the ball impinged.

"But the velocity of the point of oscillation after the

stroke is easily deduced from the chord of the arch, through which it ascends by the blow; for it is a well-known proposition, that all pendulous bodies ascend to the same height by their vibratory motion, as they would do if they were projected directly upwards from their lowest point with the same velocity they have in that point; wherefore, if the versed sine of the ascending arch be found (which is easily determined, from the chord and radius being given), this versed sine is the perpendicular height to which a body projected upwards with the velocity of the point of oscillation would arise; and consequently what that velocity is can be easily computed by the common theory of falling bodies.

“To determine the velocity with which the bullet impinged on the centre of the wood, when the chord of the arch described by the ascent of the pendulum, in consequence of the blow, was $17\frac{1}{2}$ inches as measured on the ribbon, no more is necessary than to multiply $3\frac{1}{4}$ by 505, and the resulting number (1641) will be the feet which the bullet would describe in 1" if it moved with the velocity it had at the moment of its percussion. The velocity of the foot of the pendulum on which the bullet struck is determined to be $3\frac{1}{4}$ feet in 1" by the following calculation:—The distance of the ribbon from the axis of suspension being $71\frac{1}{8}$ inches, reduce $17\frac{1}{2}$ in the ratio of $71\frac{1}{8}$ to 66; the resulting number, which is nearly 16 inches, will be the chord of the arch through which the centre of the plate ascended after the strike: now, the versed sine of an arch whose chord is 16 inches and its radius 66 inches, is 1.93939; and the velocity which would carry a body to this height, or, which is the same thing, what a body would acquire by descending through this space, is nearly that of $3\frac{1}{4}$ feet in 1".”

Velocity, or its equivalent, *penetration*, is measured by English military authorities in a much more practical manner, but at the same time, in a way which is open to serious objections, as will be hereafter shown. Their machine is composed of a series of twenty elm planks half an inch thick, with an inch between them. These are made to slide into the grooves of a metal frame, and after being soaked in

water, the rifles to be tried are fired at them from a distance usually of 200 yards, the penetration being estimated by the number of planks pierced. Three rounds are fired from each rifle, and the average of the three shots is taken to be the penetrating power of that particular rifle. The force of different kinds of gunpowder is estimated in the same way, using one rifle and similar bullets and charges of powder. The machine for private purposes may be made entirely of wood, and is then within the reach of every sportsman; but the elm boards of course require constant renewal as they are shot to pieces. In trying these experiments, the result should be recorded in a tabular form, as follows:—

—	—	1	2	3	4	5	6	7	8	9	10	11	12	13	14	15	16	17	18	19	20
Aug. 8th, 1859, fine clear day, no wind.	Enfield rifle, Charge $2\frac{1}{2}$ drs., C. & H. Pritchett ball, 520 grs., fired from the rest.																				

Which will always give the result at one glance, without the necessity for a written description. In the military trials the amount of perforation, if any, in the last board is also expressed in tenths:—thus, first shot, 13·1; second shot, 12·4; third shot, 14·1—average, 13·2.

EPROUVETTES.

The above are the most correct modes of estimating the explosive force of powder, but the former is seldom used, on account of the complicated nature of the calculations required, and of the necessity for the impingement of the ball upon the

proper centre of gravity of the pendulum. In common practice various contrivances, called *eprouvettes*, are employed. One of these consists of a small pistol with the muzzle closed by a valve, acted on by a spring. This valve is in connexion with a ratchet-wheel, which marks the extent to which it is opened by the explosion of the powder, but the spring varying in strength, the test is imperfect. The ordinary plan adopted by large sellers and purchasers is to load a small mortar with a given weight of powder, and then a ball, being accurately ground to fit it, in proportion to the strength of the powder will be the distance to which the ball is thrown. The *eprouvette* of the French Government is a small mortar capable of containing three ounces of powder, and this is expected to throw a copper ball of sixty pounds weight 300 feet. Sometimes the amount of recoil is made the test, and then a little mortar is suspended and loaded with ball, when the extent of the arc of the circle which it describes marks the strength of the powder.

RESISTANCE TO THE MOTION OF PROJECTILES THROUGH THE AIR.

In a state of rest the air offers considerable resistance to the passage of balls and shot through it, and when moving in a direction different from that of the course of either, it is still more perceptible. It is calculated that this resistance increases nearly in a duplicate proportion to the velocity of the resisted body; that is, it is four times as much when the resisted body moves with twice the velocity; nine times as much when it moves with three times the velocity, and so on. In addition to this resistance there is also the force of gravity constantly tending to bring the body towards the centre of the earth.

ON RECOIL.

The expansion of gunpowder when converted into gas being in all directions, it follows that at the moment of firing a blow is given to the breech end of the gun equal to that on the projectile which is to be moved. In proportion to the difficulty of moving the charge up the barrel will this force

be continuously exerted, so that a large charge of powder exploded, with a light bullet in front of it, will exert less force upon the breech end of the gun, than a smaller charge of powder used to move a larger and heavier ball. So, also, the recoil varies with the same charge when the barrel is held horizontally, and when the muzzle is raised or depressed, being increased in the former position and diminished in the latter, in accordance with the laws of gravity. In shooting from the shoulder, the recoil is apparently increased still more than is really the case when the muzzle is pointed directly upwards, because the body cannot yield as it can do when the butt of the gun is held against the muscles of the chest and arm in a horizontal position. Again, in proportion to the weight of the whole piece will the recoil be affected, because a force which will move a body six pounds in weight readily enough will not have the same effect on one of nine pounds or more, having, in the language of science, to overcome a greater degree of *vis inertiae*. Hold a heavy piece of wood or iron in the hand and a severe blow on it will not be felt, while the same, or even a much less force on a much lighter piece would occasion considerable punishment. This fact is well known to all those who have had any experience with guns; and hence it has been considered necessary, independently of the question of safety, to have all guns made of sufficient weight to give the *vis inertiae* required. It will be found that in proportion to the resistance offered by the shot or ball, and to the weight of the whole gun, and more especially at the breech, will be the recoil, but the former is not to be measured by its weight alone, being affected by the friction between it and the barrel. A highly polished surface has a tendency to diminish it, and, on the contrary, a rough one increases it. So, also, if the charge has to be driven through a smaller opening, as in barrels opened behind, the resistance is increased. Again, an ounce of lead causes a much greater amount of friction in proportion to the number of pellets into which it is divided, a single spherical ball producing the least, and dust-shot the most friction of all. On this subject I cannot do better than to give *in extenso*, as far as this point is concerned, a most interesting letter, by Mr. Boucher, which appeared in the

Field on the 5th of June, 1858, in support of some previous statements of opinion made by me on the same side of the argument. He says:—

“Being one of those who deny that great recoil in the gun is any test whatever of great velocity in the shot, I beg to offer a few practical remarks in support of my opinion, drawn partly from lectures delivered by me at the United Service Institution previous to the report of your gun trials.

“In transcribing these remarks, I have little hope of being able to change the opinions of those who are wedded to other principles; but, as the law of action and reaction seems to me to be misunderstood, or rather misapplied, by many with respect to fire-arms, I trust to be able to induce the unbiassed to re-examine the subject, and judge for themselves. I trust also to be able to show that my opinion is not at all inconsistent with your idea of a model gun (*Field*, April 17)—namely, that ‘it is one with which the *greatest execution* can be done upon the object shot at, without such a severe recoil as to make its use disagreeable to the sportsman.’

“‘Gunpowder, when ignited,’ says a high authority, ‘expands with equal forces in every direction, and, consequently, it acts equally on the bottom of the bore and upon the ball during the passage of the latter along the cylinder, supposing it to fit tightly. Hence, neglecting the allowance which should be made for the frictions of the ball and the gun-carriage, the velocity of the recoil will be to that of the shot inversely as the weight of the gun to that of the shot. Thus, supposing the initial velocity of a 24lb. shot to be 1600 feet per second, and the weight of the gun with its carriage to be 57·7 cwt., or 6462lbs., we shall have 5·9 feet per second for the velocity of the recoil.’ ‘The proportion,’ says another military writer, ‘which the velocity of the recoil bears to that of the ball is inversely as their weights, due allowance being made for friction.’

“Such is the formula which is employed for computing, from the recoil, the velocity of the shot at the instant of its leaving the gun. This theory has been a recognised doctrine for more than a century. It is now spoken of as an

ascertained fact, and has, consequently, been laid aside as that which need never again be questioned. It has become so intimately associated with the science of gunnery, that the attempt to substitute another theory, to assign another law of force, may be deemed by many the wandering of an erratic mind, or the presumption of an ignorant man. But the general acceptance of a theory is no proof that it is the most true and most perfect that will ever be presented; nor is it any evidence of a want of reverence for such men as Robins and Hutton, that we believe and assert that no individual is without error or has attained the whole truth; that no authority, however great, should determine and settle every principle in philosophy.

“The theory of recoil, as at present established, has, no doubt, formed the groundwork for the belief of many who, unfortunately, in making their calculations, make no allowance whatever for the friction alluded to in the formula, nor for other causes of retardation. Military experiments, which were carried on in the United States on a large scale, have proved, that ‘by increasing the charge of powder beyond one-third of the weight of the shot, the recoil is increased in a much higher ratio than the initial velocity of the shot.’ The results of experiments with the gun-pendulum have also been found to be frequently at variance with those obtained from the ballistic pendulum; and these variations I have found increased more and more as the distance was increased from the gun. Indeed, the great difficulty of hitting the ballistic pendulum fairly in the centre at long ranges has rendered that mode of carrying on experiments next to impossible. There are, however, other methods of conducting experiments, by which, with collateral evidence, great additional light may be thrown on the subject in question.

“The cause of all motion is the presence of force in the moving body. The degree of the effect is in proportion to the cause; in other words, add to, or take from, the force in action upon given matter, and the quantity of motion is changed proportionally. A certain quantity of gunpowder contains a certain amount of force; the question then is, how can we employ that force so as to obtain the greatest beneficial result from it? The explosion or force of gunpowder

is *repulsion* among the atoms when assuming the form of air. The force of repulsion does not operate by a single impulse, but through a repetition of impulses, or a continued action, of which the effect is accumulated in the inertia of matter ; thus, *all great velocities are the terminations of an accelerated motion*. As in every case of repulsion, two objects at least must be concerned, there can be no motion or *action* without a concomitant or opposite motion or *reaction* ; it is therefore clear that the one must be *repelled* just as much as the other, although with a difference of velocity proportioned to the difference of size. The extraordinary action of gunpowder on the shot, the barrel, and the fore part of the stock, although appearing so sudden, is not an instantaneous but a gradual and therefore accelerating action ; so is the recoil or reaction of the back part of the gun. The action or movement of the charge commences comparatively slowly at first, so does the reaction or recoil. The action of the charge and gradual increase of the gas, *all along the barrel*, is the *cause* ; the action of recoil is the *effect*. The cause begins with the first movement of charge, and ends with the charge leaving the barrel. The retardation of the shot in passing up the barrel and the acceleration of the recoil take place within so short a time that it is not apparent to our senses, and, therefore, to some may appear momentary ; but the mind perceives the nature of the phenomenon as distinctly as if a large ball were rolled against the end of a long steel spring, and thrown back again from it.

“ For the same reason that all great velocities require continued action or repeated impulse to produce them, so do they also to destroy them—the inertia of motion and of rest being exactly equal. The perfection of machinery depends much on diminishing among the moving parts the *resistance* which arises from friction. The explosion of gunpowder being a repulsion among the atoms when assuming the form of air, its greatest efficacy would be destroyed if the shot were prevented by unnecessary friction from starting gradually on its course with the very slightest force which first affects it. Even such apparent trifles as certain unguents increase, and others decrease the *friction of quiescence*—that is, increase or diminish the force requisite to produce the

first movement. At this instant the action of the powder is comparatively slight, so is the reaction by friction, &c., and so is also the force of the recoil ; for the action of the charge in passing through the last three quarters of the barrel—overcoming friction and other causes of retardation—is the great cause of the recoil which is felt, unless, indeed, the charge is improperly jammed down when loading. This may be proved by cutting off three-fourths of the barrel and firing the same quantity of powder and shot from a recoil-rest. It would then be seen that it is not the original repulsion which caused the motion that man uses as his servant, but the momentum *gradually accumulated* by such free and unopposed repulsion, and the progressive, though rapid, ignition of all the particles of the powder.

“ Of friction there are two kinds. The first is denominated *sliding*, and the second *rolling* friction. They are governed by the same laws, though the former is much greater in amount than the latter, under given circumstances. A round ball fired from a smooth bore will leave the muzzle with *greater* velocity than an elongated bullet fired from a rifle—the calibre of both and the charge of powder being the same—but the recoil of the smooth-bore gun will be *less* than that of the rifle, simply because a very small proportion of the surface of the round ball, which has a rolling motion, can ever come in contact at the same time with the sides of the barrel. There is, therefore, less friction, and, consequently, less retardation to the accumulating speed of the round ball before it reaches the muzzle : still action and reaction will be equal, as the *extra* force which the bullet carries with it, *after* leaving the muzzle, is just so much force deducted or taken from the friction and recoil—the first being the *cause* of the *greater effect* in the second. This is easily proved by firing both bullets through a revolving meter from a recoil-rest. It may be added, however, that, if both bullets were fired at the same instant, at the same elevation, the elongated bullet would soon overtake the round one and pass it, as the latter, being lighter, would sooner be retarded by the friction and resistance of the external air. This may also be easily proved by noting the degrees of elevation necessary to make both bullets range the same distance.

“ If a similar round ball were cast into smaller shot, say thirty-two to the ounce, it would be found, by the revolving meter and recoil-rest, that the initial velocity of these would be less than the single ball, and the recoil considerably greater. The explanation is this : in consequence of there being a number of small shot instead of a single large one, they would lie, when loaded, in a cylindrical position, each shot of the outer circle touching the sides of the barrel ; so that in the aggregate they would occasion greater friction, and, consequently, greater retardation to their own progress in passing up the barrel—action and reaction would, however, still be equal.

“ In like manner an equal weight of No. 1, or eighty pellets to the ounce, will leave the muzzle with a greater velocity and less recoil than No. 6, or two hundred and seventy pellets to the ounce ; the smaller shot approaching nearer (and the more so as it is smaller) to the solid form of an elongated cylindrical bullet ; in fact, an elongated bullet is but a more considerable number of particles or atoms of lead lying close together, and, if of a cylindrical form, causing greater friction on the sides of the barrel.

“ This closeness of the pellets and their tendency to cause more or less friction in passing up the barrel may be seen at a glance, by those who are acquainted with the nature of friction, on pouring an ounce and a half or two ounces of each sort of shot into a glass tube the size of a gun barrel—the one sort to be poured on the top of the other, with a wadding between each two. A careful examination of such a collection should teach the sportsman, that the smaller the shot the less in weight he should use, if he wishes to insure a high velocity. By reducing the quantity he would also reduce the recoil.

“ Any addition to the usual quantity of shot will cause a greater amount of friction in its passage, just the same as adding to the length of the cylindrical portion of a rifle bullet. Thick tight wadding also retards, and adds to the friction of the charge. When the barrel becomes foul the friction is also increased. Cartridges, which might easily be made on an improved plan, cause more friction than loose shot ; and cartridges with bone dust still more, though, in consequence

of the shot being longer kept together in a mass, the shot ranges farther. In fact, anything that increases the friction increases also the recoil, and lessens the initial velocity of the shot. The very reprehensible method of freeing or relieving the bore—that is, making it somewhat wider towards the breech—creates also a greater amount of friction, by retarding the passage of the shot. This plan was much patronized at one time by the Americans, but it has lately, and very properly, been exploded by the United States Government as unscientific, and *worse* than useless. It would be difficult, however, to convince some people that it is so: for many have an idea that an advantage is gained by retarding the shot until the gases evolved by the ignited powder have time to act; but, as these gases are rapidly though progressively evolved, any resistance must operate injuriously, as the velocity of the shot cannot possibly increase after it has left the muzzle. Moreover, if a cartridge be used, it must sit too easy in a freed bore, allowing a portion of the gases to escape past it, and mix with the already condensing air in front of the charge in the barrel, causing greater recoil and retardation to the shot. If loaded with loose shot it must cause greater friction, as the mass of shot must be contracted and lengthened before it can leave the muzzle, greater recoil and diminished velocity being the result. A barrel so relieved may shoot with more velocity than one which is *supposed* to be a perfect cylinder; but a careful examination of both, with all their accessories, will show that such relief *alone* is not the true cause of the superiority.

“In firing with some barrels and certain charges it often happens that a portion of the powder employed is driven out in an unconsumed state; it may therefore appear feasible that by retaining the shot a sufficient length of time this portion may be brought to bear upon it; but the cause of the powder not being wholly consumed must be attributed to the practice of ramming down the charge too tightly, or charging with more powder than the length and calibre of the barrel will beneficially burn, and not to the shot passing out *too* freely. The object of granulating or corning powder is to enable the flame to play freely amongst the mass. The charge, therefore, should never be tightly rammed down, or

this great improvement in the manufacture of gunpowder will either be partially or wholly nullified. In arranging the proper quantity of powder and size of grain for a charge the fact should not be overlooked, that though there may appear to be no powder thrown out unburnt, yet, as the charge is ignited gradually, and the combustion is quick or slow according to the size of the grains, a considerable portion is often burnt outside the barrel without falling; the immense velocity of the flame enveloping the unburnt grains, and setting fire to them even after they have left the muzzle of the piece. Any extra amount of powder, therefore, that may thus be used will add to the force of the recoil, but not to the velocity of the shot, as it adds to the dead weight which the inflamed portion of the powder has to lift.

“As a further practical illustration that great recoil is no test of great velocity, let any man take a three-grooved rifle, having the lands as broad or broader than the grooves, and test its initial velocity and recoil, as before, with a nicely fitting bullet and a proper charge of powder. Let him then place the rifle in the hands of a careful rifle-maker, to have a circular shallow groove run up on each land, exactly parallel to the others. Let him then test the rifle again, and he will find that the velocity of the bullet is now greater and the recoil less, and the rifle, consequently, considerably improved. The intelligent marksman or gun-maker will at once perceive that the result is simply owing to there being less friction; for be it remembered that in the *act* of expanding, the bullet is also in the act of moving forward, and until it is fully expanded, into the grooves, the pressure and retarding friction is caused by the *lands* alone, and which, being so broad, must also, to a certain extent, retard the quick expansion of the lead into the grooves. In fact, a portion of that power which should be beneficially employed in expelling the shot is uselessly expended in overcoming friction, causing at the same time more recoil—action and reaction being still, and always, equal.”

With every word that bears directly on the subject of recoil in this letter I fully agree, though there are some points which may be disputed, as for instance the opinion

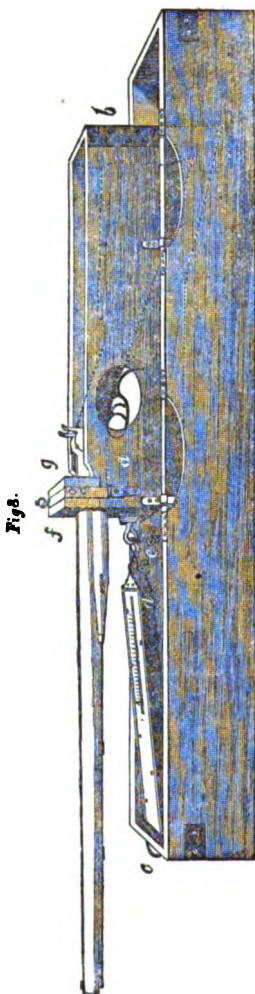

which is expressed adverse to the adoption of relief, a term used by Mr. Boucher for what is commonly called "opening behind." This, however, will be discussed hereafter.

In order to show practically the truth of the opinions held by Mr. Boucher, the results of the gun trial held at Hornsey Wood House on the 4th and 5th of July, 1859, are here appended. It will be necessary to exclude from the list all those guns which were fired with a different charge of powder, and to compare together only those of which all the essential elements were alike. The machine adopted was merely a wooden carriage (Fig. 8 *a b*) containing the gun securely fixed in a horizontal position. This carriage slides backwards and forwards in a frame which is firmly fixed to the ground, and it is attached in front to one of Salter's balances (*c d*), fitted with a slide which registers exactly the extent to which the index is drawn out by the recoil of the gun. The carriage is carefully padded with Indian rubber to prevent injury to the stock or barrels, which latter are secured by the block (*f g*). At the trial, the carriage was made to run on wheels, but it is better to construct it as here represented, running freely on metal slides. A thumbscrew (*e*) in front presses the carriage back till it draws out the index to 10lbs., that being at least the pressure with which the gun is

brought against the shoulder, and many people using as much force as would amount to 25 or 30lbs.

By examining the whole table given elsewhere, it will be seen that the average recoil of the guns of a 12 and 13-bore was $66\frac{1}{2}$ lbs., and of 14, 15, and 16-bore $64\frac{1}{2}$ lbs., the highest recoil in Class 1 being 76lb., and the lowest 59lb. In Class 2 the highest was also 76lb., and the lowest 44lb. These results are of great interest, and establish the fact which I have always contended for, that the recoil is not in exact proportion to the shooting force of each gun; for, taking the gun which heads the first class, the two barrels penetrated through 28 and 33 sheets respectively at 40 yards, yet the recoil was less than that of the next, by Mr. Prince, which pierced 28 and 22 sheets, and still less than the third in that class, which penetrated 25 and 28. The same holds good throughout the series, and I think it may be alleged that, granting the truth of the test, the proportion of recoil to shooting power varies considerably, and that the greatest kicker is not necessarily the strongest shooting gun. Another interesting point established by the trial is, that the Joe Manton gun sent by Colonel White is by no means remarkable for its amount of recoil, the average of its two barrels being 31lb. under that of the average of all the guns tested in its class; and, lastly, the breech-loaders are shown to be quite equal in recoil to the average of the muzzle-loaders.

Thus, in the first class, the three guns standing highest on the list, and showing nearly as great a power of penetration as any, have respectively three, two, and one degrees below the average of recoil, and exactly in an inverse ratio to their performances.

The want of relation between penetration and recoil is still more remarkable in the second class, in which Mr. O. Smith's gun showed a penetration of 38 and 22, with the two barrels, and a recoil 8 degrees below the average; while one of Mr. Reilly's guns, with a slight diminution of penetration, was thirteen over the average in recoil, and this is still more remarkable with the other two guns. I believe, therefore, it may be asserted, that within certain limits it is possible to obtain an increase of penetration without an increase of recoil.

Description of gun.	Bore.	Length of barrel.	Weight of gun.	Charge of powder.	Charge of shot.	No. of sheets pierced.	No. of shots through 20 sheets.	Total on face of target.	Total through target.	Gross total.	Recoil of each barrel in pounds.	Variation from average recoil for 2 barrels.	Total hits.
FIRST CLASS.													
Mr. Pape's muzzle-loader	12	30	6 11	2½	1½	28 33	5 2	399	68	467	68-63	3 under	470
Mr. Prince's muzzle-loader	12	30	7 6	2½	1½	28 22	1 2	363	53	416	66-65	2 under	418
Mr. Pape's muzzle-loader	12	20½	6 8	2½	1½	25 28	1 1	331	55	386	68-64	1 under	387
Averages of the whole class	—	—	—	—	—	26 30	1 1½	265	59	344	67-66	—	344
SECOND CLASS.													
Mr. O. Smith's muzzle-loader	15	30	6 14	2½	1½	28 22	3 5	925	63	393	63-58	8 under	401
Mr. Reilly's muzzle-loader	14	29	6 4	2½	1½	32 27	0 8	274	67	341	68-74	13 over	328
Mr. P. Haast's muzzle-loader	15	30½	6 8	2½	1½	28 29	5 0	206	62	269	68-67	6 over	263
Mr. Reilly's breech-loader (Lefauchaux)	15	28	6 4	2½	1½	18 28	0 0	225	46	271	68-72	11 over	260
Averages of the whole class	—	—	—	—	—	26 27	2 1½	277	56	334	66-64	—	334

The amount of recoil which can be pleasantly borne by the shoulder, will vary somewhat with the weight of the gun. Thus, a light one of 6lbs. will show perhaps a recoil, according to the machine, of only 65lbs., yet it will be more unpleasant to shoot than another weighing 8lbs., which recoils 70lbs. according to the same test. According to my experiments, I believe that with guns of the usual weight and bore, that is, from 7lbs. to $7\frac{1}{2}$ lbs. for 12-bore, and a quarter of a pound less for each diminution of size, the recoil, in order to be pleasantly borne, should not on any account exceed 70lbs. Those who are particular in this matter will prefer to have one showing 10lbs. or even 15lbs. less, but to get the highest degree of penetration, the amount of recoil above fixed must be incurred.

The chief causes of undue recoil, are the disproportion of the projectile to the powder, the excessive quantity of the latter, inordinate opening of the barrel, roughness of the metal, or fouling of the barrel, and lastly, a want of sufficient weight of the whole gun to give *vis inertiae* to resist the force of the explosion. Some of these vary with the state of cleanness in which the gun is, and with the charge with which it is loaded, but the others continue the same under all circumstances.

COMPOSITION OF GUNPOWDER, GUNCOTTON, AND OTHER EXPLOSIVE MIXTURES USED WITH THE GUN.

In order to force the projectile to its proper destination, two explosive substances only have as yet been usefully applied—namely, gunpowder and guncotton; but there are others which are used merely to procure ignition by percussion in some shape or other, being introduced into small metal capsules denominated percussion caps, or into some similar convenient vehicle such as Lancaster's copper disk.

Gunpowder is composed, in all cases, of three substances—nitre, sulphur, and charcoal—but the proportions adopted by different makers vary to some extent. In a work of this nature, intended for the sportsman only, it is scarcely necessary to enter upon the new chemical combinations which follow the explosion of this potent agent, but it may be men-

tioned that in theory every particle of the original substances of which it is composed should be converted into gas, leaving no residuum to foul the barrel. In practice this is never the case, for though a powder may be made so correctly as to burn away almost entirely on a piece of white paper, yet in a tube it will always leave a stain over and above the sulphuret of potassium, which is a necessary product, and this increases if not wiped away with each succeeding discharge. The reason of this is, that there is no air admitted to supply extra oxygen for the sulphur to combine with, and this material, therefore, robs the nitre of a small portion of that element which is wanted to effect a perfect union with the carbon in order to form the carbonic oxide and acid which result. Gunpowder may be made entirely of nitre and charcoal, and for large charges it answers perfectly well, but for sporting purposes the addition of sulphur has many advantages, preserving the other two materials from the effects of damp, and also maintaining the granulation which is so important in effecting perfect combustion. In this country the proportions which are thought to answer best in practice are—

Nitre	77½ lbs.
Charcoal	16 „
Sulphur	10½ „
	—
	104 „

This will make 104lbs. of powder, leaving the 4lbs. for loss by waste in the various operations of mixing, pressing, granulating, &c. These three substances must first be ground into a very fine powder, and mixed together most intimately, so that the atoms are mechanically prepared for instantaneous combination as soon as they are heated to the temperature which admits of it. But if left in this state of fine powder, though the combination is very rapid in the parts first heated, yet the flame cannot permeate the mass, and it burns imperfectly *as a whole*. To avoid this difficulty the powder is first wetted, then pressed and dried, and afterwards made up into grains of various sizes and shapes, according to the use for which it is designed. This

is called granulating; and powder is sold of several degrees of coarseness, commencing with No. 1, which is the finest in use, and increasing in the size of the grain up to No. 5. After the granulation is effected the grains are generally more or less glazed by friction, in barrels which are made to revolve rapidly; and, finally, the resulting dust being sifted out, the powder is packed.

As fine-grained powder explodes more rapidly than coarse when not crushed, or in large quantities, it follows that it is more suited for short barrels and small charges, such as, for instance, in pistols or carbines. The aim, in all cases, should be to use powder in such quantity and quality that the whole of it is burnt just as the projectile leaves the muzzle of the gun; for if it is all converted into gas before that period of time, the projectile has to overcome the friction of the sides of the tube without any increasing force as it goes on, and consequently loses some of its propellant power. If, on the other hand, all the powder is not burnt before the projectile escapes, there is a waste of powder, and this is the most frequent and the least injurious result. On firing a full charge over the snow, a few grains of powder entire may almost always be picked up beneath the line of flight of the charge. Those, therefore, who are careful in such matters, will adopt the necessary precaution to ensure the proper charge of the right kind of powder for the particular gun they are using.

The desiderata in gunpowder will therefore vary considerably according to the charge, to the length of barrel, and to the mode of firing it. In every case, however, it should be *clean*, that is to say, it should leave no perceptible residuum on firing it loosely on a piece of white paper. The first test to apply is the following, which also shows that the powder is dry and easily exploded:—Take five or six drachms of powder and divide it into two heaps, placed on a piece of white paper; then fire one of them with a red-hot wire, and if the two explosions do not sound as one, the powder is bad or damp; while if any steam is left, or the paper is burnt in holes, there is an imperfection somewhere. The smoke, also, should be of a whitish grey. In relation to the charge, the powder should be coarser according to the

amount which is used, but for sporting purposes, other than for punt guns, either No. 2 or No. 3 is always selected. The choice between these will depend upon the mode of firing it, for if the ordinary nipple and percussion cap are used, the combustion of No. 2 is not too rapid, and it will answer the best; besides which, the size of its grain allows it to pass up the nipple, which No. 3 will not do. Where the firing is more central, as in the various breech-loading cartridges of Lefauchaux, Lancaster and Needham, the coarser grain of No. 3 should be selected, as it is found to burn entirely before it leaves the muzzle in the ordinary charge of $2\frac{1}{4}$ to 3 drachms; and so also, in the case of rifles, where there is more resistance to be overcome and more time occupied in doing it, the coarser powder is to be preferred. It is usual to judge of powder by its appearance when rubbed in the hand, and it is considered that when rubbed on a moderately dry palm it should leave the faintest possible stain of lead colour only. If it blackens the skin it is to be rejected, as such powder is found to foul the barrel in a similar manner.

There is very little difference in the quality of the powder made by the various eminent firms who now divide the trade between them. They are Messrs. Curtis and Harvey, Pigou and Wilks, Lawrence and Son, Hall and Son, in England; and in Scotland, the Kames Company, who have offices in Glasgow, Liverpool, and London.

Captain Brown, of Rumsey, has lately made a most important discovery which completely upsets all the previously received theories of the action of gunpowder. By slightly moistening powder with a thin solution of gum, and at once pressing it in a mould, he is able to consolidate it so as to bear any ordinary usage, each charge being picked up with the finger and thumb and inserted in the gun. What seems most extraordinary is, that these consolidated charges may be exposed to the air without deterioration, and I have myself fired them without any apparent loss of power or quickness of ignition after lying about exposed for three months in a room without a fire. As far as I have tried the plan it promises many advantages, but my experiments have been not sufficiently extensive to enable me to offer any decided opinion about it. It has, I believe, been tried by the Government officials, and reported on extremely favourably.

Gunpowder is sold in paper at 2s. 3d. per lb., and in canister at 2s. 6d. If large quantities are taken a reduction is made in the price; but it must be remembered that fire insurances are rendered invalid by keeping a stock of this dangerous substance on the premises.

When gunpowder has become damp it is readily and safely dried by placing the canister or flask in a jug of boiling water with the mouth open, and occasionally taking it out and shaking its contents. This is much safer than the ordinary plan of drying it before the fire, and with a little care answers equally well.

Guncotton consists of finely carded cotton wool which has been submitted to the following process:—Nitric acid of specific gravity 1.5 is mixed with concentrated sulphuric acid, and in this mixture the cotton is steeped for a few minutes; it is then taken out and squeezed, after which it is carefully washed in pure water and dried by a very gentle heat, when it will have increased in weight seventy per cent., but in appearance it is unchanged. It explodes at a much lower temperature than gunpowder, that is, at a little above 300° Fahr., so that it requires much greater care to avoid accidents, and on that account alone is objectionable as a substitute for it. It burns without smoke or residue, but the explosion is so rapid that the projectile power of this substance is not so great as that of gunpowder, while, at the same time, the recoil caused by it is increased. It has also the disadvantage attending on it that the charges must be weighed, as they cannot be measured by bulk as is the case with the powder in common use. It is not, therefore, surprising that, in spite of its greater cleanliness, it has not come into general use, being much more dangerous with less power of projection, more recoil, and the above-mentioned difficulty as to the calculation of the charge.

In spite of these objections, however, guncotton has been recommended by Captain Norton to be used, in particular where it is desired to have a cartridge without the necessity of biting it, as is now done in the army and navy. By enveloping the cotton in a fine net, which is tied to the base of the bullet, and may also be rendered explosive in the same way as the cotton. the flame of the cap readily fires it,

and the whole is blown away. This trifling advantage is, however, entirely done away with by adopting explosive paper for making up the powder into cartridges, as is practised by Mr. Prince with his breech-loader. But even this is now rendered unnecessary if the caps made of black antimony are used, which readily pierce paper of any thickness that can be required for the purpose.

An explosive cartridge paper may be made by preparing it in the same way as described for guncotton. The paper should be porous; and ordinary blotting paper answers very well if made sufficiently stout. But this paper, like guncotton, explodes at a temperature very little higher than 300° Fahr., and it is therefore dangerous to keep together any number of cartridges enveloped in it. The plan is exceedingly ingenious in theory, and for sporting purposes it is practically well adapted, as it is easy to avoid the above heat in this country, but for military cartridges the danger of spontaneous combustion is too great when large masses of all sorts of substances are brought together in the hold of a ship; and even the magazine may possibly have its temperature raised to that degree.

The various detonating powders used in the manufacture of caps, disks, or tubes for firing the gunpowder of the charges in our fowling-pieces and rifles are so rapid in their combustion as to be useless as a substitute for the two materials which have been already described. Their explosive force is so enormous and sudden that they will burst the barrel, however strong, instead of moving the projectile in front of them, if employed in sufficient quantity to propel it as far as gunpowder will do. So rapid is the combustion of fulminating mercury, that if a train of gunpowder is crossed by a train of it, and the latter is fired in the usual way, with a poker or wire, the mercury, in its explosion, being more rapid than that of the gunpowder, cuts off the connexion between the two portions of the train, and the second half is not fired at all.

Fulminate of silver, which is even more rapid in its explosion, is prepared by dissolving 40 or 50 grains of silver (a sixpence will be the most convenient) in $\frac{3}{4}$ oz. by measure of nitric acid of specific gravity 1.37 or thereabouts, with the

aid of a gentle heat. To the solution, while still hot, add 2 ounces by measure of alcohol, continuing the heat till reaction commences, when the nitric acid oxidises part of the alcohol to aldehyde and oxalic acid, becoming itself reduced to nitrous acid. The last-named acid in its turn acts upon the alcohol, the result being the production of nitrous ether, fulminic acid, and water. From the hot liquid the fulminate of silver is slowly deposited in the form of small, white, brilliant crystalline plates, which should be washed with a little cold water, and spread upon separate pieces of filter-paper, *in portions not more than a grain or two each*, after which they are left to dry in a warm place. When dry the papers are gently folded up and preserved separately in a box or bottle, this being the only safe mode of keeping the salt. It is one of the most dangerous of all chemical substances to handle, and explodes when heated, or when rubbed or struck with a hard body, or when brought in contact with concentrated sulphuric acid, with an enormous force, owing to the sudden disengagement of a large volume of gaseous matter, leaving the metal reduced.

When fulminate of silver is digested with caustic potass, one half of the oxide is precipitated, and a compound is produced which resembles the neutral salt of silver, and detonates with a blow. This is sometimes used for the manufacture of anticorrosive percussion caps, but it has very little advantage over the—

Fulminate of mercury, which is prepared by a process very similar to that described for fulminate of silver. One part of mercury is dissolved in twelve parts of nitric acid, specific gravity 1.37, the solution being mixed with an equal quantity of alcohol; gentle heat is then applied, and if the reaction becomes very violent, it may be kept down by the addition of more spirit as required. A large volume of carbonic acid, nitrogen, nitrous and aldehyde, and red vapour is disengaged, and the hot liquid deposits the fulminate of mercury, which may be purified by solution in boiling water and re-crystallization. It explodes either by friction or percussion, and when fired burns with a sudden and almost noiseless flash if kindled in the open air.

To form the mixture which is used in the ordinary caps,

sulphur and chlorate of potass (or more frequently nitrate of potass) are mixed with the fulminate of mercury, and the powder being pressed gently into the cap, is secured there by a drop of varnish.

Chlorate of potass and sulphur are sometimes used without fulminate of mercury, or silver. Equal parts of these two substances are carefully prepared, and mixed together without any friction between hard substances, which would cause an explosion. The mixture is then pressed into the caps and secured as before described. Caps so prepared are, however, very uncertain in their explosion, and they are also highly corrosive in the action of their residuum on iron. *The Government caps* are filled with a composition consisting of chlorate of potass, 6 parts; fulminate of mercury, 4 parts; and powdered glass, 2 parts.

Whatever substance is employed it should be protected externally by a copper cap or disk, and it should also be covered with a layer of some varnish, which will defend it from the effects of the atmospheric air.

Messrs. Eley and Joyce are the two chief makers of caps in England, independently of the Government, and it would be hard to say which is entitled to the pre-eminence, for the productions of either may be taken as approaching so nearly to perfection as to leave little to be asked for. At present they each make two kinds—one small, and adapted to ordinary guns, and the other larger and stronger, as ordered by the Government, and suited for rifles, especially when a cartridge paper has to be pierced. Eley's caps are coated with a metallic foil, which is intended to prevent decomposition by contact with air or moisture, while those made by Joyce are covered with "a highly waterproof substance, burning with the same facility as the powder itself, and in no degree detracting from that certainty and sharpness of fire, as well as anti-corrosive property, so necessary for the convenience and comfort of those who use them." These words are from Mr. Joyce's circular, but I can speak to their correctness from experience. The price of the sporting caps by either of these makers is 1s. 6d. per box, containing 250, or 5s. 6d. per 1000. In all cases the caps ought to fit the nipples with which they are used, and in ordering a lot

the nipple should be sent to the gunmaker. The Birmingham and London sizes do not correspond, the following being the relative sizes of Mr. Eley's with the Birmingham scale:—

Eley's . .	5	6	7	8	9	24	10	11	18	12	13	14
Birmingham	48	44	46	48	49	50	51 & 52	53 & 54	55 & 56	57	58	

Caps made of black antimony, and specially adapted from their strength for piercing the paper of cartridges suited to breech-loading rifles, are sold by Mr. Westley Richards, of Birmingham, or by his London Agent, Mr. Bishop, of Bond-street.

CHAPTER III.

ON THE VARIETIES OF PROJECTILES AND THE SUBSTANCES USED IN AID OF THEM.

ALL SPORTING PROJECTILES MADE OF LEAD—EITHER CAST OR PRESSED AS IN BALLS, OR DROPPED FROM A HEIGHT AS IN SHOT—SHAPES OF BALLS—SIZES OF SHOT—WADDING AND PATCHES—CARTRIDGES.

ALL SPORTING PROJECTILES MADE OF LEAD.

Lead is the substance of which all sporting projectiles are made, whether they are used in the size of a four-ounce ball or in that of dust shot. There is some difference in the quality of this metal, which is often alloyed with zinc, when its specific gravity is greatly reduced, though it is somewhat harder than the pure metal. The latter should, however, be preferred, as weight will have more effect than hardness in producing penetration. The price of lead is about 3*d.* to 3½*d.* per lb.

Balls are cast of various shapes and sizes in moulds which are generally made to open like a pair of pincers. In order to avoid the slight variations which are found to exist in all cast bullets, Mr. Greenfield has invented a simple machine, by which each cylindro conical ball is driven through a gange by means of a punch. It is a very useful contrivance for muzzle-loading rifles, in which an exact fit is required. These forms of bullets vary almost indefinitely, every cal-

ceivable shape having been tried; but this will be better considered in connexion with the rifle itself. A spherical ball used with a smooth bore is now seldom adopted for any kind of shooting, as its flight beyond one hundred yards is so uncertain that no reliance can be placed upon it.

Shot are small globular pieces of lead, of various sizes from rather less than a quarter of an ounce each to such a small diameter as to take nearly two thousand to make up that weight. Messrs. Parker and Co., of London, are the chief makers in the south, and they have the following sizes, which are each said by Col. Hawker to contain the annexed number of pellets in the ounce:—

MOULD SHOT.

L.G. contains in the oz. . . .	5½ pellets.
M.G. " . . .	8½ "
S.G. " . . .	11 "
S.S.G. " . . .	15 "
S.S.S.G. " . . .	17 "

PATENT DROP SHOT:

A.A. contains in the oz. . . .	40 pellets.
A " . . .	50 "
B.B. " . . .	58 "
B " . . .	75 "
1 " . . .	82 "
2 " . . .	112 "
3 " . . .	135 "
4 " . . .	177 "
5 " . . .	218 "
6 " . . .	280 "
7 " . . .	341 "
8 " . . .	600 "
9 " . . .	984 "
10 " . . .	1726 "

Dust shot variable.

These numbers will, however, be found to vary considerably from those of which an ounce of the shot as now

sold is composed, depending a good deal on the quality of the lead used, the specific gravity of which is scarcely ever the same. I have counted the pellets in an ounce of shot used at the recent gun trial, and find them to be 290. The makes of other firms are also differently sized, as will appear from the experiments of a writer in the *Field*, under the signature "G.," who says:—

"Most people suppose that an ounce of No. 6 shot is the same all over the world, and so did I until I had the curiosity to compare the contents of several bags of shot and cartridges by different makers. The following is the result:—

NUMBER OF SHOT CONTAINED IN ONE OUNCE.

	No. 5.	No. 6.	No. 7.	No. 8.
From Messrs. Parker and Co., London	326	537
Messrs. Cox and Co., Derby	230	...	335	...
Messrs. George and Co., Bristol	219	...	298	421
Eley's "Universal" Cartridge	180
Joyce's "Universal" Cartridge	220	326
Eley's Patent Muzzle-loading Cartridge	249
Hall's Patent Cartridge	270

"The shot was very carefully weighed in a fine pair of scales and counted, and in most instances an average of three ounces taken. I have no doubt that my friends, the gunmakers in London, make their trials with Parker's shot; while I, living in the West of England, made mine with the shot manufactured at Bristol."

There is evidently some mistake in some of these numbers, as there is no make of No. 6 which will contain 326 pellets in the ounce. Cartridge-makers all use the full size of shot, because their object is to increase the distance at which they can kill, and not so much to improve the pattern. I have counted as few as 260 pellets in Eley's, and 270 in Joyce's No. 6. I have also often found mistakes in the numbers—thus, cartridges marked No. 5, have contained No. 4 or No. 6; and in this way it is easy to see that the error has arisen in the instances where "G." has found 326 pellets in an ounce of No. 6, which really was No. 7, though probably marked No. 6.

The best size for general use, and that almost universally

adopted in the early part of the season, is No. 6; but let it always be remembered that, *cæteris paribus*, small bores take smaller shot than larger ones. Later in the season, No. 5 may be introduced into use. Some shoot with No. 4, and others, again, consider No. 7 or 8 not too small; but every sportsman has his own fancy, and much depends upon the distance at which he generally shoots. Some men prefer dropping their game as soon as they are on the wing, and for them a scattering gun and small shot will answer the purpose better than a close-shooting gun with larger shot. Others, on the contrary, wait to cock their guns in the most deliberate way, and always allow their birds to get forty yards off before they fire; by these a larger shot must be used, or their game would almost always escape. Many men use mixed shot; but I believe this plan is essentially bad, producing an irregularity in the delivery which constantly leads to disappointment. Sometimes, also, it is oiled, but this also appears to be perfectly useless—though it is most probably harmless, unless the oil is very sticky, when it causes the shot to ball. Small shot, from causing greater friction, requires more powder than large, and therefore, if the usual charge with No. 6 occasion as much recoil as can be borne, the weight of any smaller shot used must be reduced.

In ramming down shot care should be taken not to crush it out of its spherical shape, which is easily done if too much force is used, either in loading at the muzzle or in filling cartridges.

Wadding and patches are mechanical means of retaining the powder and shot or ball in their places. They vary according to the kind of gun or rifle used, and each, therefore, will be better described in their respective places.

Cartridges are cases of paper or pasteboard, and are of two kinds, one intended to be driven out of the barrel with the shot, which it keeps together for some distance, the other being employed to assist the loading, and being generally retained behind. These, also, will be described with the guns for which they are intended.

Powder flasks and *shot pouches* are of service for any kind of shot-gun, and they always form a part of the accessories

included in the gun case. In the annexed engravings the usual form of them is given (see fig. 9 *a*), which represents the best kind of powder flask covered with leather, and (*b*) the most convenient form of shot pouch. The old shot belt is now seldom used, and if carried over the shoulder it has no advantage over the pouch; but for real hard work, as in wild pheasant or cock-shooting, a belt buckled loosely round the waist, just above the hips, is far the most convenient form. Fig. 9 (*c*) shows the best form of *cap holder*, which may be suspended from a button-hole, and is then always ready for use.

Fig. 9.

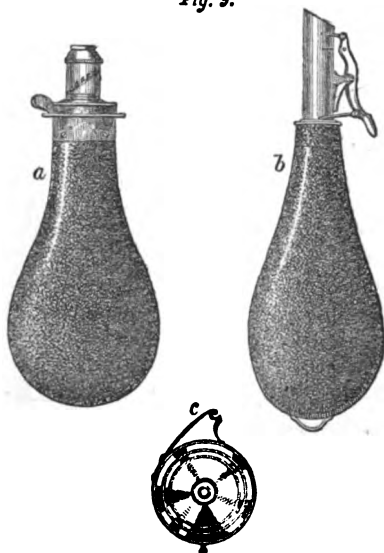

POWDER FLASK, SHOT POUCH, AND CAP HOLDER.

BOOK IV.

THE VARIETIES OF SHOT-GUNS AND THE ACCESSORIES USED WITH THEM.

CHAPTER I.

THE PARTS COMMON TO ALL SHOT-GUNS.

GENERAL REMARKS—THE BARREL—THE BREECH—PROVING—THE LOCK—
THE STOCK—THE TRIGGER AND GUARD—PERCUSSIONING—CASE-
HARDENING—BROWNING—THE CLEANING-ROD AND RAMROD.

It has already been mentioned that all shot-guns consist of a barrel or barrels, in the form of a cylindrical tube more or less converted into a cone at one or both ends, one of which is closed with a breech. In addition to this there is a lock for firing the charge; a stock for holding it conveniently to take aim, and a trigger for discharging the lock. These parts are put together and finished by special workmen, and the barrels are generally "browned" to prevent the action of damp upon the polished metal, and also to show the kind of iron of which the barrels are made.

THE CLEANING-ROD AND RAMROD.

For muzzle-loading guns a ramrod is almost always appended, though sometimes where, as in covert shooting, a second gun is carried, the person in charge also has a loading rod, and then the guns are made without the usual appendage. Breech-loaders, of course, do not require it, but for them also a cleaning-rod is required, which has adapted to it proper heads for fixing tow to wipe out the barrels, or for removing lead by means of a scratch brush. The ramrod will be described with the ordinary percussion gun.

THE BARREL.

The Barrels of all shot-guns are made of iron, either in its most malleable form, or in the shape of steel, or of a mixture of the two. For a long time the iron obtained from old horse-shoe nails was considered the best for the purpose, but as a great proportion of these are now produced of very inferior iron, they are not so much to be relied on as formerly. Germany, Russia, and Sweden still make their nails of the best iron, and if they can be obtained with certainty, there is nothing better. Mr. Adams, of Wednesbury, now produces a quality of iron which has almost entirely superseded the use of "stub" nail-iron, and in the trade it is that known as "Wednesbury stub-iron." He also manufactures two kinds of steel known as "silver steel" and "common twist steel," which are employed either alone or mixed with stub-iron. These two kinds differ in the mode of their manufacture, the former being twisted and the latter rolled, but both being made from the clippings of steel springs, saws, &c. Mr. Greener is celebrated for his laminated steel, which he makes as follows:—"I generally have the metal required cut into short pieces of six inches long. A certain number are bundled together and welded, and then drawn down again in the rolling mill. This can be repeated any number of times, elongating the fibres and multiplying their number to an indefinite extent, as may be required."—*Gunnery in 1858*, p. 154.

This quality of metal no doubt produces excellent barrels; but, as Mr. Greener remarks, it requires great care in the working. "Damascus iron" and "wire twist" are both made from a number of alternate bars of iron and steel forged together into one rod—which, for Damascus, is exactly three-eighths of an inch square. This is then twisted while at a high temperature, and shortened thereby one-half. The next process is to weld three of them together, in such a way that the twist of the middle one shall run the reverse way to those on the outside, thus: which gives an exact idea of a pickled piece of Damascus iron in the rough. The common twist is not so much twisted as the Damascus; and, according to the high authority of Mr. Greener, is therefore

stronger than it; but this opinion is in opposition to the general verdict of those who have used the two kinds, and which is

Fig 10.

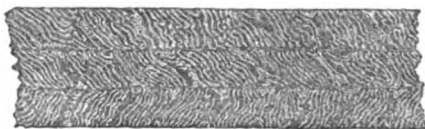

BAR OF DAMASCUS IRON. (FULL SIZE.)

certainly in favour of Damascus iron. All figured barrels are produced on this principle, modified according to the kind of pattern required; but there are some made by unprincipled persons, which on the surface present it, without extending any deeper, and being therefore in no wise more safe in consequence. This is effected by plating or veneering on a thin layer of this twisted iron, the substance of the barrel being of a very inferior quality. This fraud it is almost impossible for the amateur to discover, and he is therefore entirely in the hands of his gunmaker, unless he is able to brown a small portion of the interior at the muzzle, when the nature of the two kinds is at once visible.

The proportion of steel which is adopted in the making of gun barrels varies greatly among the different makers, some going so far as to use three-fourths of steel to one of iron, while others reject the steel altogether. But the old-fashioned soft barrels are now seldom used, and the great majority are made with from one-third to one-half of steel in them. When the soft iron in this is condensed by cold hammering, the result is a material which, while it is sufficiently tough to resist the force of the explosion, is also elastic enough to react upon the charge, and drive it out with all the force which can be desired.

The following are the CHIEF VARIETIES of iron which are used in this country for first-class guns—namely, 1st, "Damascus Iron;" 2nd, "Wire Twist," or "Stub Twist;" 3rd, "Laminated Steel;" 4th, "Stub Damascus." Inferior guns are manufactured of, 1st, "Charcoal Iron;" 2nd, "Threepenny Skelp;" 3rd, "Twopenny" or "Wednesbury

Skelp;" and 4th, "Sham damn Skelp." The method of making Damascus iron I have already alluded to, and have also given an engraving of the appearance which it presents in the bar. The following is an accurate representation of a portion of a pair of barrels made of this iron—being those which performed the best in the second class at the gun trial of 1859.

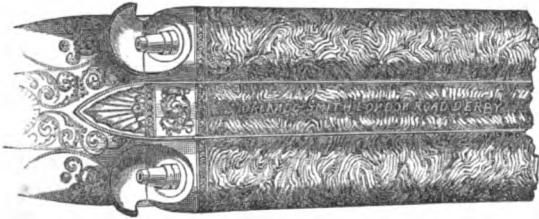
Fig. 11a

DAMASCUS BARRELS. (HALF SIZE.)

A *much finer twist* is sometimes made, especially in Belgium; but there is no advantage obtained, and it is generally supposed to weaken the iron. This very fine kind of Damascus is shown below, having been carefully copied from a pair of barrels of English manufacture, sent by Mr. Hast, of Colchester, to be shot in the trial of 1859.

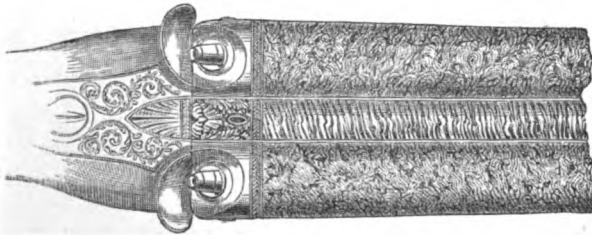
Fig. 11b

FINE-GRAINED DAMASCUS. (HALF SIZE.)

An imitation of these twists, as practised by the Belgians, is well represented in the annexed engraving, which shows

Fig. 11o

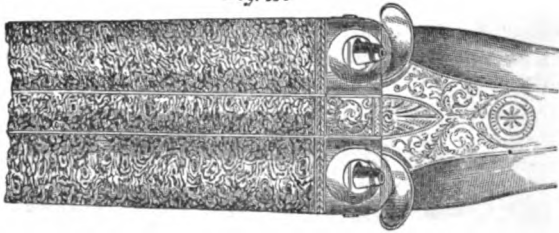

IMITATION DAMASCUS. (HALF SIZE.)

the extent to which this fraud is carried. But by comparing the factitious surface with the real, it will be seen that there is an important point in which the former fails, consisting in the broken line which so constantly occurs in it; while in the real article the fibre, though equally tortuous, is almost always continuous. Sometimes, however, the deception is so clever that it requires great skill to discover it, and even in the gun from which the above illustration was taken, a common observer might readily pass it as perfectly genuine.

Wire Twist, or *Stub Twist*, is made nearly in the same way as Damascus, but is less twisted, and displays the following appearance when browned:

Fig. 12

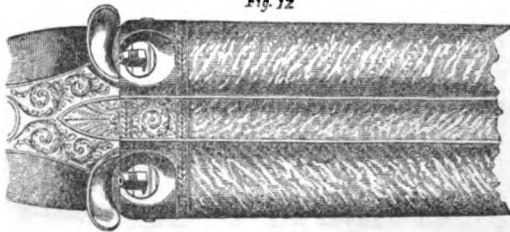

STUB TWIST. (HALF SIZE.)

The manufacture of laminated steel has also been alluded to at page 213, where an extract from Mr. Greener's treatise

will be found. Its surface, when browned, is as shown below, having been copied from one of Mr. Pape's guns, which was shot in the trial of 1859.

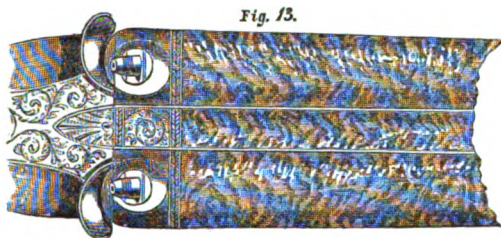

LAMINATED IRON. (HALF SIZE.)

This kind of iron is also used in a slightly different form, known as "angularly laminated," but there is so little to distinguish the one from the other in any respect, that I need scarcely enlarge upon it. What is called "fancy steel" is also a sub-variety of laminated steel, and should not be considered a distinct kind.

Stub Damascus is often called "steel," but it is really a mixture of the two kinds, and is the weakest of the four included in this division. It is made from old files reduced to a coarse powder, and then fused together with a larger proportion of stub-iron, after which it is rolled into rods, and twisted in the same way as the Damascus. Its appearance when made up is given in the annexed engraving, which is

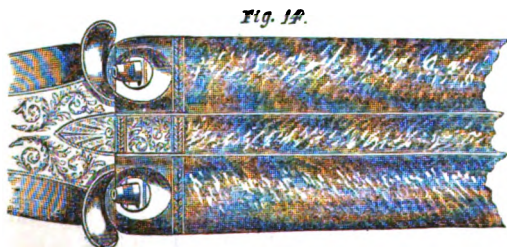

STUB DAMASCUS. (HALF SIZE.)

taken from a gun sent to the trial of 1859, by Mr. Egan, of Bradford.

Charcoal iron is the best quality used for inferior guns; it is made from the clippings of sheet-iron, melted in a charcoal furnace, and re-cast, then forged into a bar and rolled into rods in imitation of stub-twist. The iron, when in contact with the charcoal, absorbs a certain amount of carbon, and becomes hardened, but as the metal from which it is made is originally of a weak description, it still remains of very inferior quality. Its cost is very low, being about 4*d.* per lb., and as it may be made to look well by a peculiar method of browning, it is much employed by inferior makers, the saving on a pair of barrels in material alone being tenpence to a shilling, as compared with stub twist, besides the reduced cost of forging, which adds two more shillings to the saving effected; and this proportion is kept up throughout the subsequent processes. The appearance of charcoal iron when browned is represented in the annexed cut of a pair of barrels.

Fig. 15

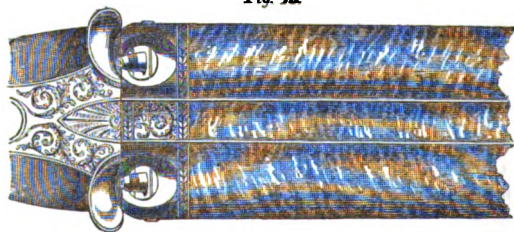

CHARCOAL IRON. (HALF SIZE.)

Threepenny, but more commonly *twopenny skelp*, is used for very inferior guns in this country—such as are sold by ironmongers and general dealers at very low prices: namely, 3*l.* and 4*l.* for a double gun. As, however, my readers are, I hope, not likely to trust their lives to such articles, I shall only give the annexed engraving, showing the appearance of twopenny iron when browned and made to look as pretty as possible to the eye.

Fig. 16.

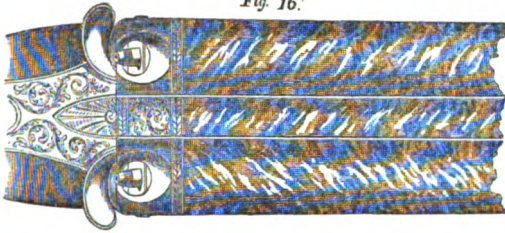

TWO PENNY IRON. (HALF SIZE.)

By comparing this with threepenny skelp, it will be seen that there is no great difference between them; but the figure is bolder in the twopenny iron, and not nearly so variegated in its twist. In quality there is no great superiority in the one over the other, but of the two, the higher priced iron is to be preferred.

Sham damn is too bad even for our general dealers, and it is solely used for the guns made for exportation. As a matter of curiosity, however, I append a sketch of the aspects which it bears after being made up artificially to please the eye.

Fig 17.

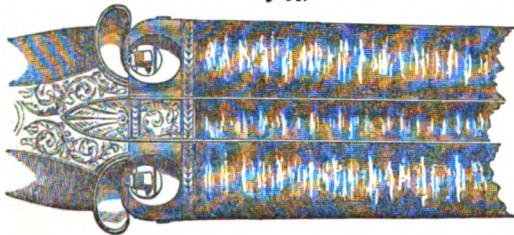

SHAM DAMN. (HALF SIZE.)

All of these three last kinds of iron are made from scrap iron of qualities varying in proportion, the scrap used for *sham damn* being of the worst possible kind. The process

of manufacture is nearly similar to that alluded to under Charcoal-iron.

In forging the iron into barrels the same principle is not adopted in all cases, some being twisted, while others of the commonest kind are joined longitudinally into a tube. Both these processes are now carried on only at Birmingham, London at present not containing a single forge for the purpose. The process of forging twisted barrels is as follows:—The rod after being heated is twisted into a spiral form by means of two iron bars, one fixed and the other loose. In the latter, which is turned by a winch-handle, there is a notch which receives the rod, and this being prevented from turning round with it by means of the fixed bar, is compelled to assume a spiral form. According to the breadth of the rod will be the quickness of the spiral, which varies from that shown in the accompanying sketch, to the

Fig. 18.



BREADTH OF ROD IN BEST GUNS. (HALF SIZE.)

form given in the lowest quality of sham damn, or two-penny skelp, which are forged in bands of the following width, but which nevertheless are not bettered by this

Fig. 19.

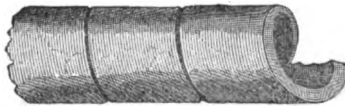

BREADTH OF ROD IN COMMON GUNS. (HALF SIZE.)

twisting. When the rod is completely converted into this spiral form, it is removed and suffered to cool, while others are being bent the same way; and the next process is for the welders to join several of these together, and at the same

time weld the edges of the bent rods by the blow of the forge hammer at a white heat. The welder commences with a stout spiral of sufficient thickness for the breech ends, heats it to his mind, and then, removing it from the fire, gives the end a smart blow against the anvil, known by the technical term "jumping." This is repeated till the welding is complete, when a second portion is put into the fire, and the two ends being brought into contact so as to fit, which requires considerable practice, a "jump" on the anvil welds them together. By repeating this operation again and again the proper length for the barrel is obtained, and then the tube is made as perfect as possible at this stage by hammering it at a proper heat on a mandril, the external surface being made circular by placing it in a groove corresponding to its intended form. After this hammer-hardening by means of light hammers is adopted for the purpose of consolidating the texture of the iron, and then the twisted barrel is completely forged. For forging the plain barrel the smith takes two bars of iron, bends each of them over a mandril into rather more than a half circle; then heating them to a welding heat, he places both upon the mandril with their edges overlapping, and welds them together by repeated blows of his hammer.

The *boring* and *grinding* are effected by the person who is called the "barrel-maker," though certainly the smith might more properly be entitled to that appellation. Of these barrel-makers London contains several, and indeed every gunmaker would probably assert that he employs a workman of this class, though in many cases the same man works for several masters. It must be remembered that when forged the barrel is only a rough tube, the internal bore being smaller than it is intended to be when finished, and allowing of the removal of a considerable quantity of metal. The first thing to be done is to convert the interior into the nearest possible approximation to the form which it is intended to maintain permanently, and this is done by boring it with a machine called a "bit." This instrument may either be used by the hand, when it is fixed in a stock and made to turn in the interior of the barrel, or it is placed in the spindle or "chuck" of a frame, which has also a

carriage for the barrel to travel in, and is exactly similar in principle to a turner's lathe. The boring bit, being selected of a proper size, is placed in the centre of the spindle, ready to revolve as soon as the latter is set in motion; the barrel is then fixed in its carriage, so that it may gradually be pushed on upon the bit as the latter clears its way, and then the spindle is made to revolve by attaching its driving-wheel to the motive force, whether hand or steam. The bit is square for about twelve or fourteen inches, with four angles, two of which are ground sharp, while the other two in the finishing operation are kept from the interior of the barrel by a slip of wood, which diminishes the friction considerably. Water is constantly poured upon the barrel as the work goes on to keep it cool, and when the bit has cleared its way through, another, slightly larger in size, is introduced, till the barrel is of a proper bore. When the interior is finished it bears a fine polish, but it is a mere cylinder, and will still require some slight modification to make it shoot correctly; but this is generally done by a hand bit. Next comes the grinding of the exterior, which is either done by means of large stones made to revolve with great velocity, and against which the workman holds the barrel, allowing it at the same time to turn round comparatively slowly in the hand; or a self-acting lathe is made to take the part of man and stone, and any number of barrels are then turned out exactly similar to each other in every respect but in the metal itself, which of course may and will vary slightly. The method by turning is the more true, but if care is not taken to keep the machinery in perfect order the tool is apt to tear up the surface and overheat the metal, which can be more completely avoided by the grindstone.

When the barrels are thus bored and ground, they have still to be put together if for a double-barrelled gun, and in any case to be breeched, cut to a proper length, and finally bored for shooting. In the first of these operations, considerable nicety is required in order to direct both barrels at the same object. It must be remembered that the breech-end is much thicker than the muzzle, and consequently in placing together two barrels as they come from the stone or lathe, if the two external surfaces touch at both ends, the

internal ones are not parallel. If, therefore, they were soldered together in this form, and shot from a fixed rest, the line of fire of the two would cross at a few yards from the muzzle, varying in distance according to the thickness of the breech. To avoid this objection, the iron of the opposite sides of each barrel is cut away until they approximate sufficiently, for an exact parallelism is to be avoided, because in shooting from the shoulder, the weight of the other barrel causes in each case a slight inclination in the opposite direction from the true axis. A rib of iron is introduced between and above the two barrels, and this is slightly elevated, to allow for the tendency to fall which shot has even at forty yards' distance. Mr. Greener is of opinion that this dropping of the shot is about twelve inches in forty yards, but it varies considerably in different guns, and according to the charge. This may, however, be taken as an approximation to the truth, but for all practical purposes any very exact calculation is useless, inasmuch as the shooting of guns will in great measure depend upon the proportion of powder to shot, and also in no slight degree upon the way in which they are "stocked." Mr. Prince has proposed a plan for elevating one barrel slightly more than the other before brazing them together, so that one shall hit the mark exactly at 40 yards, and the other at 60. This seems likely to be of service for double guns, the objection that one barrel would be thereby more frequently used than the other, being met by the explanation that towards the end of the season long shots are the rule, and 40 yards the exception, and that "right and left" being then unusual, the more elevated barrel may be used for single shots. For pigeon-guns it is particularly applicable, and I think also for general shooting. When the two barrels and the rib are accurately fitted, they are soldered permanently together. The usual practice is to braze four or five inches with hard solder, but Mr. Greener shows the impropriety of this plan, inasmuch as it requires a white heat for its performance, which expands the iron again to the state in which it was prior to the cold-hammering. He asserts, and I believe with perfect truth, that soft-soldering, if properly done, is quite strong enough, and he declares that he never uses any other method, which, as his guns are well

known to be as strong as any others, is a sufficient guarantee of its efficiency.

THE BREECH.

The barrel or barrels having been brought to the condition of tubes open at each end, in order to complete them, it becomes necessary to close one of these by some means, which may be either a plug screwed in permanently, as in the percussion gun, or temporarily, as in the needle-gun and some other breech-loaders, or by some mechanical means keeping a block of iron in close apposition with the end of the barrels. These various methods must be described more minutely under the respective guns to which they belong.

PROVING.

All shot-guns must now be proved twice before they can be sold, according to an Act passed in the year 1855. The first is called a "provisional proof," and is carried out when the barrel is in the rough, but the second requires that it or they shall be pretty nearly finished—that is to say, if a double gun, both barrels shall be soldered together, the breeches adapted, and the nipples screwed in. By this change in the method of proving, the trial is really a sufficient one, and I believe we shall hear of fewer guns bursting every year, as the old ones proved under the former régime become displaced from general use. Revolving arms are only proved once—that is, after they are made up, for as the barrel is not intended to contain the charge, it is not complete without the addition of the chamber. Breech-loading guns, not being revolvers, are tried provisionally as well as after they are completed. The penalties for forging proof-marks and for selling guns without them, are so heavy, that the offence, I believe, is rarely committed. According to Schedule B. of the "Gun-barrel Proof Act" of 1855, small arms are divided into five classes, as follows:—

1st. Single barrelled military arms of smooth bore.

2nd. Double barrelled military arms of smooth bore, and all rifled arms whether double or single barrelled, not being revolvers or breech loaders.

3rd. Single barrelled shot guns.

4th. Double barrelled shot guns.

5th. Revolving and breech-loading small arms of every description.

The powder used is of government strength, and the balls are all spherical and of lead. Barrels for the second and fourth class, and for breech loading arms of the fifth class shall be proved both provisionally and definitively; all other arms shall only be proved definitively.

Barrels for arms of the third class shall not be proved until they are in a fit and proper state for setting up with the permanent breeches in; and all barrels "lumped" for percussioning shall be proved by means of the nipple hole.

In proving the second and fourth classes:—

(a) *Provisionally.* If of plain metal they shall be bored and ground, having plugs attached, with touch-holes drilled in the plugs of a diameter not exceeding $\frac{1}{16}$ th of an inch. If any touch-hole shall be enlarged from any cause whatever to a dimension exceeding in diameter $\frac{1}{16}$ th of an inch, the barrel shall be disqualified for proof. Notches in the plugs instead of drilled touch-holes shall disqualify for proof. If of twisted metal they shall be fine-bored, and struck up with proving plugs attached, and touch-holes drilled as in the case of plain metal barrels.

(b) *Definitively.* The barrels, whether of plain or twisted metal, shall be in the finished state, ready for setting up, with the breeches in the percussion state, breaks-off fitted, and locks jointed; the top and bottom ribs shall be rough struck up, pipes, loops, and stoppers on, the proper breeches in, and the thread of the screws shall be sufficiently sound and full for proof.

Barrels for revolving arms of the fifth class shall have the cylinders with the revolving action attached and complete.

Barrels for breech loading arms of the fifth class shall be subject to *provisional* proof according to the class to which they belong, and to *definitive* proof when the breech loading action is attached and complete.

The proof marks differ according as they are made at London or Birmingham.

The London mark of provisional proof consists of the letters (G P) in a cypher, over which is a lion rampant. For the Birmingham provisional proof the mark is a cypher (B P) beneath a crown. See the annexed figure, giving an enlarged view:—

LONDON.



BIRMINGHAM.



FIG. 20. PROVISIONAL PROOF MARKS.

The definitive marks remain as before, as shown in the following engraving, about twice the actual size:—

LONDON.



BIRMINGHAM.



FIG. 21. DEFINITIVE PROOF MARKS.

The proof marks are impressed on the following parts of the various classes:—

On the *first* and *third* class the definitive proof mark is impressed at the breech end of the barrel; and if with a patent breech, on that also.

On the *second*, *fourth*, and *fifth* classes the provisional mark is impressed at the breech end of the barrel, the definitive mark upon the barrel above the provisional; and if

there is a patent breech, or revolving cylinder or chamber, the former mark is also to be impressed on that.

On all barrels the gauge size shall be struck both at the provisional and definitive proofs.

The provisional proof charge for a No. 12 double barrel shot gun is 350 grains of lead, and $12\frac{3}{4}$ drs. of powder; and for the definitive proof, 219 grains of lead and 8 drs. of powder, the charge of each being increased or diminished in proportion to the gauge. Now, the above weight of powder being nearly three times the usual charge, it may be considered that if a gun, when finished, passes this severe ordeal, it is scarcely likely that it will burst with ordinary care when employed for sporting purposes. The proof charges are now the same in London and Birmingham.

THE LOCK.

The Locks of guns vary a good deal, but the principle in all cases now is to cause ignition by a blow on some detonating substance. This is effected by a spring, which is compressed and held back by some means, and when let go by the pressure of the trigger it drives the striker on to the detonating powder. The various plans adopted will be alluded to under the respective guns; but it may be mentioned that the form of the mainspring is the chief part in which they differ. In the ordinary lock the spring consists of a plate of steel bent to a very acute angle, one arm being fixed to the lock plate, while the other is moveable, and at its free end acts upon the striker. The second form consists of a spiral spring which, when compressed and let loose, drives a striker, having a needle attached, straight forward to the detonating powder.

THE STOCK, INCLUDING THE FALSE BREECH.

The object of the stock being to enable the shooter to adapt the gun to his eye, and having little or nothing to do with the mechanism or performance of the piece, it is of importance that he should be exactly suited in the former respect. If a gun stock is not of proper length, and bent to fit the

arm of the person for whom it is intended, it is in vain to expect that he will be able to shoot well with it. The

Fig 22.

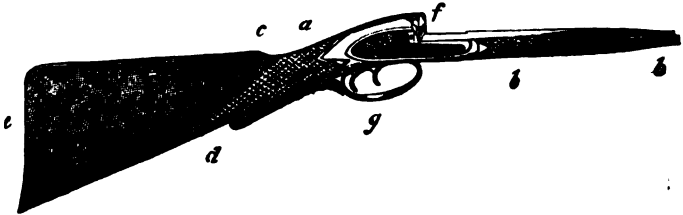

STOCK WITH SAFETY GUARD.

gunmaker, therefore, must either know the length of arm and neck from measurement or his own inspection, or he must give his customer a variety to select from, and then stock his gun to the exact pattern of the one which pleases him. The wood of which gun stocks are made is almost always walnut, that being found to keep its shape the best, and also having toughness sufficient, combined with good grain and colour. In selecting it, the direction of the grain at the "handle" (*a*) is to be examined, for if here it is across, it will be likely to give way on any slight blow. The fitting of the barrels and locks into it must be very exact, or dirt and damp soon get in and decay the wood. Around the handle it is crossed, or "chequered," to give a firm grasp; and good workmen pride themselves upon doing this very regularly. It requires much practice, being done by hand; and, therefore, as the Birmingham gunmakers have the best chance in this respect, they ought, as they do, to excel all others in it. The usual length is from fourteen to fifteen inches from the fore-trigger to the heel; but the amount of bending cannot be so easily calculated. In front the stock passes forwards beneath the barrels (the "foreend," *b b*), and here it is generally hollowed out to receive the ramrod; and, in the percussion gun it is traversed by one or two slides, to connect it with the barrel. Behind the handle is the "comb" (*c*), a thin projection, which increases the surface applied to the cheek. Here is sometimes a raised smooth

block, called a "cheek-piece." All that part behind the handle is called the "butt" (*d*), and the lower or back end of this is the "heel" (*e*), in which is generally let an iron-plate—the "heel-plate." The form of this is somewhat familiar, being intended to adapt it to the muscles of the shoulder, for which purpose it is nicely hollowed out in its long diameter, and slightly rounded in the opposite direction.

In addition to the adaptation in length and bend of the stock, it is also "cast off"—that is to say, it is bent sideways; and it is especially here that good stocks differ from bad ones. If the barrels are heavy forwards, the stock must be loaded at the heel, to make the gun balance; but in the present day this is seldom needed. At the front of the handle the break-off (*f*) is fixed above, and the trigger and guard (*g*) below, both of which will presently be described. The break-off is merely a piece of iron, which is securely let in and screwed there, so as to give a firm point of resistance for the true breech, which recoils against it. Many stocks are highly varnished; but as they are liable to scratch, and sometimes, when in the sun, the varnish flashes in a way to alarm the game, it is a better practice to have them only oiled.

THE TRIGGER AND GUARD.

The trigger is simply a lever, intended to raise the sear out of the bent or notch in the tumbler, when the gun is at full cock; and also to lift it out while the striker is being lowered from full cock to half cock. There is little difference in its construction among the various guns, even the needle-guns having one nearly similar to that of the old flint and the modern percussion. Where great delicacy is required, a piece of mechanism called a "hair-trigger" is added. It consists of a separate trigger usually fixed behind the ordinary one, and so arranged that when it is drawn back or "set" the reverse way, it gives a blow to the sear on the trigger being very lightly touched, and thus discharges the piece. When well made the touch of a bristle is sufficient, and hence its name. In order to guard against the trigger being touched in the handling of the

gun, a guard is attached to the stock, being made longer for double-barrelled guns, in order to allow of the two triggers.

A *variety of safety guards* have been invented, to prevent the trigger from discharging the gun, except at the exact moment of being wanted—that is, when applied to the shoulder. One of these acts by pressure on the heel-plate; but as most people load their guns with this part pressing on the foot or ground, it is useless at the exact moment when it is most required. The best I know acts by the pressure of the right hand on the “grip” of the stock, the fingers being sure to lay hold of this part in raising the gun to the shoulder, in doing which a lever is pressed, which liberates the trigger, previously held firmly by it. (See Fig. 23).

Fig 23.

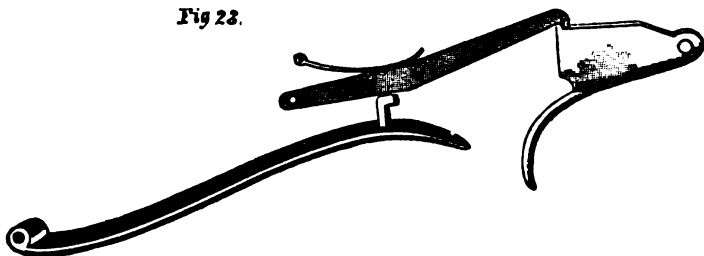

SAFETY GUARD. (HALF SIZE.)

The lower limb of this is shown in fig. 22, beneath the handle; the other parts being let into the stock, and therefore invisible. I am a decided opponent to all complications, and with moderate care and a good lock I believe no gun will explode while being loaded; but certainly I see no objection to this plan on the above score, and for careless shooters it is a most valuable invention. It is generally made in the annexed form, which is a modification of that adopted by Joe Manton; but there is a slight objection to the plan, inasmuch as in passing through a hedge a twig may easily get under the part intended for the hand, and it then becomes impossible to discharge the gun. To remedy this inconvenience it is

only necessary to make the part which appears outside the stock of solid metal, and let it into a socket cut in the wood.

PERCUSSIONING AND SETTING UP.

The drilling and tapping of the hole for the nipple, and the formation of the cross-hole which communicates with the powder is called "percussioning," and is of great importance to the quick and certain explosion of the charge. The adaptation of the hammer and its mainspring to the nipple, as well as the whole arrangement of the several parts of the gun is denominated "setting up," and is the duty of the gun-maker himself or his foreman.

BROWNING, CASEHARDENING, ETC.

The barrels are made up and proved, as well as finally bored, before the last finishing-touch is put to them. This consists in imparting to them an artificial oxidization by means of acid, which forms a coat on the surface that resists the oxygen of the air to a greater extent than the bare metal will do, and the plan is therefore generally adopted, though some sportsmen prefer the plain metal. If the latter case, it must be rubbed occasionally to keep it bright, and in course of time the thickness will be reduced, though, with moderate care, this ought not to be appreciable during the time in which the internal surface will continue good. The following is the usual recipe for staining twisted barrels:—

Take of—Tincture of sesquichloride of iron, $\frac{1}{2}$ oz.
Corrosive sublimate, 1 dr.
Sulphate of copper, $\frac{1}{2}$ dr.
Nitric acid, 1 dr. to $1\frac{1}{2}$ dr.
Spirit of wine, 6 dra.
Water, 8 oz.

Dissolve the corrosive sublimate in the spirit of wine, then add the solution to the other ingredients, and let the whole stand for a month or six weeks, when it will be fit for use. The barrels are first cleaned carefully with lime, and this being removed, the browning mixture is laid on with a sponge

five or six times a day, till the colour is dark enough for the fancy. Once or twice a day a scratch-brush is used to remove the rough oxide and allow the acid to get a deeper bite. When it is considered that enough has been done, boiling water is poured over the barrels for several minutes, and while hot, they are rubbed with flannels and finished with a leather and a little beeswax and turpentine. A brighter red colour is produced by the following mixture:—

Take of—Tincture of sesquichloride of iron, 1 oz.
 Spirit of wine, 1 oz.
 Corrosive sublimate, $\frac{1}{4}$ oz.
 Nitric acid, $\frac{1}{4}$ oz.
 Blue vitriol, $\frac{1}{4}$ oz.
 Water, 2 pints.

Mix as above, and apply with a piece of flannel twice a day; scratch it (with a proper scratch brush) clean each time; when dark enough, scratch as clean as possible, and pour boiling water over it. Polish with a fine linen cloth, and, if requisite, a touch of beeswax and turpentine. Inferior barrels are made to look well to the eye by several tricky methods, chiefly practised at Birmingham, in this country, and at Liege, abroad. Of these the most simple is the use of corrosive sublimate and spirit of wine, which will soon bring out a strong colour if applied in rapidly succeeding layers upon barrels previously prepared with varnish cut away in a pattern, as has been already described at page 216. The smoke stain is the most permanent, but it requires the best metal and a good deal of practice to bring it well out. It is effected by passing the barrels through the flame of a forge at a time when it is of a clear white, without smoke, until the whole is covered with soot; then remove them to a cool and damp cellar for one or two days, by the end of which time they will have become rusty. Treat them with the scratch-brush as before described, and renew the operation with the flame till the colour is thought to be good. Finish with hot water, as before described.

Case-hardening is the process adopted for making the parts of the lock, breech, &c., as hard as possible. It is produced

by covering them with animal charcoal, in a box which is then exposed to a certain heat, and after a time, the object is effected; but this requires practical skill, and no description without it will suffice.

CHAPTER II.

THE MUZZLE-LOADING PERCUSSION GUN.

THE BARREL—VARIOUS KINDS OF BREECH—THE LOCK—THE STOCK—RAMROD—OR LOADING-ROD—THE ENTIRE PERCUSSION GUN AND ITS PERFORMANCES—LOADING AND CARTRIDGES—CLEANING—THE GUN-CASE AND ITS CONTENTS—PRICE OF GUNS.

THE BARREL.

The barrels of the ordinary percussion-cap gun loading at the muzzle are made, as described in the last book, of any of the materials and in either of the modes therein mentioned. As received from the barrel-forgers, they consist of a mere cylinder, which receives provisional proof in that form, and has afterwards to be breeched, stocked, percussioned, proved, and regulated.

BREECHING.

The breech formerly was a mere solid plug screwed into the end of the barrel, which was tapped to receive it; and the touch-hole was drilled so close to its internal end as to cut a shallow groove in it. The invention of the patent breech has however quite superseded this clumsy form, which is now never adopted, except for the purposes of provisional proof. For all percussion cap guns the barrel is now tapped for about half an inch, and into this female screw a piece of iron is adapted, with a shoulder bringing up the external part to a level with the outer surface of the barrel. Within this breech, partly opposite the screw, and partly within the shoulder, a cavity is hollowed out, in which the powder is to lie; and this chamber is variously formed,

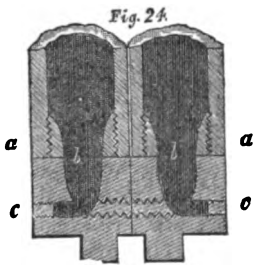

MODERN BREECH. (HALF SIZE.)

according to the fancy of the maker. The following is the most desirable form to be adopted, in which *a a* represent the ends of the barrels; *b b*, the chambers in the breeches; and *c c*, a plug, which fills the outer part of a hole bored across, so as to reach the bottom of the chamber, closing the inner end. This is called the "cross-hole," and is for the purpose of allowing the end of the nipple tube to explode the powder in the chamber without weakening the breech, which it must do if it is directed straight down upon it, as is sometimes done, and as will presently be described. There is a great difference of opinion as to the form which is most advantageous; and as it is not yet settled whether the ignition should be quick or slow, it can scarcely occasion surprise that such should exist. If the ignition is too rapid, there is no doubt that the powder is not all exploded; while if it is too slow, the rapidity of shooting which is necessary for hitting a moving object is not attained. Hence there is doubtless a happy medium to be aimed at, but what that is seems to be at present unknown. As far as my experience goes, I am quite contented with the simple cone terminating in a cup, which is the form represented above. The breech of Joe Manton's choice, who has so long been celebrated for his guns, is a shallow cup ending in a cylinder, which is very little larger than the cross-hole. (See Fig. 25.) In Wil-

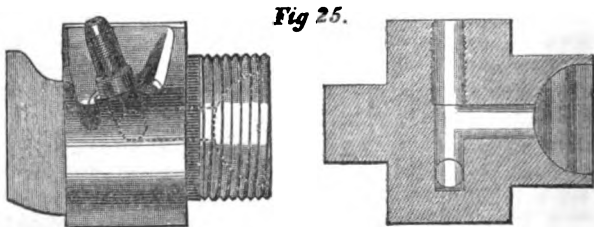

JOE MANTON'S BREECH. (FULL SIZE.)

kinson's, on the other hand, there is an oval chamber, one end connected with the nipple, and the other being contracted so as to retard the ignition.

Great stress is laid upon the form of the breech by all the advocates of the muzzle-loader; and they assert that if the powder is burnt in a chamber of the same size and form as the barrel itself, with a mere closure at right angles, the effect is greatly deteriorated. I have tried the experiment myself, firing the same barrel with different breeches, but I confess I have not been able to obtain any very reliable conclusions. As far as my experience goes, the barrel is all in all; and so long as the breech is sound, and the ignition perfect, it matters comparatively little what shape the chamber may bear. It is very commonly supposed that the recoil is materially increased when the powder is fired anywhere but at its posterior part; but this is now proved to be a myth, and, according to the experiments made by the Board of Ordnance, the recoil is least when the centre of the charge is fired. The Prussian needle-gun, also, in which the ignition is in front, is remarkable for the absence of recoil; so that, I think it may fairly be assumed that the point of ignition has no reference to recoil. There is also another point which requires consideration—namely, whether it is desirable to allow of a vent for the explosive gases at the end of the cross-hole? The proposed object is to lessen recoil, and until very recently most of the better classes of guns were made with a "vent hole," lined with platina to prevent corrosion; but the plan is now almost entirely abandoned, being found to be quite inoperative. The grains of the powder enter the fine hole, and fill it up even prior to the first discharge; but subsequently it is quite closed by the residuum left after the explosion.

THE NIPPLE.

In the ordinary percussion gun, which is that now being described, the powder in the chamber is ignited by exploding a cap upon a nipple, whose canal communicates with the cross-hole of the breech, or, in some cases, with the chamber itself. The nipple in either case is of a conical form ex-

ternally for about the third of an inch, so as to allow of the copper cap securely clipping it; next to this cone is a shoulder, which is square, or, what is better, a rectangular oblong, so as to admit of the application of a key for its removal. Beyond this, again, it is tapped, and forms a male screw, which is accurately adapted to a female screw cut in the breech. Thus, then, there are two things to be considered in reference to the nipple—1st, its own shape; and 2ndly, the direction in which it is screwed into the breech.

The nipple itself should be of good steel not tempered too highly or it will break. The best kind is bored so as to present two cones, one short and external, and the other longer and internal, the communication between the two being small and lined with platinum to prevent the corrosion, which would otherwise soon fill it up; and then comes the pricker, which removes the rust and enlarges the aperture so much that a great part of the gas escapes through it. Ordinary

Fig. 26.

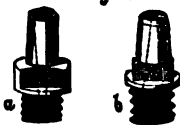

NIPPLES. (FULL SIZE.)

nipples present only one cone, the base of which may be external (fig. 26 *a*), or internal (fig. 26 *b*); the former being greatly to be preferred with good caps, as it allows a full volume of flame to be driven down upon the charge. The platinated nipple is more expensive than the common one, and it is apt to lose the ring of platina, but as long as this adheres it will be serviceable; still for common purposes nothing answers better than the form shown in fig. 26 *a*.

In adapting the nipple to the breech, a hole is sometimes drilled in a slightly oblique direction down upon the end of the chamber. This was first proposed, I believe, by Mr. Greener, as his "centric" method of firing, but as adapted by him it was found to weaken the handle of the stock too much, and he has abandoned its use in consequence. Another maker (Mr. Horton of Whitehaven, late of Birmingham) has re-introduced it as his "eccentric breech," the only difference being that the nipple enters more obliquely and the hammers also fall in a corresponding direction, so that the stock is not weakened to the same extent. But though the latter is improved the breech itself is still weakend at this part, whether

sufficiently so to make it dangerous experience alone can determine. It is certainly an improvement upon Mr. Greener's original plan, and as such is introduced here:—

Fig. 27

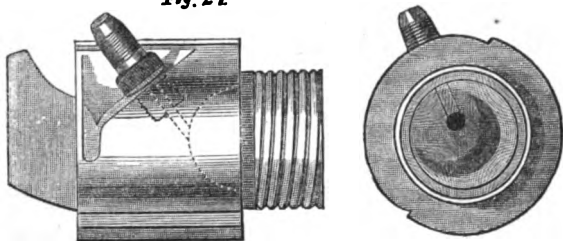

THE GREENER-HORTON BREECH. (FULL SIZE.)

On comparing this with the ordinary breech (fig. 24, p. 234) it will at once be seen that in Horton's plan the nipple is brought nearer to the charge, and may possibly be more liable to be blown out, but with proper care in tapping I have no doubt such an accident would never occur. That the firing is sharper I fully believe from theoretical calculation, but whether in practice the difference would be discovered I do not pretend to say. One advantage is possessed by Horton's breech—viz., that a pin or pricker may be passed straight down into the chamber, and thereby any accumulation may with certainty be disposed of; whereas, in the cross-hole it meets with an angle, and cannot get any further. In the gun-trial of 1858, a gun made on this plan was shot by Mr. Horton and performed well, though from his nervousness the shot from the first barrel almost entirely missed the target.

THE LOCK.

The lock of the percussion gun is a very simple and efficient piece of mechanism, having for its object to explode the cap on the nipple by means of a sharp blow, which must be so arranged as to finish with its greatest amount of strength so as to prevent the hammer from being blown up

Fig 28.

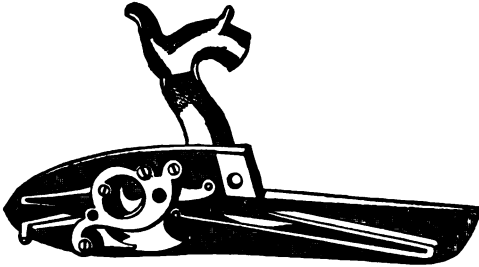

PERCUSSION GUN LOCK. (HALF SIZE.)

again by the force of the explosion. The following are the parts of which this lock is composed, which are the same in number and principle whether it is what is called a "back actioned" lock or not, beginning with

The lock plate and bridle, which when screwed together, form the skeleton (fig. 29)—

Fig 29.

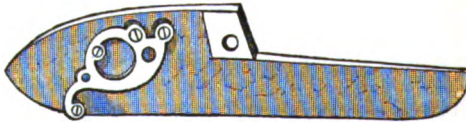

LOCK PLATE AND BRIDLE. (HALF SIZE.)

The cock, or striker (fig. 30 a), which rises and falls outside the plate in unison with the *tumbler* (b), a piece of iron

Fig. 30.



STRIKER. (HALF SIZE.)



TUMBLER. (HALF SIZE.)

of a peculiar shape lying between the plate and the *bridle*, and acted on through the *swivel* (fig. 31, *a*), by means of the *mainspring* (fig. 31, *b c*), which is attached to the plate in its upper half. It will be seen on examination, that by the peculiar form of the tumbler and

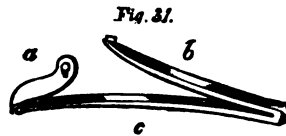

MAINSPRING AND SWIVEL.
(HALF SIZE.)

swivel, the lever upon which the spring acts is longer when the striker is down on the nipple than at full or half-cock, and thus it exerts its greatest force in that position. In the back of the tumbler (*b*) are two notches or "bents," one deeper than the other, which are intended to receive the *scar*. This and its spring (fig. 32) are both attached to the *bridle*, lying between it and the plate, and working upon two screws, which pierce them. The *scar* has a sharp tooth which



drops into the notches of the tumbler one after the other, and is kept there by the spring. When the *scar* is dropped into the half-cock bent, this is so deep that it cannot be depressed out of it by raising the other end by means of the *trigger*, and consequently the gun cannot be fired in that position. But at full cock the notch is much shallower, and a force usually equal to about 3 or 4 lbs. will disengage it when applied to the *trigger*. The *side nail* is the screw which attaches the lock to the stock, through the hole drilled in the plate in front of the cock. This lock may therefore be considered as consisting of four important divisions:—(*a*) the skeleton or plate and *bridle*; (*b*) the cock and tumbler; (*c*) the mainspring and swivel; and (*d*) the *scar* and *scar* spring.

(*a*.) *The shape of the plate* has three chief variations—one the fore-acted bar-plate, being that which is engraved above, and which is now generally used for best guns, the front part being accurately fitted to the barrel. In the old plan there was a thin layer of the stock intervening, which was apt to be splintered; but this is only now used for cheap guns, in which the wood is made to cover bad workmanship. The back-acted lock, as shown in the Lefauchaux gun

(fig. 33), was introduced some years back, in order to keep the works out of the way of the corrosive gases which were formerly generated by the explosion of the cap, but these being now of a much milder character, the advantage of this useful invention is not equal to the disadvantage attending upon the weakening of the stock, which is essential to this form. The plate being let into the grip on both sides, a large portion of the wood is cut away; and this part was found to break on the slightest blow. On the bridge it is scarcely necessary to make any remarks, as there is little or no difference in its shape in any case.

(b.) *The striker* should be of such a shape as to be readily raised and commanded by the thumb whilst the forefinger is acting on the trigger and at half-cock releasing the sear, in order to let it down when desired. The mouth should also be wide enough to permit the cap to fall out readily after its explosion, and it should be so fitted as that its striking face shall fall flat upon the end of the nipple. The metal must be good, or that will give way under the blow.

One of the most important parts of the lock is the tumbler, upon the proper construction of which in great measure depends the smooth action of the mechanism and its safety in use. If it is not of hard metal, and true in all its bearings, it will soon wear, and when new, it will not "speak" as it should do, nor after use will its worn-out notch properly catch the sear. The practised hand and ear readily detect the false ring from the beautiful feel and tone given out by one of Brazier's best locks, but the tyro will be wholly unable to detect any difference, and he must trust to the character of the maker to sell him what will suit his purpose. Much also depends upon the pitch and shape of the sear, and as the one must be accommodated to the other, a good workman will be required to adjust them exactly.

(c.) *The mainspring* should be of excellent temper, and should have a force equal to about ten pounds or a little over, that being the lowest which will ensure the explosion of the cap under all circumstances. It is desirable to avoid unnecessary power in giving the blow, because it is liable to break the nipple or the striker itself. As the spring is most at liberty when the cock is let down, the gun should always be put by in that position.

The addition of the swivel is a great improvement to the lock, for the reason before alluded to, and this part also requires careful workmanship and adjustment.

The sear spring is usually made with a power of about three pounds, that or a little more being the force exerted upon the trigger in ordinary guns. *The importance of giving a proper shape to the sear* and of making it of good metal, cannot be overrated.

There is a great difference in the price of locks, which can be obtained as low as 4*d.* a piece wholesale; but even for very cheap guns intended for the foreign market, 1*s.* 6*d.* to 2*s.* a pair is generally the lowest price. For single guns 1*5s.* is a fair price, and for the best doubles £3 a pair.

THE STOCK.

The stock of this kind of gun does not in any way vary from the model described in the last chapter. It may or may not be fitted with the safety guard there described, and it may have one or two loops by which to connect it with the barrels. Ordinarily one loop is considered sufficient for double guns. Single guns of large bore are sometimes made with two loops, as the fore-end of the stock is made longer in them, to enable the hand to be carried well forward.

THE RAMROD.

This part of the muzzle-loading gun is of some importance, for if it is badly made, it gets out of order or breaks, and renders the gun useless at a moment probably when it is most wanted. The wood should be of a tough kind, and not liable to warp. The head must be large enough to carry the wads down without jamming in the barrel or admitting a shot between. For those who care about dirtying their gloves, this part should be gilt, as it does not then become corroded by the gases resulting from the explosion. Care should be taken that it fits easily in the loops, and that the screw which is capped at the end to enable the wads to be laid hold of and withdrawn is of a proper shape. When the ramrod is not fitted, a loading-rod is required to be carried by an attendant, and it is made somewhat larger and stouter in all its proportions.

THE ENTIRE PERCUSSION GUN.

When the various parts already described are well and carefully made and put together by a first-class workman, the result is a most efficient gun, which will do its work as well as anything yet invented in all respects but two, or perhaps three. These are to be found in the slowness of loading, in the danger attending upon the process, inasmuch as the hand must more or less cover the muzzle, and in the fouling and leading of the barrels, the latter of which defects requires the occasional use of the scratch-brush to remove the coat of lead that not only injures the shooting qualities, but adds greatly to the recoil. With these exceptions, I think it is generally agreed that the percussion gun is faultless, and it remains to be seen whether they can be got rid of without interfering with the good qualities which are by general consent attributed to it.

As the percussion gun is allowed to be equal, if not superior, to any other in shooting qualities, it will be well to consider it as the standard in these respects, and then to compare others with it. I have already said, that a fowling-piece should combine in its performances, (a) a good pattern in the target made by it, united with as much strength as possible; (b) a fair weight, so as to avoid tiring the sportsman; and (c) such an absence of recoil as will render its use for hours and days together not unpleasant to the shooter.

(a) A good surface-pattern may be shown upon an iron plate, or any other smooth surface, and upon these a practised eye can also distinguish the amount of strength with which the gun shoots, nearly enough to form a pretty correct opinion. The spreading of each shot upon the plate is the test which is adopted, because the more impetus is given to the shot the more they are flattened against the iron. So also in a door, the wood of which is known, according to the driving power of the gun will be the penetration of the shot; but as doors are constructed of various woods, and as, after some exposure, each of these will become softer on the surface, this test is a very bad one, and is not to be compared with brown paper. When this last material is employed, a single sheet will

suffice for the surface pattern; but for penetration several thicknesses will be required. According to my experience, a good muzzle-loading gun of twelve-bore, with a charge of $2\frac{3}{4}$ drachms of powder and $1\frac{1}{4}$ ounces of shot, No. 6, will distribute *evenly* about 150 to 160 shots on a thirty-inch target at forty yards, and 55 to 65 at sixty yards. The same gun and charge, at forty yards, will drive three or four of its shot through from thirty-five to forty thicknesses of a twelve-inch square of 90 lb. bag cap brown paper, and through from twenty to twenty-five thicknesses of the same at sixty yards. Occasionally a single shot may exceed these amounts, but they may be considered the average of what may be expected from a first-class gun. This, however, will be more clearly seen by a reference to the table of the performances of the guns at the *Field* gun trial in 1859, hereafter given.

(b) The weight of a muzzle-loader is the point which regulates the bore; for if the sportsman requires a light gun he must be contented with a small bore; while, on the contrary, should he be regardless of weight, a No. 12, or even a still larger gauge, would generally be chosen, as being capable of carrying a large charge better than any smaller size. The following may be considered as the lowest safe weights of the several bores likely to be used:

No. 12	$7\frac{1}{4}$ lbs.		No. 15. . . .	$6\frac{3}{4}$ lbs.
No. 13	$7\frac{1}{4}$ lbs.		No. 16. . . .	$6\frac{1}{2}$ lbs.
No. 14. . . .	7 lbs.		No. 18. . . .	$6\frac{1}{4}$ lbs.

(c) The absence of unpleasant recoil with a fair charge of powder and shot depends chiefly upon the boring of the barrel, and to avoid it certain principles are sacrificed, which but for this essential, would be carried out. Thus it will be found that, within certain bounds, the more the shot is confined within the barrel, until the whole of the powder is exploded, the stronger will be the shooting. To effect this, however, in the fullest degree, the recoil will be so great as to forbid its use; and here also there must be a sacrifice of one to the other, just as in the case of weight and calibre. With a well-made gun shooting as described under (a) the recoil is not higher than sixty-five pounds, as tested by the machine

which is described at page 196, and this is about what the average of sportsmen would consider a pleasant-shooting gun.

LOADING.

There are several points to be attended to in loading this kind of gun, if the most is to be made of what can be done. Thus, supposing a good pattern is desired, then the charge of powder must be reduced; while, on the other hand, if hard hitting is the object, the powder is increased in proportion to the shot. Again, if it is desired to make the gun shoot slowly, the powder is to be rammed down into a solid mass, a light tap being all that is necessary when a rapid explosion is required. So, again, as the friction of small shot is greater than that of large, the former requires more powder than the latter. Short barrels require finer powder than long, which latter allow more time for combustion, and if fine powder is used with them they will expend a greater quantity of it beneficially, though with a greatly increased recoil. Taking all these points into consideration, the following table will be serviceable:

Weight of gun.	Bore.	Charge of powder.	Charge of shot.
7½ lbs.	12	2¾	1¼
7¼ lbs.	12	2¾	1¼
7 lbs.	14	2¾	1¼
6¾ lbs.	14	2½	1
6½ lbs.	16	2¼	¾

*Having fixed upon the charge, either from theory or from experiment with the particular gun, let it be brought out thoroughly clean, and then proceed to load as follows. First, put on a pair of caps, then explode them, and holding the gun perpendicularly, with the butt on the left foot, at half arm's length, and the right lock facing you; pour down each barrel the proper charge of powder, *beginning with the left barrel*, which is then placed farthest from you. Next put in two greased felt wads, and ram them gently home, giving one smart (but not violent) tap to each, to drive the powder to the nipples. After this put in the charges of shot, again*

beginning with the left barrel, and holding the pouch at an angle so that the hand is not over either barrel. A cardboard wad is then put into each muzzle, and the ramrod is again used to push them carefully home, but not to rap them, as before; the less pressure used on the shot the better, so long as the wad barely keeps it in its place. Lastly, replace the ramrod (or loading rod); and, taking the gun up in the left hand, with the muzzle pointing downwards, halt cock it, and removing the exploded caps, put on fresh ones, pushing them well down on the nipples with the thumb. By adopting this method the least possible amount of danger is incurred; the only risk being from a piece of tow having been left in the breech, which may take fire, and communicate it to the powder as it is being poured down, when, if the powder flask is not properly constructed, an explosion of its contents may take place. On the other hand, if the above precautions are not taken, even if the flask is ever so sound, it may be blown through the hand with great violence. In loading either barrel while the other is loaded, take care that the one containing the charge is at half-cock, while the other has the hammer down, as left by its discharge. In this case the most prudent plan is to turn the gun so that the loaded barrel is the farthest off from the person; but if the butt is put across the foot, and the hand is not held between the gun and the body, which it never ought to be, this is not of any great importance.

In order to accelerate the loading of these guns, or to increase their powers, several contrivances have been invented. Of these the most ingenious are the Rackheath and Hall's two kinds, which act on somewhat different principles, and Eley's as well as Joyce's cartridges for increasing the range of the gun; each being described as follows:—

(a) *The Rackheath* consists of a case of common cartridge paper, at the bottom of which is placed an ordinary wad, the edges of the paper being gummed over it. Into this the shot is poured, then a felt wad, next the powder, over which the ends of the paper are turned. Lastly, a disk of paper, having a piece of tape attached to it, is gummed to this all round, taking care not to wet the powder in doing this. When this is done the cartridge is complete, and may be carried in the

pocket till it is wanted, when the tape being pulled the disk comes off, leaving the powder exposed, and then the whole, being inverted, is put into the muzzle and rammed down with a final tap.

(b) *Hall's* first cartridge is made in the same way excepting that, instead of the tape, a disk of paper is attached to a ring of metal, which, as the ramrod is applied, prevents the case from going down the barrel, but allows of the powder and shot being rammed down at one operation.

(c) *Hall's second* cartridge is much more ingenious than either, but like many most clever inventions is radically bad, for the reason which will presently be given. It consists of a brass tube which fits the interior of the barrel, and is pushed down for its whole length, being prevented from going further by a rim or turn over. This tube is loaded as follows. A thin wad has a fine thread attached to it, and is pushed down to the bottom, leaving the thread fixed over the upper lip by the thumb; the powder is then poured in; next follows a felt wad, then the shot, and finally a card wad, with the name of the inventor on it. When thus prepared the thread is cut off close and the cartridge is ready for use. When the metal case is put into the barrel, a ramrod drives down the charge, but in doing this the thin wad is held suspended by the thread, allowing the powder to pass it, and finally lying between the powder and the felt wad. But in order to use this cartridge the wads must of necessity be smaller than the barrel by the thickness of the metal cartridge case, and thus *there is always danger of the charge becoming loose*. Although, therefore, there is great ingenuity displayed in the invention, I cannot recommend its use in the field.

The two cartridges just described (*a* and *b*) may, however, facilitate the loading of the percussion gun to a considerable extent.

(d) *Eley's and Joyce's patent wire cartridges* are used for a different purpose, having reference to the shooting powers only. The circular of Messrs. Eley is here annexed, its statements being verified by my own experience as well as by that of most practical sportsmen. The cartridges of Joyce and Co. are similar in their construction, but Messrs. Eley have the credit of the invention.

“ These cartridges are composed of a cage of wire, inclosed in a thin paper case, with a wadding attached, fitting the bore of the gun. The shot are placed within the wire; and the principle of their action is extremely simple. On leaving the gun, the paper is torn in pieces, and the shot immediately begin to quit the case, passing through the meshes of the wire net. The wire is carried forward with the shot so long as any remain in it, and, when empty, falls. Thus, the royal cartridge, when fired through a paper screen placed at 10 or 15 yards from the gun, will be found to have spread some of its shot like a loose charge, while the remainder will have been carried through the screen in the form of a ball; and if a target had been placed behind the screen at 25 yards, the wire would be found to have dropped short of it, and the shot entirely separated. The green will carry their shot further.

“ The royal are intended for the second barrel at the commencement of the season, or the first barrel when game is wild; they make a good spread of shot 20 yards from the gun, and will kill 20 or 25 yards further than a loose charge.

“ Those in green cases are for wild fowl and very long shots; they will kill twice as far as a loose charge.

“ The universal shot cartridges are intended to supersede the use of the shot-belt; they are composed of shot packed in a paper case, between layers of soft bone-dust, with a wadding attached, fitting the bore of the gun. They contain no wire, thereby removing the objection (however fallacious) sometimes urged against the wire cartridge. On leaving the gun the paper is torn in pieces, and the shot at once separate, acting precisely as a hard-hitting loose charge, but much more uniform. Balling, or clubbing, at any distance is impossible, the shot being quite as much separated, and covering as large a space, even at the distance of five yards from the gun, as if loose shot were used. And whatever is the performance of a gun with loose shot, a cartridge of equal weight will put twenty-five per cent. more shot in the same space at 40 yards, and with great additional strength; so that a gun that will throw loose shot strong and close is improved in the same degree, making it shoot in a very superior

manner—affording a greater chance of killing, because, in addition to the closeness, they cover a larger surface in consequence of every shot being brought into action.

“The manufacturer having only put forth statements, the accuracy of which any sportsman may test for himself, solicits a few careful experiments, in order that they may be used with confidence.

“The following advantages may be enumerated as applicable to all of them:—

“They keep the gun free from lead, and the unpleasant recoil consequent therefrom, during the longest and hottest day’s shooting.

“Much smaller charges than common may be used.

“The loading is performed in half the usual time, the only wadding necessary being attached to the cartridge.

“When once rammed down, they are not so liable to rise or get loose by the firing of the other barrel.

“To those who prefer light charges they are invaluable; a cartridge containing 1 oz. of No. 7 shot is far more effective than a loose charge of $1\frac{1}{2}$ oz. of No. 6. This will be found a great acquisition in the early part of the season.

“It has long been well known to sportsmen of discernment, that the pellets constituting the loose or open charge are scattered too much, and thrown with a very disadvantageous irregularity, besides a considerable portion of the charge being very defective in point of strength or projectile force, about one-fourth of it being rendered nearly useless by friction in passing up the barrel. These great defects induced innumerable plans and experiments from time to time with the view of effecting the great desideratum of lessening the spread, and accomplishing the dispersion with some degree of precision—none of which had been found to act with certainty until the discovery of the patent wire cartridge.

“The only real objection ever raised against them was their liability to ball; but this defect has been long remedied, in proof of which the patentee has received the highest encomiums from most of the first sportsmen of the country, and all the leading authors of the present day who have written on the subject of shooting.

“The patentee submits the following particular statements

as to the comparative effects of the loose charge and the cartridge, with the assurance that he states nothing but what is borne out by the evidence of facts, being founded upon the repetition of careful and accurate experiments, which renders any material error utterly impossible.

“Comparative Effects of the Loose Charge and the Cartridge.”

LOOSE CHARGE.

Charge $1\frac{1}{2}$ oz. of No. 6 shot and $2\frac{1}{2}$ drachms of powder. Target 2 ft. square. Distance 40 yds. Different guns will vary from 60 to 100 pellets in target, and seldom put more than 25 shots through 24 sheets of thick brown paper. Should any gun exceed this statement in its power of shooting, the strength of the cartridge will increase in the same proportion.

CARTRIDGE.

The same weight will vary from 120 or 200 in target, and from 50 to 100 through 24 sheets of thick brown paper.

STRENGTH.

If additional strength be required, more powder must of course be used, which spreads the shot so considerably that there is as much lost as gained by the increase.

An increase of powder causes the cartridge to shoot thicker as well as stronger, so that its efficiency may be increased at pleasure.

FOULNESS AND RECOIL.

As the barrel becomes foul the recoil increases, in hot weather particularly. This also much decreases the force of the discharge.

The recoil, even at first, is not near so great as that of the loose charge; besides which it never “leads” the barrel, and consequently never deteriorates the shooting of the gun.

SPREAD OF THE SHOT.

Generally in irregular patches or clusters (particularly in close shooting guns), leaving frequent spaces through which a bird might escape.

Always much more uniform—a fact ascertained by Captain Ross once killing 79 out of 80 pigeons, trapped at 30 yards. The chances were that with a loose charge one at least out of every dozen would have escaped from this cause alone.

LOOSE CHARGE.

As the second barrel acts with no greater force than the first, few sportsmen can kill a double shot if the birds rise above twenty yards.

CARTRIDGE.

SECOND BARREL.

By using the loose charge in the first barrel and a cartridge in the second, or, when game is wild, a Royal cartridge in the first barrel and a Green in the other, a second shot may be taken with as good a chance of success as the first.

EFFICIENCY OF THE WHOLE CHARGE.

About one-fourth of the charge is so injured in rubbing up the barrel as to be quite useless at any distance, and the whole is so jammed into angles as to entirely neutralize any value supposed to be attached to its "patent" roundness. The unequal force of the shots may be ascertained by firing a loose charge, at 100 yards, at a thin fence; the notice of its arrival at the mark will be continuous, like a *feu-de-joie*.

All the pellets of the shot retain their certain roundness which is the cause of their being found so much more effective in the field at long distances than can be shown at a target; all the shots being propelled with equal force. If fired against a fence at 100 yards, the arrival of the shot will be simultaneous.

FIRMNESS IN THE BARREL.

Loose charges are very liable to move or rise in the second barrel on the discharge of the first, when the wadding will turn round, and the shot will fall out; or, with an easy-fitting or soft wadding, the charge will occasionally rise several inches in fifteen or twenty shots, and thereby endanger the safety of the barrel.

Although the cartridge will rise a little after numerous discharges, yet it is not nearly so liable to it as the loose charge; and indeed, when the barrel becomes foul, it is almost impossible. (*It is, however, a necessary precaution in both cases occasionally to try if the charge be risen when loading the other barrel.*)

MOST USEFUL SORTS.

For game early in the season and battue shooting	Universal, No. 5 or 6.
For snipe and other small birds	Royal, No. 8.
For game (second barrel early in the season, and first barrel when game is wild)	Royal, No. 5 or 6.
For second barrel when game is wild	Royal, No. 4.
For wild fowl (single birds beyond 60* yards)	Green, No. 3.

* If within this distance one of the others would do better.

For wild fowl in flocks, or grouse in packs at great distances	Green, No. I.
For wild swans	Green, SSG.
For wild peacocks, bustards, turkeys, &c., in India, Canada, &c.	Green, No. 1, to AAA.
Random shooting at deer, or large game of any description, where the sportsman has not the opportunity of using the rifle	Green, SG.

The following rules should be carefully remembered and followed, in order to prevent accidents during loading:—

Rule 1. Always uncock the loaded barrel of your gun after discharging the other. The loaded one should be left at half-cock, and the other with the striker down on the nipple.

Rule 2. In loading the last-discharged barrel, always keep the loaded one farthest from the hand.

Rule 3. Never put the caps on before loading—the cock may slip, even with the best lock. Moreover, the powder is prevented from reaching the end of the nipple.

Rule 4. After the caps are on and pushed home, never leave the cock down on them, as in this position a blow on the cock, or even on the butt, may occasion an explosion.

Rule 5. Never point the gun at any living object during cocking and uncocking, when the cock is very apt to slip from the hand of a cold or awkward person; and to avoid all danger of this, keep the muzzles pointing to the ground at an angle of 45°.

CLEANING.

To clean the percussion gun in all its parts, it is necessary to be able to take it to pieces, but for common purposes all that is required is to wash out the barrels and oil the locks. A *turnscrew*, *nipple-wrench*, and *cleaning-rod* are the tools for all but taking the lock to pieces, which requires in addition a *cramp*.

To clean the barrels, first take them from the stock by pulling back the stop from the eye or eyes in the fore-end of the stock; then having half-cocked the locks, lift out the barrels, take out the nipples with the wrench, put them on

one side, and proceed to wash out the barrels. For this purpose take the cleaning-rod, which is armed with a brass roughly-notched end on purpose, wrap round this some tow, and then placing the barrels muzzle upwards in a bucket half full of cold water, proceed to wash them well out by working the tow up and down in them. Remove the tow in a short time, and apply fresh as long as the barrels stain it, then take them out, pour some boiling water through them, and set them to drain by the fire till quite dry. Lastly, take a piece of *rag (not tow)*, wrap it round the cleaning-rod, touch it slightly with the proper oil (neat's-foot clarified by suspending pieces of lead in it for two or three months), then pass it up and down each barrel once or twice, oil the inside of the screw in which the nipple fits, oil the nipple, and reapply it with the wrench, when the operation is complete.

To clean the locks, first remove them by unscrewing the head of the screw, which is just in front of the hammer at half-cock, when the two locks will come out readily, both being secured in their places by this long screw passing through the stock, and called the "side nail." The inside of the lock is then exposed, as shown in Fig. 28, page 238. If any grit has got in, which it ought not to do in a well-fitted lock, it may be removed by an oiled feather, or if the members are rusted by damp, they may be wiped with a piece of leather, then applying just enough oil to lubricate them, the locks are restored to their places and the side-nail screwed home. Sometimes, however, from neglect, the various members may have become so rusty, that they require to be taken to pieces, which may readily be done by cramping the main-spring at full-cock, serewing the little cramp sold for the purpose on to the spring, and keeping it on while the various screws shown on the bridle are removed, when the swivel is unhooked from the spring, and all the parts are loose, and can be cleaned separately. Should the plate be so rusted that the spring cannot play freely upon its surface, the latter also must be removed by inserting a turnscrew under it, and lifting out, when the plate being cleaned, it may be restored to its place. Unless, however, the owner of the gun has some considerable mechanical skill, he had better not at-

tempt to clean his locks, but should give the job to his gunmaker.

If the barrels are leaded, a wire brush is attached to the cleaning-rod, and with this they are rubbed up and down with the aid of a little silver-sand, if necessary, till the lead is all removed. There is, however, in this process, great risk incurred of spoiling the barrels, and if really necessary, it is better to allow the gunmaker to remove the lead.

THE GUNCASE AND CONTENTS.

The guncase may be of wood or leather, or of the former within the latter material. Patent leather gun-cases are, however, now the most generally used, and as they are cheaper as well as lighter, they are in my opinion better than wood. They should contain, in addition to the gun, a nipple-wrench containing two spare nipples, powder-flask, shot-pouch, cap-holder, dog-whistle and whip, wad-punch, and a supply of wadding, besides such cartridges as are approved of if they are used. In addition, there should be for cleaning purposes a turn-screw and cleaning-rod, with tow, linen, and oil in a small metal bottle; the proper sort for all but the locks being neat's foot oil clarified by suspending in it pieces of lead for some months. The locks should never be touched with any but gunmaker's oil, usually known as Wilkinson's. All these articles should be arranged in compartments, so as to avoid friction on the gun.

PRICE.

The price of percussion double guns varies from 4*l.* or even less, to 50 or 60 guineas, which Purdey, Lancaster, Manton, and one or two other fashionable London makers, obtain for their articles. At the lowest price here mentioned the iron used in the barrels would be twopenny, or perhaps sham damn. Keepers' guns are sold at all prices; but a good useful one, with barrels of charcoal iron, should cost from 10*l.* to 15*l.* No safe gun can be purchased for less than 20*l.*, if tolerably well finished, and none, in my opinion, ought to cost more than 35 to 40 guineas complete in case, and I believe that for the latter sum as good a gun as can be

built may be obtained. At the same time, I confess that if I were offered my choice, regardless of price, I should select a gun of Mr. Purdey's make, believing that he is supremely careful that every part is of the very best quality, and that the workmanship is the best which can be obtained by money or care. I have reason to believe also that all his guns are actually tried at brown-paper targets, those only being passed which perform to his satisfaction. But though I thus place them at the head of the list, I would not give 5*l.* more for a gun of his make than for one built by Pape of Newcastle, or Dougall of Glasgow, or Henry of Edinburgh, or O. Smith of Derby, all of whom turn out guns which handle well, look well, and *perform well*, and who charge from 35*l.* to 40*l.* for a double gun in case complete. Prince and Green, Fuller, Jackson, Reilly, and some others in London, may be mentioned as selling excellent guns at about the same price, or perhaps a trifle higher, and among these I would specially call attention to the gun patented by Mr. Prince, of the firm of Prince and Green, on the principle of elevating the left barrel higher than the right, which has been already alluded to at page 223.

CHAPTER III.

BREECH-LOADING GUNS.

GENERAL PRINCIPLES—THE LEFAUCHEAUX GUN—VARIOUS MODIFICATIONS OF IT—THE NEEDLE-GUN OF NEEDHAM—LANCASTER'S COMBINATION OF THE TWO—COUNT CHATEAUVILLIER'S GUN—CHOICE OF BREECH-LOADER—LOADING OF CARTRIDGES—CLEANING.

GENERAL PRINCIPLES OF CONSTRUCTION.

It has already been mentioned that there are some two or three defects in the muzzle-loader, consisting in slowness and danger of loading, and in the amount of leading, to which it is liable. To obviate these, it has been proposed in

various ways to load at the breech, which may be effected in from a quarter to a sixth of the time occupied in the old plan; and with less danger, because the hand is never over the muzzle at any time, and, till the breech is closed, if an explosion should take place, it is comparatively harmless. Leading also is almost entirely got rid of, and there is little or no fouling—so that at the end of a day's shooting the gun shoots as pleasantly as at the beginning. Moreover, the cleaning is a very simple process, and the eye at once detects in the Lefauchaux gun the slightest amount of foulness, which a few passes of the clearing rod will easily get rid of. In some, as in the needle-gun, there is a constant necessity for cleaning the locks; but even this does not apply to the Lefauchaux pattern. Whether or not breech-loaders shoot as well as muzzle-loaders remains to be considered; but all the qualities of the several patterns will pass under review in the following pages.

THE LEFAUCHEAUX OR FRENCH CRUTCH GUN.

For about twenty years this gun has been commonly used in France; but until the year 1851 it was almost unknown in England. At that time, however, Mr. Lang, of Cockspur-street, London, took it up, and since then his example has been followed by nearly all the gunmakers in the kingdom, so that at the present moment there are probably five of this make sold to one of the ordinary muzzle-loader of best quality.

In this gun, when it is loaded, the general appearance closely resembles the ordinary muzzle-loader—the chief difference perceptible to the eye being the standing up of a small brass pin between the false breech and the barrel, instead of the nipple and its cap. This pin is struck by the hammer in the usual way, and by the blow given at its internal end to a cap inserted in the cartridge the powder is exploded. In addition to this variation, there is also a lever fixed below the breech end of the barrel or barrels, which admits of being turned sideways, and in so doing liberates them, and allows of their being raised at the breech end, and lowered at the muzzle, upon a strong hinge, as shown in the accompanying engraving of one of Messrs. Reilly's guns, shot at the *Field*

trial of 1859. Here the lever (fig. 33 *a*) is turned to the right, by which a hook is withdrawn from the notch in the

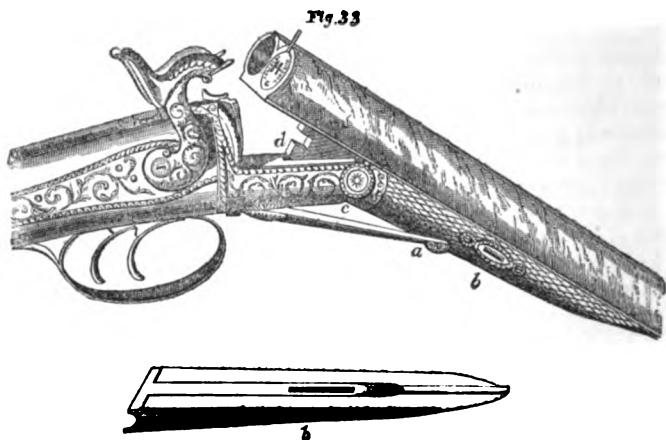

THE LEFAUCHEAUX GUN. (ONE THIRD SIZE.)

under surface of the barrels at (*d*). The stock where it is pierced by this lever and hook is entirely of iron; and in its fore end is a strong hinge (*c*), composed of a circular bolt attached to the stock, and of a corresponding socket fixed to the barrels, which may be opened by removing the part (*b*), on withdrawing the slide, when it comes away and appears as separately shown. The lever or crutch and the hook are so contrived, that when the gun is closed again with a snap, the former is replaced, and lies under the barrels—requiring sometimes, but not generally, a slight force to be applied to it to jam it quite home, and so render the breech secure. There are various modes of carrying out this object; but one of the most simple is a square stud beneath the breech end of the barrels, which is raised by the lever, and just frees them from the false breech, after which their own weight carries them down. On returning them to their places, the pressure on this stud again acts on the lever, and sends it home or very

nearly so. The best form of lever is that which is given in fig. 34, sketched from one of Messrs. Prince and Green's guns, in which it is shown at *b c*, as covering the trigger-guard (*a*); but the sketch being taken from the opposite side,

Fig. 34.

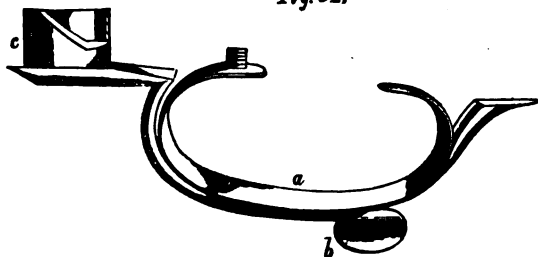

BACK-ACTIONED LEVER. (HALF SIZE.)

does not give a clear comparative view of the two. In this shape its own weight has a tendency to restore it nearly to its place, where the right hand is ready to carry it quite home, and considerably increased quickness in loading is acquired. As the gun lies thus opened, it will be seen that the interior of the barrels is exposed, and that the false breech, which completes them, is a flat surface, so as to render them when closed more or less perfect cylinders open at one end, and without any contracted chamber like that in the breech of the muzzle-loader at the other. But, on the contrary, the cylinder is enlarged to a considerable extent for about two inches and a half; whilst at the end of this a shoulder, more or less bevelled off, presents itself. This chamber is intended to hold a cartridge made for the purpose, and accurately but loosely fitted to it. Great experience is required in properly adjusting this slightly conical chamber to its contents; and it is here that inferior makers generally fail. If of a bad shape, the cartridges stick after explosion, and occupy much time in their removal; but if it is well made, they come out with great ease, and a sticking cartridge very rarely occurs in good guns of this make.

The following engraving shows a section of the chamber, with a loaded cartridge case in it, by which it will at once

be seen that the two together complete the cylinder, and that the interior of the paper cartridge corresponds with the line of the interior of the metal barrel farther on. There

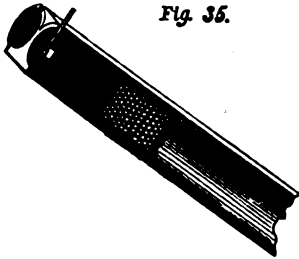

Fig. 35.

SECTION OF LOADED CARTRIDGE AND CHAMBER. (HALF SIZE.)

is generally a small interval at the point of junction, but there is no necessity for this if the cartridge case is cut of the proper length, yet even if there is, it seems to be of little consequence, as far as can be ascertained from practical experience. When the gun is closed, this case is supported by the false breech, and all escape of gas is prevented by the explosion swelling out its sides against the chamber. It is found after shooting that few cases are burst, and therefore if there is any escape, it must be between their external surface and the chamber which, as I said before, is made close by the expansion of the former. Practically it results that there is no escape whatever, as is readily shown on an examination of the gun after several discharges. Indeed even by the side of the pin there is little or no stain; and, as compared with that which takes place out of the nipple-hole of the muzzle-loader, it is *nil*. In theory, therefore, it would be concluded that this gun would shoot stronger than the percussion with a chamber of the same make, for it would not be fair to compare it with one whose breech is hollowed out into one of the forms known as those of Manton or Wilkinson. But in practice it is found that the shooting is not so strong, and that, from some cause or other, it requires a larger quantity of powder to produce the same effect as the muzzle-loader. This is variously estimated at from a quarter to three-quarters of a drachm, some makers even going so far as to require the latter additional weight of powder. Whether this loss of force arises from the shape of the chamber, or from the compressible nature of the cartridge case, or from any occult cause, is open to discussion, but that it really exists is an indisputable fact. The advocates of the muzzle-loader point to it as a defect, some

arguing that there must be an escape of gas, and others that the shape of the cartridge is the cause; but if the additional quantity of powder will only give the desired result, I cannot think the loss of power of any real importance. As far as my experience goes, however, in spite of this additional charge, the breech-loader still shoots somewhat less strongly than its rival, but not to any extent sufficient to counter-balance its manifest advantages. This will be made more clear in examining the results of the *Field* gun trials of 1858 and 1859, the latter of which will be given elsewhere.

Such being the principle of this gun, it remains now to consider how these several parts are constructed to the best advantage, and in doing this, it will be necessary to examine each of the parts in detail.

The barrels of the breech-loader are forged exactly in the same way as for the muzzle-loader, the only point necessary to be attended to being that they shall be somewhat stouter at the breech-end. No greater length is required, except for Needham's and other needle guns; and indeed, there is no reason why any ordinary barrel before it is tapped for the patent breech may not be used. Here, however, the difference in the make begins, and the barrel-maker has to braze on with great care two lumps of iron to the lower sides of the barrels, one of which serves to make the notch into which the lever slides to keep the barrels firmly in their places, and the other forms about three-fifths of the socket in which the circular bolt fixed in the stock revolves. In order to understand the exact form of the bolt, a gun on this principle must be examined, and moreover as scarcely any two makers adopt the same shape, the description of one would not suffice for all. In all cases, however, the principle of the lever in combination with the inclined plane is employed, and by their aid the notch in the lower part of the barrel is firmly brought down and held in apposition to the stock, two notches, or what is called "a double grip," being the strongest and best plan. On removing the slide in the front of the stock, the fore end comes readily away, and in the part next the hinge, a segment of a circle will be seen formed which completes the socket of the bolt. The barrels may now be lifted out of their bearings and removed from the stock altogether and

they are only firmly held there when this portion of the stock is replaced and re-bolted. But besides the lumps brazed on to the under part of the barrels, and cut to the proper form for the purpose of taking the bolts, the breech end is also chambered out carefully, so as to receive the cartridge case of the size intended to be used with freedom, but at the same time not too easily. The rule is, that so long as the cartridge will not fall out by its own weight, it cannot be too loose, and the pinch should be most at the end farthest from the breech. In other words, the chamber should be slightly conical, and its shoulder should be bevelled off at an angle of about 45 degrees. Barrels for breech-loading guns do not require to be much opened behind, the difference between the diameter of the cartridge and that of the barrel being nearly sufficient to detain the charge until all the powder is burnt. This probably is one reason why the recoil is so slight in proportion to the increased charge of powder, for though it does not appear that the breech-loader actually "kicks" less than the muzzle-loader, as is affirmed by many, yet its recoil is not certainly greater in proportion to the extra powder. A slight "relief" will be necessary to obtain a good pattern, and most of these guns are so bored for about six inches from the muzzle, but this is regulated in each case according to the shooting on trial at the gunmakers' iron plate.

The cartridge case is next to the barrel in importance, though not being an actual part of the gun, it might at first sight be considered as an accessory only. Still the breech-loader is wholly useless without it, and therefore it is better to consider it as an essential. It consists of a cylinder of stout brown paper, from two to four inches long, open at one end and closed at the other by a brass capsule which overlaps the sides for a quarter of an inch, and is lined by a pasteboard wad $\frac{3}{8}$ ths of an inch thick. In the centre of this wad is punched a hole of an oblong-square shape, lined with brass, and passing through the edge of the capsule and through the substance of one section of this wad is a small brass pin, one extremity of which stands up for half an inch above the level of the outside of the capsule, and the other enters the little chamber in the wad, where it has a percussion-cap fitted on it. By this arrangement, a blow on the outer end of the

pin explodes the cap, which is prevented from giving way by the firm surface opposed to it, consisting of the side of the hole in the wall, which is, as before described, lined with brass. The pin also, in passing through the wad, is held so safely that no gas escapes, and the whole of the gaseous contents of the cartridge are driven out of its open end, where they at once enter the cylinder of the barrel.

These cases are now made of two sizes—12 and 16—whatever may be the gauge of the gun they are intended for; and although the numbers 15 and 14 are stamped upon the cases sold by those gunmakers who are fond of mystifying their customers. They were only manufactured in France, where most of our gunmakers bought them with their names stamped. But Eley now sells a considerable number of his own make, really turned out of hand by machinery in this country. At first these were of inferior quality, but they are now produced quite equal to the best made in France. The price is 50*s.* per 1000 for 16-gauge, and 3*l.* for 12, and as they contain a substitute for the cap of the ordinary percussion gun, the cost of these must be deducted, so that the actual additional outlay is, as near as may be, a halfpenny per shot, if a stock of these cartridges is laid in. Now, putting the average value of each head of game at 2*s.*, if only two per cent. additional are killed, this increased expenditure will be paid for, and as I think it cannot be denied by those who have tried these guns that this estimate is too low, instead of occasioning a loss, they are really entitled to be considered as producing a saving. Few sportsmen would probably regard the trifling extra cost, even if it were not reimbursed, but as I believe that even on this ground the system can be shown to be advantageous, it is quite as well to state the question as it really stands.

The locks of the Lefauchaux gun are necessarily made "back actioned," because there is no room for the bar, the place of which is occupied by the lever and bolt. I have already stated that the bar-lock is now preferred by most sportsmen, but the disadvantage of the back action is so trifling as to be scarcely worth mentioning. The hammers

are slightly lighter and the springs weaker than those of the percussion gun.

The stock not being placed with the butt on the ground when loading, does not require a heel-plate, though most gun-makers add one for the sake of appearances. In general shape it resembles that of the ordinary gun, that is to say in length and in the amount of bending and casting off. But it is completely divided in the middle from the necessity for an iron support for the false breech and bolt, which will be presently described together.

This false breech and bolt are so arranged as to connect the stock with the barrels at the will of the shooter, and they must be of sufficient strength to resist the strain which is put upon this part. There are several modes of making the connexion, but the most common is that represented in the engraving at page 256. Here a lever is placed beneath the stock, and, by turning it to the right, the wedge-shaped hook is drawn out of the notch which it previously occupied in the lower part of the barrels close to the breech end. This plan is open to the objection that the hook is at some distance from the breech, and that consequently the spring of the metal allows the barrels to rise when the explosion takes place, not only causing an escape of gas, but also a deviation from the correct aim previously taken. To obviate this, a second hook has been added, commonly known as the "double grip action," which seizes hold of the projection beneath the barrels behind as well as before, and effects a very much more secure union between them and the false breech. In guns of less than 12-bore it is scarcely necessary, as the single grip is sufficiently powerful for them; but when these breech-loaders are made of a 10-bore or even larger it will be found useful, and also for rifles, as I shall hereafter show. As regards the escape of gas, I believe that none takes place under ordinary circumstances, except by the side of the brass pin of the cartridge, and this is proved on an inspection of the cases after firing them, when their outside will be invariably found clean, unless they have burst, which good ones rarely do, on the first time of using. The objection is in my opinion more theoretical than practical, but if any plan can be discovered which will do away with this

objection, it is so much gain to the cause of this breech-loader. I believe that the "double grip" is so strong that it makes this breech almost as solid as that of the old-fashioned gun; and the non-occurrence of any escape of gas, as proved by the absence of any stain on the metal, shows that this view is correct. Whether this is effected by the aid of the cartridge or not is of little consequence, for the fact remains the same that the breech, when put into use, stands the test to which it is exposed.

Such are the various parts of this very ingeniously-contrived piece of mechanism, which when put together forms the most useful sporting shot gun hitherto invented, as far as I know. It is capable of being packed in a gun-case exactly of the same shape as the ordinary kind. In order to take the barrels out of the stock for this purpose, the slide is removed in the usual way, which releases the piece of wood corresponding to the front end of the stock, and thereby takes away a part of the hinge. By now turning the lever to the right the socket in the barrels may readily be lifted off the hinge bolt; and in replacing them the reverse method is to be adopted. Some little knack is required in doing this; and if the sportsman is not possessed of an average amount of mechanical skill, it is better to take a practical lesson before making the attempt.

VARIOUS MODIFICATIONS OF IT.

The first modification of the plan of closing the breech adopted in the Lefau-

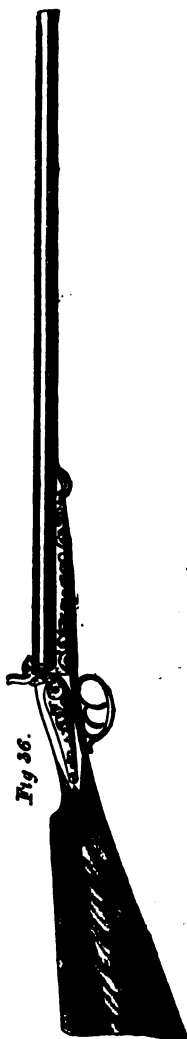

BASTIN'S BREECH-LOADER.

cheaux gun, has been very lately made in Belgium, its chief peculiarity being part of a patent taken out some years since in the name of Count Chateauvilliers. It is now known as *Bastin's breech-loader*, and was tried under that name recently at the *Field gun* trial held at Hornsey

Wood House, where, however, it performed badly. The arrangement has, however, nothing to do with the shooting, but only with the closing of the breech; and I am informed by the gentleman who sent it, that it has since shot extremely well. The improvement has been suggested by the objection which has been

made to the crutch gun of Lefauchaux, that in the explosion it is apt to open between the barrels and

the false breech. The Bastin principle is also said to obviate the wearing away of the bolt or hinge connecting the two most important parts, which would of course, if it did take place, occasion an open joint between them, and consequent escape of gas. A third advantage is contended to exist, in its being so made as to withdraw the cartridge case after each discharge, by the act of opening the barrels to load either of them afresh. Whether all, or indeed any, of these praiseworthy intentions are successfully carried

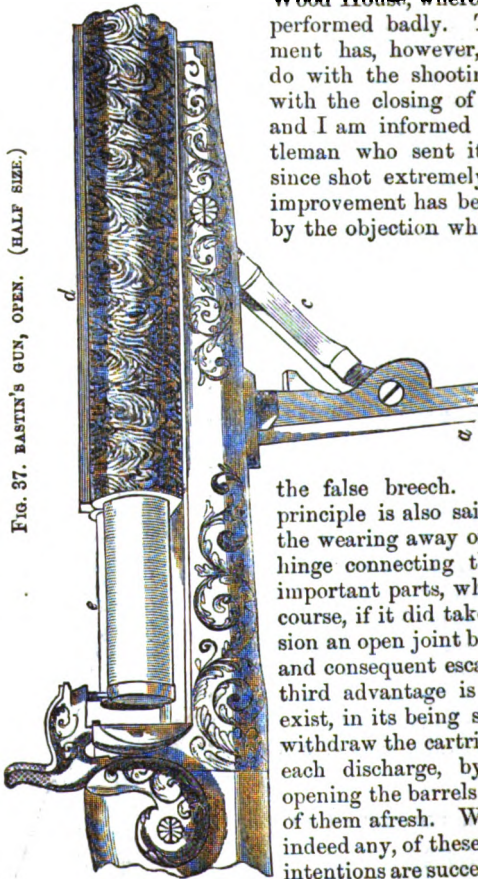

FIG. 37. BASTIN'S GUN, OPEN. (HALF SIZE.)

out, remains to be proved; and I shall endeavour to enable my readers to judge for themselves. The annexed illustration shows the gun open, in effecting which the barrels slide forwards on depressing the compound lever (fig. 37 *a*). This, acting on the branch *c* fixed to the fore end of the stock, while the lever is attached to the barrels, causes the latter to slide forward exactly in proportion to the depression of the lever till they assume the position indicated in fig. 37. Here the cartridges are represented at *e*, as if the gun had just been discharged, for after one is exploded the hammer is left down, and there being a hole in its striking face, when the barrels are drawn forward, the pin of the cartridge enters this hole, and so it is expected that the cartridge will be left behind, as shown in fig. 37 *e*.

In order to show more clearly the nature of the slide, a view of it from below is appended (see fig. 38), in which *d* represents the barrels, *c* the branch of the lever fixed to the stock, *a* the lever, and *b* the catch in

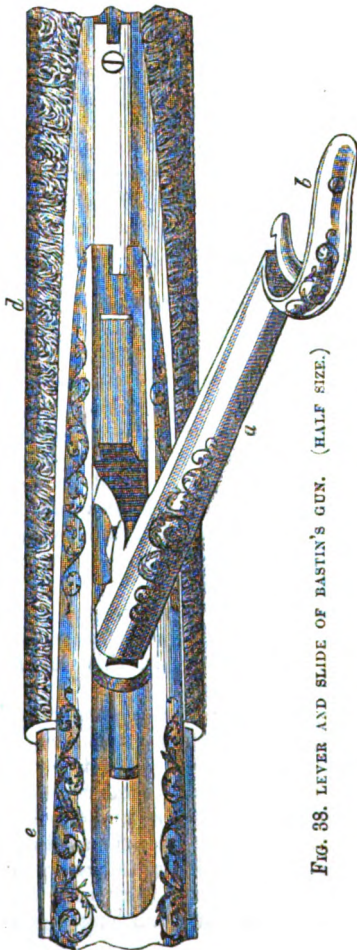

FIG. 38. LEVER AND SLIDE OF BASTIN'S GUN. (HALF SIZE.)

its extremity, which keeps it in its place when ready for use. On referring to the small cut of this gun (fig. 36), this spring will be seen within the hook by which the lever is laid hold of; and it is so arranged that the finger, before it can depress the hook, must release the spring-catch.

Such is the construction of this gun, and doubtless in theory it is very beautiful; and in practice the mechanism acts particularly neatly, unless the cartridge sticks, when the dead pull of the lever, in conjunction with the hold on the pin being at its extreme point, very frequently tears away the capsule from the case, which is left behind. This occurred seven times out of a dozen shots which I fired from this gun; and I believe would generally happen, because the action is radically faulty. In order to remove a sticking cartridge without injury two things are necessary; firstly, the pin must be laid hold of close to the barrel, and pulled in the direct line of the axis of the latter; and secondly, this must be done with a smart blow or quick jerk, and not with a steady powerful pull, as is done with the lever of the Bastin gun. It is possible, however, that the contrivance may be improved, and that this objection will be overcome; but I should also be afraid that the slide would be liable to become rusty from damp, and then the lever would be unable to move forward the barrels. This last, however, is only a theoretical objection, while the other is founded upon what has actually occurred in practice.

The cartridge case employed is of the ordinary Lefauchaux kind; and indeed in all other respects but the mechanism adopted in opening it, this new invention is similar to the French crutch gun.

In addition to the objections which I have alluded to, consisting in the inefficient delivery of the cartridge cases, and the tendency of the slide to stick from rust, the following may be urged as of some considerable importance:—firstly, the opening for the admission of the cartridges is only made of exactly the same length as they are themselves, and hence there is some little difficulty in introducing them; and secondly, there is no means of *readily* taking the barrels from the stock, so that a full length gun-case is necessitated.

To obviate these defects in the Bastin breech-loader, without losing the manifold advantages of the Lefauchaux gun, several plans have been introduced and patented, which I shall allude to in the order of the dates of the inventions. One of the most simple of these was brought out last year by Mr. Adams, of King William-street, London, and it answers extremely well in all respects, but the increase of expense incurred for cartridges. Supposing that he wants a 12-bore gun, he takes a pair of barrels of that gauge, and fits them up on the ordinary Lefauchaux plan, with or without the double grip action, *and without chambering them at all*. He then takes a 16-bore cartridge, of Eley's make (which just fits the 12-bore barrel unchambered), and cuts it off to the length which will hold the charge of powder and a felt-wad. On the top of this he gums an Eley's universal cartridge, and in that state uses the two together, with a considerable gain in penetration, in consequence of the adoption of the second cartridge. A wire cartridge may be substituted for this, at the option of the shooter, when a still longer range is desired; but loose shot cannot be employed in any case. Irrespective of the cost and trouble the plan is undoubtedly good, but to most people these will be considerable objections.

Mr. Penryn Aston, barrel-maker, of London, *Mr. Dougall*, the well-known gun-maker, of Glasgow, and a *Mr. Erskine*, of Scotland, who is not connected with the gun trade, have each patented a plan, intended to combine the sliding action of the Bastin gun with the hinge of the Lefauchaux, by means of an eccentric bolt, on which the latter turns. *Mr. Erskine's* is confined to this alone, and I believe has never been carried out in practice; but the two former inventions combine also two central cores on the face of the false breech, which project into the barrels, and thus have a tendency to keep them from rising during the explosion. Until the publication of *Mr. Dougall's* plan, I had never heard of that of *Mr. Penryn Aston*, but his patent certainly bears a prior date, and if the principle of the one interferes with that of the other, this would entitle him to claim the exclusive use of it; but a court of law only can decide the question, and to this I must leave the settlement of the knotty point. In

any case, as Mr. Dougall has gone to great expense in bringing his invention before the public, it would be rather hard upon him to be deprived of the fruits of his labours by a person who has done nothing to forward it, beyond obtaining the patent. The Liege gun-makers, as well as some of the first of the London trade, have taken up the invention, and must therefore be supposed to think highly of it; but never having seen the gun tried I must reserve my opinion upon it. At the same time I have no hesitation in stating that, as far as it is possible to judge of a gun without a full trial, Mr. Dougall's invention appears to me to be a decided improvement, for the reasons which I shall presently state.

Fig. 38*.

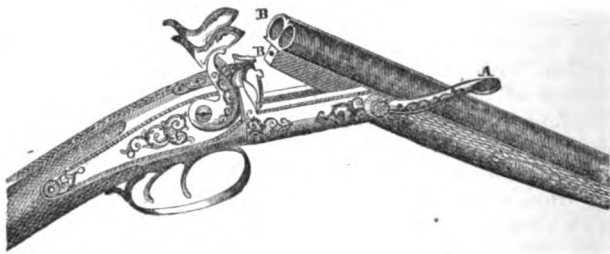

DOUGALL'S LOCKFAST BREECH-LOADER OPEN.

Mr. Dougall's lockfast breech-loader, which is the name by which he has distinguished it, may be described with the aid of the annexed engraving as follows:—A shows the lever turned so as to oppose the eccentric of its hinge bolt to the back of the bolt hole, and thus draw forward the open ends of the barrels, B, from the corresponding parts of the false breech, also marked with the same letter. By this action there is a space rather more than an eighth of an inch wide left between the two opposing surfaces, and the cores on the false breech as well as the pin below them are liberated from their corresponding sockets, so as to allow of the barrels being tilted in the usual way without any of that friction which so soon wears the metal of the breech and barrels away. This is more clearly

indicated in section in the plan beneath, in which the barrels are lettered F, the false breech E, the eccentric G, and the lever H. The wood of the stock is shown in section, also at I. The eccentric and lever moving it are shown together

*Fig. 38**.*

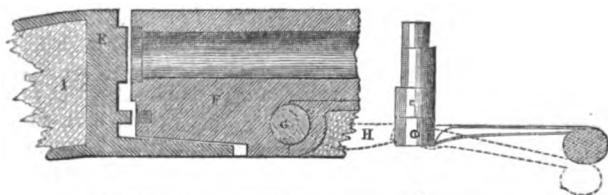

LONGITUDINAL SECTION OF DOUGALL'S GUN AND
PLAN OF ECCENTRIC BOLT.

in the third engraving, which will enable my readers to have an idea of the power by which the barrels are driven back and held firmly against the false breech, the projecting cores on which effectually block up their open ends, and prevent them also from tilting. The lever is jointed with sufficient liberty to move it out sideways from the barrels, and thus, though it lies smoothly and compactly close to the stock when not used, it can be freed from it when the fingers lay hold of it. By these several means the following advantages are obtained—1st. The cartridges are as easily introduced and removed as in the ordinary gun. 2nd. The pins are more firmly held than in the Lefauchaux action, by which escape of gas and any tendency to bend them are avoided. 3rd. As there is no friction between the opposing surfaces, they do not wear away and allow the escape of gas. 4th. When the eccentric bolt wears away in course of time, a new one may be inserted at the expense of a few shillings. 5th. The barrels are securely held down in their places and prevented from tilting by the cores on the face of the false breech, and also by the pin below them. 6th. The eccentric bolt may be made much lighter than the hook or wedge of the Lefauchaux action, especially in that form known as the double-grip. The gun is used with the common cartridge, either of French or English make, and the locks and

hammers are of the ordinary form. Of course the eccentric bolt and socket must be carefully case-hardened, without which their surfaces would soon wear away; and, indeed, even with the adoption of this precautionary measure, some gun-makers predict that they will become loose, but time, and time alone, can settle this question.

Mr. Daw, of Threadneedle-street, London, has lately introduced a breech-loading gun to this country, which has for some time been well known abroad, though in a less perfect state. It acts in my opinion as a needle-gun, but as he objects to its being called so, I place it among those with which he himself considers that it should be classed. Externally it looks like a percussion muzzle-loader, the hammers falling upon two projecting pins, which resemble ordinary nipples, and are pierced by what *Mr. Daw* calls *pistons*, but which any mechanic must know, are not at all allied to that well-known appliance. They are really strong short needles or pins, and act as such upon the caps in the base of the cartridge cases. Perforating the break-off, the point of each terminates in the middle of the open end of the barrel, much on the same principle as in Lancaster's gun, but obliquely, instead of in a straight line with its axis. The barrels are raised as in the Lefauchaux, but they are secured by means of a spring bolt running through the lower part of the break-off to a lump on their under side. A slide worked by means of an inclined plane, draws out the exploded cartridge case most simply and effectually. The cartridge case (patented by Schneider) is very ingeniously made, being of paper as usual, excepting the base, which is brass, and contains a hollow of the size of a copper cap, pierced at its apex internally by a hole, communicating with the powder. The caps inserted with a brass anvil inside it, grooved on its sides, and the blow of the pin explodes it by the counter pressure of the anvil. By this arrangement all the advantages of a central fire are obtained, without leakage by the side of the pin, and without spoiling the case. I have found experimentally that the gun acts well as far as security against misfires and accidental firing is concerned, but as to its powers of shooting I cannot speak, never having tried it against a target or in the field.

NEEDLE GUNS.

Several plans have been invented, in which a cartridge is exploded by means of a blow from a needle given to a cap in the line of the axis of the barrel, and not at right angles to it. The celebrated Prussian needle rifle is an example; but the arrangement is defective, from allowing a considerable escape of gas through the aperture for the needle into the works of the lock. In this country two plans on this principle have obtained considerable support—one patented by Mr. Needham, and the other by Mr. Lancaster. There is, however, a considerable difference in the two modes of carrying out the details, and each must be separately described.

MR. NEEDHAM'S NEEDLE GUN.

The advantages of this gun are stated to consist in the greater simplicity of the gun itself, in the more perfect closure of the breech, in the cheaper cartridge which is used with it, and in the absence of the necessity for loss of time in extracting the case, the residuum left after the discharge being pushed forward by the next cartridge as it is introduced. But in order to make a comparison in these respects between this and the Lefauchaux gun, it will be necessary to examine that of our English maker as carefully as we have investigated the construction of the French invention.



FIG. 39. NEEDHAM'S NEEDLE GUN, CLOSED.

In external appearance Mr. Needham's gun differs greatly from any of those which have already been described. Owing to the nature of the lock, there is no hammer rising up on each side, so that there is a nakedness to the eye long

accustomed to this prominent feature in the flint and percussion guns. There is also a necessity for an increase of total length to give room for the lock, which lies between what may be called the false breech and the barrels, and not outside both, as in the ordinary forms. This increase is, however, not to be reckoned at the total length of the lock, but only at about half of that measure—namely, two inches—the difference being accounted for by the fact, that the false breech is placed farther back than usual. There is also a projection on each side in front of the trigger-guard, which is the lever employed to open the breech. Above and behind this, on each side, is a recess in what appears to be the barrel, but which is only a continuance of that tube; and

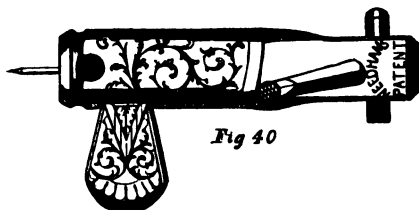
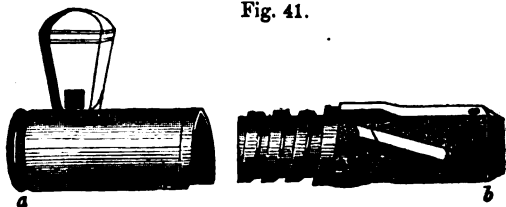

Fig 40

BREECH PLUG AND LOCK, SCREWED UP. (HALF SIZE.)

in this lies a strong cylinder of iron, which is at once the lock and the breech plug. (See fig. 40.) By turning upwards the lever this part is shortened, the object being accomplished by making it in two parts, and the front being screwed on to the back, it is so arranged that while the latter is fixed, the former is screwed backwards or forwards as the lever is turned up or down. (See fig. 41). When, there-

Fig. 41.



BREECH PLUG AND LOCK-CYLINDER. (HALF SIZE.)

fore, it is desired to open the breech end of the barrel, it is only necessary to shorten this plug, by turning up the lever and then drawing it away from the barrel. It stands out at a right angle, as represented in fig. 42, in which the under side of the barrels is shown, with one lock and plug turned out ready for loading, and the other in its place. On carefully examining these parts in the real gun, a needle is seen projecting through the plug, and this is the means by which the charge is exploded. The whole principle may therefore be now described as consisting of the formation of a chamber behind each barrel, of the same metal and continuous with it. In this is fixed, by means of a bolt at the back, and a strong cylinder, a plug so constructed as to be capable of being lengthened

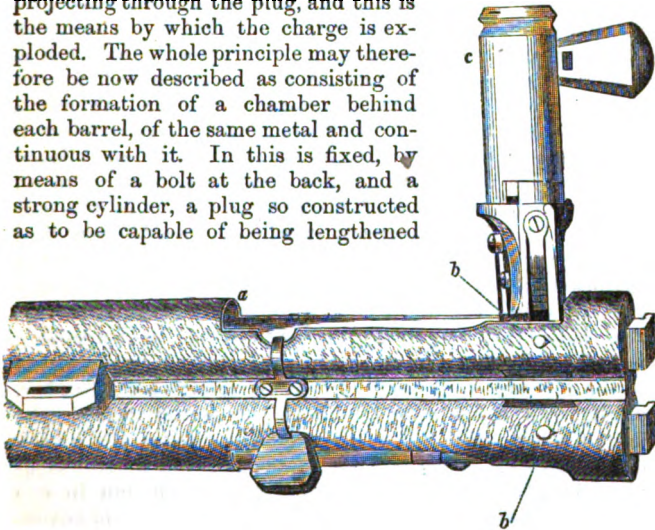

FIG. 42. UNDER SURFACE OF BARRELS. THE LEFT OPENED FOR INSERTION OF CARTRIDGE; THE RIGHT CLOSED. (HALF SIZE.)

and shortened, and containing a needle which is projected forward from the front of the plug into the breech end of the barrel, where the cartridge is placed, with an explosive cap in its base. The details of these various parts it will now be necessary to describe.

The barrels are forged in the same way as usual, but they must be selected of greater than the ordinary length by about four inches, and as this extent of the breech end is occupied by the chamber for the lock, the strength must be as great

at four inches from the breech end as in other guns at that part itself. This will be better understood by referring to fig. 42, which shows the chamber opened ready for the reception of the cartridge, and which will then give an idea of the part where the real barrel begins, which is marked *a* in the cut. There must be enough strength behind this to resist the backward action of the explosion, but the metal need not be left of full thickness for this purpose, as the area upon which the force is exerted is only that of the diameter of the bore. The strain is not entirely upon the bolt-hole *b*, which keeps the breech-plug up against the barrel, for the base of the lock-cylinder is wedged up, and transmits the recoil to the stock. There is nothing very peculiar in other respects in Mr. Needham's barrels, which are relieved before in the usual manner, and also opened behind to an extent which will allow of the ready insertion of the cartridge. By this arrangement it will at once be seen that when the breech-plug *c* is in its place, the chamber for the reception of the powder is similar to that of the French gun already described, and that there is no conical chamber like that in the breech of the percussion gun. In this respect, therefore, the two guns are alike; and if there is any virtue in the Manton, Wilkinson, or other form of breech chamber, neither can claim it, and both in this matter stand on the same footing. But when the mode of closing the breech comes to be examined, it will be seen that this is more complete in Mr. Needham's than in the French gun in one particular, while it is less so in another, the balance of advantage and disadvantage being somewhat difficult to strike.

The breech-plug (fig. 41 *a*) should be considered as quite independent of the lock, though it also contains that important part within it, and has a small hole in its face to allow of the needle being driven through it into the cartridge. In this hole is the element of weakness, for through it, however well the needle fits, will be a small escape of gas, consequent upon the explosion. Independently of this the plug consists of two parts, each of which serves a double office—firstly, of closing the breech, and secondly, of acting on or containing the lock. In reference to the breech, this plug may be described as consisting of two portions—an anterior (*a*, fig.

41), which is projected into the barrel, and a posterior part, which forces it forward as the screw is turned by the lever. The part *a* terminates in a short cone which fits accurately into the barrel, and with the aid of the wad at the base of the cartridge closely fills the aperture and prevents the escape of gas between the two circumferences. But the centre of this, where it is pierced by the needle, as shown in fig. 40, is not so completely free from escape, and to prevent the gas from passing backwards into the lock, a hole is drilled as there indicated. These two divisions are each tapped, the anterior one being constructed with a female screw, and the posterior showing a male screw of a strong formation (fig. 41 *b*). The effect of this is so obvious as scarcely to require the explanation that, when one is fixed as it is by the bolt (fig. 42 *b*), and the other is turned by the lever, the total length is increased or diminished as the case may be. The pitch of the screw is so slight that no force which can be applied by the explosion will drive the plug back; and its lever, when closed, being also held in its place by a spring catch (see fig. 42), a sufficient resistance is doubly secured.

The lock has been already described as being contained within the breech-plug, and therefore its actions must be of small size and of simple construction. Independently of the plug which contains them, it may be said to consist of four actions:—1st, the needle (fig. 43); 2nd, the mainspring (fig. 44); 3rdly, the screw cam (fig. 45), which drives the needle back; and 4thly, the scear (fig. 46 *a c*), which holds it ready for the trigger. There is also a bolt (fig. 47), which is intended to act as a substitute for the "half-cock" of the ordinary lock, and which

really is quite as efficient in preventing danger. The needle (fig. 43) consists of three parts—a centre and two extremities. The front is a mere needle *a*

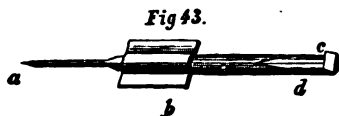

THE NEEDLE. (HALF SIZE.)

about a line in diameter, and terminating in a sharp cutting point, which readily pierces the paper base of the cartridge. The middle receives this needle, and consists of two flat shoulders or wings standing out from a strong pillar (see *b*),

and sliding in corresponding traverses, within the posterior half of the breech-plug. These wings answer a treble purpose—firstly, they receive the pressure of the spring from behind; secondly, they maintain a steady sliding action; and thirdly, they are capable of receiving the pressure of the cam (fig. 45), which is a double inclined plane fixed within the plug, and which, when turned round, thrusts the whole needle backwards. When this is done its posterior extremity being notched, drops upon the scear and is held back after the cam is restored to its original position. In addition to the notch for the scear (see fig. 43 c), there are sometimes two others at the side (at *d*) for the reception of the bolt, but in those lately made by Mr. Needham the stop is effected by the bolt dropping into the scear instead of the needle, as will be presently explained. The *mainspring*



Fig 44.
THE MAINSPRING.
(HALF SIZE.)



Fig 45.
THE SCREW CAM.
(HALF SIZE.)

(fig. 44) is of very simple form, being merely a spiral spring dropped into the posterior half of the plug and pressing against the wings of the needle. Next comes the *screw cam* (fig. 45), which is fixed within the plug, and is perforated by a hole for the needle; two inclined planes are so arranged that as the plug is turned round they press upon the wings in the needle already described, and push it back till it catches the scear. As a matter of course these cams are

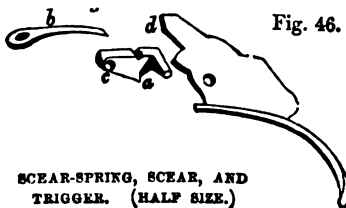

Fig. 46.
SCEAR-SPRING, SCEAR, AND
TRIGGER. (HALF SIZE.)

reversed on the two sides of the gun, since the lever in one case is turned to the right and in the other to the left. The *scear* and *spring*, with the *trigger* (fig. 46), complete the actions in this lock, with the exception of the

bolt. The scear *a* is much smaller than in the common lock, and is a catch of the most simple description pressed down into its place by the spring *b*, and working upon the centre *c*. As in the old lock it has a projecting arm which catches the trigger, but since it must be pushed down instead of up, the trigger requires to be of a somewhat different construction in order to accomplish the liberation of the needle. This is effected by carrying forward a lever in the trigger (see fig. 46, in which this is represented at *d*), ready to depress the arm of the scear below it when the trigger is pulled. From the want of room to play, and the consequent small size of scear, there is not the freedom of action to be found in the old locks, which will be missed by those who are fond of handling them and making them "speak." This, however, is a mere fancy; and so long as the lock does its duty with safety and efficiency, it is little consequence whether it is musical or not. Lastly, the *bolt* (fig. 47) is to be described as follows:—

It is made in the form of a short screw, terminating within in a sharp wedge, and without in a lever about an inch in length. The bolt is inserted in its place by screwing it in till it reaches its bearings; when home, a little projecting knob traverses a smooth surface, slightly rounded, on the outside of the lock, so that when the lever is either raised or depressed, it is held firmly in that position. On comparing the shape of the wedge at the end of the screw with the notches in the needle, when the old plan of stop is adopted, it will at once be seen that when the former is raised, this wedge lies in the axis of the needle, and allows the longitudinal notch to traverse freely upon it, while on depressing it after the needle is caught by the scear, this same wedge acts as a secure catch upon the third notch of the needle, and prevents its being liberated on the pulling of the trigger. When the scear is bolted instead of the needle, the catch merely drops into a notch in it, but in either case, when these parts are in good order, and the bolt is lowered so as to show the word BOLTED, as in fig. 39, the lock is as safe as need be, and I believe that there is far less danger than in the ordinary lock at half-cock, because there is no chance of Mr.



Fig 47

THE BOLT.
(HALF SIZE.)

Needham's bolt being raised in passing through a hedge, which may happen to the striker of any of the locks constructed on the ordinary pattern. After the above description, it will at once be apparent that in the act of opening the breech, the lock is cocked, and that before closing it, the bolt ought to be lowered so as to show the word **BOLTED**, or else the gun is in the same dangerous state as it would be if on full cock in the ordinary kinds of gun. This precaution is of great importance to the safety of the sportsman who uses Mr. Needham's invention, and as the bolt can be raised by the left hand at the moment of taking aim, there is never any necessity for carrying this gun cocked, or I should rather say unbolted.

The *cartridge-case* employed is a much cheaper and more simple affair than that used for the Lefauchaux gun, being

Fig 48.

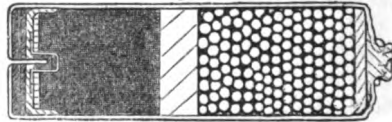

SECTION OF LOADED CARTRIDGE. (FULL SIZE.)

composed, however, of the same elementary parts, with the exception of the brass pin, whose office is here performed by the needle. Every part, however, is modified, and there is not nearly so much difficulty in constructing it. Besides this, the case is not withdrawn after being used, so that there is not the same necessity for its fitting the chamber easily, as in the French gun. The most important part is the arrangement of the wad and cap, which must be examined attentively, in order to comprehend their offices (see figs. 48 and 49), in which these parts are represented in

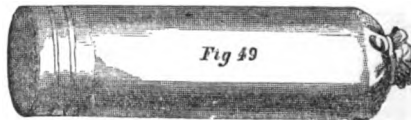

LOADED CARTRIDGE. (FULL SIZE.)

section as well as in perspective. Fig. 48 shows the strong wad with its metal-plate, which remain behind after the explosion, and are pushed forward in front of the next cartridge as it is introduced. These are perforated by a central hole for the ready passage of the needle, as also is the next for the insertion of the cap, which has four flanges to keep it from being thrust forward through the powder, by which it might be prevented from exploding. The metal-plate is for the purpose of preventing the cartridge from entering the barrel beyond its proper chamber. This plate is slightly wider than the chamber, and is stretched across its mouth till the cartridge is exploded, when it is flattened out and offers no resistance to the wad being pushed forward before the next cartridge. It also tends to prevent the escape of gas, and to a certain extent fulfils that office. The cap itself has its fulminating surface turned towards the needle, but the explosion, aided by the sharp point, breaks it up, and the powder is easily ignited. Upon this base the case is constructed of common cartridge-paper, and when the powder and shot are inserted at the open mouth, with only a wad intervening between them, the paper is tied as represented in fig. 49, which however is incorrect in giving a wad in front of the shot. These cartridges are sold at 30s. per 1000.

The advocates of Mr. Needham's invention (the sale of which in Ireland is committed to Mr. Rigby, who is occupied in certain improvements upon it) maintain that it is superior in the following particulars to the French breech-loading gun. They assert that it has all the advantages the latter claims over the muzzle-loader—that is to say, it is more rapidly loaded and more safe both in loading and in use; and in addition, it claims over and above these that the cartridges are half the price, that they are charged with less trouble—that there is no necessity for withdrawing the case after the discharge, the wad left behind being pushed forward by the next cartridge; and lastly, that while reloading one barrel, the other is ready for use. It is also stated that the gun stands wear and tear better than the French gun, but this I cannot see is likely to be the case, because there is the same wearing of the bolt, whether the lock and plug come away sideways, or the barrel is depressed at the muzzle

so as to raise the breech. By the addition of the perforated metal-plate and wad behind the cap the escape of gas so much complained of in all the old needle guns is very much obviated, but there is still some slight defect in this respect.

The opponents of this invention assert that in practice the needle is apt to break, that the lock soon corrodes from the escape of gas by the side of the needle into it, that the management requires too much care for ordinary sportsmen, who from being long accustomed to one form, are not easily induced to use another. Of its shooting as compared with other guns, I shall speak hereafter.

MR. LANCASTER'S NEEDLE GUN.

To obviate certain objections in the ordinary needle gun, as well as in the French gun of Lefauchaux, Mr. Lancaster has patented certain improvements, which have now been before the public for some years. They consist in the adoption of the French crutch, exactly in the form already described, but with a different mode of exploding the cartridge, and with the addition of a very ingenious piece of mechanism for bringing out the cartridge case after its explosion. The brass pin of the cartridge is done away with, and a fulminating powder, between two discs of copper, is exploded by a blow from a central needle, which however does not perforate them; and there is consequently no escape of gas. Moreover, the needle is not contained within the lock, but is driven forward by the blow of the hammer; so that, even if any corrosive gas escaped, it would not derange the mechanism—the needle alone suffering from it. As the barrels travel forward in the act of turning the lever, the false breech is enabled to be undercut, and thus, when closed, there can be no tilting whatever, as is alleged to take place in the French gun of the ordinary make. The cartridge in other respects does not differ from the French one, nor does the chamber in which it is placed; and there can be no difference in the shooting of this gun from that which has been described at p. 255. It remains to be seen whether the details connected with the cartridge are of sufficient im-

portance to justify the outlay of twenty guineas additional, which is about the difference between the price of Mr. Lancaster's guns and those of Lefauchaux's make, as constructed and sold by our best makers, with one or two exceptions, who are able to get high prices for anything they sell. The external appearance of this gun is shown in the following sketch :—



The barrels in no wise differ from the French form, except in the exterior of the breech-end, where they are necessarily slightly stouter, to allow of the cutting away of a small groove for the little catch which delivers the cartridge. This lies between the two barrels, and works backwards and forwards with an easy and smooth action, as will be presently explained. The hinge on which the barrels are lowered varies from that of the Lefauchaux gun in admitting of a sliding motion by means of a slot, instead of a mere eye, fitting closely upon the bolt. By this arrangement the barrels, as the lever is moved, are drawn away from the false breech, and the latter is enabled to be undercut, so as to secure the breech from being tilted up and opened during the explosion. In other respects there is no difference, as far as I know.

The delivery of the cartridge is effected by means of a sliding piece of metal, which is constructed of the following shape (fig. 51), in which *a a* represent two views of the

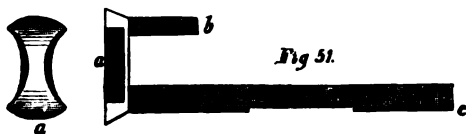

CARTRIDGE EXTRACTOR. (FULL SIZE.)

little wedge which lies between the barrels, and is so bevelled off on each side that it is accurately fitted to the copper base of the cartridge case, completing the circumference of the chamber in the breech intended to receive it, and fitted accurately to it. This wedge *aa* has two slides *bc* projecting

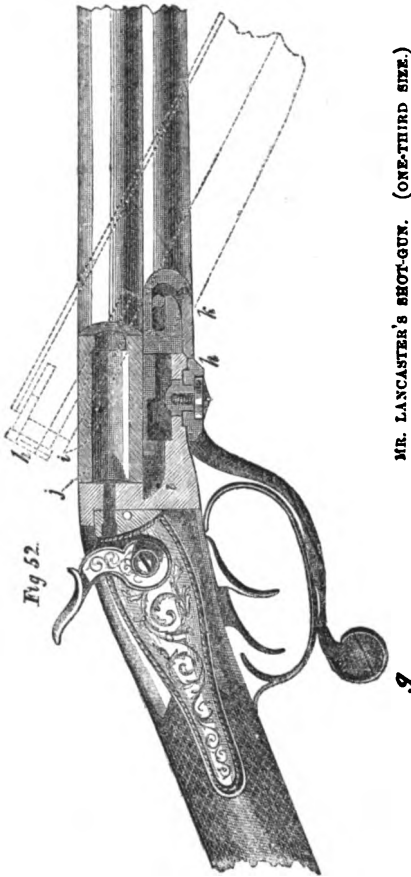

MR. LANCASTER'S SHOT-GUN. (ONE-THIRD SIZE.)

forwards, and lying in the angles formed between the two barrels above and below. The upper one *b* is a mere rod; but the lower *c* has a notch in it, which is acted on by the lever as it is turned, whether to open or shut the breech. The consequence is, that when the cartridge is inserted, it is carried into its place before the breech is lowered, and when this is reopened the wedge is thrust out, and acting on the copper lip of the cartridge, it brings it out of the chamber, when it lies quite uncon-

fined, and is easily removed by the fingers. This will be more readily understood after investigating the nature and shape of the lever and chamber.

The lever is similar in principle to that of the French gun, and exactly resembles in outward form one of its patterns (see fig. 34), but differs from the common one in passing backwards over the trigger-guard, instead of forwards. The working part is, however, much more complicated, inasmuch as it has three separate duties to perform. A reference to fig. 52 will show its appearance; but its internal construction is too intricate to be understood without an actual examination. The part marked *g* indicates the external extremity of the lever, and *h* the centre upon which it works; but above this, though the section is correct, it is hardly likely to teach the uninitiated the shape of the inclined planes which, firstly, move the barrel backwards and forwards; secondly, act on the cartridge extractor; and thirdly, close the breech by driving the bolt *i i* under the false breech. The construction of these parts is admirable, and great ingenuity is displayed in their design and execution; but to open and close Mr. Lancaster's gun is not quite so easy as the corresponding action in that of Lefauchaux. Still, a very little practice makes the sportsman perfect in its use; and with moderate care it is not at all likely to get out of order. The separation of the barrels from the stock is managed in the same way, but it also demands a little practice; and I have seen more than one person, accustomed to handle guns, quite unable to accomplish the task of putting together one of these guns after having taken them apart. The dotted lines show the position of the barrels when tilted prior to reloading. As the breech rises the extractor is protruded from the rear of the barrels by its frame coming in contact with a fixed projecting stud, when seizing the lip of the cartridges, it carries them partially out of the barrels, the fingers being employed to remove them entirely.

The chamber is shown in the above figure at *j*, and in no wise differs from the ordinary construction.

The false or stationary breech, together with the *needles*, come next under consideration, and must be taken together

in order to be understood. They are given in fig. 53, which is a front view of the face of the breech; *ll* are the sunken

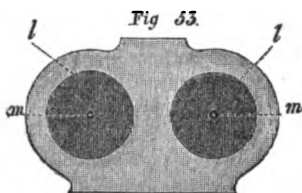

FACE OF FALSE BREECH. (HALF SIZE.)

Fig. 54



SIDE VIEW OF NEEDLE.
(FULL SIZE.)

parts for the reception of the rear of the cartridges; *m m* represent the points of the needles (shown separately in side view, at fig. 54), which work in holes formed in the centre of the sunken surfaces. These points are formed in a piece with the slides (fig. 54 *f*), which are free to move to and fro in recesses or slots formed for their reception. They are moved forward by the action of the hammers and explode the cartridges by means of the points which, upon the hammers being raised, are pushed back by the capsules of the freshly-inserted cartridges, ready to be again driven forward, as before explained. From this arrangement it will be apparent that there is no chance of breaking the needle, which projects so slightly from the face of the breech as to render such an accident impossible; while the escape of gas into the lock is out of the question; firstly, from the copper capsule being left intact after explosion—and secondly, from the fact that the needle is acted on by the hammer outside the lock (see fig. 50). The chief defect, in my opinion, is to be found in the chance of a misfire, which, from the capsule not being perforated by the blow of the needle, is greater than in the plan of Mr. Needham; but this accident, I am informed by those who have constantly used the cartridge, rarely happens. To show how cautious we ought to be in coming to conclusions in such matters, I may mention that in the gun trial of 1858, one of these cartridges loaded by the exhibitor missed fire, and I put it by for examination as to the cause. From inadvertency, however, I forgot all

about it for some months, but at length putting my hand upon it among other similar articles, I cut it open, and lo! *it was loaded with two charges of shot and not an atom of powder.* The needle and disc had done their duty well enough, as shown by the condition of the adjacent shot. Whether the carelessness was due to Colonel Ashley's or to Mr. Lancaster's man, I cannot pretend to say, but the missfire was certainly not owing to any defect in the cartridge itself.

The stock has no peculiarity whatever.

The lock resembles that of the back-acted detonator, or of the Lefauchaux gun, except in the shape of the hammer, which strikes the needle with its shoulder, and not (as in their case) with the head, which is therefore absent.

The cartridge case is the last part to be described, and as its plan is peculiar to Mr. Lancaster, it must receive full attention. It consists of a cylinder of strong paper of the same length as in the French gun, and with an extra thickness at the lower end, as is also seen in it. This extra part is turned in at the base (see fig. 56), and upon this lip is placed a stout disc of brass perforated with four holes (see fig. 55),

Fig. 55.

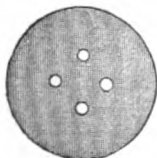
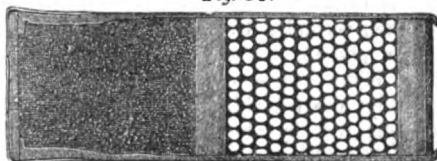

Fig. 56.



PERFORATED COPPER DISC. (FULL SIZE.) SECTION OF LOADED CARTRIDGE. (FULL SIZE.)

through which the flame passes to ignite the powder. On the other side, and in the space between these holes, is the fulminating powder; and then the whole is capped by a copper capsule, which is thin in the middle, where it receives the blow of the needle—but stout at the edge, where it is somewhat wider than the diameter of the cartridge elsewhere. The whole is put together in a workmanlike manner, and it is so strong as rarely to burst during the explosion. It is loaded in the usual way, and the lip turned over by a simple

machine sold by Mr. Lancaster; but care must be taken that the base of the cartridge is not placed upon a shot or other similar substance, for if this happened to be in the centre of the capsule while the wads were being pushed down on the powder or shot, or the lip turned over, an explosion might occur which would be by no means pleasant, if not dangerous. Fig. 56 is a section of the cartridge complete, as loaded ready for use; while a perspective view of the same is shown of full size in fig. 57.

Fig. 57.

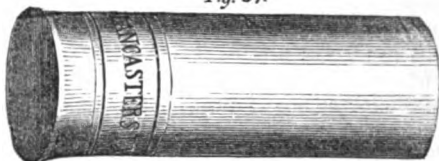

CARTRIDGE-CASE. (FULL SIZE.)

*Mr. Lancaster claims for his gun the following points of superiority over the ordinary breech loaders:—*Firstly, he asserts that the breech is made more secure by the undercutting; secondly, the cartridge is not so likely to explode in the pocket, because there is no projecting pin; thirdly, there is no escape of gas, the capsule not being pierced; fourthly, the cartridge never sticks in the chamber, being brought out by the little contrivance already described. Over the ordinary needle guns the advantage is said to be, that there is no corrosion of the lock by the usual escape of gas; and that the explosion is more effectively made.

*In opposition to these assumed advantages of Mr. Lancaster's invention over those of Lefauchaux, Bastin, and Needham, which may be considered its chief rivals, the only counterbalancing defects that, as far as I know, can be alleged, are: firstly, the greater prime cost of the gun itself; secondly, the constant large outlay for its cartridges, which moreover can only be obtained from the patentee; and thirdly, the complicated nature of the extractor. These *pros* and *cons* are, however, again carefully considered at some length in the following pages.*

THE CHATEAUVILLIER NEEDLE GUN.

A *needle gun* somewhat on the same plan as that of Mr. Lancaster has been invented for some years, and patented in the name of the Comte de Chateauvillier. I have been kindly favoured by its owner with the loan of one of these, made by Martigny of Brussels, and from it the following illustrations are drawn. It is necessarily a heavy gun, the specimen forwarded to me weighing above eight pounds; and from the quantity of strong iron-work which is introduced, in order to insure a safe closure of the breech, I do not see how this can be prevented to any great extent. But though the invention has this, in common with several other manifest disadvantages, yet I have thought it desirable to insert a description of it here, because, in my judgment, its principle undoubtedly contains the germ of several plans lately introduced to the notice of the public—namely, those of Bastin's shot-gun, already described, and of the rifles of Restell and Westley Richards, to be found in the next book, among the breech-loaders of the day. Thus, the lever is almost identical with that of Bastin's gun, which is, indeed, comprehended under the same patent, while the plugs closing the breech are very similar to those adopted in the two rifles alluded to above.

The *general appearance* of this modern invention is indicated by fig. 58, which shows the whole gun when ready for use.

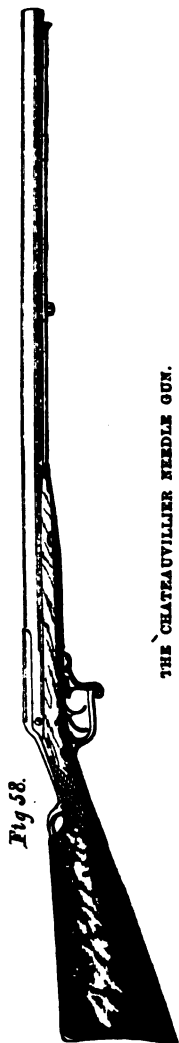

The following cuts show the principle of this gun. Fig. 59 is a half-size representation of the chambers *a a* opened to receive the cartridges, by raising the lever *b*. This acts on the plugs *c c* in the same way as in the Bastin gun, both being included in the same patent. In referring to the plans of the latter, which are given at pages 234-5 (figs. 37 and 38), it will be at once apparent that there is very little difference in the principle of these two levers. Both are compound, and act nearly in the same way; but in the one now under examination the lever itself is not fixed directly to the gun at all, but has one extremity free (see *b*), and the other attached to the two plugs *c c*, which slide backwards and forwards with it, the fulcrum being the two hinged props plainly shown in fig. 59. In raising the lever from its closed position, shown in fig. 58, the sliding plugs *c c* in some measure become a fulcrum by which the props before alluded to are lifted from their beds, and in closing the breech they are again used in the same way in depressing these props.

Such is the principle of the lever. It is now necessary to describe the nature of the plugs, and of the locks which strike the needles within them. They will be found described and illustrated on the opposite page.

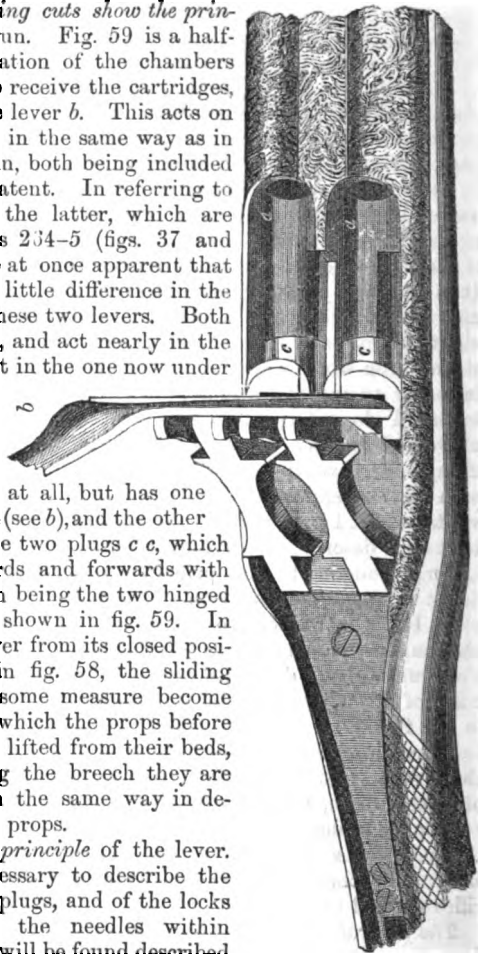

FIG. 59. THE CHATEAUVILLIER GUN, OPEN.

The *plug d* is shown in fig. 60, where *e* represents the point of the needle which strikes the cap on the cartridge. Beneath this is the lock, in which *f* represents one striker just discharged, the other being still cocked. The cock *g h* is drawn forward on the centre *g*, in order to half-cock or full-cock the gun, but unfortunately it is so arranged that the two locks are not independent, and both must be cocked together, though there are separate triggers. As, however, the loading is effected at the breech the danger is not so great as it would be in a muzzle-loader. Still the plan is very objectionable.

The cartridge used with this gun is similar to that of Mr. Needham, excepting that it contains a cap placed with the cup towards the powder.

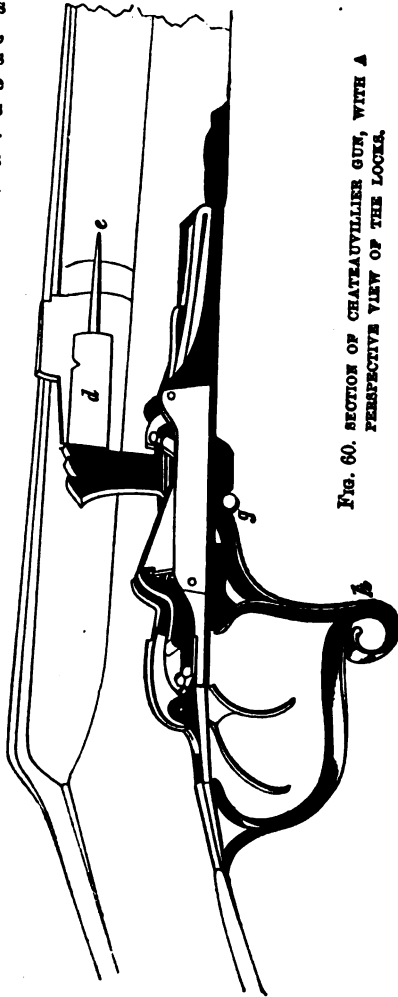

FIG. 60. SECTION OF CHATEAUVILLIER GUN, WITH A PERSPECTIVE VIEW OF THE LOCKS.

CHOICE OF BREECH-LOADERS.

Among the various kinds of breech-loading shot-guns which have been described, that of Lefauchaux is, in my opinion, on the whole, the best. Mr. Needham's gun has no doubt many advantages, but I see none sufficient to counterbalance the objection that it cannot be so readily cocked and uncocked as the French gun. It is quite true that when a person has become accustomed to its use, the bolt may readily be used, and for any one beginning to shoot, it will be just as easy to acquire its use as that of the ordinary hammer. But when a habit is acquired, it is not so easily broken through, and a sportsman who has long shot with the old percussion gun will much more readily take to that of Lefauchaux than to Mr. Needham's. This, however, is quite a matter for individual fancy, and in other respects I believe the two principles to be pretty equally balanced. Mr. Needham has the advantage in weight, his gun of No. 13 bore being only 6lbs. 10oz., while its rival is never less than 7lb. As now made, the joint or bolt of the French gun very rarely gives way with any ordinary amount of wear, and it is probable that it will last as long as the bolt of Mr. Needham's plug-lock. In the gun of the latter there is no cartridge to extract, and one barrel may be discharged when the other is opened without danger, which at times is a considerable advantage. If, therefore, the lock is kept oiled and thereby preserved from the effects of the gas escaping by the side of the needle, we see no reason why Mr. Needham's gun should be passed by. At the same time we repeat that it requires care in its use, and especially in the management of the lock. The needle also may be broken by gross carelessness, but without this it is safe enough. Bastin's patent, I am afraid, will be liable to get out of order from the slide becoming rusty. Otherwise it is a most ingenious invention. Mr. Lancaster's gun is exceedingly clever, and will no doubt be patronized by those who can afford to give long prices. The means for delivering the cartridge is one of the most beautiful contrivances I have ever seen, but to obtain this, there is a complicated slide connected with the bolt which is very apt to be deranged by a careless sportsman. In the

shooting of his gun there ought to be no difference from that of Lefauchaux, and it must stand or fall by the merits of its breech and cartridge. Those who use it must do so with the full knowledge that they cannot renew their stock of cartridges without resorting to Mr. Lancaster, whereas the French cases may now be obtained in all our principal towns. Lastly, the needle gun of Count Chateauvillier has several objections to which I have alluded, and which will always militate against its general adoption.

In addition to those guns which I have minutely described, there is one put forth by Messrs. Terry and Calisher, on the same principle as their rifle, to be hereafter described. The fact, however, that it requires the strong rifle percussion-cap to perforate its cartridge is quite sufficient to condemn it. Moreover, its performance at the target is very inferior, and I have not thought it worth any further notice.

THE LOADING OF CARTRIDGE-CASES.

The various cartridge-cases are loaded according to the particular plan adopted with each, and it is therefore necessary to allude to them *seriatim*, beginning with

The ordinary French cartridge for Lefauchaux's gun, which requires only the powder and shot to be put into it and wads exactly similar to those used with muzzle-loaders. These are rammed down precisely as described for the old-fashioned gun at page 244, but with a short tool of the same diameter as the case, made expressly for the purpose. When this is done, it is usual to turn over the case with a stamp, so as to prevent the wad from becoming loose in the pocket. Most people cut their cases to the length which will just hold the charge and allow for turning over, but my own decided opinion is that the proper mode is to have them cut so as to be of exactly the length of the chamber of the gun, within an eighth of an inch. That is to say, there should be a small interval between the edge of the case and the commencement of the shoulder of the chamber. Then use such a thickness of wad between the powder and shot as shall bring the latter up to the proper level, and all difficulty is avoided. When thus loaded, the turn-over tool, which in

its most simple form is merely a stamp with a circular groove in it, is placed upon the top of the case, and twisted two or three times backwards and forwards, which causes the edge of the case to be rounded off, and the wad securely fixed. Some people take the still further precaution of gumming the edge of the wad, but this is quite unnecessary if the case is properly turned over. Others again use a little lid of thin pasteboard, which is put into the end of the case, and by a slight tap pushed down over the wad, when the whole is complete without turning over. Messrs. Trulock and Harris, of Dublin, have invented a little machine which does away with all the objections that can be urged, for it confines the wad in its place, whatever may be the charge and length of case. All that is necessary is to have the cases cut to the proper length of the chamber, then load in the usual way, and inserting the cartridge into a circular slit (fig. 61 *a b*),

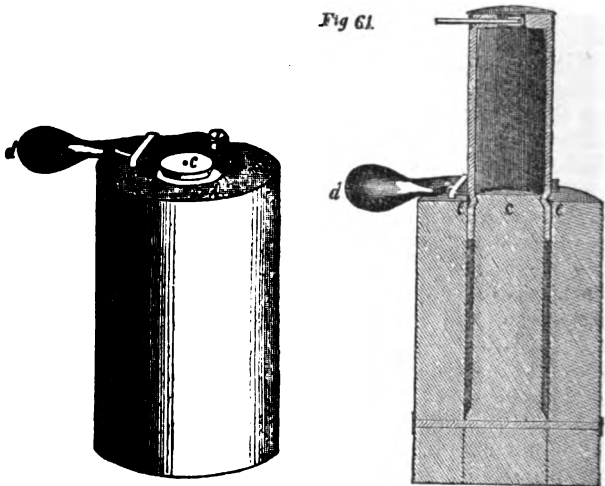

TRULOCK AND HARRIS'S CARTRIDGE-LOADING TOOL.

in which is a plug *c*, push it down till the wad touches the plug, when pressing the lever *d* against the cartridge, this

is turned round until a dent is made in it above the wad, as shown at *e e*. By this plan, the shot has no interval to pass over between the end of the case and the shoulder of the chamber, this space being filled up by the cartridge-case. Mr. Blanch, of Gracechurch-street, has also registered an ingenious little machine for turning over these cases, but I confess that I see no advantage in it over the hand-tool; and the choice, in my opinion, lies between the latter, that of Messrs. Trulock and Harris above described, and the well-known and efficient instrument invented by Mr. Jeffries, of

Fig. 61*.

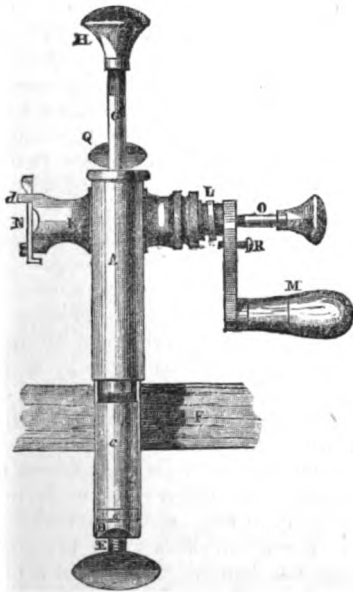
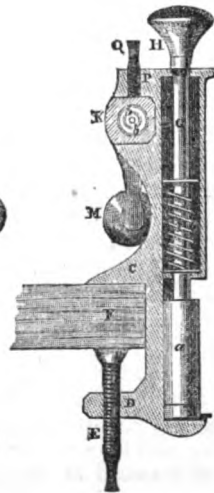

Fig. 61**.



JEFFRIES' CARTRIDGE FILLING MACHINE.

Norwich, which he has recently improved in portability, and reduced in weight with great advantage. The following is the description as furnished by Mr. Jeffries himself:

Fig. 61* represents a front elevation of the improved

apparatus; fig. 61** is a corresponding vertical section of the same, looking at right angles to the former, with the hammer depressed; and allowing the finishing box *M N O* to be detached. *A* represents the body or stem of the apparatus, which may be made of cast iron or other metal. The lower part of the stem is recessed or grooved semicircularly to receive the cartridge case, *a*, which rests upon the projection, *B*. Immediately behind this recessed or grooved portion of the stem are two lugs or shoulders, *C, D*, and through the lower one, *D*, is passed the pinching screw, *E*, which serves, in combination with the lugs, *C* and *D*, to secure the apparatus to the edge of a table or work bench, *F*, as shown in fig. 61**. The cartridge, which has been partially filled with powder and thick wadding, is placed in the recess or groove above referred to, and is then ready for ramming, which is effected by means of the hammer, *G*, being suddenly depressed by striking the nob or handle, *H*, with the palm of the hand. The rammer is elevated again by the helical spring *I*, contained within a hollow chamber cast in the stem as shown in fig. 61**. The semicircular groove or recess, referred to above, ensures the proper centering of the cartridge-case beneath the rammer head. After the wadding has been sufficiently rammed over the powder, the shot and thin wadding are introduced and passed through the same process of ramming, the cartridge is then placed in the finishing box, *M N O*, for the purpose of having the end of the case turned over inwards, so as to prevent the accidental displacement of the contents of the cartridge. This is effected by the screwed plug, *L*, the front or inner end of which is chambered out, and is provided with an annular groove or recess as shown at *b*, fig. 61**, into which the lip or edge of the cartridge-case enters, and by which it is turned inwards when the plug is forced forward by turning the handle, *M*, attached thereto. The cartridge is held in position during the finishing process above described by the cross-bar, *N*, hinged to the mouth of the box, and held by a hook or catch, *d*, fixed to the side of the mouth. When the cartridge is completed, the cross-bar is turned back so as to release the cartridge, and the latter is then expelled from the box by the plunger, *O*. The finishing box

is not cast in one piece with the stem of the apparatus, but is made removable therefrom, being held between a pair of lugs, P, by a set screw, Q.

Until within the last year or two many cartridges were spoiled by the first discharge, but if they are made very well, they serve again and even a third time, requiring only recapping. Several ingenious contrivances are sold with this object in view, and Messrs. Trulock and Harris have invented a very ingenious little machine for effecting this operation, an engraving of which is annexed, though the mode of using it will scarcely be understood without an inspection of the article itself. *The proportion of cases*

Fig. 61***.



TRULOCK AND HARRIS' RECAPPING MACHINE.

which may be used a second time is considerably more than one-half, when either those of Messrs. Eley's best make or Gevelot's (French) are used. To meet the wishes of their customers, and to avoid the chance of imperfect recapping, Messrs. Eley now engage to recap their own cartridges, at a small trifle per thousand over the price of the caps used in the operation, and I should always advise the adoption of this plan.

A small instrument called an extractor is sold for the purpose of removing those cartridges which do not readily come out of the chamber. It has a hole at one end for the pin, and a sharp hook at the other for the inside of the cartridge, if the pin should leave the case behind. No one should use a Lefauchaux or Bastin gun without this assistant about him. The plan of Mr. Elliot, of Birmingham, is an excellent one, his extractor being made to shut up like a buttonhook in a very useful and convenient form.

Mr. Needham's cartridge is described at page 278.

Bastin's cartridge is like that for the Lefauchaux gun.

Mr. Lancaster's is also to be managed in the same way, but he uses a block of wood in which a cylindrical chamber is cut to receive the cartridge while the turn-over tool is being used. This is done also in Blanch's, and one or two other

plans, and is intended to prevent the case from being spread too wide to fit the chamber of the gun. In loading Lancaster's cartridge, care should be taken that there is not a shot or a piece of any hard substance beneath the centre of the capsule, as if there happened to be such a thing, in ramming down or turning over it might cause an explosion, and seriously injure the hand. This caution has been previously given, but for fear of accidents, it is repeated here.

CLEANING.

The cleaning of all breech-loading shot guns is a very simple process, as they do not lead, nor do they become foul in a day's shooting to any extent. This exemption arises from the charge of powder being inserted at the breech, so that none adheres to the sides of the barrel as it does when poured down in the ordinary muzzle loader. In cleaning these guns, therefore, after the hardest day's shooting, all that is necessary is to open the breech, and then taking a rod, armed with tow, wipe them out till no black comes off on the tow, after which a very little oil protects the interior from rust. The locks and exterior should be treated the same as the ordinary gun. When the barrels will not admit a cleaning rod at the breech end, as in Needham's, Bastin's, and the Chateauvillier guns, they may readily be cleaned from the muzzle. In all these guns water is seldom or never required to be used.

In cleaning Mr. Needham's lock extra care is required in taking it to pieces for the purpose of oiling, for without some caution the needle may easily be projected into the eye of the cleaner, or that of some bystander. To avoid all risk of accident, the arm of the scear should be lifted by a turn-screw, so as to drive the needle out as in firing, and then the plug (fig. 41 a) being unscrewed, the needle, striker, and main-spring are left loose in their proper places, and may be taken out and oiled. To replace them, put them back as before, taking care that the notch in the striker (fig. 43 c) is turned so as to catch the scear; then pushing the needle against a piece of soft wood till the scear catches the notch, the lock is cocked and may be bolted, and the plug screwed on. This is the easiest way to a novice, but it incurs the risk of bending

or breaking the needle, all fear of which may be avoided by putting the parts loosely in their places, and then screwing on the plug (fig. 44) till it is home.

CARTRIDGE HOLDERS.

A very useful auxiliary to breech loading guns has recently been registered by Mr. Bussey, of Dunn's-passage, 485, New Oxford-street. It is in the form of an oblong case, made of patent leather, and holds from 20 to 30 cartridges, according to its size. A light leather belt is attached for the purpose of suspending it over the shoulder (fig. 62 *a*), and the car-

Fig. 62.

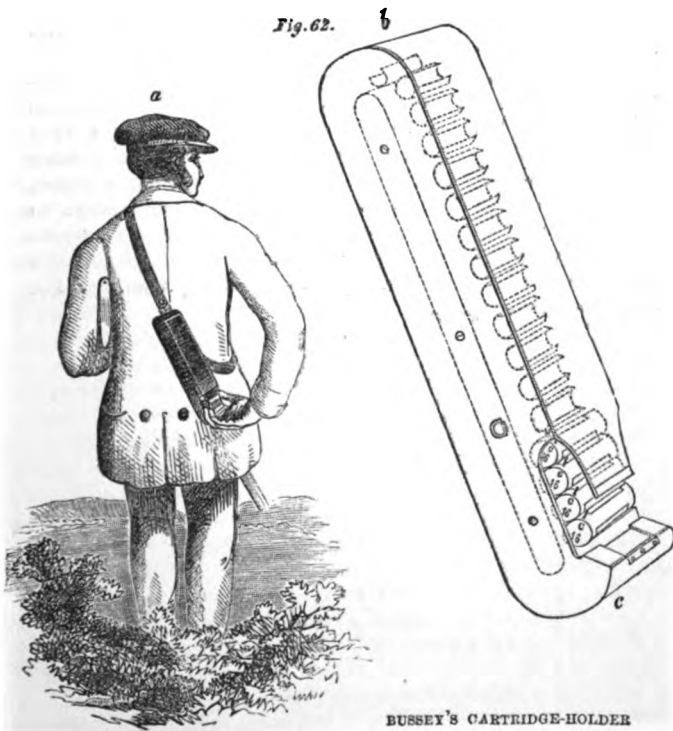

BUSSEY'S CARTRIDGE-HOLDER

tridges are easily withdrawn from an opening at one corner; the act of the removal of one bringing down another and leaving it in its turn in the same place.

The holder itself (fig. 62 *b c*) consists of a series of springs, each holding one cartridge, fixed on an endless band. This band revolves within a compact leather case, which is all closed up except a small aperture in the bottom end, at which each cartridge, when pulled out, is succeeded by another, the remainder being kept perfectly safe and dry without the trouble of any cover or fastening whatever. A belt, somewhat upon the same principle, is likewise made by the inventor, and is then buckled round the waist; but in it there is no endless strap, and the whole belt must be drawn round as the cartridges are extracted.

It is usual, however, among sportsmen, to carry their cartridges loose in their pockets, as they are not at all likely to receive such a blow as to ignite the cap, nor have I ever heard of such an accident occurring. Nevertheless, the above holder acts so well, and is so little likely to get out of order, that I cannot but think it will prove of great advantage to those who use the Lefauchaux, Bastin, or Lancaster breech-loader; but I am not sure whether the paper of Needham's cartridge cases is strong enough to resist the pressure of the spring without injury.

CHAPTER IV.

PUNT-GUNS.

COL. HAWKER'S PUNT-GUNS—BREECH-LOADING
PUNT-GUNS.

The shoulder duck gun is only a long single-barrelled gun of large bore, and, as far as I am aware, is always made in the form of a muzzle-loader, and usually with a pistol grip, as shown in fig. 63. According to Colonel Hawker, when intended to be used in the punt with a breech-rope or spring swivel, the length of barrel should be from 7 to 9 feet, bore from $1\frac{1}{4}$ to $1\frac{1}{2}$ inch, weight from 70 to 80lbs. The smaller the bore the longer the range, but the charge of shot is necessarily diminished. With the above weight the old flint lock must be used on account of the great recoil when the powder is fired so rapidly as is done by the detonator lock, and for which the weight of metal is not sufficient. If, therefore, any kind of percussion cap is employed, the weight must be increased from 30lbs. to 40lbs. For an ordinary shoulder duck gun, which is fully described at p. 87, in an extract from Colonel Hawker's book, the bore is usually about No. 6; length of barrels, 3, 6, to 4 feet; and weight, 12 to 20lbs. Double-barrelled guns of a peculiar principle are recommended by Colonel Hawker in his book, to which I must refer my readers for all particulars.

The loading of the ordinary shoulder duck gun is performed exactly as in all the muzzle-

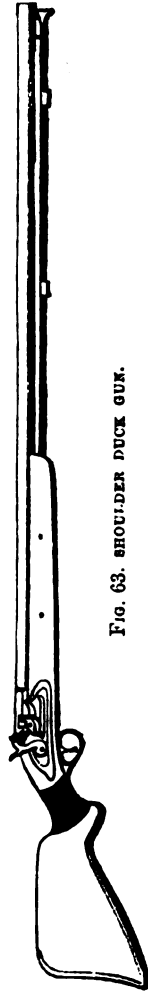

FIG. 63. SHOULDER DUCK GUN.

loading guns of smaller size; but punt-guns require a spoon to carry the powder and shot horizontally along the barrel. For punt-guns the following are the sizes of shot recommended by Colonel Hawker:—

For shoulder punt-guns . . .	}	No. 1 for fair shots.
		A for long shots.
For stancheon punt-guns . . .	}	No. 3 for starlight.
		No. 1 for fair shots.
Packed in cartridges		S.S.G., or L.G.
For geese		A., or A.A.
Ditto, if very tame.		S.S.G.

BREECH-LOADING PUNT-GUN.

Mr. Needham has sold several punt-guns on the same principle as his ordinary shot-gun, all the parts being made stronger and of larger size. These, I am told, answer remarkably well; and as the loading is very quick, and can be effected without raising the hand above the deck of the punt, the advantages are so manifest as to require no further allusion. *Mr. Needham* uses breech-ropes, which allow of the gun being kept lower on the punt than a spring swivel. Fig. 64 shows a sketch of the central part of one of these

Fig. 64.

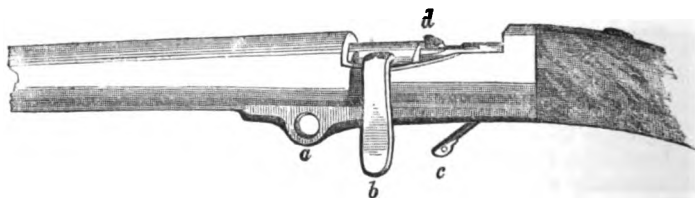

NEEDHAM'S BREECH-LOADING PUNT GUN.

guns, in which *d* represents the breech plug and lock, *a* the eye for the breech-ropes, and *c* the trigger, which is of course pulled by means of a small cord. The principle is so similar in all respects to that of his game-bird guns, that I must refer my readers to p. 267, where they are fully described.

The bore of the largest of his punt-guns is $1\frac{1}{2}$ in., weight 120 lbs., to carry 2 to $2\frac{1}{2}$ lbs. of shot. The smallest which he makes weighs 60 lbs., and carries from $\frac{3}{4}$ lb. to 1 lb. of shot. If these guns stand proof and shoot as well as they are said to do, they certainly constitute a great improvement in punt gunnery. Mr. Clayton, of Southampton, also makes a breech-loading punt-gun.

CHAPTER V.

ON THE CHOICE OF GUNS AND THE MODES OF TRYING THEM.

DESIDERATA IN THE SHOT-GUN—WEIGHT—LENGTH—PATTERN—PENETRATION—ABSENCE OF RECOIL—SAFETY—QUICKNESS OF LOADING—RESULT OF "FIELD" GUN TRIAL OF 1859—BREECH-LOADERS *versus* MUZZLE-LOADERS.

The desiderata in the shot-gun have been described at p. 175; and it now remains to compare the old muzzle-loader with more modern inventions, and to discuss the principles upon which the various patterns of guns can be severally selected for the special purposes to which they are applied.

WEIGHT.

As the weight of a double-barrelled shot-gun should never exceed $7\frac{1}{2}$ lbs., no invention, however clever, can be recommended which, with barrels of moderate gauge, is incapable of being made of that weight. Indeed, this limit may be assigned in all cases, and if, on putting a gun in the scales, it is found to weigh down $7\frac{1}{2}$ lbs., it should be rejected. The sportsman may be able to shoot with a heavier gun when not tired by carrying it; but let him walk for two or three hours with 8 or 9 lbs. on his arm, and he will find that his shooting is greatly injured thereby, and that a gun of inferior performance at the target will do more execution in the field, and should therefore be preferred without doubt. So also there is a limit in point of diminution of weight on the score of safety, which I have specified at p. 243, as far as

muzzle-loaders are concerned; but breech-loaders cannot be reduced so low by at least 8oz.

LENGTH OF BARRELS.

In length of barrel there is no difference between the various kinds of guns, excepting where there is a chamber that is opened to receive a cartridge, which is then pushed forward into the breech, as in Needham's and the Chateau-villier gun. These two are, therefore, of necessity somewhat longer than the old percussion or the crutch guns; but, as in Mr. Needham's gun the lock is also contained in this chamber, the whole length of it is not to be added, but only about one half, or two inches on the average—that is to say, one of his guns, with barrels 28in. long, will be in its whole length, (if adapted to the same person's shooting,) two inches longer than it would be of either of the other kinds.

PATTERN.

All guns should be so bored that they will deliver their shot in such a pattern that at forty yards a partridge or grouse has little chance of escape, if properly covered. It has been shown at p. 243, that to do this there ought to be in a thirty-inch circle from 150 to 160 pellets of No. 6 shot, and in this respect all the varieties are capable of being made nearly equally good.

PENETRATION.

By referring to the table at pp. 304–5, it appears that the ordinary percussion guns have a trifling advantage in strength of shooting.

ABSENCE OF RECOIL.

In this respect I believe that there is very little advantage to be found in any particular kind of gun, though among individual specimens of the various kinds, the recoil differs considerably

SAFETY.

The safety from accidents depends partly upon the absence of danger from bursting, and partly from freedom from risk in loading. In the former department it is clear that no gun is so safe as the ordinary percussion gun, which has a breech screwed solidly into it. Next to this, I should say, comes the Lefauchaux (and Mr. Lancaster's, which is similar in principle). Mr. Needham's is perhaps almost equally safe from this species of risk, but it has not been tried to the same extent. In reference to danger from explosion during loading, there can be no question that the muzzle-loader is beaten by the breech-loader; and that among the varieties of the latter, the Lefauchaux gun is pre-eminent. In fact, with ordinary care, it is almost impossible to do mischief in loading. A serious accident occurred to Lord Nelson during the loading of one of Mr. Needham's guns. It happened that the cartridge had missed fire from having been pushed too forward, and his lordship, while the needle was protruding into the barrel, drove the cartridge with a ramrod back upon it, causing the cap to explode; and the result was a serious injury to his hand. If, however, the plug had been previously turned out, as it ought to have been, no such accident could have occurred.

RESULT OF "FIELD" GUN TRIAL OF 1859.

In order to show the difference of performance in the several departments to which I have alluded, the results of the trial of various guns at Hornsey Wood House are appended in a tabular form on the next two pages. In the preface to this volume I have alluded to the circumstances which led to these trials of 1858 and 1859, so that it will be unnecessary to repeat them here.

TABLE OF THE PERFORMANCES OF THE

Targets made of double bag-cap paper, 90 lb. to the ream—all circular against a smooth surface of deal boards. This centre composed of which were cut evenly at the edges, weighing 18 oz. and 9 oz. re-occur in brown paper. Powder, Lawrence's No. 2, which was selected ounce); charges *weighed* in every instance.

Name of Maker,	Kind of Gun,	Bore.	Length of barrel.	Weight of gun.	Charge of powder.	Charge of shot.
			in.	lb. oz.	drs.	oz.
Pape, Newcastle	Muzzle-loader	12	30	6 11	2 ² / ₂	1 ¹ / ₂
Prince and Green, London	Muzzle-loader	12	30	7 6	2 ² / ₂	1 ¹ / ₂
Pape	Muzzle-loader	12	29 ¹ / ₂	6 8	2 ² / ₂	1 ¹ / ₂
Egan, Bradford	Breech-loader*	12	30	7 8 3	2 ² / ₂	1 ¹ / ₂
Prince and Green	Breech-loader	12	30	7 2 3	2 ² / ₂	1 ¹ / ₂
Pape	Breech-loader	12	30	7 0 3	2 ² / ₂	1 ¹ / ₂
Pape	Muzzle-loader	13	30	7 0	2 ² / ₂	1 ¹ / ₂
Needham, London	Breech-loader†	13	29	6 10 3	2 ² / ₂	1 ¹ / ₂
Egan	Muzzle-loader	13	28	6 14	2 ² / ₂	1 ¹ / ₂
Culling, Downham Market	Muzzle-loader	12	29 ¹ / ₂	6 10	2 ² / ₂	1 ¹ / ₂
Reilly, London	Breech-loader	16	30	7 4 3	2 ² / ₂	1 ¹ / ₂
Elliott, Birmingham	Breech-loader	16	28	7 4	2 ² / ₂	1
Needham	Breech-loader	13	28 ¹ / ₂	7 4 3	2 ² / ₂	1 ¹ / ₂
Hast, Colchester	Breech-loader	12	31	7 8 3	2 ² / ₂	1 ¹ / ₂
Reilly	Breech-loader	12	30	7 4 3	2 ² / ₂	1 ¹ / ₂
Elliott	Breech-loader	13	28	5 4 3	2 ² / ₂	1
Francotte, Liege	Breech-loader‡	14	29 ¹ / ₂	7 8 3	2 ² / ₂	1 ¹ / ₂
Averages
O. Smith, Derby	Muzzle-loader	15	30	6 14	2 ² / ₂	1 ¹ / ₂
Culling	Muzzle-loader	14	28 ¹ / ₂	6 11	2 ² / ₂	1 ¹ / ₂
Dougall, Glasgow	Muzzle-loader	14	27	5 14	2 ² / ₂	1
Joe Manton, London§ ...	Muzzle-loader	16	31	6 12	2 ² / ₂	1
Culling	Muzzle-loader	14	29	6 0	2 ² / ₂	1 ¹ / ₂
Reilly	Breech-loader*	15	30	6 14 3	2 ² / ₂	1 ¹ / ₂
Lang, London	Breech-loader*	15	29	6 8 3	2 ² / ₂	1 ¹ / ₂
Reilly	Muzzle-loader	14	29	6 4	2 ² / ₂	1 ¹ / ₂
Prince and Green	Breech-loader*	15	30	7 0 3	2 ² / ₂	1
Prince and Green	Muzzle-loader	14	30	7 0	2 ² / ₂	1
Hast	Muzzle-loader	15	30 ¹ / ₂	6 8	2 ² / ₂	1 ¹ / ₂
Reilly	Breech-loader*	15	28	6 4	2 ² / ₂	1 ¹ / ₂
Averages

* Lefauchaux's.

† Needham's.

‡ Bastin's.

SHOT-GUNS IN "THE FIELD" GUN TRIAL, 1859.

30 inches in diameter, with a centre 12 inches square, and nailed, forty thicknesses for the 40 yards, and twenty at 60 yards, the squares respectively on the average, with a slight variation, which will always because it gave satisfaction last year; shot, No. 6 (290 pellets per

No. of marks on face of Targets.		No. of Sheets pierced.		No. of shots through 20 sheets.		Total on face of 4 Targets.	Total through 4 Targets.	Gross Total.	Recoil of each Barrel in pounds.	Variation from average recoil for 2 Barrels.	Final Results.		
at 40 yds.	at 60 yds.	at 40 yds.	60 yds.										
158	118	63	60	28	33	5	2	399	69	467	69-63	3 under	470
148	93	53	65	28	22	1	2	363	53	416	66-65	2 under	418
116	129	46	40	25	28	1	1	331	55	396	68-64	1 under	387
144	80	32	58	28	30	0	2	324	60	384	untested	384
103	93	60	62	24	31	2	4	318	61	379	untested	379
132	93	65	38	26	33	2	3	318	64	382	70-68	5 over	377
117	71	47	61	29	37	4	8	296	78	374	untested	374
65	135	24	54	29	39	0	1	278	69	347	64-62	7 under	354
113	113	24	46	23	34	0	1	298	58	354	68-68	3 over	351
106	103	35	31	22	32	0	0	275	54	329	59-61	13 under	342
95	105	50	31	20	27	2	0	281	49	330	untested	330
73	99	22	42	30	40	0	1	236	71	307	64-66	3 under	310
97	95	31	20	23	26	0	0	243	48	291	65-61	7 under	298
100	77	32	28	33	25	0	0	237	58	295	72-69	8 over	287
88	91	37	31	23	27	2	1	247	53	290	76-73	16 over	263
90	87	20	28	20	31	1	0	225	52	277	64-68	1 under	278
60	49	31	40	25	23	0	0	179	48	227	74-68	9 over	218
106	97	33	43	26	30	1	1½	285	59	344	67-66	344
101	121	48	55	38	22	3	5	325	68	393	63-58	8 under	401
147	85	42	48	24	19	0	0	322	43	365	53-54	22 under	387
130	92	30	60	25	27	2	0	312	54	366	65-63	1 under	367
122	86	36	57	27	28	2	0	301	57	358	64-62	3 under	361
101	103	30	55	21	25	0	1	289	47	336	80-44	25 under	361
105	106	63	26	29	33	6	1	300	69	369	69-76	16 over	353
129	57	45	52	20	28	0	3	283	51	334	64-60	5 under	339
99	99	34	42	32	27	0	8	274	67	341	68-74	13 over	328
77	100	41	31	33	26	5	0	249	64	313	71-73	15 over	299
71	92	52	27	20	29	0	0	242	49	291	69-64	4 over	287
83	55	44	24	28	29	5	0	206	62	268	69-67	6 over	262
83	101	34	7	18	28	0	0	225	46	271	68-72	11 over	260
104	92	42	40	26	27	2	1½	277	56	334	65-64	334

§ Breeches by Trulock and Harris, of Dublin.

The following report of their performances is also extracted from the Field of July 9th, 1859, having been drawn up by myself. I have omitted such parts as have no permanent interest.

RECOIL.—It may be remembered that last year we attempted to measure the recoil of the guns by a machine designed by ourselves, but the spring (Salter's improved balance) only registering 60lb., it was not strong enough for the purpose, and we were obliged to abandon this test. On the present occasion, however, we were enabled to apply it to all but four of the shot-guns, and with complete success, its simplicity and accuracy being much approved of by (we believe) all those who witnessed its operation. By examining the table given below, it will be seen that the average recoil of the guns of a 12 and 13-bore was $66\frac{1}{2}$ lb., and of 14, 15, and 16-bore, $64\frac{1}{2}$ lb., the highest recoil in Class 1 being 76lb., and the lowest 59lb. In Class 2 the highest was also 76lb., and the lowest 44lb. These results are of great interest, and establish the fact which we always contended for, that the recoil is not in exact proportion to the shooting force of each gun, for taking the gun which heads the first class, the two barrels penetrated through 28 and 33 sheets respectively at 40 yards, yet the recoil was less than that of the next, by Mr. Prince, which pierced 28 and 22 sheets, and still less than the third in that class, which penetrated 25 and 28. The same holds good throughout the series, and we think it may be alleged that, granting the truth of the test, the proportion of recoil to shooting power varies considerably, and that the greatest kicker is not necessarily the strongest shooting gun. Another interesting point here established is, that the Joe Manton gun sent by Colonel Whyte is by no means remarkable for its amount of recoil, the average of its two barrels being 3lb. under that of the average of all the guns tested in its class; and lastly, the breech-loaders are shown to be quite equal in recoil to the average of the muzzle-loaders.

THE PATTERNS made by the several guns exhibited were, on the whole, extremely good, and in some cases extraordinarily so. By comparing the two classes, it appears that the average number of shots put into the 30-inch circle at 40

yards varies very little in the two classes, the first being respectively 106 and 97 for the two barrels, and the second class showing 104 and 92. Mr. Pape's and Mr. Prince's left barrels (in the first of each of their guns) put in the extraordinary number of 158 and 148 shots, or about 50 and 40 per cent. above the average. In the second class, Mr. Ollard's gun (made by Culling, of Downham Market) put in with the left barrel 147 shot, which is a tremendous pattern for a 14-gauge. His right barrel, however, showed only 85, so that the average of the two was only nine above that of Mr. Smith's gun, which gained more than this difference at 60 yards in pattern and penetration combined. Mr. Culling, the maker, who shot this gun himself, used only $2\frac{1}{4}$ drachms of powder, which will account for the good pattern at 40 yards and the comparative failure in other respects, but more especially for the very slight recoil which this in common with all his guns exhibited. At 60 yards the shooting has been extremely good this year, the pattern being excellent, and the average as compared with last year being decidedly better.

PENETRATION we hold to be the quality in the shot-guns only second to pattern, and we have been at great pains and expense to ascertain the precise power of each. To effect this, each barrel was shot twice at brown-paper targets twelve inches square, those at 40 yards being composed of 40 thicknesses, and those used at 60 yards of half that number. We employed nearly the same test last year, but the surface was more than twice as great, measuring in fact 28 inches by 11. It may be remembered that ten guns then pierced the 40 sheets; but though the paper was somewhat stouter, the shot being No. 5 instead of No. 6, as used this year, the task was not so difficult. On that occasion, as so many shots pierced the whole of the layers, we departed from the usual custom, and registered the number of shots, as we have done on this occasion, at 60 yards, but as this year at 40 yards only one gun performed the task, we counted the number of sheets, exactly as is done by Mr. Purdey and most of the best makers. The successful gun in this respect was a *breech-loader* of a 16-bore (though from its weight shot in Class 1) made by Elliott, of Birmingham; so that it appears that there is no in-

superable difficulty in obtaining driving power in this class of guns. Mr. Needham's breech-loader also nearly approached to it, having driven through 39 sheets with one barrel. Taking, however, the four shots (two at 40 yards and two at 60), Mr. Pape's muzzle-loader (No. 15) made the highest score, being in all 78 through the four targets, while Mr. Elliott scored 71, and Mr. Needham 69 in the same way. The increase in the driving power of the breech-loaders is, however, very considerable as compared with last year; and there now appears to be little or no difference between the two classes of guns in this important quality.

Having thus gone through the several results, it is now necessary to allude to the comparative merits of the various guns tried on this occasion. The great contest has been as between muzzle-loaders and breech-loaders, and it will be seen that in each class the old-fashioned gun has carried the day, though very closely pressed by its rival. Indeed, so near is the performance of the two, that we cannot think for a moment that for general purposes there can be a doubt of the superiority of the breech-loader, when quickness of loading, safety, and cleanliness are taken into consideration. The present trial has, however, disposed of the claims of the breech-loader to freedom from recoil, credit for which it is shown not to deserve in the slightest degree. That, *with equal charges of powder*, it does not kick so much as the muzzle-loader, is tolerably clear; but with the additional quarter of a drachm which it requires, it recoils quite as much. The highly creditable performance of Colonel Whyte's Joe Manton is also another feature worthy of being recorded, for though the gun is placed fourth in its class, it is considerably above the average in all points but penetration at 60 yards. We have submitted the barrels to several gun-makers familiar with "Joe Mantons," and they all are of opinion that those sent by Colonel Whyte are his make, while as to their state of preservation there can be no mistake that it is most extraordinary. At present they indicate a recoil below the average, but the new breeches put in by Messrs. Trulock and Harris, of Dublin, may possibly account for this. (See Colonel Whyte's letter in the *Field* of June 11th.)

The position in the table of each gun indicates the nature of its performances in the three qualities of pattern, penetration, and recoil. It is easy, therefore, without any further explanation, to see at a glance how each gun stands. It is necessary, however, to explain that where the amount of recoil is above the average, the number of pounds which is shown in the proper column is deducted from the total of shots, while on the contrary, where its recoil is below the average, a corresponding addition is made.

BREECH-LOADERS v. MUZZLE-LOADERS.

Having examined into the relative merits of the two kinds of guns, it may be well to sum up their advantages and disadvantages in a tabular form.

MUZZLE-LOADERS.

BREECH-LOADERS.

PATTERN.

Little difference between the two kinds.

PENETRATION.

Slightly superior.

Nearly equal, but not quite; requiring at least a quarter of a drachm extra charge of powder.

ABSENCE FROM RECOIL.

Little difference between them with the proper charge to make the performance equal.

With equal charges recoil less than the muzzle-loader, but with the allowance of extra powder which is required by the breech-loader the recoil is about equal.

HANDINESS IN THE FIELD.

The muzzle-loader can be made lighter than any other gun of equal bore and length of barrel.

Breech-loaders are all somewhat heavier than muzzle-loaders of the same bore and length of barrel. Mr. Needham's is the lightest of the breech-loaders, but requires an extra length to allow for loading.

SAFETY FROM BURSTING.

The muzzle loader is the safest in this respect.

Inferior to the muzzle-loader.

SAFETY FROM RISK IN LOADING.

By far the most dangerous; accidents occurring from a variety of causes, such as a piece of tow remaining behind to smoulder after the first discharge; or one barrel going off while loading the other, from the jar in ramming down.

Perfect safety during loading, especially in the Lefauchaux gun.

ABSENCE FROM FOULING OR LEADING.

This gun is peculiarly liable to become foul after twenty to thirty discharges, or, indeed, before that time, and also to lead.

All the breech-loaders are free from fouling and leading, and can be readily cleaned.

BOOK V.

THE SPORTING RIFLE.

CHAPTER I.

THE THEORY OF RIFLE SHOOTING, AND THE MODE
OF RIFLING THE BARREL.

DEFINITION OF THE RIFLE—VELOCITY DIMINISHED BY RIFLING A SMOOTH BORE—GREATEST AT THE MOMENT WHEN THE BALL LEAVES THE MUZZLE—VARIETIES IN THE FORM OF THE GROOVES ALMOST INFINITE—THE BARREL—METHOD OF RIFLING—TECHNICAL TERMS.

A rifle may be defined to be a species of gun which causes its projectile to rotate around the line of its flight. This is effected by means of spiral grooves or channels, which are cut on its internal surface, sometimes so slightly as to be invisible to the eye, but generally with a sharp margin. The consequence of this form is, as described by Robins, "that when the piece is fired, the indented zone of the bullet follows the sweep of the rifles; and thereby, besides its progressive motion, acquires a circular motion round the axis of the piece, which circular motion will be continued to the bullet after its separation from the piece; by which means a bullet discharged from a rifled barrel is constantly made to whirl round an axis which is coincident with the line of its flight. And hence it follows, that the resistance of the foremost end of the bullet is equally distributed round the pole of its circular motion, and acts with an equal effect on every side of the line of direction, so that this resistance can produce no deviation from that line. And (which is still of more importance) if, by the casual irregularity of the foremost

surface of the bullet, or by any other accident, the resistance should be stronger on one side of the pole of circular motion than on the other; yet, as the place where this greater resistance acts must perpetually shift its position round the line in which the bullet flies, the deflection which this inequality would occasion, if it acted constantly with the same given tendency, is now continually rectified by the various and contrary tendencies of that disturbing force during the course of one revolution."—*Tracts*, p. 330.

VELOCITY DIMINISHED BY RIFLING A SMOOTH BORE.

Such is now the admitted object of the grooves in the rifle, and it is unnecessary to support the view taken by Robius and others since his time, by the analogy of the top or the arrow. Whether the latter rotates or not in its flight is perfectly immaterial, for if it does, the motion is communicated by the air through which it passes, and not by the bow or the hand before it quits them. A ball from a smooth bore (that is, from a barrel not rifled in any way) will have a greater velocity and range than a similar ball projected from a rifled barrel, on account of the friction caused by the rifling absorbing some portion of the original force of the explosion. Hence, neither increased range, nor its synonym, velocity, is gained by rifling, but only truth or correctness of flight; so that, though the ball does not really go further, it will be of service at a greater range, because it will hit the object at which it is aimed. At the same time, the introduction of rifling may be said to increase our range—not, it is true, in the use of spherical balls, the flight of which it retards—but because from the spinning motion given to it, a more elongated ball may be used than from a smooth bore; and hence the weight being increased in a greater proportion than the area to which the atmosphere offers resistance in its passage, the flight is greatly extended. In a smooth bore a slightly oval ball can be relied on, if one end is somewhat thicker than the other (or egg-shaped), for that end being heavier will always fly forward; but a pointed cylinder soon "upsets," as it is termed, and is then at once rendered useless as a projectile. By upsetting is to be understood the turning

sideways of an elongated ball, and it is this accident which forms the chief impediment to rifle shooting. The impetus being given to the hind end of the ball, while the resistance of the air is offered on the front, there is a constant tendency to the one overtaking the other, in doing which the ball must necessarily offer its side to the point at which it is aimed. The greater the spin the more this tendency is checked, for no sooner does the base begin to turn over to the right, than it is forced round to the left, and so on in succession to every point in the circle of which its line of flight is the centre.

VELOCITY GREATEST AT THE MOMENT OF LEAVING
THE MUZZLE.

*It has been found by experiment that a ball will pierce certain substances at 100 or 200 yards, which it would fail to do at half or a quarter the distance; and upon this fact a theory has been propounded which is adverse to a fundamental law of nature. This theory is, that when the resistance offered by the friction against the sides of the barrel is taken away, the impetus given by the explosion is allowed its full scope, and the ball increases in velocity up to a given point. In fact, it is said that the ball *viris acquirit eundo*; but Mr. Boucher, in a letter to *The Field*, completely disposes of this fallacious theory by the following experiment, which I insert as detailed by him.*

“Again: with regard to the *penetration* of shot being, at all ranges, a test of its velocity, the correct interpretation of the law of action and reaction seems, in this case also, to be sadly overlooked and disregarded. I send you six bullets, taken from hundreds of a similar description. See fig. 65. Those marked *a* and *d* were fired at 40 yards’ distance, and penetrated about one foot; *b* and *e* were fired at 100 yards, and penetrated about two feet; while *c* and *f* were fired at 200 yards, and penetrated nearly three feet and a half. Now, sir, I have been coolly told in the columns of your paper (March 20) that ‘I am neither a profound thinker nor a careful experimentalist, or I must know the incontrovertible fact that a bullet *does gain in speed* after leaving the muzzle of the

piece,' and that this fact accounts for the greater force at the longer ranges, 'up even to a range of 250 yards, as some have

Fig. 66

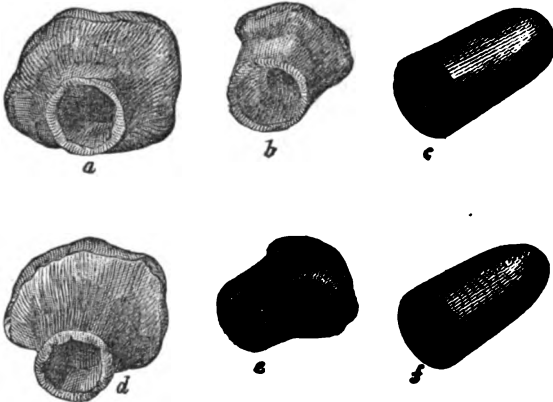

RESULTS OF SHOOTING AT VARIOUS DISTANCES.

surmised.' Yes, I have been coolly told that an absurdity, which is contrary to all the laws of motion, is an *incontrovertible* fact, because, forsooth, some have *surmised* it. But, sir, I appeal to you if such a monstrous theory can possibly be true. Look at *a* and *d*, which penetrated the shortest distance; they are flattened out, and turned over almost like a mushroom. Is there any indication of *want* of velocity in them? No: on the contrary, the velocity or action must have been immense, and the reaction of the sand sudden and equal, or the bullet could not have possibly been so wonderfully altered during the short time which it took to penetrate only one foot. Look at *b* and *e*, they show that they were actuated by less velocity, and, consequently, were less altered in shape by the reaction, and therefore penetrated somewhat further. But look, again, at *c* and *f*; they penetrated to the greatest depth, but where are the signs of great velocity in them? Their appearance is nearly as perfect as when they left the muzzle of the piece, and, having

less velocity, they met with less resistance or reaction, and consequently, their original elongated shape being less altered, they penetrated furthest of all.

"We have here a beautiful and very instructive illustration of the law of action and reaction, as also of the doctrine of *inertia*, which deserves a passing comment. Bodies in motion continue in motion from the inertia of motion; bodies at rest continue at rest from the inertia of rest; that is, bodies which move do move, bodies at rest are at rest. This is all. The idea receives colouring from two very important facts. First, the progressive motion of a mass is in proportion to the force impressed, and takes place after a lapse of time from the application of the force to the atoms of the body. There is needed time for the force to be diffused among the atoms by atomic motion, before consentaneous or progressive motion is induced. The other fact is, that in most cases force in moving bodies is gradually applied. Thus a ball fired horizontally over water, with a very small charge, will enter the water when it first touches it; for it can, as it were, await the tardy resolution of the atoms of the water into progressive motion to give it place. But when the ball is fired with a full charge, it is deflected, or ricochets. Its velocity is so great that it cannot transfer its force; for it would take many instants for the particles of water, moving with the same velocity with the bullet, to travel through their atomic space, and to induce progressive motion of the column necessary to be moved for the passage of the ball through the water.

"So it is with sand, wood, iron, &c., for the destruction of velocity is in all cases gradual, and the time employed will depend most materially on the nature of the substance on which the bullet impinges. The force which the ignited gunpowder generates after having put a bullet in motion and produced its full effect remains, as it were, inclosed in the bullet; and the joint product of the velocity and of the quantity of matter in the bullet represents the result. This joint product is termed the momentum of the bullet. In order, therefore, that the shot should produce the greatest effect, we must move the muzzle of the piece near to the object aimed at; and the nearer we move it the *greater the*

effect will be, as the retarding influences of the air will reduce the momentum of the shot every instant afterwards. But then comes the question, which appears to have been very much overlooked; will the *effects* produced be *beneficial* or not? If we wish to obtain the deepest penetration, the bullets fired at the shortest distance answer, No.

“In forming our opinions of the effects produced, we must, however, guard ourselves against taking a one-sided view of the case, which the examination of the sand *alone*, or the firing of small shot against pasteboard, would certainly cause. It is important to remember that time is necessary for the destruction of momentum, or rather of velocity; and the less the time which is employed, the greater must be the effort exerted; or, in other words, ‘the force requisite for the destruction of any velocity is greater as the time occupied in its destruction is less.’ It is evident, then, that the bullets which penetrate the shortest distance require less time to do so than the others, and that, therefore, more force is exerted. This, however, must be considered with reference only to very short ranges; for at ranges greater than 200 yards the penetration will be less, in consequence of the reduced velocity of the shot, which is caused by the longer resistance of the air. It will, therefore, be found that every kind of gun, rifle, &c., has one particular distance at which it can do most execution, and this distance can only be ascertained by making experiments on various substances, at different ranges, with various weights of shot and different quantities and qualities of powder. And though it may appear somewhat paradoxical, it is nevertheless true, that one gun will *not* cause its shot to penetrate so deep as another at a particular range, simply because it shoots too strong, or with more velocity than the other, the action of the shot and the reaction of the substance fired at being equal.”

VARIETIES IN THE FORM OF THE GROOVES ALMOST INFINITE.

The use of a spiral groove in some form is extremely old, and since its first introduction the varieties of shape which have been tried are beyond calculation. The number of

grooves, their form, and the quickness of the twist, have all varied as far as it was possible; and by the Americans a twist increasing in quickness has been very generally adopted, their chief writer on the subject (Chapman) strongly insisting upon it. But whatever may be the plan adopted, unless the workmanship is good and true, it will not succeed; while, on the other hand, if the grooves are well cut, the rifle will shoot well with almost any of the methods of rifling which are now adopted by the chief authorities on this subject. The arguments for and against each of the rival plans at present in vogue would occupy many pages, and after all they would, perhaps, lead to no satisfactory solution of the problem. Much practice is required in adapting together all the elements upon which success depends, for barrels and grooves which will suit one ball will be useless with another, and *vice versa*. Now, as every rifle-maker has his fancy, and as he will have brought all his experience to bear upon it, the best plan is to accept him and his work with all faults, instead of interfering with him. If you go to Purdey for a rifle, you will get one with two grooves, the shooting of which will be equal, if not superior, to any which can be brought against it; while if he took your order for a three-grooved rifle, it would probably be inferior to those made by many gun-makers of a celebrity far inferior to his.

RIFLE BARRELS.

The barrels of rifles are either made of twisted iron, as described for shot-guns, or they are forged of solid steel, and afterwards bored; or they are made with a longitudinal line of welding, if they are intended for common purposes. The first is the plan always adopted for double barrels, which would be too heavy if made out of the solid. Solid steel barrels are used where weight is necessary to resist recoil or vibration, and if very accurate shooting is required, they are superior to all others. In either mode, a perfect cylinder is first obtained, which is afterwards rifled on the plan to be presently described. The weight of the Enfield barrel (4lb. 2oz.) is the lowest for the length (3 feet 3 inches) compatible with safety and efficiency.

THE METHOD OF RIFLING.

There are several machines by which the spiral grooves may be cut in the interior of a barrel, but all proceed upon the principle that a cutter of the shape of the groove is passed backwards and forwards in a spiral manner through it, the barrel itself being fixed. The annexed engravings show one of the best and most simple plans adopted by Messrs. Prince and Green in London, and by Mr. Rigby in Dublin. Fig. 66

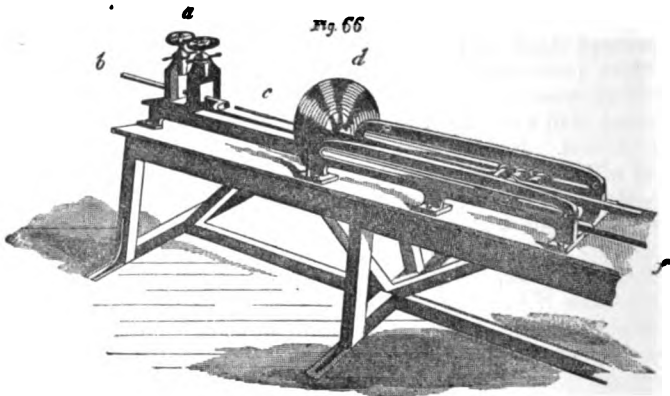

RIFLING MACHINE.

represents a strong iron table upon which are fixed two slotted frames. One of these *a* has two sliding vices travelling on it, and capable of firmly securing the barrel *b* ready for the cutter *c*. This is attached to a rod which passes through a square hole in the plate *d*, and is driven backwards and forwards in a perfectly straight line by the rollers working in the two slots *e e*. The strong rod *f*, figs. 66 and 67, is made to work backwards and forwards by the wheel shown in fig. 67, the horizontal line being preserved by the slots *e e*, fig. 66, and the hole in the centre of the plate *d*. Here, then, we have a very simple plan for producing a steady yet powerful horizontal motion for the rod which carries the cutter, and which in the ordinary way

would cut a *straight* groove through the barrel on one of its sides, if passed backwards and forwards through it. Next come the two problems, first, how to cut a spiral instead of a straight groove? and, secondly, how is this spiral to be made quick or slow? That is, how shall we form a turn in one foot, two feet, three feet, &c., at discretion? It must be noticed that the section of the rod is square, and that it passes through a square hole in the plate *d*. Now, by

Fig. 67.

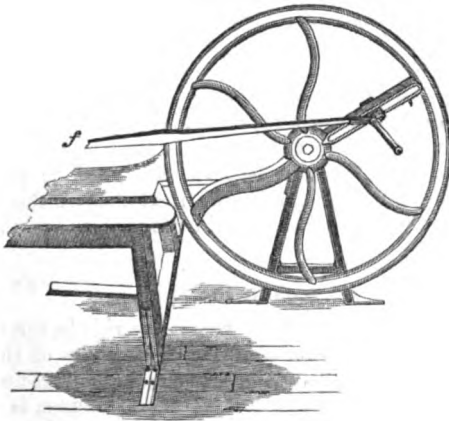

DRIVING-WHEEL OF RIFLING MACHINE.

twisting this square rod on itself, the cutter attached to its extremity, as it glides through the hole, takes a corresponding twist, and if this is made one in three feet, the groove will be cut exactly of the same twist. Thus we have both problems solved. The twisting of the rod causes the groove to be spiral, while the amount of its twist settles that of the barrel. We have thus shown how one groove is made, and all that is necessary in order to cut two, three, or any other number of grooves, is either to keep the barrel fixed and alter the position of the plate *d* for each groove, or to let the plate remain, and move the barrel in a corre-

sponding manner. Both modes are adopted by different makers, but in the machine shown in figs. 66 and 67, the plate is made to revolve, and each of the circles shown upon it is divided accurately into either two, three, four, five, six, seven, eight, or nine equal sections, so that if a barrel is to be cut with three grooves, the circle with three equal divisions is used, and the plate being moved in exact correspondence with them, the work is beautifully correct. So also the shape of the cutter determines the form of the groove, being nearly semicircular for the oval bore of Mr. Lancaster, as shown in the engraving illustrating Captain Beaufoy's celebrated work, "Scloppetaria." Again, for a groove with sharp angles, the cutter is made correspondingly sharp, for as it traverses backwards and forwards, it leaves its mark exactly of its own shape, allowing for the slight vibration inseparable from the working of a rod confined at one end only.

The principle, therefore, upon which all rifle grooves are made is the same, though in the next chapter the variation will be shown to be immense in the modes by which that principle is applied.

TECHNICAL TERMS.

One of the most important defects in a rifle is, the existence of such a space between the ball and the sides of the barrel, or of its grooves, as to allow of an escape of gas generated by the explosion of the powder. This, of course, is attended with a corresponding loss of power, and is known among rifle makers and shooters by the term "*Windage*." I have already, at p. 306, given a definition of "upsetting;" but there are three terms constantly used in rifle shooting which require some notice here. These are—1st, "The line of fire;" 2nd, "The aim;" and 3rd, "The trajectory." The *line of fire* is the indefinite projection of the axis of the barrel. The *aim* is a straight line drawn from the centre of the back sight to the top of the front one, and prolonged to the object at which the rifle is directed. Lastly, the *trajectory* is the curve actually described by the ball in its passage through the air, and greater or less in proportion to its velocity.

CHAPTER II.

THE MUZZLE-LOADING SPORTING RIFLE.

GENERAL REMARKS—PURDEY'S TWO-GROOVED RIFLE—THE SINGLE AND DOUBLE BELTED BALL—THE ENFIELD RIFLE AND PRITCHETT BALL—LANCASTER'S OVAL SPIRAL—GENERAL JACOB'S FOUR-GROOVED RIFLE—THE FOUR AND FIVE-SIDED BORE, WITH ROUNDED ANGLES OF MAJOR NUTHALL AND MR. BOUCHER—WHITWORTH'S HEXAGONAL RIFLE—HENRY'S RIPLING—THE RATCHET WHEEL GROOVES—VARIETIES OF BALLS—SINGLE AND DOUBLE RIFLES.

BEFORE proceeding to discuss the merits of the various kinds of rifle, it will be well to examine each in detail, selecting those which can be at all useful to the sportsman; but in doing this it will be necessary to consider with them the balls which they respectively carry. I have already, in the previous chapter, described the principle upon which all rifle barrels are constructed; but it now remains to consider the questions depending upon the best number of grooves, the proper amount of twist, and the shape of the ball which shall be used with each; all of which subjects have been partially explained in the first chapter, but the bearing of one on the other has not been sufficiently taken into consideration. Thus, it is well known that a very long ball requires a greater twist in the barrel to prevent its upsetting, which again necessitates a larger charge of powder. On the other hand, a short ball will fly correctly without so much twist, and with less powder, the friction in its case being proportionately lessened. I shall therefore pass in review the various balls and grooves in common use with the muzzle-loader, leaving the description of those applicable to each breech-loader to the division appointed to them.

MR. PURDEY'S TWO-GROOVED RIFLE.

Foremost in simplicity and in established fame stand Mr. Purdey's rifles, to possess one of which has been the object of most deerstalkers and rifle shots for many years. The

FIG. 68. DOUBLE-BARRELLED PURDEY RIFLE.

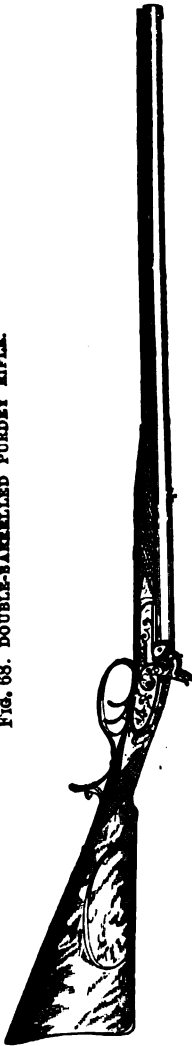
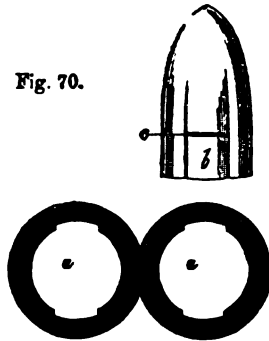

FIG. 69. PURDEY RIFLE. (ONE THIRD SIZE.)

annexed engraving represents an exact imitation of a rifle belonging to a very celebrated deer-stalker, made by Mr. G. Smith, of 40, Davies-st., Berkeley-square, who was many years with Purdey, in the rifle department, and who, I fully believe, will build as good a rifle at fifty-five guineas as can be procured at his late master's for ninety guineas. The original of the sketch was shot at the gun and rifle trial in 1859, and performed the best at 100 yards; but from a mistake in the charge of the first four shots, all of which missed the target, "she" was beaten at 200 yards. These rifles are all made with two grooves, the balls being of a sugar-loafed form, and cast with two wings to fit the grooves. Fig. 68 gives a full-length view of the left barrel and lock, and shows also the usual cheek piece. Fig. 69 is a somewhat larger sketch of an octagon single-barrelled rifle, by the same maker, with similar grooves.

Fig. 70 *a a* represents a section of the two barrels, of the exact size adopted, the bore being forty, and the grooves being wide and very shallow; they are accurately fitted by the wings on the ball *b*. On the wing itself there is a very slight shoulder *c*, three-eighths of an inch from the base, and this giving way beneath the ramrod ensures an exact fitting of the ball to the groove, so as to avoid windage altogether. The turn is one in six feet, and for sporting purposes at sporting ranges—that is, at anything not exceeding 300 yards—this variety is, in my opinion, one of the best, as it gives a sufficient spin without any unnecessary friction, and very little elevation of the sights is required. The weight of the whole rifle is 8½ lbs.; length of barrels, 32 in.; bore 40. Weight of ball, ¾ of an ounce; charge of powder, 2¼ drs.



SECTION OF PURDEY RIFLE, AND VIEW OF BALL.

THE ORDINARY TWO-GROOVED RIFLE.

Next in simplicity, but far inferior in efficiency, is the two-grooved rifle, intended for the old spherical ball, with a single belt fig. 71 *a*, or with a cross belt, as in fig. 71 *b*; but these are now almost entirely given up in favour of Purdey's ball, or of some one or other of those which I shall presently describe.

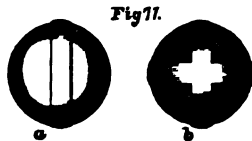

BELTED SPHERICAL BALLS.

THE ENFIELD.

Thirdly comes the Enfield rifle, which has three grooves, cut slightly deeper at the breech than at the muzzle, and

making one turn in 6ft. 6in. The barrel being 3ft. 3in., it follows that only half a turn is made in that length. The bore has a diameter of 577; charge of powder, $2\frac{1}{4}$ drs.; and weight of bullet, 520 grains; the shape being cylindro-conical, with a boxwood cup inserted at the base, but many are now used with a mere hollow cup in that part, and known as the Pritchett ball. The Enfield rifle is well adapted for sporting purposes, but requires considerable care in adapting the bullet, as it often happens that very great force is required in ramming it home when the interior is allowed to become choked with powder.

THE OVAL SPIRAL, CLAIMED BY LANCASTER.

Fourthly may be mentioned, the smooth oval spiral bore, adopted by Lancaster, but which appears clearly to be a reproduction of a plan published by Capt. Beaufoy in 1808, his book "Scloppetaria" containing not only an allusion to the plan, but also describing the mechanical details necessary for carrying it out. The following extract from p. 87 will satisfy any candid mind of the truth of this assertion: "But while we are thus enlarging on rifles with grooves, let us not pass over a very old invention, though quite obsolete in our time, which is the method of making a plain barrelled gun possess the advantages of a rifle, and yet not be liable to detection unless more minutely examined than common inspection usually leads us to expect. Having selected a barrel, of rather thicker metal than those usually made, let it be placed in the rifling bed, only in lieu of having a saw, substitute an elliptical file at the end of the rod. The file instead of being solid should be divided down the middle longitudinally, and attach the pieces one on each side of the rod, &c., &c., &c. These barrels are loaded in the usual way, excepting that the ball used should be sufficiently large to fill up the whole of the indentation; and it is said that such as are accustomed to these pieces will far outstrip anything that can be done with the common smooth-surfaced cylindrical barrel. *It would be an improvement, though, instead of using a spherical ball with these pieces, if it were rather of an oblong shape.*" It is therefore clear, that whatever credit is due to this plan belongs to Captain Beaufoy, not as the inventor—

for he does not claim it as his own—but as the first to lay it before the public. Great promises have been held out by the advocates of this mode of rifling; but in practice I have seen so many balls go whistling away in some unforeseen direction, that though at other times I have known good practice made, I could never place any confidence in the principle. It is said that Mr. Lancaster has lately attained a range of 3000 yards, with this form of rifling.

GENERAL JACOB'S FOUR-GROOVED RIFLE.

Fifthly, we have General Jacob's ball, which resembles Purdey's in its wings, but has four instead of two of them. The twist is four-fifths of a turn in twenty-four inches, or more than double that of Purdey; so that, though an increased range is obtained with it, the charge of powder must be greater in proportion, and the recoil is by no means pleasant. The gauge is 32. This rifle does not seem to have any advantage at sporting ranges; but for military purposes it has been strongly recommended, especially in reference to the explosive shells which are used with it. In 1856, a report upon General Jacob's rifle was made to the Indian Government, which states, "that at ranges from 300 to 1200 yards the flight of the shell (used with this rifle) was always point foremost, and the elevation at the extreme range inconsiderable. The shells which struck the butt invariably burst with full effect; and practice was made by the many officers who attended, at distances which could not have been attained with any other missile." The shells alluded to in the report require a short stout barrel, and cannot be used with a long thin one, like the Enfield. For killing large animals, like the elephant or rhinoceros, they are peculiarly qualified; and I should strongly recommend elephant hunters to examine into the merits of this rifle, as made by Mr. Daw, of Threadneedle-street, London, who received his instructions from the late General Jacob.

MAJOR NUTHALL'S AND MR. BOUCHER'S.

Under the sixth division may be mentioned two rifles very similar in their principle, but one having four sides, with



MAJOR NUTHALL'S RIFLE.

rounded angles, slightly varying in form (see fig. 72 *a b*), and the other five (fig. 74). These are respectively the

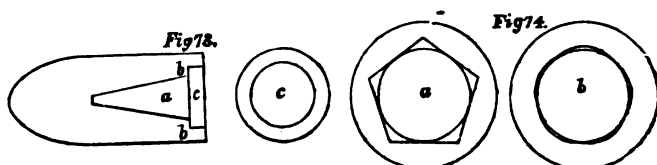

MR. BOUCHER'S BALL.

SECTION OF MR. BOUCHER'S RIFLE.

plans of Major Nuthall and Mr. Boucher; but the latter having published full particulars in the *Field* of May 14th, 1859, (while Major Nuthall's was not patented for some time afterwards,) he is entitled to the priority in the merit of the invention if the two prove to be similar in all other respects, as I believe they are. Mr. Boucher also specially alludes to the four-sided plan with an unfavourable mention; but, to avoid any risk of mis-statement on my side, I will give his letter entire, as far as it relates to this subject:—

“Surrey Villas, Camberwell.

“I am an advocate for a somewhat heavy rifle, as the shooting with such a weapon is always more steady, with less recoil; particularly if the weight of the metal is judiciously accumulated behind and immediately surrounding the breech. The barrel of the one I am now about to describe is 2 ft. 6 in. in length; weight, 5½ lbs. The bore is exactly half an inch in diameter—a size which the great majority of our practical marksmen agree now in recommending. I am not favourable to four grooves, for this reason: when the bullet leaves the muzzle of the piece, it is made by the force of the explosion nearly *square*, or four-

sided, especially if the grooves are deep, causing a considerable amount of extra friction, and consequently retardation by its grinding motion, while passing through the air. I have therefore fixed on five, though, from my style of grooving, many have supposed the barrel to be a smooth-bore.

"In order to understand the mode of grooving thoroughly, I must ask the reader to draw for himself, on as large a scale as he pleases for the sake of distinctness, the geometrical figure called a *pentagon*. Then, in the centre, let him draw a circle, so that its edges may just *touch* the sides of the figure. This circle is to represent the end of the bullet. The next process is to round off the angles of the figure to rather less than a *third* of their original depth, when they will appear to be *broad, shallow grooves*, somewhat like the second diagram above; the first diagram representing the figure before the angles were rounded off.

"The twist of the spiral is at the rate of one turn in five feet, which generates a rotary motion quite sufficient for a range of one mile, for, as there is little friction, comparatively speaking, to retard the progress of the bullet *in* the barrel, it proceeds with greater velocity after leaving the muzzle, thus rendering a less amount of twist necessary than in a barrel having more friction.

"Taking into consideration all the experiments I have made myself, all I have witnessed in other quarters, and all the experimental reports I have read on the subject, this is the mode of grooving which I still prefer, and which I recommended to our authorities in the autumn of 1853, and again in 1855. I have loaded and fired hundreds of rounds from such a barrel without the slightest trouble, the last bullet going down as easily as the first; in fact, a glance at the diagram will show any man conversant with the subject that there can be no friction that cannot be overcome by merely *pressing* the ramrod gently and steadily down, so that the shape of the bullet cannot be destroyed, nor the powder caked, by the bullet being jammed down upon it.

"This mode of grooving requires only *attention* on the part of the workman, without which any sort of grooving becomes worse than useless, disappointing and deceiving the man who

pays a high price for a showy and, *said to be*, superior weapon. The cutter should be just a fifth of the circumference of the bore, and very shallow, and care taken not to go so deep as to affect the five points of the original surface where the bullet is seen to touch the sides, leaving the bore without any sharp edges. I have enclosed you a bit of lead, which I have driven into the barrel; you will feel, by rubbing your fingers over it, that it is nearly smooth, though on looking at the end you will at once perceive the mark of the five hollows or grooves that grasp and guide the bullet while turning and passing through the barrel.

"My 'disc bullet'—the one I recommend for such a barrel—is what is commonly called *Cylindro-conoidal* in its outward form. That which I generally use is about 1 1-16 inches in length, as represented by the diagram; though it may be made longer if the rifleman desires a heavier one for particular purposes.

"In the end of the bullet, which is a *fair* cylinder for half its length, I have a cavity formed as shown at *a*, which extends a little more than half the length of the bullet. Upon the edge of the cavity *b b* I place the round disc *c*, which is cut out of thin iron to fit exactly, so that it will not drop out after it has been pressed in by the thumb or gently on a table. When the explosion takes place, the disc becomes so firmly fixed by the contraction of the lead around it that it never falls out, nor is it driven, or intended to be driven, further in than the rest of the lead at the base of the bullet.

"Experience shows that the 'disc' bullet rifles itself as distinctly as if it had been cast in the grooves of the barrel: a complete answer to the *supposed* effects of all such nonsense as the 'expanding' cups and plugs which many, who ought to know better, still believe in. It may also be called a *safe* bullet, for any number may be fired at a distant object over the heads of bodies of men employed or moving in the intermediate space, without any fear of the discs leaving the bullets, like the cups of the 'Minié,' and injuring the men. I have fired thousands of these bullets, and, though not a first-rate marksman, I have repeatedly placed 70 per cent. of them in a space two feet broad by four feet high, at 600

yards distance. This can be corroborated by unquestionable authority.

“Mr. Greenfield, of Broad-street, Golden-square, has been in the habit of making my bullet-moulds, and, as my object is to encourage rifle-shooting, he has full permission from me to make moulds of this pattern for any gentleman applying for the same. In giving the order, however, I would recommend the barrel to be given to him, with instructions to make the bullet large enough just to touch its sides, but to fall to the bottom by its own weight. My reason for advising this is, that I never use paper or patch, but simply dip the bullet half way in a *very hot* mixture of two parts bees'-wax, one part soft-soap, and one part tallow or hogs' lard, the refuse being previously carefully skimmed off. I generally mix a few pounds of these ingredients together at once, as it has then only to be made thoroughly hot and liquid for use at any time afterwards.

“Some years ago, when carrying on an extensive course of experiments, with bullets of various sizes and forms—some with paper wrapped round them like the Service ammunition, some with patches, and others in a *naked* state—I became so satisfied of the superiority of the ‘naked’ bullet, and its simplicity in loading, over other methods, that I have continued ever since to use such for my own private shooting. Our most scientific military authorities have also lately declared themselves in favour of this system. One says: ‘The employment of a naked bullet, thus doing away with that interfering medium, the paper, will be a matter of great importance if we can succeed.’ Another says: ‘I entirely concur in what has been said as to the advantages to be derived from the naked bullet in preference to one with paper; it is evident that the naked bullet properly supplied with grease will fill the grooves of the rifle better than one which has the intervening substance of paper around it.’ A third adds: ‘In my opinion it is to the paper alone the defects in fouling and accuracy are attributable; bullets have lately been constructed and used without paper, and the result has been that these bullets have not only shown themselves superior to the plug, but barrels which would have been rejected with the latter as bad barrels

have produced greater accuracy than has ever been obtained with the plug ammunition.' These are the opinions of officers of high standing, who have devoted much time to the study of rifled arms, and are therefore worthy of every consideration.

"In my next I purpose giving a description of some other contrivances, which I consider improvements, together with a few remarks in connexion with their use. I shall also be happy to answer any questions on the subject of rifle-shooting, if space is granted me for that purpose; but, as I shall endeavour to give scientific *reasons* for everything I say or advise, I trust that those who may be disposed to differ from me will do the same; thus placing it within the power of many of your inquiring readers to judge and decide for themselves.

"J. BOUCHER."

On the other hand, Major Nuthall's grooving is represented in the annexed section, the original of which was kindly furnished me by himself. The rifles on this plan have been used with his own bullet, which has a very wide cannellure, and also with the regulation ball, but as far as I know, without any very great advantage in point of accuracy. Mr. Boucher's I have lately tried with the happiest results, and I am inclined to believe that there is no form of rifling superior to it.

THE WHITWORTH RIFLE.

Seventhly, we have the *hexagonal bore* of Whitworth, which has attracted a great deal of attention, and which, when carefully made, is capable of effecting excellent shooting. But if the ball used is also hexagonal, as at first made by Mr. Whitworth, it fits into the angles so accurately, that the

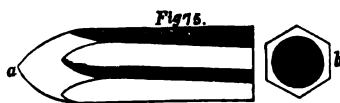

WHITWORTH HEXAGONAL BALL.

slightest amount of fouling interferes with the loading. Fig. 75 shows the shape of this ball by means of a view in profile at *a* and of the base at *b*, both being slightly

reduced in size. Within the last two or three years, however, the celebrated inventor has altered the shape of the section of his barrels. At present (1861) they are made with rounded angles, necessitating also a corresponding shape in the balls if they are cast to fit them. The following engraving, fig. 75* *a*, shows an exact section of the bore, and serves also to indicate the form of the hexagonal ball, which is now, however, very rarely employ-d with it. The ordinary Whitworth ball is a plain cylinder, $\cdot 425$ of an inch in diameter, and an inch long, terminated by a blunt elliptical point, not quite half an inch long, as represented at *b*. At

Fig. 75*.

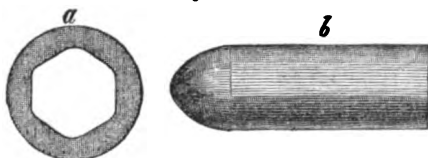

PRESENT WHITWORTH BORE AND BALL, FULL SIZE.

the base is a thimble-like depression a quarter of an inch deep. Thus the ball is as near as may be three diameters in length, and its weight is 530 grains. It is, I believe, made by compression, not casting, and is carefully swedged. Mr. Whitworth uses it with a thin paper covering extending over the whole of the cylindrical portion, and between it and the powder he introduces a wad of solid grease. The barrel is made moderately stout, and of what is called homogeneous iron; that is to say, not twisted or made of more than one quality, as in Damascus or laminated steel barrels. The bore is $\cdot 451$ of an inch, and the twist one in twenty inches. In testing the comparative advantages and disadvantages of the hexagonal and cylindrical balls, it has been found that in point of accuracy the latter bear away the palm, and that the former can only be recommended when a harder metal than lead is required. Hence, for target shooting, the cylindrical form is now universally employed, and for long ranges it gives excellent results; equal, if not superior, to any other. General Hay is said

to have made a 17-inch string at 1200 yards in twelve shots; but whether this was a lucky series or not, selected out of a great many others, I have no means of ascertaining. The charge of powder varies from 70 to 80 grains, according to the range required; and I believe Mr. Whitworth uses Curtis and Harvey's No. 6.

HENRY'S RIFLE.

Within the present year a new form of rifling has been introduced by a well-known Scotch gun-maker, which has performed in public at long ranges as well as or better than any other. It consists of seven wide grooves with sloping sides, so cut that they leave a heptagon with projecting

Fig. 75**.

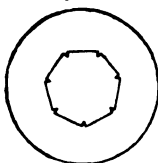

SECTION OF
HENRY'S RIFLE.

wedge-shaped lands, terminating in sharp points, as rendered in the annexed diagram. (Fig. 75**) The bore and twist are the same as in Whitworth's rifle, and the ball used is identical with his, and covered with paper in the same way. Indeed, I believe Mr. Henry uses the very balls sold by the Whitworth Rifle Company. At 800 and 1000 yards this rifle showed to great advantage at the Hythe trials last February; but it was used with very large charges of powder, to the extent, I believe, of $3\frac{1}{2}$ drachms. From the shape of the grooves I should suspect that the reason for this is, that there is great windage on each side the pointed lands; but this is counterbalanced by the certainty of their laying hold of the ball, and thus avoiding all chance of stripping. I have seen some of the balls shot from this rifle into water, and caught in a blanket, by the direction and under the superintendence of Lord Vernon, which clearly indicate the precision with which they have taken the points. They were shot with some of Whitworth's and Westley Richards', and show a decided superiority over both in this important particular. To counterbalance these advantages, it must be borne in mind, that the slightest bruise with a metal ramrod will destroy the truth of the pointed land; and that if a burr is thus raised near the muzzle, all true shooting is put an end to. I have never

seen this method of rifling tried at short ranges, and I cannot therefore speak of its merits for sporting purposes.

THE RATCHET-WHEEL OR FEATHER-EDGED GROOVE.

Within the last three or four years a very old plan of rifling has been revived and improved upon, which promises great things. Its principle consists in having the non-driving edge of the groove cut much more shallow than the working one, whereby not only is friction diminished when the ball is in the barrel, but also as it passes through the air. It may be used with any number of grooves, but if with four, the section is as follows. In the old ratchet-wheel groove an angular cut was made with straight sides and a sharp edge, instead of the curves shown in the annexed section, the inventor of which I do not know.

Fig. 75***



RATCHET-WHEEL GROOVE.

VARIETIES OF BALLS.

But besides these varieties in the rifling, there are also several different kinds of ball applicable to most of them. Originally all bullets were spherical, next to which came the sphere with a band, and afterwards two bands upon it. It then became egg-shaped, and in 1836, Mr. Greener invented a ball and plug, which he then described as follows:—"An oval ball, with a flat end and a perforation extending nearly through it, is cast, a taper plug with a head like a round-topped button is also cast, of a composition of lead, tin, and zinc, as shown in fig. 76 *a* and *b*. The end of the plug being slightly inserted into the perforation, the ball is put into the rifle or musket with either end foremost. When the explosion takes place, the plug is driven home into the

Fig 76.



GREENER'S BULLET.

lead, expanding the outer surface, and thus either filling the grooves of the rifle, or destroying the windage of the musket, as the case may be. The result of this experiment was beyond my calculation; and for musketry, where the stupid regulations of the service require three sizes of ball difference for windage, it is most excellent, as remedying this considerable drawback upon the usefulness of the arm—as the facility of loading is as great, if not greater, than by the present. As regards its application to rifles, there can be no question of its advantage if there exists any requirement for the ball to be acted upon by the grooves at all, *which I do not think is advantageous—in fact, there exists no question.* This ball was rejected by the then existing Government as “a compound,” and lay dormant until Captain Minié invented a plan of expanding a ball on somewhat the same principle by means of a metal cup, which is sunk into a chamber twice as deep,

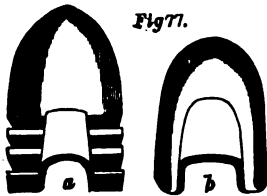

Fig 77.

CRENULATED AND PLAIN
CYLINDRO-CONOIDAL BALLS.

but so arranged that the cup does not project from the base of the bullet. (See fig. 77 a and b.) The former is the French bullet, having three cannelures, the latter being the English pattern without them. For a time this invention was thought to be of great value, and, being adopted in the English service, Mr. Greener laid claim to a compensation, and

obtained it to the extent of 1000*l.*, although it is quite clear that his bullet in its original form, as tried by the Government officer, differed in many essentials from the pattern afterwards adopted, and particularly in not having the centre of gravity always in front, because he expressly says that it might be fired either end forward; and, moreover, the plug being only slightly inserted in the socket, it was liable to be driven home by the ramrod in forcing the bullet down the barrel as soon as this had become foul. Hence, although it certainly contained the germ of the invention to a still greater degree than Captain Norton's hollow shell previously invented, it was in a perfectly useless state when discarded by the Government; and, moreover, it was

expressly declared by Mr. Greener in 1841 that he did not think the expansion into the grooves was advantageous to the rifle, in the paragraph inserted above, in which the italics are my own. Lancaster and Wilkinson then tried the cannellured bullets, in slightly varying forms, and made good shooting, increasing at the same time the sharpness of the spiral and the charge of powder to counteract the retardation caused by them in the flight of the ball. Then came Pritchett with his conical balls (fig. 78 *a* and *b*), having a depression in the base, which, allowing the powder to expand it, rifles the surface in contact with the spirals.

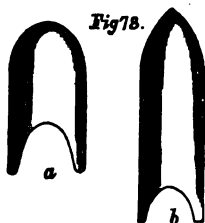

PRITCHETT BULLETS.

Lastly, we have the Whitworth ball, which has been already described as hexagonal, and slightly twisted on itself to fit the rapid spiral used with it. (See fig. 75.)

SINGLE AND DOUBLE BARRELS.

Such are the variations in principle of the muzzle-loading rifle and the bullets used with it, but there are also some practical modifications of the former which require to be considered. In the first place, there is the choice to be made between the double and single barrel, and if the latter is adopted, it may be a solid bar of steel bored, or of twisted iron, like the shot-gun described in the last Book. The double-barrelled rifle is never made out of solid steel, on account of the weight and bulk which would attach to so large a mass of metal. In any case, however, the metal must be hard, and steel in some form is almost always adopted. It is obvious that where two barrels are put together, both cannot be directed with the same sight at the same spot and at all distances, for though it may be possible so to arrange two barrels that at any given distance they shall both throw a ball into the centre of the bull's-eye, yet at any other the two balls will be wide of it. Still, General Jacob was of opinion that for all distances his double rifle was superior to his single barrel; but I have never met with any one who took the same view. Whether with one barrel or two, any of the bullets described

above may be used, and any bore and method of rifling may be adopted.

Mr. Nock some years ago invented a new mode of adapting the hammers of single rifles so as to keep them out of the line of sight. This is effected by making them in the form and in the situation of the trigger-guard, the nipple being beneath the barrel. The plan, however, never became general.

CHAPTER III.

BREECH-LOADING RIFLES AND REVOLVERS APPLICABLE TO SPORTING PURPOSES.

GENERAL REMARKS—PRINCE'S RIFLE—TERRY AND CALISHER'S—RESELL'S—LEITCH'S—WESTLEY RICHARDS'—THE LANCASTER—NEEDHAM'S—THE LEFAUCHEAUX—BASTIN'S—GILBERT SMITH'S—THE FIELD RIFLE—WILSON'S—MACKENZIE'S—PEA RIFLES—SHARPE'S—REVOLVERS.

THE same advantages which attend upon the breech-loading shot-gun may also be claimed by the corresponding method, when adopted for the rifle—that is to say, the breech-loader is more quickly loaded, more safe, and more easily cleaned. There is, however, in some plans a considerable escape at the breech, which will condemn them for sporting purposes, while others have such an amount of recoil as to make them most unpleasant to the shooter. I shall therefore omit those which are guilty of these faults altogether.

In correctness of shooting at sporting ranges I am quite satisfied that the breech-loader will compete with the muzzle-loader, or if there is any advantage in favour of the latter, it is so trifling as to be practically of no value. If it is desired to hit a turkey's head at 100 or 200 yards, it is quite possible that the old tool is the best, but if at either of those distances the sportsman is satisfied with putting his balls into a three or four-inch bull's-eye, the new one is capable of doing it, and has done it in my presence on several occasions. The following are all the varieties which are at all likely to be useful to the sportsman.

PRINCE'S RIFLE.

Of all the various breech-loaders, where one barrel only is required, this is, in my judgment, the best, for after admitting the charge at the breech, the barrel is screwed on again almost as firmly as in the patent breech, the only difference being that there is one thread instead of five or six. In practice this one thread is all-sufficient, and it is found that when well made and case-hardened no ordinary amount of wear and tear will produce the slightest effect upon the metal. But as the principle is incapable of application to a double-barrelled rifle, there is some objection to it for the purposes to which I am now alluding, and the weapon must be taken subject to this fault.

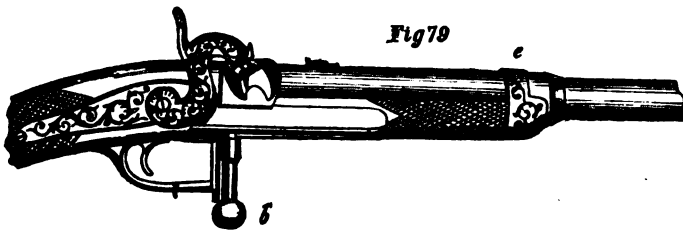

PRINCE'S RIFLE CLOSED.

*The principle may readily be understood by the explanation, that in the case of this rifle the breech and barrel are screwed together by means of a single coarse thread in the latter, and two studs fixed upon the cone, as shown in fig. 80 at *a*. But instead of screwing the breech into the barrel, as is done in the usual way, the latter is moveable, and slides forward after it is unscrewed by the lever *b* working in the slot *c*. In doing this the barrel, though allowed to make a quarter revolution, and afterwards to slide forward, is still securely fixed to the stock by the clip fig. 79 *e* in front, and by the shoulder of the lever behind, while after re-screwing it to the breech it is just as secure, and as incapable of being injured by any force which can be applied as the strongest muzzle-loader. The lock, hammer, and nipple are all like those*

ordinarily used; and it is so arranged that as the nipple slides forward with the barrel, the hammer cannot strike it and explode the cap until the barrel and breech are securely screwed together. Hence there is no possibility of an explosion with an open breech, which is so much dreaded by some of the opponents of the breech-loader, and which may happen to some other kinds. When the barrel is driven forward, as shown in fig. 80, the cartridge is pushed into the chamber at

Fig. 80.

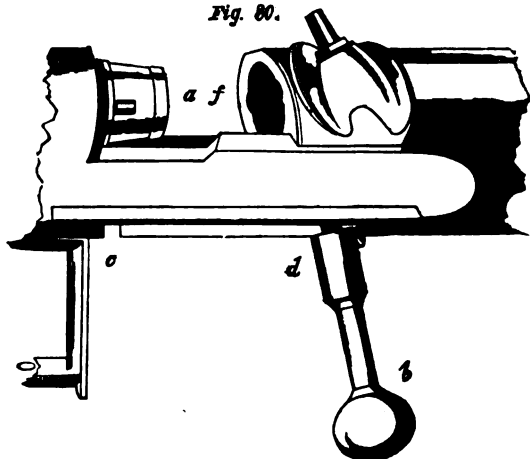

PRINCE'S RIFLE, OPEN.

f, when the lever being laid hold of, and the barrel being drawn back, the former is turned downwards till it is in a line with the front of the trigger-guard (as in fig. 79), and it is only necessary to cap the nipple before the rifle may be fired. The process is so expeditious that eight rounds can be fired per minute. Here, then, we have a rifle which can be loaded in eight or nine seconds, and which is quite as secure and free from escape as the muzzle-loader, while its accuracy of shooting is so great that on a favourable day the palm of a man's hand may be hit nine times out of twelve at 200 yards.

In loading this rifle the stock is held firmly under the right arm, which fixes it against the ribs and leaves the hand at liberty to lay hold of the lever and turn it to the right,

Fig. 81

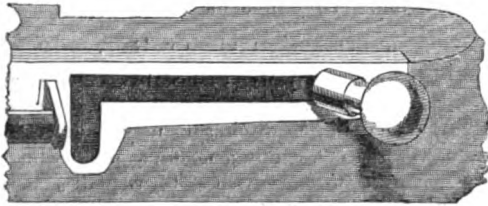

UNDER SIDE OF PRINCE'S RIFLE.

after which it is free to force the barrel forward to the position shown in fig. 80. The cartridge is then pushed into the chamber *f*, and the hand again drawing back the lever and turning it to the left with some little force, the loading is completed. Fig. 81 exhibits a view of the lever and slide from below.

The *cartridges* preferred by Mr. Prince is made of an explosive paper prepared by him. A piece of this is first pasted round the base of the ball, leaving an open cylinder, which is then filled with the charge of powder and tied. Any one can make these cartridges readily enough with a little paste, the only thing necessary after the above-described preparation being to dip the ball and the paper covering it into some melted grease. Ordinary paper will do, but as the fire from the cap has to pierce it, the explosion is not so certain or so rapid as with the prepared paper. Nevertheless, a miss-fire with the common paper does not occur once in a thousand times if the caps are good. Of course they should be those specially made for breech-loading rifles. (See p. 207.)

The *skin cartridges*, invented and patented by Captain M. Hayes, R.N., are particularly serviceable with all rifles which, like this, require the percussion fire to perforate the envelop of the powder. They consist merely of the charge of powder confined to the base of the ball by a fine animal membrane, and kept in the cartouche box in a cover of car-

tridge paper, which is readily torn off by means of a piece of red tape attached to it. Gunpowder thus confined will keep for a long time, and the additional expense is so trifling as to be scarcely worth a moment's consideration to the sportsman. They are manufactured and sold by Messrs. Brough and Moll, London. They must be well greased.

MR. PRINCE'S RIFLE OF 1859.

During the present year Mr. Prince has been engaged in bringing to perfection a new rifle, adapted chiefly to military purposes, by which sixteen discharges may be effected in the minute with the aid of a capping machine, and as long as the reservoir of caps is unexhausted. There will always, however, be more or less escape at the breech, and on that account I think it objectionable for sporting purposes.

TERRY AND CALISHER'S RIFLE.

In Mr. Prince's specification of his patent for his sliding rifle, an exact description of Terry's plan is embodied, and any merit, therefore, which may be connected with it of right belongs to the former, as his patent was completed long before Terry promulgated the one which bears his name. Mr. Prince, however, has abandoned his claim, because I believe he considers the sliding barrel far superior to the piston-breech, and in that opinion I cannot but concur, for reasons which will be better understood after examining the annexed illustrations.

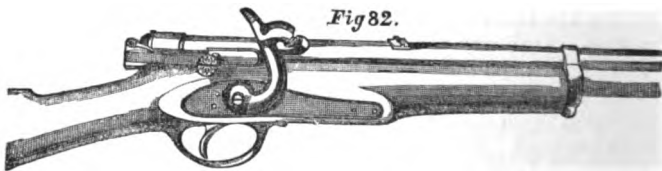

VIEW OF TERRY AND CALISHER'S RIFLE.

In order to prevent any imputation of carelessness or prejudice in reference to a rifle to whose principle I am opposed, I prefer inserting the description given by Mr. Terry himself in the *Illustrated Inventor*, to any of my own:—

"The upper portion of the engraving (fig. 82) shows the elevation of the rifle when charged ready to be cocked and to have the percussion-cap placed on the nipple. Fig. 83

FIG. 83.

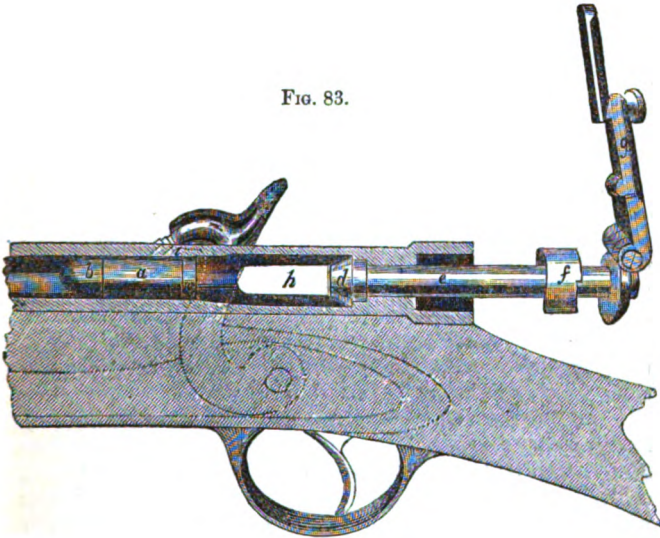

SECTION OF TERRY AND CALISHER'S RIFLE.

shows a longitudinal section of the rifle with the chamber open ready to receive the charge; and for the purpose of fully illustrating it, a cartridge and ball are placed in the position they take previously to being fired. The advantages which the patentee states this rifle to possess are its simplicity and the small number of parts which enter into its construction, its safety, and the impossibility of accident arising from its use with ordinary care; the ease with which it can be loaded, and the rapidity with which it can be fired as compared with any other weapon of the kind at present constructed. There are several peculiarities in the construction of this rifle, and also in the formation of the cartridge, which it will be necessary generally to notice before mi-

nutely describing the details and various parts of which it is formed.

“The cartridge is made of strong brown paper, and is secured to the end of the ball by some adhesive substance; it has glued to the back of it a wad well saturated with tallow for preventing the gun from fouling after repeated use, the action of which will be hereafter explained. By referring to the lower illustration it will be seen that the cartridge is placed directly under the channel or bore which leads from the nipple, in such a position that when the cap is discharged by the fall of the hammer, the explosion of the powder takes place from the centre of the cartridge, and not from the end, as is usually the case. The object of this arrangement is for the purpose of detaining the tallowed wad in the barrel at the time the ball is ejected from it by the force of the exploded powder; it there remains ready to be forced forward by the next ball and cartridge inserted, and leaves the barrel when the discharge again takes place. It will therefore be understood that there is always a wad left behind every discharge, ready to be pushed forward by the following charge. We shall now explain the various parts of the rifle, the way in which they are fitted together, and their action when in use: *a* is the cartridge, *b* the ball, *c* the wad; *d* is a sliding conical piston or plug, operated on by a rod (*e*), and fitting into a seating in which it has been truly ground. Directly at the back of the charge-chamber *f* is a cam, or more properly speaking, an oval collar, formed on the rod *e*, which fits into a corresponding oval recess formed in the breech; and when thus positioned, by turning it one quarter round, the eccentric or oval parts jam themselves into two chambers made to receive them, and form the point of resistance for the back of the charge-chamber; *g* is a hinged joint which, turning round, forms not only a door for the opening *h*, through which the cartridge is placed, but also a lever for more readily turning the cam *f*, and removing the conical piston *d*, when it is required to insert a fresh charge.

“In loading, the operation is extremely easy, and can be performed in a very short space of time—the hinged door *g*, which is kept tight in its place by a spring on the back, is first thrown round at right angles to the position it occu-

pies in fig. 82, it is then turned up again at right angles to its previous position, when the oval collar fitting into the chambers, forming the point of resistance, is at once released, and the whole can be drawn back to the position indicated in fig. 83.

“The cartridge can now be introduced through the opening shown; the piston has then to be pushed forward until the conical part comes in contact with its seating, when the point *g* is forced round one quarter, and then closed over the opening. The gun is now ready for capping and firing. It will be observed that the oval collar is formed something like the twist of a screw; the chamber into which it fits is also formed in the same way; so that when the one is inserted in the other and the quarter turn given by the part *g*, which acts as a lever, it has a screwing action which drives the cone into its seating with considerable force, and thus effectually prevents any escape of the disengaged gases. The bore of the rifle we have illustrated is the same as that of the Enfield rifle, .577 of an inch diameter, being rifled in the same way with three grooves, but having a twist in every 4 feet, whilst the Enfield rifle has one complete turn in every 6 feet 6 inches. The chamber in which the cartridge lies is of the diameter of the circle described by the bottom of the rifling grooves, and the ball used exceeds the Enfield ball in diameter by the depth of these grooves. The barrel has a gradual bore from the larger to the lesser diameter, so that when the discharge takes place the ball is gradually driven into the rifling grooves, and presents precisely the same appearance as an Enfield ball does after it is discharged. In this way the patentee states he obtains greater range, force, and accuracy, with the same weight of ball and powder, than can be obtained by any other rifle. He has submitted it to the authorities at Enfield, Hythe, and Woolwich, and it appears to have undergone the severest test with complete success, and to be generally approved of by those qualified to judge. There is one peculiarity in the construction of the nipple which we had almost forgotten to mention—it consists in boring it in such a way, that the opening next to the percussion-powder in the cap is as large as can be made consistent with safety, gradually becoming smaller until it

arrives at the ordinary size of the bore. By being so formed, a greater explosive power is obtained to burst the cartridge and ignite the charge, while the nipple itself is in no way injured."

By comparing this with Prince's rifle just described, it will be seen that there are two points in which it is inferior to the latter. *Firstly*, it may be discharged with the breech unclosed, which would cause a serious damage to the eyes; and *secondly*, it requires that there shall always be a greased wad in front of the ball, by which the accuracy of the shooting is materially interfered with. Now, as in comparing the two there can only be alleged against these serious drawbacks in Terry's rifle the fact that Prince's barrel is not a fixture, but must necessarily slide, I think a moment's consideration will show that Mr. Prince was quite right in rejecting the portion of his specification which is now taken up by Messrs. Calisher and Terry, and that the rifle which now bears his name is far superior to theirs.

RESTELL'S RIFLE.

Restell's rifle is a Belgian invention, but is patented in this country. The principle is as follows. The barrel is attached to the stock and lock in the usual way, and with an ordinary nipple. Behind the open breech is a short chamber, fig. 84 *e*, in which slides the plug *b d*, with a projection in front at *d*, which closes the open end of the breech. This plug is prevented from sliding in any other than one direction by a stud which travels in a small slot, the end of the stud being shown roughed, just above the lower end of the lever. When this plug is pushed forward, it occupies the position of the chamber *e*, and closes the breech; while, when it is drawn back, it leaves both open and ready to receive a cartridge, which however must be jointed, on account of the shortness of the chamber. The next thing is to provide for the movement and closing of the plug; and these objects are very ingeniously effected, but unfortunately with scarcely sufficient strength. An outside lever *a* is connected with an internal wedge *c*, which lies in a slot in the middle of the plug *b d*, and the shape of the wedge is such that when

the lever moves it round on its axis, the segmental edge represented by the dotted line at *c*, drives the front of the

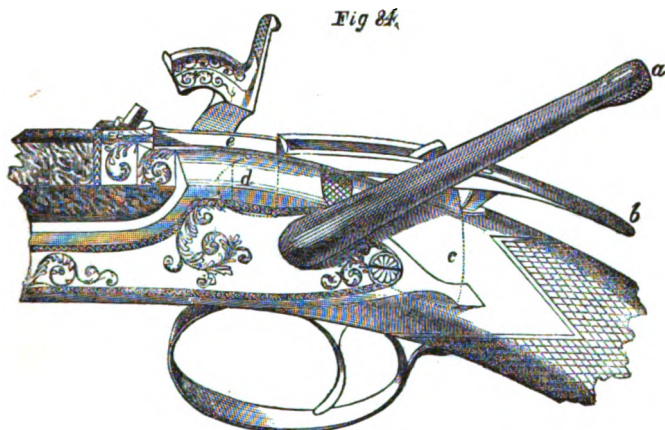

RESTELL'S RIFLE, OPEN. (HALF SIZE.)

plug forward, so as to close the open breech. As in Prince's and Terry's, the fire from the nipple has to perforate the paper of the cartridge. The closure of the breech is well managed as long as the bolt of the lever is not worn; but when this becomes loose by friction, there is some little escape; and as either the bolt or the stock must be greatly reduced in strength beyond what is sufficient to withstand any severe pressure, there is an element of weakness which will always militate against the plan.

The cartridge used with this rifle is of the ordinary construction, but tied in behind the ball, so as to form a narrow neck or joint.

The above drawing is from a rifle made by Mr. Dean, of King William-street, City.

LEETCH'S RIFLE.

Mr. Leetch, of Great Portland-street, London, has exhibited for the last three or four years a breech-loading rifle,

which is constructed on the principle of the revolver, but without more than one chamber. A single chamber (fig. 85 *b*), capable of holding a cartridge complete, is forged in a block

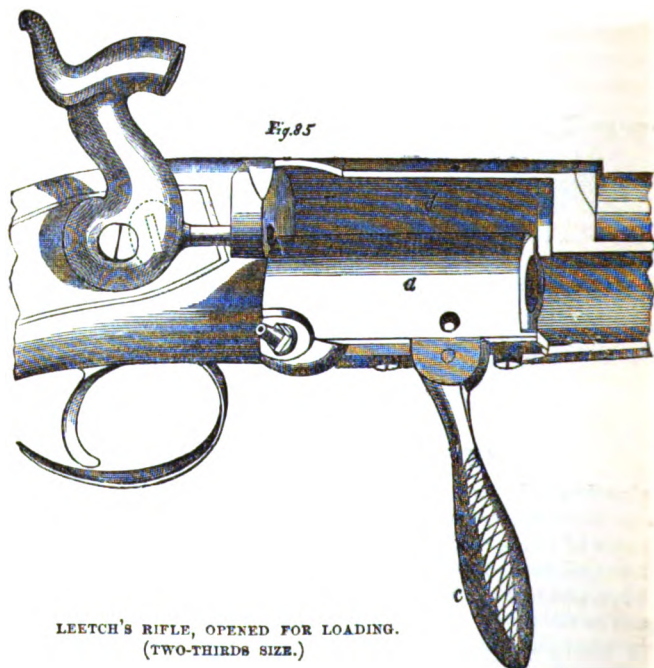

LEETCH'S RIFLE, OPENED FOR LOADING.
(TWO-THIRDS SIZE.)

of metal *a*, and furnished with a nipple. This chamber is hinged so that it readily falls sideways to the right (see fig. 85), on being pulled in that direction by the hinged lever, *c*, exposing the open end of the barrel, and the space *d* between this and the false breech, in which it lies; while its own open mouth, *b*, admits of the insertion of the Government cartridge in the usual way, after which it is turned back, the nipple is capped, and the whole is ready for use. A bolt in connexion with the hammer drops into this chamber, and securely fixes it, preventing the explosion of the cap unless the chamber is secured. This plan is very simple, and I have

seen extremely good practice made at short ranges; but there must of necessity be an escape of gas quite as great as in the revolver, which has the advantage of permitting five or six shots in rapid succession. If, therefore, the escape is not objectionable to the sportsman, I should advise a revolving rifle with five or six chambers in preference to this, with only one. Still, Mr. Leetch's rifle has the advantage of using the Government ammunition, and on that account it will be valuable to sportsmen on distant stations.

WESTLEY RICHARDS' NEW RIFLE.

A patent was taken out in 1858, by a celebrated gun-maker of Birmingham, for a breech-loading carbine, which,

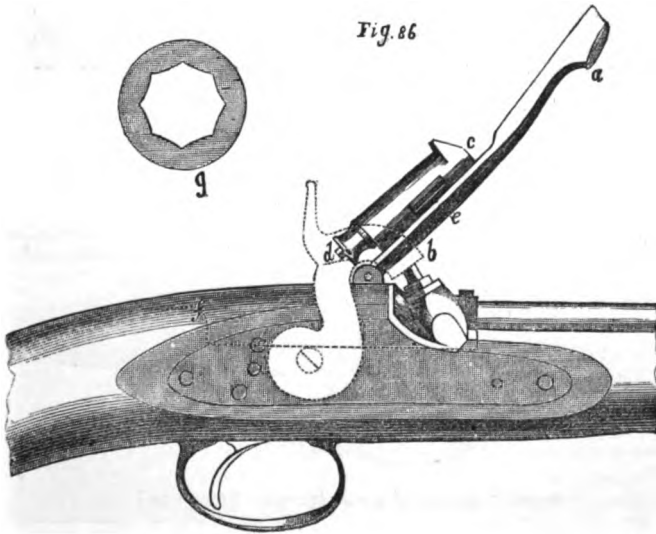

WESTLEY RICHARDS' NEW RIFLE, OPEN (HALF SIZE), AND SECTION OF THE BARREL (FULL SIZE).

as recently modified, has given great satisfaction to the Small Arms Committee, and for some purposes is likely to be useful

to the sportsman. It is extremely simple in its action, and can be loaded with the utmost ease; but it is open to the objection of escape at the breech, and on that account is rather to be avoided by the sportsman, excepting for special purposes—such as buffalo hunting, where easy loading on horseback is a great object. With regard to any credit which may accrue to the inventor, his rifle appears to me to be clearly a modification of Restell's (see fig. 84), and of the Comte de Chateauvillier's gun (see figs. 58 and 59).

This rifle is constructed as follows:—Fig. 86 represents the rifle with the breech open, ready for loading; all that is necessary for this purpose being to raise the lever *a b*, when the chamber *f* is exposed, and after pushing the cartridge forward through this into the barrel, the lever is depressed, the sliding plug *d* is driven forward by the shoulder *c* striking against *f*, and the breech is closed. When this is done, the parts occupy the position shown in fig. 87. It

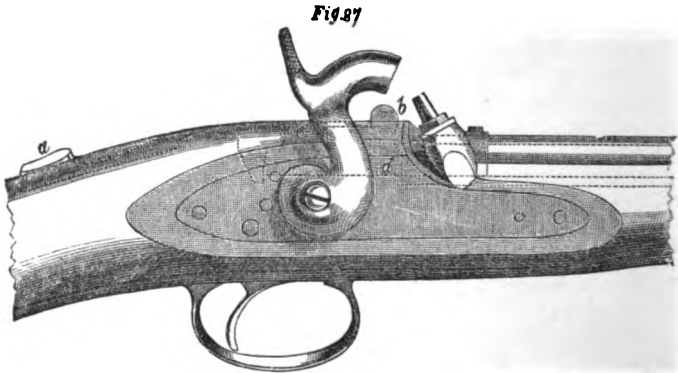

WESTLEY RICHARDS' RIFLE CLOSED. (HALF SIZE.)

will be seen, that by the form of the back of the chamber at *f* the plug cannot easily rise by the force of the explosion, being confined down partly by a spring at *b*, and partly by the undercutting of the plug at *f*. On a close examination of the sliding plug it will be seen that at

the lower and back part there is a projecting point, which drops into an opening in the chamber in which it lies. The object of this is to drive the plug back close to the undercut surface, so as to prevent the lever from rising on the explosion of the powder. The plan is most ingenious, and renders the action safe ; but it does not prevent escape, which can only be done by using a thick wad of greased felt at the back of the cartridge. If the rifle is discharged without this adjunct, the lever continues depressed in all cases until the ball has left the muzzle, because the pressure of the gas on the front end of the sliding plug, drives it back under the undercutting ; but the moment the pressure is taken off, if the lever is fitted closely to the stock, the compressed gas beneath it has a tendency to drive it up, and every now and then it will rise. Owing to the shortness of the loading chamber, the cartridge must have a flexible neck, and for this reason the paper is very stout, and is used double, or indeed for a portion of the circle it is often treble. Hence there is some difficulty in effecting its penetration by the explosion of the cap, and Mr. Westley Richards uses the old-fashioned black caps made of antimony, as described at page 207. The whole cartridge is three inches long, and greased with some composition, the nature of which I do not know. The wad is of felt saturated with the same grease, and about three-sixteenths of an inch thick. The paper of the cartridge is continued over the ball for the whole length of the cylinder, which is nearly one inch. The ball is one inch and a quarter long, being of the same weight and shape as Whitworth's (530 grains), but the diameter being larger, to suit the chamber, there is necessarily a diminution of length. The bore of this rifle is $\cdot 451$ of an inch, and the rifling is said to be Whitworth's ; but there is a considerable difference, as may be seen by comparing that used by Westley Richards (fig. 86 *g*) with Mr. Whitworth's bore (fig. 75* *a*). In the former there are eight convex sides, with sharp angles, while in the latter there are six straight sides with the angles rounded. The result is, that eight concave grooves are or ought to be cut on the surface of the ball ; but owing to the double thickness of paper covering it, they are very imperfectly marked, according to Lord

Vernon's experiments, to which I have referred in alluding to Henry's rifle.

The success of these rifles at the Wimbledon Meeting of 1860 when they distanced all other breech-loaders, and in several instances beat the Whitworth, has given them a great reputation, and they undoubtedly enjoy a higher position than any other breech-loading rifle. Since that time, however, they have never done anything worthy of note in public, and at Southport they stood no chance either with the Whitworth rifle, or that made by Mr. Turner, of Birmingham. My own belief is, that though a long range may be obtained with them, precision cannot be secured, on account of the thick felt wad which lies in front of the ball being left behind on each successive discharge. I have been told on good authority that at Wimbledon this was each time removed before shooting, but whether this was really the case or not I am not prepared to say. Indeed, the shooting was not such as to lead one to believe it, for the score made was very far below the average of either the Whitworth or Mr. Turner's rifles, and was about the same as that made by those of Mr. Westley Richards at Southport. I am not fond of paper round the balls of muzzle-loaders, but a quantity of it on those used for breech-loaders is very objectionable, because the edge comes in contact with the shoulder of the chamber, and reeves up more or less according to the degree of adhesion which exists between it and the lead. In Mr. Westley Richards' rifle, the chamber is bored out to a considerable extent, varying from $\cdot 480$ to $\cdot 484$, and extending for nearly five inches from the breech plug, or about an inch beyond the cartridge. This great length and size is necessary on account of the amount of paper which is often left behind ; but it also must, I imagine, be prejudicial to good shooting. For these reasons, although the rifle may be found to be useful for cavalry purposes, it is not, in my opinion, suited for sporting, since it has the serious disadvantages of being liable to miss fire, of being deficient in accuracy, especially at short distances, and of recoiling so severely, as sometimes to occasion great inconvenience.

The cartridge is made by folding a strong but thin paper,

sometimes coloured blue, two and a half times round the ball, extending up the whole length of the cylinder, and securing it to the lead by pressure alone. The seam is spiral, and is closed by gum ; after which it is filled with powder, Curtis and Harvey's No. 6, the charge varying from 70 to 80 grains. The paper is then cut off to the length of the powder, and a cap is put on composed of more paper of the same kind, to which is attached a wad of woolly material, felted in a peculiar way, about a quarter of an inch thick, and rather larger than the bore of the chamber. The whole is then greased by some fatty matter, the nature of which I do not know, and the cartridges are packed in tens, ready for use. The powder keeps perfectly dry, and I have used these cartridges after lying exposed to the air for months ; they are so strongly made that they will bear any amount of fair usage.

LANCASTER'S BREECH-LOADING RIFLES.

Mr. Lancaster, with his usual ingenuity, has produced two breech-loading rifles. One of these is a purely military carbine, having the cock below the barrel and in front of the trigger, so that it will be unnecessary to allude to it here. The other is a double sporting rifle, exactly similar in its breech and locks to the shot-gun described at page 280, but rifled on the oval spiral method partially alluded to among the muzzle-loaders at page 324. As, however, this kind of sporting rifle has obtained a considerable reputation, it will be necessary to describe it here more minutely. I have before remarked, that the locks and the method of opening and closing the breech are exactly as given at page 280, the cartridges also being made in the same way. The barrels are of course rifled, and this is done on the oval spiral method adopted by Mr. Lancaster in all cases. The twist is one in 32 inches, which is the length of the barrels, and the bore $\cdot 498$. The variation of the bore from a perfect circle is only $\cdot 01$ in half an inch, being scarcely to be detected by the eye without the aid of some mechanical appliance—such as a gauge. This method of rifling has been compared to a rifle with two grooves cut very shallow, and with the angles ground down. It is alleged by the advocates of the prin-

ciple that friction is greatly diminished—to such an extent, they say, as to be scarcely greater than in an ordinary smooth bore, while the opponents declare that, instead of this, it is increased, the ball being jammed in the barrel as it is converted from the circular form which it has before firing to the oval section of the barrel. My own belief is that the friction is very slight, and that when sufficient rotation is given this rifling answers remarkably well, but that in a certain proportion of shots the ball “strips” and goes nearly straight through the barrel, and not having sufficient spin is immediately upset. The bullet now adopted by Lancaster is the solid Pritchett, with the cylindrical portion covered with thin greased paper. The length of the ball is $2\frac{1}{2}$ diameters, and the windage one five-thousandth.

In loading the cartridge, as the ball is circular in its diameter, it may be inserted without regard to the bore—that is to say, in any position. If the fit is carefully adjusted, I believe that the ball will rarely “strip;” but without extreme circumspection the accident is almost sure to arise. Each ball must be passed through a gauge called a “swedge,” and with this precaution the rifle will be found to be extremely useful; but from the high price charged by Mr. Lancaster (60 to 80 guineas) it is not within the reach of every sportsman.

NEEDHAM'S RIFLE.

This rifle is capable of being made either with two barrels or one, the original principle, with a slight alteration, being adopted throughout the Prussian army. In either case the lock, stock, and breech are exactly similar to the shot gun described at page 271. The barrel, of course, varies in being rifled, and the cartridge has a ring instead of a perfect wad to support the cap, so as not to interfere with the progress of the bullet as it lies before it. The barrels are usually 2 ft. 9 in. in length, with three-quarters of a turn in three feet; bore, 30. The rifling consists of five shallow grooves without sharp angles, and very similar to Mr. Boucher's plan, described at page 326. In smaller bores the grooves are only three or four, according to the diameter. Mr. Needham's opinion is that the nature of the grooving is not of much

importance in breech-loaders so long as the ball is made of the same size as the barrel at the bottom of the grooves. I have never seen these rifles tried, so I cannot give any opinion as to their merits; but, excepting in the perforated wad or ring before the ball, there is little to alter their shooting from that of any ordinary breech-loader.

THE LEFAUCHEAUX RIFLE.

Almost any form of rifling may be adapted to a pair of barrels constructed with Lefauchaux's breech, but those which I have seen tried have been of the Enfield bore and grooves, made by Reilly, and they have performed well at 100 and 200 yards. The cartridge is similar in principle, but usually of smaller diameter, as there are few who would now use a rifle with a 12 or 16 bore—the former, on the usual allowance of $2\frac{1}{2}$ diameters, carrying a 3 oz. ball, and the latter one weighing $2\frac{1}{4}$ ounces. The weight of these rifles with Enfield barrels is about 9 lbs.

Cartridges to suit the Enfield bore, numbered 24, are made by the French cartridge-makers, and may be obtained of any gunmaker by special order.

BASTIN'S RIFLE.

As this rifle differs from Lefauchaux's only in the mode of closing the breech, as described at page 264, it is unnecessary to allude to it further here. Although there is no hinge, and the barrels slide, I believe the joint is not so strong *when the breech is closed* as that of the Lefauchaux pattern.

GILBERT SMITH'S AMERICAN RIFLE.

This new rifle has recently been brought over to this country for trial before the Small Arms Committee, and is patented both here and in France, as well as in America. It is so constructed that the joint is broken in the middle of the chamber for the cartridge, and it is hoped by the inventor that this will prevent all escape; while by simply perforating the centre of the wad, which closes the base of the cartridge,

and carrying the tube leading from the nipple down to the corresponding part in the back of the chamber, an ordinary cap is sufficient. Fig. 88 shows a section of the chamber

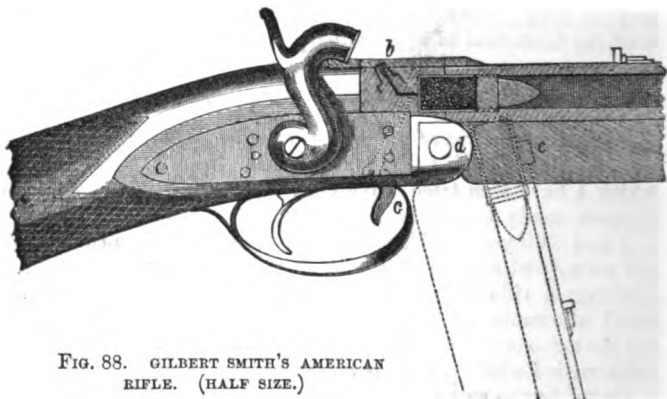

FIG. 88. GILBERT SMITH'S AMERICAN RIFLE. (HALF SIZE.)

with the cartridge inserted and the breech closed by the catch *b*, which is raised by the lever *c* moving the rod marked in dotted lines; *d* is a strong hinge between the stock and barrel, and on pressing the lever *c*, the catch *b* is lifted from the square block *e* when the barrel falls, as represented in dotted lines, leaving, after the discharge, the empty cartridge-case with its base adhering slightly to the posterior half of the chamber. It is asserted by the promoters that these cases can be used a dozen times, or more, but never having seen either them or the rifle tried, I can give no opinion upon them. It appears to me that for sporting purposes it possesses no advantage over the Le-faucheaux pattern; but for military use, the ordinary cap is a *sine qua non*.

The cartridge is made of a simple cylinder of indian-rubber, with a base of cardboard; and as the former material readily bends, it allows the edge of the posterior half to give way on bringing up the barrel after inserting the other moiety in the chamber.

THE FIELD RIFLE.

Inventors are seldom capable of judging with fairness of the plans which they have devised, and probably I can lay no claim to be considered an exception to this rule. In alluding to this rifle, I shall therefore avoid giving any opinion on its merits, and shall merely describe the objects which I have had in view, leaving my readers to judge for themselves whether they have been accomplished.

The intention of loading at the breech is to give increased quickness in effecting it, and to enable the shooter to charge his rifle in whatever position he may be. In deer-stalking, for instance, the raising of the arm for ramming down a ball may be sufficient to give an alarm; and on horseback it is by no means easy to use the ramrod at all. Whatever plan is adopted should, therefore, allow of easy loading in any position. Joined to this, there should be a perfect closure of the breech; an absence of any impediment to accurate shooting left in front of the ball; and in my opinion the ball should in the greater part of its length be placed within the lands, and not in a chamber behind them. The thinner the paper covering the powder, the more certain is the explosion by the cap, and on that account a single layer, provided the loading is easily effected, is to be preferred to double or treble paper. Impressed with the importance of these objects, it occurred to me that the ordinary stopcock, which is in use for confining steam, water, &c., under very high pressure, might be made available, if the sulphuret of potassium, which is the foul deposit left on the explosion of gunpowder, could be kept from causing it to "set." On trying the experiment I found that simply by attaching a wad composed of wax, soft soap, and tallow, to the back of the cartridge, this could be ensured, and as this greasy compound is that which is ordinarily used for the lubrication of rifles, the wad would not only serve this purpose, but as it is carried before the ball on each discharge after the first, it lubricates the whole barrel without any risk of jamming the ball on one side, as happens with felt. In this way the stopcock is kept constantly greased, inasmuch as the force of the explosion

drives a small quantity of the wad into the space between the cylinder and its case, and as this works out at the sides more enters from the front. The sole difficulty lies in making the wad adhere firmly to the paper of the cartridge, and in small bores this is not easily overcome, but in the Enfield there is no trouble whatever. But the question arose—How is the cartridge to be pushed forward to its proper place and

Fig. 88*



FIELD RIFLE CLOSED.

no further? Here lies the essence of the invention, in accomplishing the task by means of a plunger, which, when it has

Fig. 88**

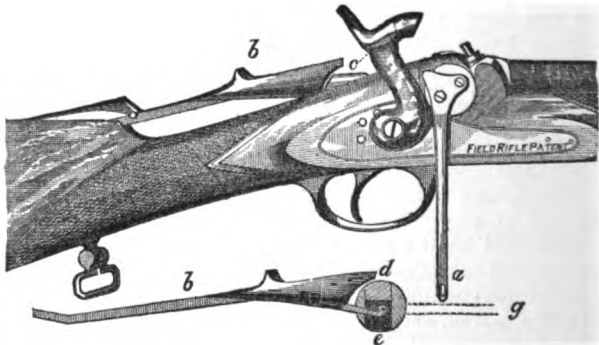

THE FIELD RIFLE OPEN, WITH THE PLUNGER AND CYLINDER SHOWN SEPARATELY.

carried the cartridge far enough, that is, just so as to be clear of the cylinder, being fixed on a point exactly in the centre, is allowed to revolve with it. This will be better understood by referring to the engravings, in which the first represents the rifle with the breech closed, and in the position which it assumes when just fired. At this time the plunger and cylinder are firmly locked, as indicated in the second engraving, in which *d e* marks the revolving part of the plunger, *b* the sliding part, and *g* the lever itself. By depressing this lever a quarter of a circle, as shown at *a*, the bore of the cylinder is brought into a line with that of the barrel, and the plunger is liberated, so that it may readily be drawn back, exposing the loading chamber as at *b c*. At the same time the hammer is raised to half-cock by a slight projection on the lever, which acts upon its lower part. Then dropping in the cartridge, it is pushed forward to its proper place by the plunger, the lever is raised to its original level, and as soon as a cap is placed on the nipple the rifle is ready for firing. It will be readily understood, that though there are two actions instead of one, as in Mr. Westley Richards' rifle, yet the half-cocking being effected at the same time, does away with one of these additional motions, while the increased facility in loading meets the other, and practically it can be loaded and fired quite as rapidly, if not more so.

From the large mass of metal which forms the breech, and from the entire absence of escape, it is asserted to form a most perfect action for the purpose for which it is intended, and I have obtained better results at all ranges from it than from any other breech-loader which I have tried.

The cartridge which I have used is made by fixing a thin paper case to the *inside* of the hollow cone at the base of the ball, by means of an adhesive compound made of resin five parts, bees-wax one part, melted together, and used hot. Thus there is no paper left on the ball to interfere with its taking the rifling, and with a wad of greasy matter composed of wax two parts, tallow and soft-soap each one part, in addition to some spermaceti ointment applied hot to the paper itself, the lubrication is kept up so perfectly that no leading ever takes place. The ball is made exactly like that used by Mr. Whitworth, as described at page 330, for three-

fourths of its length, but at the basal fourth, it is enlarged about 20 thousandths of an inch, and thus while the greater part of it can enter the lands, there is a shoulder which prevents the base from dropping into them. Like all those in which the cap has to perforate paper, this should be of more than ordinary power, and those of Mr. Westley Richards' make, described at page 207, will answer well.

WILSON'S RIFLE.

A rifle under this name has been extensively advertised during the last few months, but with little claim to originality, or to any advantages over its rivals. Its plan consists in a plunger, which is drawn back and driven forward in the same position as Restell's (see Fig. 84); but instead of this being done by a cam moved by a lever as in that rifle, it is effected by the unaided power of the finger and thumb. A slide working in a slot cut in this plunger is the sole means of taking the recoil, and this also being drawn out by the finger and thumb, if there is the slightest tendency to clog, there is no power to overcome the resistance. Consequently, it is not surprising that, after a very few rounds, the action of this rifle is found to stick.

MACKENZIE AND WENTWORTH'S RIFLE.

One of the most ingenious inventions of modern days is the rifle patented under the above name, which, like Leetch's,

Fig. 88†

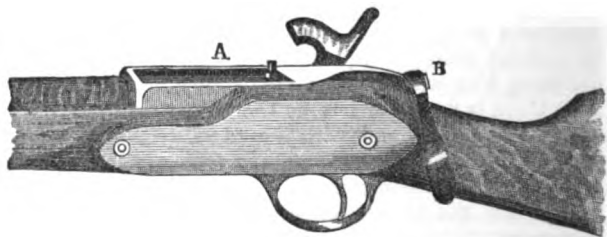

MACKENZIE AND WENTWORTH'S RIFLE CLOSED.

is intended to take the Government ammunition. It consists in a chamber, capable of holding the charge, fixed to the barrel by means of two side straps. This chamber, when ready for firing, lies down in the position shown in the first cut, when the only apparent difference from the common rifle consists in the slot A in which it lies, and the lever B which is turned on the left side of the handle. On turning this lever to the right as far as it will go, the chamber is first brought back from the face of the barrel by means of a double screw, and then its fore end is tilted up for loading, as shown in the second cut at A, the lever B being now on

Fig. 88††

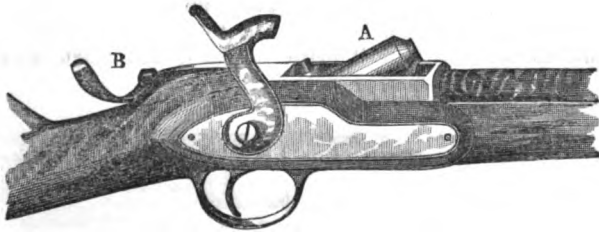

MACKENZIE AND WENTWORTH'S RIFLE OPEN.

the right of the handle. By the drawing back of the chamber, a short cone ground into the barrel is liberated from it, and in this way a more effective means than usual is provided for the prevention of the escape of gas. In theory, therefore, the action is beautiful in the extreme, but it is open to two objections. In the first place, a very little dust (either of sand or of the powder used in loading) will prevent the action of the delicate machinery used to effect the opening and closing of the breech; and in the second, the slot in which the chamber lies being open above is liable to collect the rain, and let it drip down to the screw and cam, which it would rust, and seriously affect. While, therefore, I have the highest admiration of the ingenuity displayed in perfecting this invention, I believe it to be wholly inapplicable to actual use, either for sporting purposes or war.

RIGBY'S NEEDLE PEA RIFLE.

For rook and rabbit shooting, as well as for other sporting purposes, a breech-loading rifle of a bore no larger than a pea (that is of about 100 gauge) is very much wanted. For some years past a barrel, jointed on the plan of the Lefauchaux gun, but used with a needle and needle cartridge, has been generally adopted. Messrs. Rigby, of Dublin, have lately improved upon this, by an arrangement which enables them to extract the cartridge-case after each discharge, instead of leaving it to be pushed forward in front of each succeeding ball. The plan they adopt is as follows:—The general appearance is similar to that I have already alluded to, but the false breech which is screwed up against the open mouth of the barrel is hollowed out to receive the cartridge, and undercut so that it grips it firmly, and when drawn

Fig. 88†



RIGBY'S NEEDLE PEA RIFLE AND CARTRIDGE.

back, by reversing the action of the screw by a half-turn of the lever *a*, it brings the case back again out of the chamber, and on depressing the barrel it drops out. At the same time a cam acts on the needle-holder *c*, and drives it as well as the hammer *e* back to half-cock. The second cut shows the state of things when this has taken place, and thus there is no time lost either in extracting the case with the fingers,

or in pushing it forward into the barrel, by which latter operation also the shooting is seriously injured. In this

Fig. 88††



engraving the several parts are indicated by the same letters, and in addition *b* marks the thumb-screw which fixes the needle-holder, and *d* the barrel. There is, however, one slight objection to the plan, though by no means a serious one. If the sportsman wishes to extract his charge without firing it, he will find that the cartridge being loaded will not readily give way and allow the barrel to be depressed, but that an amount of force must be employed to break it, which would alarm many men if they have not previously been made aware of its necessity. A section of the cartridge loaded is shown also, so as to give an idea of the shape of the ball. By the plan adopted in attaching the needle it may very readily be removed and cleaned, and thus one main objection to the use of the needle rifle is entirely done away with. The Messrs. Rigby claim for their invention the following advantage, and as far as I can judge from a partial trial of it they are fairly entitled to it. These are:—
1st. The act of opening the breech to reload draws back the exploded cartridge case, and the dropping of the barrel *throws it out*. This is effected by the undercutting of the

breech screw. 2nd. The cartridge is enclosed partly in the breech and partly in the barrel, whereby the joint is thrown on the *side* of the cartridge in place of the *corner*, and escape of gas is prevented. This is the first and most necessary step towards obtaining uniform shooting. 3rd. The breech is so constructed as to half-cock the lock on being turned round for the purpose of opening the gun, and thus the breakage of the needles is rendered impossible. 4th. The needle, striker, and pin, are immediately removable for cleaning, replacing a worn needle, &c., by withdrawing the latter, which has a finger-piece for the purpose. The screwed breech can also be taken out in a few seconds without the use of a turnscrew or any tools; and when desirable, the lever which turns it can be removed, and the gun rendered incapable of being used *in the absence of the owner*. 5th. The barrel is jointed to the stock in the same manner as the French breech-loading guns, so that they may be at once separated to pack in a portmanteau or case. 6th. The barrel has a case-hardened breech-bed screwed on, which prevents the chamber or joint wearing or rusting.

A *slight modification of the Lefauchaux* plan, in which copper cases are adopted instead of those made of paper, is most excellent for this purpose. These were first introduced for the purpose of rapidly reloading revolving pistols, but they answer so well for small bores, that they are now applied to pea rifles with great advantage. A double pea rifle intended to be used with this ammunition of 80 or 100 bore may be purchased for 10*l.*; but of course the workmanship is not first-rate, though sufficiently good to be safe and useful. With a small charge of powder there is no danger of these copper capsules sticking, but with a large one they cannot easily be extracted, as from the metal not being elastic they expand and do not afterwards collapse. For shooting rabbits, rooks, and sea-fowl, and other similar purposes, they are admirably adapted; and as the locking machinery need not be very strong their weight may be kept low. A double rifle on this construction may be made to weigh only five pounds, and thus a handy little tool for general purposes may be placed at the service of the sportsman who is content with small game.

SHARPE'S AMERICAN RIFLE.

About five years ago some thousands of these rifles were ordered for the use of our cavalry, having been examined *in-doors* by the authorities of the day, and considered to be extremely likely to be useful. But in real service it was found that the recoil was so enormous, and that the self-priming principle was so little to be relied on that they are now entirely given up. The principle consists in the adaptation between the open breech and the false breech of a strong plug of iron, which is lowered by a powerful lever. This, after introducing the cartridge, is raised by the same means, and not only closes the breech but cuts off the end of the thin cartridge paper. The priming is effected by a very ingenious action, which throws a little disk of copper between the nipple and hammer during the descent of the latter and after pulling the trigger. This plan acts very well when free from the action of the wind, but if it is at all submitted to this agent, the disk is blown away and the consequence is a miss-fire. Independently of this defect, however, the amount of recoil, and the noise in the ears caused by the escape are so great as to ensure its rejection by the sportsman.

REVOLVING RIFLES AND PISTOLS.

A very old invention, specimens of which have been stored in several collections of implements of war, was, some years ago, revived and remodelled by Colonel Colt in America, and has now become universal in the form of "the revolver." The patent granted to Colonel Colt covers only the exact mechanism by which the principle is applied by him, and numerous rivals have since appeared in this country, among whom may be mentioned—Tranter, Adams, Harding, Daw, and some others of lesser note. There is very little difference among these, all using a single barrel, with a block of iron revolving behind this, bored with five or six chambers, each of which is successively brought in a continuous line with it. There is also only one lock, but there is a nipple corresponding with each chamber; and thus, as the chambers revolve, they are inserted between the hammer behind and the open barrel in

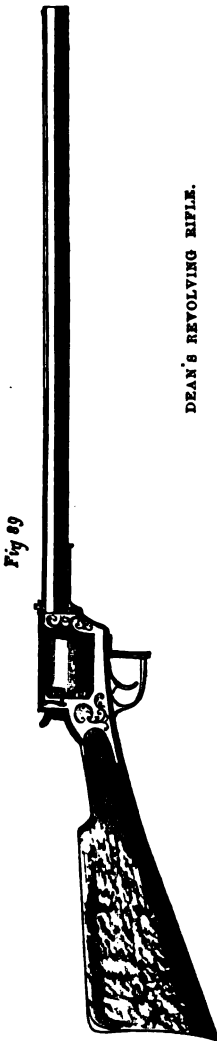

DEAN'S REVOLVING RIFLE.

front. The half-cocking of the hammer causes the chambers to revolve to such an extent as to place the next chamber in the right place, and there it remains till the hammer is let down and brought up again to half-cock. Some of the plans are carried out so that there must be a cocking with the thumb in every case; others, again, are made to revolve, cocked, and discharged by the action of the finger on the trigger; while a third set may be used in either way at discretion. It is manifest that where great rapidity is required, as in the defence of one man against several, a larger number of shots may be fired in a given time by the second mode than where the thumb has to be used to raise the hammer, but from the stress upon the finger the aim is not so good; and if a revolver is used for sporting purposes it should not, therefore, be made on this plan.

The objections to the revolver as a sporting rifle are, that the recoil and escape are both extremely annoying to the shooter, while the accuracy of aim is not at all to be compared with a muzzle-loader, or with the best kinds of breech-loaders. The cause of this inferiority is to be looked for partly in the great escape which takes place, and which weakens the force of the explosion before the ball reaches the muzzle, and partly in the imperfect adaptation to the barrel of each chamber in succession. The revolving *Pistol* performs much better in proportion to its length than the *Rifle*, because

in it the force of the explosion lasts long enough (in spite of the escape) to carry the ball to the muzzle. A great objection to the revolver for sporting purposes is also to be found in the necessity for a small bore, a large one being forbidden from a fear of the breech giving way. Fig. 90, shows the chambers and action of Mr. Dean's lock, as used in his revolver, but the rifling of Colt's is far superior to any which I have seen, and their performance at the target is I believe proportionately good.

Fig 90

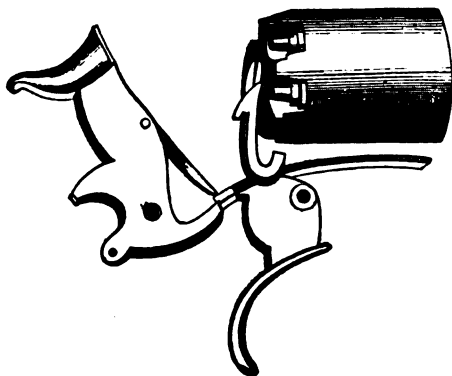

LOCK, CYLINDER, AND TRIGGER OF DEAN'S REVOLVER. (HALF SIZE.)

*Of the various principles upon which revolving rifles and pistols are made, I believe there is none equal to the Dean-Harding, lately brought out by Mr. Dean, of King William-street, City, if efficiency and rapidity of discharge for five or six shots only is regarded as the *ne plus ultra*. But when rapid loading of the chambers is considered a desideratum, the use of the copper capsules on the principle of the Lefauchaux cartridge, as already alluded to under the head of the pea rifle, is a great improvement.*

CHAPTER IV.

THE ACCESSORIES OF THE RIFLE.

BULLET MOULDS—CASTING BULLETS—SWEDGING MACHINE—PATCHES—
CARTRIDGES—SIGHT GUARDS—RAMRODS—PLAIN AND TELESCOPE SIGHTS
—RIFLE POWDER—FLASK—RESTS.

BULLET MOULDS.

Bullet moulds are all constructed of steel or brass, in two portions, which open like a pair of pincers, and sometimes with a third, called a "plunger," which leaves the hollow at the base. The Government bullets are made by compression, but the expense of the machine puts it out of the power of private individuals. Beyond the elementary principle of casting the bullet in this hinged mould, there are several variations—as, for instance, in the position of the "run hole," through which the lead is poured. This may be, 1st, at the point of the bullet; 2nd, in the hollow at the base; 3rd, on the side; 4th, on the edge of the hollow. Again, the form of the cutter varies—being in the old spherical bullet mould placed in the handles, and requiring a second operation; while in many modern moulds it cuts off the neck as the mould is opened. The following remarks by "A Welshman," who is a high practical authority on this subject, are extracted from the *Field*.

"It is well known that bullets made by compression, like the service ones, are superior to any that can be produced by casting, on account of their being more uniform in size and weight, smoother on the surface, and free from internal air-holes; but bullets thus made are not at present to be obtained by volunteers (unless the Government should permit them to purchase from their stores); and they must therefore content themselves with such as they can get, or cast for themselves. An uniform bore and size of bullet being universally adopted, it will become a question whether it would not pay some one, as a speculation, to procure self-acting

machines, similar to those at work in Woolwich Arsenal, the invention of Mr. Anderson, chief engineer there, and with them supply the demand which will be general throughout the country, so soon as the volunteer corps have obtained their arms. However, this is not as yet done, and existing circumstances alone are those that have to be dealt with.

“So long as the spherical form of bullet was used, the moulds for casting them were very simple, the cheeks being made to open, and the run-hole being placed at their join. Solid bullets of any form were equally easy to run, the hole being usually placed at the centre of their base. The moulds used for running solid conical or conoidal bullets, the bases of which were not rounded, were sometimes made solid; but it is difficult to cast a good bullet in a solid mould, on account of there being no escape for the air. When, however, the Minié and other hollow-based bullets were introduced, the moulds became of necessity much more complicated, the addition of a “plunger” to form the hollow in the bullet becoming indispensable.

“In the moulds first introduced for making the Minié bullet, the metal plunger, which was detached, was usually fitted on to a wooden handle, and placed in the moulds at the open end or base; and whilst the bullet was being run the handle rested on a board, or table to keep the plunger in its place. It was then withdrawn, and the bullet dropped out of the mould by opening the cheeks. The lead was run from the point, and the neck removed when the bullet was cool, by means of a burr-cutter.

“Several improvements were made on these moulds, one of which united the burr-cutter to the mould, in the form of a traversing steel plate, attached to its upper surface by a pin, and in which a hole was counter-sunk, directly above the apex of the bullet, and the lead run through it. When the mould was full, this plate was struck and made to traverse, and removed the neck from the bullet, before it left the mould. Another improvement was a mode of attaching the plunger to the lower surface of the mould, in such a manner that it formed part of the latter, and was always adjusted in its place by the same movement that opened and closed the cheeks of the mould. By these modifications the hollow-base bullet is as easily cut as the solid one

“ Numerous patterns of bullet-moulds are now in use, and the point from which the bullet is run varies—the usual places at which the run-hole is placed being, 1st, the point; 2nd, the side; 3rd, the ridge between the hollow and exterior of base; and 4th, the hollow in the base.

“ However well a bullet is cast, it is always subject to certain defects—which are, an irregular surface at the spot whence the neck has been removed, and generally, or always, an air-hole, which is usually situated just below the place at which the bullet has been run. The great object to be attained is to place these defective parts in such a position as to exert the least possible influence on the motion of the bullet when passing through the air. The first defect—irregularity of surface—injurious to the correct flight of the bullet, by the air acting on it, and thus altering its direction; and the latter—internal air-holes—by disturbing the balance of the bullet round its axis of rotation, and thus tending to cause a certain degree of irregularity in its motion; but if this air-hole be situated on the bullet's axis it will not affect its balance on that axis, and the further it may be from it the more its disturbing influence must be felt.

“ It is clear, therefore, that in order to reduce the influence of the two unavoidable defects pointed out to a minimum, the bullet should be run from the centre of the hollow in the base, as the “burr” left is then in a position where the air cannot act on it, and the air-hole is, in all probability, on the axis of rotation. The only moulds that I am aware of that fulfil the conditions required are of a pattern invented and patented by Mr. Charles Lancaster, and are most ingenious in their construction. The plunger which forms the hollow in the base of the bullet is cupped out to the shape of a small basin, in which there is a hole slightly eccentric, or just off the centre. To this plunger a small handle is attached, a movement of which in either direction, after the lead has been poured into the mould, detaches the neck and leaves the bullet perfect. It is true that, in order to cut off the neck by a circular movement of the plunger, the run-hole cannot be precisely over the axis of the bullet, but it is so nearly so as to amount practically to the same thing.

“Running from the point is, in my opinion, better than from the side or edge of the base, because the bullet is usually cast more uniform on surface, and so slight an unevenness at the point as is left where the neck is carefully removed is not sufficiently acted upon to influence its flight; but no bullet having an open air-hole at the point should be used. Running at the side is objectionable on account of the difficulty of removing the burr so accurately as to prevent its rendering the bullet hard to ram down, should the point at which it was run happen to come opposite to one of the lands in loading.

“Some moulds are made in which bullets of various lengths may be cast by the adjustment of the plunger, which is fitted on a screw passing through a plate tapped to receive it, and secured to the lower part of one cheek of the mould. On the screw a nut works, by which it is clamped in any position. In these moulds the run-hole is generally at the point, but might be placed at the side if desired. They would be useful to such persons as propose using the Pritchett bullet, as slightly increased length to that formerly adopted in the service, since by altering the adjustment various lengths might be cast and experimented with, and that which yielded the best results, with the particular pattern of rifle adopted, determined on.

“Mr. Lancaster's is the best description of mould that has yet appeared, the only objection to it being its expense; but as it would not be necessary for a volunteer corps to have more than one or two to supply its members from, the question of cost is not a material one.

“WELSHMAN.”

Agreeing as I do with every syllable of the contents of this letter, I need make no further remarks upon the subject.

CASTING BULLETS.

Having the mould ready, the lead should be melted to the proper heat, which experience alone can indicate, in an iron ladle with a fine lip to it, and all impurities being skimmed off, it should be carefully poured into the mould, holding the

lip close to the "run hole," so as to avoid any chance for a bubble or air-hole. In the simple form of mould the two cheeks must be separated, when the bullet readily comes out; but when there is a plunger it must be raised according to the particular form of which it is made. When the bullets are cool they still require to be trimmed, and if conical, and for accurate shooting, they should pass through a die or "swedge."

SWEDGING.

Messrs. Greenfield and Son, of 10, Broad-street, Golden-square, London, who are the chief bullet-mould makers, and who have constructed the bullet stamping machines for Government, have lately advertised a very simple bullet-correcting machine, applicable to the Pritchett ball. Its form is as here represented, and its intention is to ensure correctness in

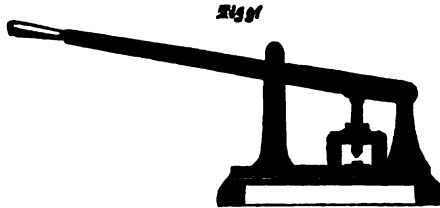

GREENFIELD'S SWEDGE.

the size of all kinds of cast bullets, whereby the inconvenience experienced with tight fitting balls is entirely removed, and greater correctness of shooting produced. The directions for use are—Place the cast bullet in the mouth of the die, press down the handle which will force the bullet through; occasionally pass a slightly oiled feather into the die.

PATCHES.

Patches are made of paper, or of lawn, cambric, or very thin calico, all greased with spermaceti ointment. The intention is to facilitate the application of a lubricating

agent, and at the same time to prevent windage by filling up the space between the ball and the barrel. They are made of a circular form for spherical and short conical balls, and are placed over the mouth of the barrel with the greased side downwards, the ball being pushed down upon them. The common circular patches are not suitable to any bullet having much cylinder to it, as, if the patch is thick enough to give a good fit at the base of the bullet, the gathers formed by the edges round the shoulder render it very hard, if not impossible, to ram it down; and if allowance for this is made in the thickness of the material, or in windage, the base does not then fit close. For this reason circular patches are only applicable to round or conoidal projectiles. They may, however, be used by altering their form from that of a circle to that of a cross, the centre part of which is exactly the size of the base of the bullet. The readiest mode of getting at this shape is to cut the patches circular first; then lay on them a steel or tin pattern of the cross required, and cut out the angles with a sharp-pointed knife, or a stamp may be made to cut them out at one blow. However used, patches are troublesome, and render the loading slow, being difficult to separate and dirty to handle. Hence many good shots (among whom may be included Mr. Purdey and that high authority Mr. Boucher) dispense with patches altogether, and merely dip the base of the bullet in a composition of beeswax and tallow, as described at page 329, in an extract from one of Mr. Boucher's letters.

A correspondent of the *Field* ("F. J. J.," of Derby) has suggested a simple contrivance for keeping patches on the ball ready for use, whereby the act of loading in the field is considerably accelerated. He says: "The inconvenience is known to all rifle shooters of handling the patches and balls separately in the field, picking the former with difficulty out of the box, and adjusting them with the ball at the mouth of the rifle. To obviate this, I have had made a number of tin cylinders, the length of the ball or bullet (I use the Enfield), and just admitting the patch and bullet. One end of the cylinder is slightly trumpet-mouthed to ease the fitting in of the patch and bullet. Its appearance is as in

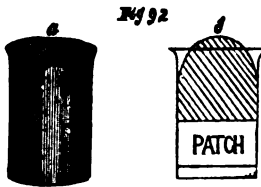

PATCH CYLINDER (SLIGHTLY REDUCED).

fig. 92 a. Preparing for the field at home, I load as many of the cylinders as may be desired, by placing the patches on the trumpet-mouth (using cruciform patches), and then pushing them down with the bullet into the cylinders. The bullets are pushed down till the flat end comes within one-eighth of an inch of the other end of the cylinder, leaving,

therefore, one-eighth of an inch of the dome-shaped end of the bullet protruding above the trumpet-mouth; this prevents the patch from being chafed out of place in the pocket, bag, or cartouche pouch. The appearance of the loaded cylinders is shown in section fig. 92 d. Loading is done thus:—Placing the cylinder on the mouth of the rifle, press down the dome end of the bullet, just entering the flat end into the barrel, and pluck off the cylinder, and return it empty into the pocket. A slight tap of the hand forces down the bullet and patch into the barrel, and the ramrod is then applied. I find this plan to answer perfectly.

“ F. J. J. (Derby). ”

CARTRIDGES.

Cartridges for rifle balls are made in various ways, as noticed under the head of each particular kind of rifle. Most sportsmen, in using the muzzle-loader, prefer to load from a powder-flask; but even then it is well to carry the bullet prepared either with a patch in a tin tube, as described by “ F. J. J.,” or enclosed in paper according to the following directions, which are those of a “ Welshman,” whose great experience has already been alluded to:—

“ It is not probable that, for ordinary practice, volunteers will go to the trouble of making up regular cartridges, but will generally prefer to load from a flask, and carry the bullets separate in a pouch. A good mode of preparing the bullet to be used in this way is to roll it in paper in the following manner:—

“ The paper is first cut into trapezium-shaped pieces, the depth of each piece exceeding the length of the cylinder on

the bullet by about half an inch, or rather less. The length of the long side should be just sufficient to fold twice round the bullet at its base, with half an inch to spare, and the angle which the inclined side makes with the long side about forty-five degrees. Supposing such a piece of paper to be lying before the person making up the bullet, with its square end towards him and its long side to his right, the bullet would be laid on the end nearest to him, with its point to the left and its shoulder exactly over the left edge, and rolled from him in the paper till the latter formed a close-fitting tube round its cylindrical part, and projecting about half an inch beyond its base. This hollow part is then 'choked' with a piece of strong string or catgut, till a neck is formed sitting close against the base of the bullet, when it is secured by two half-hitches and a thumb-hitch of thread or fine twine, and any edges of paper that are left trimmed off with a pair of scissors, so as not to project beyond the sides of the bullet. It is then dipped in grease, and ready for use. The bullet, thus prepared, is precisely as though it had been removed from a Government cartridge by cutting away the part above the shoulder of the projectile.

"Unless it is likely to be carried far in a pouch, the trouble of tying the neck may be avoided by merely twisting it after 'choking,' and pressing the end into the hollow base of the bullet with a round-headed former. It is rather difficult to obtain a paper of uniform texture—thin, and yet sufficiently tough to bear the 'choking' without tearing.

"The bullet thus prepared would, like the naked bullet, be used with a powder-flask. One of a pattern made by Messrs. Dixon, of Sheffield, in which the charger is detached from the body of the flask, is the best, because it gives the charge of powder more regularly than the ordinary pattern, and the safest, because, if the charge of powder should ignite in passing down the barrel, as in loading rifles does occasionally (but very rarely) happen, the explosion cannot ignite the remainder of the powder contained in the flask, and thus cause a serious accident.

"WELSHMAN."

In making cartridges for breech-loaders, my belief is, that none should have any paper on the outside of the ball itself. It is so much more easy to lubricate the barrels of breech-loading rifles than those of muzzle-loaders, that leading may always be prevented; and by attaching the paper containing the powder to the interior of the conical cavity, at the base of the ball, the exterior may be left quite naked. This is easily effected by making a mandril of the proper size, with a cone at the end, fitting *loosely* the corresponding cavity in the base. Then after gumming the paper round it, screw the end tightly round this cone, dip it in some melted resin and wax (5 parts to 1), and at once press it into the ball, to which it firmly adheres. The mandril is then withdrawn, and the case is ready for filling with powder. I am persuaded that this is far better than the usual mode of gumming, pasting, or gluing the paper on to the *outside* of the ball, which has first to get rid of this tough envelope, before the lead of which it is composed can take the grooves. I find that when cartridges made in this way are used, the shallowest groove is plainly marked on every ball; and even the fine lines, left by the cutter of the rifling machine are faithfully reproduced on the lead. As a consequence, very much more shallow grooves will answer the purpose with a naked ball than with one covered with paper; but of course, perfect lubrication is necessary to prevent leading, as well as the filling of the grooves with the residuum left by the gunpowder. I have carefully compared a number of different papered balls, which were shot, by Lord Vernon's direction, into water, with those naked ones which I have myself obtained in a similar way; and I find that there is no comparison between the sharpness of the grooves cut in each case. Even the angularly shaped lands of Henry's rifle, which showed the best results in Lord Vernon's experiment, made far less perfect lines on the lead, than are left by rounded lands on a naked ball; and therefore, I have no hesitation in recommending the adoption of the plan I have advised, wherever the lubrication is sufficiently perfect, to ensure that the grooves shall be left unclogged, which, I believe, can be accomplished in all breech-loaders, in which the cartridge is inserted from behind.

SIGHT GUARDS.

It is necessary, as far as possible, to protect the front sight from injury by striking against a wall, when the rifle is laid against it, as is so often done. For those intended solely for target practice, a guard is sometimes permanently fixed in the shape of a ring over the sight; but this does not answer well for sporting purposes. Captain Jaques has invented a very simple plan, which not only can be used as a guard, but

Fig. 92*

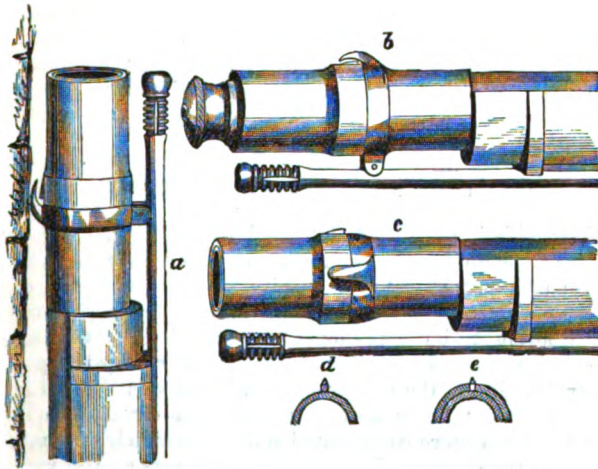

CAPTAIN JAQUES' SIGHT GUARD AND REGULATOR.

will also regulate the front sight, by showing only a portion of the cone. His sight guard and regulator is made to slip on over the military rifle, exactly like the bayonet socket, and then being turned in one direction, it covers and protects the sight, as shown at *a* and *b*; while, by reversing it, the sight is uncovered, ready for shooting, as at *c*. The section *d* shows the appearance of the front sight without the regulator, and *e* the extent of it, which is exposed when it is fixed.

RAMRODS.

Breech-loaders, as a matter of course, do not require a ramrod, but every kind of muzzle-loader must have one. In order to avoid bruising the point of the bullet in ramming it down, the head of the ramrod should be made hollow, *and this should fit the bullet exactly*, for if it is too shallow it will bruise the point of the ball, and if too deep the edge will cut some part of the cone, and thereby impede the flight. The rod itself should be either of metal or of very strong wood. An excellent plan is to make it of iron, and hollow, so that, however foul the barrel may be, the powder may be poured down through the ramrod, the head of which, while it fits the conical point of the ball, acts as a trumpet mouth for the powder. When thus made hollow, the metal ramrod is scarcely heavier than when made of wood.

PLAIN AND TELESCOPE SIGHTS.

Every rifle is, or ought to be, carefully sighted, and this can only be done after repeated trials. It is necessary to fix two sights: one near the muzzle, which does not rise or fall, and which may be either a simple pointed wedge, or what is called the "bead sight," but both should be arranged so that they may be moved towards either side by a slight blow. By this plan, any inclination of the trajectory to either side is allowed for, this front sight being moved in the same direction. The back sight is a more complicated affair, inasmuch as it must vary with the distance, for however well it acts at 100 yards, it will be useless at 200, and so on. Hence it is usual either to have a succession of flaps which turn down over each other, or to have one small frame to turn up and fall down on the barrel, and on this is a slide containing the sight, so fixed that it can be raised to the several elevations necessary for all the distances within the compass of the frame. A V-shaped sight is that best suited to sporting purposes, and the succession of flaps as shown in the two-grooved rifle at page 322 the most convenient for rapidly changing them according to the distance required. It takes some little time

and care to raise a slide exactly to the required height, but a flap is lifted in half a second.

The telescope sight is much used in America and Switzerland, but in this country it is not considered of any service in deer-stalking, a shot being seldom taken at more than 300 yards. It consists of a small tube fixed along the upper surface of the barrel in such a manner that it may be raised or depressed according to the distance, and containing lenses similar in construction to those of an ordinary telescope. For target practice, especially with short-sighted people, the plan is greatly to be recommended.

RIFLE-POWDER AND POWDER-FLASK.

The powder suited for shot-guns is not so well adapted for rifles, which require a kind that shall leave as little residuum as possible, and which will not burn too quickly. Hence rifle-powder can hardly be too coarse, provided it will pass into the base of the nipple, and as the caps for rifles are stronger than for the shot-gun, there is no necessity for its entering the nipple-tube itself. Curtis and Harvey have the reputation of making the best rifle-powder, their No. 6 being that generally adopted. But Lawrence's and Hall's, and indeed most of the various makes are nearly equally good, as far as I have been able to try them.

Powder-flasks for rifle shooting should be made with the charger of small diameter, especially if the tubular ramrod is adopted. The object of the small size is to admit of its passing into the muzzle, by which some little adhesion of the powder to its sides is prevented. In other respects there is no difference from the usual form. (See also p. 373.)

RESTS.

For target practice a wooden rest is generally adopted, but this is quite useless for sporting purposes. In deer-stalking, also, there are almost always rocks or similar projections, which serve as rests, but in shooting over a plain, there is sometimes nothing of the kind, and then a rest such as that introduced by Captain Conolly will be found of great service.

Here the ramrod is made to form a rest, as shown in the annexed engraving.

The rest is made by a swivel screwed on to the lower part of the upper band of the rifle (see fig. 93 *a*), the upper

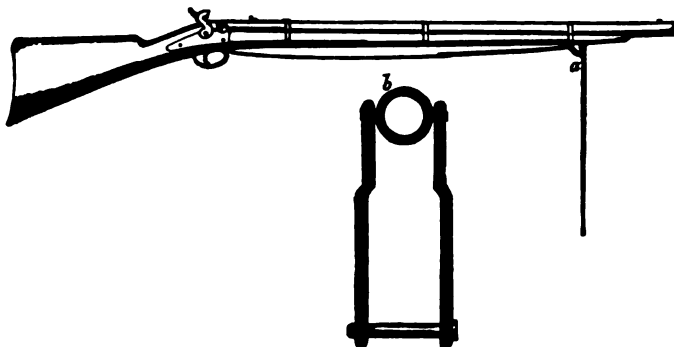

FIG. 93. CAPTAIN CONOLLY'S RIFLE REST.

swivel *b* being sufficiently large to give the ramrod full play, and being slightly ovalled, if necessary, to fit flush into the stock when not being used and the ramrod is returned. A small brass cup or socket, large enough to receive the head of the ramrod, is let into the stock above the band, the ramrod being then let fall through the swivel, and the head inserted into the cup, a most perfect rest is obtained.

It is by no means indispensable that the head of the ramrod should rest in the cup; it is nearly equally steady when butting against the slings or any other part of the stock—indeed, for a sportsman firing from the kneeling position, it is better to slope the ramrod forward, and let the head of it rest against the upper band. Captain Conolly merely inserts the *cup* into the stock, because, he says, a small incision must be made to receive the swivel *b* when not used. At the same time it steadies the ramrod more, and makes the rest more perfect when the cup is used.

CHAPTER V.

CHOICE OF A RIFLE FOR SPORTING PURPOSES.

REQUISITES FOR A SPORTING RIFLE—COMPARISON OF THREE PRINCIPAL KINDS—FINAL CHOICE.

THERE are three requisites for a sporting rifle—*first*, correctness of shooting at moderate ranges ; *secondly*, a definite weight, which should rarely exceed nine or ten pounds ; and *thirdly*, facility in loading. To these may be added strength of shooting and weight of ball. These several qualities are not equally shared by the muzzle and breech-loaders, and it will therefore be well to compare them together in reference to each other.

MUZZLE-LOADER.

BREACH-LOADER.

REVOLVER.

CORRECTNESS OF SHOOTING.

Nothing *beats* the muzzle-loader in this respect, but it is a doubtful question whether a good breech-loader is not *equal*.

Most breech-loaders are beaten by a good muzzle-loader easily at short range, and at long range almost all are.

Inferior to both the muzzle-loader and breech-loader in actual practice.

MODERATE WEIGHT.

There is a little advantage to the muzzle-loader in this respect.

FACILITY IN LOADING.

Beaten by the breech-loader. There is, however, a great difference in muzzle-loaders, some being very difficult to load, while others are just as easily managed.

Load far more easily as well as quickly than the muzzle-loader, and also than the revolver in a large number of rounds.

Six shots can be fired more quickly than with a breech-loader, but the latter will have the advantage if more than that number are to be fired.

MUZZLE-LOADER.

BREECH-LOADER.

REVOLVER.

STRENGTH OF SHOOTING.

Nothing shoots so strong as a muzzle-loader, not on the expansion principle, because there is no loss of power in cutting the grooves on the ball, and no windage whatever.

As the ball has to cut its way out there must be a loss of power; and consequently less strength of shooting, than with a ball such as Purdey's, which has nothing to do but to pass up the barrel.

The same remarks apply to revolvers as to breech-loaders, with the additional disadvantage of great loss of power by escape of gas.

WEIGHT OF BALL.

This may be increased to any extent in the muzzle-loader, and in any kind of breech-loader which is firmly secured at the breech.

See remarks on the muzzle-loader.

The weight of ball is necessarily small to keep down the size of the chambers, and to prevent accident at the junction of the barrel and chamber.

FINAL CHOICE OF RIFLE.

Of the various muzzle-loaders in use, I believe there is none better for sporting purposes than Purdey's two-grooved, with the winged ball. Here there is no unnecessary friction and no windage, and consequently a very low trajectory and a strong penetration. Mr. Boucher's I believe also to be a good plan, and having lately tried it for breech-loading rifles I can speak confidently of its merits. Lancaster's oval bore no doubt performs well occasionally, but from the tendency to strip, a shot is never to be depended on. Of the Enfield I think it may be said that it is a very useful one for common purposes, but that it is not capable of the high degree of perfection to which others may be carried—that is to say, if the weight of barrel allowed by the Government is strictly adhered to. This is far too light to allow of a heavier and longer ball than the regulation size, nor can a greater twist be adopted, so that for long range it must of necessity give way to the smaller bores. As far as the principle of grooving is concerned, I do not believe it to be faulty, and the only reason for its rejection is, that, from the want of strength in

the barrel, it cannot be used with a charge which will strain it more severely than that laid down by the regulations as proper for it. Henry's rifle shoots remarkably well, and is admirably adapted for the use of those sportsmen who take care of their own guns ; but the angles of the lands are so sharp, that an incautious use of the ramrod will soon raise a burr on them, and spoil the shooting. My own belief is, that for a muzzle-loading sporting rifle, the grooving is not of much importance, provided that it is well and regularly cut, and the barrel is just sufficiently eased at the muzzle, to let the ball out of it without a jerk. Any of the rounded grooves, whether Lancaster's, Whitworth's, or Boucher's, will give excellent results if they are kept clean, and the ball fits accurately ; but unless these essentials are attended to, the shooting will be inferior to that given by angular cuts, as in the Enfield, and especially if used with a winged ball, as in Purdey's and General Jacob's rifles. It is very difficult, in the muzzle-loader, to keep up the lubrication for many rounds, but for ten or a dozen a naked ball well greased will give the best results.

Among the breech-loading rifles in the market, there are only five which deserve the serious attention of the sportsman, namely, the Lefauchaux rifle, including all the varieties of this principle, Needham's and Rigby's needle rifles, Westley Richards', Prince's, and the Field rifle. Of these, the only one which has as yet been brought out usefully as a double barrel is the first-named, which, however, can seldom be made to shoot nearly as well as the muzzle-loader. Lately, I am told, that good results have been obtained by adopting the double grip action, described at page 262, but this I have never seen, and can only give my readers the benefit of the report. One chief reason of its failure has been, I am persuaded, that the ball shot with it has not been allowed to enter the lands, but has been used of the same bore as the enlarged chamber, throughout. This I hold in itself to be fatal to good shooting, but there is no reason for adhering to it in this kind of rifle. The paper cartridge is also probably too yielding to serve as the base for the elastic moving power to act from, but of this point I am not so confident as of the other. Needham's and other Needle rifles I have not suffi-

ciently tried, but I believe them to be open to the same objections as the Lefauchaux, with the addition (excepting Rigby's) of having to drive a stiff paper case before each ball. Westley Richards' rifle, as now sold, is objectionable for sporting purposes from the enormous recoil which it gives, occasioned partly, I believe, by the felt wad, and partly by the thick paper case left behind after every discharge, and pushed before each succeeding ball. The recoil in itself is prejudicial to good shooting, but the wad and paper are always liable to jam on one side of the ball and throw it out of its correct line; its small bore also prevents its adoption for large game. The rifle patented by Prince I have seen perform wonderfully well, and, as a single sporting rifle, I can see nothing to beat it when the cone is perfectly fitted to the false breech, which is rather difficult to accomplish, on account of the alteration of shape after case-hardening. With regard to the Field rifle, I have already mentioned that I shall avoid giving any opinion upon it.

Among those sportsmen who require rifles for large game, such as the elephant and tiger, there has lately been a controversy as to the relative advantages of the conical and spherical ball. That high authority, Mr. Baker, strongly advocates the latter, and objects to the cone in any shape; he asserts that, even with the semi-spherical end, it is liable to a grave disadvantage, which he thus defines:—"Upon striking a hard bone, all leaden bullets become disfigured more or less; thus their surface is altered. A conical bullet, with an equal charge of powder, may generally possess a greater degree of penetration than a spherical of the same bore; but I have seen many instances where the conical has disappointed me by striking full upon a shoulder-bone of a buffalo, and at once becoming so smashed that an immense surface of jagged lead was immediately substituted for the former cone, this surface being too great for the charge of powder that had propelled the mass when in conical form; the consequence was that it stopped at a very inferior rate of penetration. Common sense explains that an ounce and a half of lead beaten flat covers a greater surface than an ounce: thus the propelling power for the latter is insufficient for the former, and the conical ball, when once disfigured, becomes inferior in



THE STOAT IN ITS WINTER COAT (*Mustela Ermine*).



THE BEECH MARTEN (*Martes fagina*)

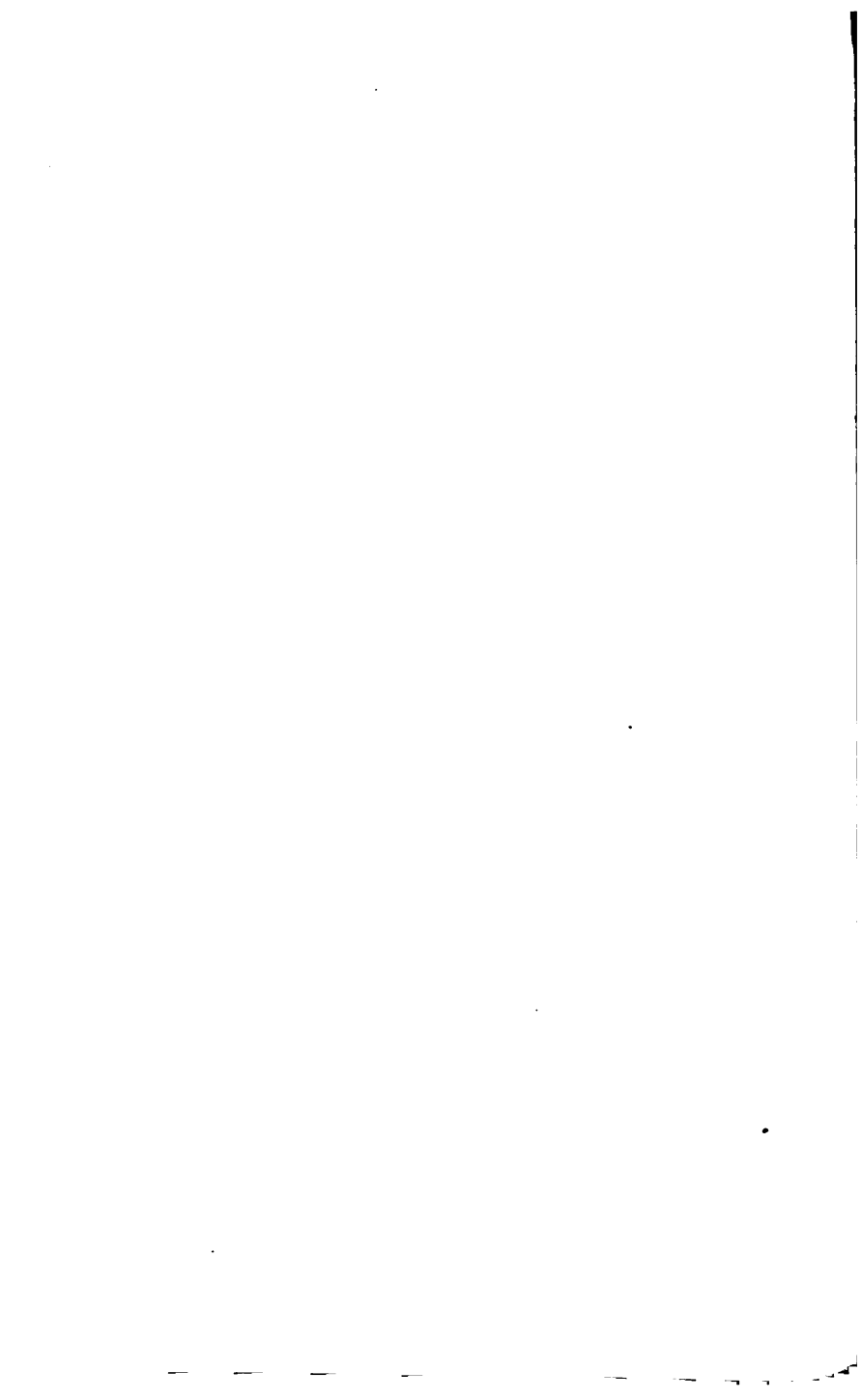

penetration to the spherical." This is quite in accordance with the experiments made by Mr. Boucher, and detailed at page 330 *et seq.*, and doubtless it is practically correct. The same author strongly advocates the use of the old polygrooved rifle, for this kind of game, and recommends the sportsman to arm himself with a battery of this kind of rifle as well as smooth-bores, all of No. 10 gauge, so that the same ammunition will do for all. His remarks appear so much to the point on this subject, which is wholly beyond my experience, that I shall extract them from *The Field*, as follows:—

"All good sportsmen naturally try experiments as new inventions are produced. If the Dinotherium or other antediluvian monsters now existed, we should as speedily discover means to crack their heads as Armstrong and Whitworth did to pierce the iron-sided ships; but for the animals of the present world, a double No. 10, with spherical or with belted ball, is sufficient.

"The difficulty of loading a polygroove rifle is much exaggerated. Formerly bullets were fitted so tightly that they required hammering into the muzzle. This was an absurdity, and produced a great amount of trouble. The explosion of the charge always expands the spherical bullet sufficiently to ensure its taking the grooves, although it may be of that easy fit that a moderate pressure sends it home. All spherical bullets should be rolled up in wax-cloth (linen dipped in melted bees-wax), then rubbed between the hands until it firmly adheres. The creases or folds should then be cut off with scissors quite close to the ball, which should be again rolled between the hands. It will then be so neatly covered that it will appear like a ball of wax, and so tightly will the covering adhere that it will accompany the bullet in its flight. The balls thus covered should be greased with hog's lard, goose fat, or other lubricant, when required for use. What can be more convenient on a hunting expedition in a far country than a batch of such rifles, and a couple of smooth-bores, all No. 10? There is no confusion of bullets; the same bag holds them all, and half a dozen moulds being taken, you are not driven to despair by the loss of one. If the hunter has a determined fancy for the conical ball, he can

use it with such a battery equally with the spherical, although he will, in my opinion, thereby waste an unnecessary amount of lead, the latter being of no small importance during an expedition in a distant country.

“When I first visited Ceylon, in 1846, full of the mad enthusiasm for wild sports which had led me thither, I was armed with a large rifle, a single-barrel three-ounce two-groove, weighing twenty-one pounds, which had been manufactured from my own design. With this I had tried so great a variety of experiments that I concluded no animal could stand against it if loaded with twelve drachms of powder, and I frequently used it even with *sixteen*. No animal could withstand that gun if held straight; but what was my astonishment upon my arrival in Ceylon! Elephants were never shot with rifles! There were great names in that land of elephants, and I trust both the dead and the living will pardon me for mentioning them with honour—‘Rogers,’ ‘Gallwey,’ ‘Skinner’—who counted their elephants by many hundreds, all of whom had bagged their mighty game with the common smooth-bore fowling-piece. I believe I was the first person to suggest the rifle as a superior weapon for such game, and at that time there was a strong prejudice against it, owing to the idea that aim could be taken quicker with the smooth-bore. There can be no question that the heavy rifle is superior to the smooth-bore, as a longer shot may be taken with certainty at an elephant when charging, or he may be bagged when retreating at a distance that the hunter could not make up if thoroughly blown, in which case the smooth-bore would fail. But in spite of my heavy battery I had a little pet in the shape of a double smooth-bore, No. 16, weighing certainly under seven pounds, and I never felt more confidence than when I held this trusty little piece loaded with $4\frac{1}{2}$ drachms of powder. Startling as this charge may appear, the little gun bore it for many years of hard work; and with this charge I should have no confidence to advance to close quarters, unless I had seen the powder well up in the nipple previous to capping. This can seldom be done if coarse powder is used. In loading for dangerous game I always adopt the following careful plan, which I recommend to others:—First, put the rifle on half-cock;



THE POLECAT (*Putorius arcticus*).



THE WEASEL (*Mustela vulgaris*).



then blow hard down the barrel, and, placing the finger about half an inch from the nipple, feel if a good volume of air passes freely through; then snap a cap upon each nipple, holding the muzzle downwards, pointed a few inches toward any bit of straw, paper, or other light object lying on the ground. If this be blown sharply away, all is right; the cap has dried the barrel from any dampness caused by your breath, and if you load with the finest-grained gunpowder, it will be seen fresh and glittering in the nipple. Look inside each cap before placing it, lest a piece of dirt or other substance should be in it; if it be clean, and one of Eley's 'double waterproof central fire,' nothing short of a miracle will cause your rifle to fail, and you can advance with perfect confidence to your game.

"For deer-shooting, there can be no better rifle than the No. 24 Pritchett ball; but we will confine ourselves, for the present, to 'large game,' for which I stated my preference in a former letter for the double No. 10 polygroove.

"In my experience I have never known a spherical bullet turn from its course; such things may have, nevertheless, happened to others. On the other hand, I have very frequently found conical bullets play the most extraordinary vagaries, not upon the bodies of deer or such tender animals, but upon the heads of elephants and the bones of buffaloes. Every fencer knows how slight a touch, obliquely given, will parry a vigorous thrust; it is precisely this action upon the conical ball which is produced by a hard bone struck obliquely, and a side glance is the general consequence. The blunter the cone, the less liable is it to this accident; and 'Elephantiasis' recommends a hemispherical termination, which is far preferable to a point, rendering a glance less likely, and giving a greater shock from the larger surface struck. Nevertheless, I object generally to the cone even with this improved termination, as so large a mass of lead in proportion to the bore of the rifle is subject to a grave disadvantage."

Mr. Baker's extensive experience entitles his opinions to a most favourable consideration, but I am doubtful whether he has tried the cylindro-conoidal ball under circumstances favourable to it. It is now generally admitted that the cone should be a very blunt one, and that as far as penetra-

tion at short distances is concerned, a flat head is preferable even to the hemisphere recommended by "Elephantiasis." Until recently all cylindro-conoidal balls terminated in a sharp point, and such a shape is undoubtedly likely to lead to their glancing off when striking any hard substance obliquely, as reported by Mr. Baker to have happened to him. There is another objection to the use of expanding balls against large game, consisting in the necessity which attaches to them for using soft lead, whereas the spherical non-expanding ball, whether belted or not, may be hardened by alloying the lead with tin or other metal, which will have a better effect in producing that result. The use of very fine powder is doubtless advantageous in ensuring certainty of explosion, but it is prejudicial to effectual penetration; and a strong military cap will explode the coarsest powder ever employed for rifles, if the nipple is properly constructed. Sportsmen object to them as being dirty, and causing extra trouble in cleaning, but these qualities, objectionable as they are in a trifling degree, should not be allowed to weigh against their efficacy in point of certain ignition. With reference to the use of smooth bores for large game, it may at once be conceded that with a spherical ball at a very short range, not exceeding 20 yards, they will give excellent results, provided extreme accuracy of aim is not desired. But if the ball must be delivered within a circle of six inches, even at 20 yards they cannot be depended on, and beyond that distance their shooting is a perfect lottery.

That a ball of large diameter will produce a greater shock on the animal frame than one of a smaller size, is indisputable; but this is entirely a different matter from that which relates to the comparative effects of spherical and cylindro-conoidal, or, more properly, cylindro-hemispherical projectiles.





THE KESTREL (*Milvus Regalis*).

BOOK VI.

THE GAME PRESERVER'S GUIDE.

CHAPTER I.

DUTIES OF THE GAMEKEEPER.

ONEROUS NATURE OF THE TASK—HONESTY—KNOWLEDGE OF LAW
NECESSARY—NUMBERS REQUIRED—THE KEEPER'S GUN—SELECTION OF
PRESERVE OR SHOOTING—CONTRACTS FOR TAKING MOORS OR MANORS—
CERTIFICATE.

ONEROUS NATURE OF THE TASK.

There are few offices which require more highly-developed bodily and mental qualities than that of the man appointed to the task which we are now considering. He must be of strong body, yet cautious in the use of his strength. Quick in intellect, so as to be able to counteract the plans of the poacher, he should be also steady in carrying out his own. With a fondness for out-of-door sports he should combine some considerable love of reading, so as to make himself master of what is going on in relation to his own special department in other parts of the world besides his own. He must be a boon companion without being a sot, the former quality being desirable, in order to conciliate the good opinions of his neighbours, while the latter is fatal to his success in many points of view. Of course it is scarcely to be expected that any individual shall possess all these qualities combined in the highest state of perfection, but the nearer he reaches to this, the more fitted he will be for his office; and the absence of any one will often lead to his defeat or disgrace.

When it is remembered that the gamekeeper has to rear his game, which requires great tact and care; to trap vermin, which is a still more difficult task; to preserve his charge from poachers under laws the operation of which is most jealously watched; to break dogs of all kinds; to shoot infallibly well when required, and occasionally to take care not to shoot better than his master or his master's friends; it will readily be understood by those who know anything of these subjects, that I have not over-estimated the extent of the good qualities which are required.

HONESTY.

In the above list I have said nothing of the *summum bonum*—the apex of the pyramid. A keeper may be all that I have described: he may rear, and trap, and preserve to perfection, but then all this may be done for his own benefit, and not for that of his master. I have often known a good head of game early in the autumn dwindle down to a very moderate show when put to the test in September and October, clearly proving one of two things—either that the keeper had allowed the poachers to rob him, or that he had himself been guilty of fraud upon his master, by selling the game which he is paid to preserve. In most cases I believe that the fault lies in his neglect of duty, or that he has been outwitted, but sometimes there can be no doubt that the keeper has either directly or indirectly sold his game. The temptation when the master is non-resident on the property is very considerable, for unfortunately the keeper has still less difficulty in disposing of game than the poacher. No doubt he places himself in the power of his subordinates, but some risk must be run in all cases of fraud committed in other walks of life, and yet we know that they are of daily occurrence. Still it is highly creditable to the whole class of keepers that they are generally above suspicion in this particular, and what few instances have come to my knowledge have most of them been caused by some mismanagement or meanness on the part of the master.



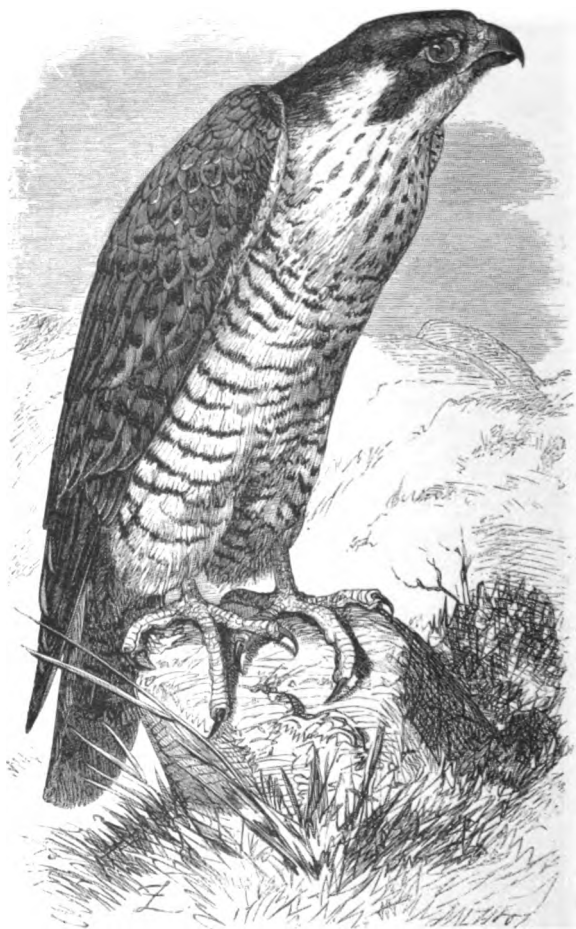

THE PEREGRINE FALCON (*Falco peregrinus*)

KNOWLEDGE OF LAW NECESSARY.

It constantly happens that the keeper is obliged to consider whether he shall be within the law in any action which he is about to commit. Poachers are constantly trying new dodges, and to meet these, new plans of operation are necessary, which may or may not be legal; and either the keeper or his master, or his master's lawyer, must settle this knotty point. Generally speaking, there is little time for consultation, and the keeper must make up his mind on the spot. Hence it is a great point in his favour if he is able to understand an Act of Parliament, and unless he does, he will be constantly obliged to consult his superiors.

NUMBERS REQUIRED.

When an efficient head-keeper has been appointed, it is desirable to know how many men he will require to assist him. At certain seasons of the year a few extra watchers will always be required; but what I am now alluding to is the number of regular under-keepers required. Much will, of course, depend upon the nature of his duties, for it is well known that in some districts game requires far more careful supervision than in others. The neighbourhood of large towns, and especially if footpaths pass through the manor, is exceedingly prejudicial to secure and easy preserving; and if a keeper has one so situated to look after he will require double or treble the average staff. For these reasons it is impossible to define the number of assistants required, and every master must in some measure be in the hands of his servant.

THE KEEPER'S GUN.

It is a much-disputed question whether the keeper should be allowed a gun at all, and there is also another, bearing upon the propriety of his being allowed to carry it at night. With regard to the diurnal use of a gun, I cannot but think that the keeper should never be without it. Those who have been much in the country must have observed that every now and then a chance of being near some coveted

object of natural history is obtained which rarely occurs a second time, and in the same way a keeper has the opportunity to shoot some kind of vermin when he has not got a gun, which all his trapping will fail to obtain for him in that way. He may, and often does, carry it for weeks without using it, but then comes the chance, and he will add to his list of vermin by its aid to a greater extent in one week than his traps have done in a month. Continual shooting will, no doubt, frighten game, and in that way do harm, but an occasional shot once a week or so has never produced that effect, and it is rarely the case that a keeper would be called upon to use his gun twice in the same locality within a week. We all know that vermin *may* be trapped; but when the gun comes in aid of that means it is so much gained. A bad trapper I would never employ, nor should I like a keeper who depended upon his gun rather than on his traps; but that some men have done this is no reason why others should not be allowed to use both. A stout useful keeper's gun may be bought new for from 10*l* to 15*l*. (See p. 253.)

SELECTION OF PRESERVE OR SHOOTING.

If the keeper is appointed before the ground, which he is to look over, is chosen, it is always well, if possible, to consult him about it. There are many little things which are likely to strike the eye of the professional in any department, which by the amateur are passed over, and besides this it is well known that we all undertake a task more willingly about which our opinion has been asked and taken. So much depends upon a hearty co-operation in the master's views by the keeper, that a little concession of dignity may fairly be made by the former to him, and I have so often known the opposite plan lead to a bad result that I would strongly advise its being avoided.

In choosing a manor in the south for the purpose of preserving pheasants, partridges, hares, &c., the master is inexcusable if he is taken in with regard to the head of game remaining, because he can so readily ascertain what is left. The spring is the usual time for letting manors, and at that period of the year it is extremely easy to show what



THE COMMON BUZZARD (*Buteo Vulgaris*).

[The page contains extremely faint and illegible text, likely bleed-through from the reverse side of the document. No specific content can be transcribed.]

game there is by running a brace of good dogs over it. It will not do to depend upon accounts given in the previous season of the head of game killed, for it may have been killed down too closely; nor should there be an agreement to take it in the spring after the season has concluded, because here the incoming tenant is in the hands of the one outgoing. So also, whenever the agreement is made, it should be arranged that the ground should be at *once* given up, for I have known a wonderful difference between the head of game, on an extensive beat, in the first and that in the last week of September. Keepers, we all know, *can* poach if they like, and if they are not to be retained by their new masters it is to be expected that many of them will take advantage of the knowledge acquired during their previous term of office. Wherever, therefore, you have decided upon taking a manor, make up your mind either to retain the keeper, if you think him trustworthy, or to displace him at once, if otherwise; although you are likely even then to lose a considerable quantity of game. It is evident that a strange man cannot compete with one who knows all the haunts of the game, as well as of the vermin attacking it; the old hand has the opportunity of robbing you if he likes, or if he does not do so directly, he can indirectly, through some of those half-poachers, half-keepers, with whom so many are in league. The best time to make choice of a moor or partridge manor is in the month of February or March, when you may, by a little perseverance, have ocular demonstration of nearly every head of winged game on the beat. By taking out a brace of strong and fast pointers or setters you may easily beat over a couple of thousand acres of arable land, or double that quantity of moor land, and you will thereby find at least three-fourths of the birds. In this proceeding you must take care not to let the keeper palm off the same birds upon you two or three times over, which he may easily do if you are not on your guard. To avoid this trick, observe the line which the birds that have been put up take, and instead of following that line, which the keeper will most probably try to induce you to do, just keep to the right or left of it. In beating, also, go straight a-head, if the manor is extensive, and do not follow

the same plan as if you were shooting. Take one field after another in a straight line; and though you will not thereby see so much game as you otherwise would, you will, at all events, avoid the mistake of fancying that there are 150 brace instead of 50. With regard to pheasants, you may always be shown these birds at feeding-time, as the keepers know where to find them as well as barn-door fowl. If, therefore, they are not shown, depend upon it, *if it is the interest of the keeper to show them*, that they are not in existence. As to the number of hares and rabbits, you may generally make a pretty good guess at them by the state of the runs and meuses. If these are numerous and well used, there is sure to be plenty of fur; or at all events there has been till very recently. The spring months are also the only ones in which vermin can be successfully trapped, and therefore you have every reason for taking your moor or manor at that time of the year.

There are sundry points of importance by which likely ground may be known. In the south, where pheasants and partridges are to be preserved, there should be one or more large coverts *in the centre*, in which pheasants are secure at all seasons, and in addition a number of small ones, which are all the better if in the form of belts. A belt surrounding a property, as is too often the case, is by no means desirable, because the pheasants in it are sure to feed upon the adjacent lands, when they are liable to be shot or poached. If the corn is all bagged, or the stubbles are mown directly after harvest, or if the course of husbandry leads to their being broken up soon in the autumn, the partridge shooting will not be good, unless there are plenty of turnips, mangold wurtzel, seed-clover, or other green crops. A light sandy soil suited to turnips is also that which partridges thrive upon; but there must be water at all seasons, or in a dry one they will be liable to die away wholesale. So also with the pheasant-coverts; they ought all to have water in them, and this should be perpetual, and not merely a winter pond, liable to be dried up in the summer. In the choice of moors, as well as in that of manors, the management of the adjacent beats should be taken into consideration. Game being one man's property to-day and his neighbour's to-



THE HEN HARRIER (*Circus cyaneus*.)





THE SPARROW HAWK (*Accipiter Nisus*)

morrow, it follows that there must be a "give and take" system continually going on, and if the adjacent lands take all they can and give none in return, the effect is felt in the course of the year. But moors require special circumstances to be examined into. There is a necessity for a certain amount of old heather to protect the birds, not only at the breeding season but all through the year, and if this is not in existence the moor cannot be a good one for a number of years, as the heather takes seven years to attain its full growth. But, supposing that there is a good crop of old heather left, provision must be made that it shall not be burnt in too great a quantity annually. A certain extent of burning is desirable, but all that is destroyed beyond a seventh or eighth of the whole area tends to the reduction of the desirable extent. These points, therefore, must be carefully looked to, and the lease so arranged that an excessive burning will vitiate it, or be met by the payment of a penalty on the part of the landlord.

CONTRACTS FOR TAKING MOORS OR MANORS.

In all contracts for taking manors or moors the agreement ought to be in writing, and properly executed on a stamped paper. The following form has been found to answer all the purposes required, and is more simple than most of those in general use:—

MEMORANDUM of an agreement made this day between A. B. of —, and C. D. of —; the said A. B. agrees to let the said C. D. (without power of sub-letting or assigning) the whole of the game on the lands, farms, or moors in the parish of —, from this present date to the — of —; that is to say, that he, the said C. D., shall have full power by himself, or others having his authority, to kill game over the above-named lands, during all lawful times and seasons. And in consideration of the same permission of A. B., the said C. D. agrees to pay the sum of — on the 25th day of January in each year; but the first payment to be made at the signing of these presents. And the said C. D. further agrees that he will preserve the game in a fair and proper manner, and that he will not destroy, in the last year of his

tenancy, more than he has done, or ought to have done, in the previous ones.* And in case the quantity of heather burnt in any year on the said moor is greater than the average of the last five years, the said A. B. agrees to pay to the said C. D. any such sum as may be considered the amount of damage by the arbitrators chosen as below mentioned. And, in the event of any difference of opinion, it is further agreed by and between the parties to these presents, that the same shall be referred to two arbitrators, one to be chosen by each, with power to choose an umpire, if necessary, whose decision shall be final. In witness whereof we do hereby sign our names, in the presence of E. T. ; A. B., C. D. Dated this 25th day of March, 1855.

KEEPER'S CERTIFICATE.

This will be alluded to under the head of the Game Laws.

CHAPTER II.

REARING GAME.

THE KINDS WHICH CAN BE REARED ARTIFICIALLY—METHODS OF OBTAINING EGGS—HATCHING—REARING—KEEPING TAME PHEASANTS—TURNING OUT—REARING GAME IN A WILD STATE.

THE KINDS WHICH CAN BE REARED ARTIFICIALLY.

Among the varieties of game which are met with in this country, pheasants are the only ones which can be reared with any great advantage by artificial means. Partridges, black-game, and even red grouse can be bred in confinement, but the trouble and expense attending upon the plan are so great as to prevent its ever being adopted on anything but a very limited scale. But pheasants may be hatched under a domestic hen, and brought up by hand in any number, the

* To be added when a moor is taken, but not required for any other kind of preserve.



TOX HERRY (*Hypotriarchis Subbites*)





THE MERUS (*Hypobriochus Esalon*)

chief danger being of their contracting the diseases which attack the poultry-yard, and especially that known as "the gapes." It is found by experience that whether the wild pheasant is allowed to sit on all her eggs or not, in most seasons she will only rear about seven or eight young birds; and so if the keeper can take half her average number of eggs from her, and put them under a hen, all that he brings up may be considered as clear gain. When woods are to be heavily stocked this hand rearing is all important, for without it a large head of game is found to be beyond the powers of the most careful and experienced keeper. The hen cannot cover more than half her brood when they grow into anything like size, and at that time they contract colds, &c., and die off with the result which I have alluded to above. Nor can the wild hen pheasant find food for more than a certain number, while the keeper has it in his power to obtain unlimited supplies for his tame birds. Hence it has come to pass that for high preserving the artificial rearing of pheasants is universally adopted.

METHODS OF OBTAINING EGGS.

The great drawback to the artificial rearing of game is the temptation which is offered to keepers to procure the eggs necessary for the purpose by improper means. They are constantly offered to him by loose characters, who obtain them by robbing the nests; and too often it happens that the keeper buys them regardless of the mode in which they are obtained. The competition in getting a good head of game is so strong that neither keeper nor, very frequently, his master, cares much how the thing is done, so that it is done; and as eggs must be procured somehow, the robber of the nest gets rewarded instead of being punished. The penalty of five shillings per egg is very easily enforced, but we rarely hear of the law being carried out, for the simple reason that very few keepers can come into court with clean hands. Yet nothing can be more suicidal than this, for every one is robbed in his turn; and many a preserver pays for his own eggs, which would remain in their nests if there were no premium for the robbery offered by himself and his

neighbours. No doubt a law which should make the sale of the eggs of game birds altogether illegal would add to the difficulty of procuring them, but then it would still more diminish the necessity for them, because there would be more nests naturally brought to maturity.

There are three modes in which eggs may legitimately be obtained:—1st, From nests which are found in mowing grass, and which are chiefly those of partridges; 2ndly, by taking away a certain number from each nest without disturbing the old birds; and 3rdly, by keeping tame pheasants in confinement for the express purpose. Of these the *first* is the least useful, because the eggs are almost always partially set on, and unless a "broody" bantam hen is at hand they will be rapidly spoiled. Machines known as Incubators have been suggested in lieu of these birds, but there are few gamekeepers who can manage them; and, I believe, they would seldom pay for their cost. Some keepers take care to have three or four hens always sitting during the mowing season, and by substituting the eggs of the partridge or pheasant for their own, the value of which is not very great, the former are brought to maturity. This resource, however, is not one on which great reliance can be placed.

The second plan is one which is largely practised by some most successful game-preservers, but it is chiefly applicable to pheasants. As I have already remarked, very few hen-pheasants rear more than eight birds, though they lay from ten to fourteen eggs, or even sometimes a greater number. The difference between the number of the eggs and of the resulting birds arises from the death, produced by exposure to the weather, of those young birds which the mother cannot cover with her wings; and it is found that if she has only seven or eight to begin with she will rear them all, and they will also be far stronger and better fed birds, from the hen being enabled to procure more food for them. The keeper, therefore, takes care to find each nest, and while the birds are on the evening feed he takes from it all above seven or eight, which are left to be hatched in the usual way. In an ordinary preserve this ought to give sufficient eggs for artificial rearing, with the addition of the third plan, to be next described.

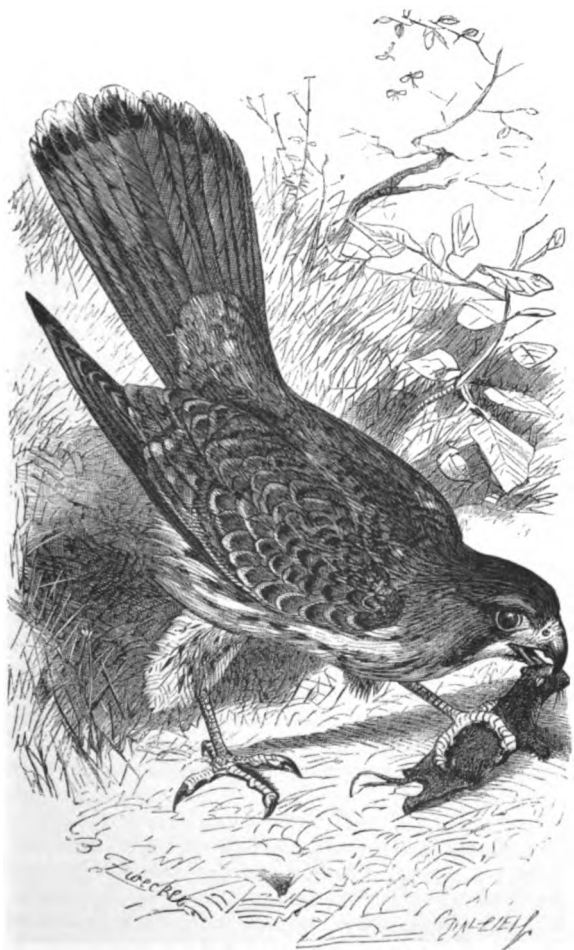

THE MALE KESTREL (*Tinnunculus Alaudarius*).



Three, four, or five tame-bred hen pheasants are put into a pen with one cock, a difference of opinion existing as to the best proportion for the purpose, but this will vary much according to circumstances. Some strong healthy cocks will do better with four or even five hens than with three, while others again will scarcely fructify the eggs of the smallest number of hens mentioned. Wild birds will lay in confinement if they are put in a quiet place and not disturbed, but they will not produce nearly so many eggs, and of what they do lay a large proportion will be added. If wild birds only can be procured, the best plan is to cut one of their wings, and make a large walled enclosure in the middle of a quiet covert, open over head, into which the wild cocks come. The hens make their nests in the usual way, and these are robbed of their eggs as fast as they are laid, taking care to leave a nest egg. Sometimes in this mode twenty eggs a piece may be procured from wild hens, but rarely above that number, while tame hens will generally lay from twenty-four to thirty eggs each. The above plan is a good one, even with tame-bred hens, which should have one of their wings cut in any case, for, however careful the breeder may be to avoid frightening them, such an event will occasionally occur, and then if full-winged they fly up against the cover, and crush their skulls or break their necks, if it is solid, or hang themselves in a mesh if it is of network. Pinioning is an unnecessary cruelty, and as it is permanent the hens can never be turned out. Moreover, the cutting of the quill feathers close to the wing bone is equally efficient if it is done as fast as the feathers grow during the moulting time.

HATCHING.

A large bantam is the best kind of hen for the purpose of hatching game eggs, but she will not cover so great a number of them in the nest, nor can she foster so many young birds from the cold as a larger hen. A game hen, or, in fact, a hen of any small breed, will do very well, and being of larger size than the bantam will hatch and rear a dozen or fourteen young pheasants or partridges. Very large hens are objectionable from their tendency to tread on the young birds, which their weight is then sure to destroy.

A box, with a lid to it, from a foot to eighteen inches square, should be provided for each hen, and when the "broodiness" is fully established, put some hay in it sufficient to make a comfortable nest, and in this place the eggs. The lid should have a number of holes cut in it with a centre-bit, for ventilation, and should be capable of being fastened down with a hasp and padlock in the usual way, which will allow the box to be safely left in places where it might otherwise be liable to interference. If several hens are sitting at the same time, the eggs may be examined at the end of the first week while the hens are feeding, and then if one-quarter or one-fifth are addled, which is about the usual proportion, they are removed, and making four nests into three, or five into four, according to the numbers, one hen is set at liberty for another hatch. The mode of distinguishing the addled eggs is simple enough. Take an egg and hold it, with the hand closed round it, between the eye and a strong light, when if it is good a dark speck will be visible at the end of five or six days from the commencement of sitting. A little practice is required in this operation; but by looking at a few with care the difference is soon detected. Nevertheless, it is well to depend upon an experienced friend in the first instance. Pheasant eggs are hatched in twenty-four days; those of partridges in twenty-one.

Every hen bird naturally leaves her nest daily for a longer or shorter period in order to attend to the calls of hunger, by which another purpose is served connected with the due aeration of the eggs. On the average, three-quarters of an hour will be the time during which the hens are off, and this is sufficient to lower the temperature very considerably. As a consequence, the portion of air contained in the cell at the end of each egg contracts as it cools, and draws in through the pores of the shell a fresh supply, which, mixing with the whole quantity, affords fresh oxygen once in each day. When the heat is again raised, a part of the whole is forced out again by its expansion, and so day by day a kind of partial respiration is carried on essential to the due performance of the act of incubation, and necessarily imitated in artificial machines by lowering the temperature for an hour every day. If the hens are close sitters they

may be taken off one at a time, and left to satisfy their hunger and thirst with the food and water supplied to them, as well as to dust themselves in a heap of rubbish, which should always be at hand, after which they will return to their nests in good time, when the lids may be put down and locked. If, on the contrary, they are slack sitters, they may be taken off and put under a large coop, with food, water, and dust at hand, and at the expiration of the proper time they may be replaced on the nest by hand and covered down; but unruly hens are very apt to break their eggs in this way, and it is better to let them return of their own accord, if they will do so, but they should be carefully watched. In very warm weather the time should be a full hour, while if it is cold forty minutes will be long enough. To ensure the proper change of temperature in hot weather, some people sprinkle the eggs with cold water, and it is by no means a bad plan, especially towards the latter part of the sitting.

As the hatching time approaches, while the hens are off the nest, every egg should be carefully inspected, and if there are several hens expected to come off on the same day, it should be so arranged that one should have all the first hatched, another the second, and so on. This is effected by exchanging the eggs as soon as they are seen to be chipped, giving all the first to one hen, who will thus be off the nest with her brood before the others. As soon as all are hatched in one nest, the hen is put under a coop with a small covered run for the young birds, in which they will remain for a few days. It should be made as follows:—A pen is made of wood on all the sides but the front, which is of wire net, and has a space at the bottom sufficient to allow the young birds to pass under but not the hen (see *a b* fig. 94 on next page). To this a small run, *c d*, is attached, and also covered with wire net, and in it the young birds are fed. The whole has a boarded floor, which should be capable of being removed at pleasure by means of pins at the angles.

The rearing commences by feeding the young birds in the above pen or coop, taking care to choose a sunny spot for it. The food should be hard-boiled eggs chopped fine, mixed with rice, which should be carefully boiled in plenty of

water so as to keep every grain separate. Cooks know how to do this in boiling it for curry, and they will readily show

Fig. 24.

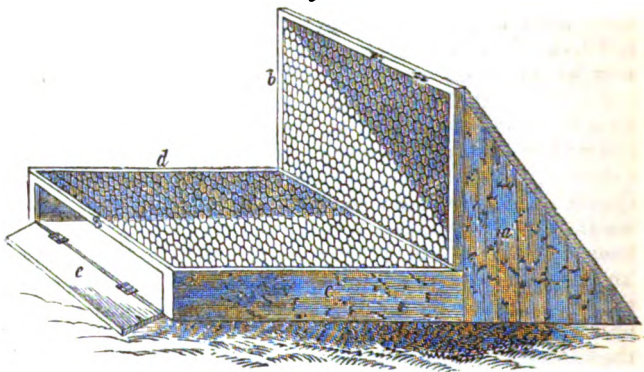

PEN FOR YOUNG PHEASANTS.

the method to the keeper if he is ignorant of it. Curds chopped fine may also be mixed with barley meal, which should be of such a consistency as to be capable of being divided into little pellets of the size of half a pea. Bread crumbs softened with milk; ants' eggs and scoured gentles may also be given—the two last being especially useful. Change of food is most essential; and it is better never to give any of the above kinds consecutively, or at all events not more than twice, though ants' eggs can scarcely be given too freely. The feeding should be at first five or six times a-day, gradually reducing the number to three at the end of a fortnight.

In procuring the above kinds of food the great difficulty is with the ants' eggs, which are very scarce in some localities. It is worth while, however, to take a good deal of trouble to obtain them; and there are few counties which are without waste ground on which they are to be found. Next to them come the gentles, which are easily bred and scoured in the following mode:—Procure any kind of flesh, or the body of

any small animal. If there is any difficulty about this, the liver of a horse or cow answers remarkably well. With a knife cut some deep gashes in the substance of the liver or flesh, and hang it up in a shady place, but near the haunts of the blow-fly. Where a large number of pheasants are reared an outhouse is specially provided, the incursions of sparrows being prevented by wire-work or netting. In a few days the maggots will attain a lively state of existence; but they require about a week to reach their full development to the green or soft state, and another week to reach their maturity, when they are large and fat, with black heads. Blow-flies are abroad after the beginning of May. The *scouring* of these gentles is effected by placing them for a few days in a mixture of bran and fine sand, slightly damp. By this process they are emptied of their contents, and rendered tough in their skins; in which state they will not purge the young birds. When the object is to preserve them for many days, they must be kept in a very cool place, such as a cellar, or they even should be buried in the earth. Without attention to this precaution they are almost sure to assume the chrysalis condition, in which stage they are useless for feeding. A low temperature, and the exclusion of air and light retard this development; but in most cases the young birds will require the gentles as fast as they are sufficiently scoured. The curds used are those to be obtained at any dairy.

As soon as the young birds are strong enough, which will be at the end of a few days, or perhaps a week, from the hatching, they will require a run on grass. For this select a dry field, with a south-western aspect if possible, but carefully avoiding such as are exposed to the east or north. A slope to the sun is generally preferred, as it allows the rain to run off as fast as it falls; but it is well to provide against the flooding of the coops by digging a trench above them to carry off the water sideways. The young birds are extremely fond of high grass, which not only shelters them from the sun and from hawks, but allows them to find insects, so that it is well to leave parts of the field uncut. Broad paths must, however, be mown through it for the coops or rips, and on them, at intervals, the latter are placed, re-

moving the bottom, and turning the sloping back towards the sun so as to give the hen shade. At first, till they are settled in their new abode, the birds are to be confined in the pen, but on the second day the flap (*e*, fig. 94) may be let quietly down, and the young birds will then gradually find their way out and wander among the grass. The call of the hen soon brings them back; and they should always be fed in the small run of the pen, where, also, spring water should be constantly kept, and changed regularly three times a day—it is a good plan to boil it. The flap of the run is shut at night, which keeps out rats and stoats; but the young birds must be let out at sunrise, when they should have their first feed. Every day the coop should be shifted to fresh ground, so as to avoid keeping them on that which has been stained. A shallow box of dust should be provided and moved near the pens to allow of the young birds dusting themselves, and this is more especially necessary with partridges. After the birds are six weeks old the food is gradually changed to barley, buckwheat, or split Indian corn.

KEEPING TAME PHEASANTS.

As the young birds grow to full size and are able to fly, they may either be removed to large pens, covered with netting if they are to be turned out, or they may have the feathers of one of their wings cut, and will then be easily kept in by hurdles without covering overhead. Pheasants do not require shelter of any sort beyond that which will be afforded by light faggots, or other similar materials. The hurdles should be made of split spruce laths for perpendiculars, while the horizontal rails must be of rough oak; they should be about seven feet high, and should each have a strong slanting prop fixed to the middle rail (fig. 95), by which they may be supported while they are being fixed to one another, after which the whole square is perfectly firm. Each hurdle may be made ten or twelve feet long, and four of these being arranged at right angles, and their corners tied securely together, leave a square within them of sufficient area for one lot of birds consisting of a cock and from three to five hens. A larger quantity should not be put together for breeding; and it is better to add three more hurdles to one

of the sides for a second pen, than to place more than six adult birds in a larger one. These pens should be moved to

Fig 95

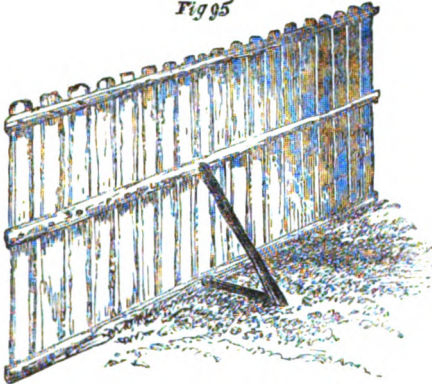

HURDLE FOR PHEASANT PEN.

fresh ground every month, except during the laying season; and for this purpose a door should be made in one out of each four, which will also admit the keeper at all times to the interior. When, therefore, the pen is first put up, take care and place the door on that side where the removal is to be effected, and then by fixing three other hurdles to that side, another pen is completed, and the keeper, opening the door between the old and the new, enters the former and gently drives the birds into the latter, shuts the door, and takes down the three hurdles which were used for the first pen, and are now no longer wanted. When the square is completed a strong rail is tied to four props across the middle space, and over this faggots, or loose brushwood are arranged so as to leave a run underneath, when the birds are secure from interference. If the birds are to have their wings cut no net is necessary, but if not a common net is fixed over the top, and in that way the birds are confined.

When the feathers of the wings are to be cut, the birds must be caught; and for this purpose a net, something like a landing net for fish, is to be employed, but larger. A strong

oval ring of iron wire is attached to a pole, six or seven feet long, and a loose bag net fastened to it all round. Armed with this, the keeper enters the pen, and readily places the net over the pheasant, which may then be laid hold of in the usual way. All the strong wing feathers must be cut close to the flesh, and this must be repeated during the moulting, or they will grow long enough to allow of the birds flying over the hurdles. Pulling the feathers out should never be practised, because they do not grow again as strongly as before.

The best food for adult pheasants and partridges in confinement is barley, wheat, split Indian corn, rice, and buckwheat—each of them being used for a term, and then changed for another. Green food—such as cabbage, turnips, and turnip tops, lettuce or mangold wurtzel, should also be supplied for them to peck at; and some kind of animal food must occasionally be given to supply the place of the insects which would be taken if the birds were at liberty. Chopped beef or horseflesh is the best, unless the bones with a little meat on them can be put down; for the birds like to peck the flesh off them by degrees, and not to be gorged with it in large quantities at a time. Flesh maggots answer still better; but they can only be supplied during the summer season. Earth worms, when they can be procured, are excellent at all times. Plenty of dust, with a fair proportion of sand and lime, should always be within reach of partridges and pheasants.

The diseases to which these birds are subject during their rearing are chiefly diarrhœa, the gapes, and cramp. Diarrhœa may be relieved by giving rice boiled in alum water, adding a few grains of black pepper, if the birds are much exhausted by it. The gapes is one of the most troublesome of the diseases to which these birds are subject; it is caused by a parasitic worm in the windpipe, which is several weeks growing to its full size, gradually causing suffocation by filling up the air-passage. Nothing does any good but the dislodgement of the worm, and this may be effected by means of a feather dipped in equal parts of olive oil and spirit of turpentine, which is then passed down the windpipe *in front of the throat*, and not into the gullet, which is behind. Some

skill is required for this, and where it is not acquired, fumigation with the vapour of spirit of turpentine will succeed nearly as well. This is done as follows:—A box containing two compartments (fig. 96) is framed of wood;

Fig. 96.

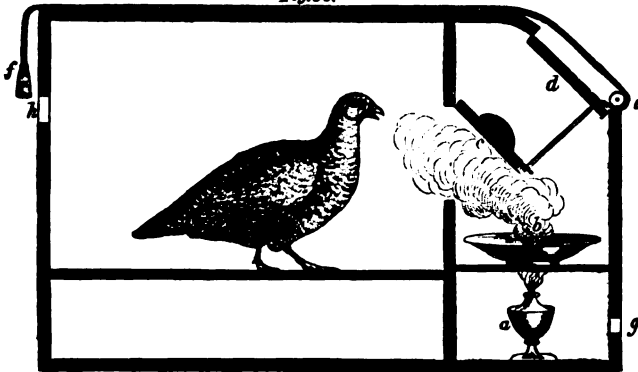

INHALER FOR GAPES.

one of these is large enough to contain the pheasant, and has a door, provided with a loaded valve *c*, which opens and shuts in unison with another valve *d* by means of a rod between them; *h* allows of the escape of the vapour, which enters through the opening below *c*. In the other chamber is a spirit lamp *a*, a saucer containing the spirit of turpentine *b*, placed upon a wire gauze partition, so that the vapour from it shall not be lighted by the flame of the lamp; *e* is a small pulley, round which a cord passes from the upper valve *d*, to the hand of the operator, who is stationed at *f*, where he can watch the bird, and at the same time cause it to keep its head towards the opening where the vapour enters; *g* is an opening for the entrance of a current of air to pass with the vapour into the second chamber. When the pheasant is to be operated on, it is first placed in the box, the lamp is then set going, and the cord *f* pulled tight, by which the vapour is compelled to enter beneath the valve *c*, and this is continued until the

bird shows symptoms of oppression, by increased gasping and struggling to escape. If it seems quite overpowered, shut either entirely or partially the valve *c*, by loosing the cord at *f*, when the vapour escapes into the outer air through the valve *d*, and the bird soon recovers. The turpentine produces a good deal of irritation in the throat, with a tendency to cough, which, aided by its irritating effect upon the worm, generally causes the latter to be discharged, and the pheasant is cured. Tobacco smoke is used in the same way, but is not so certain a cure as turpentine. This disease may generally be prevented by using boiled water for the drink and food of the pheasants, and by taking care that they have no access to stagnant pools.

The cramp is caused by cold and wet, and may be avoided if the young birds are kept dry until they are quite strong. Strangely enough, the dew on the grass never seems to produce it, and on the other hand is highly beneficial. When cramp occurs, the legs should be put in warm flannel, and a pill containing a quarter of a drop of creasote administered.

TURNING OUT.

If *pheasants* are to be turned out, a pen should be made for them in the middle of the covert where they are wished to remain, and here they should be confined by a net over it for a few days. Then removing the net at night, they will quietly fly out without being frightened next day, and will not be likely to leave that particular covert. They should be fed in or near the pen regularly. Partridges are best treated in the same way, putting their pen in the corner of a quiet field, or in any situation where they are not likely to be disturbed. Pheasants that are intended to be turned out should be early encouraged to roost in trees; and if they can be reared close to the covert they are to stock, so much the better. Wild birds must not be penned in the above mode.

REARING GAME IN A WILD STATE.

To rear a good head of game requires only a moderate stock for breeding to begin with; but in addition to this, they must be kept undisturbed by vermin, men, or dogs.

Pheasants must be fed, if they are in large numbers, and for this purpose the wheat or barley used is better in the ear. A small stack should be made loosely in the covert, and here the pheasants will work at the grain, and earn their food, which all animals should do. Sparrows and other small birds get their share, but they are unable to pull out the ear from the stack, which the pheasant soon learns to do. Partridges require no feeding, but they must be carefully protected from the attacks of vermin. This will form the subject of the next chapter.

CHAPTER III.

VERMIN AND THE MODES OF DESTROYING THEM.

THE CAT—MARTEN—FOX—POLECAT—STOAT—WEASEL—RAT—HEDGEHOG—EAGLE—KITE—PEREGRINE FALCON—BUZZARD—MARSH HARRIER—HEN HARRIER—MONTAGUE'S HARRIER—SPARROW HAWK—HOBBY—MERLIN—KESTREL—BARN OWL—BROWN OWL—RAVEN—CROW—HOODED CROW—JACKDAW—MAGPIE—JAY—TRAPS AND TRAPPING—THE VERMIN TERRIER—POISON, AND THE MODE OF LAYING IT.

THE keeper who wishes thoroughly to understand his business will take care to make himself master of the habits and haunts of the various kinds of vermin infesting, or likely to infest, his beat, for without this he will always be likely to be foiled in his endeavours to discover and destroy them. Before, then, I discuss the methods of trapping, poisoning, or shooting vermin, I will give a short account of each, beginning with the worst enemy to game of all—

THE CAT (*Felis domestica*).

The cat is familiar to all of us as she appears at the fire-side; but when she takes to the game preserves she is very different in her habits, and even in appearance she has assumed more the wary look and fierce eye of the tiger than the calm and peaceful expression of the parlour pet. The moment a cat takes to a covert she is doomed, for war must

be waged against her to extermination, even if she is the favourite of the household to which the game preserve is attached, or there will be a poor show of game. From the time that the young partridges are hatched to the full fledging of the pheasant, a brace at least will fall to her talons in the course of every twenty-four hours, which is rather a heavier price than most fathers will pay for their daughter's favourite; but the question is seldom debated, for the very first appearance of grimalkin is a sure precursor of her speedy fall by trap, poison, or gun, whichever is the favourite engine of destruction of the keeper. The steel trap, the hutch trap of full size, or the wire, will either of them take the cat; but the last is unsafe, as it can scarcely be set without risking the death of a hare instead. Indeed, I have more than once known a poacher's wire take a cat, whose cries have soon brought out the keeper, for the cat does not hang herself like the hare.

THE WILD CAT (*Felis catus*) is now almost unknown in this country, being very rarely found in Scotland. It may be recognised by its shorter and more bushy tail, which has an abrupt end, by its larger size, and more uniform colour.

THE MARTEN (*Martes abietum et fagina*).

There are two varieties, the pine and the beech marten, the latter of which is portrayed in the accompanying illustration. Each frequents the woods from which it takes its name, and consequently the pine marten is more common in the north, and the beech marten in the south. In their habits they do not otherwise differ, both inhabiting the hollows of trees or old nests, such as those of the magpie. They produce three or four young, and at that time especially are very destructive to young game. They feed also on mice, rats, rabbits, leverets, squirrels, and pheasants and partridges, besides other birds. In colour they are of a reddish brown, the under parts being more or less white, with a tinge of orange at the sides. The marten runs very rapidly, and climbs into trees, jumping from one branch to another nearly with the agility of the squirrel. If hunted with dogs it generally enters some hole or crevice in the

rocks, but is readily bolted either by sending in a small terrier or by smoking. It is easily trapped, and a good vermin dog has no difficulty in killing it in the same way as a cat—that is, by turning it up and seizing it between the fore-legs.

THE FOX (*Vulpes vulgaris*).

Foxes are sacred throughout England, Ireland, and the lowlands of Scotland, where indeed they are rigidly preserved, the reproach of being a “vulpecide” being almost as bitter a taunt as can be hurled against any man short of the accusation of actual crime. In the highlands of Scotland and North Wales, and indeed in some of the hills of Ireland, inaccessible to hounds, the mountain fox is so destructive to game, and even to lambs, that in each district in the first-named country a “tod-hunter” is appointed to the office of finding and destroying the young litters, as well as the full-grown foxes, when he can reach them. In the present day the cubs, as well as the old foxes, bear a money value in the market if taken alive, being sent to masters of hounds in the south, who are always ready to take them, as the mountain or hill fox is a finer animal than the lowlander. The former is generally short, with grey hairs all over, and his tail is also thicker and more bushy, though not of greater length than that of the southern fox, which is now so much crossed with French and German blood as to retain little of his original peculiarities.

THE POLECAT (*Putorius fætidus*).

This animal, also called the *fitchet* and *foulmart*, is very common throughout those parts of the country which are not strictly preserved; but being to all kinds of game one of the most destructive of all the vermin tribe, he is carefully destroyed by all good keepers. The appearance of the polecat is well shown in the annexed woodcut, the colour being a rich brown black on the surface, over an under-coat of yellow. He is somewhat larger than the ferret, with which he readily breeds, producing the dark variety of that animal shown at page 152. His smell is peculiarly rank,

especially when excited, and hence his name of foulmart. Even his hole may readily be detected by the scent which it emits. It is generally made in a sandy bank, and often under the roots of an elm or ash, standing in a hedgerow, so that the keeper, when he has found it, has some trouble in digging him out. The polecat is only abroad by night, and is very apt to shift his quarters, so that, however clear a preserve may be at any season of the year, it is never safe from the invasion of these animals. The poultry-yard attracts this marauder, though many a chicken taken by him is set down to the fox, farmers having an idea, from his likeness to the ferret, that the rats of their wheat ricks are the means of bringing him there, whereas, though no doubt the polecat would destroy them if he could, he is too bulky to follow them into their holes. The eggs of game and poultry are also greedily sucked by the polecat.

THE STOAT (*Mustela erminea*).

The stoat is intermediate in size between the polecat and the true weasel presently to be described, from which it may readily be distinguished by its bushy black tail. In the engraving opposite this page the stoat is represented in its full winter coat, which it frequently does not assume in this country, long and severe cold being necessary to produce the total change of colour from red to white. The black tip to the tail is never lost, even when the white is as pure as in the foreign skins known as ermine. In England, patches of white to a greater or less extent are generally met with, and in severe winters the stoat is seldom found without more or less indications of the change; indeed, in the north a full white colour is the rule rather than the exception. The summer garb is a reddish brown, the belly being white and the tail tipped with black. The stoat is even more voracious in proportion to its size than the polecat, but, being unable to hold the rabbit or the hare when full of strength, it hunts them down till they are wearied with muscular exertion and mental distress. At last it fastens on the poor frightened and doomed animal, and sucks the life-blood from a wound in the neck, the poor creature some-

times struggling on with the stoat on its back, till it drops from loss of blood. Like the polecat it sucks eggs, and in the breeding season it plays sad havoc with the young of the game birds, as well as with leverets, which it readily finds in the grass by hunting the trail of the doe. Its hole is made in similar situations to that of the polecat, but it has not the same strong scent as that animal. Indeed, it is difficult to distinguish it from an ordinary rat-hole. The habits of the stoat are similar to those of the polecat, allowing for the difference of size and strength.

THE WEASEL (*Mustela vulgaris*).

This, the smallest of the tribe, is only seven inches in length from the nose to the tail. The difference in size alone serves to distinguish it from the stoat, with which it is often confounded. The larger animal has also a more hairy coat, and a longer and more bushy tail, the black tip of which in the stoat is patent enough to enable any one to know it from its congener. The weasel differs little in any of its habits from the stoat, excepting that it is obliged to confine its attacks to the leveret and rabbit, as well as to very young partridges and pheasants, the adult animals of these several kinds being too strong for it, though it is said to have fastened on a full-grown hare and sucked its blood. It has, however, so often been confounded with the stoat that I should suspect in this instance the mistake has been made. It is ready enough at sucking eggs, whether large or small, and instances are recorded of its making up for its deficiency of size by combination, five or six, and even more, weasels having been watched hunting in unison.

THE RAT (*Mus decumanus*).

The rat is so well known as to need no description of its appearance, and its habits also are pretty notorious; but it may be mentioned that occasionally this pest of the farmer is tempted to invade the preserve, and tame-bred young pheasants and partridges are especially likely to be carried off by it. Whenever, therefore, a colony of rats take up

their quarters near game, they should be got rid of as quickly as possible. They are very fond of eggs, as well as of the young birds.

THE HEDGEHOG (*Erinaceus Europæus*).

The hedgehog has been the subject of a great deal of controversy lately on the nature of its habits; one party holding it to be a vegetable eater, and entirely innocent of all noxious propensities, while the other brands it as a destroyer of young game, an egg-sucker, and a cow-milker. That it does occasionally eat birds is easily shown, because it is so often kept alive in large gardens, where it is not starved, and thereby compelled to eat what is offered to it. Here a freshly-killed bird is greedily seized and devoured, while it is only when long deprived of insects and worms, as well as flesh, that the hedgehog will eat roots or vegetables. In a state of nature, I believe, the animal lives chiefly on insects and worms, with the addition of eggs in the breeding season, of which it is particularly fond; but this is only because it is not furnished with weapons for catching birds or quadrupeds. The hedgehog is provided with a grubbing snout like that of the pig, and this is adduced to prove that it searches for roots like the latter animal; but grubs and worms are also found in this way, and it is for them that its nose is at work rather than for the roots of scutch-grass, &c., which it is said to be in search of. The external appearance of the hedgehog is too well known to require description, either pictorial or in type, and I have not, therefore, appended a portrait of it. During the summer it is very active, especially in the evening, when worms come forth, and it may be seen popping about in search of what it can find on the borders of woods and copses, where it remains concealed during the day. It is more or less inactive during the winter, but whether it is a true hybernator is a disputed question. This, however, is a point of little interest to the game preserver, and I shall not therefore enter upon it. That the hedgehog is destructive to game is, I think, clearly established; for whether or not it eats the animals themselves, it no doubt sucks the eggs of pheasants, partridges,

and grouse, wherever it can find them. The female produces from four to six young ones, which at first are naked, but are soon covered with very tender prickles, gradually growing into spines, with which the old ones are defended.

THE EAGLE (*Aquila chrysaetos*)

Is so rare that it will be scarcely desirable to describe its appearance or habits.

THE KITE (*Milvus regalis*),

Commonly known in some districts as the *Glead* or *Gled*. This bird is now becoming very rare in consequence of the war waged against it by keepers, from its tendency to destroy game of all kinds. It may be readily known when on the wing by its forked tail, like that of the swallow, in which it differs from all of its congeners in this country. Every now and then, when in the air, after making a large circle in search of its prey, it will remain stationary, with its wings and tail expanded, and without any of the quivering which is perceptible in the windhover. In England the kite is only met with now in extensive wooded districts, especially those which are not strictly preserved. The annexed figure accurately represents the appearance of this bird when at rest, except in colour, which is as follows:—Beak horn colour; cere and iris yellow; feathers of the head and neck greyish white, streaked with ash brown; feathers of the back and wing coverts edged with reddish brown round a darker centre; primaries black; upper tail coverts reddish brown; feathers of the tail the same, the inner webs being barred with dark brown, and the under surface greyish white; chin, throat, and poll greyish white streaked with pale brown; breast and belly pale reddish brown, each feather having a longitudinal streak of brown; under tail coverts of a uniform rufous white; tarsi and toes yellow; claws black. The females are somewhat larger than the males (the length being respectively twenty-six and twenty-four inches); but the plumage is nearly the same, the heads of the former being somewhat more grey, and the under surface of the body more

decidedly red. The nest is formed of sticks like those of the carrion crow, and lined with feathers, wool, hair, &c. It is usually made early in the spring, the deepest recesses of a large wood, and the fork of a high tree being chosen. The female lays two or three eggs, of a slightly oval form, the long diameter being, as in all the birds of prey, little greater than the short; they measure two inches and two lines by one inch nine lines, are of a dirty white colour, marked on the larger end with a few reddish brown spots.

In its mode of taking its prey the kite resembles the kestrel, not striking it in the air but pouncing on it while on the ground, and in this way being very formidable to ground birds and leverets.

Of the cunning of the kite Mr. Colquhoun gives a remarkable instance. He says, "Kites generally build in the fir forests on the hills, and select a tree with a thin bare stem, often very difficult to climb. I once concealed myself at the foot of a tree where a kite was sitting, in order to shoot it on its return to the nest; for they generally fly off at the most distant approach of an enemy. I was perfectly hid, and after waiting nearly an hour, had an opportunity of witnessing the tact and cunning of the bird. The sun was shining warm upon the nest, or it would most likely not have kept me so long; at last I saw it flying round in very wide circles, which gradually narrowed; it then alighted upon a distant tree, and peering round in every direction chose a nearer, and so on until it came within three or four trees of the nest. It was now within shot; but I had, unfortunately, so placed myself as only to command the nest tree, never doubting that it would alight on this before it settled on the nest. But I was out in my reckoning; as soon as it had tolerably reassured itself, it rose perpendicularly in the air and came down upon its nest like a stone. The manner in which I was concealed prevented my getting a flying shot; so nothing remained but to fire through the nest, which proved a sufficient defence, as the kite flew away and never returned." It will from this be gathered that it is by no means easy to get a shot at the kite, and that the keeper must rely upon the trap to get rid of it.

THE PEREGRINE FALCON (*Falco peregrinus*).

This, also called the *Blue Falcon* (the hen harrier being the blue hawk), is exceedingly destructive to winged game, and on that account, in spite of the exertions of falconers, it will always be condemned to death by gamekeepers in this country. The adult female is about eighteen inches in length, and the male about fifteen. The colours are:—Beak blue, approaching to black at the point; cere and eyelids yellow; iris dark brown; top of the head and back of the neck nearly black, of which colour there is also a spot beneath the eye; back bluish slate or ash colour, the shade becoming lighter as the bird increases in age; all the upper feathers of the body barred with a darker shade of the same colour; primaries brown black, with the inner web spotted and barred with reddish white; throat white, streaked longitudinally with dark brown; breast pale reddish white with transverse bars of the same colour as the throat; under surface of the tail-feathers and coverts barred with dark brown and greyish white; legs and toes yellow, claws black. The young birds have the head and upper surface of the body of a brownish ash colour, the edge of each feather having a reddish tinge. The peregrine falcon builds on high rocks, being extremely rare in England, and not very often met with in the present day in Scotland. The eggs are from two to four in number, two inches long by one inch and eight lines broad, mottled with pale reddish brown. During the breeding season these falcons confine their attacks chiefly to aquatic birds, which are found close to their nests, but at other times of the year they destroy large quantities of grouse and partridges. These are generally pursued and struck on the wing, but Mr. Colquhoun gives an instance which came under his own observation, in which a blue falcon pursued a grouse, put up by him, into the heather, when, he says, “it immediately alighted, searched the heather for a minute, and presently the grouse fluttered out before it. I saw the chase for about ten yards, when they ran behind a hillock, and on my going up to the place, the falcon rose, and there lay the grouse decapitated.” Such an act is, however, an exception to the general habit of the bird, and must not be relied on by the trapper.

THE COMMON BUZZARD (*Buteo vulgaris*),

Is one of the most common of the larger varieties of the hawk tribe, which may be accounted for by the fact that it is addicted to small birds and reptiles, rather than to game; but this is only on account of its laziness, for if they come in its way, the partridge, grouse, leveret, and rabbit, are all pounced upon. Still it is not equal to the blue falcon, kite, or hen harrier in its inroads upon the game preserve. Its flight is somewhat slow and heavy, and it is remarkable for sitting on the topmost bough of a tree for hours, where it watches for the appearance of its prey, and on seeing it darts down upon the ground, picks it up, and carries it back to its perch to devour it. The length of the buzzard is about twenty-one inches, the female being a little over, and the male somewhat under, that size. Beak bluish black, approaching to black at the point; cere yellow; iris also yellow, but varying in shade from buff to orange brown; upper part of the head and cheeks pale brown, streaked with a darker shade; all the upper parts of the body, tail, and wings, dark clove brown, the tail feathers being barred with a lighter shade, and the feathers of the other parts being edged with light brown; wing primaries brown black; chin and throat white; breast, under wing coverts, belly, and thighs, greyish white, spotted, and streaked with brown; under tail coverts white; under surface of tail feathers greyish white, barred with wood brown; legs and toes yellow; claws black. The nest is in Scotland usually formed on rocks, or on the high banks of rivers, and is composed of twigs and heath, lined with wool or some similar substance. In England, the fork of a tree is generally chosen, or an old nest of some other bird—the materials used being twigs and woollen substances for lining. Here the female lays from two to four eggs, two inches three lines in length by one inch ten lines in breadth, of a dirty white colour, slightly spotted with pale brown.

THE MARSH HARRIER (*Circus aeruginosus*),

Also called the *Duck Hawk*, *Harpy* and *White-headed Harpy*, comes next to the buzzard in size, but is to be known

from that bird at once by its more elegant shape, and by its taper and naked legs. The plumage of the harrier is remarkably soft, like that of the owl, which it also resembles in having a frill more or less distinct round the face. All the harriers vary in colour greatly, and on that account it is difficult to describe them. The males are particularly subject to these changes, becoming more or less ash grey as they grow older; while the females retain their original shade of reddish brown. The marsh harrier is larger than the hen harrier, presently to be noticed, and is met with—as the first half of its name implies—on low grounds, such as the fens of Cambridge and Lincolnshire, which it beats like a dog—whence it has derived its second appellation. It may be seen either flying slowly and smoothly near the ground, or sitting on a stone or low bush, seldom on a tree, looking out for its prey, which it strikes on the ground. It is very voracious, and devours young rabbits, leverets, reptiles, and the young of the game birds. The length of the marsh harrier averages twenty-one inches—the female, as usual, being larger than the male. In the adult male, after the third moult, the beak is bluish black; cere and iris yellow; top of the head and neck, as well as the cheeks, yellowish white, tinged with reddish brown, and streaked with dark brown; feathers of the upper parts of the body dark reddish brown, edged with a lighter shade; primaries brownish black; secondary and tail feathers ash grey; tarsi long, slender, and of a yellow colour; toes yellow; claws black. In subsequent moults the wing coverts and tertials become more or less of an ash grey; wing-primaries slate grey; chin and throat nearly white; breast rufous, streaked with dark brown; belly, thighs, and under tail-coverts reddish brown. In the young birds, before moulting, the whole bird is of a chocolate brown, each feather being tipped with a lighter colour. In the second year, the head, neck, chin, and throat become a dull yellow, with an occasional patch of the same colour on the point of the wing. The nest is placed on the ground, in long grass, fern, or rushes, or sometimes in heather or furze. It is formed of small sticks or rushes, and contains three or four eggs, white in colour, pointed at one end, two inches and one line in length, and one inch six lines broad.

THE HEN HARRIER (*Circus cyaneus*).

The male of this species is known as the *Dove Hawk*, or *Blue Hawk*; while the name *Ringtail* is applied to the female in many parts of the country. The origin of the generic term "Harrier" has already been alluded to, and the specific prefix is given from the fondness for chickens which this bird displays, worrying the hen for them continually, and hence called the *Hen harrier*. Like the marsh harrier, it is fond of low ground, and it is especially likely to be met with on lands reclaimed from the sea, but still so barren as to be given up to ling and rushes. Here it may be seen hunting near the ground for reptiles, or for leverets, which are partial to such situations; and for this reason the bird is not left unmolested by the keeper. The male and female vary in colour and size, and for a long time they were considered to be two distinct species. Hence they must be separately described.

The adult male or Blue Hawk is about eighteen inches in length; colour as follows: Bill bluish black; cere and iris yellow; lore covered with black hair, radiating from a centre and hiding the nostrils; head, neck, chin, throat, and upper parts of the body and tail ash grey; primaries brown black, not reaching to the end of the tail; breast and belly bluish white; thighs and under tail coverts white; under surface of tail pale greyish white, slightly barred; legs and toes slender and yellow; claws black (see fig.). *The young males*, up to the second moulting, are brown, and similar in colour to the female, presently to be described, but of smaller size.

The adult female, known as the *Ringtail*, is twenty inches long; bill black; cere greenish yellow; iris reddish brown; crown of the head and nape of the neck umber; a narrow collar of reddish brown round the neck; a light-brown streak over the eye; the hairy disc round the bill of a mixed brown and white; upper parts of a uniform umber brown, the smaller wing coverts being edged with reddish brown; primaries brown black; central tail-feather umber brown, those on the outside being dark brown, barred with reddish brown; all the under parts of a reddish buff colour, each feather having a central spot of reddish brown; under

surfaces of middle tail-feathers barred with black and dull white, those of the outer feathers being greyish white, also with darker bars; legs and toes yellow; claws black. The nest is built on the ground, of sticks or rushes, and coarse grass; it contains four or five eggs of a white colour, but more or less slightly tinged with blue, one inch eight lines long by one inch four lines broad. The males occasionally sit as well as the females.

MONTAGUE'S HARRIER (*Circus cineraceus*).

This rare variety of the harrier is known as *the Ash-coloured Falcon*, and may be distinguished from the hen harrier by possessing greater slenderness of body and length of wings, which slightly extend beyond the tail. In other respects and in its habits it closely resembles its congener, and it is therefore unnecessary to describe it.

THE SPARROW-HAWK (*Accipiter nisus*).

This is a short-winged hawk, very common in the wooded districts of England, Ireland, and Scotland. It is a remarkably bold bird, and a dangerous enemy to young game of all kinds, having been known to strike a partridge as big as itself.

The adult male measures twelve inches in length. Beak blue; cere greenish yellow; iris yellow; all the upper parts of head, neck, and body of a rich brown, with a tinge of grey in old birds; tail greyish brown, with three bars of dark brown; under parts light reddish brown with transverse bars of a darker colour; legs and toes yellow; claws black. *The female* is fifteen inches long; beak bluish horn colour; cere and iris yellow; upper parts of head, neck, and body brown, with whitish spots; primaries and tail light brown, barred with darker brown; all the under parts greyish white barred with brown; legs and toes yellow; claws long and black.

The young males resemble the female excepting in size, and in having a reddish brown edge to the feathers of the back and wing coverts. This bird seldom builds its own

nest, but takes possession of that of the crow or jay, in which the female lays from four to five eggs of a pale bluish white, blotched with dark red and brown, one inch seven lines long, and one inch four lines broad.

THE HOBBY (*Hypotriorchis subbuteo*).

This is a miniature peregrine falcon, and is only a summer visitor, appearing in this country in April, and leaving in October. Its habits, however, do not resemble those of its larger likeness, inasmuch as it prefers woodlands in the interior of the country. It is not very destructive to game, preferring smaller birds, such as the lark, which it is so fond of pursuing as to have obtained the name of *alaudarius*. It also feeds on the larger *coleoptera*. The hobby is about twelve to fourteen inches in length, the female being the larger, but not otherwise differing from the male. The bill is bluish black; cere greenish yellow; iris dark brown; upper parts of the head, neck, and body greyish black, each feather being edged with dirty white; wing feathers black, edged also with dirty white; two middle tail feathers greyish black; the outer ones slightly barred with a lighter shade; chin and sides of the neck white; cheek black; under parts yellowish white, streaked with brownish black; under tail coverts white; legs and toes yellow; claws black.

In young birds the plumage has a reddish tinge. The nest is built in a high tree, of twigs, but like the sparrowhawk, it often takes possession of that belonging to another bird. It lays three or four eggs of a dirty white, speckled with reddish brown; length one inch eight lines, breadth one inch four lines.

THE MERLIN (*Hypotriorchis æsalon*).

This is the least of the British hawks, and is remarkable for its beauty and courage, a male not more than six ounces in weight having been known to kill a partridge more than double its size. Curiously enough, while the hobby is only a summer visitor, this bird, which closely resembles it, comes over to us from beyond the seas in the winter, though

there are also a few pairs which breed in this country, on the northern moors. In the south it is extremely rare in the summer, and indeed it is not commonly met with south of Yorkshire at any period of the year. Its usual food is composed of small birds; but when pressed by hunger, it will attack the partridge, (especially the young ones when it has its own brood to supply.) but as it does not strike on the ground, it is seldom that the opportunity offers. It does not therefore do much harm to game, and the lovers of natural history as well as of hawking might well be spared the loss of this beautiful bird at the hands of the keeper. Still there is no doubt that occasionally it will take a partridge or grouse; but while the fox is allowed to have his pheasant occasionally, surely the falconer might be permitted to have an exemption in his favour, when the injury done is so slight. In Northumberland and Cumberland merlins are plentiful enough, and young birds may be obtained in almost any numbers at 5s. to 7s. 6d. a-piece. In size this bird is slightly less than the hobby, measuring from ten to twelve inches long. An old male has the beak blue, with a blackish tip; cere yellow; iris dark brown; crown blue grey streaked with dark brown; a collar of reddish brown passing from the cheeks round the neck; back rich bluish grey, each feather having a dark brown shaft; primaries rich black; tail bluish grey, with three faint bands for the basal two thirds, the end being black tipped with white; chin and throat white; under parts of body pale reddish brown streaked and patched with darker brown; legs and toes yellow; claws black. *The female* has all the upper parts of head and body of a dark liver colour, the edges of all the feathers being faintly tipped with red; tail brown, with five narrow bars of wood brown; under surfaces whity brown with darker streaks and patches; in other respects like the male. *The young males* resemble the females, except in size. They, as well as the young of the other sex, are called *stone* falcons in Wales. The nest is built on the ground, with a few bents of grass only. The female lays four or five eggs mottled with two shades of reddish brown, one inch seven lines in length by one inch three lines in breadth.

THE KESTREL (*Tinnunculus alaudarius*).

The *Kestrel* or *Windhover*, also called the *Stonegall* or *Standgale*, is one of the most graceful birds known in this country, and may be distinguished from all others by its habit of suspending itself over some fixed point with outspread tail and its head always to windward, accompanied by a peculiarly quick motion of the wings, from which it has derived its name of "Windhover" and "Standgale." While in this position it is watching some mouse, or possibly a young leveret, which it will no doubt occasionally take; but for one of these which it seizes, it will probably kill a hundred mice. I have opened the stomachs of scores of these birds, and have never yet seen the remains of a leveret. Once, it is true, I came upon a portion of what looked like the skin of a young rabbit, but it might have been that of a rat, as I did not wash and dry it. At all events it had not the colour of the leveret. A large proportion of the contents was composed of mice, with a very few small birds of various kinds. Still, it cannot be said to be to the game preserver *sans peur et sans reproche*; for it has neither courage enough boldly to attack game whenever it comes in its way, nor can it always resist the temptation afforded by a delicate leveret which it may espy in the grass when in search of mice. Selby says that they feed on cockchafers during their season, and Montague affirms that he never found any feathers in their stomachs; but I certainly must give my evidence in favour of their occasionally killing small birds as I have mentioned above. A large proportion of those I have examined have been young ones barely fledged, and perhaps at that season the parent birds may be more rapacious than at other seasons, and may also be able more readily to strike young larks and other ground birds in their favourite method by suddenly stooping on them. The kestrel is universally found throughout the United Kingdom. Its length is from thirteen inches in the male to fifteen inches in the female. The former has the beak blue; cere and eyelids yellow; iris dark brown; crown, cheeks, and nape of the neck ash grey streaked with dusky brown; upper parts of body of a rich fawn colour, each feather spotted with black on the extreme point; wing

feathers greyish black, the edges of a lighter shade ; tail ash grey, with a broad black stripe near the end, which again is tipped with white ; under parts whity brown, the breast being streaked and the belly spotted with brown ; thighs and under tail coverts of a pale fawn colour, also streaked ; under surface of tail whitish grey, showing slightly marked transverse bands, besides the black terminal bar ; legs and toes yellow ; claws black. In the *female* the crown is a rich fawn with dark stripes ; upper parts, including the tail, all reddish brown, with bars of bluish black, the tail having the black bar tipped with white, as in the male ; the whole under surface paler than in the male, in other respects the same. The *young males* resemble the females till after their first winter. The kestrel builds in high rocks or old towers, but frequently it takes possession of an old crow's or magpie's nest. It lays four or five eggs one inch seven lines long by one inch three lines, mottled with dark reddish brown on a pale reddish white ground. They are usually hatched about the 1st of May. The illustration represents an adult male.

THE WHITE OR BARN OWL (*Strix flammea*).

Mr. Waterton has taken this bird under his special protection, and has shown that its food is almost entirely composed of young rats, mice, shrews, small birds, and insects, as well as occasionally fish. That it does occasionally capture game is true enough, but such a misdemeanour is exceptional. Still there is no denying the fact that it is sometimes caught, *flagrante delicto* ; but the services which it renders to the farmer ought to make the game preserver pass these peccadillos over. Like the kestrel, the little harm which it does is compensated for a hundredfold by its good deeds, and the keeper who shoots it, to the annoyance of the farmer, will lose far more than he will gain. The barn owl is common enough in England and Ireland, but it is not so frequently met with in the north. When it does give utterance to any noise, which is but seldom, it screeches rather than hoots, like the tawny owl, but still the note may be called a hoot by some people. When in search of food it skims with noiseless wing the fields around its abode, and

when its nocturnal eye spies a luckless mouse it hovers over it in the most silent manner, with its legs hanging down, and rapidly alights on its prey, which it seizes in its claws and bears away. Should this bird come abroad in the daytime, it is beset by thrushes, blackbirds, swallows, and other small birds, which give it no peace till it retires to some spot out of their sight. The white owl comes out earlier than the brown, and may frequently be seen in the twilight hour hunting for mice. In the *old male* the length is fourteen inches; the beak is almost white; iris bluish black; face white, the edges being tipped with brown, and having a rusty stain under each eye; crown and nape of neck pale buff, spotted with black and white; upper parts of body darker buff, speckled and mottled with grey, black, and white; tail feathers of a pale buff, with five grey bars; all the under parts snowy white; tarsi covered with white, fanlike feathers, which also extend to the upper surface of the toes; claws brown, the middle one being slightly serrated. The wings are longer than the tail, and the fibres of which their feathers are composed not being all of the same length, the flight is rendered noiseless. The *females* resemble the males, except on the under surface, which is of a less snowy white, and sometimes even of a pale fawn colour. The nest is built in a barn, old malt-house, church tower, or any old ruin covered with ivy. The female lays from three to seven, or even eight, eggs, of a white colour, one inch six lines long by one inch three lines. It is remarkable for beginning to sit as soon as one egg is laid; so that the young are hatched on consecutive days, and as they grow up are of all sizes.

THE TAWNY OR IVY OWL (*Strix stridula*).

This bird is still more nocturnal in its habits than the barn owl; but nevertheless it is far more destructive to game, feeding, according to Yarrell, "on leverets, young rabbits, moles, rats, mice, birds, frogs, and insects," as well as "occasionally on fish," like its white congener. Its wings are not so long as those of that bird, nor is its flight so rapid and buoyant, though quite as soft, noiseless, and spectre-like.

It is thus, as remarked by Mr. Colquhoun, "less formed for beating a large extent of country for mice, and must often content itself with promiscuous feeding." Elsewhere he remarks: "They (the white owls) are evidently more expert mousers than the brown, which may in part account for the latter's destruction among young game. I recollect nearly all the young pigeons in my father's dovecot being devoured by a pair of brown owls." This character, coming from a writer who is evidently prepossessed in favour of owls, and who accuses a keeper of shooting a colony of brown owls as a blind for laziness, is certainly somewhat condemnatory of them, and probably most game preservers will think themselves justified in ordering their destruction, though there is no doubt that, as in the case of the white owl, they are excellent friends to the farmer from destroying mice and rats. The tawny owl is common in all wooded districts where game is not very strictly preserved, and inhabits thick woods, especially where there are evergreens. Its note is a loud and melancholy hoot, seldom heard during the day. The length of the male is fifteen inches, the female being a trifle longer. The former has the beak of a pale-brown colour; iris dark blue; face greyish white, edged with a line of dark brown; upper parts ash grey, mottled with a rich brown in two shades, and having a line of white spots on the edge of the scapulars, wing-coverts and primaries barred with white and brown; tail barred with brown of two shades; under parts of body greyish white, mottled and streaked with brown; under tail-coverts white; legs and toes clothed with short, pale grey hairs; claws pale brown colour, tipped with brown. The females are of a deeper tawny colour; the young males resemble the females till their second moult. These birds build in the ivy covering any old ruin, or in the hole of a tree similarly clothed, or if these are not to be found they take possession of an old magpie's nest, which suits them from being covered in. The eggs, to the number of three or four, are white, one inch ten lines in length by one inch and a half. They are hatched in April or early in May, and the young birds are a long time before they can fly, perching on the boughs near the nest, where they are fed by both their parents.

THE RAVEN (*Corvus corax*).

The Raven is now becoming rare in this country, being destroyed by the shepherds from its fondness for lamb, and by the keepers on account of its propensity to take the young of all species of game, as well as the eggs of game birds, of which it is particularly fond. It also devours reptiles, insects, carrion of all kinds, and even grain when animal food is not to be obtained. It is chiefly found on high mountain rocks, or on the seacoast, in extensive woodlands, or open plains, where its strong sight and keen powers of scent render it difficult to approach. The length of the *male* is twenty-four to twenty-six inches; beak black; feathers of the nostrils an inch long; iris brown and grey; plumage black, with a gloss of purple; legs, toes, and claws, black. The *female* is smaller than the male, and her feathers, like those of young birds, have less brilliancy and lustre. Ravens breed early in the year, beginning to build in February. The nest is placed on the highest tree in the neighbourhood, on the fork of a branch. It is formed of sticks, lined with wool and hair. The eggs are four or five, two inches long by one inch four lines. The ground colour is a pale green, spotted and mottled with olive green and brown. Ravens keep in pairs all the year round.

THE CARRION CROW (*Corvus corone*).

This bird resembles the raven in all but length, which is about eighteen to nineteen inches. It is also called the *Gir Crow* and *Flesh Crow*. Wooded countries are their chief *habitat*, and here they are constantly on the look-out for dead horses, cows, or sheep, in default of which they destroy weakly lambs, or capture young leverets and rabbits, as well as the young of the winged game. Like the raven also, this bird breeds early, the nest being placed on the forked branches of a tree, and made of the same materials. The eggs are four or five, of a pale bluish green mottled and speckled with ash colour and brown; length, one inch eight lines; breadth, one inch two lines.

THE HOODED, OR ROYSTON CROW (*Corvus cornix*).

The hooded crow, otherwise called the *ash-coloured crow*, is even more mischievous to game than the carrion crow. It is very common in the west and north of Scotland, where it breeds; the inroads made upon the species by the incessant attacks of the keepers being made up by fresh migrations from Sweden and Norway, which come over in the autumn. In the south they rarely breed, but make their appearance on the eastern coast with the woodcocks, and are particularly numerous about Royston, whence they are named. Their habits are similar to those of the carrion crow. The length of this crow is twenty inches; beak strong and shiny black, half covered with black feathers; head, cheeks, throat, front of neck, wings, and tail of a brilliant black; nape of the neck, back, rump, and under surface a smoke grey; legs, toes, and claws black. These birds breed early in the year, making their nests in trees and rocks on the sea-coast, composed of sticks, lined with hair or wool. The eggs are four or five in number, the ground of a light green mottled with greenish brown; length one inch ten lines—breadth one inch three lines.

THE JACKDAW (*Corvus monedula*).

The jackdaw is found all over England wherever there are high buildings for it to nest in. It is not accused of destroying live game, but it has occasionally been known to suck eggs, and hence it is proscribed by the strict school of gamekeepers. Its haunts, however, are so different, and the benefits it confers upon the farmer by its insectivorous appetite are so great, that I cannot help thinking it should be allowed to escape. Of course, if a particular jackdaw is known to be an egg-sucker he must suffer the penalty, but an indiscriminate massacre of these birds is scarcely desirable.

The length of the jackdaw is fourteen inches; beak black and half covered with feathers; iris greyish white; crown black; nape of the neck and shoulders dark grey; rest of the body and wings black; bluish on the wings and rusty below; legs, toes, and claws black. The nest is built of

sticks, and in it are laid five or six eggs, of a pale bluish white spotted with clove brown and ash colour; length one inch seven lines—breadth one inch.

THE MAGPIE (*Pica caudata*).

The appearance of this lively bird is too well known to need description, and being a sad destroyer of game, it is, as far as possible, exterminated from his district by every keeper. All kinds of animal food will be eagerly devoured by it, whether dead or alive, from the dead horse to the cockchafer. Young poultry and game birds, as well as their eggs, are especially sought after; and leverets as well as young rabbits are titbits which the magpie cannot resist. These birds pair all the year round; the nest is curiously devised, the whole structure being interlaced very strongly with sticks, leaving only an aperture at the side for the birds to go in and out. This framework is lined with clay, inside which is a layer of roots and grass. The nest is sometimes made in high trees, and at others in low bushes, especially of the thorn tribe; and this difference in the nesting-place has been attempted to be made a means of splitting up the species into two varieties. The eggs are six or seven in number, of a pale bluish white ground spotted with olive brown and green, and also with ash colour. Their length is one inch and four lines—breadth one inch.

THE JAY (*Garrulus glandarius*).

The jay comes last in the list of game destroyers, and, like the jackdaw, is chiefly obnoxious to the keeper from its egg-sucking propensities, though it will no doubt occasionally seize a very young partridge or pheasant when it has the chance. Its food is chiefly of a vegetable nature—acorns, beech-mast, and garden fruits being the most attractive to it. It inhabits thick coverts, and is seldom found in the open. The nest is built of sticks lined with grass, in a low tree or high hedgerow. The eggs are five or six, of a yellow white thickly spotted with light brown; length one inch four lines—breadth one inch. The adult bird is from thirteen to fourteen inches

long; beak black; iris pale blue; forehead and crown greyish white, the feathers forming a crest capable of being raised at pleasure; nape and back of a cinnamon brown; wing coverts barred with black, white, and pale blue across their outer webs; primaries dusky black with the outer edges white; secondaries black, each having a white patch on the outer web; the last tertials of a rich chesnut colour; upper tail coverts white; tail black; chin white; under parts buff colour; legs, toes, and claws brown. The colours of the female resemble those of the male.

TRAPS AND TRAPPING.

Before entering upon a consideration of the various modes of taking vermin by traps, it will be necessary to describe the details of their mechanical construction, but more particularly the principles upon which they are framed. With the exception of the common wire or snare, which is of little use in reference to vermin, all traps may be divided into two sets—1st, those which take the animal alive, of which the box or hutch-trap is the type; and 2ndly, those which catch it between two jaws, which fall together either by the force of a spring or by gravity, when a trigger is moved—as for example, the common gin or steel trap, the figure of 4 trap, the weasel trap recently described in the *Field* by “High Elms,” &c. &c. The live traps all act upon the same principle as the dead ones—that is to say, by the pulling of a trigger, to which is generally fastened a bait; but in their case the result is to cause one or two trap doors to fall, which enclose the animal within a space from which it cannot escape. Both may be set baited or unbaited—in the latter case, being placed where the animal sought to be taken is likely to come, and both being so concealed as not to awaken suspicion. My own opinion is, that the hutch trap and the gin are sufficient for all purposes, and that all dead traps are inferior to the latter for this plain reason, that they act in exactly the same way by a plate and trigger, and have the serious objection that they cannot be concealed. Wherever a figure of 4, or a “High Elms’” trap can be set, the common gin can be set far better, and more safely too, for it may always be

placed out of reach of game, whereas they cannot. I shall therefore chiefly allude to these two, commencing with

The gin or steel trap, which is made of various dimensions, according to the kind of vermin for which it is intended. Three sizes, however, will suffice for most purposes, the smallest one being four inches from jaw to jaw when set, the second six, and the larger one seven or eight—the latter being big enough to hold any kind of vermin in the list already given. These traps should be obtained from a good maker, and not from any chance ironmonger, who sells the cheapest he can purchase in Birmingham. The springs should be carefully tempered, and neither too strong to allow of the trap being set “ticklish,” or so weak as to admit of the escape of the animal whose leg is caught. They are made with plain jaws, as well as with teeth, the former being preferred by some keepers, but requiring very strong springs, they are not so readily set with proper delicacy. My own experience is in favour of *short* teeth. Gins may be set on the ground, or on posts or high stones. In the former case they must be entirely concealed; and in doing this artistically the good keeper may be known from the ignorant pretender. The plan is as follows:—First, lay the trap on the ground, then mark the outline of it, allowing half an inch clear all round; cut away the turf to this pattern, and in the centre dig a hole deep enough to receive a strong peg and the chain which fastens the trap to it, which will thus be entirely concealed; drive in the peg, arrange the chain neatly upon this, and in the channel for the spring; and then set the trap in its place, temporarily propping up the plate by a piece of twig, which can finally be withdrawn by a string; take care so to cut away the turf that the jaws are only just below the level of the ground. Having done this, cut a very thin slice of the turf which was removed to make way for the trap, leaving little more than the grass itself, with a ragged edge, and lay this gently on the plate, and withdraw the prop; then cover the spring in the same way; and lastly, put some more shreds of grass or leaves over the jaws themselves, but in such a way that the former will not be caught between the teeth when the trap is sprung. When the keeper can do all this so neatly that the trap cannot be

discovered by the eye at a two or three yards' distance, and yet will be sprung by half an ounce weight being placed upon the plate, over and above what it has already, and without leaving anything between the jaws, he may be considered a master of his craft. All this should be done with strong leather gloves on the hands, and with as little breathing over the trap as possible. The object of these precautions is to avoid leaving any scent behind, which might alarm the vermin, who are always suspicious of any place

FIG. 97. HAWK TRAP.

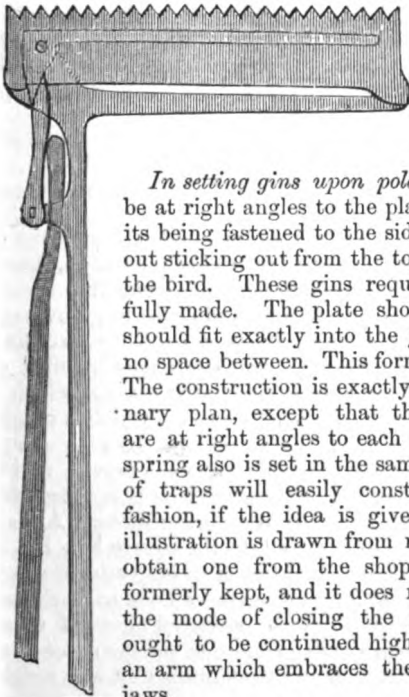

where they have reason to believe man has been at work. There are various positions in which this trap should be set, which will be presently described.

In setting gins upon poles the spring should be at right angles to the plate, so as to allow of its being fastened to the side of the post, without sticking out from the top in a way to alarm the bird. These gins require to be very carefully made. The plate should be circular, and should fit exactly into the jaws, so as to leave no space between. This form is shown in fig. 97. The construction is exactly similar to the ordinary plan, except that the plate and trigger are at right angles to each other, and that the spring also is set in the same way. Any maker of traps will easily construct them in this fashion, if the idea is given him. The above illustration is drawn from memory, as I cannot obtain one from the shop where they were formerly kept, and it does not exactly indicate the mode of closing the jaws. The spring ought to be continued higher, and should have an arm which embraces the lowest part of the jaws.

The *Box-trap* or *Hutch-trap* may be made by any village carpenter, and I shall therefore give full directions for its construction. First make an oblong-square box open at each end, three feet six inches long and eight or nine inches square inside. (See fig. 98.) There should be a second bottom

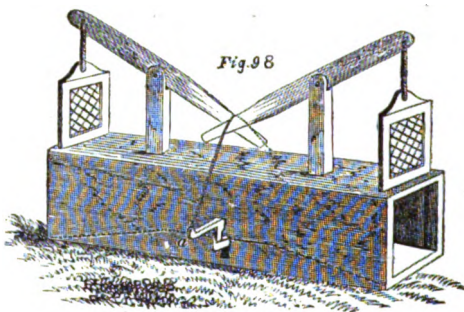

VIEW OF BOX TRAP SET.

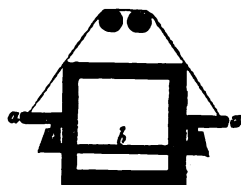

SECTION OF DITTO.

raised to the level of the dotted line, and in the centre of this a square hole should be left to receive the plate *b*, shown in section at fig. 98, and in plan, fig. 99. Next fit a sliding door at each end, running easily up and down in grooves cut for the purpose, and suspend these by cords to two long levers, as shown in the figure. The doors may be solid, or of wood pierced with holes, or of strong wire-work, which is the best, as the animal, whatever it may be, which is caught is always inclined to work away, with a view to escape wherever it sees light, and thus overlooks the crevice at the bottom of the door, which in the solid plan is apt to draw its attention and to lead to the door being lifted. A plate of wood is then cut to fit loosely into the square hole left in the false floor, and to it are fixed two arms projecting through slits in the sides of the box, and having a hook at each end, as shown in fig. 98 at *b*. Two \lrcorner -shaped pieces of wood, *a a*, fig. 98, and a cord passing from one to the other over the levers complete the trap. It is manifest that any weight on the plate *b*, which is only delicately suspended by the two pieces *a a* will detach it from them; when the cord is libe-

rated which holds down the two levers, and the doors at once fall by their own gravity. The construction of this box is the same in principle as the common box-trap, the only difference being that the plate in the ordinary plan is supported at one end on a strip of wood, and there is only one L-shaped piece. But in the mode which I have here indicated the plate is much more ticklish, and the foot of a weasel or rat placed on any part of it will be sure to disengage the cord and to cause the doors to fall. To set it, proceed as follows:—Have two small wedges which fit loosely into the openings beneath the arms of the plate at *a*, insert them, and so prop it up, depress the two levers, and drop the L's into their places, as shown in fig. 98; then simply lay the baits without any fastening, one on each side, and about two inches from the plate, as at *c c*, fig. 99, which is a ground-plan of

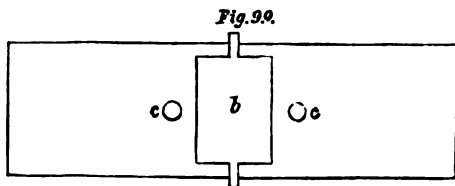

GROUND PLAN OF BOX TRAP.

the box; and lastly set the L's ticklishly, withdrawing the two props one at a time, and leaving only just sufficient of the two surfaces in contact to keep down the levers and support the plate. The hooks at the end of the plates should be pointed so that even if the plate is only depressed at one edge, they will slip from the L, and so disengage themselves from it. The baits should be small, and are placed one on each side the plate, so that a weasel or polecat will devour one, and then be tempted fearlessly to cross the plate to the other, in doing which it is caught by the doors falling. The great advantage of this trap is that it does not kill or even injure in the slightest degree the animals which it captures, so that if a rabbit or hare enters it, no harm is done, for the door is at once raised, and it escapes. These box-traps are set either in the natural runs frequented by the stoat or

weasel, &c., or else in others purposely made, concealing the entrances by placing small branches of thorn, privet, &c., round the box, and leading the animals up to it by gradually narrowing the distance between them. A dead rabbit may be dragged for some distance along the ground up to the end of the trap, and then leaving a little of its blood on the ground and sprinkling more just inside the box, the rabbit may be removed, unless a part is used for the bait; but if a weasel is to be taken, barely an ounce of the flesh or of the liver should be placed on each side the plate of the trap, or the animal's hunger will be sufficiently satisfied to make it suspicious, and the fatal drop will not be passed.

The figure of 4 trap is composed of a large square piece of stone or slate, propped up in a peculiar manner with three pieces of wood, which are arranged in the shape of a 4. In examining this figure it will be seen to consist of a perpendicular limb or "upright," of a horizontal one or "stretcher," and of a short "slanting stick," as the third is called. The upright is usually cut about half an inch wide, shaved to a thin edge at top, but "High Elms" recommends it to have a forked foot to keep it from twisting, and a notch in it to prevent the stretcher slipping down. The slanting stick has a notch cut in it half an inch from its upper end, to receive the top of the upright, while its lower end is shaved off to fit into a notch in the upper surface of the front of the stretcher. Lastly, the stretcher has this notch in front and another notch cut in its side, by which it is caught by the upright and held in its place. A bait being tied to the external end of the stretcher, and a stone placed so that it will lie flat on the ground, the whole is ready for setting, which is effected as follows:—Raise the stone and support it by the notched end of the slanting stick held in the left hand, the notch itself looking downwards, then place the upright with one end on the ground and the other in this notch, and let it carry the weight of the stone, which will have a tendency to tilt up the "slanting stick," still held down by the left hand; finally, hitch the middle notch of the "stretcher" in the "upright," with its front notch facing upwards, then bring the lower end of the "slanting stick" down to this front notch, drop it in, and the trap is set. Of course it

requires that each part shall be carefully adapted to the others, but when the trap is seen set, it will be readily understood, practice being, however, required to set it properly. I quite agree with "High Elms" that the footed upright is an improvement, but I am inclined to doubt the advantage of the double notch between the upright and stretcher. I have tried both, and I cannot find that there is any great superiority in his plan, but perhaps, though I have exactly followed his directions as given in the *Field*, I may have omitted some point of practical importance. In setting the figure of 4 trap, the height of the upright and the size and weight of the stone will be proportioned to the animal for which it is set. I do not like the trap myself, as it cannot be concealed so well as the steel trap, and indeed has no advantage except its cheapness. Dozens of them may be set in the woods, and if stolen, little harm is done, as the cost is barely a penny a piece, if made in large numbers. I have also known pheasants caught by the head and killed in them, the flesh with which they are baited being often attractive to tame-bred birds, which usually are fed with more or less of it in their rearing.

A very complicated weasel-trap was described in the *Field* of the 29th of May, 1858, by "High Elms," as having been recently invented by him. Like the last, it acts by suffocation, but instead of the force of gravity a spring is used. As, however, the inventor is about to publish a little *brochure* on vermin trapping, I will not poach on his manor by minutely describing it here.

The various kinds of vermin are best trapped as follows :—*Cats* and *martens* are readily caught in the steel-trap set as follows : get some thorns and plant them so as to leave a vacant space of about a yard in diameter, with two entrances to it just wide enough to admit the vermin. In these set the steel trap in the mode described at page 430, so as to be made perfectly invisible either by grass or leaves. Then, in the centre of the open space fasten a live pigeon, chicken, or any other bird, by tying it to a peg with a short string, or if a live bird is not procurable use a dead rabbit, but in the latter case a trail must be laid up to it. The living bait will struggle or move sufficiently to attract the notice of the

vermin whose sensitive ears are always on the look-out for sounds. The *two* openings are made because all animals are more afraid of a *cul de sac* than of entering a clear passage, their instinct or reason telling them that they are more safe with two modes of escape than one. Hares and rabbits may *possibly* be caught in these traps so set, but a living animal will scare them, and if a dead one is used and any putrid flesh which would attract the vermin is rubbed against the thorns at the entrances to the central space, the hares and rabbits, as well as pheasants, will be deterred from entering it. If it is particularly necessary to avoid all risk of catching any kind of game, the box-trap may be used, but for a cat it should be fully four feet long and nine inches square. If set it is well to conceal it by planting thorns all round it, and spreading them out from the mouths also to make the openings look less suspicious. The figure of 4 trap is useless for these animals, which are strong enough to throw the stone off unless it is of very unwieldy size.

If the *fox* is to be trapped, which is necessary in some countries where fox-hunting is quite impracticable, two or three large steel traps are set in the same way as for the cat, but with a central opening of at least five or six feet diameter. A live fowl or duck makes the best bait, particularly the latter, which will keep up an incessant quacking and attract the fox from a long distance. Next to these is a half-buried, dead rabbit or hare in a half-putrid state, which will by its scent attract the fox, especially if a trail is laid up to it.

Polecats, stoats, and weasels may be readily taken in the box-trap if it is nicely set and carefully concealed. In thick hedges it may be placed in the meuses made by the hares, which are sure to be used also by these vermin, and even without any bait it will often take them. But by fixing one in a dry ditch and concealing its mouth with thorns in such a way as to keep out hares, while the opening is large enough to admit the stoat or weasel, the former are allowed to escape. Some keepers raise the trap-door only half or three-quarters of the way, but this plan is not so good as reducing the opening by thorns. The polecat is said to raise this door himself, but if it is made of wire, as shown in the plan at

page 432, he will never make the attempt, but will work away at the wire itself where the light is clearly seen. Steel traps may be set in artificial runs constructed as for the cat, but of smaller dimensions, the trap itself also being of the reduced size, or they may be placed in short pipes or drains cut through the bank of a hedge, which the weasel and stoat will be sure to search. Lastly, the figure of 4 trap may be used for the weasel or stoat, but is scarcely heavy enough to kill the polecat, which is very strong and tenacious of life. It should always be remembered that steel-traps set for these animals can be covered in either by earth or thorns, so as to be quite safe from any kind of game larger than the diameter of their own bodies.

The rat is the most difficult of all the four-footed vermin to trap, but when it takes to the field it is not so cunning as in the house. A couple of gins set at the entrances to a space constructed of thorns, and containing a live animal tied to a peg, will be more likely to take the rat than if baited with a dead bait, for the presence of a living being other than his natural enemies, gives confidence, and he will enter boldly a space constructed for his capture, from which he would otherwise carefully keep away. When rats occur in situations where they are likely to take game, they may generally be ferreted, which is the most fatal method of destroying them, or they may be poisoned in their holes when there is no danger of injuring anything else. If, however, they are in any numbers the assistance of a *really useful* professed rat-catcher will always be desirable, as he will do more in two or three nights than an ordinary keeper will effect in a month.

Compared with four-footed vermin, the birds are ten times more difficult to trap, and their habits must be minutely studied in order to obtain their presence at the keeper's grand show. Two or three leading features must be well noted. Thus, some feathered vermin strike their game on the ground; others will not touch it there. Some will take a dead bait; others will not go near it. Again, the egg of a barn-door fowl is very attractive to all egg-destroyers, while to the *Falconidæ* it is perfectly innocent of all temptation. There are certain birds which habitually perch on high posts,

and this is taken advantage of to place an unbaited gin there, into the jaws of which they are apt to drop their legs. But all are strongly attached to their young, and, cruel as it seems to be, this instinct is the keeper's strongest aid in obtaining possession of them. It will, therefore, be desirable to include under these heads all the various kinds of winged vermin, so that in setting any particular trap or bait the keeper may know which of his enemies is likely to be taken by it.

1. *Birds which strike their prey on the ground.*—The eagle, the kite, the kestrel, the sparrow-hawk, the buzzard, the harriers, the owls, the raven, the carrion crow, the hooded crow, the magpie.

2. *Birds which only take it on the wing.*—The peregrine falcon, the hobby, the merlin, the sparrow-hawk.

3. *Birds which will take a dead bait.*—The kestrel (rarely), the raven, the carrion crow, the hooded crow, the magpie.

4. *Egg-destroyers, which are tempted by the egg of any bird.*—The raven, the carrion crow, hooded crow, the jackdaw, the magpie, the jay.

5. *Birds which are apt to perch on any elevated post or stone, where a trap may be set unbaited.*—The buzzard, the harriers, the sparrow-hawk, the kestrel, the jackdaw, the jay, and, though more rarely, the peregrine falcon, hobby, and merlin.

Guided by these known habits, the keeper proceeds to lay his plans for circumventing the several species which infest his beat; but he will have great trouble with most of them, and especially with the various hawks, which can scarcely be trapped at all excepting in the breeding season, when their nests must be sought for, and as soon as the young are nearly fledged they must be taken alive; then selecting an open space, tolerably near the place of their nativity, fence it in, where necessary, with thorns, so as to exclude cats, stoats, &c., which may be taken with less valuable baits, and there set half-a-dozen steel traps, properly concealed, round a circle in which one of the poor little victims is securely fastened by the leg to a strong peg by a leather strap six inches long. If there are several of these young ones, two may be thus surrounded, one for each parent bird, and at some little distance from each other, reserving the remainder for a

milder fate, for if any accident should happen to the two first immolated, before the capture of the old birds, then those saved must take their turns in beguiling their parents to destruction. The old ones are sure, when they hear the cry of their young, to go down to their aid, and in walking round, endeavouring to accomplish their release, they spring one of the traps, and are irretrievably caught. This will succeed to a certainty with all the winged vermin, and no keeper who knows his business will suffer the eggs to be taken, because in that case he loses his chance of getting rid of the whole family at one swoop.

The birds which are ranged under the first list can sometimes be tempted by a live bait into an enclosure, made in as natural a manner as possible, upon the principle last described, setting the traps round in a similar manner. A tame pigeon tied by the leg, and suffered to walk round a limited circle, will attract the buzzard, the harriers, and sometimes the sparrow-hawk, and by these means they may be taken with one of a lot of traps, which must be thickly set outside the bait. The raven and the crow are quite as fond of dead flesh as living, and they may be caught with gins planted just at the edge of a piece of flesh, or a dead lamb, and securely fastened to a strong peg. An egg forms the best bait for the hooded crow or the magpie, and it will generally secure the attendance of either if fixed in a three-branched stick, eight or nine inches from the ground, and surrounded *closely* by steel traps. The jackdaw and the jay may be taken in the same way.

A good plan of trapping egg-destroyers is to set the trap in water, so that it will drown them when caught, and thus prevent them from alarming their own species and from escaping with the loss of a leg. To do this, proceed as follows:—Take a hen's egg, blow it, and fill it with clay or plaster of Paris, if it is to be had; insert a piece of wood in its side, sufficiently long to support it on a level with the water's surface when stuck in the bottom at the distance of the length of the trap from the water's edge; make a bridge of clay between the egg and the land, and on this set the trap, and conceal it with moss. The raven, crow, &c., will walk along this till they reach the egg, and inevitably spring

the trap in doing so. Of course the egg must be placed a few inches from the plate, greater or less, according to the size of the bird for which it is intended. The water beyond the egg should be deep, and if the trap is fastened by a long chain the birds will flutter into it, and soon sink out of sight.

Lastly, the unbaited steel-trap may be set on a pole or high stone, on the plan shown in fig. 97, at page 431. The spot may be selected without any other reason than its being the usual perch of some particular bird, if it is possible to find it out; but, supposing this is not known, then its habits must be considered, and advantage taken of them. A tame owl exposed in the daylight will serve to draw to the nearest perch most of the birds of prey, and especially the hawks, which it is otherwise very difficult to capture. If one is to be obtained it may, therefore, be tried, tying it on to a perch near a high post in a tolerably retired spot, but in the full glare of day. Here it is soon found out by a swarm of small birds, but unfortunately for the present purpose they will generally strike the gin and catch themselves instead of leaving it for the birds more desired by the keeper. Sometimes a dead cat, or any conspicuous dead animal, will draw from his retreat the hawk or the harrier, and then a gin on the nearest post is likely to capture either; but these expedients are rarely successful, and excepting in the breeding season the gun is far more serviceable than a whole score of these engines.

THE VERMIN TERRIER.

The vermin dog is the keeper's right hand, and even more than that, for without his aid he will lose one-half the captures of four-footed vermin, which he might otherwise make. No keeper should be without one carefully broken from game, and if he has a good dog, and knows how to use him, he need fear no loss of game by any vermin without feathers. Any kind of terrier with a cross of the bulldog *may* make a good vermin killer, but the special propensity to kill vermin rather than game runs in particular strains, which ought to be selected for the purpose.

POISON AND THE MODE OF LAYING IT.

A good trapper will seldom use poison, on account of the danger inseparably connected with it, either to the human kind or to dogs, whose lives are sometimes still more highly valued by keepers than the members of their own family. Sometimes, however, a particular bird or pair of birds is doing great damage, and yet is so cunning as to elude every trap set for him or them, and also to keep out of shot. Here strychnine may be justifiable, but only as a last resource, and its careless or indiscriminate use ought to cause the dismissal of the person employing it in that way. Of course strychnine cannot be employed against those birds which will not take a dead bait, and its effects are confined to those which will do so, and to the egg-destroyers, which may equally be taken by the steel-trap set round these baits as by the poison contained in them. I cannot, therefore, see the advantage of the process, but I have been assured by one or two really good keepers that they have been sometimes enabled to succeed with the one after failing with the other, and I therefore shall not set up my opinion against their more extended practice.

No other poison is to be compared with strychnine, five grains of which will suffice for any bait. This quantity may be inserted in its dry state, a pinch at a time, in punctures cut in the flesh which forms the bait, whether part of a larger animal or the whole of a small one. This should then be placed where dogs, cats, and children cannot get to it—that is, either beneath the earth in a run or in a tree. If an egg is used, a small hole is made in one end, the strychnine is inserted, a piece of the skin of another egg is glued over the opening with some of the white, and the aperture is securely sealed. The egg is then placed where it will be likely to be taken by the bird and is yet *out of the reach of children*, and there it is left till it is broken and despatched. The carcasses of all animals killed by this poison should be immediately buried.

CHAPTER IV.

POACHERS, AND THE BEST MODES OF COUNTERACTING
THEIR SCHEMES.

GENERAL REMARKS—LABOURERS THE BEST PRESERVERS OF GAME, AS
THEY ARE ALSO THE WORST POACHERS—THE CERTIFICATED POACHER
—THE REGULAR POACHER, AND HIS PROCEEDINGS.

Notwithstanding all the clever trapping and careful rearing which may be practised, and although a good head of game may be shown in July and August, yet, unless proper precautions are taken, it will be poached either before the season or as soon as it commences. The recently formed "Association for the Prevention of the Sale of Game out of Season" may be expected to do much in stopping poaching before the proper time for killing each kind of game, and it will doubtless put an end to the traffic in live birds, which has so long held out a premium to the wholesale poacher. There can be no excuse for the sale of live birds of game out of season any more than for that of dead game, for if pheasants are wanted to breed from they may, and ought to be obtained before the 12th of February, up to which time it is legal for licensed dealers in game to sell them—that is, up to ten days after the closing of the shooting season. Those who require more young birds than they breed to turn out for the approaching season may just as well wait till the 1st of October, for there are no tame-bred birds shot till the leaves are off the trees, and this seldom happens till the beginning of November. October pheasant shooting is confined to outlying birds bred in the small coverts and hedgerows near the great preserves, and does not include the *battues*, for which alone tame-bred birds are required. Hence, not even the most inveterate lover of wholesale murder is injured by a strict adherence to the letter of the law, while if he is a breeder he is benefited, because he cannot be tempted to buy his own young pheasants to turn down, as has more than once happened within my know-

ledge. If the market for game out of season, and especially for live game, is destroyed, one of the main supports of the wholesale poacher is done away with, for as long as he can get 15s. a brace for live birds he will take them in preference to 4s. 6d. to 5s. for dead ones, which are the respective prices paid to the poachers for pheasants.

LABOURERS THE BEST PRESERVERS OF GAME.

My own opinion has long ago been strongly expressed in favour of encouraging labourers to preserve the game from the poachers. They are of little use in trapping vermin, and wherever a good head of game is required a keeper must be maintained for that purpose and for generally superintending the game, especially where pheasants are to be reared; but for merely protecting partridges and grouse from poachers, commend me to the labourers on the south country farms and to the shepherds in the hill districts. If they are with you all the poachers in the world may be defied, while if they are against you no keeper can be sure of showing you good sport. The following observations on this subject were written five years ago in "British Rural Sports," when my knowledge of preserving was confined to a small district; but the more I have since seen and known of it throughout England and Scotland the more I am convinced of their truth:—

"With regard to the poacher, everything depends upon the labourers on the farms. If they like to countenance the poacher, or if they unfortunately are poachers themselves, all the efforts of a keeper will be of little avail. The best plan is to make all the labourers feel an interest in the preservation of the game. Let every man receive at Christmas a certain sum proportionate to the head of game killed during the season, and the outlay will be found to be well bestowed, since it will go much further than the same sum laid out in extra watchers. I have known 650 acres of land preserved entirely, in the neighbourhood of a large town, without any regular keeper, and with an outlay in the shape of presents to labourers certainly not exceeding 20*l.* a year. On this farm hares were as thick as sheep, and partridges sufficient

to allow thirty brace to be killed in three or four hours. All parties were in earnest in keeping poachers away, and the result was as I have stated. This shows what labourers can do if they like, and what they will do if it is made their interest to do so. They are either a great evil or a great boon to the game preserver, and he must make up his mind either to have them as warm friends or bitter enemies. The regular and systematic poacher is a formidable fellow, opposed to all law, and making a living in the best way he can. After a time nothing comes amiss to him; and, though at first he has taken to his trade from a love of sport, it has ended in his adhering to it from necessity, since he cannot get work when his character is known, nor can any man, after poaching all night, be fit for work in the day also."

The poaching labourer is the worst of all poachers, because his attacks on the game are insidious and constant. He does not, it is true, sweep a whole district in a night, but he steals the eggs in the breeding season, and when the shooting season begins he takes a covey quietly now and then, and his hare once or twice a week. These are not so much missed, and the loss therefore does not cause such an uproar as that caused by an incursion of poachers from a distance. To him bushing is no obstacle, because he watches the birds settle, marks to a yard where they are, and then takes them even if they are close to a bush. For these reasons, therefore, let the poaching labourer be stopped early in his career, before he becomes confirmed in his habits, and this may often be done by making it his interest to abstain. A few shillings and a civil word or two from master or man will often save the labourer, who is hesitating on the brink of the pit which leads to his own destruction, for there are few instances of the confirmed poacher ending his days in a respectable manner.

THE CERTIFICATED POACHER.

The certificated poacher is a great nuisance in some districts, numbers of such gentry making a living by selling their game, obtained on land over which they have no right to shoot. These men can only be fined 2*l.* and costs, if they are convicted; and, keeping out of the way of the watchers,

by giving leg bail they escape in the greater proportion of cases; while a single fair day's shooting will pay the penalty, when incurred. Such men are often good sportsmen, and their dogs first-rate, whereby they sometimes succeed in overcoming the animosity of the keepers or their masters. Of this I remember a notable example some years ago. A strict preserver of game, who was also very fond of a good dog, happened to come upon one of this class of poachers, in pursuit of a wounded pheasant, which his dog was in the act of retrieving. So intent was he on assisting his canine friend, that he overlooked the presence of the proprietor of the soil, till he was pulled up with "Hollo, sir! what are you about?" Nothing daunted, he exclaimed, "Stop a minute, squire, let my dog find this pheasant, and I will talk to you about it." "D—n your pheasant, at least, *my* pheasant, I should say; let it be, and I'll send you a summons to-morrow," was the angry response, which was met by what would only have irritated most men still more. "I won't have my dog spoiled for anybody; let him do his work, and I'm your man. Look, squire, can your retriever do that?" During this colloquy the dog had been proceeding in his work, and had led the two several hundred yards in various directions, the pheasant having been a runner, and taken to a dry ditch. At length he pegged his bird, and elicited so much admiration, that "The Squire" bought him for a long price, and not only forgave the offence, but promised an annual day's shooting, if his land was spared during the remainder of the season. The compact was made, and fairly kept, to the great advantage of the owner of the soil, who thereby benefited considerably, for the levier of the "black mail" kept other poachers off for his own sake, as well as out of consideration for the squire's knowledge of dogs, and admiration of his own powers of breaking.

THE REGULAR POACHER AND HIS PROCEEDINGS.

The systematic poacher is of all ages and classes. Some are brought up in luxury, but refusing to work, they descend in the scale, and consider poaching the only gentlemanly way of earning money. Others have been reared as labourers,

but, beginning with a single hare or partridge, they have incurred the displeasure of their master, have been thrown out of work, and almost compelled to carry on their unlawful vocation. From all these the keepers and watchers have to protect the game, and this at all hours and seasons. Every year they assume some new mode of attack, and countermine as fast as the keeper forms his schemes for detecting them.

There are several precautions which every keeper regularly takes, varying according to the locality where his beat is fixed. Everywhere, however, he, as well as all his watchers, must obtain a knowledge of the persons of all the poachers in his district, and this alone will greatly serve to keep them quiet. Poachers will never go, by choice, where they know they are sure to be recognised; while, on the other hand, wherever there is a keeper who relies upon his brute strength, the poacher goes at once, preferring a good thrashing, or the chance of a shot, to the certainty of identification, which spoils all his after prospects. The moment he goes into court all the keepers in the neighbourhood put their mark upon him, and he must work an uphill game in all directions. There are certain nights when the keeper's experience tells him that particular kinds of poaching will be practised, and on these he will take especial care to watch the poacher and all his gang, by the aid of his assistants. In some counties this is comparatively easy, but in wooded districts it is almost impossible, if the poacher's cottage is surrounded by trees; but as far as may be the plan should be carried out, and instead of allowing the poacher to watch him, the keeper should be the most on the alert. In open countries, a telescope serves the cause, and one man on a commanding spot can blockade two or three cottages till the evening sets in, when, to make sure, one watcher must be set on each doubtful offender. In this way it is very difficult to elude detection, and as in very dark, as well as very light, nights nothing will be likely to be attempted, there is nearly half the month in which watching is very little required. In pitch dark nights nothing can be done for want of light, while in strong moonlight identification is almost as easy as in bright daylight—and the poacher, unless he is greatly pressed for money, will seldom risk it. A dim light, which will just

enable him to see a pheasant as a dark body in the trees, is the one selected; and if there is a strong wind to drown the sound of the gun, so much the better. Hence it is that the mock-pheasant is so useful in deceiving these men; for if it is examined at the full moon, it will never be mistaken for the real bird. Nothing annoys the poacher more, for he hates to shoot without any result; and, if these decoys are well made, no eye can tell the real from the counterfeit. The following is a cheap and good plan of making them. They are very easily moved from branch to branch, a nail being merely driven into a probable perch, and standing upright, it is received into the hole drilled in the body, which is thus secured from falling, while it sways gently backwards and forwards, exactly like the living bird. Fig. 100 represents *a* the perfect bird, of which *b* is a section; *c* shows the pole from which the bodies are cut, and *d* the lath forming the tail, fastened on with two nails.

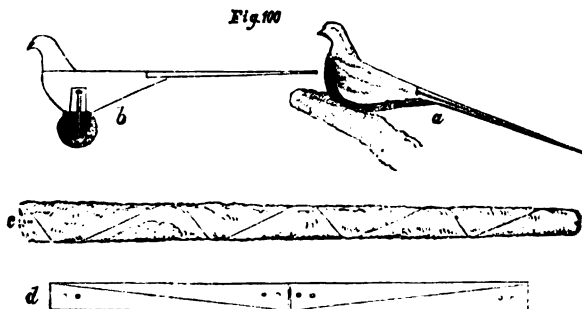

THE MOCK PHEASANT.

For partridges bushing is the best remedy that can be adopted against the nets, which are yearly swept over the ground wherever the poacher thinks he can do so with impunity. The bushes are often stuck in the ground at regular intervals and in straight rows, but this should never be done as the poachers sweep the nets up between the lines and thus set the bushing at defiance. They should be stuck into the

ground at about twenty yards distance from each other, but as irregularly as possible. Wheat stubbles and upland grass are the most probable roosting places of these birds, but barley stubbles without seeds are nearly as likely, and even the seeds themselves are sometimes chosen. Few labourers sleep through the night without being aware of the use of the net, which cannot be drawn without some noise, and if they like they can always give the keeper warning and stop the netting at once.

Hares are taken by gate nets, after stopping all the meuses in the field, when a mute dog soon drives all within it into the net. Or they are snared in the fatal wire, or caught in small bag nets placed over some of the meuses, the others being stopped. The nets are the most fatal methods because they are soon put down and soon taken up again, whereas the wires require some little time to set. Long nets are sometimes set in the open, and the hares driven into them, and wires are also set on their runs, where they are caught even more easily than in the meuse. Hares and rabbits always stop and examine the meuse unless closely pressed, but they run carelessly along in the open, and put their necks within the snare without the slightest hesitation. An artist in his line will scarcely miss a hare if he is left undisturbed, and allowed to inspect the ground freely beforehand. So also in coverts, they are completely cleared by the clever poacher in a very short time, if he is permitted to get into them and set his wires. Long netting both for hares and partridges is the most difficult to circumvent, excepting by watching the poachers themselves and so taking care that they cannot meet together in any number without its being known. Scarcely any known method will stop it, for the nets may be fixed anywhere, and as the game is driven into them no bushing or similar set of obstacles is of any use.

The Scotch poachers in the Highland districts are very difficult to counteract, because they have such a wide scope, and can seldom be caught unawares. Even in the daytime they manage to get to leeward of the keepers and watchers, and thus are able to proceed in their task, shooting away till they have killed as much as they can carry. Grouse are netted in large numbers before the season and kept till they can be

sold, which I trust in future will not be till after the 11th. of August. Here a first-rate keeper is required, aided by a clever set of watchers, and they will have their hands full just before the season, and towards the latter part of it, when the shooters are not so thick on the ground.

From the many difficulties which I have shown to exist in counteracting the poacher when he has once set to work, I must impress upon my readers the importance of taking every precaution to keep him blockaded at home. This requires a considerable number of watchers who are to be depended on, but after all it is the only effectual way, and as such is the cheapest in the end. The grand secret in game preserving is to depend upon the prevention of mischief in its commencement, and not upon stopping it when it has gained its full swing. Many a man would stay at home if he knew that he was going to risk a murder, but if his blood is up, his pride and his obstinacy, or courage if you like to call it so, alike prevent him from allowing himself to be foiled.

CHAPTER V.

THE GAME LAWS.

GENERAL REMARKS—ENGLISH GAME LAW OF 1831—LAW FOR PERMITTING THE KILLING OF HARES IN ENGLAND—SCOTCH LAWS, INCLUDING THAT PERMITTING THE KILLING OF HARES, AND ALSO THE LAW OF TRESPASS—IRISH GAME LAWS—NEW GAME LICENCE ACT.

THE limited space which can be given to this subject in the present work prevents me from entering into the history of these laws, and I must confine my attention to the working of those parts of them which more especially concern the shooter. It is most unfortunate that the laws relating to game differ most essentially in England, Ireland, and Scotland—so that a sportsman who is only acquainted with the law of one of these countries, is constantly liable to break that which prevails in either of the others. This still

further restricts my remarks, as it will be necessary to show the sportsmen of the three countries the position in which they stand.

THE ENGLISH GAME LAWS.

To the general reader, for whom alone these remarks are intended, it may be necessary to premise, that offences of all kinds are punishable by the common law, which is dependent upon the practice of the courts, and is unwritten; and also by statute laws, which from time to time have been made by the Acts of our Parliament. In the case of game there are several of the latter kind now in existence, as the Game Law of 1831; the law permitting the killing of hares; the law regulating certificates, &c., &c. Now, if it happens that the punishment for an offence is clearly provided for by the statute law, there is no difficulty, and comparatively little expense; but if, on the contrary, the common law must be had recourse to, an action must be brought in the ordinary courts, and a heavy outlay is required. Sometimes the proof of an act having been committed required by the two laws is quite different—as in the case of trespass, which, by the common law, is committed by a person who remains upon a road, but sends his dog into the fields to beat to him. This offence, however, does not come under the definition of the 3rd and 4th William IV., c. 32, which demands an actual “being upon the soil” of the person of the trespasser. The mere damage done in the trespass is also generally so trifling, and the proceedings at common law are so expensive, that few people like to have recourse to it; and in my opinion, if an offence is not clearly made out by one of the statutes made to apply to such cases, it is better under ordinary circumstances to put up with the consequences.

The experience of the last twenty-five years tells us that the present law is by no means as satisfactory as it might be made; but while there is so strong a feeling against any game law, as there is now in a large section of the people, it is dangerous to make the attempt to alter it. If, however, the task should be forced upon the Legislature; or if, at any future time, the Government should feel strong enough to carry a new bill, the following suggestions, made by Colonel

Layard (the chief of the constabulary in the East Riding of Yorkshire), to the Hon. Grantley Berkeley, are deserving of great attention—not only as coming from an official who has long been concerned in putting down crimes of all kinds in a county where game preserving is strictly carried out, but as being of a most feasible character in themselves.

The following are Colonel Layard's suggestions:—"With reference to the best mode of putting down the present system of poaching, which has of late been carried to such a fearful extent that life and property are unhesitatingly sacrificed to effect their purpose by those who live by it and acknowledge no other trade or mode of gaining a livelihood, I would suggest that a clause be introduced into the Vagrant Act empowering a magistrate 'to commit to the house of correction for any period not exceeding one month, or less than fourteen days, all persons apprehended with game in their possession between the proscribed hours of night—viz., one hour after sunset and one hour after sunrise, if such persons cannot satisfactorily account for having game in their possession, showing whence it came, and to whom it belongs.' Further, I would recommend that all game found on such parties as are committed, 'be sold by order of the magistrate to some licensed dealer in game, the proceeds to be applied, in the first instance, to defray all expenses incurred in the apprehension of the offender; and should there be any surplus, the same to be paid over to the county rate.' Thus, the constabulary of any county or borough, acting (as they have power to do) upon the right to search all suspicious characters entering towns or met on the roads during the night, would have the power to detain all such parties, and bring them before a justice; and by the frequent and constant recurrence of apprehension, and their loss of the game, poaching would cease to be a lucrative trade or occupation, as it now is.

"As the law now stands, the police are daily searching parties on whom game is found in great quantities; and the notorious poacher will boast to them of having had a good night of it, or not, as the case may be; but if one head of poultry was found on them, they could at once be detained.

"As regards the sale of game by unlicensed persons, it

has been suggested that all game found on suspicious parties, whether in carts, or boats, or other vehicles, should be liable to be seized by the police, and taken before a magistrate, 'who shall have power to direct it to be forfeited and sold as before stated—if the person claiming it cannot prove an undoubted right to it by a legitimate purchase as a licensed dealer, or as having killed it on his own grounds.' It would also be worth consideration how far it would be advisable to increase the price of a licence for dealing in game, from the present lower figure of 2*l.* to one of 10*l.*, thus insuring a more respectable class of tradesmen."

**THE NEW GAME LAW OF 1831 FOR ENGLAND AND WALES
(1 & 2 WILL. 4, CAP. XXXII.).**

I. Repeals the following Acts—viz, 13 Ric. 2, st. 1, c. 13; 22 Edw. 4, c. 6; 11 Hen. 7, c. 17; 19 Hen. 7, c. 10; 14 & 15 Hen. 8, c. 16; 25 Hen. 8, c. 11; 33 Hen. 8, c. 6; 23 Eliz. c. 10; 2 Jac. 1, c. 27; 7 Jac. 1, c. 11; 22 & 23 Car. 2, c. 25; 4 W. & M. c. 23; 5 Ann. c. 14; 9 Ann. c. 25; 8 G. 1, c. 19; 10 G. 2, c. 32; 26 G. 2, c. 2; 28 G. 2, c. 12; 2 G. 3, c. 19; 13 G. 3, c. 55; 13 G. 3, c. 80; 39 G. 3, c. 34; 43 G. 3, c. 112; 50 G. 3, c. 67; 58 G. 3, c. 75; 59 G. 3, c. 102.

II. *What shall be deemed game.*—And be it enacted, that the word "Game" shall for all the purposes of this Act be deemed to include hares, pheasants, partridges, grouse, heath or moor game, black game, and bustards; and that the words "Lord of a Manor, Lordship, or Royalty, or reputed Manor, Lordship, or Royalty," shall throughout this act be deemed to include a lady of the same respectively.

III. *Days and seasons during which game shall not be killed.—Penalty for laying poison to kill game.*—And be it enacted, that if any person whatsoever shall kill or take any game, or use any dog, gun, net, or other engine or instrument for the purpose of killing or taking any game, on a Sunday or Christmas Day, such person shall on conviction thereof before two justices of the peace, forfeit and pay for every such offence such sum of money, not exceeding five pounds, as to the said justices shall seem meet, together with the costs of the conviction; and if any person whatsoever shall kill or take any partridge between the first day of February and the first day of September in any year, or any pheasant between the first day of February and the first day of October in any year, or any black game (except in the county of Somerset or Devon, or in the New Forest in the county of Southampton) between the tenth day of December in any year and the twentieth day of August in the succeeding year, or in the county of Somerset or Devon, or in the New Forest aforesaid, between the tenth day of December in any year and the first day of September in the succeeding year, or any grouse commonly called red game between the tenth day of December in any year and the twelfth day of

August in the succeeding year, or any bustard between the first day of March and the first day of September in any year, every such person shall, on conviction of any such offence before two justices of the peace, forfeit and pay, for every head of game so killed or taken, such sum of money, not exceeding one pound, as to the said justices shall seem meet, together with the costs of the conviction; and if any person, with intent to destroy or injure any game, shall at any time put or cause to be put any poison or poisonous ingredient on any ground, whether open or inclosed, where game usually resort, or in any highway, every such person shall, on conviction thereof before two justices of the peace, forfeit and pay such sum of money, not exceeding ten pounds, as to the said justices shall seem meet, together with the costs of the conviction.

IV. *Possession of game illegal after ten days in dealers, and forty days in other persons, from the expiration of the season.*—And be it enacted, That if any person licensed to deal in game by virtue of this act as hereinafter mentioned shall buy or sell, or knowingly have in his house, shop, stall, possession, or control, any bird or game after the expiration of ten days (one inclusive and the other exclusive) from the respective days in each year on which it shall become unlawful to kill or take such birds of game respectively as aforesaid; or if any person, not being licensed to deal in game by virtue of this act, as hereinafter mentioned, shall buy or sell any bird of game after the expiration of ten days (one inclusive and the other exclusive) from the respective days in each year on which it shall become unlawful to kill or take such birds of game respectively as aforesaid, or shall knowingly have in his house, possession, or control, any bird of game (except birds of game kept in a mew or breeding place, after the expiration of forty days, one inclusive and the other exclusive) from the respective days in each year on which it shall become unlawful to kill or take such birds of game respectively as aforesaid; every such person shall, on conviction of any such offence before two justices of the peace, forfeit and pay for every head of game so bought or sold, or found in his house, shop, possession, or control, such sum of money, not exceeding one pound, as to the convicting justices shall seem meet, together with the costs of the conviction.*

* One of the most important results of the formation of the new Association for the Prevention of the Sale of Game out of Season is the acknowledgment of the stringent nature of the law, which forbids the sale of live as well as dead birds of game out of the proper season. Hitherto it has been generally held, though we find it to be otherwise laid down in the law books, that a dealer in live game might lawfully sell birds of game if *tame bred* at any season of the year; and upon this interpretation of the act advertisements for the sale of live pheasants have been admitted into the columns of the sporting papers, for, though their conductors have always believed that nine-tenths of the pheasants thus sold were poached, they considered that they had no right to act upon this hypothesis, and therefore, though reluctantly, the advertisements were allowed to appear. But on the formation of the new Association a case was tried before the Lord Mayor, the law was examined care-

V. *This act not to affect the existing laws respecting game certificates.*—And be it enacted, that nothing in this act contained shall in any wise affect or alter (except as hereinafter mentioned) any act or acts now in force by which any person using any dog, gun, net, or other engine for the purpose of taking or killing any game whatever, or any woodcock,

fully, and it was discovered that at no period between the 10th of February and the 1st of October can live pheasants, nor between the former date and the 1st of September can live partridges *be sold, unless the contract for their delivery had previously been made*, this exception having been ruled to be good in the case of *Porritt v. Baker* and another (10 Ex. R. 759).

From this it clearly appears that the buying or selling is forbidden under any circumstances during the close time; but in the case cited above it was held that if the agreement to sell is made during the season, the delivery may be effected afterwards; and fortunately in this case there can be no probable evasion of the law, because one party to the transaction is almost always a proprietor of game, whose evidence may fairly be accepted as trustworthy. But the succeeding clause of the section appears to throw some difficulty in the way of the unseasonable delivery of these birds so bargained for, since we find that the penalty is enforced upon any person "who shall knowingly have in his house, possession, or control, any bird of game (*except birds of game kept in a mew or breeding-place*)", and therefore the seller is liable from the moment that they leave one "mew or breeding-place" to that in which they enter another, or are turned out. It cannot be argued, and no attempt was made to that effect before the Lord Mayor, that a hamper in a market-place is a "mew or breeding-place," and hence we believe that the sale of live birds of game is practically forbidden by the Act out of the season during which the corresponding birds can be legally sold when dead.

Such is the law of the case; but it may be said that it is an unsatisfactory law, and so it is alleged to be by the dealers who live upon its profits, but by no good sportsman as far as I know. The facts really are, that thousands, and probably tens of thousands of poached pheasants are annually sold by such men. A profit of from 5*s.* to 10*s.* a brace is made on them; and this in "large contracts" is a pretty heavy fine for game preservers to pay. Lazy keepers persuade their masters that the trade is necessary, and sometimes connive at the sale to them of their own birds previously stolen for the purpose. Such practices must be put down, and the Association will deserve the thanks of the shooting community if they will earnestly carry through their purpose so auspiciously commenced in the present year. There is plenty of time before the 10th of February for the sale of old birds intended for turning out or laying, and after the 30th of September for that of young ones which are to stock the preserves for the current year. The breeder may lawfully keep these in their proper breeding-places till then, and as few preservers shoot any but their small outlying coverts (where tame-bred birds are never put down) till the end of October, and most not until November, there is plenty of time in the interval for the purpose. Even if some slight inconvenience is thereby

snipe, quail, or landrail, or any conies, are required to obtain and have annual game certificates, but that all persons who before the commencement of this act were required to obtain and have such certificates, shall after the commencement of this act be required from time to time to obtain and have the like certificates; and all the powers, provisions, and penalties contained in such act or acts shall continue in as full force and effect as if this act had not been made; and that all regulations and provisions contained in any act or acts relative to game certificates, so far as they relate to gamekeepers of manors, and to the amount of duty for game certificates to be charged upon or in respect of gamekeepers of manors in the cases specified in such act or acts, shall extend and apply to all gamekeepers of lands appointed under this act as fully and effectually as if they were gamekeepers of manors, and were expressly mentioned and charged by such act or acts.*

VI. *Every certificated person may kill game, subject to the law of trespass.—Proviso as to gamekeepers.*—And be it declared and enacted, that every person who shall have obtained an annual game certificate shall be authorized to kill and take game, subject always to an action, or to such other proceedings as are hereinafter mentioned, for any trespass by him committed in search or pursuit of game: provided always, that no game certificate on which a less duty than three pounds thirteen shillings and sixpence is chargeable under the acts relating to game certificates shall authorize any gamekeeper to kill or take any game, or to use

caused, it is far better to put up with this than to sanction the wholesale poaching which has long been carried on.

The sellers of live game are loud in their denunciation of the sale of dead game out of season, and this practice, we believe, is not defended by any but the Manchester school. In that city game is sold nearly all the year round, and probably there are many dealers there in the dead article who would retort upon our specious correspondent. There is, however, far more difficulty in detecting these gentry, for a dead grouse or a pheasant may be stowed away in small compass out of sight, whereas a living one requires air and room. "Scotch pigeons" are only sold to those who are known to be trustworthy law-breakers, and though the Association have succeeded in obtaining evidence of the sale of black game in several instances, we believe it was chiefly because of the leniency shown to Castang, the defendant in the first case, in not pressing for the full penalty. The Society, however, did not wish to do more in his instance than assert the law; but hereafter, I believe, it is their intention to press in every case for the highest penalty which the magistrates will inflict. Black game are no more fit to be shot before the 20th of August than pheasants are prior to the 1st of October, or partridges in the month of August; and though occasional mistakes may be made, they cannot possibly account for the enormous numbers that have been annually sold in Leadenhall, Newgate, and Hungerford markets, before the commencement of the proper season. (Article in *The Field*, 1859.)

* The price of a certificate, and all matters connected with it, will be found in the New Licence Act, at the end of this volume.

any dog, gun, net, or other engine or instrument for the purpose of killing or taking game, except within the limits included in his appointment as gamekeeper; but that in any case where such gamekeeper shall kill or take any game, or use any dog, gun, net, or other engine or instrument for the purpose of killing or taking game, beyond such limits as aforesaid, he may be proceeded against under this act, or otherwise, in the same manner to all intents and purposes as if he had no game certificate whatsoever.

VII. *Under existing leases the landlord shall have the game, except in certain cases.*—And be it enacted, that in all cases where any person shall occupy any land under any lease or agreement made previously to the passing of this act, except in the cases hereinafter next excepted, the lessor or landlord shall have the right of entering upon such land, or of authorizing any other person or persons who shall have obtained an annual game certificate to enter upon such land, for the purpose of killing or taking the game thereon; and no person occupying any land under any lease or agreement, either for life or for years, made previously to the passing of this act, shall have the right to kill or take the game on such land, except where the right of killing the game upon such land has been expressly granted or allowed to such person by such lease or agreement, or except where upon the original granting or renewal of such lease or agreement a fine or fines shall have been taken, or except where in the case of a term for years such lease or agreement shall have been made for a term exceeding twenty-one years.

VIII. *This act not to affect any existing or future agreements respecting game, nor any rights of manor, forest, chase, or warren.*—Provided always, and be it enacted, that nothing in this act contained shall authorize any person seised or possessed of or holding any land to kill or take the game, or to permit any other person to kill or take the game upon such land, in any case where, by any deed, grant, or lease, or any written or parol demise or contract, a right of entry upon such land for the purpose of killing or taking the game hath been or hereafter shall be reserved or retained by or given or allowed to any grantor, lessor, landlord, or other person whatsoever; nor shall anything in this act contained defeat or diminish any reservation, exception, covenant, or agreement already contained in any private act of Parliament, deed, or other writing relating to the game upon any land, nor in any manner prejudice the rights of any lord or owner of any forest, chase, or warren, or of any lord of any manor, lordship, or royalty, or reputed manor, lordship, or royalty, or of any steward of the Crown of any manor, lordship or royalty appertaining to his Majesty.

IX. *This act not to affect any of his Majesty's forest rights, &c.*—Provided also, and be it enacted, that nothing in this act contained shall in any way alter or affect the prerogative, rights, or privileges of his Majesty, his heirs or successors, nor the powers or authorities now vested in the Commissioners of his Majesty's Woods, Forests, and Land Revenues, in or relating to any of his Majesty's forests or the boundaries thereof, nor in or relating to the appointment of any stewards, gamekeepers, or other officers of any of his Majesty's forests, parks, or chases, or of any hundred, honor, manor, or lordship, being part of the possessions and land revenues

of the Crown, nor the rights, privileges, or immunities of any chief justice in eyre, or any warden, deputy-warden, or lieutenant of any of his Majesty's forests, or any rangers, verderers, foresters, master-keepers, under-keepers, or other officers of or in any such forests, parks, or chases, or of any person entitled to any right or privilege under them or any of them, nor the rights or privileges of any persons holding under any grants or purchases from the Crown, nor give to any lord of any manor or manors within any forest or the boundaries thereof, nor to any other person whatsoever, any privileges, rights, or powers within any such forest, park, or chase, or the boundaries thereof, which he did not possess or to which he was not entitled before the passing of this act, but that all the aforesaid prerogatives, immunities, privileges, rights and powers shall remain as if this act had not been made.

X. *Not to affect any cattlegates or right of common*.—Lord of manor to have the game on the wastes.—Provided also, and be it enacted, that nothing herein contained shall be deemed to give to any owner of cattlegates or rights of common upon or over any wastes or commons any interest or privilege which such owner was not possessed of before the passing of this act, nor to authorize such owner of cattlegates or rights of common to pursue or kill the game found on such wastes or commons; and that nothing herein contained shall defeat or diminish the rights or privileges which any lord of any manor, lordship, or royalty, or reputed manor, lordship, or royalty, or any steward of the Crown of any manor, lordship, or royalty, appertaining to his Majesty, may, before the passing of this act, have exercised in or over such wastes or commons; and that the lord or steward of the Crown of every manor, lordship, or royalty, or reputed manor, lordship, or royalty, shall have the right to pursue and kill the game upon the wastes or commons within such manor, lordship, or royalty, or reputed manor, lordship, or royalty, and to authorize any other person or persons who shall have obtained an annual game certificate to enter upon such wastes or commons for the purpose of pursuing and killing the game thereon.

XI. *Landlord having the game, may authorize others to kill it*.—And be it enacted, that where the lessor or landlord shall have reserved to himself the right of killing the game upon any land, it shall be lawful for him to authorize any other person or persons who shall have obtained an annual game certificate to enter upon such land for the purpose of pursuing and killing game thereon.

XII. *Where the landlord, &c., has the right to the game, in exclusion of the occupier, the occupier shall be liable to a penalty for killing it*.—And be it enacted, that where the right of killing the game upon any land is by this act given to any lessor or landlord, in exclusion of the right of the occupier of such land, or where such exclusive right hath been or shall be specially reserved by or granted to, or doth or shall belong to, the lessor or landlord, or any person whatsoever other than the occupier of such land, then and in every such case, if the occupier of such land shall pursue, kill, or take any game upon such land, or shall give permission to any other person so to do, without the authority of the lessor, landlord, or other person having the right of killing the game upon such land, such occupier shall, on conviction thereof before two justices of

the peace, forfeit and pay for such pursuit such sum of money not exceeding two pounds, and for every head of game so killed or taken such sum of money not exceeding one pound, as to the convicting justices shall seem meet, together with the costs of the conviction.

XIII. *Lords of manors may appoint gamekeepers*.—Powers of gamekeepers in manors.—And be it enacted, that it shall be lawful for any lord of a manor, lordship, or royalty, or reputed manor, lordship, or royalty, or any steward of the Crown of any manor, lordship, or royalty, appertaining to his Majesty, by writing under hand and seal, or in case of a body corporate, then under the seal of such body corporate, to appoint one or more person or persons as a gamekeeper or gamekeepers to preserve or kill the game within the limits of such manor, lordship, or royalty, or reputed manor, lordship, or royalty, for the use of such lord or steward thereof, and to authorize such gamekeeper or gamekeepers within the said limits to seize and take for the use of such lord or steward, all such dogs, nets, and other engines and instruments for the killing or taking of game as shall be used within the said limits by any person not authorized to kill game for want of a game certificate.

XIV. *Lords of manors may grant deputations*.—And be it enacted, that it shall be lawful for any lord of a manor, lordship, or royalty, or reputed manor, lordship, or royalty, or any steward of the Crown of any manor, lordship, or royalty, appertaining to his Majesty, to appoint and depute any person whatever, whether acting as a gamekeeper to any other person or not, or whether retained and paid for as the male servant of any other person or not, to be a gamekeeper for any such manor, lordship, or royalty, or reputed manor, lordship, or royalty, or for such division or district of such manor, lordship, or royalty, as such lord or steward of the Crown shall think fit, and to authorize such person, as gamekeeper, to kill game within the same for his own use or for the use of any other person or persons who may be specified in such appointment or deputation, and also to give to such person all such powers and authorities as may by virtue of this act be given to any gamekeeper of a manor; and no person so appointed gamekeeper, and empowered to kill game for his own use or for the use of any other person so specified as aforesaid, and not killing any game for the use of the lord or steward of the Crown of the manor, lordship, or royalty, or reputed manor, lordship, or royalty, for which such deputation or appointment shall be given, shall be deemed to be or shall be entered or paid for as the gamekeeper or male servant of the lord or steward making such appointment or deputation, anything in any act or acts contained to the contrary notwithstanding.*

XV. *Regulations respecting appointment of gamekeepers in Wales*.—And be it enacted, that it shall be lawful for every person who shall be entitled to kill the game upon any lands in Wales of the clear annual value of five hundred pounds, whereof he shall be seised in fee or as of freehold, or to which he shall otherwise be beneficially entitled in his own right, if such lands shall not be within the bounds of any manor, lordship, or royalty, or if, being within the same, they shall have been enfranchised

* Gamekeeper's certificates vary according to circumstances.—See New Licence Act.

or alienated therefrom, to appoint, by writing under his hand and seal, a gamekeeper or gamekeepers to preserve or kill the game over and upon such his lands, and also over and upon the lands in Wales of any other person, who, being entitled to kill the game upon such last-mentioned lands, shall by licence in writing authorize him to appoint a gamekeeper or gamekeepers to preserve or kill the game thereupon, such last-mentioned lands not being within the bounds of any manor, lordship, or royalty, or having been enfranchised or alienated therefrom; and it shall be lawful for the person so appointing a gamekeeper or gamekeepers to authorize him or them to seize and take, for the use of the person so appointing, upon the lands of which he or they shall be appointed gamekeeper or gamekeepers, all such dogs, nets, and other engines and instruments for the killing or taking of game as shall be used upon the said lands by any person not authorized to kill game for want of a game certificate.

XVI. *All appointments of gamekeepers to be registered with the clerk of the peace.*—Provided always, and be it enacted, that no appointment or deputation of any person as a gamekeeper by virtue of this act shall be valid unless and until it shall be registered with the clerk of the peace for the county, riding, division, liberty, franchise, city, or town wherein the manor, lordship, or royalty, or reputed manor, lordship, or royalty, or the lands, shall be situate, for or in respect of which such person shall have been appointed gamekeeper; and in case the appointment of any person as gamekeeper shall expire or be revoked, by dismissal or otherwise, all powers and authorities given to him by virtue of this act shall immediately cease and determine.

XVII. *Certificated persons may sell game to licensed dealers.*—*Proviso as to gamekeepers.*—And be it enacted, that every person who shall have obtained an annual game certificate shall have power to sell game to any person licensed to deal in game, according to the provisions hereinafter mentioned: provided always, that no game certificate on which a less duty than three pounds thirteen shillings and sixpence is chargeable under the acts relating to game certificates shall authorize any gamekeeper to sell any game, except on the account and with the written authority of the master whose gamekeeper he is; but that any such gamekeeper selling any game not on the account and with the written authority of such master may be proceeded against under this act in the same manner, to all intents and purposes, as if he had no game certificate whatsoever.

XVIII. *Justices to hold a special session yearly for granting licences to persons to deal in game.*—*Dealers in game to put up a board.*—And be it enacted, that the justices of the peace of every county, riding, division, liberty, franchise, city, or town shall hold a special session in the division or district for which they usually act. in the present year, between the fifteenth and the thirtieth days of October, and in every succeeding year in the month of July, for the purpose of granting licences to deal in game, of the holding of which session seven days' notice shall be given to each of the justices acting for such division or district, and the majority of the justices assembled at such session, or at some adjournment thereof, not being less than two, are hereby authorized (if they

shall think fit) to grant, under their hands, to any person being a householder or keeper of a shop or stall within such division or district, and not being an innkeeper or victualler, or licensed to sell beer by retail, nor being the owner, guard, or driver of any mail coach, or other vehicle employed in the conveyance of the mails of letters, or of any stage coach, stage waggon, van, or other public conveyance, nor being a carrier or higgler, nor being in the employment of any of the above-mentioned persons, a licence according to the form in the schedule (A) annexed to this act, empowering the person to whom such licence shall be so granted to buy game at any place from any person who may lawfully sell game by virtue of this act, and also to sell the same at one house, shop, or stall only, kept by him; provided that every person, while so licensed to deal in game as aforesaid, shall affix to some part of the outside of the front of his house, shop, or stall, and shall there keep, a board having thereon in clear and legible characters his Christian name and surname, together with the following words, (that is to say,) "Licensed to deal in game;" and every such licence granted in the present year shall begin to be in force on the first day of November in the present year, and shall continue in force until the fifteenth day of July, one thousand eight hundred and thirty-two, and every such licence granted in any succeeding year shall continue in force for the period of one year next after the granting thereof.

XIX. *Persons licensed to deal in game must take out a certificate, with a duty of 2l.*—And be it enacted, that every person who shall have obtained any licence to deal in game under the provisions of this act shall annually and during the continuance of his licence, and before he shall be empowered to deal in game under such licence, obtain a certificate according to the form in the schedule (B) annexed to this act, on payment of the duty of two pounds, which is hereby granted and made payable to his Majesty for every such certificate, which certificate shall be in force for the same period as such licence; and the said duty shall be paid to the collector or collectors of the assessed taxes for the parish, township, or place in which the person so licensed shall reside, in like manner as the duties on game certificates are by law payable; and every receipt to be given by any collector receiving such duty shall be free of stamp duty, and shall be delivered to the person requiring the same, on payment to the collector of one shilling, and no more, over and above the said duty for the certificate; and such receipt shall be exchanged for a certificate under this act, in like manner as receipts for the duty in respect of killing game are by law required to be exchanged for game certificates; and if any person obtaining a licence under this act shall purchase or sell or otherwise deal in game, as a licensed dealer under this act, before he shall obtain a certificate in exchange for a receipt as herein directed, such person shall for every such offence forfeit and pay the penalty of twenty pounds.

XX. *Collectors to make out list of persons who have obtained licences to deal in game.*—And be it enacted, that the collector or collectors of the assessed taxes in every parish, township, or place wherein any person shall reside who shall have obtained such annual licence and certificate, shall in each year make out a list, to be kept in his or their possession,

containing the name and place of abode of every such person, and shall at all reasonable hours produce such list to any person making verbal application to inspect the same, and shall be entitled to demand and receive for such inspection the sum of one shilling; and the duties hereby granted as aforesaid in respect of certificates to be obtained by persons licensed to deal in game shall be assessed, charged, raised, levied, and collected by the respective commissioners and justices of the peace, and the several other officers acting in the execution of the several acts relating to the assessed taxes, in the same manner, and under the same rules, regulations, and provisions, (except as herein varied,) as the duties on game certificates are by the said acts directed to be assessed, charged, raised, levied, and collected; and that the penalty of twenty pounds hereby imposed shall be sued for, recovered, and levied either in the district in which the offence shall be committed, or in the district in which the offender shall reside, and be applied in the same manner, and under the same rules, regulations, and provisions, as penalties on persons doing acts without payment of the game duty, or neglecting to obtain game certificates, are by the said acts directed to be sued for, recovered, levied, and applied, to all intents and purposes whatsoever as if such rules, regulations, and provisions were specially repeated and re-enacted in this act.

XXI. *Proviso as to partners.*—Provided always, and be it enacted, that persons being in partnership, and carrying on their business at one house, shop, or stall only, shall not be obliged by virtue of this act to take out more than one licence in any one year to authorize them to deal in game at such house, shop, or stall.

XXII. *Licences when to become void.*—And be it enacted, that if any person licensed by virtue of this act to deal in game shall during the period of such licence be convicted of any offence whatever against this act, such licence shall thereupon become null and void.*

XXIII. *Penalty for killing game without a certificate.*—*This penalty to be cumulative.*—And be it enacted, that if any person shall kill or take any game, or use any dog, gun, net, or other engine or instrument for the purpose of searching for or killing or taking game, such person not being authorized so to do for want of a game certificate, he shall, on conviction thereof before two justices of the peace, forfeit and pay for every such offence such sum of money not exceeding five pounds, as to the said justices shall seem meet, together with the costs of the conviction: provided always, that no person so convicted shall by reason thereof be exempted from any penalty or liability under any statute or statutes relating to game certificates, but that the penalty imposed by this act shall be deemed to be a cumulative penalty.

XXIV. *Penalty for destroying or taking the eggs of game, &c.*—And be it enacted, that if any person not having the right of killing the game

* This section is of the utmost importance, as it makes the loss of the licence to sell game imperative, after a conviction, for any deed committed against the provisions of this act, as, for instance, selling game out of season.

upon any land, nor having permission from the person having such right, shall wilfully take out of the nest or destroy in the nest upon such land the eggs of any bird of game, or of any swan, wild duck, teal, or widgeon, or shall knowingly have in his house, shop, possession, or control any such eggs so taken, every such person shall, on conviction thereof before two justices of the peace, forfeit and pay for every egg so taken or destroyed, or so found in his house, shop, possession, or control, such sum of money, not exceeding five shillings, as to the said justices shall seem meet, together with the costs of the conviction.

XXV. Penalty for selling game without licence, and on certificated persons selling to unlicensed persons.—And be it enacted, that if any person, not having obtained a game certificate (except such person be licensed to deal in game according to this act), shall sell or offer for sale any game to any person whatsoever, or if any person authorized to sell game under this act by virtue of a game certificate shall sell or offer for sale any game to any person whatsoever, except a person licensed to deal in game according to this act, every such offender shall, on conviction of any such offence before two justices of the peace, forfeit and pay for every head of game so sold or offered for sale any sum of money, not exceeding two pounds, as to the said justices shall seem meet, together with the costs of the conviction.

XXVI. Exceptions as to innkeepers.—Provided always, and be it further enacted, that it shall be lawful for any innkeeper or tavern-keeper, without any such licence for dealing in game as aforesaid, to sell game for consumption in his own house, such game having been procured from some person licensed to deal in game by virtue of this act, and not otherwise.

XXVII. Penalty on persons buying game except from licensed dealers.—And be it enacted, that if any person, not being licensed to deal in game according to this act, shall buy any game from any person whatsoever, except from a person licensed to deal in game according to this act, or *bonâ fide* from a person affixing to the outside of the front of his house, shop, or stall a board purporting to be the board of a person licensed to deal in game, every such offender shall, on conviction thereof before two justices of the peace, forfeit and pay for every head of game so bought such sum of money, not exceeding five pounds, as to the said justices shall seem meet, together with the costs of the conviction.

XXVIII. Penalty on licensed dealers buying game from uncertificated persons, or otherwise offending.—And be it enacted, that if any person, being licensed to deal in game according to this act, shall buy or obtain any game from any person not authorized to sell game for want of a game certificate, or for want of a licence to deal in game; or if any person, being licensed to deal in game according to this act, shall sell or offer for sale, any game at his house, shop, or stall, without such board as aforesaid being affixed to some part of the outside of the front of such house, shop, or stall at the time of such selling or offering for sale, or shall affix or cause to be affixed such board to more than one house, shop, or stall, or shall sell any game at any place other than his house, shop, or stall where such board shall have been affixed; or if any person not being licensed to deal in game according to this act, shall assume or pretend,

by affixing such board as aforesaid, or by exhibiting any certificate, or by any other device or pretence, to be a person licensed to deal in game; every such offender, being convicted thereof before two justices of the peace, shall forfeit and pay such sum of money, not exceeding ten pounds, as to the said justices shall seem meet, together with the costs of the conviction.

XXIX. *As to buying and selling game by the servants of a licensed dealer.*—Provided always, and be it enacted, that the buying and selling of game by any person or persons employed on the behalf of any licensed dealer in game, and acting in the usual course of his employment, and upon the premises where such dealing is carried on, shall be deemed to be a lawful buying and selling in every case, where the same would have been lawful if transacted by such licensed dealer himself: provided also, that nothing herein contained shall prevent any licensed dealer in game from selling any game which shall have been sent to him to be sold on account of any other licensed dealer in game.

XXX. *Penalty on persons trespassing in the daytime upon lands in search of game.*—Where the occupier of the land, not being entitled to the game, allows any person to kill it, the party entitled to the game may enforce the penalty.—And whereas after the commencement of this act, game will become an article which may be legally bought and sold, and it is therefore just and reasonable to provide some more summary means than now by law exists for protecting the same from trespassers: be it therefore enacted, that if any person whatsoever shall commit any trespass by entering or being in the daytime upon any land in search or pursuit of game, or woodcocks, snipes, quails, landrails, or conies, such person shall, on conviction thereof before a justice of the peace, forfeit and pay such sum of money, not exceeding two pounds, as to the justice shall seem meet, together with the costs of the conviction,* and that if any persons to the number of five or more together shall commit any trespass, by entering or being in the daytime upon any land in search or pursuit of game, or woodcocks, snipes, quails, landrails, or conies, each of such persons shall, on conviction thereof before a justice of the peace, forfeit and pay such sum of money, not exceeding five pounds, as to the said justice shall seem meet, together with the costs of the conviction: provided always, that any person charged with such trespass shall be at liberty to prove, by way of defence, any matter which would have been a defence to an action at law for such trespass; save and except that the leave and licence of the occupier of the land so trespassed upon shall not be a sufficient defence in any case where the landlord, lessor, or other person shall have the right of killing the game upon such land by virtue of any reservation or otherwise, as hereinbefore mentioned; but such landlord, lessor, or other person shall, for the purpose of prosecuting for each of the two offences herein last before-mentioned, be deemed to be the legal occupier

* At common law there is no necessity for the proof of "the entering and being" upon the land, and if a man shoots into the soil, or wilfully sends his dog upon it, he equally commits a trespass as if he went bodily himself.

of such land, whenever the actual occupier thereof shall have given such leave or licence; and that the lord or steward of the Crown of any manor, lordship, or royalty, or reputed manor, lordship, or royalty, shall be deemed to be the legal occupier of the land of the wastes or commons within such manor, lordship, or royalty, or reputed manor, lordship, or royalty.

XXXI. *Trespassers in search of game may be required to quit the land, and to tell their names and abodes, and in case of refusal may be arrested.—Penalty.—Party arrested must be discharged unless brought before a justice within 12 hours.*—And be it enacted, that where any person shall be found on any land, or upon any of his Majesty's forests, parks, chases, or warrens, in the daytime, in search or pursuit of game, or woodcocks, snipes, quails, landrails, or conies, it shall be lawful for any person having the right of killing the game upon such land, by virtue of any reservation or otherwise as hereinbefore mentioned, or for the occupier of the land (whether there shall or shall not be any such right by reservation or otherwise), or for any gamekeeper or servant of either of them, or for any person authorized by either of them, or for the warden, ranger, verderer, forester, master-keeper, under-keeper, or other officer of such forest, park, chase, or warren, to require the person so found forthwith to quit the land whereon he shall be so found, and also tell his Christian name, surname, and place of abode; and in case such person shall, after being so required, offend by refusing to tell his real name or place of abode, or by giving such a general description of his place of abode as shall be illusory for the purpose of discovery, or by willfully continuing or returning upon the land, it shall be lawful for the party so requiring as aforesaid, and also for any person acting by his order and in his aid, to apprehend such offender, and to convey him or cause him to be conveyed as soon as conveniently may be before a justice of the peace; and such offender (whether so apprehended or not), upon being convicted of any such offence before a justice of the peace, shall forfeit and pay such sum of money not exceeding five pounds, as to the convicting justice shall seem meet, together with the costs of the conviction: provided always, that no person so apprehended shall, on any pretence whatsoever, be detained for a longer period than twelve hours from the time of his apprehension until he shall be brought before some justice of the peace; and that if he cannot, on account of the absence or distance of the residence of any such justice of the peace, or owing to any other reasonable cause, be brought before a justice of the peace within such twelve hours as aforesaid, then the person so apprehended shall be discharged, but may nevertheless be proceeded against for his offence by summons or warrant, according to the provisions hereinafter mentioned, as if no such apprehension had taken place.

XXXII. *Penalty on persons found armed using violence, &c.*—And be it enacted, that where any persons, to the number of five or more together, shall be found on any land, or in any of his Majesty's forests, parks, chases, or warrens, in the daytime, in search or pursuit of game, or woodcocks, snipes, quails, landrails, or conies, any of such persons being then and there armed with a gun, and such persons or any of them shall then and there, by violence, intimidation, or menace, prevent or

endeavour to prevent any person authorized as hereinbefore mentioned from approaching such persons so found, or any of them, for the purpose of requiring them or any of them to quit the land whereon they shall be so found, or to tell their or his Christian name, surname, or place of abode respectively as hereinbefore mentioned, every person so offending by such violence, intimidation, or menace as aforesaid, and every person then and there aiding or abetting such offender, shall, upon being convicted thereof before two justices of the peace, forfeit and pay for every such offence such penalty, not exceeding five pounds, as to the convicting justices shall seem meet, together with the costs of the conviction; which said penalty shall be in addition to and independent of any other penalty to which any such person may be liable for any other offence against this act.

XXXIII. *Penalty for trespass in daytime in his Majesty's forests.*—And be it enacted, that if any person whatsoever shall commit any trespass, by entering or being in the daytime, upon any of his Majesty's forests, parks, chases, or warrens, in search or pursuit of game, without being first duly authorized so to do, such person shall, on conviction thereof before a justice of the peace, forfeit and pay such sum of money not exceeding two pounds, as to the justice shall seem meet, together with the costs of the conviction.

XXXIV. *What to be deemed daytime.*—And be it enacted, that for the purposes of this act the daytime shall be deemed to commence at the beginning of the last hour before sunrise, and to conclude at the expiration of the first hour after sunset.

XXXV. *The provisions as to trespassers not to apply to persons hunting, &c.*—Provided always, and be it enacted, that the aforesaid provisions against trespassers and persons found on any land shall not extend to any person hunting or coursing upon any lands with hounds or greyhounds, and being in fresh pursuit of any deer, hare, or fox already started upon any other land, nor to any person *bonâ fide* claiming and exercising any right or reputed right of free warren or free chase, nor to any gamekeeper lawfully appointed within the limits of any free warren or free chase, nor to any lord or any steward of the Crown of any manor, lordship, or royalty, or reputed manor, lordship, or royalty, nor to any gamekeeper lawfully appointed by such lord or steward within the limits of such manor, lordship, or royalty, or reputed manor, lordship, or royalty.

XXXVI. *Game may be taken from trespassers not delivering up the same when demanded.*—And be it enacted, that when any person shall be found by day or by night upon any land, or in any of his Majesty's forests, parks, chases, or warrens, in search or pursuit of game, and shall then and there have in his possession any game which shall appear to have been recently killed, it shall be lawful for any person having the right of killing the game upon such land, by virtue of any reservation or otherwise, as hereinbefore mentioned, or for the occupier of such land (whether there shall or shall not be any such right by reservation or otherwise), or for any gamekeeper or servant or either of them, or for any officer as aforesaid of such forest, park, chase, or warren, or for any person acting by the order and in aid of any of the said several persons, to demand from the person so found such game in his possession, and in

case such person shall not immediately deliver up such game, to seize and take the same from him, for the use of the person entitled to the game upon such land, forest, park, chase, or warren.

XXXVII. Application of penalties for offences against this act.—And be it enacted, that every penalty and forfeiture for any offence against this act (the application of which has not been already provided for) shall be paid to some one of the overseers of the poor, or to some other officer (as the convicting justice or justices may direct) of the parish, township, or place in which the offence shall have been committed, to be by such overseer or officer paid over to the use of the general rate of the county, riding, or division in which such parish, township, or place shall be situate, whether the same shall or shall not contribute to such general rate; and no inhabitant of such county, riding, or division shall be deemed an incompetent witness in any proceeding under this act by reason of the application of such penalty or forfeiture to the use of the said general rate as aforesaid.

XXXVIII. Time for payment of penalties, and scale of imprisonment for non-payment.—And be it enacted, that the justice or justices of the peace by whom any person shall be summarily convicted and adjudged to pay any sum of money for any offence against this act, together with costs, may adjudge that such person shall pay the same either immediately or within such period as the said justice or justices shall think fit, and that in default of payment at the time appointed such person shall be imprisoned in the common gaol or house of correction (with or without hard labour), as to the justice or justices shall seem meet, for any term not exceeding two calendar months where the amount to be paid, exclusive of costs, shall not amount to five pounds, and for any term not exceeding three calendar months in any other case, the imprisonment to cease in each of the cases aforesaid upon payment of the amount and costs.

XXXIX. Gives the form of conviction.

XL. Power to summon witnesses.—Penalty for disobedience of summons, &c.—And be it enacted, that it shall be lawful for any justice of the peace to issue his summons requiring any person to appear before himself, or any one or two justices of the peace, as the case may require, for the purpose of giving evidence touching any offence against this act; and if any person so summoned shall neglect or refuse to appear at the time and place appointed by such summons, and no reasonable excuse for his absence shall be proved before the justice or justices then and there present, or if any person appearing in obedience to such summons shall refuse to be examined on oath touching any such offence by the justice or justices then and there present, every person so offending shall, on conviction thereof before the said justice or justices, or any other justice or justices of the peace, forfeit and pay such sum of money, not exceeding five pounds, as to the convicting justice or justices shall seem meet.

XLI. Time for proceedings, and mode of enforcing the appearance of offenders.—And be it enacted, that the prosecution for every offence punishable upon summary conviction by virtue of this act shall be commenced within three calendar months after the commission of the offence;

and that where any person shall be charged on the oath of a credible witness with any such offence before a justice of the peace, the justice may summon the party charged to appear before himself, or any one or two justices of the peace, as the case may require, at a time and place to be named in such summons; and if such party shall not appear accordingly, then (upon proof of the due service of the summons by delivering a copy thereof to the party, or by delivering such copy at the party's usual place of abode to some inmate thereat, and explaining the purport thereof to such inmate), the justice or justices may either proceed to hear and determine the case in the absence of the party, or may issue his or their warrant for apprehending and bringing such party before him or them, as the case may be; or the justice before whom the charge shall be made may, if he shall have reason to suspect from information upon oath that the party is likely to abscond, issue such warrant in the first instance, without any previous summons.

XLII. *Prosecutor not required to prove a negative.*

XLIII. *Convictions to be returned to sessions.*

XLIV. *Appeal.*—And be it enacted, that any person who shall think himself aggrieved by any summary conviction in pursuance of this act may appeal to the justices at the next general or quarter sessions of the peace to be holden, not less than twelve days after such conviction, for the county, riding, division, liberty, franchise, city, or town, wherein the cause of complaint shall have arisen: provided, that such person shall give to the complainant a notice in writing of such appeal, and of the cause and matter thereof, within three days after such conviction, and seven clear days at the least before such sessions, and shall also either remain in custody until the sessions, or within such three days enter into a recognizance, with a sufficient surety, before a justice of the peace, conditioned personally to appear at the said sessions, and to try such appeal, and to abide the judgment of the court thereupon, and to pay such costs as shall be by the court awarded; and upon such notice being given, and such recognizance being entered into, the justice before whom the same shall be entered into shall liberate such person, if in custody; and the court at such sessions shall hear and determine the matter of the appeal, and shall make such order therein, with or without costs to either party, as to the court shall seem meet, and in case of the dismissal of the appeal, or the affirmance of the conviction, shall order and adjudge the offender to be dealt with and punished according to the conviction, and to pay such costs as shall be awarded, and shall, if necessary, issue process for enforcing such judgment.

XLV. *No certiorari, &c.*

XLVI. *This act not to preclude actions for trespass, but no double proceedings for the same trespass.*

XLVII. *Venue, &c. in proceedings against persons acting under this act.—Tender of amends.*

XLVIII. *Act not to extend to Scotland or Ireland.*

THE ACT 11 & 12 VICT. CAP. XXIX., TO ENABLE PERSONS TO KILL HARES IN ENGLAND AND WALES WITHOUT A GAME CERTIFICATE.

I. *Persons in the occupation of inclosed ground, and in certain cases owners, may kill hares without a game certificate.*—Whereas by an act passed, &c., &c. [preamble omitted], be it therefore enacted by the Queen's most excellent Majesty, by and with the advice and consent of the Lords spiritual and temporal, and Commons, in this present Parliament assembled, and by the authority of the same, that from and after the passing of this act it shall be lawful for any person, being in the actual occupation of any inclosed lands, or for any owner thereof who has the right of killing game thereon, by himself or by any person directed or authorized by him in writing, according to the form in the schedule to this act annexed, or to the like effect, so to do, to take, kill, or destroy any hare then being in or upon any such inclosed lands, without the payment of any such duties of assessed taxes as aforesaid, and without the obtaining of an annual game certificate.

II. *Authority to kill hares to be limited to one person at the same time in any one parish; which authority shall be sent to the clerk of the petty sessions, who shall register the same.*—If authority revoked, notice to be given of the same.—Provided always, and be it enacted, that no owner or occupier of land as aforesaid shall be authorized to grant or continue, under the provisions of this act, authority to more than one person, at one and the same time, to kill hares upon his land within any one parish; and that he shall deliver the said authority, or a copy thereof, or cause the same to be delivered, to the clerk of the magistrates acting for the petty sessions division within which the said lands are situate, who shall forthwith register the same, and the date of such registration in a book to be kept by him for such purpose, which book shall be at all reasonable times open to the inspection of the clerk of the commissioners acting in the execution of the acts for assessed taxes or of any of the collectors of assessed taxes within such district; and the said authority, so soon as it shall have been registered as aforesaid, shall be held good until after the first day of February in the year following that within which the same is granted, unless the same be previously revoked, and notice of such revocation be given to the clerk of the magistrates as aforesaid; and the said registered authority, or the unrevoked register thereof, shall be good and sufficient evidence of the right of the person to whom authority is given by the same to kill hares upon the lands mentioned within the same without having obtained an annual game certificate.

III. *Persons not to be liable to tax on gamekeepers.*—And be it enacted, that no person so directed or authorized to kill any hare as aforesaid shall, unless otherwise chargeable, be liable to any duties of assessed taxes as gamekeeper.

IV. *To extend to coursing or hunting.*—And be it enacted, that from and after the passing of this act it shall be lawful for any person to pursue and kill or to join in the pursuit and killing of any hare by coursing

of the lands or woods occupied by me in the parish of _____, county of _____, and commonly known as the farms or woods of _____; and in case of your so doing, I shall proceed against you as a wilful trespasser.

Witness my hand this _____ day of _____, 18 _____.

C. D.

N B.—In case the lands are in more than one parish or county, or both, it must be specified in the notice. If the notice is to warn off *rivers or waters*, then insert such words instead of *lands or woods*. In case of a joint occupancy, the notice must commence *We*, and for *me* and *I* in the body of it, *us* and *we* must be substituted. It must be signed by all the tenants. Newspaper notices are not legal services.

Those who require further information relative to the English Game Laws will be able to obtain it by referring to "Locke on the Game Laws," published by Shaw and Sons, Fetter-lane.

THE SCOTCH GAME LAWS.

Game in Scotland is greatly dependent upon common law, and is beyond my knowledge altogether, with the exception of the statutes which legalise the killing of hares, and the granting of certificates, and which settle the law of trespass. The important sections of the first of these are here appended, being distinct from the English law; the second is comprehended under the same statute with the English—viz, the Act 52nd Geo. III., cap. 93; and the third is the 2nd and 3rd Will. IV. c. 68, from which also I extract the chief sections. In Scotland it is a doubtful point whether the rentals paid for game are liable to the poor rates. There is a property qualification, but what it is I cannot say with anything like precision.

THE SCOTCH LAW RELATING TO HARES.

(11 & 12 VICT. CAP. XXX., TO ENABLE PERSONS TO KILL HARES WITHOUT A CERTIFICATE. JULY, 1848.)

I. *Any person having a right to kill hares in Scotland may do so without a game certificate, provided they shall be found on his own land.*—Whereas by an act passed, &c. &c. [preamble omitted]: be it therefore enacted by the Queen's most excellent Majesty, by and with the advice and consent of the Lords spiritual and temporal, and Commons, in this present Parliament assembled, and by the authority of the same, that from and after the passing of this Act it shall be lawful for any person having at present a right to kill hares in Scotland to do so

himself, or by any person permitted, directed, or commanded by him by any writing under his hand, without the payment of any such duties of assessed taxes as aforesaid, and without obtaining an annual game certificate: provided always, that such hares shall be found and killed in or upon his own land; provided also, that no person permitted, directed, or commanded as aforesaid shall have power to authorize any other person whatever to take or destroy any hare.

II. *Such persons not to be liable to tax on gamekeepers.*

III. *To extend to coursing or hunting.*—And be it enacted, that from and after the passing of this act it shall be lawful for any person to pursue and kill or to join in the pursuit and killing hares by coursing with greyhounds, or by hunting with beagles or other hounds, without the having obtained an annual certificate.

IV. *Not to permit the destruction of hares, &c., by poison.*

V. *Interpretation of act.*

VI. *Only to apply to Scotland.*

VII. *Act may be amended, &c.*

SCOTCH TRESPASS ACT.

(2 & 3 WILL. IV. CAP. LXVIII. AN ACT FOR THE MORE EFFECTUAL PREVENTION OF TRESPASSES IN PURSUIT OF GAME IN SCOTLAND. JULY 17th, 1832.)

I. *Penalty on persons trespassing in the daytime upon lands in search of game.*—Whereas trespasses upon property by persons unlawfully engaged in the pursuit of game have recently become frequent in various parts of Scotland, and have, in many cases, been attended by acts of violence and intimidation, for the repression of which the laws now in force in that part of the United Kingdom provide no sufficient remedy, and that it is therefore expedient that more effectual and summary remedies should be provided: be it therefore enacted by the King's most excellent Majesty, by and with the advice and consent of the Lords spiritual and temporal, and Commons, in this present Parliament assembled, and by the authority of the same, that if any person whatsoever shall commit any trespass by entering or being, in the day-time, upon any land, without leave of the proprietor, in search or pursuit of game, or of deer, roe, woodcocks, snipes, quails, landrails, wild ducks, or conies, such person shall, on being summarily convicted thereof before a justice of the peace, on proof on oath by one or more credible witness or witnesses, or confession of the offence, or upon other legal evidence, forfeit and pay such sum of money, not exceeding two pounds, as to the justice shall seem meet, together with the costs of the conviction; and that if any person having his face blackened, coloured, or otherwise disfigured for the purpose of disguise, or if any persons, to the number of five or more together, shall commit any trespass by entering or being, in the day-time, upon any land in search or pursuit of game, or of deer, roe, woodcocks, snipe, quails, landrails, wild ducks, or conies, each of such persons shall, on being summarily convicted thereof before a justice of the peace on proof on oath by one or more credible witness or witnesses,

or confession of the offence, or upon other legal evidence, forfeit and pay such sum of money, not exceeding five pounds, as to the said justice shall seem meet, together with the expenses of process. Provided always, that any person charged with any such trespass shall be at liberty to prove, by way of defence, any matter which should have been a defence to an action at law for such trespass.

II. *Such trespassers may be required to quit the land, and to give their names and abodes; and in case of refusal may be arrested.—Penalty.—Party arrested must be discharged, unless brought before a justice within 12 hours.*—And be it enacted, that where any person shall be trespassing on any land, in the day-time, in search or pursuit of game, or woodcocks, snipes, quails, landrails, wild ducks, or conies, it shall be lawful for any person having the right of killing the game upon such land, or for the occupier of the land, or for any gamekeeper or servant of either of them, or for any person authorized by either of them, to require the person so trespassing forthwith to quit the land whereon he shall be so trespassing, and also to tell his christian name, surname, and place of abode; and in case such person shall, after being so required, offend by refusing to tell his real name or place of abode, or by giving such a general description of his place of abode as shall be illusory for the purpose of discovery, or by wilfully continuing or returning upon the land, it shall be lawful for the party so requiring as aforesaid, and also for any person acting by his order and in his aid, to apprehend such offender, and to convey him, or cause him to be conveyed, as soon as conveniently may be, before a justice of the peace; and such offender (whether so apprehended or not), upon being summarily convicted of any such offence before a justice of the peace, at the instance of the owner or occupier of such land, or of the procurator fiscal for the county, on proof on oath by one or more credible witness or witnesses, or confession of the offence, or upon other legal evidence, shall forfeit and pay such sum of money, not exceeding five pounds, as to the convicting justice shall seem meet, together with expenses of process: provided always, that no person so apprehended shall on any pretence whatsoever be detained for a longer period than twelve hours from the time of his apprehension until he shall be brought before some justice of the peace; and that if he cannot, on account of the absence or distance of the residence of any such justice of the peace, or owing to any other reasonable cause, be brought before a justice of the peace within such twelve hours as aforesaid, then the person so apprehended shall be discharged at the end of that time, but may nevertheless be proceeded against for his offence by summons or warrant, according to the provisions herein-after mentioned, as if no such apprehension had taken place.

III. *What to be deemed day-time.*—And be it enacted, that for the purposes of this act the day-time shall be deemed to commence at the beginning of the last hour before sunrise, and to conclude at the expiration of the first hour after sunset.

IV. *The provisions as to trespassers not to apply to persons hunting, &c.*

V. *Game may be taken from trespassers not delivering up the same when demanded.*

VI. *Penalty on aggressors for assaulting any one executing this act, not exceeding 5*l.*, or in default imprisonment with hard labour for three months.*

VII. *Application of penalties.*

VIII. *Justices to fix the time for payment of penalties.—Imprisonment for non-payment.*

IX. *Form of conviction.*

X. *Power to summon witnesses.—Penalty for disobedience of summons, &c.*

XI. *As to prosecutions for offences.*

XII. *Prosecutor not required to prove a negative.*

XIII. *Convictions to be returned to sessions, and kept as evidence.*

XIV. *Appeal.*

XV. *Convictions, &c., not to be quashed for want of form, or removable by advocacy, &c.*

XVI. *This act not to preclude actions for trespass; but no double proceedings shall be had for the same trespass.*

XVII. *Venue.—Notice of action.—Tender of amends.*

XVIII. *Limits of act, Scotland.*

THE IRISH GAME LAWS.

These are in a still more unsettled state than the corresponding laws in Scotland; and in this part of the United Kingdom a certificate must be obtained for killing hares. The Irish game laws are spread through a long list of statutes, commencing with the reign of Richard II. Hence it is no wonder that there is now an agitation for their consolidation into one act, like 1st and 2nd William IV., c. 32. In Ireland a certificate is useless, unless the shooter has freehold or personal property of the specified amount. Without this, even if he should rent an enormous tract of land, he cannot kill a single head of game, nor has he the power of appointing a gamekeeper to preserve it, and shoot for the use of the house, unless he is lord of a manor and an esquire.

The following are the variations in the law relating to the game itself from that prevailing in England. Landrail and quail are added to the English list of game. Woodcocks and snipe require a licence. The season for shooting pheasants commences on the 1st of September; grouse on the 20th of August; and partridges, landrail, and quail on the 20th of September, or nearly three weeks after pheasants. Hares cannot be sold between the first Monday in November and the first Monday in every July; but they may be killed at

any season. Eggs are protected in the same way as in England.

The qualification necessary to kill game is twofold, being dependent, *firstly*, upon the possession of *property* to a definite amount; and *secondly*, upon a game certificate. An English game certificate is sufficient for Ireland, and one obtained in the latter country will avail for England, on paying the difference between the two, amounting to 17s. 10d. The property qualification consists in a freehold estate of 40l. a year, or personal estate to the value of 1000l. *Shooting dogs* (other than whelps) may not be kept by any one who does not possess a freehold estate of the annual value of 100l., or a personal estate of the value of 1000l.

The property in game depends upon manorial and other rights, too complicated for insertion here.

Gamekeepers can only be appointed by a lord of a manor, who must also be not lower in rank than an esquire independent of the lordship. Esquires (in law) are the sons of peers during the lifetime of their fathers; eldest sons of younger sons of peers, and their eldest sons; all noblemen of other nations, and Scotch and Irish peers, not being knights; eldest sons of baronets and knights, and their eldest sons for ever; esquires created especially with a collar of SS., and spurs of silver; persons created esquires by letters patent; esquires of knights of the Bath; barristers at law and justices of the peace, except those of corporate towns.

The law of trespass is still more uncertain than that of England; but for particulars of this, as well as all other matters not here mentioned, I must refer my readers to a most useful treatise on the game laws of Ireland, by E. P. Levinge, Esq., Barrister-at-Law, published by E. J. Millikin, 15, College-green, Dublin.

23 & 24 VICT. CAP. XC. AN ACT TO REPEAL THE DUTIES ON GAME CERTIFICATES AND CERTIFICATES TO DEAL IN GAME, AND TO IMPOSE IN LIEU THEREOF DUTIES ON EXCISE LICENCES AND CERTIFICATES FOR THE LIKE PURPOSES. (13th AUGUST, 1860.)

Be it enacted by the Queen's most excellent Majesty, by and with the advice and consent of the Lords Spiritual and Temporal, and Commons, in this present Parliament assembled, and by the authority of the same as follows:

I. *After passing of this Act the duties in respect of certificates to kill and deal in game as contained in 52 G. 3. c. 93., Sched. (L.), 56 G. 3. c. 56., and 1 & 2 W. 4. c. 32. repealed.*—From and after the passing of this Act the respective duties of assessed taxes, now payable under the several Acts of Parliament in that behalf in respect of certificates to kill game in Great Britain, and to deal in game in England, and all the provisions, rules, and directions for assessing, charging, and collecting any of the said duties contained in Schedule (L.) of the Act passed in the 52nd year of Geo. III., c. 93., and also the duties now payable in Ireland under the Act passed in the 56th year of Geo. III., c. 56., in respect of every certificate of having registered a deputation as a gamekeeper, and in respect of every certificate to authorize any person, not being a gamekeeper, to kill game in Ireland, and also the 19th and 20th sections of the Act passed in the 1st and 2nd years of Wm. IV., c. 32., shall respectively cease and determine, and the same are hereby repealed, except as to any arrears of the said duties respectively, and as to any penalties incurred before the commencement of this Act.

II. *In lieu of duties repealed, the duties herein-named to be levied.*—In lieu of the duties hereby repealed there shall be granted, charged, and paid for and upon the several licences and certificates to take or kill game, and licences to deal in game hereinafter mentioned, the respective duties or sums of money hereinafter expressed or denoted; (that is to say,)

£ s. d.

For a licence in Great Britain or a certificate in Ireland to be taken out by every person who shall use any dog, gun, net, or other engine for the purpose of taking or killing any game whatever, or any woodcock, snipe, quail, or landrail, or any conies, or any deer, or shall take or kill by any means whatever or shall assist in any manner in the taking or killing by any means whatever of any game, or any woodcock, snipe, quail, or landrail, or any coney, or any deer: If such licence or certificate shall be taken out after the 5th day of April and before the 1st day of November,

To expire on the 5th day of April in the following year	3	0	0
To expire on the 31st day of October in the same year in which the licence or certificate shall be taken out	2	0	0

	£ s. d.
If such licence or certificate shall be taken out on or after the 1st day of November,	
To expire on the 5th day of April following	- 2 0 0
Provided always, that any person having the right to kill game on any lands in England or Scotland shall be entitled to take out a licence to authorize any servant for whom he shall be chargeable to the duty of assessed taxes as a gamekeeper, to kill game upon the same lands, upon payment of the duty of	- 2 0 0
And for every licence to deal in game in England, Scotland, or Ireland, to be granted under this Act	2 0 0

III. *Duties granted to be excise duties under the Commissioners of Inland Revenue.*—The duties by this Act granted shall be under the management of the Commissioners of Inland Revenue, and shall be deemed to be excise duties, and all the powers, provisions, clauses, regulations, and directions contained in any Act relating to excise duties or to penalties under Excise Acts, and now or hereafter in force, shall respectively be of full force and effect with respect to the duties by this Act granted, and to the penalties hereby imposed, so far as the same are or may be applicable, and shall be observed, applied, and enforced for and in the collecting, securing, and recovering of the said duties and penalties hereby granted and imposed respectively, and otherwise in relation thereto, so far as the same shall be consistent with and not superseded by the express provisions of this Act, as fully and effectually as if the same had been herein repeated and specially enacted in this Act with reference to the said last-mentioned duties and penalties respectively.

IV. *Licence to be taken out for taking or killing game in Great Britain.—Penalty for neglect.*—Every person before he shall in Great Britain take, kill, or pursue or aid or assist in any manner in the taking, killing, or pursuing by any means whatever, or use any dog, gun, net, or other engine for the purpose of taking, killing, or pursuing any game, or any woodcock, snipe, quail, or any landrail, or any coney, or any deer, shall take out a proper licence to kill game under this Act, and pay the duty hereby made payable thereon; and if any person shall do any such act as hereinbefore mentioned in Great Britain without having duly taken out and having in force such licence as aforesaid, he shall forfeit the sum of twenty pounds.

V. *Exceptions and exemptions.*—The following exceptions and exemptions from the duties and provisions of this Act are hereby made and granted; (that is to say,)

Exceptions.

1. The taking of woodcocks and snipes with nets or springes in Great Britain.
2. The taking or destroying of conies in Great Britain by the proprietor of any warren or of any inclosed ground whatever, or by the tenant of lands, either by himself or by his direction or permission.
3. The pursuing and killing of hares respectively by coursing with greyhounds, or by hunting with beagles or other hounds.

4. The pursuing and killing of deer by hunting with hounds.
5. The taking and killing of deer in any inclosed lands by the owner or occupier of such lands, or by his direction or permission.

Exemptions.

1. Any of the Royal Family.
2. Any person appointed a gamekeeper on behalf of Her Majesty by the Commissioners of Her Majesty's woods, forests, and land revenues, under the authority of any Act of Parliament relating to the land revenues of the Crown.
3. Any person aiding or assisting in the taking or killing of any game, or any woodcock, snipe, quail, landrail, or coney, or any deer, in the company or presence and for the use of another person who shall have duly obtained, according to the directions of this Act, and in his own right, a licence to kill game, and who shall by virtue of such licence then and there use his own dog, gun, net, or other engine for the taking or killing of such game, woodcock, snipe, quail, landrail, coney, or deer, and who shall not act therein by virtue of any deputation or appointment.
4. And, as regards the killing of hares only, all persons who, under the provisions of the two several Acts, 11th and 12th Vict. c. 29. and c. 30. respectively, are authorized to kill hares in England and Scotland respectively, without obtaining an annual game certificate.

VI. *Nothing herein to alter 11 and 12 Vict. cc. 29. and 30., except that "game certificate" in said Acts, and also in 1 and 2 W. 4. c. 32., shall be read as "licence to kill game."*—Provided always, that nothing herein contained shall extend to repeal, alter, or affect any of the provisions of the said two several Acts of the 11th and 12th years of Her Majesty, cc. 29. and 30., further than that the term, "game certificate" in the said Acts respectively used shall be construed to mean a licence to kill game under the provisions of this Act, and shall be so read accordingly; and that the term "game certificate" used in the Act of the 1st and 2nd years of Wm. IV., c. 32., shall be construed and read in like manner; and that wherever in the said last-mentioned Act the duty of three pounds thirteen shillings and sixpence on a game certificate is mentioned, the duty of three pounds on a licence to kill game shall be read in lieu.

VII. *Licences may be taken out on behalf of assessed servants acting as gamekeepers for persons having right to kill game, or under deputations from Lords of manors.*—Any person having the right to kill game on any lands in England or Scotland, and being charged or liable to be charged to the assessed tax on servants in respect of any gamekeeper, by whomsoever deputed or appointed, and whether deputed or appointed or not, and any person granting a deputation or appointment in Great Britain to the servant of any other person who shall be duly charged to the assessed tax on servants in respect of such servant, whether as gamekeeper or in any other capacity, with power and authority to take or kill any game, shall respectively be at liberty to take out a licence to kill game on behalf of any such servant, on payment of

the duty of two pounds for the year ending on the 5th day of April, and such licence shall exempt the servant named therein during his continuance in the same capacity and service, and on his quitting such service shall also exempt any servant who shall succeed him in the same service and capacity, or who shall succeed to the deputation of the same manor or royalty or lands within the year for which the licence is granted, during the remainder of such year; and no such servant on whose behalf a licence shall have been duly obtained as aforesaid shall be required to obtain a licence for himself, or be liable to any penalty by reason of not obtaining a licence in his own name.

VIII. *On change of gamekeeper, or revocation of deputation, licence may be continued to successor.*—Every such licence to kill game taken out on behalf of any such servant as aforesaid shall, upon the revocation of any such deputation or appointment, or on his quitting the service of the master by whom such licence shall have been taken out, be from thenceforth of no further effect as to the person named therein as such servant, or so deputed or appointed as aforesaid; but if within the year for which such licence was granted the said master, on the quitting of such servant, shall employ another servant as gamekeeper in his stead, or the person by whom such deputation or appointment was made shall on the revocation thereof make a new deputation or appointment to any person in his service, or in the service of the same master by whom such licence shall have been taken out, and who shall have been charged or be chargeable to the said assessed tax on servants as aforesaid, the officer by whom such licence was granted, or the proper officer appointed by the commissioners in that behalf, shall renew such licence for the remainder of that year, on behalf of the fresh servant or the person so newly appointed, as the case may be, without payment of any further duty, by indorsing on such licence the name and place of abode of the said last-mentioned servant, or the person to whom such last-mentioned deputation or appointment shall have been granted, and declaring the same to be a renewed licence free of duty.

IX. *Such licences not available for acts done out of limits of the manor or lands for which the parties are appointed gamekeepers.*—Provided always, that no such licence taken out for or on behalf of any person, being such servant or acting under a deputation or appointment as aforesaid, shall be available for such person in any suit or prosecution where proof shall be given of his doing or having done any act for which a licence is required under this Act on land on which his master had not a right to kill game.

X. *Persons doing any act requiring a licence to kill game, to produce the same, on demand, or declare their names, places of residence, &c.*—*Penalty for refusal.*—If any person shall be discovered doing any act whatever in Great Britain in respect whereof a licence to kill game is required under this Act, by any officer of Inland Revenue, or by any Lord or gamekeeper of the manor, royalty, or lands wherein such person shall then be, or by any person having duly taken out a proper licence to kill game under this Act, or by the owner, landlord, lessee, or occupier of the land on which such person shall then be, it shall be lawful for such officer or other person aforesaid to demand and require from the person so act-

ing the production of a licence to kill game issued to him; and the person so acting is hereby required to produce such licence to the person so demanding the production thereof, and to permit him to read the same, and (if he shall think fit) to take a copy thereof or of any part thereof; or in case no such licence shall be produced to the person demanding the same as aforesaid, then it shall be lawful for the person having made such demand to require the person so acting forthwith to declare to him his christian and surname and place of residence, and the place at which he shall have taken out such licence; and if such person shall, after such demand made, wilfully refuse to produce and show a licence to kill game issued to him, or in default thereof as aforesaid to give to the person so demanding the same his christian and surname and place of residence, and the place at which he shall have taken out such licence, or if he shall produce any false or fictitious licence, or give any false or fictitious name or place, or if he shall refuse to permit any licence which he may produce to be read, or a copy thereof or of any part thereof to be taken, he shall forfeit the sum of twenty pounds.

XI. *Licence to be void if party be convicted of any offence under 1 & 2 W. 4. c. 32. or 2 & 3 W. 4. c. 68.*—If any person, having obtained a licence to kill game under this Act, shall be convicted of any offence under section 30 of the said Act of the 1st and 2nd years of Wm. IV., c. 32., or under the Act of the 2nd and 3rd years of Wm. IV., c. 68., the said licence shall thenceforth be null and void.

XII. *Commissioners to publish lists of persons licensed to kill game.*—The Commissioners of Inland Revenue shall, when and as they shall see fit, cause lists of the names and residences of the several persons to or for whom licences to kill game have been granted under this Act to be inserted in such newspapers or published in such other manner as to them shall seem proper, distinguishing in such lists the persons acting under any deputation, appointment, or authority from others, and the manors, royalties, or lands for which deputations, appointments, or authorities have been granted, and also distinguishing the rate of duty paid for such licences.

XIII. *Provisions of 1 & 2 W. 4. c. 32. and 2 & 3 Vict. c. 35., relating to licences to deal in game to be in force throughout the United Kingdom.*—All the clauses and provisions of the two several Acts passed respectively in the 1st and 2nd years of Wm. IV. c. 32., and the 2nd and 3rd years of Her present Majesty, c. 35., relating to the granting of licences by Justices of the Peace to deal in game, and to the holding of special sessions by such Justices in their respective divisions or districts for the purpose of granting such licences, and also all the clauses, provisions, and penalties contained in the said Acts or either of them relating to dealers in game, and to the selling of game, either by or to such dealers or others, shall, so far as the same are consistent with the express provisions of this Act, and as the same are altered or amended by this Act, extend to and be of full force and effect in and throughout the whole of the United Kingdom, and shall be observed, applied, and enforced as if the same, so altered or amended and made consistent with the express provisions of this Act, had been herein repeated and specially enacted: provided always, that no person shall be authorized to sell game to any

licensed dealer unless he shall have taken out a three pound licence under this Act.

XIV. *Persons licensed by the Justices to deal in game, to pay for and obtain a licence under this Act.*—Every person who shall have obtained any licence to deal in game from the Justices of the Peace, under the provisions of the said two several Acts in the preceding clause mentioned, shall annually, and during the continuance of such licence, and before he shall be empowered to deal in game under such licence, obtain a further licence to deal in game under this Act, on payment of the duty hereby charged thereon, and if any person obtaining a licence from the said Justices as aforesaid shall purchase or sell or otherwise deal in game before he shall obtain a licence to deal in game under the provisions of this Act, he shall forfeit the sum of twenty pounds.

XV. *Licences to deal in game under this Act to be granted only to those who have obtained licences from the Justices.*—*List of persons licensed to be kept for inspection.*—Provided always, that no licence to deal in game shall be granted under the provisions of this Act to any person, except upon the production of a licence for the like purpose duly granted to him by the Justices of the Peace, as aforesaid, and then in force; and every officer appointed or authorized to grant licences to deal in game under this Act shall in each year make out a list, to be kept in his possession, containing the name and place of abode of every person to whom he shall have granted or issued a licence to deal in game under this Act, and such officer shall at all reasonable hours produce such list to any person making application to inspect the same, and shall be entitled to demand and receive for such inspection the sum of one shilling.

XVI. *By whom licences shall be granted, and form thereof.*—*Duration and expiration of licences.*—All licences and certificates to kill game and to deal in game respectively, under the provisions of this Act, shall be in such form as the Commissioners of Inland Revenue shall from time to time provide in that behalf, and shall denote the amount of duty charged thereon respectively, and shall be granted, signed, and issued at the chief office of Inland Revenue in London, Edinburgh, and Dublin respectively, and by the several supervisors of Excise in their respective districts, or by such other officers of Inland Revenue and at such places as the said Commissioners shall think fit to employ and appoint respectively in that behalf; and every such licence shall contain the proper christian and surname and place of residence of the person to whom the same shall be granted, with any other particulars which the Commissioners of Inland Revenue may direct to be inserted therein, and shall be dated on the day when the same was actually issued, and shall have effect and be in force upon the day of the issuing thereof, and shall expire on the day therein mentioned for the termination thereof.

XVII. *5 & 6 Vict. c. 81. relating to game certificates in Ireland to continue in force.*—All the clauses, powers, provisions, and regulations, pains and penalties, contained in or imposed by the Act passed in the 5th and 6th years of Her Majesty's reign, c. 81., relating to certificates to kill game in Ireland shall be of full force and effect and shall be applied in Ireland to the certificates to be granted under this Act and the duties hereby imposed thereon, as fully and effectually as if the same were

herein repeated and specially enacted in reference to such last-mentioned certificates and duties.

XVIII. *Licences and certificates to be available throughout the United Kingdom.*—Every licence and certificate to kill game taken out respectively in Great Britain and Ireland under this Act, by or on behalf of any person in his own right, and not as a gamekeeper or servant, shall be available for the killing of game in any part of the United Kingdom.

XIX. *7 & 8 G. 4. c. 49. repealed.*—The Act passed in the 7th and 8th years of Geo. IV., c. 49., intituled "An Act to exempt persons who have procured game certificates in Great Britain from the duty on game certificates in Ireland, and to authorize the persons who have paid duty on game certificates in Ireland to kill game in Great Britain, upon paying the additional duty only," shall be and the same is hereby repealed.



INDEX.

- ABERDEENSHIRE**, deer forests of, 100
Accessories for grouse-shooting, 25, 27; for deer-stalking, 101
Accidents, safety from, 303
Accoutrements for partridge-shooting, 27, 44
Adams's breech-loading gun, 267
Aim, directions for taking, 3; the term explained, 320
Animals employed by the shooter, 113 *et seq.* (*see* Dogs)
Antimony, black, percussion caps made of, 207
Argyleshire, deer forests of, 100
Aston's breech-loading gun, 267
Attitude in shooting, 12
- BACKING**, the point to be taught the shooting-dog, 124, 129
Balls, their velocity greatest at the moment of leaving the muzzle, 313; theory of their velocity, 313-16; different kinds of, 327 *et seq.*; Whitworth's, 330, 331; varieties of, 333; crenulated and plain cylindro-conoidal ones, 334; moulds for, 369; casting of, 369, 370; patches for, 370; manufacture of cartridges for, 372; round and conical, their respective advantages and disadvantages, 382, 383
- Barn-owls, destructive to game**, 423; their natural habits, 423, 424
Barrels of shot-guns, 171; their manufacture 213; different qualities of metal, *ib.*; iron of Damascus, 214; Damascus barrels, 215, 216; stub-twist, 216; laminated iron, and stub-Damascus, 217; charcoal iron, 218; two-penny iron, 219; sham-dam, *ib.*; forging the iron into, 220; different breadth of rod, *ib.*; boring and grinding, 221; nicety required in putting them together, 222, 223; proving of, 224-7; proof-marks, 226; gauge size to be struck on them all, 227; browning, case-hardening, &c., 231; of the muzzle-loading percussion gun, 233; firmness of, 250; cleaning the, 251, 253; of the breech-loading gun, 259; of Needham's needle-gun, 273; of Lancaster's needle-gun, 281; length of, 302; of rifles, 317; single and double, 335
- Bastin's breech-loading gun**, 264; the cartridge case, 266; objections to, 266, 267; breech-loading rifle, 353
Battue-shooting, 59
Bean goose, the, 84
Beat, management of the, for grouse-shooting, 27; for partridge-shooting, 44; the old-fashioned mode, 45
Beaters for driving pheasant coverts, 58
Bernicle goose, 87
Birds found on our southern manors, 32 *et seq.*; partridges, 32, 542; the quail, 35; the landrail, 36; the crane and the plover, 38, 39; the dotterel and the grey plover, 40; the peewit, 41; trapping of, 437, 438

- Black-game, shooting of, 29; difficulty of breeding, 394
 Black grouse, 16
 Blenheims, originally known as cockers, 137
 Blue hawk, destructive to game, 418
 Blue rock pigeon, the best for trap-shooting, 11
 Bolt of Needham's needle-gun, 277
 Boring of shot-gun barrels, 177, 221
 Boucher's theory of the velocity of bullets, 313-16; his muzzle-loading rifle, 325-330; his letter on, 326
 Box-trap for catching vermin, 432; ground plan of, 433
 Breaking of pointers and setters, 118; at pairing time, without the gun, 124; autumnal completion of, 181; remedies for faults in, 133; of field spaniels, 135, 139
 Breech of a shot-gun, 224; of the muzzle-loading percussion cap, 233; Joe Manton's, 234; on the form of the, 235; adapting the nipple to the, 236; Greener-Horton's, 237; of Lancaster's needle-gun, 283, 284.
 Breech and bolt of the breech-loading gun, 262
 Breech-loading guns, the best for partridge-shooting, 44; general principles of, 254; Lefauchaux gun, 253-263; the cartridge, 258; the barrel, 259; Baston's breech-loader, 264; Adams's, 267; Aston's and Dougall's, 267-9; Needham's needle-gun, 271; Lancaster's needle-gun, 280; Chateauvillier's gun, 287; on the choice of, 290; cartridge cases for, 291; cleaning, 296; Bussey's cartridge-holder, 297; punt-guns, 299; advantages and disadvantages of, as compared with muzzle-loaders, 309, 310; manufacture of cartridges for, 374; different requisites of the, 379; choice of, 381
 Breech-loading rifles, applicable to sporting purposes, 336 *et seq.*; their advantages, 355 (*see* Sporting rifle)
 Breech-plug and lock of Needham's needle-gun, 272, 274
 Brent goose, 85
 Brown, Capt., his discovery in the improved use of gunpowder, 202
 Browning of shot-gun barrels, 231, 232
 Bullets (*see* Balls)
 Burrough duck, the, 86
 Bursting, safety from, 309
 Bushing, the best protection for partridges against poaching, 447
 Bussey's cartridge-holder, 297
 Buzzard, destructive to game, 416
- CALIBRE of the shooting-gun, 171
 Callisher's breech-loading rifle, 340-4
 Capercaille, a variety of grouse, 15, 21
 Cap-holder, representation of the, 211
 Caps (*see* Percussion caps)
 Carrion crow, destructive to game, 426
 Carrying, fondness for, displayed by some puppies, 146
 Cartridge-cases of the breech-loading gun, 260; loading and filling of, 291, 293; Imlock and Harris's method, 292, 295; Jeffries' method, 293; recapping machine for, 295; Lancaster's method, *ib.*
 Cartridge-holders useful auxiliaries to breech-loading guns, 297
 Cartridges, explosive, preparation of, 204; different makers of, 209; two kinds of, 210; for loading percussion guns, 245, 246; patent ones, 246, 247; comparative effects of the loose charge, 249; strength of, *ib.*; of Needham's needle-gun, 278; of Lancaster's gun, 281, 285, 286; of Chateauvillier's, 289; prepared by Mr. Prince, 339; by Captain Hayes, *ib.*; for the breech-loading rifles, 350, 351, 353, 354, 357, 360; manufacture of, for rifle balls, 372; for breech-loaders, 374

- Case-hardening of shot-gun barrels, 231 ; process of, 232
 Casting of balls, 207 ; of shot, 208, 269
 Cats, destructive to game, 407 ; best mode of trapping, 435
 Certificates for the gamekeepers, 394-97 ; for the killing of game, act for repealing and regulating, 475 *et seq.*
 Ceylon, sporting in, 384
 Chamber of Lancaster's needle-gun, 283
 Charcoal iron, the best quality for inferior guns, 218
 Charge of the percussion gun, 244 ; comparative effects of the loose charge and the cartridge, 249 ; efficiency of the, 250
 Chateauvillier's needle-gun, 287 ; principles of, with illustrations, 288, 289, 290
 Chlorate of potash and sulphur used as an explosive material, 206
 Cleaning-rod for muzzle-loading guns, 212
 Cleaning the percussion gun, 251 ; the locks, 252 ; breech-loading guns, 296
 Clumber spaniel, the, 136
 Cock of the wood, a variety of grouse, 15
 Cocker, a field spaniel used for hunting the woodcock, 135 ; the Devonshire and the Welsh cocker, 136
 Cock-shooting, 62 *et seq.* ; dogs employed in, 70 (*see* Woodcock)
 Colt's revolvers, 363
 Conolly, Captain, his rest for target practice, 378
 Coot, characteristics and natural habits of the, 83
 Coursing, laws respecting, 468
 Covert-shooting, 56 *et seq.* ; different kinds of—the pheasant, 56, 58 ; the hare, 57 ; the covert-gun, 59 ; the battue, *ib.* ; the wild pheasant, 61 ; the hedge-row pheasant, 62 ; cock-shooting, 62, 70 ; the woodcock, 64 *et seq.* ; rabbit-shooting, 75
 Coverts for pheasant-shooting, 58 ; the fashion to drive with beaters, *ib.*
 Crane, the spotted, and little, 38
 Cramp, game subject to, 406
 Cross-breeds for retrieving, 144, 145
 Crows, different kinds of, destructive to game, 426, 427
 Curlew, the, 86
 Cylinder of Dean's revolver, 365
- DAMASCUS barrels for shot-guns, 215 ; imitation Damascus, 216 ; stub-Damascus, 217
 Damascus iron, bar of, 214
 Dandie Dimmont terrier, 151
 Daw's breech-loading gun, 270
 Dead mark, learning to hit a, 4
 Dean's revolving rifle, 364 ; lock, cylinder, and trigger of, 365
 Decoy-duck shooting, 92
 Deer, the, 96, 99
 Deer forests of Scotland, 99
 Deerhound, 101, 143 ; entering of the, 144
 Deer-shooting, rifle for, 385 ; vulnerable parts of the deer, *ib.*
 Deerstalking, 105 ; Mr. Scrope's account of, 105, 106 *et seq.* ; double quick and driving, 111.
 Definitive proof marks, 225-7
 Detonating powders, 204 ; their rapidity of combustion, 111
 Disc bullet, 328
 Diseases of ferrets, 155 ; of game, and their cure, 404, 405
 Divers, the, 86
 Dogs, the best ones for grouse-shooting, 23, 24 ; number of required, 29 ; em-

- ployed for partridge-shooting, 43; the pointer, *ib.*; for snipe-shooting, 53; for pheasant-shooting, 58; for cock-shooting, 70; for rabbit-shooting, 77; for wild-fowl shooting, 89; for deer-stalking, 101; used by the shooter, 113 *et seq.*; pointers, 113; setters, 115; breaking them in, 118, 119; preparatory education of, 120; breaking at pairing time without the gun, 124; autumnal completion of breaking, 131; remedies for faults, 133; field spaniels, and their breaking, 135, 139; retrievers and retrieving, 143; rabbit terriers, 150; general management of for shooting, 158; kennels and kennel management, *ib.*; feeding, 160; dressing and physic of, 161; preparation for working them, and management after work, 166, 167
- Dotterel, characteristics of the, 40
- Double-quick deer-stalking, 111
- Dougall's breech-loading gun, 267; graphic illustrations of, 268, 269
- Dovehawk, destructive to game, 418
- Drawing, one of the points to be taught the shooting-dog, 124, 130
- Dress-for grouse-shooting, 25; for partridge-shooting, 44; for snipe-shooting, 54
- Dressing and physic for shooting dogs, 161; various applications for the destruction of parasitical and other vermin, 162, 163
- Driving, in deer stalking, 111
- Drop-shot, different sizes, 208, 209
- Duck, different varieties of, 86
- pintailed, its natural habits, 81
- wild, its natural habits, 78; young broods of the, 89
- Duck-gun, breech-loading, 299
- Duck and punt guns, 87
- Duck-hawk, destructive to game, 416
- Dunbird, the, 81
- EAGLE, destructive to game, 418
- Eccentric bolt of Dougall's breech-loading gun, 269
- Eley's cartridges, 7; his patent wire cartridges, 246
- Education of shooting dogs, preparatory to training, 120-4, 133, 138
- Egg-destroyers, trapping of, 438, 439
- Eggs of pheasants, methods of obtaining, 395
- different modes of obtaining, 396
- Eider duck, the, 86
- Eley and Joyce, chief makers of percussion caps in England, 206
- Enfield muzzle-loading rifle, 323
- Entering and breaking the spaniel, 139
- Eprouvettes, employed for estimating the explosive power of gunpowder, 186, 187
- Erskine's breech-loading gun, 267
- Excise duties, act for the regulation of, 475, 476
- Exploding, modes of, 174
- Explosion of gunpowder, 178, 179
- Explosive compounds, action of, 178 *et seq.*
- FALCONS, destructive to game, 415, 419
- Fallow-deer, the, 99
- Faults in shooting dogs, remedies for, 133, 134
- Feather-edged groove, 338
- Feeding, of shooting dogs, 160
- Fens of Great Britain, 53
- Ferretting, instructions in, 155
- Ferrets used in aid of the gun in rabbiting, 152; rearing and feeding,

- their hutches, *ib.*; their breeding, 154; diseases of, 155; management of, in ferreting, *ib.*
- "Field" gun, trial of, in 1859, 303; table of the performances and result, 304, 305
- "Field" rifle, its advantages in breech-loading, 355; description and representations of the, 356
- Field spaniels (*see* Spaniels)
- Flapper shooting, 89
- Flasks (*see* Powder-flasks)
- Fleas, how to kill, 162
- Flight of the snipe, its eccentricity, 54
- Flying, directions for shooting, 5, 6
- Food, for young pheasants, 400; for adult pheasants and partridges, 404
- Foot-scent, hunting of spaniels by, 137
- Fouling, breech-loaders, free from, 310
- Fox, destructive to game, 408; trapping of the, 436
- Fulminate of mercury, preparation of, 205; the mixture used in ordinary caps, *ib.*
- Fulminate of silver, preparation of, 204, 205; digested with caustic potash, 205
- GADWALL, the, 86
- Gallinule, the, 82
- Game, rearing of, 394 *et seq.*; varieties of, which can be artificially raised (*see* Pheasants, Partridges, &c.) *ib.*; methods of obtaining eggs, 395, 396; hatching, 397-9; pen for young pheasants, 400; diseases of 404, 405; turning out of, 406; rearing of, in a wild state, *ib.*; the various kinds of vermin destructive to, 407 *et seq.* (*see* Vermin); labourers the best preservers of, against poaching, 443; the poachers' methods of taking, 446-8; provisions for dealing in, 459; penalty for killing without a certificate, 461; penalties for trespassing in search of, 463, 464, 465 (*see* Game laws).
- Game certificates, act for repealing the duties on, 475
- Game-keeper, his onerous duties, 387, 388; his honesty, 388; a knowledge of the law necessary, 389; number of keepers required, *ib.*; his gun, *ib.*; his certificate, 394; his duties in destroying vermin, 407.
- Game-keepers, powers of, in manors, 458; regulations respecting their appointment, 458, 459; appointment of in Ireland, 474
- Game licence act, 475
- Game laws, historical notices of the, 449 *et seq.*; the English game laws, 450; Col. Layard's suggestions respecting the, 451; the new game law of 1831 for England and Wales, 452, 467; acts repealed thereby, 452; what shall be deemed game, *ib.*; their prevention of the sale of game out of season, 453; certificated persons may sell game, 459; penalty for killing game without a certificate, or for destroying the eggs of game, 461; penalties for the infringement of, 462, 466; law for permitting the killing of hares without a certificate, 468; old laws not repealed, 469; the Scotch laws relating to hares and trespasses, 470, 471; of Ireland, 473; appointment of gamekeepers, 474; the act of 1860, for repealing the duties on certificates and granting certificates to deal in game, 475
- Game-preserving, guide to, 387 *et seq.*; duties of the gamekeeper and their onerous nature, 387-390 (*see* Gamekeeper); selection of preservers, 390; contracts for taking moors or manors, 393; rearing game, 394 *et seq.* (*see* Game)
- Gapes, inhaler for, 405
- Garganey, the, 86
- Gathering a doubtful bird, 12
- Gauge of the shot-gun, 171

- Gid, the, 50
 Gillies, the deer-stalkers of Scotland, 106, 111
 Gins for trapping vermin, 430; directions for setting upon poles, 431
 Golden-eye, the, 86
 Golden plover, characteristics of the, 39
 Goose, the common wild one, 84; the bean goose, *ib.*; the white-fronted, the
 bernicle, and the Brent goose, 85
 Grebes, their natural habits, 82, 83
 Green plover, characteristics of the, 39
 Greener's bullet, 333
 Grey plover, or grey sandpiper, characteristics of the, 40
 Grinding of shot-gun barrels, 221
 Groove, the ratchet-wheel or feathered-edged, 333
 Grooves of the rifle, their variety almost infinite, 316
 Grouse, varieties of, 14 *et seq.*; the capercaillie or wood grouse, 15, 21; black
 grouse, 16; red grouse, 17; the ptarmigan, 19, 21; breeding of, difficult, 394
 Grouse shooting, 14; varieties of grouse, 14 *et seq.*; best dogs for, 23; gun
 for, 25; dress and accessories for, 25, 27; management of the beat, 27
et seq.; number of dogs required, 29; black game and red grouse, 29, 30;
 retrieving grouse, 30
 Guernsey partridge, 34
 Gun, for grouse shooting, 25; for pigeon shooting, 10 (*see Rifle*); for partridge
 shooting, 44; for snipe shooting, 55; for pheasant coverts, 59; for wood-
 cocks, 71; breaking the dog at pairing time without the, 124; ferrets
 used in aid of the, 152; composition of gun-powder, gun-cotton, and
 other explosive mixtures used with the, 199; of the gamekeeper, 389 (*see*
Guns, Rifles, Shooting, and Shot-gun)
 Gun-barrel proof act of 1855, 224; its provisions, 225, 226
 Gun-case and its contents, 253
 Gun-cotton, composition of, 199, 203; its disadvantages, 203; its use recom-
 mended by Capt. Norton, *ib.*
 Gunnery, elementary principles of, 168 *et seq.*; definition of, as applied to
 sporting purposes in the 19th century, 168 (*see Guns*)
 Gunpowder, on the action of, 178 *et seq.*; effects of its explosion, 178; modes
 of determining the quantity produced from explosion, 179, 180; its action
 on the projectile, 180 *et seq.*; recoil caused by, 187, 189; composition of,
 199 *et seq.*; fine-grained explodes more rapidly, 201; the desiderata re-
 quired in, *ib.*; the leading manufacturers of, 202; Capt. Brown's discovery,
ib.; prices of, 203; best mode of drying it, *ib.*
 Guns, duck and punt ones, 87; classification of, 169; description of, as applied
 to shooting, 170; barrels of, 171; the gauge, *ib.*; spring locks, 173; modes
 of exploding, 174; desiderata in, 175; final boring of, 177; breech-
 loading, 254 *et seq.* (*see Breech-loading guns*); on the choice of, and the
 modes of using them, 301 *et seq.*; weight of, *ib.*; length, pattern, penet-
 ration, and recoil, 302, 306, 307, 309; safety, 303; the "Field" gun, trial
 of, in 1859, *ib.*; tables of the results, 304, 305; targets for, and names of
 the different makers, *ib.*; patterns, 306; advantages and disadvantages
 of breech-loaders and muzzle-loaders, 309
- HALF-BRED terrier, 151
 Hall's cartridges, 246; described, *ib.*
 Handiness in the field of breech-loaders and muzzle-loaders, 309
 Hare shooting, 56, 57
 Hares, the poachers' methods of catching, 448; regulations for killing, 468;
 Scotch law relating to, 470
 Harlequin duck, the, 86

- Harpy**, destructive to game, 416
Harriers, different kinds of, destructive to game, 416-19; their various names, 416, 418
Hatching game eggs, 397 *et seq.*; pen for, 400; kinds of food required for, 400, 401
Hawker's punt guns, 299
Hawk-trap for catching vermin, 431
Heather-bleater, the, 49
Hebrides, deer forests of the, 100
Hedgehog, destructive to game, 412
Hedge-popping, 6
Hedgerow pheasant shooting, 62
Hen-harrier, destructive to game, 418; its various names, *ib.*
Henry's muzzle-loading rifle, 332
Hexagonal ball, 330
Hobby, destructive to game, 420
Hunting, laws respecting, 468
Hurdle for pheasant pen, 403
Hutch-trap for catching vermin, 432

INVERNESS-SHIRE, deer forests of, 100
Irish game-laws, 473; the qualification, 474; gamekeepers, 474; law of trespass, *ib.*
Iron, different kinds of, for forging gun-barrels, 214-19; process of forging it into barrels, 220
Ivy-owl, destructive to game, 424; its natural habits, 425

JACKDAW, destructive to game, 427
Jack-snipe, the, 50
Jacob's four-grooved muzzle-loading rifle, 325
Jaques' sight-guard for rifles, 375
Jay, destructive to game, 428
Jeffries' cartridge-filling machine, 293
Joyce's patent wire cartridges, 246; described, 247
Judcock, the, 50

KENNELS and kennel management, 158
Kestrel, destructive to game, 422; its natural habits, 422, 423
King Charles's cookers, 137
Kite, destructive to game, 413; its mode of taking its prey, and its cunning, 414
Knot, the, 53

LABOURERS, the best preservers of game, 443; the poaching labourer the worst of all poachers, 444
Laminated iron barrels, 217
Lancaster's needle gun, 280-6; advantages and disadvantages of, 286, 290; his method of loading cartridges, 295; the oval spiral rifle claimed by, 324; his breech-loading rifles, 351
Land-retriever, 144; different breeds and crosses, 144, 145
Landrail, characteristics of the, 36
Lapwing, characteristics of the, 41
Law, knowledge of, necessary in a gamekeeper, 389
Layard, Colonel, his suggestions respecting the game laws, 451
Lead, all sporting projectiles made of, either as balls or shot, 207, 208
Leetch's breech-loading rifle, 345, 346

- Lefauchaux's breech-loading gun, 255; the back-handed lever, 257; cartridge and chamber, 258; the barrel, 259; the cartridge-case, 260; the lock, 261; the stock, false breech, and bolt, 262; various modifications of, 263; his breech-loading rifle, 353; cartridges for, *ib.*; modification of his plan, 362
- Lever, back actioned, 257
- Lever of Lancaster's needle gun, 283; of Chateauvillier, 288
- Lice, how to kill, 162
- Licences, act for the regulation of, as regards game and the excise, 475 *et seq.*
- "Line of fire," explanation of the term, 320
- Linen jacket for partridge shooting, 44
- Loading of the percussion gun, 244, 245; cartridges for, 245, 246; rules to be observed for preventing accidents, 251; of breech-loading punt-guns, 299; safety from risk in, 310; facility in, 379
- Lockfast breech-loading gun, 268
- Lock and lock cylinder of Needham's needle gun, 272, 275
- Locks of the shooting guns, 173, 174; principle of, 227; of the ordinary percussion gun, 237; representations of the, 238, 239; plate and bridle, 238; striker and tumbler, 238, 240; mainspring and swivel, 239, 240; variations in the shape of the plate, *ib.*; difference in the price of, 241; cleaning the, 252; of the breech-loading gun, 261; of Lancaster's needle-gun, 285; of Chateauvillier's, 289; of Needham's, 296; of Dean's revolver, 365
- Long-tailed duck, the, 86
- Lords of manors may appoint gamekeepers, &c. 458
- MACKENZIE and Wentworth's breech-loading rifle, 358, 359
- Magpie, destructive to game, 428
- Mainspring of the percussion lock, 239, 240; of Needham's needle-gun, 276
- Mallard, wild, its natural habits, 78
- Mange, dressing for, 163
- Manors, our southern, birds found on, 32 *et seq.* (*see* Birds, Partridge-shooting, &c.); for game-preserve, choice of, in the south, 390; form of contract for taking, 393
- Marine wild-fowl shooting, 88, 92
- Marshes of Great Britain, 53
- Marsh-harrier, destructive to game, 416; its various names, and natural habits, 416, 417
- Martens, destructive to game, 408; best mode of trapping them, 435
- Mercury, fulminate of, 205
- Merlin, destructive to game, 420; its natural habits, 421
- Mock pheasants for deceiving poachers, 447
- Montague's harrier, destructive to game, 419
- Moor-hen, characteristics and natural habits of the, 82
- Moors, nature of the, 21; fatigue of walking the, 22 (*see* Manora)
- Mould shot, different sizes of, 208
- Moulds for casting bullets, 366
- Muzzle-loading guns, 212, 233; advantages and disadvantages of, as compared with breech-loaders, 309; ramrods for, 376; different requisites of the, 379; choice of, 380 (*see* Percussion gun)
- Muzzle-loading sporting rifle, 371 *et seq.* (*see* Sporting rifle.)
- NEEDHAM'S needle-gun, 271-280; its advantages and disadvantages, 279, 280, 290; his breech-loading punt-gun, 300; his breech-loading rifle, 352
- Needle guns, 271 *et seq.*; Needham's needle-gun, 271-280; Lancaster's, 280-6; Chateauvillier's, 287-9

- Needle pea-rifle and cartridge for rook and rabbit shooting, 360
 Newfoundland dog, for wild-fowl shooting, 89
 Nipple, of the ordinary percussion gun, 235; adapting it to the breech, 236
 Norfolk plover, the, 38
 Norfolk spaniel, 136
 Nuthall's muzzle-loading rifle, 325-330
- OPEN shooting, 14
 Oval spiral muzzle-loading rifle, 324
 Owls, different kinds of, destructive to game, 423, 424
- PAIRING time, breaking pointers and setters at, 124; breaking at, without the gun, 124
 Parasites, that infest the shooting dog, how to kill them, 162
 Partridges, varieties of, 32 *et seq.* (*see* Partridge shooting); rearing of, 394; best food for, 404; diseases of, *ib.*; bushing the best protection for, against poachers, 447
 Partridge-shooting, 14, 32; the common partridge, 32; the red-legged partridge, 34; our partridge manors, 42; the partridge land of England, *ib.*; partridge dogs, 43; best gun for, 44; dress and accoutrements for, 44; management of the beat for, *ib.*; modern fashionable mode of, 46; retrieving of partridges, 48
 Patches, use of, 210; for casting bullets, 370; patch cylinder, 372.
 Patterns of guns, 302, 306, 309
 Peewit, characteristics of the, 41
 Pen for young pheasants, 399, 400; hurdle for, 403
 Penalties for infractions of the Game-laws, 462, 466, 471, 473
 Penetration of shot-guns, 302, 307, 309
 Percussion-caps, invention of, 174; preparation of, 206; the manufacturers of, *ib.*; made of black antimony, 207
 Percussion gun, the muzzle-loading, 233 *et seq.*; the barrel and breeching, 233, 234; the nipple, 235; the lock, 237 *et seq.*; the stock and the ramrod, 241; the various parts, 242; weight of the, 243, 244; cartridges for loading, 245, 246; the cleaning, 251; the gun-case and contents, 253; prices of, *ib.*
 "Percussing," its meaning, 231
 Perth, deer forests of, 100
 Pheasant-shooting, 56; coverts for, 58; dogs for, *ib.*; the covert gun, 59; the battue, *ib.*; wild pheasants, 61; hedge-row pheasants, 62
 Pheasants, their habits, 56; hatching and rearing of, 394, 395; methods of obtaining their eggs, 395, 396; hatching, 397 *et seq.*; pen for the young ones, 400; and keeping tame ones, 402; hurdle for, 403; best food for, 404; diseases of, and their cure, 404-6; turning out of, 406; rearing them in a wild state, *ib.*
 Physic of dogs, 161, 163
 Pigeons, directions for shooting at, 13; trap-shooting, 7; laws of, 8, 9; rules and practical directions for, 10; the best kind of pigeon, the "blue rock," 11
 Pistols, revolving, 363-5
 Plate and bridle of the percussion lock, 238; variations in the shape of the plate, 239
 Plover, the different varieties, and their characteristics, 38, 39
 Plug of Chateauvillier's needle-gun, 289
 Plunger and cylinder of the "Field" rifle, 356
 Poachers, and the best modes of counteracting their schemes, 442 *et seq.*; the certificated poacher, 444; the regular poacher and his proceedings, 445; their usual methods of taking the game, 446-8; mock pheasants for

- deceiving them, 447; bushing the best protection for partridges against, *ib.*; the Scotch poachers difficult to counteract, 448
- Poaching labourer, the worst of all poachers, 444
- Pochard, natural characteristics of the, 81
- Pointer and terrier, cross, 145
- Pointers, for grouse-shooting, 23, 24; for partridge shooting, 43; their general use, 113; the old Spanish pointer, *ib.*; the modern English one, 114; the points to be looked at, 114, 115; on the breaking of, 118; preparatory education, 120; breaking them at pairing time without the gun, 124; the points to be taught, *ib.*; management of, after work, 167
- Points in which the shooting dog should be made obedient to the word of command, 121; to be taught the shooting dog,—the range, the point, to back, and to draw, 124-131
- Poison, use of, for the destruction of vermin, and mode of laying it, 441; strychnine the best, *ib.*
- Polecats, destructive to game, 409; trapping of the, 436
- Polygroove rifle, 383
- Pony, for shooting, 156; use of the, 157
- Pouches. (*see* Shot-pouches)
- Powder and powder-flasks for rifles, 210, 211, 377, (*see* Gunpowder)
- Preserves, selection of, 390
- Prices of percussion guns, 253, 254
- Prince's breech-loading rifle, 337, 340
- Projectiles, action of gunpowder on, 180; modes of determining their velocity, 183; plan of measuring the velocity, 185; resistance of the motion of, 187; on the varieties of, and the substances used in aid of them, 207 *et seq.*; all sporting projectiles made of lead, either cast, as in balls, or dropped from a height, as in shot, 207-9
- Proof-marks of shot guns, 226
- Proving of shot guns, according to the "Gun-barrel Proof Act," 224, 225; provisional and definitive proofs, 225, 226; proof-marks, 226
- Provisional proof-marks, 225-7
- Ptarmigan, the, 19, 21
- Punt-guns, management of, 87; employed for marine shooting, 88; the shoulder duck-gun, 299; Col. Hawker's punt-gun, *ib.*; Needham's breech-loading punt-gun, 300
- Purdey's two-grooved muzzle-loading rifle, 321, 322
- Puzzle peg, the, 133
- QUAIL**, characteristics of the, 35
- RABBIT-SHOOTING**, 56, 57, 75, 104; dogs employed for, 77; rifle for, 360
- Rabbiting and rabbit dogs, 150, 151; varieties of terriers, *ib.*
- Rabbits, the poachers' methods of catching, 448
- Rackheath's cartridges for loading, 245
- Ramrods, for muzzle-loading gun, 212; of the muzzle-loading guns, 241, 376
- Range, one of the points to be taught the shooting-dog, 127
- Ratchet-wheel groove, 333
- Rats, destructive to game, 411; trapping of, 437
- Raven, destructive to game, 426
- Rearing of game, 394 *et seq.* (*see* Game)
- Rearing and feeding of ferrets, 152
- Recoil of the gun, causes of the, 187; remarks on the, 189, average force of the, 197; tabular view, 198; amount of which can be borne by the shoulder, 199; chief causes of undue force, *ib.*; absence of, 302, 309; measurement of, 306

- Red Deer, the, 96
 Red Grouse, 17
 Red-grouse shooting, 30
 Red-legged partridge, 32, 34
 Restell's breech-loading rifle, 344, 345
 Rests for target practice, 377; Captain Conolly's rest, 378
 Retrievers and retrieving, both on land and in the water, 143 *et seq.*; the deerhound, 143; the land retriever, 144; water retrievers, 145; teaching to retrieve, 146
 Retrieving, best plan for grouse and partridges, 30, 48; to be taught the spaniel, 137
 Revolver, applicable to sporting purposes, 336 *et seq.*; different requisites of the, 379
 Revolving rifles and pistols, 363; Colt's, *ib.*; Dean's, 364, 365
 Richards' breech-loading rifle, 347-351; its construction, 348; its success at the Wimbledon Meeting, 350; his cartridge, 350, 351
 Rifle, general directions for using the, 1; first lessons in the use of the, 2, 3; taking aim, 3; learning to hit a dead mark, 4; hedge-popping and rook-shooting with the, 6; objects for which it is used, 93 *et seq.*; description of the, 177; for sporting purposes (*see* Sporting rifle)
 Rifles, classification of, 169 (*see* Guns)
 Rifle-shooting, 93 *et seq.*; objects for which the rifle is used, 93; the target, 94; the stag, 96; the roebuck, 98; the deer, 99; the sporting rifle, 102; rooks, 103; the rabbit, 104; deer-stalking, 105, 111; theory of, 311 *et seq.*
 Rifling, method of, 318; machine and driving-wheel for, 318, 319
 Rifling a smooth-bore, velocity diminished by, 312
 Rigby's needle-pea rifle, 360
 Ringtail, destructive to game, 418
 Rod, forged into gun-shot barrels, 220
 Roebuck, the, 98
 Rook-shooting with the shot-gun, and rifle, 6, 103, 360
 Ross-shire, deer-forests of, 99
 Royston crow, destructive to game, 427
 Ruff, the, 53

 SAFETY from accidents, 303; from bursting, 309
 Safety-guard of the stock, 228, 230; the shot-gun, 229, 230
 Sandpiper, the common, 31; the green, 52
 Scaup-duck, the, 86
 Sear, sear-spring, and trigger of Needham's needle-gun, 276
 Sear-spring of the percussion lock, 241
 Scotch game-laws, 470-3; trespass act, 471
 Scotch terrier, 151
 Scooter, the, 86
 Scotland, deer-forests of, 99
 Screw-cam of Needham's needle-gun, 276
 Setters for grouse-shooting, 23, 24; three classes of, English, Irish, and Russian, 115-118; on the breaking of, 118; their preparatory education, 120; breaking them at pairing time without the gun, 124; the points to be taught, *ib.*; management of after work, 167
 "Setting up," its meaning, 231
 Sham-dam for shot-gun barrels, 219; its great inferiority, *ib.*
 Sharp's American breech-loading rifle, 363
 Sheldrake, the, 86
 Shooting, varieties of, 1 *et seq.*; first lessons in, 2; taking aim, 3; flying, 5; rooks, 6; pigeon and sparrow-trap shooting, 7, 8; varieties of, 12, 13;

- attitude in, 12; at pigeons, 13; at sparrows, 14; of grouse, partridges, and snipes, 14 *et seq.*; of pheasants, cocks, and rabbits, 56 *et seq.*; of wild fowl, 73; with the rifle, 93; animals employed by the shooter, 113; breaking of field spaniels for, 135; use of retrievers in, 143; rabbits, 150; on the general management of dogs for, 158; gunnery and guns as applied to, 168 *et seq.*; action of gunpowder, and other explosive compounds, 178; action of the projectile in, 180 *et seq.*; recoil caused by, 187, 189; varieties of projectiles, and the substances used, 207; balls and shot, 207-10; varieties of shot-guns, and the accessories used with them, 212 *et seq.*; the muzzle-loading percussion gun, 233; breech-loading guns, 254; punt-guns, 299; choice of guns, and the modes of trying them, 301; rifle shooting, 311 *et seq.* (*see* Sporting rifle); at various distances, 314; at sporting ranges, 336; selection of preserves for, 390.
- Shooting pony, 156
- Shot for snipe shooting, 55; casting of, 208; different sizes, 208-10; number of contained in one ounce, 209; different manufacturers of, *ib.*; ramming down of, 210; spread of the, 249; most useful sorts of, 250.
- Shot-gun, rook-shooting with the, 6; desiderata in the, 175
- Shot-guns, varieties of, and the accessories used with them, 212 *et seq.*; parts common to them all, 212; the ramrod, *ib.*; the barrel, 213 *et seq.* (*see* Barrels); the breech, 224; proving, 224-6; the lock and the stock, 227; the trigger and guard, 229; safety-guard, 230; percussioning and setting up, 231; browning and case-hardening the muzzle-loading percussion gun, 233 *et seq.* (*see* Gun-shooting and Rifle.)
- Shot-pouches, 210; representation of, 211
- Shoveller, the, 86
- Sight-guard for the rifle, 375
- Sights, plain and telescopic, 376
- Silver, fulminate of, 205
- Skin cartridges, invented by Captain Hayes, 339
- Skye terrier, 151
- Smith's American breech-loading rifle, 353; his cartridge, 354
- Smooth-bore, its advantages, 384
- Snipe, varieties of, 48 *et seq.* (*see* Snipe-shooting); eccentricity of its flight, 54
- Snipe-shooting, 14, 48; varieties of snipe, 48-53; the great or solitary snipe, 48; the common snipe, 49; the Jack snipe, 50; the summer snipe, or common sandpiper, 51, 52; the fens and marshes for, 53; dogs for, *ib.*; dress and accoutrements for, 54; management in, *ib.*; the gun, shot, &c. for, 55
- Solitary snipe, the, 48
- Sore feet, treatment of, 167
- Spaniels, their varieties, 135; field-spaniels divided into springers and cockers, *ib.*; the Clumber, the Sussex, and the Norfolk spaniel, 136; hunting of, by foot-scent, 137; should be taught to retrieve, *ib.*; their preliminary education, 138; entering and breaking, 139
- Sparrow-hawk, destructive to game, 419
- Sparrow-trap shooting, 7; laws of, and practical directions for, 10, 14
- Sporting ranges, shooting at, 336
- Sporting rifle, 103, 311 *et seq.*; definition of the, 311; velocity diminished by rifling a smooth bore, 312; velocity greatest at the moment of leaving the muzzle, 313; results of shooting at various distances, 314; variety in the form of the grooves almost infinite, 316; the barrels, 317; method of rifling, 318; driving-wheel of rifling machine, 319; technical terms, 320; muzzle-loading rifle, 321; Mr. Purdey's two-grooved, 321-323; the ordinary two-grooved, 323; the Enfield, *ib.*; the oval spiral, 324; General Jacob's four-grooved, 325; Major Nuthall's and Mr. Boucher's rifles, 325-

330; the Whitworth rifle, 330, 331; Henry's, 332; single and double barrels, 335; breech-loading rifles and revolvers, applicable to sporting purposes, 336; Prince's rifle, 337-340; Terry and Callisher's 340-4; Beestell's, 344; Leetch's, 345; Westley Richards' 347-351; Lancaster's, 351; Needham's, 352; Lefauchaux's, 353; Bastin's, *ib.*; Gilbert Smith's, 353, 354; the "Field" rifle, and its advantages, 355-8; Wilson's rifle, 358; Mackenzie and Wentworth's, 358, 359; Rigby's, 360-2; Sharpe's, 363; revolvers, 363-5; accessories bullets, cartridges, powder, &c., 366-378; choice of the, 379 *et seq.*; different requisites of the muzzle-loader, breech-loader, and revolver, 379, 380; final choice of, 380; polygroove rifle, 383; for deer-shooting, 385 (*see* Rifle-shooting)

Spring locks, the first ones made, 173

Springer, a field spaniel used for hunting pheasants and hares, 135

Stag, the, 96; its natural characteristics, 96, 97

Steel-traps for catching vermin, 430; unbaited trap, 440

Stoats, destructive to game, 410; trapping of, 436

Stock of the shot-gun, 227; with the false breech, *ib.*; with safety guard, 228; of the percussion gun, 241; of the breech-loading gun, 262

Stone curlew, the, 38

Striker of the percussion lock, 238, 240

Strychnine, the best poison for destroying vermin, 411

Stub-Damascus, erroneously called "steel," 217

Stub-twist barrels, 216

Summer snipe, the, 51

——— teal, the, 86

Sussex spaniel, the, 136

Sutherland, deer-forests of, 99

Swan, wild, varieties of the, 83; its natural habits, 83, 84

Sledge-machine for casting bullets, 370

Swivel of the percussion lock, 239

TAKING aim, 3

Target practice, rests for, 377, 378

Target-shooting, 94

Teal, the, its characteristics and natural habits, 80

Technical terms in rifle-shooting, 319

Telescope for deer-stalking, 101

Telescope-sights for rifles, 376, 377

Terrier for rabbiting and rabbit-shooting, 77, 150; the old English terrier, *ib.*; the Scotch, the Skye, the Dandie Dimmont, and the half-bred, 151; for killing vermin, 440

——— and beagle cross, 145

Terry and Callisher's breech-loading gun, 291

Terry's breech-loading rifle, 340-4; his description, 341

Ticks, how to kill, 162

"Trajectory," the, 320

Trap-shooting, 7; of pigeons, and the laws of, 8

Trapping of vermin, and traps, 429 *et seq.*; the gin or steel trap, 430; the hawk trap, 431; the box trap, 432, 433; weasel trap, 435; best modes of trapping, *ib.*; of cats and martens, *ib.*; of the fox, polecats, stoats, and weasels, 436; of rats, 437; of birds, 437-9; of egg destroyers, 439; the unbaited steel trap, 440

Trespass, old law of still in force, 469

Trespassing in search of game, penalties for, 463-5, 472; in Scotland, 471; in Ireland, 474

Trigger of Needham's needle-gun, 276

- Trigger of Dean's revolver, 365
 Trigger and guard of the shot-gun, 229
 Trulock and Harris's cartridge-loading tool, 292
 Tufted duck, the, 86
 Tumbler of the percussion lock, 238, 240
 Twopenny and threepenny skelp iron used for very inferior guns, 218, 219
- VELOCITY** of the rifle ball, 312; greatest at the moment of leaving the muzzle, 313; Mr. Boucher's theory of, 313-16
- Vermín destructive to game, the various modes of destroying them, 407 *et seq.*** ; the cat, 407; the marten, 408; the fox and the polecat, 409; the stoat, 410; the weasel and the rat, 411; the hedgehog, 412; the eagle and the kite, 413; the falcon, 415; the buzzard, 416; the harriers, 416-19; the sparrow-hawk, 419; the hobby and the merlin, 420; the kestrel, 422; the owls, 423, 424; the raven and the crow, 426; the hooded crow and the jackdaw, 427; the magpie and the jay, 428; traps for, and trapping them, 429-40 (*see* Trapping)
- paratitcal, various applications for the destruction of, 162
- Vermín terrier, its usefulness, 440**
- WADDING, use of, 210**
- Windage, explanation of the term, 320**
- Watchers, necessity for, 444**
- Water-rail, the, 82**
- Water retrievers, 145, 148**
- Water spaniel, for wild-fowl shooting, 89; the old English, 145; the Irish, *ib.***
- Weasels, destructive to game, 411**
- traps for, and trapping of, 435, 436
- Weight of a double-barrelled shot-gun, 301**
- Whimbrel, the, 86**
- White-fronted goose, 85**
- Whitworth's muzzle-loading rifle, 330; the bore and ball, 331**
- Widgeon, its characteristics and natural habits, 79**
- Wild fowl, varieties of, 78-86; the wild mallard, *ib.*; the widgeon, 79, the teal, 80; the pochard and pin-tailed duck, 81; the moor-hen, water-rail, and grebes, 82; the coot and wild swan, 83**
- Wild-fowl shooting, 78 *et seq.*; terms used in, 78; duck and punt guns used in, 87; marine shooting, 88; best dog for, 89; flapper shooting, 89; winter shooting in inland waters, 90; use of decoy ducks, and marine shooting, 92**
- Wild geese, and their varieties, 84, 85; varieties of wild duck, 86**
- Wild-pheasant shooting, 61**
- Wilson's breech-loading rifle, 358**
- Wire-twist barrels, 216**
- Wood grouse, 15**
- Woodcocks, 62; their haunts, and natural habits, 64 *et seq.*, 68; finding and killing of, 71 *et seq.***
- Woodcock shooting, 62 *et seq.*; dogs employed in, 70**
- Worms, remedies for, 164, 165; causes of their presence in dogs, 164**
- YELLOW plover, characteristics of the, 39**

