

THE CUPOLA FURNACE.

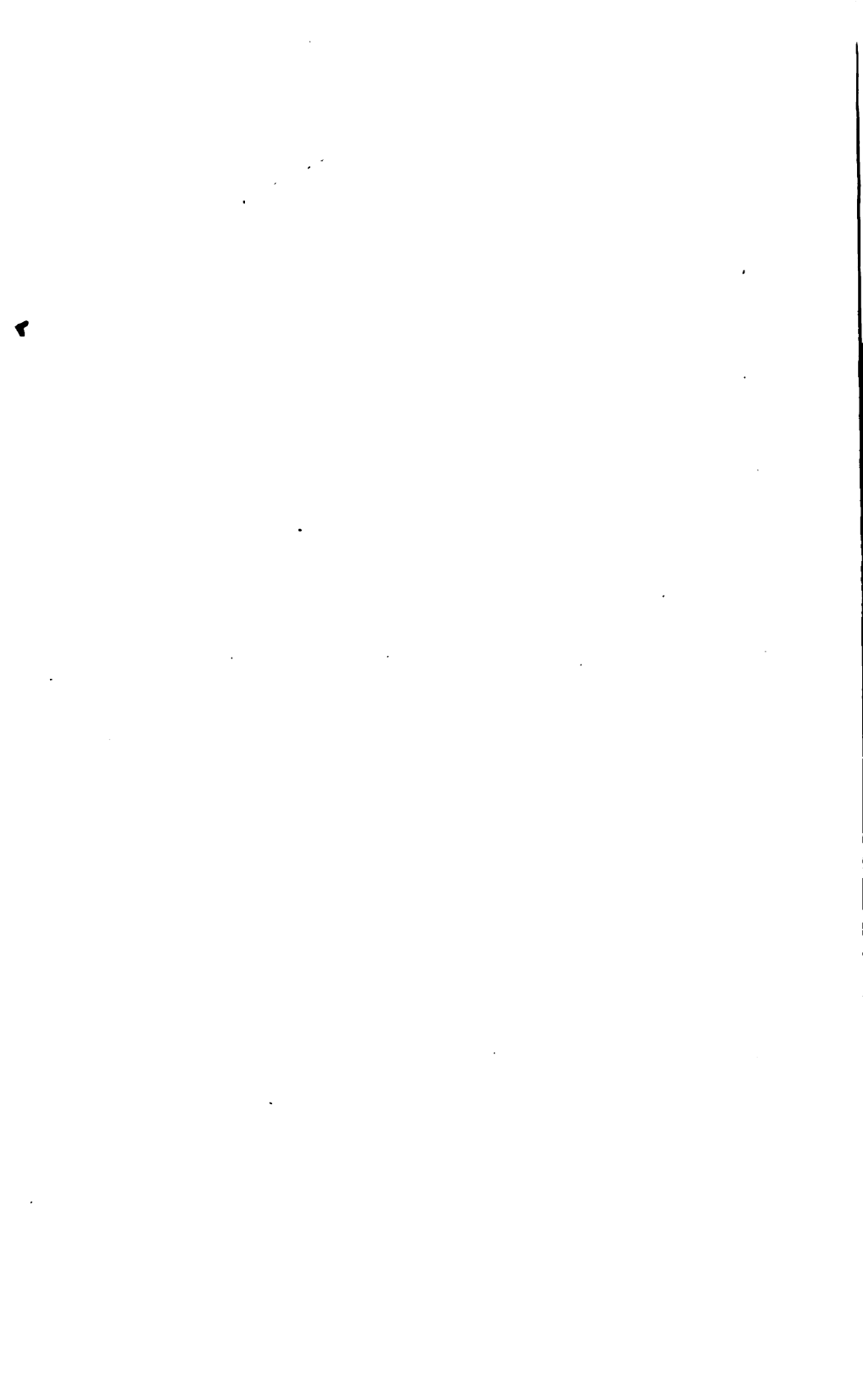

THE CUPOLA FURNACE

A PRACTICAL TREATISE ON THE

CONSTRUCTION AND MANAGEMENT

OF

FOUNDRY CUPOLAS:

COMPRISING

IMPROVEMENTS IN CUPOLAS AND METHODS OF THEIR CONSTRUCTION AND MANAGEMENT; TUYERES; CUPOLA FUELS; FOUNDRY IRONS; MELTING AND MIXING FOUNDRY IRONS; DIFFERENT STYLES OF CUPOLAS; SPARK-CATCHING DEVICES; BLAST-PIPES AND BLAST; BLOWERS; CHEMISTRY OF FOUNDRY IRONS; ETC., ETC.

BY

EDWARD KIRK,

PRACTICAL MOULDER AND MELTER, CONSULTING EXPERT IN MELTING.

Author of "The Founding of Metals," and of Numerous Papers on Cupola Practice.

ILLUSTRATED BY SEVENTY-THREE ENGRAVINGS.

A NEW, THOROUGHLY REVISED, AND ENLARGED EDITION.

PHILADELPHIA :

HENRY CAREY BAIRD & CO.,

INDUSTRIAL PUBLISHERS, BOOKSELLERS AND IMPORTERS,
810 WALNUT STREET.

LONDON :

E. & F. N. SPON, LTD.,

125 STRAND.

1903.

East Engle:
Library

TS

231

.K59c

1903

COPYRIGHT, 1903,
BY
EDWARD KIRK.

PRINTED BY THE
WICKERSHAM PRINTING COMPANY,
53 and 55 North Queen Street,
LANCASTER, PA., U. S. A.

PREFACE TO THE SECOND EDITION.

THE first edition of THE CUPOLA FURNACE having become entirely exhausted, and the demand continuing unabated, and many and urgent requests having come from foundrymen for additional information in this important department of industry, are the inducements which have led to the preparation of this new, revised and enlarged issue of the book.

The scope and usefulness of the work have been much extended by leaving out that which was considered either obsolete or of minor importance, and replacing it by entirely new and up-to-date matter, by which means it is believed that full justice has been done to the subject in all its branches and details. Of this new matter it may be stated that there are no less than 200 pages, including chapters on Improvements in Cupolas, Cupola Fuels, Foundry Irons, and the Chemistry of Foundry Irons.

It is thought that a careful study of these pages can hardly fail to arouse in the founder a realization of the far-reaching importance of an intelligent system of cupola practice, and that only by and through such a system can he obtain, at a minimum cost, an iron always possessing the qualities demanded for the work in hand, for casting.

In conclusion, it only needs to be added, that as is the custom of the publishers, in all cases, they have provided the work with a copious table of contents as well as a very full index, which will render reference to any subject in it, at once prompt, easy and satisfactory.

EDWARD KIRK.

PHILADELPHIA, *January 15, 1903.*

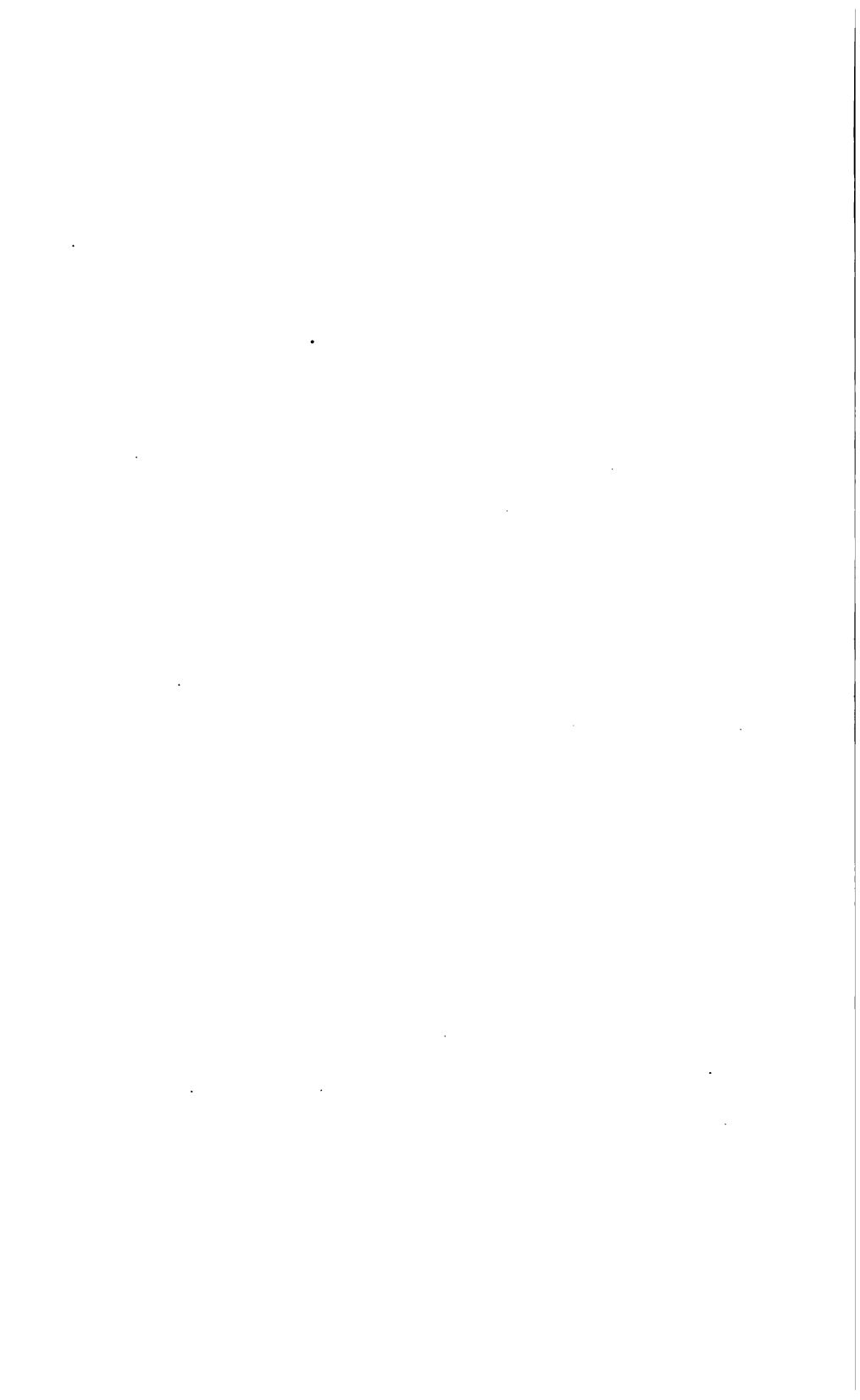

CONTENTS.

CHAPTER I.

THE CUPOLA FURNACE.

PAGE

Advantages of the cupola furnace for foundry work; Quantity of fuel required for melting irons in various kinds of furnaces; Attempts to decrease the amount of fuel consumed in the cupola by utilizing the waste heat	1
Description of the cupola furnace; Forms of cupolas; Sizes of cupolas; Foundation of a large cupola	2
Advantage of iron supports over brick work; Height of the bottom of the cupola; Pit beneath the cupola	3
Bottom plate; Bottom doors; Support of the doors; Various devices for holding the doors in place; Construction of the casings	4
Stack casing; Construction of the stack; Tuyere holes	5
Location of the charging door and its construction; Lining of the casing and materials used for it	6
The scaffold and its location; Size of the scaffold	7

CHAPTER II.

IMPROVEMENTS IN CUPOLAS.

Type of the first cupola furnaces used in this country, and mode of constructing them; Cupolas in the foundry of Chas. Reeder & Sons, Baltimore, Md.	8
Construction of these cupolas	9
Objection to the draw-front cupola	10
First use of the drop-bottom; General mode of building cupolas	11
Supply of blast; Location of tuyeres	12
Cause of slow melting of old-fashioned cupolas; Heights of cupolas; Boiler-plate casings for both cupola and stack	13
Increase in the size of tuyeres; Lowering of the tuyeres to from 4 to 10 inches above the bottom; Introduction of the Mackenzie cupola	14
Abandonment of the old theory of driving blast to the center of the cupola by force of the blower and small tuyeres; Introduction of cast iron tuyere boxes; Objectionable features of the Mackenzie cupola	15

	PAGE
Introduction of the Truesdale cupola; The Lawrence cupola	16
The Pevie cupola; The Dougherty tuyere	17
Introduction of the Colliau plain round cupola, and its complete failure.	18
Application of the system of tapping slag to cupolas; Change in the form of cupola supports, bottom doors, air chambers; Previous use of the double row of tuyeres	19
Advantage of the double row of tuyeres	20
Return to the plain round cupola of forty years ago	21

CHAPTER III.

CONSTRUCTING A CUPOLA.

Proper location of a cupola; The scaffold	22
Conveyance of coal or coke to the scaffold; Cupola foundation and its construction	23
Prevention of uneven settling and breaking of the bottom; Brick walls for the support of a cupola; Best supports for a cupola	24
Height of cupola bottom; Provision for the removal of the dump; Bottom doors	25
Devices for raising the bottom doors	26
Casing; Material for the casing or shell of the modern cupola and stack; Strain upon the casing	27
Contraction of the stack; Prevention of sparks; What constitutes the height of a cupola; Utilization of the waste heat	28
Table giving the approximate height and sizes of doors for cupolas of different diameters; Charging door; Air chamber.	29
Construction of the air chamber when placed inside the casing, and when placed upon the outside of the shell; Objection to the round or overhead air chamber	30
Admission of blast to the air chamber; Location and arrangement of the air chamber when the tuyers are placed high; Tap hole	31
Arrangement when two tap holes are required; The spout and its construction	32
Tapping slag; Location of the slag-hole	33
Tuyeres; Number of tuyeres for small cupolas; Size of combined tuyere area; Tuyere boxes or casings	34
Height at which tuyeres are placed in cupolas; Objection to high tuyeres.	35
Two or more rows of tuyeres; Arrangement of a large number of tuyeres; Area of the rows; Increase in the melting capacity with two or three rows of tuyeres	36
Lining; Materials for lining the casing; Grouting or mortar for laying up a lining; Manner of laying the brick	37
Thickness of cupola linings; Stack lining	38
Arrangement of brackets; Preference by many of angle iron to brackets; Mode of putting in angle irons	39

Reduction of the lining by burning out; Settling of the lining; Mode of reducing the size and weight of the bottom doors and preventing the casing from rusting off at the bottom	40
Prevention of the absorption of moisture into the lining; Illustration of the triangular-shaped tuyere in position in the lining; Form of bottom plates; Fire-proof scaffolds	41
Exposure of the scaffold and its supports to fire; Devices to make scaffolds fire-proof	42
Novel plan of construction of a scaffold and cupola house in Detroit, Mich.; Best and safest scaffolds	43
Cupola scaffolds in the foundries of Gould & Eberhardt, Newark, N. J., and of The Straight Line Engine Company, Syracuse, N. Y.	44

CHAPTER IV.

CUPOLA TUYERES.

Mode of supplying the cupola furnace with air; Admission of the air through tuyeres or tuyere holes; Former and present melting capacity of a cupola; Epidemics of tuyere invention	45
The round tuyere; Arrangement of round tuyeres in the old-fashioned cast-iron stove cupola	46
Oval tuyere; Expanded tuyere	47
Doherty tuyere	48
Sheet blast tuyere; Mackenzie tuyere	49
Blakeney tuyere	50
Horizontal and vertical slot tuyere	51
Reversed T-tuyere; Truesdale reducing tuyere	52
Lawrence reducing tuyere	53
Triangular tuyere; Results in melting with this tuyere obtained by the Magee Furnace Co., Boston, Mass.	54
Water tuyere	55
Colliau tuyere; Whiting tuyere	56
Chesney tuyere; The double tuyere; Mode of placing the tuyeres in Ireland's cupola; Claims for the double tuyere	57
Consumption of fuel in a double tuyere cupola; Three rows of tuyeres; Cupola constructed by Abendroth Bros., Port Chester, N. Y.	58
Object in placing tuyeres in a cupola; Production of heat by consuming the escaping gases from the combustion of fuel	59
Greiner tuyere; Adjustable tuyeres	60
Cupola of the Pennsylvania Diamond Drill and Manufacturing Co., Birdsboro, Penna.; Bottom tuyere	61
Mode of covering the mouth of a bottom tuyere	62
Bottom tuyere patented by B. H. Hibler; Thomas D. West on the bottom tuyere	63
Size of tuyeres	64

	PAGE
Size of the combined tuyere area of a cupola; Height of tuyere; Great difference of opinion on this subject	65
Experiments with tuyeres at various distances above the sand bottom; Experiment to soften hard iron by bringing the molten metal in contact with charcoal; Reason given in favor of high tuyeres	66
Tuyeres in stove foundry cupolas	67
Location of tuyeres in smaller cupolas; Tuyeres in machine and jobbing foundry cupolas, and in cupolas for heavy work	68
Number of tuyeres; Objection to the use of only one tuyere	69
Two tuyeres sufficient for the largest cupola in use; Arrangement of a double row of tuyeres; Shape of tuyeres	70
Tuyeres to improve the quality of iron; Tuyere boxes	71

CHAPTER V.

CUPOLA MANAGEMENT.

Necessity of learning the peculiarities in the working of a cupola; A cupola cannot be run by any given rule or set of rules; Drying the lining	73
Drying a backing or filling between the casing and lining; Putting up the doors; Devices for raising the doors into place	74
Support of double doors; Sizes of props to support the bottom	75
Ring attachment to the prop; Superstition of older melters regarding the prop; Dropping the doors; Modes of releasing the prop	76
Sand bottom; Sand employed for this purpose; Objection to clay sands and other sands; Sand which makes the very best kind of bottom	77
Wetting the bottom sand; Bringing the sand into the cupola	78
Cause of leakage in the sand bottom	79
Boiling of iron due to a wet bottom; Pitch or slope of the bottom	80
Effect of a high pitch; Change in the action of the iron at the spout by the pitch of the bottom; How the bottom should be made	81
Slope of the bottom in cupolas with two tap holes; Spout; Spout lining material	82
Effect of the use of too much clay or too much sand in the lining; Mode of making up the spout lining	83
Building up the sides of the lining; Place of the greatest strain upon the spout lining	84
Proper shape of the spout lining; Cause of pools of iron forming in the spout; Removal of slag from the spout	85
Front; Material used for putting in the front; Mode of putting in the front	86
Effect of making the front material too wet; Troubles due to poor front material	87
Sizes of tap holes; Locating the tap holes	88
Slag hole	89

CONTENTS.

xi

	PAGE
Slag hole front; Chilling of slag in the tap hole	90
Lighting up; Mode of placing the wood and shavings in the cupola; Putting in the bed fuel	91
Effect of carelessness in arranging the wood and lighting up; The bed; The melting point in a cupola; The melting zone and determination of its exact location; Necessity of discovering the melting point in order to do good melting	92
To find the melting point	93
Cause of trouble in melting after a cupola has been newly lined; Fuel required for a bed in cupolas of different diameters	94
Charging; Old way of loading or putting the fuel and iron into a cupola; Modern way of stocking a cupola; Correct theory of melting iron in a cupola	95
Practical working of a cupola upon this theory; Effect of too heavy charges of iron and of too heavy charges of fuel; Variation in the weight of the first charge of iron	96
Variations in the per cent. of iron to fuel; Placing the charges	97
Mode of placing the pieces of pig or other iron; Distribution of the charge of fuel; First step in mixing irons when melted in a cupola	98
Placing the pig iron when melting with remelt scrap	99
Charging when melting old scrap and pig; Charging additional iron	100
Bad charging as a cause of poor melting; Improper and proper charging of a cupola; Charging flux; On what the quantity of flux depends	101
Blast; The old and the modern ways of giving blast to the cupola; Blast phenomena	102
Melting; When melting begins in a cupola; Difference in opinion as to the time for charging the iron before the blast is put on	103
Best time for putting on the blast; Chilling and hardening of the first iron; Running off a heat without stopping in; Mode of reducing the size of the tap hole	104
No advantage in holding molten iron in a cupola to keep it hot; Proper management of hand-ladle work; Indication of how the cupola is melting by the flow of iron from the tap hole	105
Poking the tuyeres	106
Fuel; Amount of fuel required in theory and practice; Necessity of keeping an accurate account of the amount of iron melted	107
Chief object of melting iron in a cupola; The old story of "not enough blast;" Necessity of an even volume of blast	108
Tapping bars; Shapes and sizes of tapping bars	109
Steel bar for cutting away the bod before tapping; Bod sticks; Combina- tion stick; Objection to this stick	110
Number of bod sticks for each cupola; Bod material; Importance of the material of which the bod is composed; Loams for bods	111
Mixture for a good bod; Bod for small cupolas; Qualities of a good bod; Tapping and stopping in	112

	PAGE
Mode of making the bod; How to make the tap	113
Mode of stopping in; Difficulties in stopping in; Devices to assist in stopping in; The skill of the melter seen at the tap-hole	114
Uneven melting is the fault of the melter; Dumping	115
Removal of the small props; Bridging over in small cupolas above the tuyeres, and mode of removing the bridge; Various methods of handling the dump	116
Removing the dump, and various devices for this purpose	117
Breaking up the dump and picking it over; Different ways of recovering the iron from the dump; Chipping out	118
Theory of some melters to prevent iron from running into the tuyeres; Objection to this theory; Cupola picks	119
Daubing; Materials used	120
Soaking fire clay; Amount of sand required for mixing with the clay; No advantage in using a poor, cheap daubing	121
Putting on the daubing; Shaping the lining; Object of applying daubing to a lining; Mode of making new linings	122
Chipping off cinder and slag that adhere to the lining over the tuyeres; No necessity for filling in the lining at the melting zone and making it perfectly straight; Objections to sudden offsets or projections	123
Thickness of the daubing; Sectional view of a cupola, illustrating effect of excessive daubing	124
Shaping the lining of the boshed cupola; Special directions required for shaping and keeping up the lining of patent and odd-shaped cupolas	126
Relining and repairing; Thickness of the lining; Location of the greatest wear on the lining; Destruction of the lining at and below the tuyeres; Length of time a cupola lining will last; Burning away of the lining	127
Thickness of lining required to protect the casing; Repairing the lining at the melting zone	128
Repairing a lining with split brick; Mode of making a split brick	129

CHAPTER VI.

EXPERIMENTS IN MELTING.

Various opinions formerly held by foundrymen as to the point in a cupola at which the melting of iron actually took place; Different ways of charging or loading a cupola	130
Experiments to learn definitely at what point iron is really melted in a cupola; Construction of an experimental cupola	131
Results of the first experiment	132
Arrangement of the bars of iron for the next experiment	133
What was learned from the experiment; Arrangement of the bars and cupola for the next heat	134
High pressure of blast may be almost wholly due to the size of the	

	PAGE
tuyeres; Arrangement of the bars for the next heat, and the result of this experiment	185
Arrangement of the cupola for the next heat and result of the experiment	186
Fuel used in the experiment; Reasons why iron is not melted in a cupola by the blast and flame of the fuel; Melting zone in a cupola	187
Fuel under the tuyeres	188
Low tuyeres; Result of an experiment with low tuyeres	189
Melting zone; What determines the location of a melting zone in a cupola; Lowering and raising the melting zone	140
Change in the location and depth of the melting zone	141
Experiments to learn the depth of the melting zone in practical melting.	142
Charges used in the experiments	143
Charges with which the most even melting was done in these experiments; Necessity of passing the blast through a certain amount of heated fuel before a melting zone was formed in a cupola	144
Cause of iron melted high in a cupola being made dull	145
Development of the melting zone above the tuyeres; Experiments with a cupola with the tuyeres placed near the top; Failure of the plan	146
Melting with coal; Softening hard iron; Experiments in softening iron by passing it in a molten state through charcoal in its descent from the melting zone to the bottom of the cupola	147
Time for charging; Difference of opinion among foundrymen as to the proper time for charging; Experiments to ascertain the proper time for charging and putting on the blast after charging	149
Devices for raising the bottom doors	150
Device for raising heavy doors	151

CHAPTER VII.

EXAMPLES OF BAD MELTING.

Necessity of giving causes of poor melting; Trouble with the cupolas at the stove foundry of Perry & Co., Sing Sing, N. Y.	152
Cause for the trouble	153
Sectional views of linings out of shape	155
Remedy for the troubles	159
Bad melting at a West Troy stove works; Visit to the foundry of Daniel E. Paris & Co., West Troy, N. Y.; Inspection of the foundry with a view of locating the trouble	161
Trouble due to the use of too much fuel	162
Experiment of running the cupola with less fuel; Objection of the melter to the experiment	163
Result of the experiment	164
Heats with a still further reduction of fuel	165
Cause of bad melting in this foundry	166

	PAGE
Warming up a cupola; Visit to the plant of the Providence Locomotive Works, Providence, R. I.; Trouble with the cupola	167
Cause of the poor melting due to the bed being burned too much	168
Remedy of the trouble; Bad melting caused by wood and coal; Cause of poor melting in one of the leading novelty foundries in Philadelphia.	169
Poor melting in a Cincinnati cupola; Sectional elevation showing the condition of the cupola	170
Uneven burning of the bed; Reason for the necessity of dumping a cupola at the foundry of Perry & Co.	172

CHAPTER VIII.

CUPOLA FUELS.

Coke the best cupola fuel; Gas and liquid fuels; Reason why these fuels cannot be used in a cupola	173
Experiments of melting iron in a cupola with gas and liquid fuels	174
Failure to produce a hot fluid iron	175
Charcoal fuel; Superiority of iron produced with this fuel	176
Mode of charging when melting with charcoal; Weight of charges of fuel and iron	177
Anthracite coal as a cupola fuel; Pennsylvania hard coal fields	178
Difference in coal from the various mines in the same region; Opening of the first mine in the Pennsylvania districts	179
Charging and melting with coal	180
Heat melted with Old Mine Lehigh coal; Considerable variation in the per cent. of coal consumed in melting	181
Per cent. of coal consumed in melting for one year at different foundries; Size of coal used in melting	182
Best results obtained in melting with coal	183
Mixture of coal and coke; Manner of charging and melting with mixed fuels	184
Heat melted in a 54-inch Whiting cupola with Schuylkill coal and Connellsville coke	185
Cupola coke; First coke made in ovens; First shipment of coke	186
Practice of foundrymen making their own coke	187
Various grades of coke; Cause of failures in making coke; Superiority of the coal of the Connellsville region for the manufacture of coke	188
Use of gas-house coke for small heats; Requirements for the manufacture of a good foundry coke	189
Early practice in melting with coke	190
Mode of judging the melting qualities of a coke; Number of pounds of iron melted to pounds of fuel; Variation in the quality in the early days of coke	191
Cause of the variations in the quality of coke; Best cupola coke; 72-hour coke	192

	PAGE
Manner in which iron is melted in a cupola furnace	193
Mistake by melters who do not understand the space theory of a cupola; Theory of melting which should be followed by every founder melting with coke	194
Remedy in melting when coke is poor; Rule of charging coke and iron.	195
Weight of coke required for a bed; Measurement and weight the best guides for bed and charges	196
Watching the melting for indications of necessary changes	197
Difference of opinion as to the per cent. of coke to iron; Reports of melting with Connellsville coke and what is indicated by them	198
Bituminous coal as a cupola fuel; Experience in melting with this fuel.	199
No deterioration in the quality of the iron by the coal	200
Selection of coal	201

CHAPTER IX.

FOUNDRY IRONS.

Blast furnaces and their construction	202
Open and closed furnaces; Designation of irons by the fuels used in smelting the ores	203
Charcoal irons; Mode of casting charcoal irons; Cold-blast charcoal iron.	204
Uses of cold-blast iron	205
Production by chemical analysis of an iron from coke or anthracite irons having the characteristics of a cold-blast charcoal iron; Hot-blast charcoal iron and its uses	206
Best known and most famous brands of this iron; Coke iron and its characteristics	207
Mode of grading coke iron; Manner of casting coke iron; Indication of the strength of the iron	208
Anthracite iron; Location of the furnaces producing this iron	209
Silver gray iron; High silicon iron	210
Qualities imparted to iron by silicon in large proportions; Proportion of silicon that may be used in a foundry iron; Distribution of the silicon throughout the iron	211
Percentage of silicon in pig irons for foundry work	212
Scotch pig and its use	213
Explanation of the term "kish;" American-Scotch pig; Best brands of this iron	214
Foundry pig; Pig irons; Casting of pig irons	215
Variation in the quality of the cast; Sandless pig and mode of casting it.	216
Principal objection to this iron; Inconvenience in handling the pig	217

CHAPTER X.

MELTING AND MIXING FOUNDRY IRONS.

Object in melting iron in a cupola; Necessity of properly melting the iron; What should be taken into consideration when deciding upon placing a new cupola in a foundry	218
Proper way to melt iron; Importance of mixing of various grades of iron to be cast into one iron; How irons should be mixed	219
The only way in which an even grade of iron can be drawn from a cupola; Melt iron hot; What is meant by hot iron in the foundry sense; How to obtain such iron	220
Materials that resist almost any degree of heat in molten iron; Wrong impression that iron when melted very fast and hot is burned in melting	221
Composition of cast iron; Metalloids in cast iron	222
Constitution of dirt and dross which rise to the surface when iron is permitted to cool in a ladle; Reasons why iron should be melted hot and poured hot	223
Mixing irons; Erroneous impression that different grades of iron mix by merely being brought in contact with each other in a molten state; Uselessness of placing tuyeres high in a cupola for the purpose of collecting iron in a cupola to mix it before tapping	224
How a mixture of the different grades of iron is effected	225
What should be aimed at in charging the different grades of iron in a cupola; How better results are obtained by mixing irons	226
Manner of thoroughly mixing irons; Handling of ladles	227
Cast iron in founding; Metalloids in combination with iron; Explanation of the term "metalloids"	228
Removal of metalloids from cast iron; The puddling furnace; How iron is melted in a cupola	229
How iron should be melted to retain the metalloids and to evenly distribute them throughout the iron	230
Mode of preventing the separation of metalloids; Shot iron and hard spots in castings	231
Collection of shot iron from the dump; Breaking up and cleansing the dump and other refuse	232
Restoration of gangway-shot, vents, etc.	233
Modes of preventing shot iron from hardening other irons; Melting of an entire heat of shot iron	234
Recovering iron from foundry dumps; Unsatisfactory results from attempting to recover iron from the dump	235
Device for melting shot iron in iron pots; Melting shot in wooden boxes	236
Enclosing of shot iron in pigs; Grades of iron which may be obtained from shot iron when remelted; Experiments in melting shot iron	237
How the shot was melted in making these experiments	238

	PAGE
Quality of iron produced from rusted shot; Phenomena observed when melting shot with other irons	239
Mode of recovering scrap; Melting shot iron with a ferro silicon iron	240
Oxidized iron; Burned iron in founding; Fracture of burned cast iron; Mistake made in judging this iron by the fracture	241
Tricks of trade of junk dealers; Quality of iron produced by burned cast iron	242
Change in the nature or quality of an iron; Mode of preventing hard spots; Wrought iron scrap	243
Effect of small pieces of wrought iron, Prevention of hard spots; Melting cast iron turnings and borings	244
Prevention of oxidation of this iron in melting	245
Best plan for melting this iron in a cupola; Uncertainty of results in melting this iron	246
Melting of this iron in ladles; Use of this iron for sidewalks, etc.; Melting wrought iron and steel turnings and borings	247
Tests made in melting this scrap	248

CHAPTER XI.

FLUXING OF IRON IN CUPOLAS.

Definition of a flux; Substances used as fluxes; Purpose of the use of limestone in the production of pig iron	249
On what the making of a brittle cinder in a cupola by the use of limestone depends; Limestone in large quantities	250
Variation in the quantity of limestone required to produce a fluid slag; Weight of slag drawn from a cupola	251
Constituents of the slag; Effect of flux upon iron	252
The action of fluxes on lining	253
How to slag a cupola; Cause of trouble in slagging; General method of charging the limestone; The slag hole	254
Slag in the bottom of a cupola; Importance of the time for drawing the slag; Does it pay to slag a cupola? Estimate of the cost of slagging	255
Shells; Use of oyster, clam and other shells; Cause of the crackling noise of shells when the heat first strikes them; Marble spalls	256
Experiments with mineral and chemical materials with the view of making a cheap malleable iron; Reason why iron is often ruined as a foundry iron by improper melting and fluxing	257
Effect of silicon on iron; Per cent. of silicon an iron may contain; Use at the present time of a large amount of high silicon cheap Southern iron	258
Heavy breakage due to the use of high silicon iron; Effect of carbon upon cast iron; Removal of free carbon from iron	259
Fluor spar and its use as a flux	260
Cleaning iron by boiling; Poling molten iron	261

CHAPTER XII.

WHAT A CUPOLA WILL MELT.

Chief use of the cupola furnace; Employment of the cupola furnace for other purposes than melting iron; Quantity of cast iron that can be melted in a cupola	263
Number of hours a cupola may be run; Size and weight of a piece of cast iron that can be melted in a cupola; Charging large pieces of iron at the foundry of the Pratt & Whitney Co., Hartford, Conn ; Melting of cannon and other heavy government scrap at the Lobdell Car Wheel Co., Wilmington, Del.; Melting large pieces of iron	264
What should be done when the iron comes dull	265
Melting tin plate scrap in a cupola; Recovery of tin deposited upon the iron; Quality of the molten metal from this scrap	266
Experiments in melting this scrap	267
Melting scrap sheet iron and galvanized sheet iron scrap; Melting tin-plate scrap	268
Construction of a cupola expressly for melting tin-plate scrap	269
Amount of profit in melting this scrap	270

CHAPTER XIII.

ART IN MELTING.

The art of melting iron in a cupola but little understood by many foundrymen and foundry foremen; Troubles experienced in melting	271
No chance work in nature or in art; Necessity of understanding the construction and mode of operation of a cupola to do good melting	272
Location and arrangement of the tuyeres; Preparation of the cupola for a heat; Lighting up	273
Melting iron in a cupola a simple process; Things to be learned and practiced; Necessity of a close study of all the materials used in melting	274
What should be the aim of every moulder; Advisability of the foreman of a foundry being the melter; Duties of the melter	275
Taking off the blast during a heat	276
Banking a cupola; Mr. Knoeppel, Foundry Superintendent, Buffalo Forge Co., Buffalo, N. Y., on this subject	277
Give the melter a chance; Respect due to the practical and scientific melter; Unfortunate position of a poor melter	279
Interference with a good melter frequently the cause of poor melting; Necessity of furnishing proper tools for chipping out, and making up the cupola	280
What should be the aim of every melter; Interest of every foundryman to keep his melter posted	281

CONTENTS.

xix

CHAPTER XIV.

PAGE

THE CUPOLA ACCOUNTS.

Value of cupola accounts; Manner of keeping the accounts	282
Cupola report of Abendroth Bros., Port Chester, N. Y.	283
Cupola report of Byram & Co., Iron Works, Detroit, Mich.	284
Daily report of Foundry Department, Lebanon Stove Works	285
Melting sheet of Syracuse Stove Works	286
Report of castings in — Shop	287
Cupola slate for charging and cupola report	288
Blanks for reports and records, and mode of making them out; Report on a slate; Correctness essential to the value of a cupola account; Cost of melting	289
Unreliability of melting accounts as generally kept; Objection to measuring fuel in baskets; Result of a supposed accurate account of the melting in a foundry in New Jersey	290
Proper method of figuring the cost of melting per ton	291

CHAPTER XV.

SCALES AND THEIR USE.

Necessity of an accurate weighing scale upon the scaffold; Size of scale required; What the melting of iron, in a cupola, when reduced to an art, consists in	293
Division of the fuel and iron into charges; The theory of melting not understood by many foundrymen; Incorrect methods of calculating the charges of iron and fuel	294
Mistaken economy in using old worn-out scales	295

CHAPTER XVI.

EXPLOSION OF MOLTEN IRON.

Conditions under which molten iron is explosive; Explosions caused by a wet spout or a wet bod	296
Cause of sparks; Various causes of the explosion of molten iron; Explosion due to thrusting a piece of cold, wet or rusted iron into molten iron	297
Explosion of molten iron when poured into a damp or rusted chill-mould or a wet sand mould; Accident in the foundry of Wm. McGilvery & Co., Sharon, Pa.	298
Explosion of molten iron when poured into mud or brought in contact with wet rusted scrap; Accident in the foundry of James Marsh, Lewisburg, Pa.; Accident at the foundry of North Bros., Philadelphia, Pa.	299

	PAGE
Explosions at the foundry of the Skinner Engine Co., Erie, Pa., and at the Buffalo School Furniture Co., Buffalo, N. Y.	300
Prevention of explosions	301

CHAPTER XVII.

DIFFERENT STYLES OF CUPOLAS.

Old style of cupola in general use throughout this country many years ago, described and illustrated	302
Practice of casting with the use of the old-style cupola	304
The reservoir cupola, described and illustrated	305
Stationary bottom cupola; Old-style English cupola, described and illustrated	307
Expanding cupola, described and illustrated	308
Ireland's cupola, described and illustrated	310
Ireland's center blast cupola, described and illustrated	312
Voisin's cupola, described and illustrated	314
Woodward's steam jet cupola, described and illustrated	316
Objection to this style of cupola; Tank or reservoir cupola, described and illustrated	320
Production of soft iron by putting a quantity of charcoal on the sand bottom; Use of tanks in England	322
Mackenzie cupola, described and illustrated	323
Management of the Mackenzie cupola	325
Dr. Otto Gmelin's cupola, described and illustrated	326
Pevie cupola, described and illustrated; Object of Mr. Pevie in constructing a cupola upon his plan	329
Stewart's cupola, described and illustrated; Rapid melting of this cupola	331
The Greiner patent economical cupola, described and illustrated	333
Steam jet cupolas	334
Experiments in melting in a cupola with steam with and without blast.	335
Conclusions drawn from observations in melting with wet and superheated steam	336
Colliau cupola; Standard Colliau cupola furnace, described and illustrated	337
The Newten cupola, described and illustrated	340
Claims of the manufacturers for this cupola	342
Paxson Colliau cupola, described and illustrated	344
Indestructible wire screen charging door of this cupola	346
The Whiting cupola, described and illustrated	347
Latest type of the Whiting patent cupola; Jumbo cupola, described and illustrated	349
Charge table for the Jumbo cupola	350

	PAGE
The Crandall improved cupola with Johnson patent center blast tuyere, described and illustrated	353
Mode of applying the air to this cupola	354
Blakeney cupola, described and illustrated	355
Cupola on wheels; Paxson truck and track cupola, described and illustrated	357
The adjustable tuyere; What is new in the cupola and furnace line; Moor's patent cupola breast and runner, and mica schist lining, described and illustrated	359
Mica schist lining; Other native lining materials	361
Common red brick lining	362

CHAPTER XVIII.

HOT BLAST CUPOLAS.

A pair of cupolas constructed at Albany, N. Y., by the firm of Jagger, Treadwell & Perry, described and illustrated	363
Cupola constructed at the stove foundry of Ransom & Co., Albany, N. Y.	365
Heating the blast for a cupola; Waste heat from a cupola, and devices for utilizing it	366
Height of a cupola for utilizing all the heat	367

CHAPTER XIX.

SPARK CATCHING DEVICES FOR CUPOLAS.

Spark catcher in old-style cupolas, described and illustrated; Modern spark arrester, described and illustrated	368
Return flue cupola spark catcher, designed by John O'Keefe, described and illustrated	371
Other spark catching devices	373
The best spark catching device	374

CHAPTER XX.

BLAST PIPES AND BLAST.

Blast pipes; Importance of the construction and arrangement of blast pipes; Underground blast pipes; Objections to this arrangement	375
Materials used in the construction of blast pipes; Galvanized iron pipes; Joints; Table prepared by the Buffalo Forge Co., Buffalo, N. Y., as a guide for increasing the diameter of pipes in proportion to the length.	376
Diameter of blast pipes; Friction in pipes; Frequent cause of a blower being condemned as insufficient; Connection of blast pipes with cupolas	377
Table showing the necessary increase in diameter for the different lengths	378

	PAGE
Connecting blast pipes direct with tuyeres; Combined area of the branch pipes; Table of diameter and area of pipes	379
Perfect connection of air chambers, described and illustrated; Poor arrangement of pipes, described and illustrated	380
Mode of connecting a belt air-chamber with the tuyeres, described and illustrated; Best way of connecting blast pipes with cupola tuyeres	382
Blower placed near cupola	383
Poor melting often caused by long blast pipes; Perfect manner of connecting the main pipe with an air chamber; Placing a blower; Convenient way of placing a blower near a cupola	394
Blast gates; Advantage of the employment of the blast gate	385
Explosions in blast pipes; Prevention of such explosions; Blast gauges; Variety of gauges	387
Indication of the pressure of blast; What an air-gauge to be of any value in melting must indicate	388
Blast in melting; Means for supplying the required amount of air to the cupola; Machines for supplying the blast	389
Relative merits of a positive and non-positive blast	390
Amount of air required for combustion of the fuel in melting a ton of iron; Theory of melting in the old cupolas with small tuyeres	391
Points to be remembered in placing tuyeres in a cupola; Best tuyere for large cupolas	392
Size of the largest cupolas in which air can be forced to the center from side tuyeres; Cupolas of the Carnegie Steel Works, Homestead, Pa.; Experiments with a center blast tuyere	393
Claims for the center blast	394

CHAPTER XXI.

BLOWERS.

Types of blowers	395
The Green patented positive pressure blower; Connersville cycloidal blower	396
Sectional view of this blower; Advantages of this arrangement	397
Horizontal blower; Numbers, capacities, etc., of the cycloidal blowers	400
Vertical blower and engine on same bed-plate	401
Blower and electric motor	402
Root's rotary pressure blowers, described and illustrated	403
Root's horizontal pressure blower	404
Garden City positive blast blower, described and illustrated	405
Claims made for this blower; Fan blowers; The Sturtevant blowers; Steel pressure blowers, described and illustrated; Wheel and boxes of this blower	407
Steel pressure blowers on adjustable bed with combined upright engine.	408
Electric steel pressure blowers	409

	PAGE
Buffalo steel pressure blower, described and illustrated	411
Blower on adjustable bed, and on bed combined with countershaft; Latest construction form of the Buffalo steel pressure blower	414
Buffalo blower for cupola furnaces in iron foundries	415
Table of speeds and capacities as applied to cupolas	416

CHAPTER XXII.

CUPOLA STRAPS.

Brief paragraphs illustrating important principles; Terms used in different sections of the country to indicate the melting of iron in a cupola	417
Best practical results for melting for general foundry work	421
Remarks by Mr. C. A. Treat; Difficulty experienced by a foundryman in obtaining reliable cupola reports for publication	422

CHAPTER XXIII.

CHEMISTRY OF FOUNDRY IRONS.

First attempt by the Crane Iron Co. to make chemistry available in blast furnace practice	424
Great value of analyses when accurate; Foundry chemistry; Mr. Alexander E. Outerbridge, Jr., the first to make a success of the chemistry of foundry irons	425
Short history of "Chemistry in the Foundry" by A. E. Outerbridge, Jr.	426
Investigation of foundry iron; The chemist and the foundry	428
Causes of the failure of the application of chemistry to foundry practice.	429
Excuses of the chemists; Excuse-making melters; Qualifications of a foundry chemist	430
What has to be determined by a foundryman before he can produce first-class castings	431
Necessity of the chemist possessing practical knowledge	432
Controversy with Thos. D. West on this subject	434
Endorsement of the author's view by a number of gentlemen; The matter brought to the attention of the Foundrymen's Association; Paper by the author on "The Training of Foundry Chemists" read before the Association at their meeting at Chicago, in June, 1900	435
Preparation of a student to become a chemist in foundry iron	436
Duties of a chemist under the present system of foundry chemistry as advocated by some of our leading founders	437
What the founder wants to hold his own against steel	438
Technical training for foundry managers; Report of the committee	439
Chemists for present needs	440
Grading and mixing iron by analysis; Basis for the selection and mixing of iron by analysis for castings	441
Rule in mixing iron by grade analysis	442

	PAGE
Chemistry and cupola practice; Destruction of the value of chemistry by bad cupola practice	443
Requirements for a practical melter; Pyrometers	444
On what the theory of melting is based; Space or zone in which iron may be melted; Proper height for a bed	445
Amount of iron to be placed upon the fuel; Most important point in melting; Good plan for determining the height of the bed	446
Point to be guarded against in melting; Duties of a foundry chemist	447
Indications of fracture in foundry iron; How the chemist can utilize this knowledge which is necessary to his success	448
Avoidance of chances of bad results; What the fracture of a freshly-broken pig indicates	449
Indications of the characteristics of cast iron; Fracture of very hard iron; Fractures of number two and number one iron and of silver grey iron	450
Crystal of a high-silicon iron; Value of fracture indications; Color of the iron in castings	451
What the fracture in cracks or breaks from shrinkage indicates; Crystal of iron broken when in a semi-fluid state; Importance of the indications of this fracture	452
Dirty iron shown up by fracture	453
Index	455

CHAPTER I

THE CUPOLA FURNACE.

THE cupola furnace has many advantages over any other kind of furnace for foundry work.

It melts iron with less fuel and more cheaply than any other furnace, and can be run intermittently without any great damage from expansion and contraction in heating and cooling. Large or small quantities of iron may be melted in the same furnace with very little difference in the per cent. of fuel consumed, and the furnace can readily be put in and out of blast. Consequently in all cases where the strength of the metal is not of primary importance, the cupola is to be preferred for foundry work.

In the reverberatory furnace from ten to twenty cwt. of fuel is required to melt one ton of iron.

In the pot furnace one ton of coke is consumed in melting a ton of cast iron, and two and a half tons in melting a ton of steel.

In the blast furnace twenty to twenty-five cwt. of coke is consumed in the production of a ton of pig iron.

In the cupola furnace a ton of iron is melted with from 172 to 224 lbs. of coke.

It will thus be seen that in the cupola furnace we have the minimum consumption of fuel in melting a ton of iron, although the amount consumed is still three or four times that theoretically required to do the work.

Many attempts have been made to decrease even this small amount of fuel consumed in the cupola, by utilizing the waste heat passing off from the top for heating the blast. But the

cupola being only intermittently at work has rendered all such attempts futile.

The cupola furnace is a vertical furnace consisting of a hollow casing or shell, lined with fire-brick or other refractory material, resting vertically upon a cast iron bottom plate, having an opening in the centre equal to the inside diameter of the lining and corresponding in shape to the shape of the furnace. This opening is closed with iron doors covered with sand when the furnace is in blast. Two or more openings are provided near the bottom of the furnace for the admission of air by draught or forced blast. A small opening, on a level with the bottom plate, is arranged for drawing off the molten metal from the furnace. An opening, known as the charging door, is made in the side of the casing at the top of the furnace for feeding it with fuel and iron, and a stack or chimney is constructed above the charging door for carrying off the escaping smoke, heat and gases.

Cupolas have been constructed cylindrical, elliptical, square and oblong in shape, and they have been encased in stone, brick, cast iron and wrought iron casings. From one to a hundred or more tuyeres have been placed in a cupola, and the stationary and drop bottoms have been used. At the present time cupolas are constructed almost entirely in a cylindrical or elliptical form, and the casing is made of wrought iron or steel boiler plate. The stack casing is made of the same material and is extended up to a sufficient height to give draught for lighting up, and to carry off the escaping heat and gases. The drop bottom has been almost universally adopted, at least in this country.

Cupolas are constructed of various sizes, to suit the requirements of the foundry they are to supply with molten metal. Those of large size are, when charged with iron and fuel, of immense weight, and require very solid foundations to support them. The foundation is generally made of solid stone work up to the level of the foundry floor; upon this is placed brick work laid in cement, or cast iron columns or posts, for the sup-

port of the iron bottom and cupola. In all cases where the cupola is set at sufficient height from the floor to admit of the use of the iron supports they are to be preferred to brick work, as they admit of more freedom in removing the dump and repairing the lining. The columns or posts are placed at a sufficient distance apart to permit the drop doors to swing free between them. This arrangement removes the liability to breaking the doors by striking the cupola supports in falling, and admits of their being put back out of the way when removing the dump.

The height of the bottom of the cupola above the moulding floor depends upon the size of the ladles to be filled, and varies from fourteen inches to five feet. If placed too high for the sized ladle used, considerable iron is lost by sparks and drops separating from the stream in falling a long distance, and the stream is more difficult to catch in the ladles. For hand ladle work it is better to place the cupola a little higher than fourteen inches, and rest the ladle upon a hollow oblong pedestal eight or ten inches high, and open at both ends, than to set it upon the floor. The ladle can then be moved back or forward to catch the stream, and iron spilled in changing ladles falls inside the pedestal, and is prevented from flying when it strikes the hard floor, and is collected in one mass inside the pedestal. This arrangement reduces the liability of burning the men about the feet and renders it easier to lift the full ladle.

If a cupola is set very low, it is then necessary to make an excavation or pit beneath it to permit of the removal of the dump, and repairing of the lining. This pit is made as wide as it conveniently can be, and of a length equal to two or three times the diameter of the cupola. The distance from the bottom plate to the bottom of the pit should not be less than three feet. The bottom of the pit is lined with a hard quality of fire-brick set on edge, and the floor sloped from the edges to the centre, and from the end under the cupola outward, so that any molten iron falling with the dump will flow from under the cupola, and thus facilitate its removal. In the centre of the

pit under the cupola a block of stone or a heavy block of iron is securely placed, upon which to rest the prop for the support of the iron bottom doors.

The bottom plate is made of cast iron, and must be of sufficient thickness and properly flanged or ribbed to prevent breaking. If broken when in place, it can not be removed, and it is then almost impossible to securely bolt it so as to hold it in place. The plate must be firmly placed upon the iron supports or brick work, so that no uneven strain will be put upon it by the weight of the cupola and stack.

The bottom doors are made in one piece or in two or more sections. For large cupolas they are generally made in two or four sections to facilitate raising them into place. Bottom doors are made of cast or wrought iron. Those made of cast iron are, when in place, the stiffest and firmest. Those made of wrought iron are the lightest and easiest to handle, but are also more liable to be warped by heat in the dump, and to spring when in place. The door, or doors, whether made of cast or wrought iron, have wide flanges to overlap the bottom plate and each other when in place, to prevent the sand, when dry, running out through cracks and making holes in the sand bottom. The doors are supported in place by a stout iron or wooden prop; and when the doors are light, or sprung, one or more additional props are put in for safety. Numerous bolts and latches have been devised for holding the doors in place, but they have all been abandoned in favor of the prop, which is the safest. Sliding doors, or plates, have been arranged upon rollers to slide into place under the cupola from the sides, and be withdrawn by a ratchet or windlass to dump the cupola. They admit of easy manipulation; but in case of leakage of molten iron through the sand bottom, they are sometimes burnt fast to the bottom plate and cannot be withdrawn, and for this reason the sliding door is seldom used.

The casings are made of cast or wrought iron plate. When made of cast iron they are cast in staves, which are put in place on the iron bottom and bound together by wrought iron bands;

these bands being shrunk on. Or they are cast in cylindrical sections, which are placed one on top of another, and bolted together by the flanges. This kind of casing generally cracks from expansion and shrinkage in a short time, and is the poorest kind of casing. With the cast iron casing a brick stack, constructed upon a cast iron plate supported by four iron columns, is generally used. The wrought iron casing is more generally employed at the present time than that of cast iron. It is made of boiler plate, securely riveted together with one or two rows of rivets; but one row of rivets, and those three inches apart, is generally found to be sufficient, as the strain upon the casing, when properly lined, is not very great.

The stack casing is generally made of the same material as that of the cupola, and is a continuation of the cupola casing; the two generally being made in one piece.

The stack is made the same size as the cupola, or is contracted or enlarged according to the requirements or fancy of the foundryman. A contracted stack gives a good draught, but throws out a great many sparks at the top. An enlarged stack gives a poor draught, unless it is very high, but throws out very few sparks at the top. As sparks are very objectionable in some localities, and not in others, different sized stacks are used. When surrounded by high buildings or hills, the stack must be made of sufficient height to give the necessary draught for lighting up in all kinds of weather, and they vary in height from a few feet above the foundry roof to twenty or thirty feet. Bands of angle iron are sometimes riveted to the inside of the cupola and stack casing to support the lining, and admit of sections being taken out and replaced without removing the entire lining.

The casing and lining are perforated with two or more tuyere holes near the bottom, for the admission of air by draught or forced blast. These tuyeres, when supplied with a forced blast, are connected with the blower by branch pipes to each tuyere, or are supplied from an air chamber riveted to the cupola casing either on the outside or inside. The air chamber

is made three or four times the area of the blast pipe, and is supplied from the blast pipe connecting it with the blower. An opening is made through the casing and lining, just above the bottom plate, for drawing the molten iron from the cupola, and a short spout is provided for running it into the ladles. Another small opening is sometimes made, just under the lower level of the tuyeres, for tapping or drawing off the slag from the cupola. This opening is never used except when a large amount of iron is melted, and the cupola is kept in blast for a number of hours.

An opening for feeding the furnace, known as the charging door, is placed in the cupola at a height varying from six to twenty feet above the bottom plate, according to the diameter of the cupola. This opening is sometimes provided with a cast iron frame or casing on the inside to protect the lining around the door when putting in the fuel and iron. A door frame is placed upon the outside, upon which are cast lugs for a swinging door, or grooves for a sliding door. The door for closing the charging aperture may consist of a cast or wrought iron frame filled with fire-brick, or be made of boiler plate with a deep flange all around for holding fire-brick or other refractory material. The sliding door consists of an iron frame filled in with fire-brick, and is hung by the top, and moved up and down with a lever or balance weights. This door is moved up and down in grooves cast upon the door frames, which grooves frequently get warped by the heat, and hold the door fast. The hinge or swing door, with plenty of room for expansion and shrinkage, is the door generally used.

The casing is lined from the bottom plate to the top of the stack with a refractory material. A soft refractory fire-brick, laid up with a grout composed of fire-clay and sand, is used for lining in localities where such material can be obtained. In localities where fire-brick can not be procured, soapstone from quarries or the bottoms of small creeks, is laid up with a refractory clay. Some grades of sandstone or other refractory substances are also employed for lining. Native refractory

materials are seldom homogeneous, and those which have been ground and moulded, or pressed into blocks, make the best linings. The thickness of the lining varies in large and small cupolas. Those in the large cupolas are from six to nine inches, and in small cupolas from four to six inches.

The cupola charging aperture being placed at too great a height from the floor to admit of the cupola being charged or loaded from the floor, a scaffold or platform is erected from which to charge it. The scaffold is generally placed in the rear of the cupola, so as to be out of the way when removing the molten iron in crane ladles. But for hand ladle work it is placed at any point most convenient for getting up the stock, and the charging aperture placed in the cupola at any point most convenient for charging. For very large cupolas the scaffold is frequently constructed to extend all around the cupola, and a charging aperture is placed in the cupola on each side, so that it may be more rapidly charged. The scaffold is constructed of wood or iron frame work, or is supported by a brick wall. The floor is placed level with the bottom of the charging aperture, or is placed from one or two feet below it. The scaffold should be made large enough to place a weighing scale in front of the charging door, to hold iron and fuel for several heats, and have plenty of room for handling the stock when stocking the scaffold and charging the cupola. Nine-tenths of the scaffolds are too small for the work to be done on them, and the cupola men work to a great disadvantage when handling the stock. Much of the bad melting done in foundries can be traced directly to the lack of room on the scaffold for properly charging the cupola.

CHAPTER II.

IMPROVEMENTS IN CUPOLAS.

FROM the best information obtainable, it appears that the first cupola furnaces used in foundries in this country were of the type of the stationary bottom draw front cupola. These were constructed upon a solid stone or brick foundation from three to four feet high or upon a hollow foundation with a cast iron plate on top, upon which a cupola bottom of fire-brick or other refractory material was placed.

The cupola casings were generally made of cast iron, with the front opening of a sufficient size to admit of the refuse from melting being drawn from the cupola through the front with an iron hook or rake.

The lining was arched over the front and the opening closed with an iron plate or apron, which was put in place when the lining and bottom had been repaired and made ready for a heat and securely fastened with hooks or other devices. To protect the apron, a temporary lining was put in of loam or other material that could be readily removed while hot after the heat was melted.

When the cupola was large the apron was put in place and the temporary lining was put in before the fire was lighted, and in small ones a wall of coke was built up in the opening, and the loam or other material rammed into the front after the fire was burned up, and the apron placed over it. A small opening or front was placed in the apron for the tap hole.

This style of cupola was the only one used in this country for many years, but it has now generally been replaced by more modern cupolas, and probably the only ones in existence at the present time are those in the foundry of Chas. Reeder &

Sons, Baltimore, Md. These works were established in 1813 for the manufacture of marine and stationary engines, and some of the largest and most powerful marine and stationary engines constructed in early days were cast at this foundry.

To melt iron for these castings, three draw-front cupolas were constructed upon the latest improved pattern of the times; the exact date at which they were built is not known, but it must have been many years ago, for the old foreman in 1874 informed me they were used in melting the iron for castings of marine engines placed in well-known vessels, that had long been out of existence at that time. The cupolas at the time of my last visit to the works, four or five years ago, were the only ones in the foundry, and they are probably still in use, having held their own against all the changes in fashion, until they became the leaders of fashion, for the draw front has again come in use to a considerable extent during the past few years for very small cupolas. These cupolas, three in number, were placed in a row close together upon a cast iron plate supported by a brick foundation three feet high.

Upon this plate eight cast-iron columns ten feet high were placed, for the support of the stack plate upon which rested the cupola stack. The casings of the cupolas and stack were made of boiler plate, the stack was placed directly over the center cupola with side wings extending over the others on either side, so that one stack served for the three cupolas, which were of different sizes. The smallest one was straight and 20 inches in diameter inside the lining. The other two were tapering from bottom to top, one with a diameter inside lining of 42 inches at tuyeres, 36 inches at top, and the other 48 inches at tuyeres and 40 inches at top.

The tuyeres were square and placed 16 inches above bottom. The larger cupolas had four tuyeres and the small one two. The cupola casings were all of the same height, measuring ten feet between bottom and top plate, but the charging door 24 inches high was placed in each cupola below the top plate, which reduced their height to $7\frac{1}{2}$ or 8 feet.

The cupola scaffold was very small, having scarcely sufficient room for stock for the small cupola. This appears to have been the general way of constructing scaffolds in early days, the practice being to only place stock upon the scaffold as it was required for charging, one man placing it in the cupolas as fast as one or more men threw it upon the scaffold from the stage or platform upon which fuel and iron were thrown in passing it up from the yard to the scaffold. There do not appear to have been any cupola runways or elevators in "our grandfathers' days." One of these cupolas, I was informed, was changed to a drop bottom about the time the drop bottom first came into use, but after the loss of a number of heats, from the support of the bottom giving way or leakage through the sand bottom, it was changed back to a stationary bottom, which was considered safer than the drop.

These cupolas did good work in a number of heats I saw melted in them; in fact, they melted equally as well as any of the more modern cupolas of the same diameter and height, of which there were a great many in use at the time referred to.

But the refuse from melting was not so easily removed as from the more modern cupolas. When the apron was removed and the front broken away, the refuse under the tuyeres was readily drawn out, but after this was removed cold air was admitted, which chilled the slag and cinder over the tuyeres, rendering it tough and difficult of removal, and when the cupola was slightly bridged and the refuse did not drop freely, it was almost impossible to remove it. This difficulty occurred so frequently that a long bar was kept on the scaffold for poking the refuse down and getting a hole through, that it might cool off by the next morning.

This is the great objection to the draw-front cupola, which is overcome to a considerable extent by the drop-bottom, which gives way the instant the support is removed and permits everything to drop out when the cupola is not bridged, before it has time to become chilled and tough.

Melters who have never melted in a large stationary bottom

cupola have little idea of what a great boon this was to melters, in the early days, when the tapping of slag from cupolas was not thought of, and it was a common thing to work one or more hours to get a hole through after each heat.

The drop bottom is said to be an American invention and to have been first used in the New England States, but there appears to have been no record of the date at which it was first used, and the oldest foundrymen I have met have not been able to give the date at which it was first introduced.

But so far as I have been able to learn, it has been in use at least fifty years, and perhaps longer, but it was not adopted by all founders when it was first introduced, and many of the stationary bottom cupolas of the old pattern were in use at a much later date, and may still be in use in some of the old foundries like the one before referred to.

With the introduction of the drop bottom cupola there does not appear to have been any other change made in the construction of cupolas. They were generally built upon a brick or stone foundation, with square cast-iron bottom plates, upon the corners of which were placed four columns for the support of another plate upon which was constructed a square stack of common red brick.

The stacks were generally made of a much larger area than the cupolas, that the red brick of which they were constructed might not be burned out and also to prevent sparks or hot cinders being thrown out at the top of the stack. The charging door was generally placed in the stack just above the plate.

Cupola casings were generally made of cast iron and were cast in staves the length or height of the cupola and from four to six inches wide. These staves rested upon the bottom plate and projected up through an opening in the stack plate several inches, or came even with the top of it, and were held together by wrought-iron bands placed a foot or more apart. When boiler plate was obtainable and it was desired to have something fine, casings were made of this material, but the cast-iron stove casings were more common. Small cupolas were gener-

ally made straight and large ones tapering, with the larger end down to facilitate dumping, and their height was from six to eight feet, eight feet being considered a very high cupola.

Blast was supplied through two tuyeres, one placed on either side of the cupolas, and opposite each other, so the blast from each met in the center. When only light work was to be cast they were placed twelve to eighteen inches above the bottom; for heavy work, three sets of tuyeres, one above the other, were put in. They were generally placed twelve, eighteen and twenty-four inches above the bottom. These tuyeres were designed for melting iron for a heavy casting, and when such a piece was to be cast, blast was first put in through the lower ones until the cupola was filled with molten iron to this point. They were then closed with clay and the next set opened, and blast put in until molten iron appeared, when they were closed and the next set opened. To admit of blast being adjusted to the tuyeres of different heights, a tuyere pipe or nozzle of tin or copper was provided and attached to the blast pipe by a leather tube, one end of which was slipped over the blast pipe and the other over the end of the nozzle and securely tied with a leather thong or lace.

A hole was placed in the bend of the nozzle or elbow and closed with a wooden plug for watching the filling up of the cupola with molten iron, and also for poking the tuyeres when they became black.

To admit of the blast being adjusted to the different height of tuyeres when the cupola was in blast, the iron and fuel were not placed in charges, but were mixed by putting in a shovel or two of fuel and a hundredweight or two of iron. This was the common practice of filling the cupola.

This plan of melting for heavy castings did not prove very satisfactory, and later on, in cupolas designed for heavy work, but one set of tuyeres was put in, and these located 24 inches above the bottom: these gave better results than the adjustable tuyeres.

Tuyeres were mostly made very small for the purpose of

putting in the blast with great force, and driving it to the center of the cupola, and were generally made from 3 to 5 inches in diameter, according to the diameter of the cupola. Two of these small tuyeres were considered ample for a small cupola and four for a large one.

These old-fashioned cupolas, in many of which I have melted iron, generally melted very slow. This was due to the tuyere area being entirely too small to supply a sufficient volume of blast and to the cupolas being too low to utilize all the heat of the fuel for heating the iron and preparing it for melting, before settling into the melting zone.

With a cupola only seven feet high, tuyeres 24 inches above the bottom, and top of bed 18 to 20 inches above tuyeres, only 3 to $3\frac{1}{2}$ feet was left for fuel and iron above the bed. It is obvious to almost any founder nowadays, that this was not sufficient space in which to utilize all the heat of the fuel; but this was not the case some years ago, and when I published my first work on foundry practice in 1877, in which I placed a table for heights of cupolas, ranging from 6 to 15 feet, according to diameter of cupolas. This table was ridiculed by the majority of foundrymen, and a 15-foot cupola was declared by many to be impracticable; but the heights given in this table have all been reached and in many cases passed, and the tendency at the present time is to go to the other extreme and overreach the height at which the heat that can be utilized is sufficient to pay for the extra expense of cupola, lining, elevating stock, etc.

There are a few of these old-fashioned brick stack cupolas still in use. There is at least one in Philadelphia, Pa., and two or three could probably be located in Brooklyn, N. Y., and a few in other places, but they have generally given place to the more modern cupolas.

There does not appear to have been any improvement made in cupolas for many years after the adoption of the drop bottom, and they were all constructed with stave casings, brick stacks, etc. The next advancement was the use of boiler-plate casings for both cupola and stack, and construction of cupola

and stack in one piece, doing away with the cast-iron staves, columns, stack plates and brick stacks.

Following this came the abandonment of the adjustable tuyere, nozzle, leather tube, etc., the enlargement of tuyeres, use of various shaped tuyeres, attachment of blast pipes to cupolas, introduction of tuyere boxes, air chambers, etc.; any and all of which were a great improvement over the tuyere nozzle and leather tube, which frequently permitted as great an amount of blast to escape as passed into the cupola. About this time the taper was also abandoned and cupolas of all sizes made of the same diameter from bottom to top.

With the increase in size of tuyeres, and more perfect connection of blast pipes with cupolas, it became apparent from the amount of heat at the charging door that cupolas were too low, and their height was increased from time to time, until heat no longer appeared at the charging door sufficient to burn the hand when the cupola was filled with stock and in full blast.

The next improvement was the lowering of the tuyeres from 12, 18 and 24 inches above the bottom to from 4 to 10 inches above the bottom, and in many of the large cupolas they were placed so low that the sand bottom came up to the bottom of the tuyeres at back of cupola.

These changes were all effected in the common straight cupola, and brought it to such perfection as a melter of iron many years ago that it is very doubtful if any improvement has been effected in cupolas since that time.

Before these improvements were made cupolas melted very slow, and it was the practice to put on the blast just after the noon hour and melt all afternoon. From four to five hours were commonly required to melt any ordinary heat.

Molders generally stopped molding when the blast was put on, and a great deal of valuable time was lost waiting for iron. To prevent this loss of time, Mr. Mackenzie, a practical molder and founder of Newark, N. J., conceived the idea of melting a heat in two hours, and designed the Mackenzie cupola, which, when first introduced, was known as the two-hour cupola.

This cupola, I believe, was the first cupola patented in this country, and it presented a number of new features in cupola construction.

The old theory of driving blasts to the center of the cupola by force of the blower and the small tuyeres was entirely abandoned, and the theory of supplying a sufficient volume of blast to fill the cupola adopted. Cast iron tuyere boxes were bolted to the castings for the attachment of blast pipes, and blast was delivered to the cupola from an inside belt air chamber and continuous tuyere. The air chamber which was formed by an apron riveted at the top to the cupola shell was entirely open at the bottom, giving unlimited space for escape of blast into the cupola.

This was a complete change from the old theory of putting blast into a cupola with great force, and revolutionized the theory of melting. This cupola gave excellent results, and was adopted by all the leading foundrymen of the time, and many of them are still in use, and continue to give good results in melting when properly managed.

But the cupola has its objectionable features, the greatest of which is its tendency to bridge and bung up when not properly managed. This tendency to bridge is due to a large extent to the cupola being boshed by the inside air chamber, and the blast being supplied to it just at the point of the lower angle of the bosh. The blast passes up over the bosh before it becomes heated, causing a chilling of cinder and slag at this point, and the building out of the lining with a very hard substance that is difficult to remove, and careless or incompetent melters frequently permit the lining to grow at this point until the melting capacity of the cupola is reduced one-half, and the smaller ones frequently bridge before they are in blast more than an hour when the lining is permitted to get out of shape.

Much better results might have been obtained from this cupola had the inventor furnished, to be hung up near the cupola for the guidance of the melter, a framed diagram or blueprint, showing the proper shape for lining of the bosh and

melting zone when the lining was new and as it burned away ; but such a diagram was never furnished, and I have frequently seen melters running these cupolas who did not have the least idea of the shape the lining should be put in when repairing it for a heat, having never seen one when newly lined or in shape.

The next patent cupola to come into prominence was the Truesdale cupola, designed by Mr. Truesdale, foreman of the Resor Stove Works, Cincinnati, Ohio. This cupola was supplied with blast from an inside belt air chamber through the Truesdale reducing tuyere, which consisted of a series of openings through the lining placed one above the other only an inch or two apart, the diameter of each reduced half an inch from the one directly under it.

The lower tuyere was from 3 to 4 inches in diameter, according to diameter of cupola, and the top one, one inch in diameter. A sufficient number of these tuyeres were placed in a cupola to admit a proper volume of blast for melting ; the object of these tuyeres being to distribute the blast to different parts of the bed in a sufficient volume to produce a rapid and thorough combustion of the fuel. This arrangement gave excellent results in cupolas of large diameter, but was not so satisfactory in small cupolas, as the tendency to bridge was increased by the inside air chamber and arrangement of tuyeres.

The cupola was designed for melting with coke only, and its use was restricted to the West, the greater number of them being used in Cincinnati and vicinity, where some are probably still in use, but most of them have been replaced by more modern cupolas.

The next patent cupola to come into prominence was the Lawrence cupola, designed and patented by Mr. Frank Lawrence, foreman of the American Stove and Hollow Ware Co., Philadelphia, Pa.

This cupola was designed for melting with coal or coke, and was quite extensively used both in this country and Canada. Its principal feature was a reducing tuyere, consisting of an opening 3 or 4 inches square, directly over which was an up-

right slot opening 10 to 12 inches long and 1 to $1\frac{1}{2}$ inches wide at the bottom, and tapering to a point at the top. These tuyeres, like the Truesdale, were supplied with air from an inside air chamber, and were designed to distribute the blast to produce a more rapid and thorough combustion than when all the blast was admitted at the same level. The cupola was generally boshed and the casing of the larger one was enlarged in the center, giving them an egg-shape between the top of the tuyeres and bottom of the stack, the charging door being placed in the stack. The cupola, when of good size, was the most rapid melter with coal ever designed, and was quite extensively used with this fuel.

Another cupola that attracted some attention was the Pevie cupola, designed by Mr. Pevie, a practical foundryman of a small town in Maine. This cupola was an oblong or flat one from 20 to 30 inches wide and from 4 to 6 feet long. Blast was admitted to it through a horizontal slot tuyere placed on each side and extending the full length of the cupola. The object of this construction was to force blast to the center of the cupola and produce even melting, which it no doubt did. But the tendency of the cupola to bridge was so great that it never came into general use, only a few of them being placed in foundries. Of these I have seen only four, one of which was in Mr. Pevie's own foundry, and judging from the number of cupola salamanders lying around, the inventor had not himself been able to overcome the tendency of the cupola to bridge.

Another cupola, or rather tuyere, which came into prominence in Philadelphia and vicinity was "The Dougherty," designed by Mr. Dougherty, of the firm of Bement and Dougherty. This improvement consisted of placing tuyeres in a cupola in such a manner as to give to the blast a circling or swirling motion around the cupola through the stock, in place of passing straight in and up through the stock. This arrangement for some time was considered to improve the melting, and many of these tuyeres were placed in cupolas; but after a thorough test there proved to be nothing in this motion given to

the blast, and, like many other improvements, the tuyere was abandoned.

All of these cupolas that met with any success depended for this upon the shape of the lining or arrangement of the tuyeres, and when these were maintained as originally designed good results in melting were obtained. But when placed in the hands of the average melter these conditions were ignored. Linings were permitted to get out of shape, tuyeres closed up or collapsed, directions for melting were not followed, and the cupola sooner or later in a vast majority of cases proved a complete failure and was changed to a plain cupola or replaced with the old-fashioned straight, round cupola, which demonstrates that fancy shapes in linings or the distribution of blast to the bed through numerous small or fancy shaped tuyeres, is not practical in cupola practice, and sooner or later proves a complete failure.

Following these fancy-shaped and numerous-tuyered cupolas came the "Colliau" plain round cupola, designed by Mr. Colliau, and first introduced about 1874 or 75. This cupola was designed to be a fast and economical melter as well as a continuous melter. But when first introduced it proved such a complete failure that Mr. Colliau's financial partner committed suicide and Mr. Colliau himself was on the verge of bankruptcy; but he persevered, and after numerous changes finally succeeded in making it the leading cupola of his time and of the present time.

The cupola, when first introduced, presented a number of new features in cupola construction and management, among which were a hot blast, a double row of tuyeres, the tapping of slag, etc.

The hot blast was to be produced by extending the air chamber from the bottom of the cupola up to near the charging door, on the outside, and heating the blast with heat escaping through the cupola shell. The heat escaping through the shell was found to be insufficient to heat the blast, and this feature was a complete failure, and after constructing a few

cupolas on this plan it was abandoned as impracticable. Had Mr. Colliau applied this theory to some of the old-fashioned stave cupolas, in place of a tight boiler plate casing, he might have met with more success, and he probably got his idea from these cupolas, for I have seen sufficient heat escape from them to at least warm a blast, if not heat it, by surrounding the entire cupola with a belt air chamber and passing the blast through it before entering the eupola through the small tuyeres then in use. The double rows of tuyeres were also a failure when first introduced, and it was found to be almost impossible to make hot iron with double the amount of fuel required for a bed to make hot iron with a single row of tuyeres, and the use of the cupola was restricted to foundries making heavy work and not requiring very hot iron.

This objectionable feature was finally overcome by reducing the size of the upper row and placing them nearer to the lower row or lower in the cupola. The tapping of slag and the continuous melting was a success from the beginning and this was all that saved the cupola from a complete failure.

The tapping of slag from blast furnaces had long been in vogue in this country, but Mr. Colliau was the first to apply this system of melting to cupolas, and it proved a decided advantage in long heats, for prior to its introduction it was almost impossible to run a small cupola for a greater length of time than two hours, or a large one for more than four, and do good melting.

Mr. Colliau also changed the form of cupola supports, bottom doors, air chambers, adopted a scale of heights for cupolas of different diameters, and probably did more to advance cupola construction in this country than any other cupola designer.

His designs both before and after his death were adopted by other cupola manufacturers, and the general construction of cupolas at the present time is upon the Colliau plan.

The double row of tuyeres was not original with Mr. Colliau. They had been used in France, prior to his introduction of

them in this country, and the Truesdale and Lawrence tuyeres were practically on the same principle, applied in a little different form, but the Colliau arrangement was not so apt to close up and get out of order, and was more practical and has come into general use.

The utility of these tuyeres depends to a large extent upon the conditions under which they are used. They require a higher bed and are more destructive to lining material than the single row of tuyeres, and in foundries employing a small number of molders and running short heats they are an expensive luxury.

The manufacturers of cupolas have realized this fact and arranged a device for closing the top row when large heats for the size of cupola are not to be melted, and in fully nine-tenths of these cupolas in use, I find the second row either permanently or temporarily closed, which places the cupola in the same condition as the improved cupola of "40 years ago."

The double row melts iron more rapidly than the single row in cupolas of the same diameter, and a third and fourth row have been added to advantage in this respect when properly arranged. But the destruction of lining material from the use of these numerous tuyeres is very heavy and the amount of fuel required is greatly increased.

In foundries employing a large number of molders and melting heavy heats, rapid melting increases the output of the foundry to a considerable extent by allowing more time for molding work, and these numerous tuyere cupolas are being used with good results in foundries of this class; the heavy destruction of lining material and increased expenses of melting being more than overcome by the increased output of the foundry.

It is therefore a matter for every founder to decide whether it is more economical to melt fast or slow, the actual cost of cupola lining, etc., being a secondary consideration when offset by other conditions.

I might describe numerous other cupolas I have seen in

operation, but those just described embrace all the principles embodied in other new designs of cupolas and arrangement of tuyeres, nearly all of which have gone out of use or are being used only to save expense of replacing them with other cupolas.

After all the supposed improvements we have practically come back to the plain round cupola of 40 years ago, with practically no improvements, save the enlargement of tuyeres and increase in height of cupola. These improvements have made the common round cupola superior to any other for general foundry use and with the improvement made in blast machinery enormous quantities of iron may be melted in it in a very short time, with the single row tuyere cupola, and with the double and triple tuyere arrangement more iron may be melted per hour than the output of our most improved blast furnaces for the same length of time.

The common round cupolas with the single or double row of tuyeres as desired are now manufactured by numerous cupola manufacturers located in different parts of the country, and founders who contemplate putting in new cupolas will probably find it cheaper to order a cupola with such changes in its construction as they may desire than to go to the expense of making patterns and constructing their own cupola.

CHAPTER III.

CONSTRUCTING A CUPOLA.

WHEN about to construct a cupola to melt iron for foundry work, the first thing to be decided on is the proper location. In deciding this a number of points are to be taken into consideration, the two most important of which are the getting of the stock to the cupola and the taking away of the molten iron. It should be borne in mind that there is more material to be taken to a cupola than is to be taken away from it. For this reason the cupola should be located as convenient to the stock as possible. It must also be borne in mind that the object in constructing a cupola is to obtain fluid molten iron for the work to be cast, and if the cupola is located at so great a distance from the moulding floors that the molten metal loses its fluidity before it can be poured into the mould, the cupola fails in the purpose for which it was constructed.

If the work to be cast is heavy and the greater part of the molten metal is handled by traveling or swinging cranes, the small work may be placed near the cupola and the cupola located at one side or end of the foundry near the yard. But if the work is all light hand-ladle or small bull-ladle work, the cupola should be located near the centre of the moulding-room so that the molten iron may be rapidly conveyed to the moulds in all parts of the room.

SCAFFOLD.

It is often found difficult, owing to the shape of the moulding-room and location of the yard, to place the cupola conveniently for getting the stock to it and the molten iron away from it. When this is the case, means must be provided for getting

the stock to the cupola and the cupola located at a point from which the molten metal can be rapidly conveyed to the moulds. At the present low price of wrought iron and steel, a fire proof cupola scaffold can be constructed at a very moderate cost, and the difficulty of locating the cupola convenient to the yard may be overcome by constructing a scaffold of a sufficient size to take the place of a yard for iron and fuel. The scaffold may be constructed under the foundry roof and made of proper size to hold one or two cars of coal or coke, a hundred tons of pig and scrap iron and all the necessary material for a cupola. The space under the scaffold can be utilized as moulding floors for light work or for core benches, core oven, ladle oven, sand-bins, etc. The cupola and its supplies are then under roof, and there is no trouble from cupola men staying at home in bad weather, as is often the case when the cupola and stock are out of doors.

When this arrangement is adopted, an endless chain or bucket elevator should be constructed to convey the coal or coke to the scaffold as fast as it is shoveled from the truck or car. Another elevator should be provided for pig and scrap iron, and as the iron is thrown from the car it is broken and at once placed upon the scaffold convenient for melting. This arrangement saves considerable expense for labor in the rehandling of iron and fuel, and also prevents the loss of a large amount of iron and fuel annually tramped into the mud in the yard and lost. The saving in labor and stock in a short time will pay the extra expense incurred in constructing this kind of scaffold.

CUPOLA FOUNDATION.

Too much care cannot be taken in putting in a cupola foundation, for the weight of a cupola and stack, when lined with fire-brick to the top, amounts to many tons, and when loaded with fuel and iron for a heat to many tons more. If the foundation gives way and the cast iron cupola bottom is broken by uneven settling, the cupola is rendered practically worthless, for it is impossible to replace the bottom with a new one with-

out taking out the entire lining, which entails much expense, and it is almost impossible to bolt or brace the plate so as to keep it in place.

The foundation should be built of solid stone work, and if a good foundation cannot be had, piles must be driven. Separate stone piers should never be built for each column or post, for they frequently settle unevenly and crack the bottom plate. Uneven settling and breaking of the bottom are, to a large extent, prevented by placing a heavy cast iron ring upon the stone work upon which to set the cupola supports. This ring should be placed several inches below the floor to prevent it being warped and broken by the heat in the dump.

When brick walls are constructed for the support of a cupola, the bottom plate is made square, from two to three inches thick and strongly ribbed or supported by railroad iron between the walls, to prevent breaking. The walls do not admit of sufficient freedom in removing the dump and for this reason are, at the present time, seldom used in the construction of cupolas. Even when the cupola is set so low that a pit is required for the removal of the dump, the iron supports are used and the pit walls built outside of them. When the round cast iron columns are employed, the plate must be made square or with a projection for each column, to admit of the columns being placed at a sufficient distance apart to let the bottom doors swing between them. The best supports for a cupola are the T-shaped posts. They take up less room under the cupola and are less in the way when removing the dump than the round columns, and when slightly curved at the top, can be placed at a sufficient distance apart to permit of the drop doors swinging between them. When these posts are used, the bottom plate is made round and of only a slightly larger diameter than the cupola shell or air chamber, and when made of good iron and the foundation plate is used, the bottom plate does not require to be more than $1\frac{1}{2}$ or 2 inches thick for the largest sized cupola. The supports when curved at the top must be bolted to the plate to hold them in place.

HEIGHT OF CUPOLA BOTTOM.

The height the bottom of a cupola or spout should be placed above the moulding floor or gangway, depends upon the class of work to be cast. For small hand-ladle work the proper height is 18 to 20 inches; for small bull-, and hand-ladle work 24 to 30 inches; and for large crane-ladle work three to five feet.

It is very difficult and dangerous to change ladles and catch a large stream from a high cupola in hand-ladles; and when pieces are only cast occasionally, requiring the use of a large crane-ladle, it is better to place the cupola low and dig a pit in front of it, in which to set the ladle when a large one is required for the work.

When the cupola is set low, room must be made for the removal of the dump. This may be done by constructing a wall in front of the cupola to keep up the floor under the spout, and lowering the floor under and around the back part of the cupola. When the cupola is so situated that this can not be done, a pit should be constructed for the removal of the dump.

BOTTOM DOORS.

For cupolas of small diameter, but one bottom drop door is used. But when the cupola is of large diameter the door, if made in one piece, would be so large that there would not be room for it to swing clear of the foundation without setting the cupola too high, and the door would be very heavy and difficult to raise into place. For large cupolas the door is cut in the middle and one-half hung to the bottom on each side. Four and six doors are sometimes used, but they are always in the way when taking out the dump, and require more care in putting in place and supporting.

The doors are generally made of cast iron, and vary in thickness from a half-inch to an inch and a half, and are frequently very heavy and difficult to raise into place. If the doors are large they are much lighter and easier to handle when made of wrought iron, and if properly braced answer the

purpose equally as well as the stiffer cast iron ones. If the lugs on the bottom plate are set well back from the opening, and the lugs on the doors made long, the doors drop further away from the heat of the dump, and may be swung back and propped up out of the way when removing the dump.

DEVICES FOR RAISING THE BOTTOM DOORS.

A number of devices have been used for raising the bottom doors of cupolas into place, and thus avoiding the trouble and labor of raising them by hand. One of the oldest of these devices is a long bar, one end of which is bolted to the under side of the door, on the other end is cast a weight or ball almost sufficient to balance the door upon its hinges when raised. When the door is down the bar stands up alongside of the cupola, and when it is desired to raise the door the bar and weight are swung downward. As the weight descends the door is balanced upon its hinges and swings up into place, where it is supported by a prop or other support. This device, when properly arranged and in good order, raises the door very easily and quickly into place, but it is continually getting out of order. The sudden dropping of the door in dumping and the consequent sudden upward jerk given to the heavy weight on the end of the bar frequently breaks the bar near the end attached to the door or breaks the bolts by which the bar is attached to the door, and the door is sometimes broken by the bar. For these reasons this device is very little used.

Another device, and probably the best one for raising heavy doors, is to cast large lugs with a large hole in them, on the bottom and the door, and put in an inch and a half shaft of a sufficient length to have one end extend out a few inches beyond the edge of the bottom plate. The door is keyed fast upon the shaft, and the shaft turns in the lugs upon the bottom when the door is raised or dropped. An arm or crank is placed upon the end of the shaft, pointing in the same direction from the shaft as the door. When the door is down the arm hangs down alongside of the iron post or column

supporting the cupola and is out of the way in removing the dump, and when the door is up the arm is up alongside of the bottom plate, out of the way of putting in the bottom props. The door is raised by a pair of endless chain pulley blocks attached to the under side of the scaffold floor at the top and the end of the arm at the bottom, and it is only necessary to draw up the arm with the chain to raise the door into place. This is one of the best devices we have seen for raising heavy doors.

Another one, equally good for small doors and less expensive, is to make the end of the shaft square and raise the door by hand with a bar or wrench five or six feet long, placed upon the end of the shaft. The bar is placed upon the shaft in an upright position, and by drawing down the end of the bar the door is swung up into place by the rotation of the shaft on to which it is keyed. When the door is in place the bar is removed from the end of the shaft, and is not at all in the way of handling the iron or managing the cupola.

CASING.

The casing or shell of the modern cupola and stack is made of iron or steel boiler plate, riveted together with one or two rows of rivets at each seam. The thickness of the plate required depends upon the diameter and height of the cupola and stack. The lining in the stack is seldom renewed, while the lining in the cupola is often removed every few months and replaced with a new one, and the casing must be of a sufficient thickness to support the stack and lining when the cupola lining is removed. The strain upon the casing due to expansion and shrinkage is not very great when properly lined; but when improperly lined with a poor quality of fire-brick, the expansion may be so great as to tear apart the strongest kind of casing. The only way to prevent this is to take care in selecting the fire-brick, and in laying up the lining. The greatest wear and tendency to rust are in the bottom sheet, and it is also weakened by cutting in the front, tuyere and slag holes, and should be made of heavier iron than any other part of the casing. Plate

of $\frac{1}{4}$ inch or $\frac{3}{8}$ inch thickness is heavy enough for almost any sized cupola. The cupola and stack casing are generally made in one piece, the cupola ending at the charging door and the stack beginning at the same point. The stack may be contracted above or below the charging door, and made of smaller diameter than the cupola. This gives a better draught and requires less material for casing and lining; but it also increases the number of sparks thrown from the cupola when in blast. Where sparks are very objectionable, as in closely built up neighborhoods, it is better to make the cupola and stack of the same diameter, or to enlarge the stack from the bottom of the charging door. This may be done by placing a cast iron ring upon the top of the cupola shell, and supporting it by brackets riveted to the shell, and placing the stack shell upon the ring. The sparks then fall back into the cupola if the stack is of a good height, and very few are thrown out at the top.

The height of a cupola is the distance from the top of the bottom plate to the bottom of the charging aperture. Many plans have been devised for utilizing the waste heat from a cupola, but the only practical means so far discovered is to construct a high cupola. The heat lost in a low cupola is then utilized in heating the stock in the cupola before it escapes from it. But all the heat is not utilized in this way, for a great deal of gas escapes unconsumed. This is shown by the increase in flame as the stock settles in the cupola to a point at which the oxygen from the charging aperture combines with the escaping gas in sufficient quantity to ignite it, when it burns with a fierce flame above the stock. Still a great deal more heat is utilized in a high cupola than in a low one.

It is well known among iron founders that a high cupola will melt more iron in a given time and with less fuel than a low one of the same diameter. Therefore the charging aperture should be placed at the highest practicable point. There is a limit to the height at which the aperture in a small cupola can be placed, for where the diameter is small the iron in settling frequently lodges against the lining and hangs up the stock.

When this occurs the stock has to be dislodged by a long bar worked down through from the charging aperture. If the aperture is placed at too great a height and the lodgment takes place near the bottom, the trouble cannot be remedied with a bar, and melting stops. Cupolas of large diameter may be made of almost any height desired, but there seems to be a limit to the height at which heat is produced in a cupola by the escaping gases, and we have arranged the following table from practical observation, giving the approximate height and size of door for cupolas of different diameters :

Diameter Inside Lining, Inches.	Height of Cupola Feet.	Size of Charging Door, Inches.	Melting Capacity per Hour, Tons.	Melting Capacity per Heat, Tons.
18	6—7	15 x 18	$\frac{1}{4}$ — $\frac{3}{4}$	1—2
20	7—8	18 x 20	$\frac{1}{2}$ —1	2—3
24	8—9	20 x 24	1—2	3—5
30	9—12	24 x 24	2—5	4—10
40	12—15	30 x 36	4—8	8—20
50	15—18	30 x 40	6—14	15—40
60	16—20	30 x 45	8—16	25—60

The melting capacity of a cupola varies with the kind of fuel used. One-fourth more iron can be melted per hour with coke than with coal, and the melting capacity per heat is greatly increased by the tapping of slag and the number of tuyeres.

CHARGING DOOR.

The charging door may be made in one or two sections and lined with fire-brick or daubed with fire-clay; or it may be made of wire gauze placed in an iron frame. The charging door is of but little importance in melting, as it is seldom closed during the greater part of the heat, and is only of service to give draught to the cupola when lighting up, and to prevent sparks being thrown upon the scaffold during the latter part of the heat.

AIR CHAMBER.

The air chamber for supplying the tuyeres with blast may be constructed either outside or inside the cupola shell. When

placed inside, the cupola must be boshed and the lining contracted at the bottom to make room for the chamber without enlarging the diameter of the cupola casing. When the cupola is large this can readily be done, and the boshing of the cupola increases its melting capacity; but small cupolas cannot be contracted at the bottom to a sufficient extent to admit of an air chamber being placed inside without interfering with the dumping of the cupola. When placed inside, the chamber may be formed with cast iron staves made to rest upon the bottom plate at one end and against the casing at the other. The staves are flanged to overlap each other with a putty joint, and when new make a very nice air chamber. But when the lining becomes thin they become heated and frequently warp or break, and permit the blast to escape through the lining to so great an extent that the lining has to be removed and the staves replaced with new ones.

The air chamber, when constructed inside the casing, should be made of boiler plate, and securely riveted to the casing to hold it in place and prevent leakage of blast through the lining. It must be constructed of a form to correspond with the boshing of the cupola, and of a size to supply a sufficient quantity of blast to all the tuyeres. If these conditions cannot be met without reducing the cupola below 40 inches diameter at the tuyeres, then the air chamber should be placed on the outside, and any desired boshing of the cupola made by placing common red brick behind the fire-brick lining.

When the air chamber is placed upon the outside of the shell, it may be formed by a round cast iron or sheet metal pipe extending around the cupola, with branches extending down to each tuyere; or it may be made of boiler plate and riveted to the shell. The great objection to the round or overhead air chamber is the numerous joints required in connecting it with each tuyere. These joints require continual looking after to prevent leakage of blast, and in many cases they are not examined from one year's end to another, and a large per cent. of the blast is frequently lost through leaky joints. The

best air chambers are those made of boiler plate and riveted to the cupola shell and securely corked. These air chambers are made of any shape that may suit the fancy of the constructor, and in many cases are very much in the way of the melter in making up the cupola and of the moulders in removing the molten iron. They should not be made to extend out from the shell more than six inches, and any air capacity desired given by extending the chamber up or down the shell. The air capacity should not be less than three or four times the area of the outlet of the blower, and may be much larger. The blast should be admitted to the chamber from the top on each side of the cupola. This arrangement places the pipes out of the way where they are least likely to be knocked and injured. When the tuyeres are placed low, the chamber may be made to extend down to the bottom plate. In this case, the bottom plate must be made larger and the chamber cut away front and back for the tap and slag holes.

When the tuyeres are placed high, the chamber should be placed up out of the way of the tap and slag holes, and riveted to the shell at both top and bottom. An opening should be made in the air chamber under each tuyere and covered with a piece of sheet lead, so that any molten iron or slag running into the chamber from the tuyeres will flow out and not injure or fill up the chamber. An opening should be placed in front of each tuyere for giving draught to the cupola when lighting up, and for the removal of any iron or slag that may run into the tuyere during a heat. These openings should not be made over three or four inches in diameter, and should each be provided with a tight-fitting door to prevent the escape of the blast.

TAP HOLE.

One or more orifices are placed in the casing at the bottom plate for the removal of the molten iron from the cupola. These openings are known as tap holes, and in the casing are from six to eight inches wide and seven to nine inches high, curved or rounded at the top. The opening through the

cupola lining is generally formed by the brick and presents a very ragged appearance after the lining has been in use a short time. This opening should be lined with a cast iron casting bolted to the cupola casing, and made to extend almost through the lining. The casing should be made slightly tapering with the large end inside, or ribbed, to prevent the front being pushed out by the pressure of molten iron retained in the cupola. For small cupolas, or a large cupola from which the iron is removed in large ladles, but one tap hole is required. But large cupolas melting over eight tons of iron per hour, from which the iron is taken in hand ladles, require two tap holes. Two tap holes are sometimes placed in a cupola on opposite sides to shorten the distance of carrying the iron to the moulds. And two tap holes are also sometimes placed side by side so that each may be kept in better order throughout the heat. This is bad practice, for if the front is properly put in, one tap hole will run off all the iron a cupola is capable of melting. When two tap holes are put in they should be placed one in front and the other in the back or side of the cupola, so that the moulders will not be in each other's way when catching-in.

THE SPOUT.

A short spout must be provided for conveying the molten iron from the tap hole to the ladles. This spout is generally made of cast iron, and is from six to eight inches wide with sides from three to six inches high, and for small ladle work is from one to two feet long. For large ladle work it is made much longer. In some foundries where a long spout is only occasionally required, the spout is made in two sections and put together with cleats, so that an additional section may be put up to fill a large ladle and taken down when it is filled. The spout should be long enough to throw the stream near the center of the ladle when filling. In a great many foundries the spout is laid upon the bottom plate, and only held in place by the making up of the front, and is removed after each heat.

This entails the loss of a great deal of spout material each heat, and sometimes the spout is struck in the careless handling of ladles and knocked out of place, when much damage may be done. When not in the way of removing the dump, the spout should be securely bolted to the bottom plate.

When it is desired to run a very small cupola for a greater length of time than an hour and a half, or a large cupola for a longer time than two hours and a half, slag must be tapped to remove the ash of the fuel and dross of the iron from the cupola, to prevent bridging over and bunging up. The slag hole from which the slag is tapped is placed between the tuyeres, and below the lower level of the lower row of tuyeres. A hole is cut through the casing and lining from three to four inches in diameter, and a short spout or apron is provided to carry the slag out, so that it will fall clear of the bottom plate. The slag hole should be placed at the back of the cupola, or at the greatest possible distance from the tap hole, so that the slag will not be in the way of the moulders when catching the iron. The height at which a slag hole should be placed above the sand bottom depends upon how the iron is tapped. The slag in a cupola drops to the bottom and floats upon the surface of the molten metal, and rises and falls with it in the cupola. If the molten iron is held in the cupola until a large body accumulates, the slag hole must be placed high and the slag tapped when it has risen upon the surface of the molten iron to the slag hole. When the iron is withdrawn, the slag remaining in the cupola falls below the slag hole, and the hole must be closed with a bod to prevent the escape of blast. If the iron is drawn from the cupola as fast as melted, the slag hole is placed two or three inches above the sand bottom at the back of the cupola. The slag then lies upon the molten iron, or upon the sand bottom, and the slag hole may be opened as soon as slag has formed, and allowed to remain open throughout the heat.

TUYERES.

A number of openings are made through the casing and lining near the bottom of the cupola for admitting the blast into the cupola from the air chamber or blast pipe. These openings are known as tuyeres. Tuyeres have been designed of all shapes and sizes, and have been placed in cupolas in almost every conceivable position, so there is little to be learned by experimenting with them, and the only things to be considered are the number, shape, size and position of tuyeres for different sized cupolas. For a small cupola, two tuyeres are sufficient. A greater number promotes bridging. They should be placed in the cupola on opposite sides, so that the blast will meet in the center of the cupola, and not be thrown against the lining at any one point with great force. The best shape for a small cupola is a triangular or upright-slot tuyere. These cause less bridging than the flat-slot or oval tuyere, and in small cupolas make but little difference in the amount of fuel required for the bed. When only two tuyeres are provided a belt air chamber around the cupola is not required, and the blast pipes are generally connected direct with each tuyere. In large cupolas the shape of the tuyeres selected makes but little difference in the melting, so long as they are of sufficient size and number to admit the proper amount of blast to the cupola, and so arranged as to distribute it evenly to the stock. The flat-slot or oval tuyeres are generally selected for the reason that they require less bed than the upright-slot tuyere.

The number of tuyeres required varies from four to eight, according to the size of the cupola and tuyeres. They should be of the same size and placed at uniform distances apart. A tuyere should never be placed directly over the tap or slag hole. The combined tuyere area should be from two to three times greater than the area of the blower outlet. The tuyere boxes or casings are made of cast-iron, and should be bolted to the cupola shell to prevent any escape of blast through the lining when it becomes old and shaky, or when lined with poor material and the grouting works out, as is sometimes the case.

The height at which tuyeres are placed in cupolas above the sand bottom varies from one or two inches to five feet, and there is a wide difference of opinion among founders as to the height at which they should be placed. When the tuyeres are placed low the iron must be drawn from the cupola as fast as melted, to prevent it running into the tuyeres. In foundries where the iron is all handled in hand-landles this can readily be done, and the tuyeres are placed low to reduce the quantity of fuel in the bed and make hot iron. In foundries in which heavy work is cast, and the iron handled in large ladles, the tuyeres are placed high, so that a large amount of iron may be accumulated in the cupola to fill a large ladle for a heavy piece of work.

We do not believe in high tuyeres, and claim they should never be placed more than 10 or 12 inches above the sand bottom for any kind of work; and if slag is not to be tapped from the cupola, they should not be placed more than two or three inches above the sand bottom. In stove foundries, in which cupolas of large diameter are employed and hot iron required throughout the heat, the tuyeres are placed so low that the sand bottom is made up to within one inch of the bottom of the tuyeres on the back and two or three inches at the front. This gives plenty of room below the tuyeres for holding iron without danger of it running into the tuyeres. In cupolas of small diameter two inches is allowed at the back and three or four inches at the front. This insures a hot, even iron throughout the heat, if the cupola is properly charged, and a much less quantity of fuel is required for the bed than if the tuyeres were placed high. Molten iron is never retained in the cupola for this class of work, and the tap hole is made of a size to let the iron out as fast as melted and the stream kept running throughout the heat.

Cupolas with high tuyeres are not employed for this class of work, for they do not produce a hot fluid iron throughout a heat without the use of an extraordinarily large per cent. of fuel, and when the tuyeres are extremely high they do not

make a hot iron with any amount of fuel. Nothing is gained by holding molten iron in a cupola, for iron can be kept hotter in a ladle than in a cupola, and melted hotter with low than high tuyeres, and a cupola is kept in better melting condition throughout a heat by tapping the iron as fast as melted.

TWO OR MORE ROWS OF TUYERES.

It is the common practice to place all the tuyeres in a cupola at the same level, or in one row extending around the cupola. But two or more rows are frequently placed one above the other. When a large number of rows are employed they decrease in area gradually from the lower to the top tuyere, and the rows are generally placed very close together. When two rows are put in, the second row is made from one-half to one-tenth the area of the first row, and the two rows are placed from 8 to 18 inches apart. If the area of the second row is one-half that of the first, it is generally placed from 8 to 10 inches above the first row, and only when the tuyeres are very small are they placed at a greater height above the first row. When three rows are put in, the second row is made one-half the area of the first row, and the third row one-fourth the area of the second, and the rows are placed from 6 to 10 inches apart. When tuyeres are placed in a cupola all the way up to the charging door, those above the first or second row are made one inch diameter, and are placed from 12 to 14 inches above each other.

The tuyere in the upper row may be placed directly over the tuyere in the row beneath it, or may be placed between two lower ones. Some cupola men claim that much better results are obtained by this latter plan, but we have never observed that it made any difference whether they were placed over or between those of the lower rows.

Faster melting is secured with two or three rows of tuyeres than with one row in cupola of the same diameter, and the melting capacity per hour is increased about one-fourth in melting large heats. When melting a small heat for the size

of the cupola, nothing is gained by the additional rows of tuyeres, since a much larger quantity of fuel is required in the bed, for which there is no recompense by saving of fuel in the charges through the heat, and fast melting is seldom any great object in small heats.

LINING.

The casing may be lined with fire-brick, soapstone or other refractory substances. In localities where fire-brick cannot be obtained, native refractory materials are used; but fire-brick are to be preferred to native mineral substances. Cupola brick are now made of almost any shape or size required in cupola lining, and can be purchased at as reasonable a price as the common straight fire-brick. The curved brick, laid flat, make a more compact and durable lining than the wedge-shaped brick set on end, and are most generally used. When laying up a lining, the grouting or mortar used should be of the same refractory material as the brick, so that it will not burn out and leave crevices between the brick, into which the flame penetrates and burns away the edges of the brick. This material is made into a thin grout, and a thin layer is spread upon the bottom plate. The brick is then taken in the hand, one end dipped in the grout, and laid in the grout upon the plate. When a course or circle has been laid up, the top is slushed with grout to fill up all the cracks and joints, and the next course is laid up and grouted in the same way. The joints are broken at each course, and the brick are laid close together to make the crevice between them as small as possible, and prevent the flame burning away the corners in case the grouting material is not good and burns out.

Brick that do not expand when heated are laid close to the casing. Those that do expand are laid from a fourth of an inch to an inch from the casing, to give room for expansion, and the space is filled in with sand or grout. Brick of unknown properties should always be laid a short distance from the casing, to prevent the latter being burst by expansion of the lining.

The lining is made of one thickness of brick, and a brick is selected of a size to give the desired thickness of lining. In small cupolas, a four or five-inch lining is used, and in large cupolas a six or nine-inch lining. A heavier lining than nine

FIG. 1.

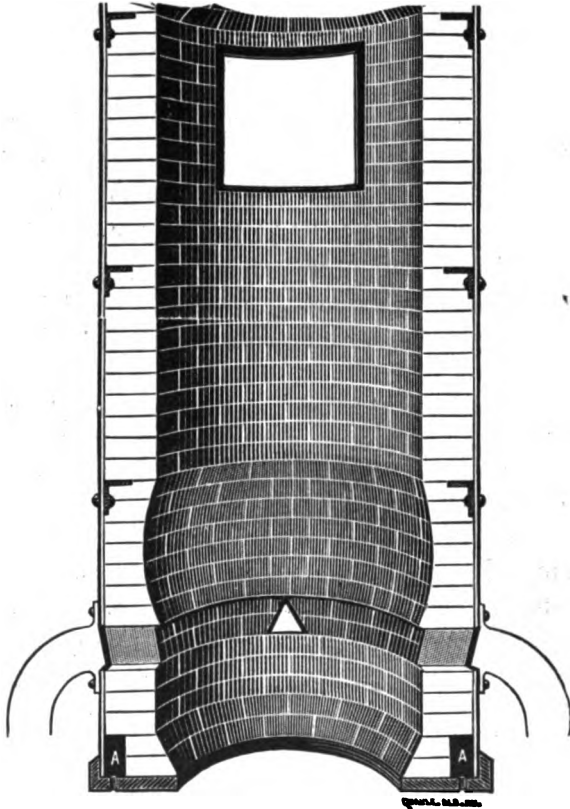

SECTIONAL VIEW OF CUPOLA.

inches is seldom put in, except to reduce the diameter of the cupola or prevent the heating of the shell. In these cases, a filling or false lining of common red brick is put in between the fire-brick and shell. The stack lining is seldom made heavier

than four inches for any sized cupola, as the wear upon it is not very great, and a four-inch lining lasts for a number of years. The stack lining is laid up and grouted in the same way as the cupola lining.

ARRANGEMENT OF BRACKETS, ETC.

In Fig. 1 is shown the manner in which brackets or angle iron are put into a cupola for the support of the lining in sections upon the casing. The brackets are made of heavy boiler plate from five to six inches wide, circled to fit the casing and bent at a square angle. The part riveted to the casing is made four inches long and secured to the casing with two or three rivets. The bracket or shelf for the support of the lining is made from one and a half to two inches long. The brackets are placed about two feet apart around the casing and in rows from two to three feet above each other. These brackets are but little in the way when laying up a lining, and support the latter so that a section may be taken out and replaced without disturbing the remainder of the lining.

Angle iron is by many preferred to brackets for the support of the lining. It is put in bands extending all the way around the casing and riveted to it. These bands not only support the lining but act as a brace to the casing, and in some respects are a better support for the lining than brackets. They catch and hold in place all the grouting or sand that may work out of the lining between the casing, and give a more even support to the lining, but with their use it is sometimes more difficult to fit the brick around when laying up a lining. Still, angle iron has generally taken the place of brackets and is put in all the modern cupolas. The brackets or angle iron should not be made to extend out from the casing more than one and a half or two inches, for if they do they are liable to be burned off when the lining becomes thin and let the iron or heat through to the casing. One and a half inches are sufficient to support the lining if the brick form a circle to fit the casing. No supports should be put in at the melting zone, for the lining frequently

burns very thin at this point, even in a single heat. It is not necessary to put in any below the melting zone, and the first one should be placed at the upper edge of the zone, and from this up they should be put in at every two or three feet.

The weight of brick placed upon the lower courses in a cupola lining is sufficient to crush most of the soft cupola brick, and were it not for the support given to three sides of them in the lining they would, by the great weight placed upon them, be reduced to a powder. As a lining burns out it becomes thin more rapidly at the bottom, and it often happens that the lining at the melting zone is reduced to one-half its thickness, or even less, in a few heats, and this reduced lining often has to support a lining of almost full thickness for the entire cupola, and in some cases also the stack lining. The cohesive force of these bricks is reduced by the intense heat in the cupola, and when subjected to so great a pressure and heated they are crushed and the lining gradually settles and becomes shaky. This settling is so great with some qualities of brick that in cupolas having no frame riveted to the casing around the charging aperture, the arch over the door frequently settles so low that it becomes necessary to rebuild it to maintain the full size of the opening.

Brick do not give the best results when subjected to so great a pressure and heated to a high temperature. Therefore, in all cupolas, brackets or angle iron should be put in every two or three feet for the support of the lining on the casing, and the casing should be made heavy enough to support the entire lining when a section has been burned out or removed.

In the illustration (Fig. 1) is also shown a way for reducing the size and weight of the bottom doors and preventing the casing from rusting off at the bottom. In many of the large cupolas requiring heavy sand bottoms, the bottom plate can be made to extend into the cupola from three to six inches all round without in the least interfering with dumping, and the first few courses of brick sloped back from the edge of the plate to the regular thickness of lining to prevent sand lodging on the edges

of the plate around the lining. By this arrangement in large cupolas, the diameter of the doors may be reduced from six to ten inches, and very much lightened, and less sand will be required, for the sand bottom and the dump falls as freely as when the doors are the full size of the cupola.

Cupolas that are not in constant use absorb a great deal of moisture into the lining and are constantly wet around the bottom plate, and light casings are eaten away by rust in a short time. To prevent this the first one or two courses of brick can be laid a few inches from the casing and a small air chamber formed around the cupola at this point. If this chamber is supplied with air from a few small holes through the iron bottom or casing, the latter is kept dry and rusting is prevented.

In the illustration (Fig. 1) is shown the triangular-shaped tuyere in position in the lining. This tuyere prevents bridging to a greater extent than any other, and is, for a small cupola, one of the very best shapes. It is formed with a cast iron frame set in the lining, and each tuyere may be connected with a separate pipe, as shown, or they may be connected with an air belt extending around the cupola.

Bottom plates may be cast with a light flange around the edge, as shown in the illustration (Fig. 1), or made perfectly flat on top; but it is better to cast them with a small flange or bead for holding the shell in place upon the plate, and thus make the cupola to have a more finished look around the bottom.

FIRE PROOF SCAFFOLDS.

The charging door or opening through which fuel and iron are charged into a cupola is placed at so great a height from the floor that it is necessary to construct a platform or scaffold, upon which to place the stock, and from which to charge it into the cupola. For heavy work, this scaffold is generally placed on three sides of the cupola, leaving the front clear for the swinging of crane ladles to and from the spout; but for light work the scaffold frequently extends all the way around

the cupola to give more room for placing stock upon it. The distance the floor of a scaffold is generally placed below the charging door is about two feet, but that distance varies, and floors are frequently placed on a level with the door or three or four feet below it to suit the kind of iron to be melted or the facilities for placing stock upon the scaffold from the yard. The scaffold and its supports are more exposed to fire than almost any other part of a foundry, for live sparks are thrown from the charging door upon the scaffold floor, and molten iron, slag, etc., are frequently thrown against its supports and the under side of the floor with considerable force when dumping the cupola. Numerous plans have been devised to make scaffolds fire-proof and prevent the foundry from being set on fire. In many of the wooden foundry buildings the scaffold is constructed entirely of wood, and to render it fire-proof, the supports and under side of the floor are covered with light sheet iron to protect them from molten iron, slag, etc., when dumping. The covering of the wood-work of a scaffold in this way is very bad practice, for while it protects the wood from direct contact with the fire, it also prevents it from being wetted, and in a short time the wood becomes very dry and very combustible. The thin covering of sheet iron is soon eaten away with rust, leaving holes through which sparks may pass and come in contact with the dry wood and ignite it under the sheet iron where it cannot be seen, and the cupola men, after wetting down the dump very carefully, may go home leaving a smouldering fire concealed by the sheet iron covering which may break forth during the night and destroy the foundry. It is better to leave all the wood-work entirely uncovered and exposed to the fire and heat, and wet it in exposed places before and after each heat; the wood is then kept dampened and is not so readily combustible as when covered with sheet iron, and if ignited the fire may be seen and extinguished before the men leave for home after their day's work is done. In many of the wooden foundry buildings the cupola is placed outside the foundry building and a small brick house

or room constructed for it and the molten iron run into the foundry by a cupola spout extending through the wall. In this way a scaffold may be made entirely fire-proof by putting in iron joist and an iron or brick floor, and putting on an iron roof. We saw a scaffold and cupola house at a small foundry in Detroit, Mich., about twenty years ago, that was constructed upon a novel plan and was perfectly fire-proof. The house was twelve feet square and constructed of brick, the scaffold floor was of iron and supported by iron joist, the walls were perpendicular to five feet above the scaffold floor, and from this point they were contracted and extended up to a sufficient height to form a stack three feet square at the top. The cupola was placed at one side of this room and the cupola-house, and the spout extended through the wall into the foundry; the open top of the cupola extended about two feet above the scaffold floor, and its stack was formed by the contracted walls of the cupola-house. There were no windows in the house, and only one opening above for placing stock upon the scaffold and one below for removing the dump and making up the cupola, both of which openings were fitted with iron door frames and doors, and could be tightly closed. When lighting up, the scaffold door was closed to give draught to the cupola, and when burned up the door was opened and the cupola charged from the scaffold. Sparks from the cupola when in blast fell upon the scaffold floor and were never thrown from the top of the stack or cupola-house upon the foundry roof or the roofs of adjoining buildings, and when the doors were closed the scaffold was as fire-proof as a brick stack. The great objection to this scaffold was the gas from the cupola upon the scaffold when the blast was on, and the intense heat upon the scaffold in warm weather or when the stock got low in the cupola.

The best and safest scaffolds are those constructed entirely of iron, or with brick floors and supported by iron columns, or brick walls and made of a sufficient size to admit of wood or other readily combustible cupola material being placed at a safe distance from the cupola. The cupola scaffold in the foundry

of Gould & Eberhardt, Newark, N. J., is constructed of iron supported by iron columns and brick walls, and is of sufficient size and strength to carry two car-loads of coke, one hundred tons of pig and scrap iron, and all the wood shavings and other materials required for the cupola. In the new iron foundry building recently erected by The Straight Line Engine Company, Syracuse, N. Y., the scaffold is constructed entirely of iron and supported by the iron columns which support the foundry roof. It extends the entire length of the foundry, affording ample room for storing iron, coke, wood, and all cupola supplies, thus doing away with a yard for storing such material, and placing them under the foundry roof and convenient for use. Scaffolds of this kind greatly reduce the expense of handling cupola stock, and also reduce the rate of insurance on foundry buildings.

CHAPTER IV.

CUPOLA TUYERES.

THE cupola furnace may be supplied with the air required for the combustion of the fuel by natural draft induced by a high stack, a vacuum created by a jet of steam, or by a forced blast from a fan or blower. In either case the air is generally admitted to the cupola through openings in the sides near the bottom. These openings are known as tuyeres or tuyere holes. The location, size, number and shape of these tuyeres are a matter of prime importance in constructing a cupola, and are a subject to which a great deal of attention has been given by eminent and practical foundrymen for years, and to these men is due the credit for the advancement made in the construction of cupolas.

It is only a few years since 10 to 15 tons was considered a large heat for a cupola, and when a large casting was to be poured two or more cupolas were run at the same time and the greater part of a day consumed in melting. Now 60 tons are melted in one cupola in four hours for light foundry work, and hundreds of tons are melted in one cupola in steel works without dropping the bottom. This improvement in melting is largely due to the improvement in the size, shape and arrangement of tuyeres.

There have been epidemics of tuyere inventing several times in this country in the past twenty-five years, and during these periods it has been almost impossible for an outsider to get a look into a cupola for fear the great secret of melting would be discovered in the shape of the tuyere and made public. During these epidemics tuyeres of almost every conceivable shape have been placed in cupolas, and great results in melting

claimed for them. Many of these tuyeres were soon found to be complicated and impracticable, or the advantage gained by their use in melting was more than offset by extravagant use of fuel.

It would be useless for us to describe all the tuyeres we have seen employed, for many of them were never used out of the foundry in which they were invented, and only used there for a short time. We shall, therefore, describe only a few of those that have been most extensively used or are in use at the present time.

The *round* tuyere is probably the oldest or first tuyere ever placed in a cupola. It was used in cupolas and blast furnaces in Colonial days in this country, and long before that in France and other countries. In the old-fashioned cast iron stove cupolas three round tuyeres were generally placed in a row, one above another, on opposite sides of the cupola. The first or lower tuyere was placed from 18 to 24 inches above the sand bottom, and the others directly over it from 3 to 4 inches apart. The tuyere nozzle or elbow was attached to the blast-pipe by a flexible leather hose, and first placed in the lower tuyere and the two upper tuyeres temporarily closed with clay. When a small heat was melted the nozzle was permitted to remain in the lower tuyere throughout the heat. But when a large heat was melted and the cupola melted poorly at any part of the heat, or if molten iron was to be collected in the cupola for a large casting, the clay was removed from the upper tuyeres, and the nozzle removed from one to the other, as required, and the lower tuyeres closed with clay.

In these cupolas the tuyeres were generally too small to admit a proper volume of blast to do good melting. In one of 28 inches diameter we recently saw at Jamestown, N. Y., the original tuyeres were only 3 inches in diameter. Two tuyeres of this size could not possibly admit a sufficient volume of blast to do good melting in a cupola of the above diameter, and in this one they had been replaced by two of a much larger diameter placed at a lower level than the old ones. The round

tuyere is still extensively used in small cupolas where the tuyeres can be made of a diameter not to exceed 5 or 6 inches, but in large cupolas it has generally been replaced by the flat or oval tuyere, which admits the same volume of blast and permits of a smaller amount of fuel being used in the bed than could be used with a round tuyere of large area.

OVAL TUYERE.

In Fig. 2 is shown the oval or oblong tuyere now extensively used. It is made of different sizes to suit the diameter of cupola, the most common sizes used being 2 x 6, 3 x 8, and 4 x 12 inches. They are laid flat in the lining and generally supplied from an outside belt air chamber. This tuyere is the one most commonly used by stove, bench and other foundries requiring very hot iron for their work. They are placed very low, generally not more than two or three inches above the sand bottom, and in large cupolas the slope of the bottom frequently brings it up to the bottom of the tuyeres on the back side of the cupola. This tuyere admits the blast to a cupola as freely as a rounded tuyere of the same area, and the tendency of the stock to chill over the tuyeres in settling and bridge the cupola is no greater than with a round tuyere of the same capacity. It admits of a lower bed than the round tuyere, and is to be preferred to the round form for cupolas requiring tuyeres of a larger area.

EXPANDED TUYERE.

In Fig. 3 is seen the expanded tuyere, which is made larger

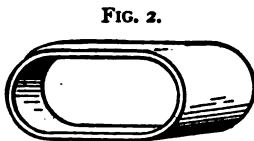

CUPOLA TUYERES—OVAL TUYERE.

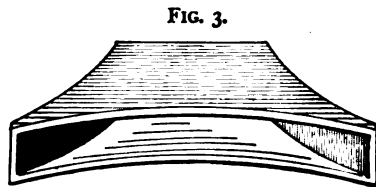

EXPANDED TUYERE.

at the outlet than at the inlet. It is reduced at the inlet so

that the combined tuyere area may correspond with the outlet of the blower and equalize the volume of blast entering the cupola at each tuyere from the air belt. It is expanded at the outlet to permit the blast to escape freely from the tuyeres into the cupola, and in case the stock settles in the front of the tuyere in such a way as to close up part of it, there may still be sufficient opening for the full volume of blast entering the tuyere to pass into the cupola. The tuyere is made from two to four inches wide at the inlet and six to twelve inches long. The width of the outlet is the same as that of the inlet, and the length of the outlet is from one-fourth to one-half longer than the inlet. The tuyere is laid flat in the lining, the same as the oval tuyere, and the only advantage claimed for it over that tuyere is that it cannot be closed so readily by the settling of the stock and the chilling of the iron or cinder in front of it. The expanded tuyere is preferred by many to the oval tuyere on this account and is extensively used at the present time.

DOHERTY TUYERE.

In Fig. 4 is seen the Doherty arrangement of tuyeres, designed by Mr. Doherty of the late firm of Bement & Doherty, Philadelphia, Pa., and employed in the Doherty cupola, a cupola that was extensively used in Philadelphia about twenty-five years ago. The arrangement consists of two or more round tuyeres placed in the lining and at an angle to it, instead of passing straight through the lining as tuyeres generally do. The blast pipes connecting with each tuyere were placed at the same angle as the tuyere, the object being to give the blast a whirling or spiral motion in the cupola. The blast took the desired course, as could be plainly seen by its action at the charging door, and it had the appearance of making a more intense heat in the cupola than when delivered from the straight tuyere. But this appearance was deceptive, and after careful investigation it was found that no saving in fuel was effected or faster or hotter melting done on account of this motion of the blast. The cupolas and tuyeres were, however, constructed of proper pro-

portions, and were a decided improvement on the small tuyere cupolas in use at that time. Many of them were placed in foundries and are still in use, but no importance is attached to the spiral motion of the blast.

SHEET BLAST TUYERE.

In Fig. 5 is seen the horizontal slot tuyere. This tuyere

FIG. 4.

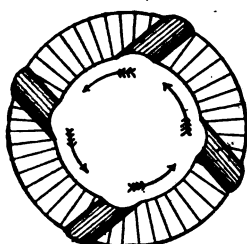

DOHERTY TUYERE.

FIG. 5.



SHEET BLAST TUYERE.

consists of a slot from one to two inches wide, extending one-third around the cupola on each side, or a continuous slot extending all the way around the cupola. The slot is formed by two cast iron plates, on one of which are cast separating bars to prevent the plates being pressed together by the weight of the lining or warped by the heat. This tuyere is known as the sheet blast tuyere. It admits of a smaller amount of fuel being used for a bed than any other tuyere placed in a cupola at the same height above the bottom. It distributes the blast equally to the stock, and does fast and economical melting in short heats. But the tendency of the cupola to bridge is greater than with almost any other tuyere, and a cupola with this tuyere cannot be run successfully for a greater length of time than two hours.

MACKENZIE TUYERE.

In Fig. 6 is seen the Mackenzie tuyere, designed by a Mr. Mackenzie of Newark, N. J., and used in the Mackenzie cupola. This is a continuous slot or sheet blast tuyere, but differs from the one just described in that the cupola is boshed and the bosh

overhangs the slot from four to six inches. The slot is protected by the overhanging bosh and cannot be closed up by the

FIG. 6.

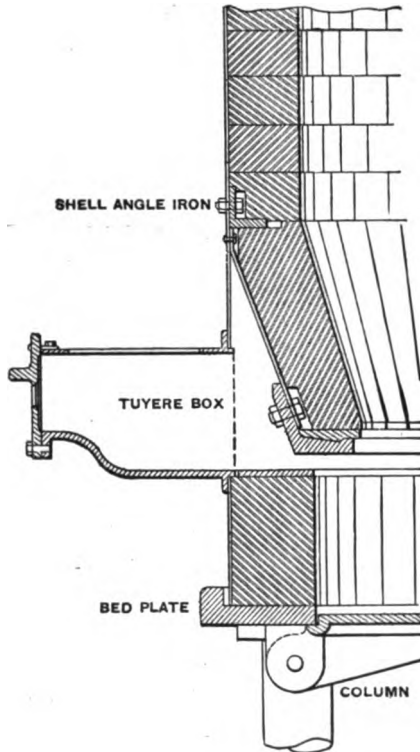

MACKENZIE TUYERE.

settling of the stock. The Mackenzie cupolas with this tuyere are constructed of an oval or oblong shape, with an inside belt air chamber. The blast enters the air chamber from a tuyere box at each end of the cupola, and passes into the cupola through a two-inch slot extending all the way round the cupola.

BLAKENEY TUYERE.

In Fig. 7 is seen the Blakeney tuyere used in the Blakeney cupola constructed by The M. Steel Company, Springfield, Ohio.

This tuyere is a modification or an improvement on the sheet blast tuyere, and extends all the way round the cupola. It is

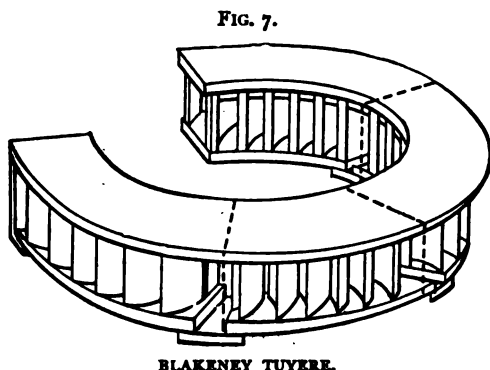

supplied from an outside belt air chamber riveted to the shell. The blast is conducted to the air chamber through one pipe, and, striking the blank spaces sidewise in rear of chamber, passes all around through the curved tuyeres into the centre of the furnace. This tuyere admits the blast freely and evenly to the cupola and very good melting is done with it. All the tuyeres described above may be used with either coal or coke.

HORIZONTAL AND VERTICAL SLOT TUYERE.

In Fig. 8 is seen the horizontal and vertical slot tuyere.

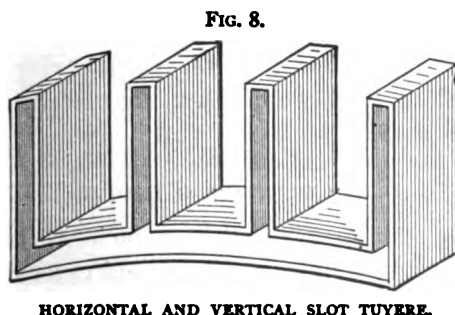

This was designed for coke, and we have seen it used in but one cupola, a 40-inch one. One tuyere was placed on each

side of the cupola. The horizontal slot of each tuyere, 1 inch wide, extended one-third way round the cupola, and the vertical slots, 1 inch wide and 12 inches long, were placed above it as shown. The tuyere did excellent melting, and the cupola could be run for a long time without bridging.

REVERSED T TUYERE.

In Fig. 9 is seen a vertical and horizontal slot or reversed T tuyere, also used for coke. The slots in this tuyere are from two to three inches wide and ten to twelve inches long. From two to eight of these tuyeres are placed in a cupola, according to the diameter. This tuyere has been extensively used, and is said to be an excellent tuyere for coke-melting.

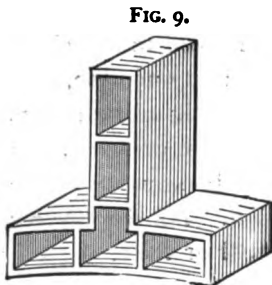

REVERSED T TUYERE.

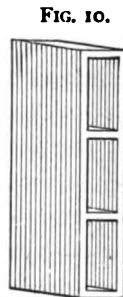

VERTICAL SLOT TUYERE.

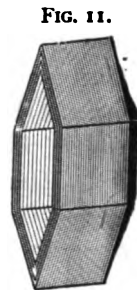

VERTICAL SLOT TUYERE.

In Figs. 10 and 11 are seen the vertical slot tuyeres used principally in cupolas of small diameter to prevent bridging. They are made from two to three inches wide and ten to twelve inches long, and two or more are placed in a cupola at equal distances apart.

TRUESDALE REDUCING TUYERE.

In Fig. 12 is seen the Truesdale reducing tuyere designed by Mr. Truesdale of Cincinnati, Ohio, and extensively used in cupolas in that vicinity about 1874. The tuyere consisted of one opening or tuyere placed directly over another until six, eight or ten tuyeres were put in. The lower tuyere was made

three or four inches in diameter, and tuyeres above it were placed one inch apart, and each one made of a smaller diam-

FIG. 12.

TRUESDALE REDUCING
TUYERE.

FIG. 13.

LAWRENCE REDUCING
TUYERE.

FIG. 14.

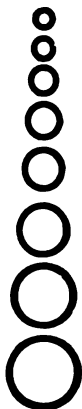
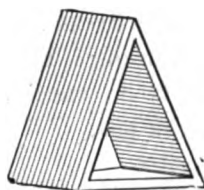

TRIANGULAR TUYERE.

eter until they were reduced to one inch. The bottom row of tuyeres were placed two, four or six inches apart, and the tuyeres in each succeeding row were placed further apart, were of a smaller diameter and admitted less blast to the cupola toward the top of the bed than at the bottom. The cupolas were generally boshed, and the tuyeres supplied from an inside belt air chamber, formed of cast iron staves, to which the tuyeres were attached by cleats or dovetails cast on the stays. Very fast melting was done in cupolas with this tuyere, but the tendency to bridge in cupolas of small diameter is so great that it could not be used in them. In large cupolas, however, it gave excellent results, and is still in use in numerous foundries.

LAWRENCE REDUCING TUYERE.

In Fig. 13 is seen the Lawrence reducing tuyere designed by Frank Lawrence of Philadelphia, Pa., and used in the Lawrence cupola, built by him. This tuyere was designed for either coal or coke melting, and works equally well with either. The

opening at the bottom is from 3 to 4 inches square, and the slot from 10 to 12 inches long, from 1 to $1\frac{1}{2}$ inches wide at the bottom, and tapers to a point at the top. The tuyeres are placed in the cupola from 6 to 12 inches apart, and supplied from a belt air chamber inside the casing. The air chamber in this cupola was first formed with cast iron staves, and the tuyeres held in place by cleats cast upon the staves. But the staves were found to break after repeated heating and cooling, and a boiler-iron casing is now used for the air chamber. This tuyere and cupola do excellent melting, and a great many of them are now in use.

TRIANGULAR TUYERE.

In Fig. 14 is seen the triangular tuyere, designed by the writer over 25 years ago to prevent bridging in small cupolas, and extensively used in both small and large cupolas, with either coal or coke. This tuyere may be made with the base and sides of equal length, forming an equilateral triangle, or the sides may be made longer than the base, bringing the tuyere up to a sharp point at the top to prevent bridging; or the sides may be extended up to a sufficient height to form a reducing tuyere.

The Magee Furnace Company, Boston, Mass., placed this tuyere in their large cupola, constructed to melt iron for stove plate, about fifteen years ago, and it has been in constant use ever since, giving excellent results in melting with coal and coke. In this cupola, which is 5 feet 4 inches diameter at the melting point, the tuyere is 9 inches wide at the base and 16 inches high. It was not thought best to extend the tuyere up to a point at so sharp an angle, and the top was cut off, leaving the opening 2 inches wide at the top. This tuyere has been arranged to take the place of the Truesdale reducing tuyere, and has been made from 6 to 8 inches wide at base and 24 to 30 inches high, running up to a point. It has also been used in imitation of the Lawrence reducing tuyere, and made from 3 to 4 inches wide at base and 12 to 16 inches high.

WATER TUYERE.

In Fig. 15 is seen the water tuyere. This tuyere is designed to be used in cupolas or furnaces where the whole or part of the tuyere is exposed to an intense heat and liable to be melted or injured, as is the case with tuyeres placed in the bottom of a cupola or in furnaces where a hot blast is used.

The tuyere or metal surrounding the tuyere opening is cast hollow and filled with water, or one end is left open and a spray thrown against the end exposed to the heat from a small pipe, as shown in illustration. The tuyere is also made with a coil

FIG. 15.

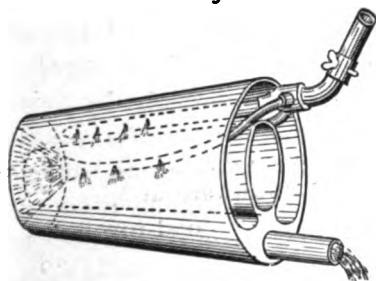

WATER TUYERE.

FIG. 16.

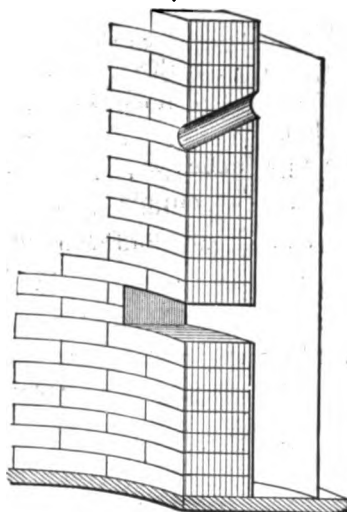

COLLIAU TUYERE.

of gas pipe cast inside of it, through which water constantly flows. The water tuyere is never used when the tuyeres are placed in the sides of the cupola, but it has been used in cupolas in which the tuyere was placed in the bottom and exposed to the heat of molten iron, cinder and slag. When used in this way the tuyere is placed in the centre of the bottom, and is made from 1 to 3 feet long, the mouth being placed at a sufficient height above the sand bottom to prevent molten

iron or slag overflowing into it. The part of the tuyere extending up in the cupola and exposed to the heat is protected and prevented from melting by the stream of water. For this purpose the coil gas pipe tuyere is better than the hollow or spray tuyere just described.

COLLIAU TUYERE.

In Fig. 16 is seen the Colliau double tuyere designed by the late Victor Colliau of Detroit, Mich., and used in the Colliau cupola. In this cupola the tuyeres are placed in two rows one above the other in place of one row as in the ordinary cupola. The first row is placed at about the same height above the sand bottom as in the ordinary cupola and the second row from 12 to 18 inches above the first row. The first row are flat, slightly expanded tuyeres similar to that shown in Fig. 3, and are made from 2 to 4 inches wide and 6 to 14 inches long, according to the size of the cupola. The tuyeres in the second row are made round and from 2 to 4 inches diameter. The tuyeres in the first row pass straight into the cupola through the lining, and those in the second row are pointed downward at a sharp angle, as shown in the cut. The object of the second row is to furnish sufficient oxygen to consume the escaping gases and create a more intense heat at the melting point than is obtained with the single row of tuyeres from the same amount of fuel.

WHITING TUYERE.

The Whiting tuyere, used in the Whiting cupola, manufactured by the Whiting Foundry Equipment Company, Chicago, Ill., was designed by Mr. Whiting, a practical foundryman of Detroit, Mich., as an improvement on the Colliau tuyere. The Whiting tuyere is a double tuyere, but differs somewhat in arrangement from the Colliau. The first row are flat, slightly expanded tuyeres, and the second row are of the same shape and made larger in proportion to the lower row than the Colliau, and the two rows are not placed at so great a distance apart. Both the upper and lower rows pass straight into the cupola.

CHENNEY TUYERE.

The Chenney tuyere, designed by the late Mr. Chenney, a practical foundryman of Pittsburgh, Pa., is a double tuyere very similar in arrangement to the Colliau and Whiting, the only difference being that both the upper and lower rows point downward at a sharp angle to the lining.

THE DOUBLE TUYERE.

The double or two rows of tuyeres appears to have first been designed and put into practical use about 1854 by Mr. Ireland, a practical English foundryman and cupola builder. In Ireland's cupolas, many of which were in use in England about that time, the tuyeres were placed in two rows about 18 inches apart. Those in the upper row were of only one-third the diameter of those in the lower, and twice the number of tuyeres were placed in the upper row as were in the lower. The slag hole was also used by Ireland in his cupola, which was run for a great many hours without dumping or raking out, as was the custom in those days. These cupolas appear to have given very good results in long heats, but in short heats they were not so satisfactory, and in more recent patents obtained by Mr. Ireland the upper row of tuyeres was abandoned. The double tuyere was also used in Voisin's cupola, another English cupola designer and constructor, and in Woodward's steam jet cupola, also an English cupola, many years before it was introduced into this country by Mr. Colliau about 1876.

It is claimed for the double tuyere that the second row consumes the gases which escape with the single tuyere, and, therefore, a great saving in fuel is effected in melting. That a more intense heat is created in the cupola at the melting zone by the double tuyere cannot be disputed, for the destruction of lining is much greater at this point than with the single tuyere; but on the other hand, that any saving in fuel is effected has not been proven by comparative tests made in melting with the double tuyere cupola and the single tuyere cupola, when

properly constructed and managed. On the contrary it has been proven that the single tuyere cupola is the most economical in fuel and lining. That the double tuyere melts iron faster than the single in cupolas of the same diameter is undisputed, and as between the single and double it is only a question whether the time saved in melting more than compensates for the extra expense of lining. When a double tuyere cupola is run to its full capacity, the consumption of fuel per ton of iron is about the same as the single tuyere, but in small heats it is much greater. This is due to the large amount of fuel required for a bed, owing to the great height of the upper tuyeres above the sand bottom; for the bed must be made about the same height above the upper tuyeres as above the lower in a single tuyere cupola, and no greater amount of iron can be charged on the bed with the double tuyere than with the single. When constructing or ordering a double tuyere cupola, the smallest one that will do the work should be selected, so that the cupola may be run to its fullest capacity each heat and the best results obtained in melting.

THREE ROWS OF TUYERES.

A number of large cupolas have been constructed with three rows of tuyeres, for the purpose of doing faster melting than can be done with the single or double tuyere cupola. Probably one of the best melting cupolas of this kind in use at the present time is one constructed by Abendroth Bros., Port Chester, N. Y., to melt iron for stove plate, sinks, soil pipe and plumbers' fittings. This cupola is 54 inches diameter at the tuyeres and 72 inches at the charging door, and is supplied with blast from 36 tuyeres, placed in the cupola in three horizontal rows 10 inches apart, 12 tuyeres being placed in each row. The tuyeres in the first row are 6 inches square, those in the second row 4 inches square, and those in the third row 2 inches square. This cupola melts 60 tons of iron in four hours, which is probably the fastest melting done in this country for the same number of hours for light work requiring hot iron.

In the double or triple tuyere cupola the upper tuyeres may be placed directly over a tuyere in the lower row, or they may be placed between the tuyeres of the lower row at a higher level. In Ireland's cupolas double the number of tuyeres were placed in the upper row than were in the lower row, so that one was placed directly over each tuyere in the lower row and one between. In the modern double tuyere cupola the same number of tuyeres are placed in each row, and the upper tuyeres are generally placed between those in the lower row. The object in placing these tuyeres in a cupola, as stated before, is to supply the oxygen to burn the unconsumed gases escaping from the combustion of fuel at the lower tuyeres. If a proper amount of blast is admitted at the lower tuyere the cupola is filled with gases at this point, and it does not make any difference whether the upper tuyeres are placed over or between the lower ones, so long as the tuyeres are only to supply oxygen to consume the gases with which the cupola is filled. If this theory of producing heat by consuming the escaping gases from the combustion of fuel is correct, they can be consumed at any point in the cupola, and the row of tuyeres for this purpose should be placed above the bed, and the gas burned in the first charge of iron to heat it and prepare it for melting before it settles into the melting zone. To consume these gases only, the tuyeres should be small, and the number of tuyeres in the upper rows should be two or three times greater than in the lower row, so as to supply oxygen to all parts of the cupola, and not permit the gases to escape unconsumed between the tuyeres. If the tuyeres in the second and third rows are made too large in proportion to the lower row, the supply of oxygen is too great for the combustion of the gases, and the effect is to cool the iron. In the modern double tuyere cupola this theory is not carried out, for the tuyeres in the second row are made big, and admit such a large volume of oxygen at one point that if they were placed high their effect would be to cool the iron rather than heat it. But they are placed low so as to force the blast into the bed and give a deeper melting

zone, and their effect is to cause a more rapid combustion of fuel and do faster melting than is done in the single tuyere cupola of the same diameter.

GREINER TUYERE.

In Fig. 17 is seen the Greiner tuyere. The novelty of this device consists in a judicious admission of blast into the upper zones of a cupola, whereby the combustible gases are consumed within the cupola and the heat utilized to pre-heat the descending charges, thereby effecting a saving in the fuel necessary to melt the iron when it reaches the melting zone. This device consists of a number of upright gas pipes attached to the top of the wind box around the cupola, with branch pipes of 1 inch diameter extending into the cupola through the lining and about 1 foot apart, from a short distance above the melting zone to near the charging door. It is claimed that these small pipes admit a sufficient amount of oxygen to the cupola to burn the carbonic oxide produced by the carbonic acid formed at the tuyeres absorbing carbon from the fuel in its ascent. A great saving in fuel is thus effected by consuming this gas and preparing the iron for melting before it reaches the melting zone. While, when the first edition of this book was published, quite a number of cupolas with this device were in use in this country, the Greiner theory of melting has now been practically abandoned, and we do not know of a single set of these tuyeres being in use at the present time.

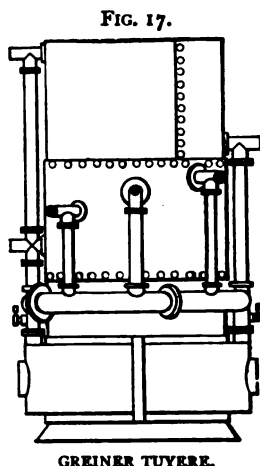

ADJUSTABLE TUYERES.

Tuyeres are sometimes placed in a cupola so that they may be adjusted to conform to the size of the heat to be melted or

the way the iron is to be drawn from the cupola, and thus save fuel in the bed. They are placed low when the heat is small or the iron is drawn from the cupola as fast as melted, and placed high when the heat is large or when iron is to be held in the cupola for a large piece of work. One of the best arranged cupolas of this kind we have seen is that of the Pennsylvania Diamond Drill & Mfg. Company, Birdsboro, Pa. The air belt extending around the cupola is riveted to the shell about 4 feet from the bottom plate. From this belt a cast iron air box bolted to the shell extends down nearly to the bottom plate in front of each tuyere. The front of this box has a sliding door extending full length of the box. The cupola shell has a slot in front of each box the full length of the box. On each side of this slot a piece of angle iron is riveted to the shell to hold the lining in place. The slot is filled in with fire-brick, and a tuyere opening is left at any desired height from the bottom. When it is desired to lower the tuyere the brick are removed from the bottom of the tuyere and placed at the top, and held in place by a little stiff daubing or clay, and when it is desired to raise it, the brick are removed from the top and placed at the bottom when making up the cupola. With the Colliau and Whiting style of air belt an adjustable tuyere can be arranged in this way at a very moderate cost, and foundry-men who think they must have their tuyeres placed high so they can make a large casting and only make such a casting once or twice a year, can save a great deal of fuel from the bed by having their tuyeres arranged in this way. The old plan of putting in two or three tuyere holes one above the other, and adjusting the tuyeres during the heat by raising the tuyere pipe from one to the other, is not practicable with the modern way of charging a cupola, and has long since been abandoned.

BOTTOM TUYERE.

In Fig. 18 is seen the bottom or center blast tuyere. This tuyere, as will be observed, passes up through the bottom of the cupola instead of through the sides, and admits the blast

to the center of the cupola at the same level as the side tuyeres. It is not designed to change the nature of the iron by forcing the blast through the molten iron in the bottom of the cupola, and, in fact, the blast has no more effect upon the quality of iron when admitted in this way than when admitted through side tuyeres. A tuyere when placed in the bottom of a cupola, unlike a side tuyere, is brought in direct contact with heated fuel and molten iron, and it must be made of a refractory material, or protected by a refractory material if

FIG. 18.

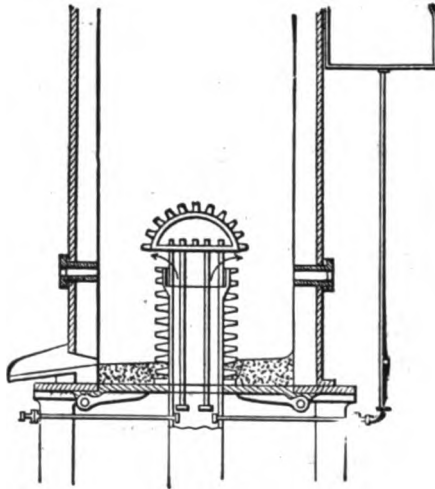

BOTTOM TUYERE.

made of metal. The tuyere shown in the cut is made of cast iron and is provided with a water space between the outside and the inside, through which a stream of water constantly flows, when the tuyere is in use, from a small pipe connected with a tank placed alongside the cupola or on the scaffold. But it has not been found necessary to keep the tuyere cool with water in short heats, for the heat in a cupola under the tuyeres is not sufficiently intense to melt cast iron, and the tuyere may be sufficiently protected against molten iron dropping upon it

or coming in contact with it by a thick daubing of refractory material held in place by the pricklers cast on the tuyere. The mouth of a bottom tuyere must be covered to prevent molten iron, slag and fuel dropping into it in their descent to the bottom of the cupola. This is done with a rounded cap placed on top of the tuyere to throw off the molten iron and slag, and the blast is admitted to the cupola through an opening around the tuyere under the cap, as indicated by the arrows. The tuyere must be carefully dried and daubed before it is put in place. It cannot be attached to the bottom doors and must be put in place through a hole in the doors after they are put up, and withdrawn in the same way and removed before the cupola is dumped, to prevent it being broken or injured in falling or by the heat in the dump. It must have an adjustable and removable support, and the sand bottom must be made up very carefully around it to prevent leakage of molten iron. The tuyere often gets fast in the bottom and the men are frequently burned in removing it, and it sometimes gets filled with iron or slag, and spoils a heat.

The bottom tuyere has been tried a great many times by foundrymen at different periods, and is nothing new. In conversing with several old foundrymen in Massachusetts about 20 years ago, we learned that the bottom tuyere had been used in that State away back in the 40's, and at one time was quite popular with foundrymen there; and we have met a number of other old foundrymen in different sections of the country who had tried the tuyere years ago and given it up. A bottom tuyere was patented by B. H. Hibler in this country August 13, 1867. Ireland and Voisin used a bottom tuyere in their cupolas many years ago, and had these practical men found any advantages in it over the side tuyere it would, no doubt, have been brought into general use in cupolas before this.

The bottom tuyere was brought prominently before the foundrymen of this country by an ably written article by Thomas D. West, read before the Western Foundrymen's Association at Chicago, Ill., October 18, 1893, in which he

describes his experiments with the tuyere and claims for it a great saving in fuel and cupola lining. Since the publication of Mr. West's article a number of foundrymen have published their experience with the tuyere and all claim it effects a great saving in lining and fuel. But if these foundrymen have not discovered some new feature in the tuyere that was overlooked by experimenters with it years ago, it will never come into general use.

Since the publication of the above in the first edition of this work, the bottom tuyere has been extensively tried by practical foundrymen and by cupola manufacturers who have constructed a variety of bottom tuyere devices, all of which were designed to obviate the difficulty of placing the tuyere in position, maintaining it there, removing it after a heat, and preventing molten iron and slag getting into the tuyere. So far as we have been able to learn all of these devices have been failures to so great an extent that the use of this tuyere has been practically abandoned, very few, if any of them are being used at the present time.

SIZE OF TUYERES.

Foundrymen make a great mistake in placing small tuyeres in their cupolas, with a view of putting the blast into the cupola with greater force and driving it to the center of the cupola with the blower. Air may be driven from a small opening by a blower with greater velocity than the same volume of air from a large opening, but the air from a small opening loses its velocity when it strikes a solid body, just the same as the air from a large opening. When the blast from a small tuyere strikes the solid fuel in front of it, its velocity is gone and it will not penetrate any further into the stock than the same volume of blast from a large tuyere. It is not the velocity at which the blast passes into a cupola that drives it to the center, but the force behind the blast. Neither is it the velocity of the blast that does the melting. It is the volume of blast. It therefore follows that nothing is gained in melting

by forcing the blast through a small tuyere into a cupola with great velocity, and much is lost by increasing the power required to run the blower to force the blast through a small tuyere.

The small tuyere was one of the greatest mistakes made in the old-fashioned stove cupola. In these cupolas, many of which we have seen, only two tuyeres of 3 or 4 inches diameter were placed in a 30-inch cupola, and the improvement made in melting in the modern cupola is largely due to the enlargement of the tuyeres and the free admission of blast to the cupola.

The combined tuyere area of a cupola should be equal to three times the area of the outlet of the blower when the blower is of a proper size for the cupola. These dimensions may at first sight seem large, but it must be remembered that the size or area of a tuyere when a cupola is not in blast does not represent the area of the tuyere when a cupola is in blast or the volume of blast that may be admitted to the cupola by the tuyere. When a cupola is in blast the space in front of the tuyere is filled with fuel weighted down by tons of iron. This fuel closes the mouth of the tuyere, and the outlet is represented by the number of crevices between the pieces of fuel through which the blast may escape. Should a large piece of fuel fall in front of a tuyere the blast cannot remove it and the tuyere may be closed and rendered useless. Small tuyeres are more liable to be closed in this way than large ones, and for this reason they should never be placed in a cupola. Small tuyeres, furthermore, are not only more liable to be stopped off by the fuel, but also tend to promote bridging by admitting an insufficient amount of blast at certain points.

HEIGHT OF TUYERE.

There is a wide difference of opinion among foundrymen as to the height or distance tuyeres should be placed in a cupola above the sand bottom. So great is this difference of opinion at the present time that tuyeres are placed in cupolas at from

2 inches to 5 feet above the sand bottom. This wide variation in the height of tuyeres is due to some extent to the different classes of work done in different foundries, it being claimed by foundrymen making heavy work that it is necessary to have the tuyeres high to hold molten iron in the cupola and keep it hot for a large casting. Foundrymen making light castings requiring very hot iron draw the iron as fast as melted, and do not think it necessary to have high tuyeres to hold iron in the cupola. In the many experiments we have made in melting iron in a cupola, we have placed the tuyeres at various distances above the sand bottom, and closely observed the effect of tuyeres at different heights. We learned by these experiments that the fuel under the tuyeres is not consumed in melting, nor is it wasted away to any extent by the heat or molten iron coming in contact with it. Charcoal may be placed in the bottom of a cupola, and if care is taken to prevent it being consumed by admission of air through the front before the blast is put on, the charcoal will not be consumed during the heat and may be found in the dump. We have tried this in our experiments to soften hard iron by bringing the molten metal in contact with charcoal in the bottom of a cupola, and found it correct. Pieces of charred wood used in lighting up are often found in the dump after having remained in the cupola throughout a heat. If these soft combustible substances are not consumed under the tuyeres, then it is not at all likely that the less combustible hard coal and coke are consumed. No iron can be melted in a cupola under the tuyeres, and the only function of the fuel below the tuyeres is to support the stock in a cupola above the tuyeres. If there is not sufficient heat in the bottom of a cupola to consume wood or charcoal, then there is not sufficient heat to keep molten iron hot for any length of time; and it is a well-known fact among practical foundrymen that large bodies of molten iron can be kept hot and fluid for a greater length of time in a ladle when covered with charcoal to exclude the air than they can be in a cupola.

Another reason given in favor of high tuyeres is that it is

necessary to have them high to tap slag in long heats. The only slag in a cupola that can be drawn through a slag hole is a light fluid slag that floats on top of the molten iron or rests on the bottom of the cupola when there is no molten iron in it, and this slag may be drawn at any point between the sand bottom and tuyeres. When a slag hole is placed high, slag only can be drawn when the cupola is permitted to fill up with molten iron and raise the slag upon its surface to the slag hole. Slag may then be drawn for a few minutes while the cupola is filling up with iron to the slag hole. As soon as the iron reaches the slag hole, however, it flows out and must be tapped from the front. The slag then falls in the cupola with the surface of the iron as it is drawn off, and the slag hole must be closed to prevent the escape of blast through it. Iron tapped after permitting a cupola to fill up to a high slag hole is always dull.

When a slag hole is placed low it is not necessary to have the cupola fill up with iron before slag can be tapped, for the slag may be drawn off the bottom of the cupola, and, furthermore, the slag hole may be opened and permitted to remain open throughout a heat without waste of blast. The flow of slag regulates itself when the hole is of proper size. It is, therefore, not necessary to place tuyeres high that slag may be drawn from a cupola, nor is it necessary to hold iron in a cupola for a large casting or to keep it hot. Molten iron should be handled in a ladle and not in a cupola.

Hot iron for light work cannot be made in cupolas with high tuyeres, and for this reason the tuyeres in stove-foundry cupolas are always placed low. In cupolas of large diameter, having a large bottom surface for molten iron, the tuyeres are placed so low that those at the back of the cupola are not more than 1 inch above the sand bottom, and those in front not more than 2 or $2\frac{1}{2}$ inches above the sand bottom. Tuyeres placed in this way give ample space below them to hold molten iron for this kind of work, for the iron must be very hot and is drawn from the cupola as fast as melted, and

the cupola is large enough to melt iron as fast as it can be handled, and it is only when the cupola is not working free that it is stopped up to accumulate iron. The tuyeres in any cupola may be placed as low as in these large ones, if provision be made for handling the iron as fast as melted.

In smaller cupolas not capable of melting iron sufficiently fast to fill a 40-pound hand-ladle, every 8 or 10 seconds the tuyeres are placed from 2 to 4 inches above the sand bottom, so that a sufficient quantity of iron may be collected before tapping to give each man in the section catching a hand-ladle full, and fill the ladle in about 6 seconds.

In cupolas of very small diameter the tuyeres should be placed from 6 to 10 inches above the sand bottom. These very small cupolas melt so slow that if the iron is drawn as fast as melted the stream is so small that the iron is chilled in flowing from the cupola to the ladle more than it is by holding it in the cupola until a body of iron is collected sufficient to supply a large stream.

In machine and jobbing foundry cupolas tuyeres are generally placed from 18 to 24 inches above the sand bottom. The object in placing the tuyeres so high is to hold iron in the cupola for a large casting. But, as before explained, this is not necessary or advisable. Another reason for these high tuyeres is that they are necessary for tapping slag. The slag from many cupolas is drawn off at the tap hole with the iron, and a number of spouts have been invented for separating the slag from the iron and preventing it running into the ladle. Slag may be drawn from the back of a cupola on a level with the sand bottom at that point, if the iron is drawn as fast as melted, or it may be drawn 1, 2 or more inches above the sand bottom at that point. It is, therefore, not necessary to place tuyeres at so great a height to tap slag.

The tuyeres in cupolas for heavy work should be placed from 6 to 8 inches above the sand bottom when slag is not to be tapped. This gives an abundance of room in a cupola for holding iron while removing or placing a large ladle, and that

is all that is necessary. The tuyeres in many of the cupolas used in Bessemer steel works are placed five feet above the bottom. They are probably placed at so great a height because the tuyeres in the first cupola constructed for this work were placed at that height. Tuyeres in all cupolas should be placed as low as they can be for the size of the cupola and facilities for handling the iron, for the fuel placed in a cupola under the tuyeres is not consumed in melting and is wasted by being heated in the cupola and crushed and burned in the dump. The value of fuel wasted every year in the United States by the use of high tuyeres in cupolas is sufficient to make a man rich.

NUMBER OF TUYERES.

A cupola may be supplied with blast from one tuyere placed on one side of the cupola, but the objection to one tuyere arranged in this way is that the heat is driven by the blast against the opposite side of the cupola, and the destruction of lining at this point is very great. For this reason, at least two tuyeres are always placed in a cupola, and they are located on opposite sides so that the blast will meet in the center and be diffused throughout the stock. When a greater number of tuyeres than two are placed in a cupola they are located opposite each other and at equal distances apart, to admit an equal amount of blast on all sides and prevent an uneven destruction of lining from the heat being forced unevenly against it by the blast. Any number of tuyeres desired may be placed in a cupola, and as high as 100 have been used in a 40-inch cupola, and a greater number in larger cupolas. But these large numbers have given no better results in melting than two or four tuyeres in the same cupolas. It is not necessary to place a large number of small tuyeres in a cupola to distribute the blast evenly to the bed, and it is not advisable to put in small tuyeres, which are easily closed by the fuel, cinder and iron, and are oftener rendered useless than large ones. Better results are obtained from large tuyeres and fewer of them.

The largest cupola in use may be supplied with blast by two tuyeres if they are big enough. The large cupola of the Buffalo School Furniture Company, Buffalo, N. Y., is supplied with blast by two tuyeres 12x18 inches, placed on opposite sides. This cupola, which is 60 inches in diameter inside, does excellent melting with only these two tuyeres, and the destruction of lining in melting is very light. We saw a large cupola with two tuyeres of about the above dimensions in use in a stove foundry in St. Louis, Mo., about 20 years ago, and it did excellent melting. The results obtained from these two cupolas would go to show that there is nothing gained in distributing the blast to the bed evenly by a large number of small tuyeres. When a number of tuyeres are placed in one row, every other tuyere is sometimes placed about the width of the tuyeres higher than the tuyeres on either side of it. We have, however, never observed that anything was gained in melting by placing tuyeres in this way. When a double row of tuyeres is used the upper row should be made very small in comparison with the lower row, for if they are made of the same size as the lower one, or even half the size, and the two rows are placed at any great distance apart, the heat is so concentrated upon the lining between them that it may be burned out to the casing in one or two heats. Foundrymen using the double tuyeres, who find the destruction of lining very great, may prevent it to some extent by reducing the size of the upper tuyeres.

SHAPE OF TUYERES.

The shape of a tuyere has nothing to do with the melting, except as it may tend to prevent bridging or increase the depth of the melting zone by supplying blast to the fuel at different heights in a cupola. A small horizontal slot tuyere extending around a cupola, or the greater part of the way around it, tends to promote bridging, and it is generally conceded that a cupola with a tuyere of this kind cannot be run for a greater length of time than two hours without bridging and clogging up. Vertical

slot and reducing tuyeres supply blast to the bed at different levels and increase the depth of the melting zone the same as the double tuyere. For this purpose the Truesdale, Lawrence and triangular tuyeres, with elongated sides, are excellent when made of a proper size and placed a proper distance apart. When it is not desired to admit the blast to the bed at different levels, the flat or oval tuyeres are generally considered the best shapes, for they admit the blast freely, and a less amount of fuel is required for a bed with these shapes than with a round or square tuyere of the same area.

TUYERES TO IMPROVE THE QUALITY OF IRON.

All kinds of fancy shaped tuyeres have been placed in cupolas to improve or change the quality of iron in melting. They have been placed to point up, point down, point across each other at certain angles, and to point to the center of the cupola. There is nothing more absurd than to attempt to improve the quality of iron in a cupola by the shape or angle of the tuyeres. The instant the blast leaves the mouth of a tuyere it strikes the fuel in front of it. The shape or angle given to it by the tuyere is then instantly changed, and it passes through the crevices in the fuel until its oxygen enters into combination with the carbon of the fuel and produces combustion. It then escapes at the top of the melting zone, where it comes in contact with the iron as carbonic acid gas. This is the result, no matter what the shape or angle of the tuyeres, if a proper amount of blast is supplied. It may be claimed that the blast acts upon the iron as it drops through the fuel in the bed after being melted; but as before stated, the shape or angle given to the blast by the tuyeres is changed by the fuel, and the effect on the iron of the blast from one tuyere would be the same as from another.

TUYERE BOXES.

The tuyeres may be and are often formed in the lining of a cupola when laying the brick, but this is a very poor way of

maying tuyeres, for there is nothing to support the brick and maintain the shape of the tuyeres, and they are often broken or burned away until there is no regular shape to the aperture, and it is difficult to put the blast into the cupola at the point desired or to prevent iron or slag getting into the tuyere. Tuyeres are more generally formed with a cast iron lining or tuyere box, having the shape and size of tuyere desired. This box may be cast with a flange on one end and be bolted to the casing, or it may be cast without a flange and placed in the lining at the desired point as it is laid up. The boxes are made in both ways, but it is better to cast them with a flange and bolt them to the casing, making an air-tight joint, as it then insures the blast going directly into the cupola at the point desired. Tuyere boxes laid in a lining answer the purpose very well when the lining is new, but when it becomes old and shaky, or a section is removed and replaced, the lining often settles and the grouting or filling falls out, leaving crevices through which the blast escapes between the casing and lining, and from there enters the cupola at points where it does no good.

The cold blast supplied to a cupola keeps the tuyere box cool, and it is not necessary to cast it hollow and fill it with water to prevent it being melted or injured by the heat. The only part of the box that is exposed and liable to be injured is the end next the fire, and to protect it the box at this point is generally cast about $\frac{1}{2}$ inch shorter than the thickness of the lining and the end covered with a little clay or daubing.

CHAPTER V.

CUPOLA MANAGEMENT.

THE peculiarities in the working of every cupola must be learned before it can be run successfully, and this can only be done by working it in different ways. It is a question very much disputed whether a cupola constructed upon the latest improved or patented design is superior to one of the old style. This question can only be decided by the intelligent working of each cupola, and the advantage will always be found in favor of the one that is properly worked, no matter what its construction. It is the duty of every foundryman to give his personal attention to the working of his cupola if he has time. If he is not a practical founder or has not the time to devote to this branch of the business that it requires, then he should have his foundry foreman give it his personal attention for a sufficient length of time each day to see that everything is right in and about the cupola.

No cupola can be run successfully by any given rule or set of rules, for conditions arise to which the rules do not apply. We shall therefore not only give directions for the proper working of a cupola at every point, but shall also give the results or effect of bad working at every point, so that the founder when he finds his cupola is not operating well may have some data from which to draw conclusions and be able to overcome the difficulty.

DRYING THE LINING.

The cupola having been newly lined, nothing is to be done to the lining for the first heat but to dry it. A very high or prolonged heat is not required for this when only one thick-

ness of brick is put in and laid up in thin grout. The lining may be dried by making a wood fire after the sand bottom is put in, or by starting the fire for the heat a little sooner than usual. But the fire must not be started too early or the bed will be burned too much and the cupola filled with ashes, which will retard the melting.

When a backing or filling of wet clay or sand several inches thick is put in between the casing and lining, more time and care are required in drying. It must then be dried slowly and evenly, or the filling will crack, and when jarred in chipping out will crumble and work out through cracks in the lining or holes in the casing and leave cavities behind the lining. When a lining is put in in this way, the doors are put up and covered with sand and a good coal or coke fire is made in the cupola and allowed to remain in over night. In the morning the bottom is dropped to remove the ashes and cool off the lining before making up the sand bottom for a heat.

. PUTTING UP THE DOORS.

The first thing to be done when making up the cupola for a heat is to put up the bottom doors. When the cupola is of small diameter and the door light it may be raised into place and supported by one man. But when the door is heavy two men are required, and if the cupola is a large one and the door made in two parts, three men are required to lift and support them. Two men get inside the cupola and raise one-half into place while the third man supports it with a temporary prop; they then raise the other half as far as it can be raised with their bodies between the two doors, where it is supported by a temporary prop. The men then get under the door on their hands and knees and raise it into place on their backs, and it is then supported by a prop.

Numerous devices have been arranged for raising the doors into place, but they soon get out of order from the heat of the dump or carelessness in manipulation, and they have almost all been abandoned. When the cupola is very small and the door

light, it is sometimes supported by an iron bolt attached to the under side of the bottom plate at the front, where it can be readily withdrawn with an iron hook to drop the bottom. But the doors are generally supported by a stout iron prop or post placed under the door near the edge opposite the hinges. Double doors are supported by a stout iron prop in the center and generally a light one at each end of the doors to prevent them springing when charging the fuel and iron, or by a sudden settling of the stock, as may occur when melting large chunks. A great many melters have no permanent foundation under the cupola upon which to place the main prop, but make one every heat by laying down a small plate upon the sand and setting the prop upon it. The plate is often placed too high or too low, making the prop too long or too short, and the plate must be raised by putting a little more sand under it or lowered by scraping away a little sand. While this is being done the heavy iron prop, which frequently requires two men to handle in the cramped position in which they are placed under the cupola, has often to be put up and taken down two or three times before it is gotten into the right position to support the doors.

All this extra labor can be avoided and time saved by imbedding a heavy cast iron block in the floor or foundation under the cupola for the prop to rest upon. It must extend down a sufficient distance to insure its not being disturbed when shoveling out the dump. A block 6 inches square and 10 inches long, placed with the end level with the floor, will seldom be displaced, and makes a sure foundation for the prop. The size of prop required to support a bottom depends upon the size of cupola. In small cupolas the stock is supported to a large extent by pressure against the lining, while in large cupolas the stock is supported almost entirely by the prop. For small cupolas the props are made from $1\frac{1}{2}$ to 2 inches diameter, and for large cupolas from 3 to $3\frac{1}{2}$ inches diameter.

The props for large cupolas not only have a greater weight to support, but they are seldom pulled out of the dump and

are therefore, if light, liable to be bent and twisted to such an extent as to render them useless. For this reason they are often made heavier than is actually necessary for the support of the bottom. Quite a number of foundrymen have adopted the plan of attaching a ring to the prop near the top or bottom with which to draw it from the dump and avoid heating it. The ring is made large and hangs loosely, or as a long loop which stands out from the prop. When the prop is to be removed a hook is placed in the ring or loop and a quick jerk given, which releases it, and it is at once drawn from under the cupola.

Some of the older melters never use the iron prop, but measure and cut a new wood prop for their cupola every heat. Many of them are so superstitious that they think the cupola would not melt without the new prop, and they would rather give up their jobs than try it. Such melters are not so plentiful now as they were 30 years ago, when we first began traveling as a melter through this country and Canada, but we find when visiting foundries there are still a few of them left.

DROPPING THE DOORS.

When it is desired to drop the doors it is done by removing the props or drawing the bolt. The small props are first taken out, being released by a stroke of the hammer, and are carefully laid away so that they will not be bent by the heat of the dump. A long bar with a handle on one end and a large hook on the other is then placed under the cupola with the hook behind the main prop and about 10 or 12 inches from it. By a sudden jerk of the bar the hook is made to strike the bottom of the prop a sufficiently hard blow to knock it out of place and permit the door or doors to drop. Two or more blows of the bar are sometimes necessary to release the prop, but it can always be released in this way. It can also be released by striking it at the top with a straight bar, but it is oftener missed than hit, and many thrusts are sometimes required to bring it down. Bolts are only used on small cupolas from

which the dump falls slowly, and the bolt can generally be withdrawn by a blow of the hammer without danger to the melter. If it cannot be withdrawn in this way without danger of burning the melter, a hook is made on the end of the bolt or a ring placed in it so that it may be drawn with a hooked bar or struck with a long straight bar.

SAND BOTTOM.

When the door or doors are in place and properly supported, any openings or holes that may have been burned through them are carefully covered with a thin plate of iron, and all cracks through which the bottom sand might escape when dry are closed with clay. The doors are then covered with a bed of sand several inches in thickness, which is known as the sand bottom. The sand employed for this purpose must not be of a quality that will burn away and permit the molten iron to get down to the doors, or melt and form a hard mass that will not fall from the cupola when the doors are dropped, neither must it be so friable as to permit the molten iron to run through it when dry.

The clay sands when used for a bottom burn into a hard, tough mass that adheres to the lining all around the cupola, and in a small cupola frequently remains in place after the door is dropped and has to be dug out with a bar before the cupola can be dumped. Parting sand, sharp and fire sands are very friable and difficult to keep in place. They do not resist the action of the molten iron well, but melt and form a slag. Mixtures of clay and sharp sand burn too hard and do not drop well. The loam sands are the only ones suitable for a sand bottom, and sand that has been burned to a limited extent makes a better bottom than new sand.

In stove and other foundries with large gangway floors the scrapings from the gangways are collected in front of the cupola, passed through a No. 2 riddle to recover the scrap iron, and the sand used for the cupola bottom. This sand makes the very best kind of bottom. It is clean and free from

cinder, soft and pliable, packs close, resists the action of the molten iron and drops free. In foundries where the daily gangway cleanings are not sufficient to make the bottom, part of the old bottom is used over and the gangway cleanings are mixed with it or placed on top. In foundries where there are no regular gangways to clean every day, the heavy part of the dump is thrown out and the sand bottom passed through a No. 2 riddle and used over again. When the bottom sand is used over day after day it must not be riddled out too close, and a little fresh material must be added to it each day to prevent it from becoming rotten from repeated burnings and containing too many small particles of cinder, which render it fusible and easily cut away by the molten iron. The cleanings from the moulding floors are generally added or a few shovels from the sand heaps, and in case it becomes too rotten a few shovels of new moulding sand are mixed with it.

When the material contains so much cinder that it does not make a smooth bottom, a few shovels of burned sand from the heaps are put on to give an even surface and prevent the molten iron coming in contact with the cinder and cutting the bottom. The bottom sand is generally wet with water, but some melters wet it with clay wash, to make it more adhesive and give it more strength to resist the action of the molten iron. A thick clay wash gives strength to a rotten sand when mixed with it, but it also increases the tendency of the bottom to cake and hang up, and it is better to improve the bottom material in the way above described and wet it with water only. The sand when wet is cut over and evenly tempered, and should be no wetter than moulding sand when tempered for a mould.

The sand may be thrown into the cupola through the front opening, or may be thrown in at the charging door, but it is generally thrown in at the front, for it is more convenient to the material, and is also convenient for spreading it in the cupola. When the cupola is small the melter stands by the side of it and makes up the bottom by passing his arm in

through the front opening; but when the cupola is large he goes inside, and his helper shovels the sand in as he wants it. The first sand thrown in, is carefully packed around the edges with the hands to insure a tight joint. As the balance of the sand is thrown in, it is spread evenly over the bottom in layers from 1 to 2 inches thick, and each layer is evenly rammed or trampled down until the required thickness of bottom is obtained, which is from 3 to 6 inches, according to the rise of the cupola. The desired pitch or slope for throwing the iron to the front is then given, and the bottom butted evenly and smoothly all over. The melter next goes carefully around the edges with his hands and feels for any soft spots there may be near the lining, and slightly raises the edges of the bottom around the lining to throw the iron off and prevent it working its way down between the lining and sand bottom. The bottom is then carefully brushed and smoothed off, and in small cupolas a bucket of thin clay wash is sometimes thrown in at the front and caught in the bucket as it runs out. This is called slushing the bottom, and is done to give a smooth, hard surface.

The sand bottom does not always remain impervious to the molten metal, but is sometimes penetrated or cut up and destroyed by it, in which case a leakage of molten iron takes place from the bottom of the cupola that is difficult to stop. Leakage of this kind may be due to springing of the bottom doors when charging and the cracking or loosening of the sand bottom around the lining. This can be prevented by placing more props under the doors to support them. Sand that has been used over and over in a bottom until it has become worn out and filled with cinder is readily cut up and converted into a slag by the molten iron, and it is only a question of the time occupied in running off the heat whether the bottom gives way or stands. When the bottom sand gets into this condition, it must be renewed by the addition of new sand, or the bottom covered with a layer of sand from the moulders' sand heaps.

Molten iron will not lie upon a wet, hard substance, but will explode or boil and cut up the material upon which it is placed. If the bottom sand is made too wet, or rammed too hard, or rammed unevenly, the iron will not lie upon it, but will boil and cut up the sand until it gets down to the doors, which it will melt and run through. When a bottom cuts through, melters frequently attribute it to the bottom being too soft; and we have seen them take a heavy pounder and ram a bottom as hard as a stone. In these cases, if the sand was worked very dry, or the bottom was well dried out before any molten iron came in contact with it, it did not cut up or leak; but if the sand was wet when the molten iron came down, boiling at once took place and the bottom soon cut through—and in such cases they generally cut through about every other day. In the sand bottom of a cupola we have the same elements to contend with, so far as molten iron is concerned, as we have in a mould; and the sand should be worked no wetter, rammed no harder, and rammed as evenly as the sand for a mold. The sand should not be worked wet for a bottom, under the impression that it is dried out before the iron comes down, for the ashes of the shavings, wood, coal or coke cover the bottom soon after the fire is started, and protect it from the heat to such an extent that it is only dried to a very limited degree before the iron comes down upon it. Water may be seen dripping from a very wet bottom long after the blast is on. Even if it were dried out, wet sand cracks when dried rapidly and should not be used. We shall not attempt to give any directions for stopping a leak after it occurs, for the time and place to stop a leak is when putting in the sand bottom; and if all the remedies we have given for preventing leaks fail, then it is time to change the melter.

The pitch or slope given to the bottom to cause the molten iron to flow to the tap hole from all parts of the bottom has a great deal to do with the temperature of the iron and nice working of a cupola. When the bottom is made too low and flat, molten iron lies in the bottom of the cupola and becomes

dull. As the melted iron falls into this iron drop by drop, it is instantly chilled and the iron when drawn from the cupola is dull. This effect is more marked in a cupola melting very slowly, and a low bottom may be the cause of very dull iron when a sufficient quantity of fuel is consumed to make very hot iron. A high pitch throws the iron from the tap hole with great force and spouting velocity, and it is almost impossible to run a continuous stream from a cupola with such a bottom. It is more difficult to keep the tap hole and spout in order, and the stream must be closely watched to prevent it shooting over the ladle and burning the men. Slag flows freely from the tap hole with the stream of iron when the bottom has a high pitch, even when there is very little slag in the cupola. But the flow of slag from the tap hole with the iron may be entirely stopped by changing the pitch of the bottom, no matter how great the quantity of slag in the cupola. The action of the iron at the spout is entirely changed by the pitch of the bottom. A hard iron may be made to run smooth from the spout, while a soft iron may be made to sparkle and fly, giving all the indications of a hard iron. The best expert on the quality of iron at the spout may be deceived in the iron by the pitch of the bottom, and it is only in the extremely hard and extremely soft irons they cannot be deceived. The bottom should never be made hollow in the center and high all around the outside with an outlet or trough to the spout. This concentrates the iron in the center in such a way that a few hundred weights places as great a pressure upon the front as a ton would do if the bottom were flat, and the front may therefore be forced out by a comparatively small body of iron. The instant the tap hole is open the iron rushes out with great force, and it is almost impossible to stop it as long as there is any molten iron in the cupola.

The bottom should be made flat and level from side to side with only a slight rise around the lining, which should not extend out more than 1 or 2 inches from the lining. The pitch from back to front should not be more than $\frac{1}{2}$ to $\frac{3}{4}$ inch to the foot. This has been found to be a sufficient slope to throw

all the iron to the front in an ordinary cupola. But in cupolas that melt very slowly a little more slope may be given, so as to concentrate the iron more rapidly and prevent it chilling on the bottom.

In cupolas with two tap holes the bottom must be sloped so that all the melted iron in the cupola can be drawn from either tap hole. It is very difficult for a melter to see what slope he is giving a bottom when inside the cupola, and for this reason many of them seldom get the slope two days alike. The melter should be provided with a notched stick or some other gauge, for measuring down from the top or bottom of each tuyere, to serve as a guide in sloping the bottom, so that it may be given the proper pitch and put in alike every heat.

SPOUT.

The old way of making a cupola spout is to place a short piece of pig iron on the bottom plate on each side of the front, and build up a spout between them with clay or loam. The modern spouts are made of cast iron with a flat or eight-square bottom, and are from 4 to 6 inches deep, 7 to 10 inches wide and 1 to 10 feet long. They are given a fall from the cupola of about 1 inch to the lineal foot, and are lined with a refractory material to protect them from the molten iron. The spout lining is made of a different material from the sand bottom, and generally consists of molding sand, loam or a mixture of fire clay and sharp sand. Some of the molding sands make an excellent spout lining that is not cut or fused by the stream of molten iron, while others crumble and break up too readily when cleaning the spout of dross and dirt, and cannot be used for this purpose. When a molding sand can be used it makes a nice clean spout that is easily and quickly made up. It is readily dried, and when making up the spout the crust of the old lining can be removed with a bar, and the sand wet up and used over with a coating of sand without removing it from the spout. For long spouts, requiring a good deal of material to line them, molding sand is the most economical material that can be used.

Some of the loam and blue clays make excellent spout linings alone or when mixed with sand, and are the only materials used for this purpose in some sections of the country where they can be procured at a moderate cost. They make a stronger lining than molding sand—that is, not so liable to be broken up when cleaning the spout of dross and slag—and, furthermore, they dry quickly. The lining material probably more extensively used than any other is a mixture of fire clay and sharp sand. These two refractory substances when combined in right proportions and thoroughly mixed make one of the very best spout linings. But when not properly mixed they make one of the poorest linings.

When too much clay is used the lining does not give up the water of combination until heated to a very high heat, and it is almost impossible to get the lining dry so that the iron will not boil in the spout the first few taps, when the spout is long, or sputter and fly when it is short. It cracks when dried rapidly, and is melted into a tough slag that bungs up the spout and cannot be removed without destroying the lining. When too much sand is used the lining crumbles when touched with the bar and is cut and melted by the stream. When the clay and sand are not thoroughly mixed the lining crumbles and cuts or melts in spots. A spout lining made of these two materials in right proportions, properly mixed and dried, becomes as refractory as a fire-brick, and 50 or 100 tons of iron may be run from a spout lined with them without a break in the lining. There are a number of other materials used for spout linings that are only found in certain localities, and their use is restricted to the districts where they can be procured at a moderate cost. But those above described are the materials most commonly used for this purpose.

The spout lining is made up new every heat, and when putting it in the spout is wet to make it adhere to it. The sand bottom is cut away from the front and the spout lining made to extend into the cupola past the tap hole. A perfect joint is made between the sand bottom and spout lining, and a

little clay wash is generally brushed over the joint to make it more perfect and prevent cutting. Care must be taken to not get the bottom of the spout at the tap hole higher than the sand bottom, and also to give it the same pitch as the sand bottom. The bottom is put in first and is made about 1 inch thick when the spout has been given the proper pitch. If the spout has not been given a proper pitch, the lining is made heavier at the end next the cupola and light at the outer end, and the pitch given in the lining. This is the common practice in short spouts.

The sides of the lining are built up full at the bottom, so as to leave only a narrow groove in the middle and keep the stream always in one place, but are sloped back from the middle to the top of the spout to give a broad spout surface for carrying the stream of iron. A half round groove 1 inch deep and 2 inches wide at the top is sufficient to carry off the stream of iron from almost any cupola. But the spout is liable to be choked up by dirt from the tap hole or slag, and it is made larger for safety. A rammer is seldom used in making up a spout and it is generally made up with the hands and one of the bod sticks, or the small round stick used to make the tap hole.

When molding sand is used it is worked a little wetter than for molding and is beaten down with the bod stick and shaped up with the hands and bod stick. When clay or a mixture of clay and sand is used, it is worked wet and placed in the spout in balls and beaten or pressed into shape with the hands, and the bod stick is used to true it up and form the groove in the middle. Short spouts are made up with but little difficulty, but great care must be taken in making up a long spout to have it perfectly true and properly pitched, so that it will clean itself of molten iron the moment the cupola is stopped in.

The greatest strain upon the spout lining is under and around the tap hole, where it is liable to be cut away by the pressure and current of the stream or to be melted if the material is not very refractory, and it may be broken up by

the tap bar if not very tenacious when heated to a high temperature. When molding sand or other materials that do not stand a high temperature well or are not very tenacious when heated are used, a layer of fire clay and sharp sand is placed over the lining material under the tap hole. When the heat is very heavy and a large amount of iron is drawn from one tap hole, a split fire brick is embedded under the tap hole to prevent cutting and insure a good tap hole throughout the heat. The spout is seldom coated or painted with blacking after it is made up or dried, but when a friable material is used for lining it is sometimes coated with clay wash.

If the spout is made with a broad, flat bottom the stream takes a new course every time the cupola is tapped, and before the heat is over the spout is so bunged up that the iron collects in pools. A continuous stream cannot, therefore, be maintained the length of the spout, and two or more streams may fall from the end of the spout at the same time. To prevent this, shape the lining to form a small groove for the stream in the center and keep it there every tap. The quality of the lining material has a great deal to do with the condition of a spout during the running out of a heat. The spout may be cut out in holes by the stream, and pools of iron form in the spout at every tap. This is due to the lining material crumbling and being washed away by the stream. When this does not occur every heat with the same material, it is due to the material not being properly mixed; but if it does occur every heat, it is due to poor material. The spout may become choked or bunged up with slag when no slag flows from the tap hole with the iron. This is due to the lining melting and forming a slag. It is very difficult to keep a spout in order through a long heat when this occurs, and the lining material should at once be changed. Slag should be removed from the spout when very hot by lifting it up with a bar, or chipped away with a sharp bar when quite cold. All attempts to remove a tough semi-fluid slag break up and destroy the lining.

FRONT.

The front opening of the modern drop bottom cupola is made so small that it is not necessary to place an apron or breast plate over it to hold the front or breast in place, as is done with the draw-front cupola. The material used for putting in the front is generally the same as is used in making up the spout. The front is generally put in after the fire has burned up, but some melters put in the front before lighting, and light from the tuyeres. Others make up the tap hole and half the front with a stiff mixture of fire clay and sharp sand before lighting up, and fill in the other half after the fire has burned up. But as a general rule the entire front is left open to give draft for lighting, and the front is put in after the fire is burned up and about ready for charging. This gives sufficient time for drying it before the blast is put on.

When about to put in the front the ashes and dust are carefully brushed from the spout where the front is to be made, and the spout and front opening are wet all around with water or clay wash to make the front material adhere and insure a good joint. A breast of small pieces of coke is built in front of the fire, or a small board cut to fit the front, with a notch in the bottom for the tap hole, is placed in front of the fire to prevent the front material from being rammed or pressed too far back into the cupola. A small iron bar or a round wooden stick is then laid in the bottom of the spout to form the tap hole.

If the front is made of molding sand or other material that is likely to crumble at the tap hole and be cut away by the stream of iron or be broken away by the tap bar, a little fire clay and sharp sand, or other refractory material, is placed around the bar or stick to form the tap hole. The front material of molding sand or loam is then thrown in and rammed solid against the board, sides, top and bottom of the opening. If the front is made of clay or sand, and worked wet, it is made into balls and pressed into place with the hands. When the opening has been filled the front is cut away downward and inward from

the top and sides of the opening to the bar forming the tap hole, until the tap hole is not more than $1\frac{1}{2}$ inches long. The surplus material from the front is then removed from the spout, the bar drawn from tap hole and the front and spout carefully trimmed up.

If the spout lining and front have been made up with clay and sand, or other wet material, a wood fire is built on the spout to dry it and the front. When the spout and front are made up with molding sand or loam they are generally dried by the flame from the tap hole before stopping in, and an iron plate is sometimes laid on top of the spout to concentrate the heat upon it.

The front is generally made the full thickness of the lining and cannot be forced out by the pressure of molten iron if properly put in. When the front material is worked too wet, it falls away from the opening at the top when drying, and the opening must be closed to prevent the escape of the blast. If the tap hole is made too long the iron may chill in it, and the cupola cannot be tapped without cutting a new hole. This makes very bad work, for the iron is generally melted from the old tap hole by the stream passing through the new one, and the two holes become one. It is then very difficult to stop in or control the flow of iron.

When the front material is poor it melts into a semi-fluid slag that settles down and closes up the tap hole with a tough adherent slag that is difficult to remove. When this occurs, the tap hole can only be kept open by continually opening it up with a tap bar. The only way to overcome this difficulty is to use a more refractory front material. Mineral fluxes sometimes make a front material fusible that is not otherwise fusible. When trouble is experienced in keeping the tap hole open when using a flux, or after one flux has been substituted for another, the composition of the front material must be changed or another material used.

When no board is used and the front material is rammed back into the fire until it becomes solid in the front, the front

is ragged and soft on the inside and melts and makes a bad tap hole even when the material is good. A good front or spout lining can always be made from fire clay and sharp sand by mixing them in right proportions for the purpose for which they are to be used.

SIZES OF TAP HOLES.

The sizes tap holes are made depend upon how the iron is to be drawn from the cupola. If it is desired to run a continuous stream from the cupola, the tap hole is made small to suit the melting capacity of the cupola. If it is desired to accumulate a large body of iron in the cupola and fill a large ladle rapidly when the cupola is tapped, the hole is made large. The tap holes are made of various sizes from $\frac{5}{8}$ inch to $1\frac{1}{4}$ inches diameter, to suit the different kinds of work. When it is desired to run a continuous stream it is very desirable that the tap hole should not be cut and enlarged by the stream. This is generally prevented by placing a very refractory material around the rod forming the tap hole. But some melters have a form in which they mould a tap hole from a carefully prepared material that will not cut, and dry it in an oven or on a stove. This tap hole form, when thoroughly dried, is placed in position on a split fire-brick and the front made up around it, which always insures a regular sized hole throughout the heat.

LOCATING THE TAP HOLES.

We have already described the manner of putting in the front and forming the tap hole, and shall here only consider the location and number of tap holes. The tap hole is placed in the side of the cupola from which it is most convenient to convey the iron to the work to be poured, and it makes no difference in the working of the cupola upon which side it is placed if the bottom is sloped to throw the iron to the hole. One tap hole is sufficient to run the iron from any ordinary cupola, but two are frequently put in. In some cupolas two fronts and tap holes

are put in side by side only a few inches apart, and two spouts are made up so that the tap hole can be kept in better order for drawing off the iron. They are tapped turn about, and in case too great a quantity of melted iron accumulates in the cupola they are both opened at one time. Two tap holes placed in this way can only be worked for hand ladle work at the same time, and they cannot be worked to advantage even for that, for they are so close together the men are in each other's way. One tap hole if properly made and managed will run off all the iron a cupola will melt, and it is poor cupola practice to put in two fronts and tap holes in this way.

Two tap holes are frequently placed in a cupola for convenience in carrying the iron from the cupola to the molding floors. They are generally placed on opposite sides of the cupola, to save carrying the iron around the cupola or from one molding room to another. Two tap holes are also placed in cupolas to facilitate the removal of the iron in hand ladles. Six 40-pound hand ladles are all that can be safely taken from a spout per minute. When more than this number of ladles are filled and removed per minute, the men have to move so rapidly there is danger of a clashing of ladles and spilling of iron, and when a heavy stream once gets away from the men and falls to the floor, it spatters and flies so that it is difficult to stop in or again catch it. When more than 8 tons are melted per hour in a cupola for hand ladle work, two tap holes are always put in. They are placed in the side of the cupola that is nearest the work to be poured, but always at a sufficient distance apart to admit of the men catching at one spout being out of the way of those catching at the other.

SLAG HOLE.

A slag hole for drawing off slag is sometimes placed in a cupola, but it is not used except when the cupola is run beyond the capacity to which it can be run successfully without slagging. The hole is placed below the level of the tuyeres, and when it is desired to accumulate a large body of molten

iron in a cupola the slag hole is placed high. When the iron is drawn from a cupola as fast as melted the hole is placed low. The opening through the casing and lining is generally made oval and about 3 x 4 x 5 inches.

The slag hole front when the hole is placed high consists of a plug of the same material used for the tap hole front. The plug is placed in the outer end of the opening and is from 2 to 3 inches thick. A hole 1 inch diameter is made through it for a tap hole, and the plug or front is cut away from the edges of the casing to the hole until the hole is not more than $1\frac{1}{2}$ inches long. When the hole is placed low and the slag permitted to flow throughout the heat after it is opened, the plug is made of loam or molding sand mixed with a little blacking to make it porous when heated, and the plug is placed in the hole on the inside, flush with the lining. No tap hole is made through the plug when placed in this way, and when it is desired to tap slag a hole is cut through it with a sharp pointed tap bar. This material does not bake hard, and the entire plug may be cut out when necessary.

Slag chills more rapidly in a tap hole than iron, and is more difficult to tap or draw from a cupola, and when the slag hole is not properly arranged it cannot be drawn at all. If the tap hole is made small and long the slag chills in the hole and it is difficult to open the hole or keep it open. When the lining is very thick it must be cut away and the hole made large inside of the front, or the slag will chill in the lining the same as it might in the hole in the front. The hole in the lining can be made 6 or 8 inches diameter without injuring the lining, and a hole of this size will admit a sufficient quantity of slag to the tap hole to prevent it chilling. There is never any difficulty from the slag chilling when the front and tap hole are placed flush with the inside of the lining, for the slag is kept hot and fluid in the cupola, and may be drawn off whenever there is a sufficient quantity in the cupola to flow from it. It is therefore better to cut away the casing and lining, and place the front flush with the inside of the lining.

LIGHTING UP.

When the cupola is small the shavings are thrown in from the charging door and evenly distributed over the bottom. The wood is cut short and split fine and dropped down, a few pieces at a time, and so placed that the fire will burn up evenly and quickly. When the cupola is large the melter goes down into it and his helper passes him down the shavings and wood from the charging door. The shavings are evenly spread over the bottom, care being taken to get plenty around the outside to insure a good light. A layer of fine, light dry wood is then laid over the shavings, and on this a layer of heavier wood, and so on until the required quantity of wood for lighting the bed is placed in the cupola. Care is taken to arrange the wood so that it will burn up evenly and quickly. A light dry wood should be used, and the pieces must not be very large, or too much time will be consumed in burning them, and the bed will settle unevenly.

When the wood has been arranged the melter gets out and a thin layer of small coal or coke is placed over the wood. The bed fuel is then thrown in evenly over the wood. All the bed is put in but a few shovelfuls, which are kept to fill up any holes that may be formed by an uneven settling. The charging door is then closed and the shavings lighted at the front opening. The tuyere doors are opened to give draft and the fire left to burn up. When the wood is nearly burned out and there is a good fire of hot coals at the front and tuyeres, the melter generally puts in the front and spout and builds a wood fire on the spout to dry them. He then looks in at the charging door, and if the smoke is burned off and the fire beginning to show through the top of the bed, he puts in the remaining few shovels of fuel and makes the top of the bed as level as possible. He then closes all the tuyere doors but one and begins charging the iron into the cupola.

Straw may be used in place of shavings for lighting up when shavings cannot be procured. The wood should be dry pine or other light wood, and it must not be used in too large sticks

or the bed will be burned too much before the wood is burned out; and if the iron is charged before the wood is burned out, it smokes and the melter cannot see how to place the iron or fuel. For the same reason, hard or green wood should not be used in lighting up.

When the bed burns up on one side and not on the other in a small cupola, the bed may be burned up on the other side after the blast is put on and the heat run off successfully. But when the bed burns up on one side and not on the other in a large cupola the bottom had better be dropped at once. We once had to drop the bottom of a 60-inch cupola before the heat was half off, for the reason that the melter was careless in arranging the wood and lighting up, and charged the iron with the bed only burned up on one side. He thought the blast would make it burn up on the other side, but it did not, and the heat was a failure. Never burn the bed up to warm or heat up the cupola, for a cupola does not require to be heated before it is charged, and the lining burns out fast enough without wasting fuel to burn it out.

THE BED.

Iron is melted in a cupola within a limited space, known as the melting point or melting zone. The melting point is the highest point in a cupola at which iron is melted properly, and the melting zone is the space between the highest and lowest point at which iron melts properly. Iron may be melted to a limited extent above or below these two points, but it is burned, hardened and generally dull. The melting zone extends across the cupola above the tuyeres, and is from 6 to 8 inches in depth. Its exact location is determined by the volume of blast and the nature of the fuel employed in melting. A large volume of blast gives a high melting point, and a small volume a low melting point. A soft, combustible fuel gives a high melting point, and a hard fuel a low melting point, the blast being equal in volume with both fuels.

To do good melting the melting point must be discovered,

and only a sufficient quantity of fuel placed in the bed to bring the top of the bed up to the melting point. When the fuel is hard anthracite coal, the rule is to use a sufficient quantity of coal in the bed to bring the top of the bed 14 inches above the top of the tuyeres when the wood is burned out; with hard Connellsville coke 18 inches, and with soft coke 20 to 25 inches. But the melting point is varied by the volume of blast and these rules do not always hold good. So the melting point in each cupola must be learned to get the best results from the cupola.

To find the melting point a bed is put in according to the rule and iron charged upon it. If the iron is a long time in coming down after the blast is put on, or the iron melts very slowly during the melting of the first charge, but melts faster at the latter end of the charge and is hot, the bed is too high and the iron is being melted upon the upper edge of the melting zone. Fuel and time are then being wasted, and the fuel should be reduced so as to place the iron at the melting point when melting begins. If the iron comes down quick but is dull, or if it comes slow and dull and does not grow hotter at the latter end of the charge, the melting is being done on the lower edge of the melting zone and the quantity of fuel should be increased to bring the top of the bed up to the melting point. When the top of the bed is placed only half way up the melting zone, the iron comes down hot and fast, but the bed does not melt the quantity of iron it should and the latter part of the charge on the bed is dull. The latter part of the charge on the bed when the bed is the proper height is also dull if the charge is too heavy for the bed, and care must be taken in noting this point.

If by comparison with the charges of iron in various sized cupolas the charge on the bed is found to be light, the bed should be raised until the melting indicates that it is at a proper height; then the weight of iron on the bed may be increased, if the charge is too light. When raising or lowering a bed, it should be done gradually by increasing or decreasing

the fuel from 50 to 100 pounds each heat until the exact amount of fuel required in the bed is found. If the changes in the bed are made gradually in this way, the effect of the changes upon the melting may be observed more accurately and better results obtained than when a radical change is made by increasing or decreasing the fuel in large amounts at one heat. When the amount of fuel is found that brings the top of the bed to a height that gives the best results in melting, the top of the bed is maintained at that point each heat.

When a cupola is newly lined the diameter is decreased from what it was with the old lining, and the weight of fuel in the bed must be decreased to bring the top of the bed down to the melting point, and as the lining burns out and the cupola gets larger the fuel must be increased to keep the bed up to the melting point. Trouble is often experienced in melting after a cupola has been newly lined. This is because the diameter of the cupola is reduced from 6 to 10 inches, and the bed and charges are not changed to correspond with the reduced size of the cupola. There is never any trouble of this kind in foundries where a cupola book is provided and a record kept of the melting from one year's end to another, for the melter or foreman can look back and see the weight of the bed and charges when the cupola was newly lined, and the increase made in the weight as the lining burned out and the diameter increased.

No definite or even approximate weight can be given of the amount of fuel required for a bed in cupolas of different diameters, for the tuyeres are placed at such a variety of heights above the sand bottom that for two cupolas of exactly the same diameter twice the quantity of fuel may be required for a bed in one as is required for a bed in the other. Cupolas with two or three rows of tuyeres require a larger amount of fuel for a bed than cupolas with but one row, but the same general directions for burning and managing the bed apply to all cupolas.

CHARGING.

The old way, and the way still in vogue in some localities, of stocking, loading or putting the fuel and iron into a cupola is to place a sufficient quantity of fuel in the cupola to fill it above the tuyeres. On this fuel or bed are placed from 50 to 500 pounds of iron, according to the size of the cupola, then from one to four shovels of fuel are put in and from 50 to 200 pounds of iron, and so on until all the iron to be melted is placed in the cupola.

This way of stocking a cupola mixes the fuel and iron in the cupola and they come down to the melting point together. The fuel fills a space that should be filled with iron, and a great deal of the melting surface of the cupola is lost, and its melting capacity reduced in proportion.

The modern way of stocking a cupola is to put in the fuel and iron in layers or charges. Each layer or charge of fuel is separated from the layer or charge above and below it by a layer or charge of iron, and each layer of iron is separated by a layer of fuel. This way of stocking a cupola is known as charging the cupola. When a cupola is charged in this way the iron comes down to the melting point in a body extending over the melting surface of the cupola, and the entire melting surface is utilized. The melting capacity of a cupola is about one-half greater when charged in this way than when the fuel and iron are mixed, and the consumption of fuel is also less.

The first charge of iron is placed on the bed at the melting point. In melting this charge of iron a certain amount of fuel is consumed and the top of the bed settles down from the top of the melting zone to the bottom of the melting zone. The charge of fuel on top of the charge of iron that has just been melted settles with the iron until it unites with the bed and places the top of the bed again at the top of the melting zone, ready to melt the next charge of iron, and so on with each succeeding charge of fuel and iron throughout the heat. This is the correct theory of melting iron in a cupola, and the practice that must be followed to obtain the best results from a cupola.

Now, having described the theory of charging and melting, let us consider the practical working of a cupola upon this theory. The amount of iron placed upon the bed in the first charge and in each charge through the heat must be the exact amount of iron the fuel will melt while settling from the melting point to the bottom of the melting zone. The amount of fuel in each charge must be the exact amount required to raise the bed from the bottom of the melting zone to the melting point. If the charges of iron are made too heavy the iron comes dull at the latter end of the charge and hot at the first of the charge until a few charges have been melted, when it comes dull all through to the end of the heat. When the charges of iron are too light the iron comes hot, but there is a stoppage in melting at the end of each charge, changing to continuous but very slow melting as the heat progresses.

When the charges of fuel are too heavy the iron melts slowly and unevenly, and if the heat is a long one it comes dull and is hardened in melting. When the charges of fuel are too light and the charges of iron heavy, the result is dull iron. When the charges of fuel and iron are both too light the iron generally comes hot but slowly throughout the heat, and the full melting capacity of the cupola cannot be realized.

There is no rule for making the weight of the first charge of iron of any definite proportion to the weight of the bed of either anthracite coal or coke that holds good in all cupolas. Manufacturers of some of the patent cupolas have such a rule for their cupolas that is approximately correct, but the tuyeres in different sizes of these cupolas are always placed at the same height and about the same amount of fuel is required for a bed. The bed will melt a heavier charge of iron in settling than the other charges of fuel, and the first charge is generally made from one-third to one-half heavier than the subsequent charges. The weight of the first charge of iron varies from two and one-half to four and one-half times the weight of the bed with anthracite coal; with coke the weight of the first charge varies from one and one-half to three and one-half times the weight of the bed.

These wide variations in the weight of the first charge of iron in proportion to the weight of the bed are largely due to the difference in the height of tuyeres and the large amount of fuel required for a bed in a cupola with very high tuyeres. But variation is also due in many cases to bad judgment in estimating the weight the first charge should be. The greater the weight of the first charge in proportion to the weight of the bed, the better the average will be in melting, and careful experiments should be made with every cupola to learn the largest amount of iron it will melt on the bed with safety, and that amount should always be placed in the first charge.

There is no rule for making the weight of the charges of fuel or iron of any definite proportion to the weight of the bed or first charge of iron, and the weight of the charges of both fuel and iron is frequently changed in different parts of the heat, to give a hotter iron for some special work or to make the iron run of an even temperature through the heat. In practice, the weight of the charges of iron to the charges of anthracite coal varies from 6 to 14 pounds of iron to the pound of coal. With coke they vary from 6 to 15 pounds of iron to the pound of coke. These variations in the per cent. of iron to fuel are due in many cases to the quality of fuel and in many other cases to poor judgment in working the cupola. In all cases the charge of iron should be made as heavy as the charge of fuel will melt and produce good hot iron for the work, for this is the only way a good per cent. of iron to the pound of fuel can be obtained.

PLACING THE CHARGES.

The top of the bed is made as level as it can be before charging the iron, and the smoke must all have disappeared so the melter can see how to place the charges. When the cupola is very high a few hundred of stove plate or other light scrap is placed upon the bed to prevent the heavy pieces of pig or other iron breaking up the fuel and settling down into the bed when thrown in. The pig should be broken into short

pieces and placed in the cupola with the end toward the lining. The pieces of pig or other iron are placed close together so as to utilize all the heat and prevent its escape up the stack, and each charge is made as level as it can be on top. The gates and cupola scrap are placed on top of the pig and are used to fill up holes and level up the charge. Old scrap is generally charged with the pig when heavy, and on top of the gates when light. Rattle barrel iron and gangway scrap or riddlings go in with the gates, a few shovels to each charge.

The charge of fuel is distributed evenly over the charge of iron, and the second charge of iron is put in the same as the first, and the second charge of fuel the same as the first, and so on until the cupola is filled to the charging door. Charging is then stopped and the door closed until the blast goes on. When melting begins the stock begins to settle, and the door is opened and charging continued as before until all the iron to be melted is placed in the cupola. While charging is going on the cupola is kept filled to the charging door to prevent the gas igniting and making a hot flame at the charging door, which makes it hot for the men and difficult to place the charges of fuel and iron properly. When charging is finished the charging door is closed to prevent sparks or pieces of burning fuel being thrown upon the scaffold.

When the charges have been arranged, the next important matter to be considered is the placing of iron in the cupola. To obtain an even quality of iron at the spout, too great care cannot be taken in charging, for this is the first step in mixing irons when melted in a cupola. This is an important matter that does not appear to be fully understood by melters, and irons are frequently placed in cupolas without any regard to mixing them, under the impression that irons mix when melted; which is not the case, if irons are not placed so that they come in direct contact with each other in small bodies, as soon as melted.

When not mixed in charging, and the iron drawn close in small ladles, the different grades of iron charged may be drawn

from the cupola and found in the casting without having mixed with each other, and this is frequently the cause of hard and uneven castings.

No rule can be given for mixing irons in charging that will hold good in all cases, owing to the great differences in iron melted for the various classes of work.

In some foundries pig is melted with only a limited amount of remelt scrap; in others the remelt is more than fifty per cent. of the entire heat; while in others the greater part of the heat is old scrap.

When melting pig with a limited amount of remelt scrap only, the pig should be placed on the bed and charges of fuel, as should also pieces of scrap that are as heavy as pig, and on this a limited amount of light scrap should be placed. Each charge of pig should be made as level as possible on top, and the light scrap evenly distributed over it. When charged in this way the scrap melts at the same time as the pig, and a thorough mixture of the pig and scrap is effected at the spout.

When charging pig of different grades no two pieces of the same grade should be placed together if it can be avoided. This gives a better mixture than when all of one grade is placed on one side of a cupola and another grade on the other side.

The pig should be placed with one end toward the lining as far as possible, and the side of a pig should never be placed against the lining, for a pig so placed is protected to a greater or less extent from the heat by the lining, and does not melt so freely as when fully exposed to the heat, and is frequently found lodged over the tuyeres in cinder, adhering to the lining.

When melting pig with a large per cent. of remelt, such as small gates and light scrap, the pig should be broken into four or more pieces, for pig melts from the freshly broken ends, and when broken short melts more readily, and may be melted almost as quickly as gates and other foundry scrap that is protected to a greater or less extent against melting by a coating of sand.

The charges when heavy should be divided into from two to four parts or drafts, and a layer of pig placed upon the fuel, upon this a layer of scrap, upon this a layer of pig, and so on until the entire charge is put in.

When pig and a large per cent. of scrap are mixed in this way in charging, a better mixture is obtained at the spout than when all the pig is placed upon the fuel and the scrap on top of it.

When melting old scrap and pig the manner of charging must depend to a large extent upon the character of the scrap. When the scrap is heavier than the pig it should be placed upon the bed and fuel in the charges, and the pig on top of it. If the scrap is as heavy as the pig, it should be mixed with the pig. When light and in small quantities, it should be charged on top of the pig; and when fifty per cent. or more of the heat is light scrap, it should be mixed with the pig in the same manner as when melting a large per cent. of gates and foundry scrap.

A poor heat was never melted because the melter failed to put up the bottom doors, put in a sand bottom, light a fire, or to charge fuel and iron. It is not the failure of the melter to do these things that causes poor melting, but his failure to look after the small details in doing them.

When the iron is all or nearly all melted that has been charged, and it is discovered there is not sufficient iron in the cupola to pour off the work, more iron is sometimes charged. At this stage of the heat the stock is so low in the cupola and the heat is so intense that the cupola is in a very bad condition for resuming charging to melt more iron. It is only a waste of fuel to charge it into the cupola at this stage of the heat, and the only iron that can be melted on the fuel already in the cupola is light scrap, and but a limited quantity of it. When the charging door is opened the heat at the opening is so intense that the men cannot go near it, and the scrap must be thrown in from a distance or by standing alongside of the cupola out of the heat and throwing the iron around into the door on a shovel.

Poor melting may be due to bad charging. Iron or fuel should never be dumped into a cupola from a barrow, for it all falls on one side of the cupola. The iron generally lies where it falls in a pile, and the fuel rolls on the other side of the cupola, and good melting cannot be done with the fuel on one side and the iron on the other. This way of charging is about equal to the old way of mixing the fuel and iron, and only about one-half of the melting capacity of the cupola can be realized. Fuel should never be emptied into a cupola from a basket or box, for it all falls in one place and cannot be spread evenly over the charge of iron. To charge a cupola properly the iron must all be thrown in with the hands, and the fuel with a shovel or fork.

CHARGING FLUX.

When it is desired to tap slag, the slag-producing material or flux is charged in the cupola on top of the iron and evenly distributed. The flux is sometimes put on each charge of iron, but generally about one-sixth of the heat is charged without flux. After that, flux is put in on every charge of iron except the last one or two charges, where it is not required if the proper amount has been used through the heat. The quantity of flux required depends upon the slag-producing propensity of the material used and the condition of the iron charged, and is from 30 to 100 pounds to the ton of iron melted. If the iron to be melted is all clean iron, the amount of flux required is less than when the iron is dirty scrap or a large per cent. of the heat is sprues and gates that have not been milled and are melted with a heavy coating of sand on.

If it is not desired to tap slag and the flux is used only to make a brittle slag in the cupola, it is charged in small quantities of from 5 to 10 pounds to the ton of iron, and is placed around the outside of the charge near the lining. Flux is sometimes charged in a cupola in a sufficient quantity to produce a large body of slag through which to filter the molten iron and cleanse it of impurities, but not in a sufficient quantity

to admit of slag being drawn from the cupola. This way of fluxing works very well in a short heat, but in a long heat the slag sometimes absorbs a large amount of impurities, becomes overheated and boils up in the cupola and fills the tuyeres, and when boiling the slag cannot be drawn from the cupola at the slag hole and the bottom generally has to be dropped.

BLAST.

Before the blast is put on the tuyere doors are all tightly closed and luted to prevent the escape of any of the blast during the heat, and they should be examined from time to time to see that the luting has not blown out and the blast is not escaping. The blower is speeded up to the full speed at once, and the full volume of blast given the cupola from the start. The old way of putting on the blast light and increasing or decreasing it at different stages of the heat has been abandoned by practical foundrymen, and the cupola is given the same blast from the beginning to the end of the heat. This is the only way good melting can be done in a cupola charged in the manner before described. If the cupola does not work properly, remedy the evil by changing the charges, but never vary the blast in different parts of a heat to improve the melting.

When the blast is first put on, it is indicated by a rush of blast from the tap hole and at the charging door by a volume of dust passing up the stack. Then follows a bluish colored gas which bursts into a bluish flame as the stock settles, changing to a yellowish hot flame as the stock sinks still lower. If the stock is kept up level with the charging door in a cupola of good height the gas does not ignite, and it is the aim of the chargers to keep the stock up to this point until they are through charging. When the blast is shut off from a cupola for any cause or at the end of the heat before the bottom is dropped, one or more of the tuyere doors are at once opened to prevent gas from the cupola passing into the blast pipe, where it is liable to explode and destroy the pipe.

The full consideration of the blast for a cupola would take up more space than we care here to give to it and would lead our readers too far from the subject of working a cupola. We shall therefore leave it for fuller consideration under another heading.

MELTING.

Melting begins in a cupola soon after the blast is put on, and the exact length of time is indicated by the appearance of molten iron at the tap hole. When the iron is charged two or three hours before the blast goes on, and the bed is not too high, iron flows from the tap hole in from three to six minutes after the blast is on. When the iron is charged and the blast is put on, immediately iron appears at the tap hole in from 15 to 20 minutes, after the cupola is filled if the bed is not too high. When the bed is too high, iron melts when the surplus fuel is burned up and permits it to come down to the melting point, and it is very uncertain when melting will begin; and it is generally from half an hour to an hour before any molten iron appears at the tap hole. If iron does appear at the tap hole within 15 or 20 minutes after the blast is on, the bed is either too high or the fire has not been properly lit, and the bed is not doing its work efficiently.

Foundrymen differ as to the time for charging the iron before the blast is put on. Some claim that fuel is wasted by lighting the fire early and charging the iron two or three hours before the blast is put on, while others claim fuel and power are only wasted by putting on the blast as soon as the iron is charged. We have melted iron in both ways, and we prefer to charge the iron from two to three hours before the blast is on, except when the cupola has a very strong draft that cannot be shut off, as is sometimes the case when there is no slide in the blast pipe for shutting off the blast, and as air is supplied to the cupola through the pipe. When iron is charged and the cupola filled to the charging door with fuel and iron, and the draft shut off from the cupola, the combustion of fuel in the bed is very light and the heat that rises from it is utilized in

heating the first charge of iron. When the blast is put on, this charge of iron is ready to melt and iron comes down in a few minutes. When the blast is put on immediately after the cupola is charged the iron is cold, and time is required to heat it before it will melt, and the blower must be run 15 or 20 minutes before iron appears at the tap hole, and the first charge melts more slowly than when the iron has been heated before the blast is put on.

We think the best way is to put on the blast about two hours after the charging begins. When the blast goes on, the tap hole is open and is left open until the iron melts and runs hot and fluid from it. From 10 to 20 pounds are generally permitted to run from the spout to the floor to warm the spout and insure the iron being sufficiently hot not to chill in the tap hole after stopping in. The first iron melted is always chilled and hardened to some extent by the dampness of the sand bottom and spout, and when the work is light and poured with hand-ladles, a small tap of a few ladles is made in a few minutes after stopping in, and the iron used for warming the ladles and it is then poured into the pig bed or some chunks. In some foundries the cupola is not stopped in at all after the iron comes down. The first iron is used to warm the ladles, and as soon as the iron is hot enough for the work the molders begin pouring it. We recently ran off a heat of 31 tons in this way from a cupola for hand-ladle work without using a single bod for stopping in.

When the iron is handled in large ladles a tap is not made until a sufficient quantity is melted to fill a ladle or there is a sufficient body of iron in the cupola to insure it not chilling in the bottom of a large ladle before another tap is made. When the blast blows out at the tap hole after a tap is made, it indicates that the melted iron is all out of the cupola or the tap hole is too large, and the cupola should be stopped in until iron collects in the bottom, or the size of the tap hole should be reduced to prevent the escape of the blast. The size of the tap hole is reduced when it becomes too large to run a continuous

stream without blowing out, by stopping in with a bod of stiff clay and sand that will not cut, and as soon as the bod is set, cutting a new tap hole through the bod with the tap bar. Iron should be melted hot and fast, and it should never be drawn from a cupola for any kind of foundry work if it is not hot and fluid enough to run stove plate or other light castings. Iron is not burned in a cupola by melting it hot and fast, but is burned and hardened by melting it too high in the cupola and melting it slow and dull.

Nothing is gained by holding molten iron in a cupola to keep it hot, for it can be kept as hot in a ladle as in a cupola, and iron should be drawn from a cupola as fast as melted or as fast as it can be handled in pouring the work. If we were running a foundry we should never stop in the cupola except to get enough iron to give a gang of men a hand-ladle full all round, or to remove a large ladle from the spout. When the cupola is very small and melts slowly it is sometimes necessary to stop in and collect iron in the cupola, but it is not necessary to stop in a large cupola for this purpose. If the iron is all poured with hand-ladles the men should be divided into gangs, with only enough men in each gang to take away the iron as fast as melted. If this is not done and there is a large number of men, the ladles get so cold between catches that they chill the iron before it can be poured, and the melter is blamed for not making hot iron.

The flow of iron from the tap hole indicates how the cupola is melting. If it has been properly charged the flow will be even in quantity and temperature throughout the heat, except in a very long heat, when the stream will get smaller and the cupola not melt so fast toward the end of the heat. When too much fuel is used the iron melts slowly and grows dull as the heat progresses. When the charges of iron are too heavy the iron is not of an even temperature throughout the heat, but is dull at the latter end of every charge and hot at the beginning of the next charge. When the charges of fuel are too heavy the iron melts very slowly at the beginning of each charge and fast

at the latter end, and if the charges of iron are also too heavy, the iron is dull at the latter end of the charge. If the cupola melts unevenly it is not being properly worked, and the mode of charging should be changed until it does melt evenly from the beginning to the end of the heat.

POKING THE TUYERES.

When the blast is first put on, the fuel in front of each tuyere is bright and hot, but it is soon chilled and blackened by the large volume of cold blast passing in, and the tuyere presents the appearance of being closed up and admitting no air to the cupola. The blast when first put on does not remove the fuel and make a large opening in front of each tuyere to get into the cupola, but works its way between the pieces of fuel in front of the tuyeres, and these openings remain open for the passage of blast after the fuel becomes cold and black. The blast, therefore, passes into the cupola just the same as when the fuel was hot, and it is not necessary to poke the tuyere with a bar or break away the cold fuel in front of each tuyere to let the blast into the cupola.

Toward the end of a long heat, slag and cinder settle and chill at the bottom of a cupola, and often not only close off the blast at the tuyeres, but prevent it passing freely through the stock and out at the top. If the tuyeres are poked at this stage of the heat an opening may be made well into the stock. But in working the bar around in forming this opening most of the natural passages the blast has made for entering the stock are closed up. The new opening is only a hole bored into a tough slag or cinder from which there is no way for the blast to escape into the stock, and less blast enters a cupola after the tuyeres have been poked and opened up than entered before. The only time a tuyere should be poked with a bar is when cinder or slag has lodged or formed in front of it in such a way as to run a stream of molten iron into the tuyere. The tuyere door should then be opened and the slag or cinder broken away with a bar to prevent the iron running into the tuyere.

FUEL.

Theoretically ten pounds of iron are melted with one pound of anthracite coal, and 15 pounds with a pound of Connellsville coke. But this melting is done in the foundry office or in the mind of the foreman, and it takes a little more fuel to melt iron in a cupola for foundry work. Six pounds of iron to 1 of anthracite coal and 8 pounds of iron to 1 of Connellsville coke is by practical foundrymen considered good melting. A little better than this can be done in a full heat for the size of the cupola and under favorable circumstances, but in the majority of foundries fewer pounds of iron are melted to one of fuel than the above amount.

It is sometimes necessary for the melter to put in a few extra shovelfuls of fuel when the bed has been burned too much before charging, or to level up the charges when two or three men are shoveling in fuel at the same time and get it uneven. The melter is generally blamed if the iron from any cause comes dull, and he will generally put in a few extra shovelfuls of fuel the next heat to make it hot, and if the iron does come hot the next heat the extra shovelfuls are put in every heat, but are not put on the cupola report. In this way foundrymen are often misled by the cupola report and suppose they are melting more pounds of iron to the pound of fuel than they really are. The only way the foundryman can know exactly how many pounds of iron he is melting to the pound of fuel is to have an accurate account kept of the amount of iron melted and compare it with the amount of fuel bought and delivered for the cupola, after deducting from it any amount that may have been consumed in stoves or core ovens.

We recently met a foundryman who thought he was melting 14 pounds of iron to the pound of fuel, but when he came to compare the iron melted with the fuel bought and delivered for the cupola he found he was only melting about 7 pounds of iron to the pound of fuel; and about the same results would be found in every foundry that is claimed to be melting a very large per cent. of iron to fuel. There is nothing gained by

saving a few cents' worth of fuel in the cupola and losing a dollar's worth of work on the floor by dull iron, and there is nothing gained by using too great a quantity of fuel, for too much fuel in a cupola makes dull iron as well as too little fuel.

Iron is not melted in a cupola for the fun of melting it or to learn how many pounds of iron can be melted with a pound of fuel, but is melted to make castings. What the foundryman wants from the cupola at the tap hole is an iron hot and fluid enough to make a sound casting, regardless of the amount of fuel required to produce it. As before stated, iron cannot be melted hot and fast in a cupola with either too much or too little fuel, and foundrymen have only to melt their iron as hot and fast as it can be melted in a cupola of the size they are using, to know that they are not using either too much or too little fuel in melting.

If the foundryman will ask his neighbor what is the size of his cupola, how many tons does he melt per hour, how long does it take him to run off a heat, he will get a better guide to run his cupola by, than if he asks him how many pounds of iron he melts to the pound of fuel. As soon as the founder undertakes to imitate his neighbor and do faster melting or get better results from his cupola, he will hear the old, old story from both melter and foreman: "We haven't enough blast." More cupolas have too much blast than too little, and the apparent deficiency of blast is due in the majority of cases to too much fuel in the cupola and the iron being melted only on the upper edge of the melting zone. It does not make any difference how much or how little blast a cupola has. If it is given an even volume of blast throughout the heat, the cupola will melt a stream of iron of an even size and temperature throughout the heat except toward the end of a long heat, when the stream may get smaller. If the melter cannot run this kind of a stream from his cupola with an even blast, then he is at fault, and neither the blast, nor too much fuel, is the cause of the uneven melting.

We have watched the charging of cupolas in a great many

stove and machinery foundries, and as a rule more fuel is consumed in making dull iron in a machine foundry than is consumed in making hot iron in a stove foundry. This is simply because hot even iron cannot be produced with bad working of a cupola and too great a quantity of fuel, and the stove founder must have his cupola properly worked or he cannot use the iron to pour the work.

TAPPING BARS.

Tapping bars are made of round iron of from $\frac{1}{2}$ to 1 inch diameter, and are from 3 to 10 feet long. The hand bars are made with an oval ring at one end to serve as a handle for rotating and withdrawing the bar when tapping. The other end is drawn down to a long sharp point for cutting away the bod and making the tap hole. The bars for sledging are made straight with a long sharp point at one end. This bar is only used in case the tap hole becomes so tightly closed that it cannot be opened with the hand bar, and seldom more than one is provided for a cupola. From three to six hand bars are provided for each cupola, and when the ladles are all of the same size the tap bars are all made of the same size, except one or two small ones which are provided for clearing the hole of any slag or dirt that may be carried into it by the iron.

When the iron is melted for different sized work and large and small ladles are used, the bars are of different sizes, so that a large or small hole may be made to suit the tap to be made or ladle to be filled. The bars are all straight except when the tapping is done from the side of a long spout. They are then slightly curved near the point, so that the hole can be made in a line with the spout. The bars are dressed and pointed at the forge before each heat, and are given any shape of point the melter may fancy. A square point cuts away a bod very rapidly when rotated and leaves a nice, clean hole, but it is very difficult to keep a point square, for it generally becomes round after a few taps have been made and it comes in contact with the molten iron a few times. For this reason the bars are generally made round at the forge.

Some melters have a short steel bar, with a sharp flat point, which they use for cutting away the bod before tapping, but never use it for opening the hole. This they do to remove the greater part of the bod from the spout before tapping, and prevent it getting into the ladles. A hammer and an anvil, or an iron block, should be placed near the cupola for straightening the points and breaking cinder or dross from the bars, and a rack should be provided within easy reach of the tap hole, in which to place the tap bars on end until wanted for use. There is nothing more slovenly and dangerous about a foundry than to have the tap bars lying around the floor when a heat is being run, and it is just as bad to set them up against a post from which they are all the time falling down.

BOD STICKS.

Two kinds of bod sticks are used for stopping in a cupola; the wood stick and the combination wood and iron stick. The wood sticks are octagonal or round, from $1\frac{1}{2}$ to 2 inches diameter and from 5 to 10 feet long. They are made of both hard and soft wood and about an equal number of each wood, as some prefer one and some the other. When stopping in, the stick is held against the bod in the tap hole until it sets in the hole, and the stick generally takes fire from the heat of the spout. On this account they soon become small near the ends and have to be sawed off; for this reason they are always made longer than necessary and sometimes larger in diameter.

The combination stick is of the same diameter as the wood stick, and from 4 to 10 feet long. An iron ring is placed on one end of the stick, and a rod of round iron of from $\frac{1}{2}$ to $\frac{5}{8}$ inch diameter and 1 to 3 feet long is placed in the end of the stick. On the end of the rod is placed a round button of from $1\frac{1}{2}$ to 2 inches diameter, for carrying the bod. The object of the rod is to prevent the stick being burned by the heat of the spout every time the cupola is stopped in, and the length of the rod is made to correspond to the length of the spout. The objection to the combination stick is that the button does not

carry the bod as well as the wood stick, and the button and rod must be wet every time the stick is used to keep it cool, or the heat will dry out the bod and it will fall off. This repeated wetting rusts the button, and if the edges come in contact with the molten iron it makes the iron sparkle and fly; and for this reason most foundrymen prefer the wood sticks, even at the extra expense of keeping them up.

An iron rod and button without the wood stick is also used in some foundries for stopping in, but they were not used by our grandfathers and are not popular with melters. Three or four bod sticks are provided for each cupola. They are placed on end in a rack alongside of the tap bars, within easy reach of the tap hole, and a bod is kept on each stick all the time the cupola is in blast.

BOD MATERIAL.

The bod is a plug used for closing the tap hole when it is desired to stop the flow of iron from a cupola, and the material of which the bod is composed has a great deal to do with the nice working of the tap hole. When the bod is composed of fire clay, or largely of fire clay, it does not give up the water of combination rapidly, and if a tap is quickly made after stopping in, the iron sputters and flies as it comes out of the hole. If the bod is permitted to become perfectly dry it bakes so hard that it cannot be cut away with the hand bar, and the heavy bar and sledge have to be used to make a hole of the proper size. If a friable sand is used it crumbles easily before the bar and a nice clean hole can be made; but it does not hold well, and if the cupola is stopped in for any length of time the bod may be forced out by the pressure of metal.

Some of the loams make an excellent bod that holds well and is easily cut away with the point of the bar, and leaves a clean hole. Some of the molding sands also make good bods in their native state, and there are several materials that are peculiar to certain localities that make good bods. When a suitable material cannot be found it must be made by mixing

two or more materials. A good bod is made by mixing blue or yellow clay and molding sand. When these clays cannot be procured, a good bod can be made by mixing just enough fire clay with the molding sand to give it a little greater adhesive property, but not enough to make it bake hard. When a large body of iron is collected in the cupola before a tap is made, the bod material must be strong, and bake in the hole sufficiently hard to resist the pressure of the iron, and an entirely different material must be used for this kind of tapping than is used when the cupola is only stopped in for a few minutes at a time.

Small cupolas from which only a small hand ladle is drawn before it is stopped in also require a different bod, for the hole has hardly time to clear itself before it is stopped in again, and if the bod burns hard or sticks in the hole, the hole is so hard to open that the small amount of iron is chilled by the bar and slow tapping before it can be run out. This kind of cupola requires a bod that will crumble and fall out as soon as touched, or burn out as soon as the hole is opened. A nice bod is made for this kind of work by mixing clay, molding sand and sawdust and making it fully half sawdust. Blacking or sea coal is also mixed with bod material to make it more porous when burned and crumble more readily when tapping.

Horse manure was at one time considered to be one of the essentials of a good bod, but it has been replaced by blacking or sawdust, and is seldom used. A good bod should have strength to resist the pressure of molten iron in the cupola and at the same time break away freely before the iron and leave a clean hole. Such a material can be made suitable for any cupola, no matter how it is tapped, and a bod material should never be used that requires the sledging tap bar to open the tap hole.

TAPPING AND STOPPING IN.

When the blast is put on the tap hole is always open, and is left open until the iron melts and flows freely and hot from the hole. This is generally in from 5 to 20 minutes after the blast

is on. While the melter is waiting for the iron, he arranges his tap bars, bod stuff and bod sticks, and places a bod on each stick to be ready for instant use. The bod material is worked a little wetter than molding sand to make it adhere to the end of the bod stick or button, but care must be taken not to have it too wet or it will make the iron fly when stopping in, and, furthermore, the bod does not hold well when too wet. The bod is made by taking a small handful of the bod stuff and pressing it firmly on the end of the stick with the hand. The size and shape the bod is made depend upon how the iron is tapped and the size of tap hole. When the hole is small and only stopped in for a few minutes at a time a small bod stick is used, and the bod made very small and shallow and only pressed into the hole a short distance, so that it can be quickly broken away when tapping. When the hole is large or has to be stopped in until a large body of iron collects in the cupola, the bod is made large, long and pointed, so that it may be pressed well back into the hole and stay in place until removed with the tap bar.

The first iron melted flows from the hole is a small stream, and generally chills in the hole or spout and has to be removed with the tap bar; but it soon comes hot enough to clear the hole, which is then closed, unless the first iron is used to warm the ladles and the hole is kept open throughout the heat. If the work is light, a small tap is made in a few minutes to remove any iron that has been chilled and dulled by the dampness in the sand bottom. But when the work is heavy this tap is not made and the molders go on with their regular pouring from the start. The tap is made by placing the point of the bar against the bod and giving it a half forward and back rotation and at the same time pressing it into the bod, or by carrying the handle end of the bar around in a small circle and at the same time pressing it in. As soon as the bod is cut through, the bar is run into the hole once or twice and worked around a little to remove any of the bod that may be sticking round the sides of the hole. The bar must always be held in such a posi-

tion as will make the hole in a line with the spout, or the stream will not flow smoothly and may shoot over the sides of the spout and burn the men catching in.

When about to stop in, the bod is placed directly over the stream close to the tap hole and the other end of the stick is elevated at a sharp angle from the spout. The hole is closed by a quick downward and forward movement of the stick that forces the bod into the hole and checks the stream at once. The stick is then held against the bod for a few seconds until the force of the stream is stopped and the heat has set the bod fast in the hole. The part of the bod that does not enter the hole is then removed with the stick to keep the spout clean, and the stick is dipped in water to cool it, and another bod applied to be ready for the next time. There is a great knack in stopping in, that some melters never acquire. They hold the bod too far from the hole, and attempt to push it up, under or through the stream; they get nervous and are not sure of their aim and strike the stream too soon, or the side of the hole, and the iron sputters and flies in all directions.

The bod sticks are frequently made so long and slender or so heavy that it is impossible to accurately place the bod, and it is sometimes difficult to get the cupola stopped in with these long sticks. It is also difficult to stop in when the cupola is placed very high, for the melter cannot get up to place the bod stick at a proper angle for stopping in, and has to run the bod up through the stream, in place of cutting off the stream with the bod. An arm or bracket is sometimes placed over the spout near the tap hole, when long bars and sticks are used, upon which to rest the tap bars and bod sticks when tapping and stopping in. But a better plan is to construct a movable platform that can be placed alongside the spout for the melter to stand on. He can then use short bars and sticks, and has much better control of the tap hole than with the long bars and sticks.

At the tap hole is seen the skill of the melter in the results obtained from his labor. If the bed has been burned too much

the first charge comes down fast and slack or dull. If the bed is too high the first iron is a long time in coming down. If too much fuel is used, the iron melts slowly and is dull toward the last if the heat is long. If the charges of iron are too heavy, the iron comes dull at the end of each charge. If the charges of fuel are too large, there is slow melting at the end of each charge. If the iron flows from the tap hole with great force and is difficult to control, the sand bottom has too much pitch. If slag flows freely from the tap hole with the iron, the hole is too large or the bottom has too much pitch. If the spout melts, crumbles or chips off, the material is poor or has not been properly mixed. If the tap hole cuts out, the material is poor or the tap hole has not been properly made. If the tap hole gums up and cannot be kept open, the front material is poor and is melted by the heat, and it may also be melted by the heat when it is good if rammed soft and ragged inside. If the tap hole cannot be opened without a sledge and bar, the bod bakes too hard and the material should be changed. If the bod does not hold, the material is not good or the bod is not put in right. If the cupola does not melt evenly throughout the heat and the same every heat, it is the fault of the melter and not of the cupola.

DUMPING.

As soon as the molders are through pouring their work, if there is no iron to be melted for other purposes, preparations are at once made for dumping the refuse from the cupola. The blast is first shut off by stopping the blower and the tuyere doors are at once opened to prevent the escape of gas from the cupola into the blast pipe, where it might do much harm. The melted iron in the cupola is then drawn off by the cupola men and poured in the pig bed. If there is a lot of small iron in the cupola that has not been melted time is given it to melt to save picking it out of the dump, but if there is a lot of pig or other heavy iron unmelted it is let fall with the dump, and the bottom is dropped as soon as the melted iron is drawn off.

The small props supporting the bottom are first removed and laid away. The main prop is then removed by striking it with a long bar at the top or pulling with a hooked bar at the bottom, and the instant it falls the doors drop. When the doors of a large cupola drop, the sand bottom and a greater part of the refuse of melting falls with them and a sheet of flame and dust instantly shoots out ten feet or more from the bottom of the cupola in all directions. But the flame disappears in an instant and the dust settles, revealing the white hot dump in a heap under the cupola. The cupola men then throw a few buckets of water on it to chill the surface and deaden the heat, and the melter puts a long bar into the tuyeres and tries to dislodge any refuse that may be hanging to the lining while it is hot. Small cupolas do not dump so freely, and the sand bottom has frequently to be started with a bar after the door drops. A long bar must be used for this purpose, and the melter must be on his guard, for the dump may fall as free as from a large cupola the instant it is started and a sheet of flame shoots out.

Small cupolas frequently bridge over above the tuyeres, and only the sand bottom and refuse below the bridge are dumped when the door falls. The aim of the melter is then to break away the bridge or get a hole through it, so that the cupola will cool off in time to be made ready for the next heat. He puts a bar in at the tuyeres and breaks away small pieces at a time, and if there is not a large body of refuse in the cupola, a few short pieces of pig are thrown in from the charging door, so that they will strike in the center and break through the bridge. This bridging and hanging up of the refuse in a cupola when only run for a few hours is entirely due to mismanagement, for any cupola, no matter how small it may be, can be run for six or eight hours without bridging and be dumped clean if properly worked.

When the dump falls from a cupola it is a semi-fluid mass of iron, slag, cinder, dirt and fuel. This mass falls in a heap under the cupola, and if scattered or broken up when very hot

it is more readily wet down and more easily removed when cold. In some foundries a heavy iron hook or frame is placed under the cupola before dumping and is withdrawn with a chain and windlass after the dump has fallen upon it and been partially cooled with water to harden it so that the hook will not slip through it without breaking it up and scattering it. In other foundries it is scattered with a long rake or hook worked by hand. In pipe foundries two or three short lengths of condemned pipe are placed under the cupola before dumping, and the dump is broken up by running a bar into the pipe and lifting it up after the dump has been slightly cooled. But in a great many foundries where the dump is small or where there is plenty of room to remove it when cold, it is let lie as it falls and is wet down by the cupola men, or a few buckets of water are thrown on by the cupola men to deaden it, and it is left for the watchman to wet down during the night. Care must be taken not to use too much water, or the floor under the cupola will be made so wet that there will be danger of the dump exploding when it falls upon it the next heat.

REMOVING THE DUMP.

A number of plans have been devised for removing the dump from under the cupola. Iron cars or trucks have been constructed to run under the cupola and receive the dump as it falls, but they cannot be used unless there is sufficient room for the doors to swing clear of the car, and few cupolas are so constructed. The dump must be removed from the car when hot to avoid heating and injuring the car, and considerable room is required for handling the car after it is taken from under the cupola. For these reasons cars are seldom used. Iron crates have been made to set under the cupola and receive the dump and be swung out with the crane, but they get fast under the cupola and are soon broken, and it is almost as much work to handle the dump from the crate as it is from under the cupola. A number of other plans have been tried, but the dump must be picked over by hand, and it is as cheap to pick it over at

the cupola and remove it in wheelbarrows as by any way that has yet been devised. The dump is broken up with sledge and bar when cold and picked over. The large pieces of iron are picked out and thrown in a pile for remelting. The coke is thrown in a pile to be taken to the scaffold or core oven furnace. Anthracite coal that has passed through a cupola and been subjected to a high heat will not burn alone in a stove or core oven furnace, and it is very doubtful if it produces any heat when mixed with other coal and again put in the cupola, and only the large pieces are picked out, if any.

The cinder, slag and other refuse are shoveled into a wheelbarrow and taken to the rattle-barrels or dump. If the sand bottom is to be used over again it is riddled out in a pile and wetted. If not, it is removed with the cinder and slag. As soon as the bulk of the dump is removed the melter goes into the cupola and breaks down the ring of cinder over the tuyeres and chips off any that may be adhering to other parts of the lining. The dump is then all removed and the floor around the cupola is cleaned up preparatory to daubing up. Nothing is done with the dump after it is taken from the cupola but to recover the iron from it. This is done in two ways, by picking it over or milling it. The iron is often of the same color as the dump, and so mixed with it that it is almost impossible to recover it all by picking unless a great deal of time and pains be taken; and it is cheaper to throw out only the pieces of pig and shovel all the remainder into the tumbling barrels, where it is separated in a short time and all the iron recovered that is worth recovering.

CHIPPING OUT.

Before going into the cupola to chip it out the melter slashes one or two buckets of water around the lining from the charging door to lay the dust. He then goes in from the bottom if he can get in, but if the cupola is so badly bridged that he cannot get up into it, he takes a long bar and endeavors to break down the bridge from the charging door, or goes down into it from

the charging door, and with a heavy bar or sledge breaks it down. As soon as he gets a hole through large enough to work in, he goes down through it and with a sledge or heavy pick breaks down the shelf of slag and cinder that always projects from the lining over the tuyeres. He then takes a sharp pick and trims off all projecting lumps of cinder and slag and gives the lining the proper shape for daubing up. It is not necessary or advisable to chip off all the cinder and adherent matter down to the brick, for the cinder stands the heat equally as well as new daubing, and in some cases better. But all soft honeycombed cinder should be chipped off, and all projections of hard cinder that are likely to interfere with the melting or tend to cause bridging should be removed.

Some melters have a theory that to prevent iron running into the tuyeres they must have a projection or hump on the lining over the tuyeres, and they let the cinder build out from 3 to 6 inches thick and 6 to 12 inches deep at the base. These humps tend rather to throw iron into the tuyere than to keep it out, for the fuel becomes dead under the hump and the iron in its descent strikes the hump and follows it around into the tuyere. They also form a nucleus for bridging. The refuse of melting as it settles lodges upon these humps and is chilled by the blast. A small cupola with these humps over the tuyeres will not work free for more than an hour, while the same cupola with the humps removed and the lining straight would work free for two hours and dump clean. They also interfere with the melting and in large cupolas cause bridging. All humps that form on the lining above the melting point from bad charging or other causes should be removed, for they hang up the stock and retard melting.

The cupola picks generally used are entirely too light for the work to be done with them, and the handles are not firm enough. When the melter strikes a blow he cannot give the pick force enough to cut away the point desired and the handle gives in the eye, so that the pick glances off and cannot be held to the work. Repeated blows with a light pick turn the

edge and render the pick worthless and the melter has to do two or three times the work really necessary in chipping out the cupola, and then he does not get it right. What the melter wants is a heavy pick with a firm handle. Then he can hold the pick where he strikes and prevent it glancing off. He can strike a blow that will cut away the cinder at one stroke and not jar and injure the lining nearly so much as he would by repeated blows with a light dull pick. The melter should be provided with three picks made of the best steel, weighing 4, 6 and 8 pounds each. They should be furnished with iron handles solidly riveted in, or should be made with large eyes for strong wood handles. The picks should be dressed, tempered and ground as often as they get the least bit dull.

DAUBING.

After the cupola is chipped out the lining is repaired with a soft plastic adhesive material known as daubing, with which all the holes that have been burned in the lining are filled up and thin places covered, and the lining given the best possible shape for melting and dumping. There are a number of substances used for this purpose, some of which are very refractory, and others possess scarcely any refractory properties whatever and are not at all suitable for the purpose. Molding sand is frequently used for a daubing. It is easily and quickly wet up and mixed, is very plastic and readily put on, but possesses none of the properties whatever requisite to a good daubing. It crumbles and falls off as soon as dry in exposed places, and a lining cannot be shaped with it. Furthermore, when put on in places from which it is not dislodged in throwing in the stock, it melts and runs down and retards the melting by making a thick slag that is readily chilled over the tuyeres by the cold blast.

Some of the yellow and blue clays are very adhesive and refractory, and make good daubing alone or when mixed with a refractory sand. Ground soapstone and some of the soapstone clays from coal mines make excellent daubing. But probably

the best and most extensively used is that composed of fire clay and one of the silica sands known under various names in different sections of the country, and which we shall designate sharp sand. Fire clay is very plastic and adhesive when wet, but shrinks and cracks when dried rapidly. Sharp sand alone possesses no plastic or adhesive properties whatever and expands when heated. When these two substances, in exactly the right proportions, are thoroughly mixed, they make a daubing that is very plastic and adhesive, does not crack in drying, neither expands nor shrinks to any extent when heated, and resists the action of heat as well as fire-brick in a cupola. When not evenly mixed the fire clay cracks and the sand expands and falls out of the clay when heated, making an uneven and uncertain daubing.

Fire clay absorbs water very slowly, and it requires from 12 to 24 hours' soaking before it becomes sufficiently soft to be thoroughly and evenly mixed with the sand. A large soaking tub should be provided near the cupola and it should be filled with clay every day after the cupola is made up, and the clay covered with water and left to soak until the next heat. The clay and sand cannot be evenly mixed in a round tub with a shovel, therefore a long box and a good strong hoe should be provided for the purpose. The amount of sand a clay requires to make a good daubing varies from one-fourth to three-fourths, according to the qualities of the clay and sand, but generally one-half of each gives good results. The sand is added to the clay dry, or nearly dry, and the daubing is made as thick and stiff as it can be applied to the lining and be made to stick. The more it is worked in mixing the better, and if let lie in the mixing box for a day or two after mixing it makes a better daubing than if applied as soon as prepared.

Nothing is gained by using a poor, cheap daubing, for it does not protect the brick lining, but falls off or melts into a thick tough slag which runs down and chills over the tuyeres and retards the melting by bunging up the cupola, and more fuel and time are required to run off the heat. The daubing is

taken from the mixing box on a shovel when wanted for daubing and placed on a board under the cupola if the box is near at hand. When it is some distance from the cupola the daubing is placed in buckets or small boxes made for the purpose and conveyed to the cupola. The parts of the lining to be repaired are first brushed over with a wet brush to remove the dust and wet the lining so that the daubing will stick better. The daubing is then thrown on to the lining with the hands in small handfuls; it can be made to penetrate the cracks and holes better in this way than in any other, and stick better than when plastered on with a trowel. After the required amount has been thrown on in this manner, it is smoothed over with a trowel or wet brush and made as smooth as possible.

SHAPING THE LINING.

Daubing is applied to a lining for two purposes—viz., to protect the lining and to shape the cupola, the latter being by far the more important of the two. A great many melters never pay any attention to it, their only aim being to keep up the lining, and they pride themselves on making a lining last for one, two or three years. Nothing is gained by doing this if the melting is retarded by doing so and enough fuel consumed and time and power wasted every month to pay for a new lining. Besides, a lining will last just as long when kept in good shape for melting as when kept in a poor one, and the aim of the melter should be to put the lining in the best possible shape for melting and make it last as long as he can.

New linings are made straight from the bottom plate to the charging door when the cupola is not boshed. When it is boshed the cupola is made of a smaller diameter at and below the tuyeres, and the lining is sloped back to a larger diameter from about 6 inches above the tuyeres, with a long slope of 18 or 20 inches. In the straight cupola, slag and cinder adhere in every heat to the lining just over the tuyeres, and if not chipped off close to the brick after each heat, gradually build out and in time a hard ledge forms that is difficult to remove.

It furthermore reduces the melting capacity of the cupola by increasing the tendency to bridge. Above this point at the melting zone the lining burns away very rapidly and in every heat a hollow or belly is burned in at this point that requires repairing. Above the melting zone the lining burns away very slowly and evenly and seldom requires any repairing until it becomes so thin that it has to be replaced with a new one.

The cinder and slag that adhere to the lining just over the tuyeres must be chipped off close to the brick every heat, and the lining made straight from the bottom plate to 6 inches above the top of the tuyeres. No projection or hump of more than $\frac{1}{2}$ or $\frac{3}{4}$ inch should ever be permitted to form or be made over the tuyeres to prevent iron running into them, and it should be placed right at the edge of the tuyeres when it is thought necessary to make it. The upper edge of the tuyere lining should be made to project out a little further than the lower edge, and the brick lining should be cut away a little under each tuyere so that molten iron falling from the top of the tuyere will fall clear of the bottom side of the tuyere and not run into it.

It is not necessary or advisable to fill in the lining at the melting zone and make it perfectly straight, as it is when it is new, for a cupola melts better when bellied out at the melting zone. It must, however, be filled in to a sufficient extent for each heat to keep up the lining and prevent it being burned away to the casing. No sudden offsets or projections should be permitted to form or remain at the upper edge of the melting zone, for the stock lodges in settling upon projections and does not expand or spread out to fill a sudden offset, and so the heat passes up between the stock and lining and cuts away the lining very rapidly. No sudden offset or hollow should be permitted to form at the lower edge of the melting zone over the tuyeres, for the stock will lodge on it in settling and cause bridging of the cupola. The lining should be given a long taper from 6 inches above the tuyeres to the middle of the melting zone, and a reverse taper from there to the top of the

melting zone. The belly in the lining should be made of an oval shape, so that the stock will expand and fill it as it settles from the top, and not lodge at the bottom as it sinks down in melting. As the lining burns away above the melting zone the straight cupola assumes the shape of the boshed cupola, and only the lower taper is given to the melting zone.

Daubing should never be put on a lining more than 1 inch thick, except to fill up small holes, and even then small pieces of fire brick should be pressed into it to reduce the quantity of daubing and make it firmer. All clays dry slowly and give up their water of combination only when heated to a high temperature. When daubing is put on very thick it is only skin dried by the heat of the bed before the blast goes on. The intense heat created by the blast glazes the outside of the daubing before it is dried through to the lining, and as there is no way for the moisture to escape, it is forced back to the lining, where it is converted into steam and in escaping shatters the daubing or tears it loose from the lining at the top.

In the accompanying illustration, Fig. 19, is shown a sectional view of a cupola that we saw at Richmond, Ind., in 1875. This cupola was a small one, about 35 inches diameter at the tuyeres, and the average heat was about 4 tons. The melter was a hard-working German, who knew nothing about melting whatever, and his only aim was to keep up the lining in the cupola. With this object in view he would fill in the hollow formed in the lining every heat at the melting zone with a daubing of common yellow clay and make the lining straight from the tuyeres up. The daubing required to do this was from 2 to 4 inches thick all around the cupola, and was put on very wet. The heat dried and glazed this daubing on the outside before it was dried through. There being no way for the water to escape, it was converted into steam, and in escaping from behind the daubing tore it loose from the lining at the top. The fuel and stock in settling got down behind the daubing and pressed it out into the cupola from the lining until it formed a complete bridge, with only a small opening in the

center through which the blast passed up into the stock. Before the heat was half over all the iron melted was running out at the tuyeres, and the bottom had to be dropped. When the cupola had cooled off, the daubing and stock were found in the

FIG. 19.

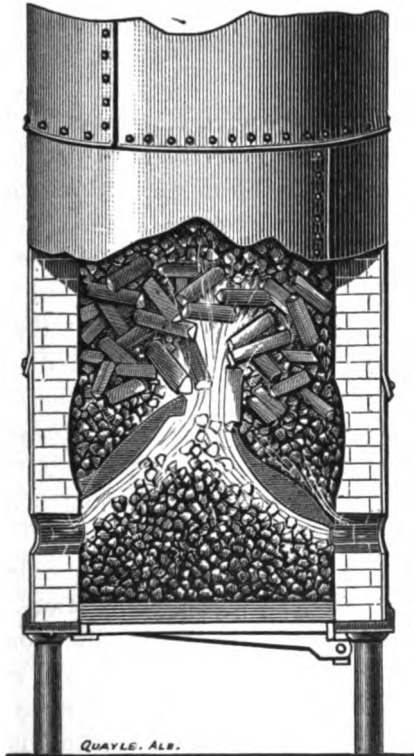

SECTION THROUGH BRIDGED CUPOLA.

shape shown in the illustration, and when the bridge was broken down it was found to be composed entirely of daubing that had broken loose from the lining in a sheet and doubled over.

This melter always had slow melting and difficulty in dumping. Some nights after dumping he would work at the tuyeres with a bar until eight o'clock before he got a hole through, so

the cupola would cool off by morning. The lining was not protected by the thick daubing, but was cut out more by the repeated bridging than if it had been properly coated with a thin daubing. We daubed this cupola properly and ran off two heats in it and melted the iron in less than half the time usually taken, and had no difficulty in dumping clean.

The lining of the boshed cupola does not burn out at the melting zone in the same shape nor to so great an extent as in the straight-lined cupola, and in shaping the lining it is made almost straight from the top of the slope to the bosh up to the charging door. The taper from the bosh to the lining should start at 6 inches above the top of the tuyeres, and should not be less than 18 or 20 inches long, and must be made smooth with a regular taper so that the stock will not lodge on it in settling. Should the cupola be a small one with a thick lining and only slightly boshed and burn out at the melting zone similar to the straight cupola, it must be made up in the same way as the straight cupola. The great trouble with boshed cupolas is that the melter does not give a proper slope to the taper from the bosh, but permits a hollow to form in the lining over the tuyeres, in which the stock lodges in settling and causes bridging out over the tuyeres.

These directions for shaping the lining only apply to the common straight and boshed cupolas. Many of the patent and odd-shaped cupolas require special directions for shaping and keeping up the lining as it burns out, and every manufacturer of such cupolas should furnish a framed blue print or other drawing, to be hung up near the cupola, showing the shape of the lining when new and the shape it should be put in as it burns away and becomes thin. Full printed directions should be given for chipping out and shaping the lining. All the improvements in cupolas are based on the arrangement of the tuyeres and shape of the lining, and when the lining gets out of shape the working of the tuyeres is disarranged, and the cupola is neither an improved one nor an old style, and is generally worse than either. More of the improved cupolas have

been condemned and thrown out for want of drawings showing the shape of the lining and directions for keeping it up, than for any other cause.

RELINING AND REPAIRING.

When a cupola is newly lined the lining is generally made of the same thickness from the bottom to the top except when the cupola is boshed. The casing is then either contracted to form the bosh or it is formed by putting in two or more courses of brick at this point. The lining varies in thickness from $4\frac{1}{2}$ to 12 inches, according to the size of the cupola, the heavier linings always being put in large cupolas. The greatest wear on the lining is at the melting zone, where it burns away very rapidly. From this point up it burns away more gradually and evenly, but the greatest wear is toward the bottom, where the heat is the greatest, and so a cupola gradually assumes a funnel shape with the largest end down and terminating at the melting zone, and the lining is always thinnest at about this point when it has been in use for some time.

At and below the tuyeres the destruction of the lining by heat is very slight, and the principal wear is from chipping and jarring in making up the cupola. At the charging door the principal wear is from the stock striking the lining in charging. In the stack the lining becomes coated with sulphides and oxides and is but little affected by the heat. A stack lined with good material properly put in generally lasts the lifetime of the cupola. The length of time a cupola lining will last depends upon the amount of iron melted and the way in which it is taken care of, and varies from six months to three or four years when the cupola is in constant use.

A lining burns away very rapidly at the melting zone, and if not repaired every heat would burn out to the casing in a few heats. Above the melting zone it burns away more slowly and evenly, and gets thinnest just above the melting point. From this point it gradually grows thicker up toward the charging door, where the wear is comparatively slight. The thickness

of lining required to protect the casing where the heat is most intense depends upon the quality of the fire-brick and how the lining is put in. A lining of good circular brick made to fit the casing, and laid up with a good, well-mixed grout, remains perfectly solid in the cupola as long as it lasts, and may be burned down to $1\frac{1}{2}$ inches in thickness, and even less, for several feet above the melting point. When the brick do not fit the casing and large cracks or holes have to be filled in with grout, and daubing or the lining is poorly laid up, it becomes shaky as it burns out and in danger of falling out, and it cannot be burned down so thin as when solid.

It is therefore cheaper in the long run to get brick to fit the casing and have the lining well put in. It will then only be necessary to reline when the lining gets very thin almost up to the charging door. The lining at the melting zone, where it burns away the fastest, is often taken out for 2 or 3 feet above the tuyeres and replaced with a new one when it is not necessary to reline all the way up. In repairing a lining in this way the same sized bricks are generally used as were used in lining. The lining has been burned or worn away above and below the point repaired, and the new lining reduces the diameter of the cupola to the smallest at the very part where it should be the largest. The result is that the new lining is cut away faster than any other part, and after a few heats it is as bad as it was before the new section was put in.

A better way of repairing a lining at the melting zone is to put in a false lining over the old lining. This is done by putting on a layer of rather thin plastic daubing over the old lining and pressing a split fire-brick into the daubing with the flat side against the lining. The brick are pressed into the daubing close together almost as soon as it is put on, and all the joints are filled up and the surface made smooth. A lining may be put in a cupola in this manner all the way around and to any height desired, or only thin places may be repaired, which is done without forming humps in the lining that interfere with the melting.

A split brick is an ordinary fire-brick, only 1 inch thick in place of 2 inches, and is now made by all the leading fire-brick manufacturers. We believe we were the first to repair a lining in this way, some 20 years ago. The split brick could not then be procured from fire-brick manufacturers, and they were made by splitting the regular sized brick with a sharp chisel after carefully nicking them all around. When the regular split brick cannot be procured they may be made in this way. Most of the new brick split very readily and true, but bats from old lining generally spall off and are difficult to split. A lining of split brick can be put in almost as rapidly as the cupola can be shaped with daubing alone. The diameter of the cupola is not reduced to the same extent as with a section of new lining put in in the regular way, and the best melting shape for the cupola is maintained with only a reduction in the diameter of from 3 to 4 inches. This lining, when put in with a good daubing well mixed, lasts as long as an equal thickness of lining put in in the regular way; and it can be put in at a great deal less expense for labor and material. It is, however, worthless if put in with a poor, non-adhesive and unrefractory daubing.

CHAPTER VI.

EXPERIMENTS IN MELTING.

IN visiting different foundries years ago, when the management of cupolas was not so well understood as at the present time, we found that there were many different opinions held by foundrymen as to the point in a cupola at which the melting of iron actually took place. Some foundrymen claimed that melting was done from the tuyeres to the charging door, others that iron was only melted in front of the tuyeres by the blast and flame, on a similar principle to melting in an air furnace, and still others claimed that iron was only melted at a short distance above the tuyeres. These various opinions led to different ways of charging or loading cupolas. In some foundries one or two hundred-weight of iron were put in on the bed, then one or two shovelfuls of fuel, then more iron and fuel in the same proportion, until the cupola was filled or loaded to the charging door. This way of charging mixed the fuel and iron together, and cupolas were charged in this way to melt from the tuyeres to the charging door. In other foundries from five to twenty hundred-weight of iron were placed on the bed and a layer or charge of fuel placed upon it to separate it from a second charge of iron of a similar weight; which was again covered with a second charge of fuel to separate it from the third charge of iron, until the cupola was in this way filled. This charging was done upon the theory that a cupola only melted at a short distance above the tuyeres. Foundrymen who were of the opinion that the iron was melted by the flame and blast charged their cupolas in a similar way, but made the charges of iron light and those of fuel heavier, using an extravagant amount of fuel for each heat.

To learn definitely at what point iron was really melted in a cupola, and also to ascertain something in reference to a number of other points in melting, as to which we had found there was a wide difference of opinion among foundrymen, we constructed a small cupola with a light sheet-iron casing and a thin lining, through which tuyere and other holes could be easily cut and closed when not required. This cupola we connected with a Sturtevant fan placed at a short distance from the cupola. The fan was entirely too large for the size of the cupola, but it was arranged to regulate the volume of blast supplied by increasing or decreasing the number of the revolutions. On the blast pipe, near the cupola, we placed a very accurate steel spring air-gauge to ascertain the exact pressure of blast in each experimental heat. The cupola was eighteen inches diameter inside the lining, and we first put in two round tuyeres of four inches diameter and placed them on opposite sides of the cupola, twenty-four inches above the bottom.

The first experiments made in melting in this cupola were for the purpose of learning at what point in a cupola iron melted, and at what point it melted first. To ascertain these facts we procured a number of small bars of No. 1 soft pig iron and placed ten of them across each other in the cupola, six inches apart from center to center, and fastened the ends of each pig in the lining so that they could not settle with the fuel as it burned away. At the ends of each pig we removed the brick lining and filled in the space between the ends of the pig and casing with fire-clay, and through this clay and the casing made a small hole through which the heat and blast would escape as soon as the iron melted and fell out of the lining. The first bar of iron was placed three inches above the bottom, and the others at intervals of six inches. When they had all been put in place the bottom door was put up, a sand bottom put in and the fire started in the usual way. As soon as the fire was burned up the cupola was filled with coke to the charging door, which was six feet from the bottom, and the blast put on. The fan was run very slowly during the heat and

the air-gauge showed less than one ounce pressure of blast in the pipe at any time during the heat, and the greater part of the time showed no pressure at all. We attributed the light pressure of blast to the fact that no other iron was placed in the cupola but the ten bars of pig iron, and the blast escaped freely through the fuel. The pressure of blast would probably have been greater if the fuel had been heavily weighted down with charges of iron closely packed in the cupola. The tap hole was made small and not closed during the heat, and the iron permitted to run out as fast as melted and a note made of the time at which it melted. Iron first appeared at the tap hole in three minutes after the blast was put on, and continued to flow freely until one pig was melted, as was shown by the weight of the iron when cold. The pig melted was the one placed six inches above the top of the tuyeres, as indicated by the escape of the blast from the holes placed in the casing at each end of the pig. After this pig had melted there was a cessation in the flow of iron from the tap hole for about three minutes, when it began to flow again and flowed freely until another pig was melted. The pig melted this time was the one placed twelve inches above the tuyeres, as indicated by the small holes at the ends of the pig. There was then a dribbling of iron from the tap hole for a short time, when it ceased altogether; but the blast was kept on until the appearance of the flame at the charging door indicated that the fuel was all burned up, and the bottom was then dropped.

When the cupola cooled off it was found that none of the four bars placed below the tuyeres had been melted or bent, and they showed no indications of having been subjected to an intense heat. The fifth bar, however, showed such indications and was partly melted, but was still in place. This bar was placed across the cupola almost on a level with the tuyeres, and at a point where the blast from the two tuyeres met in the center of the cupola. The iron that dribbled from the tap hole, as mentioned above, was melted from this bar. The sixth and seventh bars had melted as indicated by the escape

of blast from the small holes in the casing at the ends of each bar and were entirely gone. The eighth bar was badly bent and showed evidence of having been subjected to an intense heat, but was not melted at all. The ninth and tenth bars were in place and showed less signs of having been highly heated than the eighth bar. The iron from the two pigs melted was a shade harder than when in the pig, and the iron from the pig partly melted was two or three shades harder, showing that iron melted very slowly or burned off was hardened in the process, and we afterward found this to be correct in the regular way of charging a cupola. This heat showed that with a light blast the cupola melted only from about the top of the tuyeres to twelve or fourteen inches above the tuyeres.

For the next heat the two bars melted out were replaced by new ones, and the bent one was also removed and replaced by a straight one. The cupola was made up and fired in the same manner as in the former heat, and filled with fuel to the charging door. The same sized tuyeres were used and the speed of the fan increased so as to give a four-ounce pressure of blast in the blast pipe, as indicated by the air-gauge. In this heat, as in the former one, the iron placed below the tuyeres did not melt, and the bars placed above the tuyeres at different heights melted at different times. The sixth bar placed six inches above the top of the tuyeres was the first to melt. Then in a few minutes later the seventh bar melted, and still a few minutes later the eighth bar, placed eighteen inches above the tuyeres. These three bars melted rapidly after they began, and were melted within a few minutes of each other. The iron from the first bar melted was a little dull, but the iron from the other bars was very hot. There was no dribbling of iron from the tap hole after the pigs were melted, as in the former heat, and one pig placed higher in the cupola, was melted in this heat. There was no fuel placed in the cupola after the blast was put on and when the fuel required to fill it to the charging door, or about twelve inches above the top of the last pig, was all burned out, the bottom was dropped, and the cupola permitted to

cool off. When we went in to examine it, it was found that the fifth bar, placed opposite the tuyeres, which had to some extent melted in the former heat, showed no change and had not been subjected to so high a temperature in this heat. The sixth, seventh and eighth bars had been melted entirely out, as indicated by the escape of blast through the small holes in the casing at the ends of each bar. The ninth bar was in place, slightly bent, and showed indications of having been subjected to a higher temperature than during the former heat. The tenth bar at that point showed no change from increase of heat. From this heat we learned that directly in front of the tuyeres and just above them, the heat was decreased by a stronger or greater volume of blast, and the melting temperature was raised to a higher level in the cupola; for the heat had been decreased at the fifth bar to an extent that prevented it from melting at all, and increased at the eighth bar to so great an extent that it was readily melted.

For the next heat we arranged the bars and cupola in exactly the same way, and increased the speed of the fan to give an eight ounce pressure, as shown by the air-gauge. The melting in this heat was practically the same as in the last one just described. We had anticipated that the melting temperature would be raised to a higher level in the cupola by the increase of blast, and were very much disappointed when it was found that the results were the same as with a four-ounce pressure of blast. After thinking the matter over for several days, it occurred to us to put on the blast without charging the cupola and test the air-gauge with different speeds of the fan. In doing this it was found that with the fan running at the same speed that showed eight ounces pressure on the gauge when the cupola was in blast, the gauge showed six ounces pressure when the cupola was not in blast. We at once concluded that the tuyeres were too small to permit so great a volume of blast to pass through them, and the pressure of blast shown by the gauge was due to the smallness of the tuyeres, and not to the resistance offered to the blast by the stock in the cupola.

Since making this discovery, we have seen a great many cupolas when in blast show a high pressure of blast on the air-gauge when the pressure was almost wholly due to the size of the tuyeres and very little blast was going into the cupola.

After making the discovery that the tuyeres were too small to admit to the cupola the volume of blast produced by the fan, we placed two tuyeres in the cupola, four by six inches, laid flat. The tuyeres were made of this shape to increase the tuyere-area and at the same time neither raise the top of the tuyere nor lower the bottom, so that comparison of results in melting could be made with the former heat without rearranging the bars placed in the cupola.

For the next heat we replaced the bars, melted out and made up, and charged the cupola as before and ran the fan at the same speed that had shown eight ounces pressure on the gauge with the small tuyeres. The result was that the gauge only showed a pressure of four ounces of blast. The sixth bar placed six inches above the tuyeres, which had been the first to melt in former heats, was not melted at all in this heat, and the seventh, eighth and ninth bars were melted in the rotation named at about the same time apart as in former heats. The tenth bar was not melted, and none of the bars below the tuyeres were melted. The iron from the ninth bar, which was placed twenty-four inches above the tuyeres and was the last to melt, was accompanied by a good deal of slag as it flowed from the tap hole, and the iron when cold was white hard, although it was No. 1 soft pig iron when placed in the cupola. The slag and hardness of the iron we attribute to the strong or large volume of blast used in this heat, as there had been no hardening of the last pig melted in former heats with a lighter blast. But this pig had remained in the cupola unmelted during the three former heats and been subjected to the heat of the cupola, and it was afterwards found that the hardness and slag were due to the roasting and burning of the iron in these heats, and not to the strong blast as at first supposed. In this heat the melting temperature was raised to a higher level in the cupola, but only three bars were melted as before at a lower level.

For the next heat we placed two more tuyeres in the cupola at the same level and of the same size as those used in the last heat, and arranged the cupola as before with a view to melting the tenth or top bar. The speed of the fan was the same as in the last heat, in which the gauge showed four ounces pressure of blast with two tuyeres. In this heat with double the tuyere-area, the gauge indicated a pressure of about one ounce, showing that the tuyere was still too small in the last heat to permit the blast to escape freely from the blast-pipe into the cupola. We were standing near the spout during this heat with our watch and note-book in hand, waiting to time the first appearance of iron at the tap hole and thinking it was a long time in coming down, when our assistant reported there was no flame or heat at the charging door, and the fire must have gone out. We at once examined the charging door and found that nothing but cold air was coming up. We then stopped the fan and removed the tuyere pipes, and found there was no fire in the cupola at the tuyeres. The front was then removed and plenty of fire was found in the bottom of the cupola, which immediately brightened up. The fire had been well-burned up as we supposed, above the tuyeres, before the blast was put on, and it had not been on more than fifteen minutes. We were not satisfied with the results in this heat, and as the fire showed signs of burning up when the front was out and the tuyeres were open, it was determined to let it burn up and try it again with the strong blast. After the fire had burned up until there was a good fire at the tuyeres and we were quite sure the fuel was on fire to eighteen or twenty inches above the tuyeres, we put on the same volume of blast as before and watched the results at the charging door. At first the blast came up through the fuel quite hot, but the temperature gradually decreased until it became cold, and it was evident that the large volume of blast had put out the fire, and this was found to be the case when the tuyere pipes were removed.

When the bottom was dropped there was fire in the bottom of the cupola, and the coke around the tuyeres showed that it

had been heated, but the coke in the upper part of the cupola showed no signs of having been to any extent heated.

The fuel used in this heat was hard Connelsville coke in large pieces. Large cavities were formed under the bars of iron supported by the lining in charging. The coke was not weighted down with iron in the cupola, and the blast escaped freely through the crevices between the large pieces.

We afterward made a heat in this cupola with the same tuyeres and blast, and charged the cupola in the regular way. The iron melted in this heat was pig and small scrap, that packed close in the charges and did not permit the blast freely to escape through the fuel. The gauge in this heat showed a blast pressure of three ounces and the fire was not blown out, but the cupola did not melt so well as with a less volume of blast, and the iron was harder.

These heats showed that iron is not melted in a cupola by the blast and flame of the fuel; for if it were, the bars directly in front and over the tuyeres, where the blast was the strongest, would have been melted first and been the only ones melted. But the one in front of the tuyeres was not melted by a mild blast, and the one just over the tuyeres was not melted by a strong blast.

The failure of the sixth and tenth bars to melt in the same heat, showed that iron is not melted in a cupola all the way from the tuyeres to the charging door, as it was years ago supposed to do by most foundrymen, when the fuel and iron were mixed in the cupola in place of being put in in separate charges, as is now commonly done.

The raising of the melting temperature to a higher level in the cupola by increasing the blast, showed that there is a certain limited melting space or zone in a cupola in which iron melts, and that this melting zone may be raised or lowered by an increase or decrease of the volume of blast. However, the depth of the melting zone is not increased by a strong blast, but the zone is placed higher in the cupola. It was also shown that iron cannot be melted in a cupola outside of this zone, either

above or below it, for the bars placed above and below it were not melted with either a light or a strong blast. The putting out of the fire in the cupola by a very large volume of blast and the subsequent poor melting done with a large volume of blast when the cupola was charged in the regular way, showed that too much blast may be given to a cupola and the iron thereby injured.

FUEL UNDER THE TUYERES.

In the first two heats it was noticed that considerable coke fell from the cupola when the bottom was dropped, although the indications at the charging door were that all the fuel in the cupola had been burned up. We determined to learn where this coke came from, and in the third heat we kept the blast on until the cupola was well cooled off, and we then turned a stream of water into it from a hose until the fire was out and the cupola cold. The ashes and cinder were then removed from the tuyeres, and it was found that there was no fuel above them except a few small pieces that had been buried in the ashes and cinder. The bottom was let down gradually, and the cupola found to be filled with coke and very little ashes from the bottom to the tuyeres.

The coke when examined showed that it had been heated through, and was soft and spongy like gas-house coke, and totally unfit for melting purposes. When put into the cupola it was hard Connelsville coke. We thought that all the ash found in the coke was made by the burning up of the bed before the blast was put on, and that the coke was not consumed at all after the blast was put on; but we had no means of accurately determining this point. We afterward put a number of peep holes in the cupola at different points below the tuyeres to observe the action of the fuel at this point. The holes were arranged with double slides, the inner one with mica and the outer one with glass. The mica was not affected by the heat, and could be withdrawn for a few minutes and the action of the fuel observed through the glass without the escape of the blast.

Through these openings it was observed that the fuel was always at a white heat just before the blast was put on, but after the blast had been on for a short time it became a dull red and remained so throughout the heat. Molten iron could be seen falling through the fuel in drops and small streams. But the fuel was never seen to undergo any change or to settle down as it would do if it were burning away. From these observations it was concluded that the fuel placed under the tuyeres was not consumed during the time the blast was on, and that the only fuel burned in this part of the cupola was that consumed in lighting up before the front was closed.

LOW TUYERES.

After the failure to melt with the four large tuyeres, we placed two tuyeres, four by six inches, in the cupola, on opposite sides, three inches from the bottom or one inch above the sand bottom. The bars were placed in the cupola as before and the cupola filled with coke to the charging door, and a four-ounce pressure of blast put on, the same as in the heat with these two tuyeres when placed at a higher level, namely, twenty-four inches above the bottom. In this heat three bars were melted, but the quantity of slag that flowed from the tap hole with the iron was so great that we did not know where it came from, and we were so afraid of the tuyeres being filled with slag or iron, that we failed to note the time the iron melted or the points we were looking for; but something else was learned.

We at first thought the slag came from tuyeres being placed so near the sand bottom, and when the coke with which the cupola had been filled was burned out and the heat over, we took out the front and raked out the fuel and ash in place of dropping the bottom, to see how badly the sand bottom had been cut up by the blast. It was found that it had not been cut at all and was as perfect as when put in and nicely glazed. The lining had not been burned out to any greater extent than in former heats when there was no slag, and we were at a loss to

imagine where the slag came from. But when the iron that had been melted in this heat was examined, it was found where the slag came from. All the pigs melted were placed in the cupola at the beginning of the experiments and had remained there unmelted under the tuyeres during a number of heats, and the iron had been burned by the fire in the bottom of the cupola when lighting up, and during the heats. When placed in the cupola this iron was No. 1 soft pig, but when melted it was as hard and brittle as glass, and fully two-thirds of it had been burned up and when melted converted into slag.

The results of this heat were so unsatisfactory that we replaced the bars melted out, and repeated the experiment. The results in this heat were practically the same as in the heat with the tuyeres placed twenty-four inches above the bottom. Three bars placed six, twelve and eighteen inches above the tuyeres were melted in the same rotation and in about the same time. There was no trouble with slag, and the cupola melted equally as well as when the tuyeres were placed twenty-four inches above the bottom.

MELTING ZONE.

These heats established the fact that there exists a melting zone in a cupola when in blast, and that iron cannot be melted outside of this zone. The location of a melting zone in a cupola is determined by the tuyeres and the distance or height of the zone above the tuyeres by the volume of blast, and its depth by the volume of blast and charging of the cupola. In these heats the melting zone was lowered in the cupola twenty-one inches by lowering the tuyeres to that extent without making any change in the character of the melting, and it could have been raised the same distance without making any difference in the melting. The zone was raised from one level to another above the tuyeres by increasing the volume of blast. In the first heat, with a light blast, a bar of iron placed on a level with the tuyeres was partly melted, and one placed eighteen inches above the tuyeres was highly heated and almost ready to melt. Bars

placed above and below these two bars were very little affected by the heat, and bars between them were melted, showing that these two bars were on the edges of the melting zone, and the zone had a depth of about eighteen inches. In the next heat, with a larger volume of blast, the bar placed on a level with the tuyeres was not melted at all, showing that it was outside of the melting zone and the latter had been raised by the stronger blast. In the next heat, with a still larger volume of blast, a bar placed six inches above the tuyeres was not melted, showing that the zone had again been raised by the volume of blast. In each of these heats a bar placed higher in the cupola was melted, showing that the depth of the zone remained about eighteen inches and the entire zone was raised to a higher level. We attributed the raising of the zone by increasing the volume of blast to the fact that the blast was cold when it entered the cupola, and it was necessary for the air to pass through a certain amount of heated fuel and become heated to a certain degree before its oxygen entered freely into combination with the carbon of the fuel to produce an intense heat; and the greater the volume of cold air, the greater the amount of heated fuel it had to pass through before it became heated. With a hot blast this would not have been necessary, and the zone would probably have remained stationary and its depth been increased. In heats that were afterward made in this cupola with fuel and iron charged in the regular way, we found that the location and depth of the zone were somewhat changed by the weighting down of the fuel with heavy charges of iron. These tests were made by carefully measuring the fuel in the cupola from the charging door after the fire was burned up and the fuel settled, and we took care to have the fuel burned as nearly alike in each heat as possible, and to have the fire show through the top of the bed before iron was charged.

In a former heat, with only bars in the cupola, a bar was melted which was placed twenty-four inches above the tuyeres. We placed a bed of that height in the cupola and put a charge of three hundred weight of iron on it, and turned on the same

blast with which we melted the bar at that height. The blast was on for half an hour before any iron melted, and the melting was very slow until about half the charge was melted, when it began to melt faster. This indicated that the iron was placed above the melting zone and supported there by the fuel, and the fuel had to be burned away before the iron was permitted to come within the zone by the settling of the stock.

In the next heat we placed the top of the bed two inches lower, and in each subsequent heat two inches lower, until it was lowered to ten inches above the tuyeres, and made the charges of iron the same, or three hundred weight.

With a twenty-two inch bed, iron came down in twenty minutes and was hot, but melted slowly throughout the heat.

With a twenty-inch bed, iron came down in ten minutes, melted *hot* and faster than in previous heats.

With an eighteen-inch bed, iron came down in five minutes, and melted fast and hot throughout the heat.

With a sixteen-inch bed, iron came down in four minutes, melted hot and fast at first, but toward the latter end of the charge the iron was a little dull, and as each charge melted the first part of it was hot and the latter part dull.

With a fourteen-inch bed, iron came down in four minutes. Melted fast, but was too dull for light work.

With a twelve-inch bed the iron was very dull, and with a ten-inch bed it was so dull that it could not be used for general foundry work. With a light blast and low melting zone, the iron in these two heats would probably have been hot.

In these experiments we obtained the best general results with a bed of eighteen to twenty inches, and we adopted this bed for further experiments.

Our next experiments were to learn the depth of the melting zone in practical melting, and the amount of iron that should be placed in each charge to melt iron of an even temperature throughout a heat. In these experiments we made the charges of fuel placed between the charges of iron at a ratio of one pound of fuel to ten pounds of iron.

For the first heat we put in a bed of eighteen inches, on this bed four cwt. of iron, on this iron forty pounds of coke, on the coke four cwt. of iron, and so on until the heat was all charged. The blast was the same as before, four ounces pressure with two large tuyeres. In this heat the iron melted hot and fast, and of an even temperature throughout the heat.

For the next heat we made the charges of iron five cwt., and charges of coke fifty pounds. The results in melting were practically the same in this heat as in the former one.

For the next heat we made the charges of iron six cwt., and coke sixty pounds. In this heat there was a slight change in the temperature of the iron as the last of each charge melted.

For the next heat the charges were, of iron seven cwt., and coke seventy pounds. The iron in this heat was a little dull when the last of each charge melted, and hot when the first of the next charge melted, making the iron of a very uneven temperature throughout the heat. How often have we seen cupolas melt in this way. In fact it is a common thing in the majority of machine and jobbing foundries for a cupola to melt iron of an uneven temperature, and moulders may be seen almost every heat standing round the cupola watching their chance to catch a ladle of hot iron to pour a light pulley or other piece of light work. The uneven melting is never attributed to improper charging, but to the mysterious working of the cupola.

For the next heat the charges were, of iron eight hundred weight, and coke eighty pounds. In this heat the iron was hot until the last of the first charge, when it became dull. The first of the second charge was hot, but it soon became dull, and before the charge was all melted it was very dull. At the beginning of the third charge the iron livened up a little, but soon became too dull to pour the work and had to be put into the pig bed. In this heat we used exactly the same percentage of fuel (one to ten) between the charges as in the former heats, which should have raised the top of the bed to its former height after melting a charge of iron; but it did not do so, as shown by the melting, and the iron became duller as the melting of

the heat progressed. Had another charge of iron been put in, it probably would not have melted at all. The failure of the cupola to melt well in the latter part of the heat was not due to the heat being too large for the cupola, for we afterwards melted heats double the size of this one in the same cupola, and had hot iron to the end of the heat. The top of the bed was reduced to a lower level in this heat in melting the heavier charges of iron, and the fuel in the bed must have burned away more rapidly when the bed was low, or the charges of fuel would have restored it to its former height, as with the light charges of iron. We tried to determine this point more accurately by placing a vertical slot in the cupola at the melting zone in order to observe the settling of the charges, but the heat was so intense at this point that the heat could not be confined within the cupola, and the slot had to be closed up.

In these experiments the most even melting was done with four and five hundred-weight charges. With these charges the fuel kept the top of the bed at a proper height in the melting zone, while with heavier charges it became lower after the melting of each charge, until it became too low to make hot iron, and if the charges had been continued, too low to melt at all. We afterward tried a number of heats with a twenty-inch bed and six hundred-weight charges, and did good melting. With a twenty-four inch bed and six hundred-weight charge the melting was even, but slow.

By the experiments in this cupola it was found that it was necessary to pass the blast through a certain amount of heated fuel before a melting zone was formed in a cupola, and that the amount of heated fuel required for the blast to pass through depended upon the volume of the latter. This heated fuel must be above the tuyeres, for the blast passes upward from the tuyeres, and the melting zone is located at a point dependent upon the amount of heated fuel the blast must pass through before it becomes heated and forms the zone. The blast does not pass downward from the tuyeres except when it may be permitted to escape from the tap or slag hole, and fuel placed

below the tuyeres takes no part in the melting of iron in a cupola. When the tuyeres are placed high, the fuel grows deader as the heat progresses and becomes a dull cherry red. We believe the fire would go out in this part of a cupola in a long heat were it not for the molten iron dropping through the fuel, and the occasional escape of blast from the tap and slag holes.

Iron melted high in a cupola is made dull by passing through a large amount of fuel below the tuyeres. With the tuyeres in this cupola placed three feet above the bottom and iron properly charged to make hot iron, it was found impossible to get hot iron at the tap hole for light work. This was undoubtedly due to the iron being chilled in its descent through the fuel under the tuyeres, for the same charging and blast produced hot iron with low tuyeres. The amount of fuel under the tuyeres makes no difference in the location of the zone, and it is the same distance above the tuyeres with high tuyeres as with low ones, when the blast is the same. No iron is melted outside of the zone, and fuel placed above the zone takes no part in melting until it descends into the zone. If too large a quantity of fuel is placed in a bed, the iron charged upon the bed is placed above the zone and cannot be melted until fuel in the zone is burned away and the iron settles into the zone, and iron is a long time in melting after the blast is put on. If too great a quantity of fuel is placed in the charges, the top of the bed is raised above the zone after the melting of each charge of iron, and fuel must again be burned away before the iron can settle into the zone to be melted, and there is a stoppage in melting at the end of each charge of iron. If the charge of iron is made too heavy, the bed is lowered to so great an extent in melting the charge that the top of the bed is not raised to the top of the zone by the charge of fuel; and as each succeeding charge is melted, the bed sinks lower until it gets near the bottom of the zone and iron melts dull, or sinks below the bottom of the zone, and melting ceases. Scarcely any two cupolas have the same tuyere area or receive the same volume of blast, and for this reason

scarcely any two cupolas can be charged exactly alike. To do good melting in a cupola it is necessary for the melter to vary the amount of fuel in the bed until he finds the top of the melting zone, and to vary the charges of fuel until he finds the amount of fuel that will raise the bed to the top of the zone after melting a charge of iron. He must vary the weight of the charges of iron until he finds the amount of iron that can be melted in a charge without reducing the bed too low to be properly restored by a charge of fuel.

After twenty years' active experience in melting in different cupolas, the above are the only practical instructions we can give for charging and managing a cupola; and no table of charges for cupolas of different sizes, with different tuyere-area and volume of blast, would be of any practical value to a melter. Fuel placed in a cupola above the zone to replenish the bed is heated by the heat escaping from the zone, and prepared for combustion in the latter, and iron placed above the zone to be melted is heated and prepared for melting in it, and the more fuel and iron brought into a cupola at one time the greater the amount of heat utilized. And the charging door should be placed at a sufficient height to admit of a large amount of stock, or the entire heat, being put into the cupola before the blast is put on.

The melting zone is developed above the tuyeres by permitting the blast or carbonic oxide to escape upward after passing through the zone, and it may be developed below the tuyeres by permitting it to escape downward. A cupola has been constructed with the tuyeres placed near the top, and provision made for the escape of the blast through flues arranged near the bottom of the cupola. It was hoped by this plan that all the heat produced by the fuel would be utilized in melting, and the entire heat placed in a cupola melted very quickly and economically. But these hopes were not realized, for the depth of the melting zone was not increased by being below the tuyeres, but remained the same as above the tuyeres. Iron could not be melted outside of the zone, and the cupola was a failure.

MELTING WITH COAL.

All the experiments just described were made with Connellsville coke, but we also made a number of similar ones in this same cupola with anthracite coal. In these experiments it was found that the melting zone was not so high above the tuyeres with the same volume of blast as with coke, nor was the depth of the zone so great, but the coal did not burn away so rapidly in the zone as coke and heavier charges of iron could be melted. In these experiments the best results were obtained with a bed of about fourteen inches above the tuyeres and charges of coal of one to eight, and charges of iron from one-half to two-thirds heavier than with coke. An opinion prevails among foundrymen that the tuyeres in a cupola must be especially adapted for coal or coke, or these fuels cannot be used. In these experiments we used the same tuyeres as with coke, placed them at the same heights, and found no difficulty in melting with them; and iron may be melted in any cupola with either coal or coke, if charged to suit the fuel and tuyeres, without any change in shape or arrangement of tuyeres.

SOFTENING HARD IRON.

In experimenting with iron in a crucible, we found that the hardest iron could be softened by melting it, or subjecting it to a prolonged heat in a closed crucible with charcoal. We thought the same results might be obtained in a cupola by passing molten iron through charcoal in its descent from the melting zone to the bottom of the cupola. It had been found that fuel below the tuyeres was not consumed during a heat, and we decided to try permitting the iron after melting to drop through a bed of charcoal under the tuyeres. The tuyeres were placed twenty-four inches above the bottom and the cupola was filled with charcoal to the tuyeres, and above the tuyeres coke to do the melting was placed. We were afraid the charcoal would all be burned up before the coke above the tuyeres was ready for charging, and to prevent this we put in a wood fire to dry the bottom and warm the cupola. When this was burned out we

filled the cupola with charcoal to the tuyeres, put in shavings and wood, and lit the fire at the tuyeres above the charcoal. The charcoal was only burned a little on top when the coke was ready for charging, and not on fire at all in the bottom of the cupola. When the cupola was ready for charging we put in one charge of five cwt. of hard pig and scrap, and put on the blast. The iron melted hot, but in its descent through the charcoal to the bottom of the cupola was cooled to such an extent that it would scarcely run from the tap hole, and the heat was a failure. This was not the only failure in our experimental melting, and we are afraid if we attempted to write up all our experimental heats more failures than successes would be recorded. Experiments in a cupola are not always a success, no matter how much care may be taken in making them. Experimenters generally report only their successful experiments, but if they would report their failures also, they would give much valuable information and save other experimenters much time and expense in going over the same ground.

For the next heat we placed shavings over the bottom, filled the cupola with charcoal to the tuyeres, and put shavings and wood on top of the charcoal for lighting the coke. There was a great deal of trouble in getting the two fires to burn at the same time, and the results were not at all satisfactory.

For the next heat we filled the cupola with charcoal to a short distance above the tuyeres to allow for burning away, and settling, and lit the fire from the front in the ordinary way, and as soon as it was burned up to the tuyeres put in the front to shut off the draught at the bottom. This worked very well, and we found we had a good bed of hot charcoal up to the tuyeres when the cupola was ready for charging. On the bed of coke was placed a charge of five cwt. of pig and scrap, all white hard, and the blast put on. The charcoal bed did not appear to burn away at all during the heat, and the iron melted well and came down hot. When tapped almost as fast as melted, the iron was very little softened by the charcoal. But when allowed to remain in the cupola for some time after melting, it was

softened to the extent of becoming a mottled iron when run into pigs or heavy work. But when held in the cupola for a sufficient length of time to soften it to this extent, the iron became very dull and not fit to run light work. This experiment was repeated a number of times with different grades of hard iron, but we never found any marked change in the iron when tapped almost as fast as melted and hot. When held in the cupola a sufficient length of time to soften it to a limited extent, it was too dull to run light work, for the flowing properties of the iron were not to any extent increased by the charcoal. As there is no difficulty in making mixtures of iron soft enough for heavy work into which dull iron can be poured, we could see no advantage in using charcoal in this way.

TIME FOR CHARGING.

There is a wide difference of opinion among foundrymen as to the proper time for charging iron on the bed and putting on the blast after charging. Some claim that if iron is charged several hours before the blast is put on, fuel in the bed is burned up and the heat is wasted, and others claim that heat is wasted by putting on the blast as soon as iron is charged. In some foundries the cupola is filled with fuel and iron to the charging door before lighting the fire. In others, iron is charged after the fire is burned up and permitted to remain in the cupola two or three hours before the blast is put on, and in some foundries the blast is put on as soon as charging of iron begins.

We made a number of experiments in the heats just described to ascertain the proper time for charging and putting on the blast after charging. Iron charged before the fire was lit was very uncertain as to the time at which it melted after the blast was put on. In some heats it melted in five minutes and in others in thirty minutes.

Iron charged before the fire was burned through the bed was a long time in melting after the blast was put on, and the time of melting was very uncertain; in some heats it melted in ten

minutes, and in others not for thirty minutes. Iron charged after the bed was burned through and the heavy smoke burned off, melted sooner after the blast was on and was more regular in time of melting, and generally melted in ten minutes when the bed was of a proper height.

Iron charged two or three hours before the blast was put on, melted in from three to five minutes after it was put on.

Iron charged and the blast put on as soon as charging began, melted in from fifteen to twenty minutes.

In these heats it was found that time and power to run the blower were saved by charging the iron two or three hours before putting on the blast, for iron melted in from three to five minutes after the blast was on, and melted equally as fast during the heat as when the blast was put on soon after the iron was charged. We do not think that any fuel was wasted by this manner of charging, for we shut off the draught from the bottom of the cupola by putting in the front and closing all the tuyeres but one as soon as the bed was ready for charging. The bed burned very little after the front was put in, and the heat that arose from it was utilized in heating the first charge of iron preparatory to melting, or iron would not have melted in less time than when the blast was put on as soon as the iron was charged. There is great risk in charging iron before the fire is lit or has burned up, for the fire may go out or not burn up evenly, and we prefer to have the bed burned through before charging the iron.

DEVICES FOR RAISING THE BOTTOM DOORS.

A number of devices have been used for raising the bottom doors of cupolas into place, and thus avoiding the trouble and labor of raising them by hand. One of the oldest of these devices is a long bar, one end of which is bolted to the under side of the door, on the other end is cast a weight or ball almost sufficient to balance the door upon its hinges when raised. When the door is down the bar stands up alongside of the cupola, and when it is desired to raise the door the bar and weight are swung downward. As the weight descends the

door is balanced upon its hinges and swings up into place, where it is supported by a prop or other support. This device, when properly arranged and in good order, raises the door very easily and quickly into place, but it is continually getting out of order. The sudden dropping of the door in dumping and the consequent sudden upward jerk given to the heavy weight on the end of the bar, frequently breaks the bar near the end attached to the door or breaks the bolts by which the bar is attached to the door, and the door is sometimes broken by the bar. For these reasons this device is very little used.

Another device, and probably the best one for raising heavy doors, is to cast large lugs with a large hole in them, on the bottom and the door, and put in an inch and a half shaft of a sufficient length to have one end extend out a few inches beyond the edge of the bottom plate. The door is keyed fast upon the shaft, and the shaft turns in the lugs upon the bottom when the door is raised or dropped. An arm or crank is placed upon the end of the shaft, pointing in the same direction from the shaft as the door. When the door is down the arm hangs down alongside of the iron post or column supporting the cupola and is out of the way in removing the dump, and when the door is up the arm is up alongside of the bottom plate, out of the way of putting in the bottom props. The door is raised by a pair of endless chain pulley blocks attached to the under side of the scaffold floor at the top and the end of the arm at the bottom, and it is only necessary to draw up the arm with the chain to raise the door into place. This is one of the best devices we have seen for raising heavy doors.

Another one, equally good for small doors and less expensive, is to make the end of the shaft square and raise the door by hand with a bar or wrench five or six feet long, placed upon the end of the shaft. The bar is placed upon the shaft in an upright position, and by drawing down the end of the bar the door is swung up into place by the rotation of the shaft on to which it is keyed. When the door is in place the bar is removed from the end of the shaft, and is not at all in the way of handling the iron or managing the cupola.

CHAPTER VII.

EXAMPLES OF BAD MELTING.

MUCH has been written and published on melting by foundrymen and foundry foremen, who invariably give an account of rapid or economical melting done in their foundries; and it is seldom, if ever, that they publish accounts of poor melting or poor heats melted by bad management of their cupolas, or in their attempts to reach that perfection in melting of which they write. In giving points on melting for the benefit of others, it is as essential that causes of poor melting should be known that they may be avoided, as it is that those essential to good melting should be known that they may be practiced, and we therefore present a few instances of poor melting that have come under our observation in foundries we have visited, or in which we have been called upon to render assistance to overcome troubles in melting which were both annoying and expensive. In these instances we only give examples of what may occur in any foundry, and has occurred in many of them, where foundrymen are wholly dependent on their melters.

In 1878 we were engaged in making some experiments in melting with oil at the stove foundry of Perry & Co., Sing Sing, N. Y., at that time the largest stove works in the country. They were melting from 50 to 60 tons per day in four cupolas entirely with convict labor, and the results in melting were very unsatisfactory. Mr. Andrew Dickey, one of the firm and manager of the works, came to us one day after some very bad heats and asked us to take charge of their cupolas, set our own wages, and carry on our experiments at the same time. We took charge of their cupolas the following day and soon had their melting going along smoothly, but we did not like the job, and suggested to Mr. Dickey that we should teach a man

to melt who could take our place when we were ready to leave, and this he consented to do. A man was selected who proved an apt scholar, and we soon had him instructed in all the details of melting, and when we left he took full charge of the cupolas.

Two years later we received a despatch from Perry & Co., stating that they wished to see us as soon as possible at their Sing Sing Works. Upon our arrival there late in the afternoon, Mr. Dickey informed us they were having trouble with all their cupolas, and it had been impossible of late to get a good heat out of any of them, and wished us to see what was the trouble. We found the same man in charge whom we had two years previously taught to melt, and inquired of him what the trouble was. He said he did not know, that he had fully followed our instructions and had no trouble in melting until within the last few weeks; during this time the cupolas had been melting very badly. He had increased and decreased the fuel in the bed and charges, increased it in one part of the heat and decreased it in another, varied the amount of iron on the bed and in the charges, but had been unable to locate the trouble. We asked him to describe how the cupolas melted, and he said they melted the first few tons, which was about the first two charges, fast and hot; after that the melting gradually grew slower until near the end of the heat, when melting almost ceased; the cupolas were so bunged up every heat that they could scarcely be dumped, and it was only after a great deal of labor with bars that a hole could be gotten through, so that they would cool off by the next morning. The iron was of an uneven temperature, frequently too dull for pouring and in some parts of the heat white hard, although nothing but soft iron had been charged. He thought the trouble must be in the blast—that old “no blast” story that foundrymen hear so often, when melters do not know how to manage a cupola and have to lay the blame on something. We informed him that the trouble could not be in the blast, or the cupolas would not have melted the first two charges fast and hot; that the trouble was the stock logged in,

THE CUPOLA FURNACE.

FIG. 22.

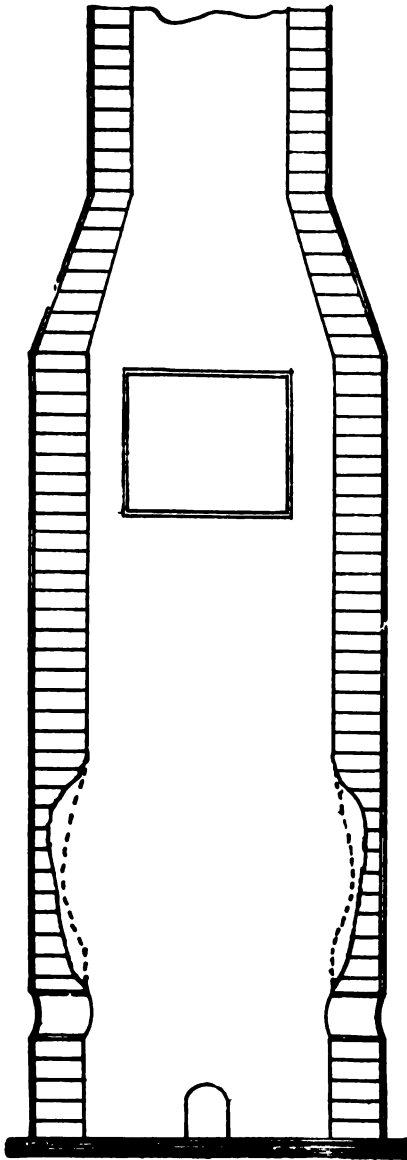

SECTIONAL VIEW LINING OUT OF SHAPE. NO. 3.

settled or settled unevenly after melting the first two charges, which was the cause of the uneven melting in the latter part of the heat, and he must have permitted the linings to get into a shape that produced this condition in the cupolas. He did not think this possible, for he had followed our directions for shaping a lining, but admitted that he frequently found pieces of unmelted pig and scrap in the cinder above the tuyeres when chipping out, which confirmed our theory, and we looked no further for the cause of poor melting.

The following morning the cupolas were almost closed up with cinder, slag and iron, and after a great deal of labor in breaking down and chipping out we found the linings in the shapes shown in Figs. 20 to 23.

Cupola No. 1 had not been lined for a long time, and the lining was burned away until it was very thin all the way up. This did not prevent the cupola melting, but should have made it melt faster; for as a cupola is enlarged in diameter by burning out of the lining its melting capacity increases; but in this case the melter had permitted the lining to become hollow around the cupola just above the tuyeres. When the stock settled, that on the outer edges lodged in this hollow, became chilled and threw the blast to the centre of the cupola. After a few tons had been melted the chilled stock over the tuyeres increased rapidly until the melting was restricted to an opening in the centre, which gradually closed up with the fan blast, and the longer the cupola was run the slower it melted, until melting ceased altogether.

In No. 2 the lining was not burned away to so great an extent as in No. 1, but the melter had permitted it as in No. 1 to become hollow over the tuyeres. He had been troubled with molten iron running into the tuyeres, and to prevent it doing so had built the lining out from 3 to 4 inches with daubing over each tuyere. This cupola like the others was 60 inches in diameter with six oval tuyeres each 4 by 12 inches laid flat. Over each of these tuyeres was a projecting hump 3 to 4 inches thick and 16 to 18 inches long; add to the thickness of these

THE CUPOLA FURNACE.

FIG. 23.

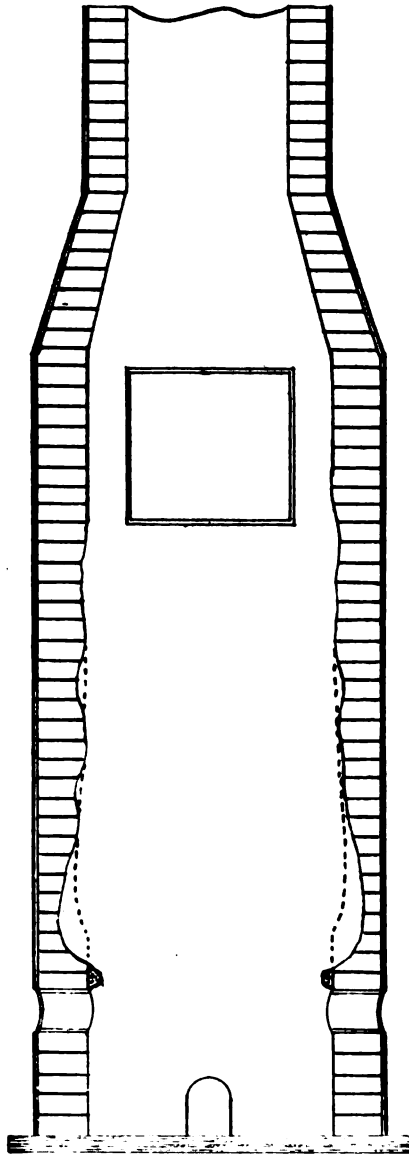

SECTIONAL VIEW OF LINING OUT OF SHAPE. NO. 4.

BAD MELTING AT A WEST TROY STOVE WORKS.

In 1882, we visited the foundry of Daniel E. Paris & Co., West Troy, N. Y., and while waiting for Mr. Paris, looked over the cupola. We found the lining in a condition indicating very poor melting and knew they were having some trouble with their iron. When Mr. Paris returned and learned who we were, he informed us that their foundry had recently burned down and they had moved into the present one, which had for some time before been idle. The boiler and engine were small and they were having some trouble in melting for want of power to drive a Sturtevant blower, which when run at a proper speed was large enough for the cupola. They were also endeavoring to melt up a lot of scrap from their recent fire, and had also procured some of the best brands of No. 1 Pennsylvania irons and Scotch pig to melt with it, but were having some hard castings. He wished to know if we could suggest anything to help them out until they could put in a new engine and boiler, and find some softer pig iron to work up the scraps, and he took us out to look over the works to see what change could be suggested.

We looked over the blower and machinery, which were only those employed in stove mounting, and then went into the engine and boiler room, where we found a good-sized engine and boiler, and decided that they were large enough to run the blower and all the machinery in the works at the same time. The engineer at once informed us that they were too small and he could not run any of the mounting machinery when the blast was on, or pump water into the boiler, without reducing the speed of the blower, and he had to fill the boiler and stop the engine for half an hour before putting on the blast, to get up steam. We then went into the foundry, where we found a well arranged cupola of fifty-four inches diameter inside the lining, and learned that they were melting about eight tons of iron each heat; that from four to four and a half hours were required to run off the heat, and they were melting seven pounds of iron to the pound of anthracite coal. The iron melted so

slowly that it was difficult to catch four hand-ladles full to pour off a *four up* before the first ladle-full was too dull to run the work, and the iron was sometimes so hard that the plate cracked when taken out of the sand or when knocking off the gates.

We then went upon the scaffold, where we found the coal when charged was not weighed, but measured in a basket and dumped from the basket into the cupola. We afterwards weighed a basket of coal filled as the melter generally filled it, and found it weighed almost twice as much as the melter stated, and with the extra weight of coal in the basket and the extra shovelfuls the melter said he threw in to fill up holes, we concluded that they were melting about three pounds of iron with one of coal, in place of seven to one as claimed by the melter. No slate was used in charging, sprows and gates were not weighed, but the weight estimated by counting the shovelfuls, and pig was weighed by counting the pieces, estimating four pieces to the hundred weight. The greater part of the coal, when dumped into the cupola from the basket, fell directly under the charging door, where it remained; and the greater part of the iron naturally went to the opposite side of the cupola, and this uneven charging naturally produced uneven melting.

We pointed out to Mr. Paris that his cupola lining was not glazed in front of the charging door, but was rough and jagged, as linings generally are in cupola stacks, which is an indication that too great a quantity of fuel is being consumed in melting and that by using less coal better melting would be done. He thought seven to one was very good melting and knew none of the foundries in Troy were doing any better, and that he thought iron could be melted sufficiently hot for their work with a greater ratio of iron to fuel than was being consumed in his cupola. But he was getting very poor results in melting, and after considerable talk he concluded to let us try a heat the following day with less fuel.

The following morning when we went round to have the

cupola prepared for a heat, we found the matter of less fuel had been talked over by the entire foundry force and by them condemned. They argued that dull iron had been melted with the quantity of fuel used, and could not be poured at all if less fuel were used. It is a curious fact that moulders working piece work and losing work every day from dull iron will object to a stranger, and any man whatever but the melter making any change in the management of the cupola, or as they term it, experimenting with the cupola. While getting the cupola ready for a heat, the moulders came to us at the cupola or in the yard, one after another, and asked us all kinds of questions about melting, and Mr. Paris came also and asked us if we were sure we could melt iron hot enough for their work with less fuel than they were using, also if we had ever done so before; and we found that we would have to be very careful what we said or did, or we would not be permitted to run off a heat.

The melter was an old hand, who had melted iron in a number of the foundries in Troy, and was considered good. He was very much opposed to having us do any better melting in the cupola than he had done without a new engine and boiler, which he declared must be put in before anything better could be done. He knew all about it, and to teach this man to melt with less fuel would only be a waste of time, for he would probably in less than a week drift back into the same old rut if not closely watched, and would condemn our way of managing a cupola. So we told Mr. Paris we could teach his foreman to melt in a few days so that he could oversee the work and teach a man to do it in case his melter was sick or quit, and that it would be much better for them than for us to show their melter how to work with less fuel. After consulting the foreman it was decided that we should teach the foreman, and he went on the scaffold with us. He had the cupola made up as we directed, sent to a store and purchased a new slate and arranged a system of mixing and charging the iron so that it would produce an even grade when melted, having had the

scales dug out of a pile of rubbish in a corner and cleaned up, and the iron and fuel placed conveniently for charging.

After everything had been arranged for the heat we had a little time to spare, and made it a point to see some of the leading moulders and explained to them that we had shaped the lining so that the cupola would melt faster and with a little less fuel than they had been using, and make hot iron. We also saw the engineer and informed him that we would charge the cupola in a way that it would demand less blast, and if he filled his boiler and had a good head of steam on just before putting on the blast, he could run all the machinery required for mounting when the blast was on. These explanations seemed to satisfy everybody, and the foreman was so enthusiastic in learning to melt that we had no further fear of being run out of the works, and were looked upon as the man who understood his business until the heat was all charged into the cupola, when the melter went into the foundry and said to the moulders: "Be jabbers yees will not pour off to-day boys, for that cupola will not make hot enough iron for yees with all the coal I was after putting in, and that man has left out half of the coal I put up for the heat. Yees may as well go home and save your moulds for to-morrow's heat; for yees will not run your work to-day."

From that time until the blast went on, we were looked at shyly by all the moulders except two, who had seen us melt in other foundries; but the foreman and these two assured them that we understood our business and they would have a good heat, which probably saved us from being driven out; for there was a tough lot of stove-moulders in Troy in those days, who considered their rights sacred and that no punishment was too great for any man who encroached upon them.

When the blast was put on, the moulders gathered round the cupola and watched every tap until the iron came down so hot and fast that the first turn could not handle it, and the second turn was called up, and they were all kept on the run until the end of the heat. Getting iron so fast and hot was something

the moulders had never been used to in that foundry, and a number of them wished to know if we were trying to kill them all by giving them the iron so fast. But all were delighted with getting hot iron to pour off their work and getting through so early; and as we went along the gangways to see how the castings were turning out, a number of them asked us to wait until they were shaken out and have a glass of ale with them, which was the great drink of the Troy moulders. Had we waited for them we probably would not have reached our hotel that evening, for almost all of them dropped into a nearby saloon after they were through with their day's work, and we should have been asked to drink with every one of them.

In this heat we had used considerably more coal than we considered necessary, as we were not familiar with the working of the cupola and desired to be on the safe side and make hot iron, even though the melting was a little slow, which was the case. Two hours were required for the heat, but even this length of time was fully two hours better than they had been doing, and all the machinery required for mounting was run during the heat without stopping the engine for half an hour to get up steam before putting on the blast.

On the following day we reduced the coal a little more, and on the third day reduced it until we were melting six and a half pounds of iron to one of coal, and the heat was melted in one hour and thirty minutes. This was as fast as the moulders could handle the iron; and as we did not consider it safe to melt iron for stove plate with less fuel, although we could have done so, and they did not desire it melted any faster, we made no further attempt to save fuel or reduce time of melting.

The foreman learned very rapidly, and at the end of three days was fully competent to oversee the work, and they had no further trouble in melting or with hard iron, and were able to melt up all the scrap from their recent fire with the brands of pig iron they had on hand, and it was not found necessary to put in a larger engine and boiler to get a sufficient blast, after they had learned how to manage the cupola.

The cause of bad melting in this foundry was plainly indicated to an experienced melter at first glance by the lining in front of and around the charging door, namely, too great a quantity of fuel in the cupola and too small a volume of blast for that fuel. So large a quantity of fuel was charged for a bed that the iron placed upon it did not come within the melting zone, and could not be melted until the surplus fuel burned away and permitted it to settle into the zone. Each charge of fuel to replenish the bed was too heavy, and the greater part of it had to be consumed before the iron placed upon it was permitted to enter the melting zone, and the slow melting was due to the time required in consuming the surplus fuel before the melting could take place. The hard iron in parts of the heat was due to uneven charging, which permitted the scrap at times to be melted by itself and drawn from the cupola without being mixed with melted pig, and the entire mass of iron was hardened by being subjected for a long time to a high degree of heat before it was permitted to enter the melting zone and be melted.

To increase the volume of blast the speed of the blower had been increased to fully double the number of revolutions per minute given in the directions for running it; but the volume of blast had been decreased in place of being increased, as was supposed it had been by the increase of speed, and the cupola received less blast.

We had no means of definitely determining to what extent it was decreased, but from the appearance of the blast in the cupola at different stages of the heat, before and after decreasing the speed of the blower, we concluded that the volume of blast was increased fully one-half, by running the engine at its normal speed and reducing the speed of the blower to the number of revolutions given in the directions for running it.

This is one of the cases where the cupola air-gauge in common use would have been of value, for it would have indicated a high pressure of blast before the speed of the engine was increased, and located the trouble at the cupola in place of at the engine.

WARMING UP A CUPOLA.

In 1881 we visited the plant of the Providence Locomotive Works, Providence, R. I. The superintendent, Mr. Durgon, we believe was his name, wished to know if we were the Kirk that wrote "The Founding of Metals." We informed him that we were, and he replied that we might know all about a cupola, but our directions there given for constructing a cupola were no good, for he had constructed a cupola on that plan and it was a complete failure. It would not make hot iron, or melt half the amount per hour stated, or melt the heat before bridging over and bugging up. We informed him that if he had constructed the cupola exactly on the plan given it would do the work stated it would do. He invited us to go into the foundry and look the cupola over, and if it was not right he would make it right. We accepted the invitation and looked the cupola, blower and pipes all over, and could find no fault with them. The cupola was in blast at the time and we watched it melt for an hour; it certainly was a complete failure. The iron from the beginning to the end of the heat was dull, the melting slow, and the castings dirty and much harder than they should have been with the quality of iron melted.

We knew that the trouble lay in the management of the cupola, and decided to go round the next day and see the melter make it up for a heat. This the superintendent decided to let us do, although he thought he had the best melter in New England and the trouble could not be in the management of the cupola. On the following day we were on hand early and found the cupola badly bridged and bugged up. The melter soon had it chipped out and daubed up in good shape, and we saw that the trouble was not in the shape of the lining. He then put in a very nice sand bottom from which there could be no trouble in melting. He next put in shavings and a large quantity of wood, which he burned to dry the daubing. After this had been dried he added more wood and a good bed of hard coal, which he burned up to warm the

cupola for melting; and he certainly did give it a good warming, for when the doors were opened for charging the lining was heated to a white heat from the bottom to the stack. He then added a little more coal to level up the bed, and began charging.

As soon as we saw the extent to which the lining had been heated and the bed burned, we knew that the cause of the poor melting lay in the bed. In warming the cupola up for melting the life had all been burned out of the coal, and but little of it left to melt with. The cupola was filled with ashes below the tuyeres, and even if iron was melted hot it would be chilled in its descent through these ashes to the bottom of the cupola. The fuel thrown in just before charging was flaked off, broken and burned up by the intense heat almost before the iron could be charged, and had it not been that an extra high bed was put in before warming up not a pound of iron would have been melted.

We had frequently seen beds burned too much, but had never seen one burned to the extent of this one, or a cupola heated so hot before charging, and we stayed on the scaffold during the filling of the cupola with stock to see if the intense heat in the cupola had any effect upon the stock that would improve the melting in any way. The first charge seemed to be heated to a considerable extent by the hot lining and bed, and prepared for melting. After this charge was put in the cupola cooled off very rapidly, and before it was filled there was scarcely any perceptible heat at the charging door, and the stock could not have been heated to any extent above the first or second charge, by warming of the cupola. When the cupola had been filled the blast was put on, and the iron melted exactly as we had seen it do the day before, dull and slow. The cupola had been properly made up; plenty of fuel had been put in to make hot iron; charges of fuel and iron were of about the right proportion, and had been properly placed in charging, and there could be no doubt that the trouble in melting lay in the bed, as before stated.

The following day the superintendent put the melter on the other cupola and gave us full charge of the one constructed on our plan. We had it made up in about the same way as the melter did; put in our shavings, wood and all the bed, but a few shovelfuls to level up with before lighting up. After lighting up we waited until the heavy smoke was burned off and the fire began to show through the top of the bed. We then leveled up the bed and began charging. The only change we made in charging was to reduce the fuel in the bed about one-fourth, and that in the charges a little. When the blast was put on iron came down in about ten minutes, melted fast and hot throughout the heat, and the same amount of iron was melted in one-half the time it had been the previous day. This convinced the superintendent that the cupola was all right, for it did all we claimed it would do and a little more, and it convinced us that there was nothing to be gained in melting by warming up a cupola before charging.

BAD MELTING, CAUSED BY WOOD AND COAL.

In one of the leading novelty foundries in Philadelphia that we visited some years ago they were employing two cupolas, one 40 inches and the other 30 inches inside diameter, to melt 8 tons of iron, and it was very difficult to melt that amount in these cupolas. We knew that something was wrong, and went upon the scaffold to look into the cupolas and found the melter just putting in the wood for lighting up. He had put in quite a lot of finely-split wood, and had another barrow ready to add. After this was in, he went down and got three more barrows of cord-wood sawed in two and added this, and then some long wood, and when he had it all in, the cupola was filled to the bottom of the charging door. He then filled the cupola with coal to the top of the charging door, putting in the largest lumps he could find. We asked him why he put in so large a quantity of wood, and he said it was necessary to light the coal; and we presume it was, for some of the pieces of coal were as large as he could lift and place in the cupola, and it would re-

quire considerable heat to start a fire with such large coal; and he said they could not melt with any smaller coal. We tried to convince him that the cupola would melt better with less wood and smaller coal; but this was impossible, for he was an old melter and knew all about it.

Either one of these cupolas would have melted the amount of iron they were getting in the two, and in less time, had they been properly managed; but this was not done, and the firm afterwards put in two Colliau cupolas to do the work. The cause of poor melting in these cupolas was too great a quantity of hard wood, which took a long time to burn out, and in burning out the bed was burned to so great an extent that the cupola was filled with wood ashes and coal ashes before melting began. The large lumps of coal also contributed to the poor melting by making an open fire through which the blast escaped freely without producing a hot fire, such as would have been produced by smaller coal.

POOR MELTING IN A CINCINNATI CUPOLA.

In Fig. 24 is seen a sectional elevation showing the condition of a small cupola we saw in Cincinnati, Ohio, a few years ago. This cupola would not melt, the founder said, and could not be made to melt. He had put in a new fan, and now his melter wanted a blower, and said the cupola would not melt without a forced blast. We examined the cupola, and suggested to the founder that he needed a new melter worse than a new blower.

The cupola had not for a long time been properly chipped out, and a belt of cinder and slag varying in thickness from four to six inches had been permitted to adhere to the lining above the melting point, and another belt of cinder and slag projected from the lining. Between these two projecting belts the lining had burned away, making a deep hollow at the melting point. Entirely too much fuel had been consumed in melting, or the belt of cinder and slag could not have formed above the melting point.

We had all the projecting humps chipped off and the hollows

FIG. 24.

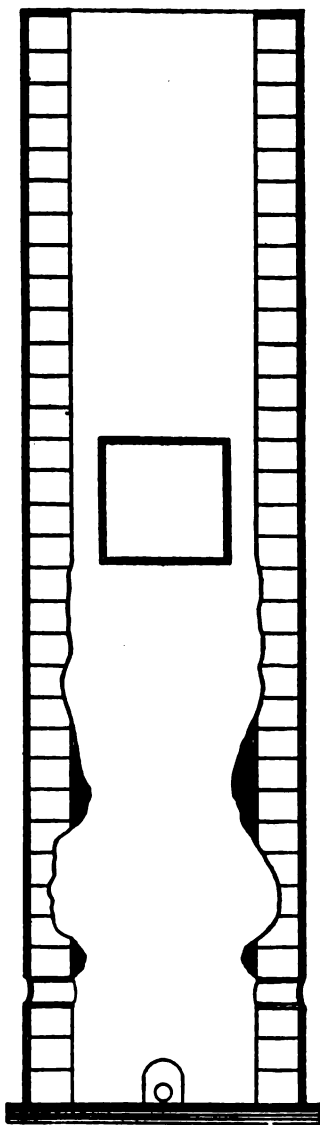

ILLUSTRATION OF BAD MELTING.

filled in with fire-brick and daubing, so as to give the lining an even taper. The cupola was then properly charged, and there was no trouble in melting iron hot and fast.

UNEVEN BURNING OF THE BED.

We were once compelled to dump a cupola at the foundry of Perry & Co., from the carelessness of the melter in placing the shavings and wood in the cupola in such a way that they did not light up the fuel evenly, and in putting on the blast when the bed was only burned up on one side. We had not noticed it, and he thought the blast would make it burn up on the other side. This it did not do, and after the cupola had been in blast a short time it had to be dumped.

The careless way in which shavings and wood are often thrown into a cupola from the charging door frequently causes an uneven burning of the bed and bad melting. We had a number of poor heats in our own foundry, due to this kind of carelessness, before discovering the cause of them.

We might relate many more examples of poor melting in various foundries, but these will probably suffice, as the causes of poor melting when a cupola is properly constructed will generally be found in the shape of the lining, burning of the bed, or quantity of fuel used in melting, examples of which have here been given.

CHAPTER VIII.

CUPOLA FUELS.

IN these days of advancement in foundry practice the subject of cupola fuel is frequently referred to in several scientific papers, and inquiries in regard to the use of various fuels are frequently made, with a view of reducing the cost of fuel and doing more economical melting.

Coke, when of good quality, is undoubtedly the best cupola fuel. With it, iron may be melted rapidly and of any degree of heat desired for the work to be cast. It therefore possesses or gives the two requisites of modern foundry practice: rapid melting and hot fluid iron. But all coals do not make good cupola coke, and foundries located at a great distance from the foundry coke centers frequently find that the cost of transportation makes their coke very expensive, and as the saying is, "costs its weight in gold."

These are the founders who are looking for a cheaper and better cupola fuel. The latter, we fear, will be hard to find, but the former may be had, and a few recollections of melting done when cupola fuels were not so perfect as to-day and of experiments made with various fuels may be of interest.

GAS AND LIQUID FUEL.

The question is frequently asked: Why cannot iron be melted in a cupola for foundry work with gas, such as natural gas, illuminating gas; or liquid fuel, such as petroleum, oil, benzene, gasoline, etc., more economically than with coal or coke?

The reason these fuels cannot be used in a cupola is that the latter is constructed upon the principle of melting iron in direct contact with the fuel consumed in melting it.

Iron, when first reduced from a solid to a molten state in a cupola, is not sufficiently fluid to flow into a mold, and must be superheated and made more fluid than when first melted before it can be used for foundry work. And a cupola fuel must be of a sufficient density to support the iron while melting, and to superheat it to a sufficient extent before dropping to the bottom of the cupola to run the work to be cast.

Gas and liquid fuel possess sufficient heat-producing units to melt iron in a cupola, but they are deficient in the requisite supporting properties of a cupola fuel. And iron, when melted by them, drops as soon as melted to the bottom of the cupola, where it cannot be superheated, or at least has not been superheated by any plan yet devised.

The writer, like many others, conceived the idea of melting iron in a cupola with these fuels many years ago, and in 1878 laid his plans for doing so before Mr. John S. Perry and Mr. Andrew Dickey, of the Perry Stove Co., two of the most advanced men in foundry practice at that time in this country.

They thought the plan feasible, and offered me every facility at their foundry plant, at Sing Sing, N. Y., for melting iron with any of these fuels I might select.

A small cupola was constructed with numerous small openings or tuyeres, through which a blow-pipe flame could be thrown upon the iron. At each of these openings a lamp filled with kerosene oil was placed, and the flame from the burner directed upon the iron by means of blow-pipes connected with a main blast-pipe supplied by a fan-blower.

By this means it was hoped to melt iron as rapidly in a 12- or 18-inch cupola as it could be melted in a 60-inch cupola with anthracite coal.

For the first test a bed of coal was put in up to the first row of tuyeres to support the iron and keep it off the sand bottom. When the coal was well burned iron was charged, and the numerous blow-pipe flames were directed upon it through the tuyeres. The iron was rapidly melted in this test by the blow-pipe flames, but was not sufficiently fluid when drawn from the tap hole to be cast.

To overcome this difficulty the melting zone, which had only been about one foot in depth, was increased to four feet, and an increased number of blow-pipe flames directed upon the iron. This caused the iron to be melted more rapidly, but did not increase its temperature or make it more fluid, but rather decreased its fluidity; for the rapid melting increased the body of molten iron passing through the bed of coal, causing it to pass through more rapidly, and it was not superheated by the bed to the same extent as when the melting was not so rapid.

After a number of failures in this line to produce a hot iron, it was decided to abandon the lamps and convert the oil into gas with a view of getting a hotter flame.

A retort was cast and after being properly connected with the cupola was charged with crude petroleum, and the flame from the gas generated directed upon the iron by means of the blow-pipes as before, throughout a four-foot melting zone.

This plan melted the iron rapidly, but like the other, failed to produce a hot fluid iron.

A bed of coal was then placed in the cupola and a light blast put on for the purpose of superheating the iron, after being melted with the gas. This plan produced a hot fluid iron, but after superheating a limited amount of iron the bed became exhausted and the only way to replenish it was to draw off all the iron, shut off the gas and put in a new bed.

The fresh bed had to be heated and the temperature of the melting zone brought up to the melting point before melting could be resumed. This resulted in considerable loss of time and waste of fuel in melting and was not considered practicable.

The blow-pipe theory was then abandoned and a series of pipes placed in the melting zone, for the purpose of superheating the gas before burning it and creating a more intense heat than we had yet obtained.

This plan melted the iron, but as before failed to produce a hot fluid iron, and the pipes in a short time became so choked with carbon that the gas failed to pass through them and melting stopped. This difficulty could have been overcome to a

sufficient extent to prevent the formation of carbon in them, but the iron melted was not satisfactory, and this plan was abandoned.

After these repeated failures Mr. Perry, Mr. Dickey, and their entire foundry staff were consulted as to how a hot iron could be obtained in melting with these fuels, and a number of plans suggested by them were tried, all of which proved failures. It was finally decided that a hot fluid iron could not be melted in a cupola with these fuels, no matter how hot the melting zone might be made, for the reason that the iron when melted dropped through the melting zone so rapidly that it could not be superheated.

Since these experiments I have been called upon several times to assist in devising a plan to melt iron in a cupola with these fuels, and have learned of other experiments having been made, all of which proved failures. So far as I know, iron has never been melted in a cupola sufficiently hot and fluid for general foundry work with any of the gases or liquid fuels.

Iron may be melted for foundry work with these fuels in furnaces especially designed for their use.

Brass and other metals may also be melted with them in a properly constructed furnace for using them.

One of the latest and most successful experimenters in designing and constructing furnaces for the melting of metals with oils and gases is W. J. Brown, Philadelphia, Pa., and founders favorably located for using such fuels may gain further information on the subject by addressing the J. W. Parson Co., Philadelphia, who are handling the furnace.

CHARCOAL FUEL.

The first fuel that was used in this country in smelting iron from its ores and also in cupola practice was charcoal, and for many years it was the only fuel available for these purposes. It produced a superior iron in many respects to that obtained with fuels in general use at the present time, but with the increase in population and disappearance of the forests, char-

coal is no longer available for this purpose; except in mountainous districts where land is worthless for any other purpose than the growing of timber, or in thinly populated districts where the forests have not yet been destroyed.

Such districts are generally located a long distance from the cupola fuel centers, and a few points on cupola practice with charcoal fuel may be of interest to foundrymen situated in those localities, and also to others who are unable to get a satisfactory iron with other fuel.

My experience in melting with this fuel in cupolas has been limited to small cupolas of from 20 to 30 inches inside diameter. But the fuel will carry as heavy a burden in a cupola as in a blast furnace, and is therefore available in melting in any sized cupola up to that of a charcoal blast furnace, which will include the largest cupolas now employed in the melting of iron for foundry work.

When melting with charcoal the fuel and iron are placed in the cupola in charges, in the same manner as when melting with coal or coke. A sufficient quantity of shavings, straw, or other combustible material to ignite the fuel is first placed in the cupola. Upon this a layer of small soft wood, and upon this a bed of charcoal extending to from 18 to 20 inches above top of tuyeres. Upon this a charge of iron, then a charge of charcoal, and upon this a charge of iron, and so on until the entire heat to be melted is placed in the cupola.

As charcoal is light and readily combustible, it is customary to fill the cupola with stock before lighting the fire, and to avoid wasting the fuel, to put on the blast as soon as the charcoal has become ignited, and there is a good fire in it at the tuyeres.

Charcoal does not carry as heavy a burden as coal or coke, and the charges of iron are made lighter and more numerous than when melting with these fuels.

The weight of charges of fuel and iron is varied to suit the volume of blast, which should be lighter than when melting with the harder and less freely combustible fuels.

The charges of fuel are made about 6 inches in depth or thickness, and the largest amount of iron which can be melted at a charge is the amount that can be melted without reducing the bed to such an extent that the next charge of fuel will not replenish the bed and bring it up to the top of the melting zone for melting the next charge.

When charges of fuel and iron are properly proportioned iron may be melted sufficiently hot to run the lightest of castings at a ratio of from 3 to 4 pounds of iron to a pound of fuel.

It has been found in furnace practice that the best charcoals for fuel are made from the hard woods, and from small timber rather than from the large; and the second and third growth small hard timber makes a charcoal that will carry a heavier burden and last longer than charcoal from first growth timber.

Small cedar timber makes a very good fuel charcoal, and is the principal wood used for this purpose in some sections of the south.

There are sections of this country where more economical melting can no doubt be done with charcoal than with coal or coke, but the results obtained when melting with charcoal are not to be compared to those obtained with either of the above fuels when fast melting and hot iron are desired.

ANTHRACITE COAL AS A CUPOLA FUEL.

The principal mines of this coal are located in four counties of eastern Pennsylvania, and the known area of the anthracite fields at the present time is 472 square miles, and the output of coal about 75,000,000 tons annually.

Outside of these four counties in Pennsylvania there are only three anthracite coal mines in the United States, one in Colorado, one in New Mexico, and the third in Rhode Island. The aggregate output of these three mines is only about 60,000 tons per year, and the coal is a poor sort of anthracite.

The Pennsylvania hard coal fields are divided locally into four regions, the Lehigh, the Schuylkill, the Lackawanna, and the Scranton. These various fields produce different grades

of coal. That of the Lackawanna and Scranton regions is soft compared with that of the Schuylkill, and that of the Schuylkill soft compared with that of the Lehigh region.

There is also considerable difference in coal from the various mines in the same region. That from the deeper veins is generally harder than that from veins nearer the surface.

As a cupola fuel, in the days of anthracite fuel, coal from the Lehigh region ranked first, Schuylkill second, and that from the other two regions third.

Coal from various mines in these regions also had higher reputations than that from others. Of all the mines Old Mine Lehigh had the highest reputation as a cupola fuel. This coal was of a bluish cast of color, very hard, and when placed in the sun in large pieces presented all the colors of the rainbow. Coals from other mines in this region have the same characteristic to a greater or less extent, but that from other regions is generally of a black cast of color, and the softer the coal the blacker it is in the fresh fracture.

Some years ago when the largest pieces of coal that could be placed in a cupola were considered necessary for a good bed, these indications of the quality of a coal were considered of importance, as they enabled the expert foundryman to judge at a glance the quality of the fuel. But at the present time little or no attention is paid to them.

There are no records to show when this coal was first used as a cupola fuel, but there are records to show that the first mine in the Pennsylvania districts was opened in 1820, and the output of coal in that year was 300 tons. It was probably about this time that the coal began to replace charcoal as a cupola and blast furnace fuel.

How many years were required to introduce it for this purpose is not known, but one thing is certain, that it became the universal cupola fuel in all the eastern sections of the country and as far west as it could be obtained.

In 1875 I found it in use in many of the foundries in St. Louis, Chicago, Milwaukee, and various parts of Canada and all the eastern section of the country.

In the early days of the manufacture of coke, coal from almost any of the anthracite coal fields of Pennsylvania was considered superior to coke, but with the improvements made in the manufacture of coke from time to time coal has been compelled to give place to coke, until at the present time the use of coal as a cupola fuel is restricted almost entirely to the coal fields and near-by foundry districts where it can be obtained at a less cost than coke, and to foundries a long distance from the coke centers, to which coal is delivered by vessels at a less cost per ton of iron melted than coke, and its use has become so restricted that we are compelled to write of it rather as a cupola fuel of the past than of the present.

To illustrate the manner of charging and melting with coal from the different coal fields of Pennsylvania, I have selected from my notes three heats of about the same size melted in different sections of the country in which these fuels were most commonly used.

The first of these was melted March 25, 1876, with Lackawanna coal at the foundry of Jackson & Woodin, Berwick, Pa., a small town located near the Lackawanna or Wyoming coal fields. The iron was melted for car wheels and general car castings, and was not required to be very hot to run the work.

Bed Coal	1900	Charge Iron	4350
Charge Coal	500	" "	4350
" "	600	" "	4350
" "	700	" "	4350
	<u>3700</u>		<u>17400</u>
Total Coal	3700	Total Iron	17400
Per cent. fuel 21.26+			

Heat melted September 26, 1876, with Schuylkill coal at the foundry of the American Stove and Hardware Company, Philadelphia, Pa. The iron was used in the casting of stove plate and hollow ware, and required to be very hot and fluid to run the work.

Bed Coal	1500	Charge Iron	4000
Charge Coal.....	350	“ “	4000
“ “	350	“ “	4000
“ “	350	“ “	4000
“ “	250	“ “	2000
Total Coal.....	2800	Total Iron.....	18000

Per cent. fuel 15.55+.

Heat melted January 15, 1877, with Old Mine Lehigh coal at the foundry of the Wolf Stove Works, Troy, N. Y. Very hot fluid iron for light plate was melted in this heat.

Bed Coal	1400	Charge Iron	4000
Charge Coal.....	300	“ “	4000
“ “	300	“ “	4000
“ “	250	“ “	3000
“ “	250	“ “	3100
Total Coal.....	2500	Total Iron.....	18100

Per cent. fuel 13.81.

It will be observed that the weight of fuel in the first heat is increased each charge and the charges of iron remain the same throughout the entire heat, while the weight of fuel in the charges with the harder coal remains the same as long as the weight of iron remains the same, and is decreased as the weight of iron decreases.

In melting with coal it has been found that with the softer coals the bed gives out in a long heat, resulting in dull iron towards the latter end of the heat.

To obviate this the charges of fuel are increased to keep up the bed and prevent iron settling too low in the melting zone before melting. This is the mode of charging commonly followed when melting with soft coal.

It will also be observed that the per cent. of coal consumed in melting varies to a considerable extent. This is due in these heats to the quality of coal. This variation always occurs with the different coals under the most favorable conditions, and is due to the difference in the heat-producing units of the coal.

The following reports from fourteen large foundries located in different parts of the country and using different grades of coal show the per cent. of coal consumed in melting for one year to have been 15.55, 14.51, 15.17, 17.22, 16.12, 15.08, 15.48, 14.70, 14.95, 18.10, 20.00, 18.72, 20.39, 19.78.

The foundries are principally stove-plate foundries and foundries casting light work for which very hot iron is required, and they show the average melting done in well regulated foundries of this class.

Founders and melters who are accustomed to speaking of pounds of iron melted to the pound of fuel may at first glance, as we have known them to do, take these figures to mean pounds of iron melted with a pound of fuel, which is not the case. They represent the pounds and fraction of a pound of fuel consumed in melting one hundred pounds of iron.

Prior to the dates above given every foundry appears to have been a mystery unto itself, and nothing was published in regard to cupola fuel, and it was only by promise of absolute secrecy as to the founder furnishing them that these figures were obtained.

Prior to this date, and even at the time, it was the practice in many foundries to use in melting the largest pieces of coal they could obtain or place in the cupola. Such coal was considered necessary to make a bed that would last through a heat of two or three hours.

I have seen the largest pieces of coal a man could lift and place in a cupola put in for a bed, and low cupolas of from eight to ten feet filled with wood almost to the charging door to ignite these large pieces of coal; smaller pieces were used for charging, but they were generally entirely too large for this purpose.

This large coal did not make a compact fire, and large crevices or openings were left between them, through which the molten iron quickly dropped to the bottom of the cupola without being superheated in its descent, and it was only by using an excessive amount of coal that hot iron could be made. The average melting done with this kind of fuel, when hot iron was

required, was from three to four pounds of iron to the pound of fuel with the best of coal.

Later on it was the practice in many foundries to put in a bed of large coal and charge with small coal; this gave a better per cent. and the average melting was from four or five to one.

The writer was probably the first to call foundrymen's attention to this mistake in using coal, and while it is claimed by many that a cupola cannot be run by a book, my early work on cupola practice certainly revolutionized the use of coal in many sections of the country.

At the time it was published many old founders and melters ridiculed the idea of melting with small coal, and were so positive it could not be done that numerous bets of from one hundred to five hundred dollars were offered that it could not be done, and a long heat melted or hot iron made.

But these primitive ideas of using coal soon gave way to better judgment when once their attention had been called to the matter, and the use of small coal became universal.

Iron may be melted in a cupola with any size coal from the smallest to the largest if the quality of coal is good. The best results are obtained in either small or large heats with broken coal about the size of the fist or of the two fists, and no larger coal should be used either for large or small cupolas.

After the adoption of broken coal for melting, the per cent. of coal required for making hot iron was very much reduced, and the average melting in well managed cupolas in large and small heats was from five to seven to one, and in some cases as high as seven and a half was obtained. This was probably the best ever done, although there were founders and melters who claimed as high as ten to one, but I have never seen any such melting done either in regular or test heats, and men doing such melting probably did it in their minds, as many do at the present time who melt with a very small per cent. of coke.

When coke was first introduced into the coal melting districts of the eastern section of the country, many founders were afraid

to use it in their cupolas, and it was introduced by mixing it with coal, or by putting in a bed of coal and charging with coke and coal, and this practice is still kept up in many foundries where the two fuels can be obtained at the same price per ton of iron melted; it being claimed that a coal bed lasts longer than a coke bed, and also a mixture of the two fuels in the bed and charges makes a hotter iron and gives life and fluidity to the molten iron.

There is nothing in any of these claims, for a bed of one fuel will last as long as the other, and as hot, fluid and lively iron can be melted with one fuel as with the other, or with a mixture of the two fuels.

Another claim made for the mixture of the two fuels is that more rapid melting can be done and larger heats melted with mixed fuels than with coal alone.

There is some truth in this claim, and founders melting with coal can do more rapid melting and may increase the melting capacity of their cupolas by mixing the two fuels in the bed and charges or in the charges alone, or by putting in a bed of coal and charging with coke.

The following heats melted with mixed fuels will illustrate the manner of charging and melting with the two fuels:

Heat melted in a 48-inch Colliau cupola with No. 6 Baker blower, tuyeres 18 inches above the bottom, Schuylkill coal and Connellsville coke used in melting. Iron melted for general machine castings.

Bed	Coke	Bed	Coal	Bed	Iron
"	1200	"	600	"	4000
Charge	250	Charge	100	Charge	4000
"	250	"	100	"	4000
"	250	"	100	"	4000
"	250	"	100	"	4000
"	250	"	100	"	4000
"	250	"	100	"	4000
"	250	"	100	"	4000
"	250	"	100	"	4000
Total,	3200	Total,	1400	Total,	36000

Per cent. coke 3.88+.

Per cent. coal 8.88+.

Per cent. fuel 12.77.

Heat melted in 54-inch Whiting cupola with No. 6 Baker blower, tuyeres 18 inches above bottom, Schuylkill coal and Connellsville coke used in melting. Iron melted for light mal-leables and required to be very hot.

Bed	Coal	Bed	Coke	Bed	Iron
"	2800	"	60	"	3200
Charge	150	Charge	60	Charge	1900
"	150	"	50	"	1900
"	150	"	50	"	1900
"	150	"	50	"	1900
"	150	"	50	"	1900
"	150	"	50	"	1900
"	150	"	50	"	1900
"	150	"	50	"	1900
"	150	"	50	"	1900
"	150	"	50	"	1900
"	150	"	50	"	1900
"	150	"	50	"	1900
"	150	"	50	"	1900
"	150	"	50	"	1900
Total.	4900	Total,	770	Total,	29800
Per cent. fuel 19.02.		Per cent. coke 2.58.		Per cent. coal 16.44.	

In the first heat, the per cent. of coke predominates and was employed to do fast melting. The coal was used to give more body to the fuel and make hotter iron. In this case, the coke in the bed and charges was put in first and the coal on top of it. In the second heat, the per cent. of coal predominates, it being the cheaper fuel in this instance, and the small per cent. of coke was employed to make the cupola work more open and free.

In this case, the coke was put in on top of the coal, as is generally done when coke is used for this purpose.

The two fuels are also used in various other ways. In some foundries a bed is put in entirely of coal and charging done with coke alone, in others the bed is made of equal parts of coal and coke and the charges of the same proportions. In such cases it is the practice to put in the coke first and the coal on top.

Coal, unlike coke, is useless as a fuel after it has been sub-

jected to the intense heat of a cupola and cooled again, although the coal when broken appears to be as good in the center as before heating. I do not know of any analysis having been made to determine the cause of this; but it has been demonstrated that it cannot be burned alone in a core oven furnace or in a heating stove, and when mixed with fresh coal tends to deaden the fire and decrease the heat rather than increase it; and when placed in the cupola with fresh coal probably produces no heat. It does not pay to recover such coal from the cupola dump for heating purposes.

CUPOLA COKE.

From a paper entitled "A History of Connellsville Coke," prepared by Mr. F. C. Kieghley, and read before the Central Mining Institute of Western Pennsylvania, it appears that coke was first made in this country in 1817 at Plumsack, Fayette County, Pa., for rolling-mill use.

In 1837 F. H. Oliphant made coke at his Fairchance Furnace, near Uniontown, Pa. All the early coke was made on the ground, in what was known as coke rickets.

The first coke made in ovens was in about 1841. In that year, Province McCormick and James Campbell, two carpenters, and John Taylor, a stone mason, commenced making coke with two ovens, and in the spring of 1842 had enough coke stacked to fill two boats, or about 800 bushels, which they took down the river on a high stage of water to Cincinnati, Ohio.

This appears to have been the first shipment of coke as an article of commerce of which there is any record. A part of this cargo was afterwards boated by canal to Dayton, Ohio, and was there sold to Judge Gebhard, a former resident of Pennsylvania, who then had a foundry in operation at Dayton. He used the coke in his establishment and found it so well adapted for his purpose that he afterwards came to Connellsville and proposed to Campbell and McCormick to make more.

This appears to be the first record of Connellsville coke hav-

ing been used in a foundry, for in a long research I have been unable to find any record of it having been used prior to this date; but it is likely that coke was used in foundries prior to this date. For in the early days it was the custom of foundrymen to make their own coke, and this practice was still in vogue in the sixties; and as late as 1863 the coke ovens of the A. Bradley Stove Works of Pittsburg, Pa., were still standing in the foundry yards, although they were not in use at that time. At a still later date we have seen foundrymen making their own coke at a distance from Pittsburg, and it was not until late in the sixties that it became the general practice of foundrymen to buy their coke, even in the vicinity of Pittsburg.

It was the practice for two or more foundries in these days to build a coke oven together, and either make their coke together or take turns using the ovens. I remember when a boy going to school, one of these ovens built at Sharon, Pa., by William McGilvery & Co., and Joseph King & Co. It was located in Pine Hollow, near the Jennie Berg Hill, alongside of a tram road, constructed to carry coal from the mines for shipment by the canal, and was only in operation occasionally, when a supply of coke was required by either foundry.

When in operation in the winter the boys always went to this hill to coast and get warmed at the coke oven, and many times have I warmed my shins at the old coke oven, when a boy. Later on, when a moulder in the employ of Joseph King & Co., I learned the history of the oven, which was removed in 1867, after having been abandoned for a number of years, when the supply of coke was received from Pittsburg and known as Pittsburg coke, made from Pittsburg coal. At that time there were numerous coke ovens along the Monongahela River and Allegheny Valley Railroad, employed in manufacturing foundry coke, which was known as Pittsburg coke. Later on, Connellsville coke came upon the market, and about 1870 or '71 completely replaced the Pittsburg coke as a foundry fuel.

In these various cokes may be traced the advancement made

in the manufacture of coke. That made at Sharon was a soft, dark coke, weighing about 32 pounds to the bushel. Pittsburg coke was a denser coke of a dark color, weighing 46 pounds to the bushel. Connellsville coke was of a light color, and when put upon the market in its early days, weighed 46 pounds to the bushel. The manufacture of this coke has been improved until we now have it of a silvery white, weighing as high as 72 pounds to the bushel.

Another coke that had a high reputation in early days was Blossburg coke, made at Blossburg, Pa. The supply of this coke was limited and it never came into general use, and I do not remember ever having used it in melting. Numerous other foundry cokes have been put upon the market at various times, but they have, so far as I have been able to learn, proven failures to a greater or lesser extent. Among these were Hocking Valley coke and others made from Ohio coal.

The cause of failure was due to the large per cent. of sulphur in the coal, which was not removed in the process of coking and could not be removed by various plans tried for washing the coal and preparing it before coking, or by devices in the construction of ovens for its removal.

When engaged in the foundry business in Ohio in 1871 a coke oven was constructed at Urichsville, Ohio, and I was given a half car load of this coke to try it. The coke had the appearance of being a good foundry coke, but when tried in the cupola hardened the iron to such an extent that the casting was worthless, and after a number of attempts to use it by changing the mixture of iron it was condemned. Other founders who were induced to try it had about the same experience with it, and when passing the oven a few years later I found it abandoned and a complete wreck.

No coal has yet been found in this country equal to the coal of the Connellsville coal region for the manufacture of coke. This region has become the great manufacturing coke center of this country and the output has increased from that of a few ovens to thousands, amounting to millions of tons of coke

annually, and probably ninety per cent. of all the foundry coke used in this country, at the present time is Connellsville. It carries a heavier burden in a cupola and melts iron more rapidly than any other coke. It is said to be freer from impurities detrimental to iron than other cokes, and is the most economical fuel for the cupola, although the cost of transportation may render it expensive.

When this is the case the question of economy when melting must be considered by the founder, and I shall endeavor to give a few points on this subject.

That a coke should be a good cupola coke, it is not necessary that it should in every respect be equal to Connellsville. A coke that is worthless in a blast furnace producing 700 tons of iron a day and kept in blast for many months, or as long as the furnace lining will last, may be a good coke in the cupola melting a few tons of iron and only in blast for from one to two or three hours.

A soft coke, free from impurities detrimental to iron, may be more economical than a hard one, even if double the quantity is required to do the melting and more time is consumed in melting.

Gas-house coke may be used for melting small heats and coke made in the vicinity for other purposes may be used for melting if the cupola is managed to suit the coke, or founders may find it more economical to construct ovens and make their own coke from coal in the immediate vicinity, as did foundrymen years ago, than to pay for transporting the better grades long distances. Almost any coke will produce hot iron in a cupola if properly managed.

Two things are necessary in the manufacture of a good foundry coke. First, a good coking coal free from sulphur and other impurities detrimental to iron. Second, a properly constructed oven and a knowledge of the process of coking.

Foundries located at a long distance from the coke centers, that contemplate making their own coke with a view of reducing cost in melting, should bear these facts in mind, and have

the available coal analyzed or thoroughly tested by coking in a small way, before going to the expense of constructing an oven or ovens of sufficient capacity to supply their wants.

In the early days of melting with coke it was the custom in filling a cupola, after putting in the bed, to mix the iron and fuel by putting in a shovel or two of coke and a few pieces of pig or a few shovels of scrap, and so on, until the entire amount of iron to be melted was placed in the cupola.

Cupolas were filled in this way upon the theory or supposition that iron was melted in a cupola all the way up to the charging door, and two or three sets of tuyeres were placed in cupolas, one above the other, that the tuyere pipes might be raised to a higher set of tuyeres and the lower ones closed, when it was desired to collect molten iron for a large casting.

This practice was still in vogue in some sections in the early seventies, but had been abandoned long before that time in other sections; and the practice of placing fuel and iron in charges as at the present time adopted, upon the theory that iron is only melted in a cupola in a given space, which has been designated the melting zone.

With the system of mixing the iron and fuel the per cent. of fuel consumed was much larger than with the present system, and the melting slower. When visiting foundries where this system was in use, I have frequently reduced the fuel consumed one-half and the time required for melting an equal amount, by changing the manner of filling the cupola to the charge system.

In early days, coke was all measured, bought and sold by the bushel, instead of by weight, and after the adoption of the charge system bushel baskets were used for measuring the coke and placing it in the cupola. And a founder when speaking of the ratio of fuel to iron melted, would state the amount melted per bushel of coke, in place of to the pounds of coke.

The bed and charges of coke were placed in the cupola by measure in place of by weight. To learn the number of bushels of coke required for a bed for a cupola of any given

diameter, the number of cubic inches in the space to be filled was ascertained, and the number divided by the number of cubic inches in a bushel.

For example, we will take a 30-inch cupola, with tuyeres 6 inches in diameter located 12 inches above the sand bottom. This would make 18 inches from bottom to top of tuyeres. Add to this 18 inches for bed above top of tuyeres and we have a space or depth to be filled of 36 inches. The area of 30 inches diameter is 707; multiply this by 36 and we find the area to be filled to be 25,452 cubic inches. Divide this number of cubic inches by the number of cubic inches in the average bushel, 2,200, and we find $11\frac{1}{2}$ bushels of coke would be required for a bed for this cupola.

The charges of coke were generally made 5 inches in thickness, and the amount of coke required learned by multiplying 707 by 5 and dividing the product by 2,200, which gives the amount of coke required for each charge, 1.6 bushels.

To these bushels were added, from time to time, a sufficient amount to make up for the burning away of the lining and enlarged diameter of the cupola.

The melting qualities of a coke were judged by its weight per bushel. A soft, porous coke weighed 32 pounds and the harder and better the coke the heavier it weighed up to 46 pounds per bushel, which was regarded as the maximum weight of the best coke. The weight of a charge of iron on the bed varied with the quality of coke, and was from an equal weight of the bed to three times its weight. And the amount of iron placed in each charge varied from two to ten times the weight of the coke placed in the charge to melt it.

The number of pounds of iron melted to pounds of fuel varied with quality of coke and size of heat, and was from 3 to 8 to 1. This was the common practice of judging the quality of coke and melting in all the leading foundries in the early sixties. And in many of them there was more system in melting than in one-half the foundries at the present time.

In the early days of coke its quality varied to a considerable

extent. This was due to the differences in the coal from which the coke was made, and again to badly designed and poorly constructed ovens and to lack of knowledge of the process of coking.

These difficulties have been overcome by the discovery of veins of coal more suitable for coking, the construction of ovens better adapted for the purpose, and a more perfect knowledge of the process of coking. Coke at the present time is of a more uniform grade than years ago, but there is still a considerable difference in the characteristics of the various kinds.

This variation is due in some instances to the quality of coal, but more frequently, especially in coke of the Connellsville region, to the time consumed in coking. This region has produced from time to time 24, 36, 48 and 72-hour coke. These cokes differ in density or hardness, according to the time consumed in coking, and vary in weight from 40 pounds to 72 pounds per bushel, which latter is said to be the weight of the Davis by-product coke.

The greater the length of time coke remains (up to a certain period) in an oven in the process of coking, the denser and harder it becomes. And the harder a coke, the longer time required to consume it in a cupola, the heavier the burden it will carry and the larger the amount of iron it will melt.

It therefore follows that a 72-hour coke is the best cupola coke; next to this is the 48-hour coke, and so on down to the 24-hour coke.

Seventy-two-hour coke for many years, and if we are not mistaken, at the present time, is only made once a week in the Connellsville region. The coke men of this region follow the example of the Lord, as set forth in the Bible, "And on the Seventh Day rest from all their labors," and no ovens are drawn on Sunday. The coke in ovens falling due to be drawn on Sunday as 48-hour coke, is permitted to remain in the ovens until Monday, when it becomes 72-hour coke, and this is the only 72-hour coke made. It is generally kept for filling

foundry orders, but the supply is limited, and when exhausted orders are sometimes filled with 48-hour coke instead of 72-hour.

This is one of the reasons for the variation in the quality of foundry cokes and the cause of bad working of cupolas and poor melting, for the different grades of coke require a variation in the charging of a cupola, when coke is charged by weight in place of by measure.

The cupola furnace is a space furnace in which iron is melted in direct contact with the fuel, and is supported by the fuel previous to melting.

To melt iron in this furnace, a sufficient space must be filled with fuel to admit of the iron to be melted entering the melting zone when the cupola is in blast as rapidly as it can be melted.

If the amount of fuel is insufficient to fill the cupola to a proper height, the iron placed upon it settles below the melting zone and cannot be melted; and if the fuel is in excess and fills the cupola above a proper height, iron placed upon it cannot be melted until the excess of fuel is burned away, and permits the iron to settle into the melting zone.

It is therefore a matter of space occupied or filled by fuel rather than of weight of fuel. With the old rule of placing coke in a cupola by the bushel, all cokes filled the same space, no matter to what extent their weights might differ per bushel. But the same weights of the different cokes do not fill the same space.

To illustrate this we will take the cupola above referred to, for which 11.56 bushels of coke is required for a bed. This number of bushels of coke of the various weights per bushel gives the following total weights:

Coke 32 lbs. per bushel.....	369.92
Coke 46 lbs. per bushel.....	531.76
Coke 60 lbs. per bushel.....	693.60
Coke 70 lbs. per bushel.....	809.20

B'T:

The total weights of any of these cokes would make a bed

for this cupola, but the same weight of no two of them would make a proper bed.

For instance, were we to put in the weight of 11.56 bushels of 32-pound coke, 369.92 of 70-pound coke, this amount would not fill the cupola to the top of tuyeres, and not a pound of iron could be melted with such a bed.

On the other hand, were we to put in the weight of 11.56 bushels of 70-pound coke, 809.20 of 32-pound coke, the cupola would be filled to such a height above the tuyeres that not a pound of iron could be melted until 439.28 lbs. of coke was burned away and permitted the iron to settle into the melting zone.

The same rule applies to the charges equally as well as to the bed, and when the space between the charges of iron occupied by fuel is too small, the bed is not properly replenished, and the result is dull iron after one or more charges have been melted.

When the space filled with fuel is in excess, irregular and slow melting results, due to the melting being stopped while the excess of fuel is being burned away to admit of the next charge of iron settling into the melting zone.

Melters who do not understand the space theory of a cupola will invariably increase the weight of coke in bed and charges when they have a soft, light coke to melt with, and decrease it when they have a hard, heavy coke. This is a mistake, and exactly the reverse should be done. For the lighter a coke, the more space it occupies, and the heavier a coke, the less space it occupies, as illustrated in the bed of 32-pound and 70-pound coke. And by increasing the weight of coke, or even putting in the same weight with a light coke as a heavy one too great a space is filled with fuel, and iron is placed too high in a cupola for either fast or economical melting.

This theory of melting should be followed by every founder melting with coke, and as the quality of the different cars of coke frequently varies to a considerable extent, some means should be devised or provided in every foundry for determin-

ing the weight of coke per cubic foot or bushel when such information is not furnished with the coke, and charging should be made to suit the quality of the coke.

Hot iron may be melted in a cupola with any grade of coke if this theory of melting is practiced; and equally hot fluid iron can be melted with a 32-pound as with a 70-pound coke.

But it must be remembered that a light coke is inferior to a heavy one as a cupola fuel. It will not carry as heavy a burden or melt iron as rapidly, and a cupola cannot be kept in blast in good condition for melting for so great a length of time. And with a very light coke, it is sometimes necessary to make the size of a heat to suit the coke, for even by tapping slag a cupola could not be kept in blast for any great length of time with light gas-works coke, while a cupola may be kept in blast as long as the lining will last with a good quality of coke, and good melting done throughout the heat.

The remedy in melting when coke is poor is not to increase the coke, but to decrease the weight of iron on bed and charges, and they should be varied to suit the coke. When a coke is light, and the weight placed in the bed and charges is reduced, the weight of iron placed upon them should be correspondingly reduced; and when coke is heavy, the weight in bed and charges should be increased and the weight of iron also increased.

Coke and iron should be evenly charged throughout a heat, that is, the proportion of fuel to iron should be the same.

The old rule of charging is to place three pounds of iron to one of coke in the bed, upon the bed, and ten to one upon the charges.

This rule is a good one, as it gives the proportion of fuel to iron throughout a heat, and with 46-pound coke and tuyeres of a certain height gives about the proper proportion of fuel to iron for fast and economical melting. But the rule is not applicable in all cases. In the first place, the rule does not apply to cupolas with tuyeres of different heights, for fuel under the tuyeres takes no part in melting, and when tuyeres are very

high the amount of coke required for a bed is so large that three to one cannot be melted upon it without lowering the top of the bed to such an extent that it is not restored to a proper height for melting by the next charge of fuel. The result is uneven melting and dull iron throughout the remainder of the heat.

With low tuyeres the weight of coke required for a bed is not so great, and four or five to one may be melted upon it with the same grade of coke without detriment to further melting.

Again, the rule does not apply accurately to coke of different grades; for we have found in a number of cases, when melting with gas works coke, that from one to two to one was the best that could be done on the bed, and from five to six to one the best that could be done on the charges; and in the same cupola we have melted four to one on the bed and ten to one on the charges with a good coke.

In regulating melting in different foundries we have found our best guide for bed and charges to be measurement and weight, as follows:

When melting in a cupola we had never seen melt, and for which previous melting was no guide for melting, we first obtained the measurement from sand bottom to top of tuyeres, then measurement from bottom of charging door down to a proper height for top of bed, and procured a pole or rod for determining this measurement when the bed was in. We then determined the quality of coke by weighing a bushel, or by inspection. The blast machinery and pipes were then inspected and a bed put in to suit the coke and blast. With a light coke the bed was made a little higher than with a heavy one. And with a strong blast it was made higher than with a light blast, the height of bed generally being from 18 to 20 inches above top of tuyeres.

When the tuyeres were very high, 18 to 20 inches above sand bottom, and the coke light, one to two pounds of iron were placed upon the bed to every pound of coke in the bed.

And with a heavy coke two to three to one were placed on the bed.

With low tuyeres, four to eight inches above sand bottom, and light coke, two to three to one; heavy coke, three to four to one. The top of bed and also charges of fuel and iron were made as level as possible before putting in the next charge. For charges of coke, a sufficient quantity was put in to properly cover the iron (about five or six inches), and separate charges of iron.

On the charges of coke were placed from three to five of iron to one with a light coke, and eight to ten to one with a heavy coke.

This means of determining the proper amount of fuel for bed and charges and ratio of iron on fuel, in bed and charges, seldom failed to produce satisfactory melting, which might or might not be improved.

To determine this the melting was watched from the time the blast was put on until the bottom was dropped for indications of necessary changes. All coke and iron was accurately weighed, the front put in and tuyeres closed as soon as bed was properly burned for charging, and charging began from two to three hours before blast was put on.

If iron failed to appear at the tap hole in five minutes after the blast was on, the bed was too high, and for the next heat was reduced a little. If iron came dull at the latter end of charges, charges of iron were too heavy and were reduced next heat.

If the cupola did not melt rapidly the charges of fuel were too heavy. If iron was not of an even temperature throughout a heat charges of fuel and iron were not of a proper proportion.

All these things were noticed and changes made in the charging until the cupola melted the largest stream of iron it was capable of melting suitable for the work to be cast, and an even temperature throughout a heat.

When this had been accomplished, the most economical melting that could be done in that cupola with the grade of

coke used was being done, and it did not matter whether two to one or ten to one was being melted, the per cent. of fuel to iron could not be reduced.

The question of per cent. of coke to iron or of the number of pounds of iron that can be melted to the pound of Connellsville coke is a matter upon which there appears to be a wide difference of opinion, and upon which few are capable or willing to give definite practical information.

Periodically there appears in the scientific and mechanical papers a good cupola record, in which the writer claims to have melted anywhere from 10 to 15 to one.

In Mr. West's work, "The Molder's Text Book," we find reports of melting with Connellsville coke from 24 foundries, in which the per cent. of fuel to iron of no two of them are the same and the ratio of fuel varies from $3\frac{8}{10}$ to $11\frac{4}{10}$ to one.

In these reports the size of heats varies to a considerable extent, but the largest heats do not always show the lowest per cent. of fuel to iron, and we find heats of 8,000, 10 to one; 41,000, 7.84 to one; 21,000, 5.91 to one; 3,500, 6.64 to one; and in very few of them do the largest heats show the best per cent. of iron to fuel, which would seem to indicate that the old theory, that the larger the heat the smaller the per cent. of fuel, was all wrong.

These reports indicate that the management of cupolas is very poorly understood by the majority of the foundrymen making them, or that others through a desire to excel have misrepresented their meltings; and we are inclined to believe the latter to be the case, for in all our experience in melting we have never seen any such melting done as reported by some of them; nor have we ever met a practical founder who made such extravagant claims.

Few practical founders claim to melt more than eight to one in their largest heats, and the majority of them do not state their average melting to be more than seven to one, and many place it even lower with the best of coke.

As stated above, the best and only guide the founder has to

economy in fuel is fast melting and iron of a temperature suitable for work to be cast; and when he melts his iron as fast as a cupola is capable of melting and of a temperature at the spout suitable for the work, he is doing all that can be done to save fuel, and no attention should be given to extravagant cupola reports made by other foundries.

BITUMINOUS COAL AS A CUPOLA FUEL.

Between the period of the discovery of bituminous coal in this country and the introduction of the process of coking, there should have been, and no doubt was, a period when this coal was employed as a cupola fuel by some of the many small foundries located in the vicinity of these mines.

But there appears to have been no record kept of this coal as a cupola fuel by any of the foundrymen of those days, or nothing published in regard to it ever having been used for this purpose. That there should be no such records is not strange, for nothing can be found upon the subject of any of the other cupola fuels, or mode of using them, prior to my work, "The Founding of Metals" (1877). Nor does there appear to have been anything published upon this subject in England or other countries prior to that date.

Twenty-five years ago I made inquiry among foundrymen and molders in different parts of the country as to the use of various cupola fuels in their early days. Many of them remembered melting with charcoal before the introduction of anthracite coal and coke in their locality, but only three, my notes show, remembered melting with bituminous coal.

Two of these were located in Western Pennsylvania and one in Ohio when melting was done with this coal without coking, but none of them had kept any record of the melting and were unable to give any practical data in regard to melting with it.

My own experience in melting with this fuel in a cupola has been limited to one cupola, that of Joseph King & Co., Sharon, Pa.

This firm received their supply of cupola coke at that time

from Pittsburg, Pa., by boat, on the Erie and Pittsburg Canal; and it was their custom to lay in a sufficient supply in the fall to last until the canal opened in the spring.

In the winter of 1865 and 1866 their supply ran short, and they were compelled to pay the high rate of a railroad that had just been opened the year before, look for other fuel, or shut down until the canal opened.

At that time the Sharon Iron Co. were using a very hard bituminous coal in their blast furnace without coking, and the foundry company were induced to try this coal in their cupolas.

The first heat with it was not a success. The iron melted hot and dull, fast and slow, and the greater part of it was so dull it had to be poured in the pig bed. But part of it, in different parts of the heat, was sufficiently hot and fluid to run light work. This indicated that the fuel would do the melting, but the cupola had not been properly charged.

For the next few heats the charges of fuel and iron were varied with better results, and in the third or fourth heats iron was melted sufficiently hot and fluid to run stove-plate and light jobbing work; and melting was done with this coal for a number of weeks, until the canal opened and they received a supply of coke.

This melting was done in a 28-inch cupola.

A bed was put in of the same height above the tuyeres, and the charges of coal made of the same weight as when melting with coke. But the charges of iron on the bed and those on the charges of fuel were made lighter, and the ratio of iron to fuel reduced from 7 to 1 with coke to 5 to 1 with coal.

This is as good a per cent. of fuel to iron as the majority of founders melting small heats in small cupolas obtain with the best of coke.

The quality of iron was not deteriorated by the coal, and it was not found necessary to make any change in the mixture to obtain as good a quality of iron in the castings as when melting with Pittsburg coke.

The coal used in this instance was very hard bituminous coal,

and was said to be the only coal mined in this section that could be used in a blast furnace without coking, which was probably the case, for when the mine became exhausted the furnace began using coke as a fuel.

All bituminous coals are not available as a cupola fuel. Some are too soft, fuse into a solid mass, or burn away too rapidly when subjected to a strong blast, and others contain so large an amount of sulphur that they harden the iron and render it brittle.

In selecting a coal, a hard coal free from sulphur should be chosen. When such a coal is not obtainable, small heats may be melted with a soft coal and a light blast, and sulphurous coals may be used for some lines of work by charging a better grade of iron than when melting with a fuel free from sulphur.

There are some sections of this country in which very hard bituminous coal is mined, that can no doubt be employed as a cupola fuel by small jobbing foundries located in districts where other fuels are very expensive.

CHAPTER IX.

FOUNDRY IRONS.

MANY old foundrymen, as well as molders, have never seen a blast furnace, and have only a limited idea of how pig iron is made, or what is meant by the terms hot blast, cold blast, charcoal, coke and anthracite iron.

The writer was employed in a foundry for a number of years as a molder before he learned the meaning of these terms, and the kind of castings the different irons were best suited for. He has frequently met foundry foremen who knew nothing about irons other than those used in the foundries at which they were employed. If called upon to use other irons, these men would know nothing of their characteristics, and many valuable castings would be lost, or prove unsuitable, before they became sufficiently familiar with the iron to know for what class of castings it was best suited, or how to mix and prepare the iron for the work to be cast.

This state of affairs is not to be wondered at when we come to consider that the characteristics of the various foundry irons have never been deemed of sufficient importance by writers on foundry matters to accurately describe them or indicate the class of work for which they are best suited.

The knowledge of iron other than that being used in many foundry districts is, to a great extent, only a tradition, which has been handed down from one generation to another, and even this knowledge, in many cases, has become extinct.

A short description of foundry irons will, no doubt, be of interest and of value to many founders, foremen and melters.

BLAST FURNACES.

The blast furnace is constructed upon the same general prin-

ciples as the cupola furnace. It is cylindrical in shape, is supplied with air for combustion by a forced blast through tuyeres placed near the bottom of the furnace. The latter is charged with fuel, ore, flux, etc., from the top, and not through a charging door in the side, as in the cupola. The iron is drawn from the furnace at the bottom and conveyed through a runner made of sand in the floor of the casting house to the pig-iron molds, also made in sand in the floor of the casting house, or into iron molds or chills.

The iron cast in sand molds is called sand pig, and that cast in iron molds sandless or chilled pig. Several new devices are now being tried for casting sandless pig that prevent chilling of the iron by the mold; this iron is known as sandless foundry pig.

The blast when forced into the furnace at the temperature of the atmosphere, or the same as that forced into a cupola, is known as a cold blast, and the iron produced from the furnace as cold-blast iron. When the blast is heated before entering the furnace it is called a hot blast, and the iron produced is called hot-blast iron.

A blast furnace may be open or closed at the top. The open furnaces permit the gases to escape, and are generally cold-blast furnaces.

The closed furnaces are closed by a hopper device resembling a bell, and are known as bell-top furnaces. The fuel, ore, flux, etc., for a charge are dumped upon the bell, which is suspended in the furnace at the top, and the charge is permitted to fall into the furnace by lowering the bell to a sufficient extent to admit of the stock sliding off the bell into the furnace. The bell is then raised into place and the furnace top closed.

The gases are permitted to escape from the furnace through large pipes connected with it near the top, and are used for heating the blast, which is heated to a high degree in a hot-blast stove before entering the furnace. The bell-top furnaces are all hot-blast furnaces.

Irons are also designated by the fuels used in smelting the

ores, thus: An iron smelted from its ores with charcoal and a cold blast is called cold-blast charcoal iron; that smelted with charcoal and a hot blast, hot-blast charcoal iron: iron smelted with coke, coke iron, and that smelted with anthracite, anthracite iron. All coke and anthracite furnaces are hot-blast furnaces, and the iron from them hot-blast iron.

CHARCOAL IRONS.

The charcoal irons, cold and hot blast, are comparatively free from the impurities found in coke and anthracite irons, imparted to them from the fuel with which they are smelted, and present the characteristics of greater strength than either of these latter irons. Charcoal irons are cast into long slender pigs, with a V-shaped groove in them on each side to facilitate breaking the pig into four pieces. The pigs are broken with difficulty, even when grooved in this manner, and a two-handed sledge, weighing from 20 to 30 pounds, handled by two men, is frequently required to break them. When broken, the fracture presents a rough, torn appearance, with a sharp-pointed crystal that jags the fingers when pressed upon them. They are graded Nos. 1, 2, 3 and 4. The No. 1 is a soft iron; No. 2 a grade harder; No. 3 a mottled iron, and No. 4 a white iron.

Cold-blast charcoal iron was the first iron ever made in this country, and was used in the manufacture of all kinds of castings, even for stove plate, which was not made so thin many years ago as at the present time. The No. 1 is high in combined carbon, and its tendency to chill when cast into light work is so great that it runs white on thin edges, and at any great distance from the gate, in light castings. The writer, when visiting an old foundry in Maryland at which stoves were made from this iron, many years ago, learned that only the softest No. 1 pig had been used in their manufacture, and that the gates and scrap from the work were not remelted, but were thrown into the dump, and only pig melted to insure soft castings. A dump was pointed out that was said to contain many tons of gates and scrap from this foundry.

The cold-blast iron was used in the manufacture of gear wheels, cranks, and all parts of machinery requiring great strength, and before the introduction of the steel hammer into rolling mills, and the age of steel, was the iron exclusively used in making large shafts for steamboats, mills, etc.

Many amusing stories are told by old foundrymen about casting these shafts. One recalled to mind is the casting of shafts on end and making them double the length required, that the pressure of iron in the upper end of the mold might make the iron in the lower end more dense or close, only the lower end being used for the finished shaft. This is said to have been a common practice in foundries having a high reputation for good shafts. The founders do not appear to have known that a close iron might have been obtained by using the lower grades of pig, or mixing the lower with the higher grades, and casting the shaft of its proper length. All the iron cannon used in the War of the Rebellion in this country, 1861-65, were made of this iron; hundreds of them were cast at the foundry of the Fort Pitt Works, Pittsburg, Pa., and the writer saw many of them when being finished at the lathe at these works. The iron cut like wrought iron, and many turnings from 20 to 30 feet long were hung up around the lathe room to show the quality of the iron.

This iron, owing to its high price and chilling tendency in light work, is at the present time only used by founders for special work, such as malleable iron, car wheels, cylinders, etc. In malleables it gives a stronger and smoother iron than any other, and, in fact, is the only iron from which first-class malleable iron can be produced. In car wheels it makes a strong wheel, and gives a chill of any desired depth when the different grades of the iron are properly mixed.

In cylinders it makes a strong, clean, close iron, free from grit, that polishes like steel, and does not wear rapidly or cut the piston head or packing ring.

For car wheels and cylinders, it may be mixed with coke or anthracite irons, and has been used to some extent in this way,

and good results obtained. But it must be remembered that the characteristics of a charcoal iron decrease in proportion to the amount of these irons that are added to it in a mixture, and the good qualities of a charcoal iron may be entirely lost if too large a percentage of other iron is used.

No rule can be given for mixing, as the percentage must necessarily vary with the quality of iron used and the resulting quality desired.

Attempts have been made to produce by chemical analysis an iron from coke or anthracite irons having the characteristics of a cold blast charcoal iron, and some success is said to have been met with in malleable iron and car-wheel works. But oleomargarine does not possess all the qualities of a good butter, and the imitation cold-blast charcoal iron will no doubt be found to be deficient in some of the characteristics of the genuine article.

HOT-BLAST CHARCOAL IRON.

Hot-blast charcoal iron presents all the characteristics of the cold blast except its chilling tendency, which is lessened to a considerable extent by the reduced amount or per cent. of combined carbon and increased per cent. of graphite carbon contained in the iron.

A deep chill cannot be obtained from the No. 1, but a chill of any desired depth may be obtained from a mixture of the lower grades. This mixture, however, does not give a chilling iron equal to the cold blast for car wheels.

The Nos. 1 and 2, when mixed in proper proportions, run very fluid and soft in light castings, such as stove plate, hollow-ware, bench work, pulley rims, etc., and they are the very best foundry irons for light castings requiring softness and strength.

This iron for many years was the only iron used for this kind of castings, and even after the introduction of coke and anthracite irons, at a very much reduced price compared with that of charcoal iron, was for years used by many foundrymen, and is still used exclusively by some of the old founders in localities

where it can be procured at a moderate advance over the other irons.

Some of the best known and most famous brands of this iron were those of the Hanging-Rock region, a mountainous district, on the Ohio River, in the vicinity of the town of Hanging Rock, Ohio. The mountains or hills in this vicinity furnished wood for charcoal for many small furnaces that for many years supplied the entire Ohio Valley from Pittsburg to the Mississippi River with foundry iron. Some of these furnaces are still in blast, but most of them have been abandoned, owing to the scarcity of wood, and the production of this iron has also been much reduced in other localities for the same reason.

One of the tricks of founders after the introduction of coke and anthracite irons was to keep a pile of the charcoal iron in the yard to show customers the quality of iron used in their castings. When a customer desired a very strong iron in his castings, he was taken into the yard and a pig of this iron broken after numerous blows with a heavy sledge. This test generally satisfied the customer, who believed he was getting an extra quality of iron, while the pig broken was likely the only one that went into many tons of his casting, the castings being made from the cheaper grades of iron.

COKE IRON.

This is probably the best known of all the foundry irons, for it is the iron used in a large majority of the foundries of this country making a general line of castings such as stove plate, hollowware, bench work, light and heavy machinery castings, etc.

The characteristics of the iron vary to some extent, owing to the quality of the ore from which it is smelted. That made from some of the Lake Superior ores is very strong. The No. 1 presents a sharp-pointed crystal in the fresh fracture, runs soft and strong in moderately heavy castings, but runs very hard in stove plate and other light castings. That made from some of the southern ores is very weak, the No. 1 pre-

senting a dull flat crystal in the fresh fracture, and running very soft in light as well as heavy castings. The best iron for light castings is that having these two characteristics in combination, and such an iron is made by furnacemen making a specialty of foundry irons from a mixture of different ores.

These characteristics of the iron should be remembered when ordering irons, and an iron selected suitable for the work to be cast.

Coke iron was first graded No. 1, No. 2 mottled and white iron. Later, it was graded Nos. 1, 2, 3, 4, 5, 6 and 7, with the addition of No. 1 A, No. 2 A, or No. 1 X, and No. 2 X. This fine grading was designed to accurately indicate the quality of iron and enable the foundrymen to order exactly the quality best suited for the work to be cast.

An effort is now being made by furnacemen in some localities to do away with grading by fracture, and grade from chemical analysis, which is said to more accurately indicate the characteristics of the iron and enable the foundryman to select an iron exactly suited for his work.

This grading is based to a large extent upon the per cent. of silicon contained in the iron. A high silicon, a soft iron. A low silicon, a hard iron. Silicon is placed in the iron in any desired per cent. by the grade of ores smelted, and irons are made to correspond with the numbers formerly used in grading. Thus, a 3 per cent. silicon iron presents similar characteristics to an iron formerly graded No. 1; a 2 per cent. silicon those of No. 2, and so on.

Coke irons are cast into short, thick pigs, as compared with those of charcoal irons. These heavy pigs, which are almost double the thickness of the charcoal pig, are broken more readily than the slender grooved pigs of that iron. Even the strongest of the best grades in no way compares with charcoal pig for strength.

The strength of the iron is indicated to some extent by the color, as well as shape, of the crystal. A dark bluish cast in the fresh fracture indicates a stronger iron than a light or silvery

cast. The No. 2 iron runs stronger in heavy and moderately heavy castings than the No. 1, but weaker in light castings, in which the iron is chilled to some extent by sudden cooling.

For light castings the best results may be obtained by mixing the No. 1 and No. 2 in the proportions of one-half of each, or two-thirds of No. 1 and one-third of No. 2. A mixture of about these proportions generally makes an iron that runs softer and more even in light castings than all No. 1.

The No. 3 grade is seldom used, except for very heavy castings; it is then generally mixed with the No. 2, and is employed in the mixture for the purpose of giving strength to the castings.

ANTHRACITE IRON.

The furnaces producing this iron are principally located in Eastern Pennsylvania, New Jersey, Maryland and New York, and were the source from which these sections of the country derived their supply of foundry irons for many years.

The furnaces were generally small ones and with anthracite coal, which smelted the ores very slowly, produced but a limited amount of iron. After the improvements in the manufacture of coke, it was found that these furnaces could be made to produce two or three times more iron with coke fuel than with anthracite fuel. This, together with the decrease in the price of coke, as improvements were made in its manufacture, induced the anthracite furnacemen to change their furnaces to coke furnaces. This change has taken place to so great an extent that very few anthracite furnaces are in existence at the present time. Even the anthracite furnaces in the Lehigh Valley, the very center of the anthracite coal fields, have changed to coke. The iron as a foundry iron was far superior to coke iron in the early stages of the manufacture of that iron; but with the advancement in the manufacture of coke, and consequent improvement in coke iron, the two irons presented very similar characteristics as foundry irons. The pigs of the irons are cast about the same size and shape, and it would be

difficult, or impossible, to determine an anthracite from a coke iron by the fracture. The two irons present a similar appearance and, as foundry iron, are so near alike it would be useless to describe anthracite iron in detail after having described coke irons.

SILVER GRAY IRON.

Silver gray iron is a foundry iron sometimes produced by furnaces when overheated, and has been called a burned iron. This iron was never a regular furnace product, but was a chance product, and generally sold at a very much reduced price from the regular or standard iron of the furnace. It was occasionally seen in foundry yards some 25 years ago, but was never sufficiently plentiful to come into general use.

The writer has not seen it or learned of its being used for many years, and since the improvements in blast furnace practice, it may not be made.

The fresh fracture of this iron in the pig was very similar in appearance to that of a white iron, and was only distinguished from white iron by the silvery gray cast from which it derives its name.

The iron was very soft, ran fluid, and presented many of the characteristics of high silicon iron of the present time. It was very weak and unsuitable for castings when melted alone, and was used as softener when melting the lower grades of pig or scrap iron.

HIGH SILICON IRON.

Silicon is an element that enters freely into combination with iron. It is found in combination with iron in its native state in large proportions, and may be added to iron in the blast furnace. Great beds of iron ore containing this element in large proportions have been found in this country that are very accessible, and by reason of the softness and brittleness imparted to them by the silicon, they are easily mined and broken up, and a cheaper iron is made from this ore than many others.

The iron produced from this ore is of an inferior quality.

Rolling-mill men and the manufacturers of steel have no use for it, and it is being pushed forward as a foundry iron.

The only requisite quality this iron possesses as a foundry iron is weight, and this quality is offset to a large extent by its rottenness. When cast into sash weights, or other slender weights, they must be handled with care to prevent breakage.

Silicon in large proportions imparts to iron a peculiar grit that removes the edge from a finishing tool about as rapidly as a grind-stone. It also reduces the chilling tendency of cast iron, and is claimed by the advocates of silicon iron to be a softener; but I think this is a mistake, and that carbon will yet be found to be the true softener. But this iron, as before stated, is being pushed forward as a foundry iron, and as the writer has melted many tons of it in various proportions, a few suggestions on melting and mixing it may be of value to foundrymen.

The proportion of silicon that may be used in a foundry iron without impairing its quality to any great extent varies from $\frac{1}{2}$ to 3 per cent., according to the kind of casting the iron is to make; thus a mixture for heavy machine castings requiring great strength needs none of this iron. Light machinery castings to be finished may require from $\frac{1}{2}$ to 1 per cent., and stove plate, bench work, and other light, thin castings, from 2 to 3 per cent. This percentage of silicon reduces the chilling tendency of the iron, and prevents to a large extent hardness on thin edges, and at a distance from the runner or gate.

To distribute this per cent. of silicon evenly throughout the castings when a high silicon iron is used in a mixture with a low grade of pig or scrap, requires very nice cupola practice.

The aim must be to get the small per cent. of high silicon iron evenly distributed throughout the large per cent. of other irons when in the molten state. This can only be done by careful charging and tapping.

When all pig is melted with only the foundry scrap, the high silicon iron should be broken in pieces that will admit of it being mixed with the other pig; and when charged, care should

be taken to not place the silicon iron all together, but to distribute it evenly throughout the other pig, so that when melted it may have the opportunity to mix with the other iron in its descent through the fuel to the bottom of the cupola and be more evenly distributed in the molten mass at the bottom. The iron should be melted very hot and the cupola not tapped close, or a small tap hole made and a considerable body of iron permitted to remain in the bottom of the cupola, when a continuous stream is drawn. It will also be found of advantage to place a large ladle holding from 500 to 1,000 on trestles in front of the cupola and pour the iron from this ladle into hand or other small ladles for light work.

When melting heavy scrap and high silicon pig, the same precaution should be observed to insure a homogeneous iron.

When melting light scrap and high silicon pig, such as that recommended to carry 90 per cent. of scrap, the silicon iron should be broken in very small pieces and mixed with the scrap in charging in a way that will insure the pig and scrap melting at the same time, and mixing as they descend and also in the bottom of the cupola.

This would not be the case if the pig was all charged on the fuel with the light scrap on top of it, unless the entire charge was melted before a tap was made. When melting this grade of irons the precaution should always be taken to mix the iron in a large ladle as well as in the cupola.

Pig irons are now being made for foundry work that contain from $\frac{1}{2}$ to 3 or 4 per cent. of silicon, and foundrymen will secure a more homogenous iron for their castings by purchasing an iron that contains the amount of silicon said to be necessary for their grade of castings than by purchasing an iron very high in silicon and mixing it with an iron very low in silicon, or free from it.

When castings are deficient in strength, and breakage is heavy in the tumbling barrels, or in the handling, the silicon should at once be reduced by increasing the irons low in silicon in the mixture.

When the iron in finished work leaves the tool of a lathe or planer like particles of half dried sand and, readily crumbles into small particles, the silicon is too high. Such iron generally takes the edge off of tools very rapidly, is difficult to finish smoothly, and if finished for small shafts, cuts out bearings very rapidly, or if finished for bearings, cuts the shaft.

SCOTCH PIG.

Scotch pig is the common name by which numerous brands of pig iron imported from Scotland are known in this country.

Thirty or forty years ago this iron was extensively used as a foundry iron, and many founders believed they could not make soft castings without Scotch pig. At the present time its use is restricted almost entirely to seaport cities and towns, to which it is brought by vessels as ballast, and sold at a less price than American foundry irons.

The iron is cast into short, thick pigs, the fresh fracture of which is of a dark bluish cast, with the large crystal called an open iron. It is high in graphite or free carbon, and when broken small flakes of graphite frequently fall from the fracture. The iron is deficient in strength and the large pigs are easily broken with the sledge. The qualities of the different brands of Scotch iron vary to a considerable extent, and the price varies from one to two dollars per ton, according to the quality and reputation of the brands.

The best brands run very soft and clean in light work, and some years ago were the only irons used for stove plate and hollowware, but they have generally been replaced for this work by the stronger soft brands of domestic irons.

Some of the poorer brands run soft but so kishy that it is difficult to make perfect castings from them, the kish collecting in spots on the surface of the castings, making thin spots or holes, and in heavy work collecting in short angles or edges, causing rounded and uneven corners or edges. Other brands run very dirty, as well as hard, and are only fit for weights or very common castings.

NOTE.—Kish is a name given by founders to a soft, dark substance resembling black lead, that is forced out of a very soft iron when in a molten state and when cooling. In thin castings it runs before the iron in the mold and causes rounded edges or corners, similar to those made by blacking, dusted on too heavy, and washed before the iron. In heavy casting it collects on the surface in spots, and around the edges. It adheres firmly to the casting, but is soft and easily broken off, leaving a smooth surface. Kish is only found in very soft iron, in which the softness is due to graphite or free carbon, and comes from an excess of this element in the iron. Kish is not found in foundry irons used at the present time to the same extent it was in those used some years ago, and many of the younger founders have probably never heard the term.

AMERICAN-SCOTCH FIG.

When the Scotch pig craze was at its height a number of furnacemen in this country, with the usual American inventive genius, conceived the idea of imitating Scotch pig, and a number of brands of iron were made and put on the market called American-Scotch pig.

These irons, in many cases, were far superior as foundry irons to the genuine Scotch, and in numerous cases soon replaced it in foundries making light work, for which it was claimed only Scotch pig could be used.

Among the brands of American-Scotch that attained a high reputation were Briar Hill and Cherry Valley. The writer has melted many tons of these irons for light as well as heavy castings and found them to run as soft as any brand of Scotch pig he ever melted, and far superior to them in cleanliness and strength.

There were many other brands of American-Scotch in different sections of this country that attained a high reputation, and are still in the market as foundry irons; but as Scotch pig is not in demand to the extent it was some years ago, furnacemen have generally dropped the term American-Scotch, and the irons are known only by their local or furnace names.

FOUNDRY PIG.

This is the name generally given to pig iron made in the foundry from piles of refuse iron that have collected about the foundry or yard, and are melted at the end of a heat and run into pigs to get the scrap out of the way and in a shape to be melted with other irons in the regular heats. This iron is generally gangway or cupola scrap that has been allowed to accumulate, or burnt iron and other refuse that has been thrown out of the scrap pile.

This scrap makes a very inferior pig iron that will not mix when remelted with either pig or scrap iron to make a homogeneous casting. The poorest brand of pig iron the founder has to contend with is his own make of foundry pig. When he has once made a good-sized pile of it he generally has pig iron in the foundry yard as long as he is in the foundry business.

PIG IRONS.

Since the earliest period in blast furnace practice pig iron has been cast in sand moulds, and the greater part of it is still cast in this way.

This iron received the name of pig iron, but since the introduction of other modes of casting the term pig iron has become a general one, applicable to all the various modes of casting, and terms have been adopted to indicate the manner of casting.

In accordance with this new mode of classification, iron cast in sand mold is designated sand pig; in chills, chill pig; and in the latest device of chills sandless pig.

Each of these modes of casting has its advocates, and various advantages are claimed for them as foundry irons.

In the casting of sand pig and also chill pig, the molten iron is drawn direct from the furnace into a runner and distributed through the sow-pig to the pig mould.

It is claimed that in this mode of casting the irons smelted from various ores are not thoroughly mixed, and an even grade of iron is not obtained throughout the cast. It is also claimed that the sand adhering to the pigs renders the iron dirty when

remelted for casting, and also that sand adhering to the pig makes it more difficult to melt.

In the chill pig the same unevenness in the cast is claimed, and a heavy chill on the pig is objectionable.

That a variation in the quality of the cast exists has been clearly proven by analysis, but this objectionable feature has for many years been overcome by mixing irons from various parts of the cast when remelted, and an even grade of iron obtained in casting.

That sand adhering to the pig enters into combination with the iron when remelted and renders it dirty is pure nonsense. For iron is smelted from ores containing as high as 80 per cent. foreign matter, and a clean iron obtained from a blast furnace, and in cupola practice foundrymen frequently have as high as 50 per cent. of remelt iron which is often melted without milling or cleaning, and to such small scrap a hundred per cent. more sand adheres than to an equal weight of pig iron, and yet this mode of melting has not been conducive to dirty iron in castings.

That more time and fuel are required to melt pig heavily coated with sand is a fact well known to founders, and that this may be overcome by breaking the pig into short pieces, so that it may melt from the end, is well known.

But founders have not found the excess of fuel and time required to melt pig sufficient to pay for breaking it, or in the case of remelt scraps to pay for cleaning it.

All these objectionable features in the sand pig have been overcome in the sandless pig. This pig like the chill pig is cast in iron molds, is only one-half the length of the sand pig, and like it the pigs vary in size according to the fancy of the furnacemen, and vary in weight to from 40 to 80 pounds.

In casting these pigs, the runner to the mould is dispensed with and the iron caught in a ladle of a sufficient size to hold the entire cast, and is poured from the ladle into the molds which are placed upon a revolving table or an endless chain device, arranged so that pigs may be dumped from the mold

as soon as the iron is set. By this means the molds are kept hot and their chilling effect upon the iron reduced to a minimum.

It is claimed that the catching of the iron in a ladle effects a more perfect mixture, and that a more homogenous iron is obtained than when iron is permitted to flow to a pig bed from a furnace, and a pig free from sand and cleaner is obtained.

These claims have been fully proved by analysis and inspection, but no better castings have been obtained from this pig than from either of the other pigs when properly mixed and melted; but with poor cupola management and careless charging a more even iron may be obtained than with the others.

The casting of this pig is in the line of foundry chemistry, and has only been in vogue for a few years, and only a limited number of furnaces have fitted up their plant for casting it. But if the expense for casting is not found to be too great it is destined to become the leading form of foundry pig.

The principal objection found to this iron by founders has been the size of the pig and the chill on its surface from contact of the molten iron with the mold in which it is cast.

The size of pig, when weighing 70 or 80 pounds, and only about 18 inches long, is certainly an objectionable feature. It is not convenient for handling and charging, is difficult to break, and not well adapted for mixing with other irons, especially in small cupolas and with light heats. But these objections may be overcome by making the pigs smaller so that they may be readily handled or broken. The objection to the chill on the surface is from the well-known tendency of molten iron to harden when suddenly cooled by contact with solid iron. The hardening of iron in this way depends upon the quality of the iron. In very soft iron the chill is very light; in hard iron it is heavier, and with cold blast charcoal iron a chill of half an inch to an inch may be obtained; but all these chills disappear when the iron is remelted and no trace of them can be found in castings from chilled iron when remelted.

CHAPTER X.

MELTING AND MIXING FOUNDRY IRONS.

THE object in melting iron in a cupola in a foundry is to make castings and not scrap, and that this result may be obtained we have endeavored in this chapter to give in detail various experiments made in the melting and mixing of irons which founders are required to melt in their daily practice, and with which they occasionally come in contact and are at a loss to know what to do with, and to outline the best methods of melting or disposing of such irons.

That the best results may be obtained and an even or desired grade of castings may be produced, it is absolutely necessary that iron, no matter of what quality, should be properly melted. This may be done in any cupola, no matter how old fashioned or modern, if properly managed. And it cannot be done in any cupola if not properly managed. As even a grade of iron is being drawn to-day from old fashioned cupolas, many of which are still in use, as from the most improved ones. And it is only when a cupola is run beyond its capacity that an even grade of iron cannot be melted. Quantity and not quality of iron is therefore the only matter that should be taken into consideration when deciding upon placing a new cupola in a foundry, for no better grade of casting will be obtained from a new one than from the old under the same system of management.

That iron may be of an equal grade throughout a heat, it should be melted at an even temperature and regular speed. That this can be done has been clearly demonstrated in foundries making stove plate and other light work in which heats of many tons are melted without an apparent variation of

temperature of iron or size of stream melted from the beginning to end of a heat.

That this is the proper way to melt iron has also been clearly demonstrated in these foundries, for in no class of work is quality of iron more quickly ascertained or the effect of uneven temperature in melting more readily seen than in this work.

Iron melted rapidly and at an even temperature produces an even grade of castings throughout a heat. While the same iron melted at an uneven temperature, even when the variation is slight, produces castings of an uneven degree of hardness, strength and shrinkage.

And the same is the case no matter how heavy the class of castings, and we may find castings made from the same pattern, in the same heat, having different degrees of hardness, shrinkage, density and strength, due to uneven melting or temperature at which iron is poured. To avoid this, it should be the aim of every founder to have his iron melted hot and fast, and of an even temperature, from the beginning to the end of a heat, and poured hot.

Of no less importance than the melting of iron is the mixing of various grades of iron to be cast into one iron. The theory held by many founders that irons mix to form a homogenous mass, no matter how they are brought together, is all wrong, as has been clearly demonstrated by attempts made to mix large and even comparatively small bodies of molten irons possessing entirely different characteristics, due to the different metalloids or per cent. of various metalloids they may contain.

To avoid bringing large bodies of the various grades of iron together in a molten state and having them form distinct layers in a ladle or mold, they should be mixed when placed in a cupola in such a manner that when melted they will come together drop by drop in their descent to the bottom of a cupola. This may be done by placing the various grades of iron in a cupola side by side, and the shorter they are broken the more thoroughly they may be mixed. Light scrap should be placed on the top of the pig or other heavy iron, that when melted it may be mixed with that from the heavy iron.

When melting pig and light scrap, the charges should be divided into drafts, and only a sufficient amount of pig or heavy iron placed upon the fuel to cover it; on this pig only sufficient scrap to cover the pig, and the next draft of pig should cover the scrap, and so on until the charge is all put in. Fuel should then be charged, and each charge of iron mixed in the same way.

That irons may be thoroughly mixed when brought together in a molten state, they should be kept in motion from the time they are melted until they reach their final destination—the mold.

A cupola should never be stopped in from the time the blast is put on until the bottom is dropped, and should melt a steady stream of an even temperature from the beginning to the end of a heat. And iron when drawn from a cupola should be at a white heat, and sufficiently hot and fluid to run the lightest of castings. This is the only way an even grade of iron can be drawn from a cupola, and every founder should arrange to melt and handle his iron in this way, no matter how heavy their castings.

MELT IRON HOT.

Many foundrymen, as well as the molders themselves, do not seem to know what hot iron really is, and call any iron that will flow from a ladle hot iron.

An iron when reduced to a molten state is, of course, a hot iron, but a molten iron may not be a hot or fluid iron in the foundry sense of the term. By this term is meant an iron that is sufficiently hot and fluid to cast the lightest or heaviest of castings, and produce a clean, sharp casting, an exact facsimile of the pattern.

To obtain such an iron it should be melted rapidly and hot, and when drawn from the cupola should be at a white heat, even if the work to be cast is heavy, and when poured into a mold should be at as near this heat as the character of the work will admit of.

This will, no doubt, seem to founders a radical statement, and also to molders who have always been in the habit of melting their iron dull or chilling it down in the ladle before pouring, until it has scarcely sufficient fluidity to fill a mold properly. These men will, no doubt, at once say that molds will not stand such hot iron, the sand will cut, facings burn, and castings not scale, etc. To such men we would say that the output of a foundry is not molds, but castings, and molds should be made to suit castings and not castings made to suit molds.

There are sands, loams, facings, blacking, etc., that resist almost any degree of heat in molten iron; such materials may be obtained from any of our leading foundry supply houses, and it is only necessary for the founder to make known his wants to any of these concerns to obtain materials suitable for the work to be cast, and these generally cost no more than inferior articles.

In all cases material should be used that will stand hot iron, and iron should be poured hot and molds filled rapidly. This is the only way to make a sound, clean casting. Some deviation may be made from this rule when casting very heavy work that requires to be fed up, but a sufficient leeway is generally made by the iron, for when casting such work some time is required to fill a ladle, and during this time the iron is generally cooled to a sufficient extent for pouring by the time it reaches the mould.

Many founders are under the impression that iron when melted fast and very hot is burned in melting, and endeavor to not melt iron very fast or very hot. This theory is entirely wrong, and the reverse is the case. Iron melted slow and dull is burned and hardened in melting, and may be entirely ruined for the work to be cast by such melting.

This is another statement that will no doubt be criticised by many old founders, as well as younger ones, who have followed in the footsteps of the old founders, and been taught the dull iron theory of melting. But the statement is none the less correct, and founders who doubt it have only to make a little inquiry to find it to be so.

There are no founders who require a better grade of iron for their work than the stove and bench work foundries. In these shops iron must be very hot and fluid to run the castings; and when it flows from the cupola it is in many cases heated to as high a degree of heat as iron can be heated to in a cupola. If the iron was burned in melting, or presented any of the characteristics of a burned iron after casting, it could not be used for this class of work.

Cast iron is not a pure iron, but a compound of iron and various metalloids, which impart to the iron its characteristics, and give to it the various degrees of hardness, softness, etc., found in cast iron. When these metalloids are removed, or their combination with the iron changed, the characteristics of the iron are changed, and to produce an iron when cast, having the characteristics of the iron before melting, it is necessary that the iron should be properly melted, and cast in a way that will prevent the removal of metalloids or their liberation from combination with the iron; for the removal of metalloids produces a harder or softer iron than the original iron, and their liberation from combination with iron, without removal from it, makes a dirty iron.

Some of the metalloids enter freely into combination with iron, and are removed with difficulty, while others are readily set free from their combination with iron, and it is only when the iron is in a very hot and fluid state, as a foundry iron, or in a solid state, that they are not readily set free by agitation of the iron.

When iron is melted slow and dull it is slowly heated to the melting point, and is melted from the outside, and every part exposed to the heat and action of the blast; it is not melted, but is reduced to a molten state by burning off the exposed surface.

The metalloids are exposed to the action of the heat and blast, and those, having but a limited affinity for iron, are readily removed from it in melting, and the character of an iron may be, and frequently is, entirely changed when melted in this

way, which accounts for a hard iron being obtained at the spout when a soft iron has been charged.

When iron is permitted to cool in a ladle, dirt and dross will continue to rise to the surface as long as the iron remains sufficiently fluid to permit it to rise; and the more it is agitated or stirred the greater the amount of dirt that rises to the surface. This dirt is metalloids set free from combination with the iron as it changes from a molten to a solid state.

Were this not the case, and the material that rises to the surface were actually dirt in the iron, it would rise more freely from a very hot iron than from a dull iron, which is not the case, as a scum does not accumulate as rapidly on the surface of a very hot iron as on dull iron; and lumps of dirt never rise to the surface of hot iron save when set free from the lining of the ladle.

When iron is cooled in a ladle and poured dull, these metalloids are set free by flowing of the iron into the mold, but cannot escape from it as they do to the surface in a ladle, but are retained in the iron and collect in spots in a casting, making a dirty casting.

The same results are produced when a comparatively hot iron is poured through a very small gate and a mould slowly filled, and also when poured through a complicated skim-gate, which only admits of a slow filling of the mould.

When iron is properly charged in a cupola, it is prepared for melting by being heated while settling to the melting zone, and when it enters this it is melted in a mass. The metalloids are not exposed to the action of the heat and blast to the same extent as when melted slowly from the outside, just above or below the zone, as is the case in slow melting.

When iron is melted in a mass in the zone, and flows from the cupola at a high heat, the iron and metalloids are in a state of chemical combination, and if changed from a molten to a solid state without being disturbed when cooling, they remain in this condition, and a clean iron is obtained.

Iron should therefore be melted hot and poured hot, that it

may be placed in the mould with the metalloids in combination with the iron, and permitted to cool in this condition.

MIXING IRONS.

There is a general impression among founders and molders that different grades of iron, when brought together in a molten state, mix and enter freely into combination with each other, forming one homogenous mass. Under this impression, cupolas have been especially designed for mixing irons by collecting a large body of molten iron in the cupola before tapping. That this impression is erroneous, and that different grades of iron do not mix by merely being brought in contact with each other in a molten state, is clearly proven by the iron drawn from blast furnaces, in which molten iron is permitted to collect in the furnace crucible for from six to twelve hours, the length of time depending on the size and working of the furnace.

It is the custom to tap the furnace after a certain number of charges of ore, fuel, etc., have been placed therein, this having proved to be the best guide furnacemen have as to the inside working of the furnace, and indicating when the crucible is full. During this time the crucible is slowly being filled with iron smelted from the ores, and the iron is not drawn from the furnace until many tons have collected in one molten mass.

Yet careful analysis has shown that the iron, when drawn from the furnace and cast into pigs, is not of an even grade throughout the cast. This indicates that irons smelted from different grades of ore do not enter freely into combination with each other when brought in contact in a molten state, and even when permitted to remain in contact in this state for many hours.

This being the case, it is useless to place tuyeres high in a cupola for the purpose of collecting iron in a cupola to mix it before tapping, for the extreme length of time a rapidly melting cupola can be allowed to remain without tapping is probably fifteen or twenty minutes. If molten iron is not mixed in a furnace crucible in from six to twelve hours it is not at all likely

that the same irons will mix in fifteen or twenty minutes when remelted in a cupola.

Fluid bodies are not readily mixed by merely being brought in contact with each other, but may be rapidly and thoroughly mixed by being put in motion.

If we take two or more different colored waters and carefully place each of them in a considerable body in a bottle in such a way as to not mix when placed in contact with each other, they will remain separate and distinct for many hours, only slowly blending with each other; but if after bringing them in contact with each other in this way, we pour the contents of the bottle from one bottle to another a few times, the color of each water disappears, and a new color is formed in a minute that would have taken hours to produce had not the water been put in motion. If in place of bringing the colored waters in contact in a large body we bring them together in drops, the identity is at once lost, and a less motion is required to thoroughly mix them.

The same is the case with molten iron, and by bringing the different grades together in drops and putting them in motion by drawing the iron from the cupola at once, a mixture is effected with less motion than when the iron is permitted to remain in the cupola, and the different grades as melted are permitted to drop into several pools by themselves in a mass of molten iron, only to be mixed with each other when drawn from the cupola.

Two totally different metals may be mixed to make an apparently perfect mixture when in a molten state, but they separate to a greater or less extent when solidifying, and each retains its identity. This is the case where two totally different irons, such as a highly carbonized iron and a highly oxidized iron are melted together, and accounts for the small nodules of white iron sometimes found in iron when a very soft iron and a burned iron are melted together.

A less number of these nodules are found when the irons are brought together in small particles or drops than when brought

together in large bodies, and may by careful mixing be made to entirely disappear if the oxidized iron is not melted to excess.

It should be the aim in charging to place the different grades of iron in a cupola in such a way that when melted they may be brought together in small bodies in their descent through the fuel after melting, and also at the bottom of the cupola, and not to melt them separately and distinct, and to allow each to descend to the bottom and form in separate masses or pods, only to be mixed when drawn from the cupola.

This can only be done by breaking the pigs into short pieces and mixing the various grades when charging by carefully placing the different grades in contact with each other in small pieces, so that when melted they will come in contact as they trickle through the fuel to the bottom of the cupola.

This precaution should not only be taken when melting different brands of iron, but also when melting only one brand; for it has been shown by analysis, and also by fracture, that two or more grades of iron may be found in the same pig. And by melting the two ends, or different parts of the pig in contact with each other, and permitting the iron from each to mix as melted, a more even iron is produced.

When mixing irons to obtain a certain quality of iron from the mixture, better results are obtained by mixing irons having as near the properties required as can be obtained, than by trying to produce it from two extremes, such as making a medium hard iron from an extreme soft and extreme hard iron, by mixing them in certain proportions; or making a medium strong iron from an extreme strong and an extreme weak iron.

Opposite extremes in iron do not mix well, and in making mixtures we should avoid melting them together, as is frequently done under the impression that a small amount of very hard iron is softened by a large amount of soft iron, and *vice versa*.

A small amount of hard iron would no doubt be softened and made to entirely disappear in a large body of soft iron, if minutely divided and thoroughly mixed with the soft iron, but

if this is not done and the irons are brought together in a considerable body, each retains its characteristics, and the hard iron may be found in the soft, as a hard spot in a casting. And hard spots can frequently be traced to small pieces of very hard iron placed in the cupola with the scrap.

To thoroughly mix irons they should be kept in motion from the time they are melted until they are poured into the mold. This can only be done by making the tapping hole of a size that will admit of the iron flowing from a cupola as fast as melted and running a continuous stream from the cupola. This is the common practice in stove-plate and bench-work foundries, and a more even iron is made in these foundries than in any other.

When hand ladles are not used and the iron is handled in small bull ladles, a broad-topped, shallow mixing-ladle that will admit of a ladle being filled from it, while the stream from the cupola is running into it, should be placed under the spout and the iron poured from this ladle into the pouring ladle.

When work is heavy and only large ladles are used, they should be placed under the spout and filled with a continuous stream; or the iron placed in them from the mixing ladle with small bull ladles. In either way the iron in the large ladle is not permitted to remain at rest until the ladle is filled.

To promote the mixing of irons, they should be melted fast and hot, for two semi-fluid bodies do not mix as readily or as perfectly as they will when in a very fluid state. This may be illustrated by mixing two oils when cold and the same oils when heated. The more fluid we can make the different grades of iron when melted, the more readily they will mix with each other.

Iron when drawn from a cupola should be at a white heat and sufficiently fluid to run the lightest of castings, and should be poured hot to produce a perfect casting and an even iron throughout same.

When mixing iron for a certain grade or class of work for which a soft, strong iron is required, a mixture of irons con-

taining these properties should be made, and in mixing iron for castings in which hardness is required hard iron should be selected.

CAST IRON IN FOUNDING.

Cast iron is a compound of iron and metalloids, the exact number or nature of which has not yet been fully determined. It is not my purpose to treat of the various metalloids or their effect upon iron, but to treat of the compound as a whole, in its application to the art of founding.

Metalloids are found in combination with iron in its native state, and may be added to it when smelted in a furnace, from fuel, fluxes, etc. They give to iron the various characteristics found in cast iron, such as hardness, softness, weakness, strength, chilling tendency, etc. When a casting is to be made, it is the practice of founders to select an iron containing metalloids that give to the iron the requisite qualities required in the casting. When such iron is not obtainable, it is the practice to mix two or more irons that the metalloids, when blended together in melting, may produce an iron having the qualities required for the casting.

As all founders are not familiar with the term metalloids, I will endeavor to state the matter in more familiar foundry terms. When a casting is to be made, an iron is selected having the qualities required in the casting, as indicated by analysis, fracture, or previous experience in melting the iron. When such an iron is not at hand, a mixture of two or more brands of pig Nos. 1, 2, and 3, or a mixture of pig and scrap, is made to produce, when melted together, an iron having the desired qualities. To produce such an iron from one or more irons, it is necessary that the metalloids or elements that give to the iron or irons their characteristics, shall be retained in the iron, after it is cast. If this is not done, then analysis, indications of fracture, or previous experience with the iron, is useless as an indicator of results, and this can only be done by the proper melting and casting of the iron.

The metalloids or impurities, as they have long been called, are removed from cast-iron by a high degree of heat, as illustrated in the making of steel by the Bessemer process, and are also removed by prolonged degree of heat, just above the melting point, and agitation of the metal, as illustrated in the puddling of iron, in the manufacture of wrought iron. With the high degree of heat we have nothing to do when melting iron in a cupola furnace, for the highest degree of heat obtainable in such a furnace is not sufficient to remove from cast iron any of the metalloids that affect the character of the iron. It is the low degree of heat, as illustrated in the puddling furnace, we have to deal with.

The puddling furnace is a reverberatory furnace, and in it iron is not melted in contact with the fuel, but by the flame from the fuel being passed over the iron by a forced blast or draught of a high stack. The metalloids are removed from the iron by the flame to some extent, when the iron is being melted, and fully removed by stirring or puddling the iron when in a semi-fluid state, and exposing every part of it to the flame.

In a cupola, iron to be melted is placed in direct contact with the fuel, and is melted with a forced blast. The blast, after being forced into the cupola through the tuyeres, is heated by the fuel in the bottom of the cupola, and at a certain point in a cupola enters fully into combination with the carbon of the fuel, and produces an intense white heat without a flame. This point in a cupola is known as the melting point or zone; above this zone a flame is produced from the fuel by the heat. This flame removes metalloids from iron upon the same principle and to a similar extent, to that of a puddling furnace when iron is melting, and when subjected to it for any length of time in melting, metalloids may be removed to a sufficient extent to entirely change the character of the iron.

Iron is subjected to this flame by the use of an excessive amount of fuel, which places it above the melting zone and supports it there until the fuel is consumed, and permits it to descend into the zone. The length of time iron may be subjected

to this flame depends upon the excess of fuel used and the kind of fuel. When melting with anthracite coal we have seen iron supported above the melting zone for from half an hour to an hour in the flame, and from two to three hours in a cupola, before descending into the flame or zone. All this time it was being heated, and when it descended into the flame was heated to a sufficient extent to be readily affected by the flame.

Iron, when subjected to the flame in a cupola, is slowly melted from the outside, and every part of it is exposed to the flame as it melts away. That metalloids are removed from iron when melted in this way, there is no doubt, for we have seen a mixture of soft Scotch pig and No. 1 soft American iron run too hard for the work to be cast, when melted high in a cupola, and the same iron run too soft and kishy for the work when a proper amount of fuel is used, and the iron quickly melted in the melting zone, and scrap had to be added to the mixture to give the castings a proper degree of hardness and strength.

To retain the metalloids, and obtain an iron having as near as possible the characteristics of iron before melting, the iron should be melted rapidly and hot in the melting zone. This can only be done by the use of a proper amount of fuel for the bed and charges, and placing the exact weight of iron on the bed and charges that will melt hot and fast. No two cupolas melt exactly alike, and the amount of fuel to be placed in a bed and in the charge must be learned by experiment, and the amount of iron that can be melted on the bed and charges found in the same way.

After having melted iron in a way that will prevent metalloids being removed in melting, the next important matter to be considered is the best means of retaining them in the iron, evenly distributed through it when the iron is cooled again. This can only be done by a proper handling of the iron when in a molten state.

When we draw from a cupola a ladle of iron at white heat, the metalloids are in combination with the iron, and the surface of the iron in the ladle is clear as a crystal; no dirt or dross is

found upon it, save that which may be washed from the spout by the stream or was in the ladle before filling. If we permit this iron to remain in the ladle until it sets, as its temperature is reduced a scum collects on the surface and pieces of dirt or dross may be seen to rise to the surface as long as the metal remains in a fluid state. And the greater the length of time the iron is in cooling from a molten to a solid state the larger the amount of dirt and scum that collects on the surface. This dross and dirt is the metalloids that have separated from the iron in cooling, and the amount of dross is greatly increased by stirring or agitating the iron while cooling. To prevent the separation of metalloids, the iron should be changed from a molten to a solid state as rapidly as possible, and without being agitated while changing from one state to the other.

This may be done by taking the iron direct from the cupola to the mold, and pouring it into the mold at the highest possible temperature. The iron then reaches its ultimate destination at a high temperature, and is placed in a condition to be cooled rapidly without being disturbed when changing from a molten to a solid state. The metalloids have not the opportunity to separate they have when the iron is reduced to a semi-fluid state in a ladle before pouring, and a strong, clean, even iron is obtained in the casting.

On the other hand, if we melt the iron dull, or cool it in a ladle before pouring, the metalloids separate to a greater or less extent, and when the iron is poured they collect in spots, and a dirty casting is produced from the same iron that a clean casting may be made from if the iron were poured hot.

SHOT IRON AND HARD SPOTS IN CASTINGS.

There are numerous small particles of molten iron which fall from the cupola spout to the floor when tapping out, stopping up and changing ladles. Iron is spilled from ladles in the gangway by careless molders, when carrying them; small particles are frequently spilled on the top of molds when pouring, and many small particles fall from the cupola when the bottom is dropped.

This iron when collected is designated in different foundries as shot iron, gangway scrap, foundry scrap, cupola scrap, tumbling barrel scrap, etc. In describing it, we shall designate it by its more common name, shot iron, and include in it all very small scrap from a foundry, such as shot, fins, vents, shells from runners, ladle skulls, etc.

Shot iron is collected from the dump when cold by breaking it up and carefully picking it over to recover the iron. In this way of recovering the iron, many or all the smaller particles are left. In foundries in which tumbling barrels are used, the entire dump is generally broken up and thrown into the barrels, with castings to be cleaned, or into a tumbling barrel kept for tumbling the dump. When put in with the castings, many small particles of iron are lost by passing through the large holes in the staves, or cracks between them. When a barrel is kept for the dump the openings are generally made smaller for the escape of the dirt and cinder, and more iron is recovered.

Shot and other light scrap from the top of flasks is collected upon a shovel and thrown into the gangway or dumped into the sand heap by careless molders and recovered when riddling sand for a mold and thrown out. Shot from about the cupola spout and gangways is collected by scrapping or sweeping up the floors and riddling this or putting it in the tumbling barrel with the dump. When riddled, a number two riddle is generally used, and all the small particles of iron are lost that are recovered, when the refuse is thrown into a close tumbling barrel.

A machine has been invented and is now in use in some foundries, for recovering every particle of iron from foundry refuse.

The dump and other refuse is first broken up and cleaned in the tumbling barrels, and the smaller particles of iron, escaping from the barrels, are recovered by passing the refuse from under the barrels through a machine consisting of an ingenious combination of vibrating screen and fan, for extracting all shot and other small iron from the refuse.

A barrow full of refuse will pass through the separator in three or four minutes, all the iron being deposited in a box provided for it and all other material thrown to the rear of the machine. We have seen this machine in operation and it does its work to perfection. Founders who believe in saving every particle of iron can do so by putting in one of them.

Some founders endeavor to recover every particle of iron from foundry refuse, others only recover the larger pieces, and permit the cupola dump and also gangway cleanings to be thrown in the dump, without first recovering the small iron.

Let us see which of them is the best off in the end.

Shot iron from the dump is hardened to some extent by rapid cooling of the dump by water, and is annealed by slow cooling and softened to a considerable extent.

To prevent the hardening of this iron, some foundries only permit a few buckets of water to be thrown on to deaden the surface, and permit the dump to cool slowly.

Shot from the gangways is hardened to a perceptible degree by sudden cooling in the open air, and partakes of the characteristic of the iron from which it was made. That from very soft iron is soft, but hardened to some degree. That from an iron inclined to run hard is white all the way through, or shows a white outer edge. By noticing the character of iron in shot on the top of molds, an accurate idea of the quality of iron in the casting may be formed, especially in light castings.

To restore gangway shot, vents, etc., to their former condition, they are sometimes, after being cleaned, thrown on top of the cupola dump and permitted to anneal over night, then thrown in the tumbling barrels and recovered with the dump scrap. It is doubtful if this restores the iron to its former condition, although it is softened to a perceptible degree when the dump is of a sufficient size to retain its heat for any length of time.

This was the common practice, some years ago, in foundries making fine castings from charcoal iron, costing from forty to fifty dollars per ton.

Founders have always, to a greater or less extent, been troubled with hard iron, and among the numerous causes assigned for it, is that of shot iron hardening other irons when melted with it.

To prevent this iron hardening other irons, various plans have been devised for melting it; among them, the melting of shot at the end of a heat, or in a heat by itself, and run into pig to be melted with other iron in the regular heats.

A device was patented a number of years ago for melting shot, consisting of a cast iron pot or tube with a device for tightly closing the end with a cast cover to exclude the blast of the cupola. It has also been melted in tight wooden boxes, open pots, and enclosed in iron by placing it in pig molds, and pouring molten iron upon it, in such a way as to inclose or imbed it in the pig.

It has been found that the quality of shot iron is not improved by melting it at the end of a heat, or in a separate heat, or running it into pig, but is deteriorated by so doing, and does not mix with other irons as well after being run into pig as when in its original state.

This is more especially the case when the iron is melted in a separate heat, for the reason that some time, and perhaps months, are required to collect a sufficient quantity of it for a heat. During this time the iron becomes heavily coated with rust, which greatly deteriorates its quality as well as the quantity of iron in the shot before it is melted, and produces an inferior quality of iron to that obtained from new shot free from rust.

The melting of an entire heat of shot iron is a very unsatisfactory operation. The fine iron packs so close that the blast cannot penetrate it in any great volume, and is thrown back upon the blower. In case of a forced or positive blast, the belts are either thrown off or the blast finds a few openings through which the greater part escapes, and in either case the melting is slow, and many small particles of iron become imbedded in the cinder and slag around the cupola, and have to be recovered from the dump.

It might be as well to say something about the recovery of iron from foundry dumps here as elsewhere, as this iron comes under the head of shot iron, as we have classified shot iron in describing it.

RECOVERING IRON FROM FOUNDRY DUMPS.

Founders who come into possession of foundry plants that have been run by others for a number of years frequently find in the foundry dump a considerable quantity of iron which may have been placed there by careless workmen, or by the old management for unknown reasons. The new management frequently undertakes to recover the iron under the impression that its loss was due to the extravagance or carelessness of the former management, which is not always the case.

Jesse Star, when running the Camden Iron Works, one of the largest pipe foundries in this country at the time, threw the cupola dump and gangway cleanings in the foundry dump after recovering only the larger pieces of iron.

When a new management took charge of this works, they discovered this supposed extravagance, and a gang of men were put to work to recover the iron, many tons of which were taken from the dump, melted and run into foundry pig for future use in the regular heats. This iron was soft iron suitable for pipe work when consigned to the dump, but had lain in the dump for a number of years, and had become oxidized or heavily coated with rust, and when melted and run into pig was very hard. The pig, when melted with other pig, would not mix with other irons to make a soft or homogeneous casting. This was probably due to a change effected in the iron by oxidation while in the dump.

After numerous attempts to use the iron in various ways, resulting in the loss of many castings, it was piled in the foundry yard, where it has remained for probably twenty years. A fair sample of foundry pig, the iron was only fit for weights, and was not worth half its cost to recover it, even with pig iron at a high price.

A stove foundry making plate from cold-blast charcoal iron, many years ago, found the plate to run hard, when the gates and sprues were remelted with pig, and threw them with all other small scrap into the dump. An attempt was made, after it had lain there for many years, to recover this high-priced iron from the dump, but it was found, after a considerable amount had been recovered and run into pig, that it was not worth the cost of recovering it. Other instances might be cited of the recovery of dump iron, but these are probably sufficient.

The experience of numerous foundrymen we have met show that it does not pay to recover iron from the dump, if it has lain there any length of time, no matter how great the quantity of iron in the dump.

The device patented for melting shot in iron pots, consisted of a pot or tube with one end closed and cast in a three-part flask, that a groove and number of small lugs might be cast on the open end for holding the cover in place. The cover was cast with a number of small notches for passing the lugs, and when dropped into place in the groove in the end of the pot, and slightly turned, was securely held in place by the lugs, and luted with clay or other material, to exclude air from the pot and its contents.

These tubes were made to hold from 50 to 100 pounds of shot, and when filled and luted were charged into the cupola with other iron, care being taken not to break them in charging.

These tubes or pots excluded the blast from the shot until the pot melted and its contents were heated almost to the melting point. But it was found that the pots did not improve the quality of iron melted from the shot to a sufficient extent to justify the expense of making, filling and luting them, and their use has long since been abandoned.

When melted in wooden boxes, the boxes are generally made of one-inch hemlock or other cheap boards, securely nailed to hold the small iron together, and from fifty to one hundred pounds of shot are placed in a box and the cover nailed on. These boxes are generally charged on top of the

pig, care taken not to break them, when charging scrap or other iron. The boxes do not burn in a cupola when charged with other stock, until they settle into the melting zone, where they are consumed, leaving the shot in a compact mass to be melted. This way of melting shot iron was supposed, for a number of years, to give excellent results in melting it, but this has been proved to be a fallacy, and the boxing of shot has generally been abandoned.

The enclosing of shot iron in pigs by pouring molten iron around it, is a very difficult and unsatisfactory operation.

When shot is placed in sand molds, many small particles are lost in the sand, and the sand in a short time becomes a scrap bed. When placed in an iron pig mold, in any quantities, the molten iron when poured upon the shot, does not penetrate the mass to any extent, and the only shot that adheres to the pig, when cold, is that on the surface, and much of this drops off in handling the pig. The only way to get this iron thoroughly enclosed in a pig is to place it in molten iron in the pig mold. This is a dangerous process, as damp, cold or rusted iron causes molten iron to explode, and it is almost impossible to keep this small iron entirely free from dampness and rust in a foundry. This way of preparing shot iron for melting is generally abandoned after a few trials.

From shot iron we may obtain when remelted three distinct grades of iron which for convenience in describing we shall classify as Nos. 1, 2 and 3 foundry pig, which are not to be confounded with foundry irons of these grades.

These three grades are made from exactly the same iron and may be cast in the same heat. But two of them are not produced by changes effected in the iron, in the cupola, nor by the size of shot or manner of cooling, but are produced by a change effected by oxidization, or rusting of the iron after it is cast.

In demonstrating the existence of these three grades of iron, numerous experiments were made in melting shot iron; to determine the cause of hard and uneven iron in castings when a soft iron had been placed in the cupola.

In making these experiments or tests, the shot was placed in closed wooden boxes and melted alone in a small cupola, that the results might not be changed by the mixing of iron from the shot with other iron that might have lodged in the cupola if melted at the end of a heat of other iron.

A few boxes of new clean shot from the tumbling barrels were first melted and run into pig. The pig when broken in various places showed a small crystal of an even size throughout the fracture, and in the different fractures. The iron filed and drilled freely in the pig, but was much harder than the iron from which the shot was made, and when run into a plate half an inch thick, which was done from the same ladle the pig was cast, was too hard to drill freely. This iron was afterwards found to be the softest iron that could be obtained from shot iron, and was designated No. 1 foundry pig.

A promiscuous lot of shot that had lain for some time, and was heavily coated with rust, was next boxed and melted in the same way. This produced a pig which, when broken in various places, showed a very uneven crystallization in the fracture. In some spots or places the iron was almost white, and in others showed a small open crystal. The half-inch plate cast from this iron showed an uneven fracture like the pig, and was too hard to be drilled in any part.

In this test a spotted, uneven iron was produced in the pig, and to determine the iron that caused the hard spots, the rusted pile of shot was carefully sorted, and all the very small or fine shot placed in boxes by themselves, and the large shot or pieces of iron placed in other boxes, and these two grades of shot melted in separate boxes.

The larger shot, among which were pieces weighing from one ounce to four or five pounds, when melted and run into pig showed a close mottled iron with an even crystal throughout the fracture.

The pig was too hard to drill freely, and the half-inch plate cast from this iron could not be touched with the drill; this iron was designated No. 2 foundry pig.

The small shot was next melted and poured into pig, which when broken showed a white iron in various parts of the pig, with no crystallization, and very hard and easily broken. This was designated No. 3 foundry pig.

The tests were made in a foundry making light castings and using soft iron, and all the shot was made from this grade of iron. The per cent. of iron lost in melting the different grades of shot described varied from 10 to 50 per cent. The lightest loss was in the new shot and the heaviest in the very small rusted shot.

These tests showed that rusted shot produced a hard iron, and the degree of hardness varied with the extent to which the shot was rusted. The small particles, which were almost entirely destroyed with rust, produced a harder iron than the larger shot, in which a considerable body of iron had not been affected by the rust. It also showed that the iron from heavily rusted shot would not unite with iron from larger shot to produce a homogeneous iron in a pig.

That iron from rusted shot is not softened by melting it with soft iron was shown later on in melting small rusted shot with a very soft No. 1 iron. In this test an equal weight of shot and pig were charged and run into pig, and also into light castings. The pig when broken showed a very uneven crystallization in the fracture. In some parts it was very open and soft; in others very close and hard; showing the two irons would not unite in a heavy casting to produce an even iron. In the thin castings, in which the iron had been suddenly cooled, the iron from the shot was white, and in some places had separated from the soft iron and sandwiched in between two layers of soft iron. In thicker castings it had separated and formed in small nodules.

These same phenomena have also been observed in other foundries when melting shot with other irons, and also when melting pig made from shot with other irons, showing conclusively that one of the causes of hard spots in castings is rusted shot iron, and that hard spots are not prevented by melting

shot at the end of a heat and running it into pig before melting with other iron.

Many careless molders never remove scrap from the top of molds before shaking out, and seldom throw out riddlings, until the sand heap becomes so filled with small scrap that it is no longer fit for molding. Scrap from top of molds and also riddlings are thrown in a corner or any out-of-the-way place, where they are permitted to remain for months. Gangways and also molding floors are frequently permitted to fill up with scrap and sand and only cleared and scrap recovered once in six months or a year. This scrap is heavily coated with rust and many of the small pieces are almost entirely destroyed by it.

To recover this iron, it is necessary to riddle all the refuse, or pass it through a separator, and in some cases to dry it before so treating. In few, if any cases, is the iron recovered of sufficient value to pay the wages of men for time employed in recovering it.

It is more economical to throw all this refuse in the dump, only recovering the larger pieces of iron as they may chance to be presented to view. When gangways are cleaned every day, a better grade of shot is recovered, but in this shot badly rusted scrap from the sand heap riddlings are found. These, when melted with new shot, produce hard spots; their hardening tendency can be removed to some extent, but not fully, by tumbling to remove the rust, but it will probably be found more profitable when only fine work is made, to provide a place for sand-heap riddlings and consign them to the dump.

We have not had sufficient experience in melting shot iron with a ferro-silicon iron, claimed to produce a soft casting with 90 per cent. of scrap, to accurately indicate results. This iron may restore to shot the properties removed by rusting, and enable the founder to profitably utilize all this class of iron, without risk of impairing the quality of his casting by hard spots.

In trying this, the shot and ferro-silicon iron should be drawn

from the cupola together into a large ladle to give the two grades of iron an opportunity to mix, and the iron should be well stirred before pouring. New shot from the dump and gangways mix with other iron when melted with it, and probably the best way to melt them is to distribute them through the heat, placing a small amount in the cupola with each charge of iron and in this way melting in each heat all the shot from the former heat. In describing this iron, to which the term *oxidised iron* is also applied, the term *rusted* has been used, for the reason that it is the term most commonly used in foundries, hence more readily understood by those most interested in foundry irons; and, also because the term oxidized is also applied to burned iron, and is therefore misleading.

BURNED IRON IN FOUNDRYING.

Burned cast iron presents the most varied as well as the most deceptive fracture of all the irons the founder has to deal with. The variations are due to the extent to which the iron is burned and also to the conditions under which it was burned. The deception is due to the changes effected in the crystallization of the iron by frequent or prolonged heating.

In a grate bar, we may find near the center a small crystal of a light bluish cast, and near the ends a large crystal with a dark blue cast. This is due to the center having been subjected to a greater heat than the ends. In heavy retorts, etc., we find a large crystal and open iron, presenting many of the characteristics of fracture in a very soft No. 1 pig iron. And in fact, in all burned iron, not burned in contact with fuel, we find in the fracture the characteristics of a soft iron.

The mistake commonly made by founders and melters is in judging this iron by the fracture, which in reality indicates nothing as to the quality of iron that may be melted from it. Grate bars are frequently broken and the center condemned and thrown in the dump, while the ends are melted, simply because the fracture near the end indicates a soft iron. Pieces of retorts and other burned castings are for the same reason melted that should be thrown away.

All burned iron should be judged by the external general appearance, and not by fracture. By general appearance is meant the entire casting should be considered and not certain parts of it, as is too frequently done.

In burning away the surface of a grate bar near the center, the ends are subject to a prolonged heat, of a degree lower than in the center, but sufficient to destroy the iron; although none of it may have been burned away near the ends and the external appearance gives no indication of the iron having been injured, the same rule applies to a greater or less extent to all castings, parts of which show indications of having been burned.

This principle is frequently better understood by junk dealers than founders, and in sorting scrap unprincipled dealers break off parts of castings showing external evidence of having been burned, throwing it in the burned iron pile, while that showing no evidence of being burned is thrown in the good scrap to be sold to founders, who judge scrap by fracture only. Retorts, pipes, salt kettles, etc., are broken into plates, slabs or pieces to destroy their identity, and thrown in a pile to rust before being placed with good scrap, a few pieces to the ton, to be sold as good scrap. This is one of the tricks of trade that founders have to look out for, to avoid unknowingly melting burned iron for their castings.

Burned cast iron in all cases, when melted in a cupola, produces a hard iron. The degree of hardness depends upon the extent to which the iron has been burned: from that only slightly burned, a hard gray or mottled iron may be obtained; from that burned to a greater extent, a white iron; and from that burned to a still greater extent, a very small per cent. of white iron, with an excessive amount of slag. These three grades may be found in a promiscuous lot or pile of burned iron, and when melted alone the product is generally a white iron, with a large amount of slag. The slag may boil in the cupola and stop melting, or may flow from the tap-hole with the iron, and in some cases cannot be distinguished from it until it has cooled to a considerable extent.

We have seen a large ladle full of this slag carried to the mold under the impression it was iron, and the mistake not discovered until an attempt was made to pour it, when it was found the slag could not be held back with a skimmer, and when dumped into the pig bed and cooled it was found there was only a few pounds of iron in the bottom of the ladle, all the remainder being slag, although it had all the appearance of molten iron as it flowed from the tap-hole and spout.

The melting of an entire heat of burned iron is generally a very unsatisfactory operation, and when once tried is seldom undertaken again by the same founder.

The nature or quality of an iron when burned is completely changed, and when melted with the same grade of iron from which it was made does not enter freely into combination with it. The change effected varies with the extent to which the iron is burned. That only slightly burned enters more freely into combination with a soft iron than that badly burned. When melting this iron with a soft iron, we may find it in castings combined only to a limited extent with the soft iron, and forming hard spots, or we may find it in thin plates, sandwiched in between two thin plates of soft iron; and in heavier castings, in nodules, separate and distinct from the soft iron.

More commonly, it enters into combination to some extent and forms hard spots, and hard spots in castings, especially in comparatively heavy castings, can more frequently be traced to burned iron than any other cause due to the iron.

To prevent hard spots from this cause, scrap should be carefully examined for burned iron before charging, and all suspicious-looking pieces thrown out, regardless of fracture indications. It will be found more economical to consign all such iron to the dump at once than to save it for future use.

WROUGHT-IRON SCRAP.

In a promiscuous lot of old scrap are to be found many pieces of wrought iron, such as bolts, nuts, stove rods, etc. This iron is totally different from cast iron, and when melted pro-

duces an iron that does not enter freely into combination with cast iron. This is more especially the case if the wrought iron has been burned or heavily coated with rust.

It is frequently claimed that these small pieces of wrought iron can have no injurious effect upon a large body of cast iron, but they certainly do. Their effect can frequently be noticed on iron in the molten state, as it flows over the spout and drops into a ladle.

The presence of such iron is indicated, to the close observer, only for an instant, as the iron flows through the spout, by a bright shower of very small sparks which disappear the instant the iron falls into the molten iron in the ladle.

In the ladle, it may enter into combination with the cast iron, if in very small quantities. If it does not so disappear, its presence is indicated in castings by hard spots, which may occur in flanges or parts of castings to be finished, and cause the casting to be condemned.

To prevent hard spots, all such iron should be broken from the scrap and thrown out, as should also all pieces of steel, when only a soft even iron is desired for the castings. Such iron has a higher market value than cast scrap, and it had better be sold than melted.

MELTING CAST IRON TURNINGS AND BORINGS.

Many tons of cast iron turnings, planings and borings are made by machine shops in finishing castings. The market value of this iron, when new and clean, is only about one-fourth that of the foundry iron from which it was made, and is not always salable even at this low price, in many sections of the country.

Founders having machine shops in connection with their foundries have reasoned that this iron came from soft castings and was therefore a soft iron, and available for melting and running into soft casting again. Many attempts have been made and plans devised for utilizing it in this way, all of which have proved failures to a greater or less extent, so far as obtaining a satisfactory soft casting from it was concerned.

Fine iron filings may be burned in a flame of a candle and nothing but a black oxide of iron left. When this iron is charged into a cupola in small quantities through a heat, it is probably all converted into an oxide, and consumed in the cupola; as no bad effect from it upon castings has been noticed when melted in this way, and probably no iron is obtained from it. The oxidizing action of the blast upon the small particles of this iron is so great that it can only be melted in a considerable body, and even then the iron obtained from it is white and only suitable for weights or work requiring such an iron. With a view of utilizing the iron for warming ladles and preparing it for future use, it has been charged upon the bed and poured into pigs after warming the ladles, but it was found the quality of iron was not improved by running it into pig, and melting of the heat was greatly retarded by placing it on the bed.

When charged at the end of a heat with a view of running it into pig, very little iron is obtained, and the greater part of the turnings, etc., are found in a more or less oxidized condition in the slag and cinder adhering to the lining, or in the dump.

To prevent oxidation of this iron in melting, it has been tightly rammed into cast iron pots, closed with a cast iron cover and luted to exclude the cupola blast and melted alone, and also with other iron. This plan proved a failure, as it was found the quality of iron obtained was not improved to a sufficient extent to justify the expense of the pots and labor in preparing them.

A number of plans have been devised to form this iron into a solid mass in pots, and also in molds without pots, by adding to it some material to make it stick together when rammed into a solid mass. For this purpose sal ammoniac water, molasses water, etc., have been used and the iron left for a few days after being rammed into a pig mold or other device, to rust into a solid mass before melting.

This plan worked very nicely so far as forming the iron into a solid mass was concerned, but it was found when melted that

the iron was not softened by preparing it in this way for melting.

Of all the plans devised for melting this iron in a cupola, probably the best one yet found is to place it in tight wooden boxes holding from 100 to 200 lbs. By this plan it is held together until it reaches the melting zone, when the boxes are consumed, leaving the iron in a compact mass to be melted. In this way an entire heat may be melted by placing the boxes in the cupola a little distance apart and putting coke between them to keep the cupola working open and free. By this means the oxidizing effect of the blast is reduced to a considerable extent, and a larger per cent. of iron obtained than when thrown in loose. But oxidation is not reduced to a sufficient extent to admit of a soft iron being obtained, and the iron melted is always white and hard. This fact should be remembered when melting this iron with other irons, as the resultant mixture is similar to that produced when melting hard pig or scrap with soft pig. If the cupola is tapped close and iron drawn into small ladles, soft iron may be poured from one ladle while hard iron may be poured from another.

The melting of this iron in boxes in a heat with other iron in the proportion of 5 to 10 per cent., has been known to give satisfactory results in heavy work, for which the iron was drawn in ladles holding a number of tons, and the iron given an opportunity to enter into combination with the soft iron in the ladle before pouring.

But, even when treated in this way, and poured into a heavy casting, it has in some instances been found to not thoroughly unite with other iron, and to produce hard spots in the casting, and also excessive shrinkage in parts of the casting, sometimes causing it to crack at a point least expected and at which the least strain on the casting should have taken place.

The uncertainty of results of melting this iron with other iron, either for light or heavy castings, is so great that I have never known of a founder continuing to melt it after he had experimented with it a sufficient length of time to learn of its

fallacies. The melting of this iron in ladles has also been tried, but results have generally been unsatisfactory, as only a limited amount of it can be melted in this way even when the iron is very hot, and when not very hot it may be carried into a casting unmelted with the iron, causing hard spots.

This may occur when the fine iron is thrown into the molten iron with the hand in small quantities. When placed in the molten iron from a shovel in quantities, it balls up and melts very slowly. When placed in the ladle before tapping, it forms into a solid mass in the bottom of the ladle and a layer of one inch in thickness may not be melted during an entire heat. It also causes small blow holes in castings when placed in molten iron.

In sections of the country where there is no market for this iron, it may be used for sidewalks, yard gangways, scrap-heap floors, etc. When used for this purpose a foundation of from 10 to 12 inches of ashes or cinder should be put down to prevent it being affected by frost. The iron, when clean and free from rust, should be thoroughly wet with a strong solution of sal ammoniac and placed upon the ash-bed three to four inches in thickness, even rammed down and left for a few days to dry before using. In a short time the iron will be found to have rusted into a solid plate of iron.

When the turnings are heavily coated with rust, they will not form a solid mass when treated in this way, and should be mixed with a thin cement, which will hold them in a solid mass and make an excellent walk or floor.

MELTING WROUGHT IRON AND STEEL TURNINGS AND BORINGS.

The melting of these turnings and borings in a cupola is more difficult and less profitable than the melting of cast iron ones. For when melted loose in small quantities, they almost or entirely burn up. When melted in pots or boxes they ball up into a solid mass which it is almost impossible to melt, and bung up a cupola very rapidly.

When melted in quantities in bulk they form into a solid

mass through which the blast does not penetrate except in spots, and in the only heat of them we ever melted in this way it was necessary to remove the lining before the cupola could again be placed in a proper condition for melting.

In a series of tests made in melting this scrap, the per cent. of metal obtained for that charged was very small and the quality of metal very inferior. In fact, it did not make a good solid sash weight, while it was entirely too hard and brittle for any other casting.

We should not advise the melting of this metal in a cupola, as from our experience we think it will be found more profitable to sell it, and in localities where there is no market for it to throw it in the dump, than to undertake to melt it in a cupola.

CHAPTER XI.

FLUXING OF IRON IN CUPOLAS.

FLUX is the term applied to a substance which imparts igneous fluidity to metals when in a molten state, and has the power to separate metals contained in metallic ores from the non-metallic substances with which they are found in combination; also to separate from metals when in a fluid state any impurities they may contain. Fluxes are also used for the purpose of making a fluid slag in furnaces to absorb the non-metallic residue from metals or ores and ash of the fuel, and removing them from the furnace to prevent clogging and to keep the furnace in good working order for a greater length of time. The materials used as fluxes for the various metals are numerous and varied in nature and composition, but we shall only consider those employed in the production of iron and the melting of iron for foundry work.

The substances employed for this purpose are numerous, but they consist chiefly of the carbonate of lime in its various forms, the principal one of which is limestone.

In the production of pig iron from iron ore in the blast furnace, limestone is used for the two-fold purpose of separating the iron from the ore, and for liquefying and absorbing the non-metallic residuum of the ore and ash of the fuel, and carrying them out of the furnace. For this purpose large quantities of limestone are put into the furnace with the fuel and ore. The stone melts and produces a fluid slag, which absorbs the non-metallic residuum of the ore and ash of the fuel in its descent to the bottom of the furnace. Thence it is drawn out at the slag hole, and carries with it all those non-metallic substances which tend to clog and choke up the furnace. By this process

of fluxing the furnace is kept in good smelting order for months, and even years. Were it not for the free use of limestone, the furnace would clog up in a few days.

The blast furnace is a cupola furnace, and is constructed upon the same general principle as the foundry cupola. Foundrymen long ago conceived the idea of using limestone as a cupola flux. In many foundries it is the practice to use a few shovelfuls or a few riddlefuls of finely broken limestone in the cupola on the last charge of iron, or distributed throughout the heat, a few handfuls to each charge of iron. The object in using limestone in this way is not to produce a slag to be drawn from the cupola, but to make a clean dump and a brittle slag or cinder in the cupola, that can be easily broken down and chipped from the lining when making up the cupola for a heat.

Limestone used in this way does not produce a sufficient quantity of slag to absorb the dirt from the iron and ash of the fuel and keep the cupola open and working free, but rather tends to cause bridging and reduce the melting capacity of the cupola.

The making of a brittle cinder in a cupola by the use of limestone depends to a great extent upon the quality of the stone. Some limestones have a great affinity for iron and combine with it freely when in a molten state, while others have but little affinity for iron and do not enter into combination with it at all. In the cinder piles about blast furnaces we find cinder almost as heavy and hard to break as iron, resisting the action of the atmosphere for years; while at others we find a brittle cinder that crumbles to pieces after a short exposure to the atmosphere, or even slacks down like quicklime when wet with water. In a cupola we may have a hard or brittle cinder produced by limestone. The results obtained from the use of limestone in small quantities in a cupola are so uncertain that we do not think they justify the foundryman in using it.

LIMESTONE IN LARGE QUANTITIES.

The tendency of slag or cinder in a cupola is to chill and

adhere to the lining just over the tuyeres and around the cupola at this point, and prevent the proper working of the furnace. So great is this tendency to bridge that a small cupola will not melt properly for more than two hours, and a large one for more than three hours. To overcome this tendency to clog and bridge, foundrymen in many cases have adopted the blast-furnace plan of using a large per cent. of limestone as a flux in their cupolas, and tapping slag.

When a large per cent. of limestone is charged with the iron in a cupola, it melts when it settles to the melting point and forms a fluid slag. This slag settles through the stock to the bottom, and in its descent melts and absorbs the ash of the fuel and dirt or sand from the iron and carries them to the bottom of the cupola, where the slag and dirt it contains may be drawn off and the cupola kept in good melting order and in blast for days at a time. The amount of limestone required per ton of iron to produce a fluid slag depends upon the quality of the stone and the condition of the iron to be melted. It is the custom in some foundries, where the sprews and gates amount to from thirty to forty per cent. of the heat, to melt them without milling to remove the sand, and to use enough limestone in the cupola to produce a sufficient quantity of slag to absorb and carry out of the cupola the sand adhering to them. In this case a larger per cent. of limestone is required than would be necessary if the sprews and gates were milled and only clean iron melted. Poor fuel also requires a greater amount of slag to absorb the ash than good fuel, and a lean limestone must be used in larger quantities than a stone rich in lime. The quantity required to produce a fluid slag, therefore, varies with the quality of the limestone and the conditions under which it is used, and amounts to from 25 to 100 pounds per ton of iron melted.

The weight of the slag drawn from a cupola when the sprews and gates are not milled, and the cupola is kept in blast for a number of hours, is about one-third greater than the weight of the limestone used. When the sprews and gates are milled,

the weight of the slag is about equal to the weight of the limestone. When the cupola is only run for a short time and slag only drawn during the latter part of the heat, the weight of the slag is less than the weight of the limestone.

The slag drawn from a cupola has been found, by chemical analysis, to contain from 4 to 7 per cent. of combined iron and numerous small particles of shot iron mechanically locked up in the slag. These cannot be recovered except at a greater cost than the value of the metal. In a number of tests made in the same cupola, we found the loss of iron to be from 3 to 4 per cent. greater when the cupola was slagged.

EFFECT OF FLUX UPON IRON.

Many of the limestones and other mineral substances employed as cupola fluxes contain more or less finely divided oxides, silicates, etc., in combination with earthy materials. The flux is often reduced in a cupola and its component parts separated, and in minute quantities they alloy with the iron and injure its quality. The conjoined effect upon iron of these diffused oxides, silicates, etc., liberated in a cupola from their native element in fluxes, is to prevent the metal running clean in the mold or making sharp, sound castings, and the tensile and transverse strengths are frequently impaired by them. When the oxides, silicates, etc., are not separated in the cupola from their native elements, they do not impair the quality of the metal, nor do they improve it. The tendency of the cupola furnace is to clog and bridge over the tuyeres, and concentrate the blast upon the iron through a small opening in the center and injure its quality. If by the free use of limestone we prevent bridging and keep the furnace working open and free, we avoid injuring the iron in melting by the concentration of a strong blast upon it. The effect, therefore, of limestone in a cupola is not to improve the quality of iron, but to prevent its deterioration in melting.

THE ACTION OF FLUXES ON LINING.

Limestone and other minerals employed as fluxes frequently contain impurities which enter into combination with the lining material of a furnace and render it fusible. This was illustrated at the foundry of John D. Johnson & Co., Hainesport, N. J., in 1893. The cupola front had been put in with new molding sand for a long time, and no flux used in the cupola. The sand made an excellent front that resisted the action of the heat and molten iron upon it. As the heats enlarged, it became necessary to use flux and tap slag to run off the heat. Oyster shells were used, and produced a slag that flowed freely and had no effect upon the sand in the front. When the supply of shells became exhausted, a limestone was used in place of them. Trouble then began with the front. It was melted by the flux into a thick, tough slag that settled down and closed up the tap hole, and iron could only be drawn by cutting away a large portion of the front to enlarge the tap hole. Mr. Johnson called at our office to learn what could be done to keep the tap hole open. We advised that the front material be changed and a mixture of fire-clay and sharp sand be used in place of molding sand. This was done, and there was no further trouble in keeping the tap-hole open and in good order to run off the heat. This serves to illustrate the effect of fluxes upon lining material. With no flux and with oyster shells the molding sand resisted the heat and pressure of molten iron and slag upon the front; but with limestone it melted into a thick, tough slag. This was due to some property in the limestone entering into combination with the sand and making it fusible. Had the cupola been lined with this molding sand, the entire lining would have been cut out in one heat, while it would have stood many heats with shells or no flux at all.

From the various qualities of cupola brick and lining material now in the market, a lining may be selected that will resist the action of almost any flux or slag, and foundrymen may select a flux to suit the lining or a lining to suit the flux, whichever they find to be the most profitable in their locality.

HOW TO SLAG A CUPOLA.

Foundrymen sometimes experience trouble in slagging their cupolas. This is largely due to a lack of knowledge in charging the limestone and drawing the slag, for any cupola can be slagged if properly worked. To draw slag from a cupola, a sufficient quantity of limestone or other slag-producing material must be charged in the cupola with the iron to make a fluid slag. The exact amount required can only be learned by experimenting with the fluxing material used, but it is generally from fifty to sixty pounds of good limestone per ton of iron, when the remelt is not milled. The limestone is generally charged on top of the iron and put in with each charge after the melter begins using it. No limestone is used with the iron on the bed or first few charges of iron. In small cupolas limestone is generally charged with the second or third charge of iron. In large cupolas, when the charges of iron are light, six or eight charges, or generally about one sixth of the heat, are charged without limestone. This is the way limestone is used when the cupola is run in the ordinary way for a few hours. When the cupola is run for some special work, the limestone is charged in a number of different ways.

The slag is drawn from the cupola through an opening known as the slag-hole. This opening is made through the casing and lining under the lower level of the tuyeres and at a point in the cupola where it will be out of the way in removing iron from the spout and convenient for removing the slag. The height the slag-hole is placed above the sand bottom depends upon how the iron is drawn from the cupola. When it is desired to hold iron in a cupola until a sufficient quantity is melted to fill a large ladle, the slag-hole is placed high, and when the iron is drawn as fast as melted the slag-hole is placed low. When the slag-hole is placed high, slag can only be drawn as the cupola fills up with iron and raises it to the slag-hole. When the iron is withdrawn from the cupola, the slag falls and the slag-hole is closed with a bod to prevent the escape of blast. When the iron is drawn from the cupola as fast as melted, the slag-hole is

placed low, and when opened it is permitted to remain open through the remainder of the heat. This is the best way of drawing slag from the cupola, for the flow is regulated by the amount of slag in the cupola, and if the hole is not made too large, there is no escape of blast.

The slag in the bottom of a cupola takes up impurities from the fuel and iron, and if permitted to remain in the cupola for too long a time, it may become so thick and mucky it will not flow from the slag hole. Or it may be filled with impurities, become over-heated, boil up and fill the tuyeres with slag; and when boiling, it will not flow from the cupola through a small slag hole. The time for drawing the slag from a cupola is therefore a matter of great importance. The slag hole is generally opened in from half an hour to an hour after the cupola begins to melt, and when placed low is permitted to remain open throughout the remainder of the heat. When placed so high that slag can only be drawn when the cupola fills up with molten iron, it should be opened as soon as the slag begins to rise and closed as soon as it falls below the opening.

DOES IT PAY TO SLAG A CUPOLA ?

Nothing is gained by slagging a cupola when the sprows and gates are milled and the heat can be melted successfully in the cupola without slagging; but a great saving in labor and wear and tear of machinery can be effected in many foundries by melting the sprows and gates with the sand on, and slagging to carry the sand out and keep the cupola working free. A cupola can not be made to melt iron faster by slagging, but it can be kept in blast and in good melting condition for a greater length of time and a much larger amount of iron melted by slagging. Foundrymen who find their cupolas temporarily too small to melt the quantity of iron required for their work, can overcome the difficulty by slagging the cupola and keeping it in blast for a greater length of time.

In endeavoring to make an estimate of the cost of slagging a cupola, we found that the cost of limestone in different localities

varied from 50 cents to \$3 per ton. The amount used varied from 25 to 100 pounds per ton of iron melted. The amount of slag drawn varied from 25 to 100 pounds per ton of iron. The iron combined with the slag varied from 4 to 7 per cent. With these wide differences in the cost and quantity of limestone used, and the difference in the quantity of slag drawn and per cent. of iron it contained, we found it impossible to make an estimate that would be of any practical value to foundrymen. Such an estimate must be made at each foundry to be of value.

SHELLS.

Oyster, clam and other shells are largely composed of lime, and are frequently used as a flux in place of limestone in localities where they can be procured at a less cost than limestone. The shells are charged in the same way as limestone and in about the same proportion to the iron. They may be used in place of limestone either in large or small quantities, and have about the same effect upon the iron and cupola as limestone. When used in large quantities, they produce a fluid slag that keeps the cupola working free and flows freely from the slag-hole, carrying with it the refuse of melting that clogs the cupola. When the heat first strikes shells in a cupola, they produce a crackling noise and flakes of shell may be seen to pass up the stack, and the foundry roof, when flat, is often covered with flakes of shell after a heat, when they are used in large quantities. The crackling is due to the destruction of the hard inner surface of the shell; the flakes thrown from the cupola are entirely of this surface, and the loss of shell is not so great as it would appear to be at first sight. The remainder of the shell melts and forms a fluid slag that absorbs the refuse of melting, becomes thick and helps to clog up a cupola when the shells are used in small quantities, or assists in keeping it open when used in large quantities.

MARBLE SPALLS.

Marble is another of the carbonates of lime, and the spalls or

chippings from marble quarries or works are quite extensively used in some localities as a cupola flux. Their action in a cupola and their effect upon iron is very similar to that of limestone, and they are used in the same way and in about the same proportions. There are a number of other substances, such as fluor-spar, feld-spar, quartz-rock and a number of chemical compounds that are used as cupola fluxes.

In 1873, when engaged in the manufacture of malleable iron, we began experimenting with mineral and chemical materials with the view of making a cheap malleable iron, and changing the nature of iron in a cupola furnace so that it might be annealed at a less cost, and produce stronger iron. In this we succeeded to some extent, and then drifted off into improving the quality of iron in a cupola for grey iron castings; this we have followed for nearly twenty years. During this time we have melted iron in foundries all over the greater part of the United States and Canada, and have constructed and worked a number of experimental cupolas of our own, to learn the effect of different mineral and chemical substances upon iron and cupola linings. In these investigations we have used all the mineral and chemical fluxes known to metallurgical science, and observed their effect upon the various grades of iron employed for foundry work.

In these experiments it was found that iron can be improved or injured when melted in a cupola furnace, and is often ruined as a foundry iron by improper melting and fluxing. The point at which iron is melted in a cupola has a great deal to do with its quality. Iron melted too high in a cupola is burned and hardened; melted too low, it runs dirty in a mold; melted with too strong a blast, it is hardened. Iron melted dull does not make a sound casting. Iron melted with poor coal or coke is injured by the impurities in the fuel. Iron melted with oyster shells, limestone and other mineral fluxes may take up oxides, sulphides, phosphides, silicates and other impurities contained in the flux and be ruined by them for foundry work.

The per cent. of iron lost in melting is increased by improper

melting and fluxing, and may be double or treble what it should be. We have made a great many experiments to ascertain the effect of silicon on iron, and have found that silicon enters freely into combination with cast iron and has a softening effect upon it. Iron as hard as tempered steel may be made as soft a lead by combining it with silicon. But silicon is an impurity having a deleterious effect upon iron. An excess of it destroys cohesive force and crystallization, and reduces transverse and tensile strength. So great is the destruction of cohesive force in cast iron by silicon that the strongest iron may be reduced to a powder when combined with an excess of silicon. Silicon in any proportion is a detriment to cast iron, as an iron. The nature and form of crystallization of a pure cast iron is changed by sudden cooling in a mold, and a soft iron in the pig may become a hard iron in a casting. This chilling property in cast iron is destroyed by silicon, and an iron high in it is not hardened when run into a sand mold or upon an iron chill. The destruction of the chilling tendency in cast iron is very desirable in the manufacture of light castings, and for this reason silicon irons are largely used in foundries making this class of work.

The per cent. of silicon an iron may contain and yet retain sufficient cohesive force for the work, depends upon the amount of other impurities in the iron and the work the iron is employed to make. For heavy work, requiring great strength, it should contain none at all. For light machinery it may contain from one-half to one per cent.; and for stove plate, light bench work, etc., it may contain from two to three per cent. These amounts are sufficient to reduce the chilling tendency of the iron, without impairing its strength to any great extent in these classes of work. But a larger amount destroys the strength of the iron and also injures its flowing property in a mold.

At the present time there is a large amount of high silicon cheap Southern iron being used in stove foundries for the purpose of making a cheap mixture and a soft casting. At one of

these foundries we recently visited, the foreman informed us that they were using a mixture that cost \$14 per ton, and said their breakage in the tumbling barrels and mounting shop was very large, and he never made a shipment to their warehouse in New York, a distance of 25 miles, but a lot of stoves were broken in transit and sent back to be remounted and repaired.

At another stove foundry in Troy, N. Y., they informed us they were using a mixture of Pennsylvania irons that cost them \$20 per ton. They had scarcely any breakage at their works, and shipped their lightest stoves and plate to their warehouse in Chicago without boxing or crating, and never had any breakage in transit or in handling. They had found by experience that a mixture of Pennsylvania irons at a cost of \$20 per ton was cheaper in the long run than a mixture of cheap Southern irons at \$14 per ton.

In a number of other foundries we visited, they all complained of heavy breakage when using high silicon irons as softeners. Another matter to be considered in using these high silicon irons for stove plate, is, how long will a stove last, made of such weak iron, and can a reputation for good work be maintained by foundries using them? A stove made of this kind of iron will certainly not last so long as one made of good iron.

Carbon has the same effect upon cast iron as silicon, in softening and reducing the chilling tendency. The hardest of cast iron can be made the softest by the addition of carbon, without destroying its cohesive force and rendering it brittle or rotten, and carbon can be added to iron in a cupola as readily as silicon. Before the high silicon Southern irons were put upon the Northern market, highly carbonized irons were used as softeners for stove plate and other light work, and a far better grade of castings was made then than now is made from the silicon irons.

It is difficult to remove silicon from iron when melted in a cupola, but free carbon is readily removed by the oxidizing flame produced by a strong and large volume of blast; and a soft iron may be hardened in melting to such an extent as to

make it unfit for the work. This can be prevented to some extent by using a mild blast and melting the iron low in the cupola, and it can also be prevented by the use of chemicals to produce a carbonizing flame.

We have spent a great deal of time and money in experimenting on the production of such a flame in a cupola as would not only prevent the deterioration of iron in melting, but would improve its quality, and at the present time are engaged in the manufacture of a chemical compound for this purpose.

FLUOR SPAR.

Fluor spar is extensively used as a cupola flux, in sections of the country where it is found native and can be procured at a moderate cost, and it has also been used to a considerable extent in other sections of the country, but the expense of transporting this heavy material has greatly retarded its use as a flux at any great distance from the mines. Fluor spar when used in sufficient quantities in a cupola, produces a very fluid slag that absorbs and liquefies the non-metallic residue of melting with which it comes in contact, keeps the cupola open and working freely, and causes it to dump clean. But it also fluxes the cupola lining, causing it to burn out in a very short time, and for this reason it can only be used in large quantities with certain grades of lining material that are only affected to a very limited extent by it. This quality of lining material can generally be procured in the vicinity of the mine, but it cannot always be had at a moderate cost in other parts of the country, and for this reason it is frequently used with limestone to increase the fluxing properties of the limestone and reduce the injurious effect of the spar upon the cupola lining. When used in this way, fluor spar greatly increases the efficiency of a poor limestone, and often enables a founder to use a cheap limestone that could not be employed alone as a flux, while the limestone reduces the injurious effect of the spar upon the lining, and the two combined make an excellent flux for tapping slag in long heats.

We have used fluor spar in a number of cupolas and with a great many different brands of iron. We never found it to harden or soften any of these irons to a noticeable extent, but it improved the melting very materially in a number of cases where the cupola was run beyond its melting capacity, melted slow in the latter part of the heat, and could not be dumped without a great deal of labor.

CLEANING IRON BY BOILING.

Before the use of fluxes in cupolas was so well understood as at the present time, it was a common practice in many foundries to cleanse iron of impurities in a ladle by agitating or boiling the molten metal. This caused a large amount of dross to collect on the surface, from which it was skimmed off and the iron was considered to be purer after the boiling. A favorite way of agitating iron in a ladle was to place a raw potato or apple on the end of a tap bar and hold it in the molten metal, near the bottom of the ladle, for a short time. The potato or apple contained a sufficient amount of moisture to agitate or boil the metal gently without exploding it, and the metal was said to be greatly benefited by this gentle boiling; but practice has demonstrated that nothing is gained by boiling iron in a ladle, and it has long been discontinued in this country.

A ball of damp clay placed upon the end of a tap bar was also used for boiling iron in a ladle, but this was not considered so good or so safe as an apple or potato, for if the clay chanced to be too damp, it caused the iron to boil violently and sometimes to explode.

Another favorite way of cleansing and mixing irons years ago was to pole the molten iron. This was done with a pole two or three inches in diameter, of green hickory or other hard wood. The pole was thrust into the molten metal in a ladle or reverberatory furnace, and the metal stirred with it. The effect of the green wood thrust into the metal was to cause it to boil around the pole, and as the pole was moved through the metal

all parts of it were agitated, and a better mixture of the different grades of iron melted was effected and a more homogeneous casting produced. The poling of iron was a common practice in many foundries twenty-five years ago, but we have not seen it done in a ladle for many years, and we believe the practice has been entirely discontinued with cupola-melted iron; but poling is still practiced in many foundries in the mixing of iron in reverberatory furnaces for rolls and other castings requiring a very strong homogeneous iron.

CHAPTER XII.

WHAT A CUPOLA WILL MELT.

THE cupola furnace was originally designed for melting cast iron for foundry castings, and at the present time is principally employed for that purpose, but it is now also used in the melting of almost all of the various grades of manufactured iron and steel, and many other metals.

It is extensively employed in the melting of pig iron, in the manufacture of Bessemer steel, and in the melting of iron for castings to be converted into steel and malleable castings after they are cast. It is also used in melting steel for steel castings, but as it makes an uncertain grade of steel it is only employed for the more common kind of castings.

It is also employed in melting tin plate scrap, sheet iron, wrought iron and steel wire, gas pipe, bar iron, horse shoes and all the various grades of malleable wrought and steel scrap, found in a promiscuous pile of light scrap and used in the manufacture of sash, elevator and other weights, and melts them readily, producing a very hot fluid metal, and when properly managed is the very best furnace for this purpose.

It is to some extent used in the smelting of copper ores and the melting of copper, in the manufacture of brass, and also in the melting of brass for large castings; but in melting brass, the alloy is oxidized to so great an extent that an inferior quality of brass is produced to that obtained from crucibles.

Lead is frequently melted in cupolas. It melts more slowly than would naturally be expected, and it is very difficult to retain it in a cupola in the molten state, as it is almost impossible to put in a front through which it will not leak, and the ladle is generally heated and the tap hole left open.

The quantity of cast iron that can be melted in a cupola per

hour depends upon the diameter and height of cupola, and at the present time varies from one hundred pounds to twenty tons. The number of hours a cupola will melt iron freely when properly managed, is only limited by the length of time the lining will last. Cupolas have been run continuously from one o'clock Monday morning until twelve o'clock Saturday noon, melting fourteen tons per hour.

The size and weight of a piece of cast-iron that can be melted in a cupola at one heat, depends upon the size of the cupola.

As a rule, any piece of iron that can be properly charged in a cupola can be melted. In steel works cupolas, ingot moulds weighing five tons are melted with ease in the regular charges of the cupola.

At the foundry of the Pratt & Whitney Co., Hartford, Conn., a large charging opening is placed in the cupola for the purpose of charging large pieces of iron to be melted, and almost any piece can be melted in one heat that can be placed in the cupola.

At the foundry of the Lobdell Car Wheel Co., Wilmington, Del., an oblong cupola with charging door placed at the ends was constructed shortly after the War of the Rebellion to melt cannon and other heavy government scrap, and large cannon weighing many tons were melted in this cupola without previously breaking them up.

MELTING LARGE PIECES OF IRON.

In jobbing and machine foundries, bad castings are sometimes made or pieces purchased in scrap that are considered too large to melt in the cupola and cannot be broken with the appliances at hand for breaking. Such pieces are frequently permitted to lie in the foundry yards for years, and if they chance to be bad castings, may often be buried, as we have frequently seen them, by foreman or molders to get them out of sight. Such pieces are frequently permitted to lie in the yard through lack of knowledge in melting or of what consti-

tutes a large piece to melt in a cupola; and a few words on this subject may be of value.

What constitutes a large piece of iron to be melted in a cupola, depends upon the size of cupola.

A piece weighing a few hundred weight may be a large piece for one cupola, while a piece weighing several tons may not be a large piece for another. A good way to decide this is by the weight of iron placed upon the bed when charging.

A piece of iron weighing no more than the weight of small iron placed on the bed or charge is not a large piece to melt, and may be charged and melted the same as small iron in regular heats. Such pieces should be put in after the first or second charge, that they may have time to heat before settling into the melting zone. No extra fuel should be used in melting such pieces, for extra fuel places the pieces too high in the cupola, makes the cupola melt slow, and may be the cause of failure to melt the piece. Large pieces weighing three or four times the weight of a charge cannot be melted in this way, for the piece may not all be melted, before the molten iron comes down too dull for pouring, and such pieces should be melted alone.

When melting such pieces an extra bed of about six inches should be put in for the purpose of heating the iron preparatory to melting, before settling into the melting zone, and fuel should be placed around the piece to concentrate the heat upon it.

In this way iron may be melted sufficiently hot for casting, but if considerable fuel cannot be placed around the piece, the iron will come dull after an amount equal to two or three charges has been melted.

When this occurs and the iron begins to melt slow, all the melted iron should be drawn off and the bottom at once dropped to prevent the unmelted piece being lodged in the cupola, and the piece again charged in the same way for another heat. In this way any piece of iron that can be placed in a cupola may be melted.

MELTING TIN PLATE SCRAP IN A CUPOLA.

Tin plate scrap is melted in the ordinary foundry cupola the same as cast iron scrap, but more fuel is required to melt it. The best results are obtained with 1 pound of coke to from 3 to 4 pounds of scrap and a mild or light blast. Various ways of preparing the scrap for charging, such as hammering or pressing it into ingots and forming it into compact balls, have been tried; but as good results are obtained by charging it in bulk, and it is generally placed in the cupola in this way. The charges are made of about the same weight as charges of iron in a cupola of similar size, but more fuel is added. The scrap when first put in the cupola is very bulky and takes up a good deal of room, but when heated it settles down into a compact mass, and takes up very little more space than a charge of cast iron scrap. Tin plate scrap settles rapidly, but melts slower than cast iron scrap or pig.

Numerous attempts have been made to recover the tin deposited upon the iron by heating the scrap in various ways to a temperature at which tin melts, but the coating of tin is so light it will not flow from the iron. All such attempts to recover it have proved failures. The iron, or rather steel, which is coated with tin is a very soft and tough material, but when melted the tin alloys with it, and the metal produced is very hard and brittle. The molten metal from this scrap has very little life, chills rapidly in the spout, ladles or molds, must be at a white heat when drawn from the cupola, and must be poured as quickly as possible. When not melted extremely hot the metal expands or swells in cooling to so great an extent as to tear a sand mold to pieces or break an iron mold where it cannot escape. When the metal is melted very hot this expansion does not take place to so great an extent, and a sand or iron mold may be used for any work into which it is to be cast.

The molten metal is more susceptible to the effect of moisture than iron, and is instantly thrown out of a mold when sand is worked too wet and cannot be made to lie in it. The

sand must, therefore, be worked as dry as possible. The metal is very hard and brittle, and only fit for sash and other weights, and even these when light and long must be handled with care to avoid breaking. The weights when rough cannot be chipped or filed smooth, and sash weights made of this metal are generally sold at a less price than iron weights; for when rough they wear out very quickly the wooden box in which they are hung, and builders dislike to use them. A foundryman who recently had a contract from the Government for a number of weights of several tons each, to be used for holding buoys in the ocean, made them from tin plate scrap. When cast they were so rough that he remarked it was a good thing they were to be sunk in the mud under the ocean, for they were not fit to be seen.

In a number of experiments we made in melting this scrap, we found we could produce a gray metal from it about as hard as No. 3 pig iron, by melting it with a large per cent. of fuel and a very light blast. But the metal was very rotten and had little if any more strength than when white. We tried a number of experiments to increase its strength, but in none of them did we succeed to any extent. Melting it very hot and running it into pigs and remelting the pig improved the strength in some degree; but this was expensive, and the results did not justify the expense. We also made a number of tests to learn the amount of metal lost in melting this scrap, and found with a light or proper amount of blast to do good melting there was practically no loss. With a strong blast the loss was heavier, and in one heat, with a very heavy blast, we lost 10 per cent. of the metal charged. The metal from this heat was a little stronger and also a little harder, which was probably due to oxidation of the tin from the iron by the strong blast before melting. In melting old roofing tin, rusted scrap and old cans, the loss in melting varied from 10 to 25 per cent., which was probably due to rust, paint and solder used in putting the work together.

Tin acts as a flux when melted with iron, and renders it more

fusible. Scrap from which the tin has been removed by acids to recover the tin or by the process employed in the manufacture of chloride of tin, is more difficult to melt in a cupola than when covered with tin, and more fuel and time are required to melt it, but a better grade of iron is produced from it. Scrap of this sort should be melted soon after the tin is removed from it, for it rusts very quickly, and when rusted to any extent produces nothing but slag when melted.

Scrap sheet iron is more difficult to melt than tinned scrap and is seldom melted in a cupola, for better prices are paid for it by rolling mills than foundrymen can afford to offer.

Galvanized sheet-iron scrap cannot be melted at all in a cupola in large quantities, for the zinc used in galvanizing it, acting like the zinc solution used in the Babcock fire extinguishers, and reduces the heat in the cupola to a marked degree. When melting tinned scrap any galvanized scrap that has been mixed with it must be carefully picked out, for even in small quantities it lowers the heat in a cupola to such an extent that the metal from the tinned scrap cannot be used, and must be poured into the pig bed if it runs from the cupola at all. There are a number of ways of doctoring the metal from tin-plate scrap when it melts or flows badly, by the use of gas and oil, retort carbon, etc., but they do not improve the quality of the metal to any extent, and it is very doubtful if they increase its melting and flowing properties.

A cupola of any suitable size can be employed for melting tin-plate scrap and an entire heat of the scrap may be melted alone, or it may be mixed with cast-iron scrap or pig, and melted, or again, it may be melted alone directly after a heat of iron. It is a common practice in many small foundries to melt this scrap in the cupola for sash and other weights directly after melting a heat of iron for soft castings. An extra heavy charge of fuel is placed upon the last charge of iron to check the melting for a few minutes by preventing the scrap settling into the melting zone, and the soft iron is all melted and drawn off before the scrap begins to come down. In melting long

heats of this scrap it is necessary to flux the cupola with limestone or shells in sufficient quantities to produce a fluid slag. The flux should be put in on the first charge of scrap in very small cupolas and on the second or third charge in large cupolas, and on each charge throughout the heat afterward. The slag hole should be placed at the lowest point consistent with the amount of molten metal to be collected in the cupola at one time, and opened as soon as the first charge of scrap, upon which flux is placed, has melted. The slag hole may be opened and closed from time to time, but it is better not to make the hole too large, and leave it open throughout the heat. The flow of slag then regulates itself, and there is no danger of it running into the tuyeres. In melting a few hundredweight of this scrap in a cupola, after melting a small heat of iron, it is not necessary to charge flux in sufficient quantities to produce a fluid slag to be tapped, unless the cupola is very small and shows signs of bunging up. In this case flux must be charged with the iron, and slag tapped early in the heat, to keep the cupola in condition to melt the scrap after the iron is melted.

When constructing a cupola expressly for melting tin-plate scrap the charging door or opening should be placed about 6 inches above the scaffold floor, so that the scrap may be dumped in from a barrow and save handling it a second time with forks. The charging door should be much larger than in a cupola of the same diameter for melting iron, and should be not less than 3 or 4 feet square in any case, and for cupolas of very large inside diameter the opening should be equal to one-half or three-fifths the diameter of the shell, and 4 or 5 feet high. The height of the door above the bottom depends upon the diameter of the cupola. In large cupolas it should be placed 18 or 20 feet above the bottom and in smaller cupolas as high as possible without danger of the stock hanging up in the cupola before settling into the melting zone. The lining material must be carefully selected, for a poor fire brick will not last at the melting zone through one long heat; in fact, none of the fire brick lasts very long at this point, and it is gen-

erally necessary to put in a few new ones after each heat. High silicon brick is said to last better than any other brick, but some of the native stone linings which we have described last longer in melting this scrap than any of the fire brick, and they are generally used for lining cupolas for this work. The cost of melting tin-plate scrap in a cupola is from \$1 to \$2 per ton more than the cost of melting iron. The amount of profit in melting this scrap for weights, &c., depends, like all other foundry business, upon the location and size of the plant and the management of the business; but at the present time, even under favorable circumstances, the profits are small.

CHAPTER XIII.

ART IN MELTING.

THE melting of iron in a cupola is an art that is by many foundrymen and foundry foremen but little understood, and they never begin the melting of a heat without a dread that something will happen to prevent the iron being hot enough for the work, or that they may not be able to melt the entire heat. In many foundries it is almost an every-day occurrence to have something happen in or about the cupola to prevent good melting. The sand bottom cuts through, the front blows out, the tap hole cannot be opened without a heavy bar and sledge, slag flows from the tap hole with the iron and bungs up the spout and ladles, iron and slag get into the tuyeres, daubing falls off the lining and bungs up or bridges the cupola, stock lodges upon the lining in settling, and only part of the heat can be melted. Iron melts so fast in one part of the heat that it cannot be taken care of; in another part it melts so slowly that a ladle cannot be filled before the iron is too dull for the work; or, iron is not melted of an even temperature throughout a heat, and has to be watched in order to get hot iron to pour light work; the first iron is dull, or the last is dull, or the whole heat is dull. Some of these troubles to a greater or less extent occur almost daily, and it is a rare occurrence in a great many foundries that a perfectly satisfactory heat is melted. In foundries in which these difficulties occur, the foundryman or his foreman, or both, do not understand melting, the cupola is in charge of an old professional melter, who always ran it in this way, or a foundry laborer or helper has been selected for a melter and given a few instructions by some one who has seen a cupola prepared for a heat, or perhaps has melted a few heats. He is instructed until he melts a

heat successfully, and then he "knows it all," and is left to himself, and perhaps he knows as much as his instructor. If he is a practical man, he learns the cause of all the troubles in melting and in time becomes a fair melter; but at what an expense to his employer!

If he is not a practical man, he bungles along from day to day until he gets disgusted with his job and quits, or is discharged, and another man of the same kind is tried, with about the same result, for there is no one about the foundry who understands the art of managing a cupola to instruct him, and he must learn it himself, or as a melter be a failure. The foundryman or foreman of a foundry in which this kind of melting is done, will tell you a cupola is a very hard thing to manage, and it cannot be made to melt evenly throughout a heat or the *same every heat*. If this were really the case foundries making very light work, requiring hot fluid iron, would lose half their castings every heat or be compelled to pour large quantities of iron into the pig bed, and wait for hot iron. But this is not the case in stove, bench and other foundries making very light castings. Heats of many tons are melted every day, and as many pounds of iron are melted in one minute as in another from the beginning to the end of a heat, and there is not a variation of fifty degrees in the temperature of the iron from the first to the last tap.

There is no chance work in nature, and there is no chance work in art when the scientific principles are understood and applied to practice, and there is no chance work in melting iron in a cupola when the cupola is scientifically managed, and there is no furnace used for melting iron more easily managed than the cupola furnace; but it is necessary to understand its construction and mode of operation to do good melting.

In the first place, the cupola must be properly constructed and of a size suitable for the amount of iron to be melted, and the time in which this melting is to be done. For fast melting, a cupola of large diameter is required, and for slow melting one of small diameter. There are those in use at the present

time in which sixty tons of iron are melted in four hours, and those in which one ton of iron is melted in four hours and a half, and each of these cupolas melts iron as fast as it can be taken care of after it is melted. The large cupola would be useless in one foundry, and the small one in the other. So it follows that a cupola must be so constructed as to be suitable for the melting it is desired to do.

To melt iron hot and of an even temperature, the tuyeres must be placed low, made of a size to admit the blast freely to the cupola, and arranged to distribute the blast evenly to the fuel, and the latter must be of a proper volume for the size of cupola. To utilize the greatest possible amount of heat from the fuel, the charging door should be placed high and the cupola kept filled to the door until the heat is all in. When preparing a cupola for a heat, it must be properly chipped out and the lining given the best possible shape for melting, by the application of daubing. The daubing material must be of an adhesive and refractory nature, and not put on so thick that it will fall off when dried or heated. The bottom door must be put up and supported by a sufficient number of props to make it rest perfectly solid against the bottom plate. The bottom sand must be of a quality that will not burn or be cut up by the molten iron, and it must be of a temper that will neither wash nor cause the iron to boil. It must be carefully packed around the edges and rammed evenly, and no harder than the sand for a mould, and given a proper pitch to cause the iron to flow to the tap hole as fast as melted. A front and spout lining material must be selected or prepared that will not cut or melt. And the front must be put in solid with a proper sized tap hole, and the spout given the right shape and pitch. The cupola having been thus prepared, it is ready for melting. Shavings and wood are put in for lighting the melting fuel or bed, and a sufficient quantity of coal or coke is put in to fill the cupola to the top of the melting zone after it has settled. As soon as this fuel is well on fire, and the heavy smoke is burned off so that the top of the bed can be seen, it is leveled up with a few

shovelfuls of fuel, and charges of iron and fuel are put in until the cupola is filled to the door. The weight of the bed fuel, and charges of iron and fuel, must be learned for each cupola, for scarcely any two are charged exactly alike.

It will thus be seen that the melting of iron in a cupola is very simple. But all these things and many more must be learned and practiced to make it so, and they cannot be learned in one or in a dozen heats. Slag and cinder adhere to the lining at one point to-day and at another to-morrow, and the chipping out must be different. The lining is burned away more at one point to-day than it was yesterday. A new lining requires a different shaping than an old one, as lining burns out and the diameter of the cupola increases. More fuel is required for a bed, and the weight of charges of fuel and iron must be increased. All bricks are not suitable for a cupola lining, and a good brick may be laid up in such a way that a lining will not last half so long as it would do if properly put in. All daubing material is not suitable for repairing the lining of a cupola, and the best daubing is worthless when not properly applied. Bottom sand when used over and over again becomes worthless, and all sands are not suitable for a bottom. The front may be put in with material that melts, and the tap hole cannot be kept open and free of slag; or the front made of a shape that iron chills in the tap hole between taps. The spout lining material may not be suitable, and may melt and bung up the spout with slag, or the lining may be made of a shape that two or three ladles are required to catch the many streams that fall from it at the same time.

To learn to manage a cupola perfectly, a close study of all the materials used in melting and their application to melting are necessary, and months of careful observation are required to learn them, but by an intelligent man they can be learned. A molder, when serving his time as an apprentice, is seldom given an opportunity to learn melting, and when he becomes foreman of a foundry knows nothing whatever about the management of a cupola and is completely at the mercy of the

melter. The time has passed in many localities when the entire force employed in a foundry was subject to the whims of a melter and compelled to take a day off whenever he did not see fit to work, and a foreman who does not fully understand the management of cupolas is no longer considered a competent man to have charge of a foundry. It should be the aim of every molder who aspires to be a foreman or foundryman to learn melting, and when he takes charge of a foundry he should at once learn all the peculiarities of the cupolas of that foundry, and be able to run off a heat as well as the melter, or instruct the melter how to do it. In conversation with foremen, we have frequently remarked to them that the foreman of a foundry should be the melter, and many of them have replied that they would give up the foremanship before they would do the melting. To be a melter does not imply that the melter should perform the labor requisite to melting, for a melter may direct the melting of a heat without ever touching the iron to be melted or any of the material required to melt it. By going inside for a few minutes and giving directions how it must be done, any intelligent man can be employed to do the work, and he can be instructed from the charging door how to pick out and daub a cupola or repair a lining. He can be shown how to put up the doors and support them in place; how to prepare daubing, front and spout material, select and temper bottom sand, and instructed from the charging door and front, how to put in a bottom front and spout lining; how to light up and burn the bed, and given a slate of charges and directions for putting them in the cupola. After he has been directed by a competent melter in this way for a few heats, it is only necessary for the melter or instructor to inspect his work from time to time, to see that it is properly done and prevent the lining getting out of shape or other things occurring, in which a new melter cannot be instructed in a few days; and his work should be inspected to prevent him getting into a rut, as melters so frequently do when left to themselves.

TAKING OFF THE BLAST DURING A HEAT.

The length of time the blast can be taken off a cupola after it has been in blast long enough to melt iron, and put on again and good melting done, depends upon the condition of the stock in the cupola at the time it has been stopped.

The blast may be taken off a cupola that has only been in blast for a short time, is in good melting condition and filled with stock, for many hours if the melted iron and slag are all drawn off and the tuyeres carefully closed to exclude the air and prevent melting and chilling after the blast has been stopped. We have known a cupola in this condition in case of a break-down in the blowing machinery to be held from four o'clock in the afternoon until eight o'clock the following morning, and good melting done when the blast was again put on.

In this case, the tuyeres were packed with new molding sand rammed in solid to completely exclude the air, and the molten iron all drawn off, after the tuyeres had been closed for a short time and the tap hole closed with a bod. Before putting on the blast in the morning, the tuyeres were permitted to remain open for a short time, to allow any gas that might have collected in the cupola during the stoppage to escape and avoid an explosion, which might have occurred had a large volume of blast been forced into the cupola when filled with gas.

Cupolas that have been in blast for some time and from which the blast is removed toward the end of the heat when the cupola is comparatively empty, or in bad shape for melting, cannot be held for any great length of time, even if the tuyeres are at once closed and every precaution taken to prevent chilling and clogging. This is due to the gradual settling of a semi-fluid slag and cinder above the tuyeres, and the closing up of small openings in it through which the blast was distributed to the stock; and in case of accident to the blower it is better to dump the cupola at once than to attempt to hold it for any length of time.

Cupolas, in which all the iron charged has been melted and drawn off, may be held over night, if the cupola has been

properly fluxed, the slag drawn off, and a fresh charge of coke put in, with a liberal charge of limestone on top of it to liquefy any slag that may over night have chilled in the cupola. Small cupolas are frequently managed in this way; the tuyeres are closed and the tap hole permitted to remain open to admit sufficient air to ignite the fresh coke.

In the morning after the cupola has been filled with stock and the blast put on, the limestone on the bed is the first to melt, and if in sufficient quantity makes a fluid slag that settles to the bottom, freeing the cupola of any clogging that may have taken place during the stoppage.

BANKING A CUPOLA.

Since writing the foregoing we have received the following practical illustration of keeping a cupola in good condition for melting for many hours after it had been charged and the blast put on, from Mr. Knœppel, Foundry Superintendent, Buffalo Forge Co., Buffalo, N. Y. In this case melting had not begun before the pulley broke and the blast was taken off, but the same results would have been obtained from banking the cupola in this way if melting had begun and the cupola been in blast for a short time. Mr. Knœppel writes as follows:

“Banking a cupola is something that does not come in the usual course of foundry practice, but there are times when the knowledge of how it is to be done would be a source of profit, as well as loss of time being averted. By request having been induced to allow this letter to appear in your valuable publication on ‘Cupola Practice;’ hence will try and give you the details as near as I can from memory, although I wrote an article on this subject in the ‘American Machinist,’ December 10, 1891, which I am now unable to get.

“In the latter part of October, 1891, just as we were about to put on the blast in our foundry cupola and the fan making a few revolutions, the main pulley broke, running the main shaft to the fan or blower of our cupola. After considerable trouble, loss of time and delay in trying to get a new pulley, which was

of wood pattern, we finally succeeded in getting one of the proper size, and had it put on the shaft; but the belt being a little tight, and also anxious to get off the heat, in slipping the belt on the pulley, it was cut in such a shape that it became useless for that day. By this time it was beyond our regular hour for quitting. At first there seemed no way out of the dilemma but to drop the bottom. The thought of re handling the hot material and fuel, the extra labor attached therewith, suggested the idea of holding up the charges until next morning, when repairs would be completed. After a few moments' consultation, proceeded as follows: Let me say first that the cupola was lighted at 1:45 p. m. and at 6 p. m. began the operation of banking the cupola, having had four hours and fifteen minutes time for burning the stock, and being charged with eleven tons of metal. The cupola was of the Colliau type 60" shell lined to 44" at bottom and 48" at melting zone, having six lower tuyeres, 7"x9", upper tuyeres being closed. Height of tuyeres from bottom when made up 18", blast pressure 10 oz., revolutions of blower about 2100, manufactured by the Buffalo Forge Co., and known as No. 10, the adjustable bed type. The cupola bed was made up of 600 lbs. Lehigh lump coal and 800 lbs. Connellsville coke, the succeeding charges 50 lbs. of coal and 150 lbs. coke, coal being an important factor in this heat on account of its lasting qualities. We first cleaned and cleared all of the tuyeres, packed each one with new coke, and then filled and rammed them tight with floor moulding sand to prevent any draft getting through them, and had the top of charges covered with fine coal and coke dust, and tightened that also to stop the draft in that direction. The object in using coal dust was this: should any get through into the charges, it would not cause much trouble. After all was completed, gave orders to the cupola men to be on hand at 6 a. m. next morning, clean out the tuyeres and top of cupola, and ordered the men to be ready for pouring off at 7 a. m. The next morning all were on time. I had the tuyeres poked with bars, so that the blast might have easy access to center of cupola, and started the

blast at 7:15, bottom being dropped at 8:45; total time from time of lighting cupola until bottom dropped was nineteen hours. At first the iron was long in coming down and first 500 lbs. somewhat dull, but made provision for that and put it into dies, which turned out to be very good. The balance of the heat was hot enough for any kind of casting—our line being light and heavy—and had to be planed, bored and otherwise finished with some stove repair casting in with this heat engine casting, cylinder and a class of work that requires fluid metal. I am confident that if this method is carefully followed, it can be done at all times, but would not advise it in small cupolas, less than 36" inside measurement; and should the melt be in progress, it could not be successfully done at all. Should I be placed in a similar position, would resort to the same means with more confidence and certainty of success.

"Yours respectfully,

"JOHN C. KNÖPPEL,

"*Foundry Supt. Buffalo Forge Co., Buffalo, N. Y.*"

GIVE THE MELTER A CHANCE.

There is no man about a foundry for whom we have more respect than a practical and scientific melter. He is generally a self-made man and has learned the art of melting himself. He is a man of intelligence, who, perhaps, has been a melter's helper and a close observer of the work, and when given charge of a cupola, has followed in his footsteps or improved on the methods of his predecessors. He may have been a man who was given a few instructions in melting when he first began, and has become an expert through his own efforts. He is respected by the foreman and molders, and well-paid by his employer. There is no man about a foundry for whom we have more pity than a poor melter, for he seldom melts two heats alike, and is cursed by the piece molders who have lost their work through bad iron. Gibed by the day molders, lectured by the foreman, looked black at by his employer, poorly paid, and respected by no one about the foundry, his lot is a hard one.

A poor melter is not always to blame for doing poor work, for he may have been a foundry laborer who was put to work as a melter, and never given proper instruction in the management of a cupola. Again, a good melter may be made a poor one from being interfered with by others who do not understand melting. Foundrymen in conversing with each other learn that they are melting ten pounds of iron to the pound of fuel. The foundryman not being a practical man, does not inquire the size of the heat or cupola in which it is melted, the conditions under which it is melted, or the kind of work the iron is for. He does not stop to think that the other foundryman may be lying to him, or is deceived by his melter and does not know how many pounds of iron he is melting to the pound of fuel. But he goes to his foundry and insists that iron must be melted at a ratio of 10 to 1. The conditions in his foundry may be totally different from those of the other one, and iron may not be melted at a ratio of 10 to 1 in the other foundry. The melter, if he is a practical man, knows this, or finds it out the first heat, and to hold his job shovels in extra fuel, unbeknown to any one, and if he is watched, does not get it in evenly or at the proper time, and the result is uneven melting and dull iron. Foundrymen do not always furnish their melters with proper tools for chipping out and making up the cupola, a suitable material for repairing and keeping up the lining, a proper flux for glazing the lining and making the cupola melt and chip out free, and a man who would be a good melter if given a chance, is frequently made a poor one by being hampered in his work for want of tools and material to work with. He is blamed for poor melting when it is really not his fault. Good melters frequently get into a rut or certain way of doing their work, for want of text-books and other literature on melting to read and study, or association with men of their calling, and become very poor melters. As a lawyer who does not read law-books that are up to the times and associate with his colleagues, becomes a pettifogger, so does a doctor who does not study his text-books and medical literature, diag-

noses all cases as one of two or three diseases, has one or two prescriptions which he prescribes for all cases. The man of learning, or a man who knows it all, when left to himself for years gets to know nothing; and so it is with melters when left to themselves. They forget many things they are not called upon to practice every day, and in time get into a rut or routine from which they unconsciously gradually degenerate if the mind is not refreshed by reading or contact with other melters. It should be the aim of every melter to converse with other melters upon cupola matters at every opportunity, and to read and study all literature upon the subject, whether good or bad; for, if good, he may learn something new, and, if bad, it stimulates the mind to reason why it is not good, and how it can be improved upon. It recalls to mind facts in his own experience which have long been forgotten, and he learns something, at all events. It is to the interest of every foundryman who depends upon his melter for results to keep him posted upon all that is new in the business, and he should furnish him all the new literature on the subject that comes into his office or is published.

CHAPTER XIV.

THE CUPOLA ACCOUNTS.

IN all well regulated foundries a cupola account of melting is kept and an accurate record made of each heat, and preserved for future reference. In this way, the melting is reduced to a system and the foundryman knows what is being done in his cupola each day and is able to make an estimate of the cost of melting. These records are also of value in showing the amount of fuel required for a bed and in charges when the cupola is newly lined, and the amount they should be increased as the lining burns out and the cupola is enlarged. Mixtures of various brands and grades of iron are recorded, with the result of the mixtures upon the quality of castings, and a great deal of experimental work in melting and mixing of irons is saved and better results are thus obtained. The manner of keeping these accounts varies in different foundries. In some they are kept very simply, showing only the amount of fuel and iron in each charge and total fuel consumed, iron melted, and time required in melting. Others show kind and amount of fuel used, in bed and charges, and amount of each brand or quality of iron placed in charges, total amount melted, time of lighting up, time of charging, putting on blast, first iron melted, blast off, pressure of blast, etc.

Others are still more elaborate, and not only show all the details of the cupola management, but also a report presenting cost of various castings produced, good and bad, the cost of the bad ones being charged to the good ones made of the same pattern or for the same order, and the average found.

To give foundrymen who have never used such reports an idea of how they are made out, we here give a few blank reports from leading foundries. Those of Abendroth Brothers, Port Chester, N. Y., and of Byram & Co., are filled in to show the manner of placing the various items in the blank report.

THE CUPOLA FURNACE.
 BYRAM & COMPANY,
 IRON WORKS.

435 and 437 Guoin Street.
 46 and 48 Wight Street.

DETROIT, MICH.

FUEL USED and IRON MELTED at the Foundry of

.....

IN THE COLLIAU CUPOLA FURNACE.			CHARGES.	
.....SIZE.			FUEL.	IRON.
DIAMETER INSIDE OF LINING.....54 INS.			Bed	1.....5 000
• PRESSURE OF BLAST..... OZS.			2.	2.....2000
Lighting, . . . 12 15 o'clock.			3.	3.....2000
Loading commenced 1 "			4.	4.....2000
Blasting, . . . 2 "			5.	5.....2000
Closed Tap Hole. "			6.	6.....2000
First Iron Taken, 2 16 "			7.	7.....2000
Loading Finished, "			8.	8.....2000
Blasting Stopped, "			9.	9.....2000
Dropped Bottom, "			10.	102000
			11.	112000
			12.	122000

REMARKS:.....

Dated at.....189.....

No.....

DAILY REPORT OF FOUNDRY DEPARTMENT.
LEBANON STOVE WORKS.

189

CHARGES.	LSB. OF COAL.	LSB. OF COKE.	LSB. OF SHELLS.	KIND OF PG.	KIND OF PG.	KIND OF PG.	KIND OF PG.	GATES AND SCRAP.	LSB. PER CHARGE.	
1st										
2d										
3d										
4th										
5th										
6th										
7th										
8th										
9th										
10th										
11th										
12th										
Total										
TIME OF LIGHTING,	Hrs.	MIN.		REMARKS:						
TIME BLAST PUT ON,									
TIME FIRST SHANK,									
TIME BOTTOM DROPPED,									
LENGTH OF HEAT,									
CONDITION OF IRON,									
RATIO OF IRON TO FUEL,			 Foreman.						

REPORT OF CASTINGS IN.....SHOP.

Date,190.....

THE CUPOLA ACCOUNTS.

Cupola Heat Consisted of		Coal Used		Lbs.		Good Castings		Lbs.		Cost of Moulding															
Fig	Lbs.	Coke Used	Lbs.	Bad Castings	Lbs.	" for Special Cores	Lbs.	" General "	Lbs.	Cupola Expenses	Lbs.														
Fig	Lbs.	Flux Used	Lbs.	Returns from Bottom, &c.	Lbs.	Crane Runner	Lbs.	Gang Foreman	Lbs.	Furnace Man	Lbs.														
Fig	Lbs.	Ratio Fuel to Iron	To	Loss	Lbs.	Total	Lbs.	Sand Mixer	Lbs.	Total Cost of	Lbs.														
Scrap	Lbs.	Blast on	p. m.	Bottom Dropped	p. m.	Total Cost of	Lbs.	Labor on Castings																	
Iron Melted	Lbs.																								
Iron Borrowed	Lbs.																								
Shop Order.	Moulder's No.	No. of Helpers.	No. of Pieces.	Description of Work.	Pattern No.	Weights in Detail.	Good.	Bad.	Checked.	Total No. of Hours.	Wages per Hour.	Price per Piece.	No. of Cores.	Amount of Sand in Pounds.	Amount of Hay in Pounds.	Rope in Pounds.	Fuel Used in Baking.	Wages on Cores.	Amount of Loam in Pounds.	Number of Brick Destroyed.	Cost of Loam and Cores.	Cost of Grave and Hay Cores.	Cost of Moulding.	Total Cost.	REMARKS.

The blanks for these reports and records of them are furnished to the foundry foreman or melter, and preserved in different ways. In some foundries they are furnished in separate sheets, and when filled out and returned are kept in files provided for the purpose. In other foundries they are made out in book form and filled in by the foreman or foundry clerk. Such reports can be kept by a foundry foreman when provided with a small office for doing such work; but when there is no office, as is frequently the case, a report book kept by the foreman soon becomes so soiled that it is useless for reference, and report blanks are generally furnished in separate sheets and either filed or transferred to the report book by the foundry clerk. When only a record of fuel used and iron melted is kept, the report is generally made on a slate upon which lines are scratched similar to those in a printed report, and name and amount of various grades of iron and fuel filled in with the slate pencil. The fuel to be used and amounts of various irons to be melted in each charge are placed upon the slate by the foreman and given to the melter to charge the cupola by, and after the heat is melted the slate is sent to the foundry office to be copied into the cupola account book. This latter is the oldest way of making out these reports.

A cupola account is of no value if not correctly kept, and it should be the aim of every foundry foreman to see that the report he makes of fuel consumed and iron melted is correct, and not, as is frequently done, endeavor to make a good showing for himself, of melting a large per cent. of iron with a small per cent. of fuel, and permit his melter to shovel in extra fuel to make iron sufficiently hot to run the work. Foundrymen can readily ascertain the amount of fuel consumed by comparing the amount reported with the amount purchased. False reports only reduce the foreman in the estimation of his employers, and are frequently the cause of him losing his position.

COST OF MELTING.

There is probably less known about the actual cost of melt-

ing iron in cupolas for foundry work than about any other branch of the foundry business. But few foundrymen make any attempt at keeping a cupola or melting account. Many of those who do, keep it in such a way that they not only fail to learn the cost of melting, but are misled by the account to suppose their melting costs them a great deal less per ton than it really does. In the majority of foundries the melting is left entirely in the hands of the melter, who as a rule has no system for doing the work, and has no control over his assistants or interest in having them do a fair day's work. In many of the foundries we visit, twice the number of men are employed as cupolamen as are employed in melting the same amount of iron in other foundries, where the facilities for handling the stock are almost the same, and the expense of lining and daubing material is frequently double with one melter what it is with another in the same sized cupola with the same sized heats.

In many foundries the fuel is not weighed, but is measured in baskets, or the number of shovels counted and the weight estimated. When the fuel is measured in baskets, the baskets always stretch and enlarge, and an old basket frequently holds one-third more than a new one; from 10 to 20 pounds more can easily be piled on the top of a basket after it is filled. Foundrymen who charge their fuel by the basket always use more fuel than they estimate they are using; when the shovels are counted, each shovel may be made to weigh more than is estimated, and a few extra shovelfuls are always thrown in, for fear some were not full. When too much fuel is used in a cupola there is not only a wastage of fuel, but there is slow melting, increased destruction of the lining, and an increased wear and tear of the blast machinery. For these reasons every pound of fuel that goes into the cupola should be accurately weighed. Even when the fuel is supposed to be accurately weighed, there should be some check on the melter, for he will shovel in extra fuel if not watched.

At a foundry we recently visited in New Jersey a supposed accurate account of the melting had been kept for a year; at the

end of the year the president of the company had figured up the amount of fuel consumed in the cupola and compared it with the amount purchased, and found they were short 260 tons. At another foundry, where the melter always reported melting 7 pounds of iron to 1 pound of anthracite coal, they ran short 300 tons in a year. This kind of work should be prevented by checking up the melter's report and comparing it with each car-load of fuel consumed.

A cupola book should be provided, with blank spaces for recording the weight of coal or coke in the bed and charges, and the weight of each brand of iron, No. 1, 2 or 3 and scrap, showing the exact mixture of each charge and heat. A note should also be made of the quality of iron produced from the mixture. Such a record is of great value in making mixtures and charging a cupola, if it is properly kept.

The cost of melting per ton is figured in a number of different ways, but to be of any practical value the entire cost of melting should be figured on as follows:

Interest on cost of cupola plant and depreciation in value of same.

Fire brick for relining and repairs.

Fire clay, loam and sand for cupola and ladles.

Repairs to cupola, blast pipe, elevator, scaffold, runway, blower, &c.

Belts, oil, &c., for blower.

One-fourth the entire cost of engine.

Tools, wheelbarrows, buckets, hose, shovels, forks, rakes, hoes, sledges, picks, bars, trowels, bod sticks, tap bars, &c.

Wood for lighting up and drying ladles.

Coal or coke consumed in melting.

Labor employed in removing the dump, making up cupola, milling dump and gates, collecting gates, scrap and bad casting from foundry, placing iron and fuel on scaffold, charging, breaking and piling iron in yard, breaking up bad castings, daubing ladles, &c.

When the cost of all these items has been learned, and the

amount divided by the number of tons melted, it will be found that the cost of melting is about \$2 per net ton of iron in the ladles. In foundries with all the modern improvements for handling the stock the cost is a little less than \$2 per ton, and in foundries with none of the improvements for handling the stock and no system in melting, the cost per ton is as high as \$3. When there is doubt as to the accuracy of weights in charging, the weights should be compared with the fuel purchased and castings sold, and the cost of melting may be figured on the weight of castings sold in the place of the amount of iron melted. To make a cupola report of value, the fuel, labor and tool accounts should be kept separate, and an effort made to reduce the expense of each account.

CHAPTER XV.

SCALES AND THEIR USE.

THERE is nothing more essential to the good melting and mixing of iron, than an accurate weighing scale upon the scaffold near the cupola charging door. The best for this purpose are the platform scales mounted on large wheels, with the platform about two feet above the floor or on a level with the charging door. For foundries that make a large quantity of gates, spews and light scrap to be remelted, an iron box made of boiler plate and open at one end for shoveling out iron and fuel should be placed upon the scales. A one or two ton scale is sufficient for charging almost any cupola, for the iron and fuel are weighed in charges or drafts that seldom exceed this weight, and when large pieces are charged they are generally weighed on the scales in the yard. Scales placed in the floor on the scaffold upon which barrows of iron and fuel are weighed as they are brought on the scaffold, give the weight of the stock used, but they are of no value in dividing it into charges if the stock is not charged direct from the barrows into the cupola, which is seldom done.

The melting of iron in a cupola, when reduced to an art, consists in melting the greatest possible amount with a given amount of fuel; and this can only be done by first learning the amount of iron that can be melted with each pound of fuel, and placing that amount upon the fuel in the cupola at the proper place to be melted. If all the fuel required to melt ten or twenty tons of iron were first placed in a cupola and all the iron put upon it in one lot, it would be so high above the melting zone that none of it could be melted until fully one-half of the fuel had been burned away and the iron permitted to settle

to the melting zone, in which case all the fuel consumed before melting began would be wasted, and the iron would not have a sufficient amount of fuel to melt it.

For this reason the fuel and iron are divided into charges and placed in a cupola in layers, each layer of fuel being only sufficient to melt the layer of iron placed upon it, when it descends into the melting zone. If the charge of fuel be too heavy, the excess must be consumed before the iron can be melted by it; and if the charge of iron be too heavy, all of it cannot be properly melted with the charge of fuel. It is, therefore, necessary that the layers of fuel and iron should be of exactly proper proportions to do economical melting.

There are many foundrymen who do not understand this theory of melting, but think fuel placed in a cupola melts iron no matter how it is put in, and trust to their melter to guess the weight of fuel consumed and iron melted in an entire heat. Others have the fuel and iron weighed in the yard or upon the scales placed in the floor of the scaffold, and permit the melter to guess the respective weights of fuel and iron in charging. In the first case an excess of fuel is always consumed, the melting is slow and the amount of iron charged is often more than required to pour off the work; or it is insufficient, and more iron has to be charged after the stock is low in the cupola, and the destruction of cupola lining is greater than if the iron had been charged at the proper time. In the second case the melting is irregular, and the temperature of the iron uneven, even if only a proper amount of iron and fuel to melt it is placed upon the scaffold, for the melter cannot in charging divide it evenly. No melter can guess the weight of a promiscuous lot of scrap, spews, gates, etc., or accurately estimate the weight of pig iron by counting the pigs. The counting of shovels, riddles or baskets of fuel in charging is the greatest fallacy of all; for riddles and baskets always hold more the longer they are in use, and shovels hold less. The melter makes no allowance for the increase in size of riddles or baskets, but always puts in a few extra shovelfuls to make up for reduced size of the shovel,

as it wears down. Even when these articles are new, a few pounds more or less may be put on, so that it is simply guess-work at best.

Placing upon a scaffold old worn-out scales that are unfit for use in other parts of the works and frequently only weigh correctly on one side or end, is a mistaken economy frequently practiced by foundrymen. The weighing of cupola stock upon such scales is only guess-work, and the saving in fuel and improvement in melting would soon pay the cost of accurate scales.

CHAPTER XVI.

EXPLOSION OF MOLTEN IRON.

MOLTEN iron is a very explosive body, and under certain conditions explodes with as loud a report and as much violence as gunpowder. Under other conditions it is not at all explosive, but the conditions under which it explodes must be fully understood and avoided by melters and moulders to prevent dangerous accidents.

A stream of iron flows from a tap-hole and spout smoothly if the front and spout lining have been properly dried. When wet the iron explodes as it emerges from the tap-hole, and is thrown in small particles some distance from the cupola. The instant a stream of iron strikes a wet spout it explodes and the entire stream is thrown from the spout in all directions with great force. In a damp spout the iron boils and small particles may be thrown off, but the explosion is not so violent as from a wet spout.

A wet bod causes molten iron to explode the instant it comes in contact with the stream, and it is impossible to close a tap-hole with it. A bod containing a little too much moisture causes a less violent explosion and a tap hole may be closed with it, but in closing it, the iron explodes and is frequently thrown from the tap-hole with great force past the sides of the bod before it is pressed into the hole. When the bod is in place in the hole one or more small explosions frequently take place, and the bod-stick must be firmly held against the bod to prevent it being blown out. The kick or thump felt against the end of a bod-stick when pressing a bod into place is due to these explosions, and not to the pressure of molten iron in the cupola, as is generally supposed. Bod

material should be no wetter than molding sand properly tempered for molding.

When the iron is very hard, a stream of very hot iron throws off a great many sparks from a dry spout. These sparks are caused by an explosion of the iron due to the combination of oxygen with the combined carbon of the iron, and the sparks are the oxide of iron. They contain very little heat, and melters or molders do not hesitate to enter showers of these sparks to stop in or catch the stream of iron. The sparks from explosions caused by dampness are of an entirely different character, and burn the flesh or clothing wherever they strike.

A wet, cold or rusted tapping bar thrust into a stream of iron in the tap-hole or spout, causes the iron to explode. Tap bars should, therefore, always be heated before they are put into the stream of iron.

When iron falls from a spout upon a hard floor, it spatters and flies in small particles to a considerable distance from the place it first strikes, and it is dangerous to go near the spout as long as the stream is falling upon the floor.

When iron falls from a spout upon a wet, muddy floor, it explodes instantly, and small particles of molten iron may thus be thrown a hundred feet from the cupola. If the stream continues to run upon the floor, one explosion follows another in rapid succession, or a pool of molten iron is formed, which boils and explodes every few minutes, as long as there is any moisture in the floor and the iron remains liquid. The floor under a spout should always be made of loose dry sand, with a hole in it to catch any iron that falls from the spout.

The floor under a cupola should always be dry, and when paved with brick or stone, should be covered with an inch or two of dry sand before dumping, to prevent fluid iron or slag in the bottom of the cupola spattering or exploding when dumped.

Molten iron explodes violently when a piece of cold, wet or rusted iron is thrust suddenly into it, as the writer has reason to know from practical experience, when working at stove

moulding in the winter of 1855 and 1867. Knowing that a rusty or wet skimmer made iron explode, we always took the precaution of putting our skimmers into the foundry heating stove and heating them to a red heat before catching iron. One day we had taken this precaution, heating a skimmer to a red heat and putting it in a convenient place for use. A small boy who was around the foundry and sometimes skimmed our iron before pouring, saw the red-hot skimmer, and took it out and put it in the snow while we were catching a ladle of iron. As soon as we set the ladle on the floor he ran in with the skimmer dripping wet, and before we could prevent him, thrust into the molten iron. The iron exploded instantly and was thrown all over us as we leaned over the ladle, burning us so severely that we were not able to be out of the house for several weeks, and we still carry the scars from those burns. The iron was thrown with great violence, and passed through our clothing and a thick felt hat, like shot from a gun. The exploded iron passed over the boy's head and he was burned slightly, but never was seen about the foundry again, and probably never became an iron moulder.

Molten iron when poured into a damp or rusted chill-mould or a wet sand-mould, explodes and is thrown from the mould and escaping from a mould upon a wet floor or into the bottom of a wet pit, explodes. In the foundry of Wm. McGilvery & Company, Sharon, Pa., a deep pit for casting rolls on end was put in the foundry floor and lined with boiler plate. The first roll cast in this pit was one eleven feet long, weighing about five tons, moulded in a flask constructed in ring sections and clamped together. The mould was not properly made and clamped, and when almost filled with molten iron gave way near the bottom and permitted the iron to escape into the pit, the bottom of which was covered with wet sand or mud. The iron at once exploded and forced its way up through ten feet of sand that had been rammed about the mould in the pit, and was thrown up to the foundry roof at a height of forty feet. The molten iron continued to explode until nearly four tons

were thrown from the pit in small particles, and the foundry burned to the ground.

Molten iron explodes when poured into mud or brought in contact with wet rusted scrap, but does not explode when poured into deep or clean water. At a small foundry that stood near the Pittsburg & Erie canal, in Sharon, Pa., many years ago, a wager was made by two moulders that molten iron could not be poured into the water of the canal without exploding. A ladle of iron was accordingly taken to the canal and poured into the water without any explosion taking place. A few days later an apprentice boy who had witnessed the experiment undertook to pour some into water in an old salt kettle that sat in the yard near the foundry and contained rusted scrap and mud under the water. An explosion at once took place that almost wrecked the foundry. The water in this case was not of sufficient depth to destroy the explosive property of the molten metal before it came in contact with the rusted scrap and mud at the bottom of the kettle.

Moulders frequently pour the little iron they have left over, after pouring off their day's work, into a bucket of water to heat the water for washing in cold weather. This was a common practice of the moulders in the foundry of James Marsh, Lewisburg, Pa., until one day iron was poured into a bucket of water in which clay wash had been mixed and contained mud at the bottom. It exploded instantly with so great a violence that all the windows were blown out of the foundry, and this stopped the heating of water for washing, in that way, at that foundry.

At another foundry, iron poured into clear water in a rusted cast-iron pot, exploded, doing great damage.

At the foundry of North Bros., Philadelphia, Pa., during the flood in the Schuylkill river, June, 1895, the cupola was prepared for a heat and the blast put on; but before the heat could be poured off water soaked into the cupola pit and had to be bailed out to prevent the pit being filled. The heat was all poured before water came upon the moulding floors, but the

bottom of the cupola pit was soaking wet, and the melter, in his eagerness to leave the foundry before it was flooded, dropped the bottom without drawing off the molten iron remaining in the cupola. The instant the molten iron and slag dumped from the cupola came in contact with the wet floor of the pit, a violent explosion took place, scattering molten iron, slag and fuel in all directions and blowing all the windows out of the foundry. Had the melter taken the precaution to have drawn off all the molten iron before dumping, and thrown a few shovelfuls of dry sand under the cupola to receive the first slag to fall upon the bottom, this explosion would not have taken place.

At the foundry of The Skinner Engine Co., Erie, Pa., a violent explosion took place in their cupola which almost entirely wrecked it. At the time of this explosion, a lot of small steam cylinders were being melted in the cupola, and in some of these cylinders the ports of the steam-chest had been closed by rust, leaving the steam-chest filled with water, from which it could not escape. The foreman, David Smith, had given the melter orders to see that each of these cylinders was broken before being put into the cupola, but this order had by the melter been disregarded, and the explosion was attributed to the water confined in one of the cylinders being converted into steam and exploding with such violence as to wreck the cupola.

At the foundry of The Buffalo School Furniture Co., Buffalo, N. Y., an explosion took place in 1895 in their sixty-inch cupola, about seven minutes after the blast was put on for a heat, which blew the heavy cast-iron door from the tuyere box, on each side of the cupola; and also blew out the front and broke the heavy cast-iron bottom doors. A number of men who chanced to be near the cupola were severely burned, but fortunately none were killed. This explosion was attributed to a number of causes, one of which was the formation of gas in the cupola before the blast was put on, which was exploded by the addition of oxygen from the blast. But this could hardly

have been the cause, for the blast had been on fully seven minutes before the explosion occurred, and had this been the cause the explosion would have taken place almost as soon as the blast was put on. Another cause given for the explosion was that dynamite had been placed in the cupola concealed in some pieces of scrap-iron. This may have been the case, or some other explosive body may have been concealed in the scrap; but it is just as probable that it was due to steam generated from water confined in some piece of the scrap, by rusting of the opening through which it was admitted to the casting; as in the case at the foundry of The Skinner Engine Co.

A damp ladle causes iron to boil, and if the daubing is very thick may cause it to explode. A wet daubing or water in a ladle explodes the iron the instant it touches it. Wet or rusted scrap-iron placed in a ladle to chill the molten iron, causes the iron, if tapped upon it, or if thrown into a ladle of iron, to explode. Such an explosion may be prevented by heating the scrap to a red heat just before using it to chill the iron.

CHAPTER XVII.

DIFFERENT STYLES OF CUPOLAS.

BEFORE describing the cupolas now in use, a short account of the old-fashioned cupolas may be of interest to many founders who have not had an opportunity of seeing them or observing their defects, all of which defects should be avoided in modern ones.

In Fig. 25 is seen the old style cupola in general use throughout the country many years ago, some of which are still in use in old-time small foundries. A square cast-iron bottom plate, with opening in the centre and drop door, is placed upon a brick foundation at a sufficient height above the floor for the removal of the dump. An iron column is placed upon each corner of the plate, and upon these columns is placed another cast-iron plate, having an opening in the centre for the top of the cupola. Upon this plate a brick stack is constructed to carry off the flame and unconsumed gases. The stack plate was sometimes placed upon brick columns or brick walls, built on each side of the cupola, through which openings were made for manipulating the tuyere elbows. The stack was built square and of a much larger size than the inside diameter of the cupola. It was not subjected to a very high heat, and was built of common red brick. These large stacks were not built very high and threw out very few sparks at the top, which was due to their size. The cupola was placed between the bottom and stack plate, and the casing was formed of cast-iron staves, which were held together by wrought-iron bands, drawn tight by draw-bolts placed through the flanged ends of the bands. When the casing was made tapering, the bands were placed in position when hot and shrunk on. The cupolas were only from six to eight feet high, and those of

small diameter, were generally made larger at the bottom than

FIG. 25.

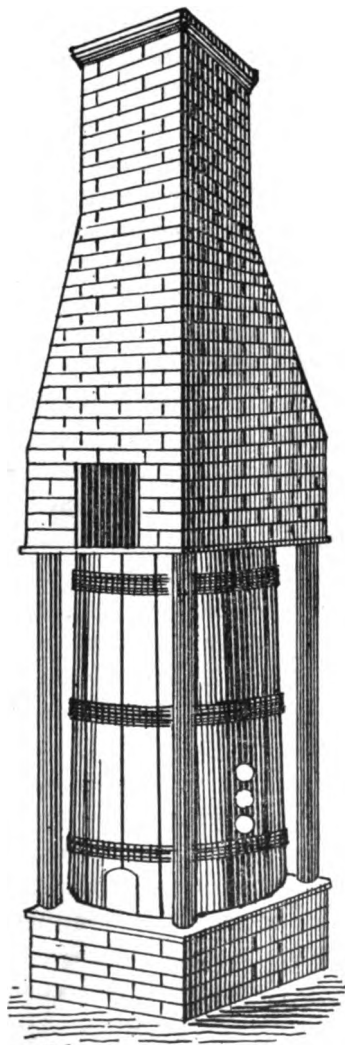

OLD STYLE CUPOLA.

at the top, to facilitate dropping, and that a large quantity of

molten iron might be held in the cupola for a heavy casting. The charging door was placed in the stack just above the stack plate. From two to four tuyeres were put upon each side of the cupola, one above the other, and from eight to ten inches apart. The tuyeres were supplied from a blast-pipe on each side, to which was attached a flexible leather hose and tin or copper elbow for conducting the blast into the tuyeres. A small hole was made at the bend of the elbow for looking into the tuyere, and closed with a wooden plug. The tuyeres were frequently poked with an iron bar through these openings.

When light work was to be cast, the upper tuyeres were closed with clay or loam, and the blast sent through the lower tuyere. When it was desired to accumulate a large amount of molten iron in the cupola for a heavy piece of work, the lower tuyeres were used until the molten iron rose to the lower edge. The tuyere elbows were then withdrawn and shifted to the next tuyere above, and the lower tuyere closed with clay or loam rammed in solid. The shifting of the tuyere elbows was continued in this way until the necessary amount of molten iron for the work to be cast was accumulated in the cupola. When a heavy piece of work was to be cast, a sufficient quantity of fuel was placed in the cupola to bring the top of the bed some distance above the top of the highest tuyere to be used; on the bed two cwt. of iron was charged, and a shovelful of coke and a cwt. of iron charged throughout the heat. The charging was raised a little in different sized cupolas, but the fuel and iron were always mixed in charging. The large body of molten metal frequently pressed out the front and sometimes the plugging of the lower tuyeres. After the iron was tapped the stock in the cupola dropped so low that no further melting could be done with the blast in the upper tuyeres, and frequently the lower tuyeres were so clogged that they could not be opened, and the bottom had to be dropped.

In practice it was found that in a cupola constructed large at the bottom and small at the top for the purpose of retaining a large amount of molten iron, the stock did not spread to fill the

cupola as it settled, and a great deal of heat escaped through the space made between the lining and stock by the settling of the stock. It was also found that the shifting of tuyeres required such a high bed that the cupola melted slowly, and a greater per cent. of fuel was consumed in large than in small heats.

THE RESERVOIR CUPOLA.

To overcome the objections to the tapering cupola and shifting of the tuyeres, and still be able to hold a large amount of molten iron in a cupola, the reservoir cupola, Fig. 26, was designed.

The casing of this cupola was made of wrought iron, and the bottom section, to a height of from twelve to twenty-four inches, was constructed of one-third greater diameter than the upper section or cupola proper. This arrangement admitted of a large body of molten iron being held in the cupola without shifting the tuyeres. The metal was spread over a larger surface, which reduced the pressure on the breast, and did not leave the stock in so bad a condition for melting after a large tap was made as in the tapered cupola, and melting could be continued after a large body of iron was tapped. The reservoir cupola did faster and more economical melting in large heats than the tapered cupola, but in small heats the amount of fuel required for the bed was too large for economical melting.

At the present time cupolas are made of the same diameter from the bottom to six or eight inches above the tuyeres. The tuyeres are placed at a height to suit the general run of work to be done, and when a heavy piece is to be cast, the iron is held in ladles and covered with charcoal or small coke to exclude the air. The molten iron can in this way be kept in almost as good condition for pouring as in the cupola, and the cupola is kept in better condition and melts faster and longer.

FIG. 26.

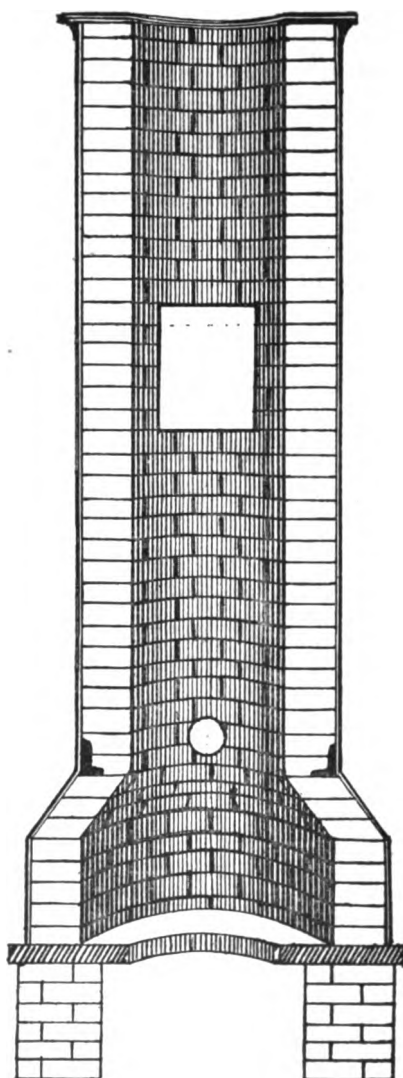

RESERVOIR CUPOLA.

STATIONARY BOTTOM CUPOLA.

In Fig. 27 is shown the old style English cupola. This cupola is constructed upon a

FIG. 27.

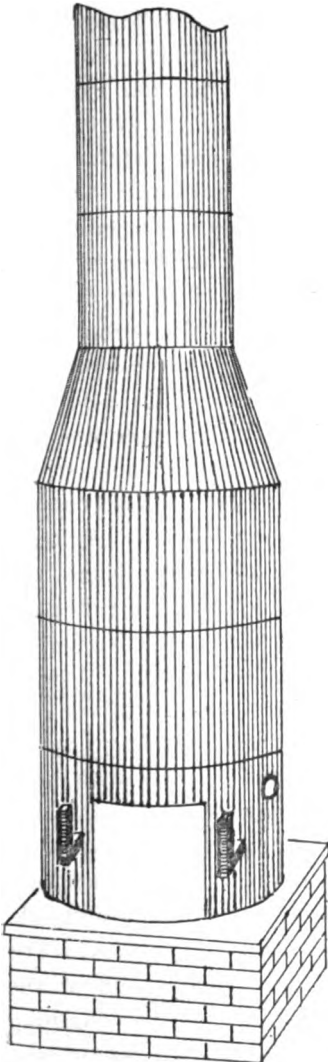

STATIONARY BOTTOM CUPOLA.

solid foundation of stone or brick work and has a stationary bottom of brick, upon which is made a sand bottom. The refuse, consisting of ash, cinder and slag, remaining in the cupola after the iron is melted, is drawn out at the front in place of dropping it under the cupola, as is now generally done with the drop-bottom cupola. These cupolas are generally of small diameter. The opening in front for raking out is about two feet square, and when the cupola is in blast, is covered with an apron of wrought iron. When the cupola has been made up for a heat, shavings, firewood and a small amount of coke are placed in it and ignited with the front open; when the coke is well alight, a wall is built up with pieces of coke even with the inside of the cupola lining.

FIG. 28.

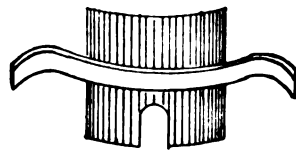

APRON.

The bed of coke is then put in, a round stick is placed in the spout to form the tap hole, and the front is then filled in with new molding sand or loam even with the casing, and rammed solid. The apron, Fig. 28, is then placed in position over the loam and wedged tight against it, to prevent it being forced out by the pressure of molten iron in the cupola. After the breast-plate is placed in position, the tap hole and spout are made up in the ordinary way. Some melters prefer to place the apron in position before lighting the fire, and put the breast in from the inside when making up the sand bottom. It is then rammed solid against the apron and made up to the full thickness of the brick lining of the cupola. When the heat has been melted the breast-plate is removed and the loam front dug out. After the loam front has been broken away, a sheet-iron fender is placed in front of the cupola to protect the workmen from the heat, and the raking out process begins. This is done by two men with a long two-pronged rake. If the refuse hangs in the cupola, it is broken down from the charging door with a long bar, or by throwing in pieces of pig iron. These cupolas were extensively used in England, but never to any extent in this country. We saw one in Baltimore a few years ago, and believe this is the only one in use in this country; but they are still in general use in England.

EXPANDING CUPOLA.

Fig. 29 is a sectional elevation of the expanding cupola, which is said to have melted very rapidly and with very little fuel. This peculiar form was designed to admit of the charging of a large quantity of iron before putting on the blast, for the purpose of utilizing all the heat produced by the combustion of the fuel. These cupolas were built of common brick, banded with wrought-iron bands and lined with firebrick. The diameter at the charging door was sixty inches and at the tuyeres thirty inches, or one-half the diameter at the charging door. Below the tuyeres the lining expanded to forty or even fifty inches, to give room for molten metal. The bottom was

FIG. 29.

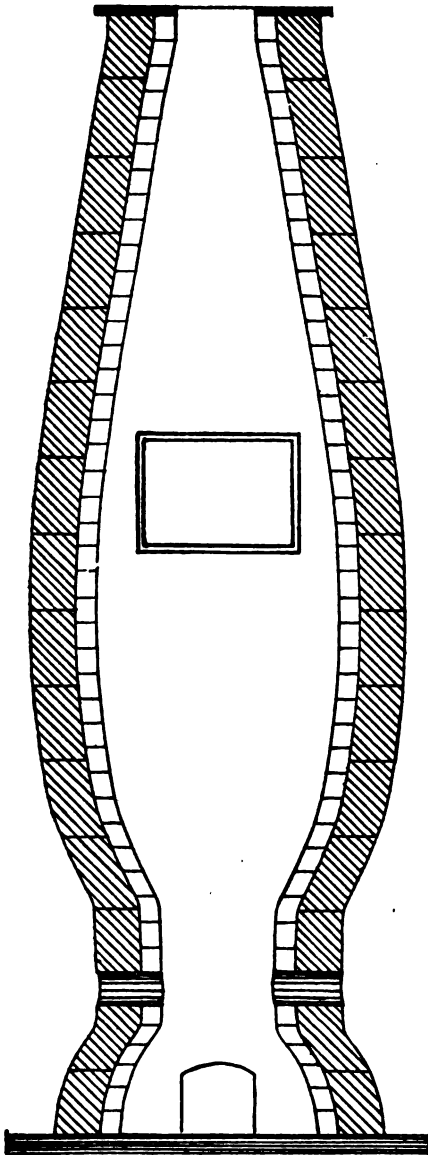

EXPANDING CUPOLA.

stationary, and the refuse after melting was drawn at the front. The cupola expanded from a level a little above the tuyeres to the bottom of the charging door, thence to the top of the stack it gradually contracted.

The greatly increased diameter at the charging door certainly admitted of a large quantity of iron being placed in the cupola at one time, and the utilization of a very large per cent. of the heat in melting. The even taper of the lining insured the even settling of the stock, so that good melting should have been done in this cupola; but the best results obtained appear to have been about six and a half pounds of iron to the pound of coke.

This old form might be used to advantage in the construction of very large cupolas; but in the ordinary sized cupola, practically the same results are obtained by boshing or contracting the lining at the tuyeres, and making it straight from the top of the boshes to the charging door.

IRELAND'S CUPOLA.

Ireland's cupola, for which the inventor took out a number of patents in England about 1856, and which was largely used there about that time, and is still the leading cupola in England, was constructed of a variety of shapes and sizes, but probably the best design is that shown in sectional view Fig. 30. It is built with a bosh and contraction of the diameter at the tuyeres, and has a cavity of enlarged diameter below them to give increased capacity for retaining molten metal in the cupola.

The cupola, of which a section is shown, was twenty-five feet high from bottom plate to top of stack, twelve feet from bottom plate to sill of charging door. The shell was parallel and fifty inches diameter to the charging door, thence it gradually tapered to two feet three inches at the top. There were two rows of tuyeres eighteen inches apart, eight in the upper row two inches diameter, and four in the lower row six inches diameter. The cupola was constructed with stationary bottom and draw front.

FIG. 30.

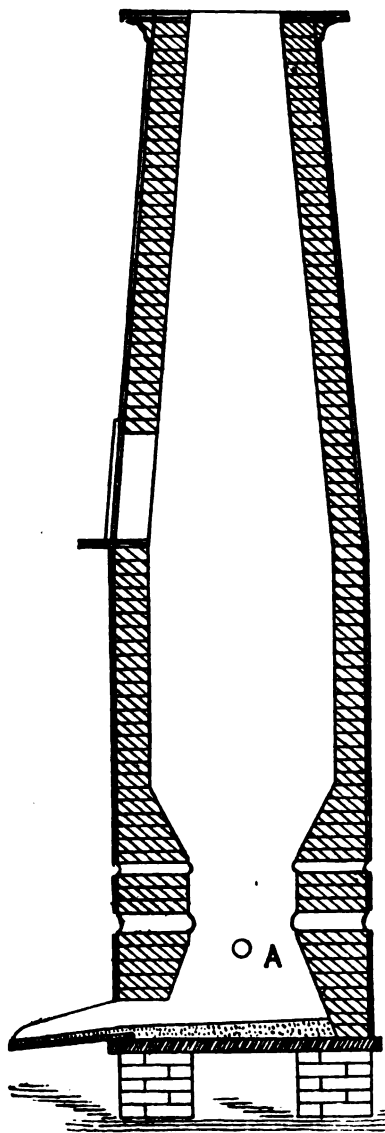

IRELAND'S DOUBLE TUYERE CUPOLA.

It was at first proposed to use a hot blast in the top row of tuyeres, but it was found to be difficult and expensive to heat the blast, and that nothing was gained by using the upper row with a cold blast, and they were closed and the cupola constructed with only the lower row of tuyeres. The interior shape was slightly modified to give more space for retaining molten metal, while, at the same time, retaining the boshes and increasing the diameter of the bottom of the cupola, as seen in the Fig. 30. Two of these cupolas were used by the Bolton Steel and Iron Company in England, in melting the iron for a large anvil block weighing two hundred and five tons, for which two hundred and twenty tons of metal, including eight tons Bessemer steel, were used.

The cupolas were each seven feet outside diameter, three feet nine inches diameter below the boshes in the crucible, and five feet diameter above and below the crucible. The blast was supplied from an external air-chamber, extending round the casing and delivered into the cupolas through two rows of tuyeres placed eighteen inches apart, sixteen in the upper row of three inches diameter, and four in the lower row of eight inches diameter. The metal was melted in ten hours and forty-five minutes from the time of putting on the blast until the mold was filled, and only one hundred and twenty-five pounds of coke consumed per ton of metal. Slag was tapped from the slag hole *A* below the tuyeres throughout the heat.

IRELAND'S CENTER BLAST CUPOLA.

In Fig. 31 is seen a sectional elevation of Ireland's cupola with bottom tuyere. The height from bottom plate to top of stack is twenty-seven feet, from bottom plate to sill of charging door twelve feet. The casing is parallel from the bottom plate to charging door, and thence it gradually tapers to the top; diameter of casing up to charging door four feet six inches, tapering to two feet six inches at the top of stack. The inside diameter at bottom of crucible, on the cupola hearth *L*, is two feet six inches, contracting to two feet three inches at spring of

FIG. 31.

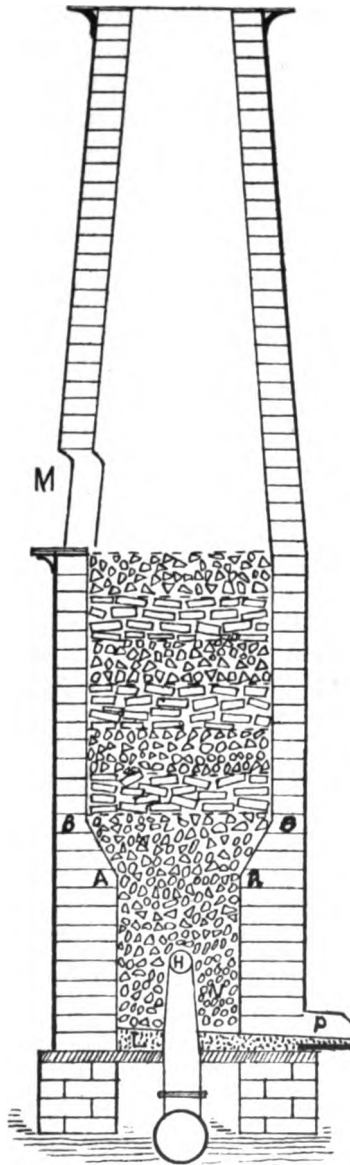

IRELAND'S CENTER BLAST CUPOLA.

the bosh *AA*, and three feet nine inches diameter from top of bosh to charging door, whence it tapers to one foot nine inches at top of stack. Height of crucible four feet five inches, length of boshes from *AA* to *BB*, eighteen inches; height from top of bosh to charging door, six feet seven inches. The blast is supplied from one tuyere placed in the center of the bottom of crucible.

The tuyere hole through the iron bottom is nine inches diameter, into which is passed a seven and a half-inch water tuyere, the mouth of which, *H*, is two feet above the sand bottom *L*. A slag hole *N*, five inches diameter, is placed just below the level of the mouth of the tuyere. *P* is the tap-hole and spout.

This cupola melted three tons of iron per hour with two and a-half cwt. of coke per ton, but it does not appear to have given satisfaction, for it never came into general use in England or this country, and Mr. Ireland changed his plans and constructed his cupolas with side tuyeres.

VOISIN'S CUPOLA.

In illustration Fig. 32 is seen a sectional elevation of Voisin's cupola, in which very good melting has been done. The shell is constructed of boiler plate with an external air chamber of the same material, extending all the way round the body of the cupola. This air chamber is supplied from two pipes, one on each side of the cupola. Two sets of tuyeres lead from the air belt into the cupola. The lower set are oblong, four in number, placed at equal distances apart and at right angles to the air belt. The upper set are round, of less capacity than the lower set, are placed horizontally through the lining and diagonally to the lower set, so that they are between them at a higher level.

Mr. Voisin claims through this arrangement of the tuyeres, that the escaping gases are burnt in the cupola, creating a second zone of fusion with those gases alone, and the second set of tuyeres obviates to some extent the evil effect of the formation of carbonic oxide in the cupola.

FIG. 32.

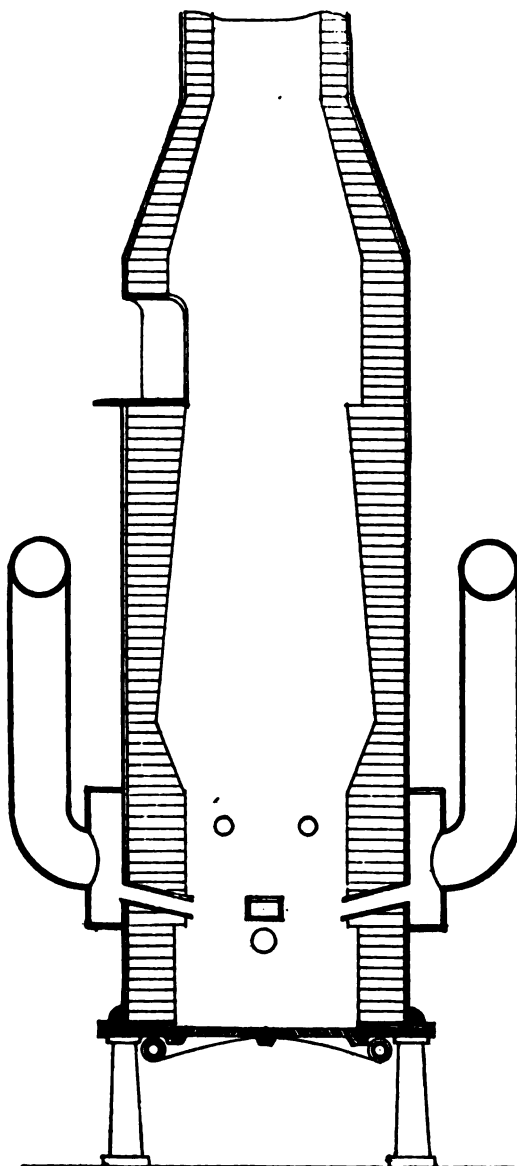

VOISIN'S CUPOLA.

This cupola is constructed in slightly varying shapes inside the lining, but the following dimensions give a general outline of it: Vertical dimensions from bottom to offset below tuyeres, one foot ten inches; offset below tuyeres to lower end of bosh, two feet four inches; length of bosh, one foot two inches; top of bosh to charging door, six feet ten inches; bottom of charging door, to bottom of stack, two feet seven inches: taper to stack, three feet ten inches. Horizontal dimensions: below tuyeres, two feet; at tuyeres, one foot eight inches; at top of bosh, two feet four inches; at bottom of charging door, one foot ten inches; at charging door, two feet seven inches.

The casing is made straight from the bottom plate to taper to the stack, and to get the above dimensions it has to be lined with brick made especially for this cupola.

Mr. Voisin has invented a number of different cupolas, but this one is said in melting to give the best results.

WOODWARD'S STEAM JET CUPOLA.

In Fig. 33 is seen a sectional view, showing the construction of the Woodward steam-jet cupola in use to some extent in England. This cupola is worked by means of an induced current or strong draught caused by a steam-jet blown up the cupola stack, which is very much contracted just above the charging door. There are several different modes of applying the steam-jet, but the general principle will be at once understood from the figure (33). The cupola is constructed upon the general plan of the English cupola, with a stationary bottom and draw front. Two rows of tuyeres or air-inlets, as they are termed, are placed radially at two different levels. In the lower row there are four openings, varying in size from five to eight inches in diameter, according to the size of the cupola. In the upper row there are eight, varying in diameter from three to five inches. Each of the air-inlets is provided with a cover outside, which can be closed when it is desired to shut off the draught. The upper row of air-inlets is placed from ten to

FIG. 33.

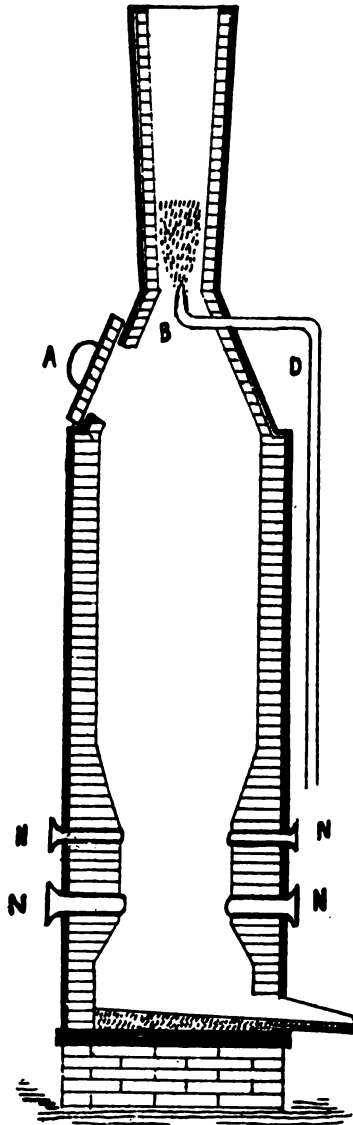

WOODWARD STEAM-JET CUPOLA.

fifteen inches above the lower row. The lining is contracted at the air-inlets to throw the air to the center of the stock, and enlarged below the air-inlets to admit of the retention of a large amount of molten iron in the cupola.

The charges of fuel and iron are put in at the charging door *A* in alternate layers in the ordinary way, and the door tightly closed and luted to prevent the admission of any air. The steam is then turned on through the nozzle *B* connected with the boiler by steam-pipe *D*, and the air-inlets *N* opened for the admission of air. When the cupola is working, the draught has to be regulated by the melter and care taken to close any air-inlets near which iron is seen to accumulate in a semi-fluid state. The temperature at the spot where the iron chills will soon rise to a degree that will cause the iron to run freely, when the air-inlet may be again opened. All the iron to be melted is put in and the door closed before the steam is turned on. The charging may be continued throughout the heat, but the opening of the door has the same effect on the stock as shutting off the blast in the ordinary cupola, and the melting stops. The repeated opening of the door soon gets the cupola into bad working order and it bungs up in a short time.

When it is desired to use the cupola for continuous melting or for a larger amount of iron than can be put in at one time, it is constructed with a side flue and feeding hopper, as shown in Fig. 34. The general construction and air-inlets are the same as those shown in Fig. 33. The stack is removed and the feeding hopper *A* with a sliding door *B* at the bottom, to be worked by the lever *D*, is placed on top of the cupola. The flue *H* near the top of the cupola connects it with the stack *M*, and the draught is induced by a steam-jet from the nozzle *N* attached to the steam-pipe *P*. When filling the cupola, the bottom of the hopper is left open and the charges put in in the ordinary way until the cupola is filled. The bottom door of the hopper is then closed, and when the cupola is melting the charges of fuel and iron are put into the hopper and dropped into the cupola as the stock settles, and the door is at once closed to exclude the air at the top of the cupola.

FIG. 34.

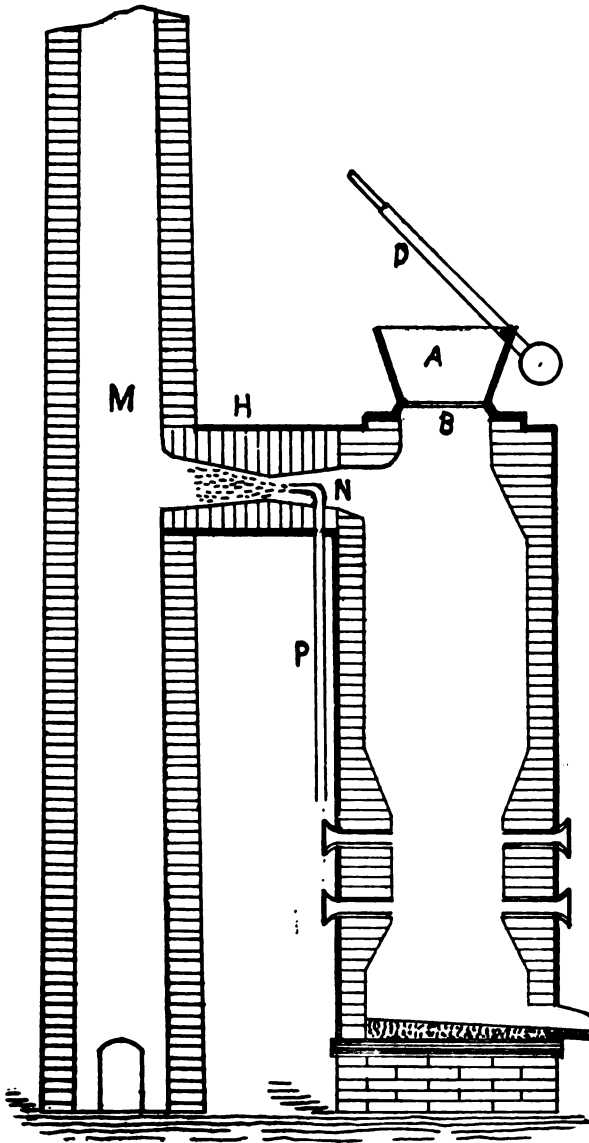

WOODWARD'S STEAM-JET CUPOLA.

It is asserted by those interested in this cupola that it effects a great saving in fuel over the ordinary blast cupola. The consumption of coke in melting a ton of iron is placed at one hundred and fifty pounds, a very low rate of fuel; but the same results are also claimed to have been obtained in blast cupolas of good design when properly worked.

The steam required to create the draught is only equal in quantity to what would be required by an engine for driving a fan or blower of sufficient power to work an ordinary cupola of the same size. Considerable saving is effected in the first cost of engine and fan or blower, besides the saving in wear and tear of machinery.

The objection to this style of cupola is the slow melting, for it cannot be forced beyond a certain point, and when a large amount of iron is to be melted the cupola must be kept working all day. This does not meet the views of the foundrymen of this country, who desire to melt their heats in from one to two hours from the time the blast is put on until the bottom is dropped, and with that object in view construct their cupolas.

TANK OR RESERVOIR CUPOLA.

In Fig. 35 is seen a sectional elevation of a reservoir cupola. This cupola was designed for the purpose of making soft iron for light castings. It only differs in construction from the ordinary type in the reservoir or tank placed in front, which may be attached to any cupola.

The cupola is set high, and the tank *A* is placed in front of it, with the cupola spout leading into it near the top. The molten iron is run from the cupola into the tank as fast as melted, and drawn from the tank-spout into the ladles as it may be required for pouring. The tank is made of boiler plate and lined with fire-clay or other refractory material, and is covered with an iron lid, lined likewise with same material. The spout and breast are made up the same as for an ordinary cupola. Before putting on the blast, the tank is filled with charcoal and closed with the cover; and as the iron melts, it is run into the

FIG. 35.

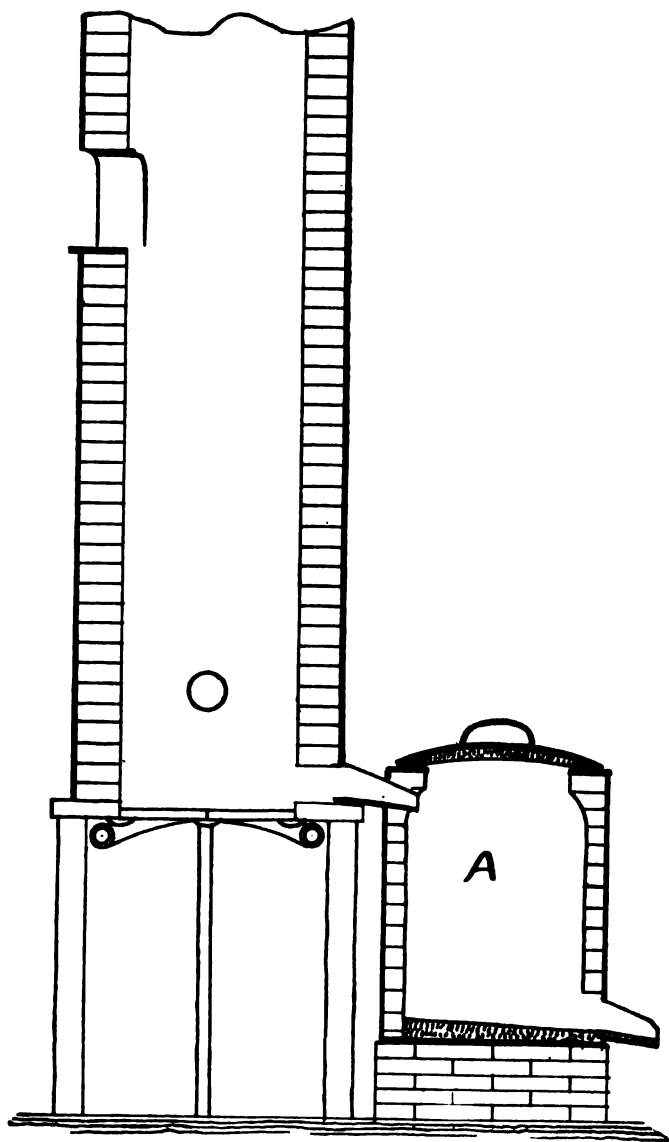

TANK OR RESERVOIR CUPOLA.

tank, where it is allowed to remain a sufficient length of time to be carbonized and softened by the charcoal.

These cupolas have been constructed in a number of different ways; the tank has been made of sufficient size to hold the entire heat of molten iron before pouring, so that the iron might be of an even grade throughout the heat and softened to a greater extent; and they have been riveted to the cupola casing and the lining continued from the cupola to the tank. In this latter case, the top is bolted or clamped to the tank and a tight joint made to prevent the escape of the blast, which has the same pressure in the tank as in the cupola.

The tank cupola produces a softer iron than the ordinary cupola, but there is considerable additional expense attached to it in keeping up the tank and supplying it with charcoal. Another objection is the change made in the shrinkage of the iron; that taken from the tank shrinks less than the same grade of iron when taken from the cupola, and when some parts of a machine or stove are made from the tank and other parts from the cupola, allowance must be made in the patterns for the difference in shrinkage.

It is claimed by some founders that soft iron can be produced by putting a quantity of charcoal on the sand bottom, and placing the shavings and wood for lighting the bed on top of the charcoal. In lighting up, the charcoal is not burned, but remains in the cupola during the heat and may be found in the dump. This is the case if the tuyeres are high and the front is closed before lighting up; but if the tuyeres are low or the front and tap-hole are not closed, the charcoal will be burned out in lighting up the bed, the same as the wood.

Tanks are, in England, used in connection with cupolas to some extent at the present time for mixing irons or to enable the founder to run a large casting or heat from a small cupola. The iron for an entire heat, requiring several hours to melt in a small cupola, is melted and run into the tank and drawn from the tank into the ladle at casting time. This makes a well-mixed and even grade of iron in all the castings and saves con-

siderable time in casting, as the molders are not obliged to wait for iron to melt, as is often the case.

MACKENZIE CUPOLA.

In Fig. 36 is shown a sectional elevation of the Mackenzie cupola, designed by Mr. Mackenzie, a practical foundryman. When this cupola was designed the only one in use was the common straight one with a limited number of very small tuyeres and low charging doors, and it melted very slowly. It was the custom in foundries at that time, to put on the blast at one or two o'clock and blow all the afternoon in melting a heat. Molders generally stopped molding when the blast went on and a great deal of time was lost in waiting for iron. To save this time and get a few hours' more work from each molder on casting days, Mr. Mackenzie conceived the idea of constructing a cupola that would melt a heat in two hours from the time the blast was put on until the bottom was dropped. He had discovered that the tuyeres in common use were too small to admit blast freely and evenly, and cupolas did not melt so well in the center as near the lining and tuyeres. To overcome this fault in the old cupola, and admit the blast to the stock evenly and freely, a belt tuyere was put in extending around the cupola, and to place the belt nearer to the center of the cupola at the tuyeres, the lining was contracted or boshed at this point. To avoid reducing the capacity for holding molten iron below the tuyeres, the lining just above the tuyeres was supported by an apron riveted to the cupola casing and the bosh made to overhang the bottom, leaving the cupola below the tuyeres of the same diameter as before boshing.

This cupola, when first introduced, was known as the two-hour cupola, and wrought a great revolution in melting and in foundry practice. Heats that had required half a day to melt were melted in two hours, the quantity of fuel consumed in melting was reduced, the number of molds put up by each molder increased, and the cost of producing castings greatly reduced.

Many of these cupolas are still in constant operation, and for

FIG. 36.

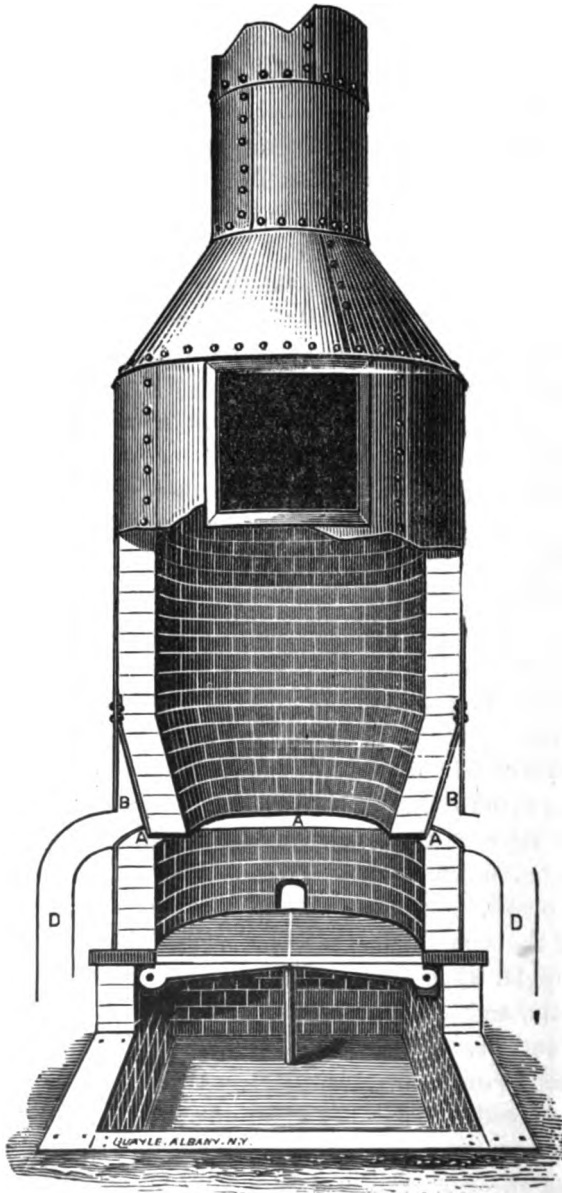

MACKENZIE CUPOLA.

short heats of one or two hours are probably the most economical melting ones now in use. In long heats the tendency of the cupola to bridge at the bosh is so great, that it melts slowly toward the end of a heat and is frequently difficult to dump, especially if the cupola is a small one.

We have had much experience in melting in these cupolas, and have found that slag and cinder adhere to the lining over

FIG. 37.

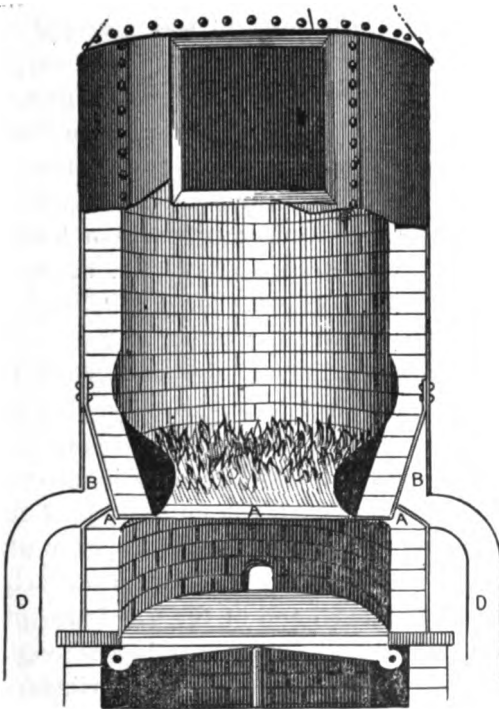

the tuyeres, and become very hard and difficult to remove, and if care be not taken to remove them after every heat it soon builds out, as shown in Fig. 37, which reduces the melting capacity very much, and increases the tendency of the cupola to bridge and hang up. The lining should be kept as near the shape shown in Fig. 36 as possible, and all building out

over the tuyeres and bellying out in the melting zone, as far as possible, prevented.

In the illustration (Fig. 36) is shown the cupola pit, commonly placed under cupolas when they are set very low for hand-ladle work. The outlet to the pit may be placed at the front, back or side of the cupola, as found most convenient for removing the dump.

DR. OTTO GMELIN'S CUPOLA.

The cupola shown in Fig. 38 was invented by Dr. Otto Gmelin, of Buda-Pesth, for smelting iron, copper, or other metals, and has during the last few years won ground in Austro-Hungary, and is now also being introduced in Germany.

The illustration hardly requires any further explanation, considering the simplicity of the principle on which the furnace is constructed. Two concentric cylinders of boiler plates with two annular spaces between them, closed at the bottom, and open at the top, are placed on a foundation ring of brickwork. Cold water enters the annular space at the bottom, and the warmed water flows off below the upper edge of the cylinders.

The interior of the inner boiler-plate cylinder is, says *Engineering*, made rough, and is covered with fire-clay. The circular space between the two cylinders is covered over by a cast-iron plate which lies loosely on the top of the two cylinders. Two circular grooves in the cast-iron top plate maintain the two cylinders at the correct distance from each other.

The outlet of the metal and of the slag takes place through tubular boiler-plate connections passing through the water space and attached to the inner and outer cylinders. The construction has lately been considerably simplified and strengthened by making the inner furnace cylinder of a welded tube, with tubes for air inlets welded on all in one piece.

The novelty of the above construction consists chiefly in the cooling of the smelting furnace by water without using an airtight water space. The inner cylinder can expand and contract without any resistance as the temperature in the furnace

FIG. 38.

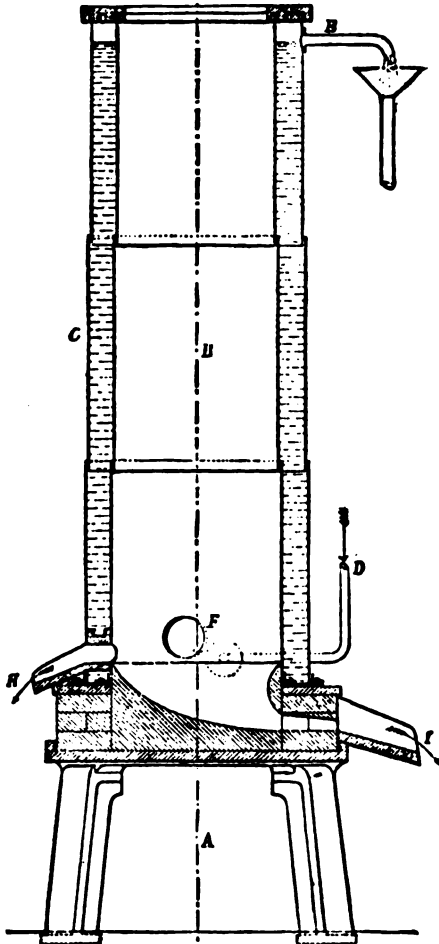

DR. OTTO GMELIN'S CUPOLA.

FIG. 39.

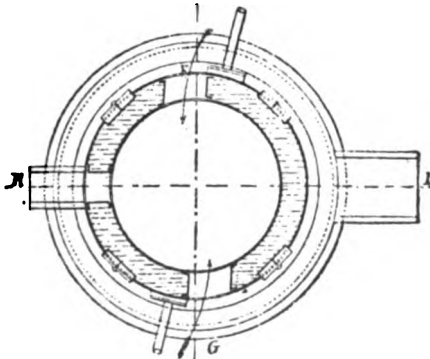

THE TOP PLATE.

changes, and the consequence is that repairs are hardly ever required. The first furnace built upon this principle has now been at work daily for the last $2\frac{1}{2}$ years without ever having required any repairs to the boiler plates of the cylinders. The smelting operations can therefore also be kept up for any length of time without interruption. The energetic cooling of the inner smelting cylinder, which takes place with this system of furnace, is also stated to afford advantages as regards the saving of fuel (equal to 6 to 8 per cent.) and the decrease of burnt metal, as well as the good and equal quality of the castings.

The above illustrations and description of Dr. Otto Gmelin's cupola are taken from a foreign engineering journal, and are here given to show what is being done in the way of protecting cupola linings with water.

This theory has been a hobby of a number of founders we have met, and it has often been tried in this country and in a variety of ways, with but limited success. In one instance we recall to mind, gas pipe was closely coiled around the cupola at the melting zone, and covered with daubing one or more inches thick, and water forced through the coil when the cupola was in blast.

In another, a tank constructed of boiler plate was placed around the inside of the cupola at the melting zone, and protected by daubing. In both of these experiments it was found difficult to keep the pipes and tank filled with water, as the heat was so intense that water was driven from them very rapidly after melting began, and in one of them the bottom had to be dropped for fear of collapse of the tank and caisson. But this objectionable feature may readily be overcome by making the tank large and the inlet and outlet ample for a supply of cold water, which was not the case in this instance.

The doctor appears to have solved this problem by extending the water space from the bottom to top of cupola, giving a larger body of water to be heated than in the tests referred to. But even when this is done the water space must be large and the supply admitted at the bottom abundant, or every drop of water will be forced from the water space by the heat.

The experiment referred to, while not perfectly satisfactory, so far as keeping the lining cool with water, was sufficiently so to convince the advocates of this theory in each case that nothing could be gained by protecting a lining in this way; for they found by cooling the lining at the melting zone the melting capacity of their cupola was reduced and more time was required to melt their heat and probably more fuel was consumed. While this cupola may be a success in foreign countries, where slow melting is done, it would hardly prove a success in this country with our present desire for rapid melting, and is not likely here to come into use. As for the saving of fuel and improved quality of iron, all new cupolas effect these results, and they require no further consideration.

PEVIE CUPOLA.

In Fig. 40 is seen the Pevie cupola, designed by Mr. Pevie, a practical foundryman of the State of Maine. The small cupolas, 18 to 24 inches, of this design are built square, with square corners in the lining, and larger ones are made oblong with square corners and 24 to 30 inches wide inside the lining, and any increase in the melting capacity of the cupola desired, is obtained by increasing the length of the cupola in place of increasing the diameter, as is done with the round cupolas.

Blast is supplied on two sides from an inner air chamber, through a vertical slot tuyere extending the full length of the sides of the cupola.

The object of Mr. Pevie in constructing a cupola upon this plan was to supply an equal amount of blast to all parts of the stock and to produce even melting. This theory was correct, for blast was certainly more evenly distributed to the stock than with the small round tuyere then commonly used, and we saw excellent melting done in cupolas of this construction in the foundry of Mr. Pevie, in a small town in Maine (the name of which is forgotten), which we visited some twenty years since. But in cupola construction an even distribution of blast is not the only matter of importance to be considered; for if it bridges

THE CUPOLA FURNACE.

FIG. 4C.

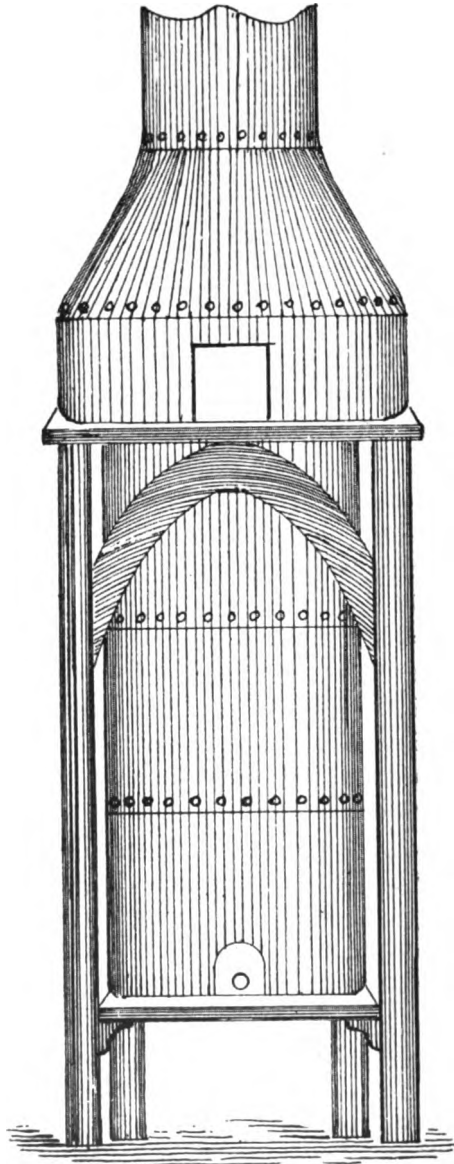

PEVRIE CUPOLA.

and clogs up, the blast cannot do its work, no matter how evenly it may be distributed by tuyeres or by the construction of a cupola, and the peculiar construction of this cupola made the tendency to bridge very great. It was only by careful management that it could in long heats be prevented from bridging, when the lining was kept in its original shape, and for this reason it never came into general use. We know of only three of them at the present time in operation, one at Smithville, N. J., and two at Corry, Pa., and the shape of the linings in these cupolas has been greatly altered from their original form.

STEWART'S CUPOLA.

In Fig. 41 is seen a sectional view of a cupola in use at the Stewart Iron Works, Glasgow, Scotland. This cupola, which is one of large diameter, is boshed to throw the blast more to the center of the stock and reduce the amount of fuel required for a bed. Blast is supplied from a belt air-chamber extending around the cupola, through a row of tuyeres passing horizontally through the lining and a second row placed above and between the tuyeres of the first row and pointing downwards, as shown in the illustration. The object of this second row of tuyeres is to increase the depth of the melting zone and increase the melting capacity of the cupola per hour. Attached to the top of the air-chamber at intervals of about two feet, is placed a vertical gas-pipe of two inches diameter, and from this pipe four branches of one-inch pipe lead into the cupola, about twelve inches apart. The object of these pipes is to supply a sufficient amount of oxygen to the cupola above the melting zone to consume the escaping unconsumed gas, namely carbonic oxide (CO), above the melting zone, and utilize it in heating and preparing the iron for melting before entering the zone. The cupola melts very rapidly, and is said to be the best melting one in Glasgow. But it is very doubtful if the one-inch gas-pipe tuyeres contribute anything towards the rapid melting, for it is absurd to suppose that one-inch openings placed twelve inches apart vertically and two or more feet

THE CUPOLA FURNACE.

FIG. 41.

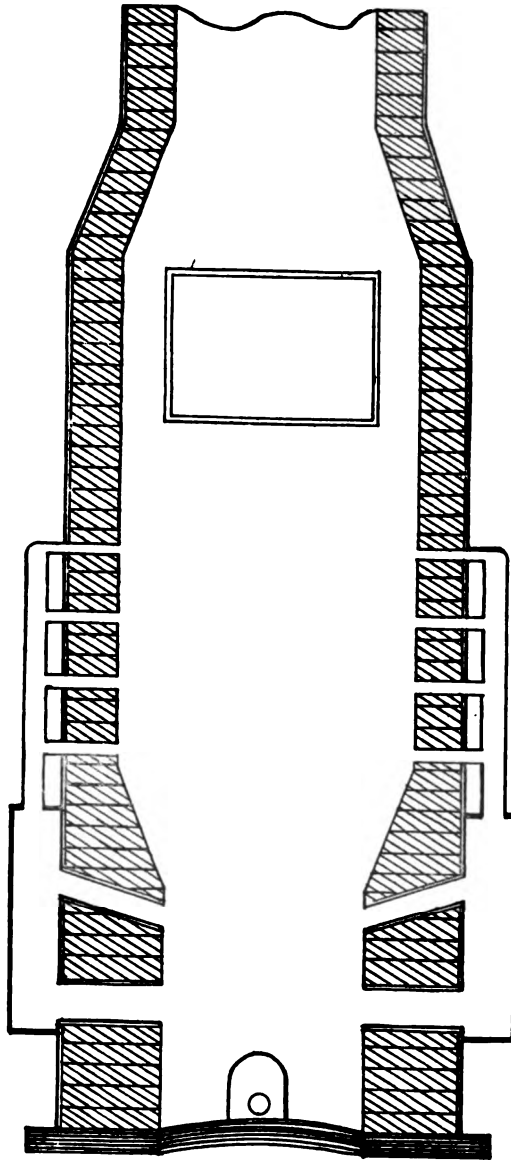

STEWART'S CUPOLA.

apart around the cupola, would supply a sufficient amount of oxygen to fill a large cupola to such an extent as to ignite escaping carbonic oxide in the center of the cupola. While they might supply oxygen for combustion of carbonic oxide near the lining, we do not think they would admit a sufficient amount to be of any practical value in melting, even if they admitted a volume of blast equal to their capacity when placed in the lining. This they do not do, for they are frequently clogged by fuel or iron, filled with slag from melting of the lining, and as a lining burns away the ends of the pipes are heated and frequently collapse at the ends, and it is almost impossible to keep them open during a heat or to open many of them after a heat is melted. The rapid melting in this cupola is probably due to the arrangement of the first and second rows of tuyeres and the shape given to the inside of the cupola, which is excellent for cupolas of large diameter.

THE GREINER PATENT ECONOMICAL CUPOLA.

In Fig. 42 is shown the Greiner cupola, for which the following claims are made:

In placing the Greiner Patent Economical Cupola before the foundrymen and steel manufacturers in this country, we have the advantage of the splendid results already obtained with this cupola in Europe, where more than three hundred are in daily use.

The adoption of the Greiner system of melting iron there has met with the most satisfactory results. In no case has the saving of fuel been less than twenty per cent., and in some instances it has reached forty and even fifty per cent.

The novelty of the invention consists in a judicious admission of blast into the upper zones of a cupola, whereby the combustible gases are consumed within the cupola and the heat utilized to pre-heat the descending charges, thereby effecting a saving in the fuel necessary to melt the iron when it reaches the melting zone.

Considerably more space was given to this cupola in the first

edition of this work, where it may be seen; but as we do not know of a single one of them in operation in this country, we devote the space to more important matter. The same princi-

FIG. 42.

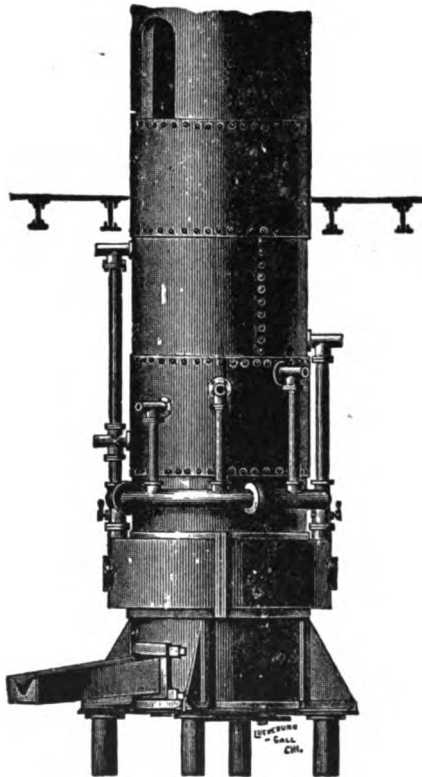

THE GREINER PATENT ECONOMICAL CUPOLA.

ple may be seen more fully illustrated in the sectional view of the Stewart Cupola (Fig. 41).

STEAM JET CUPOLAS.

The arrangement of pipes of the Greiner cupola recalls to mind the arrangement of pipes, a variety of which we have seen, for admitting steam jets at various points to cupolas for

the purpose of improving the melting or the quality of the iron. This mode of melting has been thoroughly tried in this country in years past and a number of patents have been taken out for it here and in Canada, none of which have ever come into general use, although great claims have been made for them both as to economy of fuel and improvement of quality of iron. The inventor of one of them, which we saw in operation, some twelve years ago, went so far as to claim he could from a cupola produce an iron having all the qualities of malleable iron. This device we found upon investigation to consist of putting a jet of steam into the cupola at the tuyeres with the blast, which only amounted to putting that amount of water into the cupola, which, so far as we could see, had no effect on the quality of iron, and certainly no malleable iron was produced in the heat we saw melted.

We made a series of experiments in melting in a cupola with steam with and without blast some twenty-five years ago. A detailed account of these experiments is not necessary, for they proved a complete failure so far as saving fuel, making hotter iron or improving the quality of the iron; although we were under the impression at the time that some improvements had been effected, these like many results obtained in experiments, were deceptive and due rather to careful management of the cupola than to any benefit derived from the steam. Since making these experiments we have met a number of men who have experimented in this direction, among them the late Thomas Glover, who, when foreman of the large foundry of Morris, Tasker & Co., made extensive experiments with steam in their large cupolas, using wet and super-heated steam, and putting it into the cupola at the tuyeres and above and below the melting zone. Mr. Glover kept an accurate record of these experiments, a copy of which he offered to furnish for this work, but the experiments were made years ago, and when he came to look for the record it could not be found. That the results of these experiments were not satisfactory is shown by the fact that Morris, Tasker & Co. did not continue

the use of steam in their cupolas, and when Mr. Glover engaged in business for himself, as the firm of Glover Bros., he did not apply steam to their cupolas.

From what we have observed in melting with wet and superheated steam we have concluded that the passing of steam into a cupola amounts only to the placing of a certain amount of water or moisture in it, and this may be accomplished in a more economical way than with steam. By placing a small water jet at each tuyere the water may be atomized and carried into the cupola with the blast, and by placing one or two gunny bags over the inlet of a blower, and keeping them wetted with water, moisture may be added to the blast and carried into the cupola. But probably the best way to accomplish this is to wet coke before charging. Years ago it was the common practice of founders to let their coke lie out in the weather, and in dry weather to wet it with a few buckets of water before charging, upon the theory that wet coke made hotter iron than dry. But since the discovery by some one that about one-third more coke is required to smelt iron in a blast furnace on a wet day when the atmosphere is full of moisture, than on a dry day, this theory has been abandoned by founders and coke carefully housed.

While this discovery may be correct in a blast furnace, which we very much doubt, thinking that a careful and prolonged test will demonstrate that the reverse is the case, and that more fuel is required on a dry day than a wet one. For a gas may be made from water having a sufficient number of heat-producing units to melt iron. This being the case, why should not a blast saturated with moisture produce a greater amount of heat than a dry one? But whether or not this theory be correct as regards a blast furnace, it is certainly not so in a cupola, for no founder ever thinks of placing more fuel in his cupola on a wet day than on a dry one, and always has hotter iron on a wet, murky or foggy day than on a dry clear one, with the same amount of fuel.

From our observation in the use of steam in a cupola, we

are of the opinion that, as good results may be obtained from steam generated in a cupola in any of the ways outlined as from steam generated in a boiler and conveyed to it by pipes, and that no great benefit can be derived from steam in either way.

COLLIAU CUPOLAS.

The Colliau Cupola was designed and manufactured by the late Victor Colliau, who spent much time and thought in the improvement of cupolas, and to whom is due the credit of the present fast and continuous melting in cupolas, at least in this country; for he was the first to introduce the double row of tuyeres for rapid melting, and the tapping of slag for continuous melting. The general outlines in construction of this cupola are shown in figs. 43 and 44, which are now manufactured by Mr. Colliau's former partners, Messrs. Bryam and Co. The only difference in general outline of construction between this cupola and his later design was in extending the belt air chamber from the bottom plate up to near the charging door for the purpose of heating the blast by heat escaping through the caisson. This arrangement and construction he designated a hot blast cupola, but it proved a hot blast in name only, and after a few of them had been placed in foundries and proved failures in heating the blast, this plan of construction was abandoned and his cupola constructed upon the plan shown in illustration. After the death of Mr. Colliau, his cupola business was entirely wound up, and the only Colliau cupolas now obtainable are those manufactured by other firms.

STANDARD COLLIAU CUPOLA FURNACE.

In the Figs. 43 and 44 are shown external and sectional views of the Colliau cupola as originally designed by Mr. Colliau and now manufactured by his former partners. The following short description is from their circular:

The Colliau is made in three distinct parts, so that parties desiring to make only a small outlay and at the same time secure the benefit arising from use of the Colliau may order

FIG. 43.

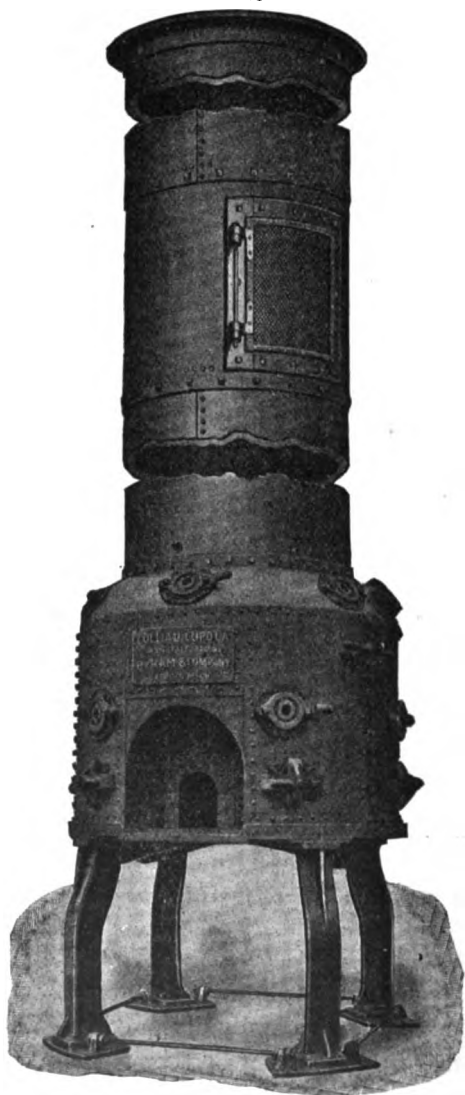

COLLIAU CUPOLA.

only the lower part with air chamber tuyeres and melting zone, which constitute the essential parts and may be used with any suitable "stack" and "foundation."

The lower portion of the Colliau is composed of two sheet-steel shells, the inner shell being made very heavy and of the same size as the stack proper. The outer shell encircles the inner one and is made air-tight, forming the air chamber, which varies in size according to size of furnace. In the outer shell are arranged two doors or shutters held in position by tap bolts, also made air-tight, which may be removed and be again replaced after cleaning, should any coke or slag accumulate in the air chamber.

"Besides this," say the manufacturers, "we place a hand hole plate in the outer shell of air chamber directly under each lower tuyere, held in position by crab and bolt. Our air chamber is not fastened to the bottom plate, but is separate and distinct, and is air-tight in itself.

"Opposite each tuyere also is a sliding air-tight gate with peep hole, and in the beveled top is furnished a brass nipple to connect hose from the blast meter into the air chamber.

"Our present tuyeres are of the latest and most approved patterns, so arranged that the blast is distributed over the entire area of the combustion chamber, and are constructed in such form that the melted iron in its downward course cannot pass through them into the air chamber. If desired, these lower tuyeres can be made adjustable in height.

"The Bottom Plate of each furnace is made in four (4) pieces, with joint over each leg, at which point it is reinforced by a steel plate. This arrangement permits of the necessary expansion and contraction without the possibility of cracking.

"Each furnace is provided with a metal alarm and trap with fusible disc.

"The furnace, as a whole, is simple in its construction. There is no complicated machinery or parts to get out of order, and consequently does not require any more attention or repairs than a common cupola.

“In large shops, and where a large number of hands are employed, the most important factor in melting iron is the rapidity with which it can be done.

FIG. 44.

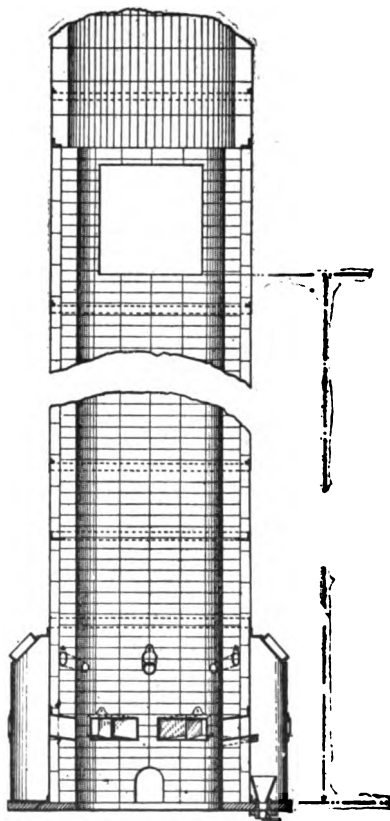

“The records of ‘the Colliau’ in this respect have never been excelled.

“The Cupola can be operated by unskilled workmen, if instructions are followed.”

THE NEWTON CUPOLA.

The Newten Cupola, fig. 45, while of modern design and

FIG. 45.

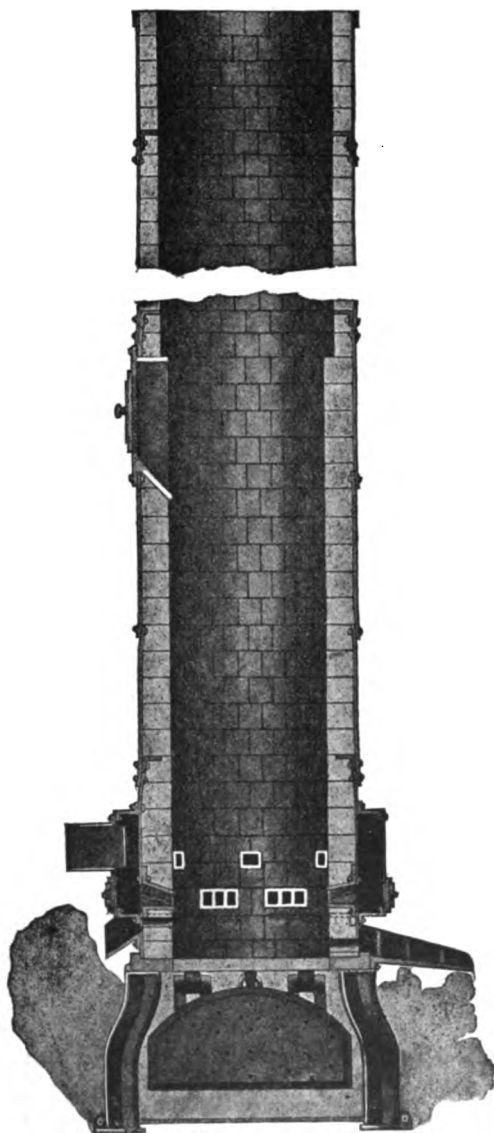

THE NEWTEN CUPOLA.

fully up-to-date, reminds one of the days of the common straight plain cupola, when iron was supposed to be melted in a cupola and drawn from the tap-hole and not from the wind box.

Mr. Newton, the designer of this cupola, evidently understood that melting is done inside of a cupola and not on the outside, for he has not devoted all his attention to the designing and construction of a wind box with elaborate air-tight hand-holes and openings for removing iron and slag from it, nor to the making of a cupola as big as a blast furnace or to resemble one by nonsensical outside attachments. But he has given to the outside a neat cupola-like appearance, while retaining all the modern inside improvements in construction, arrangement of tuyeres, safety tuyere, slag-hole, etc.

The following is part of what the manufacturers have to say about it:

“The Tuyere System, which is patented, is in accord with the best practical and theoretical modern cupola practice.

“The combined tuyere area is the important consideration, and the exact proportion which the areas of tuyeres, blast pipe and air chamber bear to the size of the furnace and the blower, has been carefully adjusted to obtain the best melting speed and the most economical fuel results.

“*The Main Tuyeres* are of the expanded type, both inlet and outlet being of ample area to insure the transmission of sufficient air to the furnace. The increase in the area of the greatest portion of the tuyeres as they approach the fuel secures a blast of large volume and of moderate pressure nearest the iron, and the wide tuyeres afford nearly a continuous blast opening around the furnace walls. By these means ample blast area is assured, even if a portion of the tuyere area is stopped by pieces of coke or other obstructions.

“The lower tuyeres are adjustable vertically, through several inches, to suit either a deep or a shallow bed of fuel. This adapts the furnace to either coke or coal, or to any change in the inside diameter of the furnace, to suit different classes of work.

"One tuyere has a low spout connected with a soft metal plug; this is burned out and gives warning if the molten iron should rise too high.

"The upper tuyeres are fitted with dampers enabling them to be closed if desired; the main tuyeres having ample area for the required capacity.

"Special attention has been given to methods of getting the blast to the fuel in the most direct and efficient manner.

"The entire body of the air chamber—bottom, top and sides—is made of plate steel, flanged, riveted and caulked, insuring an air-tight construction.

"The blast enters the air chamber through a single inlet, which branches to right and left, giving a tangential motion to the blast in both directions.

"The bottom of the air chamber is raised several inches above the bottom plate to afford free inspection of the bottom of the shell at all times, it being at this point that cupola shells most frequently fail through rust.

"The bottom plate is very thick, and is heavily ribbed; a flange extending around the entire shell.

"Bottom doors are of the hinged-drop type, with perforated plate and four heavy ribs on each door. On large cupolas there is provision for the attachment of levers for lifting doors into place.

"A slag opening is located below the lower tuyeres, its height being adjustable to suit conditions. It is fitted with a suitable slag spout. By using the slag hole, the cupola can be kept from clogging, and continuous melting for a long period will result.

"The charging door is extra large. The frame has a heavy iron slide at its base, protecting the lining. The charging doors may be either of the plate type for brick or mud lining, or of the wire screen type, the former being used unless otherwise ordered. Two charging door openings or frames are provided on all cupolas left larger than 72 inches.

"Our No. 30 Cupola is often sold as a test cupola, for work

at technical schools, or in large plants for testing quality of iron. It can be mounted either on trunnions or on columns in the regular way.

“ In this cupola but two large tuyeres are used, and the air is carried direct to the tuyeres from a branched blast pipe, the standard air chamber being omitted.

PAXSON CALLIAU CUPOLA.

In figs. 46, 47 are seen external and sectional views of the Paxson Calliau cupola, illustrating the two zones of melting as designed by Mr. Calliau, but changed in some important details in construction in this cupola, to bring it fully up to date as a latest improved cupola. The lower tuyeres are rectangular and flared, and the upper ones are oval. They are staggered so that there is very little dead space, the blast reaching every part where it is wanted, being distributed evenly. Therefore, the lining is not affected by the action of the blast to the extent that would be expected where upper and lower tuyeres are used and two zones of melting are at work. There are six lower and six upper tuyeres which tend downward. This makes better combustion and prevents molten iron from entering the wind chamber through the tuyeres. Through the greater portion of the heat there is very little or no flame shown at charging doors, showing that the upper tuyeres provide sufficient oxygen where it is wanted below the stock in the cupola where the heat is most severe.

The tuyeres are rendered readily adjustable by a novel and simple arrangement. The tuyere boxes are made double or in two sections when desired, and when it is deemed advisable to lower the tuyeres, brick are removed from the lower section and placed in the upper one. In this way the tuyeres may be raised or lowered in a few minutes without disturbing the lining outside of the tuyeres.

A low safety tuyere and trap with soft metal plug is provided, which discharges any overflow through the bottom plate. Therefore should the iron rise unexpectedly there is no

FIG. 46.

FIG. 47.

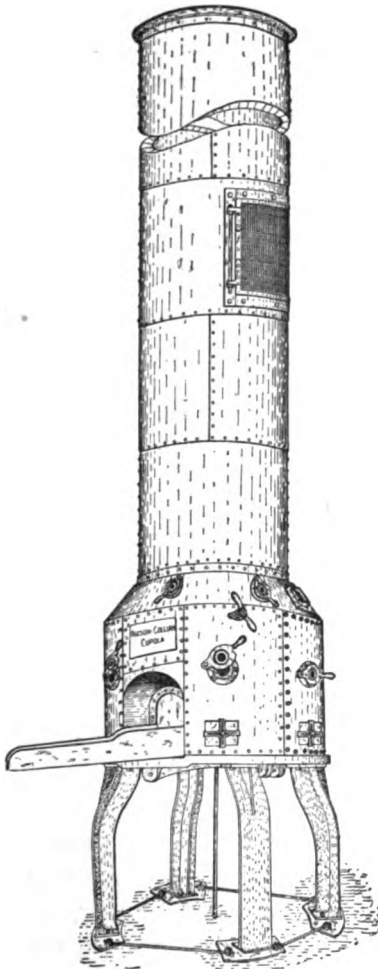

PAXSON HOT BLAST CALLIAU CUPOLA.

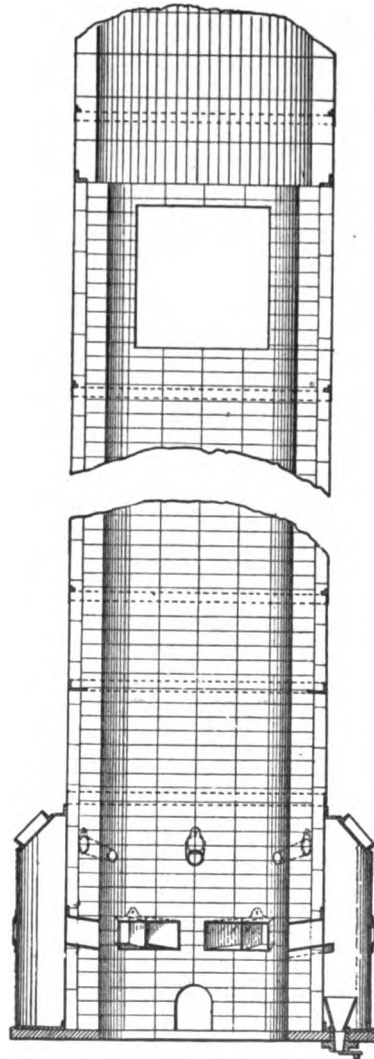

SECTION OF PAXSON HOT BLAST CALLIAU CUPOLA.

possibility of it getting into the wind chamber through the tuyeres and injuring the chamber, as the cornucopia shaped

trap shown in fig. 47 receives it and permits it to flow at once out of the chamber.

The upper tuyeres can be opened or closed by the turn of a crank that is arranged for opening and closing them, and the cupola made a single tuyere cupola for small heats or a double tuyere for a large one when fast melting is desired.

A slag-hole spout is placed in the back so the slag can be drawn off at will. It is this fact that makes this cupola a continuous melter.

The cupola is made of any size desired, from 12-inch inside diameter up to any capacity desired, and is constructed in three sections or distinct parts, viz.: No. 1, bottom plate and supports; No. 2, portion of base 3 to 5 feet high, according to size of cupola, with air chamber, upper and lower tuyeres, tap trough, slag spout and blast gauge; No. 3, casing, charging doors and stack. The cupola may be ordered complete or in parts, thus enabling parties desiring to make only a small outlay to obtain a fully up-to-date cupola by ordering only the essential parts of it and constructing the remainder from material at hand.

The legs or supports are made any length desired from 2 to 7 feet, so that the cupola may be placed at a height suitable for ladles used in pouring or that a car may be placed under cupola for receiving the dump and removing it to the yard or tumbling bands, where it may be quickly cooled and milled. The drop doors, when desired, are fitted with counter-balance weights to facilitate raising them into place.

In Fig. 48 is seen the indestructible wire screen charging door with which this cupola is fitted. It requires no lining and does not warp or crack. As before stated in this work, a charging door has nothing to do with a cupola melting, and is only of use to give draught for lighting up and prevent sparks or pieces of fuel being thrown upon the scaffold toward the latter end of a heat, and this door answers every purpose. It is hung on the outside of the cupola and does not come in contact with the heat to the same extent as the lined or iron door, is lighter and easy to swing and lasts longer than either of the

others. This door, although called indestructible, does not last forever, and its frame is constructed in such a way that the wire screen when destroyed by slow corrosion may be removed and replaced with a new one in a very short time.

FIG. 48.

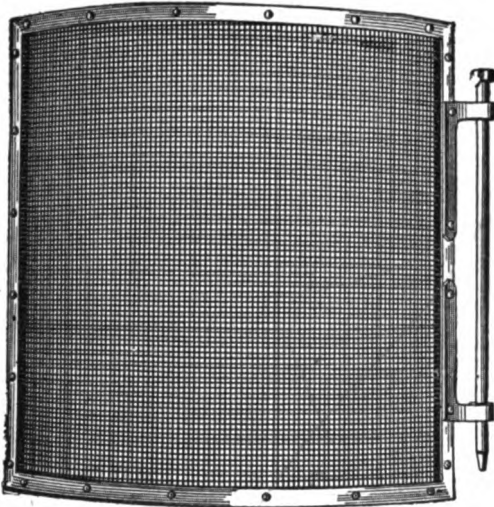

Small cupolas of this construction are made especially for the use of technical schools and colleges, and also for use in large foundries for testing brands of pig iron, and in interior towns for melting small quantities of iron.

THE WHITING CUPOLA.

In Fig. 49 is seen the Whiting patented cupola, designed by Mr. Whiting, a practical foundryman, of which the following description is given by him :

The universal satisfaction given by the Whiting cupola is largely due to the patented arrangement and construction of the tuyere system, which is so designed as to distribute the blast most efficiently, carrying it to those portions of the cupola where it will do the most good, under a reduced pressure, and through an increased area.

There are two rows of tuyeres. The lower ones are arranged to form an annular air inlet, distributing the blast continuously around the entire circumference of the cupola.

This system of tuyeres is also arranged to be adjusted vertically. This provides for adjustment to the class of work, kind of fuel, and changes in the inside diameter of the cupola.

FIG. 49.

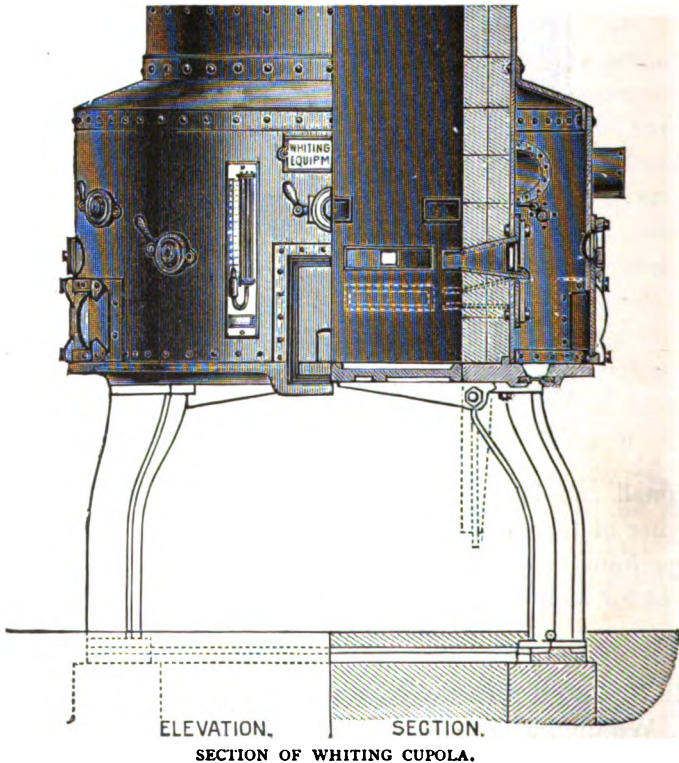

These tuyeres are flaring in shape and admit the blast through a small area which is expanded into a large horizontal opening on the inside of the cupola, thus permitting the air to reach the fuel through an area nearly double that through which it enters the tuyeres—admitting the same volume of blast, but softening its force.

There is an upper row of tuyeres of similar construction to supply sufficient air to utilize to the fullest extent the escaping carbon gas. These tuyeres are of great service in melting and in large heats—for small heats they may be closed by means of our improved tuyere dampers.

Fig. 49 represents the latest type of the Whiting patent cupola. A half vertical section is represented, showing the arrangement of the improved tuyeres and the method of adjusting them vertically. These tuyeres are arranged on slides and can be placed at various heights, as shown by dotted lines.

It sometimes happens that the operator finds the cupola too large for his needs. When this is the case, a thicker lining can be used and the tuyeres adjusted accordingly, and for small heats the proper ratio of coke to iron can be maintained; otherwise a large cupola running small heats will decrease this ratio materially, adding considerably to the cost of castings.

A change can be made from coke to coal fuel, and the bed made of suitable depth, by simply adjusting these tuyeres.

No other cupola has this device. It practically gives the operator two cupolas in one.

This figure also shows the safety alarm attachment, side plates, improved blast meter and upper tuyere dampers, etc.

Every cupola is provided with the foregoing improvements, together with foundation plate, bottom plate and doors, columns (three to five feet long), slag and tapping spouts and frames, peep holes with fittings, patent tuyeres and charging doors and frames. All fitted ready to erect.

JUMBO CUPOLA.

In the accompanying illustration, Fig. 50, is shown a sectional elevation of the large cupola known as Jumbo, in use in the foundry at Abendroth Bros., Port Chester, N. Y., to melt iron for stove plate, sinks, plumbers' fittings, soil pipe and other light castings, all requiring very hot fluid iron. The cupola, which was constructed for the purpose of melting all the iron required for their large foundry in one cupola, is of the following dimen-

sions: diameter of shell at bottom to height of 24 inches, 7 feet 6 inches; diameter in body of cupola, 9 feet; taper from large to small diameter, 5 feet 6 inches long; diameter of stack, 6 feet; taper from cupola to stack, 6 feet long; height from bottom plate to bottom of taper to stack, 20 feet; height to bottom of charging doors, 18 feet; two charging doors placed in cupola on opposite sides. Wind box inside the shell extending around the cupola, 5 feet 6 inches by 9 inches wide. Height of tuyeres, first row, 24 inches; second row, 36 inches; third row, 48 inches. Size of tuyeres, first row, 8 × 5 inches; second row, 6 × 4 inches; third row, 2 × 2 inches. Number of tuyeres in each row, 8; total number of tuyeres, 24. Slag hole, 17 inches above iron bottom, 11 inches above sand bottom. Two tap holes. Lining, 18 inches thick; over air belt, 9 inches. Diameter of cupola at bottom, inside the lining, 4 feet 6 inches. Diameter above taper, 6 feet. Cupola supplied with blast by No. 6 Baker blower.

It is charged as indicated in the table as follows:

DIFFERENT STYLES OF CUPOLAS.

Date, August 17, 1894. No., Jumbo. Cupola, No. 3.	Pounds coal.	Pounds coke.	No. 1.		No. 2X.		No. 2X.		No. 2X.	Sprues and scrap.	Pounds at each charge and total.	No. 2 Foundry Pioneer.	Remarks.
			Time.	Oz.	Time.	Oz.	Time.	Oz.					
Charge.....	2,100	900	2,500	2,500	1,500	1,500	1,500	1,500	4,000	12,000			Recorded by
Added	125	600	2,000	2,000	1,000	1,000	1,000	1,000	3,000	9,000			
Added	125	600	2,000	2,000	1,000	1,000	1,000	1,000	3,000	9,000			
Added	125	600	2,000	2,000	1,000	1,000	1,000	1,000	3,000	9,000			
Added	125	600	2,000	2,000	1,000	1,000	1,000	1,000	3,000	9,000			
Added	125	600	2,000	2,000	1,000	1,000	1,000	1,000	3,000	9,000			
Added	125	600	2,000	2,000	1,000	1,000	1,000	1,000	3,000	9,000			
Added	200	700	2,000	2,000	1,000	1,000	1,000	1,000	3,000	9,000			
Added	300	800	2,000	2,000	2,000	3,000	9,000	1,000		
Added	300	800	2,000	2,000	2,000	3,000	9,000	1,000		
Added	100	500	2,000	2,000	2,000	3,000	9,000	1,000		
Added	500	2,000	2,000	1,000	1,000	1,000	1,000	3,000	9,000		
Added	150	800	800	400	400	400	400	1,100	3,500		
Pounds of each	4,175	9,350	29,300	21,300	18,900	14,900	14,900	14,900	44,100	132,500	4,000		
Blast put on	12.30												
Iron flowed.....	12.38												
Pressure of blast in ounces.													
Blast to iron	M. 8	Time.	Time.	Time.	Time.	Time.	Time.	Time.	Time.	Time.	Time.	Time.	Time.
Dropped bottom	5-15	1.00	3.00	4.00	4.30	4.50
Blast to drop of bottom.	H. M. 4-53	Oz.	Oz.	Oz.	Oz.	Oz.	Oz.	Oz.	Oz.	Oz.	Oz.	Oz.	Oz.
		14	16	17	14	12
													1000 pounds iron over.

Three hundred and fifty pounds of limestone are placed on each charge of iron, except the last charge, and the slag hole opened after the blast has been on about three-quarters of an hour and permitted to remain open during the rest of the heat.

FIG. 50.

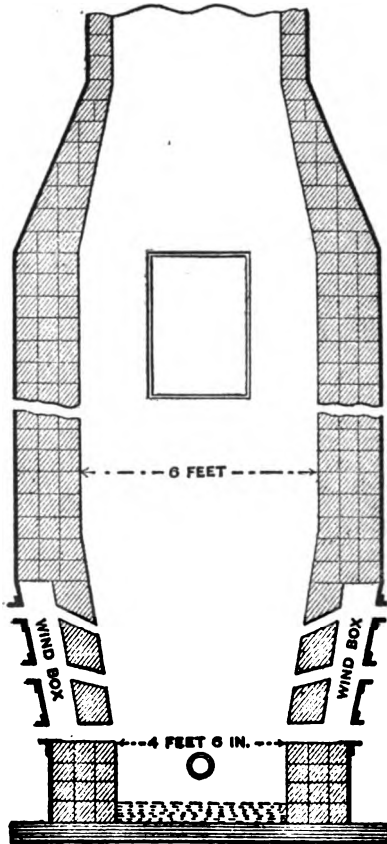

JUMBO CUPOLA.

The sprues, gates and foundry scrap are not milled before charging, and the large amount of limestone placed on each charge is required to liquefy the quantity of sand charged into the cupola on the scrap, and prevent clogging and bridging of

the cupola. Sixty tons of iron have been melted in this cupola in four hours from the time the blast was put on until the bottom was dropped.

THE CRANDALL IMPROVED CUPOLA WITH JOHNSON PATENT CENTER
BLAST TUYERE.

In Fig. 51 is shown the above-named cupola and tuyere. The cupola is designed with a view of getting a more efficient action of the blast than is possible to attain with the methods now in general use, and the manufacturers make the following claims for it: The experiments made in this new de-

FIG. 51.

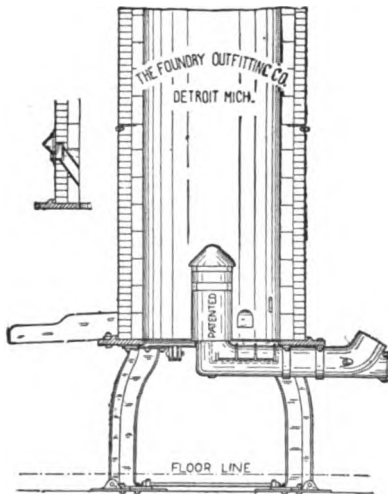

THE CRANDALL IMPROVED CUPOLA WITH JOHNSON
PATENT CENTER BLAST TUYERE.

parture have finally led to a very simple and durable construction, which we place before the foundrymen and request that they make a thorough investigation of it. It is a well-known fact that the matter of forcing blast to the center of a cupola and obtaining a complete combustion of fuel at that point, has been to many a puzzle, and various means have been

tried to accomplish this end. But it has been found in all cases, that a large portion of the blast when taken in at a high pressure through outside tuyeres, in striking the fuel is forced back against the brick lining, cutting it out very rapidly just above the tuyeres and then escaping up along the brick wall, doing no good, thereby requiring a greater volume of blast to melt the same amount of iron than is used when the blast is taken in at the center of the cupola. In the illustration (Fig. 51) is clearly shown the general arrangement.

The air, instead of being forced into the cupola furnace from the outside, is applied from the inside by means of a center blast tuyere attached to the under side of the bottom plate. This tuyere terminates at about the same height as outside tuyeres, and a continuous annular opening is formed for the blast by putting on a loose section of pipe and spacing it apart by means of pins that can be varied in height, so as to get any desired opening. On top of this loose section a cap is set; also spaced apart from it by means of pins, so that a second opening is formed for the blast to enter, and by taking in more air at this point the carbonic oxide, which would otherwise go to waste, is changed into carbonic acid gas, forming the whole interior into a melting zone, insuring complete combustion. Both the loose pipe section and the cap can be removed to have the lining of them repaired. The horizontal part of the center blast pipe has an opening at the elbow which enables it to be cleaned out, in case any obstructions should fall through the tuyere opening above. The drop doors close over this tuyere and can be opened without in any way deranging it. No belt air-chamber is required, as the tuyere may be connected direct to the main blast pipe; but in cases where such air-chambers already exist, the center blast tuyere may be attached to them without in any way disarranging the blast pipe. We would draw special attention to the fact that but little expense need be incurred in making this change outside of the price charged for the center blast tuyere and piping.

Claims are made as follows :

- 1st. A saving in brick lining.
- 2d. A saving in fuel.
- 3d. More rapid melting with less volume of blast.
- 4th. A more uniform temperature of iron than can be attained by the outside tuyere.

Note.—A letter sent to the manufacturer of this cupola in regard to its present range of usefulness failed to bring any reply, and it has probably been consigned to the fate predicted for the bottom tuyere in the first edition of this work, for we do not know of a single one of these cupolas being in use at the present time.

BLAKENEY CUPOLA.

In Fig. 52 is seen a sectional view of the Blakeney cupola furnace, the following history and description of which are furnished by The M. Steel Co., Springfield, Ohio.

By the Blakeney cupola furnace, the air is so distributed or projected into the furnace as to produce a uniform heat, giving the iron a uniform strength for all kinds of castings, The features peculiar to it are as follows:

The introduction of a combination of curved tuyeres or chutes placed upon the wall or lining of the cupola, and forming a part of the wall, a proper distance from the bottom, and nearly surrounding the inner and outer sides of the wall. The tuyeres are made of cast-iron and in sections for convenience of handling. A blank space is left in the rear of the cupola two feet wide, through which the slag is blown, if required.

A chamber or base extending around the cupola and enclosing the space in which the air is conducted to the tuyeres. The bottom of this chamber, made irregular in form, hollows at suitable intervals to allow the metal to flow to the escape openings, in case it overflows through the tuyeres. The openings are closed with fusible plugs of lead or other material, to be melted out by the molten metal.

The blast is conducted to this cupola through one pipe, and striking the blank space sidewise in rear of chamber, passes all

around through the curved tuyers into the center of the furnace, the blast striking into the cupola every seven-eighths of an inch horizontal, and $3\frac{3}{4}$ inches perpendicular, or according to diameter of cupola.

As a producer of a uniform grade of iron for the purpose of casting car-wheels, it is just what is needed for the different grades of iron to prevent chill cracking.

This cupola, with its many superior advantages, has also rows of shelves bolted to the shell four feet apart up to the

FIG. 52.

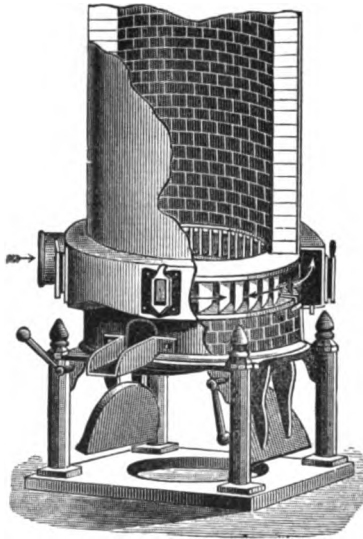

SECTIONAL VIEW OF BLAKENEY CUPOLA FURNACE.

top of the charging door, so that it will not be necessary to tear out any of the lining except that which is burned out. These cupolas have run eighteen months with heavy heats without being relined.

To prevent them being carried out of the stack, it is only necessary to provide sufficient room in the stack for the blast to expand, after escaping from the cupola, and lose its lifting force, when the sparks will fall back in the cupola and be con-

sumed. This may be done by constructing the stack casing of the same diameter as the cupola casing, and lining it with a thin lining of four-inch fire-brick supported by angle iron, so that the cupola lining may be removed or repaired without disturbing the stack lining. Cupolas constructed in this way, when the stack is of proper height, do not throw out sparks. When it is not desirable to have a very high stack, the enlarged stack shown in Fig. 57 may be used. The first cost of a stack of this kind is a little greater than that of a contracted one, but when properly constructed and lined, will last the life of a cupola. In fact we never knew one, if properly lined when constructed, requiring to be relined or repaired, and the saving effected by preventing damage to roofs, lumber, flasks, etc., from sparks will soon pay for the extra cost of construction. The objection usually made by foundrymen to large stacks is that they do not give sufficient draught for lighting up. This may be the case when the top of the stack is only a few feet above the charging door, but when given a proper height for arresting sparks there is always sufficient draught for lighting up. There are many cupolas constructed upon this plan in use at the present time, and they give better satisfaction than those with contracted stack.

CUPOLA ON WHEELS.

Fig. 53 illustrates a Paxson truck and track cupola constructed and used in melting iron for making joints in connecting the ends of rails for trolley roads. This cupola which is constructed upon a steel frame was first placed upon ordinary truck or wagon wheels as seen in the illustration, and moved from place to place by horses, but later on was mounted upon car wheels and moved upon the tracks by trolley power. The cupola, which is capable of melting about two tons per hour is an ordinary straight cupola with deep bottom and is supplied with blast from blower, seen on frame, by electric motor, getting its power from overhead trolley wire by means of a wire attached to a pole for hooking it over the trolley wire.

The cupola has no charging door or stack, fuel and iron being thrown in at the top. The V-shaped hood on top is for the purpose of throwing escaping heat to the sides and protecting the trolley wire seen over it. This cupola is of no use

FIG. 53.

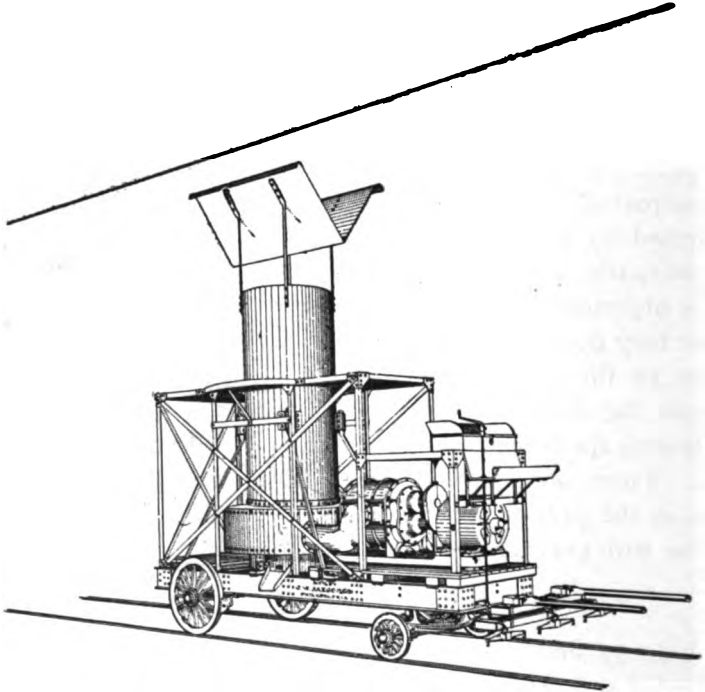

PAXON TRUCK AND TRACK CUPOLA.

in a foundry, but may be employed for a variety of outside work where molten iron can be used to advantage if obtainable.

These various cupolas are illustrated and described, not that we endorse all that is claimed for them, but to give our readers some idea of what has been done in design and construction, and what kinds may at the present time be obtained from cupola manufacturers. We have by no means exhausted the

different varieties, but have probably given sufficient examples to indicate the direction in which inventive genius has gone, as well as the objectionable points in construction which it has been their aim to overcome, and incidentally to illustrate the follies of would-be inventors whose aim appears to have been more in the line of getting something upon which to talk in selling their inventions than to improve a cupola. It is our experience that the plainer and simpler a cupola is constructed the better for practical melting. The old fashioned straight cupola is still in use and probably will be in use when many of the fancy-shaped and scientifically designed cupolas have gone.

The Adjustable tuyere is a comparatively new fake in cupola construction, and may be a good thing to talk about when selling a cupola, but they are of but little value in practice. For to raise or lower a tuyere it is necessary to cut away a certain amount of lining and replace it with new lining material, considerable time and labor is required to do this in a numerous tuyered cupola, and the molders must be laid off for a day or the work done on Sunday, so that considerable expense is incurred in adjusting a set of tuyeres. And the idea of adjusting tuyeres every day or two to suit size of heat is therefore impracticable.

We advise saving bad material and fuel by placing tuyeres low and running a continuous stream or as near a continuous stream as the work will admit of from the cupola. This system is being adopted by all the modern founders, and it is only the old-timers that tell of large taps made from their cupola.

WHAT IS NEW IN THE CUPOLA AND FURNACE LINE.

While looking around to see what was new in the cupola line we dropped into Paxson's and were shown a few things that while not exactly new, having been pretty thoroughly tried, might be of interest to our readers. Among them was Moor's patent cupola breast and runner, and mica schist lining, both of which promise to come into general use in the near future.

MOOR'S PATENT CUPOLA BREAST AND RUNNER.

The breast and spout which are shown in Fig. 54 are made of the same material as a plumbago crucible for melting steel or brass, or of fire clay, and baked in an oven the same as crucibles and fire brick. This breast and spout are designed to replace the common loam and clay breast and spout made up every heat and save material and labor in making them up. The illustration represents one cupola outfit. *a*, front and side view of breast; *b*, the stopper; *c*, the ring or thimble; *d*, the runner. The runner is made to order to fit the cupola spout,

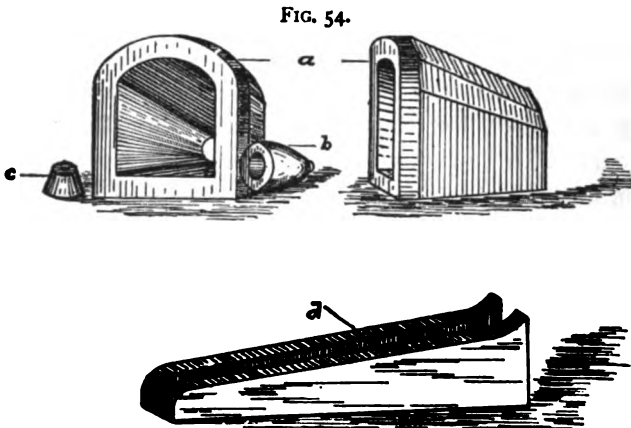

MOOR'S PATENT CUPOLA BREAST AND RUNNER.

the iron running over it to the ladle. It will last for three or four years with care. Runners are also made for slag spouts or in fact any spout where iron, steel or brass is run. It saves the clay or loam to make and mend it and the time in doing so. The breast will not only do away with the old clay or loam breast, but relieves the foreman of much responsibility. It should last six to eight months. The breasts are kept in stock and may be readily fitted to any cupola. With this breast and spout always in place, it is only necessary to make the sand bottom up to suit the tap hole and much material and labor are saved. The size of tap hole may be regulated by use of thimble or

ring *c*, or by placing a bod in the hole and making an opening through it of any desired size with a tap bar. These are the claims made for this breast and spout.

MICA SCHIST LINING.

Mica schist or fire stone, as it is sometimes called, is a soft rock that has been used for some time in lining steel converters and furnaces, and is now coming into use for cupola linings. This material is a soft rock that may be readily broken, and crumbles easily when handled, and can not be cut into shape for lining before shipment. It is therefore used in its natural state as it comes from the mines and fitted to the cupola as the lining is laid up. The small pieces or crumbs that are broken off in handling and fitting the lining are mashed up and mixed with a little fire clay; this makes a fire mortar that stands the heat equally as well as the solid rock, and when heated cements the entire lining into a solid mass that glazes and does not spall off and fall out so easily as fire brick.

At several foundries where this lining was being used we were informed that it was giving excellent results, and required less daubing and repair than fire brick. At one large foundry where a lining of this material had only recently been put in we were told that the lining material for their cupola had cost less than one-fourth the cost of fire brick for the same cupola; and while the cost of putting it in was a little greater, the lining when in had cost less than one-half that of fire brick, and in the few heats they had melted with it, it had not been cut out to so great an extent as with brick.

When putting in a lining of this material all backing or filling put in with fire brick should be removed and the lining made as thick as possible, for the thicker it is the more readily and quickly it may be laid up, and a backing is not required with it.

There are several other native lining materials in the market, such as ganister and mica soap-stone, that may be used to advantage when cost of transportation is not too great.

COMMON RED BRICK LINING.

The question of lining with common red brick bobs up every once in a while as something new, cheap and economical.

We have seen many cupolas lined with this material in days when fire brick were not so cheap or easily obtainable as at the present time. The softer brick were generally selected, and they were set on end with the edges to the fire, and two thicknesses of them were generally put in.

These linings answered the purpose very well, for the small heats commonly melted in those days, but with the heats melted in many cupolas at the present time it is doubtful if they would last through one heat; and even when heats are light they are a more costly lining in the long run than the more expensive fire brick or other material, for they require to be replaced very frequently at the melting zone, which necessitates taking a day or having the melter and helper work on Sunday, and this in time costs more than good lining material.

Use only the best of lining material, and the best of daubing material for keeping it up, and you will reduce cost of melting more than by using cheap material.

CHAPTER XVIII.

HOT BLAST CUPOLAS.

A NUMBER of plans have in this country been at different periods devised for utilizing the heat escaping from the top of a cupola when in blast, for heating the blast before entering the cupola at the tuyeres. The best arranged cupolas of this kind that we have seen are those shown in Fig. 55. This pair of cupolas were constructed at Albany, N. Y., by the firm of Jagger, Treadwell & Perry. With a view of saving fuel and improving the quality of iron for light work, the two cupolas *DD*, of thirty and forty-five inches diameter, respectively, inside the lining, and eight feet high, were constructed of boiler plate; the top and bottom plates between which the cupolas were placed were supported by four iron columns, and on the top plate were fitted the brick arches *BB*, which connected the cupolas with the brick ovens *EE*. In the rear of each cupola, between the ovens, was placed the high stack *A*. Each oven was filled with cast-iron pipe *CC*, through which the blast passed before entering the cupolas. When in blast, the escaping heat from the cupolas passed downward through the ovens as indicated by the arrows, and entered the stack *A* from the bottom of the ovens. The pipes were by the escaping heat from the cupolas heated to a red heat, and the blast in passing through these coils of pipe was heated to a sufficient degree to melt lead before entering the cupolas. This plan was a success so far as heating the blast was concerned, but the blast could not be heated up to the above degree until the cupolas had been in blast for some time. Hence very little fuel was saved, for no economy in fuel could be effected until the blast was heated, and the cupolas had to be fully charged with fuel for the first

THE CUPOLA FURNACE.

FIG. 55.

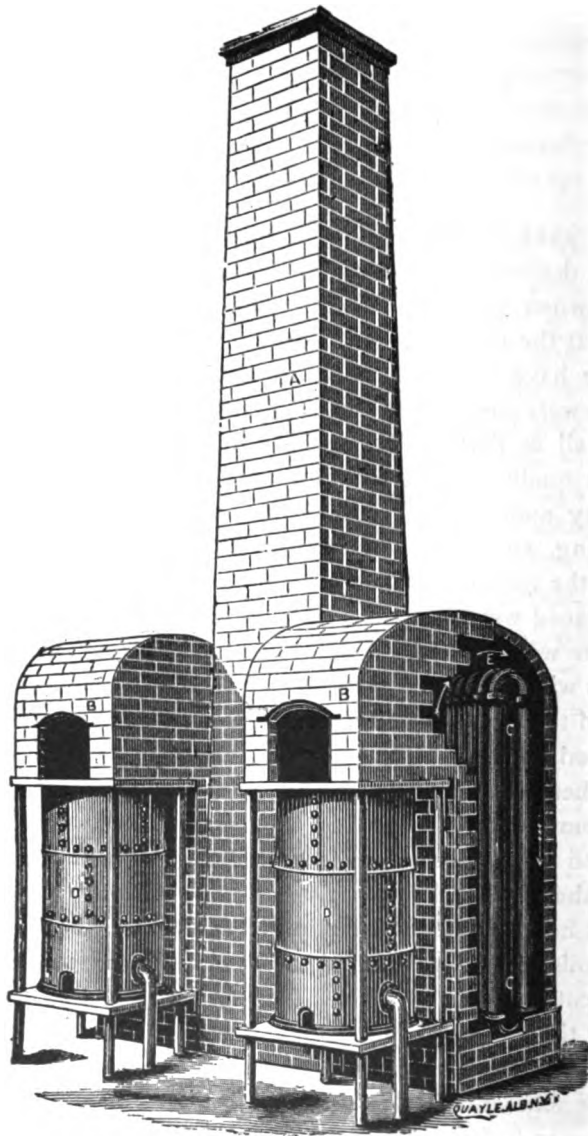

HOT BLAST CUPOLAS.

half of the heat. No perceptible improvement was made in the quality of the iron by the heating of the blast, and the greatest objection to these cupolas was the difficulty of keeping the coils of pipe intact. The heating of the pipe to a red heat every time the cupolas were put in blast and permitting them to cool before the next heat, in a short time destroyed the cohesive properties of the iron, and the pipe frequently broke after or during a heat and permitted the blast to escape into the oven. These breaks became so frequent and annoying after the pipe had been in use for a short time, and were so expensive to repair, that the slight saving effected in fuel did not justify a continued use of the hot blast, and it was abandoned. The cupolas were for a long time used without the hot blast, and the ovens proved excellent spark catchers. No sparks were ever thrown from the top of the high stack, and the ovens had frequently to be cleaned to remove them.

At the stove foundry of Ransom & Co., Albany, N. Y., a cupola was constructed with a large stack, and coils of pipe for heating the blast were placed in the stack directly over the cupola. The blast when passed through these pipes was heated to a high degree after the cupola had been in blast for a short time, but the pipes in this case broke after repeated heating and cooling, as in the ovens of the Jagger, Treadwell and Perry cupolas, and after the killing of a melter, by a piece of pipe falling upon him from the stack while picking out the cupola, the pipes were all removed from the stack and heating of the blast was discontinued. Several attempts have been made to take the escaping heat direct from the top of a cupola and return it into the cupola through the tuyeres; but in all cases this plan has, for lack of means to force the hot air into the cupola, proven a failure.

Exhaust pipes have been connected with the stack of a cupola and the inlets of the blower placed near the cupola, and hot air drawn from the stack by the blower and returned to the cupola through the tuyeres. This arrangement supplied a hot blast to the cupola with no expense for heating the blast, and was in the

early part of a heat in which it was tried, a success, when only a small amount of heat escaped from the cupola and the air drawn from the stack was heated only to a limited extent. But, as the melting progressed and the stock settled low in the cupola, the air drawn from the stack was heated to so high a degree as to heat and destroy a blower through which it was passed in being returned to the cupola. Could hot air have been taken from a cupola stack and returned to the cupola through the tuyeres without passing it through a blower, it would, no doubt, have effected a great saving in fuel in the days of low cupolas, when a large amount of the heat from fuel direct was not utilized in melting. But this could not be done, and after a number of experiments to secure a hot blast in this way, the plan was given up as a failure.

The blast for a cupola can be heated in a hot-blast oven similar to those some years ago used in heating the blast for furnaces, and which was done by furnaces specially constructed for the purpose, and not with gas taken from the furnaces as at the present time. But these ovens would be required to be kept continually hot to prevent breakage of the pipes by repeated heating and cooling. The saving of fuel effected in melting with a hot blast obtained in this manner, would not be sufficient to pay for the expense of heating the blast for a cupola that is only in blast for a few hours each day; and it is doubtful if the saving effected would justify the heating of the blast, if a cupola was kept constantly in blast, or the hot blast changed from one cupola to another as soon as the heat was melted.

WASTE HEAT FROM A CUPOLA.

A number of plans for utilizing the heat escaping from a cupola, besides using it for heating the blast, have been devised; such as utilizing it for heating the iron before charging it into the cupola, drying cores, ladles, etc. All these experiments were made years ago, when from six to ten feet was considered to be the proper height for a cupola, and fully one-half of the heat escaped from the top; but it was not until the height of

cupolas was increased that a practical means of utilizing all the heat of the fuel in melting was found. In a high cupola all the heat escaping from the melting zone is utilized to heat the stock in the cupola and prepare it for melting before the stock settles into the melting zone. The height that a cupola should be made in order to utilize all the heat depends upon its diameter, volume of blast, and the way in which the stock is charged. Cupolas of twelve to twenty inches in diameter must be made low, so that the stock in case it hangs up in the cupola may be dislodged with the bar, and all the heat cannot be utilized in these small cupolas except when a very small volume of blast is used. In this latter case the melting is slow, and it is more economical to permit part of the heat to escape, and do fast melting with a strong blast. Cupolas of large diameter may be made of a sufficient height to utilize all the heat, no matter how great the volume of blast or how openly the stock is charged. Cupolas of large diameter now in use in many foundries are from fifteen to twenty feet high, and those in the Carnegie Steel Works, Homestead, Pa., are thirty feet high. In these cupolas whole bars of pig iron are charged, and all the stock is dumped into the cupola from barrows, and no pains taken to pack it close to prevent the escape of heat. Yet no heat escapes from the top of the cupola when filled with stock, and it has not been found necessary to line the iron stacks with brick to prevent them being heated with heat escaping from the cupolas.

In low cupolas heat may to a large extent be prevented from escaping by breaking the pig and scrap into small pieces, and when charging packing it close. More time is then required for the heat to work its way through the stock in escaping from the melting zone, and a greater amount of it is utilized in heating the stock and preparing it for melting before it settles into the melting zone.

CHAPTER XIX.

SPARK CATCHING DEVICES FOR CUPOLAS.

FOUNDRYMEN whose plants are located in closely built up neighborhoods, are very much annoyed by sparks thrown out of their cupolas lighting upon the roofs of adjoining buildings and setting them on fire. In some cases they have on this account been compelled to move their plants from towns and cities to the suburbs. Many plans have been devised and tried for arresting these sparks; one of the oldest and most efficient of which is the design shown in Fig. 56. This arrangement was devised when the old-fashioned cupolas with brick stacks were in vogue, and was generally put up in such cases where cupola sparks were very objectionable. It consisted in constructing the stack upon an iron plate supported by iron columns, on a level with the top of the cupola. The end of this plate extended over the top of the cupola, with an opening in the plate equal to the inside diameter of the cupola, and on the plate was put a short stack, in which was placed the charging door, the top of which was arched over toward the main stack, with which it connected on the side.

Any sparks that arose from the cupola were thrown into the bottom of the main stack by the arch in the direction indicated by the arrows and were removed when cold, as often as the bottom of the stack filled up to such an extent as to interfere with the arrest of the sparks.

This arrangement was very effective in arresting sparks, but was not found to be a very convenient one for attaching to our modern cupolas, and numerous other plans have since been devised and used.

In Fig. 57 is seen a more modern spark-arrester than the one

just described. In this device, the casing is cut in two at the

FIG. 56.

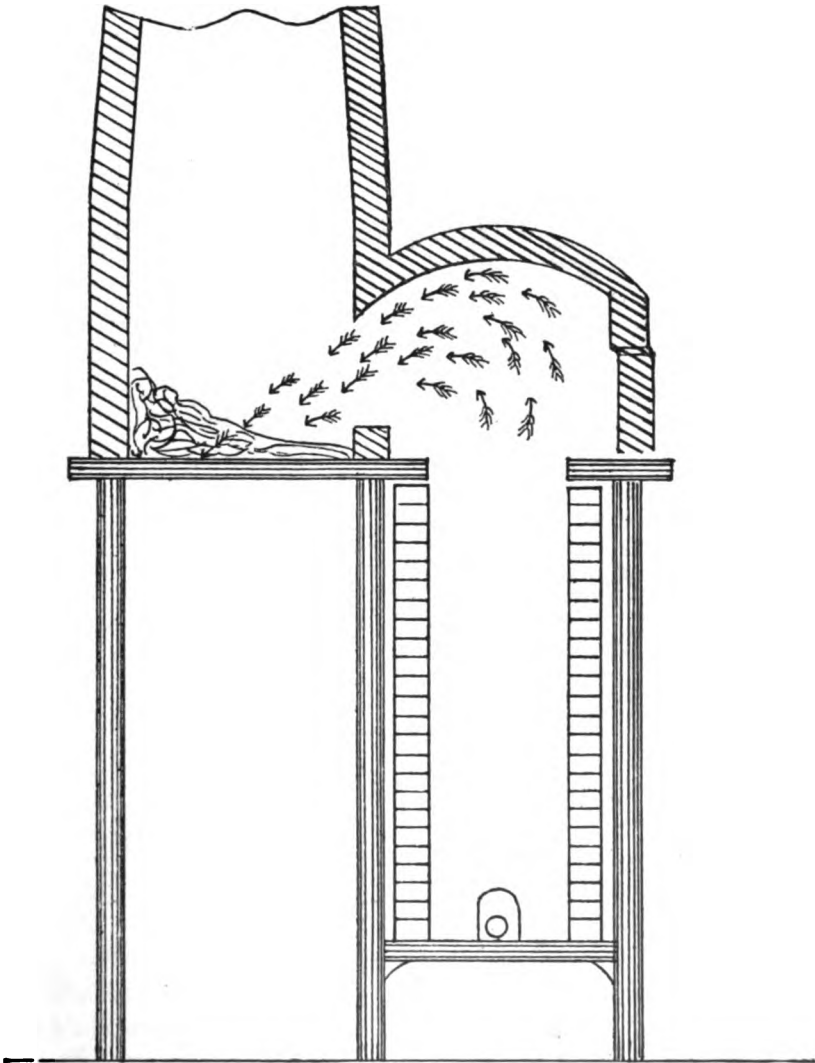

SPARK CATCHER IN OLD STYLE CUPOLA.

bottom of the charging door and an iron plate or ring placed

THE CUPOLA FURNACE.

FIG. 57.

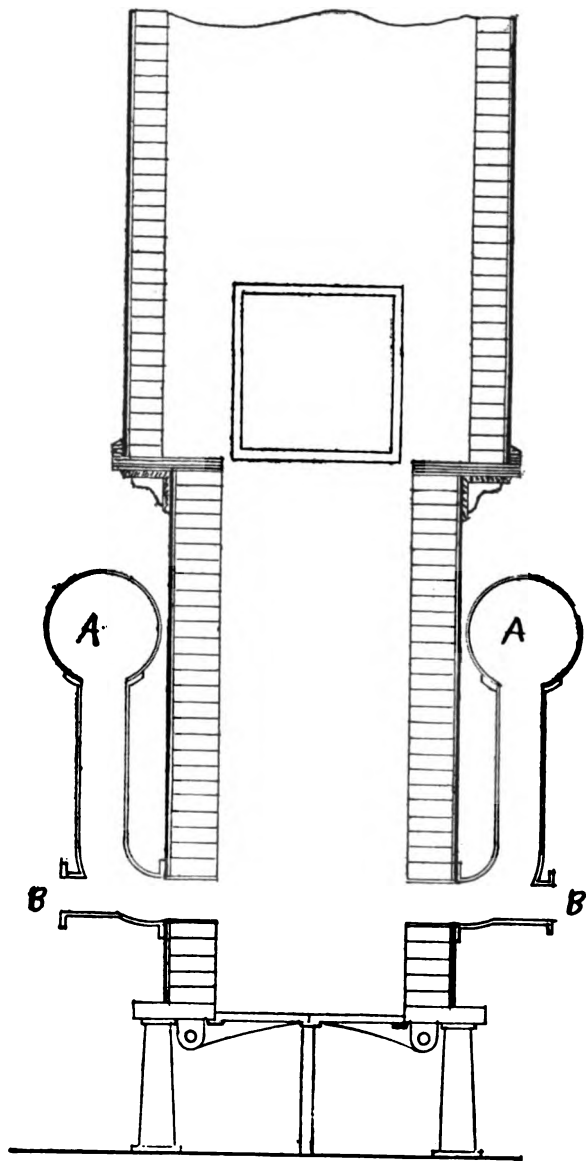

SPARK CATHING DEVICE IN MODERN CUPOLA.

upon the top of the cupola casing, where it is supported by the casing and cast iron brackets riveted or bolted to it on the outside. The inside of the plate or ring generally covers the top of the cupola lining to protect it when charging the stock, and the outside extends over the cupola casing from six to twelve inches. On this plate the stack casing, which is of larger diameter than the cupola casing, is placed and lined with a thin lining. The spark-arresting device consists in making the stack larger than the cupola, so that the blast loses its force when it emerges from the cupola and enters the stack, and the sparks carried out of the cupola fall back into it before reaching the top of the stack. The extent to which the stack should be enlarged to be effective in arresting sparks depends upon the height of it; low stacks requiring to be of a larger diameter than high ones.

In this illustration is shown a very neat arrangement for supplying blast to a cupola when a belt air-chamber riveted to the cupola shell is not used. The main blast-pipe *AA*, which encircles the cupola, is placed up out of the way, in catching iron or removing large ladles. The branch pipes are cast in one piece and tightly bolted or riveted to the main pipe and cupola casing, to prevent the escape of blast. The peep holes *BB* are cast in the pipe, and close with a tight-fitting swing cap and latch.

RETURN FLUE CUPOLA SPARK-CATCHER.

In Fig. 58 is shown a device designed by John O'Keefe, Superintendent of Perry & Co.'s Stove Works, Albany, N. Y., for catching sparks and saving fuel. The foundry of the firm in which this device was constructed, was located on Hudson St., in a closely built up part of the city, and they were very much annoyed by sparks from their cupola setting fire to roofs of buildings in the vicinity, and it became necessary to prevent sparks escaping or move their foundry. A number of devices, such as hoods, etc., were tried, but none of these proved effective, and a return flue was constructed. The arch or dome *A* was

FIG. 58.

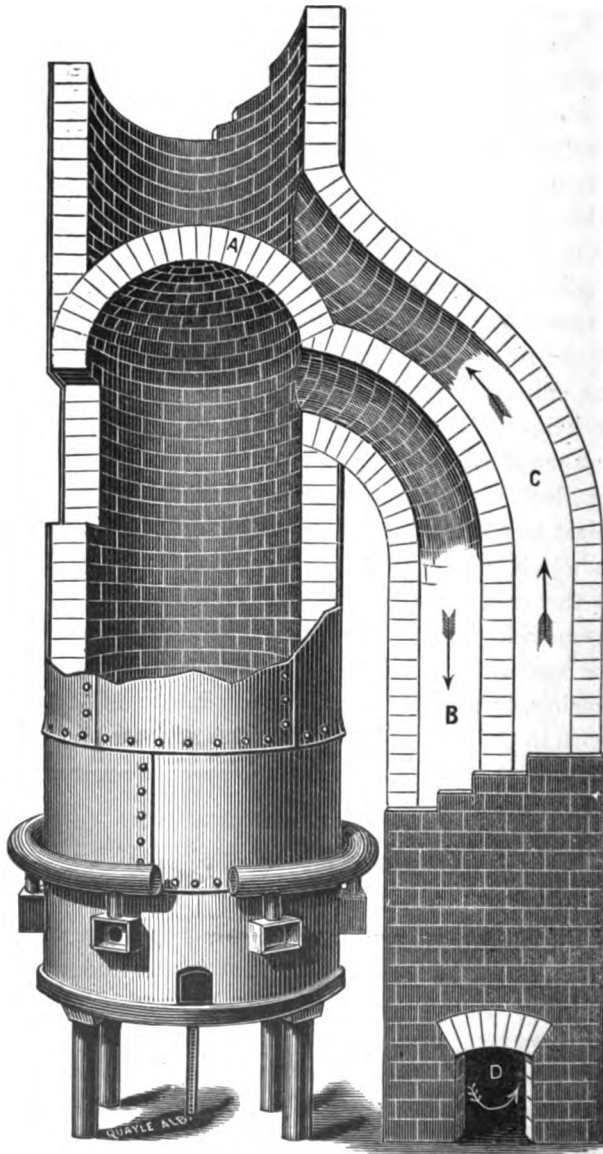

RETURN FLUE CUPOLA SPARK-CATCHER.

thrown across the cupola stack above the door, and the flue *B* led out of the cupola just below the dome and down to the foundry floor, from which point it returned to the stack above the dome. When the cupola was in blast, waste heat from the cupola struck the dome and was thrown back upon the stock in the cupola, or was forced down through the flue *B* and returned to the cupola stack through the flue *C* above the dome. When the cupola was put in blast it was found that so large an amount of heat and gas escaped from the door that the cupola could not be charged when in blast, and it became necessary to make a small opening through the dome to permit part of it to escape. Had the cupola been of a size to admit of all the stock being charged before the blast was put on and the door closed, during the heat, there is no doubt considerable fuel might have been saved, and faster melting done. But as it was, no fuel was saved, and there was no perceptible change in the time required to melt a heat. The device was effective in preventing the escape of sparks and small pieces of fuel from the stack, for they were all thrown back into the cupola or deposited in the bottom of the flue, from which they were removed through the opening *D* at the bottom of the flue, as frequently as found necessary.

OTHER SPARK CATCHING DEVICES.

Another device for arresting sparks is to place a half circle fire-brick arch opened at both ends on the top of the stack, making its total length and breadth equal to the outside diameter of the stack. This plan arrests the sparks in their upward course and some of them fall back into the cupola, but many are carried out at the ends of the arch by the blast and fall upon the foundry roof, and on windy days may be carried to adjoining roofs.

Iron caps or hoods are also placed one or more feet above the top of cupola stacks to arrest sparks; but they, like the arch, only arrest the sparks in their upward flight and throw many of them down upon the foundry or scaffold roof.

Another plan for preventing the escape of sparks is to suspend an iron disk of a few inches smaller diameter than the stack in the stack near the top. The sparks strike this disk and are thrown back into the cupola. But this device cannot be used in contracted stacks with a strong blast, and in large ones the cohesive properties of the iron are soon destroyed by the heat and gases of the cupola, and if not frequently replaced there is danger of it breaking from the jar in chipping out the cupola, and falling upon the melter.

THE BEST SPARK CATCHING DEVICE.

The cause of sparks being thrown from a cupola is the strong blast forced into the cupola at the tuyeres, which carries small pieces of fuel out at the top of the stack during the heat, and large pieces near the end of a heat, when the stock is low in the cupola and the blast passes through it more freely. The lifting power of the blast is increased by confining it in a contracted stack, and good-sized pieces of fuel may be thrown several feet above the top of a small stack; but the instant the blast escapes from the top of the stack it expands and its lifting power is lost, and sparks or pieces of fuel fall by their own weight and may in their descent be carried to some distance by a strong wind.

CHAPTER XX.

BLAST PIPES AND BLAST.

BLAST PIPES.

IN constructing a cupola, one of the most important points to be considered is the construction and arrangement of blast pipes and their connection with the cupola, for the best constructed cupola may be a complete failure through bad arrangement of pipes and air-chambers.

Not many years ago it was a common practice of foundrymen to place blast pipes underground. The main pipe was generally made square and constructed of boards or planks spiked together, no care being taken to make air-tight joints, and the escape of blast was prevented by ramming sand or clay around the pipe when put in place. Connections from the main pipe to the cupola were made by means of vertical cast-iron pipes to each tuyere, as shown in Figs. 31 and 32. The iron pipes were generally constructed with square elbows and ends, and the tuyere pipes were placed over an opening in the top of a branch of the main pipe on each side of the cupola. The square turns and ends of the pipe greatly reduced the force of the blast, and the capacity of the pipe was frequently reduced by water leaking into it or a partial collapse of the pipe, and the volume of blast delivered to a cupola was very uncertain even when the pipes were new, and could not be depended upon at all when the pipes became old and rotten. Iron pipes arranged in this way were also a source of continual annoyance and uncertainty from water or iron and slag from the tuyeres getting into them and reducing their capacity for conveying blast. This way of arranging cupola pipes has generally been abandoned, and they are now commonly placed overhead or

up where they are least liable to injury and may be readily examined to see that there is no leakage of blast from a pipe.

Blast pipes may be made of wood, tin plate, sheet iron, cast iron, or galvanized iron. Wooden pipes shrink and expand with changes of weather and moisture in the atmosphere, and it is almost impossible to prevent the escape of blast from such pipes. Tin and sheet-iron pipes, when placed in a foundry, are very rapidly rusted and destroyed by steam and gases escaping from moulds and the cupola, if not thoroughly painted outside and in. Cast iron pipes are heavy, difficult to support in place, liable to break when not properly supported, or leak at the joints, and the best for foundry use are those made of galvanized iron. In constructing pipes of this material, an iron of a proper gauge for the size of pipe should be selected, and their shape should, whenever possible, be round, for round pipes are more easily constructed and have the largest effective area with a given perimeter of any known figure. Pipes should be made in lengths convenient for handling, say 8 or 10 ft., having joints lapped nearly 2 inches in direction of the air current. Joints should be riveted about every 4 inches, to hold them securely together and prevent sagging of the pipe between supports, and to insure their being tight they should be soldered all the way around. Section ends should be placed over supports and laps of from 3 to 4 inches made at each joint and also soldered. The end of the main pipe, when not connected direct with an air chamber on the cupola, should be divided into two or more branches of equal capacity for connection with the tuyeres or air belt, and rounded curves or elbows used in changing the direction of pipes. A pipe should never terminate abruptly, and branches should not be taken out of the side for supplying the cupola, as is frequently done. The area of main pipes and also branch pipes should be increased as the distance from the blower to the cupola is increased; and as a guide for increasing their diameter in proportion to the length of pipe, we do not think we can do better than give our readers the excellent table prepared by the Buffalo Forge Co., Buffalo, N. Y., as follows:

DIAMETER OF BLAST PIPES.

It will be seen, by reference to the following table, that the diameter of pipe for transmitting or carrying air from one point to another, changes with the length or distance which the air is carried from the blower to the furnace, or other point of delivery.

As air moves through pipes, a portion of its force is retarded by the friction of its particles along the sides of the pipe, and the loss of pressure from this source increases directly as the length of the pipe, and as the square of the velocity of the moving air.

This fact has long been known, and many experimenters and engineers, by close observation and long-continued experiments, have established formulas by which the loss of pressure and the additional amount of power required to force air or gases through pipes of any length and diameter may be computed.

As these formulas are commonly expressed in algebraic notation, not in general use, we have thought it desirable to arrange a table showing at a glance all the necessary proportionate increase in diameter and length of blast pipes and conical mouth-pieces, in keeping up the pressure to the point of delivery. It is often the case, where a *blower is condemned as being insufficient*, the cause of its failure is that the pipe connections are too small for their lengths, coupled with a large number of short bends, without regard to making the pipe tight, which is a necessity.

The table, diameter of pipes, given on the following page, showing the necessary increase in the size of pipes in proportion to the lengths, is what we call a practical one, and experience has proved the necessity for it.

The connection of blast pipes with cupolas is also a matter to which entirely too little attention is given, and is frequently the cause of poor melting when cupola is otherwise properly constructed. As stated elsewhere, tuyeres should be large enough to admit blast to a cupola freely, and to obtain good

TABLE SHOWING THE NECESSARY INCREASE IN DIAMETER FOR THE DIFFERENT LENGTHS.

LENGTH OF PIPE.	30 Ft.	60 Ft.	90 Ft.	120 Ft.	150 Ft.	180 Ft.	210 Ft.	240 Ft.	270 Ft.	300 Ft.
Diameter of Blower Outlet in Inches.	Diameter of Pipe should be	Diameter of Pipe should be	Diameter of Pipe should be	Diameter of Pipe should be	Diameter of Pipe should be	Diameter of Pipe should be	Diameter of Pipe should be	Diameter of Pipe should be	Diameter of Pipe should be	Diameter of Pipe should be
3.....	3 $\frac{1}{4}$	3 $\frac{5}{8}$	4	4 $\frac{1}{4}$	4 $\frac{1}{2}$	4 $\frac{3}{4}$	5	5 $\frac{1}{8}$	5 $\frac{3}{8}$	5 $\frac{1}{2}$
3 $\frac{1}{2}$	3 $\frac{3}{4}$	4 $\frac{1}{8}$	4 $\frac{1}{2}$	4 $\frac{7}{8}$	5	5 $\frac{1}{4}$	5 $\frac{1}{2}$	5 $\frac{5}{8}$	5 $\frac{3}{4}$	5 $\frac{7}{8}$
4.....	4 $\frac{3}{8}$	4 $\frac{3}{4}$	5 $\frac{1}{8}$	5 $\frac{3}{8}$	5 $\frac{3}{4}$	6	6 $\frac{1}{4}$	6 $\frac{1}{2}$	6 $\frac{3}{4}$	6 $\frac{3}{4}$
4 $\frac{1}{2}$	5	5 $\frac{5}{8}$	5 $\frac{3}{4}$	6	6 $\frac{1}{8}$	6 $\frac{3}{4}$	7	7 $\frac{1}{4}$	7 $\frac{1}{4}$	7 $\frac{1}{2}$
5.....	5 $\frac{1}{2}$	6	6 $\frac{1}{8}$	6 $\frac{3}{4}$	6 $\frac{5}{8}$	7 $\frac{1}{2}$	7 $\frac{3}{4}$	8 $\frac{1}{8}$	8 $\frac{1}{8}$	8 $\frac{1}{2}$
6.....	6 $\frac{1}{2}$	7	7 $\frac{5}{8}$	8	8 $\frac{1}{2}$	9	9 $\frac{3}{4}$	10 $\frac{1}{8}$	10 $\frac{1}{8}$	10 $\frac{1}{2}$
7.....	7 $\frac{5}{8}$	8 $\frac{1}{4}$	8 $\frac{3}{8}$	9 $\frac{3}{8}$	10	10 $\frac{3}{8}$	10 $\frac{3}{8}$	11 $\frac{1}{8}$	11 $\frac{1}{8}$	11 $\frac{1}{2}$
8.....	8 $\frac{3}{4}$	9 $\frac{1}{4}$	10 $\frac{1}{8}$	10 $\frac{3}{4}$	11 $\frac{3}{8}$	11 $\frac{7}{8}$	12 $\frac{1}{8}$	12 $\frac{3}{8}$	13 $\frac{1}{8}$	13 $\frac{1}{2}$
9.....	10	10 $\frac{3}{4}$	11 $\frac{1}{2}$	12 $\frac{1}{8}$	12 $\frac{3}{4}$	13 $\frac{1}{4}$	14	14 $\frac{1}{2}$	15 $\frac{1}{2}$	15 $\frac{5}{8}$
10.....	11	11 $\frac{7}{8}$	12 $\frac{3}{4}$	13 $\frac{3}{8}$	14 $\frac{1}{4}$	14 $\frac{3}{4}$	15 $\frac{1}{2}$	16 $\frac{1}{4}$	16 $\frac{3}{4}$	17 $\frac{1}{8}$
11.....	12	13	13 $\frac{3}{4}$	14 $\frac{3}{4}$	15 $\frac{3}{8}$	16 $\frac{3}{4}$	17 $\frac{3}{8}$	18 $\frac{1}{4}$	18 $\frac{3}{4}$	19 $\frac{1}{2}$
12.....	13 $\frac{1}{8}$	14 $\frac{1}{4}$	15 $\frac{1}{4}$	16 $\frac{1}{8}$	17	17 $\frac{3}{4}$	18 $\frac{3}{8}$	19 $\frac{3}{8}$	20 $\frac{1}{8}$	20 $\frac{3}{8}$
13.....	14 $\frac{1}{4}$	15 $\frac{1}{8}$	16 $\frac{1}{2}$	17 $\frac{3}{8}$	18 $\frac{3}{8}$	19 $\frac{3}{4}$	20 $\frac{3}{8}$	21 $\frac{1}{4}$	21 $\frac{3}{4}$	22 $\frac{1}{8}$
14.....	15 $\frac{1}{8}$	16 $\frac{3}{8}$	17 $\frac{3}{4}$	18 $\frac{3}{4}$	19 $\frac{3}{4}$	20 $\frac{3}{4}$	21 $\frac{3}{4}$	22 $\frac{3}{4}$	23 $\frac{1}{4}$	23 $\frac{1}{2}$
15.....	16 $\frac{1}{2}$	17 $\frac{3}{4}$	19	20 $\frac{1}{8}$	21 $\frac{1}{4}$	21 $\frac{1}{4}$	22 $\frac{1}{2}$	23 $\frac{1}{2}$	24 $\frac{1}{2}$	24 $\frac{1}{2}$
16.....	17 $\frac{1}{2}$	19	20 $\frac{3}{8}$	21 $\frac{3}{8}$	22 $\frac{3}{8}$	23 $\frac{3}{4}$	24 $\frac{3}{4}$	25 $\frac{3}{4}$	26 $\frac{3}{4}$	27 $\frac{1}{4}$
17.....	18 $\frac{1}{2}$	20 $\frac{3}{8}$	21 $\frac{1}{2}$	22 $\frac{3}{4}$	24	24 $\frac{3}{4}$	25 $\frac{3}{4}$	26 $\frac{3}{4}$	28 $\frac{1}{2}$	29 $\frac{1}{4}$
18.....	19 $\frac{3}{4}$	21 $\frac{3}{8}$	22 $\frac{3}{4}$	24 $\frac{1}{4}$	25 $\frac{1}{2}$	26 $\frac{3}{4}$	27 $\frac{3}{4}$	29 $\frac{1}{8}$	30 $\frac{1}{8}$	31 $\frac{1}{4}$
19.....	20 $\frac{3}{8}$	22 $\frac{3}{8}$	23 $\frac{3}{4}$	25 $\frac{3}{8}$	27 $\frac{1}{2}$	28 $\frac{3}{4}$	29 $\frac{3}{8}$	30 $\frac{3}{4}$	31 $\frac{3}{8}$	33
20.....	22	23 $\frac{3}{8}$	25 $\frac{3}{8}$	27 $\frac{3}{8}$	28 $\frac{3}{4}$	29 $\frac{3}{4}$	31	32 $\frac{1}{4}$	33 $\frac{1}{2}$	34 $\frac{3}{4}$
21.....	23	24 $\frac{1}{8}$	26 $\frac{3}{8}$	28 $\frac{1}{4}$	29 $\frac{1}{4}$	31 $\frac{1}{8}$	32 $\frac{1}{2}$	33 $\frac{1}{2}$	35 $\frac{1}{4}$	36 $\frac{3}{8}$
22.....	24 $\frac{1}{8}$	26 $\frac{1}{8}$	27 $\frac{1}{8}$	29 $\frac{1}{8}$	31 $\frac{1}{8}$	33 $\frac{1}{8}$	34 $\frac{1}{2}$	35 $\frac{1}{2}$	37 $\frac{1}{8}$	38 $\frac{1}{8}$
23.....	25 $\frac{1}{4}$	27 $\frac{1}{4}$	29 $\frac{1}{4}$	30 $\frac{1}{4}$	31 $\frac{3}{8}$	33 $\frac{3}{8}$	35 $\frac{3}{8}$	37 $\frac{3}{8}$	38 $\frac{3}{8}$	39 $\frac{3}{8}$
24.....	26 $\frac{1}{4}$	28 $\frac{1}{4}$	30 $\frac{1}{4}$	32 $\frac{1}{4}$	34 $\frac{1}{4}$	35 $\frac{1}{4}$	37 $\frac{1}{4}$	38 $\frac{1}{4}$	40 $\frac{1}{4}$	41 $\frac{1}{8}$
Length of pipe.....	30 ft.	60 ft.	90 ft.	120 ft.	150 ft.	180 ft.	210 ft.	240 ft.	270 ft.	300 ft.
Length of mouth-piece..	9 in.	15 in.	21 in.	27 in.	33 in.	36 in.	42 in.	48 in.	54 in.	60 in.

results in melting it must be fully and evenly distributed to the tuyeres. When blast is delivered direct to tuyeres through branch pipes, the branches should be taken off the main pipe in as near a direct line with the current of the blast in the main pipe as possible, and its course to the tuyeres should be changed by long curves or round elbows in the pipes, to prevent the velocity of the air being checked and blast thrown back in the pipe. The combined area of all the branch pipes should be equal to the area of the main pipe, and not less as is frequently the case, owing to a mistake being made through the erroneous idea that a multiple of the diameter of two or more small pipes is equal to the area of one large one of their combined diameters. If this were the case two five-inch pipes would have an area equal to one ten-inch pipe, which is not so, as will be seen by the table on p. 285, which may be of value to foundrymen in arranging their blast pipes.

DIAMETER AND AREA OF PIPES.

Diameter.	Area.	Diameter.	Area.	Diameter.	Area.
2	3.141	8 $\frac{1}{4}$	53.456	14 $\frac{1}{2}$	165.13
2 $\frac{1}{4}$	3.967	8 $\frac{1}{2}$	56.745	14 $\frac{3}{4}$	170.85
2 $\frac{1}{2}$	4.908	8 $\frac{3}{4}$	60.132	15	176.71
2 $\frac{3}{4}$	5.939	9	63.617	15 $\frac{1}{4}$	182.65
3	7.068	9 $\frac{1}{4}$	67.200	15 $\frac{1}{2}$	188.69
3 $\frac{1}{4}$	8.295	9 $\frac{1}{2}$	70.882	15 $\frac{3}{4}$	194.82
3 $\frac{1}{2}$	9.621	9 $\frac{3}{4}$	74.662	16	201.06
3 $\frac{3}{4}$	11.044	10	78.539	16 $\frac{1}{4}$	207.39
4	12.566	10 $\frac{1}{4}$	82.516	16 $\frac{1}{2}$	213.82
4 $\frac{1}{4}$	14.186	10 $\frac{1}{2}$	86.590	16 $\frac{3}{4}$	220.35
4 $\frac{1}{2}$	15.904	10 $\frac{3}{4}$	90.762	17	226.98
4 $\frac{3}{4}$	17.720	11	95.033	17 $\frac{1}{4}$	233.70
5	19.635	11 $\frac{1}{4}$	99.402	17 $\frac{1}{2}$	240.52
5 $\frac{1}{4}$	21.647	11 $\frac{1}{2}$	103.86	17 $\frac{3}{4}$	247.45
5 $\frac{1}{2}$	23.758	11 $\frac{3}{4}$	108.43	18	254.46
5 $\frac{3}{4}$	25.967	12	113.09	18 $\frac{1}{4}$	261.58
6	28.274	12 $\frac{1}{4}$	117.85	18 $\frac{1}{2}$	268.80
6 $\frac{1}{4}$	30.679	12 $\frac{1}{2}$	122.71	18 $\frac{3}{4}$	276.11
6 $\frac{1}{2}$	33.183	12 $\frac{3}{4}$	127.67	19	283.52
6 $\frac{3}{4}$	35.784	13	132.73	19 $\frac{1}{4}$	291.03
7	38.484	13 $\frac{1}{4}$	137.88	19 $\frac{1}{2}$	298.64
7 $\frac{1}{4}$	41.282	13 $\frac{1}{2}$	143.13	19 $\frac{3}{4}$	306.35
7 $\frac{1}{2}$	44.178	13 $\frac{3}{4}$	148.48	20	314.16
7 $\frac{3}{4}$	47.173	14	153.93		
8	50.265	14 $\frac{1}{4}$	159.48		

In connecting blast pipes direct with tuyeres, either by long branch pipes from the main pipe or short ones from a belt air chamber not attached to cupola shell, care should be taken to have as few joints or connections in the pipes as possible, and every joint should be made in such a way that the jar made in chipping out and charging the cupola will not cause the joints to leak after they have been in use a short time. In leading pipes out of an air chamber they cannot always be placed in line with the current of the blast, and must be filled from pressure of blast in the air chamber, but the connecting pipes may be shaped to guide the blast smoothly from the air chamber to its destination.

In Fig. 56 is shown as perfect a connection of air chambers of this kind as can be made. In this illustration the belt pipe *A A* is placed up out of the way and of danger of being injured when making up or working the cupola, and the branch pipes to each tuyere are straight and smooth inside and the pipe is given a curve at the bottom to throw the blast into the tuyere without having the force of its current impaired, and the tuyeres are of a size to admit the full volume of blast from the pipe. Only two joints are required in connecting the air chamber with the cupola, and these are made in such a way that they may be securely bolted or riveted, and all leakage prevented.

In contrast with the neat arrangement of pipes on this cupola is shown the other extreme of poor arrangement in illustration Figure 59. This is a section of a "perfect cupola" illustrated and described in *The Iron Age* some years ago, and while other parts of the cupola may have been perfect, this part was certainly very imperfect. The air chamber and its connecting pipes are made of cast iron. The connecting pipes are cast in three pieces, necessitating the making of four joints. The air box is cast in two pieces, requiring another joint; and a peep-hole and an opening for escape of slag and iron running into the tuyeres, is placed in the pipe, making in all seven joints and openings in each connection to be made and kept air-tight. The jar in working the cupola, together with the small explo-

sions of gas that frequently take place in cupolas and pipes,

FIG. 59.

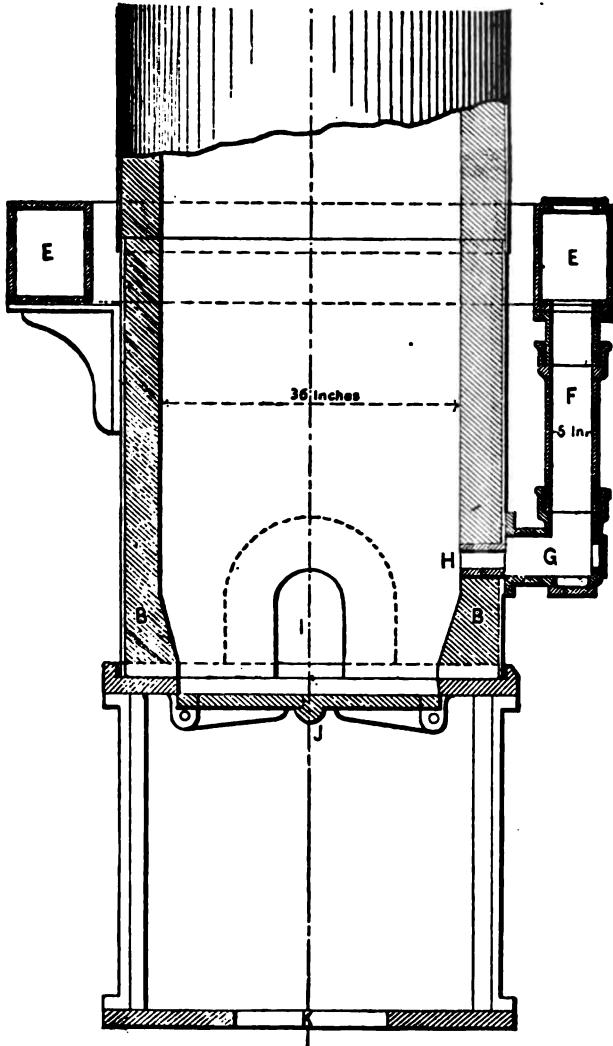

POOR ARRANGEMENT OF BLAST PIPES.

would naturally tend to loosen many of these joints, and a large

amount of blast would be lost through leakage of joints. The many joints make more or less roughness in the pipes, thus impeding the blast. The turn in the pipe for connection with the tuyere is square and the course of the current of air is abruptly changed, and the tuyere is entirely too small to admit the full volume of blast from the pipe to the cupola, and only by a heavy pressure of blast could the air be forced into the cupola in sufficient quantities to do good melting.

In Fig. 57 is shown another way of connecting a belt air-chamber with the tuyeres. In this case the pipe is made of galvanized iron, and the tuyere boxes are made of cast-iron and are large, giving abundant room for changing the direction of the blast current. Only two joints are made in connecting the air-chamber with the cupola; beside these joints, the end of the tuyere box is closed with a large door, the full size of the box, and a peep-hole is placed in the door, making two more openings to be kept air-tight. Many cupolas are in use having their blast connections arranged in this way, and while the arrangement is good, it is not perfect, and a great deal of blast is lost through leakage of joints—the principal loss occurring around the large door and at the joint connecting the galvanized iron pipe with the cast-iron tuyere box.

The very best way of connecting blast pipes with cupola tuyeres is by means of a belt air-chamber riveted to the cupola casting, as shown in Figs. 39, 43 and 45, or by an inside air-chamber, as shown in Figs. 31 and 46. In either case the air-chamber is riveted to the cupola shell and the joint made perfectly air-tight, and in case of jar to the cupola, the air-chamber being part of the cupola, oscillates with it, and the jar in chipping out and charring does not loosen the joint and cause leakage of blast. The blast pipes may also be securely riveted or bolted to the air-chamber and a perfectly tight joint made. In constructing cupolas in this way, care should be taken to make the air-chamber of a sufficient size to admit of a free circulation of blast and supply all the tuyeres with an adequate amount for good melting. When the air-chamber is small, the blast-pipe

should be connected with it on each side of the cupola, and on the side or top as found most convenient. When the chamber is large and there is an abundance of room for the escape of blast from the pipe, one pipe is sufficient and it may be connected on the side or top. When attached on the side it should be placed in line with the circle of the cupola as shown in Fig. 48, to cause the current of blast to circulate around the cupola and facilitate its escape from the pipe. When

FIG. 60.

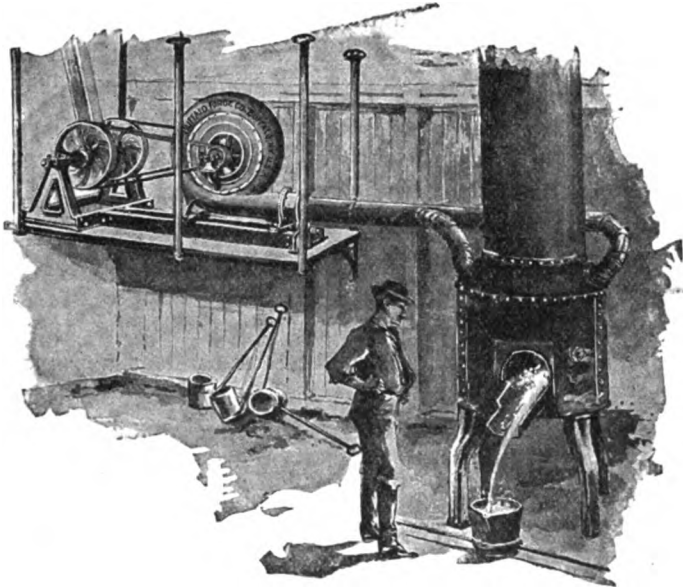

BLOWER PLACED NEAR CUPOLA.

the current of blast is thrown directly against the cupola casing or bottom of the chamber in a narrow air-chamber, the mouth of the pipe should be enlarged, to facilitate the escape of blast into the chamber; for cupolas of this construction may be made a complete failure by failing to provide a sufficient space at the end of the pipe for escape of blast into the air-chamber, when the chamber is of a sufficient size to supply the cupola. Con-

nections with the inner air-chambers of limited capacity should be made on each side by means of an air or tuyere box placed outside, as shown in Fig. 6, and the pipe connected on top to equalize the volume of blast supplied to each tuyere.

Long blast pipes often cause poor melting, from the volume of blast delivered to a cupola being reduced by friction in the pipes, and in all cases the blower should be placed as near the cupola as possible. In Fig. 60 is shown a very neat arrangement in placing a blower near a cupola and at the same time having it up out of the way of removing molten iron or the dump from the cupola, and the space under it may be utilized for storing ladles, etc. In this illustration is also shown a very perfect manner of connecting the main pipe with an air chamber. The pipe is divided into two branches of equal size in line with the current of blast from the blower, and connected with the air chamber on each side by curved pipes arranged in such a way as not to check the current of air as it passes through the pipe.

PLACING A BLOWER.

A blower should always be placed at as near a point to a cupola as is consistent with the arrangement of the foundry-plant, and it should be laid upon a good, solid foundation, and securely bolted to prevent jarring, as there is nothing that wrecks a blower so quickly as a continual jar when running at high speed. In Fig. 60 is shown a convenient way of placing a blower near a cupola, and at the same time having it out of the way. But when so placed, the blower should be laid upon a solid frame-work of heavy timber, and securely bolted down to prevent jarring when running. It should also be boxed in to prevent air being drawn in from the foundry, and have an opening provided for supplying air from the outside, for air drawn from a foundry when casting and shaking out are taking place is filled with dust and steam, which are very injurious to a blower and pipes.

A blower should never for the same reason be placed in a

cupola-room or a scratch room in which castings are cleaned ; for it is impossible to exclude dust from the bearings when so placed, and when a bearing once begins to cut, it makes room for a greater amount of dust, and cuts out very rapidly in blowers run at high speed. Dust and steam also corrode and destroy blast wheels which are inside the blower and out of sight, and a blast wheel may be almost entirely destroyed and not discovered until it is found the cupola is receiving no blast. To prevent a blower from being destroyed in this way, and insure a proper volume of blast for a cupola, the blower should be placed in a clean, dry room and supplied with pure air from the outside. If it cannot be so placed near a cupola, it had better be placed at some distance, in which case the blast-pipe must be enlarged in proportion to its length, as described elsewhere. When a blower is placed in a closed room, windows should be opened to admit air when it is running, and when the air about the room is filled with dust, a pipe or box for supplying pure air should be run off to some distance from the blower and the room kept tightly closed.

BLAST GATES.

These devices are especially designed for opening and closing blast pipes, such as are employed for conveying air between blowers and cupolas. There are several different designs of blast gates, but the one shown in Fig. 61 is the one most commonly used by foundrymen. They are manufactured and kept in stock by all the leading manufacturers of blowers, and cost from one dollar upwards, according to size of blast pipe.

The employment of the blast gate places the volume of blast delivered to a cupola under control of the melter, which feature is frequently very important in the management of cupolas in melting iron for special work, or in case of accident or delay in pouring. In foundries in which the facilities for handling molten metal are limited and melting must at times be retarded, to facilitate its removal from the cupola as fast as

melted, and in foundries where the amount of iron required to be melted per hour is limited by the number of molds or chills employed, from which castings are removed and the molds re-filled, it is very important that the blast should be under control of the melter. In such foundries the cupolas are generally of small diameter and frequently kept in blast for a number of hours at a time, and it is often desired to increase the volume of blast to liven up the iron, and decrease it to reduce the amount melted in a given time.

The blast gate places the blast under control of the melter and enables him to increase or diminish its volume as deemed

FIG. 61.

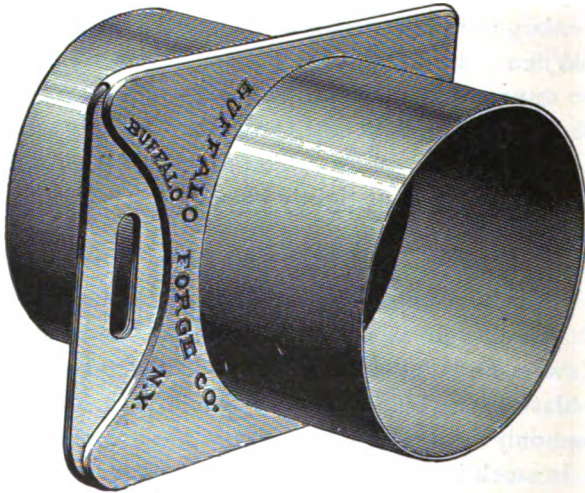

BLAST GATE.

necessary to obtain the best results in melting. They are often of value in regular cupola practice to reduce the volume of blast and retard melting for a few minutes while pouring a large piece of work, in foundries where the facilities for handling large quantities of molten iron are limited, and the speed of blower cannot be reduced without reducing the speed of machinery in other parts of the works or stopping the blower

entirely, which is not good practice after a cupola has been in blast for some time.

The gate is also a safeguard against gas explosions, which often occur from the accumulation of gas in pipes during the temporary stoppage of the blower. The gate should always be placed in the pipe near the cupola, and closed before stopping the blower and not opened until it is again started up.

EXPLOSIONS IN BLAST PIPES.

Violent explosions frequently take place in cupola blast pipes, tearing them asunder from end to end. These explosions are due to the escape of gas from the cupola into the pipes during a temporary stoppage of the blower in the course of a heat. The explosion is caused by the gas being ignited when the pipe becomes over-charged, or the instant the blower is started and the gas is forced back into the cupola. Such explosions generally take place in pipes placed high or arranged in such a way as to have a draught toward the blower. But they may occur in any pipe if the cupola is well filled when a stoppage takes place and the blower is stopped for a great length of time.

Such explosions may be prevented by closing the blast-gate if placed near the cupola, or by opening the tuyere doors in front of each tuyere and admitting air freely to the pipe. Such precaution should always be taken the instant the blast is stopped, as a pipe may be exploded after only a few minutes' stoppage of the blower, and men may be injured or the blower destroyed by the explosion.

BLAST GAUGES.

A number of air or blast gauges have been designed and placed upon the market for determining the pressure of blast in cupola blast pipes and air-chambers. These gauges are of a variety of design, and are known as *steel spring*, *water* and *mercury gauges*. They are connected with a blast pipe or air-chamber by means of a short piece of gas-pipe or a piece of

small rubber hose, through which the air is admitted to the gauge. The pressure of blast is indicated by a face dial and hand on the spring gauge, and the graduated glass tube of the water and mercury gauges, pressure being shown up to two pounds, in fractions of an ounce. These gauges, when in good order, indicate very accurately the pressure of blast on a cupola, and when tuyeres and pipes are properly arranged, show to some extent the resistance offered to the free escape of blast from the pipe and the condition of the cupola in melting. But they do not indicate the number of cubic feet of air that pass into a cupola in any given length of time, and a gauge may show a pressure of six or eight ounces when scarcely a cubic foot of air is passing into a cupola per minute.

With a pressure blower these gauges show a gradual increase of pressure in the pipe when a cupola is clogging up, and may enable a foundryman to prevent bursting of the pipe; but with a non-positive blower they show nothing that is of any value to a foundryman in melting, so far as we have been able to learn. The volume of blast is what does the work in a cupola, and not the pressure; and a high pressure of blast does not always indicate a large volume of blast, but rather the reverse, for little if any pressure can be shown on a gauge when blast escapes freely from a pipe.

We have seen two cupolas of the same diameter, one melting with a two-ounce pressure of blast and the other with a six-ounce pressure, and the cupola with the low pressure doing the best melting. This was simply because with the low pressure the air was escaping from the pipe into the cupola and with the high pressure it was not, and the high pressure was wholly due to the smallness of the tuyeres which prevented the free escape of blast from the pipe into the cupola.

A definite number of cubic feet of air has been determined by accurate experiments to be required to melt a ton of iron in a cupola, and an air-gauge to be of any value in melting must indicate the number of cubic feet of air that actually enter a cupola at the tuyeres. We have at the present time no such

gauge, and in the absence of such a gauge the foundryman's best guide as to the number of cubic feet of air supplied to his cupola is the tables furnished by all manufacturers of standard blowers, giving the number of revolutions at which their blowers should be run, and the number of cubic feet of air delivered at each revolution. From these tables a foundryman may figure out the exact number of cubic feet of air his cupola receives, provided there is no leakage of air from pipes or tuyeres and the tuyeres are of a size that will permit the air to enter the cupola freely.

BLAST IN MELTING.

A cupola furnace requires a large volume of air to produce a thorough and rapid combustion of fuel in the melting of iron or other metals in the furnace. Numerous means have been devised for supplying the required amount of air, among them the draught of a high chimney or stack, and the creating of a vacuum in the cupola by means of a steam jet, placed in a contracted outlet of a cupola as shown in Figs. 28 and 29. These means of supplying air are a success in cupolas of small diameter and limited height, but even in these cupolas the volume of air that can be drawn in is not sufficient to produce rapid melting, and it is doubtful if iron could be melted at all in a cupola of large diameter and of a proper height to do economical melting, by either of these means of supplying air. Owing to the peculiar construction of a cupola furnace and the manner of melting, the free passage of air through it is restricted by the iron and fuel required; and rapid melting can only be done when air for the combustion of the fuel is supplied in a large volume, which can only be by a forced blast.

A number of machines have been devised for supplying this blast, among the earliest of which were the leather bellows, trompe or water blast, chain blast, cogiardelle or water-cylinder blast, cylinder or piston blower. These have, as a rule, given away to the more modern fan blower and rotary positive blast blower, a number of which will be described later on.

The relative merits of a positive and non-positive blast, is a very much disputed question. It is claimed by many, that with a positive blast a definite amount of air is supplied to a cupola per minute or per hour, while with a non-positive blower or fan there is no certainty as to the amount of air the cupola will receive. This is very true, for a cupola certainly does not receive the same amount of air from a fan blower when the tuyeres and cupola are beginning to clog as it does from a positive blower when there is no slipping of the belts. But is it advisable to supply a cupola with as large a volume of blast when in this condition as when working open and free? Does not the large volume of blast have a chilling effect upon the semi-fluid mass of cinder and slag, and tend to promote clogging about the tuyeres while keeping it open above the tuyeres; while blast from a non-positive blower would percolate, through small openings in the mass, and be more effective than a large volume of blast from a positive blower forming large openings in it through which it escaped into the cupola?

These are questions we have frequently tried to solve by actual test; but it is so difficult to find two cupolas of the same dimensions melting the same-sized heats for the same class of work, one with a positive and the other with a non-positive blast, that we have never been able to test the matter. We have melted iron with nearly all the blowers now in use and with a number of the old-style ones, and think there is more in the management of a cupola than there is in a positive or non-positive blast. Good melting may be done with either of them, when the cupola is properly managed, and it cannot be done with either of them when the cupola is not properly managed. Until the management of cupolas in every-day practice is reduced to more of a system than at present, it will be impossible to determine any practical advantage in favor of either blower over the other. So far as we are concerned, we have no preference in blowers, but make it a rule to charge a cupola more openly when melting with a non-positive blast, for the reason that stock may be packed so closely in a high cupola, that the

volume of blast that is permitted to enter at the tuyeres may not be reduced by preventing its escape through the stock.

The amount of air that is required for combustion of the fuel in melting a ton of iron has been determined by accurate experiments to be about 30,000 cubic feet, in a properly constructed cupola in which the air was all utilized in combustion of the fuel. This amount of air if reduced to a solid would weigh about 24,000 lbs., or more than the combined weight of the iron and fuel required to melt it. In a cupola melting ten tons per hour, 300,000 cubic feet of air must be delivered to the cupola per hour to do the work. It will thus be seen, that a very large volume of blast is required in the melting of 10 tons of iron. To deliver this amount of air to a cupola from a blower that is capable of producing it in the shape of a blast, the blast pipes must be arranged in such a way that the velocity of the air is not impeded by the pipes; and the tuyeres must be of a size to admit the air freely to the cupola. This is not always the case, for we have seen many cupolas in which the combined tuyere area was not more than one-half that of the blower outlet. The object in making the tuyere area so small was to put the air into the cupola with a force that would drive it to the centre of the stock. This was the theory of melting in the old cupolas with small tuyeres, but this was wrong, for air cannot be driven through fuel in front of a tuyere, as an iron bar could be forced through it, even with a positive blast; and when the air strikes the fuel it cannot pass through it, but escapes through the crevices between the pieces of fuel. These crevices may change its direction entirely, and the same force that drives it into the cupola impels it in the direction taken, which will be the readiest means of escape, and is more liable to be up along the lining than toward the center of the cupola. For, as a rule, stock does not pack so close near the lining as toward the center, and the means taken to prevent the escape of blast around the lining is the very thing that causes it to escape in that way. Since blast cannot be driven through fuel to the center of a cupola and can only escape from the tuyeres

through the crevices between the pieces of fuel, the only way to force it to the centre of a cupola is to supply a sufficient volume of blast to fill all of the crevices between the pieces of fuel. This can only be done by discarding the small tuyeres and using a tuyere that will admit blast freely to a cupola.

In placing tuyeres in a cupola, it must be remembered that the outlet area of a tuyere is governed by the number of crevices between the pieces of fuel in front of the tuyere through which the blast may escape from the tuyere. With small tuyeres a large piece of fuel may settle in front of the tuyere in such a way that the tuyere outlet is not equal to one one-hundredth part of the tuyere area, in which case the tuyere is rendered useless, and may remain useless throughout the heat. For these reasons small tuyeres should never be placed in a cupola. For small cupolas we should recommend the triangular tuyere, Fig. 14, for the reason that it tends to prevent bridging, and its shape is such that it is less liable to be closed by a large piece of fuel than a round tuyere of equal area. The vertical slot tuyeres, Figs. 10 and 11, are also for the same reason good tuyeres for small cupolas.

For large cupolas we think the expanding tuyere, Fig. 3, is the best, and if we were constructing a large cupola we should use this tuyere in preference to any other, and make the outlet at least double the size of the inlet, and should place the tuyeres so close together that the outlets would not be more than six or eight inches apart. This would practically give a sheet blast, and distribute air evenly to the stock all around the cupola. The width of the tuyere can be made to correspond with the diameter of cupola, and may be from three to six inches, and should be of a size that will permit blast freely to enter the cupola. Parties who have been melting with small tuyeres and put in large ones upon this plan, must change their bed and charges to suit the tuyeres, for this arrangement of tuyeres would probably be a complete failure in a cupola charged in the same way as when not more than one-fourth of the blast supplied by the blower entered the cupola.

The largest cupolas in which air can be forced to the center from side tuyeres with good results would appear from actual test to be from four and a half to five feet. Larger cupolas than this have been constructed, and are now in use, but they do not melt so rapidly in proportion to their size as those of a smaller diameter. To illustrate this, we might cite the Jumbo Cupola of Abendroth Bros., Port Chester, N. Y., already described, in which the diameter at the tuyeres is 54 inches, and above the bosh 72 inches, in which 15 tons of iron have been melted per hour for stove-plate and other light castings.

The Carnegie Steel Works, Homestead, Pa., have cupolas of seven and one-half feet diameter at the tuyeres and ten feet diameter above the bosh, in which the best melting per hour is only fourteen tons. The area of this cupola at the tuyeres is almost three times that of Abendroth's cupola, yet the amount of iron melted per hour is actually less than that of the smaller cupola. Tuyeres have been arranged in different ways in this large cupola, and from one to four rows used, yet the melting was not in proportion to the size of cupola. This would seem to indicate that the cupola was not properly supplied with blast near the centre, and the melting done in the center was caused principally by the heat around it; which is probably the case, for the cupola is kept in blast night and day, for six days, and melting must take place in the centre, or the cupola would chill up.

There are many cupolas of sixty inches diameter at the tuyeres in use in which good melting is done, but this would seem to be the limit at which good melting takes place in a cupola supplied with blast from side tuyeres, for above this diameter the rapidity of melting does not increase in proportion to the increase in size of cupola.

There has been considerable experimenting done during the past two or three years with a center blast tuyere for admitting blast to the center of a cupola through the bottom. We have had no practical experience with this kind of tuyere for the last twenty-five years, when we placed one in a small cupola with

side tuyeres and found no advantage in it; probably for the reason that a sufficient quantity of air for an even combustion of the fuel was supplied to the centre of the cupola from the side tuyeres.

During the past few years, we have visited a number of foundries in which the center blast was being tried, but in every case the tuyere was out of order or not in use at the time of our visit. The great objection to this tuyere seems to be its liability to be filled with iron or slag and rendered useless. Should this objectionable feature be overcome, it would certainly be a decided advantage in melting in cupolas of large diameter in connection with side tuyeres. In cupolas of small diameter with side tuyeres, we do not think a center blast would increase the melting capacity of a cupola, for the reason that air can be forced to the center of a small cupola from side tuyeres, when properly arranged and of a proper size.

With a center blast alone, it is claimed that considerable saving is effected in lining and fuel. It is reasonable to suppose that a saving in lining might be affected by a center blast; for the most intense heat that is created by the blast is transferred from near the lining to the center of the cupola, and the tendency to bridge is greatly reduced. As to the saving of fuel, there never was a new tuyere that did not "save fuel," and there have been hundreds of them, but consumption of cupola-fuel is still too large.

CHAPTER XXI.

BLOWERS.

TO describe and illustrate all the blowing apparatus designed for furnishing blast for cupolas would require a larger volume than this one is designed to be, and would be of little practical value, as founders are not looking for obsolete but up-to-date machinery. We shall therefore confine ourselves to a description of a few and most improved blowers.

The blowers used for this purpose at the present time are confined almost exclusively to two types, viz., *Rotary Pressure Blowers* and *Fan Blowers*. Each of these types has its advocates, and both are extensively used in supplying cupola blast. That they may be employed for this purpose is clearly demonstrated by the many hundreds of each type now in use.

The question of superiority of one type over the other for furnishing cupola blast is one that has been extensively discussed, and for which extravagant claims have been made by the manufacturers of each, and proved by them to their own satisfaction and in many cases to the satisfaction of their patrons; and where such claims can be proved by the manufacturers of each type, there must be some good points in each.

We have melted iron in all the various styles of cupolas now in use, and in many of the old styles that have gone out of use with both these types of blowers, and have also seen a good deal of melting done with them, and are of the opinion that as fast and economical melting can be done with one type as with the other, when a cupola is properly managed; and good melting cannot be done with either one of them if a cupola is not properly managed. It is just as well to have the blast shut off by the settling of stack and clogging of the cupola as

is claimed to occur with a fan blower, as it is to force blast into a cupola when in this condition, as can be done with a pressure blower. For in such cases, the blower if of a proper size is not responsible for this condition of the cupola, and when in this condition good melting cannot be done with either blower. The selection of a blower is therefore a matter to be decided by each founder, and the points to be considered are, which is the most economical blower under the conditions in which it is to be placed.

THE GREEN PATENTED POSITIVE PRESSURE BLOWER.

This is a blower of a new design recently placed upon the market by the Wilbraham-Baker Blower Co., to take the place of the Baker blower, for many years manufactured by them. The new blower is said to be a great improvement upon the Baker blower, which for many years was one of the best in use for foundry cupolas.

We regret that the descriptive matter of the Green Blower was not ready in time for this work, and we are unable to give a detailed description of its construction and advantages for cupola work.

CONNERSVILLE CYCLOIDAL BLOWER.

The Connersville Positive Pressure Blower is one of the latest designs of blower, and has only been manufactured for a few years. A description of it is taken from the excellent circular, which is well worth reading by those contemplating the purchase of pressure blowers, and is as follows:

The cycloidal curves, their nature, peculiarities and possibilities, have always been an attractive study, not only to the theoretically inclined, but more particularly to those interested in the many important applications of these curves in practical mechanics. The especial value of combining the epi- and hypocycloids to form the contact surfaces of impellers for rotary blowers, gas exhausters and pumps has long been recognized, and many attempts have been made to utilize them in that connection, but in vain. While conceded to give the theoretically

correct form to a revolver or impeller, it came to be regarded as impossible to produce such surfaces by machinery with sufficient accuracy to admit of their use in practice with any degree of satisfaction. It remained for us to demonstrate that it could be done, and in a highly successful manner as well.

Fig. 62 is an illustration showing a cross section of our new cycloidal blower, and particularly of the revolvers or impellers, their form, relation to each other, and to the surrounding case. A glance only is required to discern the superiority of this method of construction over all others.

The vital part of every machine of this class is the impeller,

FIG. 62.

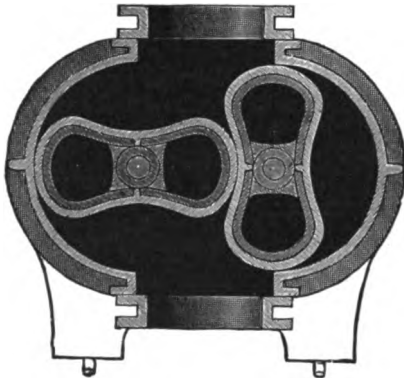

SECTIONAL VIEW OF CONNERSVILLE CYCLOIDAL BLOWER.

as on it depends economy of operation and efficiency in results. That we have the ideal form for an operating part is self-evident. It will be noted that there are two impellers only, and each is planed on cycloidal lines with mathematical accuracy. Now, it is one of the well-known peculiarities of the epi-cycloidal and hypo-cycloidal curves, when worked together as in our machines, that there is a constantly progressive point of contact between the impellers. As a result of this regular advance of the point of contact, the air is driven steadily forward, producing a smooth discharge that is conducive to the highest economy.

The advantage of this arrangement over the use of arcs of

circles to approximate contact curves is very great, as it is a well-demonstrated fact that circular arcs whose centers are not co-incident with the centers of revolution can not keep practical contact through an angle of more than four or five degrees. On the contrary, the contact does not progress continuously, but jumps from one point to another across intervening recesses as the impellers revolve, leaving pockets in which the air is alternately compressed and expanded, producing undesirable pulsations in the blast, a waste of power, and necessitating two points of contact at one time in four positions in each revolution.

Another advantage of the cycloidal form is that, at the point of contact, a convex surface is always opposed to a concave surface; that is, the epi-cycloidal part of one impeller works with the hypo-cycloidal part of the opposite impeller. The consequence of this is to produce a *long contact* or distance through which the driven air must travel to get back between the impellers, instead of the short contact that results when two convex surfaces oppose each other, as is the case in other machines of this character.

Attention has previously been directed to the fact that the point of contact between the impellers continuously progresses; indeed, the path it describes is a circle. One result of this continuously-progressive contact, as before mentioned, is a smooth, reliable blast. Another is, as has also been noted, the absence of any pockets or cavities in which air can be gathered, compressed and then discharged back toward the inlet side of the machine, thereby entailing a waste of power and shortening the life of the blower by subjecting the impellers, shaft and gears to a needless shock, strain and wear. Furthermore, the impellers can be in contact only at one point at the same instant—in no position is it possible for them to touch each other at two points at once; hence, there are no shoulders to knock together when the speed is more than nominal.

On account, also, of there being no popping due to the expansion of air when released from the pockets in which it has been caught and compressed, and no pounding of the impellers

together, that disagreeable din and vibration usually associated with machines of this class is eliminated, and our blowers run with practically no noise. This is a feature that will commend itself to parties having had experience with other pressure blowers.

Another point contributing to the evenness and uniformity of the discharge is the fact that the extremities of the impellers are curved. Thus, as they sweep past the outlet, there is a gradual equalization of the pressure instead of a sudden shock, such as results from the passage of two sharp edges, which shocks are so detrimental to all working parts, as has been noted.

From what has been stated, we scarcely need to add that the machine is positive in its action. All the air that enters the blower is inclosed by the impellers, forced forward and discharged through the outlet pipe. The leakage is insignificant, and there is no compressed air allowed to escape backward. Hence, all the power applied to the machine is used for the purpose intended—the maintenance of an even blast—and none of it is wasted on needless work.

Furthermore, as the contact between the impellers and the surrounding case is perfect at all times, the amount of pressure that can be developed and sustained depends solely on the strength of the machine and the power applied.

Each of the two impellers is cast in one piece and well ribbed on the inside to prevent changes in form under varying conditions. It is part of our shop practice to press the shaft into the impeller with a hydrostatic press, finish the journals to standard size, mount the impeller on a planer and *plane its entire surface accurately*. By this means we secure perfect symmetry and exactness with respect to the journal on which it revolves, and, as a consequence, can produce a machine that will run more smoothly, and in either direction, at a higher speed and pressure than it has been possible to attain heretofore.

It will be observed that the cycloidal curves produce an impeller with a broad waist. We have availed ourselves of this to use a high-grade steel shaft of about *twice the sectional area*

of those found in competing machines. The advantages of this need not be enumerated.

In Fig. 63 we illustrate the style of blowers that are most largely sold, *i. e.*, those pulley driven. It will be noticed that we use one pulley only. We can, however, when desired, put a pulley on each end, but because of the large shafts, wide-faced gears, and the fact that there is a bearing the entire distance from

FIG. 63.

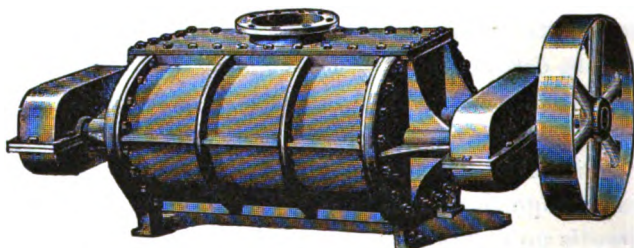

HORIZONTAL BLOWER.

the gears to the impellers, it is seldom necessary. In any event, we do not recommend two belts very highly, as, owing to the difference in the amount of stretch in the leather, it is usually the case that one transmits most of the power. Indeed, it sometimes occurs that they work against each other.

NUMBERS, CAPACITIES, ETC., OF THE CYCLOIDAL BLOWERS.

NUMBER OF BLOWER.....	$\frac{1}{4}$	$\frac{1}{2}$	1	2	3	4	5	6	7	8
Capacity in cubic feet per revolution.....	$\frac{2}{3}$	$1\frac{1}{2}$	3	$5\frac{1}{4}$	8	$12\frac{1}{2}$	$24\frac{1}{2}$	42	67	100
Ordinary speed.....	400	350	300	275	250	200	175	150	125	100
Diameter of pipe opening ...	4	6	8	10	12	14	16	20	24	30

By "ordinary speed" we mean what would be about an average of every-day duty. It must be understood, however, that the peculiar form of the impellers of our blowers, in connection with the other superior points in construction to which we have called attention, permits of higher speeds than competing machines.

The speed at which positive pressure blowers are run may be classed as "slow;" therefore, power can be taken direct from the main line of shafting or from a countershaft driven at the same rate.

Fig. 64 shows a blower with an engine to furnish the required power, both on the same bed-plate. By such a combination all shafting, pulleys, gears and belts are dispensed with, as the crank shaft of the engine is coupled direct to a shaft of the

FIG. 64.

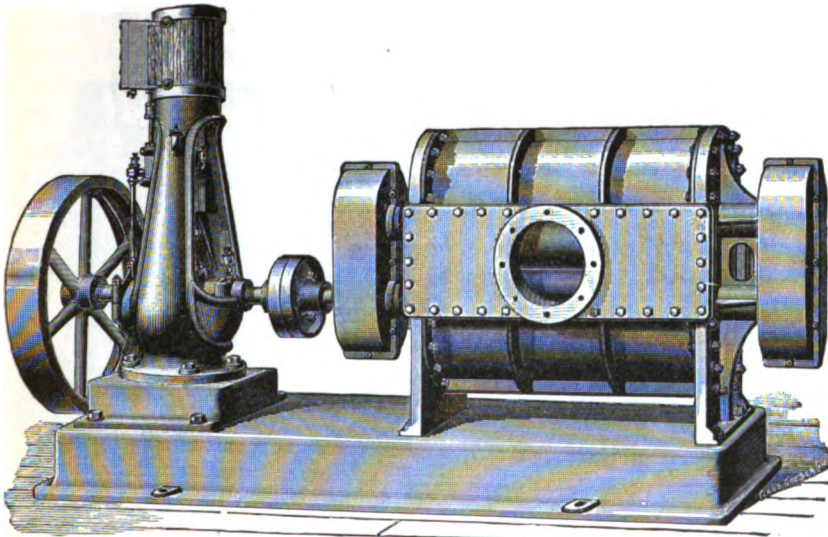

VERTICAL BLOWER AND ENGINE ON SAME BED-PLATE.

blower, thereby effecting a very simple but most efficient driving arrangement. We recommend the installation of such a plant when the blower is to be located at a considerable distance from the line shaft, as it will be found more economical to pipe steam to the engine than to transmit power by shafting or cable. But even where power is convenient there are many good reasons why it will be found much more desirable to operate the blower with its own engine. For instance, it can be run independent of the other machinery, as necessity or convenience may often

require, and also permits the speed of the blower to be varied as there is a demand for an increased or diminished amount of blast, while otherwise this could not be accomplished without a change of pulleys.

In nearly every town there is now a station for electric-lighting purposes, and managers of it are finding that they can extend the earning capacity of their plants and increase their profits by renting power at a time when otherwise their machinery would be practically idle. We have arranged to have our machines operated by electric motors when desired. In

FIG. 65.

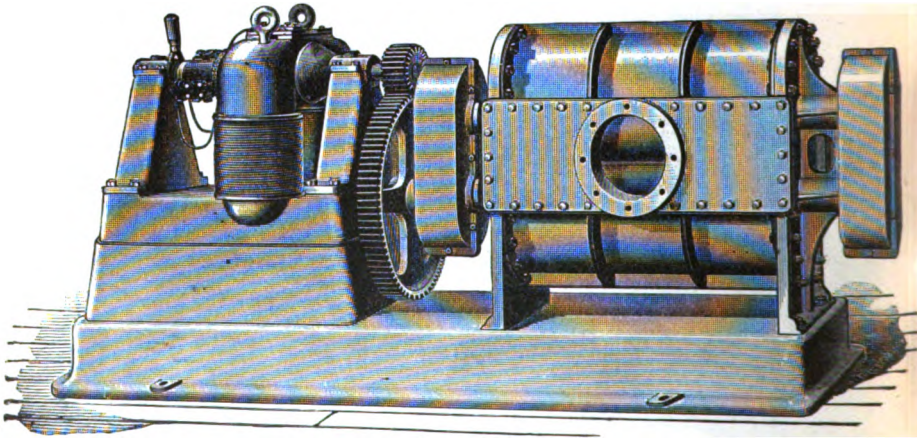

BLOWER AND ELECTRIC MOTOR.

Fig. 65 will be found an illustration of a motor geared direct to a blower, both on the same bed plate. When preferred, however, the motor can be located a short distance away, and the power transmitted to the blower pulley by means of a belt, Foundries and other industries needing power only to run their blowers will find it exceedingly advantageous and economical to adopt this plan. Not only will there be a saving in first cost, but the operating expense will be much less.

Furthermore, the motors can have sufficient power to run the rattler and other light machines about the establishment.

ROOT'S ROTARY PRESSURE BLOWERS.

In the latest improvements in the construction of these blowers, the manufacturers assert that they represent the up-to-date developments in this class of machinery, because with an experience of forty years in the construction of rotary pressure blowers, their improvements mean that they adapt and adopt such features as will meet the requirements of the trade, and at the same time eliminate what their long experience teaches them would be objectionable in the construction of this class of machinery.

They claim that their machines represent the best class of workmanship, material and design, the highest efficiency, the

FIG. 66.

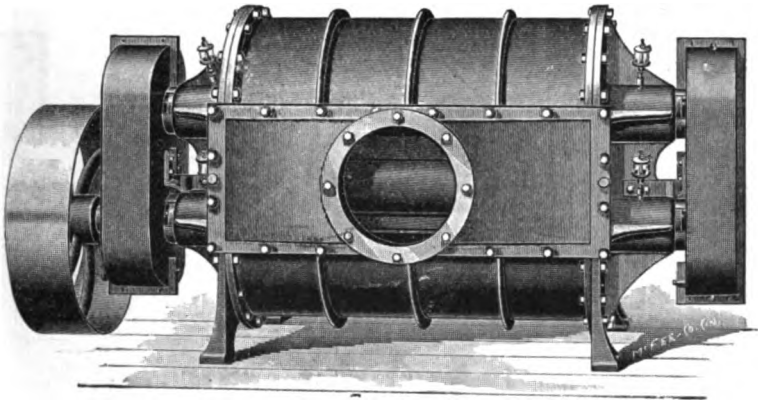

ROOT'S VERTICAL PRESSURE BLOWER.

greatest durability, and a *positive guarantee* that a given quantity of air under a given pressure will be delivered with less power than any competitive machine.

In the most recent constructions the shape of the blower cases has to some extent been changed, and they are now constructed vertical and horizontal as shown in Figs. 66 and 67. They are also made with blower and engine on same bed-plate or with blower and electric power motors on same bed-plate. The following claims are made for it by the manufacturers:

1. It is simpler than any other blower.
2. It is the only positive rotary blower made with impellers constructed on correct principles.
3. It is the best, because it has stood the test of years and is the result of long experience.
4. In case of wear of the journals, the impellers will not come together and break, or consume unnecessary power, as is the case with competing machines.
5. The principles upon which our blowers are constructed admit of more perfect mechanical proportions than any other.
6. The only perfectly adjustable journal box for this type of machine is used.

FIG. 67.

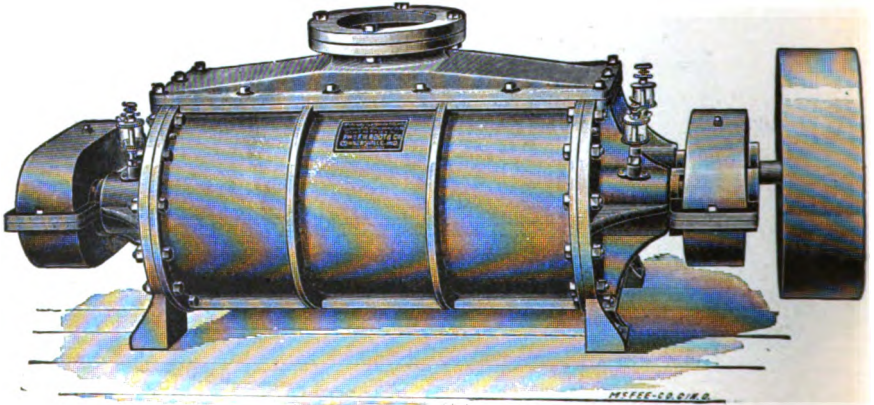

ROOT'S HORIZONTAL PRESSURE BLOWER.

7. The gears are wide-faced and run constantly in oil.
 8. The gears and journals are thoroughly protected from dust and accident.
 9. Our machine blows and exhausts equally well and at the same time, and the motion may be reversed at any time.
 10. All the operating parts are accurately balanced.
- The principles upon which our blower is constructed are so radically different from any competing machine that we are enabled to adopt proportions that are mechanically perfect, and

hence we can speed our machines much faster than any other, with a far greater degree of safety. We are not compelled to cut down the weight of our blower cases, as other manufacturers do, in order to bring the weight of the complete machine within reasonable bounds. The distribution of metal in the shafting, impellers, gears and cases of all our blowers is perfectly proportioned, and it is the only rotary positive blower made so constructed.

GARDEN CITY POSITIVE BLAST BLOWERS.

In Fig. 68 is shown the Garden City Positive Blast Blower, manufactured by the Garden City Fan Co., Chicago, Ill., many

FIG. 68.

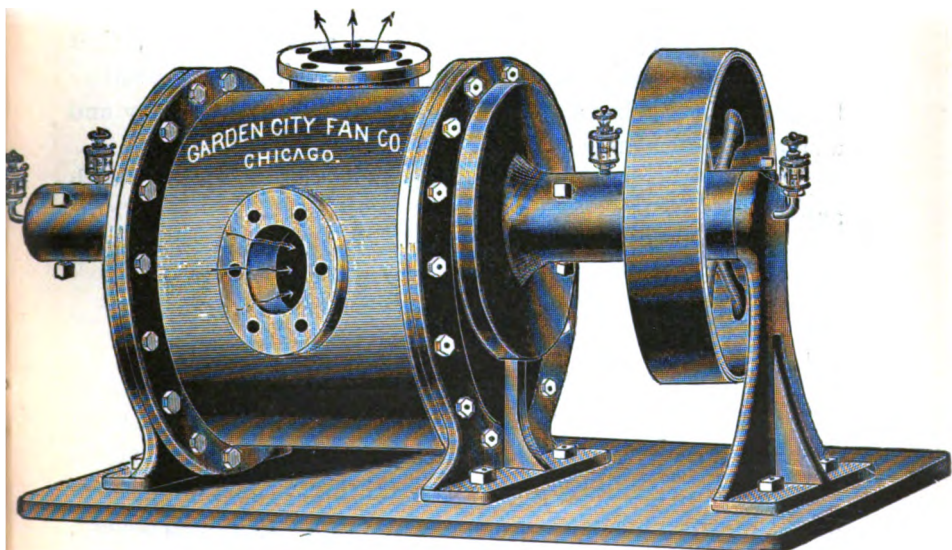

GARDEN CITY POSITIVE BLAST BLOWER.

of which are in use in foundries, and for which claims are made as follows:

The operation of our blower is not on the fan principle, in which pressure is obtained by a high velocity or speed, but when the air enters the case at the inlet and is closed in by the

vanes of the blower, it is absolutely confined and must be forced forward until finally released at the outlet, where it must have escape or the blower stop if outlet is closed. There is positively no chance for loss by backward escapement of air, after it once enters the inlet.

In many respects our blower has points of superiority over any positive blower made, and we call your attention to the following points:

1st. It has no gears whatever. No internal parts that require attention, adjustment or lubrication.

2d. It has only two journal bearings that are external to the blower casing. They are self-oiling. Easy of adjustment.

3d. Has no irregular internal surfaces that require contact to produce pressure, and add friction.

4th. Operating parts are always in perfect balance, thus blower may be safely run at a higher speed than any positive blower made, giving a proportionate increase in efficiency and a smaller blower may be used.

5th. A higher pressure can be obtained than is possible with any other.

6th. The blowers are practically *noiseless* as compared with all other makes.

FAN BLOWERS.

The Sturtevant Blowers.

A third of a century has elapsed since the Sturtevant Steel Pressure Blower was first introduced as an indispensable factor in many manufacturing processes. Of the greatest importance has been its influence upon cupola practice. Before its advent, the rotary blower and the blowing engine were the only devices available for the production of blast sufficient for the melting of iron. It was at once asserted that a fan blower could not create sufficient pressure, was less efficient and less serviceable than the rotary blower. But Mr. Sturtevant, with characteristic energy and zeal, soon disproved these statements, made the fan an active competitor, and soon the worthy successor of the

rotary blower; and all this because the merits of the fan were emphatically proven, clearly presented and readily appreciated.

STEEL PRESSURE BLOWERS.

Although these blowers were originally designed for use in connection with cupola furnaces and forges, they are equally efficient when employed for producing mechanical draft for steam boilers, where high air pressure is required in connection with mechanical stokers, for producing the blast in sand blast

FIG. 69.

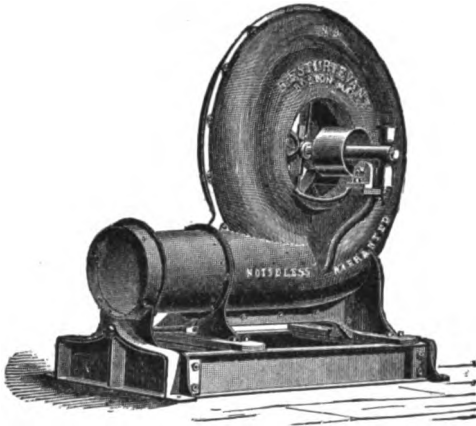

machines, for use in connection with pneumatic tube delivery systems, and in fact for any purpose where high pressure is to be maintained or where air or gas is to be forced long distances.

The shell (Fig. 69) is of cast iron, bolted together and provided with an outlet. The shaft is of high-grade steel, carefully finished, and the wheel and boxes are as described on a succeeding page.

Number of Blower.	Outside Diameter of Outlet in Inches.	Diameter and Face of Pulley, in Inches.	Weight, in Pounds.	
			Not Packed.	Packed.
0000	2 $\frac{3}{4}$	1 $\frac{7}{8}$ x 1 $\frac{3}{8}$	17	35
00	3 $\frac{1}{2}$	2 $\frac{5}{8}$ x 1 $\frac{7}{8}$	35	65
0	4	3 x 2 $\frac{1}{8}$	55	90
1	4 $\frac{7}{8}$	3 $\frac{1}{2}$ x 2 $\frac{1}{8}$	75	100
2	5 $\frac{3}{8}$	3 $\frac{3}{8}$ x 2 $\frac{3}{8}$	95	140
3	6 $\frac{1}{4}$	4 $\frac{1}{2}$ x 3	155	220
4	7 $\frac{3}{8}$	5 x 3 $\frac{1}{2}$	225	310
5	8 $\frac{7}{8}$	5 $\frac{3}{4}$ x 4	330	395
6	10 $\frac{1}{4}$	6 $\frac{3}{4}$ x 4 $\frac{1}{2}$	460	500
7	12	7 $\frac{7}{8}$ x 5 $\frac{3}{4}$	695	740
8	13 $\frac{7}{8}$	9 $\frac{1}{8}$ x 6 $\frac{1}{4}$	870	920
9	16	10 $\frac{1}{8}$ x 8	1,615	1,680
10	18 $\frac{1}{2}$	12 $\frac{5}{8}$ x 9 $\frac{3}{4}$	2,100	2,175

STEEL PRESSURE BLOWERS ON ADJUSTABLE BED WITH COMBINED
UPRIGHT ENGINE.

This type of machine (Fig. 70) represents the acme of convenience and economy. It may be shipped ready for immediate operation and may be used in any location to which a steam pipe can be conducted. The merits of the adjustable bed have already been pointed out. Its combination with an upright engine insures perfect alignment, rigidity, ease in adjustment, perfect control over the tension of belts, and, when desirable, an instantaneous change in the speed of the blower independently of any portion of the plant.

Both of the styles of the engines employed are identically the same in design, workmanship and material as the regular automatic engines. The double enclosed upright engine is peculiarly fitted for this service. All the running parts are thoroughly protected from the dust that forms an inherent part of the atmosphere in or about any foundry or forge shop. The oil-cups are all placed upon the exterior of the frame, so that continuous oiling is possible without the repeated opening and

closing of the door. The short stroke, the perfect balance of the reciprocating parts and the large wearing surfaces make

FIG. 70.

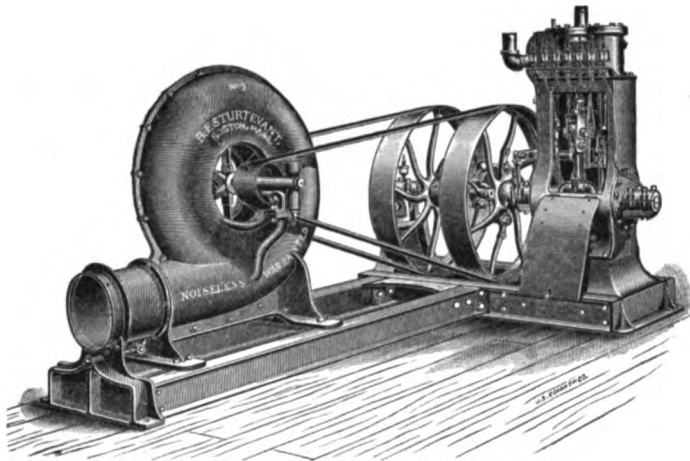

high rotative speed possible and render this engine unexcelled for the purpose for which it is designed.

Number of Blower.	4 to 8 oz. Pressure.				8 to 12 oz. Pressure.			
	Style of Engine.	Diameter of Cylinder.	Stroke.	Weight in Pounds.	Style of Engine.	Diameter of Cylinder.	Stroke.	Weight in Pounds.
4	Single Upright.	4	4	1,300	Double Enclosed Upright.	4	3	1,650
5		5	5	1,750		5	4	2,100
6		6	6	2,300		6	5	3,500
7		7	7	3,650		6	5	4,050
8	Double Enclosed Upright.	6	5	5,500	Double Enclosed Upright.	7	5	5,400
9		6	5	6,300		7	5	6,400
10		7	5	7,950		8	5½	8,600

ELECTRIC STEEL PRESSURE BLOWERS.

Electric blowers of this type are obviously applicable for all purposes for which the ordinary form of steel pressure blower

may be employed. The fact that in the case of blowers with direct-connected motors it is possible to place them wherever most convenient, and then make connection by wire, is most suggestive of their universal adaptability. All connecting belts and shafting, or the presence of a special engine and the necessary steam piping, are thus avoided. The blower is usually readily portable, and therefore easily adapted to changed conditions. The electric steel pressure blowers are principally used for the blowing of forge fires and cupola furnaces,

FIG. 71.

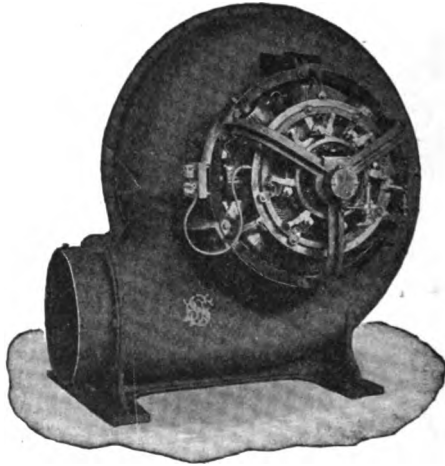

although equally serviceable for any work for which the regular type is adapted.

The general construction of these blowers is evident from the accompanying illustration, Fig. 71.

In the smallest sizes the motor is of the bi-polar type, circular in form, extremely compact and attached directly to the side of the blower, which is otherwise perfectly regular in its character.

Where the atmosphere is free from dust, the open type may be employed. Otherwise, the enclosed construction is preferable. This is especially designed for foundry work, and may

be introduced in either of two forms. That is, the motor may be adjustably attached to the fan; or the motor, with its enclosing ends, may be independently mounted, and the fan attached in such manner that it may be turned to discharge in any direction.

The largest sizes of electric steel pressure blowers are equipped with multi-polar motors of the independent circular type. This form of motor is placed upon a high bed, which in connection with the fan to which it is bolted serves as an extremely solid foundation.

In the belted arrangement the same type of motor is employed. This form of construction is desirable where the speed of a direct-connected motor would of necessity be excessive, or where for certain reasons such an arrangement would be undesirable.

Different sized motors may be fitted to the same blower, thereby making possible a great number of combinations, with speeds and capacities dependent upon the current and the size of the motor. These electric blowers are regularly made bottom horizontal discharge, but may be made to discharge either upward, downward, or horizontally at the top, when so ordered. In asking for estimate state clearly what work it is desired the blower should do, and give the voltage of the current available.

BUFFALO STEEL PRESSURE BLOWER.

In Fig. 72 is shown the latest improved construction form of the Buffalo Steel Pressure Blower, for cupola furnaces and forge fires. A distinguishing feature of this blower, common to those of no other manufacture of the same type, is the solid case, the peripheral portion of the shell being cast in one solid piece, to which the center plates are accurately fitted, metal to metal. It will thus be seen that the objectionable and slovenly "putty joint" is entirely dispensed with. Ready access to the interior of the blower, without entirely taking it apart, is also thus afforded. With blowers of other manufacture, the "putty

joint" feature of the shell or casing is an indispensable adjunct, although it is a construction point which is, at the best, something to be avoided in an efficient machine.

The Buffalo Steel Pressure Blower is designed and constructed especially for high pressure duty, such as supplying blast for cupolas, furnaces, forge fires, sand-blast machines, for any work requiring forcing of air long distances, as in connection with pneumatic tube delivery system. It is adapted for all uses where a high pressure or strong blast of air is re

FIG. 72.

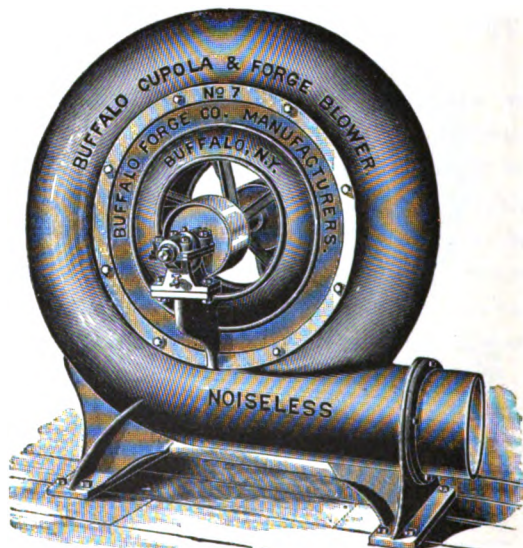

STEEL PRESSURE BLOWER.

quired. The journals are long and heavy, in the standard ratio of length to diameter of six to one, and embody a greater amount of wearing surface than those upon the blower of any other construction. Attention is directed to the patented journals and oiling devices employed on this blower, which are unique features. The bearings are readily adjustable, and any wear can be taken up, which is an important point attending the durability and quiet running of a perfect machine.

The Buffalo Steel Pressure Blower possesses the fewest number of parts of any like machine; in fact, the blower is practically one piece, so that under any service the bearings invariably are in perfect alignment, vertically and laterally, with the rest of the machine. In the items of durability, smooth running and economy of power, it is thus rendered far superior to any blower with the so-called universal journal bearing which is commonly employed.

In every point of construction the greatest pains have been taken to simplify all parts, and at the same time to give them the greatest strength. To adjust, repair and keep in order a Buffalo Blower is a very small matter and readily understood by a machinist of average ability.

For obtaining the best results from a blower of given size, when used for melting iron in foundry cupolas, much depends upon the proper lay-out of the blast piping between the blower and the cupola, and also upon the proper proportionment, arrangement and design of the cupola tuyeres. Several forms of cupolas are now upon the market, economical in the use of fuel and fast melting, which are the points most sought for in cupola construction. It is a common but erroneous idea that a blower large for the work will give better results, in a given diameter of cupola, than a smaller one. In the tables which accompany the blower, we give the proper sizes of blower for different diameters of cupolas; but it must be borne in mind, that if the tuyerage is not of sufficient area, or if the blower has to be located at some distance from the work to be accomplished, these points enter for consideration. Frequently, foundrymen, when experiencing difficulty in obtaining satisfactory melts, throw the whole cause of the trouble upon the blower, when the fault does not lie at this point. It is safe to say that failures are due more largely to the mismanagement of a cupola and improper application of the blower, than to any other cause.

The Buffalo Steel Pressure Blower is especially adapted for foundry cupolas, and is guaranteed to produce stronger blast with less expense for power, than any other.

BLOWER ON ADJUSTABLE BED, AND ON BED COMBINED WITH COUNTERSHAFT.

Unless considerable care is taken in putting up countershafts, and some special attention is given to keep them in perfect alignment, trouble is often experienced, especially in keeping the belts on the larger sizes of blowers, on account of the great speed at which they have to run to produce high pressures. To overcome such features, this house designed the adjustable bed, and the adjustable bed combined with countershaft arrangements, which is illustrated in Fig. 63. The blower on adjustable bed, alone, without the countershaft, is very con-

FIG. 73.

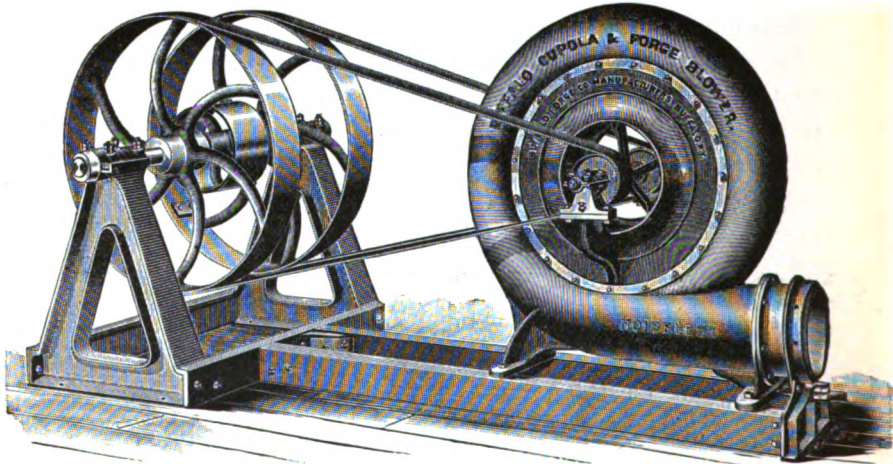

BLOWER AND COUNTERSHAFT.

venient for taking up the slack in belts while the fan is in motion and driven by belt from main line.

In Fig. 73 is shown the latest construction form of Buffalo Steel Pressure Blower on adjustable bed with combined countershaft. Its use will be found to result in a decided saving in the wear and tear upon belts, which, in a short time, more than justifies the extra initial expense of the arrangement. The cost will be found little in excess of ordinary method, and a few turns of the nut on the end of the adjusting screw, which is

clearly shown directly under the outlet of the blower, after first unloosening the holding-down bolts, which should afterward be re-tightened, accomplish, in a very few moments, what, previous to the introduction of this apparatus, has caused considerable delay and annoyance. It will readily be seen that the usual frequent relacing of belts, to make them sufficiently tight to avoid slipping, is hereby entirely obviated.

Positive alignment of the countershaft with the shaft of the blower by this arrangement causes the belt to track evenly, run smoothly and avoid the usual wear by their striking against the hanger or side of the blower. As will be readily appreciated, the tightening screw gives the same uniform tension to both belts, and this may be regulated at will of operator. A telescopic mouth-piece, as is shown by the cut, is placed upon each blower purchased in this form, which enables the machine to be moved upon its bed without any disarrangement of the blast piping.

Especial attention is called to the fact that the arrangement of blower on adjustable bed combined with countershaft, as illustrated in Fig. 63, occupies the smallest amount of space consumed by any apparatus of this kind manufactured in the world. Ordinary tight and loose pulleys are placed upon the countershaft from which the power is transmitted to the countershaft of this apparatus. When this feature is not desirable, which is often the case where power is transmitted from the main line without the intervention of a countershaft, the adjustable bed countershaft may be furnished with the blower, so that it will extend at the right or left, as desired, and the tight and loose pulleys are then placed thereon; we then have a right or left hand apparatus. The space between the two pulleys which drive the blower is not wide enough to permit of the introduction of tight and loose pulleys.

BUFFALO BLOWER FOR CUPOLA FURNACES IN IRON FOUNDRIES.

In the following table are given two different speeds and pressures for each sized blower, and the quantity of iron that

may be melted per hour with each. In all cases, we recommend using the lowest pressure of blast that will do a given work. Run up to the speed given for that pressure, and regulate the quantity of air by the blast gate. The proportion of tuyerage should be at least one-ninth of the area of cupola in square inches, with not less than four tuyeres at equal distances around cupola, so as to equalize the blast throughout. With tuyeres one-twentieth of area of cupola, it will require double the power to melt the same quantity of iron, and the blast will not be so evenly distributed. Variations in temperature affect the working of cupolas very materially. Hot weather requires an increase in volume of air to melt same quantity of iron as in cold weather.

TABLE OF SPEEDS AND CAPACITIES AS APPLIED TO CUPOLAS.

Number of Blower.	Square Inches Blast.	Diameter Inside of Cupola in Inches.	Pressure in Ounces.	Speed—No. of Revs. per Minute.	Melting Capacity in Lbs. per Hour.	Cubic Feet of Air Required per Minute.	Pressure in Ounces.	Speed—No. of Revs. per Minute.	Melting Capacity in Lbs. per Hour.	Cubic Feet of Air Required per Minute.
4	4	20	8	4732	1545	666	9	5030	1647	717
5	6	25	8	4209	2321	773	10	4726	2600	867
6	8	30	8	3660	3093	951	10	4108	3671	1067
7	14	35	8	3244	4218	1486	10	3642	4777	1668
8	18	40	8	2948	5425	2199	10	3310	6082	2469
9	26	45	10	2785	7818	3203	12	3260	8598	3523
10	36	55	10	2195	11295	4938	12	2413	12378	5431
11	45	65	12	1952	16955	7707	14	2116	18357	8358
11½	55	72	12	1647	22607	10276	14	1797	25176	11144
12	75	84	12	1647	25836	11744	14	1797	28019	12736

CHAPTER XXII.

CUPOLA SCRAPS.

BRIEF PARAGRAPHS ILLUSTRATING IMPORTANT PRINCIPLES.

Make a heat, take a heat, make a cast, make a mould, run a melt, casting, moulding, are all terms used in different sections of the country to indicate the melting of iron in a cupola for foundry work.

When iron runs dull from a cupola, draw all the melted iron off at once and prevent the newly melted iron being chilled by dropping into dull iron in the bottom of the cupola.

When slag flows from a tap-hole with a stream of iron, when the iron is not drawn off too close, it is due to too much pitch in the sand bottom.

The formation of slag in a spout is due to poor material used in making up the spout.

Some foundrymen do not seem to know what hot iron is, for they call all kinds of B. S. hot iron if it will run out of the ladle.

The cutting out of the spout lining in holes by the stream of molten iron is due to a deficiency of cohesive properties in the lining material when heated to a high temperature.

When a tap-hole is closed up with slag and cannot be kept open, the slag is generally produced by the melting of the material used in making up the front and tap-hole. Slag made in the cupola flows from the tap-hole without clogging it.

A little sand or clay-wash added to the front and spout material will generally correct the deficiencies in the material and save the melter a great deal of trouble with his spout and tap-hole.

In a spout with a broad flat bottom the stream takes a differ-

ent course at every tap, the spout soon becomes clogged with cinder and iron, the molten iron flows in all directions, and the spout looks like a small frog pond with patches of scum. Make the bottom of the spout narrow and concentrate the stream in the center.

If the sand bottom does not drop readily when the doors are dropped, there is too much clay in the bottom material. Mix a little sand and cinder riddled from the dump with it, or some well-burnt moulding sand.

A hard rammed bottom causes iron to boil in a cupola the same as a hard rammed mould, and is frequently the cause of a bottom cutting through. A bottom should be rammed no harder than a mould.

Wet sand in a bottom not only causes iron to boil, but hardens it. Bottom sand should be no wetter than moulding sand when tempered for moulding.

Exclusively new sand should not be employed in making a bottom. The old bottom with a few shovels of sand riddled from the gangways makes the best bottom material.

Often a melter "don't know" why the cupola is working badly, because, if he knew, he would be discharged at once for carelessness.

A bad light-up makes a bad heat. The bed must be burned evenly, or it will not melt evenly.

If the wood is not all burned up before iron is charged, the wood smokes and the melter cannot see where to place the fuel and iron when charging. Never use green wood for lighting up. When green wood is used for lighting up, the bed is frequently burned too much before the wood is burned out, and the cupola is free of smoke.

Don't burn up the bed before charging the iron. When the fuel is well on fire at the tuyeres and the smoke is all burned off, put in the front, close the tuyeres and charge the iron at once.

If anything happens to delay putting on the blast after the fire is lighted, do not let that delay charging the iron, for the

bed will last longer with the iron on it than it will with it off. Charge the iron as soon as the bed is ready for charging; close the front and tuyeres and open the charging door to stop the draught, and the cupola may be left to stand for hours and as good a heat be melted as if no delay had occurred.

A melter who burns up his tapping bars so that two have to be welded together to make one almost every heat, don't know how to put in a front or make his bod stuff.

The amount of fuel wasted every year in the United States by the use of high tuyeres in cupolas is sufficient to make a man very rich.

A new cupola always effects a great saving in fuel, but it is often hard to find the fuel (saved) at the end of the year. A little more practical knowledge in managing the old cupola will often enable the foundryman to find the fuel saved and price of the new cupola besides.

Never run a fan in its own wind merely to show a high pressure on the air-gauge.

The volume of blast supplied to a cupola should be regulated by the speed of the blower and not by the size of tuyeres.

That old "no blast" story of the melter has had its day among practical foundrymen.

The air-gauges in use at the present time for showing the pressure of blast on a cupola are an excellent thing to prevent a poor melter from claiming he has no blast and blaming a bad heat on the engineer, for the gauge always shows a higher pressure of blast when the cupola is bunged up from poor management.

High tuyeres in a cupola are an inheritance left us by our forefathers in the foundry business, of which we have never got rid.

The only general improvement made in tuyeres in the past fifty years has been in increasing them to a size that will admit the blast freely to a cupola. The only local improvement has been in placing them lower.

Molten iron should be handled in a ladle and not held in a

cupola. Nothing is gained by holding iron in a cupola to keep it hot.

"I will let that go for to-day, and to-morrow I will take more time and fix it right," is a remark frequently made by melters. That kind of work is often the cause of a very bad heat.

Pig-iron melts from the ends, and the shorter it is broken the quicker it will melt.

Tin-plate scrap may be melted in a cupola the same as cast-iron. It throws off sparks from the tap-hole and spout similar to hard cast-iron.

The fins on castings made from tin-plate scrap must be knocked off with the rammer, for the castings are too hard and brittle to be chipped or filed.

The loss of metal in melting tin-plate scrap in a cupola is not so great as in melting iron when melted with a light blast, but the loss may be as great as 25 per cent. when melted with a very strong blast.

The cost of melting iron in a cupola is about two dollars per ton.

The cost of melting tin-plate scrap in a cupola is from three to four dollars per ton.

Galvanized sheet-iron scrap, when melted with tin-plate scrap, reduces the temperature of the molten metal to such an extent that it cannot be run into moulds.

Anthracite coal picked from the dump of a cupola will not burn alone in a stove or core oven furnace, and it is very doubtful if it produces any heat when burned with other coal in a cupola.

Lead is too heavy and penetrating when in a fluid state to be retained in a cupola after it has melted. The ladle should be warmed and the tap-hole left open when melting this metal in a cupola.

The best lining material for a cupola in which tin-plate scrap is melted is a native mica soap-stone.

The sparks that fly from a stream of hard iron at the tap-hole and spout are the oxide of iron. They are short-lived and burn the flesh or clothing very little.

The sparks from a wet tap-hole or spout are molten iron, and burn wherever they strike.

We have probably chipped out, daubed up and melted iron in a greater number of cupolas and in more different styles of cupola than any melter in the United States, and in heats that require from two or three hours to melt, and we have found that 8 pounds of iron to 1 pound of best coke; 7 pounds of iron to 1 pound of best anthracite coal; 6 pounds of iron to 1 pound of hard wood charcoal; 4 pounds of iron to 1 pound of gas-house coke, is very good melting. We have done better than this in test heats, but do not consider it practicable to melt iron for general foundry work with less fuel than stated above.

The best practical results for melting for general foundry work are obtained from $6\frac{1}{2}$ to 7 pounds of iron to 1 pound of coke; 5 to 6 pounds of iron to 1 pound of hard coal; 4 to 5 pounds of iron to 1 pound of hard wood charcoal; 3 lbs. of iron to 1 pound of gas-house coke.

A less per cent of fuel is required in long heats than in short ones, for, as a rule, three to one is charged on the bed and ten to one on the charges, and the greater the number of charges melted, the less the per cent. of fuel consumed.

Ten pounds of iron to one of coke are melted at the Homestead Steel Works, in cupolas that are kept in blast night and day for six days.

Less fuel is generally required to melt iron in the foundry office than is required to melt it in a cupola.

Use a light blast when melting with charcoal or gas-house coke.

If you go into the foundry when the heat is being melted and find the tap-hole almost closed, the spout all bunged up and the melter picking at the spout with a tap-bar and running a rod into the tap-hole a yard or so in his efforts to get the iron out, and remark to him: "You are having some trouble with your cupola to-day," he will say: "Yes, we have some very bad coke to-day, sir; that last car is poor truck;" or, "We are melting some dirty pig or scrap to-day, sir." He never thinks: "We have a very poor melter to-day, sir."

At the first meeting of the American Association of Foundrymen, held in Philadelphia, May 12, 13, 14, 1896, one of the delegates was Mr. C. A. Treat, a good-sized practical foundryman weighing over 300 pounds, and representing the C. A. Treat Mfg. Co., Hannibal, Mo. After the meeting had effected a permanent organization, transacted all its business and was about to adjourn, Mr. Treat arose, and in his quiet way remarked: "Gentlemen: Since we have formed an organization of foundrymen for our mutual benefit, don't you think it would be a good idea for foundrymen to stop lying to each other?" The burst of laughter that followed this remark was loud and long. It would be a great relief to many foundrymen if some foundrymen would take the hint and stop lying about the large amount of iron melted with a small amount of fuel, fast melting, etc.

A few years ago, a foundryman who was about to publish a work on foundry practice, being desirous to obtain some reliable data on cupola practice, had several hundred blanks printed and sent to foundrymen in different parts of the country, with the request that they fill in the amount of fuel placed in the bed and charges, the amount of iron placed on bed and charges, diameter of cupola, height of tuyeres, etc. He was surprised at the reports received in reply. Many of them showed that the men who filled in the blanks either knew nothing at all about a cupola, or, knowing the report was to be published, were desirous of making an excellent showing of cupola work in their foundries, and in many of the reports the cupola was filled with stock in such a way that not a pound of iron could have been melted in a cupola charged as indicated in the formula. In some cases, the amount of fuel placed in the bed was not sufficient to fill to the tuyeres a cupola of the diameter given; in others, the fuel placed in the charges was not sufficient to cover the iron and separate the charges; and it was only after pointing out these mistakes and returning the reports for correction, in some cases two or three times, that they were put in any kind of shape for publication.

Some fifteen years ago, when we took a more active part in melting than at the present time, and occasionally published an account of heats melted, we were repeatedly criticised in print by some would-be melters, who were melting anywhere from ten to twenty to one, for using too large a quantity of fuel, and sometimes were invited to come to their foundries and get a few points on melting before publishing another work on the subject. We have never learned of any of our critics on the fuel question becoming prominent in foundry matters or rich in the foundry business, and presume they have all saved their employers such a large amount of fuel in melting that they have been placed upon the retired list with half pay.

The heats published at that time were the best that could be melted in the cupolas described, and the amount of fuel consumed was generally about seven to one with hard coal and eight to one with best Connellsville coke. The foundrymen who at the present time melt heats of the same size in cupolas of the same diameter, with a less per cent. of fuel, are like angels' visits, few and far between.

CHAPTER XXIII.

CHEMISTRY OF FOUNDRY IRONS.

WHEN introducing our compound flux and making tests with it in foundries in 1876, we found several lots of iron at a number of stove foundries in Albany, N. Y., made by the Crane, Allentown, and Thomas Iron Companies, that ran very hard and uneven in stove plate. By the use of the compound these foundries were enabled to use these irons and produce a good, soft, even plate.

The Crane Iron Co. learning of our success in working their iron, as to which they had received many compliments, sent for us to see if we could suggest a means of improving its quality in the blast furnace. As the compound was not suitable for blast furnace work, we suggested that they employ a chemist to analyze their fuel, ores and iron, and to locate the trouble. This they did, but all of the chemist's attempts to detect and overcome the difficulty at that time proved failures. It was only by the old process of leaving certain ores out of the mixture that the objectionable characteristics of the iron were located and an iron of the desired quality produced.

This we believe was the first attempt to make chemistry available in blast furnace practice in the production of foundry iron, although chemistry had for a number of years previous to this time been employed in the production of steel. The Crane Iron Company did not however entirely abandon the use of the laboratory they had fitted up, but continued, from time to time, to employ a chemist. We believe they were the first company to make a success of the utilization of chemistry in the production of foundry iron, of which iron they have ever since made a specialty. Their furnaces supply one of the best

brands of iron used by founders in the eastern part of the United States.

Since the success of the Crane Iron Co. other furnace-men have been guided by chemical principles until the practice has become almost universal, and at the present time all of the standard brands are sold by their analyses, a statement of which is furnished with each carload of iron, and in many localities it is only when foundry irons are very scarce and in great demand that they can be sold without such analysis. These analyses when accurate are of great value to the founder who has learned how to utilize them in the mixing of various irons, in order to produce one having the qualities demanded in his castings. But to the founder who has not acquired this art these analyses are of little value. They are, however, of value to the furnace-man, as they frequently enable him to convince the founder that his iron is all right although it may not produce a desired quality of iron in castings, and the founder must look to other irons which he uses for the cause of his trouble. The defence of the quality of an iron by analysis in this way and placing the responsibility for bad results on other irons, has forced many furnace-men to employ chemists and furnish analyses to prove that their irons were up to standard and to keep them upon the market as foundry irons. The time is, it is believed, not far distant when founders engaged in the production of certain lines of castings will be forced to defend the quality of the irons in their casting in the same manner.

FOUNDRY CHEMISTRY.

There does not appear to be any record of the time at which chemists were first employed in foundries in this country or of what success they met with, but it was probably about the year 1876; for that was the time at which the eminent foundry chemist, Mr. Alexander E. Outerbridge, Jr., took up the work. He may, however, not have been the first to engage in this line of chemistry and make a success of it in certain kinds of castings. He no doubt was the first to make a success of the

chemistry of foundry irons in all its details and applications, which means far more than the mere making of analyses.

As Mr. Outerbridge has been in close touch with the work for many years and is no doubt more familiar with its history than any other man, we have called upon him for a sketch of the history of foundry chemistry, and he has furnished the following short, though comprehensive, history :

CHEMISTRY IN THE FOUNDRY.

BY A. E. OUTERBRIDGE.

A chemist in a foundry was formerly regarded as a freak, and he was thought to be as much out of his proper sphere as the proverbial "bull in a china shop." That day has now gone by, and the substitution of scientific system for empirical methods in progressive foundries has gradually grown from very small beginnings until now it has achieved a recognized position of some practical importance.

The earliest attempts to introduce chemical science into daily practice in foundries appears to have been due to car-wheel makers, and the reasons therefor are not difficult to discover. In the manufacture of chilled cast-iron car wheels the pig-iron used must possess peculiar properties which are somewhat antagonistic, viz. : Softness with dark open grey fracture combined with high chilling quality. These properties are not essential for ordinary grey iron castings.

In the early days of the manufacture of car wheels cold blast charcoal iron was readily obtainable, and it happened that this iron possessed these requisite qualities, so that the car-wheel maker found little difficulty in obtaining suitable metal for his purposes. Indeed, the birth of this important American industry is largely due to this fortuitous circumstance. In course of time, however, conditions changed ; charcoal became comparatively scarce and dear, warm blast was substituted for cold blast, anthracite fuel crowded out charcoal, and it, in turn, was crowded out by coke. The product of the warm blast charcoal furnaces, the hot blast anthracite stacks, and the still hotter

blast coke furnaces, is very different from the product of cold blast charcoal furnaces, and car-wheel makers found it more and more difficult to secure metal having the requisite properties, ready made, as it were; they were, therefore, compelled to investigate the causes of these differences with the hope of finding a way out of their troubles.

About the year 1878 Dr. Dudley, the chemist of the Pennsylvania Railroad, took up the subject and made a number of analyses of the pig iron used in the car-wheel foundry of the railroad company at Altoona, as well as of the car wheels made therefrom. At that time the car wheels were cast at Altoona from a mixture of anthracite and charcoal irons together with steel scrap, the latter imparting the necessary chilling properties. Prior to this, however, other car-wheel makers had instituted similar investigations with the view of ascertaining the reason why some brands of pig-iron were exceedingly sensitive to chill and others not only insensitive, but capable of destroying the chilling property of any car-wheel mixture. These prior tentative attempts were not productive of much practical value.

At that time, and for years subsequently thereto, the grading of pig iron for foundry purposes was dependent entirely upon fracture, and although as long ago as 1882 the prediction was made that "the time is coming when pig-iron will be sold on its chemical analysis, instead of on the crude methods of grading at present in vogue" no attention was paid to this printed statement.

The prediction has been, in a measure, fulfilled, for a number of progressive foundries are now using chemical analysis as the guide in purchasing pig-iron and in using it for all castings, and the advantage as well as the economy of this procedure is no longer a subject of debate, but, though there is a legitimate field of usefulness for chemistry in the foundry, it must be cultivated by a practical founder in order to yield valuable crops.

Erroneous theories and absurd statements have been ad-

vanced by writers on the subject, who are neither chemists nor metallurgists, but notwithstanding this, progress has been made in the founders' art, so that in spite of the greater strides made in the sister art of casting steel, the day of cast-iron has not gone by.

A. E. O.

Although chemists had been employed at blast furnaces producing foundry irons, and at foundries manufacturing certain lines of castings as early as 1876, it was not until 1885 that foundry chemistry began to attract general attention, and it was about this time iron first began to be sold by analysis to any extent. About 1890 the various foundrymen's associations took up the consideration of the matter and endeavored to advance it by endorsing and advocating it; and as Mr. Outerbridge states, erroneous theories and absurd statements were written by men unfamiliar with the work. Some of these erroneous theories were taken up by practical founders as the correct ones, and their advocacy by these men has greatly retarded the advancement of foundry chemistry.

INVESTIGATION OF FOUNDRY IRON.

In order to ascertain what real benefit was being derived in foundries from chemistry, we made a practical investigation of the matter in 1899, and as a result of this investigation wrote the following article which appeared in the *Iron Trade Review*, January 18, 1900:

The Chemist and the Foundry.

I have read with a great deal of interest the many valuable papers on chemistry and foundry practice, published in *The Iron Trade Review* in the past few years. I have also visited many foundries and learned the opinions of many practical foundrymen on the application of chemistry in general foundry practice. While all are willing to adopt anything that will give greater certainty in the production of good castings, many are skeptical of the results that may be obtained from mixing iron by chemical analysis, this being the branch of foundry

practice for which chemistry has been most strongly advocated and to which it has been most applied. This sentiment I have found to be due largely to the experience of foundrymen who, having employed chemists and made a complete failure of mixing iron by analysis, have been compelled to go back to the old method of mixing by fracture and practical experience, or go out of business. Quite a number of firms have become so infatuated with chemical analysis that they have failed in business through the heavy losses entailed by mixing iron in this way. Among them was one of the oldest and largest car-wheel works in the country. The firm mixed its iron by the analysis of its chemists for a number of years. I was informed by their foundry superintendent that they frequently broke up an entire cast of 300 wheels, after they were taken out of the annealing pits, for the reason that the mixture of iron did not give the required strength and chill. These losses, together with many wheels condemned after they had been put in use, compelled the firm to go into the hands of a receiver, and after reorganization the same practice placed them in a receiver's hands the second time, and finally out of business.

The failure of the application of chemistry to foundry practice in cases investigated does not appear to have been due to chemistry, but to the chemists, who in many cases have shown themselves wholly incompetent to do the work required of them. At one large radiator works visited, a complete laboratory had been fitted out at great expense, and a chemist employed, who, when a determination was wanted at once, would say: "the sky is too blue to-day," or, "the clouds are too low," "the atmosphere is too clear," or "too heavy," etc.; and the laboratory was abandoned as a failure. At another large foundry where failure was reported, the chemist was found to have made accurate determinations by submitting samples to other chemists. But after repeated failures to obtain desired results from his determinations it was found that he could not add up a column of ten figures correctly, and could not figure out the results of his determinations, and apply them to various irons to be used in a mixture for a heat.

In other cases where failures were reported, the chemists made the excuse that the sample was dirty, was too fine or too coarse, was not taken from the right part of the pig, the pig was not a fair sample of the iron, etc. To overcome these excuses for failure, pigs have been carefully selected, planed and polished, to remove sand and dirt, and samples taken from different parts of the pig, with no better results in the mixture, this experience being followed by the excuse that the reagent was not good, the apparatus was not of the latest improved pattern, etc. In fact, the foundry chemist in many cases, appears to have taken the place of the old professional melter, who enveloped the management of the cupola in mystery, seldom melted a good heat, and for the many very bad ones melted, always had an excuse which his employer was bound to accept, for the cupola was a mysterious foundry apparatus which no one but the old melter knew anything about.

These excuse-making melters were so accurately described in my work, "The Founding of Metals," published 1877, that they have almost ceased to exist, and foundrymen are not likely to replace them by excuse-making chemists. If the chemist is ever to gain a foothold in the foundry, he will have to do it by the results of his determinations, and not by making excuses for his failures.

A man to be a foundry chemist must be a thoroughly up-to-date chemist, capable of making in the shortest possible time an accurate analysis of all the materials employed in founding, such as metals, coke, coal, fluxes, fire-brick, clay, sand facing, etc. After making an analysis of these various substances and determining their component elements, he must be able to state positively if the material is suitable for the purpose for which it is to be employed in the art of founding. For example: After making a determination, of the carbon, silicon, sulphur, phosphorus, magnesia, etc., in irons submitted for analysis, he must be able to state if any one of the irons when remelted will possess all of the characteristics of an iron best suited for the work to be cast. If not, will a mixture of

one or more of the irons produce an iron of the requisite quality, and what per cent. of each should be employed in the mixture? Does a coal or coke submitted contain the requisite number of heat-producing units to do fast and economical melting? Does it contain elements detrimental to iron in sufficient quantities to affect unfavorably the quality of iron melted with it? Can such deterioration be overcome by changes in the mixture of iron if other fuel is not obtainable? Has a fire-brick the necessary refractory properties to make a good cupola lining for the grade of fuel, flux and iron melted, or would another quality of brick last twice as long under the same conditions? Is a given clay suitable for cupola daubing, ladle lining, loam cores, etc.? Has a sand the requisite properties of a good molding sand? Will it give a smooth surface in light work, or withstand the action of a large body of molten iron in heavy work? Will a facing wash before the molten iron, become damp so rapidly that it can not be slicked or the pattern returned, produce a smooth casting, harden the iron, etc.? Is the limestone or other material suitable for a cupola flux, will it keep the cupola working open and free throughout a heat, clean and improve the quality of iron, protect the cupola lining, or cause it to burn out more rapidly?

All these points—and many more—must be determined by the foundryman before he can produce first-class castings. At the present time they are determined by what is known to the practical foundryman as experimental or trial foundry practice, and to those unfamiliar with the details of foundry work, as the “rule of thumb” foundry practice.

If the material used in forming a mold does not produce a perfect casting or the iron used does not possess the required degree of hardness, softness or strength, the casting is condemned and broken up, and the cost of determining the suitability of foundry material is represented by the cost of these condemned castings, and the cost of the condemned material, which may remain on hand for years or be thrown in the dump. The loss on such material is no small matter in many cases; as

we have frequently seen tons of condemned iron lie in the foundry yard for years, barrels of blacking stand around until the barrels fell to pieces and the blacking was thrown into the dump, and piles of molding sand and clay reach the same destination after repeated failures to use them successfully.

If the chemist can determine the suitability of these various materials for the purpose for which they are to be employed in founding, at a less cost and with more certainty than by the present method, then the foundryman wants the chemist. If he cannot, the foundryman has no use for him.

To do this, the chemist must have some practical knowledge of the art of founding to enable him to apply the knowledge he has obtained by his analysis, and produce in casting the results indicated by his determination, and to overcome the prejudice or ignorance of the foundry foreman, melter and molders. For instance, a melter from ignorance or habit may not make up his cupola in the best shape for melting. He may charge the fuel by counting the shovels, weigh the iron by counting the pigs and shovels of scrap, place too much or too little fuel in the bed and charges, melt iron too high or too low in the cupola and with uneven temperature. From prejudice against the chemist, he may not weigh the iron accurately or use the proper per cent. of different grades in the mixtures; mix the iron in charging unevenly, etc. Pig and scrap, when not properly charged, and the cupola tapped close, will give all pig in one ladle and all scrap in another. High silicon and low silicon irons, hard and soft irons may be drawn in the same way. Iron melted too high in the cupola is hardened, and iron melted fast and slow, hot and dull, in the same heat, is not of the same degree of hardness, softness or strength throughout the heat.

It will thus be seen that a chemist who has no practical knowledge of the management of the cupola, is entirely at the mercy of a poor or prejudiced melter, and can never be certain of the results of a mixture made according to his determination. To overcome this difficulty and make himself master of

the situation, the chemist must be a thorough practical melter, capable of chipping out and daubing up a cupola in the best possible shape for melting, and make up the cupola for a heat. He should know the exact amount of fuel required for the bed and each charge, and the exact amount of iron to be melted on the bed and each charge of fuel; when the bed is properly burned for charging; the mixing of irons in charges to produce an even mixture when melted; and to melt an equal amount of iron of an even temperature every minute from the beginning to the end of the heat. It is not necessary that the chemist should do all this work, but he should be able to instruct the melter how to do the work, have full charge of him, and see that the work is correctly done, and the best possible results in melting obtained from the cupola.

He must also be able to defend his iron in the castings, for there is no mechanic on earth that can give more plausible excuses for bad workmanship than the poor molder. When a casting is condemned and broken up, the chemist must be able to say from the fracture whether the iron is hard or soft, if hardness in a casting is due to the iron, wet molding sand, hard ramming, finishing the mold with a swab, strong facing, etc. If there is dirt in the casting, was it in the iron and could not be removed, or did it come from a dirty mold, careless skimming, bad pouring, etc.? He must be able to defend all material he has analyzed and recommended for use in the foundry in the same manner.

Where is the foundry chemist to obtain this practical knowledge? There are no colleges that we know of, in which foundry practice is taught, in connection with a course in chemistry. There are no mechanical schools in which chemistry is taught, in connection with a practical foundry course. The chemist, after he has obtained his diploma from a college or other school, may take a course in foundry practice in one of the mechanical schools; but so far as we have been able to learn, this course is not especially adapted to the training of chemists in foundry practice, and the would-be foundry chemist, after

receiving his diploma in chemistry, has been compelled to get his practical knowledge in the foundry at which he is employed.

Where the chemist has been a practical man as well as a chemist, and the foundryman has been a practical foundryman and given the chemist his hearty support, the chemist has been able to gain this practical knowledge and make foundry chemistry a success. But in cases where the chemist was not a practical man or the foundryman did not give him his hearty support, foundry chemistry has been a failure, from lack of proper training of the chemist; and up to the present time foundrymen have derived more benefit from the blast-furnace chemist than from the foundry chemist. This should not be the case, and would not be so if schools were established to give the foundry chemist a proper training for the work to be done. It seems to me that the trade or mechanical schools might well take up this branch of instruction and give a practical course in foundry chemistry that will at least give the student some idea of what is required of him, and how to gain this practical knowledge when employed in a foundry.

CONTROVERSY WITH THOS. D. WEST.

This article brought forth a reply from Mr. Thos. D. West, who had adopted one of the absurd theories advanced by writers unfamiliar with the work, and had been advocating the confining of the chemist's duties to the laboratory, and his responsibility to the making of correct analysis, leaving the responsibility of mixing and melting of irons to the founder, foreman or melter. As our investigation had shown this system to have been a failure in all except a very few instances in which the founder was a practical melter, and had worked with the chemist and made his work a partial success, we took the stand that if chemistry was ever to be made of value to the founder, the chemist must be a practical metallurgist, mixer and melter of iron, and responsible for results of his determinations and mixtures made by them at the spout or in the castings.

After numerous articles by Mr. West and myself had been published setting forth our views upon the subject, the editor of the *Iron Trade Review* asked a number of eminent and experienced founders and chemists for their opinions of the controversy and received replies from the following gentlemen, all of whom fully endorsed my view of the matter, and advocated a larger field of usefulness for the chemist than the laboratory, and some of them advocating a still larger field than we had done:

Frank L. Crobaugh, H. M. Goodrich, S. B. Marshall, E. C. Johnson, M. W. Shed, E. C. Wheeler, A. E. Outerbridge, Sr., J. S. Bancroft, R. S. McPherran, B. S. Summers, Chas. Bauer, Dr. W. B. Phillips, C. H. Vannier, Dr. Moldenke, G. C. Davis, Prof. R. H. Richards.

BROUGHT TO THE ATTENTION OF THE FOUNDRYMEN'S ASSOCIATION.

This controversy attracted such widespread attention that we were induced to bring the matter before the Philadelphia and Pittsburg foundrymen's associations, and also before the American Foundrymen's Association, which we did in the following paper, which was read before the association at their annual meeting at Chicago in June, 1900.

The Training of Foundry Chemists.

Permit me to present for your consideration a few thoughts upon foundry chemistry and proper training of foundry chemists. At the present time there is not an institution of learning in this country that gives a practical course in foundry chemistry. While the employment of chemists in foundry practice has been strongly advocated for a number of years by the various foundrymen's associations and leading founders, they have failed to take any steps whatever to provide chemists educated for this work. And at the present time, it is impossible to obtain from the graduating class from any of our colleges and schools a single chemist that is capable of doing anything as a foundry chemist, save making analysis of irons.

Not only are there no schools for the proper training of foundry chemists, but there are practically none for the teaching of foundry practice; while many other industries are taught at boys' mechanical training schools, in which boys are given a technical education in the line of the industry preparatory to learning a trade.

To prepare a student to become a chemist in foundry iron, he should be given a practical course in analysis of coke, coal, iron, and the mixing of irons from analysis that will enable him to produce from his analysis an iron at the cupola spout having any degree of hardness, softness and strength required in the various grades of work to be cast. And he should be given a practical course in cupola management in every detail, from the chipping out of a cupola to dropping of the bottom. To prepare a student for a foundry chemist, as well as an iron chemist, he should be given a practical course in analysis of coal, coke, iron, fire-brick, clay, loams, sands, facing, and all materials employed in foundries. When employed at a foundry, he should be competent not only to manage a cupola and produce irons suitable for the various grades of castings, but he should be competent to determine by analysis whether a sand is a good molding sand or not; if sands are suitable for heavy or light castings; if a facing or blacking will peel the sand from heavy or light work and give a smooth surface. And he should determine by analysis the suitability of all foundry material for the purpose for which it is to be employed in foundries, the suitability of which is now determined by trial of material—and loss in many cases from poor material. With a chemist properly trained in analysis, mixing and melting of irons, foundry irons can no doubt be greatly improved. With a chemist properly trained as a foundry chemist, foundry practice, in my opinion, can be revolutionized and a much higher grade of castings produced at a less cost than at the present time. To educate chemists for this work a thorough, practical course in foundry chemistry should be established as one of the courses of the curricula of all large technical schools. To pre-

pare boys for learning the art of molding and better fit them for foremen and managers of foundries, a course in technical and practical foundry work should be advocated at all the boys' mechanical training schools in this country.

These thoughts are respectfully submitted for your consideration, and should they meet with your approval, I would suggest that the American Foundrymen's Association as a representative body call the attention of the institutions of learning to the demand for practical chemists and founders, and urge them to take the necessary steps to supply the demand.

Under the present system of foundry chemistry as advocated by some of our leading founders and practiced in some foundries, the chemist is only required to make analysis for the founder or foreman from which to make mixtures of iron, and the chemist is only responsible for the accuracy of his determination. That this system does not give satisfactory results is clearly indicated by the small number of foundries employing chemists, and failure to improve the quality of foundry iron under this system. The chemist should not only be given charge of the laboratory, but should be given full charge of the cupola, the mixing and melting of irons, and be held responsible for the quality of iron at the spout. This is the practice in every foundry in which chemistry has been a real success. At one of the largest and best known foundries in this country, at which a chemist has been employed for many years, the chemist has full charge of the laboratory, cupola and iron, and is not only responsible for iron at the spout, but has been under a written guarantee for years to produce iron at the spout having the density, hardness, softness, strength, etc., called for in specifications for government and other engineering work. At this foundry, castings are made in the same heat, weighing from a few ounces to many tons, for all of which a suitable iron must be provided. That a properly educated chemist can produce such irons at the spout has been clearly demonstrated at these works.

Working on the silicon basis system in foundry irons has

enabled the founder to produce castings with a little more certainty as to degree of hardness and softness than by the fracture system. Beyond this it has been of no advantage to the founder, and to the foundry industry it has been a decided disadvantage, and if persisted in, will ruin the industry. This may seem a broad assertion to those who have not investigated the matter, but those who have will, no doubt, fully agree with me. That silicon reduces the strength of cast iron is a well-known fact; and that the greater certainty in the degree of hardness and softness in castings is at the expense of the quality of iron is also a well established fact.

Since the introduction of this system, it has been the aim of almost every furnaceman making foundry iron to increase the per cent. of silicon in his iron. And silicon has been increased to so great an extent that the quality of foundry iron has been greatly reduced; and the practical founder is no longer working for high silicon irons, but for an iron low in silicon or free from it, that his casting may have strength and other desirable properties that are destroyed by silicon in cast iron.

What the founder wants, to hold his own against steel, is a foundry iron having all the characteristics of the hot and cold blast charcoal foundry irons of forty years ago. That such an iron cannot be produced by the silicon basis system is a well-known fact to every practical iron chemist, and the sooner it is discarded and the true basis for the manufacture and mixing of foundry irons sought for, the better it will be for the foundry industry. Many lines of castings amounting to thousands of tons yearly, have been lost to steel. Many more will be lost if something is not done to improve the quality of foundry irons.

It is high time, gentlemen, that you rouse from your slumbers and gird on your armor in defense of your industry. If you do not, your foundry plants will be left to rot as have the rolling-mill plants of this country; for this is the age of steel, and only by an improvement of foundry iron can the founder hold his own against it!

Each of these associations appointed committees to consider the matter, and at their next meeting the committee appointed by the Pittsburg Association made the following report:

TECHNICAL TRAINING FOR FOUNDRY MANAGERS.

At the business session preceding the reading of the papers the committee appointed at the previous meeting, consisting of Wm. Yagle, T. D. West, S. M. Rodgers and the chairman, Dr. Moldenke, presented resolutions in accordance with the request made at that meeting, upon the suggestions embodied in Dr. Kirk's letter. Chief among these was that the study of foundry practice be introduced as one of the courses of the curricula of the larger technical schools. The report, which was adopted, was as follows:

"We, the committee appointed by the Pittsburg Foundrymen's Association to consider the several suggestions contained in Dr. Kirk's letter to this association, report the following:

"*Resolved*, 1. That the foundry industry has arrived at a point where there is a demand for managers properly trained in the principles of scientific and commercial founding.

"2. That a representative body, such as the American Foundrymen's Association, be requested to draw the attention of the institutions of learning in this country to this fact, and urge them to take the necessary steps to supply the demand.

"3. That the Pittsburg Foundrymen's Association authorize the appointment of a committee of five, acting in conjunction with committees that may be appointed by other foundrymen's associations, to memorialize the American Foundrymen's Association in accordance with the above resolutions."

On the new committee the chair reappointed the three members of the former committee, adding Secretary Zimmers, and in accordance with the request of the former committee, Dr. Moldenke will act as chairman, thus making the fifth member.

This committee has been kept in existence ever since, and

has done excellent work in the establishment of schools. The committee appointed by the Philadelphia association have never been heard from, and were probably drowned in the Delaware or Schuylkill.

The American Association appointed a committee to work in conjunction with that of the Pittsburg Association, and these two committees have succeeded in calling the attention of the faculties of a number of technical schools to this field of education and to have a course on foundry chemistry and practice included in their curricula and also in having a number of new schools opened for this work. Probably the courses established in some of these schools are not fully up to the requirements of the founder, but they will no doubt be improved as the requirements of the founder become more fully understood, and in time practical and scientific founders will in all probability be turned out from them.

CHEMISTS FOR PRESENT NEEDS.

From the schools that have already been opened for foundry training, and others that no doubt will be opened—for these committees have not finished nor given up their work—practical founders and chemists will no doubt be obtained, but some years must elapse before these men will be available for foundry work, and the question arises, where are the foundries to obtain practical chemists for present needs? There are two means of supplying them more rapidly than the schools can do, viz., by taking young men who have graduated in chemistry into the foundry and teaching them foundry practice in connection with chemistry, or taking young men who have served their apprenticeship as molders and teaching them foundry chemistry. By either of these means the founder may obtain a practical and more experienced chemist in a short time than can be hoped for from schools for some years to come. It has been the practice at steel plants for many years to educate their own chemists in this way, or by permitting their chemist to take a number of laboratory students to whom

the firm pays a small salary after they become competent assistants, and the chemist receives a tuition fee from the student for instructions.

These are the only means that have been provided for the training of practical steel chemists, and that they have been a success is proven by the rapid and successful growth of this industry, which depends upon chemistry for its existence, and has almost driven wrought-iron from the market and greatly reduced the demand for iron castings. By the establishment of schools for the scientific training of founders in chemistry and all the details of foundry practice, it is hoped to place this industry upon a more scientific basis, retrieve its loss and restore to cast-iron its former prestige.

But let us have a little advancement while we are waiting for the schools to do their work.

GRADING AND MIXING IRON BY ANALYSIS.

The grading of foundry iron by analysis at blast furnaces has to a large extent taken the place of grading by fracture, and present indications are that it is only a question of time when analysis will entirely replace fracture grading, for this method of grading has proven more satisfactory alike to the furnaceman and founder in many cases, when accurately and fully understood by the founder. The analyses furnished with each car-load or lot of iron show the per cent. of various metalloids it contains that exert an important influence on the characteristics of the iron when melted and cast. By learning the per cent. of various metalloids in iron best suited for work to be cast, the founder is able to produce castings with a greater degree of certainty as to quality of iron than by fracture grading.

The selection or mixing of iron by analysis for castings at the present time is largely upon the silicon basis, that is, this metalloid is considered the most important one in determining the characteristics of an iron, although other metalloids, such as sulphur and phosphorus, are taken into consideration. The

per cent. of silicon the iron contains is supposed to indicate the per cent. of free and combined carbon and degree of hardness, softness, strength, chilling and annealing properties the iron may possess when cast in various sized castings.

Before purchasing an iron the founder determines by analysis of castings having the desired quality of iron, the per cent. of silicon they contain, and then selects or orders a pig having this per cent. of silicon, or one having a greater per cent., that it may be melted with old and remelt scrap and possess the per cent. desired in the castings when cast. Founders and furnacemen have learned the per cent. of silicon most suitable for various castings to vary from $\frac{1}{4}$ to 3 per cent., and the founder has only to make known the per cent. of silicon desired or class of castings and per cent. of scrap to be melted, to obtain pig from which castings may be produced with a greater degree of certainty than by fracture grading.

This kind of foundry chemistry appears to answer very well for certain lines of castings and for small foundries that can not afford to employ a chemist. But it can not be called chemistry of foundry iron, for it is only rudimentary chemistry, in which all the finer points are lost or overlooked, and no large foundry, such as those making large, heavy castings under specifications requiring iron having a specified density, transverse strength, tensile strength, etc., would think of depending upon this kind of chemistry in selecting iron for such castings. In selecting iron for such castings, one of which may be worth a thousand dollars or more, all the metalloids and their effect upon the iron are taken into consideration, and also effect of impurities in fuel upon the iron in melting, and an iron produced at the spout having with a certainty all the characteristics required in specifications. This can only be done by an experienced chemist, and grade analysis is of but little value.

In mixing iron by grade analysis, the only rule or guide understood and practiced by a majority of founders is the known per cent. of silicon the casting should contain, and the founder endeavors to obtain this amount in his castings. This

he may readily do if his iron is properly melted. Castings are heavy, remelt light, and pig alone is used by purchasing pig having the required amount of silicon. But these conditions are seldom found in a foundry, for in all foundries it is necessary to make a mixture to work up remelt scrap, if nothing else. In others, it is necessary to melt old scrap received from customers in part pay for new work, and in others scrap and a number of brands of pig are purchased to obtain a cheap mixture, so that in practically all cases mixtures are made, and in many cases desired resultant mixtures are as difficult to obtain as by fracture grading. This is more especially the case when old scrap or a number of brands of pig are used. The remedy commonly applied in such cases is a pig high in silicon, but this does not always overcome the difficulty, and the founder is compelled to change his mixture and perhaps leave a pile of iron in the yard for months, just the same as when mixing by fracture. This difficulty may be overcome by the founder to some extent by a close study of analysis in mixtures, but few of them have the time or inclination to go so deep into the science, and at the present time it is only the easy problems in mixing by analysis that are being solved by the founder.

CHEMISTRY AND CUPOLA PRACTICE.

That practical chemistry is of value to the founder has been fully demonstrated in many foundries, and that the value of chemistry to the founder may be destroyed by bad cupola practice has also been fully shown. Scarcely a week goes by that we do not learn of trouble with iron due entirely to bad melting. Only last week I was called upon to visit a foundry that had been in operation for 19 years to see what was wrong with their cupola, from which they could not obtain hot iron.

Upon investigation, I found that the iron was not only not sufficiently hot to run light work, but was dirty in heavy castings with shrink-holes in hubs or other heavy parts of castings. These shrink-holes and dirt entirely disappeared when the iron

was properly melted; which showed they were not due to the quality of iron, but to the way in which it was melted.

Of what value would chemistry have been in this case? Of none at all, for the elements or metalloids that caused these shrink-holes were not in the iron before it was melted nor when it was properly melted, and the cause of them could not, therefore, be determined by chemistry in time to prevent them occurring in the casting, and if determined after the casting was made and a change made in mixture to prevent their re-occurrence, they might again be caused by another form of bad melting. In this way a practical melter can destroy the results of any chemist's work almost every heat, and a poor melter may destroy them without knowing he is doing so.

The only way the chemist can expect to overcome this difficulty and be certain of results is to become a practical melter. This he may readily do from a little practical instruction after learning the theory of melting in a cupola.

To be a practical melter it is not necessary that a man should be a pattern maker, green or dry sand molder, core maker, expert on molding sand, facings, etc., or that he should know all about calorimeters, pyrometers, degrees of heat in a cupola, temperature at which iron should be melted, poured, etc., etc.

Scarcely one practical melter in a hundred knows anything about these things more than he may observe by daily contact with them in the foundry. As for degrees of heat, no instrument has yet been designed that correctly or approximately indicates degrees of heat in a cupola or blast furnace. The pyrometers used by blast furnacemen are only for indicating temperature of blast, and it is doubtful if any other temperature can ever be obtained, for the peculiar construction and working of cupolas and furnaces preclude the possibility of applying any temperature instrument to them at the melting zone.

The melting of iron in a cupola, while by no means a trifling matter as some founders profess to believe, is an art that may be readily learned when the theory of melting is once fully

understood. This theory is based upon the space occupied by fuel and iron in a cupola, and not upon the heat producing units of fuel consumed in melting as is only too often the case.

When a few small shovels of fuel are consumed in a heating stove only a limited amount of heat is produced, and it is only when the stove is filled with fuel that its full heating capacity is realized. For the greater the amount of fuel consumed the greater the heat produced.

But this is not the case in a cupola, and we get no higher degree of heat by filling the cupola to the charging door with fuel than we do by filling it to only 15 to 20 inches above the tuyeres. Not a pound of iron can be melted on fuel at the charging door, or at any point within many feet of it in a cupola of a proper height, no matter how great the amount of fuel consumed. This we have proven by fastening bars of iron in the lining, from the bottom to the charging door, so they could not settle with the fuel as this burned away, and filling the cupola with fuel to the door, before putting on the blast for melting, and burning up all the fuel with a blast sufficient to melt iron before dropping the bottom. In these experiments it was clearly proven that iron can only be melted within a limited space in a cupola which is designated the melting zone, and therefore a cupola is a space furnace.

The space or zone in which iron may be melted is from 10 to 14 inches in depth, and it cannot be melted at all above or below this zone, and the space in which it may be melted properly is from 6 to 8 inches. The point at which this zone is located in a cupola varies with the kind of fuel used and volume of blast.

With coal it is 6 to 14 inches above top of tuyeres, and with coke 12 to 20 inches, and may be raised a few inches by a large volume of blast and lowered a few by a small volume. But 14 inches with coal and 20 with coke will generally be found to be about a proper height for a bed, which represents the top of melting zone.

The top of bed is lowered from 6 to 8 inches in melting iron

placed upon it, and only the weight of iron that can be melted by lowering the top of bed to this extent should be placed upon it. The next charge of fuel should only be sufficient to replenish the bed and raise the top of it to its original height when melting began.

The iron placed upon this fuel should only be the amount that can be melted in consuming it, and each charge of fuel and iron should be of such proportions that when the charge of iron is melted, the charge of fuel will only be sufficient to raise the top of bed to the same height it was when melting began.

When a bed is of a proper height to begin with, and this rule of charging is closely followed and the cupola slagged, melting may be continued as long as lining lasts, and hot iron of an even temperature produced throughout the heat.

But when a bed is not of a proper height, or the charges of fuel and iron are not of correct proportions, even a small heat cannot be melted without change in temperature of iron, which may be sufficient to necessitate dropping the bottom.

The most important point in melting is to have a bed of proper height to begin with, for if we do not have this there can be no accurate system of charging. The construction of cupolas and volume of blast supplied to them vary to so great an extent that no exact measurement can be given for a bed that will hold good in all cupolas, but 12 inches with coal and 20 with coke above top of tuyeres will generally be found to be about the correct measurement for a single-tuyere cupola. For double-tuyere cupolas the second row of which, as now constructed, are of such a variety of areas that not even an approximate measurement for bed can be given that will hold good in all cupolas.

In determining the height of a bed I have found it a good plan to begin with a presumably high bed and 3 pounds of iron on bed to 1 pound of fuel and 10 pounds of iron to 1 of fuel in charges, and to gradually reduce the bed each heat until a hot even iron is obtained throughout the heat.

The one point to guard against in melting is too much fuel in the cupola; for as dull iron may be made with too great an amount of fuel as with too little, and this is more often the cause of dull iron than too little fuel.

Melters, when iron comes dull, are apt to remember that cold day last winter when they filled up the stove to make a warm room, and to apply the same remedy to the cupola when iron comes dull, and as a result 90 per cent. of melters place too large an amount of fuel in their cupola to do fast melting or make hot fluid iron.

DUTIES OF A FOUNDRY CHEMIST.

In our investigation of practical foundry chemistry, we endeavored to ascertain what the duties of a chemist were, and found that in many foundries in which chemists had been recently employed their duties had not been fully defined, and that they varied to a considerable extent with the class of castings produced in others.

At one large engineering works, in which a chemist had been employed for many years, we found his duties to be about as follows: He had full charge of cupolas and melting and was required to reduce cost of melting to a minimum, to determine the best material for lining, daubing, etc., to analyze all fuel and see that none but that giving best results in melting was purchased and used, and to see that iron was properly and economically melted.

He was required to analyze all irons melted and to make mixtures that would produce at the spout an iron of any desired quality and to familiarize himself with analysis of all the various irons in the market and price of same.

When specifications were received for castings, he was required to state definitely whether or not he could produce an iron having the characteristics called for in specifications, if so the amount of various brands of iron required and cost of mixture. To make all tests of tensile and transverse strength, deflection, etc., required, and to see that iron was at all times fully up

to requirements of the foundry, and in case of special castings, to produce an iron called for in specifications, meet and overcome all trickery and ignorance of civil engineers in testing and construction of castings. He is required to give in advance shrinkage of various mixtures for the construction of patterns, and to state from outlines on blue print if castings can be made from the required mixture without undue strain, hardness or softness in any part of it.

In addition to his responsibility for quality of iron, he is required to see that facing, blacking sand, and all foundry supplies are fully up to the requirements of the foundry, that castings may not be lost from bad material.

This may seem an elaborate amount of work to the young chemist, but it represents only about one-tenth of what the practical founder has been accustomed to do for years, and the chemist is given only this small part of the work that he may be able to look after its details more closely than the busy founder, and obtain better results, and he will not find it an excessive amount of work when he has once familiarized himself with its details.

In large engineering works and foundries the work is divided into departments with a head for each department, and the above outline of work comprises the work of the head of this department, whether he is a chemist or not. But when a competent chemist can be obtained it is entrusted to him.

It should be the aim of every foundry chemist to aspire to this position.

INDICATIONS OF FRACTURE IN FOUNDRY IRON.

How the Chemist can Utilize This Knowledge, which is Necessary to His Success.

The indication of fracture in foundry irons has always played an important part in foundry practice, and must continue to do so even when the mixing and melting of iron is entrusted to a chemist; for there are many things indicated by the appearance of the fresh fracture that are not indicated by anal-

ysis, and are beyond the reach of chemistry, and a few points on fracture indications will no doubt be of interest to the student of foundry chemistry. Without a practical knowledge of fracture indications, a chemist can never become a practical chemist of foundry irons. And, with such a knowledge, his laboratory work may be greatly reduced.

Without a knowledge of fracture indications in the pig, a chemist would be unable to determine whether the iron placed upon the scaffold for melting was the grade of iron analyzed or not; and if placed in charge of a cupola might melt an entirely different grade of iron without knowing it. A white or mottled iron might be palmed off on him as a soft iron by cupola men ignorant of the indications of fracture, or by men having a prejudice against a foundry chemist; a hard iron may be mixed with soft iron by accident, and resultant mixtures indicated by analysis entirely changed at the cupola spout.

To avoid such chances of bad results, the chemist, when making determinations, should not only have borings from various parts of the pig, but he should also have a sample of the pig, at the point from which they were taken, and make a study of the fresh fracture in connection with his analysis. Such a study should be made with the naked eye and also under a glass, and all the peculiarities imparted to iron by the various metalloids should be ferreted out and fully understood, so that the chemist may be able to pick out by fracture, in the yard or upon the scaffold, any grade of iron he has analyzed.

The fracture of a freshly-broken pig indicates to the fracture expert the characteristics of an iron almost as accurately as does an analysis. The chemist, by a study of fracture in connection with analysis, should become more accurate in fracture indications than the expert who is not a chemist, and he should be able to say from the fracture about the per cent. of combined carbon, graphite, silicon, sulphur, phosphorus, etc., an iron contains, and indicate whether it will run hard, soft, strong, weak, open, dense, etc., when melted and cast.

In making such a study, analysis should be made from near

the sow end, tail end and centre of the pig, and a system of averages established both of fracture and analysis. By such a system the average per cent. of the various metalloids contained in an iron may be determined by one analysis from near the centre of the pig, and the number of determinations and amount of laboratory work reduced to a minimum; and more time given to the chemist to look after the cupola and the mixing and melting of iron.

In cast-iron, the characteristics of the iron are indicated by the size, shape and color of the crystals, and are more plainly seen in the fresh fracture than in an old fracture, the color of which has been changed to a greater or less extent, by action of the atmosphere upon the iron.

A very hard iron in the pig has a very small whitish crystal, which gives to the fresh fracture a whitish appearance, and designates it a white iron. This iron runs very hard in light as well as heavy work. In a mottled iron we find a larger crystal of a bluish cast, with white thread-like streaks winding around among the crystals, which designates it a mottled iron. This iron generally runs strong and close in heavy work, but very hard in light work.

A number two iron has a small crystal similar to that of a mottled iron, but without the thread-like streaks within the crystals. This iron runs soft and very close in heavy work, gives a fine finished surface in planed, turned or bored work, but generally runs hard in light castings.

The fracture in number one iron presents a large crystal of a dark bluish cast, and generally runs soft in light or heavy work, but in the latter is very open and porous, and does not give a bright surface when finished; and for finished work has to be mixed with scrap or pig having a smaller crystal.

In silver-grey iron we find a very small crystal similar to that of a white iron, and it is only distinguished from the white iron by the silvery-grey cast from which it receives its name. This iron runs very soft in either light or heavy work, but is so rotten in the pig and when cast that it cannot be used alone for either light or heavy work.

A high silicon iron may have a large or small crystal, but always has a silvery-grey cast of color, and like silver-grey iron, is too rotten to be used alone.

The charcoal irons have a different shaped crystal from the anthracite or coke irons. It is smaller than that of the No. 1 iron, more pointed and sharper to the touch than those of any of the grades of these irons. The sharp-pointed drawn out crystal indicates strength in the iron.

These are the general characteristics of fracture in foundry irons, by which the founder has been guided for many years in selecting iron for the work to be cast or in making mixtures for work, when a suitable iron is not obtainable. The indications of fracture are changed to an almost imperceptible degree by variation in the per cent. of various metalloids contained in the iron, and for this reason the founder is not always successful in making an iron suitable for the work to be cast.

The chemist, by a careful study of fracture in connection with analysis, should be able to overcome this difficulty and indicate from fracture the exact characteristics of an iron in the pig and when cast.

Not only are fracture indications of value to the founder and chemist before iron is melted, but also after it is cast. Without a knowledge of fracture indications the founder would have to file or drill every piece of iron to learn if it was hard or soft, and the chemist, by his science, would have to analyze it. This laborious work may be dispensed with to a large extent by an accurate knowledge of fracture indications, by which the quality of an iron in the casting may be instantly judged from the appearance of iron in the gate or fracture in condemned castings.

In light, thin castings the iron when hard is always white or of a very light color; when soft it presents a small crystal and has a greyish-blue cast. In heavy work it is white or mottled when very hard, and when not so very hard has a very small crystal with a light greyish cast.

When soft it presents a large crystal with a bluish cast

When the crystals are very large, they indicate an open porous iron that does not polish or finish well. An uneven crystalline structure throughout the fracture indicates an uneven or spotted iron with hard spots that are difficult to machine.

In the crystalline structure of castings, the crystals are always larger and the iron more open and porous near the centre of a casting than near the outside, where the iron has been more rapidly cooled.

Light castings are generally harder at some distance from the gate than near it, and the crystals are smaller and lighter in color.

In cracks or breaks from shrinkage and strain, the fracture indicates whether the crack or break occurred when the casting was hot or cold, and also whether the iron was fully set or in a semi-molten state. The fracture of iron broken when hot has not the luster as when broken cold, and is of a dark blue or iron-rust red color, depending upon the degree of heat in the casting at the time of breaking, and manner of cooling after breaking.

The most important evidence of breaking when hot is the lack of luster in the fracture, which may readily be seen by breaking the casting again, and comparing the fresh fracture with the one made when hot.

Iron broken when in a semi-fluid state presents a dull round pointed crystal or no crystalline structure at all, depending upon the condition of the iron when broken. The color varies from a red to a very dark blue. The indications of this fracture are important, as they show if an iron has excessive shrinkage, and parts of the castings, when the iron is in a semi-fluid state, draw away from other parts that are prevented from following by the mold; as frequently occurs in pipe founding, where the body of a pipe cast on end draws away from the bowl as the iron sets, when iron has excessive shrinkage. Were it not for the indications of fracture in such cases, the founder would frequently be unable to determine whether the break was due to excessive shrinkage or careless handling of

the casting when removing it from the mold. It is also of importance in determining if castings are broken in being shaken out too soon after casting, by moulders in a hurry to get through with their day's work and get out of the foundry.

Fracture shows up a dirty iron, and in many cases indicates where the dirt came from; whether due to a dirty mold, careless skimming, bad pouring or improper gating. These and many more important points in foundry practice are indicated by fracture, and they should all be fully understood by the practical founder and chemist who desires to be a master of the foundry business.



INDEX.

- A** BENDROTH BROS. cupola, 58,
59
Jumbo cupola,
349-353
Port Chester, N.
Y., cupola re-
port of, 282,
283
- Adjustable tuyeres, 60, 61
- Anthracite coal as a cupola fuel, 178-
186
introduction of, as cu-
pola fuel, 179
proportion of the charges
of iron to, 97
qualities of, 179
quantity of, in the bed,
93
iron, 209, 210
- Air, amount of, required for the com-
bustion of fuel, 391
chamber, 5, 6, 29-31
air capacity of, 31
connection of gauges with,
387, 388
joints of, 30
location of, 29, 30
material for, 30
chambers, perfect connection of,
380-382
shape of, 31
gauges, 387-389
means of supplying to a cupola,
389
- American Scotch pig, 214
- Analysis, grading and mixing iron
by, 441-443
- Angle iron, arrangement of, 39
- Art in melting, 271-281
- B**ANKING a cupola, 277-279
- Bars for sledging, 109
sizes of, 109
tapping, 109, 110
- Bed, 92-94
and charges, measurement and
weight the best guides for,
196, 197
- Bed, determining the height of a, 446
raising or lowering a, 93, 94
uneven burning of the, 172
weight of fuel required for a, 94
- Belt air chamber, connection of, with
the tuyeres, 382
- Bituminous coal as a cupola fuel,
199-201
- Blakeney cupola, 355-357
tuyere, 50, 51
- Blast, 102, 103
admittance of, to the air (cham-
ber, 31
amount of heated fuel required
for the, 144
and blast pipes, 375-394
arrangement for supplying, to
the cupola, 371
best time for putting on, 104
blowing out of, at the tap hole,
104
furnace, fuel required for, 1
practice, first attempt to
make chemistry available
in, 424
furnaces, 202-204
grading of foundry iron by
analysis at, 441
gates, 385-387
gauges, 387-389
heating the, 366
indication of pressure of, 388
in melting, 389-394
passage of the, 144, 145
pipe, connection of gauges with,
387, 388
joints, 376
pipes, 375-384
and blast, 375-394
arrangement of, 375, 376
best way of connecting, with
tuyeres, 382-384
connections of, with the
cupola, 375, 376
diameter of, 377-379
and area of, 379
direct connection of, with
tuyeres, 380

- Blast pipes, explosions in, 387**
 friction in, 377
 lengths of, 376
 long, 384
 materials for, 376
 table showing the necessary increase in diameter for the different lengths, 378
 underground, 375
 positive and non-positive, relative merits of, 390, 391
 supply of, 12
 taking of the, during a heat, 276, 277
- Blossburg coke, 188**
- Blower and electric motor, 402**
 Buffalo steel pressure, 411-413
 Connersville cycloidal, 396-402
 horizontal cycloidal, 400
 on adjustable bed, and on bed combined with countershaft, 414, 415
 placing a, 384, 385
 near a cupola, 384
 Root's rotary pressure, 403-405
 vertical cycloidal, and engine on same bed-plate, 401, 402
- Blowers, 395-416**
 electric steel pressure, 409-411
 fan, 406-416
 Garden City positive blast, 405, 406
 Green patented positive pressure, 396
 steel pressure, 407, 408
 on adjustable bed with combined upright engines, 408, 409
 Sturtevant, 406-411
 table of speeds and capacities of, as applied to cupolas, 416
 types of, 395
- Bod, definition of, 111**
 for small cupolas, 112
 good, qualities of a, 112
 material, 111, 112
 working of, 113
 placing the, in stopping in, 114
 sticks, 110
 wet, explosion of iron caused by, 296, 297
- Boiling, cleaning iron by, 261, 262**
- Borings and turnings, cast iron, melting of, 244-247**
 wrought iron and steel, melting of, 247, 248
- Bottom, cutting through of a, 80**
- Bottom doors, 4, 25, 26**
 devices for raising the, 26, 27, 150, 151
 putting up the, 74
 reduction in the size and weight of, 40
 support of, 4
 making up the, 78, 79
 materials for, 77, 78
 of cupola, height of, 25
 pitch or slope of, 80, 81
 plate, 4, 41
 tuyere, 61-64
- Brackets, arrangement of, 39-41**
- Branch pipes, combined area of, 379**
- Briar Hill American Scotch pig, 214**
- Brick, circular, lining of, 128**
 common red, lining, 362
 stack cupolas, old fashioned, 13
- Brown, W. J., furnace of, for melting metals with oils and gases, 176**
- Buffalo blower for cupola furnaces in iron foundries, 415, 416**
 School Furniture Co., cupola of, 70
 explosion at the foundry of, 300, 301
 steel pressure blower, 411-413
- Burned iron in founding, 241-243**
 judging of, 242
- Byram & Co., cupola report of, 284**
- CAGNIARDELLE, 389**
 Carbon, effect of, on cast iron, 259
 free, removal of, from iron, 259, 260
- Carnegie Steel Works, Homestead, Pa., cupolas at, 367, 393**
- Casing, lining of, 6**
 of the modern cupola, 27-29
 strain upon the, 27
- Casings, 4, 5**
- Castings, color of iron in, 451, 452**
 crystalline structure of, 452
 distribution of silicon throughout the, 211
 report of, 287
 selection and mixing of iron by analysis for, 441, 442
 shot iron and hard spots in, 231-235
 sound, clean, 221
- Cast iron, burned, iron produced from, 242**
 fracture of, 241
 constitution of, 222

- Cast iron, effect of carbon on, 259
 indications of the characteristics of, 450
 in founding, 228-231
 metalloids in, 222, 223
 removal of metalloids from, 229
 turnings and borings, melted, 244-247
- Center blast cupola, Ireland's, 312-314
 tuyere, 61, 62
- Chain blast, 389
- Charcoal, experience in melting with, in cupolas, 177, 178
 fuel, 176-178
 iron, cold blast, 204-206
 hot blast, 206, 207
 irons, 204-206
 crystal of, 451
 softening hard iron with, 147-149
 wood for, 178
- Charges and bed, measurement and weight, the best guides for, 196, 197
 placing the, 97-101
- Charging, 95-97
 aperture, location of, 28, 29
 door, 6, 29
 indestructible wire screen, 346, 347
 location of, 146
 flux, 101, 102
 time for, 149, 150
- Chemist and the foundry, 428-434
 duties of a, 447, 448
 practical knowledge required of a, 432
 requirements of a, 430, 431
- Chemistry and cupola practice, 443-447
 failure of the application of, to foundry practice, 429, 430
 in the Foundry, sketch of, by A. E. Outerbridge, Jr., 426-428
 of foundry irons, 424-453
- Chemists, excise-making, 429, 430
 for present needs, 440, 441
 training of, 435-439
- Chenney tuyere, 57
- Cherry Valley American Scotch pig, 214
- Chill mould, damp or rusted, explosion of iron caused by, 298, 299
 pig, 215
- Chipping out, 118-120
- Cincinnati cupola, poor melting in a, 170-172
- Cinder, brittle, making of a, in a cupola, 249
- Clam shells, use of, as flux, 256
- Clay sands for a bottom, 77
- Clays for daubing, 120
 spout linings, 83
- Cleaning iron by boiling, 261, 262
- Coal and wood, bad melting caused by, 169, 170
 anthracite, as a cupola fuel, 178-186
 bituminous, as cupola fuel, 199-201
 charging and melting with, 180-182
 difference in, 179
 fields, hard, regions of, in Pennsylvania, 178, 179
 large, for melting, 182, 183
 melting with, 147
 mine, first, opened in Pennsylvania, 179
 mines, principal, location of, 178
 observations in melting with, 181
 reports showing per cent. of, consumed in melting, 182
 size of, for melting, 182
 small, universal use of, 183
 variation in the per cent. of, consumed, 181
- Coke, Connellsville, quantity of, in the bed, 93
 cupola, 186-199
 custom in the early days of melting with, 190-192
 economy in melting with, 189
 first manufacture of, 186
 shipment of, 186
 forty-eight hour, 192, 193
 good foundry, requirements in the manufacture of, 189, 190
 introduction of, 183, 184
 iron, 207-209
 grading of, 208
 judging the melting qualities of a, 191
 light, inferiority of, 195
 ovens, first coke made in, 186
 per cent. of, to iron, 198
 poor, remedy in melting with, 195
 proportion of, to iron, 97, 195, 196
 seventy-two hour, 192, 193
 variations in the characteristics of, 192
 weights of, required for a bed, 198, 194
- Cold blast charcoal iron, 204-206

- Colliau cupola furnace, standard, 337-340
 cupolas, 337
 plain round cupola, 18, 19
 tuyere, 56
 Combination stick, 110, 111
 Connellsville coal, superiority of, for coke, 188, 189
 coke, first use of, 186, 187
 quantity of, in the bed, 93
 reports of melting with, 198
 cycloidal blower, 396-402
 Ccost of melting, 289-292
 Crandall improved cupola with Johnson patent center blast tuyere, 353-355
 Crane Iron Co., attempt by, to make chemistry available in blast furnace practice, 424, 425
 Cupola accounts, 282-292
 and furnace line, what is new in the, 359-362
 arrangement for supplying blast to the, 37
 banking a, 277-279
 best fuel for a, 173
 supports for a, 24
 Blakeney, 355-357
 book, 291
 bottom, height of, 25
 breast and runner, Moor's patent, 360, 361
 bridged, section through, 124-126
 causes which prevent good melting in a, 271
 charging a, 95-97
 Colliau plain round, 18, 19
 coke, 186-199
 combined tuyere area of a, 65
 common straight, changes in the, 14
 connections of blast pipes with the, 375, 376
 constructing a, 22-44
 Crandall improved, with Johnson patent center blast tuyere, 353-355
 does it pay to slag a? 255, 256
 drop-bottom, 11, 12
 expanding, 308-310
 experimental, 131
 extent of melting zone in a, 92
 for melting tin-plate scrap, 268, 269
 with oil, 174
 foundation, 23, 24
 fuel, anthracite coal as a, 178-186
 bituminous coal as, 199-201
 Cupola fuels, 173-201
 furnace, 1-7
 advantages of, 1
 constitution of a, 2
 fuel required for, 1
 height of the bottom of, 3
 how iron is melted in a, 193
 standard Colliau, 337-340
 support of the lining of, 5
 furnaces, first, used in this country, 8, 9
 foundations of a, 2, 3
 in iron foundries, Buffalo blower for, 415, 416
 shapes of, 2
 sizes of, 2
 Gmelin's, 326-329
 Greiner patent economical, 333, 334
 height of a, 28
 holding a, over night, 276, 277
 molten iron in a, 105
 how to slag a, 254, 255
 importance of the point at which iron is melted in a, 257
 Ireland's, 310-312
 center blast, 312-314
 Jumbo, 349-353
 large stationary bottom, 10, 11
 Mackenzie, 14, 15, 323-326
 management, 73-129
 means of supplying air to a, 389
 melting capacity of a, 29
 of iron in a, 229, 230
 point in a, 130
 zone in a, 140-146
 modern, casing or shell of, 27-29
 double tuyere, 59, 60
 Newton, 340-344
 object of melting iron in a, 218
 old style, 302-305
 English, 307, 308
 on wheels, 357, 358
 Paxson Colliau, 344-347
 truck and track, 357, 358
 placing a blower near a, 384
 practice and chemistry, 443-447
 Pevie, 17, 329-331
 picks, 119, 120
 preparation of a, for a heat, 273, 274
 reports, blanks for, 289
 correct, 289
 false, 289
 requirements for managing a, 274, 275
 reservoir, 305, 306
 scrap, 232

- Cupola scraps, 417-423
 sectional view of, 38, 124-126
 size of heat for a, 45
 slate for charging and cupola report, 288
 space theory of a, 194, 195
 stationary bottom, 307, 308
 Stewart's, 331-333
 tank or reservoir, 320-323
 tap holes in a, 89
 tendency of slag or cinder in a, 250, 251
 theory of melting iron in a, 95
 Truesdale, 16
 tuyeres, 45-72
 two hour, 323-326
 various terms indicating the melting of iron in a, 417
 Voisin's, 314-316
 warming up a, 167-169
 waste heat from a, 366, 367
 weight of slag drawn from a, 251, 252
 what a, will melt, 263-270
 Whiting, 347-349
 with tuyeres near the top, 146
 Woodward's steam jet, 316-320
- Cupolas, approximate height, and size of door for, 29
 bridging over of, above the tuyeres, 116
 Colliau, 337
 common, round, 21
 different styles of, 302-362
 draw front, 9
 experience in melting with charcoal in 177, 178
 for heavy work, 12
 location of tuyeres in, 68, 69
 fluxing of iron in, 249-262
 heights of, 13
 hot blast, 363-367
 improvements in, 8-21
 old fashioned brick stack, 13
 small, location of tuyeres in, 68
 spark catching devices for, 368-374
 steam jet, 334-337
 table of speed and capacities of blowers as applied to, 416
 use of tanks in connection with, in England, 322, 323
 various ways of charging and loading, 130
 with two tap holes, shape of the bottom for, 82
- Cycloidal blower, Connorsville, 396-402
- Cylinder blower, 369
- D**AUBING, 120-122
 substances used for, 120
 thickness of, 124
- Doherty tuyere, 17, 18, 48, 49
- Doors, bottom, 4
 devices for raising the, 74, 75
 dropping the, 76, 77
 props for, 75, 76
 putting up the, 74-76
 sliding, 4
- Double tuyere, 57, 58
- Draw-front cupolas, 9
 objection to, 10
- Drop bottom, 2
 cupola, introduction of, 11, 12
- Dross, 231
- Drying the lining, 73, 74
- Dump, breaking up the, 116, 117
 collection of shot from the, 232
 constitution of the, 116
 picking over the, 117, 118
 removing, 117, 118
 iron from the, 118
 room for the removal of, 25
- Dumping, 115-117
- Dumps, recovery of iron from, 235-241
- E**LECTRIC steel-pressure blowers, 409-411
- Elevators, 23
- England, use of tanks in, in connection with cupolas, 322, 323
- English cupola, old style, 307, 308
- Examples of bad melting, 152-172
- Expanded tuyere, 47, 48
- Expanding cupola, 308-310
- Experiments in melting, 130-151
- Explosion of molten iron, 296-301
- Explosions in blast pipes, 387
- F**AN blowers, 406-416
- Ferro silicon iron, melting shot iron with, 240, 241
- Fire brick for lining, 37
 split, 128, 129
 clay, absorption of water by, 121
- Flasks, collection of shot and other scrap from the top of, 232
- Fluor spar, use of, as a flux, 260, 261
- Flux, charging of, 101, 102
 definition of, 249
 distribution of, 101
 effect of, upon iron, 252
 for melting tin-plate scrap, 269
 quantity of, 101
- Fluxes, action of, on lining, 253

- Fluxes, substances used as, 249
 Fluxing of iron in cupolas, 249-262.
 Foundation, cupola, 23, 24
 Foundations of cupola furnaces, 2, 3
 Founders, trick of, 207
 Founding, burned iron in, 241-243
 cast iron in, 228-231
 Foundries, difficulties in, 271, 272
 Foundry and chemist, 428-434
 chemist, duties of a, 447, 448
 chemistry, 425, 426
 chemists, training of, 435-439
 dumps, recovery of iron from, 235-241
 iron, indications of fracture in, 448-453
 investigation of, 428
 proportion of silicon in, 211
 irons, 202-217
 chemistry of, 424-453
 melting and mixing, 218-248
 managers, technical training for, 439, 440
 pig, 215
 practice, failure of the applica-
 tion of chemistry to, 429, 430
 refuse, machine for the recovery
 of iron from, 232, 233
 scrap, 232
 Fracture, indications of, in cracks or
 breaks, 452
 foundry
 iron, 448-
 453
 value of, 451
 Front, 86-88
 material used for putting in the,
 86, 87
 thickness of, 87
 Fuel, 107-109
 amount of air required for the
 combustion of, 391
 for each charge, 96
 required for various
 furnaces, 1
 anthracite coal as, 178-186
 best, for a cupola, 173
 bituminous coal as, 199-201
 charcoal, 176-178
 charging a cupola with, 95
 coke as, 186-199
 distribution of the charge of, 98
 division of, into charges, 294
 for bed and charges, determina-
 tion of the proper amount
 of, 197
 lighting up, 91
 gas and liquid, 173-176
 Fuel, measuring of, 290
 proportion of, to iron, 195, 196
 under the tuyeres, 138, 139
 weighing of, 290
 weight of, required for a bed, 94
 Fuels, cupola, 173-201
 mixed, 184, 185
 Furnace, blast, fuel required for, 1
 cupola, fuel required for, 1
 for melting metals with oils and
 gases, 176
 pot, fuel required for, 1
 puddling, 229
 reverberatory, fuel required for, 1
 Furnaces, blast, 202-204
 producing anthracite iron, loca-
 tion of, 209
 various, fuel required for, 1
 GALVANIZED sheet iron scrap,
 G melting of, 268
 Gangway scrap, 232
 shot, restoration of, 233
 Garden City positive blast blowers,
 405, 406
 Gas and liquid fuel, 173-176
 house coke, 189
 Gauges, air or blast, 387-389
 Glover, Thomas, experiments of, with
 steam jet cupolas, 335
 Gmelin, Dr. Otto, cupola of, 326-329
 Gould & Eberhardt, scaffold in the
 foundry of, 44
 Green patented positive pressure
 blower, 396
 Greiner patent economical cupola,
 333, 334
 tuyere, 60
 Grouting for lining, 37
 HEAT escaping from a cupola, util-
 ization of, 366, 367
 size of a, for a cupola, 45
 taking the blast off during a,
 276, 277
 utilization of, 273
 waste, from a cupola, 366, 367
 utilization of, 1, 2
 High silicon iron, 210-213
 Southern iron, 258, 259
 Hocking Valley coke, 188
 Horizontal and vertical slot tuyere,
 51, 52
 Hot blast charcoal iron, 206, 207
 cupolas, 363-367
 ovens, 366

- I**RELAND'S center blast cupola, 312-314
 cupola, 310-312
 tuyeres in, 59
- Iron**, action of the, changed by the pitch of the bottom, 81
 additional charging of, 100
 amount of, for each charge, 96
 lost in melting, 257, 258
 anthracite, 209, 210
 broken when in a semi fluid state, appearance of, 452, 453
 burned, change in the nature or quality of, 243
 in founding, 241-243
 judging of, 242
 burning of, in melting, 221, 222
 cast, effect of carbon on, 259
 in founding, 228-231
 metalloids in, 222, 223
 charging a cupola with, 95
 of, before blast is put on, 103, 104
 cleaning of, by boiling, 261, 262
 coke, 207-209
 cold, wet or rusted, explosion of molten iron caused by, 297, 298
 combination of, with metalloids, 230, 231
 division of, into charges, 294
 dull, cause of, 145
 effect of different mineral and chemical substances upon, 257-260
 flux upon, 252
 silicon on, 258, 259
 equal grade of, throughout a heat, 218, 219
 failure in mixing, by analysis, 429
 first charge of, variations in the weight of, 97
 fuel used, in smelting, 176
 melted, flow of, 113
 fluxing of in cupolas, 249-262
 foundry, indications of fracture in, 448-453
 from rusted shot, 239
 grades of, from remelted shot-iron, 237
 grading and mixing of, by analysis, 441-443
 hard, softening of, 147-149
 high silicon, 210-213
 crystal of, 451
 Southern, 258, 259
 hot, definition of, 220
 for light work, 87
- Iron**, importance of the point at which melted in a cupola, 257
 in castings, color of, 451, 452
 machine for recovery of, from foundry refuse, 232, 233
 melting, large pieces of, 264, 265
 of, in a cupola, 229, 230
 puddling furnace, 229
 mixing various grades of, 219, 220
 molten explosion of, 296-301
 holding of, in a cupola, 105
 object of melting of, in cupola, 108, 218
 ore containing silicon, iron produced from, 210, 211
 oxidized, 241
 per cent. of coke, to, 198
 placing the, in the cupola, 98
 proportion of charges of, to coal and coke, 97
 coke to, 195, 196
 rapid melting of, 219
 recovery of, from foundry dumps, 118, 235-241
 retention of metalloids in, 230
 rusted, 241
 silver gray, 210
 crystals of, 450
 spilled, 231
 theory of melting, in a cupola, 95
 time for melting of, 149, 150
 tuyeres to improve the quality of, 71
 various terms indicating the melting of, in a cupola, 417
 very hard, appearance of the fresh fracture of, 450
- Irons**, appearance of the fractures of, 450
 charcoal, 204-206
 charcoal, crystal of, 451
 designations of, 203, 204
 foundry, 202-217
 chemistry of, 424-453
 melting and mixing, 218-248
 mixing of, 224-228
 in charging, 99
 pig, 215-217
 prevention of the hardening of, by shot iron, 234
- J**AGGER, Treadwell & Perry, hot blast cupolas constructed by, 363-365
- Jumbo** cupola, 349-353

- K**ISH, definition of, 214
 Knoepfel, Mr., on banking a cupola, 277-279
- L**ACKAWANNA coal, example of charging and melting with, 180
 Ladle, damp, boiling of iron caused by, 301
 Lawrence cupola, 16, 17
 reducing tuyere, 53, 54
 Leather bellows, 389
 Lebanon Stove Works, daily report of Foundry Department of, 285
 Lighting up, 91, 92
 Limestone, action of, upon lining, 253
 amount of, required, to produce a fluid slag, 251
 charging of, 254
 use of, as flux, 249-252
 in large quantities, 250-252
- Lining, 37-39
 absorption of moisture by, 41
 action of fluxes on, 253
 angle iron for the support of, 39
 application of daubing to a, 122
 bracket for the support of, 39
 burning out of, 40, 128
 common red brick, 362
 destruction of, at and below the tuyeres, 127
 drying the, 73, 74
 false, 128
 filling in of the, at the melting zone, 123
 grouting for, 37
 materials for, 6, 7, 37
 mica schist, 361
 mortar for, 37
 of circular brick, 128
 point of greatest wear on, 127
 projection or hump on the, over the tuyeres, 119
 setting of, 37
 shaping the, 122-127
 taper from the bosh to the, 126
 taper of, 123
 thickness of, 7, 127
 daubing on the, 124
- Linings, new, 122
 Loams for bods, 111
 Low tuyeres, 139, 140
- M**CCORMICK, P., and Campbell, J., first coke made by, 186
 Mackenzie cupola, 14, 15, 323-326
 objectionable features of, 15
- Mackenzie tuyere, 49, 50
 Malleable iron, experiments in the manufacture of, 257
 Marble spalls, 256, 257
 Marsh, James, Lewisburg, Pa., explosion of molten iron in foundry of, 290
 Melter, duties of a, 275
 give the, a chance, 279-281
 practical, requirements of a, 444
 skill of the, seen at the tap-hole, 114, 115
- Melters, excuse-making, 430
 older, superstition of, 76
- Melting, 103-106
 account, 290
 and mixing foundry iron, 218-248
 art in, 271-281
 bad, at a West Troy Stove Works, 161-166
 caused by wood and coal, 169, 170
 examples of, 152-172
 illustration of, 170-172
 basis of the theory of, 444, 445
 best practical results for, for general foundry work, 421
 blast in, 389-394
 calculating the cost of, per ton, 291, 292
 commencement of, 103
 cost of, 289-292
 experiments in, 130-151
 fast, cupola required for, 272, 273
 or slow, 20
 fuel required for, 107
 iron in a cupola, various terms indicating the, 417
 large pieces of iron, 264, 265
 most even, 144
 important point in, 446
 no chance work in, 272
 point, 92
 in a cupola, 130
 manner of finding the, 93
 to guard against in, 447
 poor, cause of, 101
 in a Cincinnati cupola, 170-172
 refuse from, removal of, 10
 theory of, in the old cupolas, 391
 tin plate scrap in a cupola, 266-270
 trouble in, after a cupola has been newly lined, 94
 with coal, 147
 oil, experiments in, 152

- Melting with wet or superheated steam**, 336, 337
zone, 92, 140-146
 development of, 146
 filling in the lining at the, 123
 location of a, 140
 no iron melted outside the, 145
 raising of the, 141
- Mercury gauges**, 387
- Metalloids, combination of, with the iron**, 230, 231
 in cast iron, 222, 223
 occurrence of, 228
 prevention of the separation of, 231
 removal of, from cast iron, 229
 retention of the, 230
- Metals, furnace for melting, with oils and gases**, 176
- Mica schist lining**, 361
- Mixing irons**, 224-228
- Moor's patent cupola breast and runner**, 360, 361
- Mortar for lining**, 37
- Moulder, aim of every**, 275
- Moulding sand for daubing**, 120
 spout lining, 82
- NEWTEN cupola**, 340-344
 North Bros., Philadelphia, Pa.,
 explosion of molten iron in
 foundry of, 299, 300
- OIL**, experiments in melting with,
 152, 174-176
- O'Keefe, J.**, spark catching device
 designed by; 371-373
- Ohio coal, coke from**, 188
- Old Mine Lehigh coal, example of
 charging and melting with**, 181
- Oliphant, F. H.**, early production of
 coke by, 186
- Outerbridge, A. E., Jr.**, sketch of
 Chemistry in the Foundry by, 426-
 428
- Oval tuyeres**, 47
- Oyster shells, use of, as flux**, 256
- PARIS, Daniel E., & Co.**, trouble
 with the cupolas in the works
 of, 161-166
- Paxson-Colliau cupola**, 344-347
 truck and track cupola, 357, 358
- Peep holes**, 138
- Pennsylvania Diamond Drill and
 Manufacturing Co.**, cupola of,
 61
- Pennsylvania hard coal fields, re-
 gions of**, 178, 179
 location of principal coal mines
 in, 178
- Perry & Co.**, trouble with the cupo-
 las in the works of, 152-160
- Pevie cupola**, 17, 329-331
- Picks**, 119, 120
- Pig, American-Scotch**, 214
 and old scrap, melting of, 100
 cast, 203
 chilled, 203
 foundry, 215
 freshly broken, indications of the
 fracture of, 449, 450
 iron, terms for, 202
 irons, 215-217
 for foundry work, percentage
 of silicon in, 212
 melting of, with remelt scrap, 99
 of different grades, charging of,
 99
 placing the, in the cupola, 97, 98
 sandless, 203, 216, 217
 Scotch, 213, 214
- Piston blower**, 389
- Pit for the removal of the dump**, 25
 lining of, 3
 of cupola furnace, 3
- Pittsburg coke**, 187
- Poking the tuyeres**, 106
- Pot furnace, fuel required for**, 1
- Prop, support for the**, 4
- Props for doors**, 75, 76
 removal of, 76, 116
- Providence Locomotive Works, visit
 to the plant of**, 167-169
- Puddling furnace**, 229
- RANSOM & Co.**, hot blast furnace
 at the foundry of, 365, 366
- Reeder, Chas., & Sons**, cupolas in the
 works of, 8, 9
- Relining and repairing**, 127-129
- Reservoir cupola**, 305, 306
- Return flux cupola spark catcher**,
 371-373
- Reverberatory furnace, fuel required
 for**, 1
- Reversed T tuyere**, 52
- Root's rotary pressure blower**, 403-405
- Round tuyere**, 46, 47
- SAND bottom**, 77-82
 Sand bottom, destruction of, by
 molten metal, 79
 height of tuyeres above,
 35, 65, 66

- Sand bottom, reuse of, 118
 for the bottom, working of, 80
 mould, wet, explosion of iron
 caused by, 298, 299
 pig, 215
- Sandless pig, 216, 217
- Scaffold, 22, 23
 construction of, 7, 10, 42
 fire proofing of, 42
 in a Detroit foundry, 43
 location of, 7, 41, 42
 size of, 7
- Scaffolds, fire proof, 41-44
 iron, 43, 44
- Scales and their use, 293-295
- Schuykill coal and Connellsville
 coke, mixed, heats melted
 with, 184, 185
 coal, example of charging and
 melting with, 180, 181
- Scotch pig, 213, 214
- Scrap and high silicon pig, melting
 of, 212
 galvanized sheet iron, melting
 of, 268
 sheet iron, melting of, 268
 wrought iron, 243, 244
- Shaping the lining, 122-127
- Sharon Iron Co., use of bituminous
 coal by the, 200, 201
- Sheet blast tuyere, 49
- Shell of the modern cupola, 27-29
- Shells, 256
- Shot iron, 232
 and hard spots in castings,
 231-235
 collection of, 232
 device for melting, 234, 236
 experiments in melting, 238,
 239
 gangway, restoration of, 233
 hardening of, 233
 melting of, 234, 236, 237
 with a ferro-silicon
 iron, 240, 241
 prevention of the hardening
 of other irons by, 234
 remelted, grades of iron from,
 237
 rusted, iron from, 239
- Silicon, distribution of, throughout
 the castings, 211
 effect of, on iron, 258, 259
 occurrence of, 210
 percentage of, in pig irons, 212
 pig, high, and scrap, melting
 of, 212
 proportion of, in foundry iron, 211
- Silver gray iron, 210
- Skinner Engine Co., Erie, Pa., ex-
 plosion in the cupola of, 300
- Slag, absorption of impurities by, 102
 chilling of, 90
 composition of, 252
 flow of, 67
 fluid, amount of limestone re-
 quired to produce, 251
 hole, 89, 90, 254, 255
 front, 90
 location of, 33
 or cinder in a cupola, tendency
 of, 250, 251
 tapping of, 90
 time for drawing, 255
 weight of, drawn from a cupola,
 251, 252
- Slagging, estimate of the cost of,
 255, 256
- Sledging, bars for, 109
- Sliding doors, 4
- Soapstone for daubing, 120
- Softening hard iron, 147-149
- Spark arrester, modern, 364-371
 catcher, return flue cupola, 371-
 373
 catching device, best, 374
 devices for cupolas, 368-374
- Spout, 32, 33, 82-85
 bottom of, 85
 fall of, 82
 lining, greatest strain upon the,
 84, 85
 materials for, 82, 83
 melting of, 85
 modern, 82
 old way of making a, 82
 wet, explosion of iron caused by,
 296
- Stack casing, 2, 5
 contracted, 5
 height of, 5
 lining, 39
 support of the lining of, 5
- Stationary bottom cupola, 307, 308
- Steam jet cupola, Woodward's, 316-320
 cupolas, 334-337
 wet or superheated, melting
 with, 336, 337
- Steel and wrought iron turnings and
 borings, melting of, 247, 248
 pressure blower, Buffalo, 411-413
 blowers, 407, 408
 electric, 409-411
 on adjustable bed, with
 combined upright en-
 gine, 408, 409

Steel spring gauges, 387
 Stewart's cupola, 331-323
 Stopping in, 110
 and tapping, 112-115
 knack in, 114
 Straight Line Engine Co., scaffold in
 the foundry of, 44
 Straw for lighting up, 91
 Sturtevant blowers, 406-411
 Syracuse Stove Works, melting sheet
 of, 286

TABLE of speeds and capacities of
 blowers as applied to cupolas, 418
 showing the diameter and area
 of pipes, 379
 necessary increase in
 diameter for the dif-
 ferent lengths of
 pipes, 378

Tank or reservoir cupola, 320-323
 Tanks, use of, in England, in connec-
 tion with cupolas, 322, 323

Tap hole, 31, 32
 flow of iron from the, 105
 reduction in the size of, 104,
 105
 skill of the melter seen at
 the, 114, 115
 holes, locating the, 88, 89
 sizes of, 88

 making the, 113, 114

Tapping and stopping in, 112-115
 bar, explosion of iron caused by,
 297

 bars, 109, 110

Taylor, J., first coke made by, 186

Technical training for foundry man-
 agers, 439, 440

Tin plate scrap, quality of the metal
 from, 266, 267
 melting of, 266-270
 recovery of, from iron, 266

Treat, C. A., remarks of, 422

Triangular tuyere, 54

Truesdale cupola, 16

 reducing tuyere, 52, 53

Tumbling barrel scrap, 232

Turnings and borings, cast iron, melt-
 ing of, 244-247
 wrought iron and
 steel, melting of,
 247, 248

Tuyere, adjustable, 359
 area, combined, of a cupola, 65
 Blakeney, 50, 51
 bottom, 61-64
 boxes, 71, 72

Tuyere, center blast, experiments
 with, 393, 394

Chenney, 57

Colliau, 56

Doherty, 48, 49

double, 57, 58

expanded, 47, 48

Greiner, 60

height of, 65-69

holes, 5

horizontal and vertical slot, 51,
 52

Lawrence reducing, 53, 54

Mackenzie, 49, 50

oval, 47

reversed T, 52

round, 46, 47

sheet blast, 49

small, mistake of, 65

triangular shaped, 41, 54

Truesdale reducing, 52, 53

water, 55, 56

Whiting, 56

Tuyeres, 34-36, 45-72

 adjustable, 60, 61

 best way of connecting blast
 pipes with, 382-384

 connection of belt air chamber
 with the, 382

 direct connection of blast pipes
 with, 380

 double row of, 19, 20

 experiments with, 66

 fuel under the, 138, 139

 height of, above sand bottom, 35

 high, reasons given in favor of,
 66, 67

 in Ireland's cupola, 59

 location of, 34

 upper row of, 36

 low, 139, 140

 weight of coke with, 196

 number of, 34, 69

 poking of, 106

 projection or hump on the lining
 over the, 119

 shape of, 70, 71

 size of, 64, 65

 three rows of, 58-60

 to improve the quality of iron, 71

 two or more rows of, 36, 37

UNITED States, anthracite coal
 mines in, 178

VENTS, restoration of, 233
 Voisin's cupola, 314-316

- W**ARMING up a cupola, 167-169
 Waste heat, utilization of, 1, 2
Water blast, 389
 cylinder blast, 389
 gauges, 387
 muddy, explosion of iron caused by, 299
 tuyere, 55, 56
West, Thos. D., controversy with, 434, 435
 experiments of, with center tuyere, 63, 64
 reports of melting with Connellsville coke given by, 198
Whiting cupola, 347-349
 Whiting tuyere, 56
Wood and coal, bad melting caused by, 169, 170
 for charcoal, 178
Woodward's steam jet cupola, 316-320
Wrought iron and steel turnings and borings, melting of, 247, 248
 scrap, 243, 244
- Z**ONE, melting, 92, 140-146
 development of, 146
 location of a, 140
 no iron melted outside the, 145
 raising of the, 141

