

SCIENTIFIC AMERICAN

[Entered at the Post Office of New York, N. Y., as Second Class Matter.]

A WEEKLY JOURNAL OF PRACTICAL INFORMATION, ART, SCIENCE, MECHANICS, CHEMISTRY AND MANUFACTURES.

Vol. XLIII.—No. 18.
[NEW SERIES.]

NEW YORK, OCTOBER 30, 1880.

[\$3.20 per Annum.
POSTAGE PREPAID.]

LEVELING ATTACHMENT FOR EARTH CARS.

Our engraving represents a simple and effective attachment for leveling the earth dumped from the cars of a construction train. The car carrying the apparatus must of necessity be the last in the train, and as it is moved forward, all of the earth discharged by the train is very quickly leveled, saving a great deal of manual labor and doing the work more perfectly than it can be done in the ordinary way.

Fig. 1 is a perspective view of the apparatus in working order; Fig. 2 is a partial plan view; and Fig. 3 is a detail view of the pawl and ratchet which holds the parts in working position.

To the forward end of a platform car are attached two strong wings, A, which are constructed either entirely of iron or of wood iron clad. The pivots upon which these wings turn are made rigid by braces, and each wing is supported by two horizontal braces, B, carrying racks, which are engaged by pinions whose shafts, C, are journaled in the body of the car, and provided with a pawl and ratchet for holding them in any desired position. The forward braces, B, are each provided with a pinion, pawl, and ratchet, while the rear braces are operated by a pinion common to both. All of the pinion shafts are squared to receive a socket wrench provided with a wheel by which the shaft may be turned so as to spread the wings as much as may be required, when they will be held by the pawls and ratchets, and the earth on each side of the track will be spread out and leveled as the car is drawn forward after the discharging of the train. As soon as the leveling is completed the wings are drawn closely against the car,

and the wrenches are removed when the car is used like any other flat car.

The wings are arranged so that they may be readily removed from one end of the car and attached to the other. The forward end of the wing is inclined inward toward the middle of the track, so as to remove the earth from the vicinity of the track and from the ends of the ties.

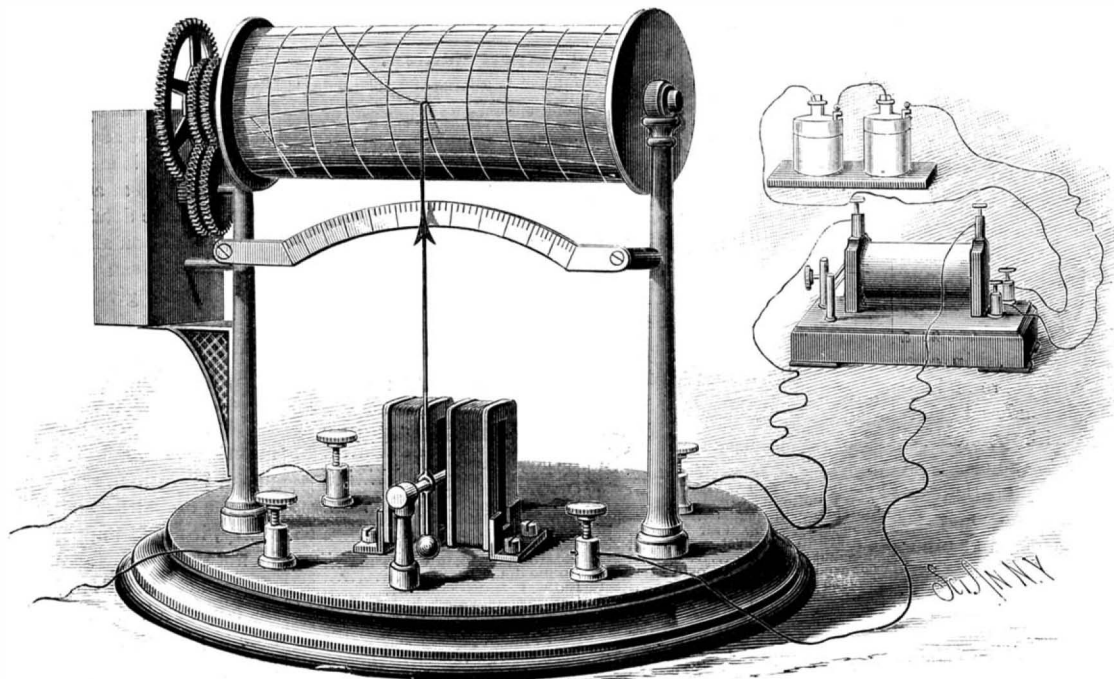

RECORDING GALVANOMETER.

NEW RECORDING GALVANOMETER.

BY GEO. M. HOPKINS.

In making galvanometric tests it is often desirable to consider the element of time, but, as every electrician knows, to do this with the ordinary appliances is tiresome, and the result is liable to be inaccurate.

The extreme delicacy of the action of the galvanometer renders it difficult to apply to it any device capable of recording the movements of the needle without interfering more or less with its action. Only two methods of making the record have presented themselves to the writer—one contemplates the use of photography; the other, the application of a disruptive spark from an induction coil. The former is considered too slow; the latter has been adopted and applied to an ordinary vertical galvanometer in the manner indicated in the engraving. The helixes are wound with rather coarse wire (No. 22). The needle is astatic, the inner member swinging in the central opening in the helixes in the usual way, the outer member being located behind the helixes. The arbor supporting the needle has very delicate pivots, and carries a long aluminum index, which is counterpoised so that it assumes a vertical position when no current passes through the helixes, and the needle is unaffected by terrestrial magnetism.

This invention, in the construction and repair of railroads, must prove a valuable acquisition to the means already in use for facilitating the heavy work of railroad construction.

Further information may be obtained by addressing the patentee, Mr. James Andrews, of Biddeford, Me.

The upper end of the index swings in front of a graduated scale, and is prolonged so as to reach to the middle of the cylinder carrying a sheet of paper upon which the movements of the needle are to be recorded. This cylinder is of brass, and its journals are supported by metal columns projecting from the base upon which the other

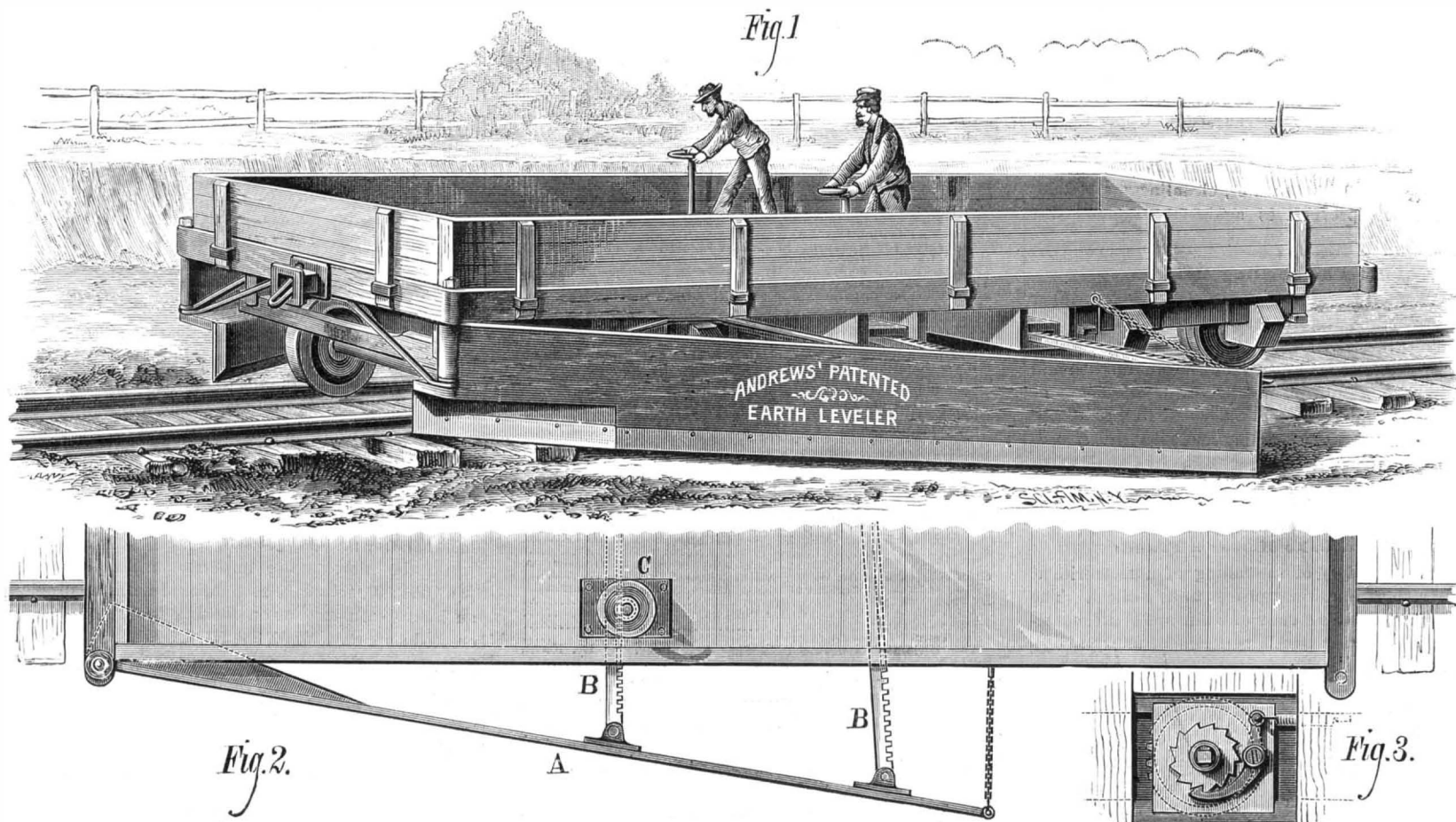

ANDREWS' LEVELING ATTACHMENT FOR EARTH CARS.

parts of the instrument are mounted. The scale is supported by vulcanite studs projecting from the columns, and to one of the columns is attached a clock movement provided with three sets of spur wheels, by either of which it may be connected with the arbor of the cylinder. One pair of wheels connects the minute hand arbor of the clock with the cylinder, revolving the cylinder once an hour; another pair of wheels connect the hour hand mechanism with the cylinder, so that the latter is revolved once in twelve hours; while a third pair of wheels give the cylinder one revolution in six days.

This instrument is designed especially for making prolonged tests of different batteries in order to determine their characteristics. It is provided with four binding posts, two of which connect the wires of the batteries under test with the helixes. The other binding posts are connected respectively with the posts supporting the needle and with the journals of the recording cylinder. These posts receive wires from an induction coil capable of yielding a spark from one-eighth to one-quarter inch long.

The induction coil is kept continuously in action by two Bunsen elements, and a stream of sparks constantly pass between the elongated end of the index and the brass cylinder, perforating the intervening paper and making a permanent record of the movement of the needle. To render the line of perforations as thin as possible, the end of the index is made sharp and bent inward toward the cylinder. The spur wheels are placed loosely on the arbor of the cylinder, and the boss of each is provided with a set screw by means of which it may be fixed to the arbor. This arrangement admits of giving to the cylinder either of the speeds, as may be required.

The paper upon which the record is to be made is divided in one direction into degrees and in the other into hours and minutes. The hour and minute lines are curved to coincide with the path of the end of the index. The greatest strength of current being indicated by the greatest deflection from the central line of the record sheet, the approach of the index toward the central line indicates a diminution of the current, which is faithfully recorded by the passing sparks.

These records may be duplicated by using the sheet as a stencil and employing the method of printing used in connection with perforating pens. When the tests are of long duration the action of the induction coil is rendered intermittent by an automatic switch connected with the clock.

This method of recording may be applied to the electrical dynamometer, to electric meters, and to the more delicate galvanometers; and substantially the same device may be applied to recording thermometers, barometers, and other delicate meteorological instruments.

A New Ferry House.

The Hoboken Ferry Company have in process of construction at the terminus of the Delaware, Lackawanna, and Western Railroad, at Hoboken, a new ferry house, which, from its quaint, Queen Anne style of architecture, attracts considerable attention. The roof presents the curious appearance of being covered with snow. This is produced by the use of H. W. Johns' asbestos roofing, which is being extensively employed on factories and public buildings throughout the country. The snow-white roof, in contrast with the brilliant color of the walls of the new ferry house, gives a striking and showy effect to the structure.

M. DE LESSEPS does not believe in the efficacy of quarantines. He recalls that in 1834-5 in Egypt, although the foreign consuls managed the quarantine on the coast, they were unable by the most severe precautions to prevent the introduction and development of the worst plague that ever ravaged the Orient, carrying off in eight months one-third the population of Lower Egypt, particularly around Alexandria and Cairo, while it made no victims in Upper Egypt, although there was daily communication between the two parts of the country. He believes that sanitary precautions, improvement of food, air, and water, cleanliness, and temperance are the best preventives against contagious diseases.

Dr. Holmes on Spelling Reform.

Dr. Oliver Wendell Holmes says, in a letter to a member of the English Spelling Reform Association: I should not care to be an obstructive (if I could be) in the way of any well organized, scholarly attempt to reform our English and American language. But you must allow a fair share of old square-toed prejudices in their personal likings to old square-toed people. I hate to see my name spelled *Homes*, yet I never pronounce the *l*. I know from old Camden that its derivation is from the word *holm*, and I want the extra letter.

The Schroon Lake Meteor a Fraud.

The circumstantial story of the falling of a meteorite at Schroon Lake a short time since proves to be a cheat. The alleged meteorite is simply a mass of white quartzite, somewhat weathered, inclosing small particles of mica, a common stone in the Adirondack region.

FOLLOWING the example of the Baldwin Locomotive Works, the first to introduce the Tanite Company's improved surface grinder for perfecting locomotive slide-bars, the Danforth Locomotive Works have recently ordered one of the same machines for their establishment. The Tanite Company are also busy filling an order for several tons of emery wheels for the French Government.

Scientific American.

ESTABLISHED 1845.

MUNN & CO., Editors and Proprietors.

PUBLISHED WEEKLY AT NO. 37 PARK ROW, NEW YORK.

O. D. MUNN. A. E. BEACH.

TERMS FOR THE SCIENTIFIC AMERICAN.

One copy, one year postage included. \$3 20 One copy, six months, postage included 1 60

Clubs.—One extra copy of THE SCIENTIFIC AMERICAN will be supplied gratis for every club of five subscribers at \$3.20 each; additional copies at same proportionate rate. Postage prepaid.

Remit by postal order. Address MUNN & CO., 37 Park Row, New York.

To Advertisers.—The regular circulation of the SCIENTIFIC AMERICAN is now Fifty Thousand Copies weekly. For 1880 the publishers anticipate a still larger circulation.

The Scientific American Supplement

Is a distinct paper from the SCIENTIFIC AMERICAN. THE SUPPLEMENT is issued weekly. Every number contains 16 octavo pages, uniform in size with SCIENTIFIC AMERICAN. Terms of subscription for SUPPLEMENT, \$5.00 a year, postage paid, to subscribers. Single copies, 10 cents. Sold by all news dealers throughout the country.

Combined Rates.—The SCIENTIFIC AMERICAN and SUPPLEMENT will be sent for one year, postage free, on receipt of seven dollars. Both papers to one address or different addresses, as desired.

The safest way to remit is by draft, postal order, or registered letter. Address MUNN & CO., 37 Park Row, N. Y.

Scientific American Export Edition.

THE SCIENTIFIC AMERICAN Export Edition is a large and splendid periodical, issued once a month. Each number contains about one hundred large quarto pages, profusely illustrated, embracing: (1.) Most of the plates and pages of the four preceding weekly issues of the SCIENTIFIC AMERICAN, with its splendid engravings and valuable information; (2.) Commercial, trade, and manufacturing announcements of leading houses. Terms for Export Edition, \$5.00 a year, sent prepaid to any part of the world. Single copies 50 cents. (3.) Manufacturers and others who desire to secure foreign trade may have large and strikingly displayed announcements published in this edition at a very moderate cost. The SCIENTIFIC AMERICAN Export Edition has a large guaranteed circulation in all commercial places throughout the world. Address MUNN & CO., 37 Park Row, New York.

NEW YORK, SATURDAY, OCTOBER 30, 1880.

Contents.

(Illustrated articles are marked with an asterisk.)

Table listing various articles such as Agricultural inventions, Air, open, for consumptives, Astronomical notes, Balloon photography, Blanket brigade, Breakbone fever in the South, Chimney cap and ventilator, Color blindness in freling, Comet, the, in Pegasus, Consumptives, open air for, Dowd tunneling system, Elephants, rare, Elevated railway for Costa Rica, Elevated railways, history of, Fan-tailed poodle, Fence, wire, toothed-wheel, Ferry house, new, Fire damp, destroying, Gable, the, of science, Galvanometer, recording, new, Croto under Mount Rossi, Gun, hammerless, Hammerless gun, Hammer, 20-ton, Pittsburg's, Helium, Yale's, Homicide in the United States, Hose pipe nozzles, Ice and cold, production of, Ice, hot, Inventions, agricultural, Inventions, mechanical, Inventions, new, Levelling attachment for cars, Lowell mills burned, Mechanical inventions, Meteor fraud, Schroon Lake, Motor, simplex, Davey's, Mountains of North Carolina, Notes and queries, Nursery chair, improved, Ocean temperatures, Oil fires, cause of, Oil wells, shooting, Oysters, destruction of, Paper making in China, Pear trees, blight of, Photography, balloon, Poodle, fan-tailed, Potatoes, dried, in California, Public domain, the, Railway, trans-Sahara, Railway, elevated, history of, Railway, horse, in Europe, Railway, sinking, another, Rain falling, electric charges of, Recording galvanometer, new, Rubber instruments, preserving, Science, the, table of, Slugs, invaded by, Spelling reform, Dr. Holmes on, Spirits, distillation of, Spur, the electrical, Stars, twinkling of the, Telegraphic progress, recent, Telephone, the, on the battlefield, Thread from wood, Tin in Maine, Transfusion of blood, Tunneling system, Dowd's, Turpentine, etc., Vinegar, good, What we buy and sell abroad, Wire fence, toothed-wheel.

TABLE OF CONTENTS OF

THE SCIENTIFIC AMERICAN SUPPLEMENT

No. 252,

For the Week ending October 30, 1880.

Price 10 cents. For sale by all newsdealers.

Table listing contents of the supplement with page numbers. I. ENGINEERING AND MECHANICS.—Cold Air Machines, The English 100-Ton Gun, Safety hooks, Apparatus for Measuring Strains in Structures, How to Make a Telescope, Apparatus for measuring strains, II. CHEMISTRY AND TECHNOLOGY.—Apparatus for Continuous Distillation System, The India-Rubber and Gutta Percha Industries, Dental rubber, Preparation of Opium for Smoking, Freezing Mixtures, Compression of Gaseous Mixtures, A New Triamidotriphenylmethane, Fischek and J. Ziegler, Ethereal Oil from the California Bay Tree, Abietic Acid, Valuation of Bituminous Rocks and Limestones, III. HYGIENE, MEDICINE, ETC.—Constant Bath Treatment of Fever, The Cure of Constitutional Diseases by the Use of Glasses, A clinical lecture by Dr. D. B. ST. JOHN ROOSA, Danger from Contagious Diseases Affecting the Lower Animals, A Lesson on Curare and Other Poisons, Effects of Inhaling Oxygen, Dr. Tanner's Lectures, The Ultimate Structure of Living Organisms, IV. ELECTRICITY, ETC.—Atmospheric Electricity, A Florida Typhoon, V. THE AMERICAN PHARMACEUTICAL ASSOCIATION, 28th ANNUAL MEETING, VI. ASTRONOMY.—The Earth as Seen from Other Stars, The earth as seen from Mercury, The earth as seen from Venus, The earth as seen from the moon, The earth as seen from Mars, The earth as seen from Jupiter, VII. HORTICULTURE, ETC.—A New York Orchard, Remedy for the Cabbage Worm.

THE TELEPHONE ON THE BATTLEFIELD.

The development of the telephone has been so rapid and so recent that it has not yet been extended to all the fields of usefulness for which it is destined. Thus we believe it has not only never been used in actual battle, but it has had few if any opportunities to show its capacity even upon the fields of mimic war, Grand Army reviews, and mock battles. Yet it is evident that no more important use could be found for it than a great commander could make in a general engagement. In these days when a plan of battle includes the management of three or four great armies on each side, all under one head but scattered over wide areas and separated from each other by great distances, it is necessary that the commander-in-chief should have the most rapid communication with his different corps commanders, and be able to judge of the situation at any given point by reports instantaneously conveyed. In recognition of the importance of this necessity there are signal corps and telegraph brigades attached to the army staff of all great countries, but up to the present time they do not seem to have appreciated the telephone sufficiently to make it an important part of their equipment.

A means of conveying information, instructions, and orders rapidly and accurately during an engagement cannot be too highly regarded. The field telegraph was a long step in the right direction, but telegraphic messages are open to many objections which would be wholly avoided by the use of the telephone. Of course it may be taken for granted that the electric wire will hereafter be in general use on the battlefield, but the transmission of words letter by letter is necessarily slow and uncertain compared with the ease of communication by word of mouth; hence the telephone affords a great advantage to the general having it available for use. He is able to learn in a moment the exact condition of affairs at any quarter of the field. Not only can he communicate detailed instructions and receive specific information upon all points bearing upon the attack and defense, but he can gather some knowledge of the state of affairs at any given point, even though there may be no officer present at that point having the experience and judgment necessary for forming a proper estimate of the condition of affairs. The telephone, conveying the sounds of the battle, would enable the general to determine by the character and rapidity of the fire at that point how serious the situation was. Again, if a general of division defending an important position far distant on the flank should be killed, and the casualties among the brigade commanders should be heavy, it might happen that the senior officer living might be not sufficiently acquainted with the field, or not of wide experience enough to handle properly the force left under his command. In such a case the general-in-chief would be able to give all necessary instructions and orders direct from headquarters.

Moreover, this instrument cannot fail to diminish the danger to the general in command. It will not be necessary for him to advance to points under fire in order to confer with his corps commanders. Of course no general would hesitate to expose himself wherever the necessity existed for so doing, but inasmuch as the fate of an army may depend upon the life of the commander, it is desirable to reduce to the minimum the possibility of his sudden taking-off. As an example of this the case of Gen. McPherson may be cited. When Gen. Hood relieved Gen. Johnston in the command of the Confederate Army before Atlanta, he made a sudden violent attack upon Gen. Sherman's left. Just before the attack, Gen. McPherson, who commanded the Army of the Tennessee, was feeling anxious about the position of the enemy, and he rode to the furthest line of pickets to get information. Following the advanced line toward the left, he was at the extreme front when Gen. Hood's onset was made and he was killed in the first ten minutes of the action. Deprived of the commanding general, the Fifteenth Corps was routed and swept back upon the Seventeenth, and for a time there was every reason to fear that the whole position would be carried, involving a serious defeat to Gen. Sherman and possibly changing the whole subsequent course of the campaign. Had the telephone been in use from the front line to Gen. McPherson's headquarters, the latter's life would not have been lost.

The important requisites of a telephone for army use are that it shall be simple, not easily deranged, and able to stand rough usage. There is no reason to doubt that these essentials can readily be obtained, and then the constant use of the telephone in all army operations will be assured.

WHAT WE BUY AND SELL ABROAD.

The official statement of United States exports and imports, in which the returns from all the custom houses are corrected to August 23, gives the total exports of domestic merchandise at \$823,946,353, for the year ending June 30, while the merchandise imports for the same time were \$667,954,746, showing, as compared with the previous year, an increase in exports amounting to \$125,605,563, and increased imports of \$222,176,971. Of the imports, \$459,652,883 were of dutiable goods, and \$208,301,863 were free of duty. In the latter class the framers of our tariff intended, in a general way, to include many articles not produced at all here, as well as raw materials used in manufactures, making goods which were largely the product of foreign cheap labor pay a high rate of duty, in order to encourage our manufacturing industries. A large proportion of the value of the imports free of duty is covered in the two items of coffee and tea, which we received last year to the value

of \$80,143,390, as compared with similar receipts amounting to \$61,934,437 for the year preceding. Of chemicals, drugs, dyes, and medicines, about half our imports are free and half dutiable, the latter amounting last year to \$5,764,698, and the former to \$6,738,862, the free goods showing an increase of 50 and the dutiable of 25 per cent, as compared with the imports of the year preceding. But the most remarkable showing in the increased imports of free goods is found in the item of hides and skins, other than furs. These constitute a raw material, the bringing of which here from abroad to be manufactured involves the use of a large amount of capital and the employment of a great number of hands, whether the manufacture be only so far carried out as to produce leather, or whether, as with the greater proportion, it is carried forward into the making of boots and shoes. In 1878-9 we had a full average import, amounting to \$15,959,017, but for 1879-80 our receipts were far greater than ever before in the history of the country, footing up \$30,002,254. In the other articles free of duty which enter most largely into our manufactures, we find that the imports of India-rubber and gutta percha have increased from \$6,063,088 to \$9,606,239, rags for paper-makers from \$2,402,457 to 5,474,737, raw silk from \$8,371,025 to \$12,024,699, and block, bar, or pig tin from \$2,312,297 to \$6,223,176. The large capital and increased employment of labor necessitated by this larger use of raw material requiring so much work to fit it for the requirements of the public will at once be evident.

When we come to the imports of dutiable goods, however, such as are generally brought here in competition with the productions of our own manufactures, we find in most branches an increase quite as great as that noticed in our imports of free raw materials, a fact which would tend to discredit our general industrial prosperity were it not that we have such cumulative evidence to the contrary, and can see that these increased imports, bought from the superabundant proceeds of two bountiful crops, are but supplementing demands upon our own manufacturers which the latter find themselves unable to fill. Thus, in cotton manufactures, although the mills at Fall River, Lowell, and other places, have been producing more goods than ever before, our imports for 1879-80 were \$29,929,366, as against \$19,928,310 for the year preceding. So, too, in manufactures of wool, although our imports have increased from \$24,355,801 in 1878-9, to \$33,911,093 in 1879-80, the home industries in this line have been remarkably prosperous. In iron and steel and their manufactures the business has not been so steadily prosperous as in some other branches, because of the intense speculative fever which dominated that market during a great portion of the year, but there was a great improvement in the many industries embraced in this line as compared with the condition of the trade for the year preceding. It is to be particularly noted also, in this connection, that while our increased imports of this class were enormous, by far the largest items were of pig and old and scrap iron, which, considering the work necessary to turn them into marketable products as finished goods, may properly be considered as raw material. In fact these two items alone constitute more than half our imports of iron and steel and its manufactures for the past year, figuring for \$27,956,144, as against \$2,054,885 in 1878-9, while all our other imports in this class, such as castings, steel and iron rails, machinery, cutlery, files, saws, and tools, foot up to but \$26,757,844 in 1879-80, as against \$7,392,363 in 1878-9.

When we turn to the other side of the account, however, and look at the items which make up our increased exports, it is not at all surprising to find that in the shipment of manufactured goods we have only just about held our own, and that our larger shipments are almost entirely in grain, cotton, and provisions. Of the latter we had an unprecedented abundance, and the marketing thereof furnished the people with the abundant means which has enabled them to purchase so freely of manufactures. On this account the ambition to build up a trade in our manufactured goods in foreign markets has been, this year, to a great extent, held in abeyance, in the presence of an active and generally more remunerative home trade. Of course this has been only a temporary condition, to be probably followed by more earnest efforts than have ever before been made to enlarge the sale of our manufactures abroad, for, aside from the fact that we can hardly expect a continuance of such magnificent harvests, the great enlargement of our manufacturing facilities during the past year will compel those interested in such lines to seek wider markets, if they would place their trade on a permanently prosperous footing. There never has been a time more propitious than the present for the putting forth of the most zealous efforts in this direction. Labor is comparatively cheap, but at the same time all the necessities of life are sold at such reasonable rates that the condition of the workman is much better than in former years, when we had a vitiated currency and wages were much higher; American manufacturers, too, have now won such a position in most of the markets of the world that they will not have to encounter the prejudices which were formerly a chief obstacle in developing foreign trade, but they will find customers everywhere not only willing but desirous to meet them on grounds which cannot fail to be mutually advantageous.

HORSE RAILWAYS IN EUROPE.—Ten years ago the horse railway, or "tramway," was scarcely known in Europe. Now there are fully 700 miles of "tramways" in Germany, Great Britain, France, and Belgium.

BLIGHT OF PEAR TREES.

BY T. J. BURRILL, PROFESSOR OF BOTANY AND HORTICULTURE, ILLINOIS INDUSTRIAL UNIVERSITY, URBANA, ILL.

The writer has been very fully convinced by many observations and varied investigations, that this dreaded disease of the pear tree is caused by a minute organism belonging to a group of the lowest fungi, best known as *Bacteria*. These organisms require high powers of the microscope to detect their presence, hence the failure by microscopists to find anything to which the disease could be attributed. Much larger parasites, animal and vegetable, have been sought for, but sought for to no purpose, except to thoroughly establish the fact that insects and the ordinary parasitic fungi on plants were not the cause of the disease. Bacteria have not been known as active agents in the destruction of living plants, and microscopical investigations have not usually been of the peculiar kind to reveal them. But these organisms do occur, and may always be found in the bark of pear trees actually undergoing the change which we call blight. They multiply with rapidity and become excessively numerous, thousands in a minute drop placed under our microscope. They move to and fro with a slow, undulating, twisting, tumbling motion. They gradually elongate, becoming two or three times as long as wide, and then divide transversely into two equal parts, the joints clinging together for some time, but eventually separating entirely. The fluid which contains them may become dry and the life processes of the minute things apparently stopped for an indefinite length of time, when, by the addition of water, they recommence their movements and otherwise exhibit the phenomena of life.

Upon careful examination of the tissues of infected trees, we find that the stored starch grains gradually disappear. The protoplasm may not be destroyed, and the walls of the cells are left in most cases without the slightest trace of perforation or other injury. The disease is pre-eminently one of the bark. The wood, except in the case of very young shoots, is not affected. The water from the roots, passing as it does through the wood, may, and often does, ascend for months to living leaves above, while the bark is dead entirely around the stem or branch for several inches or even feet. The upper portion of course ultimately dies, unless as may happen when the cambium is not destroyed, a new bark is formed underneath the dead one. The leaves are invaded by the destroyer, but the sudden destruction often witnessed is especially due to the girdling effects upon the limb or trunk.

The progress of the disease in the tissues of the plant is always slow. The bacteria are not carried by the circulation in the fluids of the tree, but gradually work their way by their own powers of movement through the imperforated walls of the cells. These walls must present an almost unsurmountable barrier to their progress from cell to cell. Indeed, the puzzle really is how they get through at all. In old wood the cell walls become pierced with minute pores, but no such thing exists in the cells containing the stored materials upon which the bacteria live. The walls of such cells, though permeable by water, have no openings which the highest powers of the microscope reveal, either before or after the change produced by blight. The thick cells of the liber (*bast*) or inner fibrous layer are really proof against the invasion by the bacteria. Not unfrequently a continuous layer of these cells separates the diseased parts from those perfectly healthy. It may be that the progress of the malady is thus checked in some plants, while in others, with less bast, its course is uninterrupted.

In the fermentation which occurs of the starch, and presumably of other carbonaceous materials, carbonic acid, butyric acid, and hydrogen are formed. This is very different from the results of putrefaction or ordinary decay, and especially indicates the agency of bacteria, for the butyric fermentation is only known as a consequence of their action.

Having now indicated the changes which take place in the still living but infected cells, and having found an organism capable of producing these changes, it remains to show that this organism really does *cause* the phenomena observed. The proof is direct and it is believed conclusive. It consists in artificially introducing the bacteria into the healthy bark of living trees and noting the results. If in a great number of cases the disease follows such inoculation, plainly spreading from the minute puncture required, and if we are reasonably certain no other active agent is thus introduced, can the conclusion be avoided that the bacteria which we see multiplying and spreading from cell to cell, do certainly cause the observed changes, and thus the disease? This has been done in the most careful manner, and, in case of the pear tree, has been followed by disease in sixty-three per cent of the inoculations!

In a few of the operations small pieces of diseased bark were inserted as in budding, but in most cases the inoculations were performed by dipping a needle or sharp pointed knife into the fluid (distilled water) containing many bacteria taken from diseased trees, and thrusting the wetted instrument into healthy bark. As a counter check a *clean* needle or knife was frequently inserted in a similar manner in the bark.

In a row of fifty-five pear trees, three years old, certain evidence of blight followed in sixty-three per cent of the inoculations with bacteria, in no case from the puncture with a clean instrument, and in one case only spontaneously, *i. e.*, without conscious introduction by myself. Many ap-

plications of bacteria to the uninjured surface of the bark and the leaves were without result.

Inoculations in a similar way with virus from the diseased pear in apple and quince produced disease identical in every respect with that in the pear. Of those in the apple, thirty per cent only were successful, while one hundred per cent of the inoculations in quince clearly communicated the disease. In the apple the percentage successful was much reduced by the failure of all the inoculations in the bark of portions more than one year old. This may have been due to temporary causes, not to uniform conditions.

Here, then, is given the change in the tissues, a living thing known to produce such changes discovered, and its active agency confirmed by trial. Is it not more than probable that the bacteria really cause the disease?

The experiments above referred to (inoculations) were made during July and August, 1880, and papers based upon these and previous investigations were read by the author before the recent meeting of the American Society of Microscopists, at Detroit, and of the American Association for the Advancement of Science, at Boston. Examinations have since confirmed an expressed opinion that the disease of the peach tree, known as the "yellows," is also due to bacteria. The peach tree parasite, if such it may be called, is less in transverse diameter, being only 1 mm. (0.000343 inch) thick, and has shorter articulations. The length of what seems to be the typical form is 3.5 mm. (0.001202 inch). The physiological effects seem to be very nearly the same. The stored starch is destroyed and the cells left otherwise intact.

DESTRUCTION OF OYSTERS BY PETROLEUM.

The setting up of a large petroleum refinery on the shore of San Francisco Bay has been followed by the destruction of the shell fish along a wide reach of shore and the driving away of the shoals of food fish which formerly gave occupation and profit to many fishermen. The question has been before the California Academy of Sciences, and the evidence produced seems to be conclusive that the waste and refuse of the oil works floated upon the water and washed upon the shores are the sole cause of the heavy losses to the fishermen and markets of San Francisco.

A corresponding conflict of interest prevails in this region. The oil works at Hunter's Point have had the effect of spoiling a wide area of shore and river—East River, Hell Gate, and beyond—which once produced large quantities of fish, oysters, and clams. The oystermen and fishermen of Newark Bay and the adjacent waters complain that since the oil works have been established at Constable Hook the refuse oil from them has almost entirely driven the fish from those waters and has seriously injured the oyster crop. Just now they are complaining bitterly against the proposed extension of pipe lines in the waters of Newark Bay and the Hackensack River. The oyster trade of the bay is immense, it being one of the best of our northern fields for oyster seedlings. The fear is that the leakage from the pipes will injuriously affect if not entirely destroy this important industry. The fear is not without just foundation; but the petroleum industry is of such overwhelming magnitude and importance, and is operated by such heavy combinations of capital, that it is doubtful whether, even by an appeal to the State Legislature, the New Jersey fishermen will be able to arrest the evil which threatens them.

The Trans-Sahara Railway.

On his return to Marseilles recently, the chief of the Trans-Sahara Railway expedition, Colonel Flatters, reported the practicability of a route about 200 kilometers south of El Golea, in 24° north latitude. The expedition found a reasonable amount of water, never having been three days without it, and in the course of the exploration a lake was discovered full of fish and surrounded by vegetation. The general character of the soil was a hard sandstone, though for 80 kilometers there was an arid belt of very hard limestone. The whole country is much infested with snakes and lizards, and among the wild animals were antelopes in great numbers. The tamarisk tree grows luxuriantly in the Sahara, acquiring a development of three and a half yards in circumference. The price of salt is enormous, 100 kilos of this necessary article being valued at four slaves. As each slave is estimated at 900 francs, the cost of 2½ pounds of salt is about 28s. Colonel Flatters met with great friendliness on the part of the Tovaress, and he entertains no doubt as to the feasibility of the project.

Tin in Maine.

Referring to our recent article on tin mining in Maine a correspondent in that State writes that the promise of the mine at Winslow continues to be most encouraging, indeed far better than that offered by the best Cornwall mine at an equal depth from the surface. He adds that "with every day's work the seams are widening and rapidly converging towards what must at no great depth prove a champion vein of large dimensions."

Our correspondent is of the opinion, however, that the western portions of the State give indications of more valuable deposits of tin. In this region are extensive belts of gneissoid ledges interspersed with fluor spar, and in several places in Cumberland county fine specimens of cassiterite have been taken from what appear to be well defined seams. Some of these seams were laid open in rock cuttings for railways some years ago, but those who did the blasting knew nothing of mineral ores, and the geologists were looking for other things.

TOOTHED-WHEEL WIRE FENCE.

The engraving represents an improved wire for wire fences recently patented by Mr. Jacob Stoll, and being introduced by Messrs. Jacob Stoll & Co., of Fountain City, Wis. In this wire the usual rigid barb is replaced by a toothed wheel which is capable of revolving, thereby avoiding injury to cattle which may come into contact with it, while it affords a perfect barrier to the passage of either large or small animals.

The wire, as will be seen by reference to the engraving, is made with alternate twisted and looped sections, the latter being pressed inward at the middle to form bearings for the spur or toothed wheels and to receive the wires which bind the two sides of the loop together and also form the main support of the toothed wheels.

Fig. 1. shows a portion of the wire complete, and Fig. 2 shows the parts in detail.

This form of fence wire has a great advantage over those having fixed barbs, as the toothed wheels simply prick the animals without tearing their skin or flesh.

Further information in regard to this invention may be obtained by addressing Messrs. Jacob Stoll & Co., as above.

Another Sinking Railway.

An addition must be made to the list of railway submergences printed in this paper some months ago. One day last summer a strip of railway, eight rods in length, near Ravenna, Ohio, suddenly sank, leaving in its place a pond out of which flowed a stream "the size of a barrel," bearing large numbers of white shiners, sunfish, and rock bass. Gravel, to the amount of 4,000 loads, was thrown into the opening and a new bed made for the road; but the work was no sooner completed than it followed the original part into the same mysterious cavity.

NEW HAMMERLESS GUN.

Mr. William W. Greener, of St. Mary's Works, Birmingham, England, some few months ago turned his attention to breech-loading guns without hammers. The points primarily considered were the important ones of durability and simplicity, combined with safety and easy manipulation, and the engraving shows a gun in which Mr. Greener has successfully combined these essentials.

Fig. 1 is a longitudinal section of the gun, and Fig. 2 is a view from the under side, with the lock plate removed. The barrels are hinged to the breech frame in the usual manner; but instead of the ordinary gun lock without side hammers, the tumblers, A, are made nearly in the form of an elbow lever. These tumblers have their upper ends curved forward, and are provided with a small rounded point, which is arranged to strike through a small hole at the center of the breech piece instead of the ordinary firing pin. The lower front portions of the tumblers, A, are extended forward in the form of a flat arm, and these arms are curved laterally inward, so that their inner ends nearly meet at the center, as shown in Fig. 2, each arm terminating with a small rounded projection on its lower side. These tumblers, A, are located in a recess which also contains the mainspring.

To one of the projections in rear of the joint is pivoted a pendant, C, which plays loosely in a vertical slot in the center of the front arm of the breech frame, directly in front of the converging arms of the tumblers. This pendant has a hook-shaped projection which engages under the front ends of the arms of the tumblers, so that when the rear ends of the barrels are raised the hook raises the arms of the tumblers far enough to permit the dogs, B, to engage in a notch in the tumblers, thus automatically cocking the arm.

To hold the hook, C, back far enough to engage with the arms of the tumblers, a pin extends through a projection on the under side of the barrels. The usual style of triggers are arranged to operate upon the rear arms of the dogs for firing the arm.

Yale's Heliometer.

The heliometer in process of construction for the new observatory of Yale College will have a six inch aperture and eight foot focal distance. Though an inch less in aperture than the largest instruments in Europe, it is expected that this will be unsurpassed in working efficiency. The cost of the new instrument will be about \$10,000.

The Gabble of Science.

The tendency nowadays to bow down to science, and to measure everything by its scientific standing or importance, has a ridiculous side as well as a good one. The London *Times* comments as follows:

"The popularization of science has its drawbacks, and perhaps not the least of them is the sort of worship, analogous to that of very young ladies for the curate of the parish, which is offered by silly people to those who are—or, more frequently, who are supposed to be—the chief representatives of scientific learning. The absurdities of the so-called aestheticism are not peculiar to gentlemen who lunch upon the sight of a lily, but have their close analo-

such slight density that no moisture is felt even in the midst of a cloud. Waves of fog roll visibly by and fold one in their white embrace, but leave everything dry; dampness is a thing unknown. The hygrophant morning and evening records from 85° to 96° of moisture, a very large percentage; yet no dampness is felt on dress or skin. The springs are delightfully cool. The one nearest the hotel is only 13° above freezing. Ice is unneeded here.

NEW INVENTIONS.

An improvement in hand trucks, patented by Mr. William May, of Binghamton, N. Y., consists of a double hook hinged on the lower part of the truck frame, so that it may be thrown up or open to rest upon the toe or end cross bar of the device, and operate, in combination with a hook that slides on the central longitudinal bar of the truck, to take hold of and hold a barrel, cask, or large box, the double hook being so hinged that it can be turned or folded down for the purpose of adapting the hand truck for the conveyance of bags or other articles that might be injured by contact with them.

A toy bank, made in such a manner that coin cannot be shaken out through the inlet openings, has been patented by Mr. Edward L. Gobisch, of Jersey City Heights, N. J. The invention consists in combining with the top of a toy bank a flattened inlet tube having keepers attached to the lower ends of its edges, wires sliding in the keepers, and carrying a plate, so that when the bank is inverted the inner end of the inlet tube will be covered, and the escape of coin prevented.

An improvement in the class of heating stoves and grates in which cylindrical pipes are employed to form the inner side walls of the same, the pipes being open at the ends to allow air to enter and pass through them, and thereby become heated, has been patented by Mr. Ross Hall, of Millersburg, Ohio. The invention consists, first, in forming the inner wall or walls of the fire chamber or space of a stove or grate of pipes, having in cross section the form of a triangle (preferably an equilateral triangle), securing a greater heating surface than is practicable with pipes of cylindrical or oval form.

Mr. Enos P. Miles, of Clay Center, Kan., has patented improvements in the arrangement and operation of the evaporating pans and the furnace flues and dampers for regulating the direction and quantity of heating passing under them, the object of which is to supply to the pans a gradually decreasing heat suitable to the successive stages in converting the juice to sirup.

An improved balance slide valve has been patented by Mr. Edmund Haug, of Whistler, Ala. The object of this invention is to secure equal steam pressure upon the top and bottom of a steam engine valve as soon as expansion takes place in the cylinder.

Mr. Thomas B. Cook, of New Lancaster, Ind., has patented an apparatus for filling ditch scrapers, so constructed that the scrapers can be filled more rapidly and with less labor than when the ordinary apparatus is used. The invention consists in a lever anchored at one end by a double clevis, two chains, and two stakes, and provided with a hook and chain to receive the scraper. A shoe or wheel supports the free end of the lever.

An apparatus for raising and lowering the sashes and covers of forcing boxes, cold frames, and similar uses, so constructed that a number of sashes and covers can be raised at the same time and by the same operation, has been patented by Mr. Lewis G. Stocking, Burlington, Iowa.

A combined ash sifter and bucket, so constructed that the ashes may be sifted in a room without raising a dust, has been patented by Mr. Charles C. Burnett, of Iowa City, Iowa, and which, at the same time, will be convenient in use, strong, and durable.

The invention consists in a combined ash sifter and bucket formed of the bucket made with an offset and slots in its upper part, and having a pivoted bail, the sieve having a supporting flange and a handle, and the sliding guard plate to prevent fine ashes from escaping.

Mr. Charles H. Shaw, of Troy, N. Y., has patented a durable and effective clasp that can be attached to the bracelet without soldering.

Mr. John A. Harrington, of Groesbeck, Texas, has patented a simple device for preventing the tire from becoming loose because of the shrinking of the felly, and for preventing the loosening and rattling of the spokes.

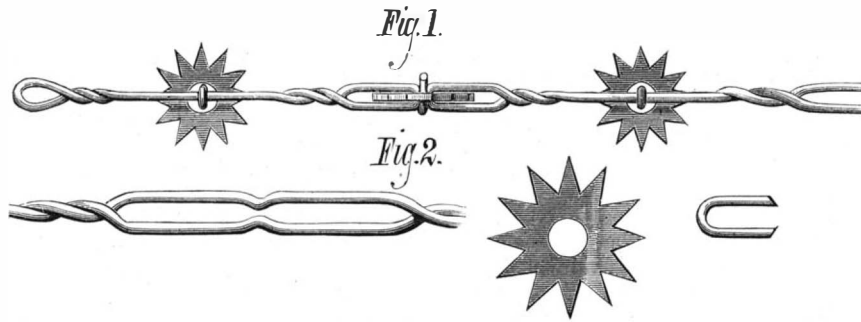
**TOOTHED-WHEEL WIRE FENCE.**

gies among those who profess to be scientific. There is a scientific jargon as well as an art jargon, both of them, in the lips of most people, concealing, or it may be even exposing, the most profound ignorance of the respective subjects of discourse. And there is a widely spread want of knowledge that the writer who has most successfully popularized a given question is not of necessity the one who is best acquainted with its depths."

The Mountains of North Carolina.

A correspondent of the *Tribune*, who went to the mountains of Tennessee and North Carolina "to avoid the heats of a Northern summer," writes as follows from the summit of Roan Mountain, 6,367 feet above the sea:

The prospect is magnificent; the grandest scenery in the United States east of the Yosemite. Over 100 mountain tops, not one of them less than 4,000 feet in height, are in full sight. This uplift in the heart of the Alleghanies, the Unaka range to the north, the Blue Ridge to the south, is declared by Prof. Gray, of Harvard, to be "the most beautiful mountain east of the Rockies." The flora on its sides changes with its increasing altitude. Chestnuts, sycamores, and maples clothe the base of the mountains, yellow birches and magnificent wild cherries line its sides, and beeches, alders, fir balsams, and immense groups of rhododendrons crown all but the very crest. On the top are 1,500 acres of the richest mould; the winds sweep the crest too fiercely for trees. Here botanists love to come to study mountain flora. Pro-

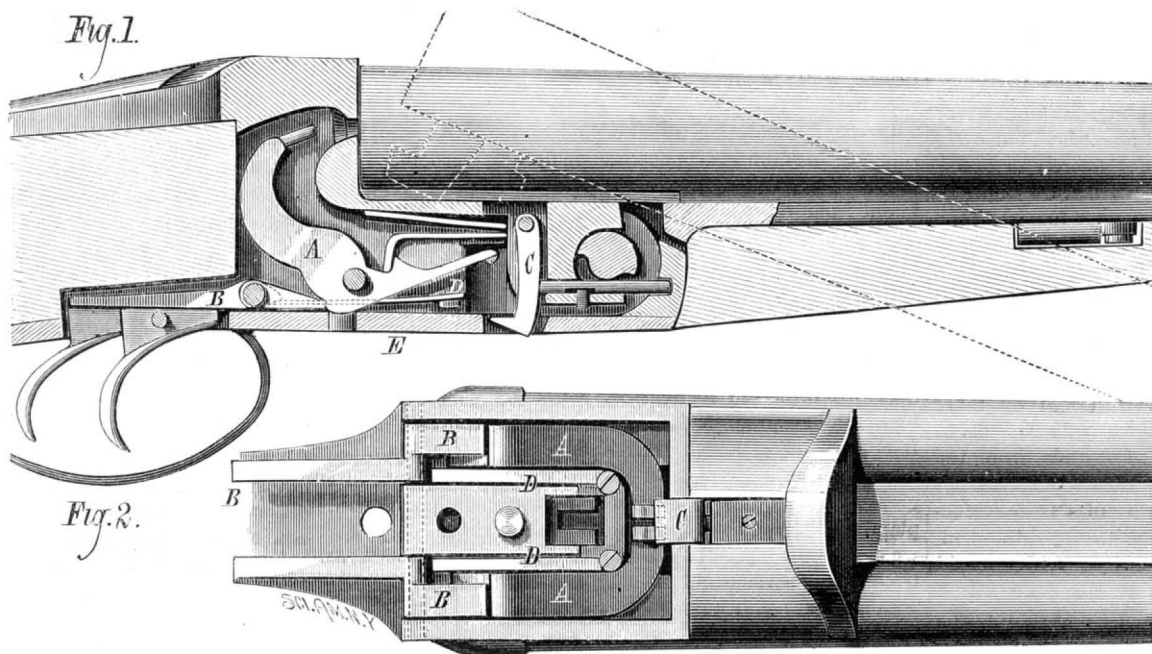
**GREENER'S HAMMERLESS GUN.**

fessors Gibbs and Goodale, of Harvard, have left us, but seven other scientists remain to seek health and to study science. Here they find mountain heather, superb groups of rhododendrons, azaleas, and other shrubs and grasses that can be found nowhere else in America. They will not grow at lower altitudes or on the same height in other places.

The fauna of these mountains is that of much colder regions. Little snow birds abound. They find the temperature their nature craves a thousand miles this side of Canada. An occasional eagle, numerous buzzards, and many robins fly around. Great clouds of fog fill the valleys, and at times sweep the mountain top. But the atmosphere is of

Method and Apparatus for Destroying Fire Damp.

When fire damp or carbureted hydrogen has accumulated in large quantities in a mine it has been the custom heretofore to vacate the mine and fire the gas. This process is ordinarily attended with great danger, and it has been found that the gas, when lighted, will, in most cases where the gas is heavy, first burn slowly, and as the flame increases in volume the gas will become highly heated from contact therewith, and, being driven into a confined space, will be caused to explode with great violence, and will destroy the timbering of the mine and choke up its passages with *débris*, which will render them inoperative and oftentimes result in the loss of life. Robert Blackledge, of Enfield, Conn., seeks to overcome this danger by the employment of a great number of separate flash torches or rockets, that are to be distributed over the mine in various places, wherever the gas may be accumulated, and that may be lighted at such points simultaneously or in quick succession, so that the gas will be lighted at a new point before the flame from the first point lighted shall have reached the second point. By this means the gas may be ignited at the farthest point from the pit's mouth first, and carry the gas flame, after damp, and smoke forward toward the mouth of the pit or the nearest draught outlet, where the greater part of the poisonous gases of combustion and the gases remaining unconsumed will escape with the draught harmlessly. The method and apparatus for accomplishing this was patented September 21, 1880.

NEW CHIMNEY CAP AND VENTILATOR.

We give an engraving of a novel and simple chimney cap recently patented by Mr. William D. Bartlett, of Amesbury,

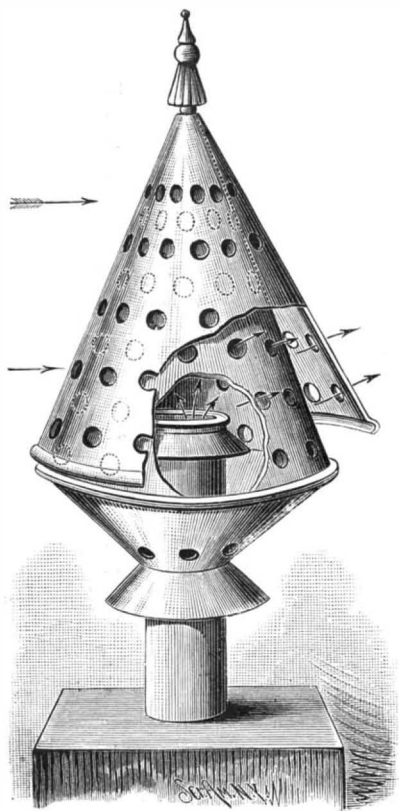

BARTLETT'S CHIMNEY CAP AND VENTILATOR.

Mass. It is designed to meet all the conditions necessary to the perfect working of a chimney or ventilator, and works equally well in a high wind or perfect calm. In this respect it is claimed that this device has great advantages over others intended for the same purpose, and in its construction it is certainly as simple as could be desired.

The chimney cap consists of a perforated cone closed at the bottom and forming a housing around the escape flue, which cap is fitted with a perforated conical hood that is slightly larger than the fixed cap, and is hung loosely at its apex, so that it may swing freely. The holes in the hood do not register with those in the fixed cap, so that as the hood is pressed by the wind against the cap the openings are closed on the windward side, while there is free exit at the opposite side.

The cones are broken away in the engraving to show the internal construction.

This device is adapted equally well to chimneys and to ventilating shafts or flues.

The Comet in Pegasus.

The comet discovered by Lewis Swift in the constellation of Pegasus is as large as any nebula north of the equator, except the nebula in the triangles and the great nebula in Andromeda. It can be seen in moonlight, but is not a bright object. It may be the comet of 1812, but this is a mere surmise. The condensation and nucleus are eccentric, evidently indicating the presence of a tail greatly foreshortened. The comet is so nearly in opposition that the tail is about on a line joining the earth and sun. Its slow motion indicates that it is either approaching the earth or receding in almost a direct line. If approaching it may be come an object of great interest. Its apparent size indicates that it is either quite near the earth or else enormously large.

Paper Making Industries in China.

The Commissioner of Customs at Wuhu (China), in a report recently issued, states that paper is very extensively manufactured in the numerous little villages situated in the valleys among the hills, about eight miles to the southeast of the city of King-hien. It is made from the bark called T'an-shu-p'i, the paper-mulberry tree bark, and wheat straw, which, after having been well washed and boiled with a certain proportion of lime, is again washed, and then exposed to dry for a whole year on the sides of the hills, in spots where the grass and brushwood have been previously cleared away for this purpose. After the year's exposure, it is washed once more, and then pounded on a stone with a large wooden hammer; it is supposed to require 1,400 blows from this hammer to reduce it to the necessary consistency; after which it is removed to another building, and left to soak until it becomes quite a pulp, in a large earthenware vessel, containing a liquid glue, made from boiling the branch of a tree called the Yangkowt'eng, a species of hooked vine. This pulp is then put into a cistern of water, and well stirred up with a stout stick. A finely made bamboo frame, or sort of long oblong sieve, is taken by two men, one at either end, and dipped twice into this liquid, which is made to run equally over the whole surface, somewhat after the manner in which the photographer allows the developing solution to run over his plate. By this means, a thin and tolerably even layer is left, which soon partially dries and forms the sheet of paper, and which is removed by simply reversing the frame. As soon as a sufficient number of sheets has been made, they are taken to the drying room. This room contains a large brick oven, coated on the outside with lime, and built up to within a few feet of the roof. Upon the top of this oven the paper is placed, in parcels of about a foot in thickness, until perfectly dry; after which sheet by sheet is damped once more, and while still moist, is by means of a soft brush made to adhere to the sides of the oven for a short time, to undergo its final process of drying. It is then taken away to the packing room, and made up into bales, weighing from 80 to 120 catty each, the catty being equivalent to 1 1/4 lb. avoirdupois. The largest sized paper is about one "chang" (11 3/4 feet) long, and is worth one dollar a sheet. This particular size of paper is made entirely from the "T'an-shu-p'i," but the smaller sizes are composed of a mixture of the above-mentioned bark, or the bark of the paper-mulberry tree, and wheat straw. This paper is known by the name "Suan-chih," and is considered a good quality paper in the Chinese markets.

The Grotto Under Mount Rossi, Sicily.

The eruption of Mount Etna in 1669, says *La Nature*, was the most formidable of historic times. The side of the mountain opened for a length of about four miles, and there issued from it a torrent of lava four miles broad, which, after destroying several villages and half of the city of Catane, flowed into the sea and formed a promontory two miles long by half a mile wide and sixty feet high. At the same time the scoria and sand thrown out by the craters formed a mountain with a double crest, that was at first called Monti della Rovina, and later Monti Rossi, on account of the reddish color that the scoria on the two crests assumed through the oxidation of the iron contained in it. The higher of the two crests is about 800 feet above Etna, and about 3,000 feet above the sea. In the interior of the cone of Mount Rossi there are two immense extinct craters, exhibiting the characteristic funnel-shape, and the sides of which are formed of scoria in a decomposing state. Up to 1823 no one had had the curiosity to descend to the bottom of these craters; but at this period the intelligent observer, Mario Gemellaro, undertook their exploration. He saw with some surprise a horizontal aperture at the bottom of one of the cavities, and entering it with a torch, he found, after traversing a suite of corridors resembling the galleries of a mine, a large well, into which he caused himself to be lowered by means of ropes. At some feet from the bottom of this well he found a vast rectangular room, at the further end of which there was a passage which grew smaller and smaller, and at last became impassable. This remarkable grotto, which was named Grotto della Palombe, is situated exactly in the center of Monti Rossi. It has now been opened to travelers, the descent being facilitated by a stairway, and the cavern being illuminated by magnesium light instead of the former resinous torches.

Concussons as the Cause of the Oil Fires.

To the Editor of the Scientific American:

Having noticed in your columns the troubles of the oil regions, I thought I would make a few experiments with a view to learn the true reason of the tanks being fired. I find that under certain conditions a mixture of oil vapor and water vapor can be fired by concussion. I would suggest as a remedy a floating cover to each tank. The amount of oil lost by evaporation would pay the cost of such cover, and it would always act as an extinguisher. Heavy thunder is the probable cause of the fires. D. F. STAFFORD.

Skipanon, Clatsop Co., Oregon, October, 1880.

TWINKLING OF THE STARS.—This is generally conceded to be due to moisture in the upper air. M. Montigny, in a paper published in *Les Mondes*, holds that very pronounced twinkling of the stars indicates either commotion in the upper regions of the atmosphere or a sudden fall of temperature there, thus denoting the conditions of an early appearance of bad weather.

Rare Elephants.

There are now on exhibition in this city two peculiar elephants brought from the mountains of the Malay peninsula, about 800 miles from Singapore. They are remarkable for their small size, being respectively 28 and 36 inches tall; and for being covered with a thick coat of bristly hair or wool. They are supposed to be from five to seven years old. In size they resemble the extinct elephants of Malta, and in covering, those of Siberia. Their woolly coat is attributed to the circumstance that they live high upon the mountains where the climate is cold. The species appears to be all but unknown to naturalists, this pair being the first that have survived the passage through the heated low country to the coast and the subsequent journey by sea. The sailors on the steamer which brought them—the Oxfordshire, Captain C. P. Jones—named them Prince and Sidney. They are described as playful and harmless, and they keep their little trunks stretched out to strangers to be petted. They love to be scratched on the under side of the trunk close to the mouth, and they hold their trunks curled back over their heads as long as any one scratches them. Like elephants of larger growth, they keep up a swaying motion, either sidewise or forward and backward. When a visitor lets one of the little fellows take his hand he delicately curls his proboscis around it and carries it gently to his mouth. Then he trumpets his satisfaction.

IMPROVED NURSERY CHAIR.

The engraving shows a light and convenient nursery chair recently patented by Mr. J. C. Klett, 260 West 37th street, New York city. When in use it appears as in Fig. 1, but it is readily folded into the compact form shown in Fig. 2.

Fig. 1

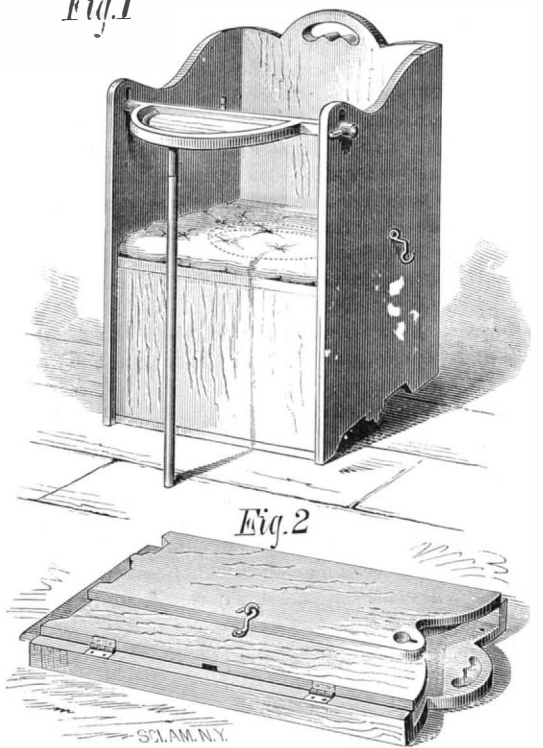

KLETT'S NURSERY CHAIR.

The chair is composed of a back, two hinged sides, and a hinged seat, all of which are provided with hooks or catches for retaining them in position while the chair is open for use. The chair is also provided with a pivoted shelf which serves as a stay for the sides and is readily separated from the other parts for packing. This chair is very convenient for regular every day use in the nursery, and is a necessity for persons traveling with children. It folds so compactly and is so light that it may be readily carried in the trunk.

Further information may be obtained by addressing the inventor as above.

Lowell Mills Burned.

Two important Lowell mills, the Chase and the Faulkner, were destroyed by fire October 6. The former was of brick, 225 feet long by 60 wide and 68 feet high, five stories on the front elevation and six in the rear, with a one story L, used as a boiler house. The mill contained 12 sets of cards, 6,600 spindles, 60 broad looms, 40 of them newly equipped last year. It was built in 1863, and gave employment to 300 hands.

The Faulkner mill was of brick, 91 by 54 feet, five stories high, and a three story L, 25 by 54 feet. It had 8 sets of cards, 2,720 spindles, and 44 looms, employing 100 hands. The annual production of the two mills was 750,000 yards of fancy cassimeres and cloakings, consuming 600,000 pounds of wool.

Preserving Rubber Instruments.

Various articles and instruments made of rubber are apt, with time, to become dry, to crack, grow brittle, and lose their elasticity. Dr. Pol recommends the following simple mixture: Water of ammonia, one part; water, two parts; in which the articles should be immersed for a length of time, varying from a few minutes to one-half or one hour, until they resume their former elasticity, smoothness, and softness.

Astronomical Notes.

OBSERVATORY OF VASSAR COLLEGE.

The computations in the following notes are by students of Vassar College. Although merely approximate, they are sufficiently accurate to enable the observer to recognize the planets. M. M.

POSITIONS OF PLANETS FOR NOVEMBER, 1880.**Mercury.**

Mercury will probably be seen after sunset early in November. The planet will be 9° south of the sun in declination, and will set about an hour after the sun on the 1st. The best time for seeing Mercury will be on the 3d or 4th. The crescent moon will pass east of Mercury on the morning of the 4th.

Mercury will approach the sun, and will scarcely be seen after the 15th.

Venus.

On November 1 Venus sets at 6h. 14m. P.M. On November 30 Venus sets at 6h. 46m. P.M.

It will be brilliant in the southwest all through November, setting farther and farther south until the 21st. The crescent moon will pass eastward of Venus on the 4th.

Mars.

Mars is not likely to be noticed in November.

On the 1st of the month it rises at 6h. 26m. A.M., and sets at 4h. 45m. P.M.

On the 30th Mars rises at 6h. 16m. A.M., nearly an hour before sunrise, and may perhaps be seen preceding the sun and about 2° north of the sun in declination.

Jupiter.

Although Jupiter has passed its best position, ordinary observers will scarcely perceive its diminished brilliancy.

On November 1 Jupiter rises at 3h. 47m. P.M., and souths before 10 P.M., at an altitude of 51° in this latitude.

The moon passes north and east of Jupiter on the 13th.

On the 30th Jupiter rises at 1h. 48m. P.M., and passes meridian before 8 P.M.

Making our observing hours between 8 and 10 P.M., we find from the "American Nautical Almanac" that the two satellites nearest to Jupiter (the 1st and 2d) may be seen to pass from the face of Jupiter nearly together on November 1, so that Jupiter will be seen at first with two moons only; on November 8 the same two may be seen to enter upon the planet's face again nearly together.

On November 9 the first satellite may be seen to come out from the shadow of Jupiter; on the 16th and 23d this satellite will go behind Jupiter.

On November 24, while the first is in transit, the second will disappear by going behind Jupiter, so that Jupiter may be seen with only two moons.

On November 10 the largest satellite will be seen to move slowly away from Jupiter, and the smallest moon will come out from the shadow. On the 17th the largest satellite may be seen to move toward Jupiter, while the smallest is again hidden in eclipse.

On November 28 the third will enter the shadow of Jupiter early in the evening and remain more than two hours, when it will come out and slowly regain its brightness.

Saturn.

Saturn follows Jupiter, coming to the meridian 50 minutes later, all through the month of November, and reaching an altitude about 4° higher than Jupiter.

On the 1st Saturn rises at 4h. 27m. P.M. On the 30th at 2h. 24m. P.M.

The moon passes east of Saturn on November 14.

Saturn appears small and pale beside the glowing color of Jupiter, but it even surpasses Jupiter in interest. Of its eight satellites, very few can be seen with ordinary telescopes. Titan, the largest, was west of the planet on October 7, and nearly at its greatest distance. As this moon goes around Saturn in a little less than 16 days, it will be seen again far west of the planet on October 23, and far east of Saturn on the last day of October. Its revolutions around can be counted in this way.

Japetus can probably be readily seen in its orbit path far from Saturn, and requiring about 80 days for a revolution.

A telescope which will show Rhea, the next smallest satellite, will afford a great source of interest, as Rhea goes around the primary in 4½ days, and its motion can be seen in one evening.

The ephemeris of these satellites, published by Mr. Mentz in the "Astronomische Nachrichten," gives Rhea as in conjunction with the center of Saturn, and below the base of the planet, on November 12, a little after midnight, Washington time.

A good telescope of three inches aperture will enable an observer to see Rhea at that time.

Uranus.

Uranus rises on November 1 at 1h. 46m., and on the 30th at 11h. 52m. P.M.

Its diurnal path is almost wholly between midnight and noon.

Neptune.

Neptune is in excellent position early in the month, on the meridian near midnight, at an altitude of 62°. On November 30 Neptune crosses the meridian circle at 10 P.M.

The Electrical Spur.

As a supplement to the electrical bit, noticed by us some time ago, it may now be stated that Mr. G. Hüttmann, imperial equerry at Vienna, employs the electrical current in a very ingenious manner in order to facilitate the management of the horse, especially for ladies.

To the left side of the saddle a small box which contains a galvanic battery and an induction coil is fastened. From this apparatus two silk coated wires are conducted to a special girth-leather, which end into two blunt metallic brushes touching the flank of the horse at that place where usually the spur is applied. These wires are also connected with the riding whip, which has two ivory knobs. By a pressure of the finger upon one of these knobs the current is closed and conducted to the wire brushes, where it acts as a spur in a strong and sudden manner, while when the other knob is touched a weak and continued current is originated, acting like the pressure of the thigh of the rider.

The electricity may not only be used by ladies, but will also prove useful to the equestrian performer in the circus in order to manage several horses at the same time, and to the groom in order to prevent horses from crib-champing and other bad habits. In Paris electricity is also used for preventing carriage horses from running away, a battery being connected with the bit of the horse.

THE FAN-TAILED POODLE

The *Deutsches Familienblatt*, of Berlin, gives the above, which it styles "A new American invention—dedicated to the Society for Preventing Cruelty to Animals."

Hot Ice.

In his experimental investigations of the boiling points of substances under low pressures, Mr. Thomas Carnelley has been able to maintain water in the solid state at temperatures far above the boiling point of water. The conditions under which it is possible thus to heat ice he describes as follows:

"1. In order to convert a gas into a liquid the temperature must be below a certain point (termed by Andrews the critical temperature of the substance), otherwise no amount of pressure is capable of liquefying the gas. 2. In order to convert a solid into a liquid the pressure must be above a certain point, which I propose to call the critical pressure, otherwise no amount of heat will melt the substance. If the second of the above conditions be true, it follows that if the necessary temperature be attained, the liquefaction of the substance depends solely on the superincumbent pressure, so that if by any means we can keep the pressure on the substance below its critical pressure no amount of heat will liquefy it, for in this case the solid substance passes directly into the state of gas, or, in other words, it sublimates without previous melting."

By maintaining a pressure below 4.6 millimeters of mercury—that is, the tension of aqueous vapor at the freezing point of water—Mr. Carnelley was able to keep water frozen in a vessel so hot that it would burn the hand. Other substances also exhibit these same phenomena, the most notable of which is mercuric chloride, for which latter the pressure need only be reduced to about 4.20 mm. On increasing the pressure the substance at once liquefies.

Shooting Oil Wells with Nitro-glycerine.

A few years ago nitro-glycerine was only used in the oil wells in the very small quantities of one or two quarts at a time. Within a short period it has become a very important agent in bringing petroleum to the surface. When exploded in the oil wells over the oil-bearing rock it opens wide seams, through which the oil flows with great force and freedom, thus saving much labor and expenditure of capital. There is now used in every well that is drilled from thirty to two hundred pounds, which is worth eighty cents a pound to the producer. It costs about thirty cents to manufacture, and nets fifty cents on every pound to the manufacturer. Thousands of pounds are consumed every month, and there is a growing demand for it.

A correspondent of the *Sun*, who had assisted at the reopening of one oil well by the explosion of 100 pounds of nitro-glycerine at its bottom, gives the following description of the operation: A cartridge case or shell of tin, 15 feet long, was lowered into the casing of the well by means of a wire rope, and then filled with water. The glycerine was then poured into the shell, and, being heavier than water, forced the latter to flow out. When all the glycerine had been poured in the shell was lowered 1,800 feet into the well, and there rested on what is called an "anchor," 25 feet from the bottom. It was now ready to be set off. There was about 700 feet of oil above the shell. Through the center of the shell ran a small tin tube, inside of which was a small iron rod in four pieces. On the end of each piece was placed a common percussion cap. At the top of this rod was a tin plate so arranged that anything dropped down through the

casing would strike it, and the force of the falling article would set off the caps, which would in turn explode the nitro-glycerine. The charge was exploded by dropping a small piece of iron tubing into the well. At the moment of discharge "the earth trembled violently, then came a dull sound, and a second later there rose into the bright moonlight, 100 feet high, a solid stream of oil, which fell on everything near, and continued to fall for three minutes. This stream of oil was one foot in diameter when it began to flow, but it soon settled down to a stream of about 1½ inches, which is a natural flow."

AGRICULTURAL INVENTIONS.

A sulky plow, patented by Mr. Thomas T. Harrison, of Aubrey, Kansas, is an improvement on the sulky plows for which Letters Patent No. 218,734 were issued to the same inventor August 19, 1879. The improvement simplifies the construction and renders the plow more easily controlled.

A fruit gatherer, for gathering oranges and other fruit without bruising or injuring the fruit or trees, has been patented by Mr. Levi J. Knight, of Manatee, Fla.

Mr. Lewis Y. Lenhart, of Red Wing, Minn., has patented a seed planter, so constructed that it may be operated from the drive wheel or by hand power, as the character of the ground may require.

Messrs. William V. Morgan and Thomas W. Hackman, of Allerton, Iowa, have patented an improved sulky plow so constructed that the plows may be easily attached to and detached from the carriage, and may be readily adjusted and controlled.

Mr. John H. McPherson, of Xenia, Ohio, has patented a tooth for grain drills, so constructed that it can be readily detached for sharpening and for convenience in passing from place to place, and which will swing back should it strike an obstruction.

Thread from Wood.

The manufacture of thread from wood for crochet and sewing purposes has, it is said, recently been started at the Aby Cotton Mill, near the town of Norrköping, in the middle of Sweden. The manufacture has arrived at such a state of perfection that it can produce, at a much lower price, thread of as fine quality as "Clark's," and has from this circumstance been called thread "à la Clark." It is wound in balls by machinery, either by hand or steam, which, with the labeling, takes one minute twelve seconds, and the balls are packed up in cardboard boxes, generally ten in a box. Plenty of orders from all parts of Sweden have come in, but as the works are not yet in proper order there has hardly been time to complete them all. The production gives fair promise of success, and it is expected to be very important for home consumption.

The Public Domain.

The annual report of Commissioner Williamson, of the General Land Office, shows that there were surveyed during the fiscal year ending June 30, 1880, 15,699,253 acres of public lands and 652,151 acres of private land claims. This is an increase in the amount of public lands surveyed of 725,347 acres over that of the last year. This great increase is attributed to the operation of the act of March 3, 1879, which led to a great increase in the number of applications by private individuals for public surveys. Disposals of public lands during the year were made as follows:

	Acres.
Cash entries	850,740
Homestead entries	6,045,570
Timber culture entries	2,193,184
Agricultural college scrip	1,280
Locations with military bounty land warrants	88,522
Swamp lands patented to States	3,757,888
Lands certified for railroad purposes	1,157,375

The area of public lands surveyed in the different States and Territories during the last year is as follows:

	Acres.	Acres.	
Arizona	308,521	Nebraska	709,179
California	3,792,630	Nevada	938,694
Colorado	2,775,601	New Mexico	1,624,156
Dakota	2,130,808	Oregon	1,052,221
Idaho	225,637	Utah	440,585
Louisiana	80,504	Washington Territory	847,595
Minnesota	296,253	Wyoming	184,449
Montana	302,413		

In addition to this, surveys were made of private land claims in three States and Territories, as follows: California, 58,708 acres; Arizona, 149,258 acres; New Mexico, 444,184 acres. The total area of public lands surveyed from the beginning of surveying operations up to the close of the last year is shown to be 752,557,195 acres, leaving an estimated area yet unsurveyed of 1,062,231,727 acres.

THE Chester Steel Castings Company have just completed another addition of 60x90 feet to their works at Chester. The superiority of their steel castings for many purposes is becoming better known by locomotive and steam engine builders and machinists generally, and their orders have increased largely. They claim that their castings finish up smoother, admit of a finer polish, and will resist a greater amount of wear and tear than iron forgings, and require less labor in finishing, as a casting can be made nearer finished size than a forging.

An Elevated Railway for Costa Rica.

The government of Costa Rica has entered into a contract with J. Mosen-Chiarin for the construction of an elevated railroad from San José, the capital, to Rio Sucio, there to connect with the railroad in course of construction from Limon. The work is to begin within six months from August 9, and to be ready for traffic within ten months from the same date.

On the Production of Ice and Cold by the Binary Absorption System of C. Tessié du Motay and Aug. I. Rossi. Patented Feb. 3 and June 8, 1880.

In the different systems so far used for the production of ice and cold (excepting the air machine and the Carré machine), recourse has been had to the volatilization of a liquid by relieving the pressure exerted by its vapors on itself by means of a vacuum pump, driven by a steam engine, a mechanical compression, aided by the cooling produced by a circulation of water in a condenser, being invariably the means employed to effect the liquefaction of the vapors, so as to render the cycle of operation continuous. A difficulty has been encountered at the start.

With most of the liquids to which preference has been given the tensions of their vapors, at the temperatures of ordinary running water, reach very high figures. These pressures follow a physical law, keeping an absolute and mathematical relation with the temperatures. In most temperate climates, during the warm season, running waters, or such as are supplied from hydrants in cities, are at a temperature not below 75° Fah., and even more. In these conditions liquid ammonia has a tension of 150 to 160 lb. per square inch; chloride of methyl, 80 lb.; methylic ether, 78 lb.; sulphurous dioxide, 60 lb. In tropical climates, and under many latitudes in the United States where waters are above 85° and 90° Fah., the above figures are higher yet. These may be found the causes of many unsuccessful attempts made to introduce industrially the manufacture of ice.

These pressures render difficult the keeping of joints tight. Hence leaks follow, causing a loss of material and consequent failing in production; in short, the successful operation of these machines is interfered with. The machines have to be carefully constructed, at a great cost, and require for some of these liquids very elaborate and complicated mechanism.

Large quantities of water are necessary for the condensation of the vapors, otherwise the outflowing water will reach temperatures much above 75° Fah., and as a consequence the resulting pressures will be much above the figures above quoted. This question of condensing water plays a very important part in the introduction of ice machines for specific purposes. In certain industries, such as in breweries, where this water is scarce or has to be paid for, it has been found to be a cause of exclusion of many machines. Certain of the liquids employed besides have special chemical properties, which render their use attended with other causes of trouble; among other properties, their action upon metals when in presence of water.

In the "Practical American," vol. 1, No. 5, New York, May, 1880, it is stated that the destruction of a large anhydrous sulphurous oxide machine (system of Mr. R. Pictet, of Geneva), which was in operation in St. Louis during the meeting of the American Association for the Advancement of Science, in 1878, was caused by an accident of this kind; a small pin hole in a casting having given access to more moisture, the sulphurous dioxide employed was transformed into sulphuric acid, causing the moist spot to become more and more corroded, until at last, in one night, all the gas escaped through this hole, and thus was lost the whole charge of the machine, some 4,200 lb., and the condenser destroyed.

About a year ago Messrs. C. M. Tessié du Motay and Auguste I. Rossi, in experimenting on the ethers, have found that, in general, the ethers formed by the acids, as well as their alcoholic radicals, possess the property of absorbing sulphurous dioxide, some of them to the extent of 300 times their volume of gas in certain conditions, ordinary ether standing foremost. They have based on this property a new system for the artificial production of ice and cold, which they have called the "binary absorption system," a graphical description of which has been given in this paper (February 21, 1880).

In this system the liquid employed is the ethyl-sulphurous dioxide obtained from ordinary ether by saturating the latter with sulphurous gas. This liquid, at a temperature of 60° to 65° Fah., has no pressure and can be kept readily in glass bottles at 80° to 90° Fah.; it has only a few pounds tension—2 to 5 pounds. Thus a machine charged with it, when stopped, will actually show no pressure on the gauges, and even a vacuum at rest, if the temperature is low; while with the other liquids mentioned above, even the stoppage of the machine does not prevent the pressure of the vapors inside to soon reach its point of equilibrium with the temperature outside, and even at as low temperature as 32° Fah., sulphurous dioxide alone, as used in the Pictet machine, has still 15 pounds per square inch of pressure; exerting thus a constant and increasing pressure on the vessels containing it, and in case of a small leak starting causing the entire loss of the charge. What is said here of sulphurous dioxide applies with still more force to the liquid ammonia, methyl chloride, methylic ether, all liquids of which the vapors have higher tensions yet than sulphurous dioxide at the same temperatures.

Now, if such a binary liquid is evaporated under a vacuum it is resolved into its two constituents, the mixed vapors entering the pump together, then under a small compression ether liquefies first, a few pounds pressure being sufficient for it, even with waters such as are met in tropical climates. The ether thus liquefied absorbs in the condenser the vapors of sulphurous dioxide, reconstituting the "binary liquid," and thereby avoiding the excess of mechanical compression which would have been otherwise necessary to effect this

liquefaction of the dioxide. Thus to the work of compression of the pump is substituted a power of chemical affinity and absorption of the less volatile absorbent for the vapors of the most volatile. Thus, to the advantages of low pressure of ether are combined the advantages of intensity of cold produced by the volatilization of the sulphurous dioxide, avoiding its drawbacks. In presence of water and of the ether the sulphurous dioxide is transformed, not into "sulphuric acid," as before, but into "sulphuric acid," the action of which acid upon metals is insignificant if not absolutely null. The sulphurous acid being an extingisher relieves the ether of one of the drawbacks of its use, and acting as self-lubricant renders the greasing of the working parts unnecessary.

In a machine on exhibition at Messrs. C. H. Delamater & Co.'s, foot of 14th street, N. R., which has been running several months, making 6 tons of ice daily, the pressures in the condenser in normal and regular running have been of 14 to 15 pounds, reaching as low as 10 and 11 pounds in best conditions, and not higher than 20 to 23 pounds in the most unfavorable conditions of water, etc.

The water used for condensation has been $\frac{1}{4}$ to $\frac{1}{2}$ that used and necessary for a Pictet machine of same production, the pressures being $\frac{1}{2}$ to $\frac{1}{3}$.

In these conditions of pressure the machine has worked easily and without wearing, the gauges stopping at 0 when machine was stopped, thus rendering leaks impossible at rest, and reducing them to a practical minimum when running. After several weeks of running, day and night, the machine was examined and the different parts working were found in perfect order, showing that there has not been any corrosive action of the liquid upon metals.

Owing to the small pressures, these machines are much simpler in their details of construction; all complicated valves, cocks, or other mechanical contrivances required for others can be dispensed with, three ordinary globe valves, such as are used for steam, being all that is necessary. Their attendance is easy, as it can be ascertained from parties who have them in use in breweries.

The machine working at C. H. Delamater & Co. since April, has been making 6 tons daily of solid, merchantable ice, which was readily disposed of in the market as fast as made, at prices leaving a large margin for profits. This machine, which is still in full operation, is open to the examination of the public.

The New York Ice Machine Co. (Room 54, Coal and Iron Exchange Building), which has bought the rights to the patents of Messrs. C. Tessié du Motay and Aug. I. Rossi for the United States, have one of these machines working successfully at Ph. Schaefer's Brewery, 59th street and 10th avenue, where it gives entire satisfaction. The proprietors consider it a "simple, practical, easily attended machine," doing all it was guaranteed to do. It cools the cellars of said brewery, keeping them at 40° Fah.

Several other machines are either in course of construction or being put up at other breweries or for making ice in and outside of this city.

Another machine which is completed now and will be ready to work at Hotel Vendome, in Boston, Mass., as soon as this hotel will be opened to the public, will have to cool provision rooms, wine rooms, cellars, making besides half a ton of ice for consumption and 200 carafes daily.

Hose Pipe Nozzles.

Who is going to invent the nozzle of the future? There is no nozzle that we have ever seen that seems to us to control the stream it delivers as it should do. Instead of projecting a solid stream for a long distance, the water breaks soon after leaving the nozzle, and soon sprays and breaks up altogether. We often hear of steamers throwing 250 and 300 feet, but we recently heard a veteran chief say that he had yet to see the apparatus of any kind that would throw a solid stream 100 feet. The difficulty may be all with the water, which is naturally inclined to separate, but we are of the opinion that part of the trouble lies in the construction of the nozzle. An experiment made at Boston by putting a core into a play pipe, and thus dividing the stream into four parts, depriving it of its rotary motion, showed a gain of thirty feet in distance playing. But even this does not seem sufficient. Our steamers give us power enough for throwing, and the hose in use gives every facility for carrying a large volume of water; there should be some means devised for delivering that volume in a solid stream at long distances. Great difficulty has been found in making nozzles operate uniformly at all times. A manufacturer of steamers once found a nozzle that gave him great satisfaction; with it his steamers could throw greater distances than with any he had ever tried before. He ordered half a dozen just like it. The half a dozen were made precisely like the first, but never equaled it in delivering water. There is much to be learned yet regarding this question of delivering water on fires, and the exact relations existing between pressure, hose, play pipes, nozzles, and the friction of water more clearly understood.—*Fireman's Journal.*

Dried Potatoes in California.

A California inventor has made a machine for pressing and drying potatoes so that they will keep for years, yet preserve their natural flavor. No chemicals are used in the operation of curing, everything being done by a simple machine capable of pressing six hundred bushels of potatoes in twenty-four hours. The machine not only presses the potatoes, but lays them on a tray in a concave form with

the hollow side down. After the pressure they are put into a drying apparatus, where they remain for two hours, then they are ground into coarse meal resembling cracked rice.

The first shipment of these preserved potatoes to Liverpool, last year, brought a large profit. The average price of potatoes in San Francisco is about twenty-five cents a bushel. Dried, they brought in England forty-five shillings a hundredweight, or at the rate of a dollar and a half a bushel for green potatoes. This year preparation has been made for drying and shipping large quantities. It is said that there are three hundred thousand acres of uncultivated land on the western slope of the Coast Range, near San Francisco, especially adapted to potato growing. The fogs and mists from the ocean supply sufficient moisture, and the soil yields bountifully. The only problem heretofore has been where to market the product.

MECHANICAL INVENTIONS.

Mr. August P. J. Bossel, of Virginia City, Nev., has patented an improvement in bench planes which consists, first, in a novel construction, arrangement, and combination, with the plane bit, of a toothed plate or rack, and a pinion for adjusting the bit, and a wedge for holding it when adjusted; and also in a novel arrangement of the handle of the plane and devices connected therewith for adjusting said handle at different positions.

An improved baling press has been patented by Mr. John Grizzel, of Augusta, Ark. The object of this invention is to furnish presses for baling cotton and other materials, so constructed as to compress the material very quickly, and which can be conveniently and easily operated. The invention cannot be readily described without engravings.

Mr. George W. McArthur, of Laingsburg, Mich., has patented a machine for cutting hoops from poles, which is so constructed as to adjust the knife automatically to the bends of the pole and cut the hoops of uniform thickness.

An elevated scale beam for head blocks has been patented by Mr. John A. Reynolds, of Danville, Penn. The object of this invention is to provide the head block of a saw-mill with an elevated scale beam that may be at all times plainly visible, and upon which may be boldly marked the scale measurements, so that the mill operative may at a glance ascertain the thickness of the log upon the head block and readily adjust the log relatively to the saw in order to cut from it any required thickness of material.

The Blanket Brigade.

While in Boston attending the great celebration, Chief Leshure had a fine opportunity of seeing the working of the blanket brigade of that city, as applied to a fire in an elegant Park-street club house. The furniture, which was of the most costly description, was gathered together in the center of each room and covered with the carpets as they were stripped from the floor, and then the mammoth rubber blankets were spread over the whole, before the streams from six different hose pipes were let on the burning roof. The whole building was of course deluged, so that the water ran down the stairways in rivulets, but owing to the protection of the blankets, the percentage of loss on the furniture was comparatively small. Mr. Leshure came back more enthusiastic than ever concerning the organization of a Springfield blanket brigade.—*Springfield Republican.*

Ocean Temperatures in the Pacific and Atlantic.

Herr von Boguslawski has been led, from a comparison of the results of recent deep sea investigations, to the following conclusions respecting the temperatures of the Atlantic and Pacific oceans: 1. The water of the North Pacific is, in its whole mass, colder than that of the North Atlantic. 2. The water of the South Pacific is, down to 1,300 meters (4,225 feet), somewhat warmer than that of the Atlantic, but below the depth colder. 3. The bottom temperatures are generally lower in the Pacific than the Atlantic at the same depths and in the same degree of latitude; but nowhere in the Pacific are found such low bottom temperatures as in the Antarctic portion of the South Atlantic, between 36° and 38° south and 48° and 33° west longitude, in which bottom temperatures of -0.3° C. to -0.6° C. have been measured. 4. In the western parts of the Pacific, and the adjoining parts of the East Indian Archipelago, the temperature of the water reaches its minimum at depths between 550 and 2,750 meters (1,787 and 8,937 feet) remaining the same from this depth to the bottom. In the whole of the Atlantic the temperature from 2,750 meters (8,937 feet) to the bottom gradually though very slowly decreases.

A REMARKABLE instance of lightning ascending vertically is reported to the French Academy of Sciences as having occurred last month at Paris. M. Trecul relates that during a violent storm just at nightfall of the 19th ult., he saw flashes rising vertically, and apparently starting from the tips of lightning rods, though he is not sure that they started from them. The flashes went out in a kind of luminous ball, diminishing in the intensity of the light from the center toward the circumference. One of the smallest of these had an oval shape of from 8 to 10 inches in width, terminating the column of fire. On two occasions two of these luminous columns, having risen at a distance apart about equal to the space between two lightning rods, suddenly darted toward each other at right angles to their vertical course and went out on uniting, making no flash and no noise.

APPARATUS FOR DETERMINING THE ELECTRIC CHARGES OF FALLING RAIN.

When it was demonstrated by Benjamin Franklin that thunder clouds were masses of watery vapor charged with electricity, the conclusion was very natural that the rain falling from such clouds might possess the same charge, and the electricians of a former generation contrived apparatus to prove this and to estimate the amount of the charge. In consequence of the advance of electrical science and the multiplicity of various pieces of novel apparatus, the old contrivances are now nearly forgotten, but our attention has been called to this subject by the recent suggestion that the ignition of petroleum tanks, now so alarmingly frequent, may sometimes be caused by rain from a thunder cloud.

It may, therefore, be well to give to the readers of the SCIENTIFIC AMERICAN an engraving of one of these pieces of apparatus as it was in use nearly a century ago by investigators of atmospheric electricity. It consists of a globe, *g*, of brass wire attached to a conducting wire, *h h*, which passes through a long glass tube, *k l*, supported by an insulating stand, *c*, placed on the window sill, *b*, and a few cords, *d*, attached to the upper sash, *e*, the lower sash, *a*, being raised. The end of the wire is provided with a brass ball, *m*, reaching over a table, *t*, on which a gold leaf electrometer, or any other equivalent apparatus, may be placed, which, being brought into contact with, or even in the vicinity of the charged globe, *m*, will indicate the electric charge of the rain.

Experiments with this apparatus have shown that the drops of occasional showers are most always more or less charged with electricity, and that it is only totally absent during foggy, moist days and rain storms of long duration; that on the contrary, sudden rainfalls after a clear spell are always charged, and that, as was expected, the strongest charges are obtained during thunder storms. Even traces of electricity have been occasionally observed without any rain falling, the air itself being charged.

DAVEY'S SIMPLEX MOTOR.

We give engravings of a form of motor for small powers, invented by Mr. Henry Davey (and called by him the "Simplex"), which is being constructed by his firm, Messrs. Hathorn, Davey & Co., of Leeds. This little engine is exceedingly simple and direct in its construction, and it is probable that it may take a not unimportant place among the small power motors in the improvement of which so much has been done of late years. Mr. Davey's machine is in reality a steam engine, in so far that it works almost entirely by steam, but as a steam engine it has the special feature that it has no boiler, in the sense at least of any vessel containing a considerable quantity of water. A reference to the engravings will show that it has a single cylinder only, made with a very large piston rod so that the area above the piston is much greater than that below. The space above the piston is, in fact, the real working cylinder, while the space below is only a compressing pump. The steam distribution is effected by a slide valve shown in Fig. 2, while the pump chamber has connected to it two small single-beat valves, one (Fig. 1) opening inwards, and the other (Fig. 2) opening outwards into a coil which lies within the furnace, this coil taking the place of the boiler. It is inclosed in a cast iron casing lined with fire-brick, and the fire is placed below it, as shown. The way in which the engine works is as follows: On its up-stroke the piston draws a quantity of air into the cylinder below the piston, and along with this air a small quantity of water is always taken in. This last comes about by the help of the little cup above the suction valve, into which a fine stream of water is constantly running. On moving downwards the mixture of air and water is first compressed up to a point determined by the working pressure of the engine, and then pushed through the delivery valve into the coil, when the little puff of water is

at once flashed into steam. There is no valve between the delivery valve of the pump and the slide valve, but perfectly free communication, and each time a new portion of water is introduced into the coil, a corresponding portion of steam passes away to the steam cylinder. Here it works exactly in the usual way, about which nothing more need be said. It will be seen that the engine may be briefly described as a steam engine which has no boiler, but takes in its feed water as it requires it instead of working always from a large reservoir of steam and water. The air does not appear to play any appreciable part in driving the piston; its chief use is to insure that the water, when sent into the coil, is really blown in as spray, and not allowed to drop or run in.

One of the first of these motors (having a cylinder 3.5 inches

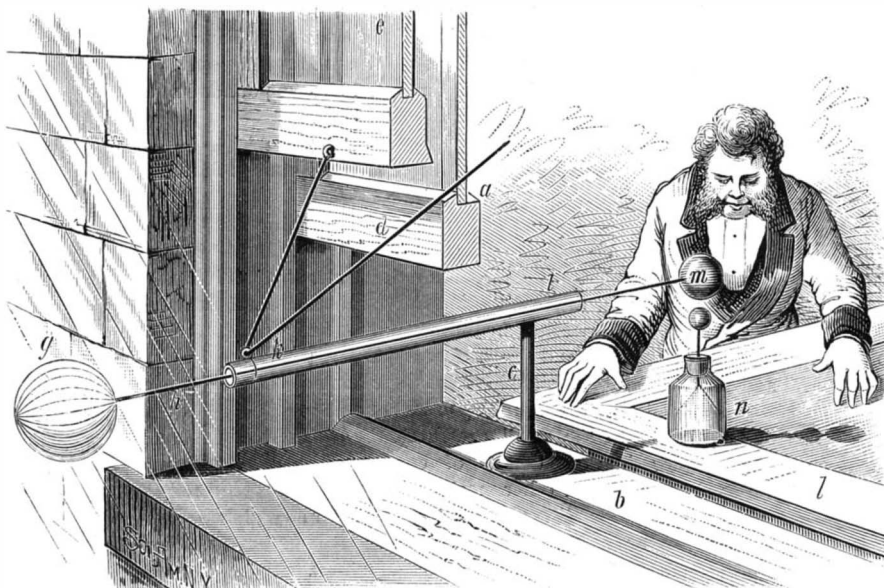

APPARATUS FOR DETERMINING THE ELECTRIC CHARGES OF FALLING RAIN.

in diameter, and 4 inch stroke) has been for some time at the Engineering Laboratory of University College, where the students have made a number of experiments with it, working under various conditions. The motor has been very considerably improved since this particular one was made. In his later engines Mr. Davey has used a small separate pump set on the top of the cylinder, instead of employing the space under the piston for a pump, and in the larger sizes he is making the cylinder double-acting.

This little motor is very substantially made, it takes up very little space, is easily started, and has no explosible boiler, and we do not see why it should not be made very

economical of steam, although this has not been attempted in the first instance. There is plenty of room in the world for all the small engines that have yet been brought out, and we shall be glad to hear that Mr. Davey has been successful in getting his well into use.—*Engineering.*

Color Blindness in Dyeing.

While the attention of scientific experts is being called to this subject, in reference to railroad employes and all persons concerned in the distinguishing of colored lights and signals, as connected with the necessary precaution in the protection of human life in traveling, it might not be deemed an undesirable opportunity for us to call the attention of our special community to the immediate bearing which this defectiveness of vision has on operative dyers. It will readily be granted that no artisan has more necessity for extreme nicety of ocular discernment in shades of color than the one whose whole occupation is among them; and that on the critical truthfulness of his vision depends the accurate production and reproduction of tints, which to fail in would cost serious sums to his employer.

Color blindness, in the full meaning of the term, is not likely to exist among dyers, but it is not only likely, but very possible to produce at least some of the effects by the changing of colors; that is to say, the workman who has his eyes engaged constantly on a red, for instance, if put on to a green may find himself in trouble, and so on through various colors. Now, as to tint shades, is it not very evident that the impression received on the eye by looking on one tint continually will incapacitate the sight for the perception of a true and exact shade of that color?—and yet extreme accuracy is demanded. Let a dyer working on a red for some time have his attention turned to a blue, and will he not at first see a purple?

Most certainly, because the visual rays are fraught with red, and when brought to bear upon the blue, blend with it, at first strongly, and gradually thereafter.

All have not been gifted alike; it is evident that with some workmen this affection may be still more injurious than with others. Those of bilious temperament are subject to a yellowish influence on the vision, which must of necessity prove fatal to the truth of observation in color.

There is no sense more exquisitely delicate than that of sight, and there is no man more dependent on its ability than the dyer.

In taking up the trade of dyeing the early learner knows nothing of the nature of his sight, but goes at it as though it were plowing, or any other calling in which the sensitiveness of the eye is not called into requisition at all. But how important is the constitution of the eye to him who is engaged in a study of colors which must be carried to the most minute perfection. Now, how necessary is it that an examination by a qualified expert should decide on the healthy state of the eye before the trade is chosen. And still further, how advisable is it that occasional examination should be made by a doctor of the eyes of every workman in the dye-house, to decide whether there is any decrease of visionary power, and to prescribe the fitting treatment if there is.

Every employer should consider this matter, and see if his interest is not concerned in it; for the health of the sight of a good, faithful man is as much their concern as the bodily health is his.

While on this subject we may as well suggest the very simple practice to testers of colors of having a purely white material as a plain on which to rest the sight when alternately viewing colors; by this means the eye is enabled to take in the succeeding tint without any influence from the former one.—*Textile Colorist.*

Invaded by Slugs.

Four or five years ago a Rochester gentleman received from Germany a box of bulbs in which he found a number of large slugs. They were unwisely set free in one of the city parks

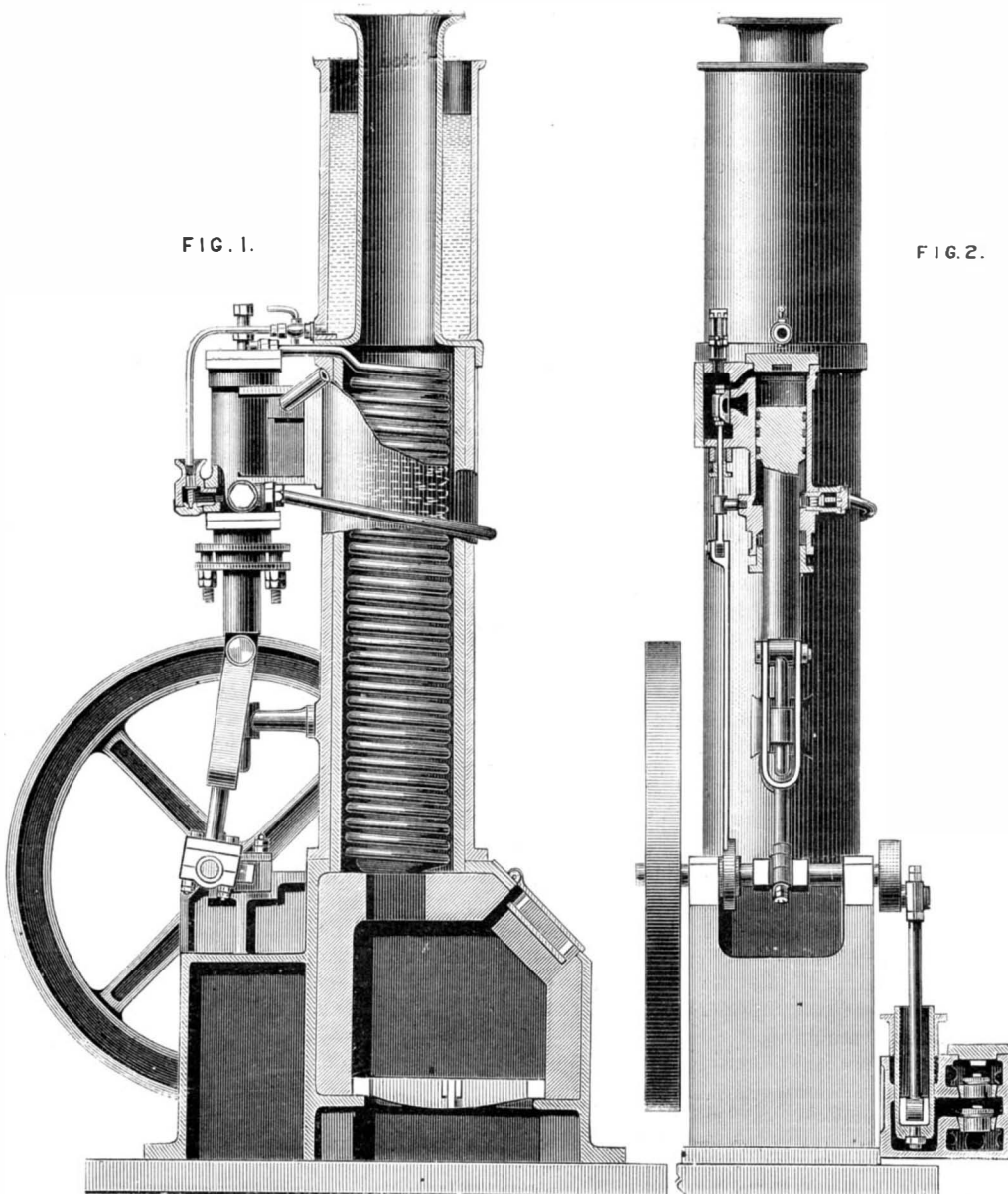

DAVEY'S SIMPLEX MOTOR.

where they seemed to have thrived to an alarming degree, spreading over the city in a way to make them a serious nuisance. They are much larger than any native slugs, measuring from four to six inches in length, and are likely to become very injurious to vegetation.

NOTE ON TURPENTINE, ROSIN, AND ALLIED PRODUCTS.*

Of the turpentine collected in this district very little is shipped North. Most all of it is distilled upon the water courses near the pine forests. The small quantities of crude turpentine now sent North are used in making printer's ink.

Turpentine is distilled in copper stills now. Formerly iron stills were used. Then the resulting oil was red. When the first copper still was used in Wilmington the clear uncolored oil shipped North was rejected, because it was not considered genuine "spirits."†

All crude turpentine is distilled with water. The part which water plays in the process will be seen hereafter.

The present distinction as to the grades of rosin are somewhat different from *yellow* and *transparent*.

It is not the presence of water which makes rosin *yellow*. If water gets into rosin, which it does sometimes by accident, the rosin becomes opaque. All the better grades of rosin are yellow or amber color, more correctly; but the term "yellow rosin" is not used here commercially or otherwise. The grade of the rosin depends, *first*, upon the quality of the turpentine, and *second*, upon the skill in distilling. "Virgin turpentine," the first exudation from a newly chipped tree, if skillfully distilled, will yield "window-glass rosin," of which there are two or three grades. If by any means water gets into prime rosin it becomes opaque. This accidental addition of water must take place after the rosin has been drawn off from the still.

"Yellow dip" turpentine, which is the running of the second and subsequent years, yields the medium grades of rosin; while the "scrapings," the inspissated gum from the



COLLECTING TURPENTINE.

tree facings, yields an inferior rosin, from very dark to almost black. The black rosin is not due to burning in the still, as has been stated.

Anhydrous rosin is the greater part of the stock produced; the opaque rosins, being accidental, are limited.

The following description of the process of distillation may explain further.

A fifteen-barrel copper still (barrel weighing 220 lbs. each) is charged early in the morning. Heat is applied until the mass attains a uniform temperature of from 212° to 316° F. This is continued until the accidental water, that is, the water contained in the crude turpentine as it comes from the forest, has been driven off.

The first product distilled over is pyroligneous acid, formic acid, ether and methylic alcohol, with water. This is known as *low wine*.

All the accidental water having been distilled off, a small stream of cold water is now let in, so that the heat is kept at or below 316° F., the boiling point of oil of turpentine. The oil of turpentine and water now come over, and the mixture is caught in a wooden tub. This tub is constructed as follows:—

The distillate is caught at *A* from the still and separates into water and oil. At *B* there is an overflow spout, which discharges into the tub *D*. The water is kept low enough in the lower part of the tub to prevent its overflowing through the cock *B* into the receptacle *D*. From this receptacle it is put into oak casks, well made with iron hoops, and securely glued inside.

The distiller tests the quality of the flow from time to time in a proof glass. The distillation is continued until the proportion of fluid coming over is nine of water to one of oil of turpentine. At this stage the heat is withdrawn, the still-cap is taken off, and the hot rosin, which remains in a fluid state in the still, is drawn off by a valvular cock at the side of the still near the bottom

* By Thomas F. Wood, M.D., in *New Remedies*.
† The commercial name for oil of turpentine.

This rosin passes through a strainer before it reaches the vat, to rid it of foreign substances, such as straw, pine cones, chips, etc. From the vat it is bailed by wooden buckets, fixed on a long handle, into the barrels.

Rosin is graded by standard samples fixed upon by the "Produce Exchange."

The yield of oil of turpentine from "virgin dip" is about six gallons to barrel.

The yield of oil of turpentine from "yellow dip" is about four gallons to barrel.

The yield of oil of turpentine from "scraping" is about two gallons to barrel.

Other-products now attract our attention, viz., the distillation of *rosin oil*.

The rosin oil of commerce is produced in the following way: Rosin is introduced into an iron still, the lower grades being used for this purpose, and heat is applied until the temperature reaches from 316° to 320° F. Water and pyroligneous acid and naphtha come over first, and for some time, until the rosin is exhausted of naphtha. The heat is then raised to near the red heat of iron, when the rosin boils, and water and *oil of rosin* distill over together. This is crude rosin oil. It is a heavy, nearly opaque, whitish viscid fluid, opalescent on the surface.

This crude *rosin oil* is rectified by redistillation, and the resulting oil is transparent, dark-red by transmitted light, with a decidedly bluish cast by reflected light. It is deeply opalescent, more so than petroleum oil.

The residuum left in the still is a black mass with a shining fracture, giving the hues of crystal aniline.

Other products still remain to be spoken of, viz., *naphtha* and *oil of tar*.

Tar when distilled yields pyroligneous acid, water, *naphtha*, or spirits of tar, and *oil of tar*. The *naphtha*, when purified by a second distillation, is clear and of a very pleasant terebinthinate odor. The *oil of tar* comes over in the latter part of the process, and a black residuum remains in the still resembling pitch. All but the last-named of these articles have a commercial value.

Tar is distilled in iron retorts, just as rosin is. There are many complex bodies which have come to the attention

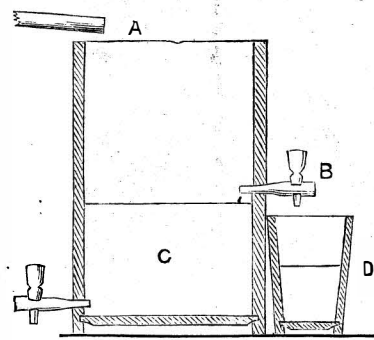

TUB FOR SEPARATION OF TURPENTINE FROM WATER.

of the manufacturers during their operations. Some of them have been very intelligently worked out and identified by Mr. William A. Martin, the chemist of the works we have visited. Some remain to be investigated. Terebinthine products have always been exceedingly interesting chemically, and just now we are moving toward practical commercial results. I am expecting to announce, at no distant day, that we have made a sure step in the right direction.

The English Channel Tunnel.

The works which are going on at Abbot Cliff Tunnel, between Folkestone and Dover, on the Southeastern Railway, in connection with the sinking of a shaft for testing the geological formations of the locality, with a view to the formation of a tunnel between England and France, were inspected July 20, and pronounced satisfactory by M. Léon Say and the French engineers, including M. Duval, M. Oretton, and the Count de Montebello. A shaft 90 feet deep has been sunk from the level of the engine house at high water, and a heading has been driven to the level of high water mark for the purpose of depositing the chalk. Powerful machinery has been fixed for the purpose of driving an atmospheric drill, with which it is intended to drive a heading as far as Dover, a distance of three miles, under the line of railway, the heading at Dover to be 300 feet deep. The experiments are being carried out under the direction of Colonel Beaumont and Captain English. The Southeastern Railway Company have made a grant of \$30,000 for the purpose.

Food Value of Root Crops.

Chemical analysis gives the following results with regard to the food values of different root crops:

Total Amount of Nitrogenous or Flesh-forming Material.	Pounds.
In 1,000 pounds of potatoes	20.08
In 1,000 pounds of mangolds	11.25
In 1,000 pounds of sugar beets	10.00
In 1,000 pounds of turnips	21.25
In 1,000 pounds of carrots	13.12
Total Amount of Carbonaceous or Fat-forming Material.	Pounds.
In 1,000 pounds of potatoes	237.4
In 1,000 pounds of mangolds	107.2
In 1,000 pounds of sugar beets	174.4
In 1,000 pounds of turnips	81.7
In 1,000 pounds of carrots	139.1

THE DOWD TUNNELING SYSTEM.

FIGURES 1 and 2, see next page, illustrate the Dowd tunneling system, in perfecting which the inventor, Mr. O. B. Dowd, of 122 East Nineteenth street, New York City, has been engaged for some years past. It furnishes means of excavating for and constructing tunnels in soft and treacherous ground, and under great pressure.

The system provides a shield absolutely safe for the workmen while passing through strata of hard and soft mud, quicksand, "land-springs," poisonous gases, etc., and capable of passing bowlders and making an entrance in rock.

It provides for excavating the immense amounts of silt, clay, etc., by steam power instead of manual labor to insure rapid progress, and it provides for the construction of a tunnel with water and gastight walls, having strength even under pressure of about four tons to the square foot to allow a margin of safety of 50 to 1, and to resist constant pounding of heavy trains on its inverted arch; at the same time it has the longitudinal rigidity of a tubular bridge, so that in parts passing through "land-springs" or exceptionally soft pieces of ground there is no danger of breaking out cross sections of the tunnel. (Special attention has been called to this difficulty by able engineers, and the trouble was *practically* illustrated by the breaking out of portions of the Cleveland tunnel, under Lake Erie, the sections retaining their cylindrical form and moving several feet from line of the remaining tunnel.)

A water and gas tight joint is formed in the rear of the shield, and in the front edge of the tunnel sections afford firm and reliable support for hydraulic jacks by which the shield is propelled and guided.

Figure 1 is a longitudinal sectional elevation of a portion of a tunnel, and the shield employed in its construction. A represents a cylindrical iron shield of great weight and strength, having internal diameter slightly greater than external diameter of tunnel, B. The shield is made watertight in front by an adjustable head (C), composed of strong



A TURPENTINE STILL.

iron sections, and has a large central opening in which is fastened by bolts, etc., the collar, D, which forms the bearing for shaft, E. This shaft carries the strong rotating steel tunneling arm, F, on each side of which are blunt edge cutting tools.

The arm is about one foot in front of shield head. G is a cog-wheel upon shaft, E, for revolving it, which is effected by two oscillating compressed air or steam engines, as shown in cut on opposite sides of the cog-wheel, G. (When steam is used the smoke-pipe is connected with the ventilating exhaust tube, to carry the smoke out of the tunnel.) Shaft E is hollow and has a tube within it extending to the junction with arm, F, and the arm has two longitudinal water passages indicated in cross-sectional view, Figure 2, by dotted lines; each is connected with the water passages shown on either side of arm, F. A tube in the shaft is arranged so that by a part revolution of it the connection can be made so as always to drive the water through the side of the arm which is moving forward.

The shield being in place, the shaft and arm are moved slowly, revolving in either direction, and small quantities of water are forced through the shaft and arm to dissolve the silt and clay as they are scraped from the heading by the cutters, and form a semi-fluid, about the consistency of thick cream, according to the amount of water forced in, so that the arm is found to move easily in this sort of disk of soft material. Between this and the head of shield another disk forms, about a foot thick, of much harder consistency, and in silt or clay remains adhering to the head of the shield. It is sometimes found desirable to force compressed air through the shaft and arm, and good results are obtained. The air disintegrates and drives the earth from the front of the arm, and forms minute bubbles, and gives greater elasticity to the silt, etc., allowing the arm to move freely.

It should be observed that no part of the disk in which the arm moves is a vacuum or air-filled space, as this can occur only in exceptionally firm silt or clay; on the contrary there is a constant pressure on all sides of the arm and on the head

of the shield—the pressure in difficult portions of the work being as great as four tons to the square foot.

The shield is pressed forward by hydraulic jacks, H, H. In excavating for a full-size railroad tunnel eight twelve-inch bore jacks should be used, of strength capable of bearing a test of about 3,000 tons combined moving power, but arranged to work advantageously for the comparatively small power usually required of them.

Bars, I I, connect by socket joint with the pistons of the jacks, and reach back to the front edge of the iron tunnel, on which they have a reliable support. The jacks force the shield forward; at the same time the shaft and arm revolve and cut and mix the silt with the injected water, and the semi-fluid silt is pressed backward through pipes, J J, and falls into the car, K.

This car should be of sufficient strength to carry the silt removed from a section of the heading about four feet long.

When the shield is advanced until its rear end reaches the front end of the tunnel section, the gates, L L, are closed, stopping the flow of silt, etc., the car is drawn to the mouth of the tunnel by a wire rope, and the load dumped through gates in the bottom of the car. The course of the shield may be changed by shutting the cocks in the pipes leading from the pumps to the jacks on that side toward which it is to be directed, and allowing the remaining jacks to advance the opposite side.

The tunnel itself is made of solid sections of cast iron pipe, entirely free from any longitudinal seams—this form being used for economy of construction and to give greater resistance to crushing force than the previously-made iron tunnels; for instance, the second Thames, the sections of which are made up of smaller pieces bolted together.

The desired form of R. R. tunnel is a slight oval about

Several of these sections being in place, and under pressure from the jacks, four steel or iron links, or bars, O O, are placed while hot upon lugs cast on the interior of the section, as shown, drawing them together by shrinkage while cooling.

These links may be used with say five hundred tons each, or about two thousand tons combined contracting power, and in very bad ground two more bars may be used in other lugs cast on the side of the tunnel sections, to insure very great longitudinal rigidity. The packing between the sections form a water-tight joint, and it will be seen the form of joint illustrated admits of repacking at any time from the interior of the tunnel, in case a slight leak occurs.

Among minor details of the system may be mentioned the use of the well-known sand ejector, but of peculiar form, consisting of a large portable tube with a smaller air tube within it extending to the end of the larger pipe.

This pipe when required is placed obliquely with its upper curved end over the dirt car, and its lower end projecting through the lower edge of the shield head, and flush with its outer face; a hose is attached to the small tube, and compressed air is driven through it, blowing the sand or earth backward and upward into the car.

This plan is found of value in certain kinds of sand for giving greater ease of motion to arm, F, but in silt or clay it is unnecessary.

The ejector is also valuable when placed from two to six feet lower down—that is, through an oblique opening at the lower front of the shield cylinder—to excavate for sinking below line of progress any boulder or similar obstruction which might prove too great for the unaided power of the arm to force downward. While using the ejector, and, indeed, at all times, except when in hard silt or clay, the shield should be pressed forward with considerably more

need not be used, as the tunnel would be of considerable thickness.

Cost of excavating in slit or clay and putting sections in position and placing tightening bars, it is believed, need not exceed seven dollars per lineal foot. It is believed that silt can be excavated at least fifty times faster by this process than with the well-known Brunel shield, in which the earth was removed principally with the bare hand.

Before any reasonably accurate estimate of the cost of the entire tunnels can be made, it is, of course, necessary to determine the grade and the consequent length of the tunnels required. The originator of the above system, after considerable investigation, is convinced that the *inclined plane system* is far the most desirable for passing trains through most short subaqueous tunnels. In this system a long inclined plane is prepared, down which the train runs by its weight. It is then raised over a shorter incline by means of an endless wire rope, which passes over a large wheel with a grooved face, and thence to the foot of the incline, and around a small pulley, and it is moved like a belt by the large wheel at the head of the incline. This rope is supported by a number of small sheaves.

The propelling power is a stationary engine, which revolves the large wheel. For making the connection of the train with the rope, a special kind of truck with clutching device is used.

It is coupled with the ordinary cars, and is called a "pusher" or "puller," as it is used in front or at the rear of the train.

The problem being, for instance, to move a train from Jersey City to New York, it is believed best to have the mouth of the tunnel near the New Jersey bank of the river, and by one long inclined plane to run nearly three-fourths across the river, and then by a shorter and steeper

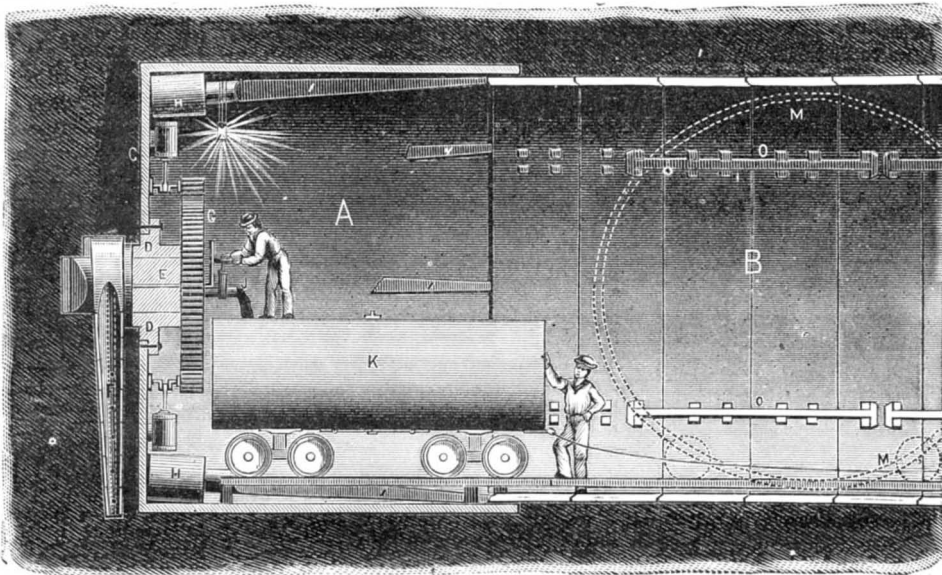

Fig. 1.

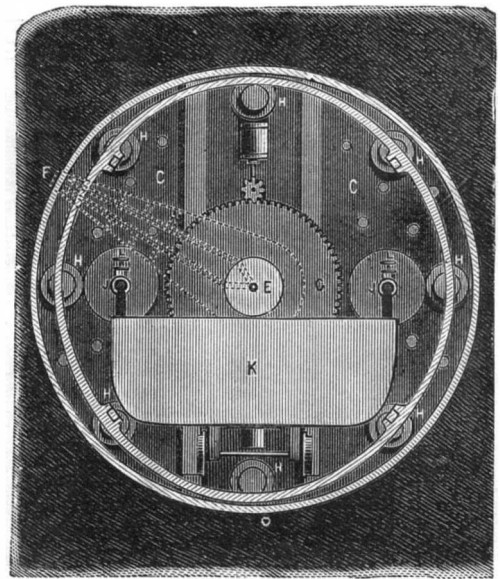

Fig. 2.

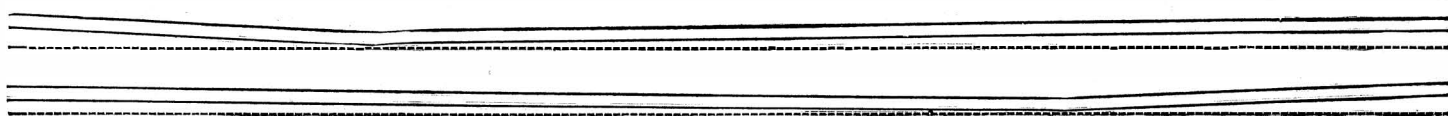

Fig. 3.

THE DOWD TUNNELING SYSTEM.

17½ feet high by 16 feet wide. This form allows the short sections of about four feet length to be carried through the completed portion by turning their greater diameter at right angles to the greater diameter of the completed tunnel, as shown by dotted lines at M. The tunnel section is fastened to two axles, thus forming a sort of car, and leaving only the axles to be thrown out of the way when the section reaches the interior of the shield, and is detached from them.

A wire rope hoisting gear is attached to the section, and it is raised by steam power and set in its permanent position. The pushing bars are then replaced against it, the pressure applied, and the car which has followed the section into the tunnel is filled, as before described.

After being cast, and before becoming quite cold, the sections are covered externally with a thick rust-proof bituminous preparation. This coating is applied by placing the section on its side with a hoop of sheet-iron of the same width as the section, but of size to leave about half or three-quarters of an inch space for the thickness of the coating. This space is filled with the composition while hot, so that it adheres to both the section and the hoop. While this is done the hoop is held by a frame coinciding with the form of the slightly elliptical opening in the rear of the shield through which it is to pass, so that, regardless of any irregularities in the rough casting of the section, the exterior of the hoop shall be suited to make a good joint in the shield packing, so that the rear of the shield may draw readily off from the hoop, which remains on the section, without allowing openings for irruption of water or mud.

A portion of the coating materials extends to the recess in the end of the section, to form a water tight joint.

force than the backward pressure of the earth heading incident to the weight of the superincumbent column of water and earth, to prevent excavating more material than requisite for the passage of the shield.

Collar, D, is arranged to allow of being taken into the shield with shaft and arm attached, if it is desired to renew the cutters, and means not shown are arranged to prevent silt, etc., pressing into the opening while this is done.

By the use of special cutters on arm, F, rock when not too hard may be tunneled; for instance, a rock known to exist below the Hudson river, and if this rock is as soft as believed by those claiming to know, the cutters would make very good progress through it; but if very hard, it would be desirable, after making a safe entrance within it, to remove parts of the shield head and go on by the usual methods, passing the shield through afterward and following with the iron tunnel.

When work is doing in ground filled with gas like that under the Detroit river, the car should have a tight cover, and its interior should be connected by tube with the ventilating pipe to convey the gas out of the tunnel.

As to the cost of this system, five among the best known expert authorities on a large foundry work agree in estimating the cost of casting the four-foot tunnel sections at less than thirty dollars each, or about seven dollars per lineal foot—this being in addition to the cost of the iron.

As the price of iron varies, no close estimate can be made of its cost. It is believed, however, it would be between \$700,000 and \$900,000 for the pig or scrap iron for two tunnels of length suited to the inclined plane system for the Hudson river. As weight is desirable, very expensive iron

grade to reach the surface not far from the river on the New York side.

A "pusher" or "puller" should be attached to the train at the last stopping place, and as the train approaches the tunnel the locomotive should be switched and the train allowed to enter the tunnel at full speed, running over the long plane to or past the lowest point. On commencing the ascent the motion will be checked, and the train may be stopped by the brakes, and the puller instantly attached to the wire rope, and the train be quickly drawn up into the passenger or freight depot.

A system is now used for lighter trains by which the ropes are attached while both the train and the ropes are running at full and nearly equal speed, and it is believed that this plan can be used for heavy trains by increasing the power of the machinery and the number of wire ropes, thus making the run through the tunnel without a stop. This would probably diminish the time of passage by more than a minute, thus allowing a much greater number of trains to pass daily. For outgoing trains the form of the tunnel should of course be simply reversed, the short incline and the stationary engines being placed at Jersey City. This system is much used, and is doubtless familiar to most readers, but slight modifications would be required.

The tunnels should be *entirely separate*, and at no point less than thirty to fifty feet apart. Fig. 3 indicates the form and approximately the grade of the tunnels for the inclined plane system under the Hudson. The south one represents the tunnel for incoming trains, and the north or upper one that for outgoing trains; the dotted lines simply indicate the horizontal.

HISTORY OF ELEVATED RAILWAYS.

The idea of using an elevated railroad for rapid transit is not of recent origin. In 1812, two years before George Stephenson built his first railroad engine, Col. John Stevens, father of the late millionaires of Hoboken, proposed to run a railroad train by steam in almost exactly the manner now adopted on the elevated railroads of New York. He made a proposition to the Commissioners for the Improvement of Inland Navigation, of which Gouverneur K. Morris was chairman, setting forth his plan in detail and giving facts and figures which showed him to be much further advanced in a practical knowledge of the possibilities attainable in railroad travel than any man of the day. He wrote, in February, 1812, as follows:

"Let a railway of timber be formed, by the nearest practicable route, between Lake Erie and Albany. The angle of elevation in no part to exceed one degree, or such an elevation, whatever it may be, as will admit of wheel carriages to remain stationary when no power is exerted to impel them forward. This railway, throughout its course, to be supported on pillars raised from three to five or six feet above the surface of the ground. The carriage wheels of cast iron, the rims flat with projecting flanges, to fit on the surface of the railways. The moving power to be a steam engine, nearly similar in construction to the one on board the Juliana, a ferryboat plying between this city and Hoboken."

The Juliana above-mentioned was built by Mr. Stevens in 1811. She afterward plied on the Connecticut River, having been the first steamboat to navigate the Sound.

It should be remembered that at that time railroad locomotion was little if any further advanced than aerial navigation is to-day. Both practical men and theorists laughed at the idea that an engine could draw a load heavier than its own weight, and the first locomotives were made with a cogged wheel to work in a cogged rail. Mr. Stevens' plan of an elevated road differs little in its general features from the rapid transit roads on Third and Sixth avenues, except that the height above the surface is greater.

Mr. Stevens' theory was a tremendous leap beyond the knowledge of that day. There were tramways in existence in England, but they were used almost without exception for coal transportation, and had never been thought of for passengers. There were steam road-engines also in use, but they were very heavy, clumsy, and slow machines, intended as traction engines over common highroads, and had nothing in them even to suggest the idea of the railroad locomotive of to-day. Nowhere had any attempt been made to run a locomotive on a line of rails. In the light of later progress in railroad construction, Mr. Stevens' calculations are interesting.

He supported his theory of the practicability of such a road by the following reasons: Its expense would be no greater than that of an ordinary turnpike road with a good coat of gravel on it; it could be built in one or two years; its elevation would remove the timber, of which it was composed, from danger of decay; and travel could never be impeded on it by even the deepest snows; it would be free from the casualties to which canals were liable; and the expense of transportation would be far less than on a canal.

The canal question was at that time the one toward which public attention was directed most forcibly, and therefore all of Mr. Stevens' calculations were comparative, the figures of the Commissioners for the Improvement of Inland Navigation being taken as a basis of comparison. The difference in elevation between Lake Erie and the Hudson at Albany being taken at 225 feet in a distance of more than 300 miles, Mr. Stevens treated it as practically a level road. Taking the capacity of one horse on a railway to be only eight tons, the angle of ascent being less than one degree, Mr. Stevens estimated the power of an engine having a cylinder of 10 inches diameter, with a steam pressure of 50 pounds, to be equal on a similar road to 20 horses, or a capacity to draw 160 tons. But Mr. Stevens, to be on the safe side, took 100 tons, at a speed of 4 miles an hour, as the work to be expected from his engine. Then allowing three cords of wood per day at two dollars a cord, and four men's labor at one dollar each per day, and supposing that full freight was carried only one way, he calculated that the round trip from Lake Erie to Albany and back would be made in five days, which at \$10 per day would make \$50 as the expense of transporting 100 tons the length of the road, or 50 cents per ton. The Commissioners' estimate of the cost by canal was \$3 per ton.

Speaking of the speed attainable, Mr. Stevens said: "I am by no means prepared to say what limits may be set to the rapidity with which a carriage may be driven on these rails."

Elsewhere, first referring to the speed obtained by the native boats, or proas, in the East Indies, Mr. Stevens wrote: "If, then, a proa can be driven by the wind . . . through so dense a fluid as water, at the rate of 20 miles an hour, I can see nothing to hinder a steam carriage from moving on these ways with a velocity of 100 miles an hour;" and in a foot-note: "This astonishing velocity is considered here as merely possible. It is probable that it may not in practice be convenient to exceed 20 or 30 miles an hour. Actual experiments, however, can alone determine this matter, and I should not be surprised at seeing steam carriages propelled at the rate of 40 or 50 miles an hour."

The Commissioners for the Improvement of Inland Navigation replied to Mr. Stevens' memorial, making the following objections: That the engine would not draw such a load for lack of a grip on the rails, for if there was sufficient friction for the engine to take hold, there would be so much more friction under each car, and one would overcome the other; there would also be great friction from the flanges used to keep the wheels on the track, which would be greatly increased if the logs should warp; it would be impossible to build a perfectly "true" railroad with ordinary workmen, and even if built it would easily be thrown out of line by frost and other causes; double tracks would be needed, since the same way would not serve for carriages going and returning, and the expense would thus be doubled; and finally, "it [did] not seem probable that a way could be made of sufficient strength."

Mr. Stevens replied to this highly scientific exposure of the Commissioners' ignorance by showing that an engine, theoretically, would draw such a load as he had estimated; that the roadway could be made true and maintained so at reasonable cost, and that if wood was deemed too perishable or insecure other materials could be used. He then made a detailed estimate of the cost of such a road, having brick pillars, 400 to the mile, with timber ways and iron bar rails four inches broad and one-half inch thick. He thus made the cost per mile as follows:

Bar iron plates.....	\$7,603
Brick pillars.....	1,600
Timber ways.....	1,500
	\$10,703
Or, for the whole 300 miles.....	3,210,900
For reducing elevations, etc.....	500,000
	\$3,710,900

Using stone instead of brick, he added \$800 per mile, or a total of \$3,950,000.

Mr. Stevens informed the Commissioners that the practicability of his plan could be satisfactorily tested for about \$3,000, but whether they thought it too visionary a scheme to deserve attention, or whether their minds were so devoted to the canal project as to be incapable of taking any other ideas into consideration, it is impossible to tell; at any rate they took no further steps and the matter dropped.

Pittsburg's 20-ton Hammer.

One of the largest castings ever made in this country was successfully poured at Pittsburg, October 5, being a solid block of metal weighing 161 tons. Its mission is to serve as the anvil block for a monster steam hammer in process of erection for the Black Diamond Steel Works, Park Brothers & Co., of Pittsburg. The growing demand for steel shafts for Western river steamers was one cause leading to the building of this hammer, whose cost, ready for work, will be \$52,000. The hammer frame will stand 34 feet high, the head, piston, etc., will have a dead weight of 17 tons, increased by steam pressure to 20 tons, and the fall is to be 9 feet.

To properly meet these Titanic blows the great casting was made, the dimensions of the anvil block being as follows: Height, 11 feet; at base, 8 by 10 feet, tapering upwardly to 4 by 6 feet. To secure the best results and toughest metal where this was most needed the block was cast with the smaller end down, and when cooled will be turned over by hydraulic jacks, trunnions forming a portion of the casting for this purpose. The foundations for this anvil necessitated the digging of a pit 27 feet in depth and measuring 30 by 50 feet. Cement piles, surmounted by successive layers of heavy timber, a ponderous cast iron plate, and finally by a section of oak timbers stood upright 11 feet high, form the support for the anvil block. The casting was accomplished in seven hours without accident of any kind, the metal pouring from five cupolas charged with 33 tons each of best charcoal iron. Previous to this work, as near as can be ascertained, no single casting of 100 tons had yet been poured in this country. The Rodman Columbiads, 20 inch bore, cast at Pittsburg in 1860, weighed 80 tons in the rough. As to hammers, the largest steam hammer at present in operation in this country is a 10 ton machine at Nashua, N. H. The Pittsburg hammer is being built by Wm. B. Bement & Sons, Philadelphia, and will be in operation early in the coming year. Western river men will no longer send their orders for steel shafts to Krupp, of Essen.

Balloon Photography.

An interesting experiment has recently been reported to the French Academy of Sciences by M. P. Desmarests. M. Desmarests has succeeded in taking two excellent photographic views from a balloon in mid air. Such views have hitherto been obtained by M. Nadar from a captive balloon, but these are the first from a balloon unattached to the earth. M. Desmarests used the instantaneous process of M. Janssen. The plates were very sensitive, specially prepared with gelatine-bromide, and the oxalate of iron was used in developing them. The views obtained are said to have shown a remarkable clearness. The time of exposure was one-fifteenth of a second.

The Distillation of Spirits.

The following statistics are furnished by the Commissioner of Internal Revenue. The figures indicate the number of gallons of distilled spirits produced, consumed, exported, etc., the fiscal years ending June 30. The marked increase of consumption the past year is attributable to the revival of manufacturing industries, the larger portion of the consumption of spirits in this country being—as is well known to all except prohibition lecturers—used in the arts.

	1880	1879
Production.....	90,355,270	71,892,621
Consumption.....	61,116,523	51,892,714
Exportation.....	16,765,663	14,897,581
Balance in bond.....	31,368,989	19,212,470

The Epidemic of Breakbone Fever in the South.

A painful but fortunately not fatal disease has been very prevalent the past summer along the south Atlantic and Gulf States, from North Carolina to Louisiana, extending into the interior as far as Augusta, Ga. At Charleston, Savannah, and New Orleans the epidemic has been especially severe, the victims being numbered by thousands. Both blacks and whites were affected about equally. For several weeks after the first cases appeared in June the real nature of the disease was not recognized, something like thirty years having elapsed since the last invasion. The symptoms of the disease, as described by Dr. F. P. Porcher, in a communication to the Bulletin of the National Board of Health, are as follows, not all of the symptoms, however, appearing in every case:

The disease generally begins with a feeling of coldness, or by a chill, followed by fever—this, with a temperature ranging from 100° to 105°, lasts generally from 24 to 48 hours, occasionally extending to four or five days, and even in rare cases to seven. Relapses occasional, specially in those who have gone out too early. Headache frequent, generally frontal, from the beginning. Miliary eruptions, sometimes elevated and red, like measles, and the occasional presence of *sudamina* over the face, neck, and body; sometimes the eruptions were confined to the body, and endured for days after recovery. We have seen some examples of slight desquamation—furfuraceous or branny in character. Sweating profuse in many persons, though often absent. Hence, some physicians are inclined to consider the disease to be *suelle miltare* of a mild form. "Breakbone" is the best name, because pain in the bones and limbs is the most constant symptom. There is often great restlessness during the fever, and in some a feeling of tightness or congestion about the throat, with bleeding in a few cases known to us. Catarrhal symptoms are rarely present, although cough has occasionally existed. Bleeding from the nose not unusual in children, and also increase in the menstrual molimen has been observed. Pain in the back and limbs markedly present, but no decided swelling of joints, no carbuncular enlargements or boils, as in the epidemic of Dengue, of 40 years since, or in that of "breakbone," which followed some years subsequently. Weakness and prostration have been very decided, but not nearly to such an extent as in previous epidemics. Some of the physicians consider that there has been a tendency to hepatic torpor or congestion, of no great severity, however. Dr. Porcher has heard of no cases of decided jaundice. Nausea and vomiting seldom occur.

Very little active treatment has been used: a mild laxative, saline or mercurial, hot teas, niter, pediluvia, synapisms, etc., and quinine during and after the attack, upon theoretical grounds, with occasionally mild stimulants. Several persons have recovered with no treatment whatever. No deaths are reported. The disease differed from the Dengue of 40 years ago, and also from the later breakbone fever, in that it seldom or never attacked all the members of a household, as was the case during previous epidemics.

A Successful Case of Transfusion of Blood.

The following case, which exhibits in a marked degree the beneficial effects of transfusion of blood when performed in cases of impending death from excessive hemorrhage, is reported in the *New York Medical Journal*, for August, 1880, by Joseph W. Howe, M.D.:

Mrs. B., aged twenty-two years, was delivered of a three months' fetus, November 7, 1879. From that date until November 11 she had repeated and profuse hemorrhages from the uterus. On the 10th the bleeding was continuous. Drs. Reynolds and Comstock, who were first called in, succeeded in controlling the hemorrhage, but not before the patient had reached the stage of collapse. They remained with her all night, endeavoring, with the ordinary means of stimulation, to rouse her, but without avail. She continued to sink in spite of everything.

On the morning of the 11th I was sent for. The patient was then completely pulseless and partially unconscious. The extremities were cold and clammy, and it was evident that unless some fresh blood were introduced death would soon supervene. She was so far gone that I made up my mind not to spend any time in defibrinating the blood. I opened the median basilic vein in the right arm of the patient and introduced the closed cannula of Colin's instrument, and after passing some warm water through the cylinder of the instrument, attached it to the cannula in the patient's arm. The median cephalic vein in the right arm of the donor was then opened, and the blood was allowed to flow directly into the cylinder without defibrination. When a sufficient quantity had been obtained, and while the blood was still flowing, I injected, without any difficulty, between seven and eight ounces. The whole operation did not occupy more than five minutes in its performance.

Within half an hour the pulse returned at the wrist, the voice became clear and distinct, and she asked for something to eat, saying that she felt stronger and better in every way. One of the medical gentlemen who had been with her all night assisting in the attempts at resuscitation, and who left in the morning, believing that there was no hope of her recovery, came in an hour after the operation, and said it was "a perfect transformation scene"—that he had no idea that a few ounces of blood could restore lost vitality so rapidly.

From that time on the patient continued to improve, and when I last heard from her she was in the enjoyment of good health and attending to her household duties without any discomfort whatever.

HOMICIDE IN THE UNITED STATES.

Some remarkable results have been arrived at by Mr. H. V. Redfield, who has been investigating the frequency of homicide and the treatment of murderers in different parts of the Union. Purposely avoiding years of political excitement, he has endeavored to discover the relative frequency of "ordinary homicide" in the North and the South. In the course of his studies he tabulated the homicides occurring in one or more years in Maine, New Hampshire, Vermont, Rhode Island, Massachusetts, Connecticut, New York, Pennsylvania, Ohio, Michigan, Minnesota, Kentucky, South Carolina, Texas, and other States; also the number of persons charged with murder and manslaughter, and the number of indictments for the various degrees of this crime, for several years, in the States of Maine, Pennsylvania, Michigan, and Minnesota, thus getting the annual average in all these States with a degree of accuracy not previously attained. He selected these States as containing a fairly average population of the Eastern, Middle, and Western States. The average number of indictments annually in all these States, taking a series of years together, was 154. This, however, included the period of the Molly Maguire murders in Pennsylvania.

In like manner he studied the records of the Southern States since the war, finding the homicides in that part of the country from five to ten times more frequent according to population than in the North. The treatment of such crimes in the South, however, was quite unlike that which prevails in the North. In this his statistics amply bear out those furnished recently by the Clerk of the Criminal District Court of New Orleans, in response to the Governor's request. The report is dated September 6, 1880, and was published at length in the *New Orleans Times*. The grand total of crimes of this nature in New Orleans during the ten years ending December 31, 1879, stands thus:

Total homicides.....	303
Guilty of murder and sentenced to death.....	11
Guilty without capital punishment.....	46
Guilty of manslaughter.....	44
Not guilty.....	116
Nolle prosequi.....	59
Not a true bill.....	9
Escapes from justice.....	3
Transferred to dead docket.....	12
Mistrial.....	3
Total.....	303

In the ten years eleven persons were sentenced to be hung for homicide: of these but five were executed—two Italian sailors, entire strangers; one friendless Malay, and two negroes.

Homicide by native whites is not usually punished by death in the South. It is to this circumstance that Mr. Redfield attributes the fact that the murders in the Southern States are greatly in excess of the number elsewhere among English speaking peoples.

Homicide occurs less frequently in New England in proportion to population, and in no part of the country do man-slayers so rarely escape punishment. Fully half the murders in New England are by foreigners. Among the native-born the homicides do not exceed 1 to every 150,000 inhabitants annually. For a period of eleven years the homicides in Vermont averaged less than two a year. In many years not a single homicide has occurred in the State. In 1870 the vital statistics collected by the census showed but one homicide in Vermont and New Hampshire. In Florida, with less than one-third as many inhabitants, there were forty-four homicides. For the State of Massachusetts the annual average is twenty-three, half the murders occurring in Boston, and the larger portion there among foreign born residents.

In the Northern States generally the largest number of homicides occur in the cities: in the South the number is largest in the rural districts. During the two years 1877 and 1878 there were forty homicides in Massachusetts and over two hundred in South Carolina, with less than half the population of Massachusetts. Almost all the South Carolina cases were "personal difficulties," or chance fights from sudden quarrels. To a very great extent the Southern murders are due to the general habit of carrying pistols and using them at the slightest provocation. Touching the benefits that would result from the repression of the habit of carrying concealed weapons, Mr. Redfield cites the example of England, where the number of murders, in proportion to population, has been decreased in the ratio of 18 to 1 in the past four hundred years, and in consequence of a vigorous enforcement of law, at one period going to the extent of affixing capital punishment to the crime of stabbing a person or shooting at him, whether with fatal effect or not. The result was a wholesome diminution of this barbarism. Under the English system a murderer is not allowed to roam around on bail, and the chances of his escaping punishment are very rare indeed. As a consequence, in England and Wales, among the twenty-six millions of population, there are fewer murders and manslaughters than in the single State of Texas, in our own country.

Texas is a large State, but the homicides there are decidedly out of proportion either to its size or the number of its inhabitants. During the census year of 1870 there were more homicides in Texas than in all the Northwestern States combined, with three or four other States thrown in. The census vital statistics show one homicide annually in Texas to about every 2,500 population; in Iowa and Minnesota there is one annually to about every 50,000 population. In this fatal superiority Texas does not greatly lead the sister States of Louisiana, Arkansas, Mississippi, Kentucky, and South Carolina. In one rural county in Kentucky (Madison) the homicides during 1877 and 1878 were more than in all Massa-

chusetts. In Edgefield County, South Carolina, as many men were killed in street fights and personal difficulties in 1878 as there were homicides in Massachusetts, outside of Suffolk County. In the Northern States homicide is least frequent, in proportion to population, in New England and New York (outside New York city) than elsewhere; and probably most frequent in the southern counties of Indiana and Illinois. Homicide is quite frequent in New York city and in the coal and oil regions of Pennsylvania. In Ohio it is very much more frequent in the counties bordering on the Ohio River than in the Northern counties. It is least frequent in the farming counties of the "Western Reserve," where the proportion agrees with that of rural New England.

Open Air for Consumptives.

Dr. J. Henry Bennet, in a communication to the *British Medical Journal*, on the influence of mountain air in the treatment of pulmonary consumption, asserts that the temperature which exerts the most favorable influence in the treatment of phthisis is a day temperature ranging from 55° to 65° or 70° Fah., and a night temperature between 45° and 50°; in other words, that the climate and temperature which are the most conducive to the physiological well-being of the Caucasian race are also the most favorable to the treatment of phthisis. He draws attention to the fact that phthisis is rare among the people inhabiting the high plains of Central and South America, although common in the neighboring seacoast towns. Dr. Comes, with whom Dr. Bennet has lately been in correspondence, states that during a residence of four years in Quito, where he was one of the professors at the medical school, physician to the hospital, and engaged in active private practice, he only saw two or three cases of spontaneous phthisis among the natives, and in all the cases of imported phthisis from the seacoast that he met with the progress of the disease soon appeared to be arrested. He also states that in a large room, without fire, and with doors and windows open day and night, he found the temperature to oscillate all the year round between 57° and 65° Fah.

Dr. Bennet relates the case of a young married lady, aged 26, whom he attended for two winters at Mentone. She was a native of Guayaquil, but educated and married in France, where she became a consumptive; and finding that her recovery at Mentone was only a partial one, she returned to her native country. She has now been two years at Quito, and has become quite well and robust. But then, at Mentone, she lived shut up, while at Quito she has lived in the open air constantly. He therefore thinks that the immunity, or comparative immunity, from phthisis enjoyed by the inhabitants of the elevated mountain plains of tropical and sub-tropical America, from Mexico to the Argentine Republic, cannot be owing to mere elevation—to barometric conditions—inasmuch as phthisis reigns at all elevations, even above 5,000 feet, on the mountains of Switzerland. It cannot, either, be attributed to mere dry cold, as the mortality from phthisis is greater in Norway, Sweden, and Northern Russia than in London or Paris. It must, then, be owing to the ideal physiological climate, which enables the entire population to live, as it were, out doors, in the open air, night and day. Why should not the Andes, with a delightfully mild, dry, and equable climate, which is unequalled in any part of the world, become the health resort of the future?

Characteristics and Properties of Good Vinegar.

H. Krätzer says the quality of vinegar may be detected by its taste, by its color, and by its smell; for instance, good vinegar must have a sour taste, which is not altered by free alcohol or other foreign substances. As to the color; may it be that of the water-clear or of the wine-yellow vinegar, it must always be perfectly pellucid, and when rubbed between the fingers the odor must be acid without having any similarity to spoiled liquors; but before all, vinegar, if brought to the lips, must not produce either an itching or burning, nor give to the teeth a feeling of bluntness, for if this should be the case we can be sure that the vinegar is adulterated.

Adulterations are sometimes produced by the addition of mineral acids, sometimes by vegetable matters. Of the former, especially sulphuric acid, muriatic acid, and sometimes even nitric acid are used; of the latter we mention cayenne pepper, bertram root, common pepper, etc. The method of detecting these adulterations is the following:

If sulphuric acid is suspected of being present we should pour some of the vinegar into a small test tube, and add some chlorate or acetate of barium, if by the addition of this a white color is produced or after a time a white precipitate is formed, then the vinegar has been adulterated with sulphuric acid. If the vinegar only becomes slightly turbid, the reason may be accounted for by the fact that the water which was used for the fabrication of the vinegar contained sulphate of lime. To be certain that the vinegar contains free sulphuric acid the following method should be employed: A small portion of vinegar is put into an evaporation dish and there evaporated until it is condensed to about one-tenth of its weight, the remainder is dissolved in alcohol, filtered, and diluted with water, and finally a solution of chlorate of barium is added. If now the vinegar shows a turbid white color the adulteration by sulphuric acid may be assumed with certainty. Recently, for the detection of mineral acids a new reagent has been devised, which can be well recommended, viz., methyl-aniline-violet. A diluted solution of this substance does not change color at all with pure vinegar, while if the slightest quantity of mineral acids is present it takes a blue-green color.

If an adulteration of muriatic acid is suspected, some drops of a solution of nitrate of silver should be added to the vinegar; if a white, flaky precipitation is formed, which is blackened by the sunlight, and cannot be dissolved after an excess of nitric acid has been added, then the adulteration is proved.

To prove the presence of nitric acid a small quantity of potassium should be mixed with the vinegar, and after the liquid has been evaporated the remainder should be placed upon some glowing charcoal. If decrepitation takes place the adulteration may be taken for granted, otherwise the salt burns without noise and diffuses an odor similar to that of burnt sugar.

To detect the adulteration by sharp vegetable matters the following method may be employed:

A small quantity of the vinegar, having the weight of 150 grains, is slowly evaporated until some brown liquid remains. If it was adulterated, this liquid has a sharp stinging taste, while if this is not the case it will have only an acid taste.

A still more simple method is to moisten the upper lip with vinegar, the purity of which is acknowledged, while the under lip is moistened with the vinegar which is to be examined, and both are permitted to dry. If the vinegar has been adulterated in the manner mentioned a disagreeable itching or stinging is felt on the under lip, while the upper lip is not affected.

A third method for the same purpose is, to neutralize the vinegar by carbonate of soda; the acid taste of the vinegar is thus removed and the sharp taste of spices remains.

If vinegar is kept in copper vessels it is often dangerous to the health. In order to discover whether this has been the case sulphureted hydrogen is employed; if the vinegar first turns a brown color, and if finally a black precipitate is formed, the presence of copper is evident. Vinegar which has been kept in tin vessels gives a yellow precipitate when mixed with sulphureted hydrogen; such as has been kept in zinc vessels gives a white precipitate, and the presence of lead is indicated by a black precipitate.

If iron vessels have been used for the preservation of vinegar the latter loses its value for many industrial purposes. The presence of iron can be detected by the addition of ferrocyanide of potassium, which in this case produces a blue precipitate.

The strength of the vinegar is found in the usual way by means of an acetometer. That of Otto deserves to be recommended.

Recent Telegraphic Progress.

The laying of the new Atlantic cable for the Anglo-American Company gives occasion for a review of recent telegraphic undertakings in other parts of the world, not the least important of which is the laying of the cable between Hong Kong and Manila.

In Europe the most important work projected is, perhaps, the duplication of the Anglo-Danish means of communication by a cable from Newcastle to Arendal in Norway, and thence to Gothenburg in Sweden. Vienna is about to be supplied with underground telegraphic lines after the manner of London, Paris, and Berlin.

On this side the Atlantic several short cables are to be laid by the Canadian Government in the Gulf of St. Lawrence, so as to connect up the lighthouses on the Gulf Islands, notably Anticosti and Sable Island, with the villages of the mainland, and thus facilitate the salvage of shipwrecked vessels. These cables are being made by the Silvertown Company, and will probably be laid this fall. Canada is also bent on finishing her trans-dominion telegraph line, following the route of the Pacific Railroad, and Mr. Sandford Fleming, the engineer-in-chief of that work, has recommended the speedy erection of a line between Fort Edmonton and Cache Creek, so as to complete the communication between Winnipeg in Red River and British Columbia. He further advocates the extension of the Canadian system from Vancouver's Island to Japan by submarine cables via the Aleutian and Kurile Islands; and Mr. Gisborne, the superintendent of Canadian telegraphs, proposes to go still further and unite Japan to Hong Kong and Australia. In Australia itself there is a rapid spread of telegraph lines always going on. A new line is being built from Adelaide to Melbourne, and a cable is to be laid between Sturt's Lighthouse, Kangaroo Island, and Kingscote.

The Western Brazilian Telegraph Company intend to repair and put in working order their long inactive cables between Para, Cayenne, and Demerara. The latest projected work is the laying of a cable between Matamoros, in Texas, the southernmost point of the United States telegraphic system, to Vera Cruz, in Mexico. The line will consist of two sections, one from Matamoros to Tampico, and some two hundred and nine miles long, and the other from Tampico to Vera Cruz, a length of 256 miles. The core will be made of 107 pounds of copper and 166 pounds of gutta percha per mile. The main cable will be sheathed with 12 No. 6 galvanized iron wires and the shore end with 14 No. 1 wires. The insulation resistance of the cable, after five days' submersion, is specified to be 225 megohms per knot at 75° Fah. The temperature of the sea bottom will be tested every fifty miles of the route and one mile from shore at each terminus, the mean of these several observations being taken as the actual temperature throughout. The cable has been designed for the Mexican Telegraph Company, recently formed, by their engineer, Mr. J. B. Stearns, of duplex telegraph fame, and will be laid this year by the contractors, the India-rubber, Gutta Percha and Telegraph Works Company.

Business and Personal.

The Charge for Insertion under this head is One Dollar a line for each insertion; about eight words to a line. Advertisements must be received at publication office as early as Thursday morning to appear in next issue.

Chard's Extra Heavy Machinery Oil. Chard's Anti-Corrosive Cylinder Oil. Chard's Patent Lubricants and Gear Grease. R. J. Chard, Sole Proprietor, 6 Burling Slip, New York.

Now is the best season of the year for painting dwellings, barns, fences, etc., on account of freedom from flies, dust, summer heat, and showers. We are constantly in receipt of letters similar to the following: LAKE VIEW HOUSE, LIVONIA, N. Y., Feb. 9, 1880.

Wanted—The address of all Parties interested in the Silk Business, in all its branches. E. Side, B'klyn, N. Y. Wanted—Second-hand, fifty-inch Lathe, and a large Planer. Perkins & Co., Grand Rapids, Mich.

A profitable business for a person with a small capital. Buy a Stereopticon or Magic Lantern, and an interesting assortment of views. Travel, and give public exhibitions. For particulars, send stamp for 116 page catalogue, to McAllister, Mfg Optician, 49 Nassau St., N. Y.

The E. Stebbins Manuf'g Co. (Brightwood, P. O.), Springfield, Mass., are prepared to furnish all kinds of Brass and Composition Castings at short notice; also Babbitt Metal. The quality of the work is what has given this foundry its high reputation. All work guaranteed.

4 x 6 Engine and Boiler for sale. Geo. F. Shedd, Waltham, Mass. The "1880" Lace Cutter by mail for 50 cts.; discount to the trade. Sterling Elliott, 262 Dover St., Boston, Mass. On an allowed Home Patent.—Wanted co-operation on Foreign Patent. Address Trio, Box 62, Austin, Texas.

Hardware Novelty.—Entire U. S. Patent for sale cheap. Address F. A. Heberline, Knox Clarion Co., Pa. The Tools, Fixtures, and Patterns of the Taunton Foundry and Machine Company for sale, by the George Place Machinery Agency, 121 Chambers St., New York.

For Sale, on account of increase of power, one 24 x 48 Corliss Engine, with three boilers and equipment complete. Now in use, but deliverable in November next. For particulars address Natchez Cotton Mills Company, Natchez, Miss.

Improved Rock Drills and Air Compressors. Illustrated catalogues and information gladly furnished. Address Ingersoll Rock Drill Co., 1 1/2 Park Place, N. Y. Collection of Ornaments.—A book containing over 1,000 different designs, such as crests, coats of arms, vignettes, scrolls, corners, borders, etc., sent on receipt of \$2. Palm & Fechteler, 403 Broadway, New York city.

The Eureka Mowing Machine now is acknowledged as the best in the market. It has taken the first premium in nearly every State Fair this year. Prices to suit the times. Send for illustrated circular to Eureka Mower Company, Towanda, Pa.

The Boomer & Boschert Press Co. have in daily operation, at the Am. Inst. Fair, a complete cider mill and cider jelly manufactory. New York Office, 15 Park Row. Packing once tried always used. Phoenix Packing from 1-16 up in spools or on coils. Phoenix Packing Company, 108 Liberty St., N. Y.

Gas Machines.—Be sure that you never buy one until you have circulars from Terri's Underground Meter Gas Machine, 39 Dey St., New York. Experts in Patent Causes and Mechanical Counsel. Park Benjamin & Bro., 50 Astor House, New York.

Caution to the Public.—The world-wide reputation of H. W. Johns' patent Asbestos Steam Pipe and Boiler Coverings has induced unscrupulous persons to infringe our rights, and also to sell and apply worthless articles, representing them as being made of Asbestos.

Wright's Patent Steam Engine, with automatic cut off. The best engine made. For prices, address William Wright, Manufacturer, Newburgh, N. Y. 4 to 40 H. P. Steam Engines. See adv. p. 252. Rollstone Mac. Co.'s Wood Working Mach'y ad. p. 237.

National Institute of Steam and Mechanical Engineering, Bridgeport, Conn. Blast Furnace Construction and Management. The metallurgy of iron and steel. Practical Instruction in Steam Engineering, and a good situation when competent. Send for pamphlet. Wm. Sellers & Co., Phila., have introduced a new injector, worked by a single motion of a lever.

Reed's Sectional Covering for steam surfaces; any one can apply it; can be removed and replaced without injury. J. A. Locke, Agt., 32 Cortlandt St., N. Y. For Yale Mills and Engines, see page 252. Machine Knives for Wood-working Machinery, Book Binders, and Paper Mills. Also manufacturers of Solomon's Parallel Vise, Taylor, Stiles & Co., Riegelsville, N. J.

Portable Railroads. Sugar Mills. Horizontal & Beam Steam Engines. Atlantic Steam Engine W'ks, B'klyn, N. Y. Peck's Patent Drop Press. See adv., page 268. Blake "Lion and Eagle" Imp'd Crusher. See p. 269. Apply to J. H. Blaisdell for all kinds of Wood and Iron Working Machinery. 107 Liberty St., New York. Send for illustrated catalogue.

Houston's Sash Dovetailing Machine. See ad., p. 270. The Chester Steel Castings Co., office 407 Library St., Philadelphia, Pa., can prove by 15,000 Crank Shafts, and 10,000 Gear Wheels, now in use, the superiority of their Castings over all others. Circular and price list free. Brass & Copper in sheets, wire & blanks. See ad. p. 270. Air Compressors. Clayton Stm. Pump W'ks, B'klyn, N. Y. Diamond Saws. J. Dickinson, 64 Nassau St., N. Y.

The Improved Hydraulic Jacks, Punches, and Tube Expanders. R. Dudgeon, 24 Columbia St., New York. H. A. Lee's Moulding Machines, Worcester, Mass. The "Fitchburg" Automatic Cut-off Horizontal Engines. The "Haskins" Engines and Boilers. Send for pamphlet. Fitchburg Steam Engine Co., Fitchburg, Mass. Eagle Anvils, 10 cents per pound. Fully warranted. Gear Wheels for Models (list free); experimental and model work, dies and punches, metal cutting, manufacturing, etc. D. Gilbert & Son, 212 Chester St., Phila., Pa.

The best Truss ever used. Send for descriptive circular to N. Y. Elastic Truss Co., 683 Broadway, New York. New Economizer Portable Engine. See illus. adv. p. 269. For Shafts, Pulleys, or Hangers, call and see stock kept at 79 Liberty St., N. Y. Wm. Sellers & Co. Saw Mill Machinery. Stearns Mfg. Co. See p. 269. Ore Breaker, Crusher, and Pulverizer. Smaller sizes run by horse power. See p. 269. Totten & Co., Pittsburg. Vacuum Cylinder Oils. See adv., page 269. Lightning Screw Plates and Labor-saving Tools, p. 269.

Names and addresses of correspondents will not be given to inquirers. We renew our request that correspondents, in referring to former answers or articles, will be kind enough to name the date of the paper and the page, or the number of the question. Correspondents whose inquiries do not appear after a reasonable time should repeat them. If not then published, they may conclude that, for good reasons, the Editor declines them.

Persons desiring special information which is purely of a personal character, and not of general interest, should remit from \$1 to \$5, according to the subject, as we cannot be expected to spend time and labor to obtain such information without remuneration. Any numbers of the SCIENTIFIC AMERICAN SUPPLEMENT referred to in these columns may be had at this office. Price 10 cents each.

(1) H. A. asks: How can I fix a mirror from which some of the quicksilver has been scratched? A. Remove the silvering from the glass around the scratch so that the clear space will be about a quarter of an inch wide. Thoroughly clean the clear space with a clean cloth and alcohol. Near the edge of a broken piece of looking glass mark out a piece of silvering a little larger than the clear space on the mirror to be repaired. Now place a very minute drop of mercury on the center of the patch and allow it to remain for a few minutes, clear away the silvering around the patch, and slide the latter from the glass. Place it over the clear spot on the mirror, and gently press it down with a tuft of cotton. This is a difficult operation, and we would advise a little practice before trying it on a large mirror.

English Patents Issued to Americans. From September 28 to October 1, 1880, inclusive. Blacking brush, E. L. Wood, Eastland City, Texas. Compound for preventing pain, H. E. Dennett, Boston, Mass. Electricity, apparatus for generating, E. Thomson, New Britain, Conn. Electricity, conductors for, T. A. Edison, Menlo Park, N. J. Electro-magnetic railways, T. A. Edison, Menlo Park, N. J. Engines for locomotives, F. M. Stevens et al., Concord, N. H. Hoisting machinery, A. E. Brown, Cleveland, Ohio.

Magneto-electric machine, T. A. Edison, Menlo Park, N. J. Mail bag, C. J. Becket et al., Muncie, Ind. Pianoforte, A. Hellig, Little Ferry, N. J. Rail for railway, E. Rider, New York city. Soap, manufacture of, A. Bastel, Brooklyn, N. Y. Telephone, A. G. Bell, Washington, D. C. Type setting machine, J. Thorne, Port Richmond, N. J. Type writing machine, A. M. Da Costa, Brooklyn, N. Y.

INDEX OF INVENTIONS

FOR WHICH Letters Patent of the United States were Granted in the Week Ending September 28, 1880, AND EACH BEARING THAT DATE. [Those marked (r) are reissued patents.]

A printed copy of the specification and drawing of any patent in the annexed list, also of any patent issued since 1866, will be furnished from this office for one dollar. In ordering please state the number and date of the patent desired and remit to Munn & Co., 37 Park Row, New York city. We also furnish copies of patents granted prior to 1866; but at increased cost, as the specifications not being printed, must be copied by hand.

Table listing inventions with patent numbers and names. Includes items like Acid from sludge acid, recovering sulphuric, E. Clark; Air engine, E. Thiemmler; Annunciator for fire alarm telegraphs, F. W. Griswold; Angers, manufacture of mining, D. W. Siprell; Axle box, car, W. G. Mitchell; Ball trap, Kerstetter & Fagley; Basket, folding, H. H. Cammann; Basket, metallic, J. B. F. Page; Bath chamber, portable, J. N. Lee; Bed bottom, spring, J. M. Stark; Bedstead, folding, S. S. Burr (r); Blasting, R. F. L. Hallock; Boot and shoe lining, A. M. Daniels; Bosom board, H. S. Foster; Bottle stopper, P. Miles; Brick machine, rotary, Smith & Glaze; Brush for cleaning castings, J. H. Davis; Brush, helical wire, F. F. Field; Bucket bottom, well, Johnson & Eccleston; Bumper, spring, R. W. Irwin; Bung for beer kegs, faucet, C. H. Shaw; Burglar alarms, indicator for electric, A. Bradford; Calendar, F. Ratcliff (r); Cant hook, M. Bellanger; Car coupling, D. S. Bailey; Car coupling, J. Candy; Car coupling, J. Coart; Car door, D. F. Van Liew; Car, sleeping, T. Clarke; Car, stock, L. Leber; Car, stock, S. H. McGibeny; Car, stock, L. D. Smith; Cars, etc., grain spout for loading, J. Coleman; Cars, mechanism for propelling, A. Sanford; Carpet sweeper, W. J. Drew; Carriage bow, E. M. Driscoll; Carving implement, C. Keyworth; Chimney ventilator, J. C. Henderson; Chisel for wood turning, gauge, T. S. Durgin; Churn, J. H. Holmes; Clay digger, C. Bush; Coal hod, W. S. Salisbury; Cock, gauge, C. Jenkins; Coffee pulper and separator, E. L. Henington; Coffee ripening apparatus, J. Bininger; Coin counter and changer, P. Clark; Collar fastening, horse, S. J. Bowers; Compass, mariner's, W. Thomson; Cooker, steam, E. Gallaher; Cornice bracket, H. L. Judd; Cotton condenser, F. H. Lummus; Coupling, W. J. Innis; Curtain fixture, A. B. Shaw; Cutlery handle, folding, H. M. Barrows; Dental plugger, G. M. Renn; Desk, accountant's or bookkeeper's, W. W. Underhill; Desk, writing, J. Peard; Ditching machine, I. C. Covert; Door bolt, double, W. P. Brachmann; Door hanger, L. Terry; Drop light gasalier, J. E. Brown; Edger, gang, W. J. Perkins; Electric light for burglar alarms, C. E. Buell; Elevator, Fitts & Griffin; Elevator cages, safety attachment for, P. Hinkle; Fabrics, device for cutting, F. R. Lewis; Fare box, G. W. Horne; Faucet, J. P. Gruber; Fence, farm, T. W. Owens; Fermenting vat, M. V. Monarch; Fertilizer, H. M. Pollard; Filter, B. T. Loomis; Firearm, magazine, J. H. Salter; Fireplace lining, J. B. Witherspoon; Fish hook wrapper, G. G. Gregory; Folding chair, J. T. Mitchell; Fruit drier, M. J. Dorsett; Furnace, U. Cummings; Game apparatus for lawn bowling, E. W. Haines; Gas lighting apparatus, electric, J. P. Tirrell; Gas machine, A. Henning; Gate, Harbaugh & Owen; Gearing, cog, R. H. McNair; Grain register, W. B. Richardson; Grain separators, sieve for, J. A. Olson; Grinding mill, J. T. Case; Grinding mill, Swisher & Mershon; Harrow, S. Harris; Harrow, W. Rucker, Sr.; Harvester, W. H. Davis; Harvester seats, safety device for, W. J. & A. R. Shaw; Hinge, J. T. Morgan; Hoe, F. J. Fischer; Hominy mill, C. S. Day; Hydrant, E. Kuchling; Hydraulic engine, I. C. Smith; Insecticide pastille, J. J. Detwiler; Insulators, forming, J. M. Brookfield (r); Iron, tool for cutting plate, W. T. Bennett.

Table listing inventions with patent numbers and names. Includes items like Jug, covered, I. W. Knowles; Label, tobacco, P. J. Sorg; Lamp chimneys, mechanism for opening the base of, J. Adams; Lamp, electric, J. C. Jamin; Lamp, reservoir, O. Sweeney; Lamp supporting device, A. Roelofs; Lead and crayon holder, A. C. Hafely; Liquid drawing and measuring device, S. W. Cox; Locomotive, F. M. Stevens; Locomotive exhaust apparatus, E. Longstreth (r); Locomotive fire box, Taylor & Burgess; Mat, J. H. Robertson; Meat, fruit, etc., press, B. A. Stevens; Microphone, J. P. Livermore; Milliner's steamer and presser, T. Hicks, Jr.; Millstone dress, A. D. Farling; Mining machine, G. D. Whitcomb; Mop head, J. K. Collins; Nail extractor, A. F. Gerald; Nickel plating, solution for, C. G. Pendleton; Nickel plating, solution for the electro-deposition of, J. H. Potts; Ore crusher frame, E. S. & H. H. Blake; Oyster float, T. McCosker; Packing band, J. Z. Gifford; Painting pottery, T. J. Wheatley; Paper, machine for waxing or varnishing, J. W. Sutton; Peg and peg wood, F. F. Raymond, 2d.; Pen, cattle, J. N. Chew; Pen, stylographic fountain, C. H. Downes; Pencil sharpener, slate, J. W. Hyatt; Pencils, machine for the manufacture of slate, J. W. Hyatt; Plaited puffing, machine for making, S. E. Barney (r); Plow and seed planter, combined listing, Cooper & Bostwick; Plow attachment, C. E. Worline; Polishing machine, M. R. Chase; Printing machines, ink roller attachment for, G. A. Miller; Printing surface, W. C. Walter; Pulley, belt, W. J. Fetter; Pump, G. S. Bartlett; Pump, W. Burlingham; Pump valve, A. K. Rider (r); Pumping apparatus, vacuum, Frings & Müller; Reapers, attachment for, G. W. Looney, Sr.; Rock drill, S. Hussey; Rolling mill, C. Erdmann; Roofing, H. W. Hoefft; Rope coils, rack and spool for holding, C. J. Le Roy; Rotary steam engine, C. S. Whitney; Saddle horn, Rubarts & Dubrulle; Saddle, military, J. R. Hastings; Saddle, pack, T. A. Kelly; Safe, sectional kitchen, C. Spier; Sample exhibitor, G. S. Griffith, Jr.; Sash fastener, J. Harley; Saw filing machine, gin, D. T. Burden; Scraper, revolving sulky, W. C. Marr; Screw cutting die stock, Walker & Williams; Seeding machine, S. Hoke; Sewing machine operating mechanism, G. W. Zeigler; Ships, construction of, J. W. Sadler; Shirt bosom, S. K. Devereux; Shoe nail, S. Moore; Shutter fastener, A. M. Walker; Soldering apparatus, J. Campen; Sower, seed, T. B. Rogers; Spectacle frame, Willson & Meigs; Stamp, hand, Keith & Philp; Steam generator, F. M. Stevens; Steel blooming and slabbing mill, J. Hemphill; Stereoscope, Pagliugh & Ardito; Stocking suspender, child's, H. F. Bowman; Stool or chair, J. M. J. Wernert; Stump extractor, E. O'Neill; Suspenders, J. A. Adamson; Telegraph box, fire alarm, G. A. Gawler; Telegraph, multiple, H. C. Nicholson; Telephone, C. E. Buell; Telegraph alarms, cut out for, Barker & Edmonston; Telephone circuit, T. A. Watson; Telephone, speaking, W. Gillett; Telephone stand, T. A. Watson; Time detector, watchman's, W. Imhaeuser (r); Time lock, B. F. Flint; Toy bank, G. W. Eddy; Toy moulding apparatus, J. A. Crandall; Toy money box, J. H. Bowen; Toy pistol, H. A. Smith; Traction engine, J. F. Marks; Trunk, C. F. Clapp; Type writing machine, A. M. Da Costa; Type writing machine, C. McKinley; Type writing machines, paper presser for, J. H. Pratt; Urn for the reception of the ashes of the dead, E. C. Townsend; Valve gear, steam engine, F. M. Stevens; Valve, rotary, F. M. Stevens; Valve, safety, J. Griswold; Vehicle spring, A. Tetu; Vehicle, spring, G. White; Vehicle top joint, J. A. Nisonger; Velocipede, C. M. Trautmann; Velocipede, Tripler & Roff; Vent plug for barrels, etc., A. Zoller; Wagon, buckboard, L. Sanford; Washing machine, L. Becker; Watch, stop, H. A. Lugin; Web winding machine, G. Rosquist; Whale blubber, machine for mincing, P. Cunningham; Whip snap, Bohler & Phinney; Wind engine, J. R. Brink; Winding mechanism for going barrels, E. Wright; Window frame pocket, H. D. Pursell; Window screen, J. Joseph.

DESIGNS. Book, Christmas, H. E. Manchester; Door mat, rubber, A. O. Bourn; Sewing machine case, E. Genee; Sewing machine case, J. Stephan.

TRADE MARKS. Beer, F. Dittmer; Bitters, herbal, W. H. Beasley; Blacking and polish, T. Y. Kelley; Cigars, cigarettes, cheroots, and plug, smoking, and chewing tobacco, Kinney Tobacco Company; Plow, Gale Manufacturing Company.

Advertisements.

Inside Page, each insertion --- 25 cents a line. Back Page, each insertion --- \$1.00 a line.

A Chance for the Amateur Astronomer. You can make your own telescopes by getting a silvered glass specula and diagonal and mounting them yourself.

MUNSON BROTHERS. PATENT EYE AND SPINDLE. PORTABLE MILLS. PATENT HOLLOW NECKED SPINDLE AND OIL TIGHT BUSH.

UNITED STATES PATENT RIGHTS OF THE INVICIOUS PLATEN PRINTING MACHINE FOR SALE.

The BEST are CHEAPEST. Our New No. 3 FLEETWOOD and DEXTER-C SCROLL SAWS.

THE SUN.—BY PROF. S. P. LANGLEY, of the Allegheny Observatory, Pa.—A valuable and instructive series of articles, giving an account of all that has been discovered in regard to our luminary up to the present date.

CORRUGATED AND CRIMPED IRON ROOFING AND SIDING. Iron Buildings, Roofs, Shutters, Doors, Cornices, Skylights, Bridges, etc.

INVENTORS WANTED, LIGHT MECHANICAL ARTICLES OF BRASS OR IRON TO MANUFACTURE ON ROYALTY OR OTHERWISE.

DRAWING INSTRUMENTS. Swiss, German Silver, and Brass of the best make. Drawing Paper, Paints, and Materials.

EMPIRE FORGES—THE BEST. EMPIRE PORTABLE FORGE CO., COHOES, N. Y.

PROSPECTING MINERAL LANDS A SPECIALTY. CYLINDRICAL SECTIONS OR CORES OBTAINED THE WHOLE DISTANCE BORED.

THE COPYGRAM. Aniline Process, Pat'd Dec 23, 1873. The Auto-Lithograph. Printing Ink Process, Pat'd May 19, 1874.

Pulley Blocks. Iron Sheaves, Phosphor Bronze Sheaves, Lubricating Bushings, PENFIELD BLOCK WORKS.

NEW EDITION. WEBSTER'S UNABRIDGED DICTIONARY WITH SUPPLEMENT. Published by G. & C. MERRIAM, Springfield, Mass.

PLANING AND MATCHING MACHINE. A Reliable Thermometer SENT FREE to any address for 25 cts.

THE DIAMOND—ITS ORIGIN, ARTIFICIAL PRODUCTION, AND USES.—By Henry A. Mott, Jr., Ph.D. An interesting and instructive paper, giving a resume of all the facts in regard to natural diamonds.

TOOLS FOR MECHANISTS, CARPENTERS, AMATEURS, JEWELLERS, MODEL MAKERS, BLACKSMITHS, ETC.

\$5 to \$20 per day at home. Samples worth \$5 free. Address STINSON & Co., Portland, Me.

The National Institute of Steam Engineering, Bridgeport, Conn., can furnish, Nov. 1, a number of sober, reliable, and trustworthy Engineers.

ELEVATORS. All kinds of Hoisting Machinery a Specialty. Steam, Hydraulic, and Belt Power.

AIR COMPRESSORS. THE NORWALK IRON WORKS CO., SOUTH NORWALK, CONN. FOR SALE.

MAGIC LANTERNS AND VIEWS. THE MAGICAL ORGANETTE, ONLY \$8.00. Double size Reeds, extra strength and finish.

SEND FOR THE BEST BAND SAW BLADE in the market to LONDON, BERRY & ORTON, Phila., Pa.

MAGIC LANTERNS AND VIEWS. THE MAGICAL ORGANETTE, ONLY \$8.00. Double size Reeds, extra strength and finish.

TOY NOVELTIES IN WOOD WANTED.—Will buy or manufacture on royalty. HAWES BROTHERS, Monroeton, Pa.

BIG PAY to sell our Rubber Printing Stamps. Samples free. Taylor Bros. & Co., Cleveland, O.

MUSTACHE AND WHISKERS. Dyer's Beard Lint and will do on either bald head or bare face.

AGENTS WANTED. \$5 PER DAY made selling our PLATFORM FAMILY SCALE.

THE FRICTION CLUTCH CAPTAIN. can be applied to all classes of machinery that is driven by fly-wheels and are liable to be broken by power stored up in wheel, such as calendar rolls, upsetting machines, presses, and wire drawing machines.

SURFACE FILE HOLDERS. By their use a crooked file may be utilized as well as a straight one, and both are made to do better execution in filing broad surfaces than has hitherto been possible.

THE HOLLY SYSTEM OF STEAM HEATING. SYSTEM OF STEAM HEATING. LOCKPORT N.Y.

Pond's Tools, Engine Lathes, Planers, Drills, &c. DAVID W. POND, Worcester, Mass.

A Reliable Thermometer SENT FREE to any address for 25 cts. Or a Barometer and Thermometer Combined, that foretells correctly any changes in the weather 12 to 24 hours in advance.

Superior Wood Working Machinery, principally for Cabinet, Piano, and Piano Action Makers.

FORCED ALIMENTATION.—BY ALEXANDER HUTCHINS, M.D. A very suggestive paper, in which the author takes issue with the popular opinion that food should not be taken when the desire for it does not exist.

THE NEW OTTO SILENT GAS ENGINE. Useful for all work of small stationary steam engine. Built in sizes of 2, 4, and 7 H. P.

OLD RELIABLE. NO FAILURE IN SIXTEEN YEARS. HEALD & SISCO, CENTRIFUGAL PUMPS.

PROGRESS OF INDUSTRIAL CHEMISTRY.—By J. W. Mallet. A brief review of the most important changes in the industrial applications of chemistry within the last few years.

ELGIN WATCHES. All styles, Gold, Silver and Nickel, \$6 to \$150. Chains, etc., sent C. O. D. to be examined.

Wheeler's Patent Wood Filler fills the pores of wood perfectly, so that a smooth finish is obtained with one coat of varnish.

ELEVATORS. HAND POWER AND HYDRAULIC. FREIGHT & PASSENGER. SHAFTING-PULLEYS & HANGERS.

HARDENING, TEMPERING, AND ANNEALING OF STEEL.—A series of reports made to the Research Committees of the Institution of Mechanical Engineers.

ALAND'S Silent Injector, Blower & Exhauster. Apply to S. ALAND, Rome, Onondaga Co., N. Y.

AGENTS WANTED. \$5 PER DAY made selling our PLATFORM FAMILY SCALE. Weighs up to 25 lbs. Retail price, \$2. A BOOM FOR AGENTS.

CARNEGIE BROS & CO. UNION IRON MILLS. PITTSBURGH PA. WROUGHT IRON BEAMS. CHANNELS TEES & ANGLES.

THE ATTENTION OF ARCHITECTS, ENGINEERS, AND BUILDERS IS CALLED TO THE GREAT DECLINE IN PRICES OF WROUGHT STRUCTURAL IRON.

THE ACME CUBE PIPE TONGS. VARYING SIZES FROM 1/4 TO 4 INCH. MOST EFFICIENT MADE.

THE CHEMISTRY OF BREAD MAKING.—By Prof. Graham, D.Sc. A recent lecture before the London Society of Arts, treating of the peculiarities of ovens, the chemical changes which take place in the loaf during baking.

VIOLIN OUTFITS. Consisting of Violin, Bow, and Teacher. Sent to any part of the United States on 1 to 3 days trial before buying.

To Electro-Platers. BATTERIES, CHEMICALS, AND MATERIALS, in sets or single with Books of Instruction for Gold, Silver, or Nickel Plating.

STEEL STAMPS. STEEL LETTERS. STEEL DIES, &c. 87 NASSAU ST. N.Y.

TELEPHONE Works 1 mile. Circulars free. HOLCOMB & Co., Mallet Creek, Ohio.

HUB MACHINERY.—HUB TURNING, HUB MORTISING, and Hub Boring Machines. Send for price list and circulars.

\$72 A WEEK. \$12 a day at home easily made. Costly outfit free. Address TRUB & Co., Augusta, Me.

GREAT WESTERN GUN WORKS, Pittsburgh, Pa. Rifles, Shot Guns, Revolvers, sent c. o. d. for examination.

SCIENTIFIC AMERICAN SUPPLEMENT. Any desired back number of the SCIENTIFIC AMERICAN SUPPLEMENT can be had at this office for 10 cents.

ORGANS. 14 Stops, 4 Sets Reeds, only \$65. Pianos, \$125 up. Paper free. Address Daniel F. Beatty, Washington, N.J.

MANVILLE PATENT PLANERS AND SHAPERS. HENDEY MACHINE CO. WOLCOTTVILLE CONN. SEND FOR CATALOGUE.

THE BEST PAPER! TRY IT! THE SCIENTIFIC AMERICAN. Has been the foremost of all industrial publications for the past Thirty-Four Years.

Every number contains from 10 to 15 original engravings of new machinery, novel inventions, Bridges, Engineering works, Architecture, improved Farm Implements, and new discoveries in Chemistry.

TERMS:—One Year, by Mail, \$3 20. Six Months, 1 60. Address and remit to MUNN & CO., Publishers, 37 Park Row, New York.

Patents obtained on the best terms in all countries. Models of new inventions and sketches examined, and advice free.

MUNN & CO., No. 37 PARK ROW, NEW YORK. Branch Office, cor. F & 7th Sts., Washington, D. C.

RUSSELL'S COMMON SENSE BINDER. BINDS books, papers, magazines, music, letters, or loose sheets. Contents removed or replaced at will.

RUSSELL'S COMMON SENSE BINDER. BINDS books, papers, magazines, music, letters, or loose sheets. Contents removed or replaced at will.

Valuable and Indispensable Practical and Scientific Books.

- LIST NO. 2.
- Callingham. Sign Writing and Glass Embossing. Illustrated. 12mo. Cloth. \$1.50
 - Campin. Practical Treatise on Mechanical Engineering. Illustrated with 29 plates and 100 wood engravings. 8vo. Cloth. \$6.00
 - Campin. Practice of Hand Turning in Wood. Ivory, Shell, etc. Illustrated. 12mo. Cloth. \$2.00
 - Carey. Principles of Social Science. 3 vols. 8vo. \$10.00
 - Carey. Manual of Social Science. 12mo. \$2.25
 - Cabinet Maker's Album of Furniture. 43 plates. Oblong. Cloth. \$3.50
 - Clark. Tramways, their Construction and Working. Illustrated by over 100 engravings and 13 plates. 8vo. Cloth. \$7.50
 - Colburn. The Locomotive Engine. Illustrated. 12mo. Cloth. \$1.25
 - Crak. The Practical American Miller and Millwright. Illustrated by wood engravings and folding plates. 8vo. Cloth. \$5.00
 - Copper. Universal Stair Builder. 29 plates. 4to. Cloth. \$2.50
 - Cooley. Complete Practical Treatise on Perfumery. 12mo. Cloth. \$1.50
 - Cristiani. Perfumery and Kindred Arts. Illustrated. 8vo. Cloth. \$5.00
 - Cristiani. The Manufacture of Soap and Candles. 8vo. (In press.)
 - Crookes. A Practical Handbook of Dyeing and Calico Printing, with 11 page-plates, 47 specimens of Fabrics, and 38 wood-cuts. 730 pages. 8vo. Cloth. \$15.00
 - Crookes. Select Methods in Chemical Analysis (chiefly inorganic). Illustrated. 12mo. 468 pages. \$5.00
 - Cummings. Architectural Details, containing 387 designs and 387 illustrations. 4to. \$6.00
 - Davidson. A Practical Manual of House Painting, Graining, Marbling, and Sign Writing. 9 colored illustrations of water and marbles, and numerous wood-cuts. 12mo. Cloth. \$3.00
 - Davies. A Treatise on Slate and Slate Quarrying. Numerous Illustrations. 12mo. Cloth. \$3.00
 - Davies. A Treatise on Metalliferous Minerals and Mining. Illustrated with numerous wood engravings. 12mo. Cloth. Just ready. \$5.00
 - DeGraft. The Geometrical Stair Builder's Guide. 22 steel plates. 4to. Cloth. \$5.00
 - DeKoninck. Dietz. A Practical Manual of Chemical Analysis and Assaying as Applied to the Manufacture of Iron from its Ores, and to Cast Iron, Wrought Iron, and Steel as found in Commerce. American Edition. Edited by Fesquet. Illustrated. 12mo. Cloth. \$2.50
 - Donaldson. Drawing and Rough Sketching for Marine Engineers. Illustrated. 12mo. Cloth. \$2.25
 - Duncan. The Practical Surveyor's Guide. 12mo. Cloth. \$1.25
 - Dupuis. A Treatise on the Distillation and Manufacture of Alcoholic Liquors. Illustrated by 14 folding plates and several wood-cuts. 743 pp. 8vo. Cloth. \$10.00
 - Dussauce. Practical Treatise on the Fabrication of Matches, Gun Cotton, and Fulminating Powder. 12mo. Cloth. \$1.44
 - Dussauce. Treatise on the Art of Tanning, Currying, and Leather Dressing. 212 wood-cuts. 8vo. Cloth. \$25.00
 - Dussauce. A General Treatise on the Manufacture of Soap of every description. Numerous illustrations. 8vo. Cloth. \$7.50
 - Dussauce. A General Treatise on the Manufacture of Vinegar. Illustrated. 8vo. Cloth. \$5.00
 - Dyer and Color Maker's Companion. 12mo. Cloth. \$1.25
 - Easton. A Practical Treatise on Street or Horse Power Railways. 23 plates. 8vo. Cloth. \$3.00
 - Edwards. A Catechism of Marine Steam Engine, for the Use of Engineers, Firemen, and Mechanics. A Practical Book. For the Use of Practical Men. Illustrated by 60 engravings, including examples of the most modern Engines. 2d edition. 12mo. Cloth. Just ready. \$2.00
 - Eider. Questions of the Day, Economic and Social. 8vo. Cloth. \$3.00
 - Fairbairn. The Principles of Mechanism and the Machinery of Transmission: comprising the Principles of Mechanism, Wheels, and Pulleys, Strength and Proportions of Shafts, Coupling of Shafts, and engaging and disengaging Gear. Illustrated by 150 wood-cuts. 12mo. Cloth. \$2.50
 - Fleming. Narrow-Gauge Railways in America. Illustrated. 8vo. Cloth. \$1.50
 - Forsyth. Book of Designs for Headstone, Mural, and other Monuments. 75 designs. 4to. Cloth. \$5.00
 - Galloway. Gas Fitter's and Plumber's Guide. 12mo. Cloth. \$1.00
 - Gothic Album for Cabinet Makers. 23 plates. Oblong. \$2.00
 - Gee. The Practical Gold Worker. Instructor in Art of Alloying, Melting, Reducing, Coloring, and Refining. Manipulation, Recovery of Waste, Chemical and Physical Properties of Gold, Silvers, Enamels, and other useful Rules and Recipes. 12mo. Cloth. \$3.50
 - Gee. The Silversmith's Hand Book, containing Instructions for Alloying and Working of Silver, including refining and melting its solders, preparation of imitation alloys, manipulation, prevention of waste, instructions for improving and finishing the surface of the work, with other useful information. Illustrated. 12mo. Cloth. \$3.50
 - Gregory. Mathematics for Practical Men. Plates. 8vo. Cloth. \$5.00
 - Griswold. Railroad Engineer's Pocket Manual for the Field. 12mo. Tucks. \$1.75
 - Grier. Rural Hydraulics: A Practical Treatise on Rural Household Water Supply. Illustrated. 8vo. Cloth. \$0.75
 - Guetter. Metallic Alloys. A Practical Guide to their Chemical and Physical Properties, Preparation, Composition, and Uses. 12mo. Cloth. \$3.00
 - Gibson. The American Dyer. A Practical Treatise on the Coloring of Wool, Cotton, Yarn, and Cloth, with 94 samples of colored wool, waste, etc. 8vo. Cloth. \$6.00
 - Gruner. Studies of Blast Furnace Phenomena. Illustrated. 8vo. Cloth. \$2.50
 - Hats and Felting. A Practical Treatise on their Manufacture. 8vo. Cloth. \$1.25
 - Hofmann. A Practical Treatise on the Manufacture of Paper in all its branches. Illustrated by 110 wood engravings and 5 folding plates. 4to. Cloth. 400 pp., \$15.00
 - Hughes. The American Miller and Millwright's Assistant. 12mo. Cloth. \$1.50
 - Hughes. A Treatise on Water Works for the Supply of Cities and Towns. 12mo. Cloth. \$2.00
 - Hughes. A Treatise on Gas Works and the Practice of Manufacture and Distribution of Coal Gas. 12mo. Cloth. \$1.75
 - Haserick. The Secrets of the Art of Dyeing Wool, Cotton, and Linen, including Bleaching and Coloring Wool and Cotton, Hosiery and Random Yarns. A Treatise based on economy and practice. Illustrated by 323 Dyed Patterns of Yarns and Fabrics. 1 vol. 8vo. \$25.00
 - Henry. The Early and Later History of Petroleum. Illustrated. 8vo. Cloth. \$4.50
 - Hurst. Hand Book for Architectural Surveyors and others engaged in building. Full bound. \$2.00
 - Jervis. Railroad Property. A Treatise on the Construction and Management of Railway Property. 12mo. \$2.00
 - Keene. A Hand Book of Practical Gauging. 8vo. Cloth. \$1.25

The above, or any of our Books, sent by mail, free of postage, at the publication prices. Our various catalogues of Books, covering all branches of INDUSTRIAL SCIENCE AND ART, sent free to any one who will furnish his address.

HENRY CAREY BAIRD & CO., Industrial Publishers, Booksellers, and Importers, 810 Walnut St., PHILADELPHIA.

WOOD WORKING MACHINERY.
PLANING, MATCHING, MOLDING, MORTISING, TENONING, CARVING, MACHINES, BAND & SCROLL SAWS, UNIVERSAL AND VARIETY WOOD WORKERS, J. A. FAY & CO., CINCINNATI, O. U. S. A.

WANTED,
A thorough, energetic, and practical mechanic, as Superintendent of Foundry and Machine Works employing forty hands on water wheels, engines, saw mill work, and repairs. State kind of work familiar with; pay, and address F. ROBERTS, Box 773, New York.

BEATTY'S PIANOS \$297.50.

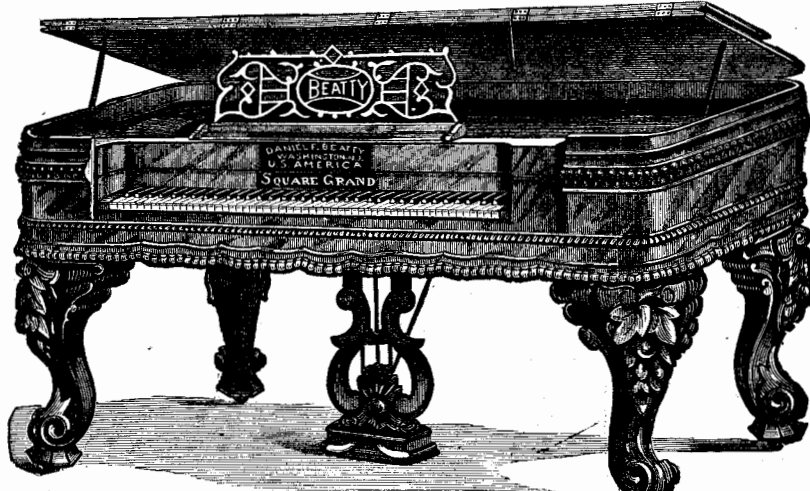

Beatty's Pianos, New Style No. 2023, magnificent rosewood case elegantly finished, 3 strings 7 1/2 Octave, full agraffe overstrung scale, all round corners, beautiful carved legs and lyre heavy serpentine and large fancy moulding round entire case, back finished same as front. Beatty's select full Iron Frame, French Grand Action, Capped Hammers. In fact every improvement which can in any way tend to the perfection of the instrument has been added.
My price for this instrument boxed & delivered on board cars at **\$297.50.**
Washington, N. J. with fine Piano Cover, Stool, Book, & Music, only \$297.50.
This Piano will be sent on test trial. Please send reference if you do not send money with order. Cash sent with order will be refunded and freight charges paid by me both ways if Piano is not just as represented in this Advertisement. Thousands in use. Send for list of name of persons who are using them at their own homes. Grand Square and Upright Pianos in great variety \$195 upwards. (See catalogue.) Every instrument fully warranted for six years.
14 Stops 4 Set Reeds only \$65. Pipe, Chapel and Parlor Organs \$65 upwards. Sent on trial. Those desiring to purchase are requested to visit my factory at Washington, New Jersey and select the instrument in person. Illustrated Catalogue and Advertiser, Holiday Edition, Sent Free.
Address or call on **DANIEL F. BEATTY, Washington New Jersey.**
Please Post above Advertisement in a Conspicuous Place.

SUPERIOR SUBSTITUTE FOR WOOD ENGRAVING.
J. C. MOSS, Pres. and Supl. M. A. MOSS, Treasurer. J. E. RAMSEY, Secretary. H. A. JACKSON, Asst. Sec.
MOSS ENGRAVING CO
INCORPORATED (MOSS'S NEW PROCESS.) APRIL 2, 1880
535 PEARL STREET, COR. ELM, NEW YORK.
LARGEST ESTABLISHMENT OF THE KIND IN THE WORLD.
ENGRAVINGS OF PORTRAITS, BUILDINGS, LANDSCAPES, MACHINERY, MAPS, ORNAMENTAL LETTERING AND GENERAL ILLUSTRATIONS FOR NEWSPAPERS, BOOKS, CATALOGUES, etc. Much cheaper than Wood Cuts. Mr. J. C. Moss, the inventor of the Moss Process of Photo-Engraving, in withdrawing from the Photo-Engraving Co., 67 Park Place, has retained for himself all improvements made and used by him in Photo-Engraving since May, 1872. Send green stamp for Illustrated Circular. Send copy for estimate. Please mention this paper.

THE STUDENT'S ILLUSTRATED GUIDE TO PRACTICAL DRAUGHTING. BY T. P. PEMBERTON. SENT ON RECEIPT OF PRICE, ONE DOLLAR. ADDRESS, T. P. PEMBERTON, 5 DEY ST., ROOM 13, NEW YORK.

NEW YORK BELTING AND PACKING COMP'Y.
The Oldest and Largest Manufacturers of the Original **SOLID VULCANITE EMERY WHEELS.**
All other kinds Imitations and Inferior. Our name is stamped in full upon all our standard BELTING, PACKING, and HOSE. Address NEW YORK BELTING AND PACKING CO., NEW YORK.
Emery Wheel. JOHN H. CHEEVER, Treas.

"BLAKE'S CHALLENGE" ROCK BREAKER.
Patented November 18, 1879.
For Macadam Road making, Ballasting of Railroads, Crushing Ores, use of Iron Furnaces, etc. Rapidly superseding our older styles of Blake Crusher on account of its superior strength, efficiency, and simplicity. Adopted by important Railway and Mining Corporations, Cities, and Towns. First Class Medal of Superiority awarded by American Institute.
BLAKE CRUSHER CO., Sole Makers, New Haven, Conn.

WORTHINGTON STEAM PUMPS
OF ALL SIZES AND FOR ALL PURPOSES.
HENRY R. WORTHINGTON,
239 BROADWAY, NEW YORK. 83 WATER ST., BOSTON. 709 MARKET ST., ST. LOUIS.

THE WALLACE DIAMOND CARBONS FOR ELECTRIC LIGHTS
MAN'F'D. FOR THE ELECTRICAL SUPPLY CO., 109 LIBERTY STREET, NEW YORK.

Wood-Working Machinery,
Such as Woodworth Planing, Tonguing, and Grooving Machines, Daniel's Planers, Richardson's Patent Improved Tenon Machines, Mortising, Moulding, and Re-Saw Machines, Eastman's Pat. Miter Machines, and Wood-Working Machinery generally. Manufactured by WITHERBY, RUGG & RICHARDSON, 25 Salisbury Street, Worcester, Mass. (Shop formerly occupied by R. BALL & CO.)

B. W. PAYNE & SONS, CORNING, N. Y.
ESTABLISHED 1840.
Patent Spark-Arresting Engines, mounted and on skids. Vertical Engines with wro't boilers. Eureka Safety powers with Sectional boilers—can't be exploded. All with Automatic Cut-Offs. From \$150 to \$2,000. Send for Circular. State where you saw this.

AMERICAN MERCHANTS,
Makers of Wood and Iron Working Machinery, Agricultural Implements, Railway Equipments, and manufacturers generally, are invited to forward catalogues, with best export prices and discounts, for E. O. B., New York, Boston, or Philadelphia, to W. WILLIAMS & CO., No. 1 The Exchange, Collins St. West, Melbourne, Victoria, Australia.

SHEPARD'S CELEBRATED \$50 Screw Cutting Foot Lathe.
Foot and Power Lathes, Drill Presses, Scrolls, Circular and Band Saws, Saw Attachments, Chucks, Mandrels, Twist Drills, Dogs, Calipers, etc. Send for catalogue of outfits for amateurs or artisans.
H. I. SHEPARD & CO., 331, 333, 335, & 337 West Front Street, Cincinnati, Ohio.

AGENTS WANTED EVERYWHERE to sell the best Family Knitting Machine ever invented. Will knit a pair of stockings, with HEEL and TOE complete, in 20 minutes. It will also knit a great variety of fancy work, for which there is always a ready market. Send for circular and terms to the **Twombly Knitting Machine Co., 409 Washington St., Boston, Mass.**

The only genuine Geiser.
Peerless Farm Engine.
THE GEISER REGULATING SEPARATOR AND THE PEERLESS FARM AND DOMESTIC STEAM ENGINES MADE BY THE GEISER MFG. CO. WAYNEBORO, N. J.

JOHN R. WHITLEY & CO.
European Representatives of American Houses, with First-class Agents in the principal industrial and agricultural centers and cities in Europe. London, 7 Poultry, E. C. Paris, 8 Place Vendôme. Terms on application. J. R. W. & Co. purchase Paris goods on commission at shippers' discounts.

ROOTS' NEW IRON BLOWER.

POSITIVE BLAST. IRON REVOLVERS, PERFECTLY BALANCED IS SIMPLER, AND HAS FEWER PARTS THAN ANY OTHER BLOWER.
P. H. & F. M. ROOTS, Manuf'rs, CONNERSVILLE, IND.
S. S. TOWNSEND, Gen. Agt., { 6 Cortlandt St., } NEW YORK
WM. COOKE, Selling Agt., { 8 Dey Street, }
JAS. BEGGS & CO., Selling Agts., { 8 Dey Street, }

FIRE BRICK TILE AND CLAY RETORTS ALL SHAPES. BORNGNER & O'BRIEN, 23 1/2 ST. ABOVE RACE, PHILADELPHIA.

ERICSSON'S NEW MOTOR. ERICSSON'S New Caloric Pumping Engine,
FOR DWELLINGS AND COUNTRY SEATS. Simplest, cheapest, and most economical pumping engine for domestic purposes. Any servant girl can operate. Absolutely safe. Send for circulars and price lists.

DELAMATER IRON WORKS
C. H. DELAMATER & CO., Proprietors, No. 10 Cortlandt Street, New York, N. Y.

Bookwalter Engine.
Compact. Substantial. Economical, and easily managed; guaranteed to work well and give full power claimed. Engine and boiler complete, including Governor, Pump, etc., at the low price of
3 HORSE POWER.....\$40 00
4 1/2 ".....25 00
6 ".....37 00
Put on cars at Springfield, O. JAMES LEFFEL & CO., Springfield, Ohio. or 110 Liberty St., New York.

MACHINISTS' TOOLS.
NEW AND IMPROVED PATTERNS. Send for new illustrated catalogue.
Lathes, Planers, Drills, &c. NEW HAVEN MANUFACTURING CO., New Haven, Conn.

Punch and Shears
of beautiful design, of great strength and capacity, and thoroughly reliable, address
Lambertville Iron Works, LAMBERTVILLE, N. J.

WHEAT Dealers make Money with W. T. SOULE & CO., 130 La Salle Street, Chicago, Ill. Write for particulars.

TIGHT & SLACK BARREL MACHINERY
A SPECIALTY OF JOHN GREENWOOD & CO., ROCHESTER N. Y.

The George Place Machinery Agency
Machinery of Every Description, 121 Chambers and 103 Reade Streets, New York.

SPARE THE CROTON AND SAVE THE COST. Driven or Tube Wells
furnished to large consumers of Croton and Ridgewood Water. WM. D. ANDREWS & BRO., 235 Broadway, N. Y., who control the patent for Green's American Driven Well.

50 Elegant Cards, 50 styles, with name, 10c. 40 Transparent, 10c. Stamps taken. PEARL CO., Brockport, N. Y.

PONY PLANER
Will plane 6 inches thick, and as thin as 1/4 inch, and in quantity from 3,000 to 18,000 feet in ten hours. We build four sizes, 16, 20, 24, and 30 inch, either with one or two roller feed; also, Eureka Band Saw, Upright Shaping and Variety Moulding Machines. For particulars, address FRANK & CO., Buffalo, N. Y.

CIGAR BOX LUMBER.
SPECIAL PRICES to all parties ordering 20,000 FEET and upwards. Being Sole Manufacturers of the celebrated perfectly smooth and thoroughly seasoned CUT AND PRESS DRIED LUMBER, we can offer to all manufacturers extra inducements in line of Cigar Box Cedar Boards and Veneers, Poplar, Sycamore, Butternut, and Mahogany. Also in Panel Woods and Brush Stock. Our Cedar Veneers applied to Poplar, is much preferred to imitation Cedar. Full line Foreign and Domestic Woods in Logs, Plank, Boards, and Veneers. Send for Catalogue and Price List. GEO. W. READ & CO., 186 to 200 Lewis Street, New York.

SWEEPSTAKES, WITH THE ELLIS Patent Journal Box. The best Planer and Mather ever made. Planing 30 in. wide, 6 in. thick, weight 2,200 lbs., \$300; planing 24 in. wide, 6 in. thick, weight 2,600 lbs., \$350. Beading, Arbor and Lead, extra, \$30. Sash, door, and blind machinery a specialty. Send for descriptive catalogue to Rowley & Hermance, Williamsport, Pa.

DR. SCOTT'S ELECTRIC HAIR BRUSH.

A REMARKABLE INVENTION,

Which has won its way to Royal favor in England, been cordially indorsed by the Prince and Princess of Wales, and written upon by the Rt. Hon. W. E. Gladstone, is now brought to the notice of the American public. It cures by natural means, will always do good, never harm, and is a remedy lasting for many years. It should be used daily in place of the ordinary Hair Brush. The Brush Handle is made of a new odorless composition resembling ebony; a combination of substances PRODUCING A PERMANENT ELECTRIC VOLTAIC CURRENT WHICH ACTS IMMEDIATELY UPON THE HAIR GLANDS AND FOLLICLES. Its power can always be tested by a silver compass which accompanies each Brush.

IT IS WARRANTED TO
CURE NERVOUS HEADACHE IN 5 MINUTES!!
CURE BILIOUS HEADACHE IN 5 MINUTES!!
CURE NEURALGIA IN 5 MINUTES!!
PREVENT FALLING HAIR AND BALDNESS!!
CURE DANDRUFF & DISEASES OF THE SCALP!!
PROMPTLY ARRESTS PREMATURE GRAYNESS!!
MAKES THE HAIR GROW LONG & GLOSSY!!
IMMEDIATELY SOOTHES THE WEARY BRAIN!!
MONEY RETURNED IF NOT AS REPRESENTED.

IT RARELY FAILS TO PRODUCE A RAPID GROWTH OF HAIR ON BALD HEADS, WHERE THE GLANDS and FOLLICLES ARE NOT TOTALLY DESTROYED.

Proprietors: The Pall Mall Electric Association of London.
 New York Branch: 842¹/₂ Broadway.

[From the Mayor of Saratoga.] August 12, 1880.

"I cheerfully testify to the merits of Dr. Scott's Electric Hair Brush. It cures my headaches within a few minutes. I am so pleased with it I purchased another for my wife. It is an excellent Hair Brush, well worth the price, aside from its curative powers."
 JAS. B. CHAPMAN.

218 Fulton Street, New York, August 31, 1880.

"I would Not take \$1,000 for my Brush"

If I could not replace it."
 Mr. Smith is a gentleman well known in this City as a Law Publisher, and also as a Director in several Public Institutions of New York.

DR. GEO. A. SCOTT—Dear Sir: Permit me to add the testimony of my wife to that of the many others who have been benefited by the use of your Electric Brush. She has for years been a sufferer from Neuralgia in an acute form, but since I obtained for her one of your Brushes, she has experienced entire relief. Please accept her sincere thanks.
 HENRY BARTLETT.
 Round Lake Camp-Meeting Grounds, Saratoga Co., N. Y., June 8, 1880.

"Your Brush is certainly a remarkable cure. I am highly pleased with it. Its effect is most wonderful, and you may be sure I shall recommend it heartily among my friends. It is also a splendid Hair Brush, well worth the money, and will last me for years."
 Rev. J. D. ROGERS, Superintendent.
 Over 7,000 similar Testimonials can be seen at our office.

A BEAUTIFUL BRUSH, LASTING FOR YEARS.

We will send it, postpaid, on receipt of \$3.00; or by Express C. O. D. at your expense, with privilege of opening and examining. Or request your nearest Druggist or Fancy Store to obtain one for you. FROM US. MONEY RETURNED IF NOT AS REPRESENTED.

As soon as you receive the Brush, if not well satisfied with your bargain, write us, and we will return the money. What can be fairer? This paper will not knowingly publish any humbug, and I have placed a Brush in the hands of Mayor Cooper and Postmaster James of New York, as a guarantee of my good faith.

Remittances should be made payable to GEO. A. SCOTT, 842¹/₂ Broadway, New York. Agents wanted in every town. They can be made in checks, drafts, post office orders, or currency. Inclose 10 cents for registration, and we guarantee safe delivery of Brush.

H.W. JOHNS' ASBESTOS

LIQUID PAINTS, ROOFING, BOILER COVERINGS, Steam Packing, Sheathings Fireproof Coatings, Cements, SEND FOR ILLUSTRATED CATALOGUE, AND PRICE LIST.
 H. W. JOHNS M'FG CO., 87 MAIDEN LANE, N. Y.

HARTFORD STEAM BOILER Inspection & Insurance COMPANY.

W. B. FRANKLIN, V. Pres't. J. M. ALLEN, Pres't.
 J. B. PIERCE, Sec'y.

THE NEW PULSOMETER

Is more economical in points of original cost, expense for repairs and running expenses, than any other Steam Pump in the World.

Simple and compact, with no machinery whatever to oil or get out of order, it stands at the head of all means of elevating water or other liquids by steam. It needs no skilled labor to look after it. Send for book giving full description, reduced prices and many letters of commendation from leading manufacturers and others throughout the country who are using them.

PULSOMETER STEAM PUMP CO., Sole Owners of Hall's Patents in the U. S., 131,515 to 131,543, both inclusive, and the NEW PULSOMETER, Office, No. 83 John St., P. O. Box No. 1533, New York City.

WM. A. HARRIS. PROVIDENCE, R. I. (PARK STREET), Six minutes walk West from station. Original and Only builder of the HARRIS-CORLISS ENGINE With Harris' Patented Improvements, from 10 to 1,000 H. P.

COLUMBIA BICYCLE.

The Bicycle has proved itself to be a permanent, practical road vehicle, and the number in daily use is rapidly increasing. Professional and business men, seekers after health or pleasure, all join in bearing witness to its merits. Send 3 cent stamp for catalogue with price list and full information.
 THE POPE M'FG CO., 89 Summer Street, Boston, Mass.

EMERY WHEELS and GRINDING MACHINES.



THE TANITE CO.,

Stroudsburg, Monroe County, Pa.

Orders may be directed to us at any of the following addresses, at each of which we carry a stock:

- London, Eng., 9 St. Andrews St., Holborn Viaduct, E. C.
- Liverpool, Eng., 42 The Temple, Dale St.
- Sydney, N. S. W., 11 Pitt St.
- New York, 14 Dey Street.
- Philadelphia, 11 North Sixth Street.
- Chicago, 152 and 154 Lake St.
- St. Louis, 209 North Third St.
- St. Louis, 811 to 819 North Second St.
- Cincinnati, 212 West Second St.
- Indianapolis, Corner Maryland and Delaware Sts.
- Louisville, 427 West Main St.
- New Orleans, 26 Union St.
- San Francisco, 2 and 4 California St.

The Asbestos Packing Co.,

Miners and Manufacturers of Asbestos, BOSTON, MASS., OFFER FOR SALE: PATENTED ASBESTOS ROPE PACKING, " " LOOSE " " " JOURNAL " " " WICK " " " MILL BOARD, " " SHEATHING PAPER, " " FLOORING FELT, " " CLOTH.

OPEN BACK PRESSES, STILES & PARKER PRESS CO., Middletown, Ct.

THE MACKINNON PEN OR FLUID PENCIL.



Particulars mailed Free. MACKINNON PEN CO., 200 Broadway, near Fulton St., N. Y.

Mill Stones and Corn Mills.

We make Burr Millstones, Portable Mills, Smut Machines, Packers, Mill Picks, Water Wheels, Pulleys, and Gearing specially adapted to Flour Mills. Send for catalogue.
 J. T. NOYE & SONS, Buffalo, N. Y.

BOILER COVERINGS.

Plastic Cement and Hair Felt, with or without the Patent "AIR SPACE" Method. ASBESTOS MATERIALS. Made from pure Italian Asbestos, in fiber, mill board, and round packing. THE CHALMERS-SPENCE CO., 40 John Street, and Foot of E. 9th Street, New York.

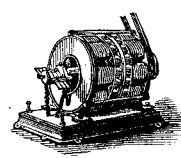

ELECTRIC LIGHT.

DYNAMO-ELECTRIC MACHINE, No. 1. CANDLE POWER, 2,000. HORSE POWER, 1 1-2. PRICE \$200, WITH COUNTERSHAFT. LAMP, \$50. THE FULLER ELECTRICAL CO., 33 Nassau St., New York.

THE New York Ice Machine Company, 21 Courtland St., New York, Rooms 54, 55.

LOW PRESSURE BINARY ABSORPTION SYSTEM.

Machines Making ICE AND COLD AIR.

Low Pressure when running. No pressure at rest. Machines guaranteed by C. H. Delamater & Co.

THE BAKER BLOWER.

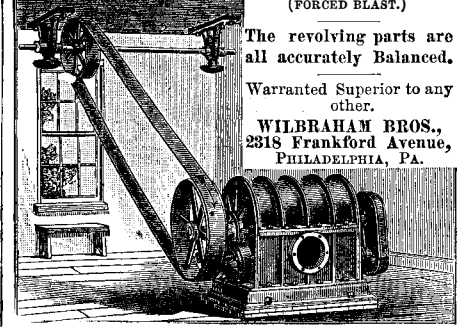

(FORCED BLAST.) The revolving parts are all accurately Balanced.

Warranted Superior to any other.

WILBRAHAM BROS., 2318 Frankford Avenue, PHILADELPHIA, PA.

AGENTS CAN MAKE \$5,000.00

THE MANUFACTURERS' CABINET.

By employing Agents for 500 Manufacturers. By manufacturing rapid selling articles. By getting, through means of the Cabinet, the best agencies in the world.
 Address J. B. CHAPMAN, 72 WEST ST., MADISON, IND.

WATSON'S NON CHANGEABLE GAP LATHES HAS THE BEST WORK JAMES WATSON GREAT FACILITIES FOR LARGE OR MEDIUM SIZES WORK. 1508 S. FRONT ST. PHILA.

T. NEW'S Prepared ROOFING.

For steep or flat roofs. Applied by ordinary workmen at one-third the cost of the Circulars and samples free. Agents Wanted. T. NEW, 32 John Street, New York. BARRETT, ARNOLD & KIMBALL, Chicago, Western Agts.

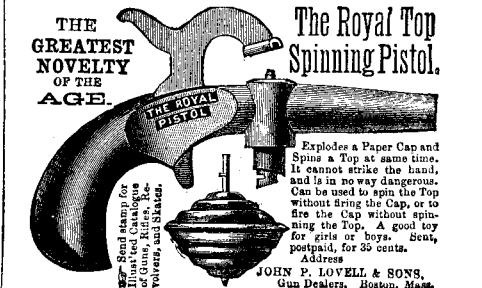

THE GREATEST NOVELTY OF THE AGE. The Royal Top Spinning Pistol. Explodes a Paper Cap and Spins a Top at same time. It cannot strike the hand, and is in no way dangerous. Can be used to spin the Top without firing the Cap, or to fire the Cap without spinning the Top. A good toy for girls or boys. Sent, postpaid, for 35 cents. Address JOHN P. LOVELL & SONS, Gun Dealers, Boston, Mass.

BROWN'S PAT. SPLIT PULLEYS Shafts, Hangers, PULLEYS

At low prices. Largest assortment. A. & F. BROWN, 57, 59, & 61 Lewis St., New York.

BOGARDUS' PATENT UNIVERSAL ECCENTRIC MILLS—For grinding Bones, Ores, Sand, Old Crucibles, Fire Clay, Guanoo, Oil Cake, Feed, Corn, Corn and Cob, Tobacco, Snuff, Sugar, Salts, Roots, Spices, Coffee, Coconut, Flaxseed, Asbestos, Mica, etc., and whatever cannot be ground by other mills. Also for Paints, Printers' Inks, Paste Blacking, etc.

JOHN W. THOMSON, successor to JAMES BOGARDUS, corner of White and Elm Sts., New York.

The Oldest YANKEE NOTION HOUSE in the World.

HOWARD BROTHERS & READ,

Successors to HOWARD, SANGER & CO., OWNERS OF THE HOWARD MANUFACTURING CO., MANUFACTURE AND INTRODUCE PATENTED NOVELTIES.

THE ONLY Real Pocket Scale IN THE MARKET.

MADE OF METAL, Heavily Nickel Plated, COMPACT, STRONG, DURABLE.

Can be carried in the Vest Pocket. Each one warranted absolutely accurate. Weighs up to 8 lbs.

PRICE 25 CENTS. Sample by mail on receipt of price. A liberal discount to the trade.

No. 1—"Post Office," weighs to 8 ozs.
 " 2—"Pocket," " 8 lbs.
 " 3—"Household," " 15 lbs.

HOWARD MANUFACTURING CO., BOX 2295, NEW YORK.

THE "Scientific American" is printed with CHAS. ENEU JOHNSON & CO.'S INK. Tenth and Lombard Sts., Philadelphia, and 50 Gold St. New York.