

SCIENTIFIC AMERICAN

A WEEKLY JOURNAL OF PRACTICAL INFORMATION, ART, SCIENCE, MECHANICS, CHEMISTRY, AND MANUFACTURES.

Vol. XL.—No. 13.
[NEW SERIES.]

NEW YORK, MARCH 29, 1879.

[\$3.20 per Annum.
[POSTAGE PREPAID.]

A NEW STEAM TILLER.

Steam is now made to perform almost everything in the way of heavy labor, to the saving of muscle and energy that may be more profitably employed; and since inventive genius has devised means of governing steam with absolute accuracy, there seems to be no limit to its economical application.

A recent invention in steam engineering, which exhibits in a marked degree the controllability and adaptability of steam, is Mr. Herbert Wadsworth's steam tiller, an engraving of which we present herewith.

This machine (Fig. 1) is provided with a steam cylinder, similar to the cylinder of a steam engine, containing a piston, the rod of which is attached to a crosshead, A, that slides on ways, B, secured to the bed supporting the cylinder.

The tiller, D, as it is carried to starboard or port, slides through a socket, E, pivoted to the crosshead.

The motion of the rudder is communicated to the steam cut-off by means of the shaft, C, crank, J, rod, K, crank, I, and the hollow valve spindle. When the tiller is amidships the valve handle, H, is at right angles to the cylinder, and parallel to the tiller. By moving the lever, H, to right or left, steam is admitted to one end or the other of the cylinder, which, acting on the tiller through the piston, piston rod, and crosshead, moves the rudder; and when the rudder reaches the desired position the cut-off will have been moved the amount necessary to prevent further entrance

of steam. When the rudder is influenced by the waves or by the expansion or contraction of steam, the cut-off alters its position in relation to the valve and automatically arranges the steam passages so that the piston is returned to its proper position. The details of the cut-off are shown in Fig. 2; the valve, G, which covers the cut-off, F, acts like a four way cock. The spindle of the cut-off, F, is connected with the lever, I, and is moved by the rudder, as already described. By enlarging or gradually narrowing the ends of

the steam ports great rigidity or elasticity may be given to the hold of this engine, according to the requirements of the particular vessel.

Few and simple as are the parts of this machine it is possible, by balancing the valves and suiting the diameter of the cylinder to the work to be performed, to overcome great resistances with a slight effort. The inventor says that this system of valves is considered by experts to be novel and very valuable.

In Fig. 3 is shown a pattern of a slide valve suited to special purposes. Its working is essentially the same as that of the valve already described. The ports are set side by side, parallel with the sides of the valve. The supply port is in the middle, the other ports lead to opposite ends of the cylinder.

In Fig. 4 is shown another application of the controlling valve and cut-off described above. Two oscillating steam cylinders are employed in working the rudder. They are placed on opposite sides of the chest, A, and are supplied with steam through the controlling valve, B. The piston rods of the two cylinders are connected with cranks placed on opposite ends of the shaft, C, at right angles to each other. Upon this shaft, half-way between the pillow blocks which support it, there is a worm which engages a toothed sector, D, on the rudder-post, E. To an extension of the rudder-post is secured an arm, F, which is connected with the arm, G, of the controlling valve. By shifting the lever, H, the supply of steam to the two cylinders may be in

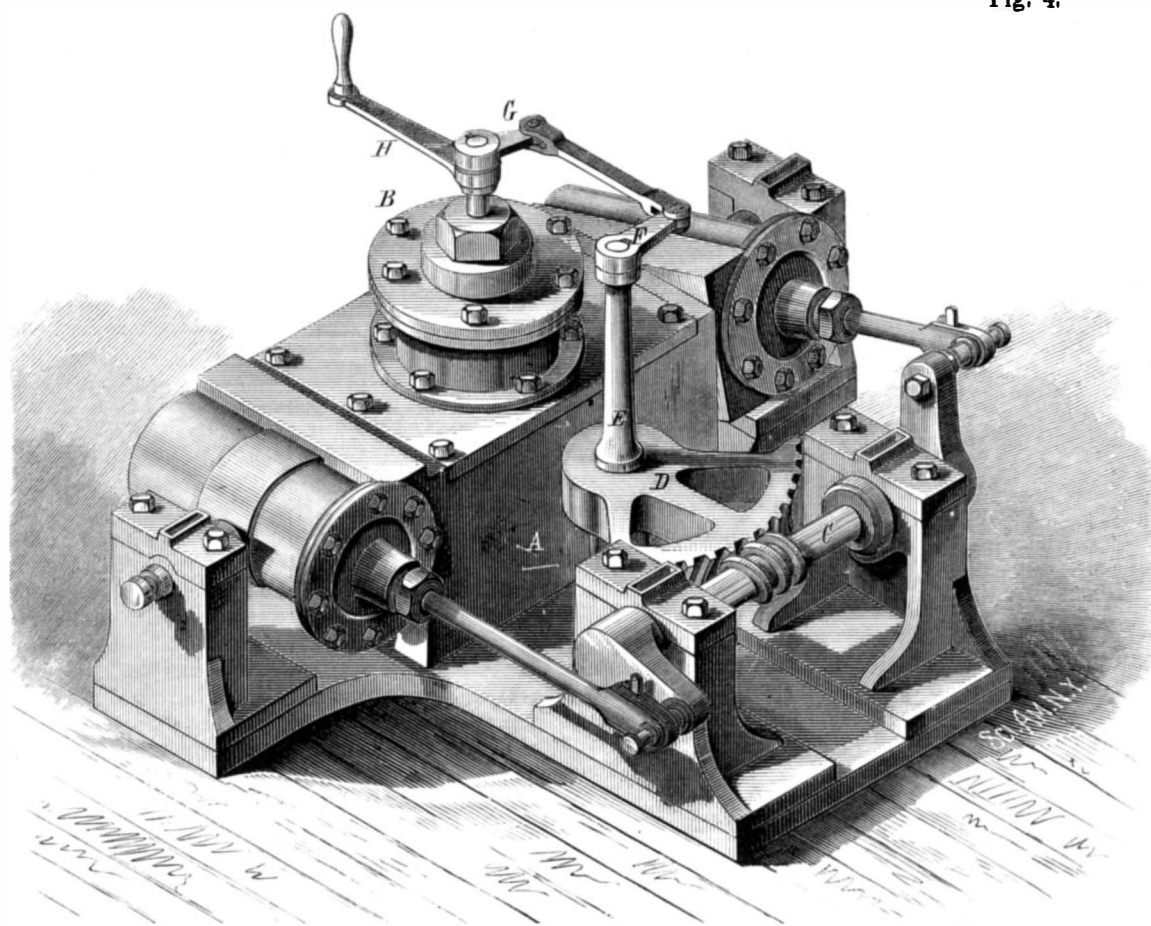

Fig. 4.

Fig. 1

Fig. 2

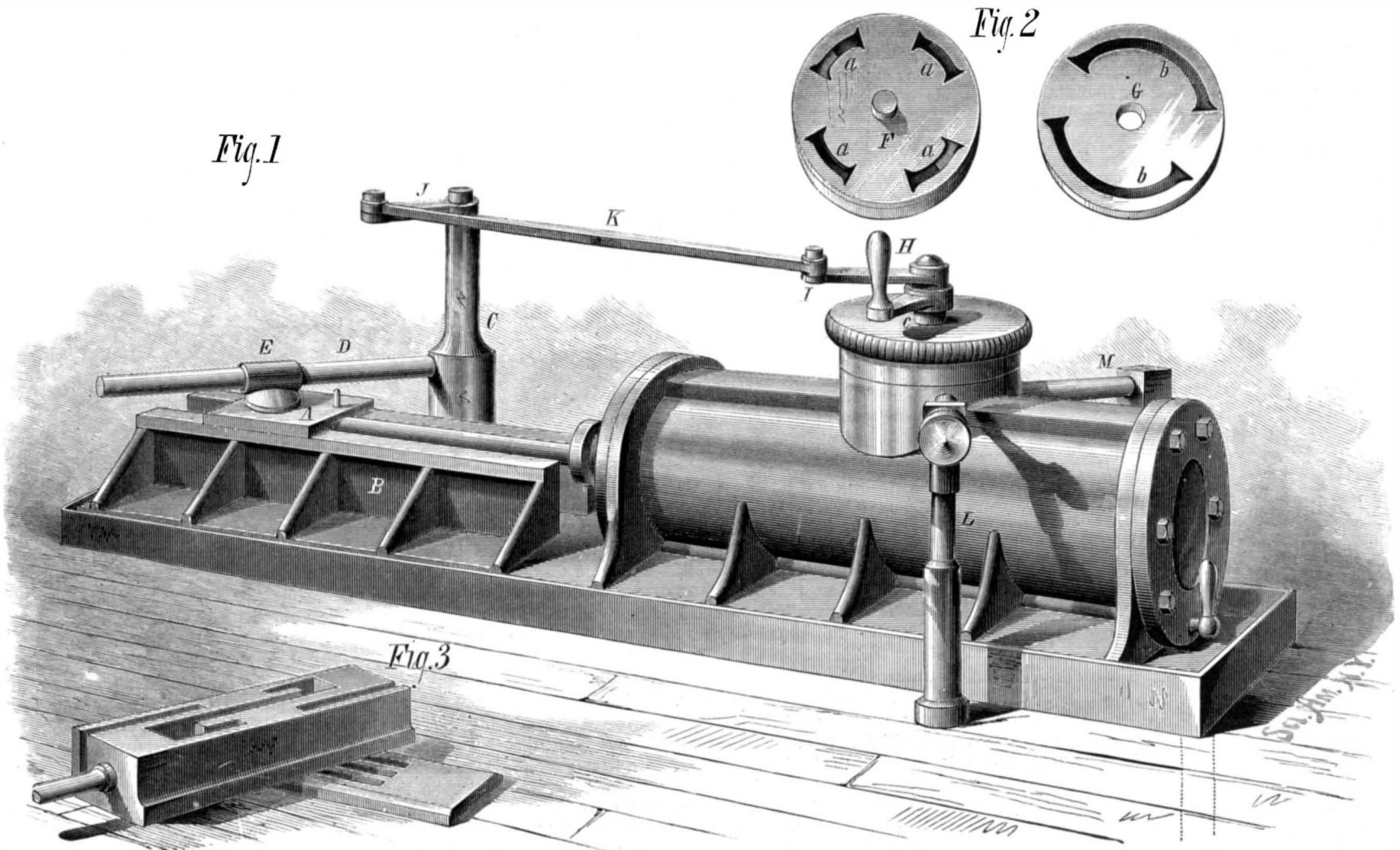

Fig. 3

WADSWORTH'S NEW STEAM TILLER FOR VESSELS.

creased or diminished, or its direction may be changed, so that the engines will be reversed or stopped. This engine is remarkable for its simplicity. The cylinders may be detached and changed if required, one size of bed answering for three different sizes of cylinder, which may vary only in diameter, the stroke being the same, so that the castings for engines of different power are the same except in the matter of the cylinders and pistons, and all the parts are interchangeable—a feature of modern engine building that cannot be too highly valued.

Further information may be obtained from Herbert Wadsworth, 26 Merchants' Bank Building, 28 State street, Boston, Mass.

Scientific American.

ESTABLISHED 1845.

MUNN & CO., Editors and Proprietors.

PUBLISHED WEEKLY AT

NO. 37 PARK ROW, NEW YORK.

A. D. MUNN.

A. E. BEACH.

TERMS FOR THE SCIENTIFIC AMERICAN.

One copy, one year, postage included. \$3 20
One copy, six months, postage included 1 60

Clubs.—One extra copy of THE SCIENTIFIC AMERICAN will be supplied gratis for every club of five subscribers at \$3.20 each; additional copies at same proportionate rate. Postage prepaid.

Single copies of any desired number of the SUPPLEMENT sent to one address on receipt of 10 cents. Remit by postal order. Address MUNN & CO., 37 Park Row, New York.

The Scientific American Supplement

is a distinct paper from THE SCIENTIFIC AMERICAN. THE SUPPLEMENT is issued weekly. Every number contains 16 octavo pages, with handsome cover, uniform in size with SCIENTIFIC AMERICAN. Terms of subscription for SUPPLEMENT, \$5.00 a year, postage paid, to subscribers. Single copies 10 cents. Sold by all news dealers throughout the country.

Combined Rates.—THE SCIENTIFIC AMERICAN and SUPPLEMENT will be sent for one year, postage free, on receipt of seven dollars. Both papers to one address or different addresses, as desired. The safest way to remit is by draft, postal order, or registered letter. Address MUNN & CO., 37 Park Row, N. Y.

Scientific American Export Edition.

The SCIENTIFIC AMERICAN Export Edition is a large and splendid periodical, issued once a month. Each number contains about one hundred large quarto pages, profusely illustrated, embracing: (1.) Most of the plates and pages of the four preceding weekly issues of THE SCIENTIFIC AMERICAN, with its splendid engravings and valuable information; (2.) Commercial, trade, and manufacturing announcements of leading houses. Terms for Export Edition, \$5.00 a year, sent prepaid to any part of the world. Single copies 50 cents. Manufacturers and others who desire to secure foreign trade may have large, and handsomely displayed announcements published in this edition at a very moderate cost. The SCIENTIFIC AMERICAN Export Edition has a large guaranteed circulation in all commercial places throughout the world. Address MUNN & CO., 37 Park Row, New York.

VOL. XL., No. 13. [NEW SERIES.] Thirty-fourth Year.

NEW YORK, SATURDAY, MARCH 29, 1879.

Contents.

(Illustrated articles are marked with an asterisk.)

Table listing various articles such as Africa crossed again, Aluminum, Barometer, aneroid, Bolt, door, improved, Bread, snow-raised, Buffalo, domestication of the, Carpet beetle, remedy for the, Chimney flues, Clocks, pneumatic, Cooper, Peter, as an inventor, Crusher, ore, novel, Electricity, statical, phenom. in, Flour, banana, Furnace, imp., for burn, oil, Hardware, English & American, Ice cave of Decorah, Iowa, Inventions, new agricultural, Iron, advance in, Light, alio-carbon, Magnetism, curious facts in, Motor, Gary, the, Natural science, charms of, Neutral line, Gary's, Notes and queries, Patent laws, Patents, American, recent, Pen, stencil, new, People, a strange, Phosphorescence, Plants, protected by insects, Pleuro-pneumonia, Railway, Vesuvius, Reading and eyesight, Reading, taste for, Regulator, engine, novel, Spain a field for machinery, Sponges, glass, Steamship, ocean, large, Table, ironing, new, Telegraph, writing, Telegraph, writing, Cowper's, Telegraphy, ocean, progress of, Tiller, steam, new, Tree, pottery, Vase, Greek, ancient.

TABLE OF CONTENTS OF THE SCIENTIFIC AMERICAN SUPPLEMENT No. 169.

For the Week ending March 29, 1879. Price 10 cents. For sale by all newsdealers.

Table listing supplement articles such as I. ENGINEERING AND MECHANICS.—The Herreshoff Torpedo Boat, recently built at Bristol, R. I., for the British Government. The novelties in the placing of the screw, etc. The Peculiar Boiler. 4 figures.—Improved Hopper Steam Dredger. 2 figures.—The St. Gothard Tunnel.—The Beacon Tower of Lavezzi. 3 figures. II. ARCHITECTURE.—Bath Abbey Church. Full page illustration. III. TECHNOLOGY.—The Acheson Stone Cutting Machine. 1 engraving.—The Mines of the World.—Shoemakers' Wax.—Gruber's New Method of Germination. 1 engraving.—Improved Process for Treating Wood, etc., for Paper Manufacture.—Bronzing Plaster of Paris Casts.—Sal Soda for Unhairing Hides and Skins.—Sieburger's Paste.—To Tan Lace Leather with Softsoap.—Practical Dyeing Recipes.—Blue white zephyr, Scotch blue on worsted, Scotch green on worsted, jacquelineux on worsted, drab on worsted, gold on venetian carpet yarn, red brown slubbing, scarlet braid, slate braid, light drab on cotton, blue on cotton, brown on cotton, chrome orange on cotton carpet yarn, black on common mixed carpet yarn for filling, black on cotton and wool mixed yarn.—Damar Varnish for Negatives.—To Make Vignettes by Means of Gelatin-bromate.—Resorcin Colors.—Phosphate Soaps.—Substitution of Different Metals in Ultramarine Colors.—A Harmless Green for Paper Hangings.—Siegwart's Bath for Etching Glass.—Composition of French Bronzes.—A New Enemy to the Tea Plant.—The Bradford Oil Sand. IV. CHEMISTRY AND METALLURGY.—Apparatus for Titration, 1 figure.—Palladium.—Hæmocyannin.—Test for Alcohol in Etheral Oils and Chloroform.—Reaction of Tartaric and Citric Acid.—A Peculiar Observation.—Insolubility of Iodate of Lead.—Mode of Preventing the Contamination of Water with Lead.—Separating Phosphorus from Iron and Steel.—Production of Alcohol without Fermentation. V. ELECTRICITY, LIGHT, HEAT, ETC.—Some Facts in regard to Telescopic and Stereoscopic Vision.—The Centenary of the Birth of Sir Humphry Davy. His boyish days. His first chemical experiments. His first lecture at the Royal Institution. A very entertaining biographical sketch.—Light and Heat in Gas Flames.—Nickel Needles for Compasses.—The Nature of the Elements.—A New Compound Prism for Direct Vision Spectroscopes. VI. MEDICINE AND HYGIENE.—Filaria in the Eye. By CHAS. S. TUNBULL, M.D.—The Species of Tapeworm now Prevalent.—Nitrous Oxide under Pressure. VII. NATURAL HISTORY, GEOLOGY, ETC.—A Gigantic American Deep-sea Crustacean. 1 engraving.—Glaciers in the United States.—The Touloume Cave.—Achealogical Explorations in Tennessee. By F. W. PUTNAM. 6 figures.—Memorably Cold Winters.—Life at Timber Line. By Professor C. E. ROBINSON, Summit, Colorado.—The Walled Lake in Iowa. VIII. ASTRONOMY.—Is the Moon Inhabited? By CAMILLE FLAMMARION. The various opinions that have been held in regard to the moon. The best we can do with our telescopes. The means we possess for judging of the condition of the moon. Recent changes on the moon. Photographs of the moon and their defects. Facts that have been observed by the persevering eyes of astronomers.

HOW OUR PATENT LAWS PROMOTE AND IMPROVE AMERICAN INDUSTRIES.

On another page we print in full a most suggestive paper recently read before the Manchester (Eng.) Scientific and Mechanical Society, by Mr. Frederick Smith, a prominent builder of that city, contrasting the qualities, styles, and prices of American and English builders' hardware—a paper which the Ironmonger pronounces one of the most serious indictments yet preferred against British workmanship in that department.

The field covered by the paper—the supplying of house builders' hardware—embraces a multitude of conveniences, but no real necessities. Why is it that America has been prolific in novel devices and clever improvements in this department of manufacture as in so many others, while England has gone on stolidly copying ancient forms, changing only to cheapen by the introduction of poor material and sham construction? Mr. Smith mentions several reasons that English manufacturers have given him for the state of things he, as an Englishman, so greatly deplors; but evidently he is not satisfied with any of them, and very justly; for none of them touches the real cause—the radically different attitude of the public mind toward inventions, characteristic of the two countries.

In England the user of household inconveniences accepts them as matters of fact; or if he grumbles at them he never thinks of trying to change them. It is not his business; and if he should devise an improvement, ten to one he could not get it made. To patent it is practically out of the question, for if it were not condemned off-hand as trivial, the patent fees would make it cost more than it was likely to be worth. The mechanic who makes such things is trained to work to pattern, and not waste his time on experiments. Besides, if he should make a clever invention he would not be able to raise the necessary fees for a patent, or to get any one to help him thereto. The manufacturer "makes what his customers call for." Why should he spend his money and spoil his plant to introduce improvements? So things go, until some pestilent Yankees flood the markets with better articles at a lower price; and British consumers suddenly discover that they want something that the native manufacturer cannot make. The need was there; but invention did not follow. How happened it that the American manufacturer did not pursue the same uninventive course? What produced the radically different attitude of the American mind toward newfangled notions out of which inventions proceeded and flourished?

No doubt several causes have been at work: freedom of thought and action; popular education; a blending of races; and the tide of adventurous spirits naturally resorting to a new and free land. These have had their influence undoubtedly; but all these have existed, more or less completely, in other new lands, without that outburst of creative energy which has made America the nursery of inventions, great and small. The determining cause, the one condition that prevailed here and not elsewhere, was the circumstance that almost from the start new ideas were given a market value in this country. Unlike all others, the American patent law directly encouraged independent thinking in all classes. The fees were low and the protection offered fairly good. Men soon found that it paid to invent; that one of the surest roads to competency was a patented improvement on something of general use. If a household utensil or appliance went wrong or worked badly, every user was directly interested in devising something better; and, more than that, he was interested in making his invention known and in securing its adoption. The workman at his bench had an ever-present inducement to contrive something at once cheaper and better than the article he was hired to make. He could patent his improvement, or the wholly original device he might hit upon, for a few dollars; and his patent would count as capital. It would make him his own master, possibly bring him a fortune. The manufacturer could not rest contented with the thing he set out to make, for the meanest hired man in his employ might suddenly become a competitor. He must be constantly alert for possible improvements, or his rivals would get ahead of him. The result is a nation of inventors, at whose hands the newest of lands has leaped to the leadership in the arts, almost at a bound.

There is talk of changing all this; of emulating the conservative spirit of the Old World; of putting inventors under bonds; of stopping the rush of industrial improvement—to enable a few short-sighted yet grasping corporations to get along without paying license fees for such inventions as they happen to approve of. They profess to want inventors to go on making improvements. They are willing to ascribe all honor to the successful inventor; but they are determined not to pay him for his work. Still more they are determined to change the attitude of the public mind toward inventors and inventions, if such a change can be wrought by plausible misrepresentations. The fact that they were able to inveigle one branch of the American Congress into assenting to their unjust and mischievous scheme is one of the anomalies of our recent history. It should be taken as a timely warning of impending danger to all the industrial interests of the country. It is outrageous that the inventors of the land, after having raised their country to the first rank among industrial nations, should have to defend their constitutional rights against Congressional invasion; but the fact exists; and the defense should be made a matter of personal interest and effort not only by every inventor and manufacturer, but by every honest citizen.

PLEURO-PNEUMONIA.

The cattle plague, which is creating so much anxiety throughout the Eastern States, is a contagious fever, affecting cows chiefly, characterized by extensive exudations into the respiratory organs, and attended by a low typhus inflammation of the lungs, pleura, and bronchia. It has prevailed in Europe for ages, at times developing into wide-spread scourges, causing incalculable loss. It was imported into England in 1839, and again three years later; and it was estimated that within twenty-five years thereafter the losses by deaths alone in England had amounted to \$450,000,000. In 1858 the disease was carried to Australia by an English cow, and, spreading to the cattle ranges, almost depopulated them.

In 1843 an infected Dutch cow brought the disease to Brooklyn, where it has since lingered, slowly spreading among the cattle in Kings and Queens counties. In 1847 several head of infected English cattle were imported into New Jersey, and, spreading among a herd of valuable cattle, made it necessary for them all to be slaughtered, the only certain method of stamping out the disease. In 1859 four infected cows were imported into Massachusetts from Holland; the plague spread rapidly, and was stamped out only by persistent effort, the State paying for over 1,000 slaughtered cattle. Since 1867 the disease has not been known there. Meantime the pest had invaded Eastern Pennsylvania, Delaware, and Maryland, where it has since prevailed in isolated localities. The absence of large herds of moving cattle in these districts, except for speedy slaughter, has prevented the disease from developing into a general plague.

The recent action of the British Council in forbidding the importation of American live cattle is likely to prove of inestimable benefit to this country, in forcibly calling attention to the grave risk that the presence of the disease on Long Island and elsewhere constantly entails. Fortunately the drift of the cattle traffic is eastward, and as yet there has been no propagation of the poison in the great cattle ranges of the West. Unless summarily arrested, however, the disease will surely reach those sources of our cattle supply, and occasion losses that can be estimated only in hundreds of millions of dollars.

The experience of all countries into which this disease has gained access appears to prove that there is only one way of getting rid of it—namely, the immediate killing of all infected cattle, and the thorough disinfection of the premises in which they are found.

The disease is purely infectious, and is never found in regions where it has not gained a foothold by importation. Palliative measures have in every instance failed to eradicate the disease, and are only justifiable, as in Australia, after the plague has reached dimensions utterly beyond the reach of any process of extermination.

Professor Law, of Cornell University, one of our best informed veterinary surgeons, most emphatically opposes every attempt to control the disease by quarantining the sick or by the inoculation of the healthy. "We may quarantine the sick," he says, "but we cannot quarantine the air." To establish quarantine yards is simply to maintain prolific manufacturers of the poison, which is given off by the breath of the sick, and by their excretions, to such an extent that no watchfulness can insure against its dissemination. Besides, the expense of thorough quarantining operations would amount to more than the value of the infected animals whose lives might be saved thereby. Inoculation is still less to be tolerated at this stage of the pest.

The Professor says: "Germany, Holland, Belgium, France, and England, have been treating the victims of this plague for nearly half a century, but the result has only been the increase of disease and death. Our own infected States have been treating it for a third of a century, and to-day it exists over a wider area than ever before. Contrast this with the results in Massachusetts and Connecticut, where the disease has been repeatedly crushed out at small expense, and there can be no doubt as to which is the wisest course. As all the plagues are alike in the propagation of the poison in the bodies of the sick, I may be allowed to adduce the experience of two adjacent counties in Scotland when invaded by the rinderpest. Aberdeen raised a fund of £2,000, and though she suffered several successive invasions, she speedily crushed out the poison wherever it appeared by slaughtering the sick beasts and disinfecting the premises. The result was that little more than half the fund was wanted to reimburse the owners for their losses, and the splendid herds of the county were preserved. Forfar, on the other hand, set herself to cure the plague, with the result of a universal infection, the loss of many thousands of cattle, and the ruin of hundreds of farmers. Finally the malady was crushed out in the entire island by the method adopted by Aberdeen and other well advised counties at the outset."

And again, "Cattle have been inoculated by the tens of thousands in Belgium and Holland, and of all Europe these are the countries now most extensively infected. France, Prussia, Italy, Austria, and England have each practiced it on a large scale, and each remains a home of the plague. Australia has followed the practice, and is now and must continue an infected country. Our own infected States have inoculated, and the disease has survived and spread in spite of it, and even by its aid. Whatever country has definitively exterminated the plague (Norway, Sweden, Denmark, Holstein, Mecklenburg, Switzerland, Massachusetts, and Connecticut), that country has prohibited inoculation and all other methods that prevail on the principle of preserving the sick, and has relied on the slaughter of the infected and the thorough disinfection of their surroundings. So will it be

with us. If any State adopts or allows any of these temporizing measures, that State will only repeat the experience of the past alike in the Old World and the New, will perpetuate the disease in the country, will entail great losses on its citizens, will keep up the need for constant watchfulness and great expense by the adjoining States for their own protection, and will indefinitely postpone the resumption of the foreign live stock trade, which, a few months ago, promised to be one of the most valuable branches of our international commerce."

We are persuaded that the position taken by Professor Law, and other similar-minded veterinary surgeons, is the only safe one. The disease can be stamped out now with comparatively small loss. If trifled with, and tolerated, it cannot but result in a great national calamity.

SPAIN A FIELD FOR MACHINERY AND PATENTS.

From a too lengthy communication to admit in full to our columns, a resident of Madrid communicates to the SCIENTIFIC AMERICAN some facts relative to the fertility of the soil of Spain, her necessity for improved agricultural and other implements, and closes with the assertion that it is a good field withal for patents. We cull from the letter as follows:

I have lived, says the writer, for a number of years in this beautiful country, so little understood by foreigners, so little appreciated by its own inhabitants. The Spain of romance, poetry, and song, is the garden as well as the California of Europe. But it stands in great need of the health-giving touch of the North American enterprise. We have here the same mineral treasures, the same unrivaled advantages of climate, that made Spain once the industrial and commercial emporium of the world.

But Spain is awakening. She is endeavoring to shake off her lethargy. The late Exhibition of Paris has proved this; and those who are familiar with the past history and present condition of Spain have been astonished at the result of this effort. A new era has commenced for the country, and it is everywhere evident that a strong current of enterprise and industry has set in. But it is with nations, as with individuals, when they have remained long in complete inaction, brain and muscles are torpid and cannot at first obey the will. Spain needs the assistance of other nations hardened and inured to toil.

The plows now used to till the land are precisely such as were those left by the Moors in the unfinished furrow, when with tears and sighs they bade farewell to their broad fields, their mosques and palaces, whose ideal architecture is still the wonder of the world, to go forth as outcasts and exiles in obedience to the cruel edict that drove them away to the deserts of Africa.

I doubt whether there is an American plow in Spain, much less a steam plow. Sowing and reaping machines are here unknown, and grain is tread out by oxen and mules just as it was in Scripture times, and cleaned by women, who toss it in the air to scatter the chaff. Everything is primitive and Oriental here as yet.

Spain could supply all Europe with butter and cheese, and, on the contrary, these articles are imported in large quantities from England, Holland, and Switzerland. The traveler crosses leagues and leagues of meadow land where not a tree is to be seen, nor one sheep pasture, and which are nevertheless watered by broad rivers that carry away to the ocean the water that would, by irrigation, convert these fields into productive farms. There are many places in Spain where the wine is thrown away for want of purchasers and vats in which to keep it. In the Upper Aragon, the mortar with which the houses are built is made with wine instead of water, the former being the most plentiful. Aragon needs an enterprising American company to convert into wholesome table wine the infinite varieties there produced, and which our neighbors the French buy and carry away to convert into Bordeaux.

We want American enterprise in Galicia and Asturias, where milk is almost given away, to convert it into the best of butter and cheese; and also in those same provinces, where delicious fruit is grown in such abundance that it is left on the ground for the swine.

Spain needs many more railroads and canals, all of which, when constructed, are subsidized by the government; the railroads at the rate of \$12,000 a kilometer, and many more additional advantages are offered for canals.

With regard to commerce with Spain, we have to lament the same indifference on the part of the Americans. I have, for instance, an American double-burner petroleum lamp. All who see it admire and covet it, but they are not to be had here. If we except one American in Madrid, who brings mostly pumps and similar articles on a very small scale, we have no dealers in American goods here. Wooden clothes pins, lemon squeezers, clothes horses, potato peelers, and the hundreds of domestic appliances of American invention, elsewhere considered indispensable, are in Spain unknown.

We had confidently expected that the new Spanish law on patents would draw the attention of American inventors toward this country, that to-day offers a wide field for every new practical invention, but I am sorry to see that, with the exception of Edison and a few others, the Americans have not yet availed themselves of the easy facility for taking patents for Spain, where new inventions and new industries are now eagerly accepted and adopted. And while the Americans are thus careless as to their own interests, the

French take out and negotiate, in Spain, American patents with insignificant variations.

Let American inventors be assured that any new invention, useful and practical, and above all, requiring but little capital to establish it as an industry, will find a ready sale in Spain.

I could enlarge to a much greater extent upon the indifference of American inventors, merchants, manufacturers, and business men, as to the market they have in Spain in their respective lines, and upon the importance of building up a trade with this country, but to do so would require more space than I think you would feel justified in occupying in your columns.

PETER COOPER AS AN INVENTOR.

The successes of Peter Cooper's long and useful life are well known. Not so many are aware of his varied experience in the direction of failure, particularly in the field of invention. More than once he has found his best devices profitless because ahead of his time, or because of conditions, political or otherwise, which no one could foresee. He possessed the rare qualities, however, of pluck and perseverance, and when one thing failed he lost no time in trying something else. Before he was of age he had learned three trades—and he did not make his fortune at either.

In a familiar conversation with a *Herald* writer recently, Mr. Cooper related some of his early experiences, particularly with reference to enterprises which did not succeed. His father was a hatter, and as a boy young Cooper learned how to make a hat in all its parts. The father was not successful in business, and the hatter's trade seems to have offered little encouragement to the son. Accordingly he learned the art of making ale. Why he did not stick to that calling and become a millionaire brewer, Mr. Cooper does not say. Most probably the national taste for stronger tipple could not at that time be overcome, and ale could not compete with New England rum and apple-jack. The young mechanic next essayed the art of coachmaking, at which he served a full apprenticeship. At the end of his time his employer offered to set him up in business, but the offer was not accepted, through fear of losing another's money. He felt that if he took the money and lost it he would have to be a slave for life. So he quit coachmaking and went to work for a man at Hempstead, L. I., making machines for shearing cloth. In three years, on \$1.50 a day, Cooper had saved enough money to buy his employer's patent. Immediately he introduced improvements in the manufacture and in the machine, which the war with England made a great demand for by excluding foreign cloths. At this time Cooper married. In due time the family numbered three, and the young father's inventive faculty was again called upon.

"In those days," said Mr. Cooper to the reporter, smiling as the remembrance came to his mind, "we kept no servants as they do nowadays, and my wife and myself had to do all that was to be done. After our first child was born I used to come into the house and find my wife rocking the cradle, and I relieved her from that while I was there. After doing that for a few days I thought to myself that I could make that thing go of itself. So I went into my shop, and made a pendulous cradle that would rock the child. Then I attached a musical instrument which would sing for it, and at the same time the machine would keep the flies off. The latter was very simple; by hanging something to the cross bar, as the cradle swung under it, backward and forward, it would create wind enough to drive away the flies. The machine was wound up by a weight, and would run for nearly half an hour without stopping. I took out a patent for it, and one day a peddler came along with a horse and wagon, as they do in the country, and saw the cradle. He struck a bargain with me and bought the patent right for the State of Connecticut, giving for it his horse and wagon and all the goods he had with him. They afterward made some there, but nothing like as good as mine. It was a beautiful piece of furniture," said Mr. Cooper regretfully, as he thought of it as a thing of the past. "They afterward substituted springs for the weight movement, but that kind was not so good."

About this time the war with England ended and the market was spoiled for the shearing machines. Then, we believe, Mr. Cooper tried his hand at cabinetmaking, but that failed, and he set up a grocery store where the Bible House now stands. While selling groceries Mr. Cooper made an invention which ought to have made his fortune, but it did not. The story is best told in Mr. Cooper's own words:

"It was just before the Erie Canal was completed, and I conceived a plan by which to tow boats by the use of all the elevated waters on the line of the canal. To demonstrate that that was practicable I made with my own hands a chain two miles long, and placed posts 200 feet apart in the East River from Bellevue dock down town about a mile. These posts supported grooved wheels to lay the chain in, forming an endless chain. The whole was moved by an overshot water-wheel placed at the Bellevue dock. A reservoir twelve feet square and three deep held the water to turn the wheel."

At the suggestion of Governor Clinton Mr. Cooper tightened his chain and pulled up the end post just before the grand trial of his device was to come off. He succeeded in getting stone enough to anchor the post, however, and the experiment went off swimmingly. The boat was hooked on to the chain, and the passage back and forward—two miles—was made in eleven minutes.

"I ran that boat some ten days," says Mr. Cooper, "to let people see what could be done, and carried nearly a thousand people. Part of the time I ran two boats. Once I counted

52 people in one boat. I made the whole chain myself and planted the posts. As I could find no wheels to suit me I made the moulds and cast the wheels myself out of block tin and zinc. It was no small job, I can tell you."

This was unquestionably a grand invention. In itself it was a perfect success; but it was not used. Mr. Cooper tells why:

"It demonstrated completely that the elevated water power along the line of the canal and every lock in the canal could be made use of to drive the boats. Governor Clinton gave me \$800 for the privilege of buying the right to the plan in case he should want to use it on the Erie Canal. In making the canal he had promised the people along the route that as soon as it was finished they could sell their horses to tow the boats, their grain and fodder to feed the horses, and their provisions for the passengers. On reflection he thought that if he took all that away from them he would have to run the gantlet again, and he could not afford to do that. There never was anything done with the plan until a few years ago, when Mr. Welch, president of the Camden and Amboy Railroad and Canal, invented exactly the same thing and put it in practice on his locks on the canal. He found it saved half the time and great expense. He went to Washington to take out a patent for it, and when he got there he found that I had patented the same thing fifty-three years before. My patent had run out, so he could use the plan on his canal. It has also been used on one lock on the Erie Canal. If they could have used that chain on the whole length of the Erie Canal it would have saved many millions of dollars."

This would not be a bad place, were there room for it, to speak of "undeveloped" and therefore worthless inventions; and the assumption that if an inventor does not make his invention immediately profitable it must be good for nothing, and should be dispatented. But the moral goes without telling.

Mr. Cooper's next attempt at invention was made about the same time, but in quite a different direction. It was during the struggle of the Greeks for independence, and wishing to do something for their assistance, Mr. Cooper undertook to make a torpedo boat for them. Mr. Cooper says:

"It was a small one that could be taken on board ship and used to destroy any vessel that came to destroy them. It was fixed with a rotary steam engine and a screw wheel to propel it. It was intended to be guided from the ship or the shore. There were two steel wires fixed to the tiller of the rudder, and the operator could pull on one side or the other and guide the vessel just as a horse is guided with reins. It was so arranged that at night it would carry a light with its dark side toward the object to be destroyed, and by simply keeping the light in range with the vessel it would be sure to hit it. The torpedo was carried on a little iron rod, projecting in front of the torpedo vessel a few inches under water. Contact would discharge the torpedo and bend this iron rod. This would reverse the action of the engine and cause the torpedo vessel to return right back from whence it came, ready to carry another torpedo."

Unfortunately the torpedo boat was not ready in time to go with the ship carrying the contributions for Greece. It was stored in Mr. Cooper's factory (he had then turned his attention to glue) and was destroyed by the burning of the factory. It seems to have been quite a promising affair for the time. Mr. Cooper says:

"I experimented with it at once to see how far it could be guided. I made a steel wire ten miles long and went down to the Narrows to test the matter. I had steel yards fastened to one end of the wire, and to the other end the torpedo vessel was attached. It got about six miles away when a vessel coming into the harbor crossed the wire and broke it. Although the experiment was not complete it showed that for at least six miles I could guide the vessel as easily as I could guide a horse."

Mr. Cooper's work as the pioneer locomotive builder in this country; his later inventions and improvements in the manufacture of railway iron and wrought iron beams for fire-proof buildings; his application of anthracite coal to iron puddling, and his other successes are almost as widely known as his philanthropic efforts for the education and advancement of the industrial classes of this city.

After all, we are not sure but the story of his long and varied and always honorable career, told by himself, would not be worth, to young people who have to make their way in life through many difficulties, more even than the advantages of the noble institution which bears his name.

TASTE FOR READING.—Sir John Herschel has declared that "if he were to pray for a taste which should stand under every variety of circumstance and be a source of happiness and cheerfulness to him through life, it would be a taste for reading." Give a man, he affirms, that taste, and the means of gratifying it, and you cannot fail of making him good and happy; for you bring him in contact with the best society in all ages, with the tenderest, the bravest, and the purest men who have adorned humanity, making him a denizen of all nations, a contemporary of all times, and giving him a practical proof that the world has been created for him, for his solace, and for his enjoyment.

Africa Crossed Again.

Information has been received by way of Lisbon, March 12, that the Portuguese explorer, Pinto, has succeeded in traversing Africa from west to east, and has reached Transvaal. The latitude of his course across is not mentioned.

CURIOUS FACTS IN MAGNETISM.

At the meeting of the New York Academy of Sciences February 17th, the article in the March number of *Harper's Magazine*, entitled "Gary's Magnetic Motor," was incidentally alluded to, and Prof. C. A. Seeley made the following remarks: The article claims that Mr. Gary has made a discovery of a neutral line or surface, at which the polarity of an induced magnet, while moving in the field of the inducing pole, is changed. The alleged discovery appears to be an exaggerated statement of some curious facts, which, although not new, are not commonly recognized. If a bar of iron be brought up, end on, near a magnetic pole, the bar becomes an induced magnet, but an induced magnet quite different from what our elementary treatises seem to predict. On the first scrutiny it is a magnet without a neutral point, and only one kind of magnetism—namely, that of the inducing pole. Moreover, the single pole is pretty evenly distributed over the whole surface, so that if iron filings be sprinkled on the bar they will be attracted at all points and completely cover it. Now, if while the bar is covered by filings it be moved away from the inducing pole, the filings will gradually and progressively fall, beginning at the end nearest the inducing pole and continuing to some point near the middle of the bar; the filings at the remote end will generally be held permanently. When the bar is carried beyond the field of the inducing pole it is simply a weak magnet of ordinary properties—i. e., of two poles and a neutral point between them.

A plausible and simple explanation of this case is that the inducing pole holds or binds the induced magnetism of opposite name, so that it has no external influence; the two magnetisms are related to each other as are the positive and negative electricities of the Leyden jar. Let the inducing pole be N.; the S. of the bar will be attracted by it and bound, while the N. of the bar becomes abnormally free and active. On moving the bar from the pole the bound magnetism is released and a part becomes residual magnetism. Now when the residual balances the free magnetism which is of opposite name, we are on Gary's neutral line. In a restricted sense there is a change of polarity over the half of the bar contiguous to the inducing pole; on the other half there is no change of pole in any sense. Experiment with a shingle nail in the place of the filings, à la Gary, bring the nail to the induced bound pole, and it may be held, except at the neutral line. Now if one will read the magazine article with such ideas as these he will feel pretty sure that the writer of it has used words recklessly, that Gary has not made an original discovery, and that the "neutral" line, whatever it be, has only an imagined relation to the "principle" of the motor.

The Gary Motor as a perpetual motion scheme, of course, is not worthy of serious notice from a society devoted to science. It has no noteworthy novelty of construction or conception. Mr. Gary is afflicted with the very old delusion of the cut-off or shield of magnetism, which is to cost less than what comes from it. His cut-off is a sheet of iron, which we know acts simply as an armature.

A New Phenomenon in Static Electricity.

M. E. Duter, in a paper read before the French Academy in December, showed that when a Leyden jar is charged with either positive or negative electricity its internal volume increases, and that this effect is a new phenomenon, unexplainable by either a theory of an increase of temperature or of an electrical pressure. The experiment was performed by means of a flask-shaped Leyden jar with a long tube attached to its neck, and containing a liquid which served as the inner armature. The author's attention had been called to the fact that this phenomenon had been observed ten years ago by M. Gori.

His researches, just made public, leave no doubt of the accuracy of M. Duter's view, that the glass of the jar really expands. According to the theory of elasticity, the effect of an internal pressure in a hollow sphere is in the inverse ratio of its thickness. M. Duter, therefore, had three flasks made of the same volume, but of thicknesses of 4 mm., 0.8 mm., and 0.5 mm. respectively. They were filled with water and enveloped by tin foil. Each carried a capillary thermometer tube, in which the variations of the height of liquid served to measure the changes in volume due to electrification. He found that these changes were imperceptible in the thick glass, very marked in the flask of mean thickness, and rose to 30 mm. in the thinnest. The variations in volume were very nearly in inverse ratio of the square roots of the thicknesses.

A NEW ORE CRUSHER.

The accompanying engravings represent an improved ore

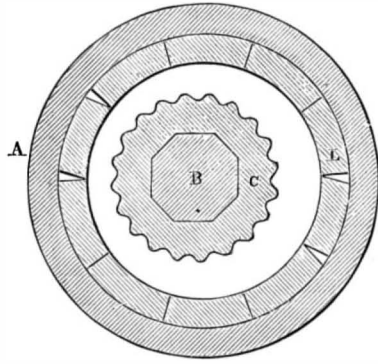

Fig. 2.—HORIZONTAL SECTION.

crusher, which is said to be very effective and economical in the use of power.

A short vertical cast iron cylinder, A, having in one side

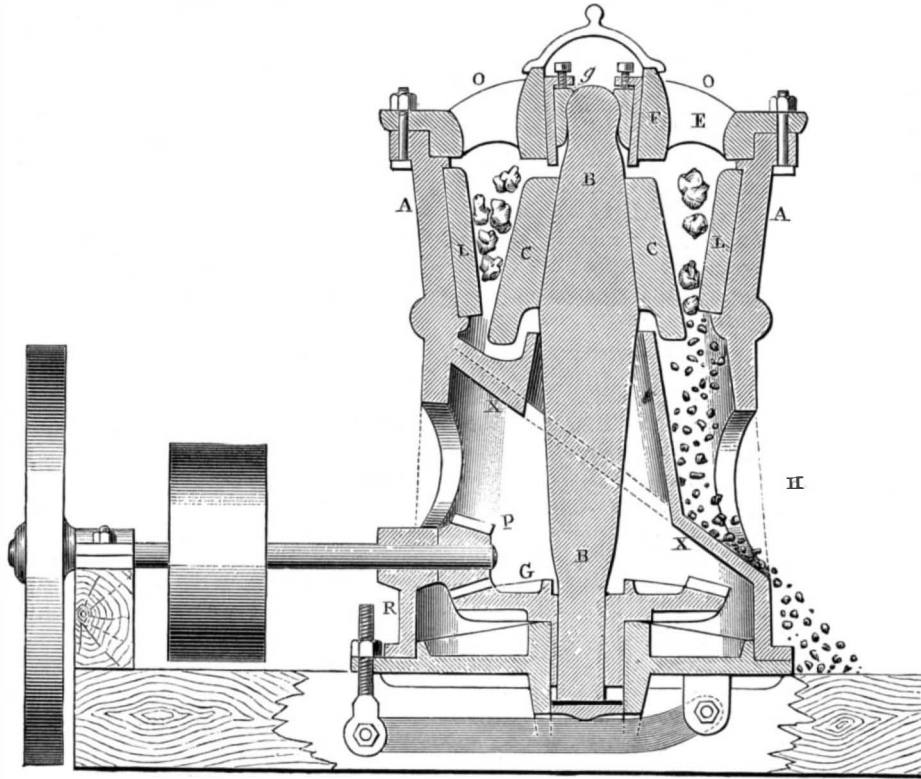

Fig. 1.—BROWN'S ORE CRUSHER.

a discharge opening, H, contains all of the movable parts.

The upper portion of the cylinder is lined with chilled iron plates, L, and an inclined chute, X, leads to the discharge opening, H.

A rigid shaft, B, carries the circular crusher, C, and moves in a ball and socket joint at the upper end, and extends eccentrically through the boss of a bevel wheel, G, at its lower end, and rests on a step supported by a lever that may be adjusted by the screw, R. The wheel, G, is driven by the pinion, P, on whose shaft there are a pulley and a fly-wheel.

The double gyratory motion of the crusher, C, causes it to approach all portions of the lining, L, crushing whatever lies between.

It is said that this machine is capable of crushing 10 tons of the hardest ore per hour. Its weight is 6,500 lbs.—*Musée de l'Industrie*.

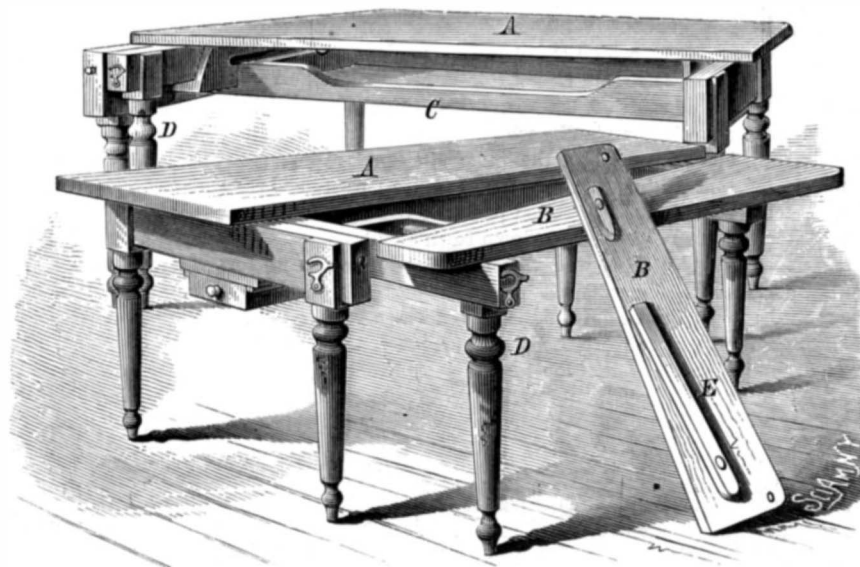

HOGINS' IMPROVED TABLE.

RECENT AMERICAN PATENTS.

Enos Richmond, of Troy, N. Y., has invented a steak tenderer, having a plunger studded with chisel-pointed rods, and arranged in a case in connection with an elevating spring. A blow upon the knob at the top of the plunger forces the chisel-pointed rods through holes in the casing into the meat, the casing resting on the surface of the steak.

Messrs. A. W. Southard and Volney R. Sears, of Falls City, Neb., have patented an improved invalid bedstead, which is provided with ingenious mechanism for placing the invalid in different positions.

An improved spring attachment for carriage tops, which is designed to prevent the rear bow from being bent by the weight of the top when turned back, has been patented by Mr. Robert E. McCormick, of Doylestown, O.

Mr. Espy Gallipher, of Schellsburg, Pa., has devised an axle journal having a groove lengthwise upon its upper side which extends back upon the surface of the axle and communicates with an oil cup. A sliding rod occupies a portion of the groove; when this rod is drawn out it permits the oil to fill the groove; when it is pushed into the groove in the axle, the oil is ejected and a further supply is cut off.

An improved pill machine, invented by Messrs. W. N. Fort and R. R. Moore, of Lewisville, Ark., is adapted to the manufacture of pills in large quantities. The machine has mechanism for grinding and mixing ingredients, a grooved wheel and trough for forming the pills, and a device for applying powder.

An improvement in millstone adjustments has been patented by Mr. Stephen P. Walling, of South Edmeston, N. Y. This invention consists in a screw applied to the end of the mill spindle on which the stone is rigidly held, so that the running stone may be forced by the screw away from the stationary stone and held against the action of a spring at the opposite end of the spindle, the object being to prevent the stones from becoming dulled by contact with each other.

An improved attachment for sewing machines for soaking or waxing the thread as it passes the needle, has been patented by Mr. Pedro F. Fernandez, of San Juan, Porto Rico. The invention consists in a frame secured to the arm of a sewing machine by a thumb-screw, and provided with a clamping device for holding wax or soap.

A novel combination of a toggle and springs and levers for operating a drag saw has been patented by Mr. Harvey Hughes, of Wheat Ridge, Ohio. The saw, while properly guided, is free to move up or down without affecting the leverage.

An improvement in filters, which consists in re-enforcing the felt disk with a backing of wire cloth to enable it to resist heavy water pressure, has been patented by Mr. B. P. Chatfield, of Aiken, S. C.

A basket having light sheet metal sides attached to a wooden bottom by crimping the edges over a rib on the periphery of the bottom, has been patented by Mr. Samuel Friend, of Decatur, Ill. The handle and lid may be easily removed to permit of packing and storage.

An improved cross bar for fastening doors, patented by Mr. Richard Condon, of La Salle, Ill., has a spring acted portion which engages a socket on the door casing, and is retained in that position by a spring catch.

A NEW IRONING TABLE.

The accompanying engraving represents a convenient and inexpensive table recently patented by Mr. Albert H. Hogins, of Morrisania, N. Y. It is more especially designed for ironing, but it may be used for other purposes when closed up. The top is made in two tapering sections, A B. The section, B, is narrower than the other, and is pivoted at its wider end to a bar, E, which slides into a socket formed in the table. The table has five legs, one of which, D, is attached to a sliding rail that supports the narrower end of the movable part of the top. The table is provided with a drawer in one end and with a tray, C, for containing blankets, etc.

The convenience and practicability of this table for general laundry use, will be apparent without further explanation. The board, B, when drawn out will be used for ironing skirts, shirts, and other garments requiring a board of this character, and when the table is closed together and fastened by the hooks, it may be used in ironing larger articles. When closed it presents the appearance of an ordinary table and may be used as such.

Further information may be obtained by addressing the inventor as above.

A NOVEL ENGINE REGULATOR.

The accompanying engraving represents two different styles of regulator, invented by Mr. Stenberg, in which the effect of centrifugal force is utilized. In a vessel, A, of parabolic shape is placed a disk, C, which floats on glycerine contained by the vessel, and is attached to the walls of the vessel by an annular membrane, so that it may rise and fall in a vertical direction as the glycerine is carried with more or less force toward the edge of the vessel by centrifugal action. The inner surface of the vessel, A, is provided with radial grooves, by which the rotary motion of the vessel is communicated to the glycerine. To the center of the disk, C, is attached a vertical rod, which extends downward through the hollow shaft and is connected with governor valve. An increase of speed throws the glycerine toward the periphery of the valve, and, raising the disk, C, closes the steam valve; a diminution of speed permits the glycerine to fall back, when the disk descends and the valve opens.

The disk, C, has a small aperture for the admission and escape of air, and the apparatus is adjusted by pouring lead into the groove in the disk.

The regulator shown in Fig. 2 operates upon the same principle, but it is adjusted by means of a spring.

This apparatus is manufactured by Blancke Bros., Magdeburg.—*Musée de l'Industrie.*

A Strange People.

Botel Tobago is an island in the South Seas which has lately been visited by a party of United States naval officers. They were surveying a rock east of the South Cape of Formosa, and called at this island. They found a curious race of Malay stock. These aborigines did not know what money was good for. Nor had they ever used tobacco or rum. They gave the officers goats and pigs for tin pots and brass buttons, and hung around the vessel all day in their canoes waiting for a chance to dive for something which might be thrown overboard. They wore clouts only, ate taro and yams, and had axes, spears, and knives made of common iron. Their canoes were made without nails, and were ornamented with geometrical lines. They wore the beards of goats and small shells as ornaments.

Such is the account of these strange people given by Dr. Siegfried, in a letter read at the last meeting of the Philadelphia Academy of Natural Sciences.

REMEDY FOR THE NEW CARPET BEETLE.

Noticing a statement made by Mr. J. A. Lintner, to the effect that the Persian insect powder would probably prove unavailing as a remedy against the ravages of the new carpet beetle (*Anthrenus*), W. L. Carpenter, of the U.S.A., was led to institute some experiments with this well known insecticide, the results of which he communicates to the current number of the *Naturalist*. A small quantity of the powder was introduced, on the point of a penknife, under a tumbler beneath which various insects were consecutively confined. The movements of the insects brought them in contact with the poison, which readily adhered to their body; in endeavoring to remove it from their appendages a few particles would be carried to the mouth and thence to the stomach, with fatal effect. The results were briefly thus: A honey bee became helpless in 15 minutes; a mad wasp in 8 minutes; a small ant in 5 minutes; a large butterfly resisted the effects for over an hour, and apparently recovered, but died the next day; a house-fly became helpless in 10 minutes; a mosquito in 15; and a flea in 3 minutes. In experimenting on beetles, an insect was secured as nearly the size of the carpet beetle as could be found. It was easily affected, and became helpless in 12 minutes.

In these, and experiments with various other insects, the scent from the powder did not produce any bad effect on those subjected to its odor where actual contact was not possible; but when carried to the mandibles the effect was to produce complete paralysis of the motor nerves. The experiments prove that all insects having open mouth parts are peculiarly susceptible to this popular insecticide. As a result, the writer does not hesitate to recommend the powder to housekeepers as an infallible agent in destroying the carpet beetle and preventing its ravages. The Persian insect powder liberally sprinkled upon the floor before putting down a carpet, and afterward freely placed around the edges, and never swept away, will suffice to preserve a large sized carpet. No ill effects from its use need be feared by the householder, since the drug is poisonous to no kinds of animals except insects.

Banana Flour.

The banana has recently found a new use in Venezuela. It has the property of keeping the soil moist round it, in a country where sometimes no rain falls for months; so it has been employed to give freshness, as well as shade, to the coffee plant, whose cultivation has been greatly extended (Venezuela produced 38,000,000 kilogrammes of coffee in 1876). The Venezuelans can consume but little of the banana fruit thus furnished, so that attention is being given to increasing its value as an export. At the Paris Exhibition

were samples of banana flour (got by drying and pulverizing the fruit before maturity) and brandy (from the ripe fruit). The flour has been analyzed by MM. Marcano and Muntz. It contains 66.1 per cent of starch, and only 2.9 of azotized matter.

NEW STENCIL PEN.

The accompanying engraving shows new form of stencil pen invented by Mr. J. W. Brickenridge, of La Fayette, Ind. In Fig. 1 the entire apparatus is shown in perspective; Fig.

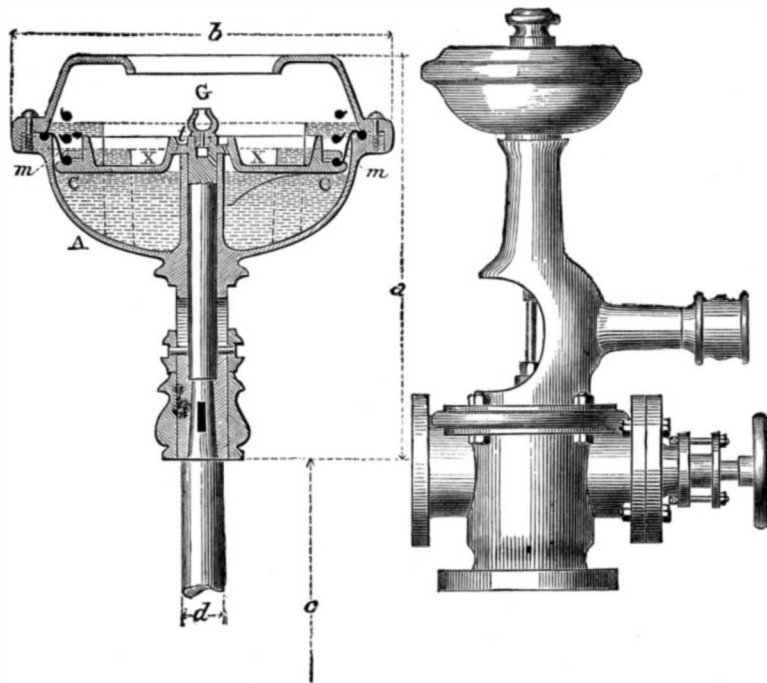
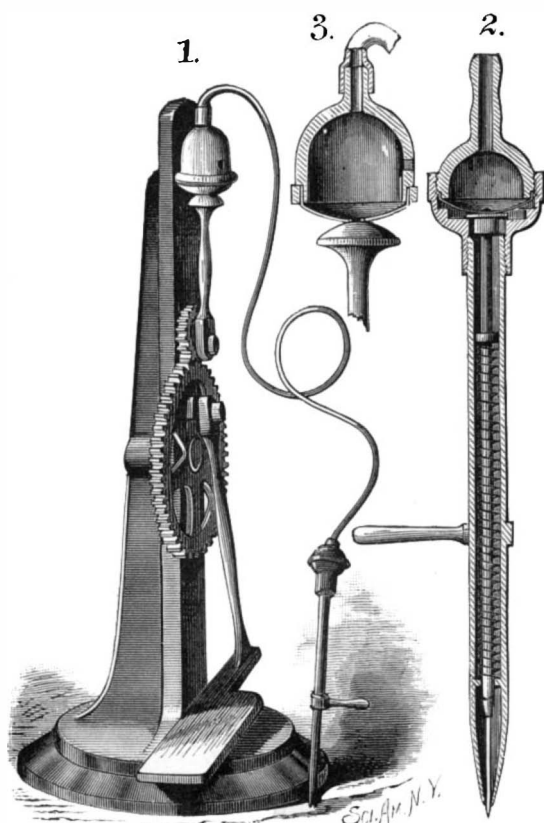

Fig. 1 Fig. 2
STENBERG REGULATOR.

2 is a longitudinal section of the pen; and Fig. 3 is a vertical section of a portion of the driving apparatus. In this instrument compressed air is used as a motive force for driving the perforating needle. The inverted cup, shown in detail in Fig. 3, has its mouth closed with a flexible diaphragm, which is vibrated rapidly by a pitman having a convex end attached by its center to the middle of the diaphragm. The pitman is reciprocated by a simple treadle motion, which will be readily understood by reference to Fig. 1.

The cup has a small aperture covered by a valve to admit of the entrance of air when the diaphragm is drawn down. The pen, shown in detail in Fig. 2, has a cup and flexible diaphragm similar to the one already described. The diaphragm rests upon the enlarged end of a bar which carries at its lower end a perforating needle. The pen is connected with



BRICKENRIDGE'S PNEUMATIC STENCIL PEN.

the driving mechanism by a flexible tube. The needle bar is pressed lightly against the diaphragm by a spiral spring.

When the treadle motion is operated the impelling diaphragm is rapidly vibrated, and through the medium of the air contained in the flexible tube it communicates motion to the pen diaphragm and consequently to the needle bar and needle. If, while the needle is reciprocated in this way, the pen is moved over the surface of the paper, a line of fine perforations will be made. With this instrument stencils may be made for making multiplied copies of maps, drawings, and manuscripts.

Origin and Progress of Ocean Telegraphy.

At the celebration in this city of the twenty-fifth anniversary of the formation of the company for laying the first Atlantic cable, Monday, March 10, the projector of the enterprise, Mr. Cyrus W. Field, spoke as follows:

NEIGHBORS AND FRIENDS: Twenty-five years ago this evening, in this house, in this room, and on this table, and at this very hour, was signed the agreement to form the New York, Newfoundland and London Telegraph Company—the first company ever formed to lay an ocean cable.

It was signed by five persons, four of whom—Peter Cooper, Moses Taylor, Marshall O. Roberts, and myself—are here to-night. The fifth, Mr. Chandler White, died two years after, and his place was taken by Mr. Wilson G. Hunt, who is also present. Of my associates, it is to be said to their honor—as might have been expected from men of their high position and character—that they stood by the undertaking manfully for twelve long years, through discouragements such as nobody knows but themselves. Those who applaud our success know little through what struggles it was obtained. One disappointment followed another, till "hope deferred made the heart sick." We had little help from outside, for few had any faith in our enterprise. But not a man deserted the ship: all stood by it to the end. My brother Dudley is also here, who, as the counsel of the company, was present at the signing of the agreement, and went with Mr. White and myself the week after to Newfoundland, to obtain the charter, and was our legal adviser through those anxious and troubled years, when success seemed very doubtful. At St. John's the first man to give us a hearty welcome, and who aided us in obtaining our charter, was Mr. Edward M. Archibald, then Prime Minister of Newfoundland, and now for more than twenty years the honored representative of Her Majesty's Government at this port, who is also here to-night. It is a matter for

grateful acknowledgment that we were spared to see accomplished the work that we began; and that we meet now, at the end of a quarter of a century, to look with wonder at what has been wrought since in other parts of the world.

Our little company came into existence only a few weeks before the Western Union Telegraph Company, which is entitled to share in our congratulations, and has kindly brought a connecting wire into this room, by which we can this evening communicate with every town and village from the Atlantic to the Pacific; and by our sea cables, with Europe, Asia, Africa, Australia, New Zealand, the West Indies, and South America. While our small circle has been broken by death but once, very different has it been with the Atlantic Telegraph Company, which was formed in London in 1856, to extend our line across the ocean. At its beginning there were eighteen English and twelve American directors, thirty in all, of whom twenty-nine have either died or retired from the board. I alone still remain one of the directors.

Many of the great men of science on both sides of the Atlantic, who inspired us by their knowledge and their enthusiasm, have passed away. We have lost Bache, whose Coast Survey mapped out the whole line of the American shores; and Maury, who first taught us to find a path through the depths of the seas; and Berryman, who sounded across the Atlantic; and Morse; and last, but not least, Henry. Across the water we miss some who did as much as any men in their generation to make the name of England great—Faraday and Wheatstone, Stephenson and Brunel—all of whom gave us freely of their invaluable counsel, refusing all compensation, because of the interest which they felt in the solution of a great problem of science and engineering skill. It is a proud satisfaction to remember that while the two Governments aided us so generously with their ships, making surveys of the ocean, and even carrying our cables in the first expeditions, such men as these gave their support to an enterprise which was to unite the two countries, and in the end to bring the whole world together.

Others there are, among the living and the dead, to whom we are under great obligations. But I cannot repeat the long roll of illustrious names. Yet I must pay a passing tribute to one who was my friend, as he was the steadfast friend of my country—Richard Cobden. He was one of the first to look forward with the eye of faith to what has since come to pass. As long ago as 1851 he had a sort of prophet's dream that the ocean might yet be crossed, and advised Prince Albert to devote the profits of the great London Exhibition of that year to an attempt thus to unite England with America. He did not live to see his dream fulfilled.

But though men die, their works, their discoveries, and their inventions live. From that small beginning under this roof, arose an art till then scarcely known, that of telegraphing through the depths of the sea. Twenty-five years ago there was not an ocean cable in the world. A few short lines had been laid across the channel from England to the Continent, but all were in shallow water. Even science hardly dared to conceive of the possibility of sending human intelligence through the abysses of the ocean. But when we struck out to cross the Atlantic, we had to lay a cable over 2,000 miles long, in water over 2 miles deep. That great success gave an immense impulse to submarine telegraphy

then in its infancy, but which has since grown till it has stretched out its fingers tipped with fire into all the waters of the globe. "Its lines have gone into all the earth, and its words to the ends of the world." To-day there are over 70,000 miles of cable, crossing the seas and the oceans. And, as if it were not enough to have messages sent with the speed of lightning, they must be sent in opposite directions at the same moment. I have just received a telegram from Valentia, Ireland, which reads, "This anniversary witnesses duplex working across the Atlantic as an accomplished fact"—by which the capacity of all our ocean cables is doubled.

Who can measure the effect of this swift intelligence passing to and fro? Already it regulates the markets of the world. But better still is the new relation into which it brings the different kindreds of mankind. Nations are made enemies by their ignorance of each other. A better acquaintance leads to a better understanding; the sense of nearness, the relation of neighborhood, awakens the feeling of brotherhood. Is it not a sign that a better age is coming, when along the ocean beds strewn with the wrecks of war, now glide the messages of peace?

One thing only remains which I still hope to be spared to see, and in which to take a part, the laying of a cable from San Francisco to the Sandwich Islands—for which I have received this very day a concession from King Kalakaua, by his Minister, who is here to-night—and from thence to Japan, by which the island groups of the Pacific may be brought into communication with the continents on either side—Asia and America—thus completing the circuit of the globe.

But life is passing, and perhaps that is to be left to other hands. Many of our old companions have fallen, and we must soon give place to our successors. But though we shall pass away, it is a satisfaction to have been able to do something that shall remain when we are gone. If in what I have done to advance this enterprise, I have done something for the honor of my country and the good of the world, I am devoutly grateful to my Creator. This has been the great ambition of my life, and is the chief inheritance which I leave to my children.

Correspondence.

The Gary Motor.

To the Editor of the Scientific American:

In your article on the "Gary Motor," issue of March 8, page 144, you say: "There is no neutral line in the sense that polarity changes when Mr. Gary moves his piece of sheet iron with its attached shingle nail across the pole or near the pole of a magnet." "The most delicate instruments fail to detect such a change of polarity," etc. Mr. Gary's claim of a neutral line is of course absurd, but you are wrong in saying that the polarity does not change under the conditions described in the *Harper's Monthly* article. Mr. Gary is perfectly correct in claiming a change of polarity in that experiment, although his other claim of deriving from this change of polarity a continuous motion without consuming energy are manifestly absurd.

The change of polarity is easily explained. If a bar of soft iron, whose length is two or three times the distance between the poles of the horseshoe magnet, be placed in front of the latter as in the sketch, and at some distance, poles will be induced, as shown by the letters N S. Now let the bar approach the magnet. When within a short distance consequent points will be formed and the polarity at the ends will be reversed.

the bar having four poles, as in the second sketch. The bar of soft iron must have certain dimensions depending on the size and power of the horseshoe magnet. By using a powerful electro-magnet in place of a permanent one, a soft iron bar of considerable size may be used, and the change of polarity exhibited by showing the repulsion in one case for the south pole and in the other for the north pole of a heavy permanent magnet. When in the proper position a very small movement of the soft iron bar is sufficient to produce the change.

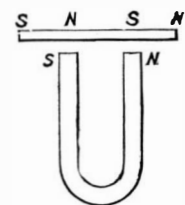

WM. A. ANTHONY.

Cornell University, Ithaca, N. Y., March 2, 1879.

Gary's Neutral Line.

To the Editor of the Scientific American:

I have just read the article in the issue of March 8, on the Gary Motor, and cannot refrain from offering a suggestion on the subject. When I read the article referred to in *Harper's*, I formed the same opinion of the so-called invention that the writer in the *SCIENTIFIC AMERICAN* has expressed, and, in the main, such is my opinion still. I, however, tried the experiment by which Gary claims to prove the existence of his neutral line, and soon found the same explanation that the writer in the *AMERICAN* has given. I then, curiously enough, modified the experiment in precisely the manner he suggests, placing the magnet in a vertical position, and using first a piece of sheet iron and then an iron

wire under it. This was before seeing the article in the *SCIENTIFIC AMERICAN*. My experiment is well illustrated by the writer's diagram, except that the nail should be at the end of the iron wire, where its polarity is of course most strongly marked. But the result is not as he states it. For, as the wire is brought up toward the magnet, the nail drops off before the wire touches the magnet. When the sheet iron is used, the point at which the nail drops off is farther from the magnet than in the case of the wire, and when it is brought nearer it will again pick up the nail, which then continues to cling until the iron touches the magnet and afterwards. Thus the existence of a line in which the soft iron, or induced magnet, does not attract the nail, and above and below which it does attract it, is demonstrated. That the polarity of the induced magnet is reversed when it crosses this line may be demonstrated as follows: When it is held beyond (or below) this line (Fig. 1), the negative pole of the permanent magnet, the positive being kept at a distance, may be made to approach the iron and touch it, without causing the nail to drop. (Fig. 3.) But when contact occurs, the whole of the iron must possess the polarity of that part of the magnet which it touches, namely, negative. Hence in the position indicated in Fig. 1, the polarity of the induced magnet does not correspond with that of the permanent magnet, but is as indicated by the letters. On the other hand, if the positive pole alone be made to approach, the nail will drop; but when it is very near, or in contact, it again holds the nail, and the iron is now positive; and if the negative pole also be now brought into contact, the polarity of the soft iron will correspond with that of the magnet, as shown in Fig. 2.

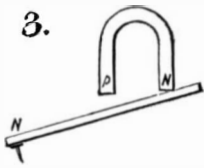
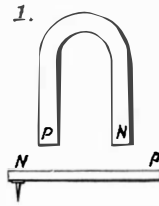

These experiments should be performed with the soft iron under both poles of the magnet, and the ends of the former should extend somewhat beyond the poles of the latter, or the nail is liable to jump to the magnet as the "neutral" line is crossed. The position of the letters in Fig. 1, of the previous article, represents the polarity of the induced magnet to be the same as that of the permanent, which is true only within (or above) the line described; and this, together with his statement that no such line can be discovered, appears to indicate that the writer relied upon his knowledge of the laws of magnetism to state what would be the result, without testing it experimentally. It is probable that this reversal of polarity is susceptible of explanation by the known laws of magnetic currents, but if it has hitherto escaped observation, its discovery is certainly deserving of notice, and may lead to valuable results. Of the fact, any one may easily convince himself by the simple experiments above described.

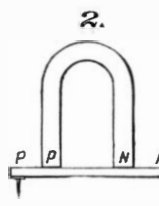

G. H. FELTON, M.D.

Haverhill, Mass., February 28, 1879.

Pneumatic Clocks.

To the Editor of the Scientific American:

In the description of the pneumatic clock, copied from *La Nature*, and published in your journal of date 1st of March, the invention is credited to me. Such is not the case. By an arrangement between Mr. Wenzel, Mr. Brandon of Paris, and myself, patents have been obtained in France, England, etc., for the clock, and issued in my name; but the honor of the invention belongs exclusively to Hermann J. Wenzel, of San Francisco.

Yours faithfully,
E. J. MUYBRIDGE.

San Francisco, Cal., February 27, 1879.

The Ice Cave of Decorah, Iowa.

To the Editor of the Scientific American:

Some years ago I visited the "Ice Cave" of Decorah, Winneshiek county, Iowa, and having since been unable to receive any explanation of the wonderful phenomenon exhibited by it, I write, hoping that you or some correspondent may explain the paradox.

The thriving town of Decorah lies in a romantic valley of the Upper Iowa River, and the cave is almost within its corporate limits. Following the left bank of the stream, one soon reaches the vicinity, and with a hard scramble through a loose shale, up the side of a precipitous hill, forming the immediate bank of the river, the entrance is gained—an opening 5 feet wide and 8 feet high. These dimensions generally describe the cave's section. From the entrance the course is a steep decline—seldom less than 40°. At times the ceiling is so low that progress on hands and knees is necessary. About 125 feet from the entrance the "Ice Chamber" is reached. At this spot the cave widens into a well proportioned room, 8 by 12 feet. The floor is solid ice of unknown thickness, and on the right hand wall of the room a curtain of ice drops to the floor, from a crevice extending horizon-

tally in the rock at the height of one's eyes. Close examination discovers the water oozing from this crevice, and as it finds its way down the side it freezes in the low temperature of the chamber. Singularly this one crevice, and that no wider than a knife edge, furnishes this, nature's ice house, with the necessary water. It was a hot day in August, the thermometer marking 80° in the shade when the visit was made, and comparatively the cold was intense. In common with all visitors, we detached some large pieces of ice and with them hurriedly departed, glad to regain the warmth of the outside world.

The most remarkable fact in connection with this wonder is that the water only freezes in the summer. As the cold of actual winter comes on the ice of the cave gradually melts, and when the river below is frozen by the fierce cold of Northern Iowa, the ice has disappeared and a muddy slush has taken the place of the frigid floor. I would add that the ice chamber forms the terminus of the cave. Beyond a shallow crevice in the crumbling rock forbids further advance. The rock formation of this region is the Portland sandstone.

Why should the temperature of the ice chamber be such as to freeze the water trickling into it? And above all, why should the ice disappear with the cold of winter?
Mansfield, O. H. M. W.

THE WRITING TELEGRAPH.

On the evening of February 26, 1879, the writing telegraph of Mr. E. A. Cowper, of London, was exhibited in operation before the Society of Telegraph Engineers, in that city. It is a curious and remarkable invention. By its use the handwriting of the operator may be transmitted, but a double circuit, that is, two telegraph wires, are used. The operator moves with his hand an upright pointer or stylus, with which he writes the message on paper. The stylus has two arms connected with it, one of which arms, when the stylus makes an upward movement, causes a current to be sent over one wire, while the other arm causes a current to pass over the other wire when the stylus is moved laterally. These two motions are, at the receiving end of the line, made to operate on the needles of galvanometers, and the latter are by silk threads combined or connected with a delicately suspended ink tube, from which a minute stream of ink falls upon the strip of paper below it; the arrangement being such that the combined motions of the galvanometers so move the ink pen as to make it correspond to the motion of the stylus at the sending end. The apparatus is said to work very well, and it is expected that it will form a useful adjunct to the art of telegraphy. We present herewith a facsimile of writing done by this new instrument, which has been worked with success over a line of forty miles length. It is hardly probable that it can compete in rapidity with some of the telegraph instruments now in use; but for many purposes it is likely to become important, while in point of ingenuity it is certainly a great achievement, and the author is deserving of the highest credit.

Specimen of the writing telegraph of Mr. E. A. Cowper

A Rare Geological Specimen.

Rev. R. M. Luther, while absent in attendance upon the Missionary Convention, held in Addison, Vt., obtained through the kindness of the Rev. Mr. Nott a rare and curious geological specimen from the shores of Lake Champlain. It is a slab of limestone, about eleven inches long by six inches wide, which seems to be composed almost entirely of fossils. There is not half an inch square of the surface which does not show a fossil. There are many varieties, some of which have not been identified, but among those which have been are many remains of the *Trinucleus concentricus*, some specimens of *Petraia*, fragments of the *Orthis*, a number of *Discinae*, several well preserved specimens of *Leptænae*, and impressions of *Lingula*. The latter is the only shell which has existed from the first dawn of life until the present time without change. The specimens of existing *Lingula* are precisely similar to those found in the earliest geological formations. There are also in the slab several rare specimens of seaweed, remains of which are seldom found at so early an age in the geological history of the world. The slab belongs to the lower

Silurian formation, the first in which organic remains are found. It is probably from the Trenton epoch of that age. If geologists can be trusted, at the time the little animals, whose remains are thus preserved, were living, the only part of this continent which had appeared above the primeval ocean was a strip of land along the present St. Lawrence River and the northern shores of the great lakes, with a promontory reaching out toward the Adirondacks, and a few islands along what is now the Atlantic coast line.—*Bennington (Vt.) Banner*.

COWPER'S WRITING TELEGRAPH.

The most recent of the brilliant series of telegraphic marvels which has from time to time, and especially of late, engaged the attention of the world, is the "telegraphic pen" of Mr. E. A. Cowper, the well known engineer of Great George street, Westminster. This ingenious apparatus, which constitutes the first real telegraph, was publicly shown by its inventor at the meeting of the Society of Telegraph Engineers on Wednesday, February 26.

There had been no lack of copying telegraphs hitherto. We have Bakewell's, Casselli's, Meyer's, and D'Arincourt's, so recently tried at our General Post Office by Mr. Preece. All of these instruments telegraph an almost perfect copy of the writing or sketch submitted to them by means of synchronous mechanism. But the process is necessarily complex and slow; whereas by the new device a person may take the writing pencil in his hand, and himself transmit his message in the act of writing it.

The principle which guided Mr. Cowper to a solution of the problem which he has successfully overcome, is the well known mathematical fact that the position of any point in a curve can be determined by its distance from two rectangular co-ordinates. It follows, then, that every position of the point of a pencil, stylus, or pen, as it forms a letter, can be determined by its distance from two fixed lines, say the adjacent edges of the paper. Moreover it is obvious that if these distances could be transmitted by telegraph and recombined so as to give a resultant motion to a duplicate pen, a duplicate copy of the original writing would be produced. But inasmuch as the writing stylus moves continuously over the paper, the process of transmission would require to be a continuous one; that is to say, the current traversing the telegraph line, and conveying the distances in question (or what comes to the same thing, the up and down, and direct sidelong ranges of the stylus) would require to vary continuously in accordance with the range to be transmitted.

Mr. Cowper effects this by employing two separate telegraphic circuits, each with its own wire, battery, sending, and receiving apparatus. One of these circuits is made to transmit the up and down component writing of the pencil's motion, while the other simultaneously transmits its sidelong component. At the receiving station these two components are then recombined by a pantograph arrangement of taut cords, or levers, and the resultant motion is communicated to the duplicate pen at that place. The plan adopted by Mr. Cowper to transmit each continuously varying component is to cause the resistance of the circuit to vary very closely with the component in question. Fig. 5 shows how the apparatus is theoretically arranged for this purpose. P is

the writing style, which is held in the writer's hand in the ordinary way, while he shapes the letters one by one on paper pulled uniformly underneath by means of clockwork. To P are attached, at right angles, two arms, *a a*, one for each circuit; but as it is only necessary to consider one of the circuits, say that sending up and down motions, we will confine our attention for the present to the arm, *a*. One pole of the sending battery, B, is connected to the arm, *a*, the other pole being connected to earth. Now the arm, *a*, is fitted with a sliding contact at its free extremity, and as the pencil, P, is moved in writing, *a* slides lengthwise across the edges of a series of thin metal contact plates, C, insulated from each other by paraffined paper. Between each pair of these plates there is a resistance coil, C, and the last of these is connected through the last plate to the line, L. It will be seen that as *a* slides outward across the plates the current from the battery has to pass through fewer coils, since *a* short-circuits a number of coils proportional to its motion. But the fewer of these coils in circuit the stronger will be the current in the line; so that the extent of the mo-

tion of the arm, *a*, in the direction of its length, that is to say, the direct component of the motion of the pencil along the line of the arm, *a*, is attended by a corresponding change in the current traversing the line. If the pencil makes a long up and down stroke there will be a strong current in the line, if a short one there will be a weak current, and so on. A precisely similar arrangement is used to transmit the sidelong motion of the pencil along the line, L.

Fig. 5.

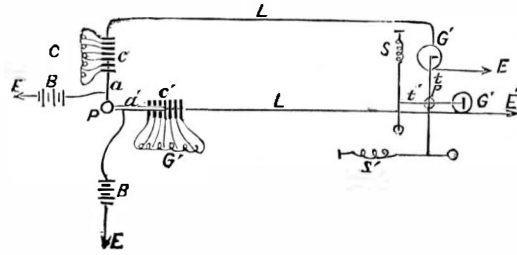

The current from the line, L, flows at the receiving station through a powerful galvanometer, G, to earth. The galvanometer has a stout needle, one tip of which is connected to a duplicate pen, P, by a thread, *t*, which is kept taut by a second thread stretched by a spring, *s*'. The current from the line, L, flows through a similar galvanometer, G', to earth. The needle of G' is also connected to the pen, P, by a taut thread, *t'*, stretched by means of the spring, *s*'. Now, since the needle of each of these galvanometers deflects in proportion to the strength of the current flowing through its coil, the points of these two needles keep moving with the varying currents. But since these currents vary the motions of the sending pen, the receiving pen controlled by the united movements of the needles will trace out a close copy of the original writing. We give on another page a facsimile of a sentence written by Mr. Cowper's telegraph.

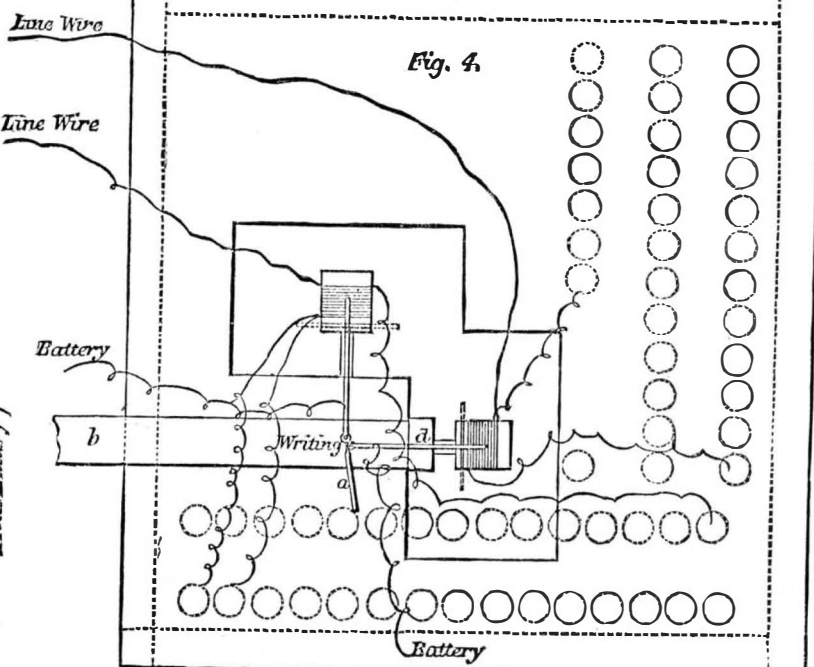
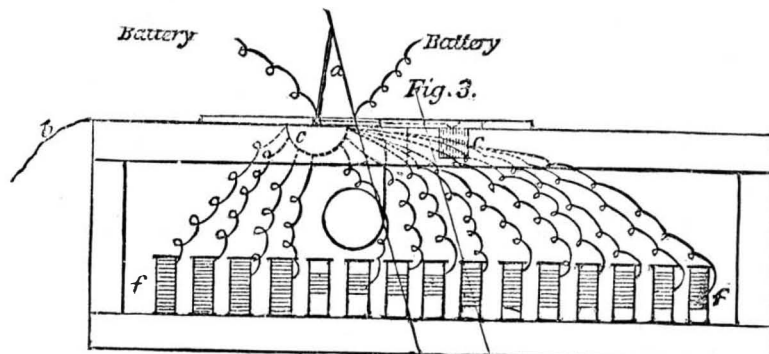
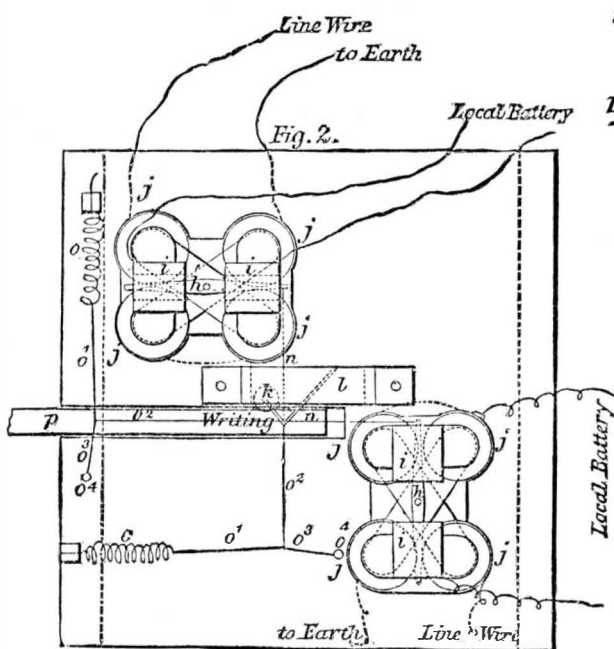
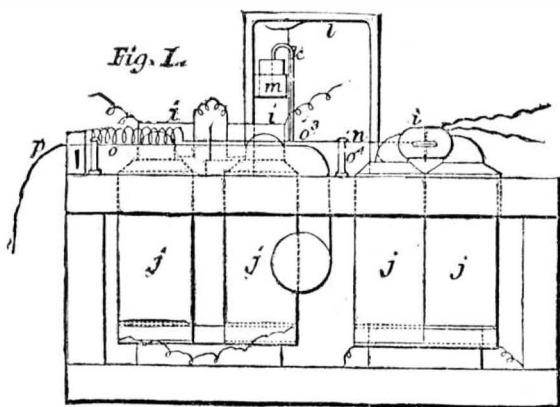

THE COWPER WRITING TELEGRAPH.

The receiving pen is a fine glass siphon, drawing off aniline ink from a small glass holder. There are thirty-two coils, C, in each circuit, with a corresponding number of contact plates, *c*, so as to get accuracy of working. A few Daniell's cells are sufficient to operate the apparatus, and writing has been already sent successfully over a line 40 miles in length. The writing may be received either of the same size or larger or smaller than the original, as the case may be. At present the writing must not be too hurried, that is, unless the characters are bold and well formed; but further improvement will, of course, quicken the working of the apparatus.

The engravings, Figs. 1 to 4, illustrate the actual apparatus. Fig. 4 is a plan of the sending instrument, with the writing pencil, *a*, the traveling paper, *b*, the light connecting rods or arms, *d* (which correspond to *a* in the theoretical diagram above), the series of metal contact plates over which these arms slide, the resistance coils connected to these plates, and the battery and line wires. It will be seen that each arm, *d*, is connected to its particular battery, and

each set of contact plates to its particular line. Fig. 3 is an elevation of the sending instrument, in which *a* is the pencil as before, *c c* the contact plates over which the arms, *d d*, slide, *f f* the coils, and *b* the traveling slip of paper.

Fig. 2 is a plan of the receiving instrument, in which *h h* are the light pivoted needles surrounded by coils of fine insulated copper wires, *i i*, and controlled in their zero position by the electro-magnets, *j j j j*, placed underneath, the whole forming a pair of galvanoscopes or current detectors, one for each line. It will be understood that the varying currents from the lines are allowed to flow through the coils, *i i*, so as to deflect the needles, and that the deflections of the needles follow, so to speak, the variations of the currents. The electro-magnets are magnetized by a local battery; permanent magnets might, however, take their place with a gain in simplicity.

Now the writing pen, *k*, is connected to the nearest tip of the needle, *h*, of each galvanoscope by threads, *n n*, which are kept taut by the fibers, *o₁ o₂ o₃*, the springs, *o*, and the pins, *o₄*. In this way the motions of the needles are recombined in the motion of the duplicate pen upon the paper, *p*.

Fig. 1 is an elevation of the receiving instrument, in which *i i* are the coils as before, *j j j j* the controlling electro-magnets, *k* is the writing siphon dipping with its short leg into the ink well, *m*, and *l* is the bridge from which the writing siphon is suspended by means of a thread and spring. The long leg of the siphon reaches down to the surface of the paper, *p*, which is pulled along beneath it in contact with the film of ink filling the point of the tube. When the siphon is at rest its point marks a zero line along the middle of the paper, but when the receiver is working, the siphon point forms each letter of the message upon the paper as it passes.—*Engineering*.

ALUMINUM.

The splendid exhibit of the French aluminum manufactur-

ers at the late Exhibition has again called attention to that metal, which is so admirably adapted to many purposes on account of its great lightness and its stability under the influence of the atmosphere. While aluminum industry has heretofore been thought to be confined to France solely, we are now told by Mr. C. Bamberg, in the Annual Report of the Society of Berlin Instrument Makers, that for some years past aluminum has been extensively manufactured in Berlin.

Three firms especially (Stückradt, Häcke, and Schultze) are engaged in this branch of industry.

The articles manufactured principally are nautical instruments, as sextants, compasses, etc. The German navy is

supplied throughout with aluminum instruments. As a proof of the superiority of German aluminum, it may here be mentioned that the normal sets of weights and balances used by the International Commission for the regulation of weights and measures, which lately was in session at Paris, were obtained from Stückradt, in Berlin, and not from any of the firms at Paris, the reputed seat of aluminum industry.

Aluminum is, in Berlin, generally used pure, and cast pieces only are composed of aluminum containing about 5 per cent of silver.

Nevertheless the use of aluminum will remain limited, even in case the cost of manufacturing it could be materially reduced, until some method shall have been discovered by which aluminum may be soldered.

This difficulty has, in spite of all efforts, not yet been overcome, and for some purposes, to which the metal would otherwise be well adapted, it remains so far unavailable. Here then is a chance for some ingenious mind.

AN IMPROVED DOOR BOLT.

The accompanying engraving represents, in perspective and in section, an improved door bolt, recently patented by Mr. Thomas Hoesly, of New Glarus, Wis.

The principal features of this bolt will be understood by reference to the engraving. On the plate or body are cast two loops or guides for the bolt, and the plate is slotted under the bolt, and a lug projects into the slot and bears against a spring contained by a small casing riveted to the back of the plate. The end of the bolt is beveled, and its operation is similar to that of the ordinary door latch. Two handles are provided, one of which is of sufficient length to reach through the door, and a pawl or dog accompanies the

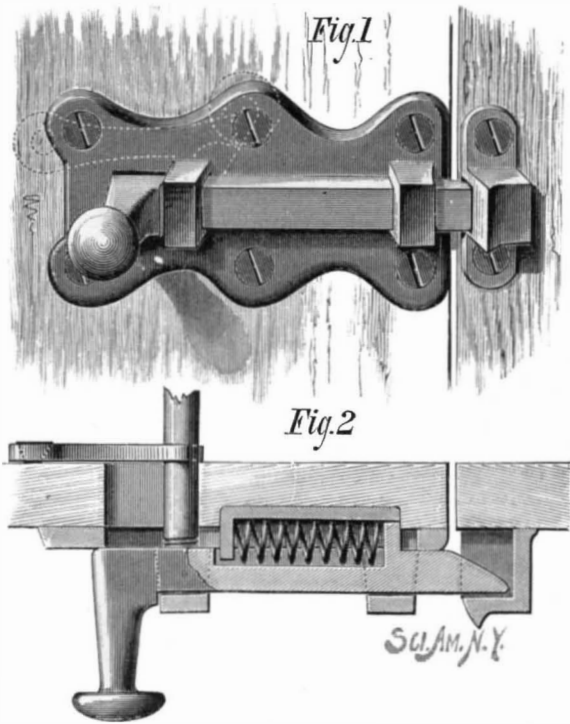

HOESLY'S DOOR BOLT.

bolt, which may be attached to the door with a single screw, and is to be used in locking the door. The bolt is very simple and strong, suitable for shops, out-buildings such as barns, stables, etc., and some of the doors of dwellings.

Further information may be obtained by addressing the inventor, as above.

Chimney Flues.

Messrs. W. H. Jackson & Co., of this city, whose long experience in treating refractory flues gives weight to their opinion, communicate to the *American Architect* the following useful information:

To secure a good draught the chimney should be of sufficient size, should be carried up above surrounding objects, should be as straight as possible throughout its length, and should be as smooth as possible inside, to avoid friction. As a draught is caused by unequal temperatures, the chimney should be so arranged as to avoid a rapid radiation of heat. If in an exterior wall there should be at least 8 inches of brickwork between the flue and the exterior surface. For country houses it is much better to have the chimneys run up through the interior, as the flue is more easily kept warm, and the heat that is radiated helps to warm the house. The most frequent cause of a "smoky chimney" is the insufficient size of the flue for the grate or fireplace connected therewith. The flue should not be less than one eighth the capacity of the square of the width and height of the grate or fireplace. That is, if the grate has a front opening 20 inches wide and 26 inches high, the flue should be 8 in. x 8 in.; or, with an opening 36 inches wide and 32 inches high, the flue should be 12 in. x 12 in.; and, to get the best result, the opening into the flue from the grate or fireplace should be of a less number of square inches than the square of the flue, and never larger, as no more air should be admitted at the inlet than can be carried through the flue. Where there is more than one inlet to the same flue, the sum of all the inlets should not more than equal the size of the flue. A number of stoves may be connected with the same flue, one above another, if this rule is observed.

A square flue is better than a narrow one, as in two flues containing the same number of square inches the square flue would have the smallest amount of wall surface,

and consequently less friction for the ascending currents, and less absorption of heat by the walls. Chimneys should be closely built, having no cracks nor openings through which external air may be drawn to weaken the draught. If they could be made throughout their length as impervious to air as a tube of glass, with interior surface as smooth, one cause of smoky chimneys would be removed. A downward current of air is frequently caused by some contiguous object higher than the chimney, against which the wind strikes. This higher object may sometimes be quite a distance from the chimney, and still affect it badly. A good chimney top constructed to prevent a down draught will remedy this difficulty. Each grate or fireplace should have a flue to itself. Under very favorable conditions, two grates or fireplaces might be connected with the same flue, but it is not a good plan. We have known grates and fireplaces connected with two flues, where they have been built under a window for instance, and, owing to there being insufficient room for a flue of suitable size, a flue has been run up on each side of the window. This is a very bad plan, and never can work well; it requires too much heat to warm both flues, and if the room in which the grate or fireplace is situated should be pretty close, so that there was no other entrance for air, there is danger that it would circulate down one flue and up the other, forcing smoke out of the fireplace into the room.

IMPROVED FURNACE FOR BURNING GARBAGE.

The refuse matter and garbage of large cities is in the main composed of animal and vegetable offal of the kitchens; of the sweepings of warehouses, manufactories, saloons, groceries, public and private houses; of straw, sawdust, old bedding, tobacco stems, ashes, old boots, shoes, tin cans, bottles, rags, and feathers; dead cats, dogs, and other small animals; of the dust and sweepings of the streets, the condemned fruit, vegetables, meat, and fish of the markets, all of which compose a mass of the most obnoxious and unhealthy matter that can be deposited near human habitations.

The inventor of the furnace shown in the accompanying engravings aims to produce a change of form and of chemical nature and a great reduction in bulk of all such refuse and garbage within the limits of the city where it accumulates, without screening, separating, preparing, or mixing, without the expense of using other fuel, without any offensive odors being generated in the operation, and to produce an entirely unobjectionable residuum or product that may be made useful.

As a rule organic matter largely preponderates in the refuse, being as high in some instances as 94 per cent. There is always more than enough to generate sufficient heat to fuse the earthy or inorganic portion, which is mainly composed of sand, clay, and the alkalis from the coal and vegetable ashes, etc.

By producing a high degree of heat in the combustion of the organic portion of the refuse with a forced blast or forced draught, the non-combustible elements are fused, and form a vitreous slag, which is entirely inodorous and unobjectionable, and which may be utilized for many purposes.

The upper section or cone of the consuming furnace is built

nace is closed with an iron plate, provided with a circular opening, through which the hopper enters the top of the furnace.

At the left in the larger engraving is seen an elevator, operated by a steam engine, for conveying the garbage and refuse to a platform, whence it is projected into the furnace by an inclined plane or chute.

Gas or smoke conductors convey the gas from the top of the furnace to the furnace of the boiler and to the heating oven, where it is used in heating air, which is conveyed through the iron pipes passing through the heating oven into a wind box, from which it enters the furnace at several points near the bottom by means of the tuyere pipes.

The consumption of the garbage is effected near the bottom

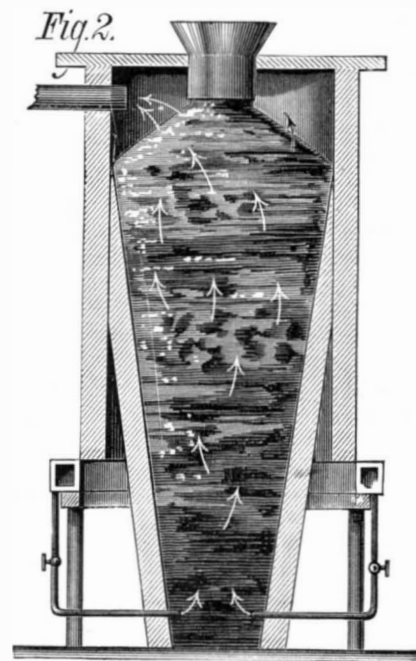

SECTION OF FURNACE.

of the furnace, where the air is forced in, and is continued as long as the blast is applied, and while burning at the base it is continually sinking down at the top, so that it is necessary to keep filling all the time. The odoriferous gases and the hot products of such combustion are forced upward through the superimposed mass, and escape to the fires of the boiler and heating oven, and, being largely composed of carbonic oxide and the hydrocarbon gases distilled from the animal and vegetable offal of the garbage, are thoroughly consumed; and it is said that by this means not only are all the offensive odors destroyed, but the heat generated is utilized for making steam and heating the air used for blast.

The refuse in its descent through the high furnace is exposed to the drying action of the hot gases of distillation and the hot products of combustion, its temperature increasing in its descent the nearer it approaches the tuyeres, and becomes completely desiccated and combustible when it reaches the blast. The high heat in this way obtained by the combustion of the organic portion melts all of the inorganic portion, forming a vitreous slag or glass, which may be allowed to run continuously, or by closing the tap may be allowed to accumulate, and can be drawn off at intervals. If there is an adequate supply of clay and sand in the refuse to combine with the ashes, the slag will run hot and free. The combination of siliceous or alumina and an alkali in proper portions always yields a fusible, easy-running compound.

The molten slag, as it runs from the furnace, may be discharged into tanks of cold water, which will pulverize or granulate it, making it like fine sand, or as it pours over a runner, through which it flows, if struck with a forcible air or steam blast it will be spun into fine thread-like wool.

The furnace once lighted and started may be kept running day and night continuously for days, months, or years, if desired; but if it becomes necessary to stop at any time, the tuyere pipes may be removed and the holes all stopped with clay, so as to entirely shut off the supply of air, and it will then hold in fire for many days, and will be in readiness to start again at any time the pipes are replaced and the blast turned on.

This furnace is the invention of Mr. Henry R. Foote, of Stamford, Conn.

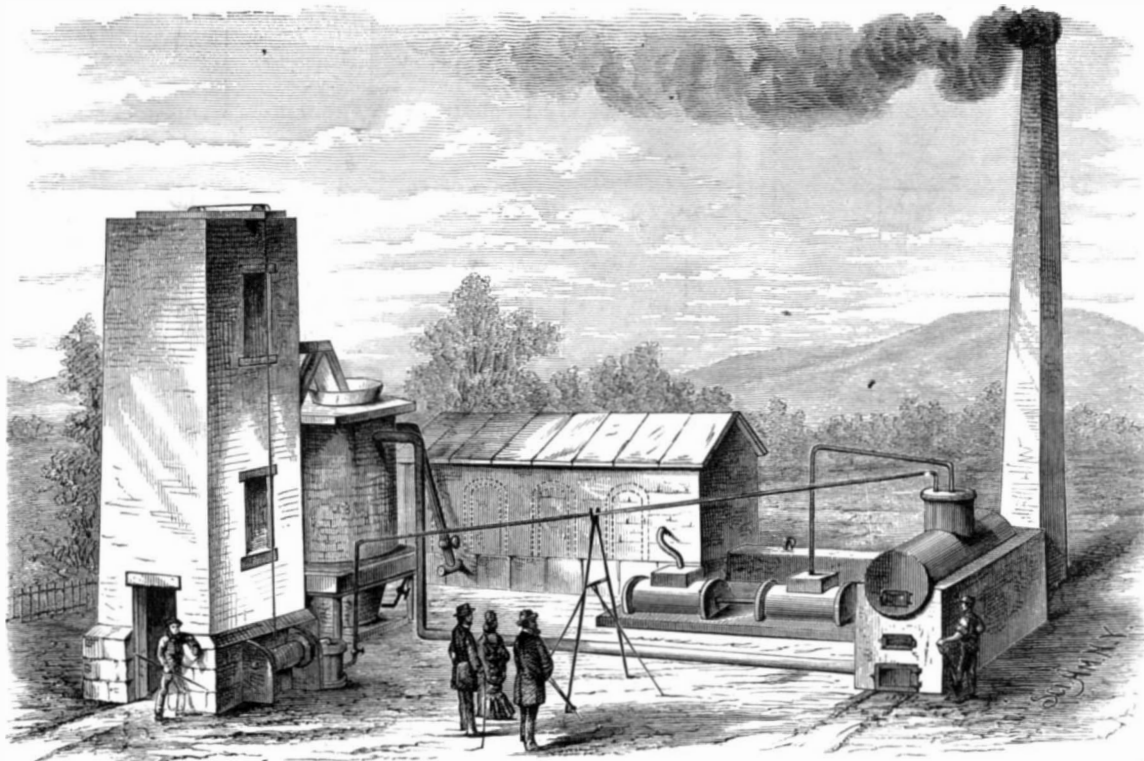

Fig. 1.—FOOTE'S FURNACE FOR BURNING GARBAGE.

of boiler iron, and lined with fire brick resting upon an iron plate, which is supported by iron columns.

The hearth is made of fire brick, and is in the form of an inverted cone, being smaller at the bottom and larger at the top, as shown in Fig. 2.

The sides of the hearth are perforated near the bottom with arches for the tuyeres or blast pipes, and also in front for the special blast pipe and the tapping hole. The top of the fur-

AN ANCIENT GREEK VASE.

The vase shown in the accompanying engravings must not be classed with ordinary ceramic ware, as it is a veritable work of art. It is the celebrated cup of Arcesilaus, which is preserved in the collection of the library of Richelieu street after having figured in the Durand Museum. It was found at Vulsei, in Etruria. It was made by a potter of Cyrene, the capital of Cyrenaica, founded by Greeks from the island of Thera. It is remarkable that Cyrene, removed from the center of Grecian manufacture, should possess a manufactory of painted vases from which have come so many works of art. The traveler, Paul Lucas, discovered in the necropolis of Cyrene, in 1714, many antique vases, both in the tombs and in the soil. One of them is still preserved in the Museum at Leyden. The Arcesilaus, who is represented on this vase, is not the celebrated skeptical philosopher of that name; it is Arcesilaus, King of Cyrenaica, who was sung by Pindar, and who was vanquished in the Pythian games under the 80th Olympiad (458 years B.C.).

The height of this vase is 25 centimeters, its diameter 28 centimeters. The paste is very fine, of a pale red. It is entirely coated with a black groundwork, which has been generally re-covered with a yellowish white clay, baked on.

According to M. Brongniart, this piece has been subjected to the baking process at least two or three times, thus indicating that the ceramic art had made considerable progress in Cyrene even at that remote epoch.

The following description of this vase is given in the catalogue of the Durand Museum: The King Arcesilaus is seated under a pavilion upon the deck of a ship. His head is covered with a kind of hat with a large brim, and his hair hangs down upon his shoulders. He is clothed in a white tunic and embroidered cloak or mantle, and he carries a scepter in his left hand; under his seat is a leopard, and his right hand he holds toward a young man, who makes the same gesture, and he is weighing in a large scale assafœtida, which is being let down into the hold of the ship. We know that he deals with assafœtida because one of the personages (the one who lifts up his arm toward the beam of the scale) holds in his right hand something resembling that which is in the scale, and the Greek word traced near it signifies "that which prepares *silphium*." Assafœtida, the resinous matter of the silphium, is used largely by the Greeks in the preparation of their food. The Orientals to-day make frequent use of it and call it the delight of the gods; while in Europe, because of its repulsive odor, it has long been designated as *stircus diaboli*.

Snow-Raised Bread.

Somebody thinks he has discovered that snow, when incorporated with dough, performs the same office as baking powder or yeast. "I have this morning for breakfast," says a writer in the *English Mechanic*, "partaken of a snow-raised bread cake, made last evening as follows: The cake when baked weighed about three quarters of a pound. A large tablespoonful of fine, dry, clean snow was intimately stirred with a spoon into the dry flour, and to this was added a tablespoonful of caraways and a little butter and salt. Then sufficient cold water was added to make the dough of the proper usual consistence (simply stirred with the spoon, not kneaded by the warm hands), and it was immediately put into a quick oven and baked three quarters of an hour. It turned out both light and palatable. The reason," adds the writer, "appears to be this: the light mass of interlaced snow crystals hold imprisoned a large quantity of condensed atmospheric air, which, when the snow is warmed by thawing very rapidly in the dough, expands enormously and acts the part of the carbonic acid gas in either baking powder or yeast. I take the precise action to be, then, not due in any way to the snow itself, but simply to the expansion of the fixed air lodged between the interstices of the snow crystals by application of heat. This theory, if carefully followed out, may perchance give a clew to a simple and perfectly innocuous method of raising bread and pastry." And stop the discussion as to whether alum in baking powders is deleterious to health or otherwise.

NEW AGRICULTURAL INVENTIONS.

An improved gate, invented by Messrs. P. W. McKinley and George L. Ellis, of Ripley, O., is designed for general use. It is operated by cords and pulleys, and can be opened without dismounting from the horse. It is constructed so that it cannot sag, and is not liable to get out of order.

An improved apparatus for pressing tobacco has been patented by Mr. F. B. Deane, of Lynchburg, Va. It consists mainly in the construction of a suspended jack, arranged to travel over a row of hogsheads, so that a single jack gives successively to each hogshead the desired pressure.

An improved combined harrow and corn planter has been patented by Mr. M. McNitt, of Hanover, Kan. In this machine the opening, pulverizing, planting, and covering teeth are combined with a single frame.

A machine, which is adapted to the thrashing and cleaning of peas and seeds, and for cleaning all kinds of grain, has been patented by Mr. J. J. Sweatt, of Conyersville, Tenn.

Mr. Amos M. Gooch, of Farmington, W. Va., has patented an improved corn planter, which drops the fertilizer simultaneously with the seed, and is provided with a device for pressing the soil around the seed, leaving over the seed a portion of loose earth.



Fig. 2.—TOP OF GREEK VASE.

An improved machine for harvesting cotton has been patented by R. H. Pirtle, of Lowe's, Ky. This machine carries two vertical cylinders armed with teeth or spurs, and two inclined endless belts provided with teeth. The teeth of the cylinders and the belts remove the cotton from the plants, and deliver it to a receptacle carried by the machine.

Messrs. Julius Fern and Samuel Bligh, of Oneonta, N. Y., have patented an improved power for churning and other purposes where little power is required. It consists in the combination of a drum and weight, a train of gearing, and a pallet wheel arranged to oscillate a balanced beam.

An improvement in the class of feed cutters in which two or more knives work between parallel bars attached to the cutter box, has been patented by Messrs. J. N. Tatum and

from practical observation and also theoretically from the relation which must exist between the two eyes and the colors of the spectrum. His third advice is to give preference to small volumes which can be held in the hand, which obviates the necessity of the book being kept fixed in one place, and the fatigue resulting from accidental images. Lastly, M. Javel advises the avoidance of too long lines, and therefore he prefers small volumes, and for the same reason those journals which are printed in narrow columns. Of course every one knows that it is exceedingly injurious to read with insufficient light, or to use too small print, and other common rules. M. Javel concludes by protesting against an invidious assertion which has recently been made "in a neighboring country," according to which the degree of civilization of a people is proportional to the number of the short-sighted shown to exist by statistics; the extreme economy of light, the abuse of reading to the detriment of reflection and the observation of real facts, the employment of Gothic characters and of a too broad column for books and journals, are the conditions which, M. Javel believes, lead to myopia, especially if successive generations have been subjected to these injurious influences.

Phosphorescence.

M. Nuesch records, in a recent number of the *Journal de Pharmacie*, some curious observations regarding luminous bacteria in fresh meat. Some pork cutlets, he found, illuminated his kitchen so that he could read the time on his watch. The butcher who sent the meat told him the phosphorescence was first observed in a cellar, where he kept scraps for making sausages. By degrees all his meat became phosphorescent, and fresh meat from distant towns got into the same state. On scratching the surface or wiping it vigorously, the phosphorescence disappears for a time; and the butcher wiped carefully the meat he sent out. All parts of the animal, except the blood, acquired the phenomenon over their whole surface. The meat must be fresh; when it ceases to be so, the phosphorescence ceases, and *Bacterium termo* appear. None of the customers had been incommoded. It was remarked that if



Fig. 1.—ANCIENT GREEK VASE.

R. C. Harvey, of Danville, Va. The improvement consists in arranging the knives so that one begins and finishes its cut in advance of the other.

Mr. William Bradberry, of Darrown, O., has invented an improvement in reciprocating churns. The aim of this inventor is to utilize the resistance of the milk as a source of power. To accomplish this a peculiar combination of mechanism is required, which cannot be clearly described without an engraving.

a small trace of the phosphorescent matter were put at any point on the flesh of cats, rabbits, etc., the phosphorescence gradually spread out from the center, and in three or four days covered the piece; it disappeared generally on the sixth or seventh day. Cooked meat did not present the phenomenon, but it could be had in a weak manner, from cooked albumen or potatoes. No other butcher's shop in the place was affected. The author is uncertain whether to attribute the complete disappearance of the phenomenon to the higher temperature of the season, or to phenic acid, or to fumigation with chlorine.

The Charms of Natural Science.

The Earl of Derby, in an address at the Edinburgh University, said: "Of the gains derivable from natural science I do not trust myself to speak; my personal knowledge is too limited, and the subject is too vast. But so much as this I can say—that those who have in them a real and deep love of scientific research, whatever their position in other respects, are so far at least among the happiest of mankind. . . . No passion is so absorbing, no labor is so assuredly its own reward (well that it is so, for other rewards are few); and they have the satisfaction of knowing that, while satisfying one of the deepest wants of their own natures, they are at the same time promoting in the most effectual manner the interests of mankind. Scientific discovery has this advantage over almost every other form of successful human efforts, that its results are certain, that they are permanent, that whatever benefits grow out of them are world-wide. Not many of us can hope to extend the range of knowledge in however minute a degree; but to know and to apply the knowledge that has been gained by others, to have an intelligent appreciation of what is going on around us, is in itself one of the highest and most enduring of pleasures."

THE VESUVIUS RAILWAY.—The Italian Ministry of Public Works, in union with the Ministry of Finance and the Prefecture of Naples, has issued the concession for the construction of the Vesuvius Railway. The line will run along that part of the mountain which has been proved, after the experience of many years, to be the least exposed to the eruptions. The work is to be commenced immediately, and it is believed that it will come into use during the present year. A sufficient number of carriages are being built to convey 600 persons during the day. The line is to be constructed upon an iron bridge, built after a patented system.

The Pottery Tree.

Among the various economic products of the vegetable kingdom, scarcely any hold a more important place than barks, whether for medicinal, manufacturing, or other purposes. The structure and formation of all barks are essentially very similar, being composed of cellular and fibrous tissue. The cell contents of these tissues, however, vary much in different plants; and, for this reason, we have fibrous or soft, woody, hard, and even stony barks. To explain everything which relates to the structure of bark would lead us into long details which our space will not permit. Briefly stated, the bark of trees (considering, now, those of our own climate) consists of three layers. The outermost, called the "cortical," is formed of cellular tissue, and differs widely in consistency in different species; thus, in the cork oak, which furnishes man with one of his most useful commercial products, the cortical layer acquires extraordinary thickness. The middle layer, called the "cellular" or "green bark," is a cellular mass of a very different nature. The cells of which it is composed are polyhedral, thicker, and more loosely joined, and filled with sap and chlorophyl. The inner layer (next the wood), called the "liber," consists of fibers more or less long and tenacious. It is from the liber that our most valuable commercial fibers are obtained. In some plants the fibrous system prevails throughout the inner bark; but what we wish to refer to more particularly at present is a remarkable example of the harder and more silicious barks, and which is to be found in the "Pottery Tree" of Para. This tree, known to the Spaniards as *El Caouta*, to the French as *Bois de Fer*, to the Brazilians as *Caraipe*, is the *Moquilea utilis* of botanists, and belongs to the natural order *Ternstroemiaceae*. It is very large, straight, and slender, reaching a height of 100 feet before branching; its diameter is from 12 to 15 inches; and its wood is exceedingly hard from containing much flinty matter. Although the wood of the tree is exceedingly sound and durable, the great value of the tree to the natives exists in the bark for a purpose which, to say the least, is a novel one in the application of barks—that of the manufacture of pottery. The Indians employed in the manufacture of pottery from this material always keep a stock of it on hand in their huts for the purpose of drying and seasoning it, as it then burns more freely, and the ashes can be gathered with more ease than when fresh. In the process of manufacturing the pottery the ashes of the bark are pow-

dered and mixed with the purest clay that can be obtained from the beds of the rivers; this kind being preferred, as it takes up a larger quantity of the ash, and thus produces a stronger kind of ware. Though the proportions of ash and clay are varied at the will of the maker, and according to

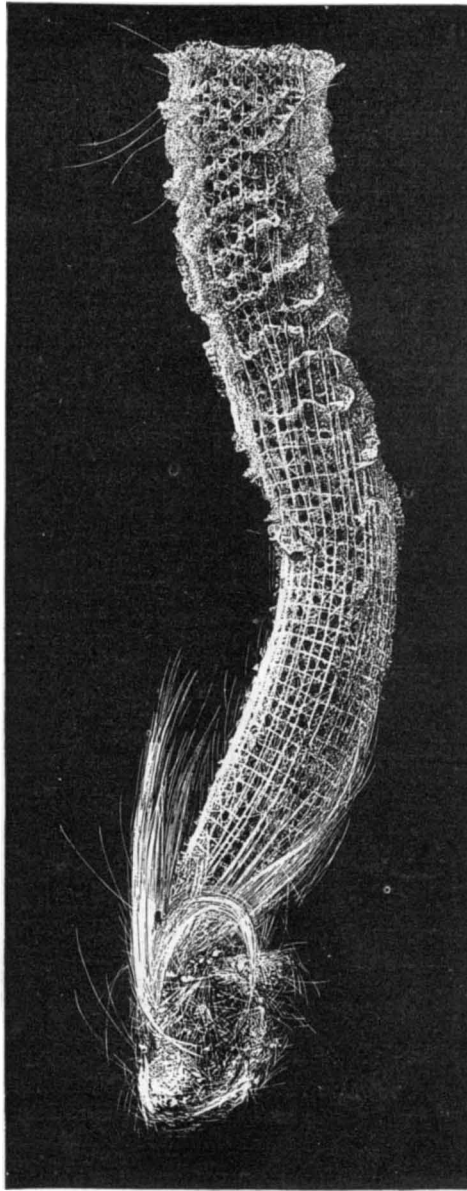

Fig. 1.—SPRINKLING POT SPONGE.—(*Eucleptella aspergillum*.)

dered and mixed with the purest clay that can be obtained from the beds of the rivers; this kind being preferred, as it takes up a larger quantity of the ash, and thus produces a stronger kind of ware. Though the proportions of ash and clay are varied at the will of the maker, and according to

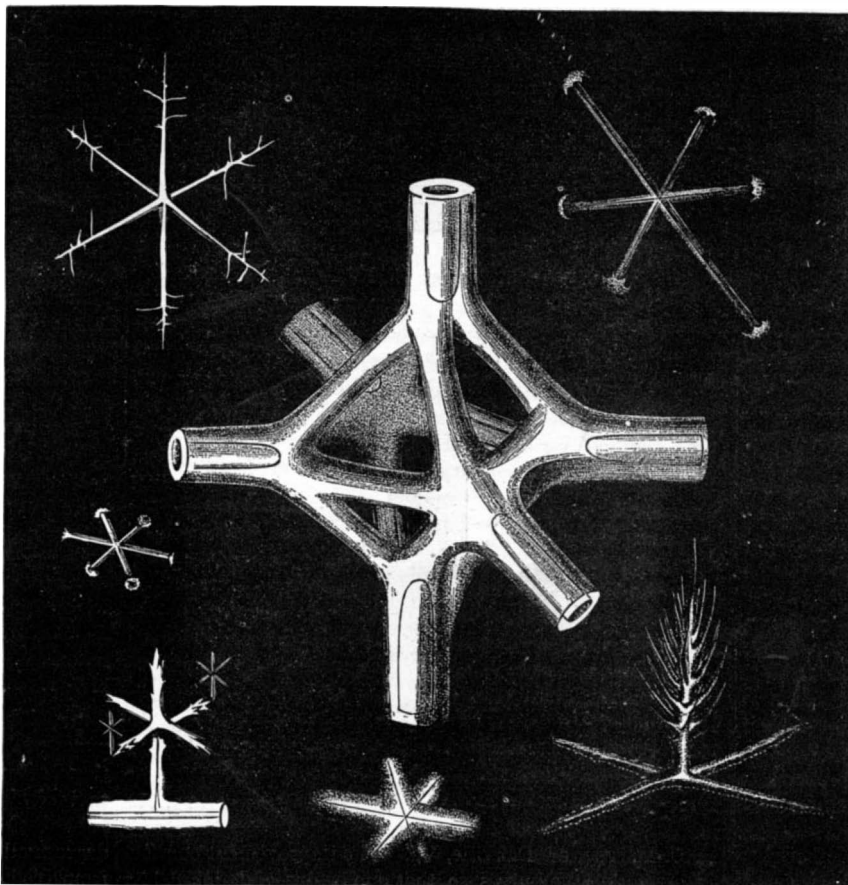

Fig. 2.—SPONGE CRYSTALS MAGNIFIED.

dered and mixed with the purest clay that can be obtained from the beds of the rivers; this kind being preferred, as it takes up a larger quantity of the ash, and thus produces a stronger kind of ware. Though the proportions of ash and clay are varied at the will of the maker, and according to

dermis; when fresh, it cuts somewhat similar to a soft sandstone, but when dry, it is very brittle and flint like, and often difficult to break. On examination of a section under the microscope, all the cells of the different layers are seen to be more or less silicated, the silicium forming in the cells when the bark is still very young. In the inner bark the flint is deposited in a very regular manner, the particles being straight and giving off branches at right angles; that of the porous cells of the bark, however, is very much contorted, and ramifies in all directions. In the best varieties of the tree, those growing in rich and dry soil, the silicium can be readily detected by the naked eye; but to test the quality of the various kinds of bark, the natives burn it and then try its strength between their fingers; if it breaks easily it is considered of little value, but if it requires a mortar and pestle to break, its quality is pronounced good. From an analysis of this singular bark, that of old trees has been found to give 30.8 per cent of ash, and that of young 23.30 per cent. Of the different layers of old bark, the outer gave 17.15 per cent, the middle 37.7, and the inner 31. The wood of the tree, in comparison with the bark, is relatively poor in silicium, the duramen of an old tree giving only 2.5 per cent of silicium.

GLASS SPONGES.

The natural history of sponges had, up to the middle of this century, been comparatively neglected. Until 1856, when Lieberkuhn published his treatise on sponges, very little or nothing had been written on the subject. Later, Haeckel did much to determine their exact nature, and it is now universally admitted that sponges form one of the connecting links between the animal and the vegetable kingdom.

Sponges, generally considered, consist of fine porous tissue, covered, during life, with viscid, semi-liquid protoplasm, and are held in shape and strengthened by a more or less rigid skeleton, consisting chiefly of lime or silica. The tissue consists of a very fine network of threads, formed probably by gradual solidification of the threads of protoplasm. The inorganic skeleton is formed by larger and smaller crystals and crystalline threads. In the various families of sponges the quantity of inorganic matter varies greatly; some sponges are nearly devoid of an inorganic skeleton, while other families consist chiefly of lime or silica, the organic tissue being only rudimentarily developed.

As observed in their natural state, sponges are apparently lifeless. When, however, a live sponge is placed in water containing some finely powdered pigment in suspension, it will be noticed that in regular, short intervals water is absorbed through the pores of the tissue and ejected again through larger openings, which are called "osculæ." Following up these into the interior, we find them divided into numerous branches, the walls of which are, under the microscope, found to be covered with minute cells, fastened at one end only and oscillating continually. By means of these cells the sponge receives its nourishment.

Sponges with very rigid inorganic skeletons may be divided into two classes—calcareous and silicious—according to whether the skeleton is chiefly composed of lime or silica.

Our engravings represent two species of the latter kind, which are, on account of the peculiar appearance of their skeleton, called glass sponges.

Fig. 1 represents the "sprinkling pot sponge," *Eucleptella aspergillum*. It is generally found in very deep water throughout the Pacific. Specimens were found over fifty years ago, but, as they had to be brought up from depths between 500 and 800 fathoms, they remained very scarce and sold at fabulous prices.

The skeleton is formed by small crystals and long threads of vitreous silica, cemented together, during life, by protoplasm. They are arranged in longitudinal and annular bands so as to form a long curved cylinder, about nine to twelve inches long, the walls of which are about one inch in thickness. The threads and bands are interwoven with the greatest regularity, and when the skeleton is freed from the adhering organic matter, it looks extremely beautiful.

The mode in which the intersecting bunches of crystals are connected is shown in Fig. 2. The upper end of the cylinder is closed by a perforated cover, which probably has given rise to the name of the sponge. The upper portion of the cylinder is surrounded by a few irregular, annular masses of organic tissue, which adheres loosely only to the skeleton. The lower end is formed by a bunch of long threads, rooting firmly in the ground.

Up to about ten years ago the price of specimens of this sponge was very high. At that time, however, a colony of *Eucleptellas* was found near the cities of Cebu and Manila, in the East Indies, in a depth not exceeding 100 fathoms, and since they have appeared in

larger quantities in the market. It is remarkable that, contrary to their habits, these organisms have immigrated into regions to which they were totally unaccustomed. Yet it must be regarded as a greater curiosity that they have been accompanied to their new abode by a few animals living

in equally deep water and never met with before at depths less than three or four hundred fathoms. Among these animals is a *Phormosoma* (water hedgehog), noted for its long spines.

Glass sponges are not confined to tropical regions. They are met with in latitudes as high as the Färöe Islands, where the beautiful *Holténia Carpenteria* abounds. It is represented in Fig. 3. Its cup-shaped skeleton is similar in structure to that of the *Eucleptella*; numerous crystalline needles protrude from the surface of the upper part. Lately some specimens of *Holténia* have been found on the coast of Florida.

Glass sponges serve as dwellings for numerous animals, especially crustaceæ. A small shrimp inhabits the tubes of the *Eucleptella*, a male and a female generally living together. They are shut up as in a prison in their crystalline home, as they are generally too large to pass through the meshes formed by the bundles of crystals. It was formerly believed that these skeletons had actually been built by the shrimps, and we can find no explanation for this curious circumstance, other than that the shrimps entered these habitations while very small and became too large to leave them.

Plants Protected by Insects.

Mr. Francis Darwin, in a lecture on "Means of Self-Defense among Plants," delivered lately at the London Institution, said that one of the most curious forms of defense known is afforded by a recently discovered class of plants, which, being stingless themselves, are protected by stinging ants, which make their home in the plant and defend it against its enemies. Of these the most remarkable is the bull's-horn acacia (described by the late Mr. Belt in his book "The Naturalist in Nicaragua"), a shrubby tree with gigantic curved thorns, from which its name is derived. These horns are hollow and tenanted by ants, which bore a hole in them, and the workers may be seen running about over the green leaves. If a branch is shaken the ants swarm out of the thorns and attack the aggressor with their stings. Their chief service to the plant consists in defending it against leaf-cutting ants, which are the great enemy of all vegetation in that part of America. The latter form large underground nests, and their work of destruction consists in gathering leaves, which they strip to form heaps of material, which become covered over with a delicate white fungus, on which the larvæ of the ants are fed, so that literally they are a colony of mushroom growers. The special province of the little stinging ants, which live in the thorns of the acacia, is, therefore, to protect the leaves of the shrub from being used by the leaf-cutters to make mushroom beds. Certain varieties of the orange tree have leaves which are distasteful to the leaf-cutters, this property of the leaves thus forming a means of defense. Other plants are unaccountably spared by them—grass, for example, which, if brought to the nest, is at once thrown out by some ant in authority. The bull's-horn acacia, in return for the service rendered by the stinging ants, not only affords them shelter in its thorns, but provides them with nectar secreted by glands at the base of its leaves, and also grows for them small yellow pear-shaped bodies, about one twelfth of an inch in length, at the tip of some of its leaflets, which they use as food. These little yellow bodies are made up of cells containing protoplasm rich in oil, and afford the insects an excellent food. When the leaf unfolds, the ants may be seen running from one leaflet to another, to see if these little yellow bodies are ripe; and if they are ready to be gathered they are broken up by the ants and carried away to the nest in the thorn. Several small birds, also, build their nests in the bull's horn acacia, thus escaping from a predatory ant which is capable of killing young birds. The trumpet tree, another plant of South and Central America, is also protected by a standing army of ants; and, like the above mentioned acacia, grows for its protectors small food bodies containing oil, but instead of secreting nectar in its leaves it harbors a small insect (*coccus*), whose sweet secretion is much relished by the ants. Dr. Beccari mentions an epiphytal plant growing on trees in Borneo, the seeds of which germinate, like those of the mistletoe, on the branches of the tree; and the seedling stem, crowned by the cotyledons, grows to about an inch in length, remaining in that condition until a certain species of ant bites a hole in the stem, which then produces a gall-like growth that ultimately constitutes the home of the ants. If the plant is not fortunate enough to be bitten by an ant it dies. These ants, then, protect their plant home by rushing out fiercely on intruders, and thus are preserved the sessile white flowers which, in this plant, are developed on the tuber like body.

ADVANCE IN IRON.—At a meeting of the Philadelphia Iron Merchants' Association, March 11, prices of all descriptions of merchant iron were advanced fully 5 per cent.

The Aneroid Barometer.

The aneroid barometer was invented by M. Vidi, of Paris. It consists essentially of a circular box, the face of which is made of thin elastic metal, rendered more elastic by being stamped and pressed into concentric circular wave-like corrugations. This box is nearly exhausted of air, and its elastic face supports the pressure of the atmosphere, and yields to it with elastic resistance in proportion to the amount of pressure. Thus, if the atmospheric pressure increases, the face is pressed inward; if atmospheric pressure diminishes, the elastic reaction of the metal moves the face outward. These movements are communicated to an index by suitable and very delicate mechanism, and registered in largely magnified dimensions, by the movements of this index upon the face of the dial.

Aneroid barometers are now made of pocket size, compensated for temperature, and with double scales, one reading the height of the barometer column, the other the elevation obtained. I have, says Prof. W. M. Williams, used one of these during many years, and find it a very interesting traveling companion. It is sufficiently sensitive to indicate

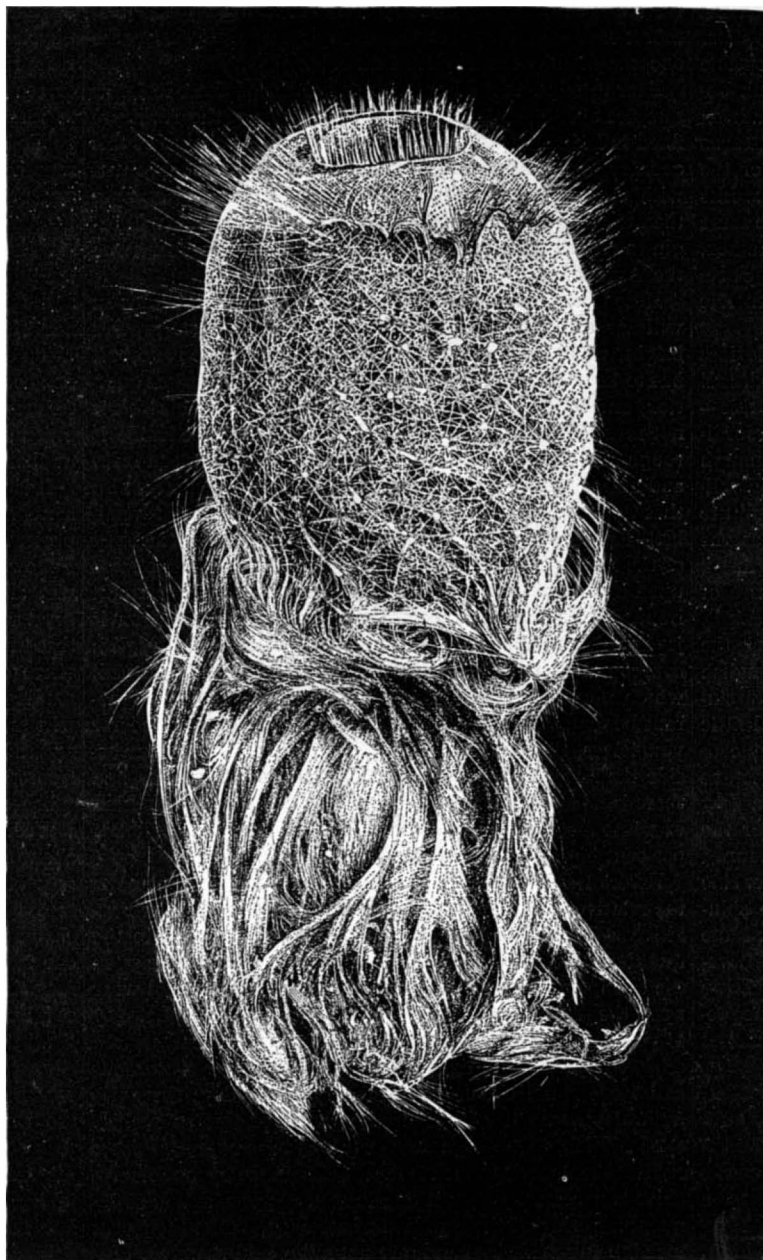

Fig. 3.—HOLTÉNIA CARPENTERIA.

the ascent from the ground floor to the upper rooms of a three-storied house, or to enable the traveler sitting in a railway train to tell, by watching its face, whether he is ascending or descending an incline.

Such slight variations are more easily observed on the aneroid than on the mercurial barometer, and therefore it is commonly stated that the aneroid is the more sensitive instrument. This, however, is a fallacious conclusion. It is not the superior sensitiveness of the movements of the instrument, but the greater facility of reading them, that gives this advantage to the aneroid, the index of which has a needle point traveling nearly in contact with the foot of the divisions; the readings are further aided by a needle point register attached to a movable rim, which may be brought point to point against the index, thus showing the slightest movement that human vision may detect. A magnifying lens may be easily used in such a case.

It should be understood that the aneroid barometer is not an independent instrument; it is merely a device for representing the movements of the mercurial barometer. It is regulated by comparison with the primary instrument, and this comparison should be renewed from time to time, as the elastic properties of the metal may and do vary.

An adjusting or regulating screw is attached to the back of the instrument, and is usually movable by a watch key.

Besides this, the magnified reading of course magnifies any primary error, and is largely dependent on the accuracy of the mechanism.

The Albo-Carbon Light.

We need hardly remind our readers that numerous unsuccessful attempts have been made at various times to enrich ordinary coal gas by the aid of volatile oils. Upon the present occasion we have to place before them particulars of a process having the same object in view, but which is so far dissimilar in that it deals with a solid substance instead of a liquid oil. The invention has been brought into its present practical shape by Mr. James Livesey, C.E., of No. 9 Victoria Chambers, Westminster, in conjunction with Mr. Kidd, with whom it originated. The process consists in the employment of a substance called albo-carbon, which is the solid residuum of creosote. This material is moulded into the form of candles, which in large lamps are placed in a metallic vessel or receiver near the gas burner. The albo-carbon is warmed by the heat of the burning gas, the heat being transmitted to the receiver by a metallic conductor. Upon the albo-carbon being raised to the necessary temperature it volatilizes, and as the coal gas passes over it to the burner its vapor becomes mingled with the gas, and greatly raises its illuminating power. Of course when first lighted the coal gas only is burned, but in a few minutes the albo-carbon communicates its enriching vapor to it. The only alteration necessary to the present gas fittings is the vaporizing chamber, which is of simple construction, although at present the details of the various arrangements necessary for the different kinds of lights have not yet been fully worked out. This invention is now being tried experimentally in the eastern section of the Westminster Aquarium, where we recently examined it, and found it to afford a marked improvement upon the ordinary system of gas illumination, although a smaller number of burners is being used. Tried alternately with ordinary coal gas, the higher illuminating power of the albo-carbon light was very remarkable. It appears that there are 200 burners fitted at the Aquarium with the new light, and these successfully take the place of 500 ordinary gas burners previously in use. The illuminating effect is stated to be doubled, with an additional advantage as regards economy. The reduction of cost arises from the smaller quantity of gas consumed with the albo-carbon process than without it, and the very small cost of the enriching material. According to our information, 1,000 cubic feet of ordinary gas as generally used will, by the albo-carbon appliance, give as much illumination as 3,000 cubic feet without it, and the cost of the material to produce this result is only 1s. 6d. Experiments have been made with this light by Mr. T. W. Keates, the consulting chemist to the Metropolitan Board of Works, who reports very favorably upon it, as does also Dr. Wallace, of Glasgow, who has obtained some very satisfactory results with it. It is claimed for the albo-carbon material that it is perfectly inexplorable, safe and portable, that it causes no obstruction and leaves no residuum, and that the receivers can be replenished almost indefinitely without any accumulation taking place, so perfect is the evaporation of the albo-carbon. On the whole the display at the Aquarium speaks greatly in favor of the new process of gas enrichment, which, other things being equal, bids fair to find its way into practice.—*Engineering.*

English and American Hardware.

Mr. Frederick Smith, Manager of the Union Land and Building Company (limited), recently read a paper on the above subject before the Manchester Scientific and Mechanical Society. Mr. H. Whaley, Superintendent of the Manchester Health Department, presided. The following is the text of the paper, as given in the *Ironmonger*. The lecturer said:

A spectator in any of our courts of justice will generally be struck with the amount of hard swearing which is given to the court, under the name of evidence. He will find one set of witnesses testifying, under oath, to one thing, and another set, also under oath, to the very opposite. Some prove too much, some too little, some are of a totally negative character, proving nothing, and some are of no character at all, and therefore are willing to prove anything. To some extent the same phenomena are to be observed in reference to the question of foreign competition. On the one hand the manufacturers hold up to our affrighted vision the picture of our mills stopped, our machine shops standing empty and idle, our hardware trade slipping through our fingers, our ships rotting in our own and in foreign ports, and our greatness as a producing nation for ever passed away. On the other hand, the journalists who take the labor side of the question, the trades-union leaders, and a large number of the workmen themselves, hold that we have little or nothing to fear from our foreign rivals; that the depression, like those atmospheric ones of which our American cousins are constantly warning us, will pass away, and leave us with better times to follow. I will, therefore, as far as possible, keep out of the region of speculation, give you a few facts, show you some examples, and leave you to draw your own in-

ferences. Some two or three years ago ordinary axle pulleys of English make were difficult to get; the price was scandalously high, and the quality as scandalously low. Out of a dozen probably four would not turn round without sticking, and the casting was—well, simply vile. I show you a sample rather above the average, and the retail price for this inferior article was 22s. per gross. All at once the Americans deluged the English market with the pulley which I now show to you, and it needs no explanation of mine to satisfy the mechanical minds present of the superiority of the transatlantic article; but when we also bear in mind that the price of the American was from 25 to 33 per cent less than the English pulley, you can understand how the builders exulted, and how the Volscians of the Birmingham district were fluttered. Then, and not till then, would the English maker condescend to believe that it was possible to improve upon the wretched things which he had foisted upon his customers, and he at once commenced to copy the American pulley. He has not yet succeeded in producing such a beautiful casting, but I venture to say that he has improved the quality more in the last eighteen months than in the previous eighteen years.

Now take the ordinary door furniture. For generations the English builder and householder has had to be content with the stereotyped, with all its aggravating propensities. First, the little screw (so small as to be scarcely perceptible to touch or to sight) shakes loose from its countersunk depression in the spindle, gets lost, and lets the knob go adrift; or next, the knob itself, formed of a bit of sheet brass, turns round on its shank and the door cannot be opened, or the shank, not having a sufficient bearing on the spindle, works loose, and the whole thing is out of repair. It is the same thing to-day as it was when it tormented my grandfather; for, of course, no improvement could be made until Uncle Sam sent us his cheap, strong, serviceable, and sensible "Mineral Knob."

The English maker says: "But look at the many devices which we have invented for door furniture." Granted, and some of them very good, but none of them so good as this—for the money. Plenty of them well adapted for extraordinary use, but none of them cheap enough and strong enough to be placed in competition with this in fitting up the dwelling of the ordinary Englishman. The spindle and furniture of a lock is the portion which is liable to and receives the most rough usage.

I have here an ordinary cheap set of china furniture of English make, which I dare not drop lest I should break it, but as you see, I dare throw its Yankee competitor the whole length of this room. The retail price of this English set is ninepence—the price of the American is less than sixpence. The English spindle is fitted with the usual little screw, the knob is loose, the roses are china, and liable to break with the least strain or blow. The American set, as you see, has a long shank; the form of the knob is a very oblate spheroid, giving a good grip and free play for the fingers between the knob and the door. The rose is japanned iron, and has small studs or teeth projecting on its inner side effectually preventing it from turning round with the spindle; the screw is strong, and is tapped through the spindle itself, insuring both security and perfect steadiness. Several small washers are supplied with each spindle, enabling the slack to be taken up perfectly, and at the same time preventing the spindle from sticking with any ordinary amount of friction.

I will now show you a cheap American rim lock. First, you will notice that both sides are alike. Next, that by pulling the latch forward it can be turned half round, and is thereby converted from a right hand to a left hand, or *vice versa*, in an instant. This is an important point to a builder, but our lockmakers do not seem to know it. Several attempts have been made to introduce locks of this kind, but the fancy prices put upon every article which departs, in ever so slight a measure, from the antediluvian patterns mostly used, practically prohibits their adoption. The carcass of the lock is of cast iron; the casting, like all the small American castings, is simply perfect; bosses are cast round the follower and keyholes; the box staple is one piece of metal, neat and strong.

But there is another point, and, to my mind, the most important one. Whatever opinions may be held as to the relative quality of this lock, whether it is better or worse than an English one, it is at least an honest article. It makes no pretensions to be any better than it is. It does not entrap the unwary purchaser by pretending to be a first-class article, when at the same time it may be a swindle.

I will now show you an ordinary 6 inch rim-lock of English manufacture. At a short distance it looks like a superior article; the follower and keyhole appear as if they were bushed with brass. But let us take it to pieces, and see what we can find. The follower is a rough casting, not turned at the bearings, and is in no sense a fit. The screw holes are not countersunk, but merely punched in; the key is of the roughest and worst fitting description; the inside is as rough and cheap as possible; the key is cut so as to deceive the purchaser into the belief that there are twice as many wards in the lock as is really the case, and the bushes prove to be thin plates of brass riveted on, and not bushes at all. In short, the whole article is a vile fraud, and the maker was a swindler. This is strong language, but I think you will agree with me when I maintain that it is not stronger than the circumstances warrant.

But there are still its defects of bad design and useless workmanship. The lock is of the usual form given to the

English rim-lock, that is, it has a flange which requires to be let into the edge of the door. I have fixed hundreds of them, and have never yet been able to see a use for this flange. It is one great obstacle to the general introduction of a reversible lock; it adds to the labor of fixing without adding to the security of the door, for if the door is to be forced from the outside, the box staples give way first; if from the inside, the unscrewing of the box staple is all that is necessary to give egress; if the door requires easing, it effectually prevents it being done—in fact, it is a nuisance, and nothing but a nuisance. But our lockmakers do not appear to give these things a thought; their doctrine seems to be, "As it was in the beginning, is now, and ever shall be."

Again, notice that the edges of the iron which lie against the door and the sham bushes are ground bright. Here is labor wasted, for as soon as the lock is fixed these polished portions are hidden for ever. Next, take the box staple. As is usual, it is fearfully and wonderfully made up of sheet iron, square iron, and brass; the outcome of which is that the showy brass striking piece comes unriveted, the door comes unfastened, and the tenant's temper comes unhinged. Why, in the name of common sense, could they not substitute a neat malleable casting? In our own houses I have long since discarded the ordinary box staple for draw-back locks, and find it cheaper to buy a cast iron staple, and throw away the one supplied by the English lockmaker.

Bear in mind that I have shown neither of these locks as samples of high-class goods, but as samples of the furniture fixed in the houses of the working and middle classes of this country; and when I tell you that the American lock, fitted with the mineral furniture, is at least 25 per cent cheaper than the English abortion I have shown to you, you will begin to realize what our English markets have to fear from the Americans.

Here is a common, cheap English mortise lock, and you will naturally ask why the outside of this lock is ground bright, when it is buried in the door and never seen except it has to be taken out for repairs. I have asked the same question, and for 20 years have paused for a reply. This lock is not reversible, the follower is not bushed, and the inside is rough and cheap. Contrast it with this neat American lock, and notice again the bosses to receive the wear; notice also that the bolts are brass; the latch-bolt is, of course, reversible—I never saw an American lock which was not. The body of the lock is cast iron; and, seeing that there are no strains upon a mortise lock, it is quite as good as if it was of wrought iron. There is no unnecessary grinding, but the iron is japanned, and the japan is as much superior to the English compound as is the lacquer ware of the Japanese to that which is executed in Birmingham and palmed upon the ignorant buyer as Japanese work. In fact, as you can see for yourselves, the English japan looks almost like gas tar beside the American. This American lock is a two-lever, and there is no sham about the key, which is made of some kind of white metal and is small and neat. This lock is only 2½ per cent higher in price than the English.

Before leaving these locks, let me say a word or two upon the relative wear upon their different portions, and their relative safety. The English maker appears to ignore the fact that nineteen-twentieths of the wear of a lock is upon the latch, spindle, and follower; the amount of actual wear upon the rest of the lock is comparatively slight. Let any of you consider the number of times you open and close a door, compared with the times you lock it. Our drawbacks and large rim locks are used about once a day; the great bulk of our mortise locks are not used, except as latches, once a week. One argument used by our manufacturers against the American lock is that, being made by machinery, there is necessarily a great duplication of parts, and a consequent lowering of the standard of security; while their own locks, being made by hand, are not alike, and therefore cannot be so easily opened.

Let any of you put this argument to proof, by trying how many front doors you can open with one key in a row of workmen's dwellings such as are found in Manchester, ranging up to £25 rentals, and the result will astonish you. If our own manufacturers made their locks sufficiently well to give this security, there would be some force in what they say; but so far as security is concerned, they might as well make their locks by machinery as make them in the way they do.

I now show you two thumb latches, one of American and one of English make. Notice the general finish of the American latch; the shape, the mode of construction, and everything about it proves that brains were used when it was designed and made. The English "Norfolk latch," on the other hand, is ill designed, uncomfortable in hand, clumsily finished, the japan hangs about it in lumps, the latch is clumsy, the catch is clumsy, and the keeper, a rough piece of hoop iron, seems as if designed to "keep" the latch from doing its duty. In this case the American latch is 25 per cent cheaper than the English one; and the English latch is of the same pattern as the one that was in use when I was a boy, only that it is a greatly inferior article.

I will now introduce you to the well known nuisance which we have been accustomed to use for fastening our cupboard doors—the cupboard turn—and without further comment, ask you to compare it with this neat and simple latch of American make, costing about 5 per cent more, twice as efficacious, and five times as durable. In this case no improvement has been made in the English fastener. It is just as it was when I went to the trade, about 28 years ago, and although many attempts have been made to im-

prove it they have added so much to its cost as to prevent the improved articles from coming into general use.

The difference between the English and American inventor and designer seems to consist in this—that while an Englishman devotes all his energies to the improvement of an existing shape, the American throws the old article under his bench and commences *de novo*.

I think I have made out a case against the English hardware manufacturer, but when I have pointed these matters out to merchants and ironmongers, I have been met with various reasons for this manifest inferiority. I do not know how far these excuses may be valid, but one man says that the reason, as regards locks, is somewhat as follows: The locksmiths of the district wherein they are made in many cases work at their own homes; one man making one part of a lock, while other men make other parts. This goes on generation after generation, and the men become mere machines, not knowing how the entire lock is constructed, and not caring to know. Another attributes it to the influence of the trades-unions, and says that if a manufacturer wants a different kind of lock, the price for the work is immediately put higher, even though the actual labor may not be increased. A third says it is due to the drunkenness of the hands, and their consequent poverty and physical and social demoralization, which prevents them from rising to such an intellectual level as will enable them to see the evils of their system, and adopt the right means to remove them. A fourth boldly says, "We make these goods because our customers want them." How far the reasons assigned by the first three are correct I am unable to say, but for the fourth, the extent to which the builders of England have patronized the Americans is a complete answer.

This defense, "Our customers want them," is as old as the hills, and has been used to cover every kind of deception and inferior article ever manufactured. Our Lancashire manufacturers use it when they are charged with sending china clay and mildew (and call it calico) for the mild Hindoo and the Heathen Chinee to dress themselves in. Our butter merchants use it when they make up grease and call it butter; and our hardware merchants use it when they send us sham locks, and call them brass bushed, etc.

It is the duty of the manufacturer to invent for his customers, and it is preposterous to say that the builder would prefer that embodiment of fraud—the English rim-lock, which I showed to you—to the American lock, which, at any rate, was an honest article, especially when the latter had the great advantage of being considerably cheaper. I am afraid that the swindling and greed of our merchants is having the effect of thrusting us out of the markets of the world, including our home markets; and when it is too late, these men who are making the name of English goods a byword and a reproach, even among the Hindoos, the Chinese, and the untutored savages of the South Sea Islands, will find that "honesty is the best policy."

We have been accustomed to hear a deal of buncombe talked about the honesty of the Englishman, and the want of honesty of the Yankee; about the enterprise of our manufacturers and the skill of our workmen; but if what I have shown to you is to be taken as a specimen, it is time we set our house in order. Since commencing the paper I have read the discussion between Messrs. Chubb and Hill, and am at a loss to know why Messrs. Chubb entered into the arena. If all the English makers tried to reach Chubb's standard we should keep our markets, at least so far as high quality is concerned; and to see Messrs. Chubb acting as champions of the English lockmakers is something like seeing Messrs. Horrocks taking up the cudgels for those people who manufacture china clay and call it calico, the proportion of fiber in the material being just a little greater than that found in hair mortar.

In conclusion, I wish it to be understood that I bring these facts before you in no exultant spirit. I am an Englishman, and the future welfare of myself and my children depends very much upon the future of English manufactures; but we cannot be blind to the fact that the apathy and conservatism of our manufacturers, the greed of our merchants, and the ignorance and drunkenness of our workmen, are weighing us so heavily in the race for trade that a member of our own family, whose leading business should be to produce food for us, is outstripping us with the greatest ease. Our boasted supremacy as a manufacturing people is leaving us, and leaving us under such humiliating circumstances—and if the men of Birmingham and the district are content to dwell in their present "fools' paradise," it is the duty of every lover of his country to speak as plainly as possible to them.

Of course I am prepared to be told that as I am not a lockmaker my opinion is worthless; but I have been about 28 years as man and boy, employer and workman, in the building trade, and if I have not got to know something about builders' hardware during that period, I have made but a poor use of my time. I do not know if I have added to your stock of knowledge, but deeming the subject an important one, I have done the best I could in the time at my disposal.

In the discussion which followed the opinion of the members present was unanimously in favor of the American articles shown to them.

A HIGH Indian official reports that the people of Cashmere are dying of famine like flies, and at the present rate of mortality the province will be nearly depopulated by the end of the year.

TO INVENTORS.

An experience of more than thirty years, and the preparation of not less than one hundred thousand applications for patents at home and abroad, enable us to understand the laws and practice on both continents, and to possess unequalled facilities for procuring patents everywhere. In addition to our facilities for preparing drawings and specifications quickly, the applicant can rest assured that his case will be filed in the Patent Office without delay. Every application, in which the fees have been paid, is sent complete—including the model—to the Patent Office the same day the papers are signed at our office, or received by mail, so there is no delay in filing the case, a complaint we often hear from our sources. Another advantage to the inventor in securing his patent through the Scientific American Patent Agency, it insures a special notice of the invention in the SCIENTIFIC AMERICAN, which publication often opens negotiations for the sale of the patent or manufacture of the article. A synopsis of the patent laws in foreign countries may be found on another page, and persons contemplating the securing of patents abroad are invited to write to this office for prices, which have been reduced in accordance with the times, and our perfected facilities for conducting the business. Address MUNN & CO., office SCIENTIFIC AMERICAN.

Business and Personal.

The Charge for Insertion under this head is One Dollar a line for each insertion; about eight words to a line. Advertisements must be received at publication office as early as Thursday morning to appear in next issue.

Valves and Hydrants, warranted to give perfect satisfaction. Chapman Valve Manuf. Co., Boston, Mass.
Brown & Sharpe, Prov., R. I. Best Gear Teeth Cutters and Index Plates at low prices. Send for catalogue.
Wanted—Galvanic Battery, Induction Coil, Electro-Magnet. Address, with description and price, Box 1700, Boston, Mass.
New Steam Governor.—Entire right for \$3,000. For circulars address E. Towns, Cisne, Ill.
Gutta Percha, pure and sheeted, for sale in quantities to suit. Anderson & Reynolds, Salem, Mass.
The new fragrant Vanity Fair Cigarettes. New combinations of rare Old Perique and Virginia.
Wanted—Second-hand Corliss Engine, 100 to 125 H. P. Address P. O. Box 1208, New Haven, Conn.
17 and 20 in. Gibed Rest Screw Lathes. Geo. S. Lincoln, Hartford, Conn.
"Downer's Anti-Incrustation Liquid" for Removal and Prevention of Scales in Steam Boilers, is spoken of in highest terms by those who have given it a thorough trial. Circulars and price lists furnished on application. A. H. Downer, 17 Peck Slip, New York.

Mr. W. B. Adams, one of the most extensive contractors and decorators in this city, says he has used nearly fifty thousand gallons of H. W. Johns' Asbestos Liquid Paints, and after an experience of twenty years with white lead and other paints, he considers them not only superior in richness of color and durability, but owing to their wonderful covering properties, they are fully 20 per cent more economical than any others.
New Pamphlet of "Burnham's Standard Turbine Wheel" sent free by N. F. Burnham, York, Pa.
Gaume's Electric Engine. 171 Pearl St., B'klyn., N. Y.
Engines, 1/2 to 5 H. P. G. F. Shedd, Waltham, Mass.
Clipper Injector. J. D. Lynde, Philadelphia, Pa.
Diamond Drills, J. Dickinson, 64 Nassau St., N. Y.
Eagle Anvils, 9 cents per pound. Fully warranted.
Case Hardening Preparation. Box 73, Willimantic, Ct.
Vertical Burr Mill. C. K. Bullock, Phila., Pa.
Sheet Metal Presses, Ferracute Co., Bridgeton, N. J.
Mundy's Pat. Friction Hoist. Eng., of any power, double and single. Said by all to be the best. J. S. Mundy, Newark, N. J.

Auction Sale.—The Machinery and Property of the well known Hardie's Machine Works, 62 and 64 Church St., Albany, N. Y., will be sold March 26, at noon. No postponement.
To Manufacturers or Capitalists.—A rare chance to control a valuable agricultural patented implement. Address S. A. Fisher, Maplewood, Mass.
Reflecting Telescope, 6 1/2 inches aperture, well mounted, price only \$70. J. Ramsden, Philadelphia, Pa.
See Hogins' Laundry Table, illustrated on page 194. State, Canada, and entire right for sale.
Emery.—Best Turkey Emery in bbls., kegs, and cases in quantities to suit. Greene, Tweed & Co., 18 Park Place, N. Y.

The SCIENTIFIC AMERICAN Export Edition is published monthly, about the 15th of each month. Every number comprises most of the plates of the four preceding weekly numbers of the SCIENTIFIC AMERICAN, with other appropriate contents, business announcements, etc. It forms a large and splendid periodical of nearly one hundred quarto pages, each number illustrated with about one hundred engravings. It is a complete record of American progress in the arts.

Gold, Silver, and Nickel Plater wants situation. Address Plater, Oakville, Conn.
Amateur Photo. Apparatus, including instructions; outfits complete. E. Sackmann & Co., 278 Pearl St., N. Y.
Outfits for Nickel and Silver Plating, \$5 to \$200. Union Silver Plating Company, Princeton, Ill.
Send for Circulars of Indestructible Boot and Shoe Soles to H. C. Goodrich, 40 Hoyne Ave., Chicago, Ill.
For Sale.—Brown & Sharp Universal Milling Machine; Bement Profiling Machine; first-class 2d hand Machine Tools. E. P. Bullard, 14 Dey St., New York.
For Sale.—7 foot bed Putnam Planer, \$350. A. A. Pool & Co., Newark, N. J.
Bevins & Co.'s Hydraulic Elevator. Great power, simplicity, safety, economy, durability. 94 Liberty St., N. Y.
A Cupola works best with forced blast from a Baker Blower. Wilbraham Bros., 2318 Frankford Ave., Phila.
Shaw's Noise Quieting Nozzles and Mercury Pressure Gauges. T. Shaw, 915 Ridge Ave., Philadelphia, Pa.
For Solid Wrought Iron Beams, etc., see advertisement. Address Union Iron Mills, Pittsburgh, Pa., for lithograph, etc.
H. Prentiss & Company, 14 Dey St., N. Y., Manufs Taps, Dies, Screw Plates, Reamers, etc. Send for list.
Presses, Dies, and Tools for working Sheet Metal, etc. Fruit & other can tools. Bliss & Williams, B'klyn., N. Y.

Nickel Plating.—A white deposit guaranteed by using our material. Condit, Hanson & Van Winkle, Newark, N. J.
Hydraulic Elevators for private houses, hotels, and public buildings. Burdon Iron Works, Brooklyn, N. Y.
The Lathes, Planers, Drills, and other Tools, new and second-hand, of the Wood & Light Machine Company, Worcester, are to be sold out very low by the George Place Machinery Agency, 121 Chambers St., New York.
Hydraulic Presses and Jacks, new and second hand. Lathes and Machinery for Polishing and Buffing Metals E. Lyon & Co., 470 Grand St., N. Y.
Solid Emery Vulcanite Wheels.—The Solid Original Emery Wheel—other kinds imitations and inferior. Caution.—Our name is stamped in full on all our best Standard Belting, Packing, and Hose. Buy that only. The best is the cheapest. New York Belting and Packing Company, 37 and 38 Park Row, N. Y.
Pulverizing Mills for all hard substances and grinding purposes. Walker Bros. & Co., 23d & Wood St., Phila., Pa.
Portland Cement—Roman & Keene's, for walks, cisterns, foundations, stables, cellars, bridges, reservoirs, breweries, etc. Remit 25 cents postage stamps for Practical Treatise on Cements. S. L. Merchant & Co., 53 Broadway, New York.

Needle Pointed Iron, Brass, and Steel Wire for all purposes. W. Crabb, Newark, N. J.
Manufacturers of Improved Goods who desire to build up a lucrative foreign trade, will do well to insert a well displayed advertisement in the SCIENTIFIC AMERICAN Export Edition. This paper has a very large foreign circulation.
Band Saws, \$100; Scroll Saws, \$75; Planers, \$150; Universal Wood Workers and Hand Planers, \$150, and upwards. Bentel, Margedant & Co., Hamilton, Ohio.
The best Friction Clutch Pulley and Friction Hoisting Machinery in the world, to be seen with power applied, 95 and 97 Liberty St., New York. D. Frisbie & Co., New Haven, Conn.

C. M. Flint, Fitchburg, Mass., Mfr. of Saw Mills and Dogs, Shingle and Clapboard Machines. Circulars.
Blake's Belt Studs; strongest, cheapest, and best fastening for Leather or Rubber Belts. Greene, Tweed & Co., New York.
No gum! No grit! No acid! Anti-Corrosive Cylinder Oil is the best in the world, and the first and only oil that perfectly lubricates a railroad locomotive cylinder, doing it with half the quantity required of best lard or tallow, giving increased power and less wear to machinery, with entire freedom from gum, stain, or corrosion of any sort, and it is equally superior for all steam cylinders or heavy work where body or cooling qualities are indispensable. A fair trial insures its continued use. Address E. H. Kellogg, sole manufacturer, 17 Cedar St., New York.
The unprecedented demand for Kinney Bros.' New Cigarette, Sweet Caporal, is a good recommendation as to their merit.
Wheels and Pinions, heavy and light, remarkably strong and durable. Especially suited for sugar mills and similar work. Pittsburgh Steel Casting Company, Pittsburgh, Pa.

Deoxidized Bronze. Patent for machine and engine journals. Philadelphia Smelting Co., Phila., Pa.
For Sale.—4 H. P. Vertical Engine and Boiler (New York Safety Steam Power Co.'s make), as good, and in some respects better, than new. Address H. M. Quackenbush, Herkimer, N. Y.
Wood-working Machinery, Waymouth Lathes. Specialty, Wardwell Patent Saw Bench; it has no equal. Improved Patent Planers; Elevators; Dowel Machines. Rollstone Machine Company, Fitchburg, Mass.
Galland & Co.'s improved Hydraulic Elevators, Office 206 Broadway, N. Y., (Evening Post Building, room 22.)
The only economical and practical Gas Engine in the market is the new "Otto" Silent, built by Schleicher, Schumm & Co., Philadelphia, Pa. Send for circular.
Dead Pulleys that stop the running of loose pulleys and their belts, controlled from any point. Send for catalogue. Taper Sleeve Pulley Works, Erie, Pa.

Vick's Illustrated Monthly Magazine is one of the most beautiful magazines in the world. Each number contains a chromo of some group of flowers, and many fine engravings. Published monthly at \$1.25 per year. Address James Vick, Rochester, N. Y.

Notes & Queries

HINTS TO CORRESPONDENTS.
No attention will be paid to communications unless accompanied with the full name and address of the writer.
Names and addresses of correspondents will not be given to inquirers.
We renew our request that correspondents, in referring to former answers or articles, will be kind enough to name the date of the paper and the page, or the number of the question.
Correspondents whose inquiries do not appear after a reasonable time should repeat them.
Persons desiring special information which is purely of a personal character, and not of general interest, should remit from \$1 to \$5, according to the subject, as we cannot be expected to spend time and labor to obtain such information without remuneration.
(1) S. Q.—The speed of a circular saw at the periphery should be from 6,000 to 7,000 feet per minute. The number of revolutions per minute will of course vary with the diameter of the saw.
(2) T. J. F. asks (1) for the best way to fasten emery on a wooden wheel, to be used in place of a solid emery wheel. A. Cover the wheel with leather devoid of grease, and coat the leather surface, a portion at a time, with good glue; immediately roll the glued surface in emery spread out on a board. 2. How can I fasten small pieces of looking glass on iron? A. Use equal parts of pitch and gutta percha melted together.
(3) W. C. asks: 1. What is the power of the simple electric light described in SUPPLEMENT No. 149? A. When supplied with a strong current it is equal to 5 or 6 5-foot gas burners. It is designed for temporary use only. 2. What is the cost of manufacturing the dynamo-electric machine in SUPPLEMENT No. 161?

A. The one shown in the article referred to cost about \$35.
(4) L. D. asks: 1. Which is the better conductor, silver or copper? A. Silver. 2. And the comparative resistance offered to the electric current by water and the above? A. Taking pure silver as 100,000,000, the conductivity of distilled water would be 0.01.
(5) H. J. F. writes: In SUPPLEMENT 162 a simple electric light is described. I wish to light a room 30x20x10 feet. 1. How large is the bell glass? A. 3 1/2 inches. 2. Can I use battery carbon? A. Use a carbon pencil made for electric lamps. 3. How can I make tray water tight after putting wire through? A. With gutta percha. 4. I have one large cell Bunsen and one Smee. How many more and of what kind shall I get? A. One of the batteries described in SUPPLEMENTS 157, 158, 159, will do, probably 8 or 10 Bunsen elements would be the best.

(6) W. B. F. writes: I tried to make an electric pen, like the one described in your SCIENTIFIC AMERICAN, of February 22d, 1879, using a Smee's battery, a circuit breaker, and an induction coil, but it did not work. Is there anything wrong, or is a condenser different from an induction coil? A. A condenser consists of a number of sheets of tin foil separated from each other by larger sheets of paper. One half of the tin foil sheets are connected with one terminal of the primary coil, the other half with the other terminal; the tin foil sheets connected with one terminal alternate with those of the other terminal. The condenser is essential to the working of the coil. For complete directions for making induction coils, see SCIENTIFIC AMERICAN SUPPLEMENT No. 160.

(7) J. De F. asks: 1. Knowing the resistance of a wire of given conductivity, length, and diameter, will the resistance of any other wire be in proportion inversely? A. Yes. 2. Is there heat enough developed in the secondary coil of an induction coil to prevent the use of paraffine as an insulating material? A. With proper battery power, no. 3. How high in the list of non-conductors does paraffine stand? A. It is one of the best. 4. Will a cotton insulator soaked in paraffine answer as well as silk? A. No, because it renders the covering of the wire too thick. 5. Can you recommend any insulating material for making induction coils which will dry rapidly? A. Alcoholic shellac varnish. Rosin to which a little beeswax has been added is an excellent insulator; it must be applied in a melted state. 6. What is the composition of the black material covering the Leclanche porous cell? A. Gutta percha. 7. Is the magneto-electric machine described in the SCIENTIFIC AMERICAN SUPPLEMENT patented? A. To which do you refer? Most, if not all of them are patented.

(8) B. V. F. writes: With reference to item 8, on page 139, of SCIENTIFIC AMERICAN, March 1, 1879, I think there is some mistake about the coal you think required to heat 1,000 cubic feet space. I burn some 8 tons coal to heat, in the whole year, such part of my house as must exceed 25x20x18=9,000 cubic feet. We keep up a moderate heat at night. Ventilate more than most families do; take part only of the cool air, and only in part of the coldest weather, from the cellar, which at such times is opened into the main entries, House wood, back plastered, and stands alone. If 100 lbs. coal would heat 1,000 feet one day, I ought to burn 900 lbs. a day, or nearly 14 tons in December and 14 more in January. A. We are glad to receive these data, which correspond quite closely with some obtained by recent accurate experiments. The estimate given in the SCIENTIFIC AMERICAN also agrees well with experiments on the use of hot air heaters for very small buildings or rooms. Of course, the larger the space to be heated, the more economically it can generally be done.

(9) W. M. S. asks: Will the coil described in SUPPLEMENT No. 160 do for the electric pen described in a recent number of the SCIENTIFIC AMERICAN? If not how must it be changed? A. It is too large; make it one half the size given.

(10) B. G.—In reply to your inquiry as to Mr. Stroh's telephone experiment, we give the following, which we clip from the English Mechanic: A singular experimental effect, of special interest just now from its possible bearing on the theory of the source of sound in the Bell telephone, has just been observed by Mr. Stroh, the well known mechanician. If a telephone, T, with the circuit of its coil left open, be

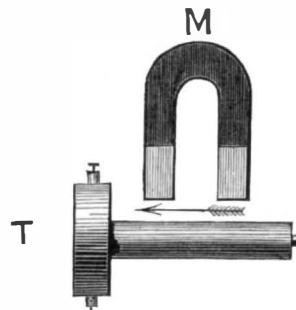

held to the ear, and a powerful magnet, M, be moved gently up and down along the length of the magnet, as shown by the arrow, and at a distance of an inch or two from it, a faint breathing sound will be heard, the recurring pulses of sound keeping time with the up and down motion of the magnet. The sound may be aptly compared to the steady breathing of a child, and there is a striking resemblance between it and the microphonic sounds of gases diffusing through a porous septum as heard by Mr. Chandler Roberts. We understand that Professor Hughes is investigating the cause of this curious sound by help of the microphone.
(11) "Enterprise" asks: What part of its volume will iron expand in passing from a temperature of 60° to melting temperature? A. The cubical expansion of iron for each degree (C) between 0° and 100° is 0.00003546 of its volume, its volume being 1. This ratio however, increases somewhat at higher temperatures, since the mean coefficient of expansion for each degree

between 0°C. and 300° C. is 0.00004405. The question you ask has probably never been settled. You may form an approximation by the use of the above ratios, knowing the melting point of the iron.

(12) P. L. O. asks for a good chemistry for a beginner to study without a teacher. A. Fownes' "Chemistry;" Gorup-Besanez, "Inorganic, Organic and Physiological Chemistry."

(13) L. E. M. asks: What is the best method of keeping fine guns from rusting, and what oil should be used? A. For the outside, clear gum copal 1 part, oil of rosemary 1 part, absolute alcohol 3 parts. Clean and heat the metal and apply a flowing coat of the liquid by means of a camel's hair brush. Do not handle until the coat becomes dry and hard. For the inside of the barrel a trace of refined sperm oil is as good as anything, but an excess should be avoided.

(14) A. H. B. asks how much weight, falling 10 feet, will be required to produce one horse power for five hours? A. One horse power for 5 hours=33,000 x 300=9,900,000 foot pounds—so that the weight required is 9,900,000÷10=990,000 lbs.

(15) A. D. R. asks: 1. In renewing a Leclanche battery, do the zincs have to be amalgamated? A. They are usually amalgamated. 2. Will two cells large size Leclanche battery give any light, using the simple lamp described in SUPPLEMENT No. 162? A. No.

(16) H. L. J. writes: In a recent issue of the SCIENTIFIC AMERICAN you state that the floating of solid iron on melted iron is on the same principle as the floating of ice in water. I do not quite understand how it can be. Please explain. A. Solid iron, at an elevated temperature, floats upon molten iron for the same reason that ice floats upon molten ice—water—because it is specifically lighter. You will find the subject discussed at length in Tyndall's "Heat as a Mode of Motion."

(17) J. W. will find full directions for canning corn, etc., on p. 394 (4), vol. 39, SCIENTIFIC AMERICAN.

(18) "Amateur" writes: I wish to make some small bells that have a clear ring. What metal or metals can I use that I can melt easily? A. Use an alloy of tin and antimony. See SCIENTIFIC AMERICAN SUPPLEMENT No. 17.

(19) H.—A nutritious mixed diet is unquestionably the best, care being taken to avoid an excess of meat.

(20) W. F. writes: I have made an engine, and would like to find out what size of boiler it will require. The cylinder has 2 1/4 inch bore and 3 inches stroke. A. It depends upon pressure and speed to be maintained; probably a vertical tubular boiler, 15 inches diameter, and 32 to 36 inches high, would suit you.

(21) R. G. (Salt Lake).—Please send full name.

(22) J. M. G. asks: If two persons each pull one hundred pounds on opposite ends of a rope, what will be the strain on the rope? A. The strain on the rope will be 100 lbs.

(23) W. M. M. asks: In laying off a mill stone in furrows, what draught is given? What amount of the space of a stone is given to furrows and what to grinding surface? A. There is considerable difference in the practice of various millers, and we would be glad to receive communications from those experienced in the art of dressing millstones.

MINERALS, ETC.—Specimens have been received from the following correspondents, and examined, with the results stated:

S. (New Orleans).—The powder consists of a mixture of zinc oxide and finely powdered resin. A quantitative analysis would be necessary to determine the proportions.

Any numbers of the SCIENTIFIC AMERICAN SUPPLEMENT referred to in these columns may be had at this office. Price 10 cents each.

COMMUNICATIONS RECEIVED.

Life Preserving Stone. By J. D. W.
On Ventilation. By D. W.
What is Mental Action? By N. K.
Panama Railroad or Canal. By G. R. P.
A Problem. By K.
On the Gary Motor. By G. F. M.
Magnetic Motor. By G. W. W., W. A. A., G. H. F.
House Warning. By H. B. F.
The Injector. By M. A. B.
Columbus' Problem; Cure for Diphtheria; The Mulein Cure for Consumption. By R. W. L.
A Visit to Tra. By L. R.
On Vacuum in Pumps and the Atwood Machine. By P. J. D.
On the Patent Bill. By R.

[OFFICIAL.]

INDEX OF INVENTIONS

FOR WHICH Letters Patent of the United States were Granted in the Week Ending February 18, 1879, AND EACH BEARING THAT DATE. [Those marked (r) are reissued patents.]

Air heater, W. Pickhardt.....	212,499
Anchor, A. F. White.....	212,340
Animal trap, S. J. Bennett.....	212,430
Axle box, vehicle, P. K. Hughes.....	212,382
Axle, carriage, C. H. Kendall.....	212,387
Axle for wagons, trussed, J. Herby.....	212,378
Axle, vehicle, C. H. Kendall.....	212,386
Barrel cover, C. Brinton.....	212,350
Bed bottom, J. Flinn.....	212,451

Practical Draughtsman's Book of INDUSTRIAL DESIGN AND MACHINISTS' & ENGINEERS' Drawing Companion.

Forming a Complete Course of Mechanical, Engineering, and Architectural Drawing. From the French of M. Armengaud the elder, Professor of Design in Conservatoire of Arts and Industry, Paris, and MM. Armengaud the younger, and Amoroux, Civil Engineers. Rewritten and arranged with additional matter and plates, selections from and examples of the most useful and generally employed mechanism of the day. By William Johnson, Assoc. Inst. C. E. Illustrated by fifty folio steel plates, and fifty wood cuts. A new edition, 4to. \$10

Among the contents are: Linear Drawing, Definitions, and Problems. Sweeps, Sections, and Mouldings, Elementary Gothic Forms, and Rosettes. Ovals, Ellipses, Parabolas, and Volutes. Rules and Principal Data. Study of Projections, Elementary Principles, of Prisms and other Solids. Rules and Practical Data. On coloring Sections, with applications. Conventional Colors, Composition or Mixture of Colors. Continuation of the Study of Projection—Use of Sections—details of machinery. Simple applications—spindles, shafts, couplings, wooden patterns. Method of constructing a wooden model or pattern of a coupling. Elementary applications. Rules and Practical Data. THE INTERSECTION AND DEVELOPMENT OF SURFACES, WITH APPLICATIONS.—The Intersection of Cylinders and Cones. The Delineation and Development of Helices, Screws, and Serpentine. Application of the helix—the construction of a staircase. The Intersection of Surfaces—applications to stop cocks. Rules and Practical Data. THE STUDY AND CONSTRUCTION OF TOOTHED GEAR.—Involute, cycloid, and epicycloid. Involute, Cycloid, External, cycloid, described by a circle rolling about a fixed circle inside of it. Internal epicycloid. Delineation of a rack and pinion in gear. Gearing of a worm with a worm wheel. Cylindrical or Spur Gearing. Practical delineation of a couple of Spur wheels. The Delineation and Construction of Wooden Patterns for Toothed Wheels. Rules and Practical Data. CONTINUATION OF THE STUDY OF TOOTHED GEAR.—Design for a pair of bevel wheels in gear. Construction of wooden patterns for a pair of bevel wheels. Involute and Helical Teeth. Contrivances for obtaining differential Movements. Rules and Practical Data. ELEMENTARY PRINCIPLES OF SHADOWS.—Shadows of Prisms, Pyramids, and Cones. Principles of Shading. Continuation of the Study of Shadows. Tuscan Order. Rules and practical data. APPLICATION OF SHADOWS TO TOOTHED GEAR.—Application of Shadows to Screws. Application of Shadow to a Boiler and its Furnace. Shading in Black—Shading in Color. THE CUTTING AND SHAPING OF MASONRY.—Rules and Practical Data. Remarks on Machine Tools. THE STUDY OF MACHINERY AND SKETCHING.—Various applications and combinations: The Sketching of Machinery. Drilling Machines; Motive Machines; Water wheels. Construction and Setting up of water wheels. Delineation of water wheels. Design of water wheel. Sketch of a water wheel. Overshot water wheels. Water Pumps; Steam Motors; High-pressure expansive steam engine. Details of Construction; Movements of the Distribution and Expansion Valves; Rules and Practical Data. OBLIQUE PROJECTIONS. PARALLEL PERSPECTIVE. TRUE PERSPECTIVE.—Elementary principles. Applications—four mill driven by belts. Description of the mill. Representation of the mill in perspective. EXAMPLES OF FINISHED DRAWINGS OF MACHINERY. The above, or any of our books, sent by mail, free of postage, at the publication price. Our new and enlarged CATALOGUE OF PRACTICAL AND SCIENTIFIC BOOKS—96 pages, 8vo.—sent free to any one who will furnish his address. HENRY CAREY BAIRD & Co., INDUSTRIAL PUBLISHERS AND BOOKSELLERS, 810 WALNUT STREET, Philadelphia.

STEAM PUMPS. HENRY R. WORTHINGTON, 239 Broadway, N. Y. 83 Water St., Boston. THE WORTHINGTON DUPLEX PUMPING ENGINES FOR WATER WORKS—Compounding, Condensing or Non-Condensing. Used in over 100 Water-Works Stations. STEAM PUMPS—Duplex and Single Cylinder.

Price list issued Jan. 1, 1879, with a reduction exceeding 30 per cent. WATER METERS. OIL METERS.

EGGLESTON'S ELASTIC TRUSS. Has a Pad differing from all others, is cup-shaped, with Self-Adjusting Ball in center, adapts itself to all positions of the body, while the BALL in the cup PRESSES BACK the INTESTINES JUST AS A PERSON WOULD WITH THE FINGER. With high pressure cord. It is easy, durable and cheap. Sent by mail. Circulars free. Eggleston Truss Co., Chicago, Ill.

THE HANCOCK INSPIRATOR

TESTIMONIALS. OFFICE OF THE HANCOCK INSP. CO., LONDON, ENG., Feb. 11, 1879. I have just received an order from the English Government for 22 Number 15 Inspirators—making 24 machines in all for the Government this month. B. H. WARREN, Agent. OFFICE OF H. S. MANNING & Co., 111 Liberty St., New York, Feb. 26, 1879. GENTLEMEN: We have authority from Mr. Martin, Chief Engineer Union Ferry Co., Brooklyn, to state that they have 17 Inspirators at work on 17 of their boats, feeding their main boilers, and all giving satisfaction, and to refer any one to him. Yours truly, H. S. MANNING & Co., Agents.

Illustrated and Descriptive Circulars sent on application to Hancock Inspirator Co., 52 CENTRAL WHARF, BOSTON.

MOSELEY IRON BRIDGE AND ROOF CO. CORRUGATED IRON. Buildings, Roofs, Shutters, Doors, Iron Sashes, Skylights, etc. 5 Dey Street, New York.

BLAKE'S STONE AND ORE BREAKER AND CRUSHER. For breaking hard and brittle substances to any size. Endorsed by the leading Mining, Manufacturing, and Railroad corporations in the United States and Foreign Countries. First Premium wherever exhibited, and hundreds of testimonials of the highest character. A NEW SIZE FOR PROSPECTING AND LABORATORY USE. ALL STONE CRUSHERS not made or licensed by us, containing vibratory convergent jaws actuated by a revolving shaft and fly-wheel, are infringements on our patent, and makers and users of such will be held accountable. Address: BLAKE CRUSHER CO., New Haven, Conn.

PULMOCURA AN ABSOLUTE AND UNFAILING REMEDY FOR CONSUMPTION and all other diseases of the Lungs and Throat. Mailed free on receipt of \$1. A. A. MARTIN, Pulmocura Man'g Co., sole depot for the U. S., 60 East 12th St., cor. Broadway, New York.

RIVAL STEAM PUMPS. JOHN H. MCGOWAN & CO. 35 & 47 WARD ST. CINCINNATI OHIO. Soft, Strong, and Smooth CASTINGS Plain, Galvanized, Iron or Brass. Also patterns and models. Light work a specialty. LIVINGSTON & CO., Iron Founders, Pittsburg, Pa.

NEW STEEL HORSE SHOE. With Level Spring Platform—Continuous Calk. The best in the world. Cures Tender and Contracted Feet, Corns, Interfering, Quarter-crack Lameness, and all evils resulting from the use of the common shoe. Responsible men can make money selling this Shoe. Send for pamphlet. Trial set with nails, \$1.00. To measure, place foot on paper, and draw pencil around. The JOHN D. BILLINGS PATENT HORSE SHOE COMPANY 265 Broadway, New York.

THE BEST STEAM PUMP in AMERICA More than 4500 in use. THE DEANE Deane Steam Pump Works 85 LIBERTY ST. NEW YORK. Made by HOLYOKE MACHINE CO. Send for reduced Price List.

Small Tools of all kinds; GEAR WHEELS, parts of MODELS, and materials of all kinds. Catalogues free. GOODNOW & WIGHTMAN, 176 Wash'n St., Boston, Mass.

Fine Pamphlets printed for 75c. a Page per 1,000. 1,000 Fine 9x12 Circulars, \$2.50. Price list or estimate and samples for stamp. 250 Hill Heads, \$1. "Local" Printing House, Silver Creek, N. Y. \$77 a Month and expenses guaranteed to Agents. Outfit free. SHAW & Co., AUGUSTA, MAINE.

LEFFEL WATER WHEELS. With recent improvements. Prices Greatly Reduced. 7000 in successful operation. FINE NEW PAMPHLET FOR 1877, Sent free to those interested. James Leffel & Co., Springfield, O. 109 Liberty St., N. Y. City.

Steel Stamps. N.Y. STENCIL WORKS, 87 Nassau St. N.Y.

LAP WELDED CHARCOAL IRON Boiler Tubes, Steam Pipe, Light and Heavy Forgings, Engines, Boilers, Cotton Presses, Rolling Mill and Blast Furnace Work. READING IRON WORKS, 261 South Fourth St., Phila.

PHOSPHOR-BRONZE BEARINGS, PUMP-RODS, AND SPRING WIRE. Phosphor-Bronze. Apply to THE PHOSPHOR-BRONZE SMELTING CO., Limited, 208 Washington Ave., Philadelphia, Pa.

Lathes, Planers, Shapers Drills, Bolt and Gear Cutters, Milling Machines, Special Machinery. E. GOULD & EBERHARDT, Newark, N. J.

Paris, . . 1878 Australia, 1877 Phila., . . 1876 Santiago, 1875 Vienna, 1873

J. A. FAY & CO'S WOOD WORKING MACHINERY was awarded at the Paris Exposition over all competitors THE GOLD MEDAL OF HONOR. Also highest award at Phila., Santiago, Australia, and Vienna. It is Original in Design, Simple in Construction, Perfect in Workmanship, Saves Labor, Economizes Lumber, and Increases products of the highest standard of Excellence. Railroad, Furniture, and Agricultural Implement Shops, Planing Mills, etc., equipped at short notice, and the lowest cash prices. Send for Circulars. J. A. FAY & CO., Cincinnati, Ohio, U. S. A. L. F. STANDISH & CO., Screw Manufacturers, Builders of Small Machinery and Fine Tools. 26 Artisan St., New Haven, Ct.

NEW YORK BELTING AND PACKING COMPY. The Oldest and Largest Manufacturers of the Original SOLID VULCANITE EMERY WHEELS. All other kinds Imitations and Inferior. Our name is stamped in full upon all our standard BELTING, PACKING, and HOSE. Address NEW YORK BELTING AND PACKING CO., NEW YORK. Emery Wheel. JOHN H. CHEEVER, Treas.

THE SEVENTH Cincinnati Industrial Exposition. Opens for the reception of goods August 20th. Opens to the public September 10th, and continues open until October 11th, in the NEW PERMANENT BUILDINGS ERECTED FOR THE PURPOSE. Machinery Tested and Fully Reported upon. Send for Rules and Premium Lists after April 1. H. McCOLLUM, Sec'y.

THE FORSTER-FIRM GOLD AND SILVER AMALGAMATING COMPY of Norristown, Pa., will grant state rights or licenses on easy terms. This system works up to assay, and recovers the mercury rapidly. Apply as above. THOMAS'S CONCENTRATED DYE Stuffs. (138 Recipes SENT GRATIS.) (See SCIENTIFIC AMERICAN SUPPLEMENT, March 15, '79. Address N. SPENCER THOMAS, Elmira, N. Y.)

Baker Rotary Pressure Blower. (FORCED BLAST) Warranted superior to any other. WILBRAHAM BROS. 2818 Frankford Ave. PHILADELPHIA

"The 1876 Injector." Simple, Durable, and Reliable. Requires no special valves. Send for illustrated circular. WM. SELLERS & CO., Phila.

PATENT COLD ROLLED SHAFITING. The fact that this shafting has 75 per cent. greater strength, a finer finish, and is truer to gauge, than any other in use renders it undoubtedly the most economical. We are also the sole manufacturers of the CELEBRATED COLLINS' PAT. COUPLING, and furnish Pulleys, Hangers, etc., of the most approved styles. Price list mailed on application to JONES & LAUGHLIN, Try Street, 2d and 3d Avenues, Pittsburgh, Pa. 190 S. Canal Street, Chicago, Ill., and Milwaukee, Wis. Stocks of this shafting in store and for sale by FULLER, DANA & FITZ, Boston, Mass. Geo. Place Machinery Agency, 121 Chambers St., N. Y.

VEGETABLE AND FLOWER SEEDS WE SELL EVERYTHING FOR THE GARDEN Descriptive Catalogues of 175 pages sent Free PETER HENDERSON & CO. 35 Cortlandt St., New York. FLOWER AND FRUIT PLANTS

NEW METHOD OF ENGRAVING Moss Process. Photo Engraving Co. 67 Park Place, New York. L. SMITH HOBART, President. JOHN C. MOSS, Superintendent.

TYPE-METAL RELIEF PLATES. A SUPERIOR SUBSTITUTE FOR WOOD-CUTS AT MUCH LOWER PRICES.

Persons desiring illustrations for Books, Newspapers, Catalogues, Advertisements, or for any other purposes, can have their work done by us promptly and in the best style. Our Relief Plates are engraved by photo-chemical means; are mounted on blocks type-high ready for use on any ordinary press, and will wear longer than the common stereotype plates. They have a perfectly smooth printing surface, and the lines are as deep, as even, and as sharp as they could possibly be cut by hand. Electrotypes may be made from them in the same manner as from wood-cuts. Copy. The engraving is done either from prints or pen-drawings. Almost all kinds of prints can be re-engraved directly from the copy, provided they be in clear, black lines or stipple, and on white or only slightly tinted paper. Pen drawings, suitable for engraving by us, must be made with thoroughly BLACK ink, on smooth, white paper. They should usually be made twice the length and twice the width of the plates desired. When such drawings cannot be furnished us, we can produce them from photographs, pencil sketches, or designs of any kind accompanied with proper instructions. Photographs taken in the usual way, and of any convenient size, we can use. Change of Size.—Wood-cut prints of the coarser kind may often be reduced to half their lineal dimensions, while others will admit of very little reduction, and some of none at all. Most lithographic and steel-plate prints will admit of no reduction. Very fine prints of any kind may be enlarged moderately without detriment. Any prints which cannot be satisfactorily reduced or enlarged may be redrawn and thus brought to any desired size. In all cases of reduction and enlargement, the relative proportions remain unchanged. Proofs.—Whenever desired, we will furnish tintype proofs of the drawings made by us, for approval or correction, before engraving. A printed proof is furnished with each plate. Time.—We cannot usually engage to fill an order for a single plate in less than from three to six days; larger orders will require longer time. Estimates will be promptly furnished when desired. That these may be definite and correct, the copy to be used—whether print, photograph, sketch, or drawing—should always be submitted for our examination, together with a distinct statement of the size of plate wanted, and of any other details to be observed. Terms.—To insure attention, all orders must be accompanied by an advance of half the price charged, the balance to be paid on delivery. Electrotyping and Printing.—We have recently added to our establishment excellent facilities for making electrotypes, and also three power presses specially fitted for printing plates of all sizes in the finest manner. Artificial Light.—We have just introduced this most important facility, which enables us to prosecute our work in cloudy weather, and to push forward hurried orders in the night. References.—Our plates are now used by the principal publishers in this city, and by most of the leading houses in every State in the Union. Our General Circular contains a few specimens of the various kinds of our work, and will be sent on receipt of stamp. We have just prepared five special circulars, as follows: No. 1. Portraits and Figures. " 2. Buildings and Landscapes. " 3. Machinery and Apparatus. " 4. Maps, Autographs, and Ornamental Lettering. " 5. Reproductions from Wood-Cuts, Steel-Plate Prints, and Lithographs. These will be furnished at ten cents each.

Advertisements.

Issue Page, each insertion --- 75 cents a line. Back Page, each insertion --- \$1.00 a line. (About eight words to a line.) Engravings may head advertisements at the same rate per line, by measurement, as the letter press. Advertisements must be received at publication office as early as Thursday morning to appear in next issue.

ADJUSTABLE INCLINE PRESSES. STILES & PARKER PRESS CO., Middletown, Conn.

CATALOGUE OF
B. K. BLISS & SONS
HANDBOOK
 for the **FARM & GARDEN**
 SMALL FRUITS AND GARDEN REQUISITES

136 pages beautifully illustrated, mailed to all applicants enclosing 10 cents. Regular customers free. Bliss' Illustrated Amateur's Guide to the Flower and Kitchen Garden, with colored chromo; 216 pages, price 35 cents. Address **B. K. BLISS & SONS, P. O. Box 4129, New York City.**

TO LARGE CONSUMERS OF FINE LIGHT Malleable Iron Castings, we can offer special inducements in the way of VERY SUPERIOR QUALITY GUARANTEED, and at fair prices. Being our largest consumers and requiring the most perfect castings, other work is insured the same attention. **MALLOY, WHEELER & CO., NEW HAVEN, CONN.**

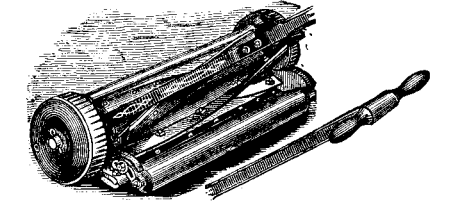

THE PHILADELPHIA LAWN MOWER Stands "Head of the Class." Descriptive Circulars and Price Lists sent on application. **GRAHAM, EMMEL & PASSMORE, Patentees and Manufacturers, 631 Market Street, Philadelphia, Pa.**

SHAFTING PULLEYS, HANGERS, etc. a specialty. Send for Price List to **A. & F. BROWN, 51-53 Lewis Street, New York.**

AIR COMPRESSORS, HOISTING ENGINES AND OTHER MINING MACHINERY, MANUFACTURED BY **GRIFFITH & WEDGE, ZANESVILLE, OHIO.**

Mill Stones and Corn Mills. We make Burr Millstones, Portable Mills, Smut Machines, Packers, Mill Picks, Water Wheels, Pulleys, and Gearing, specially adapted to Flour Mills. Send for catalogue. **J. T. NOYE & SON, Buffalo, N. Y.**

HOW TO SELL PATENTS.—This little book fully explains how all patents can be sold for good prices. Price 25 cents. **L. D. SNOOK, Barrington, Yates Co., N. Y.**

Pond's Tools, Engine Lathes, Planers, Drills, &c. **DAVID W. POND, Worcester, Mass.** EDMUND DRAPER, Manufacturer of First-class Engineers' Instruments. Established in 1830. **226 Pear St., Phila., Pa.**

J. LLOYD HAIGH, Manufacturer of

WIRE ROPE

of every description, for Railroad and Mining Use, Elevators, Derricks, Rope Tramways, Transmission of Power, etc. No. 81 John St., N. Y. Send for price list. Plans and Estimates furnished for Suspension Bridges.

THE DINGEE & CONARD CO'S BEAUTIFUL EVER-BLOOMING ROSES
 THE BEST IN THE WORLD.
 Our Great Specialty is growing and distributing these Beautiful Roses. We deliver Strong Pot Plants, suitable for immediate bloom, safely by mail at all post-offices. Extraordinary Varieties, your choice, all labeled, for \$1, 12 for \$3; 19 for \$3; 26 for \$4; 35 for \$5; 75 for \$10; 100 for \$13. Send for our New Guide to Rose Culture—60 pages, elegantly illustrated—and choose from over Five Hundred Finest Sorts. Address **THE DINGEE & CONARD CO., Rose Growers, West Grove, Chester Co., Pa.**

HOW TO SELL PATENTS. We send our instruction, containing valuable information, free. Send us your address. **GEO. C. TRACY & Co., Cleveland, O.**

NO MORE RHEUMATISM OR GOUT ACUTE OR CHRONIC SALICYLIC SURE CURE.

Manufactured only under the above Trade-Mark, by the **European Salicylic Medicine Co., OF PARIS AND LEIPZIG.**

IMMEDIATE RELIEF WARRANTED. PERMANENT CURE GUARANTEED. Now exclusively used by all celebrated Physicians of Europe and America, becoming a Staple, Harmless, and a Reliable Remedy on both continents. The Highest Medical Academy of Paris report 95 cures out of 100 cases within three days. Secret—The only dissolver of the poisonous Uric Acid which exists in the Blood of Rheumatic and Gouty Patients. \$1.00 a Box; 6 Boxes for \$5.00. Sent to any address on receipt of price. EXPOSED BY PHYSICIANS. SOLD BY ALL DRUGGISTS. Address

WASHBURNE & CO., Only Importers' Depot, 212 Broadway, cor. Fulton St., New York.

19th Annual Statement of the EQUITABLE Life Assurance Society of the U. S.
HENRY B. HYDE, President.
 AMOUNT OF LEDGER ASSETS, JAN. 1, 1878, \$32,477,991 87
 Less Depreciation in Government Bonds, and Appropriation to meet any depreciation in other assets..... 369,553 27
INCOME..... 32,108,438 60
 8,217,943 24
DISBURSEMENTS.
 Paid Policy Holders for Claims by Death, Dividends, Surrender Values, Discounted and Matured Endowments and Annuities.. 4,935,171 43
 Other Disbursements as per extended statement..... 1,195,841 88
NET CASH ASSETS, December 31, 1878..... \$34,195,568 53
ASSETS.
 Bonds and Mortgages..... \$12,437,584 93
 Risks assumed in 1878, 6,115 Policies, assuring \$21,440,213 00.
 N.B.—For the details of the above statement, see the Society's "Circular to Policy Holders," and other publications for 1879.
JAMES W. ALEXANDER, Vice-President.
E. W. SCOTT, Superintendent of Agencies.
SAMUEL BORROWE, Secretary.

LA CAISSE GENERALE OF PARIS (FRANCE)
FIRE INSURANCE EXCLUSIVELY.
 PAID UP CAPITAL..... \$1,458,007 78
 NET SURPLUS, DEC. 31, 1878..... 530,056 86
 CASH ASSETS IN U. S. JAN. 1, 1878..... 427,881 28
 NET ASSETS IN U. S. JAN. 1, 1878..... 2,220,000 00
TRUSTEES IN NEW YORK:
 LOUIS DE COMEAU, Esq., of De Rham & Co.
 CHAS. COUDEBERT, JR., Esq., of Coudebert Bros.
 CHAS. RENAULT, Esq., of Renault, Francois & Co.
JULIEN LE CESNE, Resident Secretary.
T. J. TEMPLE, Manager for the Middle States.
WESTERN UNION BUILDING, N. Y.

BOLT CUTTERS. Send for Catalogue of **Schlenker's Automatic Bolt Cutters and Screw Cutting Machines.** **HOWARD IRON WORKS, Buffalo, N. Y.**

BIG PAY to sell our Rubber Printing Stamps. Samples free. **Taylor Bros. & Co., Cleveland, O.**

THE Eclipse Engine
 Furnishes steam power for all Agricultural purposes, Draining Saw Mills, and for every use where a first-class and economical Engine is required. Eleven first-class premiums awarded, including Centennial '76. Refer to No. 1, issue of '77, No. 14, issue of '78, of SCIENTIFIC AMERICAN, for Editorial illustrations.
FRICK & CO., Waynesboro, Franklin Co., Pa.
 When you write please name this paper.

THE CAMERON STEAM PUMP, Also known as the "SPECIAL" PUMP, is the standard of excellence at home and abroad. For Price Lists, address **CAMERON PUMP WORKS, Foot East 23d Street, New York.**

SHEPARD'S CELEBRATED \$50 Screw Cutting Foot Lathe. Foot and Power Lathes, Drill Presses, Scrolls, Circular and Band Saws, Saw Attachments, Chucks, Mandrels, Twist Drills, Dogs, Calipers, etc. Send for catalogue of outfits for amateurs or artisans.
H. I. SHEPARD & CO., 331, 333, 335, & 337 West Front Street, Cincinnati, Ohio.
 ESTABLISHED 1844.
JOSEPH C. TODD, ENGINEER and MACHINIST. Flax, Hemp, Jute, Rope, Oakum and Bagging Machinery, Steam Engines, Boilers, etc. I also manufacture Baxter's New Portable Engine of 1877. Can be seen in operation at my store. A one horse-power portable engine, complete, \$125; two horse-power, \$225; two and a half horse-power, \$275; three horse-power, \$375. Manufactured exclusively by **J. C. TODD,** 10 Barclay St., New York, or Paterson, N. J.

Send for Catalogue.

THE LEHIGH VALLEY EMERY WHEEL CO., WEISSPORT, Carbon Co., Pa.
 Manufacturers of Wheels and Machines.

RUFFNER & DUNN, Patentees and Sole Manufacturers of the Excelsior Steel Tube Cleaners. Price \$1.00 per inch. Send for circular. **SCHUYLKILL FALLS, PHILA., PA.**

WOODWORTH SURFACE PLANERS, \$125. Planers and Matchers, \$350. **S. C. HILLS, 78 Chambers Street, New York.**

The Columbia Bicycle, Made by **THE POPE M'FG CO.,** 89 Summer Street, Boston. A practical road machine, easy to learn to ride, and when mastered one can beat the best horse in a day's run over an ordinary road. Send 3c. stamp for price list and 24-page catalogue with full information.

WETHERILL & BROTHER, PHILADELPHIA.

PURE WHITE LEAD.

ROCK DRILLS. National Drill and Compressor Co., 95 LIBERTY ST., NEW YORK. AIR COMPRESSORS to be run by Steam, Water Power, or Belt.

ELEVATORS HAND POWER AND HYDRAULIC FREIGHT & PASSENGER SHAFTING PULLEYS & HANGERS **S. GRAVES & SON ROCHESTER N.Y.**

BOILER COVERINGS. WITH THE "AIR SPACE" IMPROVEMENTS. **THE CHALMERS-SPENCE CO.,** Foot E. 9th St., New York. Sole owners of the Air Space Patents.

THE TANITE CO., STROUDSBURG, PA.
EMERY WHEELS AND GRINDERS. LONDON—9 St. Andrews St., Holborn Viaduct, E. C. LIVERPOOL—42 The Temple, Dale St. GEO. PLACE, 121 Chambers St., New York Agent.

ROCK DRILLING MACHINES AND AIR COMPRESSORS. MANUFACTURED BY **BURLEIGH ROCK DRILL CO. FITCHBURG MASS.** SEND FOR PAMPHLET.

PATENTS at AUCTION. Regular Monthly Sales. For terms, address N. Y. PATENT EXCHANGE, 67 Liberty Street, New York.

Holly's Improved Water Works. Direct Pumping Plan. Combines, with other advantages, over older systems, the following: 1. Secures by variable pressure a more reliable water supply for all purposes. 2. Less cost for construction. 3. Less cost for maintenance. 4. Less cost for daily supply by the use of Holly's Improved Pumping Machinery. 5. Affords the best fire protection in the world. 6. Largely reduces insurance risks and premiums. 7. Dispenses with fire engines, in whole or in part. 8. Reduces fire department expenses. For information by descriptive pamphlet, or otherwise, address the **HOLLY MANUFACTURING CO., Lockport, N. Y.**

Every Man HIS OWN Printer. **THE \$3 Press** Prints in-boards, etc. (Self-inker \$45) 9 Larger sizes For business, pleasure, young or old Catalogue of Presses, Type, Etc., for 2 stamps. **KELSEY & Co. Meriden, Conn.**

Pyrometers. For showing heat of Boiler Flues, Superheated Steam, Oil Stills, etc. **HENRY W. BULKLEY, Sole Manufacturer,** 149 Broadway, N. Y.

MACHINISTS' TOOLS. NEW AND IMPROVED PATTERNS. Send for new illustrated catalogue. **Lathes, Planers, Drills, &c.** **NEW HAVEN MANUFACTURING CO., New Haven, Conn.**

HERMETICAL SANITARY CLOSET GUARANTEED ABSOLUTELY WATER-TIGHT. SEND FOR CIRCULAR. **JOHN S. LENG, 4 FLETCHER ST. N.Y.**

Cigar Box Lumber, MANUFACTURED BY OUR NEW PATENT PROCESS. **The Best in the World.** **SPANISH CEDAR, MAHOGANY, POPLAR.** Also thin lumber of all other kinds, 1/4 to 1/2 in., at corresponding prices. All qualities. Equal in all respects to any made, and at prices much under any to be obtained outside of our establishment. Send for price list. **GEO. W. READ & CO.,** 156 to 200 Lewis Street, N. Y.

BOGARDES' PATENT UNIVERSAL ECCENTRIC MILLS.—For grinding Bones, Ores, Sand, Old Crucibles, Fire Clay, Guanos, Oil Cake, Feed, Corn, Corn and Cob, Tobacco, Snuff, Sugar, Salts, Roots, Spices, Coffee, Coconut, Flaxseed, Asbestos, Mica, etc., and whatever cannot be ground by other mills. Also for Paints, Printers' Inks, Paste Blacking, etc. **JOHN W. THOMSON, successor to JAMES BOGARDES,** corner of White and Elm Sts., New York.

THE WATSON PUMP FOR ARTESIAN OR DEEPWELL ROD IN DIRECT LINE MACHINE SIMPLE EFFICIENT. 1608 S. FRONT ST. JAMES WATSON PHILA.

FARM LAW. ADDRESS OF HON. ED-MUND H. BENNETT, delivered before the Massachusetts State Board of Agriculture. This is an essay embracing complete and practical information, valuable not only to the farmer but to every one who has to do with a Farm. Bargains that are not Binding; Boundaries, and where they are in Streams, Ponds, lakes, or on the Sea-shore; what a Deed of a Farm includes; Rights in the Road. Farm Fences; their Legal Height, etc. Railway Fences. Stray Cattle; Cattle on Railways; Impounding Cattle. The Farmer's Liability for his Animals. The Law on the Dog. The Farmer not Liable for his Dogs. Water Rights and Drainage; Damming; Diverting the Course of a Stream. Surface Water; Underground Water. Trespassing, in Summer and in Winter. Hunting and Fishing. Fruit Trees on Boundary Lines, etc., etc. Contained in SCIENTIFIC AMERICAN SUPPLEMENT 166. Price 10 cents.

WROUGHT IRON BEAMS & GIRDERS
THE UNION IRON MILLS, Pittsburgh, Pa. Manufacturers of improved wrought iron Beams and Girders (patented). The great fall which has taken place in the prices of Iron, and especially in Beams used in the construction of FIRE PROOF BUILDINGS, induces us to call the special attention of Engineers, Architects, and Builders to the undoubted advantages of now erecting Fire Proof structures; and by reference to pages 52 & 54 of our Book of sections—which will be sent on application to those contemplating the erection of fire proof buildings—THE COST CAN BE ACCURATELY CALCULATED, the cost of Insurance avoided, and the serious losses and interruption to business caused by fire; these and like considerations fully justify any additional first cost. It is believed, that, were owners fully aware of the small difference which now exists between the use of Wood and Iron, in many cases the latter would be adopted. We shall be pleased to furnish estimates for all the Beams complete, for any specific structure, so that the difference in cost may at once be ascertained. Address **CARNEGIE, BROS. & CO., Pittsburgh, Pa.**

ICE AT \$1.00 PER TON. **The PICTET ARTIFICIAL ICE CO., LIMITED,** Room 51, Coal and Iron Exchange, P. O. Box 3083, N. Y.

H.W. JOHNS' ASBESTOS
 Liquid Paints, Roofing, Boiler Coverings, Steam Packing, Sheathings, Fire Proof Coatings, Cements, &c. SEND FOR DESCRIPTIVE PRICE LIST. **H. W. JOHNS M'FG CO. 87 MAIDEN LANE, N.Y.**

\$10 to \$1000 Invested in Wall St. Stocks makes fortunes every month. Books sent free explaining everything. Address **BAXTER & CO., Bankers, 17 Wall St., N.Y.**

THE "Scientific American" is printed with CHAS. FENEU JOHNSON & CO.'S INK. Tenth and Lombard Sts., Philadelphia, and 59 Gold St., New York.