

SCIENTIFIC AMERICAN

A WEEKLY JOURNAL OF PRACTICAL INFORMATION, ART, SCIENCE, MECHANICS, CHEMISTRY, AND MANUFACTURES.

Vol. XXXV.--No. 19.]
[NEW SERIES.]

NEW YORK, NOVEMBER 4, 1876.

[\$3.20 per Annum.
[POSTAGE PREPAID.]

CURIOUS BOATS AT THE CENTENNIAL EXPOSITION.

There is no one class of exhibits at the Centennial Exposition more completely represented, and yet more widely scattered, than that which includes vessels and boats of all kinds. There is a superb collection of models of men of war, fishing craft, and small boats in the United States

Building. In Machinery Hall, there are elaborate models of ocean steamers, ironclads, race boats, ice boats, canoes, and the admirable exhibit of the Massachusetts Marine, which includes vessels of every conceivable description, from skiffs to fast sailing clippers. In an out-of-the-way corner of one of the mineral annexes of the Main Building, a curi-

ous display of Chinese junks may be found; interspersed through all the foreign departments are models of the vessels peculiar to the different countries. In the Agricultural Building, there is another collection of fishing boats, a large portion of which is in the Norwegian section: and thus,
Continued on page 292.

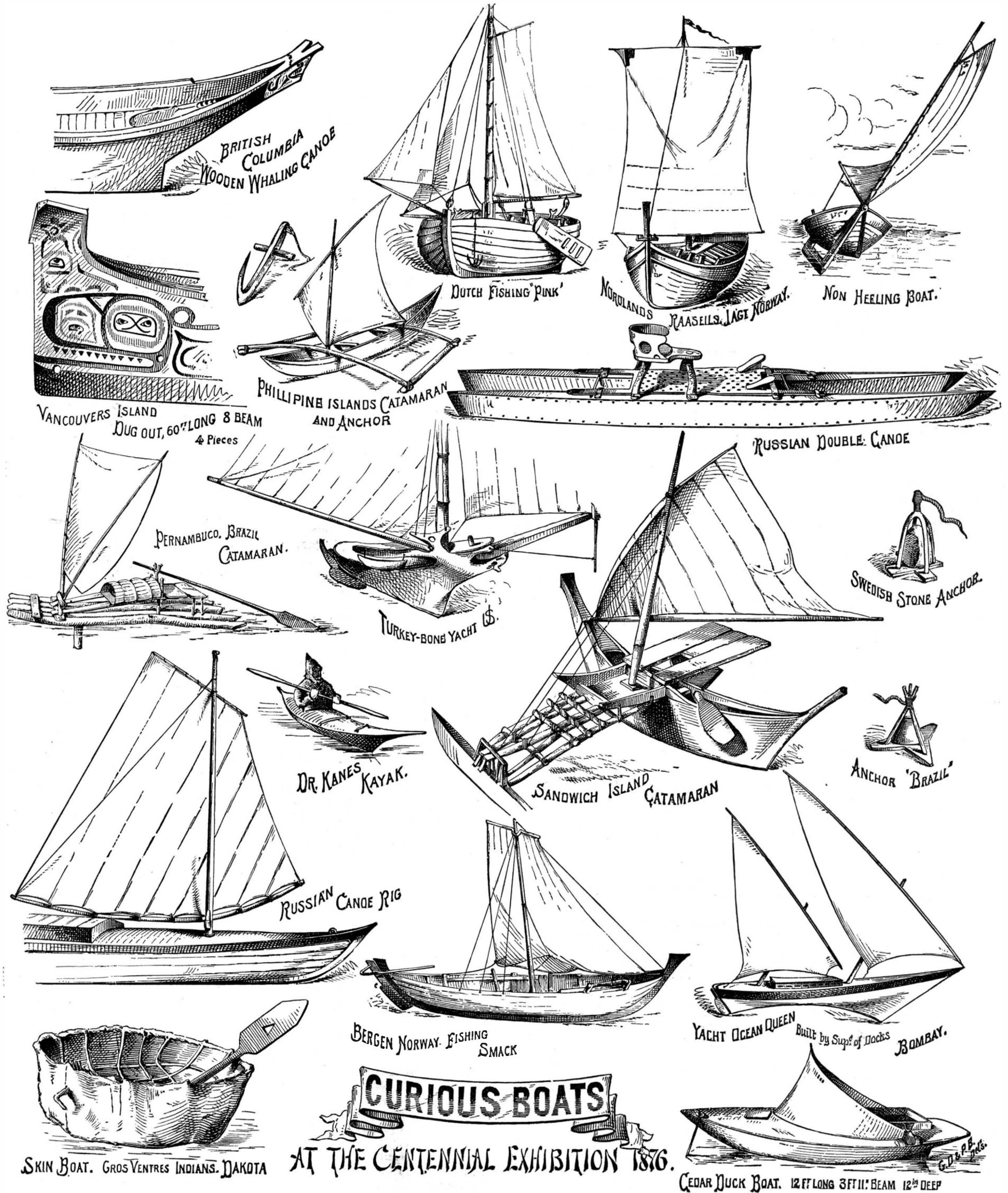

CURIOUS BOATS
AT THE CENTENNIAL EXHIBITION 1876.

Scientific American.

ESTABLISHED 1846.

MUNN & CO., Editors and Proprietors.

PUBLISHED WEEKLY AT NO. 87 PARK ROW, NEW YORK.

O. D. MUNN.

A. E. BEACH.

TERMS FOR THE SCIENTIFIC AMERICAN.

One copy, one year, postage included.....\$3 20
One copy, six months, postage included..... 1 60

Club Rates.

Ten copies, one year, each \$2 70, postage included.....\$27 00
Over ten copies, same rate each, postage included..... 2 70

The postage is payable in advance by the publishers, and the subscriber then receives the paper free of charge.

NOTE.—Persons subscribing will please to give their full names, and Post Office and State address, plainly written. In case of changing residence state former address, as well as give the new one. No changes can be made unless the former address is given.

Scientific American Supplement.

A distinct paper from the SCIENTIFIC AMERICAN, but of the same size and published simultaneously with the regular edition.

TERMS.

One year by mail.....\$5 00
SCIENTIFIC AMERICAN and SUPPLEMENT, to one address..... 7 00
Single Copies..... 10

The safest way to remit is by draft, postal order, or registered letter. Address MUNN & Co., 87 Park Row, N. Y.

Subscriptions received and single copies of either paper sold by all the news agents.

VOLUME XXXV., No. 19. [NEW SERIES.] Thirty-first Year.

NEW YORK, SATURDAY, NOVEMBER 4, 1876.

Contents.

(Illustrated articles are marked with an asterisk.)

Academy of Sciences..... 289
Alcohol, new test for..... 289
Answers to correspondents..... 299
Ants, to exterminate..... 294
Apple, curious..... 293
Arms for Russia..... 297
Astronomical notes..... 297
Atoms and molecules, sizes of, etc..... 293
Australian gum tree..... 297
Bell, note of a (21)..... 299
Belts, large..... 292
Boat, a canvas (20)..... 293
Boats at the Centennial*..... 299
Boats, speed of (24)..... 300
Boiler consumption of water (6)..... 299
Boilers for small engines (13)..... 299
Boilers, pressure in (22)..... 299
Bread making, aerated..... 294
Bridge cable, the East river..... 293
Bugs or hemiptera, the*..... 295
Burbot, the*..... 295
Business and personal..... 299
Canaries, training..... 291
Catamaran, the (18)..... 299
Cat's eye, the..... 293
Centennial awards, the..... 293
Centennial attendance at the..... 293
Centennial, boats at the*..... 297
Centennial, minerals at the..... 296
Centennial main building, the..... 293
Centennial notes*..... 293
Chair and secretary..... 293
Chimney and shaft..... 293
Coffee as a disinfectant (28)..... 300
Cold spells (2)..... 299
Cuculifera, to dispose of..... 299
Dispute, how to settle a..... 293
Electric circuits (4)..... 293
England's dilemma..... 293
Eyes, nearsighted (15)..... 299
Fire on the hearth..... 299
Floors, vibrating (12)..... 299
Fuse, explosion (3)..... 299
Germany at the Centennial..... 297
Governors, electric engine..... 292
Heating and ventilation (2)..... 292
Hemiptera or bugs, the*..... 295
Huxley, Prof., and Dr. Taylor..... 288

THE SCIENTIFIC AMERICAN SUPPLEMENT.

Vol. II., No. 45.

For the Week ending November 4, 1876.

TABLE OF CONTENTS.

I. THE INTERNATIONAL EXHIBITION OF 1876. With 20 figures.—Exhibits of Steam Boilers, with 7 figures.—The Exeter Boiler, Harrison Boiler, Babcock & Wilcox Boiler, Anderson Boiler, Firminich Boiler.—The Sicksels Steam Cut-Off.—Exhibits of the Stephens Institute of Technology, with 10 illustrations, namely, Linear Dividing Engine, Gonionometer, Vertical Lathes for Screens, Autographic Testing Machine, Oil Tester, Dynamometer, Measuring Instrument for Water Streams, Large Spectroscope, Resonator, Stevens Historical Steamboat Engine.—Ramsay's Car Truck Shifter, 3 figures.
II. ENGINEERING AND MECHANICS.—The Early Steam Engines of the United States, with two pages of engravings, showing the first Engine of the Philadelphia Water Works and their Wooden Steam Boilers. Construction, etc.—Compressed Air Motors, using Air at 1,500 lbs. per inch.—The Morse Alphabet for Naval Signalling.—Opening of the First Railway in China, 1 engraving.—Locomotive Tests, Boston and Albany Railway.—Strength and Fracture of Cast Iron.—Strength of Concrete.—The Stobross Docks.—Spring Fenders for Pier Heads.—Manufacture of Fire Bricks.—The Haswell System of Pressure Forging, by J. O. BUTLER.—Manufacture of Planished Straight Round Bars, by EDMUND BUTLER.—Manufacture of Glass in Connection with Blast Furnaces, by B. BRITTON.—The Longest Bridge in the World.—Improvement in Hot Blast Stoves, with 3 figures.—Improved Ore Furnace, 1 figure.—Candell's Mineral Dresser, 1 figure.—Machine for Beveling Circular Plates, 2 figures.—New Lubricator, 1 figure.—Novelty in Toothed Gearing, 1 figure.—Baxter's Automatic Grain-Weighing Machine, 1 figure.—New Machine for Drying Grain, 2 figures.—The Atlantic Steam Fleet.
III. TECHNOLOGY.—How to make Aniline Black Inks.—How to make Copying Inks.—How to make Powder and Tablet Inks.—Process for New Colors.—Ornamental Silver Lamp Pendant, 1 engraving.—Phosphor-Bronze, its Various Uses and Value in the Arts.
IV. LESSONS IN MECHANICAL DRAWING, by Professor MACCORN; No. 25. One and a half pages of illustrations.
V. CHEMISTRY AND METALLURGY.—Detection of Artificial Coloration in Wines.—New Process for the Estimation of Potassa, by M. A. CARNOT.—Method of Ascertaining Copper in Cast Iron.
VI. AGRICULTURE, HORTICULTURE, ETC.—Value of Carrots for Horses and Cattle.—Temperature in Relation to the Growth of Plants.—Grape Management and Pruning.—How to Grow Ferns in Cases.
VII. MISCELLANEOUS.—Historical Treasures in the Scientific Loan Collection Exhibition, London, 8 engravings, namely: Parent Engine of Steam Navigation; Newcomen's Steam Engine; The Comet, the first Steamboat on the Clyde, 3 figures; Original Engine of the Comet; The Locomotive "Puffing Billy"; Von Guericke's Air Pump.—The Corona Line in the Solar Spectrum.—Vitricous Rocks.—Examination of Sea Bottom from Balloons.—Weather Insurance.

The Scientific American Supplement

is a distinctive publication issued weekly; every number contains 16 octavo pages, with handsome cover, uniform in size with SCIENTIFIC AMERICAN. Terms of subscription for SUPPLEMENT, \$5.00 a year, postage paid, to subscribers. Single copies, 10 cents. Sold by all news dealers throughout the country.

All the numbers of the SUPPLEMENT from its commencement, January 1, 1876, can be supplied; subscriptions date with No. 1 unless otherwise ordered.

MUNN & CO., PUBLISHERS,

87 Park Row, New York.

Single copies of any desired number of the SUPPLEMENT sent to any address on receipt of 10 cents.

DR. TAYLOR VS. PROFESSOR HUXLEY.

As a rule, it is a waste of time to pay any attention to the excursions of any man into unfamiliar fields of knowledge, however great his reputation for learning may be in other directions. A man may be an authority in Hebrew history, yet densely ignorant of the events of mediæval Europe. He may be chief among chemists, yet a beginner in biology, and entirely out of his element in mechanics. When such a specialist attempts to settle questions in departments other than his own, he is pretty sure to accomplish little else than the exposure of his own lack of knowledge. Even more certain to go wrong is the man who ventures into a field of knowledge in which the means and methods of study, the kind of evidence, the spirit of investigation, and the purpose of the work are each and all unlike those he is used to. The mental habits of the trained theologian, for example, are quite the reverse of those of the trained scientist. The one proceeds, calmly, dispassionately, and sensibly, to investigate actual existences, conditions, relations, and occurrences. The result may be more or less advantageous to him and to his fellows; but he is not personally responsible for it, whatever it may be, since no one can justly blame or punish him, here or hereafter, for finding things as they are. The theologian, on the contrary, deals with matters of emotion, aspiration, fancy. His materials are ever varying feelings and equally unstable imaginations. His things are words, often from languages vaguely understood, or technical phrases concerning the import of which there is no agreement. And the issues at stake are of transcendent importance—infinite felicity or eternal woe to such as assent or deny. To him authority, human or divine, is everything: tradition is almost omnipotent, and the penalty of independent thought is excommunication, the alienation of friends and associates, and, mayhap, personal damnation. And he naturally carries with him the same habits of thought, the same incapacity for unprejudiced and impartial investigation of realities, the same inability to appreciate the logic of facts, whenever he enters the scientific field as a self-elected umpire or dictator. Consequently his utterances therein are pretty certain to be valuable only as so many additions to the already over-abundant supply of illustrations of learned foolishness and of the uselessness of metaphysical methods for the advancement of real knowledge.

These remarks have been suggested by the labored attempt of the Rev. Dr. W. M. Taylor to break the force of Professor Huxley's lectures on evolution. Dr. Taylor is a gentleman of considerable eminence in the theological world: but that only makes the more ludicrous his Quixotic attack upon a purely imaginary Professor Huxley, in the course of which he exhibits an utter misapprehension of the scope and purpose of the real professor's remarks, and the most thorough-going ignorance of the range, amount, and quality of the evidence bearing on the question of evolution.

He is off the track from the start, assuming that Professor Huxley pretended to give a demonstration of the hypothesis of evolution, and that his lectures contained all the evidence to be produced in its support. The single fact that Professor Huxley promised no more than a popular illustration of certain lines of evidence bearing more or less distinctly and forcibly upon the hypothesis of evolution, and directly declared that it was no part of his purpose to enable any one to pronounce upon the truth or falsity of the doctrine, sufficiently proves the irrelevancy of four fifths of the pretended criticism. Professor Huxley did not promise nor attempt to "demonstrate" evolution, but merely to indicate the kind of historical evidence the theory demanded, and how geology was meeting the demand. To have recited all the evidence of this sort in the possession of Science would have required weeks or months instead of hours; while the evidence derived from existing conditions and relations in the world of animal and vegetable life would require an allowance of time not less liberal.

The remaining fifth of the two columns of the Tribune, which Dr. Taylor devotes to the destruction of the theory of evolution as Professor Huxley did not present it, comprises a curious array of misstatements, misconceptions, and absurdities, which we should like to traverse at length, but can merely sample for lack of space. No better evidence could be asked of the reverend doctor's incapacity for the task he has undertaken than is found in the following assertion, which may be a misapprehension, but certainly is a misstatement of the most ridiculous character. He says: "He (Professor Huxley) allows that species are persistent, and that there is little or nothing in the geologic records that sustains his position!"

After that, the reader will not be surprised at the assumption that the diversity of interpretation, "marvelous flexibility," etc., of Genesis is confined to the meaning of the word day; or that Professor Huxley craftily avoided the "fourth hypothesis" of creation—that is, creation in series, or successive creations in time—in spite of his positive exclusion of that view as unworthy of attention, it being unsupported by evidence of any kind, either scientific or scriptural.

But all these are as nothing, compared with the triumphantly funny demand: "If evolution rests on a basis as sure as astronomy, why do we not see one species passing into another now, even as we see the motions of the planets through the heavens? Why cannot its votaries foretell that, at a certain time and in a certain place, not too far from personal inspection by us, some modification in the structure of an animal or a plant shall occur, without any human intervention, even as astronomers predict the occurrence of a transit of Venus across the sun?"

Yet the man who is capable of perpetrating such a grand absurdity—absurd in what it asks, as well as in what it denies—really believes himself competent to pass upon a prob-

lem involving a vast amount of natural knowledge and no small degree of natural intelligence. And doubtless there are not a few who will accept his flourish of misplaced logic as conclusive against evolution, and rejoice with him that Professor Huxley's "imposition" has thereby been nailed to the counter "that it may not get into currency."

IRON AND STEEL WORKING IMPROVEMENTS.

We give in our this week's SUPPLEMENT a full abstract of a recent paper read before the Iron and Steel Institute, at Leeds, England, on the Haswell system of forging iron by hydraulic pressure, by Mr. J. O. Butler, and of the interesting discussion which followed. Much valuable practical information concerning iron forging was elicited. Among the speakers was Sir Joseph Whitworth, who gave some remarkable particulars concerning his operations in compressing molten steel. He stated, among other things, that he had lately completed a pair of steel screw shafts for the ship Inflexible. They were 283 feet long, weight 63 tons. A weight of 97 tons would, ordinarily, have been required; but by the compression of the molten steel, a saving in weight had been effected of 34 tons. In practice the fluid steel is subjected in the mold to a pressure of six tons, or 12,000 lbs., to the square inch.

This week's SUPPLEMENT also contains abstracts of papers, read before the Institute, on the "Straightening and Planishing of Round Bars," a process by which the scale, instead of being rolled in, is removed, and a smooth, clean surface produced, the bars being as finished and straight as if turned in a lathe.

Also an interesting paper on the "Utilization of Blast Furnace Slag, with its Heat, for the Manufacture of Glass." It appears from this paper that, by the addition of a few simple chemicals and apparatus, it is practicable to connect the profitable manufacture of glass with iron furnaces without in any manner interfering with the usual continuous operations of the blast furnace: the heat now lost being successfully applied to the production of the glass.

SOME THOUGHTS ON LABOR.

We have recently perused with much interest a little work entitled "Talks about Labor," written in a pleasant colloquial strain by Mr. J. N. Larned, of Buffalo, N. Y., in which the labor question is dealt with, in some respects, in a novel manner. The writer's main point is that political economy alone is not capable of dealing with the labor question, that the relations of capital and labor cannot be adjusted by abstract theorizing, but that the problem is constantly complicated by human needs, misfortunes, and passions, which must be considered. "We eke out now," he says, "a tyrannical and heartless theoretic economy with practical charities and generousities which make it tolerable. The change to be brought about is this: that we must reduce the generosity to a system, not of generosity but of justice in right." This, in the main, is but another form of expression for the counsels of moderation and regard for the rights of others that we have hitherto offered in considering cases of labor troubles; for we have long been persuaded that an equitable and permanent adjustment of the difficulties existing between employers and employed is to be reached, not by measures of coercion between the contending parties, or by like heroic treatment, but through the slow but sure judgment of society, brought about through the perception of the mean to which moderate action and opinion on both sides must approximate.

We cannot here follow the author through the various arguments which spring from the above proposition, and therefore at once pass to the remedy which he thinks likely to be most effectual against the strikes and lock-outs of the future. And this is a kind of limited coöperation between employers and employed, in which a system of dividends out of the profits is introduced to supplement the wages system. Then, it is urged, the working classes would begin to observe and apprehend the phenomena of the market out of which the laws of industrial economy are derived, and consequently would be inspired, from personal motives, to act in coöperation with the managers of capital. The idea so far is not new; and while we are by no means prepared to assert that it may not be practicable, past experience furnishes many instances of unsatisfactory results in its working. It was introduced in England by Messrs. Briggs & Son, of the Whitwood collieries, in 1865. This firm organized a limited company, and the men were made partners in the prosperity of the concern to a certain fair extent. The project met with the warmest favor from such men as John Stuart Mill and Thomas Hughes, but the workmen were dissatisfied with their gains, and it fell through. Samuel Smiles, in a recent work, says that the firms of Greening & Co., Manchester, and Fox, Head & Co., of Middlesborough, in the iron trade, also admitted their men to partnerships in profits. The latter firm started on this plan in 1866, and after nine years' trial the system was abandoned, last year. Sir Joseph Whitworth has announced his intention of testing the scheme, but his results, if any, are not known to us. Generally, however, so long as profits are large the men are contented; but when the market falls and gains are reduced, then the aggregate returns are still expected to remain at former figures. In the case of Fox, Head & Co., the unions kept forcing wages higher as profits decreased, until finally a successful demand for twenty per cent increase resulted in the abandonment of the plan.

Not long ago, a case came under our immediate observation where the men in a large factory deliberately forfeited a dividend, amounting to some ten per cent of the profits of a considerable period, and due within a few days, in order to

join their craft in a strike. Their action, as it was evident would be the case, resulted in failure, and they returned to work at the old wages minus any share in profits whatever.

Perhaps, however, if we couple with the coöperative plan the reforms which, the author points out, might be made among the trades' unions, the attainment of the desired result would be more probable. Mr. Larned's picture of the trades' unions of the future is an agreeable one. They might "take upon themselves the responsible guardianship of all the interests of the mechanic industries, each its own, fixing and maintaining a high standard of workmanship for every trade, graduating the mechanics in their several arts, and conferring diplomas and degrees as the colleges do, with such strictness and fairness that the classification of the union or guild would be recognized in the labor market: opening their doors to all new comers widely, without any bars except such as these standards of proficiency will set up, and aiming to individualize—not generalize—the compensation of labor in each department of work by individualizing the labor itself: looking always to the efficiency, the skill, the productive value of each man's work for the basis of the apportionment of dividends to him from the production to which he contributes." If this, we fear Utopian, outlook could be realized, that the trades' unions would become "institutions of splendid usefulness," there is no room for doubt.

One portion of Mr. Larned's work which will be read with especial interest is an excellent showing of the enormously increased and increasing productiveness of labor through the progress of invention of labor-saving machinery. From statistical data gathered by Dr. Engel, of the Prussian Statistical Bureau, relative to the aggregate steam power in use in the world, there are some 3½ millions horse power employed in stationary engines, and 10 millions in locomotive engines. All this is maintained without the consumption of animal food except to the extent of the food of the miners who dig the coals; and the force maintained in their muscles is to the force generated by the product of their labor as 1 to 1,000 at most. This steam labor force is equal to the working force of 25 million horses, the theoretical horse power being about equivalent to the working power of two horses; and relatively to the producing capabilities of the soil, each horse consumes three times as much food as a man. To put steam power, therefore, in the place of 25 million horses is equivalent to a saving of food for about 75 million human beings more than could otherwise be fed from the same area of soil, under the same state of cultivation. Thus the stock of products of the soil which remains for division among human producers is enormously increased.

Now, we may consider the immense variety of work done by this steam power, and we may add to it the labor of water power, which consumes even less than steam of the earth's products. These vast forces enable man to do from five to a thousand times the quantity of work that he could with his unaided hands. Again, the improvements in mechanical devices yield a colossal gain of product from a given quantity of human labor employed as auxiliary to machines. Take the power looms, three of which machines, making cotton goods and attended by one man, can produce daily 78 pieces of fabric, 29 yards long and 25 inches wide; whereas on the old hand loom of 1800 one man working one loom produced only 4 pieces. In the spinning or weaving of woolen and fine fabrics, the production is multiplied fully tenfold; the sewing machine has produced like results in the manufacture of garments, and thus one of the primary wants of man, his clothing, is gratified by one tenth the human labor required half a century ago. In the matter of shelter, house building, modern woodworking machinery has revolutionized the carpenter's trade. A planing machine does the work of twenty men. In agricultural labor McCormick's reaper alone doubled the grain production in the Western States, simply by enabling the available labor of those regions to harvest the crop which the land was capable of producing. Taking into consideration all the gain in productiveness of the last century, it appears that the labor employed in Europe and America is now producing at least six times as much as the same number of laborers could have produced a hundred years ago: or to state the fact differently, only one man need work now where six worked a hundred years ago to produce the same supply for the satisfaction of human wants to the same extent.

SPIRITUALISTS' FACTS AND REAL FACTS.

We have received a polite request to reprint two brief extracts from our issue of September 2. The first, from the editorial "Is Anybody Sane?" runs in this wise:

"Men smitten with the disease cease to be amenable to reason in all matters connected with spiritualistic delusions. The most patent and ridiculous of frauds and follies, reputedly involving spirits and their mediums, are accepted by them with religious enthusiasm."

The second extract is from the letter of a correspondent, and carries, we are told, an emphatic censure of the foregoing, a censure requiring the most liberal use of italics and capitals to do it justice. We give it without such typographical assistance. Here it is:

"It (the law of gravitation) has been attacked in some quarters even by persons of education, and doubts have been thrown upon its teachings. This was done by the great German poet and philosopher, Goethe, among others; but he was simply ignorant of the facts. Every man judges about things according to the amount of information in his possession; and if Goethe had been informed of the manifold facts verifying this theory, he would surely never have attacked it."

If nothing had been said about censure, we should have

taken this communication as a kindly apology for the spiritualists, as people who mean well but are ignorant of the overwhelming evidence against the genuineness of reputed spiritual manifestations and the reasonableness of their theories of spirit existence and action. But censure implies at least a suspicion of error or wrong-doing; and we can see no call for it, nor any indication of it, in the present case, unless our correspondent wishes to insinuate that, as some well meaning people disputed the law of gravitation through ignorance, so we have been condemning, through ignorance of spiritual things, a theory as well supported by verified fact as the law of gravitation is.

If such is the case, we beg to assure him that we have taken pains to enquire into a good many cases of alleged spiritual manifestation of the objective sort, and have failed to discover anything to justify the spiritual hypothesis. On the contrary, every case which has been subjected to real scrutiny has been demonstrated to be a more or less clever fraud, abetted by a positive delusion on the part of the receivers of it; and the probability is overwhelming that the untested cases—if there are any—are of like character.

This is especially the case with objective manifestations. The subjective manifestations, and they are probably the more numerous, are less easy to dispose of, since there is nothing real to bring to light. These involve neither physics nor fraud, but disease. The actors are honest—but insane. Taken in time, a few doses of strychnin and iron, or other nerve tonics, will remove the symptoms promptly and completely. Allowed to become chronic, the disease may, and generally does, run the regular course of ideational insanity.

The unhappy naval apothecary who committed suicide at a pleasure resort the other day—or, as he thought, followed his adored Pauline to the spirit world—is a case in point. The spirit of Pauline which beckoned him onward was as real to him as his own existence; and he could not resist her entreaties to leap the gulf. No reason could convince him that the vision was not his wife's spirit: no, not even the circumstance that his beloved wife was still in the body. Precisely as trustworthy, precisely as convincing to the sane mind, is the testimony of anyone else to the existence of the spirit forms he sees and converses with. It is all craze, where it is not fraud.

A pretty example of fraudulent manifestation is the one exposed in the person of Mrs. Hull in Portland, Maine, the other day. This lady, whose character forbade suspicion, was astonishing believers and unbelievers alike with spirit materializations, under circumstances in which collusion or deceit seemed impossible. In any room in any house, she would stretch a curtain across a corner, retire within the three-cornered enclosure, and, in a little while, "spirits" would come out from behind the curtain, move about the dimly lighted room, speak to the awe-stricken witnesses, and otherwise conduct themselves (one by one) like standard ghosts of good breeding. All this time the medium was supposed to be entranced within her little enclosure: and to make sure that she did not stir, her dress was exposed under the curtain, sometimes drawn out several inches and tacked to the floor.

The spirits triumphed for months, to the great strengthening of such as were in the faith and the serious confusion of the doubtful. But exposure came at last—as it always does, sooner or later. An unbelieving doctor won the medium's confidence, and betrayed it before a number of the ungodly assembled for the purpose of bearing testimony to the medium's discomfiture. By tender entreaties he induced the visiting spirit to trust her hand in his, then held it till lights were struck, and Mrs. Hull stood an unwilling prisoner, a convicted fraud. A little pile of garments in the corner betrayed her method. By sheer audacity she had deceived the very elect with the most honest-seeming materializations that have been exhibited thus far.

"But suppose Mrs. Hull was a fraud, like Katie King and others," our correspondent will probably reply: "that is no proof that spirit appearances are all fraudulent."

True enough: but the unexposed are relatively so few that the presumption—the drift of positive evidence—is decidedly against them. And the circumstance that in every instance the exposure of fraudulent mediums has been made by unbelievers shows the utter incompetency of believers to distinguish deceptive mediums from the genuine, if such there be: in other words, their testimony, however trustworthy in other regions of observation and experience, is good for nothing in this. As we have said before, they are the victims of delusion and mentally incompetent of sound judgment in matters involving their delusion.

Of course we do not imagine that our correspondent, or any like him, will be at all affected—otherwise than displeased—by what we have said. The most courteous reply they can make is that it is our craze, delusion, or what not, to be unable to appreciate the "facts" verifying the spiritualistic theory. We confess the failure: and until we are able first to verify the "facts" (or at least to find out one spiritualistic fact verifiable as neither fraudulent nor foolish) we shall not feel like subscribing to the theory, or even like discussing its probability.

And just here is where we differ from those who disputed the theory of gravitation. They disputed, or wilfully remained in ignorance of, an enormous mass of evidence verifiable by instrumental and mathematical means, evidence that could be verified every time by believers, unbelievers, and the indifferent, alike: evidence, too, which no other theory so easily, simply, and completely satisfied. We, on the contrary, refuse to accept the spiritualist's interpretation of a mass of facts, so called, the most of which have been proved fraudulent or delusive, over and over again; while

for the small residue of fact which may be verified, the spiritualist's hypothesis is inadequate, inconsistent with the rest of our knowledge, and enormously difficult of comprehension.

NEW CHEMICAL TEST FOR ALCOHOL.

Professor E. W. Davy, of Ireland, is the author of a new and very delicate chemical test for alcohol, which promises to be of much practical utility. The substance he uses is a solution of molybdic acid in strong sulphuric acid. When alcohol is brought into contact with this solution, a deep azure blue color is quickly developed. The test is so delicate that the presence of alcohol, in so small a quantity as the one thousand six hundred and sixty-sixth part of a grain in a drop of distilled water, is at once revealed.

The new test will be useful in detecting frauds in the preparation of various medical and chemical substances. For example, pure chloroform, owing to its high price, presents a temptation to fraud, and is often adulterated with cheap alcohol. The consequences, to the sick, are apt to be deplorable, sometimes fatal. By the new test, if there is so small a quantity as one part of alcohol in one thousand, in the chloroform, the presence of the alcohol is at once made known. Professor Davy's interesting paper is given in full in our SCIENTIFIC AMERICAN SUPPLEMENT, No. 46, and will be studied with interest by chemists and druggists.

PETROLEUM CHANGED INTO ELECTRICITY AND LIGHT.

Professor W. A. Anthony, in the course of a recent series of experiments with an electro-magnetic machine of the Gramme pattern, made the following interesting observations:

The electric machine was driven by a five horse Brayton petroleum oil engine (illustrated in SCIENTIFIC AMERICAN, page 303, volume XXXIV). The engine consumed a little over six and a half lbs. of crude petroleum per hour. The lamp used in the engine, by which the explosive mixture is fired, had a one inch flat wick, and consumed 20.8 grammes (459 grains) of oil per hour. The power resulting from the motion of the engine, when applied to the electric machine, produced a stream of electricity or electric light, having an illuminating power equal to that of 234 of the lamps mentioned, showing that three times more light may be produced from a given quantity of oil, if its energy is converted first into mechanical power and then into electricity, than if the oil is directly burned in a lamp.

THE MEETING OF THE NATIONAL ACADEMY OF SCIENCES.

The fall session of the National Academy of Sciences opened in Philadelphia on October 17, under the presidency of Professor Joseph Henry. Professors Joel Allen of Cambridge, George F. Barker and W. H. Gable of Philadelphia, and E. S. Morse of Salem, and General John Newton, were elected members. Professor J. E. Hilgard read an essay on the variations in the standard bars to which all measures are now referred in France, England, and this country. He had compared the iron bars sent to the United States as duplicates of the English bronze bar, and found a variation of 0.00034 inch, which is not an admissible error. Professor Hilgard believes that the bronze and not the iron has changed, and that the alteration is due to one of the metals in the alloy being in a state of tension when the standard was made. In making the platinum standard meter in Paris recently, the metal was remelted and worked over nearly 200 times. The duplicate standards, made of cast steel, for this country, are correct to the $\frac{1}{100,000}$ th of an inch, and differ from each other by less than $\frac{1}{100,000}$ th of an inch.

Dr. J. L. Leconte read a paper on the hydrocephalus, an insect which resembles a fat mole cricket, and of which there is a specimen in the Brazilian Centennial exhibit. He considered that a careful study of existing insect life will do more to demonstrate its course of development than all that can be accomplished by means of fossils, owing to the fact that insects have kept such forms as they have now, with comparatively slight change, during many ages. The hydrocephalus is especially of service as a missing link between such relations.

The Fire on the Hearth.

The Centennial Commission has awarded a diploma and medal to the stoves exhibited by the Open Stove Ventilating Company, whose invention we illustrated on page 198, volume XXXI. Several are shown in the stove annex of the Main Building, the operation being made visible by the outer jacket being removed from one of them, and the circulation of heat and the delivery of the products of combustion in an almost cold state being clearly demonstrated.

To Dispose of Curculios.

A correspondent of the *Ohio Farmer* states that he kept a plum tree from curculios by sprinkling the ground under the tree with corn meal. This induced the chickens to scratch and search. The meal was strewn every morning, from the time the trees blossomed until the fruit was large enough to be out of danger. The consequence was that the fowls picked up the curculios with the meal, and the tree, being saved from the presence of the insects, was wonderfully fruitful.

An English inventor proposes to pump exhaust steam back into the boiler in place of condensing it, and experiments are now being conducted with an engine for testing the invention. The inventor contends that "the pressure exerted by the steam on one side of the piston represents, by its elastic power, the same expressions of power in pressure on the other side; so that the elastic charge is always ready to give back the exact power expended for its expression."

A NEW WATER ENGINE.

We illustrate herewith a novel water engine, which may be used as a motor and also, if desired, as a pump. A is the cylinder, which is mounted in bearings of a case, D, on trunnions. It has a circular valve, E, formed on the lower end, with one port, F, and fitted to the correspondingly shaped valve seat, G, in which is the inlet, H, and the exhaust, I, also the exhaust, J, for the waste from the interior of the case, D. K represents passages cored out in the cylinder, from the upper end down to the interior of the waste water case, to conduct any water leaking past the piston, L, into the case, to be discharged through the exhaust. A cap, M, screws on to the top of the cylinder, for a guide to the piston rod, N, and these passages, K, enter the cylinder, above the piston, under this cover. The oscillation of the cylinder in the case alternately opens the supply and exhaust passages.

Patented through the Scientific American Patent Agency, September 5, 1876, by Mr. George Wells, Montreal, Canada.

A Machine for Making Cab Drivers Honest.

The latest invention for securing "machine honesty" is the exceedingly ingenious registering device which is to be placed on the new line of street cabs shortly to be established in New York city. It is the invention of Mr. Louis Von Horen, late of Vienna, Austria, and it serves the dual purpose of preventing the cabman pocketing any share of the fares and also of indicating to the passenger the length of time he occupies the cab, so that there is no room for dispute as to how much the latter should pay. The charge is to be at the uniform rate of 50 cents per hour or the same sum for a single trip occupying less time; and the apparatus is of course adjusted with reference to this tariff.

There is a metal circular case about eight inches in diameter, on the face of which are two graduated circles. The inner circle is pointed off similarly to a clock face, only instead of a twelve hour mark there is a zero. On the outside circle there is a simple graduation of units and tenths, so that dollars and cents by it may be registered. The hands on the inner circle are controlled by clock mechanism in the case; the hand on the outer circle must be moved by the driver. From one side of the clock case extend wire rods which carry a sign on which are the words "to hire;" on the same side, and between the rods, there is an extension in which a watch is placed. The whole is pivoted to the front of the cab, just in rear of the driver's seat, in such a manner that, when the "to hire" sign is turned uppermost, it stands above the cab roof, and is plainly visible. Right in face of the passenger in the cab, there is an opening, empty when the sign is turned up as described, but allowing the watch face to be seen through it when the sign is turned down.

Now, when a cab is hired, the driver is obliged to turn his sign down. If he does not, the passenger will demand it, because otherwise the passenger cannot see the watch which is to be consulted in determining the time he has occupied the cab. The driver, in turning the apparatus, thereby sets the clock going, which, supposing the trip to be the first one made that day, registers hours and minutes from 0 o'clock. When the passenger leaves the vehicle he pays his fare, and this the driver registers after the bell punch fashion on the outer dial already described. The driver then must turn his sign up. If he does not, his clock will continue running, and he will have to account for the time in money. The next passenger is registered in the same way—the clock, however, starting at the point at which it left off before—so that at the end of the day, when the inspector comes around, he sees from the two dials, first, the number of hours the cab has been used, and second, the amount received. On the back of the clock, which, on its face, has these dials, is still another dial visible from within the cab. This is simply an index moved forward one degree each time the sign is turned, so that from this the aggregate number of trips made can be learned. The dial is covered and locked up so that the driver has no access to it; and it obviously prevents the driver from taking advantage of the short trips, less than an hour in duration, but charged for as a full hour. By noting the number of trips and of hours employed, the inspector can determine the exact sum due from the driver, which amount ought to be accurately shown on the face of the register.

The device, while somewhat difficult to describe intelligibly, is really very simple, and as an invention it certainly is the best thing of the kind we have ever seen. It neither incommodes passengers as do turnstiles, nor does it fasten a disagreeable badge on the conductor or driver like the bell punch, nor does it place such implicit reliance on the honesty of the average passenger as is involved in the use of the fare box now in use in all our omnibuses.

How to Settle a Dispute.

The Centennial Judges and Commissioners catch severe scoldings from exhibitors who have received no awards, and from those who do not monopolize all of the praise bestowed on classes of articles. The former think the medals and certificates of no value, on the sour grapes principle; the latter regard them as too cheap and commonly distributed to be worth much. There is only one way to test the soundness of these depreciatory opinions. The Commissioners do not publish the language of the decisions. Perhaps, in justice to the contributors, they ought to do this,

and acquaint the whole world with the official result of the competition. As this is not done by the Commissioners at the expense of the Fair, the winners of the prizes have no option but to do it for themselves. Let the unprejudiced public be the arbiter in these disputes about the practical worth of the awards. The test is easily made. A reasonable amount of advertising in the papers would tell everybody what the judges said of any particular article and where it can be found. People would then hunt it up and see for themselves whether it tallies with the judges' descriptions or not; and at the same time the successful exhibitor would learn from this *experimentum crucis* exactly what the award is worth to him. There is no other possible

The disk, *f*, prevents the stopcock from being turned more than enough to open and close it by engaging with the pin, *g*. The pipe, *i*, for street washing, is provided with a nipple, *G*, formed on the plate, *D*, and provided with a cap, *h*, and to which the hose is attached for street washing. When the street washer is not required, the pipe, *i*, nipple, *G*, and accompanying devices may be dispensed with, and the pipe, *B*, may run horizontally into the house. When this improvement is used, it is claimed that heaving by frost is obviated. It is impossible for it to become clogged, as there is no channel by which anything can find its way into the lower parts of the device. It is not easily tampered with, as it is impossible to remove the caps without the key or wrench.

How Loggers Live.

Three hundred men will cover and cut a section of about three miles square, taking off over 60,000 logs, which would measure about 10,000,000 feet, each season. Work begins at daylight and ends at dark; and when the days lengthen or the moon favors a longer twilight or earlier morn, the men get the benefit in longer working hours. On the river when the drive is started, work begins at three o'clock in the morning and ends at nine in the evening, the men having five meals; breakfast at six, lunch at nine, dinner at twelve, supper at five, and tea at nine. The meals consist of pork and beans, corn bread, molasses cake, and tea or coffee.

No stint is given to a man's appetite. The fare, such as it is, is abundant, monotonous, nutritious, and cheap. A cook is provided for every fifty men. The beans are generally the large white bush, parboiled in pots holding half a bushel, then ten pounds of pork is set in the middle of the beans in the pot, a quarter of a pint of molasses poured in, and then the pot is set in a hole surrounded with hot ashes and burning charcoal, the top covered with a stone, over which a heavy wood fire is built; and here they stay from five to eight hours, coming out a most palatable dish. All the baking is done in rudely built stone ovens, which are heated, before the dough is mixed, with a good wood fire. The loaves of biscuit or cake are set upon the hot stones, and are cooked quickly and thoroughly.

A camp of three hundred men will consume daily four barrels of beans, one half a barrel of pork, one barrel of flour, half a barrel of meal, one quarter of a barrel of sugar, and five gallons of molasses. The men are encamped in tents, making their beds of boughs, while their extra clothing, a pair of duck overalls, woolen shirt, and two pairs of woolen socks, is kept in an old grain sack and used as a pillow at night.

The Sabbath in the woods is always a day for sharpening axes, mending sleds, repairing boots and clothes, setting out a new tenting spot handier to the cutting in the woods, and all the odd chores which would grow out of the congregation of so large a body of men. All well regulated camps exclude liquor. The work being usually fifty to two hundred miles from any settlement, and the men not being paid until the end of the season, there is little inducement for any speculator to peddle rum through the woods, or for the men to straggle off in search of it.

The consumption of axes and handles is enormous, an ax lasting a month, and a handle about three weeks. The axes are sharpened daily, some camps having regular sharpeners, while others require each man to keep his own axe in order. The old axes are never collected for the junk dealer, the distance to ship them being almost too great to make it an economical measure. Woodsmen generally consider spruce harder on axes than either birch or pine. The gum which runs out of the spruce tree is often found hard enough to chip the edge of the axe when striking through it. The styles of axes differ with nationalities, a Canadian chopper preferring a broad square blade with the weight more in the blade than elsewhere, the handles being short and thick. A down-east logger, one from Maine, selects a long, narrow head, the blade in crescent shape, the heaviest part in the top of the head above the eye. New York cutters select a broad, crescent-shaped blade, the whole head rather short, and the weight balanced evenly above and below the eye, that is, where the handle goes through. A western backwoodsman selects a long blade, the corners only rounded off, and the eye holding the weight of the axe. The American chopper, as a rule, selects a long straight handle. The difference in handling is that a down-easter takes hold, with both hands, of the extreme end, and throws his blows easily and gracefully, with a long sweep, over the left shoulder. A Canuck chops from directly over his head, with the right hand well down on the handle to serve in jerking the blade out of the stick. A Westerner catches hold at the end of his handle, the hands about three inches apart, and delivers his blows rather direct from over the left shoulder.

In fact, an expert in the woods can tell the nationality or State a man has been reared in by seeing him hit one blow with an ax. It is, however, an interesting fact to know that a Yankee chopper, with his favorite ax and swinging cut, can, bodily strength being equal, do a fifth more work in the same time than any other cutter, and be far less fatigued. This in a very large degree will account for the greater percentage of Maine men who will be found each year in the woods of northern New England and New York. *Northwestern Lumberman.*

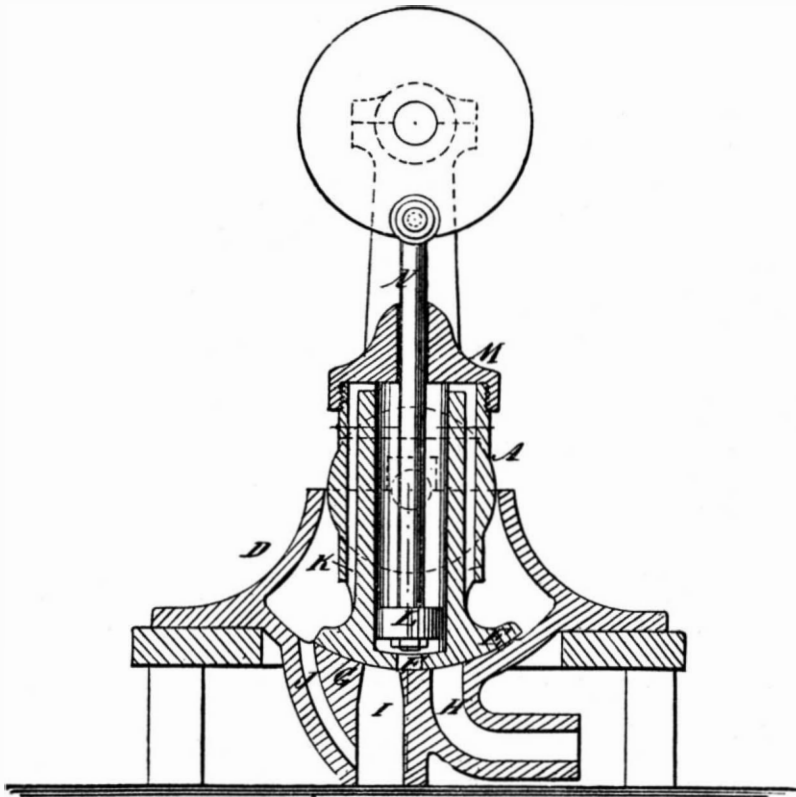
**WELLS' WATER ENGINE.**

settlement of the controversy, but by advertising. We still adhere to the opinion that the prize system adopted by the Fair managers is the best under all the circumstances; and the recipients of the certificates have it in their power, by judiciously advertising, to turn them into money.—*Journal of Commerce.*

IMPROVED STOPCOCK AND STREET WASHER BOX.

Mr. George B. Hooton, of Williamsburgh, N.Y., has patented through the Scientific American Patent Agency, September 5, 1876, a novel improvement in stopcocks and street washer boxes. It consists of a box, of cast iron, provided with slots, *a*, in opposite sides, to receive the water pipe, *B*. These slots are closed by the doors, *b*, which are pivoted and

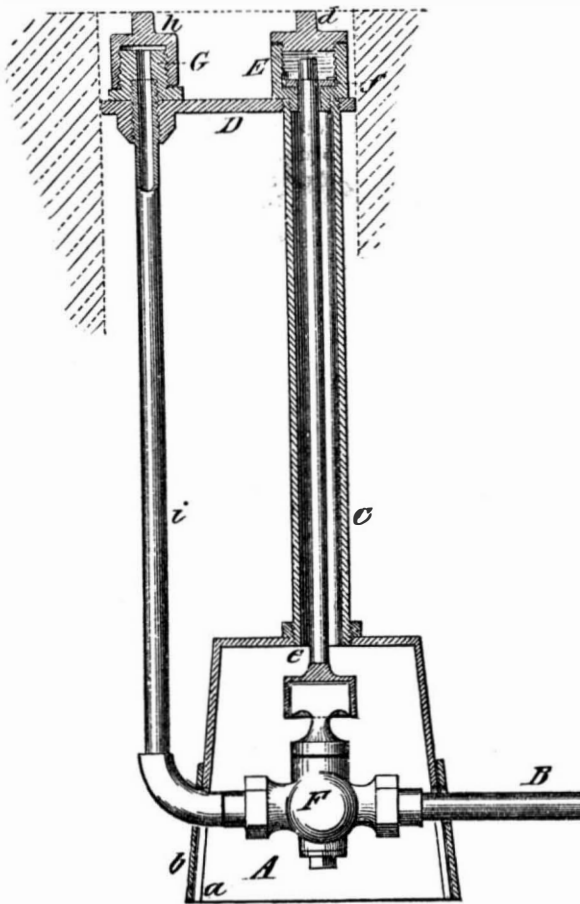

notched to receive the pipe. C is a tube of suitable length, screwed into the center of the top of the box, A, and also screwed into the plate or guard, D. E is a socket formed on the upper surface of the plate, D, and provided with the screw cap, d. F is a stopcock in the box, A, the plug of which is provided with an elongated stem, e, which runs upward through a hole in the plate, D, and is squared to receive a notched disk, f, and the key by which it is turned

NEW SCREW-CUTTING LATHE.

We extract from the *Moniteur Industriel Belge* the annexed engraving of a screw-cutting lathe, the novel feature in which is the system of friction gearing by which the screw to be cut is made to advance or return. Above a toothed wheel, upon the driving shaft, are placed two pinions, both gearing with the former wheel, and consequently revolving in opposite directions. At the extremity of the pinion shafts are friction pulleys, which bear against the interior of the rim of the large friction disk. By means of a hand lever, either of these friction pulleys may be brought into contact with the disk at will, and the latter thus caused to rotate in either direction, turning the screw accordingly. The device is intended to be portable, and cheap. It is the invention of MM. Weise and Monski, of Halle, Germany.

Red Wash for Brick Residences.

Travelers visiting Chicago are astonished at the beautiful appearance of the brick buildings in that city, showing so distinctly the lines of white mortar between the bricks. It has taken years of trial, says the *Enquirer*, before a mixture could be found that would stand the test of rain and frost. At last the following has given thorough satisfaction: Venetian red and Paris brown, in proportion to suit the taste, are mixed with a quantity of water to make a heavy wash. With this the walls are well coated. To settle the color to the wall, and prevent its washing off by the rain, a wash with diluted muriatic acid (one quarter acid) is given over the painted surface.

The mixture forming the white lines or joints is made of settled white lime, to which is slowly added plaster of Paris, kept stirring until the mixture is past setting; then mix a little fine sand, to keep from cracking, and work into the consistence of glazier's putty. This putty is then applied to the walls by two men, along a straight edge, and with a beading trowel, the distance of the joints having previously been measured. Care should be taken, in applying this putty, to press it strongly against the wall, to prevent any water from creeping between it and the brick. In winter time we should suppose that the water would freeze, expand, and detach the white joint, thus spoiling the look of the building. But it is important if the treatment above described proves effectual. It is certainly worth trying, for an indestructible red and white paint on brickwork is very beautiful.

England's Dilemma.

The rapid stride of Americans in manufactures connected with iron and steel is impressing upon English makers the necessity of accommodating themselves to the demands of the time, to avoid the almost total destruction of the export trade, and to insure the continuation of the home production. Recent publications upon the subject exhibit upon the part of English makers a spirit of earnest inquiry into the cause of their present condition, and a determination to recover if possible the ground already lost. Among the most earnest of these publications are a number of recent editorials in the *London Times*, containing careful reviews of the situation, which is acknowledged to be serious, and the British people are urged not to "resign themselves to a permanent exclusion from the markets in which the United States manufactures compete—and to estimate more justly the conditions on which business should be conducted in future." It is not admitted that the protection afforded by almost prohibitory tariffs has had any material effect in contributing to the success of American makers; but the conclusion is reached that this result is mainly attributable to the reduction of the cost of manufacture in the United States by the use of machinery, mainly devised with the view of dispensing with the hand labor, but incidentally resulting in supplying better products. While English manufacturers have, admittedly, been pursuing old and wasteful methods, encouraged until lately by the low prices of fuel and labor, and have rested secure in the apparent monopoly which has so long existed, the manufacturers of the United States have been forced by the high price of labor to devise and employ appliances for dispensing with or reducing hand labor to as great a degree as possible. It is the success of these efforts that has resulted in almost totally destroying the markets heretofore enjoyed by the English manufacturers in the United States and in greatly impairing their trade in the British colonies, and, in some instances, even in England. As a remedy for this condition of affairs, English manufacturers are placing their workshops upon a better footing than heretofore, by the adoption and use of new labor-saving processes and machinery, and are already congratula-

ting themselves upon the advance made in this direction. With this view a recent meeting of the Institution of Mechanical Engineers, at Birmingham, devoted a large portion of its time to the consideration of modes and appliances for dispensing with hand labor in puddling, it being admitted that this result was indispensable to the obtaining of products of the quantity and at the prices now required to meet the demands of the market. So, also, earnest efforts are made to remedy the evil by reducing the cost of labor. When our British cousins take hold in earnest with the intention of overcoming obstacles to their progress, we may be

3, and 1½ inches for Fig. 4; and the grooves being on the under side, this allows a wearing thickness of about ¼ of an inch, or double that of ordinary flooring. The size of the sections average 18 or 24 inches square.

Patented through the Scientific American Patent Agency, May 30, 1876. The patent was reissued on August 29, 1876. The invention was also patented in Great Britain on June 14, 1876, and in Canada on June 30, 1876. For further particulars, address the National Wood Manufacturing Company, as above.

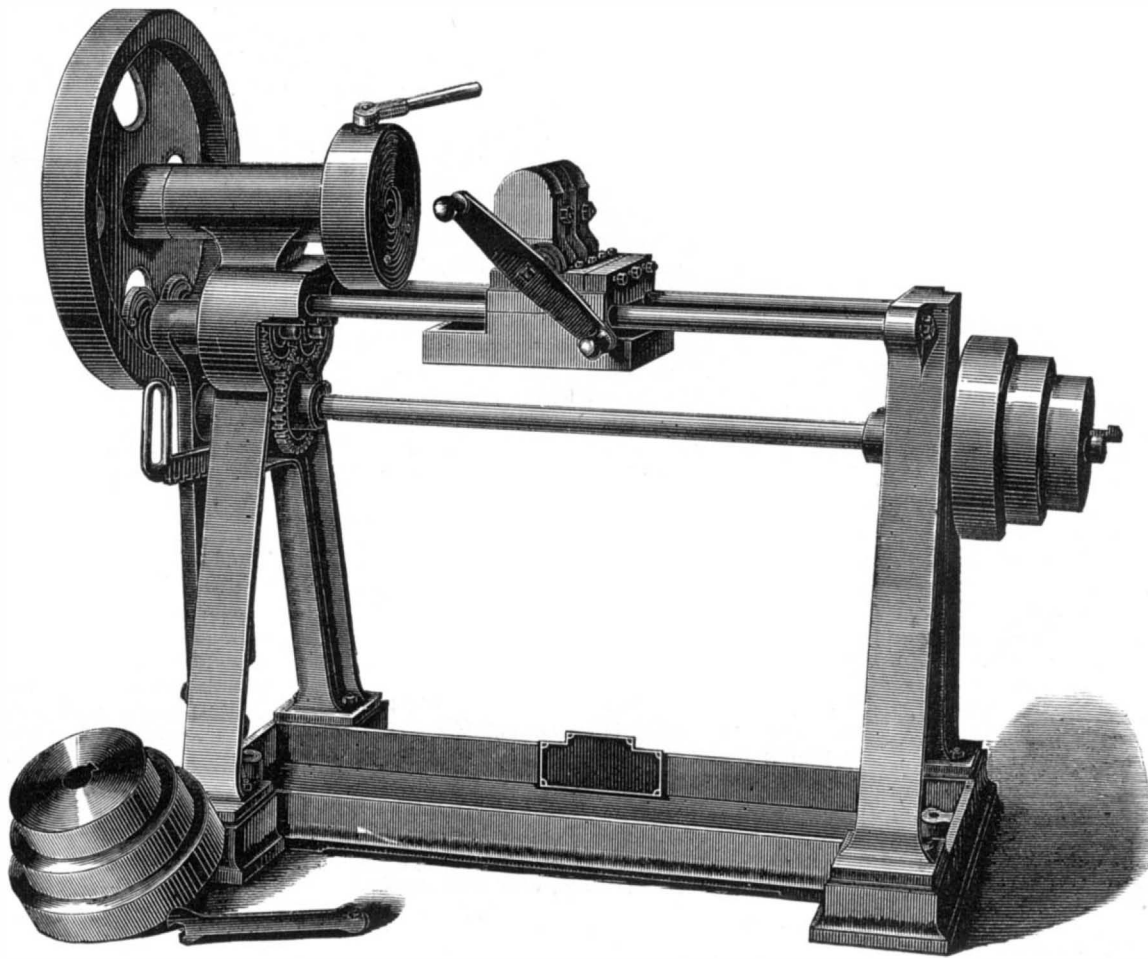

WEISE AND MONSKI'S SCREW-CUTTING LATHE.

sure that such obstacles will be conquered if possible, and American manufacturers may well bear in mind the experience which resulted so disastrously to their rivals, and avoid falling into a like error. There must be no suspension of efforts to perfect and improve, with the idea of having reached a secure point. Those who are in advance must go forward, or they will soon be in the rear.—*American Exchange and Review.*

IMPROVED WOOD CARPETING AND INLAID FLOORS.

The National Wood Manufacturing Company, of 950 Broadway, New York city, for several years engaged in the manufacture of wood carpeting and inlaid floors, have devised a new method of constructing tessellated flooring for private or public buildings, which is illustrated herewith.

Fig. 1 shows a sectional block or square, composed of pieces of wood of various forms, sizes, and colors, combined in one section. By the aid of suitable machinery, a series of dovetailed grooves are cut in the under side of each floor block; and dovetailed strips of wood, or binders of other suitable material, are inserted in these grooves, as shown in the side view, Fig. 3, and held in place by glue or waterproof cement. The blocks are then brought to an even surface and size, and are ready for laying in the usual manner. Fig.

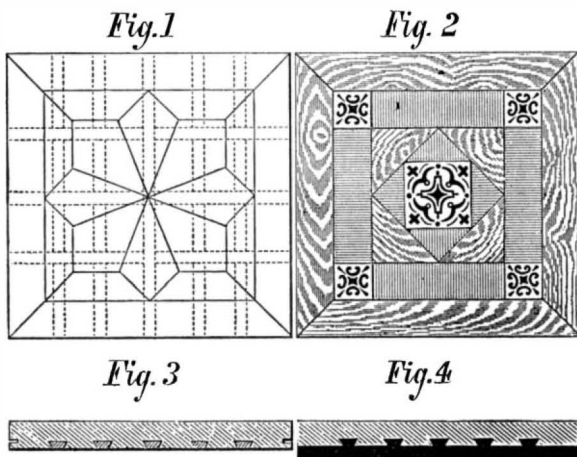

4 shows a modification of this method of construction, a preparation of asphaltum being used, which firmly adheres to the wood, fills the grooves, and forms a solid and substantial backing for each section.

Fig. 2 shows the use of ornamental tiles in combination with the wood, as they are retained in place by the adhesion of the asphaltum. The tessellated flooring is especially adapted to buildings of fireproof construction, and wherever else it is requisite that a strong, durable, perfectly waterproof, and airtight floor should be used. It may be secured to the floor by first spreading a thin layer of hot asphaltum on the floor, and then pressing the sections down upon the floor. The average thickness of the flooring is ¼ of an inch for Fig.

the middle of the day, in bright weather, the climbers will possibly do little harm, and to plants in flower they may even be an advantage by breaking the force of the sun's rays; but for every hour they are of benefit to plants underneath them, there occur a dozen in which they do serious injury, and that in proportion to the extent to which they obstruct the light. If amateurs use them in houses of the description under consideration, they should employ only the most spare growers, such as will furnish but a moderate number of pendent shoots, avoiding all strong rampant-growing kinds; for although it is easy to keep the latter within bounds by a free use of the knife, yet this work does not always receive attention, or there is a reluctance to cut away the shoots.

The more light the house affords, from the principle upon which it is constructed, and the favorable position in which it stands, the more roof climbers may be allowed. During bright sunny weather in the summer months, most flowering plants will last longer in bloom if they are shaded in the middle of the day; but nothing is more common than to see this so much overdone that the whole are seriously injured by the obstruction of light through the material employed being too thick, or the use of fixed shading. Where either of these evils exists, it is impossible for the plants to remain long in a satisfactory state. It should always be borne in mind that almost every plant which we cultivate under glass receives in its native country considerably more light than our climate affords; therefore, wherever blinds are used, they should in all cases be attached to rollers, so as to be easily drawn up and down as occasion requires, and they should never be allowed to remain down when the sun does not shine upon the house. Even in the case of ferns (with the exception of the filmy species and a few that exist naturally in shady situations), they thrive much better fully exposed to light when the sun is not upon them.

Training Canaries.

A gentleman residing at Phoenixville, says the *Reading Eagle*, of Queensland, Australia, has several very fine canary birds to which he has given much attention. One of the birds he has taught to sing "Home, Sweet Home," clearly and distinctly. His mode of instruction is as follows: He placed the canary in a room where it could not hear the singing of other birds, and suspended its cage from the ceiling, so that the bird could see its reflection in a mirror. Beneath the glass he placed a musical box that was regulated to play no other tune but "Home, Sweet Home." Hearing no sounds but this, and believing the music proceeded from the bird he saw in the mirror, the young canary soon began to catch the notes, and finally accomplished what its owner had been laboring to attain, that of singing the song perfectly. This is an experiment easily tried, and one we should be glad to know the result of from some of our own bird fanciers if they make the experiment.

Continued from first page.

wherever the visitor may wander, except, perhaps, in the Woman's Building and the Art edifices, boats meet him at every turn. Had this magnificent display been brought together and classified, it would undoubtedly be the largest and most instructive ever gathered. Certainly, any one desiring to prepare an exhaustive work on the subject might find at the Centennial all the material necessary for the task.

The engravings which occupy our first page this week represent a number of the most curious and widely differing vessels, selected from the displays of the different nations. Standing in the middle aisle of the United States Building is the gigantic dug-out—an immense canoe hollowed from the trunks of massive trees—by the Vancouver's Island Indians, and measuring 60 feet in length by 8 feet beam. It is made in four pieces, and was probably intended for warlike purposes. In the engraving, the painted bow is represented, covered with the strange picture writing peculiar to its savage builders. The designs, notably of the eyes, depicted near the bow, curiously correspond with the similar decorations to be found on Chinese junks. This is a slender link, but is perhaps of some ethnological value in indicating the relationship between the tribes, part of which went to the southward in Asia, and part crossed Behring's Straits, and entered the American Continent. The British Columbian whaling canoe, shown above the dug-out, reminds one somewhat of a Venetian gondola. It is made in few pieces, and has a broad gunwale ending in a fork at the bow. The same strange Indian designs are painted both inside and outside the vessel.

Not very long ago, the yacht Amaryllis, built on the catamaran principle, vanquished several of the finest center board and keel yachts in this vicinity. This circumstance has directed interest to this peculiar mode of construction; and we represent three of these odd boats, as made in as many widely separated parts of the globe. The simplest is the catamaran of the Philippine Islands, which is merely an ordinary canoe having two bent spars lashed athwart ships and connected by rough cross logs at their extremities. These prevent the boat capsizing, through resisting her tendency, when she heels, to submerge them. The anchor used by the Philippine Islanders is likewise represented. It consists of an iron-tipped hook of wood, and is obviously of little value, since there is no way for it to hold bottom unless the hook end falls underneath.

The second catamaran, that peculiar to Pernambuco, Brazil, is of an entirely different species, and is not a true type of its kind. The name catamaranis, however, applied in the navy to an assemblage of empty casks, lashed together and covered with a staging to form a raft; and in some parts of the world any raft of logs obtains a similar title. The present craft is, however, peculiar, because it has a center board, an odd appliance for a raft. The cabin, which is just big enough for the occupant to crawl into head first, is mounted on a slanting platform, and there is a huge steering oar held in a high crotch. The sail is odd shaped, and, being widest at the top, is excellently adapted to capsize any vessel on which it may be placed; hence probably the reason for the center board. Catamaran No. 3, from the Sandwich Islands, is an elaborate affair, but genuine in its way, inasmuch as it embodies the principle of "united we stand, divided we fall," as all true catamarans should. The main canoe is so very high and narrow that it would promptly upset, even without the aid of its immense mast and sail; but the broad outrigger and solid boat-shaped block at the end thereof hold up the whole fabric. These vessels sail faster than any known sailing craft, and are staunch in the roughest seas. The Hawaiian catamaran is a double-ender, that is, it sails either bow or stern first. It never tacks to turn around. When the ingenious captain desires to go about, he casts loose the forward lower corner of his sail, hauls it around to the other end of the boat, and makes it fast there. Notice, also, that the mast is stepped on the gunwale and thus brought nearer to the center of gravity of the whole combination.

Another curiously primitive boat is the tub-like affair made by the Gros Ventre Indians, of Dakota Territory. It is a mere basket of ash or hickory withs, covered with raw hide, and propelled by the paddle shown. An odd fact here to be noted is that this craft is almost identically the same as the coracle used on the rivers in Wales for fishing purposes. In fact no one can study all these kinds of boats without becoming impressed with the similarity of working in the minds of people, utterly dissimilar in race and in every other respect, in order to reach a given object. Compare the old Swedish anchor, illustrated side by side with the like device peculiar to the Brazilian aborigines. The same apparatus is employed by our own east coast fishermen. Doubtless hundreds of persons have each deemed themselves the original and only inventor of that contrivance.

There are strange contrasts among the boats. The Philippine catamaran is so long and narrow and high that it must, to sail at all, be held up; on the other hand the Dutch fishing pink is so short and broad and low that it would be difficult to upset it. The craft is very nearly as broad as it is long; the mast is stepped very nearly in the middle of the boat, and there are two bowsprits, although why the ordinary rule, of attaching jib and staysail to one spar, is not followed is a mystery. The pink is built for sailing in very shallow water, such as is found on the shoals in the North Sea; and to prevent her drifting to leeward, crab-fashion, huge weather boards are attached to her sides and dropped vertically into the water to offer a wide area of resistance. These vessels, like everything Dutch, are usually models of neatness, and abound in varnished wood and brilliant brass ornaments, to the exclusion of paint.

Another sharp contrast is found between the Indian skin boat, already described, and the Greenland kayak or "man's canoe." This boat is usually about 16 feet long, 2 feet broad, and 1 foot deep. The bottom is rounded and has no keel. The frame is kept stretched above by a large number of little beams, and two strong battens run from stem to stern, which, toward the middle, are attached to a hoop of bone large enough to admit the body. The frame is entirely covered, with the exception of the circular hole in the center, with freshly dressed seal skin. When complete, the boat weighs about 60 lbs., and is so constructed that it can be carried on the head without the aid of the hands.

The vessels in which the ancient Northmen made their voyages, which resulted in the discovery of America and Iceland, or in which the Danish Vikings sailed on their pillaging expeditions to the coast of England, find their modern reproductions in the Norwegian craft now used for fishing and pleasure purposes. The high prow, whereon was the dragon's head in ancient times, may be traced in both the Nordland's raasells (reefed sail) yacht and the fishing smack which we illustrate. The former has the old square sail, and in model is almost the same as the Vikings' vessels.

The curious Russian double canoe is in the Russian section of Machinery Hall. It is a beautifully made craft, having a hull in two portions and a comfortable arm chair located on a grating between. The Russian single canoe has a neat rig, easily managed by the sole occupant of the vessel. The gaff is fitted with halliards and downhaul, leading through fair leaders to the cockpit. Another type of vessel, which disputes with the canoe the supremacy for pleasure purposes, is the duck boat. Our sketch is taken from the craft in which Mr. N. H. Bishop, of New York, made his famous voyage from Pittsburgh *via* the Ohio and Mississippi rivers to the Gulf of Mexico, and thence to Cedar Keys, Florida, a distance of 2,600 miles. The boat is very wide, and draws but very little water. The screen shown serves as a protection against the weather, and as a tent at night.

The celebrated yacht America, a vessel which won her laurels in 1851, and which our yacht builders, with all their skill, have never yet improved upon, had masts which raked heavily aft, and she drew nearly three times as much water aft as forward. Despite the speed and other advantages thus gained, a shipbuilder in Bombay has constructed the Ocean Queen in diametrically the opposite way, and claims that she beats steamers, making, with a favorable breeze, some 20 knots per hour. The masts rake, Malay style, greatly forward, where the heaviest draft of water is found. It remains for naval architects to reconcile the discrepancy if they can.

The last two vessels which we have to describe are essentially the outcome of Yankee ingenuity. The first is a non-heeling boat. The hull is hung on pivots in a heavy frame, which constitutes stern post, stem post, and keel in one. The mast is stepped in the stern. Consequently, when the wind pushes the sail horizontally, the keel, etc., are alone lifted, while the boat remains perpendicular. The turkey bone yacht, some ingenious New Englander has contrived from the sternum of the turkey. It is needless to say that its size is diminutive, and that it is not intended to sail. A deck is attached to the under part of the bone, the narrow projecting part of which forms the keel. Rudder, bowsprit, mast, and sails, and small boats complete the resemblance to a miniature sloop.

Correspondence.

The Necessity of an Effective Steam Engine Governor.

To the Editor of the Scientific American:

The most important question for our manufacturing interest is how to reduce cost of production without cutting down wages of operatives, now too low in many sections of the country. As manufacturers look to you largely for information and help, permit me to make a suggestion.

The markets of the world are open to American manufacture, provided they can furnish fabric as cheap as any other nation. We can produce goods cheaper, and yet pay a fair price for labor. We have the best machinery, and our operatives are more intelligent and capable than can be found elsewhere. How then shall we produce more goods from the same mills and without material increase of cost? The answer is simple: By increasing the speed of machinery, which cannot produce its most profitable results without being run at the highest rate of speed consistent with its durability and with the production of a perfect fabric.

But no machinery can be run at or near its highest rate when subject to uncontrolled variations. Suppose, for instance, that it is found in a mill that all work can be well done with the main engine running at 55 revolutions. Now, if the engine varies 4 revolutions in its speed, under different loads of work or a varying pressure of steam, it is manifest that it will not be prudent to run the engine at over 52 revolutions, lest mischief be done when the speed increases. If the engine could be held within one revolution, it is clear that it could be run at 55, and practically, with its steady motion, even a little higher than that. This would give a net increase in production of from six to ten per cent. Until recently, this has not been practicable, but it has become so.

Mr. Huntoon, of Massachusetts, a most thorough engineer, who has devoted twenty years of his life to controlling steam engines, has invented a governor which will do this, and which is rapidly coming into use. His governors are now used by the Merrimack Manufacturing Company, the Naumkeag, the Groveland, and hundreds of other mills, and are

in many cases largely increasing their production. This governor is simple in construction, not liable to get out of repair, neat in appearance, noiseless, powerful, and inexpensive.

The unnecessary wear and breakage of machinery and consequent stoppage for repairs, the temporary delays for mending broken threads, and the value of various fabrics injured or spoiled, are all large items in the expense of running a mill, a great part of which is the result of varying speed. The increase in quantity and improved quality of the products of cotton, woolen, iron, flour, and all other mills running at a maximum and even speed, will give a large profit over what can be produced by the same mills running with varying speed. It will give me pleasure to send, to persons interested, full descriptions of this governor.

STILLMAN B. ALLEN.

Boston, Mass.

Large Belts.

To the Editor of the Scientific American:

In your issue of October 7, mention is made of a very large rubber belt, manufactured by the New York Belting and Packing Company, namely, 331 feet long and 4 feet wide, which was considered the largest belt ever made. Messrs. J. B. Hoyt & Co., New York city, have recently made, for Jessup & Moore's paper mill at Wilmington, Del., a double leather belt 186½ feet long and 5 feet wide. It weighs 2,312 lbs., contains 1,865 square feet of single belting, and has taken 150 of the heaviest oak-tanned hides, selected from 5,000. I think this belt is the largest ever made.

New York, October 14, 1876.

S. R. K.

[For the Scientific American.]

CUTTING SPEEDS FOR LATHE WORK.

There is a wide variation in the speed at which different workmen will cut the various metals in the lathe, and it is very difficult for all save the most expert to determine when a tool is or is not performing a maximum of duty. We append below a table of cutting speeds for average work upon metals of the ordinary degree of hardness. Here, however, we may remark that these rates are not intended for use with tools which are so slight in form as to require to be tempered below a very light straw color; and the figures have in fact been determined from the use of tools whose temper has not been drawn at all, for the reason that no turning tool should have its temper drawn unless it is so thin as to be liable to bend from the cut, as in the case of a very slight parting tool. If it should be found in any case that the tool will not stand the rate of cut here given, the fault is most likely in the tool, and should be looked for in the forging or the shape thereof. The fault in forging is apt to be overheating in the fire. If, however, the metal of the work becomes, when the tool is applied to it, bright and glossy-looking, it is hard, especially if the turnings fly off in spurts. If, upon brass work, the tool at the given speed springs into the work, or either jars or chatters, the fault lies in the shape of the tool, and not in the cutting speed; and the remedy to be applied is not to grind the uppermost face of the tool so keenly, which will inevitably remedy the evil. The lathe revolutions are given, instead of the feet of cut per minute, so that the operator can ascertain the ratio of the duty he is performing without requiring to make a calculation. For copper work, the speed may be from two and a half to three times the speed given for brass work.

If hand tools are used, the speed may be in each case increased, especially in the case of scrapers upon cast iron and brass.

WROUGHT IRON WORK.

Diameter of work in inches	Lathe revolutions per minute for roughing cuts	Lathe revolutions per minute for finishing cuts
1	135	145
2	50	60
3	30	35
4	20	23
5	16	18
6	12	14

CAST IRON WORK.

Diameter of work in inches	Lathe revolutions per minute for roughing cuts	Lathe revolutions per minute for finishing cuts
1	145	150
2	70	85
3	45	55
4	30	38
5	23	30
6	16	22

BRASS WORK.

Diameter of work in inches	Lathe revolutions per minute for roughing cuts	Lathe revolutions per minute for finishing cuts
1	450	450
2	194	200
3	100	110
4	66	72
5	45	70
6	37	70

STEEL WORK.

Diameter of work in inches	Lathe revolutions per minute for roughing cuts	Lathe revolutions per minute for finishing cuts
1	75	80
2	35	45
3	30	30
4	15	18
5	12	15
6	9	10

New York city.

J. R.

Raising Nut Trees.

Every true lover of nuts likes to raise trees and test the different varieties. The very best kinds should be selected for cultivation, says a writer in the *American Socialist*; and if the seeds are saved from the most perfect of them, the chances for producing good fruit will be more certain. The best method of keeping nuts for seed is to let them get quite ripe before gathering; then partly dry them and mix in dry sand, put them in thick, mouse-proof boxes, and bury in sand on a dry bank. In spring, select a rich, loamy soil, plow deep, pulverize well, and drill in the nuts, far enough apart to allow the trees some space to grow and room to cultivate between the rows. As soon as the young plants appear, the soil should be loosened around them frequently, which will effectually prevent weeds from growing, as well as hasten the growth of the plants.

After the second year's growth it might be well to clip off the ends of the vigorous side branches, thus sending the life into the main stem. As the stalk grows stouter, the branches may be cut close. However, it is better to leave them on a little too long, than to have slender, top-heavy trees.

Do not transplant until they are large enough to be staked, or until they are three or four years old. The ground, if intended for an orchard, should be subsoiled, and the holes for the young trees dug deep, and fertilized with a little old manure, unless the soil is very rich. The trees may be carefully dug, saving all the roots, and leaving them as long as possible and free from bruises. If a part of the soil can be removed with them, all the better. The roots that chance to get cut by the spade, should be cut clean from the under side, in order that the rootlets may start in the best direction. They must be covered with earth or cloths until they are set out.

In setting, some advise to lean the tree a little to the west, or in the direction of the prevailing winds. The young trees may be set at the same depth as when taken up. The roots should be carefully spread, and fine soil packed tightly around them with the hand, and then filled in with dirt and trodden down firmly. A good stout stake, with a string and cloth fastened tightly around it, finishes the job, and the storms may come. Stir the ground often till dry weather, then spread a thin layer of manure, or a thick coating of chip dirt, old straw, or other litter. These are of great benefit the first year, saving the labor of stirring the soil.

After the first year's growth, in order to make handsome and fruitful trees, it is necessary to use the knife freely. "I prefer training the main shoot as leader, encouraging the branches that start out at nearly right angles, and checking or cutting away those too much inclined upward, as they are apt to split off when laden with fruit or snow. I would cut away all branches not radiating from the center of the tree, as well as all cross branches, leaving them far enough apart to let in light and sunshine, and keeping the tree symmetrical in every direction. This can be done by clipping back those branches which have a tendency to get ahead of the rest; and an abundant crop of nuts may be expected."

Professor Wanklyn's Method of Treating Permanently Hard Waters.

These waters contain the sulphates of lime and magnesia, which have always proved to be the most difficult of removal. Professor Wanklyn has recently proposed to soften waters of this class by first adding bicarbonate of soda and then lime. The bicarbonate of soda first converts the sulphate of lime into bicarbonate of lime, and subsequent addition of lime precipitates the bicarbonate so formed. Sulphate of soda remains in solution in the water.

If hard water must of necessity be employed for scouring with soap, it is advisable to separate the hardening matter, by mixing a sufficient quantity of a hot solution of soap with it, and then causing it to run through a filter bed before use. The insoluble soaps will thus be separated without attaching themselves to the wool or fabric, and they may be collected and treated with hydrochloric acid, to decompose them and separate the fatty acids, which may then be collected and reconverted into soap, by boiling them up with caustic or even carbonate of soda, and the soap thus obtained may be used again, for the same purpose. Water thus treated is well adapted for the scouring of wool and woolen goods.

Organic matter, oxide of iron, and often a considerable proportion of the hardening matter, may be caused to rise to the top, and may then be skimmed off, by dissolving alum in the water in the proportion of about 4 ozs. per 1,000 gallons, and then rising it to near its boiling point.

In preparing waters which contain alkaline or earthy carbonates or bicarbonates, as a bath for either mordanting or dyeing, they should be treated with sufficient sulphuric acid to expel all the carbonate acid, and neutralize any alkali which may have escaped washing out from the scour. The use of bran is frequently serviceable in removing impurities from water in the bath.

The refuse waters from a woolen manufactory contains within themselves the elements of their own purification. At the present time, the practice is to turn these refuse waters into the river courses as they are done with. Sometimes mordant baths are run out; at other times the spent dye baths, and soap, or alkaline fluids. These mingle in the common receptacle, the river, and precipitate each other there, thus producing those black deposits which give to our streams in the woolen districts such an inky and foul appearance. Solutions of all the substances used in our woolen industries have mixed and it is found that they precipitate one another, and leave the supernatant water in a tolerably clear condition. The remedy seems to be, so far as the woolen trade affects the purity of the rivers, to run

all the liquids into one common reservoir, and, after subsidence, to pass, if necessary, the supernatant water through a filter bed into the river. The utilization of the black muddy deposit would, doubtless, speedily follow.

On the Size and Weight of Atoms and Molecules.

When a compound body has been divided and subdivided until it is no longer possible to divide it again without splitting it up into its constituent parts, this extremely small particle of matter is called a molecule. A molecule is defined to be the smallest particle of matter that can exist alone by itself. Physicists have also learned that all molecules are of the same size. This law, as laid down by Avogadro in 1811, and by Ampère in 1814, is that "equal volumes of all substances, when in the state of gas, and under like conditions, contain the same number of molecules." These molecules are each made up of one or more atoms, an atom being the smallest particle of matter that can exist in a compound. The molecules of most elementary bodies are made up of two atoms, a few of four atoms, and a few of one atom. As all molecules are of equal size, it is easy to determine their relative weight, provided only that we can convert the substance into a vapor; for its vapor density, or specific gravity as gas, referred to that of hydrogen as unit, gives us the weight of the atom in terms of the hydrogen unit. Thus it happened that we have long known the relative weight of the atoms of nearly all simple bodies, and the weight of the molecules of many compound substances.

To determine the actual absolute size or weight of an atom or of a molecule was, not long since, considered impossible, but careful physicists have succeeded, using as their foot rule the length of a wave of light, in measuring with an approach to accuracy the size of these infinitesimal objects. Sir William Thomson fixes their size between the $\frac{1}{1000000000}$ and the $\frac{1}{10000000000}$ of an inch, probably the $\frac{1}{1000000000}$ of an inch, or the $\frac{1}{1000000000}$ of a millimeter in diameter; and the weight of a molecule of hydrogen, he places at the fifteen million, million, million, millionth of a milligramme (or 0.0000000000000000000015 milligramme), and the weight of an atom of hydrogen is just half that.

J. Annaheim published a paper in the last number of the proceedings of the German Chemical Society of Berlin, in which he described an experiment for showing the minute sizes of molecules and atoms; but his results permit us to suppose the atom of hydrogen far heavier, and therefore larger, than Sir William Thomson's calculations indicate.

Annaheim's experiment is an interesting one nevertheless, because it appeals to the eye, and as a lecture experiment must prove a striking illustration of the extreme divisibility of matter, without the necessity of the rather tedious course of reasoning and abstruse calculations of Thomson. Annaheim dissolves 0.0007 gramme (=0.0108 grain) of fuchsin ($C_{20}H_{10}N_2HCl$) in alcohol, and dilutes the solution to 61 cubic inches. In every 0.061 cubic inch there is 0.00010801 grain of the dye. If some of this liquid be placed in a burette of 1 centimeter (0.39371 inch) in diameter, it will appear strongly colored if viewed against a white background. If we drop the thirty-fifth part of a cubic centimeter into a small dry test tube, 0.8 centimeter ($\frac{1}{10}$ inch) in diameter, the red color can be recognized with certainty by placing the test tube inclined upon white paper, and observing it parallel with the surface of the paper, a second tube of pure water being placed beside it for comparison. This shows that the naked eye can perceive the 0.00000002 gramme of fuchsin (or 0.0000003 grain). As every drop must contain at least one molecule of the substance (whose molecular weight is 337.5) the absolute weight of an atom of hydrogen is not over 0.0000000005 gramme. Cyanin gives about the same figures for a hydrogen atom.

Proposed Retention of the Main Centennial Building.

It now seems probable that the Main Building at the Centennial Exposition will not be torn down after November 10, but will be allowed to remain for permanent exhibition purposes. A request of this kind from prominent citizens of Philadelphia was recently made to the Fairmount Park Commission, but was refused. A conference committee has, however, since been allowed, and the matter has been so forcibly urged that the Commission, it is believed, will reconsider its determination. The building is excellently suited for the purpose intended, much better so indeed than Machinery Hall, which was at first proposed. It is strong, and will stand for twenty years if provided with a tin roof and otherwise cared for. Several of the foreign governments have expressed their willingness to allow their exhibits to remain, and some foreign exhibitors will even increase their displays. About six hundred thousand dollars are required for the enterprise, half of which, we learn, is already subscribed, and the remainder is easily obtainable. The idea is an excellent one, as a great permanent show in which new devices of all kinds can be expeditiously introduced to the public has long been needed. We trust the plan may meet with every success.

Iron Rust as a Cause of Fire.

The rather old notion that fires may be caused by iron rust is thus defended by a recent English writer: "When oxide of iron is placed in contact with timber excluded from the atmosphere, and aided by a slightly increased temperature, the oxide parts with its oxygen, and is converted into very finely divided particles of metallic iron having such an affinity for oxygen that, when afterwards exposed to the action of the atmosphere from any cause, oxygen is absorbed so rapidly that these particles become suddenly red hot, and, if in sufficient quantity, will produce a temperature far be-

yond the ignition point of dry timber. Wherever iron pipes are employed for the circulation of any heated medium (whether hot water, hot air, or steam), and wherever these pipes are allowed to become rusty, and are also in close contact with timber, it is only necessary to suppose that under these circumstances the finely divided particles of metallic iron become exposed to the action of the atmosphere (and this may occur from the mere expansion or contraction of the pipes) in order to account for many of the fires which periodically take place at the commencement of the winter season."

Artesian Wells as a Source of Power.

The *Chicago Journal of Commerce*, in an article on the utilization of the water pressure developed by artesian wells, for the driving of engines etc., makes the following statements, and invites criticism thereon: 1. It is affirmed that many of the wells bored in Chicago or vicinity are capable of throwing a jet of water to a minimum height of 30 feet. 2. "A column of water, 1 inch in diameter and 20 feet in height, held in a strong tube screwed into the head of a full cask, will so expand its contents that it is next to impossible to construct one of sufficient strength to withstand the pressure. Such a pressure as this would drive a turbine wheel with all the power and velocity necessary to keep in operation four run of millstones." 3. Consequently an artesian well, capable of lifting a four-inch column of water 30 feet high, and pouring it into "a large receiving reservoir 15 or 20 feet above a turbine wheel, would supply water power sufficient for a very large manufactory."

Admitting our contemporary's assertion that water is projected to the height of 30 feet, and taking in connection therewith the largest yield per day, ascribed by good authority to the best Chicago well as 420,000 gallons, it is easy to calculate the horse power gained. It would be about 72,000 foot pounds per minute, which corresponds to about $2\frac{1}{2}$ horse power; or if the turbine is adjusted with 20 feet head, as suggested, there would be actually utilized about 80 per cent of $1\frac{1}{2}$ horse power, which would scarcely drive any very large manufactory. There are, we believe, about 40 wells in Chicago, with an average flow of 200 gallons per minute. Supposing, for the sake of the calculation, that all ejected their water to a height of 30 feet, the aggregate power would be 58 horse power. The depth varies from 650 to 1,646 feet, or averages 1,148 feet per well, or a total of 45,920 feet for all. Now, says the *Journal*, "the expense of boring and tubing would be about \$1,000 for each 100 feet." That is \$10 a foot or the sum of \$459,200 for making 40 wells just like those now in existence, by which just 58 more horse power would be gained, at a cost of nearly \$8,000 per horse power!

Our contemporary has been confounding pressure with power, as the second of its assertions above given plainly shows. Nearly 500,000 gallons of water a day thrown 30 feet into the air by a mere natural spring sounds gigantic, but a very small steam pump would accomplish the same with ease. It would take about five times as many wells as Chicago now has to produce as much water daily as the great pumping engines at her waterworks now raise, and about twenty-two times as many such wells as are above noted to aggregate the power of the same vast machines.

Shipping Nitro-Glycerin.

Professor Mowbray, of North Adams, started for Omaha, last week, to get permission to ship 10 tons of nitroglycerin over the Union Pacific road to Virginia City for use in the Sutro tunnel. All the other roads allow its transportation now, even the New York Central, which will not take baled hay, for fear of fire. The nitroglycerin is carried in refrigerator cars; and as it congeals at 40°, it is easily kept frozen, and in that state it cannot be exploded. It takes about ten days to ship it to the tunnel; and if it can be taken by rail, Mr. Mowbray can have a contract for 25,000 lbs. a month for a number of years. The Professor has his new factory so systematized that but two men are kept in the works, and they can make all the nitroglycerin he can sell. He uses only a tun of coal a week now, whereas he used to burn a tun a day. He buys his coal in New York, and puts it down at his works on the mountain at a total cost of \$6 a tun.

The Cat's Eye.

For scarf pins and finger rings, the cat's eye has become one of the most fashionable stones used. It is a species of the sapphire, and the most desirable color is of a yellow-green tint. It has threads of white asbestos within it, and the light is reflected from these in an intense and peculiar manner. When this stone is properly cut, a white band of light is seen floating in its interior. That changes position as the gem is moved before the eye, which peculiarity probably suggested the name by which it is generally known.

The First Brooklyn Bridge Cable Passed.

The work of carrying across the first immense wire cradle cable, of the East River bridge, was recently successfully accomplished. The great rope was attached by sister hooks to wheels which rested on the carrier cable, and the movement of the latter slowly transported it over the river. The work of connecting the cable to the anchorage is now in progress, and will occupy considerable time.

A CORRESPONDENT sends us from Franklin, N. Y., a twig from an apple tree which has at its extremity a perfectly formed and colored apple, which is a little less than a quarter of an inch in diameter, strongly fragrant. It appears to be of the Baldwin variety.

COMBINATION CHAIR AND SECRETARY.

We illustrate herewith an ingeniously constructed piece of furniture, which combines the conveniences of an arm-chair, secretary, writing table, drawers, etc., with those of a work table, scrap bag, needle and thread repository, and other appliances of the sewing room. The whole is portable, occupies but little space, and may be moved as easily as any simple household article of corresponding size.

The arm-chair, together with the case or secretary, is supported on a rectangular base frame, A. The legs of the chair rest directly upon the floor so as to ensure steadiness. Casters are provided on the legs beneath the table, so that, by lifting the chair end, the whole piece of furniture may be easily rolled about, even when the secretary is loaded with books, as the weight comes immediately above the casters. Drawers are placed, as shown, beneath the seat of the chair, and open sidewise. The inside of the secretary is arranged with movable pigeon holes for papers etc., which can be taken out, so that this space can be used as a lady's work receptacle.

The front drawer, B, serves, when open, as a support for a front folding leaf. The side drawer, C, holds pen and ink. An extension, D, on top of the secretary, is attached to the back of the arm-chair to strengthen the same, and is bracketed to support the rear folding leaf of the table. An extension bellows-shaped portfolio, E, is placed in rear of the case, and may be used as a newspaper receptacle or scrap bag. The arrangement of the folding leaves of table, D, is optional, as they may be hinged at the front, back, or end edge of the top, and may be used for various purposes, as may be desired. The door of the case is made double, and divided by horizontal strips, F, into secret compartments for money or valuable papers, and is closed by a tightly fitting piece which locks into the side of the door.

The device may be appropriately finished and decorated so as to constitute an attractive and ornamental piece of furniture. Patented through the Scientific American Patent Agency, September 2, 1873. For further particulars relative to sale of patent or royalties, address the inventor, Mr. George C. Taylor, Thibodeaux, La Fourche Parish, La.

A Mouse Plague.

The Scotch farmers appear to be at their wits' ends for means of ridding themselves of the vast armies of mice which are threatening to overrun the border country. The land is represented as resembling the ground in the neighborhood of targets for rifle practice, being literally riddled with holes. All the vegetation is destroyed in certain localities in Teviotdale, not merely the blades of grass, but the roots also, having been consumed. The farmers are encouraging the increase of hawks, owls, weasels, and other carnivorous birds and beasts.

R. HOE & CO.'S IMPROVED INSERTED SAW TEETH.

Since the introduction of inserted teeth for circular saws, their employment has steadily increased, and promises still to do so. In a plain or solid circular saw, the destruction of one or two teeth necessitates the filing down of all the others to the size and radius of the broken ones, and a continuous reduction in diameter accompanies the wear of the saw. It is necessary, in order to maintain the circumferential speed of the saw, to alter the sizes of the driving pulleys, which in turn involves a change in the length of the driving belt; and it is to these defects and inconveniences that the success of inserted teeth is mainly due. In the forms at first adopted for inserted teeth, the sockets in the saw blade are found to become gradually enlarged from the pressure, notwithstanding the spring of the blade, which for some time takes up the wear, and the teeth consequently get loose. Another and very serious objection to the ordinary form of inserted teeth, as compared with the new system illustrated in our engraving, lies in the fact that when, from the breakage of a few teeth, it is necessary to reduce the remainder, to make the saw run true and all

the teeth perform cutting duty, the clearance of the teeth becomes so greatly reduced that it is necessary in some way to restore it. To accomplish this result, special swages were invented; but the action of these swages is to spread the front of the teeth by upsetting the metal at the cutting edge; and a fatal objection to this is that, as every machinist knows, by this disturbance of the grain of the steel, its strength is greatly reduced and its cutting qualities impaired. The practical result of course is that the corners of the teeth break off when in use, especially upon coming in contact with knots. If new teeth are inserted, instead of the damaged ones, the process becomes expensive; and the new

teeth still require filing down to run true with the remainder, so that the swaging process, with all its imperfections, is generally applied.

In the present form of the inserted teeth, which is an improvement of the form shown on page 322, volume XXXII, the cost of insertion is reduced to a minimum, because the most expensive part, that is the socket, is not subject, except in exceptional cases, to wear or breakage; and the form of the cutting point or chisel bit is so simple that its cost is trifling. As a consequence, in case of breakage it is simply necessary to insert new bits, and not to file down and swage the whole of the teeth to accommodate the defects of a few

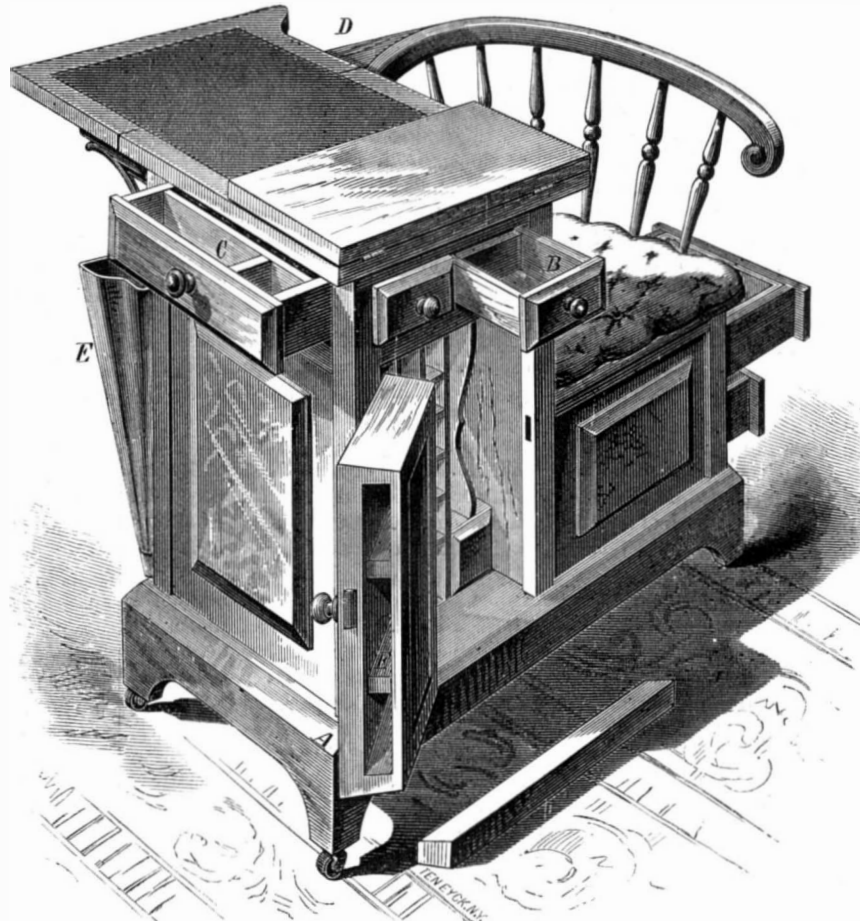
**TAYLOR'S COMBINATION CHAIR AND SECRETARY.**

damaged ones: thus not only is time saved, but the life of the teeth is greatly prolonged. In our engraving, one tooth is shown in the process of being inserted, and another in its proper position; and it will be observed that they are firmly locked in the saw without the use of either rivets or keys. The wrench used for this purpose has two projecting pins, which fit into corresponding holes in the shank as shown in our engraving, and the operation is easily effected by any one. The chisel bits are forged at one blow under a drop hammer, and every part of tooth shank and chisel bit, is made to a standard gage, so as to be entirely interchangeable. The grinding of the cutting edges is done by adjustable machinery, so that uniformity is secured in the keenness of rake, as well as in the width and clearance. The cutting

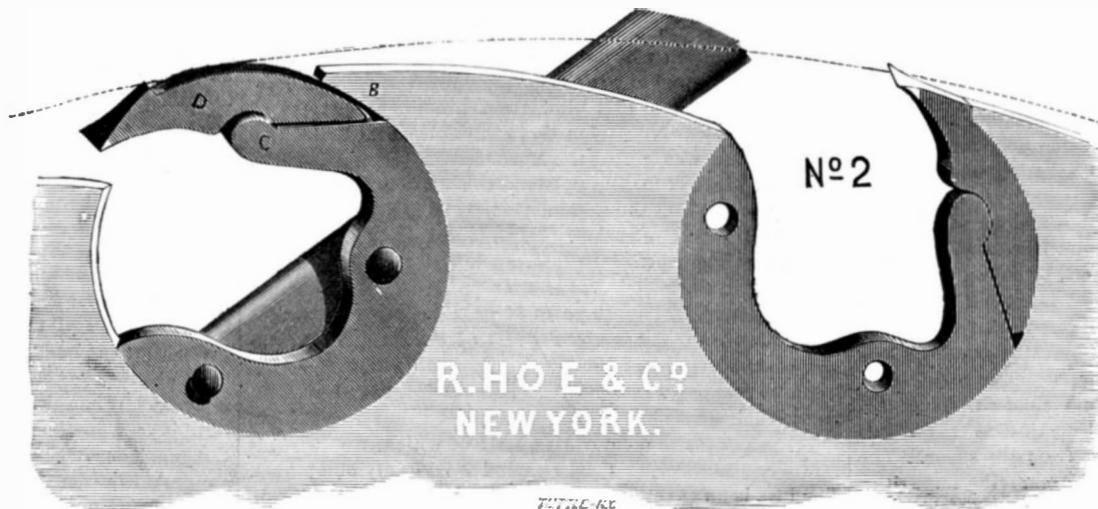
**R. HOE & CO.'S IMPROVED INSERTED SAW TEETH.**

bits, being short, are exceedingly stiff, and they are tempered as hard as a carpenter's chisel. They may be ground three times, which makes four runs for the teeth, before being worn out; and each tooth in the saw will, it is claimed, cut from one to two thousand feet of lumber, depending upon the quality of the logs and the amount of feed carried.

The saws are made from 13 to 6 gage in the thickness, and from 12 to 72 inches in diameter, the smaller sizes being admirably adapted for edging and gang saws. For further particulars, address R. Hoe & Co., 504 Grand street, New York city.

New Improvements in Aerated Bread Making.

Aerated bread derives its name from the fact that its manufacture is carried on by a process in part the same as that employed for making aerated water. In the case of aerated bread we have a mechanical process, and in the case of fermented bread a chemical process; so that perhaps machine bread would be a better name for the former product than the title now given to it. Some improvements in the manufacture have lately been introduced in England, which we are informed are of a very important character, since they admit of the production of whole meal or brown aerated bread. The improvements, which are described in the English *Miller*, consist in what is technically called the "wine process," and consists in forming a wine from malt by mashing, and afterwards setting up the vinous fermentation in closed vessels. Four gallons of the so-called wine is mixed with the necessary water for a sack of flour, drawn into a closed vessel, and aerated. It is then mixed with the flour (also in strong, closed vessels), and kneaded by arms driven by machinery. The dough formed is drawn off by machinery (thus dispensing with any intervention of the human hand) into the required loaf sizes, and at the same moment, as the carbonic acid gas passes out of it, the dough is raised and vesiculated, and ready for the oven, the whole time required for forming a sack of flour into loaves not being more than half an hour. The effect of the new wine process on the flour is, we understand, that the gluten cells of the starch are softened and broken up, and the dough is thus entirely altered in its character. Instead of being tough and harsh as formerly, the dough now becomes soft and elastic; it is easily kneaded, requiring only half the power to work the kneading arms, and the atmospheric pressure required in the vessels is only about 20 lbs. to the inch, instead of 90 lbs., as hitherto. The use of such low pressures, besides being a great pecuniary gain, is of considerable importance in giving to the bread a soft and beautiful pile-like texture.

The dough, when prepared by the new wine process, also soaks and bakes with the greatest ease, and at an oven heat of 100° less than the oven heat hitherto required for aerated bread. The starch of the flour is now changed into dextrin, while the gluten is uninjured; and the bread has a sweet and agreeable flavor, free from that acidity and bitterness always more or less present in fermented bread.

The Attendance at the Centennial Exposition.

The attendance at the Centennial Exposition for the one hundred and thirty-six exhibition days, ending and including October 14, aggregates 5,772,448 paying visitors, and 1,362,629 non-paying ones, showing a grand total of 7,088,077 people who have entered the grounds. The Philadelphia *Ledger*, whence we take the above figures, makes a number of suggestive comparisons between them and those representing the attendance at prior world's fairs. It appears that the pay admissions to the Centennial for the 136 days exceed the whole number of pay admissions at the Vienna show of 1873 for 186 days by 2,229,826, and the proportion of non-paying to paying visitors is far less. At the London Exhibition of 1851, 6,039,195 persons, paying and non-paying, attended in 141 days. Our Exposition already exceeds this by more than a million. At Paris, in 1855, the aggregate admissions were 5,162,330 in 200 days; and in London, in 1862, the numbers admitted were 6,211,103 in 171 days—both of which aggregates we largely exceed. At the 1867 Exposition in Paris, 8,805,969 people entered in 217 days. Judging from the present ratio of attendance, there is every probability that a million and three quarters will be added to the aggregate of paying visitors to the Centennial above noted, and a quarter of a million to the others, thus making over nine millions in all for 158 days, Sundays excluded, against the 8,805,969 for Paris in 217 days, Sundays included.

In its pecuniary results, the Centennial largely exceeds those of any exhibition yet held. The greatest return was at London, in 1851, namely, \$2,121,610; the next at Paris, in 1867, when it was \$2,103,677. The cash receipts for gate money during the 136 days of the Centennial were \$2,686,603.75.

ANTS.—A certain way to keep ants from sugar barrels, lard cans, and preserve jars, says one who has tried it, is to tie a string wet with kerosene around the barrel, can, or jar. Repeat the wetting of the string with the kerosene oil every few days.

THE HEMIPTERA OR BUGS.

The insects of the order *hemiptera*, or half-winged, include all those commonly called bugs, harvest flies, tree hoppers, plant lice, etc. They are sucking insects, having neither mandibles nor *maxilla* proper, but horny beaks curved along the breast when not in use, containing in grooves a series of delicate, sharp bristles, by which the insects puncture the skins of their victims. They have four wings, of which the upper are generally thick at the base and membranous at the ends, being as it were half *elytra* and half wings, whence the name of the order. In a few species, the wings are all membranous, and some are wingless as the bedbug. They undergo only a partial transformation, the *larva* and *pupa* resembling the adults, except in the absence of wings and in size; in all the stages they live in the same way, and are equally active. One species, the earthbugs (*geocorisæ*) have the *antennæ* exposed and longer than the head; most are terrestrial, but some live on the surface of the water; many emit a disagreeable odor. The wood bugs or *pentatoma* occur mostly in warm countries, where they attain considerable size, and are marked with brilliant colors; they live on the juices of vegetables and sometimes on those of other insects; they exhale a disagreeable odor, and adhere to whatever they touch. The squash bug (*coreus tristis*) and the chinch bug (*lygæus*) are species of this order.

Our illustration shows the *pentatoma grisea*, a family of the wood bugs, which may be seen, De Geer tells us, on the boughs of trees, the young following their parent like chickens after a hen. They are interesting to the entomologist on many accounts; but the gardeners find them by no means attractive. From June into autumn, the fifteen species of *pentatoma* are busy on cabbages and other vegetables, as well as on trees and flowers; vines, beans, and rosaceous plants fall victims to their fatal punctures in their search after sap. The wren and the chickadee are foes to these insects, and may do the farmer good service; but the chickadees have disappeared from many of our cities, owing to the pugnacity of the sparrows. Gardeners employ other remedies against these pests, tobacco fumigation and the application of whale oil soap being the best.

THE BURBOT.

The burbot, although a fresh water fish, is a member of the cod family, having the pendent barbs from the chin which distinguish most of the members of the *gadidæ* or cod-fishes. The burbot is ordinarily from 1 to 2 feet long, the head is flat and smooth, with the gape large, and the mouth filled with small teeth. The color is a yellowish brown, clouded and spotted on the sides, the belly being of a lighter hue. Like the eel, it conceals itself under stones, watching for young fish and insects, and it is very tenacious of life. The flesh is firm, white, and well flavored.

The *lota maculosa*, common in this country, is very similar in appearance and habits to the *l. vulgaris* above described, which is well known in England. Mr. Henry Lee relates, in *Land and Water*, that three of the common burbot were caught in the river Trent, and were offered to the directors of the Brighton Aquarium, and accepted; but before they could be despatched on their journey, the largest of the three (he was but 14 inches long) swallowed his two companions.

The burbot is very hardy, and, like the carp, will live for a long time out of water, if kept moist, and fed occasionally with worms and small fishes. It is said it will thrive in ponds if well fed on bullock's liver, etc. Its growth, however, is probably not very rapid, if the statement be correct that it does not spawn till its fourth year.

The large, three-lobed liver of the burbot has always been regarded as a great delicacy. Black tells of a certain Countess of Beuchlingen, in Thuringia, who spent the greater part of her income on this luxury. This liver was also supposed, according to Marsili, to be an efficacious "love philtre," and the oil from it was esteemed as a valuable emollient of corns and callosities. From the air bladder—small as it is, though large in proportion to the size of the fish—isinglass is made. The skin, cleansed, stretched, and dried, is used by the country people in many parts of Russia and Siberia instead of glass for the windows of their dwellings, and is as translucent as oiled paper. It is also utilized by some of the Tartar tribes as

material for their summer dresses and the bag in which they pack their animal skins. The fishermen of the Oder, when they catch more burbot than they can sell, cut the fattest of them into strips, dry them, and use them as matches. The roe, which, by Willoughby's computation, contains about 128,000 eggs, is deemed unwholesome, if not poisonous.

The turbot is also indigenous in almost all the rivers and lakes of Northern Europe, India, and Northern Asja, and also in the Hudson's Bay territories. It is common in Ger-

originality that his suggestion, of even so Utopian a scheme as the one above referred to seems at first sight to be, secures for it thoughtful consideration and possible reduction to practice, where otherwise it might merit but passing notice. Hygeia, as the model city of health is appropriately named, was described in a presidential address delivered by the author before the Health Department of the English Social Science Association, at the Brighton meeting of a year ago. This address, revised, is now published in pamphlet form.*



PENTATOMA GRISEA.

many, Denmark, Sweden, and Russia, and is especially abundant in the lakes of Geneva and Leman. If it be true that it was introduced into the former from Neufchatel, and thence to Lake Leman, it furnishes a good example of successful acclimatisation or naturalisation. It is also met with in the Italian lakes Maggiore and Lugano, and exists in most of the streams in the east of France, but is not very abundant anywhere in that country. In England it is a local fish, being found chiefly in the northern and midland counties, and especially in the Trent. Mr. Couch suggests that the burbot may probably be an imported fish, and thus has not been generally distributed. From its tenacity of life we may conclude that it might easily be introduced into any deep and slowly moving stream; but, as it is a ravenous de-

The bricks are perforated transversely, and at the end of this there is a wedge opening, so that the walls in this way become honeycombed, and admit a constant body of air, which can be heated by the fire grates in the house. The bricks inside the house are decorated, so that no other finish is needed, and the layers of poisonous paper and moldy paste are thus avoided.

The chimneys are all connected with central shafts, into which the smoke is drawn after being passed through a furnace to destroy the free carbon, so that it is discharged colorless into the open air, and its nuisance thus obviated. The roofs of the houses are to be gardens, tastefully laid out. The kitchens, instead of being on the ground floor, are located in the garrets, so that no smell of cooking is ever disseminated through the houses and the transportation of food is rendered easier, since the heavy dishes are taken down and the light, empty ones only carried up. No carpets are permitted, the floors being of hard wood, and kept clean by beeswax and turpentine, by which process the air is ozonized and rendered fresh. Twelve hundred cubic feet of air is allowed to each sleeper in bed rooms, and from the sleeping apartments old clothes, etc., are rigorously excluded. Lifts are provided for transporting material from floor to floor, and the heating apparatus consists in an air box in every room, which, distinct from the chimney, communicates by an opening into the outer air, and by another opening into the room. When the fire in the grate in the room heats the iron receptacle, fresh air is brought in from without, and is diffused into the upper portion of the apartment.

All pipes enter the houses from beneath; and as they pass

through the arched subways, access to them is always convenient. The brick sewers run along the floors of the subways and empty into three cross main sewers. They are trapped in each house, kept well flushed, and ventilated into tall shafts by pneumatic engines.

As regards the personal habits of the population, drinking and smoking will be unknown, for saloons and tobacco-nists' shops will be excluded. Working men and women

*Macmillan & Co., N. Y. publishers

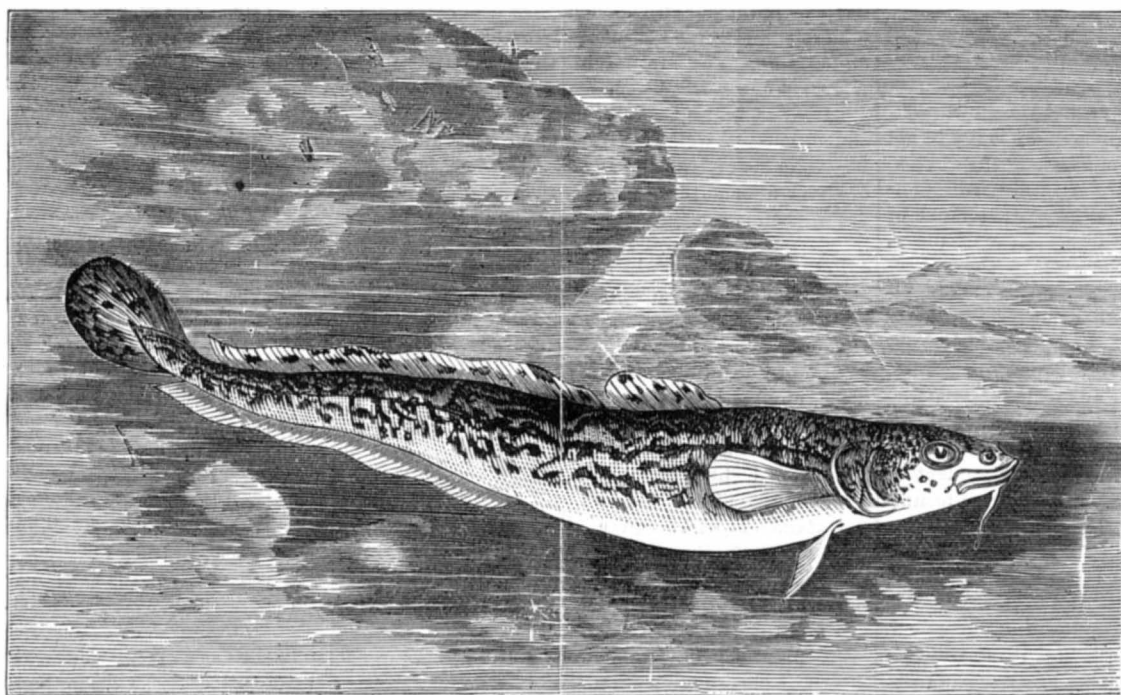

THE BURBOT (LOTA VULGARIS).

vourer of small fry, as well as of fishes of larger growth, its presence in some rivers might not be desirable.

Hygeia---The Model City of the Future.

It has recently been announced that a site has been purchased in England whereon is to be erected a model city, conceived by Dr. B. W. Richardson. Dr. Richardson is well known as one of the first sanitarians living, a close and able investigator, and a man whose previous works are of such

will not be permitted to carry work home, but must hire workrooms in buildings set apart for that purpose. There is a great deal of good sense in this provision. Dr. Richardson says that work carried into squalid tenements is often a cause of the spread of disease. "I, myself," he adds, "have seen the half-made riding habit, that was ultimately to clothe some wealthy damsel, act as the coverlet of a poor child stricken with malignant scarlet fever." In order to avoid dissemination of disease by soiled linen, public laundries are established under municipal direction, and to these alone must be sent such clothing as is not washed at home. Public hospitals are established in various parts of the city. We have not space to enter into the details of these, and it will be sufficient to say that their planning is the result of Dr. Richardson's long experience in the great city of London hospitals. There are no insane asylums, and no poor houses; the few who would occupy such institutions are to be placed in houses licensed as asylums, but in no wise different from other buildings in the city. No persons are to be "badged and badgered as paupers," the author significantly remarks.

Of course the model city contains baths, gymnasia, public libraries, art museums, in brief all requisites for mental and physical culture. There is a municipal medical staff, under whose supervision every assumable disease and probable cause of disease is subjected to investigation. The sewage is conveyed to a farm and utilized; the water supply is uncontaminated and led always through iron pipes. An immense ozone generator makes ozone, which is "laid on" in private houses for disinfecting purposes. All animals for food and the modes of slaughtering them are under rigid inspection, and the killing is preceded by rendering the brutes insensible by passing them through a "narcotic chamber." Finally, there are no marked graves, no reserved spaces in cemeteries. The dead are buried in wickerwork coffins, which, with their contents, decompose and mingle with the earth. The only memorial monuments are tablets in a spacious covered hall or temple.

Dr. Richardson stops here, for he reaches the confines of his legitimate territory as a sanitarian. His plan, he says, will reduce the rate of mortality to 8 per 1,000 of the inhabitants for the first generation, and to 5 per 1,000 eventually. That this is a vast decrease is obvious when we compare this ratio with that of New York city, where, according to the latest statistics, the weekly mortality averages 82 per 1,000. But need we stop here? Certainly the inventor can step in where the hygeist ends; and may not this model city of health be the model city where are congregated the newest triumphs of inventive genius? There, perhaps, will be located the telegraph which, already in existence, enables us to transmit sound, and so hold converse over long distances, or to lead music into our houses as easily as the water or gas; there will be congregated all those wonderful automatic appliances which reduce the manual drudgery of housework to little more than mere supervision; in those underground railways, we may hope to see speed attained beyond all precedent, yet at no sacrifice of safety; there arms of metal controlled by electricity, by steam, by compressed air, by hot vapor, will relieve arms and muscles of flesh and blood; and then, physical labor being reduced to its minimum, may we not look for that cultivation of the intellectual man which shall lead to still greater attainments? Will not means be devised for developing our dual brain? May we not hope to use our left hand as easily as our right, our feet as advantageously as our hands, in all species of that which is now called handiwork? And then what higher race of men will be evolved by heredity, surrounded by such environment? Is not Dr. Richardson's Hygeia, after all, but the first step toward the rapid development of the future perfect man?

MINERALS AT THE CENTENNIAL.

Much disappointment has been expressed by many in not finding a better display of American minerals at the Centennial. We take an honest pride in the natural productions of our country, and perhaps we had expected too much of it, and hence the disappointment. Another cause of disappointment lies in the arrangement; there are a great many fine minerals scattered here and there, all over and in all the buildings, which, if brought together and systematically arranged, would make a fine show. The present arrangement, which is geographical, is of course the best for exhibitors, for each State and country gets due credit for what she exhibits; it is also the best for any one wishing to learn what may be the mineral wealth of a given State; it is interesting to those about to emigrate; but for the student of mineralogy, the order followed in our museums and technical schools is better.

THE MINERAL ANNEXE.

If we enter the mineral annexe at its eastern extremity, and pass down towards the Chinese exhibit of teas, figures, and curiosities, we find ourselves in the section devoted to the various States, beginning with that of Illinois. This State makes rather a poor show of minerals, with the exception of lead ores, especially of galena, of which there are some fine crystals, also calcite. The collection of antiquities from this State is, however, very fine. Next we see a large block of crude native sulphate of soda (Glauber's salts), some 4 feet square, from Wyoming territory. This block was taken from a deposit of 100 acres in extent and 10 feet thick, and appears to be quite pure. Pennsylvania follows, and its exhibit consists mostly of coal, iron, and oil, with some geological models, and a series of preparations made by Professor Schorlemmer, of Owens College, Manchester, England, illustrating the composition of petroleum.

Michigan is next, and far exceeds in interest any of the

above. Her specialties are native copper and silver, which are well represented here. First we see a cubical mass of copper, 3 feet on a side, which has been cut from a mass weighing 76 tons. Then we have ancient stone tools used by a prehistoric race for working the copper: copper minerals of different kinds; a conglomerate containing 5 per cent of copper; a large number of chlorastrolites, a green mineral peculiar to the Lake Superior region; native silver, and a set of miniature tools, like those now used in copper mining, made from the native silver and copper just as it comes from the mine; iron ore, and a geological section of the iron district; lastly an Indian canoe 10 feet long, made of birch bark.

The next State is Missouri, where lead and zinc abound. Here are some coal fossils of *lepidodendron*, also malachite, azurite, kaolin, geodes of amethyst, and other minerals. The zinc ores, from Dade county, and blende, from Joplin and Graten, are especially worthy of notice.

Ohio is chiefly noticeable for the mound builders' relics, a very large and fine display being made by the State Archaeological Association, and another by L. M. Hoseas, of Cincinnati. Some of these indicate the possession of considerable skill and taste on the part of the extinct race that once inhabited that region. The building stones of the State are shown in the Ohio State building.

Next in order is Wisconsin, with her iron, lead, zinc, and copper. Here is a huge mass of smithsonite, or carbonate of zinc, which the miner calls dry bone, from its peculiar appearance. Here, too, are tools made of stone and of copper, which carry us back to prehistoric races.

Iowa is chiefly noted for its display of coal and lead. The geological formation is illustrated by a cabinet in which thin strips of the rock in each strata are placed one above the other, in cases 6 feet high and 18 inches wide. There are 12 of these cases, in which are shown all the various formations, from the St. Peter's sandstone up to the drift. Here for the first time are seen some skulls of the mound builders, also some large geodes.

Indiana exhibits kaolin in large quantities, also coal and iron ore. Delaware also exhibits iron and kaolin. The Schuylkill Company exhibit a block of coal weighing 14 tons 13 cwt., in this annexe, and here, too, is some statuary marble from Rutland, Vt., with photographs of the quarries. It seems surprising that so few mines, mills, or quarries have thought it worth their while to procure photographs of their works, for they both attract attention and impart, in an easy way, a deal of information.

The west end of this annexe is devoted to the Chinese and to some process for making artificial stone, by the aid of steam and carbonic acid.

In the smaller mineral annexe is a cabinet, showing a section, in miniature, of the Warrior coal measures of Alabama. The South Carolina exhibit embraces a model of the washers used in preparing nodules of phosphate of lime mined by the Charleston Mining Company on the Ashby river, S. C.

The most attractive exhibit in this building is that from Mount Union College, Ohio. It embraces a gorilla from Western Africa, a koala from Australia, an ant eater from Brazil, a kangaroo rat from Australia, and a *galeopithecus* from the Philippine Islands.

A few States, including Kentucky and Tennessee, have their exhibits in the United States Government building; others, New York among the number, have none worth mentioning. Kansas and Colorado have their minerals with their other products, including Mrs. Maxwell's animals, in their own State building. Colorado is particularly rich in minerals, and an enterprising dealer has constructed some toilet or jewel boxes, which he has covered with Colorado minerals, and these he sells in large numbers at the Colorado building. The prettiest of these minerals is the green felspar, known as amazon stone, which is found almost exclusively at Pike's Peak. Silver ores in abundance are also shown here, as well as tellurium minerals and many others less valuable or beautiful. About the door lay huge masses of silver ore and bituminous coal.

THE MAIN BUILDING.

Returning to the Main Exhibition Building, we find there a collection of Rhode Island minerals, very creditable to that little State; also some interesting relics, arrow heads, hatchets, etc., from the same State. There is a pretty good collection of Californian minerals, said to contain 17,000 specimens, number of species not stated.

From Maryland, we have some handsome *verde antique* marble, chromic iron sand from Delaware county, Pa., and crystals of bichromate of potash made from it.

The Passaic Zinc Company, of New Jersey, exhibit some fine specimens of calamine, also zincite and willemite, together with the metal made by them from these ores. The Corroding Lead Company exhibit pigs from the furnace, refined, soft, and desilverized lead, flake litharge, slag, skimmings, dross, regulus from matt, etc.

Joseph Wharton, Camden, N. J., makes the best and almost the only exhibit of nickel ores, ordinary nickel ore, pyrrhotite and millerite, and a set of salts, anodes, etc.

Not far from here is a model of a portion of an anthracite colliery, the Warton vein, Beaver Brook Pa., on a scale of 30 feet to the inch. The superincumbent strata being partly removed, the coal bed is exposed, showing the dip, synclinal, anticlinal, slopes, galleries, coal breakers, and other important parts, carefully labeled and intended for educational use.

There is a curious stone here from Mumford, Munroe county, N. Y., which consists entirely of vegetable petrifications, chiefly leaves and twigs. Although it looks very fragile, it must possess considerable strength, for we are told

that a church has been built entirely of this stone. Adjoining this is a large mass of infusorial silica, the so-called electro-silicon, from Nevada. This substance consists entirely of the siliceous remains of microscopic animals, and presents, when viewed under the microscope, many beautiful forms. Its chief uses are in the manufacture of dynamite, and as polishing powder.

Adjoining this again is a large and beautiful collection of American minerals, with a few foreign ones, exhibited by Professor A. E. Foote, of Iowa. Most conspicuous among these is the green amazon stone from Pike's Peak, Colorado. Then come some very powerful natural magnets, from Magnet Cove, Ark., a great variety of quartz crystals, single and in masses from the Hot Springs, a crystal of smoky quartz which is four feet long, from Pike's Peak, rose quartz, amethyst, petrified moss, green wavellite (unusually fine), native copper, petzite, stalactites and stalagmites, agates, landscape marble, etc. There is also a set of specimens put up for students' use, which embraces many rare minerals, and yet comes within the reach of almost every one.

In a cabinet by itself is a collection of minerals from the line of the Texas and Pacific railroad, also collected by Professor Foote. The most beautiful or rare are the turquoise and embolite (chromo-bromide of silver), from New Mexico, sylvanite (telluride of gold and silver), from Colorado, and moss agate, from Texas.

Iron and coal, as well as the precious metals, have been treated of elsewhere from an economic point of view; but we cannot refrain from calling attention to an unusually large, hollow mass of hematite iron ore, which constitutes a small cave with jet black walls, that look as if they had been varnished.

THE UNITED STATES GOVERNMENT BUILDING.

Carefully guarded in a fireproof safe are several of those exceedingly rare crystals, namely, pure gold. Not far from these are specimens of silver ore, valuable but not very beautiful, from Comstock and other celebrated lodes. Here, too, are many fine specimens of the purest sulphur, borax in abundance, and many other things which will be very valuable when civilization, now on its western march, shall have reached their hiding places. We also notice some large aerolites.

In cases against the walls are arranged some loan collections worthy of notice, especially those of Messrs. Jefferis, Perry, & Wilcox, of Philadelphia. One crystal of apatite, 4 or 5 inches long and 2 inches thick, was quite unequaled anywhere else. Mr. Fletcher makes a creditable exhibit of minerals from Bergen Hill, some of which are very beautiful.

CANADA.

The Canadian mineral exhibit is in the Main Building, and has been pronounced by competent judges one of the best on the grounds. Apatite, amethyst, native copper, iron, coal, and oil really deserve more notice than our space at present permits.

FOREIGN EXHIBITS.

Of the South American countries, Chili stands first. The collection of Emilio Escobar, embracing 445 specimens, is valued at \$30,000. It consists chiefly of native silver and silver ores, including several specimens of beautifully crystallized proustite or ruby silver (sulphide and arsenide of silver), from Chañarillo. Some of the crystals are over 3 inches long; the finest specimen is valued at \$4,000. The copper minerals are also very beautiful, especially the atacamite (chloride of copper), malachite (carbonate of copper), and many others; also cobalt ores, borates, sulphur, cinnabar, etc. The process of amalgamating silver ores is exhibited in a separate building, near the glass house.

Brazil and Mexico make a very fair show. The Mexican marbles, from their rare beauty, attract much attention. A single mass of metallic silver 6 feet in diameter, weighing 4,002 lbs., and worth \$72,000, attracts much attention from its value.

Russia is the only European country whose mineral exhibit fairly represents her mineral wealth. The exhibit from the Museum of the Imperial School of Mines is very fine. Beginning with native platinum and its associate metals, palladium, rhodium, iridium, ruthenium, etc., we next see some beautiful specimens of *aqua marina*, a bluish-green variety of beryl, emeralds, garnets, and zircons. Ouvarovite, an emerald green garnet, named after the Russian minister Uvarov, large pieces of jasper, nephrite, and topaz, in crystals 6 inches long, are some of the curiosities of the collection. The crystals of pure white rock salt, and of mica, are worthy of notice. Malachite, *lapis lazuli*, rhodonite, and labradorite, the great Russian specialties, are represented here; but a much finer display is made by Hoersch & Woerffel, who exhibit a large number of articles made from these beautiful stones, such as vases, table tops, cabinets, mantlepieces and jewelry.

Practical Germany limits her mineral exhibit to products of use in the arts: amber, lead ores, petroleum, and Stassfurt salts. The collective exhibit of potassium and magnesium salts from Stassfurt is very complete, tastefully arranged, interesting, and instructive. Their discovery has created a revolution in the alkali industry, and it is now no longer necessary or profitable to destroy fine forests to obtain our supply of potash.

Great Britain makes a very poor show. Some bricks and tiles, chalk and cement, some polished granite from Aberdeen, and we have done. Italy is rather better, for she exhibits a fine collection of polished marbles, besides sulphur and alabaster.

The exhibit of Hawaii, although small, is very interesting, embracing as it does several sets of volcanic minerals and

lava from the crater of Kilauea. Among these is a bird's nest, made of pelee's hair, a substance resembling our mineral wool, and formed in an analogous manner, by the wind blowing over melted lava.

Diamonds in the rough, and diamondiferous soil with a diamond in it, are shown in the pretty little exhibit of the Orange Free State.

There are a few minerals scattered about elsewhere, but none of much value

CENTENNIAL NOTES.

The Siamese exhibit, which has been six months on the way to the Exposition, has arrived, and is located in the Navy Department section of the Government Building. The collection was made under the direction of the King of Siam, and is a present to the United States. Whatever might have been its original condition, the present state of that portion of it which is visible is sad to behold. Under a covering of canvas there lie bundles of apparently broken parts of wagons, a couple of rude wheels, dried palm leaves and other vegetable products, and a countless number of *et ceteras*, massed together and seemingly defying any attempt to resolve them into order. On the tables near by are displayed several curious peaked and pointed head dresses covered with spangles and gilding, and a collection of models of the long low snake-like boats peculiar to the Malays. All are tarnished and dingy, and the marks of a severe voyage and not over gentle handling are everywhere apparent.

THE GERMAN EXHIBIT

was so mercilessly criticised in the letters sent home by Professor Reuleaux, the chief German commissioner, that it has become rather the fashion to speak slightly of the display as a whole. This is decidedly unjust, for there are very many admirable features, amply sufficient to compensate for the over-abundance of effigies of Kaiser William and Bismarck, and the exhibit of cheap jewelry and chromos. For instance, there are Count Wermgerode's reproductions, in cast iron, of many famous works of art. These consist of helmets, shields, sword hilts, pitchers, urns, and plates, covered with exquisitely molded figures in bas relief. The casting is remarkable for its perfection in details, and will be quite a revelation to most foundrymen. One plate is left just as it was taken from the mold, with much of the sand still clinging to it, and the sharpness of outline attests the excellent work of both molder and founder. The objects are finished with a coating of brown powder, so that they cannot be distinguished by the eye from real bronze, while their cost is of course much cheaper. The ivory display is also very fine. Above the tall ebony case in which the objects are placed is a large pair of elephant's tusks, surrounded by smaller tusks, graduated according to length, and terminating in the short tusks of the walrus. Within the case are pianoforte keys, billiard balls, combs, chessmen, and a handsome collection of carved articles. A curious species of ivory is also exhibited in the long straight spiral horns of the narwhal or unicorn fish of the northern seas.

Germany gives to her pottery from the Royal Porcelain Manufactory, Berlin, the post of honor in the center of the building. To describe this superb display is scarcely possible, since the exquisite delicacy and artistic coloring of the ware render each piece an object of high art. Many of the vases are of very large dimensions, indicating the great skill brought to bear in their molding. The chemical exhibit in the German Department we have already described in other articles. Perhaps the most instructive contribution in the whole large display is one of the coal tar distillates and aniline colors, so arranged as to show the progress of invention in drawing from the dull heavy coal tar its oils, and then the beautiful shades of red, violet, blue, green, and orange, and finally that great triumph of the chemist's skill, alizarine or artificial madder, which surpasses the true madder root in brightness and fastness of color. The success which so far has rewarded investigators leads to the belief that the problem of manufacturing artificial indigo will be solved. One of the latest discoveries in the field of coal tar colors is eosine, which promises to supersede the costly cochineal.

There are three exhibitors of paraffin and mineral oil manufactured from peat. This industry is, in Germany, confined to Saxony, and the total annual value of the product is about \$4,000,000. The oils are mainly used for lubricating purposes, the poorer sorts alone being employed for the manufacture of illuminating gas and stearine candles. One very large block of stearine is exhibited, which is nearly a pure white. A large display is made of the famous Johann Maria Farina cologne. The descendants of Farina claim to be the only possessors of the secret of making the perfume. We shall describe other interesting German articles in future articles.

In the Italian section there is a model of

A NEW JURY RUDDER,

a sketch of which, Fig. 1, we give herewith. It is always customary for vessels to carry to sea the material for making a temporary rudder in case that very important appendage should become disabled, and there are many ingenious inventions for putting together spare spars and pieces of timber in rudder form. When the new rudder is made, however, the difficulty is by no means surmounted. The problem then is how to get it in place; and when a ship is rolling heavily in the trough of the sea, this is an exceedingly troublesome and perilous operation. The plan proposed by M. Raffaele Cagliesi, of Ancona, offers first a simple construction, which is such that the device may be folded into a very small space, and so easily stowed; and, second, an easy means of shipping the rudder. The appliance is made of

heavy iron plates pivoted, like a fan, to a recessed block of metal at the center of an iron post, A. The upper plate is fast to the post and the others may be folded up beside it, so

Fig. 1.

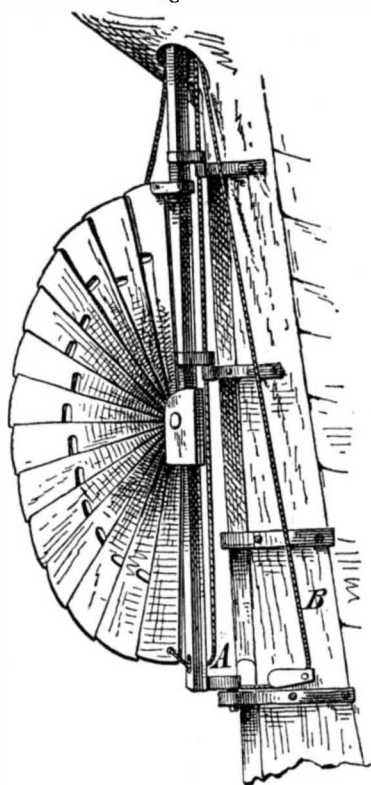

that when the device is thus placed it may be passed downward through the rudder hole. On the post are pintles which slip into gudgeons on the stern post, thus hinging the rudder in place. And also on the stern post is a sheave, B, through which a chain or rope is kept passed; so that, when it is necessary to place the rudder in position, one end of this rope is attached to the lower pintle, and by pulling on the other end the pintle is quickly drawn into the socket. In the lower part of the post, A, there is a sheave through which another rope, attached to the lower rudder plate, is rove, and which likewise leads up through the rudder hole. By pulling on this after the rudder is placed as described, the fans or plates are expanded as shown, while they may be closed to remove the apparatus by means of a rope shown on the opposite side.

In previous articles we have described the growing South African industry of ostrich raising, which, it has been suggested, might be successfully carried on in this country. In the annexed engraving is represented

THE LEVIATHAN INCUBATOR

(exhibited in the Cape of Good Hope section), wherein the huge eggs are hatched. The apparatus consists of a middle steam chamber of metal (Fig. 2), which is kept constantly

Fig. 2.

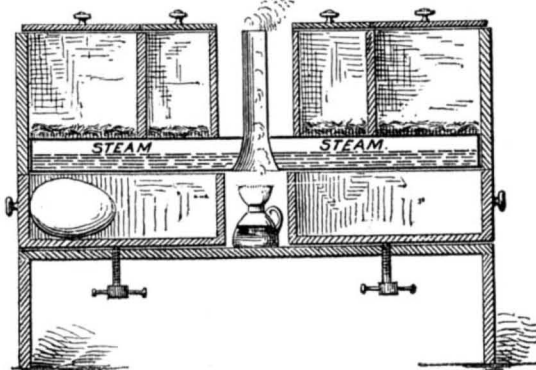

hot by a lamp or furnace beneath. Below this are drawers in which the eggs are first placed, and these, by means of the screws shown below, may be raised until the eggs are brought almost in contact with the warm surface above. In these receptacles the eggs are kept for two weeks at a temperature of 102° Fah. They are then removed and placed in the inner pair of compartments, shown above, for another

Fig. 3.



fortnight, at a temperature of 100°. At the end of this period the eggs are carefully extracted, and a small hole is chipped in each shell at the point opposite the chick's head. They are next replaced and kept in the same compartments for two weeks longer at 98°, when the hatching takes place,

and the young birds are placed in the outer upper receptacles, and there remain for two days. The compartments above, it should be noted, have bottoms of lamb's wool, which come in contact with the steam chamber below.

The two days' old chick is also represented in the engraving, Fig. 3, beside an egg, so as to show the relative size. The egg is about 7 inches in length and the bird some 13 inches in height. The chick is fed on rice, and when it reaches the age of seven days is worth \$50 in gold. Nearly 20,000 birds, we are informed, have been hatched at the Cape of Good Hope by apparatus of this description. The machine is frequently made of sufficient size to hold 115 eggs at a time.

ASTRONOMICAL NOTES.

OBSERVATORY OF VASSAR COLLEGE.

The computations and some of the observations in the following notes are from students in the astronomical department. The times of risings and settings of planets are approximate, but sufficiently accurate to enable an ordinary observer to find the object mentioned. M. M.

Positions of Planets for November, 1876.

Mercury.

Mercury should be looked for before sunrise during October and the first half of November. On November 1, it rises about 5 A. M., and sets at 4h. 15m. P. M. On November 30, Mercury rises at 7h. 4m. A. M., and is too near to the sun to be seen.

Venus.

Venus is still brilliant in the morning, rising on the 1st at 2h. 58m. A. M., and setting at 3h. 15m. P. M. On the 30th, Venus rises at 3h. 58m. P. M., and sets at 2h. 45m. P. M. Although its apparent diameter is much smaller than in the summer, it is still a very beautiful object, and can be seen all through the month. On the 28th, Mars, at this time very small, can be recognized by its nearness to Venus.

Mars.

Mars is one of the planets visible to the naked eye, but it is very small in November, and can be seen only in the morning. It may be known from the circumstance of its keeping nearly the same diurnal path with Venus, at a little less altitude.

Mars rises on the 1st at 4h. 14m. A. M., and sets at 3h. 47m. P. M. On the 30th, Mars rises at 3h. 56m. A. M., and sets at 2h. 37m. P. M. On November 28 Mars and Venus will have nearly the same right ascension, and will pass the meridian with only a few minutes difference of time.

Jupiter.

Jupiter is very little seen in November. In the early part of the month it sets about 6h. 10m. P. M., and can be seen in the southwest immediately after sunset. On the 30th, it rises at 7h. 26m. A. M., and sets at 4h. 39m. P. M.

Saturn.

Although Saturn is low in altitude (in this latitude not above 26° for the whole month of November) it is much the most interesting object in the evening sky. With a telescope of low power, its wonderful ring can be seen, and at least one of its many satellites. On the 1st, Saturn rises at 2h. 16m. P. M., comes to the meridian at 7h. 30m., and sets at 43m. after midnight. On the 30th, Saturn rises at 23m. after noon, comes to the meridian at 5h. 38m., and sets at 10h. 53m. the next day. Saturn is among the stars of *Aquarius*, but so much brighter than even the brightest of the constellation as to be readily known to be a planet.

Uranus.

On November 1, Uranus rises a few minutes after midnight, but a short time before the bright star Regulus, and 14° north of it in declination. The planet can perhaps be found by its nearness to this bright star; it approaches the star until the 29th. On the 30th, Uranus rises at 10h. 15m. P. M., and sets at 11h. 58m. the next morning.

Neptune.

Neptune rises on November 1 at 4h. 41m. P. M., and sets at 6h. 1m. of the next morning. On the 30th, Neptune rises at 2h. 45m. P. M., and sets at 4h. 3m. the next morning. This planet is so far distant from the earth that it can be seen only by means of the best telescopes.

Sun Spots.

The report is from September 28 to October 17, inclusive. The photographs of September 28 and September 29 show two large groups of spots coming on. These were seen till October 3; but after that date, clouds prevented observation and photographing till October 9, when the sun's disk appeared to be free from spots. On October 13 a group of small spots was seen on the western limb. These had not been discovered before, probably on account of clouds. This group was last seen on October 17, but, contrary to the usual behavior, it had appeared to increase in size as it approached the limb. The return of this spot may be looked for after two weeks.

Small Arms for Russia.

Smith & Wesson, Springfield, Mass., have a new contract with the Russian government for 20,000 pistols, which are to be the same as those they have making, and include the automatic ejector. The firm have now manufactured some 130,000 for this government, their first contract being taken in 1871. This contract, by the way, was concluded for the government by a gentleman bearing the euphonious name of Captain N. Kouschavewitch.

THE Australian gum tree, *eucalyptus globulus*, well known for its antiseptic qualities, has recently been found to yield a fragrant resinous oil, containing a substance homologous to camphor.

Patent Law Reform in England.

At a recent meeting of the British Association at Glasgow, a paper was read "On Recent Attempts at Patent Legislation," by Mr. St. John Vincent Day. In the discussion which followed, Mr. F. J. Bramwell spoke at some length. It seems to be thought, he said, that lawyers have a special claim to dominate in patent legislation, perhaps on account of the great gravity of the legislation which arises out of patents. This notion of excessive litigation in reference to patent matters is absolutely unfounded. An eminent barrister connected with patent litigation, when it does arise, had assured Mr. Bramwell that on an average of many years only nine patent actions or suits go to the stage of a primary decision in each year; and an examination of the files of the *Times* for the year ending November, 1874, showed the accuracy of the statement which had been made. Mr. Bramwell then proceeded to the question of the official examinations into novelty and frivolity. He had long had very great doubts whether it is desirable to make an examination even into novelty; but if such an examination be made, the very first care must be to appoint a sufficient number of men of scientific attainments or of good experience. This is a difficult task in itself; even when the greatest care has been taken, it is certain that some mistakes will be made, and some hardships will be suffered, and we have to consider whether the advantages to be attained are sufficient to justify the risk. After all, what is the benefit to be derived from an examination into the novelty of an invention? Sometimes, it is said, it is to protect the inventor. The answer to that is that, if you make the inventors into classes separate from the community at large, the inventor says: "For heaven's sake, leave us alone; we need not be protected against ourselves." But others put the desirability of the examination into novelty on broader grounds. They say it is undesirable that a patent should be granted for a thing which is not new, because the public may thereby be prohibited from using something which the patentee claims as his invention. The answer to this is that a patent granted for a thing which is not new is, if not void, voidable, and then in truth a very small amount of harm results. Mr. Bramwell then went on to illustrate his meaning by reference to the inventions of James Watt, Dr. Potts (the inventor of the method of driving piles by the exhaustion of the air), and Dr. Siemens, all of whom he urged would, probably, have been refused a patent, by the examining body. It appeared certain that we should not have an examination as to frivolity; and if we were to have an examination as to novelty, that examination should be fenced with precautions to prevent an inventor being injured by a wrongful decision. It was recommended by the committee of the Society for the Amendment of the Law that a patentee should have, notwithstanding the adverse report of the examiner, a right to demand his patent if he still so pleased, but that the specification should have appended to it the decision of the examiner, and that any person bringing an action under such a patent should be compelled to give security for the costs; and that in the event of his failing, and failing on the grounds put forward by the report of the examiner, he should pay the whole costs of his opponent as between solicitor and client, and not the mere taxed costs. Some protection such as this against the mistake of novelty examiners was absolutely necessary.

REMARKS.—In this country we have had the system of official examination in vogue for forty years; and if it were possible for Englishmen to learn anything, they might profit from our experience. In the early days of our system, it was the common practice of the Patent Office to reject even highly meritorious inventions; just as they now do at the Prussian Patent Office. But that method gave great dissatisfaction, and was so discouraging to inventors, and so obviously contrary to the spirit of the Constitution, that it had to be abandoned. At present the examinations are substantially limited to the ascertainment of identities of inventions. If the invention for which a patent is asked is identical with one already patented, the petition is rejected. If there is an iota of difference, the new patent is allowed. This is the only safe rule to follow; it works well, and gives satisfaction; except in cases where the examiner is so stupid as to be unable to see the difference between tweedle-dum and tweedle-dee. Property in patents never commanded such high valuations here as at present, notwithstanding the fact that the number of issues, now nearly 15,000 a year, is steadily increasing. The Supreme Court of the United States taught our patent officers a good lesson concerning the necessity of liberality to inventors, when it forbade the practice of citing old rejected cases against new applicants. This decision so limits the scope of official examinations that they are of no special importance now, if indeed they ever were; and nobody would be hurt if the system were abrogated. We agree with Mr. Bramwell that a patent granted for an old invention is good for nothing, and the issue of such a patent does very little harm.

Chromic Inks.

As long ago as 1848, Professor F. Runge invented what he called a chromic ink, from its containing chromate of potash. His directions for its preparations, published at the time in *Dingler's Journal*, were as follows; A decoction of logwood is first made in the proportion of 10 to 80, that is 10 lbs. of logwood is boiled with enough water to produce 80 lbs. of the decoction. To 1,000 parts of this logwood extract, when cold, is added 1 part of yellow chromate of potash, stirring rapidly. It is ready for use at once. Gum and other additions are injurious, he says, to this ink.

The following year W. Stein proposed an improvement on Runge's ink, saying that the great fault of this ink was that it soon became thick, like sour milk. This he overcame by adding four grains of corrosive sublimate to each bottle.

This would restore thick ink to its pristine quality, and improve its color changing it from deep indigo blue to pure black.

In 1867, C. Puscher described a new ink similar to the above, made as follows: Boil 10 ozs. of logwood in 20 ozs. of water, then boil again in 20 ozs. more of water, and mix the two decoctions; add 2 ozs. of chrome alum and boil another quarter of an hour. One oz. of gum arabic is added, and we have 25 ozs. of deep black ink.

Böttger says that a simple method of preventing gelatinizing in chromic ink is to add to the water in which the extract is made some carbonate of soda. His method of operation is as follows: Dissolve 15 parts of extract of logwood in 1,000 parts of distilled water to which 4 parts of carbonate of soda has been added at boiling heat, and add 1 part of yellow chromate of potash dissolve in a little water.

Recent American and Foreign Patents.**NEW MECHANICAL AND ENGINEERING INVENTIONS.****IMPROVED SHOVEL-GRINDING MACHINE.**

William A. Meyer, North Easton, Mass.—This consists of a series of swinging shovel-blank-supporting frames, that are journaled in a shaft placed on pivoted and spring-acted standards. The blank holding frames and standards are supported on a traversing carriage that feeds the blanks successively to a rapidly revolving and adjustable grindstone, that grinds the entire surface of the blanks. There is a revolving eccentric cam, supported on a pivoted and sliding carriage, which is capable of being moved toward or from the shovel frames, as required, by the articles to be exposed to grinding.

IMPROVED BOAT-DETACHING APPARATUS.

William A. Brice, London, England.—This detaching apparatus remains intact and locked as long as there is strain on the suspended rings, but is instantly released when the strain is taken off by the raising of the boat by the wave. It was described and illustrated on page 150, volume XXXV.

IMPROVED MACHINE FOR SAWING STAVES.

Benjamin H. Carching, Forest Grove, Oregon.—A band saw, or a saw of similar form in two parts, is fitted on an oscillating circular head, on each side of which is a saw table and feed carriage. The carriages are worked by weighted cords, and the saw tables have grooves in the under side for gagging the work to the saw, the guide being shifted from groove to groove as each stave is sawn off. A special advantage is that one part of the saw cuts while the other part is on the back stroke.

IMPROVED REVOLVING EARTH SCRAPER.

Benjamin Slusser, Sydney, Ohio.—This invention relates to certain improvements in revolving earth scrapers designed for general purposes of excavating and moving dirt; and it consists in the particular construction and arrangement of the scraper proper, made of a single sheet of steel bent so as to secure the best results in lightness of draft and perfection of filling, and provided with racking runners and an end board of peculiar arrangement, intended to improve the operation and increase the durability of the device. The invention also consists in the improved arrangement of the scraper with respect to its frame, the said scraper being pivoted therein upon double pivots, which are shifted from the front to the rear of the center of gravity, according to whether the load is to be transported or the scraper dumped by revolving.

IMPROVED NAIL PLATE FEEDER.

Rollin Van Amburgh, Wetmore, Kan.—The novel points of this feeder rest in the construction and arrangement of the devices attached to the barrel for feeding the nail plate to the knife, and in the means for reversing the barrel before applying its tapered mouth to the knife, which reversing movement is effected through the instrumentality of a band, and a reciprocating block moving on a spirally flanged or auger-shaped shaft.

IMPROVED CAR COUPLING.

Samuel Hamer, Salt Lake City, Utah Ter.—This combines a buffer arrangement with the drawhead and coupling. It consists of a spring-acted drawhead, with interior separately movable drawbar, to which a coupling spring hook is pivoted. The drawhead has a top shoulder that comes in contact with an auxiliary spring bolt, and acts as a buffer head.

IMPROVED HAY ELEVATOR AND CARRIER.

Joshua Anderson, Short Creek, Ohio.—This invention consists in the construction of the carriage and its arrangement to the track or way upon which it runs, the same being so constructed and arranged that the elevation of the load of hay in the fork trips the carriage and allows it to move upon the ways, and the load is held in its position near the carriage by a retaining device independently of the draft rope, so that it cannot sway to the floor again when the carriage is set free.

IMPROVED ANVIL.

James Jenkins, Cortez, Nevada.—This inventor has devised a means of repairing old and worn-out anvils cheaply, and thereby economizing metal, now lost when the face is worn down so as to be unfit for further use. It consists of a steel face and swage block, secured on the top of the anvil by a metal strap, screwed detachably to its sides, and fitted down the sides and under the bottom of the anvil, to which it is fastened. Keys are fitted between the block and the hollow face of the anvil, to support it firmly. The connection of the attaching strap to the sides of the block is such that the block can be reversed to use one side for the anvil face, and the other side for the swage block.

IMPROVED RESAWING MACHINE.

Thompson M. Newman, Gallatin, Tenn.—In this device, a rotary saw on a vertical arbor is arranged between two tables which are supported on screws so that they can be shifted up and down to vary the thickness of the stuff. They may also be inclined to the saw for sawing bevels, and have feed rollers geared by countershafts and belts, with the main horizontal driving shaft mounted in the lower part of the frame and turning the saw arbor by bevel gears.

NEW MISCELLANEOUS INVENTIONS.**IMPROVED MACHINE FOR CURLING FEATHERS.**

Johann Hawlowetz, New York city.—This consists of a revolving curler, in connection with an apron running over a driving roller, an adjustable stretching, and a swinging and spring-acted roller.

IMPROVED HEEL EVENER FOR BOOTS AND SHOES.

Abram Dilley, Drakestown, and John L. Larrison, Schooley's Mountain, N. J., said Larrison assignor to said Dilley.—As an improved heel evener for shoes and boots, that may be readily set to keep the heel level for any tread of the foot, the inventor provides two wedge-shaped rubber plates, that are applied by a center pivot to the insole and heel, and adjusted by upward projecting side lugs at their thickest part.

IMPROVEMENT IN PURIFYING IRON AND MAKING STEEL.

John L. Randall, Albany, N. Y., assignor to himself and Stephen Munson, same place.—This consists in treating molten cast iron, while in a receiver, with pulverized titanite or equivalent iron ore, potassic ferrocyanide, and potassic nitrate. The process allows of using old as well as new material, utilizing refuse metal the vitality of which has been nearly destroyed, restoring it to a high standard of excellence. By the said combination of materials also a superior and uniform grade of metal, suitable for extra fine castings, is produced, which may serve as a substitute for steel.

IMPROVED COMPOSITION FOR ARTIFICIAL MARBLE.

Louis De Planque, New York city, assignor to himself and Francis Strom, same place.—The composition consists of plaster of Paris dissolved in whey, under admixture of starch, glue, and sulphate of zinc. The mass is cast and pressed into molds, in which it remains a few hours until completely hardened. It is taken out of the molds when hard and polished. Any imitation of marble or other stone may thus be produced.

IMPROVED SHOW CARD FOR BUTTONS AND LIKE ARTICLES.

Charles A. Righter, New York city.—The buttons are attached to small cards, each card holding one dozen buttons. The cards have pointed ends which slip into slits in the large supporting card.

NEW HOUSEHOLD INVENTIONS.**IMPROVED MOSQUITO NET FRAME.**

Edward S. Lathrop and Louis Salvaterre, Savannah, Ga.—This mosquito net frame is designed to be applied to a bed or crib, and adapted to be extended with a mosquito netting canopy, which it carries across the bed to protect the occupants. It may also be readily drawn back by the occupants while in bed. It consists mainly of a pair of lazy tongs, one on each side of the bed, and so combined with a supporting standard, attached to the bedstead and the mosquito netting, that the latter may be readily extended across and enclose the upper portion of the bed, or be drawn to one end of the bed and out of the way.

IMPROVED WINDOW MIRROR.

Carl A. Demling, New York city, assignor to Anthony Demling, same place.—This is an improved reflecting mirror for the windows of buildings, by which the street in both directions and the door of the house may be observed by a person sitting at the window without the necessity of leaning out. It consists in connecting window mirrors to a sliding sleeve by a ball and socket joint, so as to make them adjustable in any desired direction.

IMPROVED BOSOM-IRONING BOARD.

Luther A. Van Kuren, Binghamton, N. Y.—In this device, the bosom is, by means of a swinging bar, readily stretched to the required degree of tension, and tightly held for being ironed until released by the raising of the bar.

NEW WOODWORKING AND HOUSE AND CARRIAGE BUILDING INVENTIONS.**IMPROVED WAGON END GATE.**

Zaccheus C. Wilson, Nokomis, Ill.—The object here is to furnish end gates for wagon bodies, so constructed, for convenience in dumping grain, that they may be opened and put out of the way without being detached from the said bodies, and in such a way as to leave the open ends wholly unobstructed. When closed they are firmly held in place, so that they cannot be pressed open by the load.

NEW AGRICULTURAL INVENTIONS.**IMPROVED SEED PLANTER.**

William F. Finney, East Castle Rock, Minn.—This machine, for planting corn, beans, sorghum, broom corn, and other seeds, is so constructed that it may be readily arranged to plant the seeds at any desired depth, that the plows may be easily raised from the ground, and so that the operating mechanism may be readily thrown into and out of gear with the driving wheel.

IMPROVED COTTON AND CORN PLANTER AND FERTILIZER DISTRIBUTOR.

William Scott, Fredericksburg, Va.—The invention consists in attaching two or more adjustable hoppers to a main shaft composed of two opposite equal arms, connected and made extensible by a central sleeve provided with a slot and clamp screw. Said main shaft has its bearings in vibrating side bars, pivoting at their front ends on the inner surfaces of the side bars of the main frame of the machine, and their free rear ends controlled by limiting pins fixed to said main frame, which is extensible longitudinally, and provided with the usual shovels, coverers, handles, and marker.

IMPROVED STRAW CUTTER.

Amasa Heverly, New Albany, Pa., assignor to himself and Philo Mings, of same place.—In this cutter the knives are made with convex edges, and are attached to a bevel-toothed wheel running against the mouth of the cutter box. Springs are attached to the inside of the cutter box at a suitable distance back of the cutters, and converging toward, and terminating a little in advance of, the cutters, to open and close on the material being cut according to its volume, and to confine it mostly at the middle of the range of the cutters. Through this arrangement it is claimed that the machine works better and easier than when the box is open across the whole breadth, while the stalks are free to be urged away to the outer portion of the cutters.

IMPROVED COMBINATION AGRICULTURAL TOOL.

Maynard Reynolds, Manchester Depot, Vt.—This is an improved shank, so constructed as to receive and securely hold a hoe, a weeding hoe, a potato hook, and a rake, in such a way that the said tools may be attached and detached by simply tightening and loosening a screw. A hoe, a narrow or weeding hoe, a potato hook, and a rake are designed to be made and sold with the handle. By this construction, by simply loosening a hand screw, either of the tools can be detached, and another inserted in its place, so that the farmer or gardener need buy but one handle or shank for a set of tools.

IMPROVED DEVICE FOR PICKING COTTON.

Richard A. Cutliff, Shreveport, La.—The process of picking cotton by hand is slow, tedious, and expensive, and machines for the purpose have failed to come into extensive use, first on account of their cost, and secondly their imperfect operation. The patentee has therefore devised a cheap but efficient means for facilitating hand picking, and the same consists of gloves or other hand coverings, provided with fangs, hooks, or claws, by which the cotton may be rapidly removed from the bolls. To free the cotton from the fangs or claws, a brush is provided, the same being attached to the body of the picker, in a convenient position to allow the gloved hands to be passed across and in contact with it. The cotton, thus removed from the fangs by the brush, rolls off and falls into a bag or basket, which is also strapped to the body of the picker.

(24) W. H. asks: Would it make any difference in the speed of 2 rowboats 18 feet long, one having a straight cutwater and the other having a cutwater inclining 4 inches in 18, this being the height of the boats, other things being equal? A. We scarcely think there would be any appreciable difference.

(25) J. F. N. asks: How can I remove the scale from sheet steel? A. With an emery wheel.

(26) D. R. W. says: We are obliged to use water from a well for watering plants. It forms an incrustation upon the earth and the flower pots, which, we presume, is alkali. Can you recommend anything which we can put into the water to neutralize the alkali? A. It is probably a lime salt. Try the addition of a little clean lime water, allow to stand a short time undisturbed, then pour the water off from the sediment.

(27) H. H. S. says, in reply to G. M. F., who asked if plaster of Paris were suitable for porous cells: Some two years ago I made several cells of Daniell's battery, using plaster porous cups, and found them to work very successfully. These cells were about the cheapest I ever saw. A. If the plaster cells are porous, they will answer instead of porous clay cells.

(28) H. J. says: Some time ago I saw an article in your paper recommending coffee as a disinfectant. It would be very expensive, and I have for years been using coffee grounds after the coffee has been extracted. I dry them and keep them for use. I simply sprinkle them over a hot stove or shovel of coals in the sick room. They would be good for emigrant vessels or hospitals, and might be used to great advantage in the yellow fever districts at present.

MINERALS, ETC.—Specimens have been received from the following correspondents, and examined, with the results stated:

H. S. S.—It contains no silver.—C. H. C.—It is decomposed mica.—C. P.—It is black oxide of manganese.—J. B. H.—It is carbonate of copper with shale.—W. S.—Both are sulphides of iron, No. 1 being pyrite, No. 2 marcasite.

COMMUNICATIONS RECEIVED.

The Editor of the SCIENTIFIC AMERICAN acknowledges, with much pleasure, the receipt of original papers and contributions upon the following subjects:

- On Aerostation. By J. J. R.
On Celestial Dynamics. By J. W. H.
On Mental Telegraphy. By J. L. M.
On Trisecting an Angle. By P. H. F.
Also inquiries and answers from the following:
F. P.—H. H. L.—V.—R. D.—W. C. K.—N. B. P.—W. L.—W. T.—R. K.—J. C. W.

HINTS TO CORRESPONDENTS.

Correspondents whose inquiries fail to appear should repeat them. If not then published, they may conclude that, for good reasons, the Editor declines them. The address of the writer should always be given.

Enquiries relating to patents, or to the patentability of inventions, assignments, etc., will not be published here. All such questions, when initials only are given, are thrown into the waste basket, as it would fill half of our paper to print them all; but we generally take pleasure in answering briefly by mail, if the writer's address is given.

Hundreds of inquiries analogous to the following are sent? "Who sells the best dies and taps for screw-cutting work? Who makes the best gas apparatus for domestic use? Who sells Centennial bronze medals? Who makes the improved zinc white, described on p. 323, vol. 35? Who makes the best incubators? Who sells the best ice machine?" All such personal inquiries are printed, as will be observed, in the column of "Business and Personal," which is specially set apart for that purpose, subject to the charge mentioned at the head of that column. Almost any desired information can in this way be expeditiously obtained.

[OFFICIAL.]

INDEX OF INVENTIONS

FOR WHICH Letters Patent of the United States were Granted in the Week Ending

October 3, 1876,

AND EACH BEARING THAT DATE.

[Those marked (r) are reissued patents.]

A complete copy of any patent in the annexed list, including both the specifications and drawings, will be furnished from this office for one dollar. In ordering, please state the number and date of the patent desired, and remit to Munn & Co., 37 Park Row, New York city.

Table listing various inventions such as Animal trap, Axle boxes, Bag fastener, Bale tie, Bale tie, Barbed fence wire, Barbed fence wire, Barbed fence wire, Barometer, Bed spring, Blackboard rubber, Blast furnace, Blower, Book binding, Boot soles, Boots, Boots, Bottle stopper, Bran-scraping machine, etc.

Main table listing inventions and their patent numbers, including items like Brick kiln, Bristles, Buckle, Bung cutter, Bung machine, Butter worker, Can, Can, Cane and stool, Capstan, Car axle box, Car coupling, Car coupling, Car roof, Car roof, Car spring, Car wheel, Carriage step, Cartridge-feeding device, Cartridge shells, Case for bottles, Chamber bucket, Chandeller, Check rower, Chimney top, Churn, Churn, Churn, Cigar pipe, Cigarette package, Clothes wringer, Coal, Cooling animal charcoal, Corn planter, Corn planter, Cornet, Cotton press, Cotton scraper, Cow milk, Cultivator, Currycomb, Die for press dyeing, Distilling oil, Door check, Door check, Door check, Dumping car, Dumping wagon, Dust guard, Dynamo-electric machine, Earthaugers, Easy chair, Electric coupling, Electric pile, Electro-magnetic governor, Evaporating liquids, Extension chandelier, Eyeglass, Fan, Fan, Feed water heater, Fence, Fire bricks, Flower stand, Fly trap, Folding chair, Food, Forging horseshoe nails, Fruit picker, Fulling mill, Furnace, Furnace, Furniture spring, Furniture spring, Game apparatus, Gas regulator, Gate, Governor, Grain door, Hand corn planter, Hand power for vehicles, Harness saddle, Harness saddle, Harrow and land roller, Harvester, Hat frames, Hat-pouncing machine, Hay and cotton press, Hay and grain elevator, Hay loader, Heating stove, Hinge, Hoe, Holdback, Hot air furnace, Hydrant, Hydraulic jack, Ingot mold, Ironing and polishing board, Ironing apparatus, Ironing board, Lamp, Lamps to instruments, Lathe attachment, Leather-skiving machine, Loom stop motion, Lubricating car axle, Mail bag catch, Match box, Match machine, Microscope, Middlings separator, Molding tobacco pipes, Mortising chisel, Mower, Mowing machine, Needle bar and cylinder, Netting, Nut lock, Ore washer and separator, Ornamenting metal, Paper-cutting machine, Parlor skate, Patterns, Pigeon hole for papers, Pin rack, Pipe cutter, Pipe for hot air furnaces, Pipe vice, Pitman for harvesters, Plow, A. Schuetz, Pocket book lock, Polishing machine, Pontoon for raising vessels, Potatodigger, Pump, Pump, Railroad rail joint, Railroad switch, Railway tie, Razorback, Regulator, Relief for air compressors, Rivet-heading machine, Rocking chair, Roll for welding tubing, Rolling band iron, Rolling horseshoe nails, Rolling blank nut bars, Sack filler and packer, Sadrion, Sadrion grinding machine, Safety pocket, Sash balance, Sash fastener, Saw bench, Sawing machine, Sawing machine, Scale beam, Scoop, Scroll saw, Sealing bottles, Sectional steam generator, Seed cotton gin feeder, Sewing machine stop, Sewing machine feed, Sewing thimble, Shade holder for lamps, Shafting, turning, Ships' rigging, Shirt, S. Gutmann, Shirt, C. C. & D. W. Noyes, Shirt and drawers, Show case for spool silk, Sign, A. W. Billings, Singletree, Spinning ring fastening, Spirit level, Spokes, trimming tenons, Spring air pistol, Stalk cutter, Star braid, Steam boiler scale remover, Steam generator, Steam heater, Steam lubricator, Step and hub band, Stone compound, Stone, dressing, Stop valve, Stop watch, Street lamp, Studs, winding spiral, Stump extractor, Tan bark, Thill coupling, Thill coupling, Osborne & Alexander, Three horse evener, Time and combination lock, Toy carrier, Toy money box, Trace fastener, Trackclearer, Trundle hoop handle, Trunk, T. R. Dunham, Truss, Turbine water wheel, Umbrella, Umbrellas, Upright pianoforte action, Ventilating mines, Ventilation, system of, Vignetting printing frame, Wagon brake lever, Wagon brake, Wagon jack, Washing machine, Watch chain, Water closet tank, Water cooler, Water elevator, Weather strip, Wheel plow, Whiffletree hook, Whip, Windmill, Wind wheel, Window bead fastener, Window screen, Wire fence barb, Wood-planing machine, Wood-planing machine, Wood pulp engine, etc.

DESIGNS PATENTED.

Table listing patented designs such as 9,506.—BAS RELIEF, 9,507 to 9,510.—CARPETS, 9,511 to 9,534.—CARPETS, 9,535.—CANDY BOX, 9,536 to 9,551.—CARPETS, 9,552 to 9,557.—CARPETS, 9,558 to 9,560.—CARPETS, 9,561 and 9,562.—CARPETS, 9,563 to 9,566.—CARPETS, 9,567 to 9,571.—CARPETS, 9,572.—CIGAR BOX, 9,573.—HINGES, 9,574.—CAMELS, 9,575.—STOVES, 9,576.—BRACELETS, 9,577 and 9,578.—DECORATING TIN, 9,579.—BRACELETS, etc.

[A copy of any one of the above patents may be had by remitting one dollar to MUNN & Co., 37 Park Row, New York city.]

SCHEDULE OF PATENT FEES.

Table listing patent fees: On each caveat \$10, On each Trade mark \$25, On filing each application for a Patent (17 years) \$15, On issuing each original Patent \$20, On appeal to Examiners-in-Chief \$10, On appeal to Commissioner of Patents \$20, On application for Reissue \$30, On filing a Disclaimer \$10, On an application for Design (3 1/2 years) \$10, On application for Design (7 years) \$15, On application for Design (14 years) \$30.

THE VALIDITY OF PATENTS.

We recommend to every person who is about to purchase a patent, or about to commence the manufacture of any article under a license, to have the patent carefully examined by a competent party, and to have a research made in the Patent Office to see what the condition of the art was when the patent was issued.

He should also see that the claims are so worded as to cover all the inventor was entitled to when his patent was issued; and it is still more essential that he be informed whether it is an infringement upon some other existing patent. Parties desiring to have such searches made can have them done through the Scientific American Patent Agency, by giving the date of the patent and stating the nature of the information desired. For further information, address MUNN & CO., 37 PARK ROW, New York.

Advertisements.

Inside Page, each insertion --- 75 cents a line. Back Page, each insertion --- \$1.00 a line. Engravings may head advertisements at the same rate per line, by measurement, as the letter press. Advertisements must be received at publication office as early as Friday morning to appear in next issue.

EMPLOYMENT.

ANY PERSON of ordinary intelligence can earn a living by canvassing for The Illustrated Weekly. Experience is not necessary—the only requisite being, as in all successful business, industry and energy. Send for particulars. Address CHAS. CLUCAS & CO., 14 Warren St., N. Y.

A GENTLEMAN out of business, having about \$50,000 to invest, wishes to associate himself with an established concern where from \$10,000 to \$50,000 increased capital could be advantageously employed. Address CAPITAL, Box 235, Boston, Mass.

Advertisement for Hyatt & Co's Varnishes, featuring an image of a product can and text describing the quality and variety of their varnishes.

Send for Circular and Descriptive Price List.

"LEHIGH EMERY WHEELS are in every way satisfactory, and for our purposes answer better than any others we have had." BARNES & Co., Syracuse, N. Y., Mowing Knives, etc. L. V. EMERY WHEEL CO., Weissport, Pa.

Danbury Drill Chucks, New—1876—Pattern.

GREATLY IMPROVED—ALL CAST STEEL. PRICE REDUCED TO \$8.00. Sold by all dealers in Mechanic's Tools. THE HULL & BELDEN CO., MANUFACTURERS, Danbury, Conn.

SECRETARY WANTED—TO MANAGE THE WATER-TOWN STEAM ENGINE COMPANY, at Water-town, N. Y. Address Co., giving business, experience, history, references, and salary expected. Oct. 20, 1876.

SETS OF DRAWING INSTRUMENTS 75 to \$100. Drawing Materials of all kinds. Levels, Compasses, Tape Measures, Aneroid Barometer from 1 1/2 inches to 6 inches in diameter. Telescopes from \$50 to \$250 each. Spy Glasses from \$3 to \$25 each. Microscopes from \$3 to \$100. Priced and Illustrated Catalogues, Part 1st, 84 pages, Mathematical, Catalogues, Part 2d, 120 pages, Optical Instruments. Sent on application.

JAMES W. QUEEN & CO., Opticians, 924 Chestnut St., Philadelphia, Pa.

J. M. CARPENTER MANUFACTURER OF FIRST CLASS TAPS AND DIES, Pawtucket, R. I.

IRON PLANING MACHINES A SPECIALTY. C. WHITCOMB & CO., M'rs, Worcester, Mass.

BIG PAY to sell our RUBBER PRINTING STAMPS. Terms free. TAYLOR & CO., Cleveland, O.

\$200 a month. Outfit worth \$1 free to agents. EXCELSIOR M'FG CO., 151 Mich. Av., Chicago.

IMPROVED PAPER BOX MAKER'S PASTING MACHINE. WM. DRAPEAU, Philadelphia, Pa.

Advertisement for DO YOUR OWN PRINTING FAVORITE Self-ink Press #16, featuring an image of the press and text describing its features and price.

Todd & Rafferty Machine Co.

MANUFACTURERS OF The celebrated Greene Variable Cut-Off, Lowe's Patent Tubular and Flue Boilers, Plain Slide Valve Stationary, Hoisting, and Portable Engines. Boilers of all kinds. Steam Pumps, Mill Gearing, Shafting, &c., Silk, Tow Oarum, Bagging, Rope, Flax, and Hemp Machinery. Agents for the New Haven Manufacturing Co.'s Machine Tools, for Judson's Governors and Stop Valves, Sturtevant Blowers, and Differential Pulley-Blocks. WORKS, PATTERSON, NEW JERSEY.

ELECTRIC BELLS, \$3.50 TO \$6.—AMATEUR Telegraph Outfits, \$4. Sent C. O. D., with privilege of examining. Send stamp for circulars. ROBINSON & DAY, Pittsfield, Mass.

TO RAILROAD MANAGERS & CAR BUILDERS—Complete Ventilation for railroad cars, street cars, and omnibuses, scientifically correct in principle, and mechanically very simple. Send for circular. Half interest in the patent for sale. C. G. VAN PAPPELENDAM, Charleston, Lee Co., Iowa.

WANTED—Salesmen on Salary only. \$85.00 per month, and all traveling expenses, to sell goods of our manufacturer to dealers in No. 100 PEARL. Address NOVELTY M'FG CO., Cincinnati, O.

ALLIS, BULLARD & CO., Limited, Dealers in first class 2nd hand Machinery & Machinery Supplies. Large Stock Tools in Store for immediate delivery. 14 Dey Street, New York.

IMPORTANT FOR ALL CORPORATIONS AND MAN'G CONCERNS.—Buerk's Watchman's Time Detector, capable of accurately controlling the motion of a watchman or patrolman at the different stations of his beat. Send for circular. J. E. BUERK, P. O. Box 979, Boston, Mass. N. B.—The suit against Imhaeuser & Co., of New York was decided in my favor, June 10, 1874. Proceedings have been commenced against Imhaeuser & Co. for selling, contrary to the order of the Court, Persons using clocks infringing on my Patent, will be dealt with according to law.

MANUFACTURERS AND PATENTEES having useful articles, suitable for the Hardware Trade, and desiring to manufacture and introduce the same, address P. A. RAFFERTY, CARE PRATT & CO., Buffalo, N. Y. Small samples may be sent, same to be returned if desired.

