

# SCIENTIFIC AMERICAN

A WEEKLY JOURNAL OF PRACTICAL INFORMATION, ART, SCIENCE, MECHANICS, CHEMISTRY, AND MANUFACTURES.

Vol. XXXV.--No. 14.  
[NEW SERIES.]

NEW YORK, SEPTEMBER 30, 1876.

\$3.20 per Annum  
[POSTAGE PREPAID.]

## THE CENTENNIAL EXPOSITION.--THE CENTER OF THE MAIN BUILDING.

The handsome engraving presented herewith gives a birdseye view of the central portion of the Main Building, from one of the galleries overlooking the music stand. From such a position, an excellent idea of the magnitude, proportions, and general appearance of the colossal structure may be formed; and the visitor will do well to ascend one

of the spiral staircases, and ascertain the extent of the building and the localities allotted to the different nations. Much of the finest art workmanship of this country and Europe is clustered round this center; and the jewelry, lace, and other fine manufactures attract large crowds of spectators to the highly ornamental stands over which are seen the renowned names of Tiffany, Starr and Marcus, Elkington & Co., and other cunning artificers in gold, silver, and precious

stones. To the left of the center are the spaces devoted to the British colonies, including the exhibits from India, Canada, Australia, and the West Indies. The *coup d'œil* shown in our picture (selected from the pages of the *Illustrated Christian Weekly*), taken in connection with the fact that this is only one of five principal buildings, and that there are besides over a hundred smaller ones, gives an excellent idea of the magnitude of the whole Exposition.

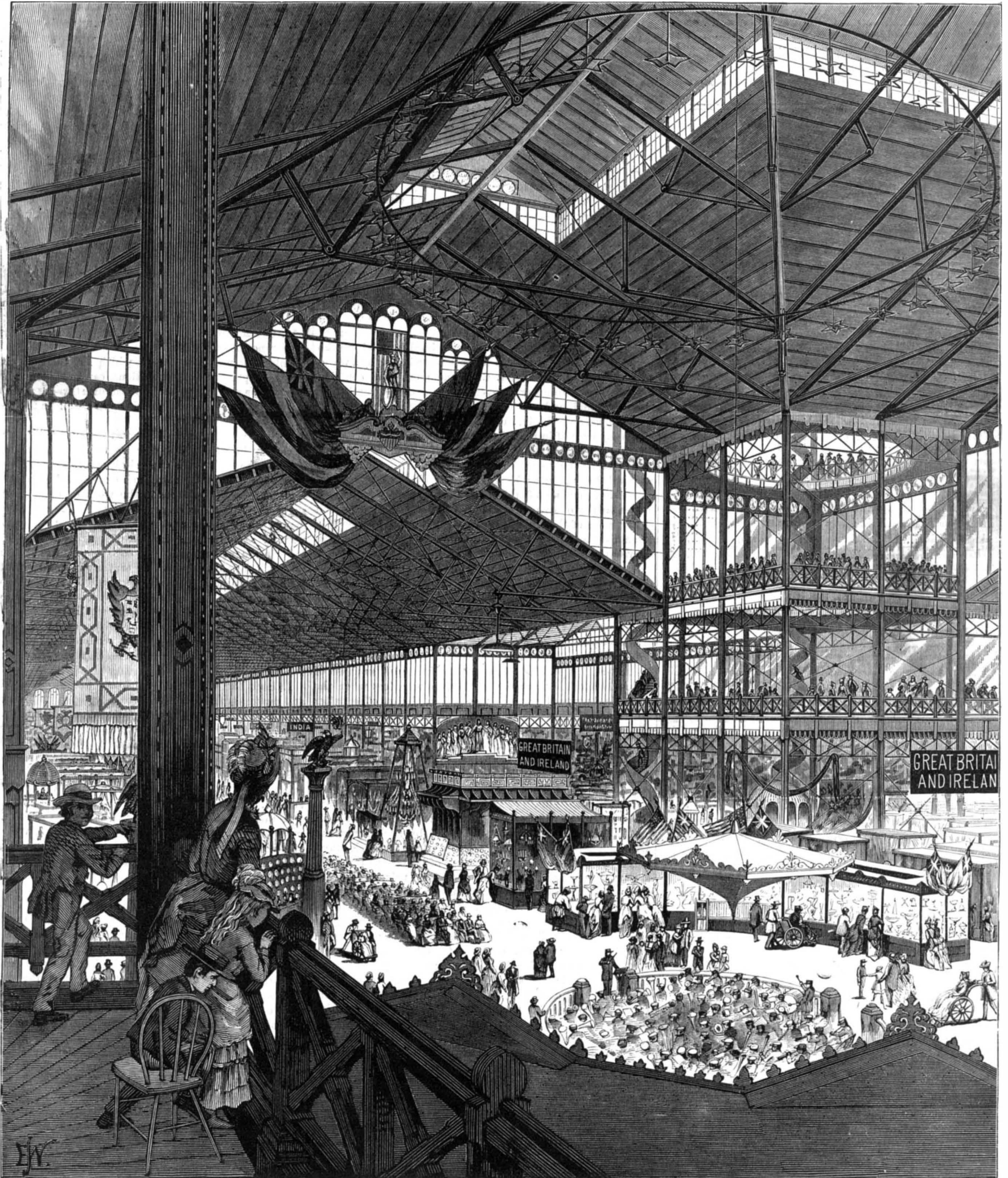

THE CENTENNIAL EXPOSITION.--VIEW FROM A GALLERY OF THE MAIN BUILDING.



Scientific American.

ESTABLISHED 1846.

MUNN & CO., Editors and Proprietors.

PUBLISHED WEEKLY AT NO. 87 PARK ROW, NEW YORK.

O. D. MUNN. A. E. BEACH.

TERMS FOR THE SCIENTIFIC AMERICAN.

One copy, one year, postage included.....\$3 20
One copy, six months, postage included..... 1 60

Club Rates.

Ten copies, one year, each \$2 70, postage included.....\$27 00
Over ten copies, same rate each, postage included..... 2 70

The postage is payable in advance by the publishers, and the subscriber then receives the paper free of charge.

NOTE.—Persons subscribing will please to give their full names, and Post Office and State address, plainly written. In case of changing residence state former address, as well as give the new one. No changes can be made unless the former address is given.

Scientific American Supplement.

A distinct paper from the SCIENTIFIC AMERICAN, but of the same size and published simultaneously with the regular edition.

TERMS

One year by mail.....\$5 00
SCIENTIFIC AMERICAN and SUPPLEMENT, to one address..... 7 00
Single Copies..... 10

The safest way to remit is by draft, postal order, or registered letter. Address MUNN & Co., 87 Park Row, N. Y.

Subscriptions received and single copies of either paper sold by all the news agents.

VOLUME XXXV., No. 14. [NEW SERIES.] Thirty-first Year.

NEW YORK, SATURDAY, SEPTEMBER 30 1876.

Contents.

(Illustrated articles are marked with an asterisk.)

Table listing various articles such as 'Air bubbles, etc.', 'Answers to correspondents', 'Asbestos and heat', etc., with corresponding page numbers.

THE SCIENTIFIC AMERICAN SUPPLEMENT.

Vol. II., No. 40.

For the Week ending September 30, 1876.

TABLE OF CONTENTS.

Table listing supplement contents such as 'THE INTERNATIONAL EXHIBITION OF 1876', 'ENGINEERING AND MECHANICS', 'TECHNOLOGY', etc.

The Scientific American Supplement

is a distinctive publication issued weekly; every number contains 16 octavo pages, with handsome cover, uniform in size with SCIENTIFIC AMERICAN...

All the numbers of the SUPPLEMENT from its commencement, January 1, 1876, can be supplied; subscriptions date with No. 1 unless otherwise ordered.

COMBINED RATES.—The SCIENTIFIC AMERICAN and SCIENTIFIC AMERICAN SUPPLEMENT will be sent together for one year, postage free to subscribers, on receipt of \$7.00.

TO SCIENTIFIC AMERICAN SUBSCRIBERS WHO WISH TO TAKE THE SUPPLEMENT.—A subscriber to the SCIENTIFIC AMERICAN may change at any time to the SUPPLEMENT, or may have both papers sent to him, by remitting to us the difference between the amount already paid for the SCIENTIFIC AMERICAN and the SUPPLEMENT prices above mentioned.

Remit by postal order. Address MUNN & CO., PUBLISHERS, 87 Park Row, New York.

Single copies of any desired number of the SUPPLEMENT sent to any address on receipt of 10 cents.

SURGERY VS. PHRENOLOGY.

For a long time, the popular pseudo-science of phrenology received little encouragement from the advancement of exact knowledge in the department of cerebral physiology and pathology. Indeed its pretensions were quite uniformly repudiated by the better class of students of the brain.

Their joy, however, is likely to be of short duration. That most acute observer and experimental investigator in the department of cerebro-spinal physiology and pathology, Dr. Brown-Séguard, is delivering a course of professional lectures in London, calculated not only to knock the last shadow of a prop out of the foundation of phrenology, but to compel a practical revolution in the views now generally accepted by physiologists and physicians with regard to the physiology and pathology of the brain.

His argument runs in this wise: When we witness a loss of function in connection with a lesion of a part of the brain, we are naturally led to suppose that the lost function has its seat in the part we find altered. So too, though in a less degree, we are disposed to admit that, if certain muscles contract involuntarily when a certain part of the brain is irritated, the part thus irritated contains either the nervous center or the conductors usually employed by the will in moving those muscles.

But such reasoning is erroneous, and the conclusions thus arrived at are essentially wrong: as wrong as it would be to suppose the central power of laughter to reside in the sole of the foot, because laughter results from the tickling of that part; or to infer that the seat of intelligence is in the intestinal mucous membrane, because its irritation by a worm may cause insanity; or that the same membrane contains the centers for voluntary movements and the perception of tactual, visual, and auditory sensations, because paralysis, convulsions, anæsthesia, loss of sight, deafness, etc., appear in consequence of intestinal irritation.

In the present state of knowledge of physiology, no one would admit the correction of such conclusions: but to Dr. Séguard they are not a bit further from the truth than the conclusion that the left third frontal convolution is the seat of the faculty of expressing ideas by speech, because when that portion of the brain is diseased the faculty of speech is often disordered or lost: or that the upper parts of the two convolutions bordering on the scissure of Rolando on one side are centers for the voluntary movement of the two limbs on the other side, because these limbs will sometimes be paralyzed when there is disease in those parts.

The fault with all such reasoning lies in a failure to distinguish between the effects of two possible unlike causes—irritation extending to other parts, and loss of function in the part disabled. For example, when Majendie observed that the senses of sight, hearing, and smell, as well as those of taste and touch, on one side of the face were lost when the trigeminal nerve of that side was divided, he and others after him inferred that the real nerve of those senses was the trigeminal. But subsequent experiments and observations have shown the observed effect to be due, not to a cessation of the function of that nerve, but to irritation causing an arrest of the activity of all the special sensorial nerves.

Similarly at fault are the conclusions that have been drawn from the effects of irritation of parts of the cortical substance of the brain by galvanism or disease in animals and in men. The movements indicated by such irritations arise, not because the psycho-motor centers for such movements are there located, but because of irritations transmitted to other parts of the brain. Proofs of this position Dr. Séguard draws from a wide range of clinical and experimental evidence of two sorts, the first showing that the alleged functional centers can be destroyed without destroying the function attributed to them; the second sort showing the complete absence of uniformity in the effects of local irritations. The same lesion in the same place may be followed either by an immediate effect, or by effects of the most widely varying character, when due to irritation: when due to the loss of special function, the effects of a lesion must be always present and invariably the same. Accordingly, no special function can be admitted to belong to a part of the brain if there is a single known case of a persistence of the supposed function when the part, if considered as a conductor, has been cut across, or, if looked upon as a central organ, has been entirely destroyed.

For instance, Flourens thought he had found the focus of life, the only origin of the supposed vital force, in the medulla oblongata; for in all his experiments, any injury to this organ, however slight, was quickly followed by death. But Dr. Séguard succeeded in removing the medulla oblongata entirely from certain living animals, with no other

effect than the slow apparition of a lasting epilepsy. The theory that the function of life is localized in that organ consequently had to be abandoned: the sudden death, which occurs in almost all instances when the gray matter at the nib of the calamus is injured or taken away, being attributable rather to the effect produced, by the irritation of the neighboring parts, on other parts of the nervous centers and on the heart. The nervous center for respiratory movements has also been located in the medulla oblongata. But having been able to make a transverse section of that organ, below the level of the supposed respiratory center, without producing a stoppage of respiration, Dr. Séguard feels justified in concluding that it is not so restricted, and that, when respiration is stopped by the division of the medulla oblongata, the stoppage is owing to the arresting influence of irritation on the nerve cells above and below the section, not, as hitherto supposed, to the separation of the respiratory center from its bonds of union with the respiratory muscles.

Evidence, clinical and experimental, not less cogent than the foregoing, is presented in these lectures in curious abundance and variety, disproving the localization of any function in any special part of the brain, whether according to the scheme of phrenology or any other. The drift of the evidence is summed up in the following revolutionary propositions:

- 1. A lesion in one half of the brain may produce symptoms either on the opposite side or on the corresponding side.
2. A very small lesion, whatever be its seat, can produce most extensive and violent symptoms.
3. A lesion occupying the same extent on the two sides of the middle line of the brain may produce symptoms only or chiefly on one side of the body.
4. Symptoms may appear suddenly from a slowly and gradually developing lesion.
5. Symptoms may appear slowly from a suddenly produced lesion.
6. The greatest variety of symptoms may proceed from a lesion in the same part of the brain.
7. The most various parts of the brain can give rise to the same symptoms.
8. Permanent lesions may produce symptoms by attacks, just as they produce epileptiform seizures.
9. Symptoms may cease suddenly or rapidly notwithstanding the persistence of the lesion.
10. Symptoms of brain disease may appear from an irritation of visceral and other peripheral nerves.
11. Considerable lesions anywhere may exist without the appearance of symptoms.

Unless the numerous cases, which Dr. Séguard cites at length in proof of these assertions, can be shown to be mis-observed or misinterpreted, a radical overturning must ensue in our notions of cerebral physiology, as well as the final destruction of phrenology.

The learned lecturer does not rest with the destruction of current beliefs. He endeavors to harmonize the physiology of the brain with clinical observation, to make theory tally with fact, but in doing so his caution shows in striking contrast with his boldness in the work of demolition. He suggests: 1. That as regards localization of function, a great many facts lead to the view that the nerve cells endowed with the same function, instead of forming a cluster so as to be in the neighborhood of each other, are scattered in the brain, so that any part of that organ can be destroyed without a cessation of their function. It makes no difference whatever whether the distance between nerve cells employed in the same function is a small fraction of a millimeter or very much greater, as in either case their communication with each other must take place by conductors (nerve fibers), the length of which is unable to interfere with the function.

2. Each half of the brain is a complete brain originally, and possesses the aptitude to be developed as a center for the two sides of the body in volitional movement as well as in all the other cerebral functions. Still very few people develop very much, and perhaps nobody quite fully, the powers of the two brains: on the contrary, in most persons only one of these two primarily similar organs acquires great power for certain actions, and the other for other actions.

3. Communications between the body and the brain can be more or less fully accomplished by means of a very much smaller number of conductors than would be necessary according to any view like the well known clavier theory. As we know by clinical facts that any part of the medulla oblongata can be destroyed without paralysis, and that in some cases a very small portion of it has proved sufficient for the persistence of voluntary movements, it would seem that an order of the will may be transmitted as well by one nerve fiber as another, and that it is necessary to recognize the existence of faculties of a much higher order in the spinal cord than those which are admitted to exist there. Many facts and similar reasoning tend also to show that the nerve cells of the spinal cord possess, as regards sensibility, faculties of a much higher order than those which are now admitted.

In another connection, the lecturer asserts his belief that the experiments of Fritsch and Hitzig, Dr. Ferrier and Dr. Bochefontaine, in proving the sensitiveness of the convolutions of the brain to galvanic irritation—his own experiments showing the excitability of all parts of the brain by the application of heat to the convolutions, to the white substance of the cerebral lobes, and to the great masses of gray matter at the base of the brain—and the evidence supplied by thousands of cases of disease, prove that the brain is not to be considered as different from the peripheral parts of the ner-

vous system; and he promises to demonstrate that all the symptoms of brain disease—such as paralysis, anæsthesia, amaurosis, aphasia, insanity, convulsions, and the rest—are produced by the same mechanism, whether they arise from an irritation in any part of the trunk or limbs, or from an irritation in any part of the meninges or of the brain itself.

**AMERICAN AND ENGLISH RAILWAYS.**

A few months ago the London *Times* editorially instituted a comparison between English and American railways. It took the somewhat paradoxical ground that, as Scotland had the worst possible climate, and therefore educated the most perfect gardeners, and as France has the least material for the kitchen, and therefore turns out the most perfect cooks, so America, having the worst possible railroads, has the most perfect system of management, and the safest. An American editor suggested that under such circumstances the wise thing for the English to do would be to spoil a few of these railways, in order to bring their safety up to the American standard.

Recent accidents have brought out the correspondents of the *Times* on the same subject; and as there is a popular impression that everything in England is safer than in our own country, it may interest our readers to see what Englishmen say on the subject of railways, English and American. "Traveler," in a late number of the *Times*, starts out with the declaration that "English and American railways present at one point a marked and, to us Englishmen, a humiliating contrast." He then proceeds to show that, while Americans have established over running trains a control which is almost perfect, the English still maintain the rude and ineffective methods which were in use at the very dawn of railway traveling.

"When the driver of an English train sees danger before him, he shuts off steam. His fireman begins in haste to turn a lever. The guard, warned of impending peril, makes his way as quickly as possible to a similar lever at another part of the train. In ten to fifteen seconds, the combined efforts of fireman and guard have applied the brake to fourteen wheels, probably one fourth of the number on the train. Ordinarily the feeble action of our brakes is cut short by a shattering collision, and the death or injury of many of the passengers." Such is the English traveler's testimony as to his own country. Of the American roads, he says: "In presence of similar danger, the American driver touches slightly a little handle which stands up before him. In less than two seconds every wheel in the train is grasped by a powerful brake; and before the train has traversed a distance greater than one and a half times its own length, it is brought to a stand."

There is a slight inaccuracy in this statement. Car wheels are usually in groups of four or six, and the brake is applied to two wheels in each group. On the English roads the train is a string of small cars or carriages, and only a portion of these are provided with brakes. Our plan is more "democratic," but more safe; and if the non-exclusiveness of the American railway cars can be an objection, that difficulty is met by palace cars, in which an extra price is charged.

**THE FRICTION OF SLIDE VALVES ON THEIR SEATS.**

"Mechanic" writes:

"If we have a simple metallic plane, enclosed in a chest charged with steam, moving on a plane seat, without ports in either: Would any more power be required to move this valve than when the chest was not charged with steam pressure? If more power would be required, how much? And if a port were cut through the seat, leaving a portion of the same valve beneath, equal to the area of the port, exposed to the simple atmospheric pressure, how would the valve be affected in the matter of the power required to move it under these new conditions?"

And the same mail brings us a similar enquiry from N. D. S., another subscriber. In reply to these and other communications which we are continuously receiving upon the same subject, we would say as follows: The coefficient of friction for cast iron is 24, that is to say, if two cast iron surfaces are in positive contact, every 100 lbs., weight of the top one will require 24 lbs. to slide it upon the other. The weight of the top one is made up by the weight of the iron added to whatever amount of vacuum there may be between the two surfaces. Suppose for instance a slide valve is 10 inches by 5, and therefore contains 50 square inches of area, and that it weighs of itself 10 lbs.; if then it is surfaced truly, and beds upon an horizontal surface so as to exclude the air, it will be pressed to its seat, first by its own weight, and secondly by the atmospheric pressure of 15 lbs. per square inch, making a total of  $(50 \times 15) + 10 = 760$  lbs. If, however, the plate stood edgewise, as in the case of engines having the slide valve on the side instead of on the top of the cylinder, it would have the atmospheric pressure only pressing it to its seat, that is to say, in this case 750 lbs. If we consider the valve of an ordinary 16 inch cylinder engine to measure 8½ by 14 inches, and allow a pressure of 130 lbs. per inch in the steam chest, there would be, supposing the valve to bed perfectly to its seat, a pressure of 15,470 lbs. forcing the valve to its seat; and the whole pressure upon the piston being 26,442 lbs., the friction of the valve would entail a loss of about 58 per cent of the power of the engine.

It is to these considerations that are due the numerous efforts to produce valve-balancing devices. As a matter of fact, however, the pressure to the seat will be in precise proportion to the area of the valve in positive contact with the seat, and this is the point that sets all calculation at naught; since it is impracticable to ascertain, under ordinary circumstances, what amount or proportion of the valve

beds sufficiently to its seat to exclude the steam from between them. A writer in the *Railroad Gazette*, of July 28 last, says upon this subject:

"A valve may be made to bed sufficiently to be steamtight without being so perfect a fit as to induce undue pressure to its seat; and there is good reason to believe that, under ordinary conditions, a locomotive slide valve never fits so closely as to induce the pressure due to a flat, true, and smooth surface. Scrape a valve face to its seat as truly as we may, the steam fills the hollows of the scraper marks, and thus relieves the valve of a very large proportion of the pressure due to its area. It would appear that the scraper marks are soon worn down, and hence the valve then beds perfectly to its seat, and this undoubtedly would occur if the wear upon all parts of both the valve and the seat faces was at all times equal, and the conditions were constant; but such is not the case. The bridges between the cylinder ports wear a little the most, and wear hollow in their lengths, for the reason that the wearing surfaces, upon which the valve beds, standing at right angles to the top and bottom of the bridge, are greater and hence suffer less abrasion. Then again inequalities in the texture of the metal, and other causes, in themselves trivial, form in the aggregate the causes which operate to prevent the equal abrasion of the seat and valve face at all parts of the surfaces; and hence it is that, when a locomotive comes to be repaired, we find those faces worn considerably out of true, as might be expected, not only from the variation in the amount of contact on different parts of the surfaces, but also from the irregularity in the speed at which the valve travels while such contact is taking place."

Of more consequence than the above considerations, however, is the fact that the form of a slide valve is continually changing. During the process of the cooling of a casting after the metal is poured, the surfaces lose their temperature in advance of the internal metal, and their crystalline formation takes place more rapidly; those surfaces become rigid sooner than the inner metal, and therefore resist the strains produced in the cooling and crystalline formation of the latter. There is then upon the surface of all castings a tension which is relieved in precise proportion as those surfaces are cut away; hence as the edges and face of a valve are planed, a re-formation takes place, which throws the face out of true. This is remedied in surfacing the valve; but when the valve is placed under steam, the increase in its temperature induces a more complete re-formation: so that, surface a valve as true as we may, we find that it does not bed true to its seat when it is first placed under steam, nor indeed until it is worn down to that degree of practical truth obtainable under the conditions of its wear. If we now turn to the cylinder, we find that a large proportion of its surface area has, by the boring and planing, been relieved of its tension, inducing in it also a re-formation, first, during its manipulation, and secondly, when placed under steam; so that we may scrape up the valve and seat surfaces as truly as possible, but we cannot hope to make them fit sufficiently close to keep a vacuum between them when heated to the temperature due to the steam pressure. It would appear, however, that, after the re-formation had once completely taken place, the valve would wear to a close fit; but the pressure of the steam, and hence the temperature of both the cylinder and the valve, is continually changing, not only because of variations in the boiler pressure but also by reason of the action of the link motion in giving more or less steam to the cylinder. The irregularity of the shape of both the cylinder and the valve causes their expansion and contraction to vary under different temperatures, operating to alter the fit of the valve to its seat. The valve also, as it wears thinner, undergoes continuous change of form, so that it springs more from the pressure due to the steam.

From these considerations we cannot define the pressure of a valve to its seat further than by saying that it cannot be less under any circumstances than that of the area of the valve exhaust port multiplied by the pressure of the steam, because that amount of pressure cannot be balanced by any want of contact between the valve face and the seat. Of the amount of force necessary to move a valve under any given pressure to its seat, we can form no estimate, because that again depends upon the fit of the valve to its seat. If the faces permit of a film of steam beneath them, they will glide, one over the other, much more easily than if they are steamtight.

**AN OPPORTUNITY FOR INVENTORS.**

One of the most fruitful sources of discomfort and disease of the eyes is their use in a fluctuating light. Artists, whose professional success hinges on healthy vision, are very careful to have the studios face the north, for their own comfort in working quite as much as for the advantage of a uniform light for estimating the effect of their lines and colors. But all persons who work with their eyes cannot command a north light. The pupils in our schools, the readers in our libraries, the writers in offices, typesetters, and fine workmen in every department are forced to take such light as they can get, often with rapid changes from glare to gloom. No one need be told how exasperating such changes are, or how injurious they may become to eyes constantly taxed for nice perception. Particularly injurious are such sharp and sudden variations of light to the sick, more especially to the patients in ophthalmic wards.

The problem is to devise a system of inexpensive blinds, which shall automatically open and shut with the varying intensity of sunlight, so as to admit a uniform amount of light into our reading rooms, offices, workshops, hospitals, and so on. An ingenious person who is able to meet the

requirements of the case might make a good thing out of it for himself as well as for the public.

The motive power should be the sun, whose rays are to be admitted or excluded according to their force and brilliancy. The apparatus might be a system of lightly moving blinds worked by a thermo-electric current, generated by the action of the sun's rays on a thermopile. In such a case the motion of the blinds could be made directly proportional to the brightness of the sun, and the light admitted perfectly equalized. Or the immediate source of motion might be a battery of selenium bars, that metal being electrically sensitive to light.

These are merely suggestions which any experimenter can improve upon. The field is a new one

**Trial of a New Cofferdam.**

The coffer dam invented and patented by Mr. J. E. Walsh, of this city, and illustrated and described by us on page 287 of our volume XXXII, was submitted to a public trial on Tuesday, September 13. A large number of officials and engineers were present to witness the operations. The sides and ends of the structure (which is called the Centennial) enclose a water space of over 4,000 square feet, with solid timber walls, 15 feet wide, and built double, with the space between them divided into compartments. The walls are fitted with keels, so the dam, when it is lowered into the mud, rests steadily, the keels in the mud making a perfectly watertight joint all round.

When the valves in the walls were opened to admit water, the dam began to sink slowly and steadily; and when water level was reached and the valves closed, additional water was pumped in to sink her. When the weight of the structure and the water ballast brought her to rest on the bottom, the full power of the pumps was applied to empty the interior of water, and the bed of the stream was soon laid bare. Large numbers of fish were deprived of their element, and workmen descended into the mud to keep the foot valves of the pump clear. The water inside the dam was 23 feet deep when pumping commenced; and the dam sustained the pressure of this depth without any leakage being apparent. Commissioner Salem H. Wales, President of the Dock Commission, and many members of the engineering profession present expressed themselves as perfectly satisfied with the trial, and complimented Mr. Walsh on his invention, and on the substantial and efficient manner in which his ideas have been carried out in the coffer dam under trial.

**Tensile Strength of Cement.**

*La Compagnie du Gaz Parisien*, previous to constructing some large gasometers near Paris, experimented on the different materials to be used in their construction; among others, on the cement which was to be used for the vertical walls of the reservoirs (*cuves*), with the following results: The cement used was Portland cement of Pouilly in Burgundy. It was found that a brick of pure cement six weeks old, which had been kept in water during that time, broke under a tensile strain of 170 lbs. to the square inch (12 kilogrammes per square centimeter); that a brick six months old, which had also been kept under water, broke under a strain of 441 lbs. to the square inch (31 kilogrammes per square centimeter); that cement hardens more rapidly, when exposed to the sunlight and fresh air, than when affected by humidity; but that this is at the expense of the tenacity and impermeability of the product: hence masonry walls should be sprinkled regularly until the cement has set; that the degree of fineness has an effect on the setting of cement, and consequently upon its ultimate tenacity, for it is a rule that the tenacity is in inverse proportion to the rapidity of the setting; that a mortar made of two parts sand to one of cement broke under a strain of 277 lbs. to the square inch (19 kilogrammes per square centimeter), while a mortar of equal parts of sand and cement broke under a strain of 427 lbs. to the square inch (30 kilogrammes per square centimeter). The effect of sand upon the shrinkage was shown by the facts that pure cement was defaced by cracks a little more than a foot apart; when mixed with equal parts of sand, the cracks were little more than a yard apart; when three parts of sand to one of cement were used, there were no cracks at all: hence it was this mixture that was used in constructing the reservoirs.

**Fire near the Centennial Buildings.**

A fire recently broke out in Shantytown, as the Philadelphia papers call the wooden structures adjacent to the Centennial grounds. They are located on the broad avenue opposite the Main Building. These wooden structures were thickly clustered together near the gates; and before the fire could be got under control, \$80,000 worth of property was destroyed, including some twenty small hotels, restaurants, etc. The heat was sufficient to blister the paint on the gates of the Exposition grounds, and warm up the interior of the Main Building.

**The New Bergen Hill Tunnel Completed.**

The new Delaware, Lackawanna, and Western Railroad tunnel is completed, and will be ready for use as soon as the debris is removed, which will not be later than November 1. It is 4,270 feet long, has six shafts varying in depth from 75 to 90 feet, and cost \$1,000,000. The filling of the road bed from the eastern end to the river, across the meadows, where stone ballast has sunk to a depth of sixty feet before reaching a solid foundation, has been a source of great perplexity and expense, requiring much engineering skill



**THE VICTOR DRILL CHUCK.**

We illustrate herewith a new self-centering drill chuck, in which the clutches are flush with the face or front of the device, by which arrangement, it is claimed, the workman has less difficulty in adjusting the drills, and the said clutches are not liable to be broken under strain or through dropping the chuck. The invention embodies a new device for operating the levers which control the clutches, and there are various other advantages which will be noted as we progress.

The chuck head has a spindle whereby it is secured to the lathe mandrel, and also a small screw which gears into the female screw formed inside the chuck holder. A spindle on the head carries a cylindrical follower, as shown in the sectional view, Fig. 1, which is provided with three longitudinal slots having bottoms inclined as represented.

The rear ends of the levers which actuate the clutches enter the above mentioned slots, and at their fulcrums are enlarged and rounded, so that they there have spherical bearings which rest against adjustable set screws passing through the walls of the holder. The clutches each consist of a short metal cylinder having a broad longitudinal feather and beveled at the lower edges. These fit in a series of radial cylindrical chambers near the face of the holder, the latter being slotted in front of the cylinders to receive the feathers on the clutches, which come flush with the front of the chuck. The front ends of the levers fit into recesses of the clutches, the rear ends being provided with pivots to return the clutches or throw them out when the rear ends of the levers are released by the follower. To effect this, the recesses in the follower are grooved on the sides on a line parallel with the inclined bottom. Into these grooves the lever pivots enter, so that the levers are thrown back on the return motion of the follower.

The device holds from 0 to  $\frac{3}{8}$  inch drills, or will carry  $\frac{1}{2}$  by reducing the shank, as shown in Fig. 3. The drill being inserted between the clutches, the chuck head is then turned so as to advance the follower, when the inclined bottoms of the recesses force the rear ends of the levers apart, pressing the clutches together in their radial chamber toward their common center, causing them thus to grasp and hold the tool. When the latter is to be released the operation is reversed. The pivots and the grooves in the follower then act upon the levers, bringing them back to their original positions and moving the clutches away from the tool.

The exterior appearance of the chuck is shown in Fig. 2. Its construction, of steel throughout, is durable and strong, and the arrangement of the levers, as already explained, admits of its easy adjustment.

Patented by Geo. M. Pratt, June 1, 1875. For further particulars address the Victor Sewing Machine Company, Middletown, Conn.

**AUTOMATIC LEATHER SCOURER AND HIDE WORKER.**

The improved leather scourer and hide worker herewith illustrated is complete in itself, and is independent of buildings or extra framework. It can be put up on any ordinary strong floor, without bolting down or bracing, with safety to both machine and building. It is simple in construction, and its many movements are effected by direct and positive means. It is made wholly of metal, disposed so as to secure great strength, and is further protected by air cushions, which relieve it of thrusts and strains.

The machine can be set up at any angle with the line shaft, and belts may be attached at either end, from above or below. It requires comparatively little power to run it, from one to three horse being sufficient, according to the thickness of leather to be dressed. But little more space is occupied than that required

for a table alone, thus saving, it is claimed, fully seventy-five per cent of the room occupied by the old-fashioned scourer. The machine is universal in its movements; and it can be readily managed, being so far automatic that the strength of a man's finger will guide its movements. It is capable of the widest range of work, from the lightest to the heaviest; it will scour, set out, or gloss; it can be made to take a slow or quick stroke, a long or a short one, the stroke being effected by the epicycle and cam combined. Lastly, it is claimed that, through the efficiency of the ap-

then only in a downward direction. During the first week of its captivity we fed the kingfisher with six to twelve minnows and sticklebacks each day; we gave them to it head foremost, so that the fins might not stick in its throat; it always kept them in its bill for a short time, and then bolted them suddenly. When it began to take the minnows off our hands it always got them in its bill crosswise, where it held and shook them before swallowing them; from this time on, wards it ate every day about two dozen minnows and sticklebacks, and occasionally a young gudgeon. It had been in

our possession for a fortnight when we first saw it fishing for itself, but we believe it helped itself for two or three days before it was noticed doing so, because it was often not at all hungry when we went to give it a meal. While it was unable to feed itself we occasionally gave it dead fish, which it swallowed as readily as living ones; it always swallowed the latter without killing them, although it shook and squeezed them, and frequently made them bleed.

In the bath room where the kingfisher lives we keep a stock of minnows, etc., in a large earthenware basin; until lately we several times a day put some of them into a saucer, from which it took them, but now it fishes in the large basin. It is very interesting, and has given pleasure to many of our friends, to watch the kingfisher perched on the edge of the basin, intently looking down into the water until a minnow comes within its reach, when it darts at and seizes it with its bill, without wetting its feathers. "The castings or pellets cast up by the kingfisher vary considerably; some are pure white, and remind one of very fine crystals, and others are of different shades of drab or gray; they are composed, I believe, entirely of fish bones, and are about half an inch long, and oval; I believe they are cast up at different times of the day, and the average number produced is about one per day. I have not yet heard

the usual note of the adult bird uttered by this young kingfisher; it has a kind of whistling chirp, much less shrill and loud than the old bird's. Its plumage is as brilliant as that of the kingfisher at any age, but I do not know whether it is a male or female; I suspect it is a male from the length of its bill (one inch and three quarters to one inch and seven eighths), which probably is not yet fully grown. It is stated by Montagu that the bill of the male is two inches long; he does not give the length of the female's, but says it is not so long as that of the other sex."—*J. E. Palmer, in the Zoölogist.*

**Race Horse War Steamers.**

The *London Daily News* says: "Half a dozen steel corvettes, each 2,300 tons, are forthwith to be added to the navy: swift, well armed vessels, to serve as cruisers. For some time past steel has been regarded by shipwrights with a favorable eye, being tougher and altogether less liable to fracture than iron, and now the Admiralty has taken the bold step of concluding a contract for building six war ships of this material without delay. They are to be built on the Clyde, and to be ready for service, with their engines on board, within two years. These corvettes will not serve in any fleet along with big ironclads, but are designed especially for foreign service in China and the Pacific, as also for cruising in the vicinity of our colonies and foreign possessions.

They will be remarkably fleet sailers, and, it is anticipated, will be able to make twenty miles an hour without difficulty. Their armament is to consist of fourteen guns of different calibers.

"As their great speed will always enable them to show their sterns and prevent hostile craft from approaching, these steel corvettes should prove most useful additions to our navy; and it may safely be taken for granted that where they are likely to cruise there will be little chance of falling in with heavy ironclads, which are unable to trust themselves very far from land."

Fig. 1.

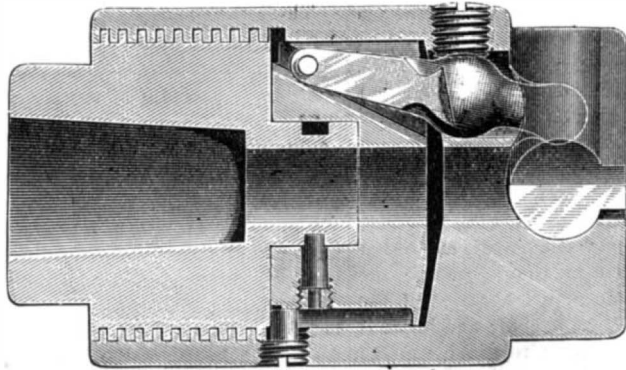
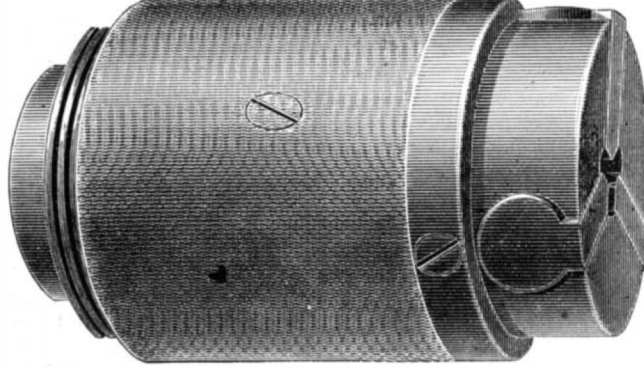

Fig. 2.

**THE VICTOR DRILL CHUCK.**

paratus, it will save its owner from fifty to seventy per cent of the cost of scouring and setting out.

Patented by F. A. Lockwood, of Fall River, Mass., July 26, 1876. Manufactured by S. C. Forsaith & Co., Manchester, N. H. W. E. Plummer, Boston, Mass., is sole agent for the Lockwood Leather Scouring Machine Association.

**Defects in the Human Eye.**

We have already called our readers' attention to Helmholtz discovery of several defects in the human eye; and from

Fig. 3.

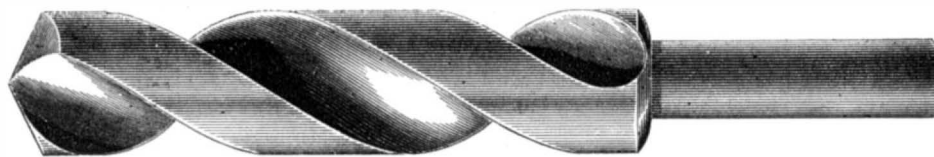

statements made at a recent meeting of the Physical Society, London, it appears that a kind of chromatic aberration must be added to the list. It was stated that to short-sighted persons the moon appears to have a blue fringe; and that, in using the spectroscope, different adjustments of the focusing glass are required for the two ends of the spectrum. Moreover, a black patch on a blue ground appears to have a fringed margin; but on a red ground, the edge of the black patch is sharply defined.

**History of a Young Kingfisher.**

As the kingfisher is not often kept in confinement, the following account may be of interest. It was one of five brought to us in a basket, on May 31, by a boy who had taken them from a nest in the bank of a small stream not more than three feet wide; they were fully fledged, and we think about three or four weeks old. We kept one and gave the others to the Zoölogical Garden, Dublin, thinking that they would be more likely to thrive there than with us, but unfortunately the four all died after being there four days. The one we kept was put into a cage, which was often placed out of doors in the daytime. After two or three days we began to allow it the use of a bath room for the greater part of the day, so that it might learn to fly, which it did at once. When brought to us it did not fly more than half a yard, and

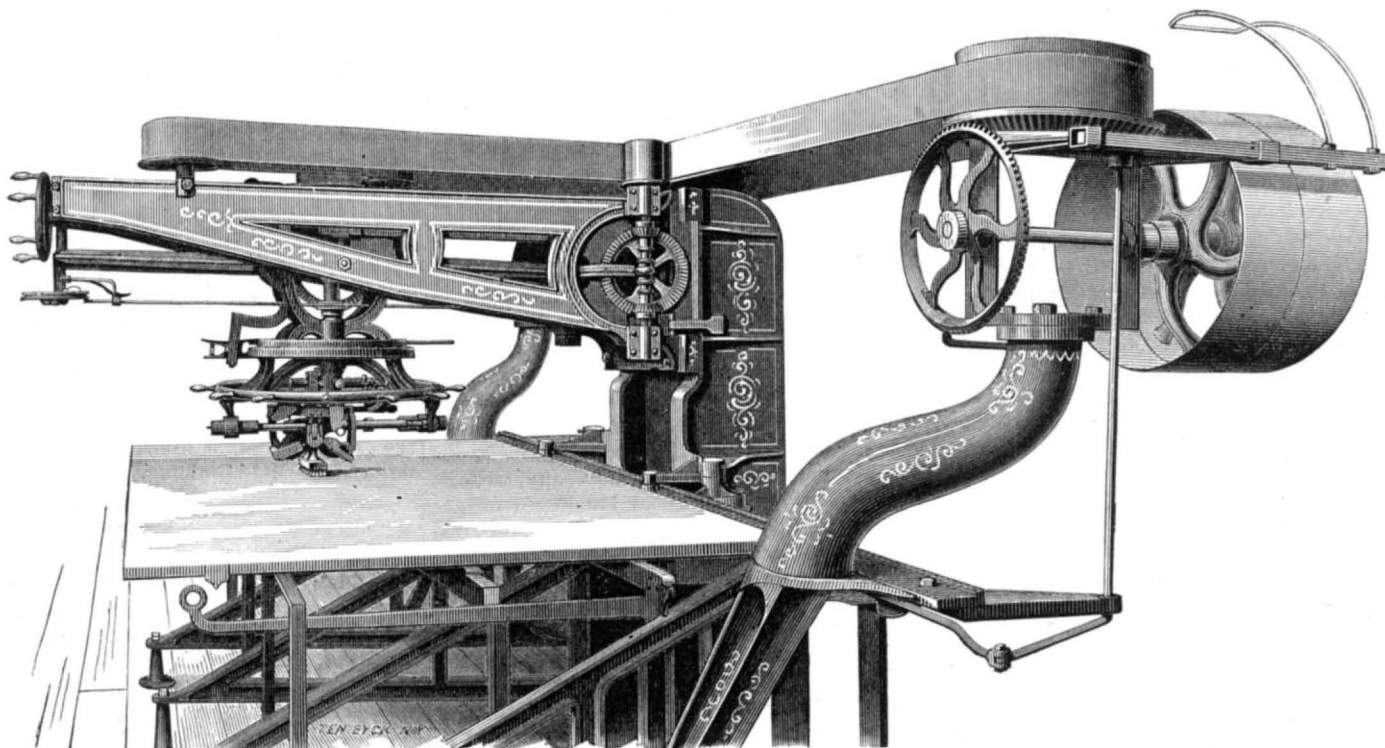
**LOCKWOOD'S AUTOMATIC LEATHER SCOURER AND HIDE WORKER.**



**IMPROVED COMPOUND STEAM PUMP.**

The special advantages claimed for the improved steam pump illustrated herewith are as follows: 1st. It has only two moving parts, except the pump valves, thereby reducing friction to a minimum. 2d. The steam, having performed its work in the high pressure space, is afterward expanded, thereby extracting all the power possible from it, and effecting a large saving in fuel. 3d. The high pressure and expansion are both carried on simultaneously throughout the entire stroke, thereby maintaining a more uniform aggregate piston pressure to the end of the stroke. 4th. It is simple, compact, durable, and portable, and can be used without expensive foundations.

The indicator diagram shown in Fig. 1 was taken from one of these compound cylinders, and a study of it will demonstrate the economy of such a pumping engine in comparison with pumps that must use a cylinder full of steam at each stroke. Attention may also be directed to the very short passage ways for live steam between the valve and the high pressure piston, thus insuring less waste of steam from steam passages than is usually the case.

In Figs. 2, 3, and 4 three sectional views of the machine are given. The elongated piston has two ends provided with packing, and has a cylindrical portion of a less diameter extending between the said ends, the said portion being fitted to work steamtight in a central partition in the cylinder. Two annular chambers are thus formed, into which steam is admitted to act upon the smaller areas of the piston ends; and it is afterward expanded into the spaces between the piston ends and the cylinder covers, to act upon the larger areas of the said piston. A double cylindrical valve regulates the movements of the steam, each half of it being formed with a passage to connect two ports, through which steam passes from the annular space to the space between the piston and the cylinder head, and also with a passage which connects the larger steam space with the exhaust passage. Steam is admitted into a space between the two parts of this

Fig. 3.

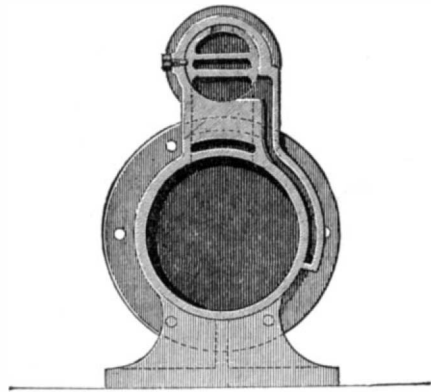
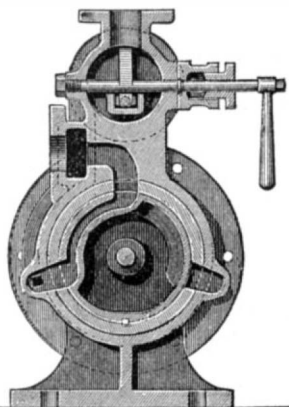

Fig. 4.



valve, and finds its way by suitable openings into the end spaces between the said valve ends and valve box covers; the said end spaces are connected by passages with ports formed in the aforementioned partition; and as the piston moves

to and fro, passages formed in the said piston establish a communication between the said ports and a port leading into the exhaust passage, thus relieving the valve from pressure on one end and causing it to be quickly pushed in that direction by the steam at the opposite end; the parts are all so arranged as to provide effectually for sufficient steam

Fig. 1.

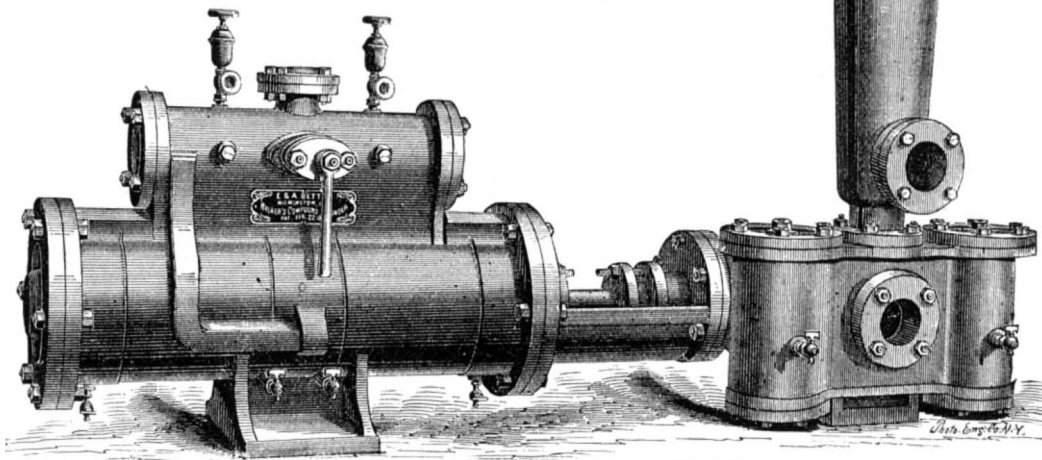
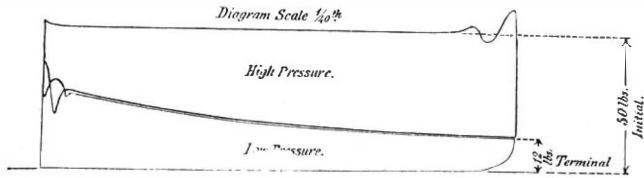
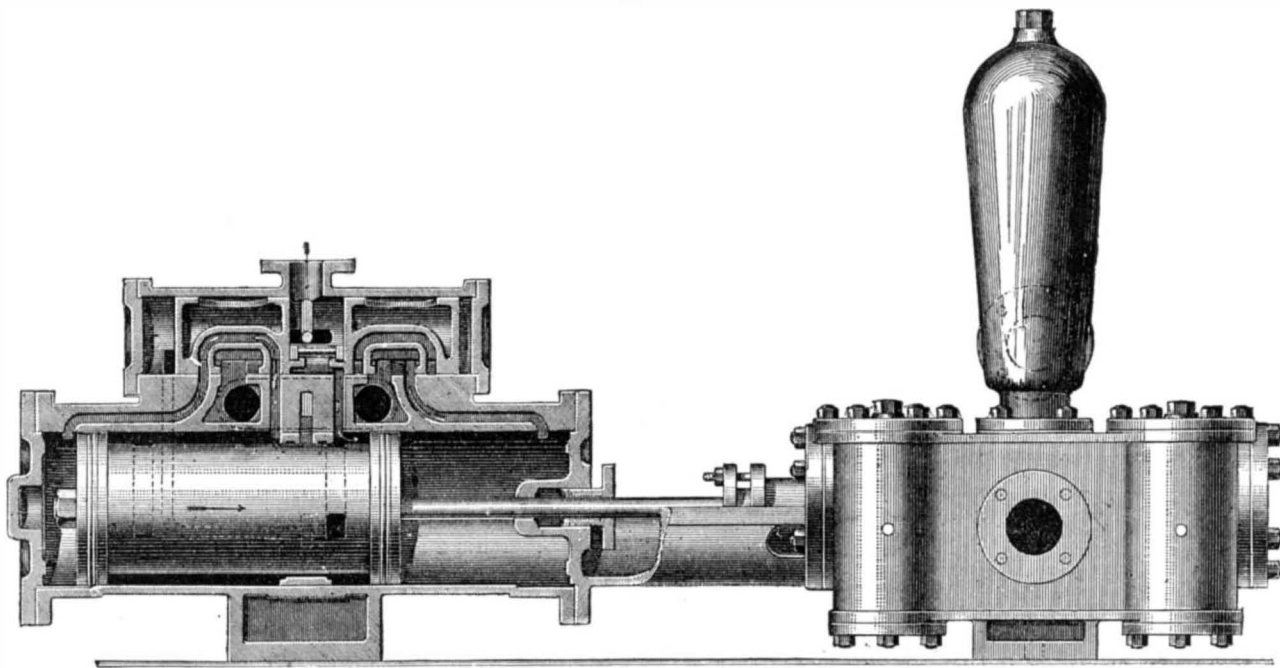

Fig. 2.



**WALKER'S COMPOUND STEAM PUMP.**

to cushion both the piston and valve so as to prevent striking under any circumstances.

For further particulars address the manufacturers, Messrs. E. & A. Betts, Wilmington, Del.

**American Nickel Mines.**

The nickel deposit near the Gap, Lancaster county, Pa., is considered the largest yet discovered in the world, and the only deposit of the ore worked in America. The mine is on the high dividing line between Chester and Pequea Valleys. Besides nickel, copper, iron, and limestone are found in the same locality. Nickel was discovered here about the year 1856, though copper, which is taken from the same mine, was known in the same locality seventy years ago. The ore has a gray color, is very heavy, and so hard that it is mined entirely by blasting. After the ore has been broken into small fragments, it is put into kilns holding eighty or ninety tons each, and subjected to heat produced at first by the burning of a small quantity of wood, and continued by the conversion of the expelled gas. It is then put into a smelting furnace, and undergoes a treatment similar to that of iron ore.

**New Steam Canal Boat.**

A new invention for the propulsion of canal boats was tested at Rochester, N. Y., recently. The peculiarity of this boat is in the position of the propelling wheel or screw. It is placed in the middle of the boat, and works against the water at an angle of thirty-eight degrees, in this way throwing the water against the bottom of the canal instead of horizontally. It works in a casement from which the air is exhausted and which is consequently full of water. On the trial, without a load, three miles an hour was run by a boat to which the screw had been affixed.

**Extension of the Greenwich Railway, London.**

The London and Greenwich Railway was constructed and opened upwards of forty years ago, not long after the opening of the Liverpool and Manchester railway—the first steam passenger railway in England. The Southeastern Company, who are now the owners, have extended it to the North Kent line, *via* Maize Hill, Charlton, and Woolwich, which

places Greenwich in direct railway communication with Gravesend, Chatham, Maidstone, and other districts in North and Mid-Kent.

The old London and Greenwich line is carried entirely on masonry arches, and on a high level, that is to say, it is a city elevated railway. The extension line about to be opened is, however, an underground line, diverges from the elevated line near Deptford Creek, and is thence carried, in a northeasterly direction, along a descending gradient, until it arrives at London street, which it passes under, immediately on the south side of the parish church. In constructing this portion of the line, about 150 houses had to be purchased; and as the whole of one side of a thoroughfare was also absorbed and diverted, the company have had to construct a new street, with a roadway under the new line leading into Greenwich road. At this point a heavy outlay has likewise been incurred by the company in the diversion of about 1,700 feet in length of the main sewer belonging to the Metropolitan Board of Works, near London street. The new sewer, which is carried at a considerable depth under the railway level, is 11½ feet in width. It is circular in form, and lined at the bottom with blue Staffordshire brick, and all round with white gault brick. There are staircases at intervals for the purpose of descending into the sewer from the street. The cost of this sewer was \$260 per yard. From London street, Greenwich, the line is carried forward in a tunnel, 26 feet in width and half a mile in length, which passes under the Royal Naval Schools. At the end of the tunnel the line is carried on to the Maize Hill Station, through a cutting which is walled in throughout its entire length. The portion of the line from Maize Hill to Charlton and Woolwich, where a junction is formed with the North Kent line, was opened nearly two years ago; the entire length of the line from Greenwich to Woolwich is between two and three miles.

The whole of the works have been designed by Mr. Brady, the company's engineer, and executed by Messrs. Lucas & Aird, the contractors.

**MAY'S IMPROVED BILLIARD TABLE LEVELER.**

The invention herewith illustrated is a combination of leg

Fig. 1

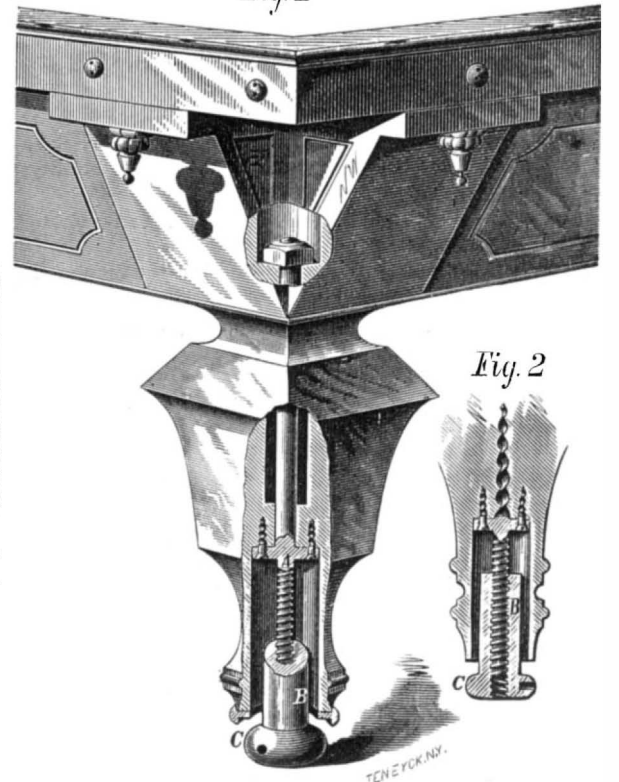

Fig. 2



bolt and leveler, so that a single bolt holds the leveling attachment firmly to the leg, and at the same time secures the latter to the table. In some billiard tables the legs are merely doweled on, but this is liable to give trouble in case

of accident, packing, etc. The screw in the present device is not exposed, and the arrangement generally is neat and substantial, and, we are informed, cheap.

In the lower end of the leg is a deep socket, Fig. 1, through which passes the screw rod, A, on the extremity of which is a long nut, B, having an oval head, C. The leg has preferably a metal cap with a flange, projecting downward to conceal the nut and the upper side of the head thus making a neater finish; or the cap may be omitted, as in Fig. 2, as the nut will ordinarily appear like an ornamental foot.

In Fig. 1 the rod is represented as extending up through the leg into the head block and bolting the leg fast thereto. In Fig. 2 there is simply a short bolt having a wood screw formed on its upper end to enter the wood. A collar is attached on the rod at the point where it rests against the bottom of the socket, when the bolt is screwed home. This is fastened by suitable wood screws entering the leg through the notches on the collar, by means of which the latter is screwed up. The nut, B, is adjusted by a pin put in its hole. The device is well adapted for piano legs or those of bagatelle and other tables requiring to be adjusted level.

Patented to Samuel May through the Scientific American Patent Agency, July 25, 1876. For further particulars address Messrs. Riley & May, 81 Adelaide street west, Toronto, Canada.

### Correspondence.

#### On a Mechanical Theory of Gravitation.

To the Editor of the Scientific American:

The main cause of the failure hitherto to construct a mechanical mode of gravitation action, which would be found consistent with acknowledged scientific principles, in agreement with the facts of observation and mathematical developments of the theory itself, appears to be the supposition that no mode by which tension would be produced is admissible: etherial pressure or impulsion being alone scientifically allowable. But this contradicts experience, and even general analogy. The tension of a cord is used as an elementary illustration; and optical phenomena not only show etherial vibrations to be transversal to the course of propagation, but that in impalpable matter the ether is densest, and therefore probably condensed instead of rarified around it. We have only to suppose the ether to equilibrate by condensation any enforced tension within it (say, by being stressed toward dense matter) to make the propagated vibrations transversal, and their velocity unvarying.

If we assume the energy of the Universe to be concentrated in the continuous mutual transmutations of ether and dense matter, masked by various and transformable modes of manifestation: such transmutation occupying more time than the periods of molecular vibration where radiant energy is displayed, but less time than any molar motion: we can perceive unconstrained translatory motion of masses to be possible even in an absolute plenum, there being merely a transmutation movement. A constant aberration would follow as a natural result. If the thorough transmutation of molecules be less rapid than their general motions, their extra motive forces will be transferred to the ether until the periodic time of motion reaches that of transmutation, when the radiant energy is all dissipated by there being no more etherial resistance.

Such rapidity of transmutation is the only novelty of the present hypothesis. But this assumed rapid action of the constituted forces of matter finds its parallel in the transmutation of force itself: while the principle finds its analogy in physiological action, in which matter assimilated takes on the constituted quality of the matter emitted. This continuity of molecular transmutation implies neither growth nor decay, but simply continuous "manufacture": like molecules having identical properties everywhere, constituting them alike.

I assume the ether to be of equal density throughout, except where differences of pressure or tension are produced, when the density will vary equally by the tendency to maintain equilibrium of condition. But with this difference of density I also (as Professors Challis and Clerk-Maxwell have done) assume that the ether resists any break in its continuity, because:

1. No portion of the Universe can be isolated in its action, nor unaffected by the rest.
2. We avoid making the mathematical quantities of nothingness vastly greater than those of substance.
3. We are more consistent with thermodynamical principles; and
4. We do not contradict common sense in making the dynamic bond of the Universe consist in the isolation and repulsion of its every atom.

If we suppose the process of assimilation carried on with a greater rapidity than is possible for the ether to withdraw the emitted matter into its naturally equable distribution of density throughout free space, a state of stress in the medium towards every particle of dense matter will be necessitated. We need not inquire into the primeval condensation of ether into gross matter; but if it be conceded as a truth, it follows from our hypothesis that the absorption of ether will cause it to be strained towards the gross matter, and be drawn thereto with greater density to equilibrate the tension. The condition of stress will be precisely like that of our atmosphere, the tendency of the condensed ether to expand being balanced by the pull upon it for assimilation. This conception of the ether agrees with that of Newton. In his letter to Boyle, he says: "I suppose that there is diffused through all places an æthereal substance, capable of contraction and dilatation, strongly elastic: in a word, much like air in all respects, but far more su-

tile." The result then would be that the ether contains within itself as many spheres of stress as there are particles of matter: every atom being the center of such a sphere, which may be assumed to reach to any assignable distance, and coeval with the being of the atom.

The force of stress around gross matter is thus the balance between the activity of transmutation and the tendency to etherial dilatation; and an increase of the one would correspond to a decrease in the other. If the ether, by offering increased resistance to transmutation, thereby lowered its activity, an equal and opposite resistance would be developed by the constant tendency of the body to give its transmutative energy free play. Should also, through any cause, the lines of dilatation be deflected perpendicularly to the lines of tension, the energy of transmutation will be lowered in the directions of the latter, the amount of which it is decreased becoming transformed into an equal and opposite reacting tensional force. Therefore, however great the amount of resistance to a body's natural assimilation of ether in order to maintain existence, or the number of directions whence such resistance comes, if the effect merely be to lengthen the period of time in which transmutation takes place, the amount of dense matter remaining constant, equal and opposite counterpulls to all will be developed. Now a body alone in space could be subject to no difference of stress, the self-caused etherial tension around it, being equable, making the lines of force straight outward from it in every direction; and the molecular energy of transmutation in the present condition of the ether would be at a maximum. But the presence of other bodies similarly conditioned would destroy the equilibrium of the ether on the sides toward each other, and its tendency to dilatation would act perpendicularly to the opposing stresses, being the directions of least resistance; and coalescence of the stresses would result, bringing the bodies at their centers together. The sides towards each other, being the sides whence resistance to transmutation comes diminishes therefrom its potential energy, which becomes changed into the actual energy of bodily motion. It will be seen that this theory of the action of gravity is similar in form to Faraday's conception of the action of dissimilar poles when face to face in magnetism, namely, by the coalescence of their lines of force, and which had previously existed in the space between them. For it is plain that, whatever faces of all bodies be turned toward each other, they will bear the character of opposite poles, the lines of steps being directed inward to each from every direction.

Transmutation energy and gravitation action would, according to this, be mutually convertible the former: being diminished by decreasing activity wherever there is a resultant attraction. The resistance to transmutation developed during the coming together of bodies is the equivalent of the motive force given out in yielding to the increasing tension; while the diminished resistance during any enforced withdrawal of them is the equivalent of the work done in overcoming their tendency to come together by the coalescence of their spheres of stress: or in other words, by diminishing such resistance, and increasing transmutation activity.

We can thus see how every particle of matter may be potentially infinite, without being substantially penetrable, and the molecular force of every mass impotent, as regards its own change of rest or motion in the aggregate, while potential in altering the conditions of rest or motion of all others. The fundamental correlation of matter and manifested force is also evident from the result that their dissipation would be mutual, as there could be no equilibrium of stress arrived at in the Universe until all the dense matter became again dissolved into the ether, without possible return into gross substance.

Although the force of tension exercised by different bodies is equal, the distance through which each sphere will be drawn during coalescence will be in the inverse ratio of the masses at their centers. For the potential energy of transmutation in bodies taken as wholes being directly as the masses, a portion of which becomes transformed into kinetic energy while yielding to their mutual tensions, the motive force will be according to the proportional diminution in each of such potential energy required to produce equality of pull. And a transmutation action stresses the ether from every direction; the potency of resistance to it, through the combining of mutual stresses, will be as the number or breadth of surface of the lines of force coalescing. The tensional power of coalescence will thus increase with the concentration of the spheres of stress, being potentially an element of the radial distance from every body. It is evident that particles free to move in any direction will tend to group themselves spherically during aggregation around the point which would be the center for all the spheres of stress were they to become blended into one, being the converging point for the equilibrating tendencies: while it will become the balancing point or center of motion around which would revolve all those bodies whose deviating forces of motion are sufficient to overcome the tendency towards it.

If the efforts of the spheres of stress to coalesce be resisted by the motions of bodies under an opposing impulse, the lines of tension, by being inoperative, will be necessarily accompanied by equal pressures perpendicular to them along their whole length in the tendency to etherial equilibrium, and the tensional force will become constantly neutralized. In the case of any cosmical couple (the only kind of balanced motion in free space) the mutual tensions will be constantly equalled by the motive forces of the bodies acting perpendicularly to them: their joint masses or amounts of transmutation energy determining the measure of both. The

volume of the sphere of stressed ether around which any determinate masses revolve is also, by its internal equilibrating action, a measure of the motive force exercised, or the time occupied in revolution squared. In other words: taking the major axes of any orbits as the diameters of naturally elastic spheres of stressed ether, the times of revolution squared by the bodies producing the stress, divided by the number of units of volume in the sphere around which they revolve, will give the amount of kinetic energy, which is a constant for the same masses throughout all space; or the square root of the number will give the time, which is Kepler's harmonic law, viewed as a physical reality.

To give the appearance of a physical reality to the fundamental law of the heavenly motions might thus be consistently formulated:

An infinite sphere of stress and proportional condensation of ether is produced around every body by rapid mutual transmutation of substance, and resistance to breach of continuity, which, while permeating, is constantly striving to coalesce with all others in the effort towards etherial equilibrium: thereby resisting all impressed tendencies of the central masses to recession by altering the direction of their paths, combining with them in coupled motions, or bringing them together with a force inversely as the squares of their distances: the coalescing energies and moments of cosmical couples being directly as the masses.

Philadelphia, Pa.

WM. DENOVAN.

#### Zinc as a Preventive of Boiler Incrustation.

To the Editor of the Scientific American.

The articles on zinc as a remedy for boiler incrustation recall to my recollection an experiment of some magnitude in that direction, made half a dozen years ago by a party of which I was a member. Experiments on a smaller scale than that in question had proved that iron in contact with zinc was not only protected from corrosion during immersion in most fluids, but that any covering upon the iron would be removed by the action of one of these metals upon the other, or by their mutual action. This action was not confined in its operation to salts, oxides, resins, grease, and dirt of all sorts; but in some instances it loosened electro-plating. When the iron became perfectly clean, and the condition of the fluid used admitted of it, the latter when charged with oxide of zinc deposited the metal upon the iron by the well known galvanic process. The oxide of iron was removed with the same facility as any other substance; and this latter fact probably originated the prejudice against whatever thoroughly cleanses the boiler, such cleansing being supposed by some to cause leakage. Doubtless this mode of cleansing a boiler would take out iron rust even from the joints of the plates; but this should be taken as a needed premonition of danger, and the iron itself is absolutely protected from further oxidation in the presence of the zinc.

The experiment alluded to was within the boiler of an ocean steamer, plying between this port and Savannah. Zinc was introduced and suspended upon the tubes near the points of incrustation, and sundry necessary conditions were provided. At the termination of the trip, it was found that the zinc which was, wrongly, in sheets, had fallen down, having separated at the fold or bend over the tubes; it was eaten up at these points. The crust was about one third the usual thickness, showing, perhaps, that the trip was two thirds performed before incrustation began. The crust consisted of the usual salts accumulating in the use of sea water, and was deposited upon the zinc as well as on the boiler; but under the crust on the zinc, and between the two, was a uniform coating of black oxide of zinc in contact with and lying upon the latter. Clearly this oxide was placed there before incrustation took place; and my impression is that none would have been deposited if the metal sheets had been substantial enough to resist the wear and tear and the increasing weakness from oxidation. The remaining zinc and the crust, with the oxide between them, separated almost with a touch.

Although this experiment was in itself a failure, it was deemed conclusive of the fact as to the operation of zinc in preventing incrustation in boilers.

Baltimore, Md.

#### Weight in a Hollow Sphere.

To the Editor of the Scientific American:

I have been interested in reading the communications that have recently appeared in the SCIENTIFIC AMERICAN in support of the hollow sphere theorem, notably those from Messrs. Pratt and Palin, page 181, current volume, each of which is an unanswerable demonstration of the truthfulness of the said theorem. The single point upon which I stumbled, as it clearly appears, was in assuming the force of gravity, as measured at the surfaces of spheres differing in size, to be directly as their respective masses. Upon this point the whole matter turns; and the proportions supposed to be hostile are at once harmonized. I was conscientious in my attack upon the theorem, doubting its truth; and it was my purpose to do so vigorously, and to use terms as to the significance of which there could be no mistake, hoping to provoke a controversy that would result either in its complete vindication or overthrow. I now cheerfully acknowledge my error, and am as thoroughly convinced of the truth of this oddly appearing theorem as I am of the truth of the properties of the triangle.

Rochester, N. Y.

E. B. WHITMORE.

THE French meter is inaccurate to the extent of  $\frac{1}{370}$  of its length. Is short that much. So said Professor Hilgard to the scientists the other day.



**THE CENTENNIAL INTERNATIONAL RIFLE MATCH.**

The international contest between the five best rifle teams in the world has resulted in a substantial victory for the American marksmen. The match was organized under the auspices of the Centennial Commission and held at Creedmoor near this city, and the American riflemen were brought in competition with picked teams representing the crack shots of Canada, Ireland, Scotland, and Australia. The contest lasted during two successive days, and on each day each marksman fired fifteen shots, respectively at targets located at distances of 800, 900, and 1,000 yards. The system of counting hitherto practised was employed, a bulls-eye marking 5, a center 4, an inner 3, and an outer 2, so that the highest amount possible to make by any fifteen shots was 75. At the end of the first day, the Scotch team led, the total scores footing up as follows: Scotch, 1,586; Irish, 1,582; Americans, 1,577; Australian, 1,545; and Canadian, 1,490. On the second day, however, the Americans worked steadily ahead, making a final score of 3,126 points, which left them 22 ahead of the Irish, who were second with a score of 3,104 points, and 64 over the Scotch, who netted 3,062 points in the two days shooting. The Australians finished with a score of 3,062, and the Canadians came last with a score of 2,923.

Some shooting was accomplished which, when the accidental difficulties to which the marksman is subject are considered, was simply marvelous. Two of the three distances shot over exceed half a mile. To obtain an idea how a target, having a bulls-eye 3 feet in diameter, looks to the rifleman when located so far away, pin this paper to the wall and regard the diagram herewith given from a distance of 20 feet. The black dot in the center then represents the exact size of the bulls-eye 1,000 yards away. To hit a mere speck like this is certainly difficult enough; but there are numerous accidental disturbances which combine to vitiate the straightest aim.



If the wind is blowing with the direction of the bullet, the latter is accelerated; and unless allowance is made, the shot flies over the target. If the wind blows in reverse direction, then the bullet is retarded, and is liable to fall short. In case of a side wind, the bullet is apt to deviate; while the grooving of the rifle gives the bullet a natural drift to the right. A "fishtail wind," which blows partly up or down the range and partly across, with varying strength as well, is extremely perplexing, and the sights on the rifles are readjusted for every shot. If the ground be damp and the sun hot, a shimmer of mist on the surface makes the target appear to dance; variations of light and shade apparently lift or depress the target center; heat and cold affect the metal of the gun. Then, besides, the bullets must be perfectly smooth and of uniform density, and the rifle perfectly clean. After all this, when the man has learned to hold his rifle true to the little bubble of the spirit gage which rests between the front and rear sights and across the barrel, and can hold it with a vice-like grasp, can repress for a moment all motion, and hold his head as steady as a rock and pull the 3 lbs. resistance of the trigger, and care not at all for the 200 lbs. kick which the rifle gives a shoulder probably already black and blue through previous blows, then, if he has not misjudged in any particular, he stands a chance of hitting the bulls-eye. Now imagine men overcoming all these difficulties and making such targets as these here reproduced. No. 1 shows 15 bullseyes in succession, the finest target ever made at 1,000 yards. It counts 75. This was done by Mr. J. K. Millner, of the Irish team. The second best target at the same range is given in No. 2. The count is 73, made by Dr. J. Mitchell, of the Scotch team.

The next two targets are the best at 900 yards. No. 3 was made by Mr. R. Rathbone, of the American team, and counts 72, and No. 4, by Mr. R. McVittie, of the Scotch team, scores 71.

The last two targets are the best at 800 yards. No. 5 is another very remarkable instance of 15 bullseyes in succession, made by Mr. E. Johnson, of the Irish team; and No. 6, by Mr. N. Thorburn, of the Scotch team, counts 73.

**HEATING BY STEAM.**

"The frequent occurrence, during the past few months, of fires in steam-heated buildings and dry kilns, and more particularly the burning last week of the dryer attached to the Mason Lumber Company's mill, at Muskegon, Mich., which I understand was of this type, must lead every one who has occasion to use steam heat, in any way, to inquire what causes them.

"It is certainly time that this subject should be more carefully and scientifically studied, and I think when the matter is better understood that all will be convinced that the trouble is not in the steam pipes or steam heating, but only in the imperfect construction of the heating apparatus. It matters not how the heat is produced, whether by steam, furnace, or hot water; all may be alike safe, or all dangerous, only dependent on how it is generated and applied. During the last decade I have examined hundreds of steam-heated dry rooms, and I am satisfied that, in a large majority of cases, either the supply pipe or a large part of the heating pipes have been supported by wood, and, in many cases, the former packed in sawdust and shut completely from the air. I have seen a pine timber six inches square and eighteen feet long (on which a 4-inch steam supply pipe has laid for

months in daily use), when removed, so charred that I could not split off pieces from one to two feet long with my hands, it breaking almost as readily as charcoal. Again, I have seen sawdust, that had been long packed around a steam pipe, so browned or scorched as to be almost black. I have also seen, in dwelling houses where tin conductors are used to carry the heat from a furnace, the pipe nailed to the wood, and upon examination have found the wood so charred around the nails that they could be removed with the fingers. The latter occurs most frequently directly below the register, and is the result of closing the valve, thus stopping the flow of air and confining the heat; while the fire in the furnace burns on as if the register was open. This explains why so many houses burn down where furnaces are used. But steam heat will accumulate as well as any other.

"Place a pipe on a wood support or closely pack it with any combustible material; and there being no circulation of air between the pipe and the wood, the heat is confined and accumulated, until at last, the conditions being just right, ignition is effected and all is gone. In other words the principle of accumulation applied to heat will make anything hot or burn any combustible substance up at last. In science I believe they call this law "the accession of forces"; it may be tested and illustrated by any one. Let any man who uses steam put his hand lightly on any heated pipe, and he may hold it there for several seconds without inconvenience. But let him grasp the same pipe with a firm grip, and, although the temperature of the pipe is not changed, he at once feels an increase of heat, and in a moment his hand will be blistered wherever it comes in contact with the iron. Now suppose we bind the hand there, and surround it with sawdust or any other non-conducting substance; how long would it take to literally roast that hand and cook all the flesh off the bones? Only a few hours at most. What then is the law? Simply that of holding the heat; and although received at only 212°, by keeping all we get and taking all that comes, it soon runs that up to 250°, 300°, or more. Now the hand might be held within one half inch of that pipe all day and no inconvenience felt, as the free circulation of air would prevent the temperature increasing. The law I understand to be the same, whether it is a hand, a piece of wood, or any other substance, that incloses the pipe. If we cut off the circulation of the air next to the pipe and surround it with a poor conductor like wood, the heat must accumulate, and doubtless often does, to the point of ignition of.

"When we lay our pipe on wood we convey the motion on the fire along the pipe by the steam, and it again passes into the wood under the pipe, where it accumulates and increases until the ignition point is reached and the wood takes fire."

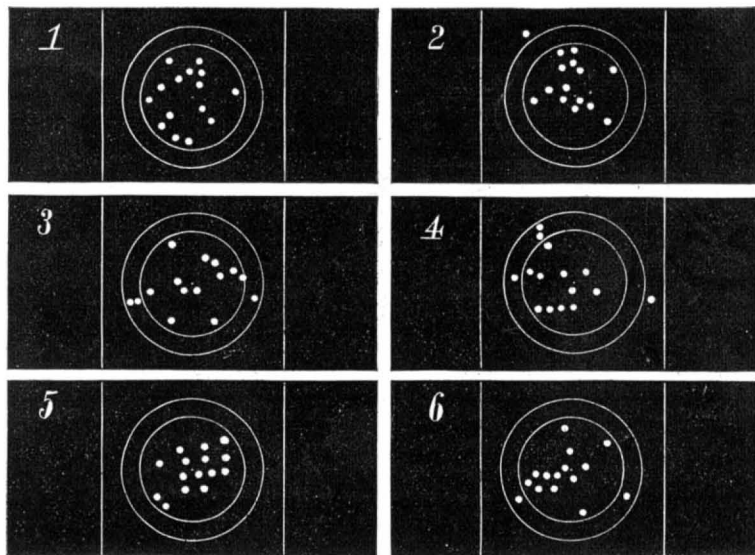

The foregoing is from a letter from "H." to the *Northwestern Lumberman*; it is excellently written, and contains pertinent and interesting examples, but unfortunately it reaches a conclusion which is altogether baseless. The temperature of saturated steam depends on the pressure, and it cannot be augmented without augmenting the pressure likewise. In order, however, to check the too free radiation of heat and consequent diminution of pressure, we felt or jacket boilers, steam pipes, cylinders, etc. These roughly stated facts are part of the A B C of engineering; but the above writer seems to have forgotten them, and he commits the more grievous scientific error of confounding the mechanical energy resident in steam with the physical properties of that vapor. Some brief reasoning will show this, and may prove interesting. Professor Trowbridge, in his recent work on "Heat and Heat Engines," admirably defines a steam boiler as "the apparatus by which, through the process of combustion, a rapid degree of heat motion is developed in the fuel and gaseous products of combustion and transferred to the particles of water." These last, in a steam-heating apparatus, communicate their heat motion to the molecules of their pipes or other enclosing vessels, thence the heat motion passes to the air molecules, and lastly to the molecules of our bodies, and the sensation called warmth is experienced. Now if we interpose any substance which prevents or retards these waves of heat at any point of their transmission, we merely confine them or render their escape slower. We do not accumulate them. The case is analogous to that of a suspended weight; the energy is there constant so long as gravity acts; it is in potential form; cut the string and the weight falls, and in so doing does work. It will not be pretended that the weight will exercise any more potent effect by hanging two hours or two centuries. No additional power is stored up. Now the steam pipe unjacketed communicates heat motion, jacketed it does not. The jacket in this case is the same as the cord which suspends the weight in the other, for heat and mechanical energy are mutually convertible. Obviously then no more additional heat is stored in the first than force or energy in the second instance. Further, if by jacketing through accumulation we can augment heat,

therefore we augment mechanical energy, therefore we obtain an accession of power through a purely mechanical device, and therefore we land in the principle of a perpetual motion.

The error lies, as we said before, in confusing the molecules of steam with their mode of motion. Shut steam up in an invariable space and apply heat continuously, and temperature and pressure will steadily increase until the last element of liquid vaporizes and then the steam goes on to assume the properties of a permanent gas. But it will not do to confound the steam jacket with the safety valve, and such the above writer seems to have done.

As regards the ignition of wood, etc., by steam pipes, the true theory is pretty well settled as follows: The temperature of saturated steam, such as circulates in heating pipes, even at the unusual pressure of 120 lbs., reaches but 341° Fah. The temperature of 900° is about that of the red heat necessary to set dry woodwork on fire, so that it must be clear that saturated steam can never directly excite a conflagration.

The molecular conditions under which the oxidation, resulting in spontaneous combustion in many substances, occurs originate at a very much less temperature than 341°; and it would appear that under certain circumstances the heat of steam pipes is sufficient to determine these conditions in certain woods. There is good ground for crediting the idea that two circumstances here play a prominent part. These are, first, that the wood or other fibrous material must be, by protracted heat and dryness, reduced to a punk-like state in which it is easily friable, and, second, that it becomes pulverized and so offers a very large surface to the effects of oxidation, which last are assisted by the high temperature of the contiguous pipes. Some woods are more liable to become in punk state than others; and if the foregoing probabilities, through that much needed thorough investigation into the whole subject which we have long hoped to see, be rendered certainties, then it will be one of the first duties of architects to avoid such woods in house construction.

The above, in our opinion, is the true philosophy of the phenomenon; but if the writer of the foregoing extract or any reader still feels inclined to adhere to his "accumulation" theory, it is only necessary to fasten a thermometer against a steam pipe, cover it well with felt, and observe, after a few hours or so, whether the mercury rises beyond the known temperature of the steam corresponding to the pressure.

**Those Collided Locomotives.**

In our issue of July 1 last, we published a large engraving of a railway collision, wherein the two locomotives, on meeting, had reared up in a most remarkable manner and remained sitting, as it were, on the ends of their respective fire boxes. We stated that our illustration was prepared from a photograph of the actual scene, but where the event took place we were unable to affirm, and therefore asked of our readers any information leading to the discovery of both railroad and locality. We received in reply a host of letters. Some writers detailed accidents which happened long ago, which they were sure were the foundation of the picture, while others doubted the veritability of the occurrence and even took us to task for being so easily imposed upon. Others again, not content with mere assertion, exercised much ingenuity in explaining to us in detail how the appearance of the various parts of the engines and appendages utterly negatived the idea of any such collision.

The upshot was that we determined to ferret the matter out, and we have done so. In the *SCIENTIFIC AMERICAN SUPPLEMENT*, of even date with the present number, will be found the whole story. We publish several of our doubting correspondents' letters, and also that of the person who prepared the original photograph. The collection is extremely amusing and interesting, the latter especially, inasmuch as the circumstances of the strange collision are fully explained.

**Arrival of German Workmen.**

Two delegations of French workmen have been over to visit the Centennial, and have returned to their native country. The steamer Mosel, lately arrived in this city, brought a delegation of German workmen, members of the Berlin Central Bureau for the Benefit of Workmen. The following are their names and trades:

Albert Anderleit, locksmith; Otto Bærwolff, draftsman; J. Berckenhagen, engineer; Eduard Breslau, engineer; Carl Burchardt, engineer; Carl Cario, technician; George Daunert, technician; Richard Fleck, machinist; Richard Fleischer, engineer; Oscar Hadank, goldsmith; Joseph Hoffmann, tinsmith; Wilhelm Kraemer, technician; Johannes Leman, of Polytechnic Academy of Berlin; Joseph Luedtke, printer; Robert Maerz, engineer; Louis Meissner, engraver; Otto Neumann, mechanic; Franz Pest, copper-smith; Otto Pils, engineer; George Rodenwoldt, architect; H. A. Schneider, boot maker, etc.; O. Schneider, draftsman; Julius Schreiner, sculptor; Oswald Strasser, engineer; Carl Strietzel, technician; Max Unger, of Polytechnic Academy, Berlin; J. Wichelmann, goldsmith; Carl Wirth, sculptor.

**Free Trade with the Sandwich Islands.**

By the terms of the new treaty made with the Hawaiian Islands, the following products may be imported duty free: Arrowroot, castor oil, bananas, nuts, vegetables, dried and undried, preserved and preserved; hides and skins undressed; rice, pulu, seeds, plants, shrubs, and trees; muscovado, brown, and all other unrefined sugar, meaning hereby the grades of sugar heretofore commonly imported from the Hawaiian Islands and now known in the markets of San Francisco and Portland as Sandwich Island sugar; sirups of sugar cane, melado, and molasses; tallow.



**REMOVAL OF THE HELL GATE ROCKS.**

The great obstruction impeding the ship travel between the Atlantic ocean and New York city *via* Long Island Sound is located at a promontory of Long Island, called Hallett's Point; it extends out into the East river, approaching Ward's Island, which occupies three fifths of the width of the river at that point, and some dangerous rocks are found in the immediate vicinity. The narrow channel thus formed has been a danger and a difficulty to navigators ever since this part of the country was first explored, and the rush of water taking place through the pass gave it the name of Whorl Gate, afterwards Hurl Gate, whence the name by which it is now known was easily derived.

Our readers have been informed, from time to time, of the progress of the great work of excavation, which has now been completed; and the blast which will shortly take place will put an end to the difficulty in navigating this now dangerous pass, and end the years of labor that have been so perseveringly bestowed upon it. A very widespread interest has been centered on the operations; and the work is one of national importance, although this city is of course more interested in it than any other section of the country.

The first mention of preparations for commencing this work is found in the report by Lieutenants Davis and Porter, of the United States navy, made in the year 1848. This document gives a very accurate description of the course of the tidal currents, the dangers to navigation caused by rocks, obstructions, etc.; and it recommends that Pot Rock, the Frying Pan, and Way's Reef be blasted and scattered. The two former are single rocks of a pointed shape; the latter is long and has the character of a ledge. The report also recommends that the middle channel be improved by blasting so as to make a clear channel of sufficient depth for common vessels and steamboats; and it also speaks of the increased facilities for naval defence which this improvement would afford. The difficulty of blockading the port of New York, with her two outlets instead of one, would be at least doubled. Lieutenant Porter did not exactly agree with Lieutenant Davis as to the best plan for

improving the channel. They both recommended the removal of the small rocks—Frying Pan and Pot Rock—from the middle of the channel, and Porter included a part of the reef at Hallett's Point, the shell of which is now so nearly ready to be blown into atoms, its interior having been removed and deposited far away on dry land. But the art of blasting under water was almost unknown at that time, and engineers agree that even the little improvement recom-

In 1852, Congress having made an appropriation of \$20,000 for the removal of rocks at Hell Gate, Major Fraser, of the Engineers, began operations according to the Mailfert process above described. The sum of \$18,000 was expended on Pot Rock, and the depth of water was increased from 18.3 feet to 20.6 feet.

This is all that had been accomplished up to 1868, when the duty of an examination of Hell Gate was committed to General Newton, of the United States Engineers, who made his report in January, 1867. For operating on the rocks in the middle of the channel a steam drilling cupola scow was constructed. It had a well hole in it 32 feet in diameter, through which 21 drills were worked, while the scow lay on the surface of the water directly over the rock to be operated on. This formidable machine was first used in the spring of 1869, on Diamond Reef. A large number of holes were drilled into this rock, varying from 7 to 13 feet in depth, 4½ feet in diameter at the top and 3½ at the bottom, and the rock was broken up by charges of nitro-glycerin of from 30 to 35 lbs. Coenties Reef was operated on in 1871. Ninety-three holes were drilled and charged with nitro-glycerin, and seventeen surface blasts were made. In 1873, three hundred and seven holes more were drilled and thirty-nine surface blasts were made. The amount of nitro-glycerin consumed was 17,127 lbs., and the reef was thoroughly broken up. The debris had been partly removed, when, in 1875, Congress, owing to a mere clerical blunder, failed to include Diamond Reef in the appropriation, and work at that place had to be suspended. In 1872 the drilling scow was towed to Frying Pan Rock. Seventeen holes were drilled

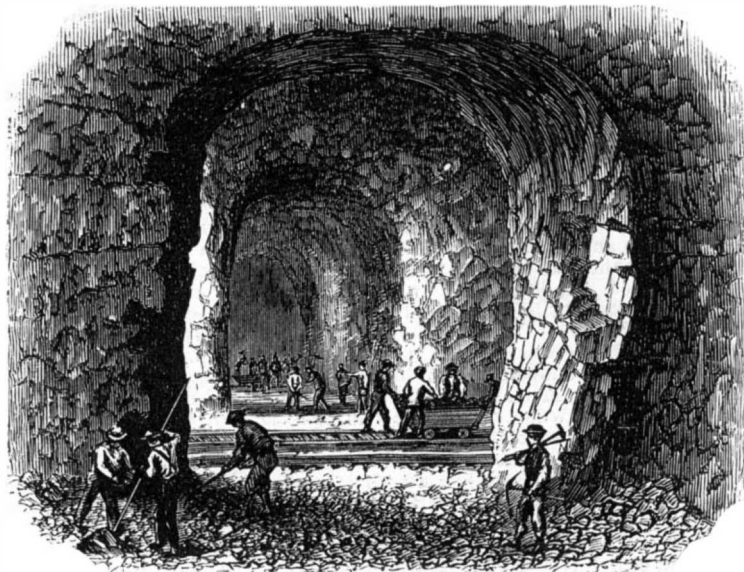

Fig. 2.—SECTION VIEW OF A TRANSVERSE AVENUE, HELL GATE.

mended by them could not have been effected without the inventions and discoveries which have since been made. The process adopted in those times for submarine blasting was to take down cans of powder, place them against the side or top of the rock, and explode them by means of a galvanic battery. This did well enough for rough and jagged rocks and boulders; but so soon as the surface had been leveled off, it was of little or no use to attempt to continue the operation.

and eleven surface blasts made.

**COMMENCING THE WORK.**

Operations for removing the reef at Hallett's Point were begun in August, 1869. A coffer dam was built of heavy timber, securely fastened to the rocks by bolts passing through the framework. This structure is shown in our engraving, Fig. 1.

The coffer dam was pumped out about the middle of October, and operations on the interior for sinking the shaft

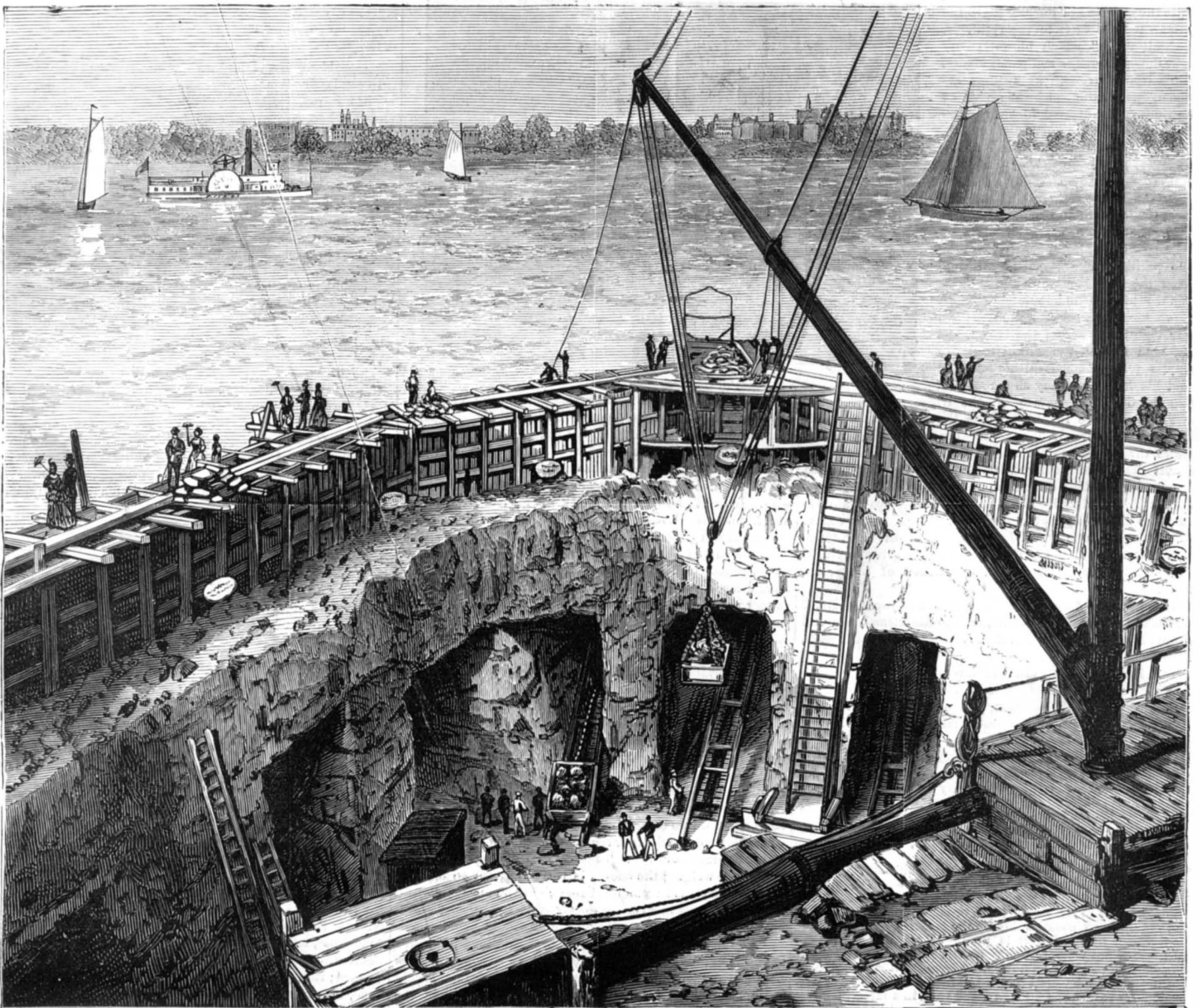

Fig. 1.—COFFER DAM, MAIN SHAFT, AND ENTRANCE TO HEADINGS, HELL GATE, EAST RIVER.



were begun early in November, and continued till the middle of June, 1870, when work was suspended on account of the funds appropriated for this part of the work being exhausted. At that time 484 cubic yards of rock had been taken out, at a cost of \$5.75 per yard. In the latter part of July, operations were resumed, and during that fiscal year the shaft was sunk to the required depth of 33 feet below mean low water, and the heads of the ten tunnels opened to distances varying from 51 to 126 feet. Two of the cross galleries had also been opened. The amount of rock excavated from this place that year was 8,306 cubic yards, and the drilling was all done by hand. During the next year the use of steam drills partially succeeded hand drilling, and the work was pushed more rapidly. The number of feet of tunnel driven during the year was 1,653, and of transverse galleries 653.75. The quantity of rock removed was 8,293 cubic yards.

A sectional view of one of the cross galleries or avenues is given in our engraving Fig. 2; and a ground plan of the work, Fig. 3, gives an excellent idea of the extent of the excavation, which is now complete. A longitudinal section of one tunnel, called by General Newton "Grant heading," is given in Fig. 4.

An exceedingly well executed model of the works is now on exhibition in the United States Government Building at the Centennial Exposition at Philadelphia. It is made exactly to scale, and well represents the nature and extent of the vast operations that have now been successfully completed. The rock bed of the river is, in the model, raised from the pillars that support it, so that a close inspection of the interior may be made. There are 172 of these pillars, pierced with about 4,000 drill holes; and the shell, or roof, or bed of the river varies from 6 to 16 feet in thickness. No less than 30,000 cubic yards of broken stone will be left under water, all of which will have to be removed by dredging. The model referred to is accurately represented in our Fig. 5, and Fig. 6 shows a birdseye view of Hallett's Point, with the large cofferdam inclosing the entrance to the submarine works.

THE RIVER SURVEY.

A detailed survey of the upper surface of the reef was made in 1871 by Mr. William Preass, assisted by Mr. F. Sylvester. They took more than 16,000 soundings, each separately located, by means of instruments, from the shore. Great pains were taken to delineate exactly the surface of the rocks. The appropriation of 1871 was \$225,000, just one half the amount asked for by General Newton, who regretted that the beginning of operations on the Gridiron was thus prevented, as he considered this rock more dangerous to the navigation of large vessels than the Hallett's Point reef. For the next year he asked \$600,000, but got less than half that sum. About the middle of November, 1873, work was suspended for want of funds, but at the end of the fiscal year, June 30, 1874, it was found that, for the four months and a half during which operations had been carried on, 896 linear feet of tunnels had been opened, and 4,648 cubic yards of rock removed. The total length of tunnels and galleries then amounted to 6,780.67 feet. The excavation now being nearly finished, the manner of finally blowing up the whole mine began to exercise the minds of the engineers.

EFFECTING THE BLAST.

General Newton finally suggested his

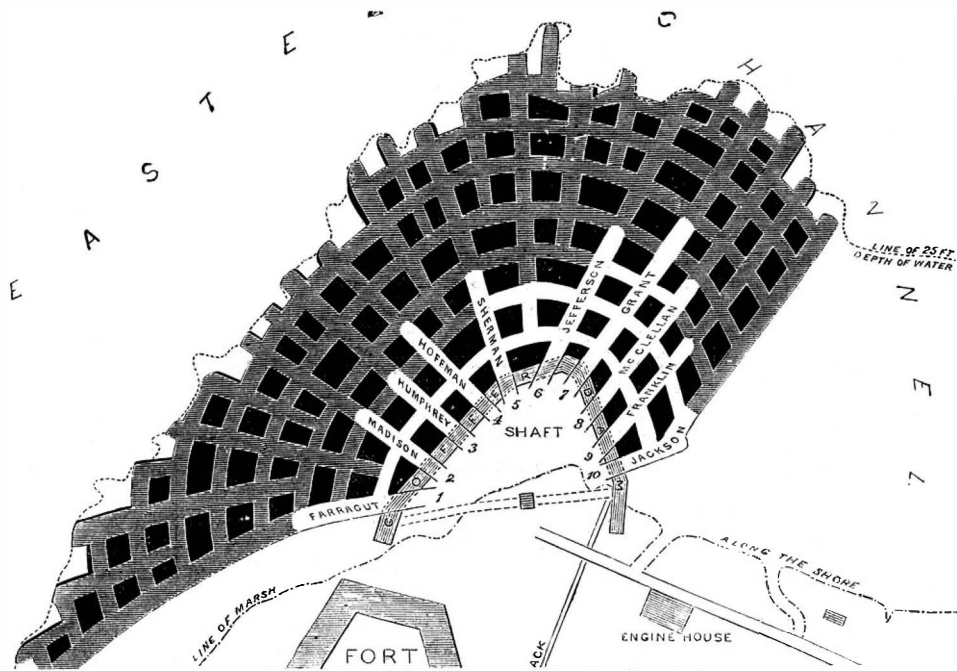

Fig. 3.—GROUND PLAN OF THE WORK AT HELL GATE.

own plan for blowing up the reef at Hallett's Point, which was to perforate each pier with drill holes entirely or partly through its mass, a sufficient number of those being provided to complete the destruction of the pier when fully

the water, will be small.

THE FORM OF THE REEF.

Hallett's Point Reef is in the shape of an irregular semi-ellipse, the major axis, which lies next to the shore, being 770 feet in length, and the minor axis, projecting straight into the channel, about 300 feet. The cubic contents, above the depth of twenty-six feet at mean low water, amount to 51,000 yards. Besides the risk of striking the reef, it produces eddies on both sides of it according to the direction of the tidal currents, and is much in the way of vessels coming down in the ebb in the effort to hug the shore and thus avoid being drawn upon the Middle Reef.

THE EXPLOSIVES.

The explosives used in tunneling at Hallett's Point have been nitro-glycerin and its compounds, and gunpowder, the latter being used only when the rock was weak and seamy. Nitro-glycerin was always used for driving the headings of the tunnels. To drive a

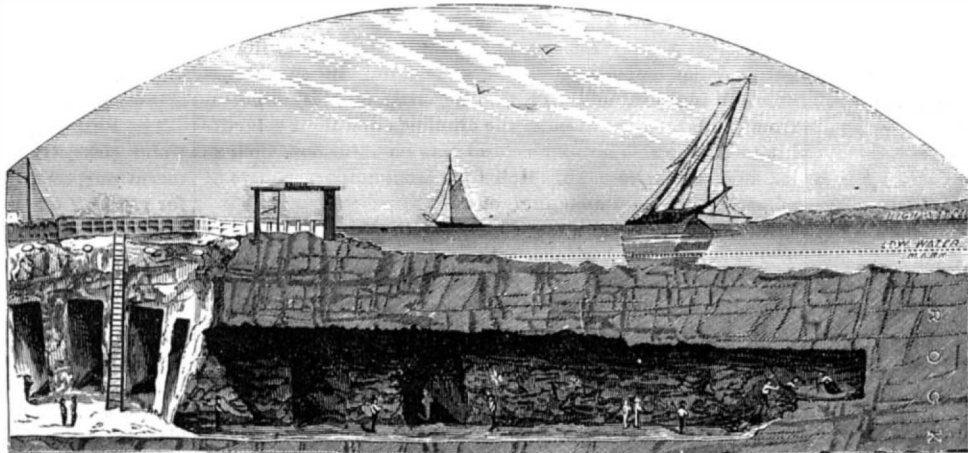

Fig. 4.—LONGITUDINAL SECTION OF GRANT HEADING.

heading, the drill holes are made at an angle with the face, so that the charge lifts out the rock by its explosion. A cavity being made in the middle of the heading, holes are drilled around it and the surrounding rock blown into it. Only one blast is exploded at a time, as great care has to be taken not to shake the structure overhead by too heavy vibrations. There is consequently no volley firing, and the

galvanic battery is not used for discharging the blasts.

THE DRILLING.

The average of twelve months' work with six Burleigh drills was the excavation of 235 lineal feet of heading per month. Up to June, 1872, the work had been prosecuted by hand drilling, with the exception of 20,160 lineal feet of drilling by the Burleigh drill, and 7,000 feet by the diamond drill. That by the Burleigh drills was done by contract at so much a foot; and the diamond drill, purchased for the purpose of exploring the rock ahead, was put in competition with it. The cost of drilling, after a long trial with the Burleigh drill, is found to be between 36 and 37 cents per foot, including repairs, etc. The cost of hammer drilling was found to be about 95 cents per foot. The number of feet of holes, drilled by each machine per shift of eight hours, was 30 feet. The diamond drill, owing to the encounter of frequent

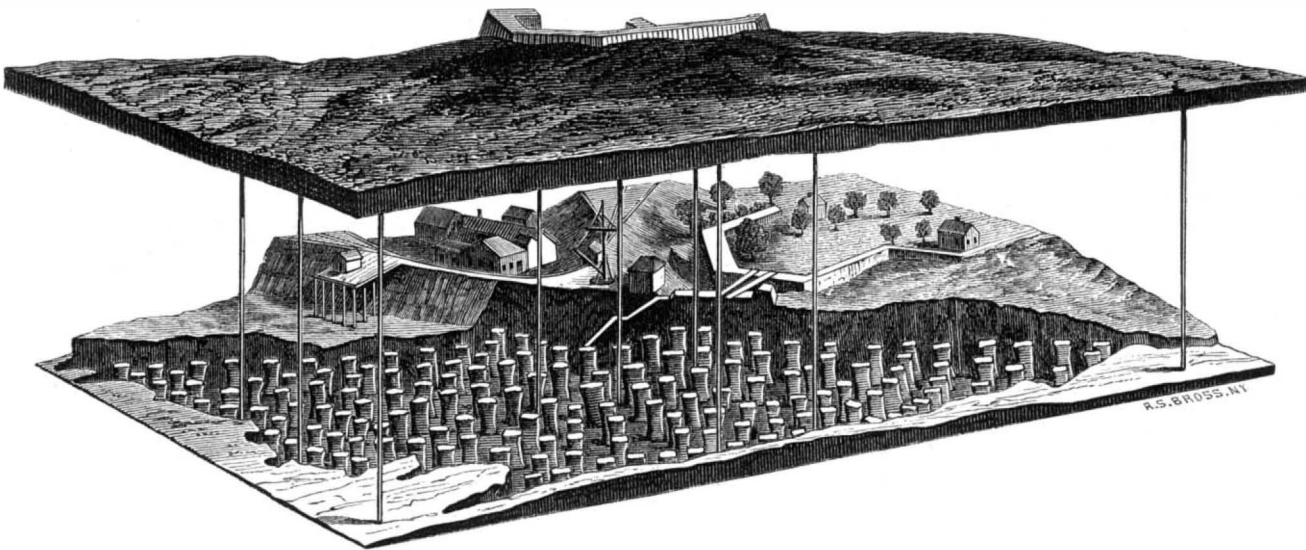

Fig. 5.—THE CENTENNIAL MODEL OF THE HELL GATE WORK.

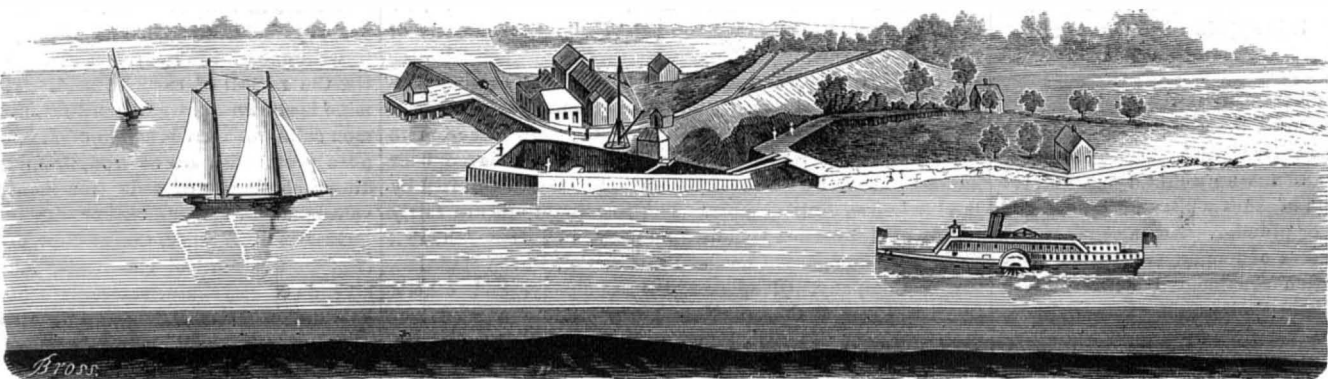

Fig. 6.—BIRDSEYE VIEW OF HALLETT'S POINT, SHOWING THE COFFER DAM.

veins of pure quartz in the rock, often gives out and has to be repaired. Owing to the restricted area of the tunnels and galleries, the work of excavation was almost exclusively that denominated heading, without the advantage of enlargement. The rock, after being blasted, was lifted by hand into a box resting on a truck car, which was run down to the place upon a rail track, and thence drawn by a mule to the shaft, where the box was hoisted by a derrick and its contents emptied into the dump cars, to be rolled away and deposited in the pile. Calling the cost of blasting and removing one cubic yard \$1.00, the following gives the proportion of each item of expenditure:

Blasting	0.46
Transporting rock to shaft	0.17
Hoisting	0.928
Dumping	0.0203
Pumping	0.1087
Incidental	0.2132
	\$1.00

The work of excavation having been finished, the drills were set to work perforating the roof and piers with holes to receive the final charges which are to explode the mine. These holes were made from two to three inches in diameter, and from six to ten feet apart, and their average depth was about nine feet. The size of the holes and their direction and distances apart were made to vary according to the character of the rock to be broken. The drilling of these holes up into the roof of the mine soon increased the leakage of water into the works from 300 gallons per minute to 500, it being impossible to avoid tapping a seam occasionally. Many of the holes that were found to be leaking were plugged up temporarily, and the leakage thus reduced. The outside gallery and the No. 4 heading were deepened so as to concentrate all the leakage, and cause it to flow to the shaft end of that heading, where the pumps were placed.

#### THE COST OF THE WORK.

The following shows the amount of the appropriations made by Congress each year for the Hell Gate and East River improvement, and the whole amount expended up to the date of the last report of General Newton to the chief engineer:

1868	\$85,000	1873	\$225,000
1869	180,000	1874	250,000
1870	250,000	1875	250,000
1871	225,000		
1872	225,000	Total	\$1,690,000
Amount expended, \$1,434,129.59.			

Since this report was made, Congress has appropriated \$250,000.

Total amount of appropriations to date	\$1,940,000.00
Total amount expended to August 1, 1876	1,686,841.45
Estimated cost of completing the entire work of improving Hell Gate and the East River	5,139,120.00

Care has been taken to test the various kinds of explosives. Up to the middle of 1874, nitro-glycerin had been principally used for blasting purposes. Several hundred lbs. of mica powder were then tried, some giant powder, several thousand lbs. of rendrock, and later considerable vulcan powder was used. All of these are nitro-glycerin compounds. Neither of them was found to be as powerful as the glycerin itself; but it was repeatedly demonstrated that, with 10 ozs. of rendrock or vulcan powder, they could break as much rock as they formerly did with 8 ozs. of nitro-glycerin, while the cost per lb. was less than one half that of the glycerin.

#### THE FINAL EXPLOSION.

The blast is to be effected by 96 batteries of 10 cells each, which are to be placed in a bombproof structure. The cells are charged with the fluid known as electro-poison and bichromate of potash in dilute sulphuric acid. The zinc and carbon plates are 4x6 inches, and oppose an area when lowered into the fluid of 40 square inches each. The cells are connected for intensity, about 42 of them forming one battery, the intensity of which is sufficient to ignite simultaneously one set, consisting of eight groups of 20 fuses in continuous circuit, equivalent to 160 fuses. There are, in all, 23 sets to be exploded by 23 such batteries. In order to ensure the simultaneous explosion of these 23 times 160 fuses, a novel apparatus will be interposed into the circuit of each of these independent sets. The apparatus consists of a gravity circuit closer, a brass pin closing the open circuit when the batteries are lowered down, after the charging of the mines is finished, by dropping into a cup filled with mercury, both brass cup and pin being part of the circuit. It is understood that there are 23 brass pins and as many mercury cups in the instrument forming the circuit closer. The simultaneous explosion of all the mines will hence, if no accident changes the programme, be accomplished in the following way: After the wires are connected with the poles of the battery, and the brass pin and cup respectively, the plate containing the brass pin is to be lifted and held by a cord containing the fuse, the destruction of which, by a separate battery, will cause the closing of the circuit by the contact of the brass pins with the mercury in the cups, and the explosion must follow. It is appointed to take place on Thursday, September 21.

#### Discovery at Pompeii.

A discovery has been made at Pompeii, consisting of a number of objects of gold and silver, and close to them the carbonized skeletons of two men, who would seem to have been borne down in the storm of ashes while endeavouring to escape with their valuables or plunder. Among the articles found are eight rings, six pieces of money, two pairs of earrings, two large armlets, each ornamented with thirteen pairs of half globes, with little shells upon them, held together by chainwork, and a necklace of chainwork, all of gold; a silver ring, 332 pieces of silver money, a *casserole* of the same material broken in pieces, and three large bronze coins.

The city of Pompeii, it will be remembered, was complete-

ly buried up in the year 79, nearly 1,800 years ago, by ashes from the neighboring volcano of Vesuvius. The ruins of the city were rediscovered in 1748.

#### CHEMICALS AT THE CENTENNIAL.

##### THE AMERICAN EXHIBIT.

Not only does America occupy a great deal more space with her chemicals, as with nearly every thing else, than any other country, but the display is more gorgeous and imposing. Large and handsome, we shall see whether it possesses as much intrinsic value and excites as much deep scientific interest as that of Germany, directly opposite.

Powers & Weightman, of Philadelphia, make the finest display of all the manufacturing chemists. In a little palace erected in a conspicuous spot on the transept or cross aisle, they exhibit the costly medicinal alkaloids by the bushel, and poisonous ones in quantities sufficient to destroy a city. The most beautiful things, however, that they show are two large dishes of crystallized nitrate of ammonia, the salt from which nitrous oxide is prepared. Then come beautiful crystals of caffeine, of nitrate of silver, of tartaric and citric acids, and other more common substances. In the center of this little palace is a cake of crystallized alum, as tall, almost, as a man, with openings cut through to show the beautiful interior. But these exhibitors, we shall find, are not so far ahead in the display of alum as they are in some of the more costly but less showy specimens, like lithium salts, tannate and ferrocyanide of quinine, bromide and iodide of iron, monobromide of camphor, nitrite of amyl, nitrate of cerium, codeia, prussic acid, and opium and its alkaloids, with numerous salts of each. The display reflects great credit on the enterprising firm which sent it there.

The next display on the right of this is that of Rosengarten & Sons, of Philadelphia, second only in size to that before described, and like that deriving its chief interest from the large quantities of the alkaloids and their salts exhibited. We also noticed several rare preparations, such as iodide of manganese, subsulphate of iron, sulphocarbonate of potassium and of ammonium, etc.

Adjoining this, again, is a very prettily arranged exhibit of oils in numerous tall bottles on an elevated stand. They embrace natural, mineral, vegetable, and animal oils for commercial, chemical, and medicinal purposes, and are exhibited by F. S. Pease, of Buffalo, N. Y. Next follows a good display of camphor, by William F. Simes & Son, of Philadelphia, and near this again an exhibit of paints by Charles Moser & Co., of Cincinnati, O. And here we may note, in passing, that, from the very nature of the exhibit, paints and colors, if tastefully arranged, present a pleasing sight and attract more attention than almost any other in this department. This is particularly true of the exhibit of C. T. Reynolds & Co., of this city, well known from their customary display at the American Institute.

Directly opposite to Reynolds & Co.'s is the no less attractive display of Harrison Brothers & Co., of Philadelphia. In the center rises a tall pyramid surrounded by bright mineral colors. In a case near it is a pile of wood on which are arranged the products derived from the wood by dry distillation: pyroligneous acid, wood spirits, methyl alcohol, acetic acid, white, gray, and brown sugar of lead, charcoal, etc. Then come some bones, with a group of the necessary chemicals for converting them into home-made fertilizers. There too are beautiful lakes, paints for brickwork, moist colors for paper staining, and lastly white lead, with the best illustration that we have seen of the process of manufacture known as the "Dutch method." First we have the ore, galena; then the metallic lead cut into grates, or buckles, as they are technically called; then the pots, resembling ordinary red flower pots, with the grates in them; then a bed of tan bark, in which the pots are set while the conversion takes place; and finally pots as they come from the tan, filled with white lead, still preserving the shape of the original grates, and adhering loosely to the undecomposed lead within.

Another first class display of paints and varnishes is made by John Lucas & Co., of Philadelphia, Pa. It embraces, among other things, zinc ores, spelter, white lead pots, and buckles, sugar of lead, gums, kauri, dammar, copal, shellac, etc. They exhibit some bright green paints comparing very favorably with Paris green, but claimed to be free from arsenic. They have also fitted up a miniature laboratory with sink, wash bottle, test tubes, filters, funnels, etc.

The Brooklyn White Lead Works exhibit white lead and litharge, also a few pots and buckles. Wetherill & Brothers, of Philadelphia, exhibit red and white lead, litharge, and the like. Jemett & Son make the usual exhibit of white lead, as do also some others; but the above will, we think, be found to embrace the principal large exhibits of paints and pigments.

Nearly allied to the paints are the oils; but as they possess little or no novelty, we must pass them with mere mention. Gest and Atkinson, Cincinnati, O., draw attention to their exhibit of lard, tallow, and oils, by a large boar mounted above their case. Cotton seed oil is exhibited by Boyl & Lewis, Philadelphia. The petroleum oils are fairly represented by the Aladdin Company, of Pittsburgh, Pa., Elaine Oil Company, Charles Pratt & Co., Devos Manufacturing Company, Oleophena Oil Company, and others. Charles Pratt & Co., of New York, exhibit a model of their works at Hunter's Point, and specimens of petroleum and its various products. The model, which is on a scale of  $\frac{1}{2}$  inch to a foot, is very interesting, as showing not only the extent of these particular works—some eight acres—but as giving a faint idea of capital invested and machinery,

buildings, and apparatus required to make the Astral oil and other illuminating and lubricating oils.

The Elaine Oil Company exhibit, under the name of petrocene, a greenish, odorless, solid substance with crystalline fracture somewhat like paraffin. This, they state, is a new product of petroleum, and exactly what it is we are unable at present writing to say. In another place the same company have a working model of an oil well with a pump run by clockwork, and this conveys a good idea of this most important branch of American industry.

One of the best displays of alum is the alum cave exhibited by the Philadelphia Salt Manufacturing Company, Philadelphia. This immense cake of alum is said to weigh nine tons. In the same case is a large mass of cryolite, a fluoride of aluminum and sodium, chiefly imported from Greenland, this company having a monopoly of all the cryolite brought from there. They exhibit models of the Esquimaux fishing boats, and of the cabins built of blocks of ice and moss, the ice being represented in the model by blocks of wood. This company also exhibits alumina, alum lyes, chloride of calcium, and soda.

Directly opposite we see another beautiful alum cave, with its stalactites of crystals, and on either side tall monuments of concentrated alum and sulphate of alumina, while round about are large and fine crystals of nitrate of lead and other salts. These constitute the exhibit of the Tacony Chemical Works, Philadelphia.

If alum seems omnipresent in the chemical section, what shall we say of acetic acid and its salts that greet us at every turn? We have referred to it several times already in connection with other exhibits. Browning & Brothers, Philadelphia, exhibit pyroligneous acid and a series of acetates, as also dye wood and naphtha. H. J. Baker & Brothers exhibit this acid along with camphor, saltpeter, and borax. A prettier display is that of O. S. Follett, New York, of acetic acid, vinegar, chloroform, and fine large crystal masses of sugar of lead.

The Philadelphia Quartz Company make a good show of water glass, dry and in solution of various strengths, for different purposes. Its use in cleaning the cotton waste used for rubbing off machinery was forcibly illustrated by the exhibition of quantities of the waste before and after treatment with water glass.

The only exhibit of cream of tartar and argols that we saw was by the well known importers Dreyfuss & Co., New York. H. Bower, Philadelphia, exhibited the largest, if not the only, mass of crystallized ferrocyanide of potassium, also small specimens of sulphate of ammonia and the fatty acids. Savage, Keyser, & Stovell, of Philadelphia, exhibit tin salts and the mineral acids. H. D. Gray, of New York, was the only exhibitor of sulphur, which he imports and refines, our own immense sulphur deposits not yet being worked, although magnificent specimens of pure native American sulphur are to be seen in the United States Government building. When we shall be independent of Italy for our supply of sulphur is only a question of time and transportation.

Nickel salts, batteries, and specimens of nickel plating on iron, brass, and tin are exhibited here by Condit; but the display of nickel and cobalt with the ores and salts, by J. Wharton, in the metallurgical section farther north, is still more interesting.

There is no end of stale and uninteresting specialties distributed through this section, purely for advertising purposes; they are of no chemical value, although in some few cases a knowledge of chemistry has been invoked in their preparation. We refer to soaps, blacking, varnishes, perfumery, baking powders, mucilage, and printing and writing inks. The ink competition seems as lively as any, although one manufacturer claims to supply nine tenths or more of all the banks and offices, leaving a small field for other makers. Dr. J. S. C. Rowland, of Philadelphia, exhibits an indelible canceling ink which he claims has been adopted by the United States post office department. We omitted to mention last week an indelible black ink exhibited by Blackwood, John, & Co., London, under the name of jetoline. It consists of chloride of aniline, chlorate of potash, and chloride of the rare metal vanadium, and is in fact a kind of aniline black.

To return to the pharmaceutical and rarer chemicals, like those exhibited by Powers & Weightman and Rosengarten, we find in another part of the chemical section several very good displays. One of the largest, best mounted, and most interesting is that of Billings, Clapp, & Co., Boston, the manufacturers of the cinchoquinine which has been so much analyzed, and about which so many contradictory statements have been circulated. This firm exhibits two gallons of propylamine,  $C_3H_7$ , HHN, one of those organic ammonias in which an atom of hydrogen is replaced by the propyl radical  $C_3H_7$ , just as aniline,  $C_6H_5$ , HHN, is ammonia with one of the hydrogen atoms replaced by phenyl,  $C_6H_5$ , the radical of carbolic acid. The chloride of propylamine is shown in large quantities, as are also the more common salts such as bromide of ammonium, citrate of iron pure protocarbonate of iron, bromide of potassium and sodium, bisulphite of soda (for making the hydrosulphite) valerianate of zinc, and other salts used in medicine.

Charles T. White & Co., of New York, make a good exhibit of pharmaceutical chemicals, including some very fine crystals of strychnin, valerianate of quinine, and other alkaloids. Charles Pfizer & Co., also of this city, exhibit pharmaceutical and chemical products in large and showy quantities, including refined borax and camphor. Kurlbaum & Co., of Philadelphia, exhibit camphor, cream of tartar, chloroform, mercurial compounds, and the essential oils. The finest specimen of crystallized monobromated



camphor is that exhibited by Hance Brothers & White, of Philadelphia. The rest of their exhibit, extracts and pills, belongs rather to pharmacy than chemistry. The latter statement may apply in part to the exhibit of Keasbey & Mattison, of Philadelphia; but some of their preparations, such as pancreatine, pepsine, crab orchard salts, Vichy salt, and compounds of lithia and bismuth, all on a grand scale, attract our notice.

The exhibit of Alexander Fries & Brothers, of New York, of artificial fruit and liquor essences, is particularly interesting as showing how far the chemist in his laboratory is able to imitate the natural productions of the plant. The number is very large, most of them being compound ethers derived from methylic alcohol or fusel oil, and imitate not only the flavor, but the composition, of the natural essences. The same exhibit contains a large specimen of carbamide,  $\text{CO}(\text{NH}_2)_2$ , a white crystalline solid, which has the honor of having been the first organic substance produced synthetically, a thing previously supposed to be impossible. The United States Salicylic Acid Works, New York, exhibits the only specimen of American salicylic acid. The acid is both sublimed and crystallized, and compares favorably with the foreign specimens made under the immediate supervision of Professor Kolbe.

Aniline colors are exhibited by two firms only, and in such insignificant quantities as scarcely to deserve notice. The Silliman Chemical Works, of Philadelphia, exhibit six flasks holding about a quart each of as many different colored solutions of aniline dyes. The same company exhibit several other coal tar products, including the tar itself, dead oil, coke, benzol, toluol, xylol, rosolic acid, rosolate of lime, anthracene, and naphthaline: also a set of pure chemicals, designated in the catalogue as Fresenius' tests.

A much finer exhibit of coal tar products is made by Page, Kidder, & Fletcher, of this city. Besides the tar itself, they exhibit seventy-five different derivatives thereof, among which we noticed the latest product of the synthetic chemist, artificial oil of spirea or salicylic aldehyde. Professor Kolbe's discovery of a new and certain method of preparing salicylic acid cheaply from carbolic acid has caused chemists to direct attention to its ethers and other derivatives, the result being the production of artificial oil of wintergreen (also exhibited here), or salicylate of methyl, the substance which was previously the source of salicylic acid having come at length to be a product of the latter. In addition to these two new and curious synthetic products obtained from salicylic acid, we noticed the following rare and interesting scientific preparations: Benzylic aldehyde (oil of bitter almonds), pyrene ( $\text{C}_{16}\text{H}_{10}$ ), stilbene ( $\text{C}_{14}\text{H}_{12}$ ), chloranile, pyramic acid, pyridine ( $\text{C}_5\text{A}_5\text{N}$ ), picoline ( $\text{C}_8\text{H}_7\text{N}$ ), a substance isomeric with aniline yet of totally different properties, crude and refined anthracene, anthraquinone, alizarine, leucaniline, etc. A few aniline colors in small tubes are shown. One portion of this exhibit, and indeed the larger part, is devoted to creosote and its use in the preservation of timber. A model of the creosoting apparatus is shown; and numerous specimens, of wood decayed or bored by insects and wood protected by creosote, prove its efficiency.

J. Bishop exhibits a large variety of costly platinum utensils for chemical use.

E. B. Benjamin, of New York, exhibits a few chemicals, with some fine chemical glassware, in the educational department, and also in the United States government building. In his exhibit in the Main Building may be seen two of those new scientific puzzles called radiometers, which are usually in motion on a clear day, a fact not equally true of the dozen or more exhibited in the English department, by Mr. Hicks, of London.

In the exhibit of the Stevens Institute of Technology, Hoboken, may be seen a large dish of beautifully crystallized nitrate of uranium, and a full set of the other uranium salts used by President Henry Morton and Dr. H. C. Bolton, in their recent researches on the fluorescent spectra of these bodies.

There are several exhibits of gunpowder, but none of nitrolycerin, although there are plenty of the harmless materials from which it is made.

A few chemicals are met with scattered about in most unexpected places, especially in the United States government building, but the above embrace the most interesting exhibits in the Main Building.

CENTENNIAL NOTES.

A THREE HUNDRED DOLLAR HAT.

There are two exhibits in the Peruvian section which attract an unusual share of attention. The first is the hideous collection of mummies and fragmentary portions of the bodies of ancient Peruvians; and the second is what appears to be an ordinary Panama hat, until the sight of the price label, inscribed \$300, induces one to examine it more carefully. Close scrutiny elicits the fact that the article is woven with wonderful fineness; and by the aid of a lens, 108 stitches, or picks, as weavers would call them, may be counted to the inch, measured radially from the center. The hat is exhibited by Juan Daste, of Monte Christo, Peru. The material is *jipijapa*, a species of palm, the leaves of which are gathered before they unfold. After the veins and other coarse portions are removed, the leaves are made into bundles and macerated in boiling, and then in cold water until they become white. Bleaching in the shade follows and then the hats are plaited from the straw by the Indian natives of the country. For so fine a fabric as the hat exhibited at the Centennial, the above process would be too rough. The only wetting the straw receives is done by

the dew, to the influence of which it is exposed. Then the braiding is done in a dark damp room; and to produce a single hat, a woman often works from five to six hours daily for three or four months. When the article is finished it will wear indefinitely, provided there be no defective straws in it. Probably the \$300 hat exhibited in Philadelphia would outlast the lifetime of its purchaser, and serve as an heirloom to his descendants for years afterward.

FLEXIBLE SHAFTING.

Imagine a workman handling the nozzle of a short section of hose. In place of the nozzle, substitute an auger; and then conceive the astonishing appearance of the man directing the auger toward a block above his head, then to the floor, then sidewise in every direction, twisting the hose meanwhile into all sorts of kinks and curls, while the tool, wherever it touches, sinks into the solid material as if the latter were putty. Yet the hose does not rotate. Certainly the invention is a remarkably ingenious one, and it is as simple as it is effective. A long section of wire is made into a close spiral. Over this is wound more wire, the turns being, however, in reverse direction; then follows a third spiral envelope, and so on until suitable thickness is attained. The extremities of the flexible shaft thus formed are brazed. One end is feathered into a driving pulley; the other has a clutch for the tool. A piece of hose or other suitable covering envelopes the shaft, which transmits rotary motion to any desired distance from the source of power and through any number of curves, so that the power may be taken to the work instead of the work to the power. We were told that the device has been successfully applied to marble, granite, and other stone surfacing, polishing, and working; iron drilling and surfacing; wood boring, carving, and facing; horse cleaning and clipping; casting, cleaning, and emery grinding of all kinds. It has been tested, we learn, up to the transmission of 9 horse power.

A NEW STEERING APPARATUS.

This is exhibited in the Russian section in Machinery Hall, and is the invention of M. Nozikoff. The helm being located directly above the propeller shaft, motion is communicated from the latter by a bevel gear to a vertical shaft, which rises immediately abaft the wheel. By turning the latter in one or the other direction, one of two clutches is thrown into action, the effect of which is to communicate the motion of the vertical shaft to an ordinary hand wheel which moves the rudder in the usual way. The essential feature of the device is the mechanism whereby the power of the main engines is utilized to manoeuvre the helm, thus obviating the use of the additional small engine commonly employed in steam steering gear for a like purpose.

A PAINTING MACHINE.

Everyone who has had to paint slats or laths, or like narrow work, knows that doing so is a tedious and not over easy operation. Plenty of paint is wasted in using a big brush, and to employ a small one is to throw away time. Mr. W. Roberts, of Liverpool, exhibits, in the English section of Machinery Hall, a very ingenious little apparatus which performs this work very rapidly and in a much better manner than it could be done by hand. The paint is poured into a lower tray. Above are located, first, a pair of rollers, which seize the slat and draw it in between a series of brushes, one of which paints the upper side, another the lower side, while two more cover the edges. To keep these brushes wet with paint, two wheels beside the grasping rollers rotate partially in the paint in the tray beneath. These are so grooved as to carry up the liquid at every revolution and dash it on the brushes. The machine, we learn, will paint 6,000 running feet of lath per hour, without the aid of steam power.

SWEDISH GYMNASTIC APPARATUS.

We can express no opinion as to the therapeutic value of the Swedish movement cure, other perhaps than to consider that the exercise which it provides for the muscles may be beneficial. We can express an opinion, however, on the machines employed in the various gymnastic exercises, a dozen or more of which are exhibited in Machinery Hall. Some of these are splendidly constructed; and as pieces of mechanism involving ingenious devices for obtaining odd motions, they are well worthy of study by mechanics. Some idea of what these motions are may be gained from the following brief description of the apparatus: One machine, when its handles are grasped by the patient, twists the arms, another exercises the flexor and extensor muscles of the wrist, a third pulls the arms back, a fourth exercises the knee muscles, a fifth exercises the muscles which carry the leg outward, and a sixth exercises the ankle muscles. On the seventh the patient lies down and is shaken up so that the extensor muscles of the back are exercised. Another machine is very complicated, and calculated to excite some dismay in the patient whose "thorax" (to quote the descriptive card) "is pulled upward by means of two levers, while a pad makes a horizontal pressure on the back. The trunk is thereby elongated a few inches, and the spine and walls of the chest are stretched." There is something about all this dimly suggestive of the rack. In another machine the patient is put through all the misery of horseback riding without any of the accompanying pleasures. He is seated on a saddle, and the latter then becomes possessed of a desire to shake him off. "This," we are informed, "causes the abdominal viscera to be kneaded and rubbed together against each other and the abdominal walls." There is still another machine, consisting of a couple of wheels having peripheries of padded bars. These, when revolved, serve to warm the feet, the latter being pressed against them. Lastly there is a hammering machine, which in any household might serve

as a mechanical child corrector. There are a number of vertical beaters which are set in rapid vibration, so as to hammer the patient in the small of the back or at any desired point. The reader can form his own idea of the possible condition of the sufferer after being treated by so formidable a series of apparatus.

Recent American and Foreign Patents.

NEW MECHANICAL AND ENGINEERING INVENTIONS.

IMPROVED TUBING CHAIN WRENCH.

Orlando H. Smith, Kane City, Pa.—The object of this invention is the construction of a device whereby a section of the perpendicular tubing, such as that of oil wells, may be turned more or less on its axis, without danger of being cut, dented, bruised, or otherwise injured. The invention consists in joining together, by a reversible dog, a chain and hook; the latter, which is for the purpose of maintaining the hold of the chain on the pipe, has its point formed into an inwardly projecting claw, and is provided near the middle of its concavity with a slightly projecting blunt point. These projections form two of the bearing points against the tube over which the hook rests; the third is formed by the edge of the dog. To the free end of the chain is secured a ring, into which a lever is inserted when the device is to be used.

IMPROVED GRAIN CAR UNLOADER.

George M. Moulton, Chicago, Ill., assignor to himself and Joseph T. Moulton.—This apparatus is for unloading grain in bulk from railroad cars; and it consists in the employment of two sets of racks, so arranged that the first rack is operated by a crank placed on a shaft which receives its power from a convenient motor, the said rack giving motion to a pinion placed on a shaft which supports a larger wheel, that communicates a reciprocating motion to a longer rack supported on suitable frame work, and connected with drag ropes attached to scoops within the cars. The invention also consists in the peculiar arrangement of the supports for the guiding pulleys in the car. A hopper leads to the elevator leg, and is placed conveniently near the track, so that the grain may be readily discharged from the scoop into it. Two scoops are worked in each car, and a number of cars may be unloaded at the same time, and from both sides of the apparatus, by providing a number of sets of drag ropes.

IMPROVED BREECH-LOADING FIRE ARM.

Henry J. Altman, Birmingham, Great Britain.—This invention consists in a breech block, arranged to slide in grooves in the solid slides of the breech piece at right angles with the bore of the barrel, as it is carried up and down by the breech block holder. The arrangement of the lock lever is such that an accidental blow that might discharge the gun only pushes the lower end of the lock lever back and locks the trigger. Another advantage claimed is that, when the trigger is locked and the fore finger is placed upon it to discharge the arm, the said finger comes in contact with the lock lever, and can push it forward to unlock the trigger without being removed from the position required for firing the arm.

IMPROVED WATER WHEEL.

William H. Rector and Henry C. Black, Santa Rosa, Cal.—This invention consists of a reaction wheel of the S-shaped type, receiving water from the under side, and having a water tank or chamber on the shaft, subject to downward pressure of water to counterbalance the upward pressure on the under side. The chamber is packed watertight to prevent leakage.

IMPROVED NUT LOCK.

Thomas C. Conrad, Philadelphia, Pa.—This invention is an improved nut lock for rail joints, and other parts exposed to vibratory motion, the nut locks being so arranged and connected that the tendency of any one nut to work off tightens the other nuts, and that the expansion and contraction of the bolts, and change of position in the ends of rails by the difference in temperature, exert no influence upon the lock. It consists of a washer with recess for the nut to fit in slots in the circumference, and a circumferential recess at the backs, along which a stiff locking wire is passed that is bent outwardly through the top slot, and then downwardly to the next washer, and around the same to the top slot, and so on.

IMPROVED NAIL-FEEDING MACHINE.

Frank Toepfer, Milwaukee, Wis.—This invention consists of a descending trough, in which the nails hang by the heads, points downward, arranged so as to drop the nails horizontally into a hopper in advance of the sliding driver. The driver is to be worked by a foot treadle, and, in practice, a number of drivers, each having an automatic feeder, will be connected to a cross head or slide of suitable form to work as many drivers as there are nails to be driven into one side of the box to be nailed, and the drivers will be adjustably connected for shifting toward and from each other, according as the nails are to be driven more or less distant from each other.

IMPROVED STEAM BOILER.

Robert M. Beck, Westminster, Md.—This invention is an improvement in the class of vertical steam boilers, and consists in a dome, flue head, and smoke box formed of one casting, and certain peculiarities of shape, whereby certain functional and economic advantages are attained. The invention also relates to a tapered cast iron fire box.

IMPROVED CAR COUPLINGS.

Richard A. Kelly, Manchester, Iowa.—The first of these inventions is an improvement in the class of automatic car couplings, and consists in a hook and draw bar pivoted at their rear ends to a swiveled cross bar, and suspended free at their front ends from a sway bar or lever which is pivoted to the end of the car, so that it may be tilted to adjust the hooks and draw bars, for coupling or uncoupling. The invention also includes a peculiar device for adjusting the said sway bar. The second invention belongs to the same class of automatic car couplings as the above, and it relates to certain peculiarities in the coupling whereby ease in working and reliability and safety in its operation are obtained.

IMPROVED WATER WHEEL.

Reuben D. Sayre, Westville, Ohio.—This invention consists of the buckets of an overshot or breast wheel, pivoted to the wheel rims so as to remain upright and hold the water until the center is reached at the bottom, when they are tilted by a cam to empty the water, by which the wheel retains all the water as long as it can do any good, and the weight can be applied farther from the center of the wheel by pivoting the buckets at the periphery of the wheel rims. The buckets are pivoted to the wheel rims at or near the periphery so as to remain upright and hold all the water as long as it is efficient, when they are tilted by a crank and cam and the water emptied, after which they return to the upright position again while ascending to the place for receiving the water, the cam being continued up to the top to prevent the buckets from tilting too far to come back again to the upright position. In front of each bucket is a cross bar, to prevent it from being overturned by the water falling into it from the spout. In practice, the cam for tilting the buckets will be constructed so as to revolve, to lessen the friction as much as possible.

#### IMPROVED COMBINED PRESSER FOOT AND THREAD CUTTER FOR SEWING MACHINES.

John M. Stamp, Washington, D. C.—The various forms of thread cutters heretofore applied to the presser feet of sewing machines have proved objectionable, for various reasons, chief among which are a too complicated and expensive construction, and such a location or arrangement as renders them inconvenient in use. The object of this invention is to provide a presser foot with a thread cutter, which shall be so constructed as to obviate these and certain other objections; and to this end a vertical cutter is attached to or formed on the left hand side of the presser foot, near the toe or front end thereof. The device is cheap, simple, and conveniently located.

#### IMPROVED AIR MOTOR.

Benjamin F. McKinley, New Richmond, Ohio.—This invention relates to a novel construction of an engine to which has been applied the name of "thermainator," the same being designed to utilize the alternate pressure and partial vacuum produced by the alternate heating and cooling of the same body of air. It consists mainly in the combination with a working piston moving in a cylinder, of a cylinder made entirely of woven wire, without a shell or case, operating consecutively with the working piston, and located in a chamber communicating with the cylinder of the working piston and between the working piston and the surface through which the heat is applied.

#### IMPROVED BALE TIE.

Willis Wilkinson, Charleston, S. C.—This invention is formed of a wire having a hook formed upon one end, to receive and support the other end when the band is under strain.

### NEW AGRICULTURAL INVENTIONS.

#### IMPROVED FEEDER FOR THRASHING MACHINES.

Jesse W. Dozier, Nashville, Tenn.—This invention relates to an improvement in feeders for thrashing machines by which the quantity of grain supplied to the cylinder is automatically regulated.

#### IMPROVED SEED PLANTER.

Peter Kranz, Arago, Neb.—This seed planter is so constructed that it may be adjusted to operate as a self-dropper or as a hand dropper, and may be adjusted to drop the hills at different distances apart, and to drop any desired amount in a hill. The frame of the rear part or carriage rides upon the axle, on which the wheels revolve, and their rims are made wide, and are concave to adapt them for covering the seed. To the inner sides of the wheels are attached pawls, which engage with the teeth of the ratchet wheels attached to the axle, so that the wheels may be made to carry the axle with them when desired. The forward ends of the side bars of the frame are connected with the rear cross bar of the frame of the forward part of the machine by clevises and eyebolts or other suitable hinges. To the rear corners of the forward frame are attached the seed hoppers, to the bottoms of which are attached ring plates upon which a dropping wheel rests and rotates, and in the rear part of which is formed a slot for the passage of seed from the dropping wheel to the conductor spout. Through the center of the dropping wheel is formed a hole to receive the upper end of the spindle, which passes down through, and is swiveled to, the bottoms of the hoppers. When the machine is adjusted as a self-dropper, the dropping wheel must be keyed, or otherwise rigidly secured, to said spindle; but when adjusted as a hand planter, the said dropping wheel may be allowed to revolve loosely upon the said spindle.

#### IMPROVED COTTON CLEANER.

Amos J. Lee, Lineburg, Ala.—This apparatus consists of a kind of long trough or case, with a bottom of longitudinal slats or grates, and sides of vertical or inclined grates or slates, in which trough is a shaft having paddles arranged obliquely and in spiral rows around the shaft for beating the cotton out, and at the same time feeding it along from the end in which it is supplied to the end for discharging it, the same being a very efficient contrivance, which does not clog or twist the material; but the paddles generate a considerable amount of wind, which drives out all dust and dirt through the openings between the slats.

#### IMPROVED MANURE WAGON.

Jason W. Town, South Woodbury, Vt.—This wagon has its bottom formed of parallel bars arranged sufficiently closely together to prevent escape of the manure while being transported to the field, and yet at such distance apart as will allow the discharge of the manure when the bars are rotated. In using the wagon, it is loaded and drawn to the place where the manure is to be spread. A lever is then operated to throw wheels into gear, so that, as the wagon is drawn forward, rollers may be revolved to pulverize the manure and work it out through the bottom of the wagon, spreading it evenly over the surface of the ground.

#### IMPROVED PORTABLE FENCE.

Strander Crum, Macon, Mo.—This invention relates to certain improvements in portable wooden fences; and it consists in jointed A-shaped frames combined with bars arranged upon the outside of one of the inclined sides of the frames, so as to alternate with each other, together with a binder which is arranged parallel with one of the stakes of the frames, and upon the outside of the bars so as to hold them in place, which binder is fastened below by a pin driven in the ground, and above by a pin driven into the stake.

#### IMPROVED METHOD OF ATTACHING HARROW TEETH.

Christoph Schottler, Greenville, Wis.—This invention consists in fitting the tooth, which is long, tapering, and with a square transverse section, into a similarly shaped vertical groove on the side of the harrow beam. The tooth passes above and below through holes in the ends of a semicircular metallic strap, which is keyed on the side of the beam opposite the tooth by a key of the shape of half a frustrum of a cone.

### NEW MISCELLANEOUS INVENTIONS.

#### IMPROVED SKATE.

John A. Dodge, Amherst, Nova Scotia.—This invention is a skate so constructed that it may be easily and quickly attached to, and detached from, the boot of the skater, and when attached will be securely held.

#### IMPROVED COMPOSITION PASTE FOR FLY PAPER.

John Ralston, Greenville, Pa.—This improved sticky fly paper paste is put up in boxes, so that it can be spread upon paper by the user, will always be fresh, and it is claimed, much less expensive than the ordinarily prepared paper. The invention consists in a paste, formed of flaxseed oil (but various other oils may be used), Venice turpentine, and rosin.

#### IMPROVED FRUIT DRYER.

Andrew M. Mortimer, Salt Lake City, Utah Ter.—This is an improved apparatus for drying fruit in the sun, so constructed that the fruit may be easily covered and protected in stormy weather. The dryer may be conveniently adjusted into such positions as will best expose the fruit to the sun's rays.

#### IMPROVED HARNESS PAD.

Hibbard R. Ridgley, George A. Nelson, and William H. Bushnell, Haysville, Ohio.—The rim which forms a part of the pad has an offset, provided with imitation stitches, giving it the appearance of having been stitched together.

#### IMPROVED HARNESS SADDLE.

P. S. Carroll, Louisville, Ky.—This invention consists in making each side of the back strap of two parts, the upper one of which is fastened to the saddle tree and flap, and to an inner stay or spring by the terret screw, which is secured inside by a nut. The two parts of the back strap, on each side, are joined by a metallic fastener provided with rivets on its under surface, and a ring on its lower end: the former securing it to the upper part of the back strap, saddle flap, and inner stay or spring, the latter for the attachment of the lower part of the back strap.

#### PACKING CASE FOR CRACKERS AND CONFECTIONERY.

Joseph Garneau, Sr., St. Louis, Mo.—This invention consists of a main case and a sample case, the latter being provided with a transparent side, of glass or other improved material, and being detachably connected to one side of the main case by an extension thereof at the bottom and the cover, the sample case corresponding in length and breadth with the side of the case.

#### IMPROVED REED ORGAN TREMOLO.

Henry L. Pierce, Easton, Pa., assignor to himself and Samuel Trumbore, of same place.—The first part of this invention consists in an arrangement of a propelling wheel having curved blades, and a governor consisting of a piston attached to a valve in such a way that the pressure of air acting on the piston controls the jet of air which propels the wheel. The second part consists in a cut-off of peculiar construction, which is rotated by the propelling wheel. The vacuum in the organ bellows is more or less perfect, according as more or fewer exertion is made on the pedals or blowing lever, or as more or fewer of the keys are opened. Under these circumstances the piston acts as a governor, maintaining a uniform rate of speed. When the tremolo attachment is in use, the entire current of air which goes into the bellows may be allowed to pass through it, or by an arrangement of stops the tremolo may be made to affect certain portions of the reeds. The cut-off breaks the current of air twice at every revolution. The advantages claimed are that the governor maintains a uniform rate of speed whether the air passes into the bellows with greater or less force. The curved veins in the propelling wheel insure a positive and uniform action. The cut-off, by stopping the in-going current of air at small intervals, produces the tremulous effect which is so necessary to the complete rendering of certain kinds of music.

#### IMPROVED HEATER FOR CARS, ETC.

Milton W. Hazelton, Chicago, Ill., assignor to himself and Anson W. Eggleston, of same place.—This heater consists of two cases of metal or other suitable substance, placed one within the other, so as to form a space between them, except at the top, which is filled with asbestos or other non-conducting material, and is charged with hot balls or other form of metal, for heating the car or other room by radiating the heat contained in the said objects; and in the top of the heater is a register, and in the bottom an opening for allowing the air to flow in to be heated and be discharged at the top, by which the heat may be given off more or less rapidly, according to the volume of air allowed to pass, which can be regulated at will by the register. The register may be in the inlet passage, if preferred. The heater is designed mainly for cars and carriages; but it may also be used for heating rooms, temporarily, in hotels. The hot balls will be supplied to the cars at the stations, and may be introduced through a door in the top or side, as preferred. For street cars the heater will preferably stand on the floor like a stove; but for railway cars it may be let down from the floor, and the balls may be put in at one side or end under the floor of the car.

#### IMPROVED ICE CREAM FREEZER.

David J. Rogers, Bardstown, Ky.—This invention has reference to that class of ice cream freezers which consist of a can pivoted upon a step in the bottom of the tub or pail, and are adapted to be rotated to effect the freezing without any internal stirrer. The present improvements consist in the particular construction and arrangement of a rim attached to the tub, which holds the can in an upright position, and also in the construction and arrangement of the handle.

#### IMPROVED PEANUT ROASTER.

Jean Esposito, New York city.—This peanut roaster is provided with a hot water chamber, arranged vertically in the case above the draft passage, and between the roaster and storage chamber. The peanuts are transferred, after being roasted, directly to the storage chamber, to be sold in warm and nice state, without keeping them too long in the roasting drum, to become dry.

#### IMPROVED CAMP KETTLE.

Antoine Alexis Gervais, Paris, France, assignor to A. Gervais & Co., of same place.—This invention is designed, says the inventor, to remedy the defects of camp kettles in present use, which in fair weather require about three hours, at least, for making soup, and this only by a considerable expenditure of fuel, while in rough weather the fire is liable to be extinguished. By the improvement a considerable saving in fuel is insured, and much less time is occupied in cooking, whatever may be the state of the weather. A number of these kettles may be combined so as to have two, three, or more draft chimneys with a single tunnel running beneath the whole series of kettles, which are placed over a trench made in the ground.

#### IMPROVED BILLIARD CHALK AND BALL HOLDER.

Rafael Martinez, New York city.—This cue-chalking attachment for billiard tables consists of a little case for holding the chalk, combined with a billiard ball holder, the case having one end contrived to open and close for putting in and adjusting the chalk, and having one or more holes through the side for inserting the cue tips against the chalk. A stud or key prevents the chalk from turning while the case is closed. The case is attached to the table at any place, so that the player can at any time chalk his cue tip without taking the chalk in hand, also without scattering it on the floor.

#### IMPROVED POCKET KNIFE.

Amos W. Coates, Alliance, Ohio.—This invention relates to an improvement in pocket knives of the kind ordinarily used by boys; and it consists, as a new article of manufacture, in a pocket knife having a blade extended beyond the handle and formed with a knob of metal upon the end thereof to prevent accidental injury resulting from the careless or thoughtless use of the knife.

#### IMPROVED MANUFACTURE OF LIME AND CEMENT.

Uriah Cummings, Buffalo, N. Y.—This invention relates to the manufacture of lime and cement, so that neither too high nor too low a temperature may be employed, and consists in blowing with a force pump air and hydrocarbon into the furnace simultaneously, so as to bring them in contact with the stone when at a red heat and subsequently, thus producing a perfect combustion, a great economy of fuel, and a more uniform as well as a better article.

#### IMPROVED SADDLE.

John T. Gathright, Louisville, Ky.—This invention consists essentially in providing the tree of a gentleman's saddle with attachments for horns and a supplementary seat, the former fitting over the pommel of the same, and being strengthened by the necessary re-enforcements. These attachments may be so constructed as to be used with gentlemen's saddles of any shape and style.

#### IMPROVED CORSET.

Catharine A. Griswold, New York city.—The object of this invention is to so improve the corset for which letters patent have been granted to the same inventor, under date of July 4, 1871, No. 116,585, that the same may be made available for imparting better carriage to the upper part of the body, and prevent, by strengthening the back and bracing the shoulders, the inclination to stoop and contract the chest.

### NEW HOUSEHOLD INVENTIONS.

#### IMPROVED MOP HOLDER.

John W. Cabbage and John Alexander, Gallipolis, Ohio.—In this device the handle has a wire secured to it and bent twice at right angles, with arms that pass through holes in the ends of a plate or clamp bar. The arms of wire or clamp rod are bent inward as well as upward, and their ends are attached to a socket. Through the latter passes the end of the handle, the socket being secured thereto by a hand screw. The cloth is placed between the middle part of the clamp rod or frame and the clamp bar, the handle being then inserted in the socket or sliding head, and its end pressed down against the clamp bar. This clamps the cloth very securely between the bar and rod, while, the clamp screw being then tightened, the parts of the mop head are locked together.

#### IMPROVED CLOTHES DRYER.

Orlando B. Lee, Greenville, Conn.—This invention consists in the peculiar devices which are used in holding the sides of the frame together, the object being to furnish in a clothes dryer such connections for the top or sides of the parts of the dryer as will permit them to be readily attached and detached.

#### IMPROVED WRITING DESK.

Jerome M. Keys and Homer J. Taylor, Tecumseh, Neb.—This invention is a writing desk for business purposes, having greater capacity for the space occupied, and being more convenient for use than the desks as ordinarily made. It consists of a case of hexagonal form, or any equivalent form will do, with a writing table in each alternate side, which slides out and in, and has pigeon holes and other repositories on the back part to be brought forward for convenience when the table is pulled out for use, the said tables being closed in with circular covers. Above the case is a tower of similar form containing two or more revolving book racks, one above another, for convenience in taking down and putting away the books.

#### IMPROVED EVAPORATOR FOR REGISTERS.

W. R. Fowler, Baltimore, Md.—This invention consists in moistening hot air as it passes into an apartment from a furnace or stove by causing it to pass through strips of absorbent material more or less saturated with water. The absorbents are endless pieces of fabric, held by opposite rolls and dipping into the water being spaced by ring grooves in the top roll. The invention is equally adapted to any form or location of register, by means of an attachment, open at bottom so as to enclose with a lid the ordinary floor register, and provided with a rear opening to correspond with that of the evaporator.

### NEW WOODWORKING AND HOUSE AND CARRIAGE BUILDING INVENTIONS.

#### IMPROVED SLED.

James L. Brannock and James A. Cleveland, Antioch Mills, Ky., said Cleveland assignor to said Brannock.—This invention is an improved runner for sleds and sleighs, which saves a great deal of the time and trouble necessary to put in the ordinary sole or runner. It consists of a separate curved front part that is connected to the main body of the runner in rigid manner.

#### IMPROVED EXTENSION STEP LADDER.

Wilhelm H. Bitter, Fort Howard, Wis.—In this invention, the several parts of a step ladder are made of such form that, while it may be used as a step ladder in the ordinary way, it may also be unfolded and extended, and used as an ordinary ladder. It is composed of three sections, two of which are capable of extension by sliding one upon the other, and a third section, which is hinged to one of the sliding sections, which is capable of unfolding, the whole being provided with hooks for uniting two or more ladders.

#### IMPROVED MACHINE FOR SAWING LATHS.

John W. Calkins, Avoca, N. Y.—This invention consists of a mandrel carrying a number of saws, separated the required distance by washers, and a frame for supporting the same, with a friction roller, placed in the table, over which the saws run. The advantages claimed for a board grooved or formed into a series of connected laths are that it may be more rapidly applied to the walls and ceiling of a building, that it produces a more solid wall and ceiling, and that it does away with sheathing.

#### IMPROVED PLASTERING TOOL.

Asa A. Howe, Ulysses, Pa.—This invention consists of a kind of box with open top and hinged bottoms, and also guides on two sides, the said bottom being two smooth steel plates, which overlap each other at the uniting edges, and are raised toward the upper side of the box to make a cavity in the lower side, which is filled with mortar to spread on the wall by sliding the tool along the wall, and at the same time pressing the bottom by a handle attached to one of the parts, so as to force the mortar on to the wall, and spread it smoothly as the tool moves along. The handle is adjustable along the brackets, according to the leverage it is desirable to employ in pressing the plaster on the wall.

#### IMPROVED SHAVINGS SEPARATOR.

Elijah Brown, New York city, assignor to himself, Eben Peek, and Gilbert J. Bogart, of same place.—This invention is for separating the finer from the coarser shavings made in planing mills and other woodworking machines. It consists of a screen hung in an inclined position upon two sets of swinging arms, and provided with a divider or frame carrying a number of cross wires a short distance above the screen. The screen is arranged to take motion from a crank driven by any convenient power, and the divider is arranged to move with the screen, but through a greater space, constantly shifting its position in relation to the screen.

#### IMPROVED STENCH TRAP.

John Peter Schmitz, San Francisco, Cal.—This is an improved construction of stench trap, designed more particularly for wash basins and sinks, but applicable also to general use. It consists mainly in combining with the ordinary water trap a subjacent flap trap, or weighted valve, which remains closed until its weight is overbalanced by the greater weight of water, when it opens automatically and allows the water to escape; by means of which arrangement the bubbling up of sewer gas through the water trap is prevented by relieving the water trap from the pressure of the same.



Business and Personal,

The Charge for Insertion under this head is One Dollar for each insertion. If the Notice exceeds Four Lines, One Dollar and a Half per Line will be charged.

Dry Steam, the only fit Lumber, Fruit, Tobacco, Dryers. Ask free. H. G. Bulkley, Cleveland, O.

Agricultural Implements and Industrial Machinery for Export and Domestic Use. R. H. Allen & Co., N. Y.

First class Draughtsman and Mechanic is open for engagement; accustomed to design special tools. P. O. Box 80, New Haven, Conn.

A Canada Patent for Sale at a Bargain—(Door Mat and Brush). For particulars, address O. Rice, Adrian, Ill.

Open for Special Bargains, light goods, any kind. I. Kinney, London, Canada.

Jack Screws—The Patent Right for the simplest and best Jack Screw for Sale. W. B. Alden, 477 Tremont St., Boston, Mass.

Every Mechanic should send for "Wrinkles and Recipes." Price \$1.50. Address H. N. Munn, Box 773, New York P. O.

For Sale—A Second-hand Daniels Planer, good as new, Ball's make. Planes 18x25 and 16 feet long. Price \$150. F. A. Sinclair, Mottville, N. Y.

To stop leaks in boiler tubes, use Quinn's Patent Ferrules. Address S. M. Co., So. Newmarket, N. H.

Model Makers, send address to Knight & Knight, Washington, D. C.

Water, Gas, and Steam Pipe, Wrought Iron. Send for prices. Bailey, Farrell & Co., Pittsburgh, Pa.

Circular Saw Mills of the celebrated and popular "Lane" pattern, made under direct supervision of inventor by the Lane M'f'g Company, Montpelier, Vt.

Shaw's accurate and U. S. Standard Mercury Gauges, Steam, Vacuum, Hydraulic, and Test Gauges. &c., 915 Ridge Avenue, Philadelphia, Pa.

A Scraper Patent for Sale. Address R. Vere, 88 Wall St., New York.

Solid Emery Vulcanite Wheels—The Solid Original Emery Wheel—other kinds imitations and inferior. Caution.—Our name is stamped in full on all our best Standard Belting, Packing, and Hose. Buy that only. The best is the cheapest. New York Belting and Packing Company, 37 and 38 Park Row, New York.

Glass Blown Cylinders. T. Degnan, 129 Milk St., Boston, Mass.

Models for Inventors. H. B. Morris, Ithaca, N. Y.

M. Shaw, Manufacturer of Insulated Wire for galvanic and telegraph purposes, &c., 259 W. 27th St., N. Y.

F. C. Beach & Co., makers of the Tom Thumb Telegraph and other electrical machines, have removed to 530 Water Street, New York.

Pat'd Graining Stencils—J. J. Callow, Cleveland, O.

Lathe Dogs, Expanding Mandrels, Steel Clamps, &c., for Machinists. Manufactured by C. W. LeCount, So. Norwalk, Ct. Send for reduced Price List.

Driving Belts made to order, to accomplish work required. Send full particulars for prices to C. W. Army, 148 North Third St., Philadelphia, Pa.

Clapboard Machinery—Sawing, dressing, and trimming—a specialty of the Lane M'f'g Company, Montpelier, Vermont.

Hand Fire Engines, Lift and Force Pumps for fire and all other purposes. Address Rumsey & Co., Seneca Falls, N. Y., U. S. A.

Handbook of Useful Information for Lumbermen, Millwrights, and Engineers (152 pages) sent free by Lane M'f'g Company, Montpelier, Vermont.

More than Ten Thousand Crank Shafts made by Chester Steel Castings Co., now running; 8 years' constant use prove them stronger and more durable than wrought iron. See advertisement, page 221.

See Boulton's Paneling, Moulding, and Dovetailing Machine at Centennial, B. 8-55. Send for pamphlet and sample of work. B. C. Mach'y Co., Battle Creek, Mich.

"Dead Stroke" Power Hammers—recently greatly improved, increasing cost over 10 per cent. Prices reduced over 20 per cent. Hull & Belden Co., Danbury, Ct.

Lane's "Monitor" Turbine Water-Wheels are not perpetual motion machines, but they combine more and greater advantages than any other water motors offered the public. Address Lane Mfg Co., Montpelier, Vt.

Power & Foot Presses & all Fruit-can Tools. Ferracute Wks., Bridgeton, N. J. & C. 27, Michy, Hall, Cent'l.

Shingles and Heading Sawing Machine. See advertisement of Trevor & Co., Lockport, N. Y.

Steel Castings, from one lb. to five thousand lbs. Invaluable for strength and durability. Circulars free. Pittsburgh Steel Casting Co., Pittsburgh, Pa.

For best Presses, Dies, and Fruit Can Tools, Bliss & Williams, cor. of Plymouth and Jay, Brooklyn, N. Y.

engineer of distinguished ability and extensive practical experience. Enquiries relating to electricity are answered by one of the most able and prominent practical electricians in this country. Astronomical queries by a practical astronomer. Chemical enquiries by one of our most eminent and experienced professors of chemistry; and so on through all the various departments. In this way we are enabled to answer the thousands of questions and furnish the large mass of information which these correspondence columns present. The large number of questions sent—they pour in upon us from all parts of the world—renders it impossible for us to publish all. The editor selects from the mass those that he thinks most likely to be of general interest to the readers of the SCIENTIFIC AMERICAN. These, with the replies, are printed; the remainder go into the waste basket. Many of the rejected questions are of a primitive or personal nature, which should be answered by mail; in fact hundreds of correspondents desire a special reply by post, but very few of them are thoughtful enough to enclose so much as a postage stamp. We could in many cases send a brief reply by mail if the writer were to enclose a small fee, a dollar or more, according to the nature or importance of the case. When we cannot furnish the information, the money is promptly returned to the sender.

B. F. R. will find a recipe for marine glue on p. 43, vol. 32.—C. S. will find a description of bisulphide of carbon on pp. 306, 368, vol. 28.—W. R. will find directions for making gas from coal oil on p. 65, vol. 32.—R. W. can make sulphate of indigo by the process described on p. 250, vol. 34.—J. K., B. L., H. T., W. H. N., T. W., J. M., M. B., and others who ask us to recommend books on industrial and scientific subjects, should address the booksellers who advertise in our columns, all of whom are trustworthy firms, for catalogues.

(1) T. C. D. asks: Is not the velocity of a rifle ball greatest at the moment when it leaves the muzzle? A. Yes.

(2) C. G. B. says: In setting valves on a locomotive I differ from a master mechanic. In squaring valves, I heretofore observed (after finding the dead centers on the wheels in the usual way, and adjusting the eccentric rods with the reverse lever thrown clear forward or back, and on those points giving the proper lead) that, by hooking the lever up say to 12 inches, at times the valves do not show square at that point, and the rods may have to be changed. I still work from my center on the wheels. The master mechanic says that, on some engines, valves cannot be squared in that way. He does not use the center on the wheels at all, when the lever is hooked at 12 inches, but measures 12 inches on the guides, and there squares the valves. Working my way, the valves showed  $\frac{3}{8}$  inch opening thrown clear forward or back, and  $\frac{1}{4}$  inch opening hooked at 12 inches, both sides being the same. He claimed after running with steam that the valves were not square, or at least did not sound so. After squaring my way from dead center on wheels, and attempting to do it in his style by measuring on guides, the valves would show  $\frac{1}{4}$  inch of opening more on one side than the other. Who is right? A. You are.

(3) C. C. G. asks: Would a gun or other strong vessel, if filled completely with water and sealed up, and then subjected to intense cold, freeze and burst, or would the water remain liquid? A. Ordinarily, it would burst.

(4) W. J. M. asks: What is the effect of the gas of burning coal upon lime or mortar? A house was recently burnt under these circumstances: A light brick wood fire was kindled and afterwards every spark of fire was supposed to be extinguished. In an hour afterwards the house was discovered to be on fire in the upper part. One theory is that the coal gas had injured the mortar and rendered the chimney unsafe, and so the fire was communicated through the chimney thus rendered unsafe. A. If the mortar employed in the construction of the chimney were originally of good materials, it is not at all probable that it would have been injured by the constant contact with the products of combustion; the lime in the mortar, at the exposed surfaces, would under ordinary circumstances speedily be converted into carbonate, sulphide, hyposulphite, and finally entirely into sulphate of lime, which would resist further change. The real cause of the gradual disintegration and final destruction of chimneys is rather to be looked for in the constantly varying and unequal expansion and contraction of their constituent materials, caused by the heat of combustion in the furnaces and climatic changes, and aided by the occasional shocks, jars, and the almost constant vibration to which all such structures are subject.

(5) C. D. S. asks: Please give a rule for working out this problem: The chord of an arc is 120 feet, and the versed sine 1 foot; what is the radius? A. From the rule for finding the versed sine when the chord and radius are given, which is: Square half the chord and square the radius; deduct the square root of their difference from the radius, and the remainder will be the versed sine: it is easy to deduce that the radius is equal to  $(\text{versed sine})^2 + (\text{semichord})^2$

$2 \times \text{versed sine}.$   
(6) W. M. S. asks: How can I make a lead tree? A. Nearly fill a somewhat narrow-necked bottle with a saturated aqueous solution of acetate of lead, and suspend therein, just below the surface, a small bundle of zinc wires or strips, about two inches long; cork the bottle, and allow to stand undisturbed. The lead is precipitated by the zinc, which takes its place in the solution.

(7) E. A. T. asks: If the earth's axis were inclined 30°, what effect would it have upon the seasons? A. Their length would be the same; but in all places above 23° 5', the summer would be warmer and the winter colder.

(8) L. P. S. says: A magneto-electric machine is constructed on the principle of the Gramme machine, and used in a plating room. It seems to contradict a law which I supposed was unchangeable, namely, that, when the electric current was once established in a machine of this kind, it would continue to flow in the same direction so long as it revolved the same way, and the coils were undisturbed; but this does not appear to be always the case. The inducing magnets at one end of the revolving magnets became inert, probably from disconnection of the wire which supplied the exciting current. The wire, leading to the bath from this inert half of the machine, was changed to the corresponding electrode on the other section, which continued to give off a current. In this condition of things the plating went on very well, but with diminished power, for two or three hours; when, to the astonishment of the workmen, the current was found to be flowing in the wrong direction. The wires were then changed so as to bring the current right, and everything worked well for an hour or two, when it was traveling the wrong way again; and I find that other similar machines have behaved in the same manner under like conditions. I am at a loss to account for this singular action, and would like to have your opinion on the subject. A. The phenomenon described is common to most magneto-electric machines. It is caused by the extra current that is generated in the wires when the circuit is broken. One obvious remedy is never to open the circuit while the machine is running at full speed. There are others, but we think this will be found very satisfactory.

(9) P. J. H. asks: Can large telescopic lenses be made of the proper shaped glass cells filled with a liquid? A. No good lenses can be made this way on account of the flexure of the material.

(10) M. M.—The curious arrangement of the air bubbles you witnessed was probably caused by the ascending and descending currents of the warmer and cooler water in contact with the metallic sides of the vessel. The surface of the water in the center would thus be slightly higher than towards the sides of the cooler, and, owing to the capillary attraction at the points where the liquid was in contact with the metal, these would also be higher: anything, therefore, floating on the surface of the water would remain at an intermediate point. Cohesive attraction, we think, would explain the rest. We do not see anything in this explanatory of the nebular hypothesis you mention.

(11) D. F. asks: How can I restore the original color of small ornaments made of white holly and other light woods, that have grown yellow from age? A. Place them in a vessel over a quantity of chloride of lime (hypochlorite of lime) to which add a very small quantity of diluted sulphuric acid, and close the vessel tightly.

(12) R. B. C. says: A young friend has an aquarium. A silver fish which has been rusticated in it over a year has suddenly changed to a gold fish. Why is this? I should mention that the water, though changed often, is strongly impregnated with iron. A. We should feel better able to give an answer if we had seen the fish mentioned. It would probably be more nearly to the point to call the animal an "iron fish," in contradistinction to his more noble fellows, as the color is probably due, at least in part, to a slight incrustation of the scales with the yellowish-brown sesquioxide of iron.

(13) C. C. B. asks: Is there not an error in your statement that the Microscopical Society's screw has 55 threads per inch? A. Yes. It should have read 36.

(14) H. Mc. says: 1. Supposing that a wheel is 20 feet in diameter, with an axle of 8 inches, how much will a 10 lb. weight on the rim of the wheel raise on the axle? A. Between 300 and 400 lbs. 2. What amount of weight would be required on one side of the wheel to be equal to an eighty horse power engine? A. This question is too indefinite. A force of 1 lb., acting with sufficient velocity, would exert the same power as the engine.

(15) C. H. W. asks: Is the intensity of radiant heat in space or ether in inverse ratio of the square of the distance from the source of heat as it is in air? A. It is considered to be so.

(16) J. F. says: I am building a grist mill to use 48 cubic feet water per second. It is estimated 600 feet below the dam, and the water is to come in a pipe underground. What should be the size of a circular pipe to feed 48 cubic feet per second without losing more than 1 foot head? I find by using M. Prony's experiments, and also Messrs. Boulton and Watt's rules, that a pipe 4 feet diameter will feed that amount of water to a distance of 600 feet, with a frictional head of 10.4 inches? A. This seems to be right. Weisbach's formula, which is perhaps better authority, gives the friction head at about 9.5 inches; and as these are theoretical results, for clean and smooth pipes, it may be best to use a 48 inch pipe. 2. Would a flume near the mill be of any benefit? I think that a decked penstock in which the wheels are placed, giving the water plenty of access to them, is as good. The power of water is proportioned to the pressure; and a flume would not increase it at all, as the height of water in it would depend on the pressure only. Am I right? A. Yes.

(17) G. H. W. says: Please tell me of some mode of renovating and killing the smell on curled hair. A. Try fumigating in a large, tight box with the sulphurous acid gas evolved from a dish of burning sulphur.

(18) P. F. asks: With what velocity will water flow into the suction pipe of a pump which is 16 feet in perpendicular height, supposing that

the vacuum is perfect. Please give me a rule for ascertaining the velocity at any height. A. The velocity with which the water will flow is 8.02 times the square root of the effective head. In the case you have given, the total head is one atmosphere, equivalent to a column of water about 34 feet high. The lift is 16 feet, leaving 18 feet head, and from this must be subtracted the friction head, which depends upon the diameter of the pipe. Suppose the friction head to be 5 feet; this leaves 13 feet available head: whence the velocity will be about 29 feet per second.

(19) H. F. asks: How can I prevent broomcorn from breaking when worked up? A. Steep or boil the broomcorn in water, and then dry it.

(20) E. S. E. says: I am using a pump with connections made direct with the city water supply. I do not get a steady pressure, and find it impossible to use the exhaust steam, as the water sometimes rises, forcing the exhaust steam back and flowing into the cylinder of the engine, thereby endangering the cylinder head. What shall I do? A. Fit up a tank, which you can do very cheaply by using a hogshead, and draw your feed from that.

How can I test oils to find which is the best lubricant? A. The fact that one oil is heavier than another does not prove that it is better. You can best judge of the quality of different oils by using samples on the same bearing, and see how far a quantity of each, costing the same amount, will go.

(21) M. B. asks: Is there any internal application or other mode of preventing the very rapid destruction of pipes leading from stoves in which anthracite coal is burnt? In some cases the pipes do not last more than a winter. A. This is very probably due to the quantity of sulphides contained in the fuel. We do not know of any practical way of overcoming the difficulty except it be to use a better quality of coal, and pipes of the best Russian iron.

(22) G. S. P. says: A friend states that eggs cannot be hatched in an incubator with the heat coming from the bottom. I say they can. Which is right? A. The conditions are that the temperature should be uniform, not too great, or yet too low, and that the eggs should be turned occasionally. From whatever direction the source of heat, only provided that the above conditions are realized, we think the eggs may be successfully hatched.

(23) A. B. W. asks: What is the highest temperature that asbestos will resist without injury? A. Pure asbestos will resist the highest temperatures to which it may ordinarily be subjected; but at the temperature of the blast furnace or the oxyhydrogen jet, it fuses to an enamel-like glass.

(24) C. K. N. asks: 1. Is kerosene oil of the best grade, such as is used for illuminating purposes, likely to injure the leather or stitching of shoes when poured in to stop squeaking? A. No; but such treatment of shoes is not at all desirable. 2. What will prevent shoes from squeaking? A. Rasp, with a coarse rasp, the outsole and insole, and every other piece of leather that comes in contact in friction by the action of the foot. Then apply freely good wheat or rye paste. If this is well attended to from heel to toe, the boot or shoe will not squeak.

(25) C. asks: What is hyposulphate of soda, and has it any other name? A. You probably mean hyposulphite of soda; it is a salt formed by the combination of soda with hyposulphurous acid. We do not know that it has another name, except, perhaps, that of "hyppo," given to it by photographers, who use it largely as a developing bath.

(26) T. H. P. says: We have a stream of mine water throwing 70 gallons per minute, which we would like to bring down the side of the mountain in troughs, a distance of 850 feet, with a fall of 220 feet, to run an overshot water wheel, and pump up a stream of spring water throwing 10 gallons per minute, to a point 20 feet above the starting point of the mine water. Can it be done? If so, what should be the proportions for wheel, pump, stroke, diameter of bore, and size of gas pipe required? A. It is probable that you will have plenty of surplus power, under the conditions stated, so that you may use such apparatus as can most conveniently be applied.

(27) C. A. A. says: 1. I wish to make some billiard balls out of wood. What kind would be most suitable? A. Use rock maple or apple wood. 2. How can I stain and polish the same? A. Stain with extract of logwood, and polish with a little oil and shellac in alcohol.

(28) I. R. says: 1. I want to make a few electrotype plates, about 5 x 8 inches. What will be a cheap form of battery for the purpose, and how many cells are necessary? A. One or two cells of Daniell battery is sufficient. That known as the gravity form is easily arranged. It consists of a copper disk placed at the bottom of a jar and a zinc plate or casting supported from the top. Wires for connecting the battery in circuit lead from the two metals. The one soldered to the copper disk is insulated by a gutta percha covering on that portion which is within the jar. Fill the jar about  $\frac{2}{3}$  full with water in which a little sulphate of zinc has been dissolved. Then drop a few crystals of sulphate of copper on the bottom plate, taking care that none remains on the zinc, and the battery is ready for use. 2. How must the wax mold be connected with the wire? A. Push several small wires through the wax in different places, so that the ends just show the black lead over them. 3. Is there anything that can be substituted for plumbago to coat the mold with? A. Yes, but you will get good results with plumbago, if careful. 4. How thick ought the copper to be deposited, and how long will the process take? A. That is a question to be answered by individual taste.

Notes & Queries

It has been our custom for thirty years past to devote a considerable space to the answering of questions by correspondents; so useful have these labors proved that the SCIENTIFIC AMERICAN office has become the factotum, or headquarters to which everybody sends, who wants special information upon any particular subject. So large is the number of our correspondents, so wide the range of their inquiries, so desirous are we to meet their wants and supply correct information, that we are obliged to employ the constant assistance of a considerable staff of experienced writers, who have the requisite knowledge or access to the latest and best sources of information. For example, questions relating to steam engines, boilers, boats, locomotives, railways, etc., are considered and answered by a professional





Advertisements.

Inside Page, each insertion - - - 75 cents a line. Back Page, each insertion - - - \$1.00 a line.

Practical Draughtsman's Book of Industrial Design and Machinist's and Engineer's Drawing Companion;

HENRY CAREY BAIRD & CO. INDUSTRIAL PUBLISHERS AND BOOKSELLERS. 810 WALNUT STREET, Philadelphia.

WANTED—An intelligent mechanic to manage a large Steam Boiler Works, and control a large working force.

BUSINESS PROPERTY For Sale.

The Lansing Iron Works are now offered at private sale, consisting of a fine, convenient building, with sufficient land for the business, and closely adjacent to a railroad track.

H. B. BIGELOW & CO. New Haven, Conn.

THE Bigelow Engine, The Cheapest and Best Portable Engine offered to the Public. Price, 4 Horse Power.....\$300

SENT FREE 6000 NEW RECEIPTS. \$7 A DAY working at your homes. Address at once the BEVERLY CO., Chicago.

FOR SALE—In lots to suit, 2,000 worn out bright Gang Saws, at 4c. per lb.; 10,000 Files, suitable for re-cutting, at 6c. per lb.

STEEL NAME STAMPS, post paid, for 18c. per letter. STEEL STAMP WORKS, 213 Chapel St., New Haven, Ct.

THE HOADLEY PORTABLE STEAM ENGINE, WITH AUTOMATICAL CUT-OFF REGULATOR AND BALANCED VALVE.

HOW TO MAKE SPIRAL SPRINGS. By Joshua Rose. With three engravings of the tools, which are easily made, and complete practical directions for working, including Hardening and Tempering.

Y. A. FAY & CO. CINCINNATI, OHIO. WOOD WORKING MACHINERY. Woodworth Planers and Matchers, Daniels & Dimension Planers, Universal Wood Workers, Band & Circular

WANTED—One good 2d hand Power Shears; One Press, suitable for punching and shearing (½) five eighth bar Iron; also a Drop Hammer, 16 to 18 lbs. bet. grooves; one 25 h. p. Engine and Tubular Boiler.

\$200 a month. Outfit worth \$1 free to agents. EXCELSIOR M'FG CO., 151 Mich. Av., Chicago.

NORWICH University Scientific and Military School, Northfield, Vt. Address Prof. CHARLES DOLB.

Planing & Matching. Moulding, Re-sawing, and Tenoning Machines. Scroll Saws and General Woodworking Machinery.

AIR COMPRESSORS FOR ALL PURPOSES. A SPECIALTY OF HEAVY PRESSURES. THE NORWALK IRON WORKS CO., SOUTH NORWALK, CONN.

N. F. BURNHAM'S 1874 TURBINE Water Wheel Has DISPLACED hundreds of other Turbines, but HAS NEVER BEEN ITSELF DISPLACED.

MACHINERY OF EVERY DESCRIPTION, COLD ROLLED SHAFTING, HANGERS, PULLEYS, COUPLINGS, BELTING, TANTIE EMERY WHEELS AND GRINDERS, IN STOCK. GEORGE PLACE, 121 Chambers & 103 Reade Sts., New York City.

WE ENAMEL FINE JET BLACK every variety of turned wood work parts of machinery, castings, tin ware and other metal ware. ENAMELED JET GOODS, in wood or metal, made to order.

Wood-Working Machinery, Such as Woodworth Planing, Tongueing, and Grooving Machines, Daniel's Planers, Richardson's Patent Improved Tenon Machines, Mortising, Moulding, and Re-saw Machines, and Wood-Working Machinery generally.

MACHINERY OF IMPROVED STYLES FOR MAKING SHINGLES, HEADING, and STAVES; also GAUGE LATHES for TURNING HANDLES. Sole makers of Laps Pat. Shingle and Heading Sawing Machine. Address TRIVOR & CO., Lockport, N. Y.

TOY NOVELTIES Wanted—Will buy or manufacture on royalty. Address HAWES BROS., Toy Novelty Turning Mills, Monrocton, Bradford Co., Pa.

ROOTS' FORCE BLAST BLOWER. FIRST PREMIUM AWARDED AT PARIS & VIENNA. THOUSANDS IN USE BOTH IN THIS COUNTRY & EUROPE.

PROPOSALS FOR STOVES. WAR DEPARTMENT, QUARTERMASTER GENERAL'S OFFICE, WASHINGTON, D. C., August 28, 1876.

SEALED PROPOSALS will be received at this office until noon, October 3, 1876, for the early delivery to the Quartermaster's Department, at Philadelphia, Pa., or Jeffersonville, Ind., of two hundred Stoves, as follows:

20 Army Cast Iron Wood Heater, No. 1. 20 " " " " " 2. 20 " " " " " 3. 20 Army Wrought Iron Wood Heater, No. 4. 20 Army Cast Iron Coal Heater, No. 6. 20 Army Parlor Coal Heaters. 20 Army Cooking Ranges, No. 1.

WANTED—To Let on Royalty, a patented 2 horse Corn Planter. A. C. B., Box 525, Charleston, Ill.

DAYTON CAM PUMP, Designed especially for Boiler Feeding. Are Pumping water at 268° F. No Dead Centers. The Steam Valve is a plain Slide Valve, identical to the slide valve of a Steam Engine, but derives its motion from a cam.

ENGINE LATHES, PLANERS, DRILLS, &c. Send for Catalogue. DAVID W. POND, Successor to LUCIUS W. POND, Worcester, Mass.

BLOSSOM ROCK, HARBOR OF SAN FRANCISCO. Full Account of its Removal, Method and Cost. By Col. R. S. Williamson. With 25 illustrations, diagrams, &c. Presenting valuable information for engineers. Price 10 cents. Contained in SCIENTIFIC AMERICAN SUPPLEMENT, No. 24. To be had at this Office and at all News Dealers.

LADIES can make \$5 a day, in their own city or town. Address ELLIS M'FG CO., Waltham, Ms.

WHIPPLE'S Patent Door Knob. Awarded a Bronze Medal at the American Institute Fair for 1874. The Judges say: "We consider this method of fastening DOOR KNOBS a great improvement over anything yet invented for the purpose, as it obviates the use of side screws and washers, and can be regulated to suit any thickness of Door." Send for Circular.

THE TRADE ENGINE. Noiseless in operation—Perfect in workmanship—all light parts of Cast Steel. Every Engine Indicated, and valve corrected to give the highest attainable results.

WATER SUPPLY FOR TOWNS AND VILLAGES. By Clarence DeLafield, C. E. A concise and valuable Report, showing the Costing Merits of the Various Systems—Discussion of the Holly System, its Merits and Defects—The Reservoir System, with Pumps, Cost, and Advantages—Results Obtained and Economy of Use of Various Systems in Different Towns, with Names and Duty Realized, Facts and Figures to enable Town Committees to judge for themselves as to the system best suited for their wants—The Best Sources of Water Supply—Water-Bearing Rocks—Artesian Wells, their feasibility, excellence, and cost of boring—Importance of Pure Water—How Surface Water is Rendered Impure—Cost of Water Pipes, from 2 to 12 inches diameter, for Towns, including laying, all labor, materials, gates, joints, etc.—Estimates of Income and Water Rates for Supply of 1,000 Buildings. Price 10 cents. Contained in SCIENTIFIC AMERICAN SUPPLEMENT, No. 27. To be had at this Office and at all News Dealers.

D. LANGELL'S ASTHMA & CATARRH REMEDY. Having struggled twenty years between life and death with ASTHMA, I experimented by compounding roots and herbs and inhaling the medicine, and fortunately discovered a cure for ASTHMA and CATARRH.

SPARE THE CROTON & SAVE THE COST. Driven or Tube Wells furnished to large consumers of Croton and Ridgewood Water. WM. D. ANDREWS & BRO., 414 Water St., N. Y., who control the patent for Green's American Driven Well.

GEO. W. READ & CO., STEAM BAND SAW AND VENEER CUTTING MILL, 186 to 200 LEWIS ST., foot 5th and 6th Sts., E. R., N. Y. Always on hand, FULL STOCK of SEASONED Hard-Wood Lumber AND CHOICE FIGURED VENEERS.

Water Wheels. More than four times as many of Jas. Leffel's improved Double Turbine Water Wheels in operation than any other kind.

\$100. REWARD. \$100. THIS MOUSTACHE produced on a smooth face by the use of DYKES' BEARD ELIXIR without injury, or will forfeit \$100. Price by mail in sealed package 25 cents, for three 50 cents. A. L. SMITH & CO., Ag'ts, Palatine, Ill.

EAGLE FOOT LATHES, With Scroll and Circular Saw Attachments, Slide Rest, Tools, &c.; also Small Engine Lathes, Metal Hand Planers, &c. Neatest designs, superior finish. Low Prices. Our new Catalogue describes these and every tool necessary for the Amateur or Artizan. Send for it.

VINEGAR. HOW MADE IN CIDER, Wine or Sorghum, without using drugs. Name paper, and address F. I. SAGE, Springfield, Mass.

PATENT COLD ROLLED SHAFTING. The fact that this shafting has 75 per cent greater strength, a finer finish, and is truer to gage, than any other in use, renders it undoubtedly the most economical.

STONE and Ore Breaker. Crushes all hard and Brittle Substances to any required size. Also, any kind of Stone for Roads and for Concrete, &c. Address BLAKE CRUSHER CO., New Haven, Conn.

REVERSIBLE HOISTING ENGINE FOR ALL PURPOSES. Cheap, simple, durable, and effective.

WANTED Men to travel and sell goods to dealers. No peddling. \$80 a month, hotel and traveling expenses paid. Monitor Manufacturing Co., Cincinnati, Ohio.

J.M. CARPENTER MANUFACTURER OF FIRST CLASS TAPS AND DIES, Pawtucket, R. I.

OTIS' SAFETY HOISTING Machinery. OTIS, BROS. & CO. No. 348 BROADWAY NEW YORK. ENGINES AND BOILERS.

ENGINEER'S SITUATION WANTED.— A Lieutenant Colonel of Engineers of the French Polytechnic School, late Chief Engineer of a State and a Railroad Company, desires an engineer's position in the United States or to go abroad.

The Toll-Gate! Prize Picture sent free! An ingenious gem! 50 objects to find! Address, with stamp, E. C. ABBEY, Buffalo, N. Y.

A NEW DEPARTURE. Selling in every city and town in the U. S. AND CANADA. Introducing our Old and Staple MANUFACTURES. \$25 PER MONTH, Hotel and Traveling Expenses paid.

STEAM ENGINES FOR SALE. I offer the following very superior Todd & Rafferty Engines for sale at greatly reduced prices: One 18x36, one 14x18 (sawmill), one 12x14, one 11x24, one 10x24, one 9x20, one 7x16, one 5x10 on legs, one 8x12, portable one 8x16, double hoisting; all first class and entirely new.

IRON BRIDGE BUILDING—A complete description, with dimensions, working drawings, and perspectives of Girard Avenue Bridge, Philadelphia, Pa. With foundations of piers. Ten copies of report, 50 cents. Contained in Nos. 1, 2, and 4 of SCIENTIFIC AMERICAN SUPPLEMENT, 10 cents per copy. To be had at this office, and of all news agents.

JOYFUL News for Boys and Girls!! Young and Old!!! A NEW INVENTION just patented for them! Cut Sawing, Scroll Sawing, Turning, Boring, Drilling, Grinding, Polishing, All on one Cabinet Lathe, on Wheels. Price from \$5 to \$80. For Pamphlet, address EPHRAIM BROWN, Lowell, Mass.

PATENT SCROLL SAWS. Our specialty is Scroll and Band Saws. Over 300 Machines in use. SUPERIOR TO ALL AND LESS PRICE. GOLDSMAN, EGAN & CO., Cor. 2nd & Central Ave., Cincinnati, O.

BEAN'S FRICTION CLUTCH, The Best on the Globe. Universally adopted by ROLLING MILLS. No breakage of Gear or Machinery. None other can weigh the POWER. SAFETY ELEVATORS. D. FRISBIE & CO., New Haven, Conn.

FOR ALL KINDS OF MACHINERY—Apply to S. C. HILLS, 51 Cortlandt St., New York.

Steel Castings, From ½ to 10,000 lbs. weight. An invaluable substitute for expensive forgings, or for malleable iron castings requiring great strength. Send for circular and price list to CHESTER STEEL CASTING COMPANY, EVELINA STREET, PHILADELPHIA, PA.

THE CENTENNIAL INTERNATIONAL EXHIBITION OF 1876.—The full History and Progress of the Exhibition, maps of the grounds, engravings of the buildings, news and accounts of all the most notable objects, are given weekly in the SCIENTIFIC AMERICAN SUPPLEMENT. Terms, \$5 for the year; single copies 10 cts. To be had at this office, and of all news agents. All the back numbers, from the commencement on January 1, 1876, can be had. Those who desire to possess a complete and splendid illustrated Record of the Centennial Exposition, should have the SCIENTIFIC AMERICAN SUPPLEMENT.

HARVARD UNIVERSITY DENTAL SCHOOL. The next year of this school begins under the new plan, Sept. 28, 1876, and ends June 27, 1877, with a recess of one week at Christmas and another in February. The teaching is consecutive through a course of two years, the instruction of one year not being repeated in the next; that of the first year being identical with that of the Harvard Medical School and by the same Professors. By this plan, the amount of instruction given is double that of any other strictly dental school, and at slightly increased cost. For information, address THOMAS H. CHANDLER, Dean, 22 Tremont Street, Boston, Mass.

Stubs' Files, Tools & Steel. Machinists' Fine Tools, Jewelers' and Engravers' Supplies, Lathes, Chucks, Vises, Taps and Dies, Reamers, Morse Drills, Files, and small Tools of all kinds for amateurs or practical workmen. Hubert's French Emery Paper, Grobet's Swiss Files, Bracket Saws, etc. Agent for the Almond Drill Chuck. Best and cheapest in the market. Price \$5.00. J. M. MONTGOMERY, 105 Fulton St., New York.

SHAFTS, PULLEYS, HANGERS, COUPLINGS ETC. In Stock, and for Sale by WILLIAM SELLERS & CO., Philadelphia, and 79 Liberty St., New York. Price lists and pamphlets on application.

BLAKE'S PATENT Stone and Ore Breaker. Crushes all hard and Brittle Substances to any required size. Also, any kind of Stone for Roads and for Concrete, &c. Address BLAKE CRUSHER CO., New Haven, Conn. \$250 A MONTH—Agents wanted everywhere. Business honorable and first class. The list sent free. Address J. WORTH & CO., St. Louis, Mo.

Advertisements.

Back Page . . . . . \$1.00 a line. Inside Page . . . . . 75 cents a line. Engravings may head advertisements at the same rate per line, by measurement, as the letter press. Advertisements must be received at publication office as early as Friday morning to appear in next issue.

CELEBRATED FOOT LATHES



Foot Power, Back-gear'd Screw Lathes, Small Hand and Power Planers for Metal, Small Gear Cutters, Slide-rests, Ball Machine for Lathes, Foot Scroll Saws, light and heavy, Foot Circular Saws. Send for Illustrated Catalogues. N. H. BALDWIN Laconia, N. H.

Common-Sense Rockers and Chairs.

No Office, Library, Public or Private, Sitting-Room or Piazza, should be without some of my ROCKING CHAIRS. So Roomy, so Easy and so Cool, these sultry days. Try my Puritan Rocker or Old Point Comfort, and you will find Rest.



Old Point Comfort.

Send stamp for Illustrated Price List to F. A. SINCLAIR, Mottville, N. Y.

WIRE ROPE

Address JOHN A. ROEBLING'S SONS, Manufacturers, Trenton, N. J., or 117 Liberty St., New York. Wheels and Rope for conveying power long distances. Send for Circular.

COMPRESSED AIR MOTIVE POWER.—For particulars of the most recent practice, send 20 cents for SCIENTIFIC AMERICAN SUPPLEMENT, Nos. 1 and 2, containing 5 engravings of the "Compressed Air" Locomotives now in use in St. Gothard Tunnel Works, with dimensions, etc.



[ESTABLISHED 1846.]

Munn & Co.'s Patent Offices.

The Oldest Agency for Soliciting Patents in the United States.

THIRTY YEARS' EXPERIENCE.

MORE PATENTS have been secured through this agency, at home and abroad, than through any other in the world.

They employ as their assistants a corps of the most experienced men as examiners, specification writers, and draftsmen that can be found, many of whom have been selected from the ranks of the Patent Office.

SIXTY THOUSAND inventors have availed themselves of Munn & Co.'s services in examining their inventions and procuring their patents.

MUNN & CO., in connection with the publication of the SCIENTIFIC AMERICAN, continue to examine inventions, confer with inventors, prepare drawings, specifications, and assignments, attend to filing applications in the Patent Office, paying the government fees, and watch each case step by step while pending before the examiner. This is done through their branch office, corner F and 7th streets, Washington. They also prepare and file caveats, procure design patents, trademarks, and reissues, attend to rejected cases (prepared by the inventor or other attorneys), procure copyrights, attend to interferences, give written opinions on matters of infringement, furnish copies of patents, and, in fact, attend to every branch of patent business both in this and in foreign countries.

A special notice is made in the SCIENTIFIC AMERICAN of all inventions patented through this agency, with the name and residence of the patentee. Patents are often sold, in part or whole, to persons attracted to the invention by such notice.

Patents obtained in Canada, England, France, Belgium, Germany, Russia, Prussia, Spain, Portugal, the British Colonies, and all other countries where patents are wanted, at prices greatly reduced from former rates. Send for pamphlet pertaining specially to foreign patents, which states the cost, time granted, and the requirements on each country.

Copies of Patents.

Persons desiring any patent issued from 1836 to November 26, 1867, can be supplied with official copies at reasonable cost, the price depending upon the extent of drawings and length of specifications.

Any patent issued since November 27, 1867, at which time the Patent Office commenced printing the drawings and specifications, may be had by remitting to this office \$1.

A copy of the claims of any patent issued since 1836 will be furnished for \$1.

When ordering copies, please to remit for the same as above, and state name of patentee, title of invention, and date of patent.

A pamphlet containing full directions for obtaining United States patents sent free. A handsomely bound Reference Book, gilt edges, contains 140 pages and many engravings and tables important to every patentee and mechanic, and is a useful handbook of reference for everybody. Price 25 cents, mailed free.

Address MUNN & CO., Publishers SCIENTIFIC AMERICAN,

37 Park Row, N. Y.

BRANCH OFFICE—Corner F and 7th Streets, Washington, D. C.

ROCK-DRILLING MACHINES

AND AIR COMPRESSORS, Manufactured by BURLEIGH ROCK DRILL CO., Fitchburg, Mass. Send for Pamphlet.



REYNOLDS & CO., 145 EAST ST., NEW HAVEN, CT., MANUFACTURE

Iron and Steel Set Screws, Round, Square, and Hexagon Head; Machine and Cap Screws; Piano, Knob, and Lock Screws; Machine, Bridge, and Roof Bolts, Bolt Ends, Blanks, Nuts, Washers, etc., of every description. Send for Price List.

MILL STONE DIAMOND DRESSING MACHINES. Simple, effective, and durable. Also diamond-point tools for turning Emery Wheels, Grinding stones, Chilled Iron, and Paper Calendar Rolls, and other mechanical purposes. Also, Diamond Tools, Saws, and Drills made to order. J. DICKINSON, 64 Nassau St., N. Y.

THE NEW FIFTY DOLLAR BACK GEAR, SCREW-CUTTING FOOT LATHES. Send for Circular to POST & CO., Cincinnati, Ohio.

Lawrence Scientific School, HARVARD UNIVERSITY.

THIS School provides a four years' course in Engineering, leading to the degree of Civil Engineer, or Mining Engineer; and four years' courses in Chemistry, in Natural History, and in Mathematics, Physics, and Astronomy, each of which leads to the degree of S. B. A large portion of the instruction is the same as that given to undergraduates in the College. The University is amply provided with laboratories, apparatus and collections. Students of the Scientific School can occupy rooms in College Buildings and board at Memorial Hall. Examinations for admission will be held September 28 and 29, beginning at 8 A. M. For information, address JAMES W. HARRIS, Secretary.

GENUINE CONCORD AXLES

The Standard—Best Stock—Finest Finish—MANUFACTURED ONLY BY D. ARTHUR BROWN & CO. Fisherville, N. H.

W. W. JOHNS' PATENT ASBESTOS MATERIALS.

Asbestos Roofing, with the improved White Asbestos Fire Proof Coating, for steep or flat Roofs in all climates. Asbestos Roof Coating, for old Leaky Roofs. Asbestos Cement, for repairing Leaks on Roofs. Asbestos Roof Paint, for Tin Roofs, Ironwork, &c. Asbestos Paints—all colors—for structural purposes. Asbestos Fire Proof Coating, for wood work, &c. Asbestos Steam Pipe and Boiler Coverings. Asbestos Steam Packing, flat and round, all sizes. Sheathing Felts, Vermin-Proof Lining, &c. These articles are ready for use, and can be easily applied by any one. Send for Pamphlets, Price Lists, &c. H. W. JOHNS 87 Maiden Lane, N. Y., Patentee and Manufacturer. Established 1858.

SNYDER'S LITTLE GIANT STEAM ENGINE. The Best in the Country. One-Horse Power, with tubular boiler complete, only \$150. Two-Horse Power, only \$200. Three-Horse Power, only \$250. Call and Examine or send for illustrated catalogue. WARD B. SNYDER, 84 Fulton St., New York.

NON-COMBUSTIBLE STEAM BOILER & PIPE COVERING WITH "AIR SPACE" IMPROVEMENT.

Saves 10 to 20 per cent. CHALMERS SPENCE CO., Foot E. 9th St., N. Y.; 1302 N. 2nd St., St. Louis, Mo. THREE THINGS IN ONE.—VENTILATION of a Fire Place; RADIATION of a Stove; CIRCULATION of a Furnace. Pure Air and an Even Temperature throughout a Room. "THE CENTENNIAL," Annex Main Building. THE OPEN STOVE VENTILATING COMPANY, 107 Fulton St., New York.

WROUGHT IRON BEAMS & GIRDERS

THE UNION IRON MILLS, Pittsburgh, Pa.—The attention of Engineers and Architects is called to our improved Wrought-Iron Beams and Girders (patented), in which the compound welds between the stem and flanges, which have proved so objectionable in the old mode of manufacturing, are entirely avoided. We are prepared to furnish all sizes at terms as favorable as can be obtained elsewhere. For descriptive lithograph, address Carnegie Brothers & Co., Union Iron Mills, Pittsburgh, Pa.

Todd & Rafferty Machine Co.

MANUFACTURERS OF The celebrated Greene Variable Cut-Off Engine, Lowe's Patent Tubular and Flue Boilers, Plain Slide Valve Stationary, Hoisting, and Portable Engines. Boilers of all kinds. Steam Pumps, Mill Gearing, Shafting, &c. Silk, Tow Ovens, Bagging, Rope, Flax, and Hemp Machinery. Agents for the New Haven Manufacturing Co.'s Machinist's Tools, for Judson's Governors and Stop Valves, Sturtevant Blowers, and Differential Pulley-Blocks. WAREHOUSES, 88 LIBERTY STREET, NEW YORK. WORKS, PATERSON, NEW JERSEY.

PERFECT NEWSPAPER FILE.

The Koch Patent File, for preserving newspapers, magazines, and pamphlets, has been recently improved and price reduced. Subscribers to the SCIENTIFIC AMERICAN and SCIENTIFIC AMERICAN SUPPLEMENT can be supplied for the low price of \$1.50 by mail, or \$1.25 at the office of this paper. Heavy board sides; inscription "SCIENTIFIC AMERICAN," in gilt. Necessary for every one who wishes to preserve the paper. Address MUNN & CO., Publishers SCIENTIFIC AMERICAN.

WHOM IT PAYS!

As a rule, it pays best to advertise what one has to sell or wishes to purchase, in papers having the largest circulation among the class of persons likely to be interested in the article. Parties having Manufacturing Establishments to sell or lease, or who wish Estimates made for Constructing Bridges, Dams, Iron Buildings, Furnaces, Heating Apparatus, Steam Engines, Boilers, Wood and Iron Working Machinery, Agricultural Implements, or Contracts for Engineering Works of all kinds, will find that it pays to advertise in the SCIENTIFIC AMERICAN.

The value of the SCIENTIFIC AMERICAN as an advertising medium cannot be over-estimated. It goes into all the machine and workshops in the country, and is taken at the principal libraries and reading rooms in the United States and Europe.

The SCIENTIFIC AMERICAN and SCIENTIFIC AMERICAN SUPPLEMENT have a larger circulation than all other papers of their kind in the world combined; and at no period since the commencement of the publication of these papers has the weekly circulation been as large as at the present time.

The actual issue of the SCIENTIFIC AMERICAN is 47,500 per week, and of the SCIENTIFIC AMERICAN SUPPLEMENT, 15,000, making the combined circulation, 62,500 every week.

If anything is wanted in the mechanical line, advertise for it in the SCIENTIFIC AMERICAN.

If one has a patent or machinery to sell, advertise in the SCIENTIFIC AMERICAN.

If any one is exhibiting at the Centennial, it will pay them to advertise where they may be found.

For rates, see the first column of the last page of this paper.

The Supplement.

Next to the SCIENTIFIC AMERICAN, the SCIENTIFIC AMERICAN SUPPLEMENT has the largest circulation of any paper of its class published. The SUPPLEMENT is a distinct publication from the SCIENTIFIC AMERICAN, and has a large circulation other than among the subscribers of the regular edition. Terms for advertising are very low, as follows:

Back Page, tinted cover . . . . . 35c. a line } EACH INSERTION. Inside page . . . . . 25c. a line }

Discount for large space, and to quarterly advertisers. Address the publishers.

Munn & Co.,

37 Park Row, New York.

Brayton Ready Motor.

It has no boiler, is safe, economical, started by any one in one minute, occupies small space, and gives an unsurpassed steady, reliable power. Address

Penna. Ready Motor Co., 132 N. 3d St., Philadelphia, Pa.

Working Models

And Experimental Machinery, Metal or Wood, made to order by J. F. WERNER, 62 Center St., N. Y.

Lathes, Planers, Shapers, Drills, Gear & Bolt Cutters, &c. E. GOULD, Newark, N. J.

HANDASYDE'S COMPOSITION For the Removal and Prevention of Incrustation in Steam Boilers.

Used by the principal Railroads, Coal Mines, and General Manufacturers in Great Britain and Ireland. Satisfaction guaranteed. The best and cheapest in the market. Send for circulars and testimonials. G. C. CAMPBELL, AGENT, 24 Broadway, New York.

Stone Channeling or Quarrying Machine,

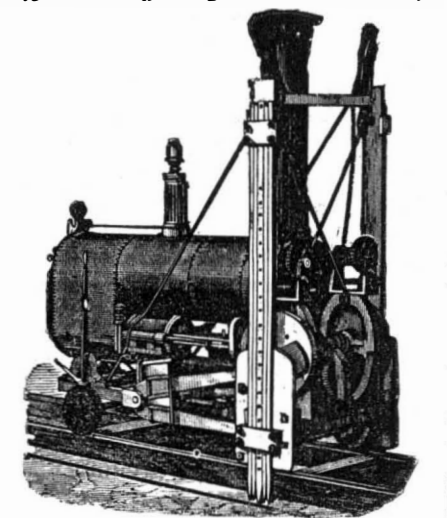

WARDWELL PATENT, FOR CUTTING STONE INTO VARIOUS SIZES AND DIMENSIONS IN ALL KINDS OF QUARRIES. STEAM STONE CUTTER CO., RUTLAND, VT. SOLE PROPRIETORS AND MANUFACTURERS.

Three Machines at Philadelphia Exhibition, Annex No. 2, Machinery Hall.

ROGERS' TANNATE OF SODA BOILER SCALE PREVENTIVE. JOS. G. ROGERS & CO., Madison, Ind. Send for book on Boiler Incrustation.

Portland and Keene's Cement.

From the best London Manufacturers. For sale by JAMES BRAND, 85 Beekman St., New York. A Practical Treatise on Cement furnished for 25 cents.

Niagara Steam Pump Works

ESTABLISHED 1826. CHARLES B. HARDICK, No. 23 Adams Street, BROOKLYN, N. Y.

The Tanite Co., STROUDSBURG, PA.

EMERY WHEELS & GRINDERS GEO. PLACE, Gen'l. Agent for N. Y. city and State.

Machinists' Tools.

New and Improved PATTERNS. Send for new illustrated catalogue. Lathes, Planers, Drills, &c. NEW HAVEN MANUFACTURING CO. New Haven, Conn.

M. SELIG JUNIOR, & CO., Importers of American Machinery, Tools, Agriculture, Implements, Wholesale and Export Hardware and Machinery Merchants. Est'd 1866. LONDON, ENGLAND, and BERLIN, GERMANY.

PORTLAND CEMENT

ROMAN & KEENE'S. For Walks, Cisterns, Foundations, Stables, Cellars, Bridges, Reservoirs, Breweries, etc. Remit 10 cents for Practical Treatise on Cements. S. L. MERCHANT & Co., 76 South St. New York.

PUNCHING AND DROP PRESSES. MIDDLETOWN, CONN. For the Best and Cheapest, address THE STYLES & PARKER PRESS CO., MIDDLETOWN, CONN.

BOGARDUS' PATENT UNIVERSAL ECCENTRIC MILLS—For grinding Bones, Ores, Sand, Old Crucibles, Fire Clay, Guanos, Oil Cake, Feed, Corn, Corn and Cob, Tobacco, Smut, Sugar, Salts, Roots, Spices, Coffee, Coconut, Flaxseed, Asbestos, Mica, etc., and whatever cannot be ground by other mills. Also for Paints, Printers' Inks, Paste Blacking, etc. JOHN W. THOMSON, successor to JAMES BOGARDUS corner of White and Elm Sts., New York

DAMPER REGULATORS BEST AND LEVERS. GAGE COCKS. MURRILL & KEIZER, 44 Holliday St., Balt.

HARTFORD STEAM BOILER Inspection & Insurance COMPANY.

W. B. FRANKLIN, V. Pres't. J. M. ALLEN, Pres't. J. B. PIERCE, Sec'y.

NOYE'S Mill Furnishing Works

are the largest in the United States. They make Burr Millstones, Portable Mills, Smut Machines, Packers, Mill Picks, Water Wheels, Pulleys and Gearing, specially adapted to flour mills. Send for Catalogue. J. T. NOYE & SON, Buffalo, N. Y.



SCIENTIFIC AMERICAN, FOR 1876.

THE MOST POPULAR SCIENTIFIC PAPER IN THE WORLD.

THIRTY-FIRST YEAR.

VOLUME XXXV.—NEW SERIES.

The publishers of the SCIENTIFIC AMERICAN beg to announce that on the first day of July, 1876, a new volume commenced. It will continue to be the aim of the publishers to render the contents of the new volume more attractive and useful than any of its predecessors.

To the Mechanic and Manufacturer.

No person engaged in any of the mechanical pursuits should think of doing without the SCIENTIFIC AMERICAN. Every number contains from six to ten engravings of new machines and inventions which cannot be found in any other publication.

The SCIENTIFIC AMERICAN is devoted to the interests of Popular Science, the Mechanic Arts, Manufactures, Inventions, Agriculture, Commerce and the industrial pursuits generally; and it is valuable and instructive not only in the Workshop and Manufactory, but also in the Household, the Library, and the Reading Room. Each volume contains hundreds of Notes, Receipts, and Suggestions and Advice, by Practical Writers, for Working Men and Employers, in all the various arts.

TERMS OF SUBSCRIPTION—POSTAGE PAID BY US.

One copy Scientific American, one year . . \$3 20 One copy Scientific American, six months. 1.60 One copy Scientific American, three months 1.00 One copy Scientific American and one copy Scientific American Supplement, both for one year, post-paid . . . . . 7.00

The Scientific American Supplement.

A weekly paper, uniform in size with the SCIENTIFIC AMERICAN, but a distinct publication. It contains working drawings of engineering works, and elaborate treatises on every branch of Science and Mechanics, by eminent writers, at home and abroad. An illustrated cover protects the handsomely printed sheets. Price, \$5.00 per annum Single copies 10 cents.

Remit by postal order, draft, or express. Address all letters and make all Post Office orders and drafts payable to

MUNN & CO., 37 PARK ROW, NEW YORK.

THE "Scientific American" is printed with CHAS. ENU JOHNSON & CO'S INK. Tenth and Lombard Sts., Philadelphia, and 59 Gold St., New York