

SCIENTIFIC AMERICAN

A WEEKLY JOURNAL OF PRACTICAL INFORMATION, ART, SCIENCE, MECHANICS, CHEMISTRY, AND MANUFACTURES.

Vol. XXVII.—No. 11.
NEW SERIES.]

NEW YORK, SEPTEMBER 14, 1872.

[\$3 per Annum.
[IN ADVANCE.]

IMPROVED STEAM TRAP.

In the many processes of manufactures, etc., where steam is employed as a heating agent, the removal of the water of condensation from the pipes of the heating apparatus as fast as it accumulates, without, at the same time, wasting steam, is an object of the most desirable character. Devices of various forms have been designed for its accomplishment, among which brass expansion tubes and copper floats have occupied a prominent position. The former, however, are rendered inoperative upon becoming slightly coated with deposit, and allow the steam to pass off with the water; while the float, which is likely to become filled with water, has proved unreliable in giving sufficient power to work the necessary mechanism. The steam trap now illustrated was designed to obviate the many difficulties experienced in using the ordinary traps, by providing a machine of simple construction, possessing the positive power adequate to its efficient operation. It is the invention of Mr. R. Berryman, of Hartford, Conn., whose feed water heater was lately illustrated in these columns. It is shown in perspective in Fig. 1, and in section in Fig. 2 of our engravings.

The supply pipe, A, conveys to the trap the condensed water from whatever steam apparatus it may thereby be connected with. B is a bucket which is suspended from one end of the lever shown. This lever is fastened to a rock shaft or spindle, one end of which extends through the stuffing box shown more particularly in Fig. 1. To the outer end of the rock shaft is attached the lever, C, which controls, by the connecting mechanism represented, the valve in the discharge pipe, D, through which the condensed water is conveyed to any desired place. The bucket, B, is partially counterbalanced by the weight seen on the lever, C, so that, when the trap fills with water and the bucket loses weight by being submerged therein, the weight on the lever, C, falls, depresses the lever, opens thereby the valve in the pipe, D, and allows the contained water to be discharged. These conditions are represented in Fig. 1.

When the condensed water falls to about half the height of the trap casing, the bucket regains sufficient weight to raise the weighted lever, and thereby close the valve. When the valve is closed, at least six inches of water still covers the mouth of the discharge pipe, so that loss of steam is entirely prevented. The operation, as described, is repeated whenever the drip raises the water in the trap to the required height.

The power exerted by the ordinary float is equal to the weight of water it displaces, or, in other words, to the weight of the material composing it. This cannot, of course, be great, as otherwise the float would either sink or have to be made of inconveniently large dimensions. The power derived from the bucket used, as described in this trap, is equal to the solid contents of the bucket in weight of water; that is to say, if the submerged bucket measures one cubic foot, the pull exerted by it, on withdrawal of the water, would equal 62½ pounds. The inventor claims that this construction renders the trap as sensitive in its action as a pair of scales. It adapts itself to all conditions, either discharging a very small volume or throwing a solid pipe full as occasion requires; when sufficient water is supplied by condensation, it stands on a balance and discharges a constant stream. It is further claimed that the facilities for repair are unsurpassed on account of the easy access to the valve. The cock seen at the top of the trap is to permit the expulsion of air.

Fig. 3 represents a modification of the apparatus, in which it is used to feed the condensed water back to the boiler without the intervention of pumps. E is a cylinder which is connected with the water space of the boiler by a pipe from its bottom, which pipe has the check valve shown opening outwardly from the cylinder. The inlet or drip pipe from the steam coils is connected, by the branch pipes at F, with the trap and with the cylinder, E, as shown. Each of these branch pipes is provided with the check valve represented, opening inwards. The pipe, G, connects the steam space of the boiler with the cylinder, and a valve in G is opened or closed by the trap lever, as indicated. The trap is connected by two pipes, one from its top and one from its bottom, with

the cylinder and its pipe in the manner delineated. The operation is as follows: As the water flows in from the coils, the check valves at F open and allow it to fill both the cylinders and the trap to equal heights until the bucket in the trap is sufficiently submerged to allow its weighted lever to fall and open the valve in the pipe, G. The check valves at F then close, and the water in the trap is held there until the water in the cylinder, E, has been discharged into the boiler and has fallen to the lower mouth of the upper pipe leading from the trap to the cylinder. The steam then ascends this pipe, and the water in the trap flows out through the lower one until the bucket falls and shuts off steam.

The water of condensation then again flows through the

are the manufacturers, and further information may be obtained of J. B. Davis & Co., of the same city.

Prehistoric Museum.

The interesting collection of ethnology and prehistoric remains, bequeathed by the late Mr. Henry Christie, is now arranged in the museum, 103 Victoria street, Westminster, London, admission to which is by ticket, available only on Fridays, from ten to four. The tickets are obtained at the British Museum itself on any of the open days, on application. The collection (in four rooms) contains prehistoric remains of Europe, Asia, and Africa. The flint implements from the drift are here most

beautifully and symmetrically arranged, and you can observe, even from that period, the advance from the rudely chipped celt to its more polished successor. Daggers, spear heads, saws, arrow heads, beside celts, chisels, and gouges, are here all represented. Some from Santon Downham, Norfolk, from Hoxne, Suffolk, the Yorkshire wolds, the Irish celt, axe, and hammer heads, etc., of their own peculiar type. Most interesting, too, are the remains from the caves of Dordogne, France, consisting chiefly of the animal remains of the mammoth, hyena, reindeer, and horse, some of the bones of the former having the figure of the animal itself engraved on them; of flint and worked bone implements, arrow heads and scrapers, barbed spear heads for fishing, and ornaments of fossil shells, with needles from the shank bones of the horse. These form the most valuable part of the collection. In contrast with them is the ethnographical collection

(modern races), and notably in this are the Esquimaux, exhibiting, in the chipped arrow heads and scrapers of siliceous materials, harpoon heads, and bone needles, their identity with their prehistoric prototypes. Of special interest are the objects from ancient Mexico—sculpture, pottery of different kinds, arrow heads, etc., the most remarkable among which being a mask formed out of a human skull, coated entirely with a mosaic work of turquoise and obsidian. The eyes are made of iron pyrites, very highly polished, so as to resemble small convex mirrors; the teeth of a white stone, the mouth being made to open; the mask is furnished with straps, so as to be worn. Here are, also, ancient earthen pipes in the form of animals, from the mounds of Ohio, North America, which bring to mind the buried cities of the northern continent, a subject long the wonder of the historic student. In these divisions the ethnologist may study the manners, customs, and dress of the different races of man, shown in their war implements, articles of dress and domestic use, their musical instruments, etc., through tribes from the northwest coast of America, the Asiatic Islands, China, Japan, North and Central Africa, the Polynesian group, all exhibiting the characteristics of the various races. To be brought face to face with the remnants of a vast antiquity excites in the mind of the spectator a deep and thrilling interest, as he sees in these rude emergencies of almost primitive man the gradual development into higher and still higher types of civilization. —*Science Gossip.*

Sand Paper.

THE *American Builder* gives the following method of making sand paper of superior quality, at almost a nominal cost. The device for making sand paper is simple, and at hand to any one who has occasion to use the paper. A quantity of ordinary window glass is taken—that having a green color is said to be best—and pounded fine, after which it is poured through one or more sieves of different degrees of fineness to secure the glass for coarse or fine paper. Then any tough paper is covered evenly with glue, having about one third more water than is generally employed for wood work. The glass is sifted upon the paper, allowed a day or two in which to become fixed in the glue, when the refuse glass is shaken off, and the paper is fit for use. This sand paper costs little, and is better than that ordinarily bought, in which sand is frequently mingled with the glass.

In California they make "metallic tubular wheelbarrows," which are entirely of iron, stronger and lighter than the wooden ones, and much more durable withal.

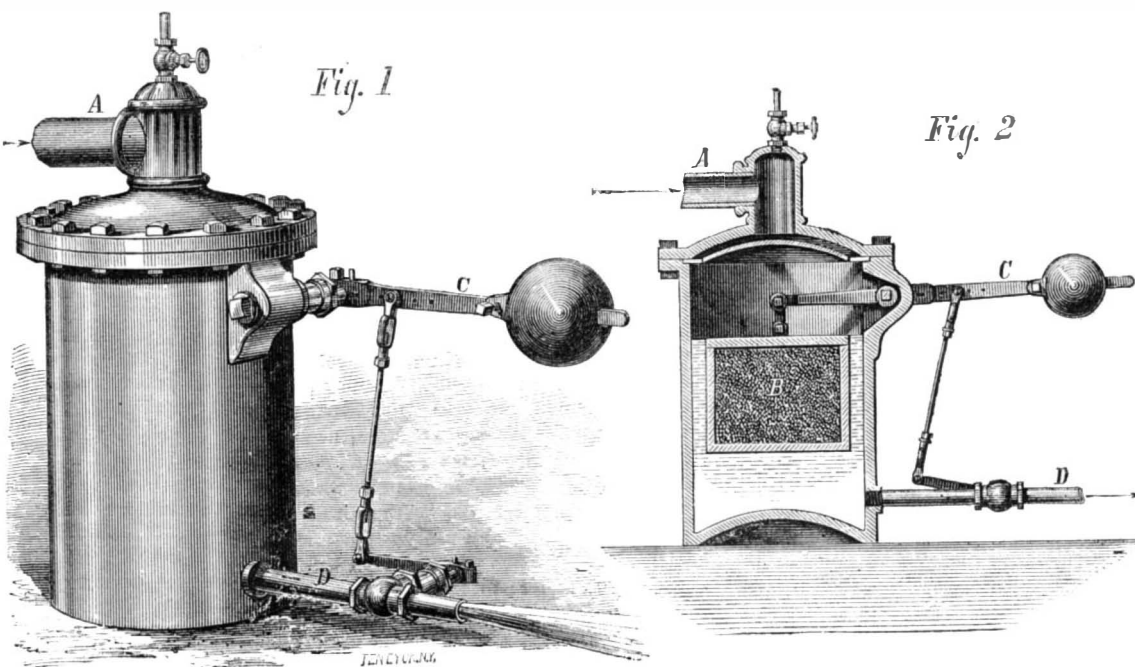

BERRYMAN'S STEAM TRAP.

check valves, and the operation is continued. The latter modification, the inventor states, can be used economically only where the feed water is not heated to a temperature to which it can and ought to be raised by the exhaust. Where this occurs, there are usually pumps of some kind in use, so that the trap in Figs. 1 and 2 can be used. But where there is no engine, and direct steam is used for dry-

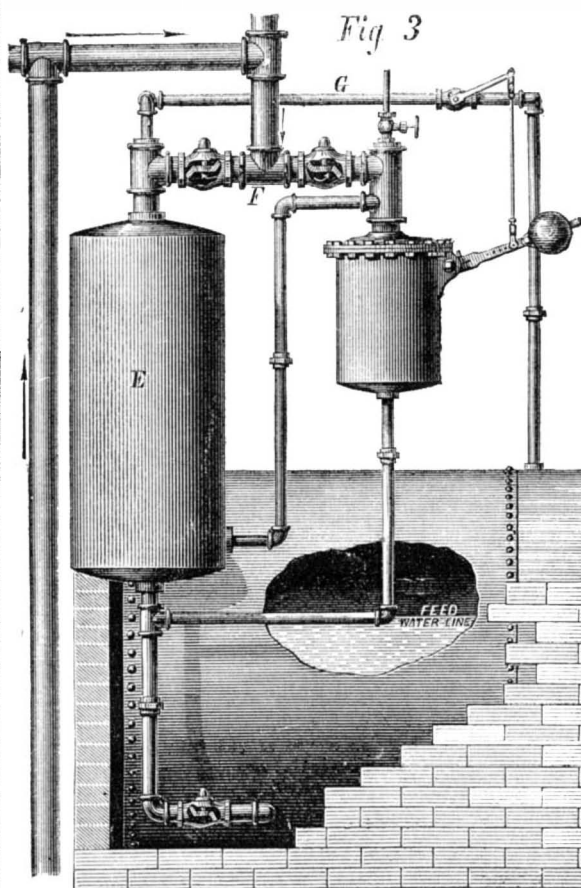

ing or heating purposes, the condensed water may be returned to the boiler with advantage by the latter device, which operates well with any number of coils, which may be situated either above or below the water line.

The Berryman Manufacturing Company, of Hartford, Conn.,

WRITING FLUIDS.

Beyond the act of dipping a pen into an ink bottle, and lifting out a portion of the ink for the purpose of committing our thoughts to paper, we are unacquainted with the composition or mode of production of this useful material.

In a paper read by Mr. Archibald Paterson, before the Glasgow Chemists' and Druggists' Association, Glasgow, the various substances used in writing were treated on, as well as the processes by which writing fluids are produced. He said:

The writing fluids of the present day are the result of our commercial requirements, and are altogether unlike, in composition and properties, the ink of the ancients. They wrote; but their ink was what we should term a varnish or paint, being composed of carbon in very fine division, say either ivory or lamp black, held in suspension by any drying oil which was most approved of, or mixed with glue after the manner of Chinese ink, which requires to be dissolved in water before being used. The ingredients were combined by being rubbed together between stones, as we see painters of the present day grinding their paints. We are even told that the pleasing process of grinding was in schools placed as a punishment on the most indolent; or, failing this, the poorer scholars were pressed with the honorable task of keeping the school in ink. There can be no doubt that the carbon contained in these inks, and which is well known to possess peculiar properties of durability, is the cause of the fresh and black appearance which many ancient manuscripts retain, even after several centuries, while those written by our grandfathers fifty or sixty years ago have in many cases almost disappeared. Even the best modern ink in that time shows decided symptoms of old age.

From the care taken in the formation of the letters in the ancient manuscripts, it is very evident they were not written in a hurry; neither indeed could they be, seeing that the pens used were small brushes, and the ink itself a varnish.

To produce a good modern ink, we must bear in mind certain qualifications, namely, a good ink ought to be so thin as to flow freely from the pen; it should be so thick as not to spread or blur on the paper, and it should possess sufficient depth of color to retain its blackness for many years.

Much of the permanency of even an Al ink depends on the material upon which it is written, for if we write on paper which has been bleached with chlorine and the gas imperfectly removed, it has a most deleterious effect on the beauty and durability of the writing.

Concerning the composition of ink: When we look at the usual source, namely, galls, one would at first imagine that gallic acid wrought a most important part in its manufacture, but such is not the case. The galls are used in the process, not because they are rich in gallic acid, which they are not, although it is from them we obtain most of the gallic acid of commerce, but because they contain a high percentage of tannic acid.

The proportions which appear most suitable, and upon which most dependence can be placed, are—bruised galls, one pound; to this add one gallon of boiling water, and one third of the weight of the galls, namely, five ounces and a third, of sulphate of iron in solution; also three ounces of gum arabic previously dissolved, and a few bruised cloves or a few drops of creosote or carbolic acid dissolved in methylated spirit. It is better to allow the galls to macerate for twenty-four hours, then to strain the infusion, and add the other ingredients.

I cannot do better at this part of the subject than offer you a formula used and recommended by that eminent chemist, the late Dr. Penny, of Anderson's University, in Glasgow.

Take of bruised galls twelve ounces, macerate for a week in one gallon of cold water, then add six ounces of sulphate of iron in solution, also six ounces of mucilage of gum arabic, and five or six drops of creosote.

The learned doctor has here taken advantage of a fact well known to chemists—namely, that tannic acid is more soluble in cold than in hot water—hence the cold maceration is prescribed, which I believe is pretty generally employed by first class ink manufacturers.

The celebrated blue-black ink prepared by Messrs. Duncan, Flockhart, and Company, is said to be made by the process of cold maceration. A formula, said to be theirs, of which the following is a copy, was printed and circulated some years ago by an English gentleman. It explains the process more fully:

RECIPE FOR PREPARING BLUE-BLACK WRITING INK,
(Which also serves well for Copying Ink.)

Blue Aleppo galls (free from insect perforation)	4½ ounces.
Bruised cloves	1 dram.
Cold water	40 ounces.
Purified sulphate of iron	1½ "
Pure sulphuric acid (by measure)	35 minims
Sulphate of indigo (in the form of a thinnish paste, and which should be neutral, or nearly so)	¼ ounce.

Place the galls, when bruised, with the cloves, in a fifty ounce bottle, pour upon them the water, and digest, often daily shaking for a fortnight. Then filter through paper in another fifty ounce bottle. Get out, also, the refuse of the galls, and wring out of it the remaining liquor through a strong clean linen or cotton cloth into the filter, in order that as little as possible may be lost. Next put in the iron, dissolve completely, and filter through paper. Then the acid, and agitate briskly. Lastly the indigo, and thoroughly mix by shaking. Pass the whole through paper. Just filter out of one bottle into the other till the operation has been completed.

• On a large scale, this fine ink may be made by percolation,

as Duncan, Flockhart, and Company and others in Edinburgh do it, the above being said to be their recipe.

The weights used are avoirdupois, and the measures used are apothecaries' measures.

Note.—No gum or sugar is proper, and on no account must the acid be omitted. When intended for copying, 5½ ounces galls is the quantity.

You will observe that there are several peculiarities about this writing fluid, namely:—First, the cold process is used. Second, the want of gum. Third, the use of sulphate of indigo, which is a solvent for the black precipitate, the tannogallate of iron; hence the gum arabic is not required, as it is only used to suspend this precipitate. Fourth, the deficiency of iron, which may be accounted for by the pure protosulphate being used, which cannot contain, or should not contain, any oxide, so that all the iron is free to combine with the tannin. Fifth, the use of free sulphuric acid, which is generally looked upon as detrimental to writing fluids, but which must be introduced here for some purpose, of which I am as yet ignorant.

Thus far I have only spoken of high-class inks, but it frequently occurs that an article is required to be sold at a cheaper rate than that wholly made from galls; and the vegetable world gives us an ample range of materials to select from, many of which contain tannin in fair quantity.

In this case other ingredients may be substituted instead of part of the galls; thus we often see logwood substituted, and catechu, sumach, and oak bark may be used for the same purpose. Many other substances, such as elm wood, elder, chestnut, beech, willow, plum, cherry, and poplar, all contain a certain amount of astringent properties, but none of them are to be compared to galls, and are not likely to supersede them in the manufacture of ink so long as galls can be had for anything like a fair price.

Let us now glance at the properties of the various ingredients used in the process. If we use an excess of galls, we simply throw away money, and render the ink more liable to mold. If we use an excess of iron, the galls being insufficient to decompose it, the characteristic color of its oxide is soon shown by the writing becoming brown. The use of an excess of gum causes the ink to clog the pens, and the writing to be wanting in fluency. About twenty-five years ago an ink named Japan ink was very much in use; it produced a beautiful glossy appearance when written, but clogged the pen so much that it soon fell into disuse; its defect was too much gum. The water should be as soft as possible—that is, it should contain no lime or other earthy matter; hence rain water, or, better, distilled water, is frequently prescribed in recipes for making ink. The cheapest ink which has hitherto been introduced is one composed of a saturated solution of logwood obtained by boiling twenty-two pounds of logwood in a sufficiency of water to produce, after being strained, fourteen gallons of liquor; to this decoction one pound (avoirdupois) of yellow chromate of potash (not bichromate) is added in solution; the proportions are one thousand parts of solution to one of chromate; the change of color is not an immediate one, but gradually becomes darker. The experiment may be tried, on the small scale, by using logwood, a quarter of a pound boiled in water to produce two pints, to which, when strained, add twenty grains of chromate of potash in solution.

We will now glance at the composition of "writing fluids" used for special purposes; thus we know that writing which is intended to be copied is written with ink containing either gum sugar, treacle, glycerin, or some such substance which causes the writing to retain moisture, so that a copy of it may be produced even after the original writing has become dry, by being simply damped and pressed.

The following formula requires no press, but may be copied by placing a damp sheet of copying paper on the writing intended to be copied; above this sheet of copying paper a sheet of ordinary writing paper must be placed, and then pressed with a paper knife.

COPYING INK.

Mix—Thirty grains of extract of logwood; seven grains of crystal soda; half an ounce of water. Boil till dissolved; then, while stirring well, add thirty grains of glycerin, one grain of chromate of potash, previously dissolved, and four grains of powdered gum arabic.

INDESTRUCTIBLE INK FOR DEEDS, ETC.

Dissolve twenty-five grains of powder gum copal in two hundred grains of lavender oil, by the aid of a gentle heat; then add two and a half grains of lamp black, and half a grain of powdered indigo.

Another for the same purpose.

In eighteen ounces of water, boil shellac, two ounces, and borax, one ounce; when cold, filter and mix with one ounce of gum arabic dissolved in two ounces of water, to which add powdered indigo and lamp black as much as may be required.

RED INK

is commonly prepared by boiling brazil wood, two ounces, in thirty-two ounces of water, to which add, after the decoction has been strained, half an ounce of chloride of tin, and one dram of powdered gum arabic; then evaporate to sixteen fluid ounces. Or:

Dissolve carmine, one dram in half a dram of liq. ammonia fort. (sp. gr. 880), then dissolve twenty grains of powdered gum arabic in three ounces of water, which add to the dissolved carmine.

BLUE INK

may be prepared by dissolving two or three ounces of sulphate of indigo in a gallon of water; or by rubbing together one ounce of oxalic acid, and two ounces of fine Prussian blue, to which add one quart of boiling water.

INK POWDER

may be prepared by mixing—Powdered galls, four ounces; powdered sulphate of iron, one ounce; powdered gum arabic, one ounce; powdered white sugar, half an ounce; powdered cloves, one dram.

To these proportions add of water one quart, and macerate for an hour or two.

Note.—The quantity of sulphate of iron is small because it has been dried, and has thus lost the weight of water evaporated.

INK IN CAKES

may be prepared by evaporating good ink to dryness in shallow dishes, but the best results are obtained by dissolving Chinese ink in water.

MARKING INK.

This substance is so well known that little may be said on the subject. The process is founded on the chemical fact that, by applying heat to a salt of silver in combination with other ingredients, the writing becomes immediately, and should remain, permanently black; the formula of Professor Redwood is a good one:

Dissolve separately—nitrate of silver, one ounce; crystal carbonate of soda, one and a half ounces; mix the solution, and collect the precipitate on a filter; wash well, then introduce the moist precipitate into a mortar, and add eight scruples of tartaric acid; triturate till effervescence ceases; then add of liq. ammonia fort. a sufficient quantity to dissolve the tartrate of silver, to which add four fluid drams of archil, four drams of powdered white sugar, and twelve drams of powdered gum arabic, and make up to six fluid ounces, if required, with distilled water.

CRIMSON MARKING INK

is prepared by adding six grains of carmine to the liquor ammonia of the above formula, but it soon loses its crimson color, and becomes, like other marking inks, a black color.

In conclusion, I cannot lay aside this subject without referring to the beauty, brilliancy, and variety of color produced from aniline, whereby we can procure any shade from the most brilliant scarlet to the most sombre black; and should we at any time be deprived of ink from the present sources, we may rest content that so long as our coal fields yield their sparkling riches, so long may we, without fear, look forward to an unlimited supply of our writing fluids.

Mysterious Influences.

Persons sometimes feel remarkably well—the appetite is vigorous, eating is a joy, digestion vigorous, sleep sound, with an alacrity of body and an exhilaration of spirits which altogether throw a charm over life that makes us pleased with everybody and everything. Next week, to-morrow, in an hour, a marvelous change comes over the spirit of the dream; the sunshine has gone, clouds portend, darkness covers the face of the great deep, and the whole man, body and soul, wilts away like a flower without water in midsummer.

When the weather is cool and clear and bracing, the atmosphere is full of electricity; when it is sultry and moist and without sunshine, it holds but a small amount of electricity, comparatively speaking, and we have to give up what little we have, moisture being a good conductor; thus, in giving up, instead of receiving more, as we would from the cool, pure air, the change is too great, and the whole man languishes. Many become uneasy under these circumstances; "they can't account for it;" they imagine that evil is impending and resort at once to tonics and stimulants. The tonics only increase the appetite, without imparting any additional power to work up the additional food, thus giving the system more work to do, instead of less. Stimulants seem to give more strength; they wake up the circulation, but it is only temporarily, and unless a new supply is soon taken, the system runs further down than it would have done without the stimulant; hence it is in a worse condition than if none had been taken. The better course would be to rest, take nothing but cooling fruits and berries and melons, and some acid drink when thirsty, adding, if desired, some cold bread and butter; the very next morning will bring a welcome change.—*Hall's Journal of Health.*

Slate Quarrying and Manufacture in America.

Vermont is distinguished as the headquarters in this country for the best and most extensive deposits of slates, and the region known as Lake St. Catherine is remarkable for its inexhaustible quarries of argillaceous slate, the commercial value of which is just beginning to be appreciated. From the rude Fairhaven school slates, for cyphering and drawing portraits of the master, this hardened clay has risen to an economical importance that puts it into competition with the choicest marbles. The quarries do not run several hundred feet deep like those of Wales, and are consequently worked with greater facility. Large blocks are blasted out and split with wedges, then raised with derricks, and separated into smaller slabs by deftly directed blows from a wooden beetle. The roofing slate is wet in order to facilitate splitting, the thinly laminated formation rendering the process an easy one with the chisel. It is not expedient to take from the quarry more than can be readily split, as the slate splits more freely when fresh, although it is said that frost will restore the splitting property.

The thickest slabs are readily sawn and planed by machinery. Large, handsome flagstones are prepared by simply sawing. Moldings and other decorative pieces are shaped with tools. A great impetus has been given to the slate trade by the demand which the Chicago fire has created, especially for roofing and tiling. The slate companies interchange pro-

ducts with the marble companies, for interspersing white marble with dark slate for floors. Slate is rapidly taking the place of marble for interior decoration; but so long as our extensive forests remain, we shall not need to substitute it for wood, as the English do. With us it is still a luxury rather than an economy.

For ornamental purposes, the slate, after being properly cut and trimmed, is scoured with pumice stone, then rubbed with powdered pumice stone, and polished with felt. It is now ready to be transformed into marble. The slabs having been prepared, and painted with the groundwork color, they are ready to dip. A vat is at hand, containing water, and we cannot say what else. A man dips a small brush in oil colors, and sprinkles it on the surface; then he fans the water with a palm leaf, and draws the brush through it several times. The oil mixed paint spreads on the surface of the water, like the veining in marble, and the slab being gently raised against it receives the impression. A mere change of groundwork and colors gives the varieties of marble—Egyptian, Spanish, Galway, Pyreneese, etc. The most elaborate work, as for altar pieces, chessboards, and borders, is done by hand. After the application of colors, successive bakings and polishings finish the work. This marbled slate is quite elegant, possessing sixteen times the strength of marble, and scarcely distinguishable from it. The imitation of marble in slate is employed for coffins, caskets, table tops, mantels, billiard beds, lamp stands, and innumerable domestic and ornamental uses. The best workmen here are from Wales, having learned the business in the immense quarries of Carnarvonshire. They are sober, industrious, moral people, provident for the future, noticeably fraternal among themselves, kind, and generous toward all. They take Saturday afternoons for holidays, and make up their hours during the rest of the week. These slates are not inferior in quality to those of Wales. The quarries are comparatively shallow, but more easily worked, and they are too numerous and extensive to be exhausted by a single generation.

The New York Tribune, from which we gather the above particulars, says the Vermont and neighboring slate trade is still in its infancy.

Gas Lighting by Electricity.

A new patent apparatus for the instantaneous lighting or extinguishing of gas lamps has just been successfully tried at Preston, England, and is thus described in the Engineer: "The apparatus constituting the invention looks like a moderate sized globular inkstand of glass, surmounted by a tube of the same material, with a metallic top; and by screwing off the burner, it can be very easily attached to any lamp, chandelier, pipe, or ordinary gas jet. The base or globular portion is filled with a deep red colored liquid—a simple chemical mixture, with no combustible properties, almost without smell, and so cheap that three pennyworth of it will serve one lamp for twelve months. Over this liquid and within the glass tube, there is a plate of zinc, along with a piece of graphite or gas coal, and, between those and a thin coiled platinum wire fixed over the cap of the general vessel into which a gas burner is inserted, galvanic communication is obtained. A pipe, to be screwed to that up which the ordinary gas supply flows, runs through the base of the vessel to about the center of the surmounting tube; pressure brought to bear upon the gas in this pipe causes, by small collateral openings, a simultaneous depression upon the chemical solution which occupies a lower level in two side tubes; the gas occupies the vacuum caused by the displaced liquid, and then ascends to a chamber in connection with the burner; while the displaced liquid is pressed into two side tubes effecting contact with the zinc and graphite, generating galvanic activity, which is communicated to the platinum wire, and excites the catalytic power of the wire, which, when exposed to the ascending jet of gas, results in immediate, almost instantaneous, ignition. Each lamp requires one of these appliances; but, as stated, they are cheap, and the price of the requisite liquid may be termed nominal. The apparatus is virtually self acting; it requires no skilled hands to superintend its operations; it may be attached by a novice; it may be replenished at any ordinary chemist's shop for a few pence per year; it needs nothing but fixing, and then being subjected to the simple action of gas pressure."

The idea of attaching a separate galvanic battery to each gas burner, for the purpose of igniting and extinguishing the gas, may be novel, but certainly it is complicated. The method now extensively in use in this country is much better, and is as follows:

A galvanic battery is placed in the cellar, attic, or other convenient portion of the building, from which wires extend to the gas meter, and also to each gas burner, over the orifice of every one of which a fine platinum wire is arranged in such a manner as to form a part of the electric circuit.

In connection with the battery and wires, two or more telegraph keys or buttons are employed, placed wherever convenience requires. By touching one of the keys, the electric current is made to operate a magnet and lever which is attached to the gas cock, whereby the latter is turned and the gas either let on or shut off. By touching the other key, the electrical current is made to pass through the several platinum wires on the burners, thereby almost instantly heating the platinum up to a nearly white heat and igniting the gas. It is a pretty sight to witness the sudden ignition of the jets of a large chandelier in this way. This plan of lighting, first practically applied by Professor Samuel Gardner, is employed for lighting the great dome and other apartments of the Capitol at Washington. Stewart's store and dwelling and Booth's Theater, New York, and in fact hundreds of build-

ings, public and private, in various parts of the country are electrically lighted in this manner, and the success of the system will now make its employment general.

The Albany Iron Works.

Forty years ago, the amount of finished iron yearly produced in the city of Troy was spoken of in the journals of the day as "the unprecedented quantity of twenty-four hundred tons." At the present time, the manufactures of a single establishment located in the same city annually exceed seventeen thousand tons; thus adding another and striking proof of the immensely rapid growth of our industrial enterprises.

The Albany Iron Works, owned by Messrs E. Corning & Co., is one of the largest manufactories of its kind in the country. Its buildings, which are substantially built of brick, are seven in number, exclusive of store houses, etc., and consist of steam mill, water mill, forges, spike, rivet and nail factories, and machine and pattern shops. The dimensions of the largest, the steam mill, are 350 by 15½ feet.

The rivet and spike factory is one of the most interesting portions of the works. A number of ponderous machines are at work in the middle of the apartment, while at short distances apart along its sides are heating furnaces. Into these are placed the bundles of rods from which the spikes and rivets are to be made, and there brought to a red heat. They are then drawn out, one at a time, and their ends placed within the jaws of the machines. With almost magical rapidity, one hammer working horizontally forms the head, another with two or three blows sharpens the point, and lastly the jaws bite off from the bar the finished spike, which falls into its receptacle below. Rivets are made in a similar manner. This factory produces 68,000 kegs of railroad spikes, 11,000 kegs of boat and ship spikes, and 16,000 kegs of rivets annually.

The machines in the nail factory, 40 in number, manufacture 75,000 kegs of nails per year. The process of making the nails, like that of spikes, is accomplished entirely by a simple and ingeniously devised apparatus. A workman is seated before each machine; at his side is a heap of strips of iron of a width equal to the required length of the nail. Picking up one piece of iron at a time with his pincers, he places its extremity in the machine. Here a bit is cut off and pressed and hammered into shape in almost the twinkling of an eye, while a continuous stream of finished nails pours into the box beneath. In this factory are also the nut and bolt machines, great punches which penetrate the heavy pieces of iron as if they were dough, besides complicated though ingenious apparatus for cutting screw threads, finishing bolts, etc., the whole yearly furnishing to the market over 18,000 kegs of nuts and bolts.

The water mill is a spacious building containing furnaces, rolls and other machines for the manipulation of iron. Power is here supplied by an immense overshot water wheel of 150 horse power; water is also used to run the machines in the spike and nail factories, by means of a 150 horse power turbine wheel. In an apartment adjoining the main building, a large and newly completed horse shoe machine is being erected.

The steam mill and forges are huge edifices filled with a busy crowd and fairly deafening with an overpowering din. Here are six steam engines with an aggregate capacity of 700 horse power; besides a ponderous six tun steam hammer. There are also two squeezers, fifty puddling and heating furnaces, several merchant trains, and four cementation furnaces. In the manufacture of car axles, which is largely carried on, two powerful helve hammers are used. The number of men and boys employed is seven hundred. In addition to the products already alluded to, for information concerning which we are indebted to Mr. J. Keyes Paige, of the works, the establishment sends to the market, yearly, some 16,000 axles, 500,000 fish bars and about 1,000 tons of safe and cultivator steel.

Specialties of some Tanning Materials.

Beech bark.—The tannin yielded by this bark makes a white but inferior leather, and is used only in places where oak is scarce.

Birch bark.—For tanning Russia leather, the inner bark is much used, especially on account of the brown oil which it yields, to which this leather owes its smell and durability.

Catechu.—This material produces leather, which, according to Professor H. Dussauce, "is very permeable to water, light and spongy, hard, and of a dark, reddish fawn color. The characteristic deposit, from oak bark and a few other tanning agents, known as bloom is not produced by catechu."

Divi divi.—Leather prepared by this substance is very porous, and sometimes tinged brown, unless the air be excluded in the process of tanning.

Hemlock bark, in union with oak bark, is supposed to produce the best leather. Hemlock alone produces leather inferior to that prepared with oak bark, and besides, imparts to it a red color. In America, it is largely used as a substitute for the bark of the oak.

Lombardy poplar imparts a fragrant smell to the leather, similar to that of Russia leather.

Valonia.—Leather prepared by this substance is harder and less permeable to water than that made with oak bark.

Willow bark (Salix alba) is remarkable for its astringent taste. Leathers made from kid and lamb skins owe their agreeable smell to this bark, with which they are tanned.

From experiments made in the tanning of calf skin with oak bark, divi divi, and catechu, in Germany, and published in the memoirs of the Société d'Encouragement of Berlin and the Technologist, it appears that oak bark and divi divi were shown to be the best, and that divi divi can be com-

pared with the oak. The report states "the use of catechu as a dry matter in the tanning of skins is inadmissible. The porous and thin texture of the leather thus manufactured is a poor guarantee against dampness, and permits of little duration.

"For the expense, there is little difference between oak bark and divi divi. Divi divi, it is true, is more costly; but as it possesses six times as much tannin as oak bark, the balance will be rather in favor of the latter.

Trials were also made with green Buenos Ayres hides, and the result was about the same as above. The divi divi is superior to catechu, and can be compared to the oak in many respects, but it requires more care in its use on a large scale, while the operation is one third shorter."

Liability of Telegraph Companies.

An important legal decision was announced at the last term of the law court in this district, which settles the law in this State as to the liability of telegraph companies to their employers in case of failure to transmit or deliver messages. As the case (George W. True et als. against International Telegraph Company) is of novel impression in our courts and of interest to the public, we give a brief statement of the facts. In 1870, George W. True & Co., of this city, sent a dispatch to their correspondents in Baltimore, accepting an offer of a cargo of corn at a given price and freight. The offer had been made by telegraph the same day, and the reply was sent on a "night blank" of the International Telegraph line at the usual night rates. The dispatch, on account of the carelessness of some operator on the line west of Boston, was not duly forwarded, and True & Co. failed to secure the cargo of corn. As the market price of corn and freights advanced immediately, they were obliged to buy other corn to meet the wants of their business at a price largely in advance of that offered. A claim was immediately preferred against the telegraph company for the damage resulting from their failure to promptly transmit the message to its destination, which was resisted by the company on the ground that one of the conditions printed on their "night blanks," subject to which the message was sent, was that the telegraph company should not be liable, in case of failure to deliver the message, to an amount greater than the sum paid for its transmission—in this case, forty eight cents. Suit was therefore brought to recover special damages; the case was argued July, 1870, and has been under consideration two years; the court has now rendered a decision in which the claim of the plaintiffs is sustained in full.

The ground of the decision was that, although telegraph companies may establish reasonable rules for the conduct of their business, they cannot by printed notices on their blanks relieve themselves from the liability which the law imposes on them from motives of public policy; that the courts are to determine in the last resort whether the rules and limitations prescribed by the company are reasonable, and that the condition set up in defense in this case was not binding upon the plaintiffs, as it attempted to relieve the telegraph company from all liability (beyond the amount paid for the message), whether arising from carelessness, accident or wilful default of the company and its servants. The measure of damage was declared to be the difference between the price of the cargo offered and of that bought to supply its place, with the additional freight.—Portland (Me.) Press.

Magnetism.

The French Academy of Sciences has received a paper from M. J. Jamin, in which he shows that magnetism may be condensed, just like electricity. Having, for some special purposes, had a large horseshoe magnet made, consisting of ten laminae of perfectly homogeneous steel, each weighing ten kilogrammes, he suspended it to a hook attached to a strong beam, and, having wound copper wire around each of the legs, which were turned downwards, he put the latter into communication with a battery of fifty Bunsen's elements, by which means the horseshoe might be magnetised either positively or negatively, at pleasure. The variations were indicated by a small horizontal needle, situated in the plane of the poles. There was, further, a series of iron plates, which could be separately applied to each of the laminae. Before attaching any of the latter, the electric current was driven through the apparatus for a few minutes and then interrupted, whereby the magnet acquired its first degree of saturation, marked by a certain deviation of the needle. One of the iron plates (usually called "contacts") was then put on, and it supported a weight of 140 kilogrammes. A second trial was now made; and the current having passed through again for a few seconds, it was found that the horseshoe would support 300 kilogrammes, instead of 140. The number of contacts being now increased to five, which together, in the natural state, supported 120 kilogrammes, it was found, after the passage of the current, that they could support the enormous weight of 630 kilogrammes, which they did for the space of a full week. No sooner, however, were the contacts taken off than the horse hoe returned to its usual permanent strength of 140 kilogrammes. This leads to show that magnetism may be condensed like electricity for a short period.

ON THE SPECTRA OF SULPHUR.—In the spectrum obtained in a closed Pluecker tube with the spark, says G. Salet, thirty two bands were measured. In the blue flame seen when hydrogen, made with sulphuric acid, strikes against a cold surface, the blueness of which is due to sulphur, twenty five bands were measured, eleven of which coincided with the former. The vapor of sulphur at a low red heat, examined by transmitted light, gave six bands.

DOUBLE TURBINE WATER WHEEL.

Fig. 1 of our engravings gives a perspective view, and Fig. 2, a detail vertical section of what is known as the "Eclipse" double turbine water wheel. We will at once proceed to de-

of which are now in successful operation in the United States, Mexico, and Japan. Patented March 24, 1868, and July 26, 1870, and a patent on recent improvements has just been allowed. For further information, address the Stillwell & Bierce Man-

passes up through the brace, B, the crossbar, C, and the beam, A, where it is secured by a nut. The pivot of this standard passes through the brace, B, and into the central hole in the metallic bar, F. This peculiar connection of the central standard with the other parts is shown enlarged in Fig. 3. It

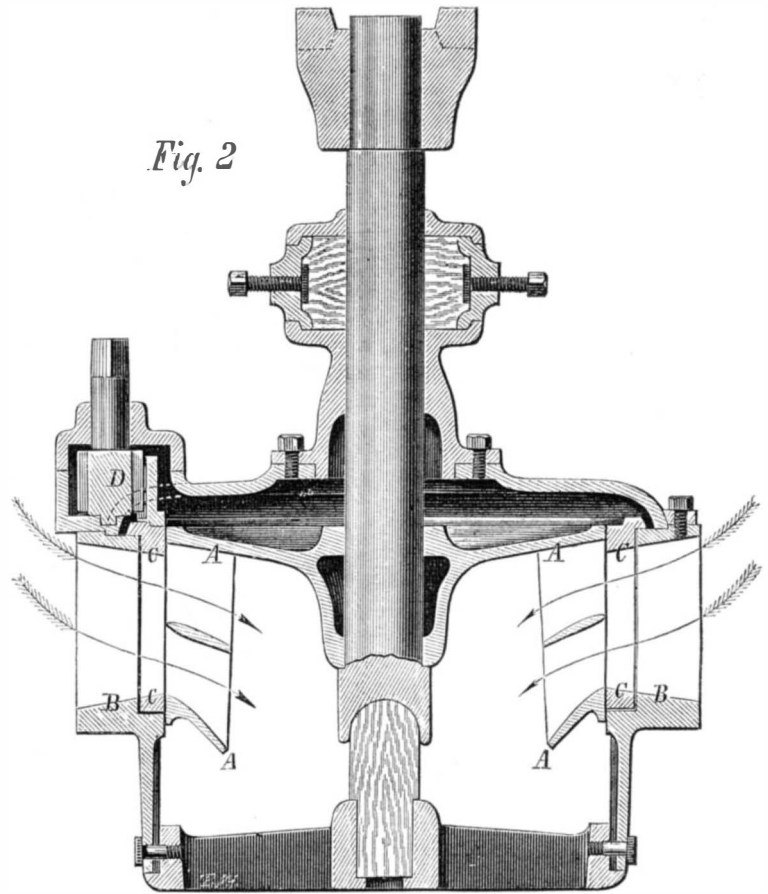
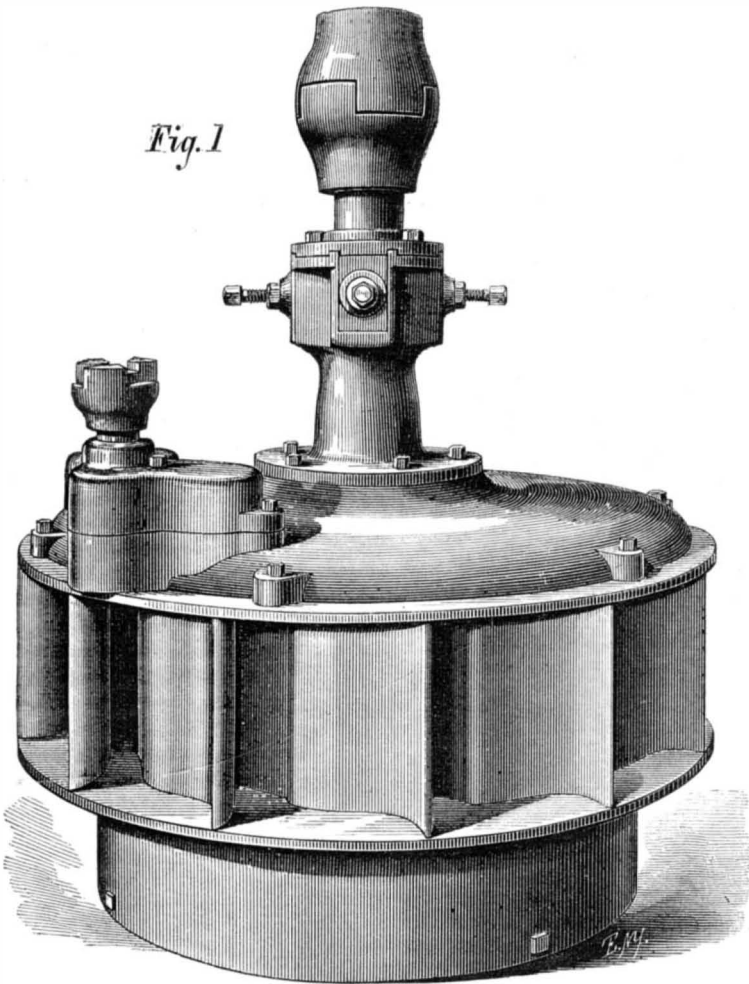

DOUBLE TURBINE WATER WHEEL.

scribe its construction, and point out the advantages claimed for the same.

The wheel, A, Fig. 2, is composed of two tiers of buckets, as shown in the engraving, arranged alternately between three plates of different degrees of inclination, and which have an inward and downward discharge. It is cast in one piece and without cores, thus insuring great strength. It will be noticed that the interior of the wheel is somewhat of a conical form, by which construction a free vent for both tiers of buckets is provided. The cylinder, which supports the bridge tree, and the outer chute case are both comprised in one casting, shown at B. This cylinder and chute case are more fully represented in Fig. 1, from which the form of the outer chutes will readily be understood. The inside register gate, C, is also cast in one piece, with fixed water ways corresponding with the chutes in the outer case. The two combined form one duplex chute. This gate, C, hangs upon the outer case by one bearing only, as shown, and is moved, for the purposes of admitting and shutting off the water, by means of a segment and the pinion, D. By its operation an equal delivery of the water on to all parts of the wheel is secured; neither the direction of the current, nor the angle formed by the steam and the face of the bucket is ever changed, nor is the velocity of the water checked. The top of the wheel case, also a single casting, extends over the register gate, and is fastened by set screws to the outer chute case. This arrangement protects the gate from vertical pressure and renders the movement of it very easy. It may readily be operated by a governor. Facility of access to the wheel in case of accidents is also afforded, as by simply removing the set screws the top becomes detached and the wheel can be taken out of the case without disturbing the latter. It will be noticed that the pinion and segment by which the gate is operated are completely housed, so that they are protected from breakage by foreign substances getting between the teeth. The arrows in Fig. 2 indicate the course of the water through the outer chutes, the chutes of the register gate, and the upper and lower buckets of the wheel. A pedestal, with stuffing box and followers as represented, surmounts the wheel case and is fastened thereto by set screws. The arrangement, as shown, of the spider or bridge, by which the step for the wheel shaft is held, the hub of the wheel, and the stuffing box, is claimed to be such as to secure perfect steadiness of motion with the least possible friction and great strength and durability.

In the manufacture of this wheel, every part of the wheel and case is fitted up by machinery to standard gages, so that all parts can be readily duplicated. These parts are few in number and of great strength, while there is an entire absence of rings, bolts, bars, or traps of any kind which would be liable to derangement or breakage. Great general superiority, therefore, is claimed for these wheels, a large number

manufacturing Company, Dayton, Ohio, by whom the wheels are made, and who have a properly constructed testing flume in their works for testing each wheel before delivery.

ADJUSTABLE PLOW.

The improved plow, which forms the subject of our illustration, is the invention of Glover G. Foreman, of Stockton, Georgia, and was patented through the Scientific American Patent Agency, June 18, 1872. By means of a simple and ingenious device, it is rendered adjustable so as to be set to make the furrows various distances apart, without ever throwing the plows out of parallel.

Fig. 1 is a perspective view of the plow; A is the beam, B is a brace, attached to the beam as shown; C is a crossbar, and D is a semicircular metallic bar pierced with holes as represented. The plows, which may be of any desired kind, are secured by sockets and pins to the standard, E. The forward parts of the upper ends of these standards extend upward in the form of bolts, and the rear parts of the same are

will readily be seen therefrom that the standard is thereby securely fixed in position, while the crossbar, C, is free to move around its bolt when loosened, and the metallic bar, F, around its pivot. By the construction described the parallelism of the three plows is not affected by the angle at which the crossbar, C, is placed to the beam, A, as will be seen by inspecting Fig. 2.

The adjustment of the plows, to work closer together or further apart, is readily effected by loosening the nuts of the standard bolts, and by bolting the semicircular bar, D, through the proper hole to the rear end of the beam, A. By tightening up the standard bolts again, everything is made secure for work.

Further information may be obtained by communicating with the inventor at the foregoing address.

Old and New Ideas in Astronomy.

Theories have been advocated respecting the celestial bodies during the last few years, which, new though they seem, and new as the evidence certainly is on which they have been

based, will yet be found in germ, and sometimes sufficiently well developed, in the works of former astronomers. The theory that the globes of Saturn and Jupiter are as heated as red hot iron was advanced by Buffon and entertained by Bailly. The theory that the sun was surrounded by a perpetual aurora was advocated by Sir W. Herschel. Mairan and the elder Cassini held that there is a connection between the frequency of sun spots and the occurrence of terrestrial auroras. Cassini also held the theory that the zodiacal light (which, by the way, astronomers would do well to call simply the zodiacal) is caused by multitudes of minute cosmical bodies traveling round the sun. The younger Cassini believed the rings of Saturn to be formed of multitudes of discrete satellites, as the sands on the sea shore for multitude. The theory of star drift was not indistinctly hinted at by the elder Herschel, while the theory of star systems subordinate to the galaxy was suggested by Lambert and strongly supported by Michell—Michell, that most unfortunate of scientific thinkers, who mathematically demonstrated the existence of binary star systems, the credit of which discovery adds to the already sufficient fame of Sir W. Herschel—Michell, who devised and constructed the very machine for weighing the earth, the credit of whose invention all our text books award to Cavendish.

We might cite other instances, but these will suffice to show with what good reason the students of astronomy in our day might say with Shakspeare:

"If there be nothing new, but that which is
Hath been before, how are our brains beguill'd,
Which laboring for invention bear amiss,
The second hen of a former child!"

THREE Texas gentlemen have made arrangements for inclosing 145,000 acres of land in one body for pasturage.

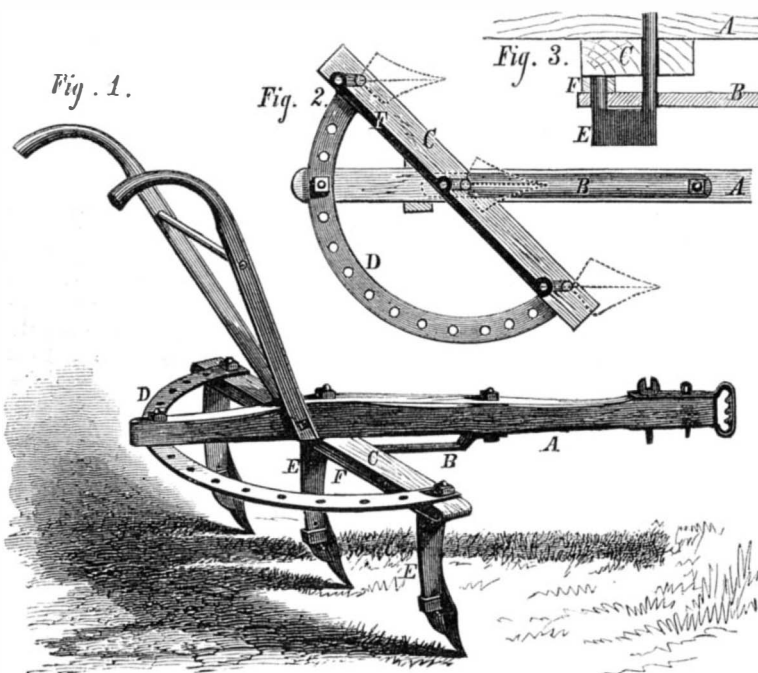

FOREMAN'S ADJUSTABLE PLOW.

provided with upright pivots, in the manner shown in Fig. 3. Fig. 2 shows the under side of the plow frame. The bolts of the two outside standards pass through the crossbar, C, and through the ends of the curved bar, D, where they are secured by nuts. The rear pivots of these two standards enter holes formed to receive them in a small metallic bar, F, which extends along the under side of C, and is shown more clearly in Figs. 2 and 3. The bolt of the central standard

THE CARPENTER BEE.

The name "carpenter bee" has been given to several species of solitary bees who construct their habitations and nests by working in wood, after the manner of the mason bees in earth. The habits of these insects are comparatively well known, but they are not the less interesting.

They usually select posts and the wood work of houses which have become soft from commencing to decay, as their field of operations. The violet colored species, which forms the subject of our illustration, makes her nest by gnawing out small pieces of the wood, which she carries to a short distance and drops for future use, after which she returns by a circuitous route, as if to conceal its location. The direction of the tunnel made by the insect is oblique for some distance, and then perpendicular in the axis of the wood, as shown in our engraving (for which we are indebted to the *Journal of the Farm*), in which the interior of the nest is exposed to view. The entrance hole above is placed at such an angle that the rain cannot enter the perpendicular tube. The opening immediately under the lowest cell serves as an outlet from which the fully developed insect emerges. The tunnel is divided into cells which are separated from each other by partitions made of the chips and dust cemented together. Some other species employ clay for making these partitions. At the bottom of the cell is placed an egg, and over it a paste composed of the pollen of flowers mixed with honey, which becomes the food of the larva when hatched. In a similar manner are completed sometimes as many as ten or twelve cells, one above the other, and then she closes the principal entrance by a sawdust covering, such as the partitions are made of.

Several weeks are occupied in these labors, and the eggs are deposited at considerable intervals. It is therefore evident that the first deposited egg will have become a perfect insect before the last one has passed the grub state, and in order to enable the young to escape as they mature, lateral openings must exist in each cell.

Where sufficient bulk of wood is worked in, sometimes three or four such excavations as described are made.

Tea, Coffee, Cocoa, and Alcohol.

We extract from the *British Medical Journal* the conclusions of a French physician, Dr. Angel Marvaud, who has been experimenting on the physiological and therapeutical effects of coffee, tea, cocoa, maté or guaraná (Paraguay tea), and alcohol, which he classes together as aliments of economy, or anti-waste foods. He considers their influence on nutrition from two points of view: as stimulants to the nervous system, as anti-waste foods or anti-assimilators. Alcohol acts directly on the sensory apparatus of the spinal cord, and indirectly on the motor apparatus. Cocoa acts directly on the motor apparatus, which it excites in the same manner as strychnine. Coffee, tea, and maté act principally on the brain. Alcohol and cocoa excite the exercise of the muscles; coffee, tea, and maté, the exercise of thought. Further, by lessening the waste of the tissues, counteracting organic oxidation, and diminishing loss by means of the secretions, they all act as aliments of economy. In this way is explained their action in stimulating to work in the evening, in partly supplying the want of solid food, and in moderating vital combustion. Hence arises their increasing consumption, and their more general use as articles of daily régime; hence, too, their utility in alimentation, and their important place in hygiene. The abuse of these aliments has, it is true, two principal inconveniences. In the first place, the excitement of the nervous system which they cause is liable to be followed by fatigue, weakness, and even inertia. In the second place, by their interference with and reduction of the processes—indispensably necessary to life—of combination, transmutation, and decomposition, they may cause arrest, suspension, or even complete suppression of the nutritive changes in the cellular elements, and may produce as results, torpor, atony, fatty degeneration, and necrobiosis of the tissues. Thus are explained alcoholism, coffeeism, theinism, and cocoaism.

Fences.

Two thousand millions of dollars is the estimated amount of money invested in fences in this country, which is nearly equal to the total amount of the national debt on which interest is paid, and about the same as the estimated value of all the farm animals in the United States. For every dollar invested in live stock, another dollar is required for the construction of defenses to resist their attacks on farm production. Experiment has proved that at least half this expense is unnecessary. Wherever it has been tried, wherever farm animals are restrained, and their owners are placed under

(fence) bonds for the good behavior of their restless dependents, the system is regarded with general and growing satisfaction; capital is released from unprofitable investment and made available for farm improvement, soiling is encouraged, the manurial resources of stock husbanded, and the way prepared for larger production and higher profit. Even where a herd law of some sort has not been enacted, the tendency is strong, as many correspondents assert, toward the reduction of the amount of fencing; as repairs are needed, division fences are taken down and the material used to keep outside fences in repair; fields are almost everywhere becoming larger; in the younger States, a single field often answers all requirements, and sometimes a single inclosure em-

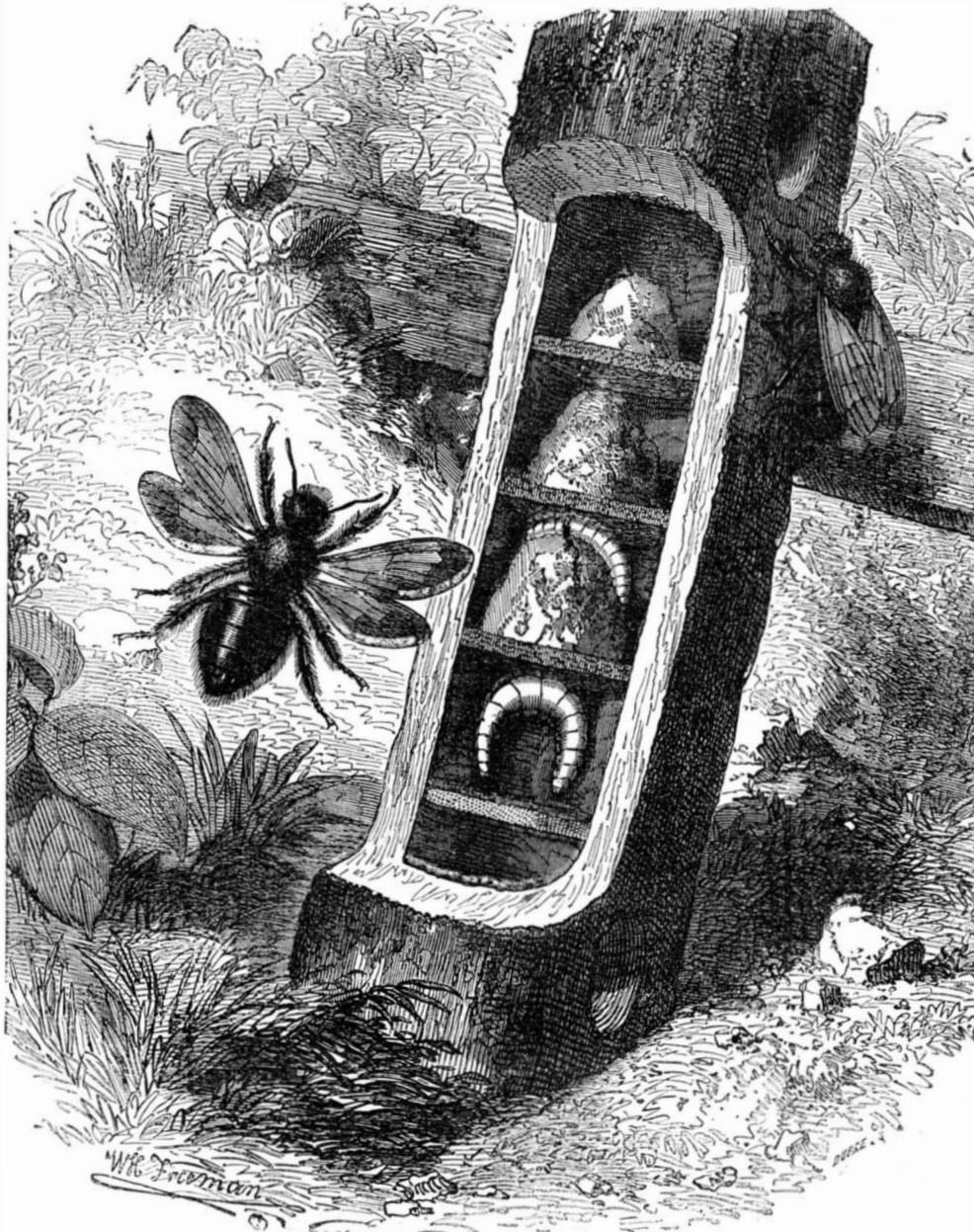

THE CARPENTER BEE.

braces within its bounds many farms. The entire town of Greeley, in Colorado, with its suburbs for gardens and small market farms, is surrounded with a single fence, the cattle being excluded and kept outside upon the illimitable plains. It is possible to dispense with fencing to the value of one thousand million dollars, and the advantages of the change would greatly overbalance the inconvenience of it. Let the farmers discuss the subject in the light of actual experiment, rather than under the influence of ancient prejudice, and their views will soon coincide with their true interests.—*Agricultural Report.*

SIMPLE APPARATUS FOR OUT-DOOR SKETCHING.

Provide a small table with drawer. Mount two grooved movable uprights at one end, with glass between the grooves. Place an upright with a small eye hole, at the opposite end of the table, as shown in the engraving. Wash the glass with a thin solution of gum arabic and rock candy (20 parts of gum to 1 of candy). When the glass is dry, it is ready for use.

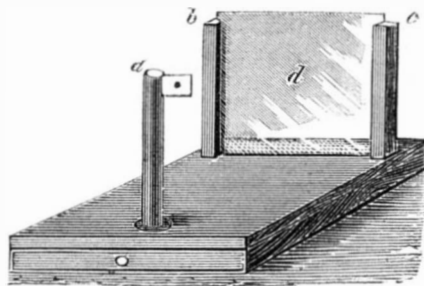

Look through the small hole to get the object or landscape subtended by the glass, and with a soft Paris Conté crayon outline the subject on the prepared surface; remove the glass and lay it over your sketch; if you require the outline, you should have a second plate of glass, and trace over it the reverse way with charcoal, then lay your paper on, and a little gentle rubbing will transfer the outline.

PAPER BOATS--HOW MADE.

The paper boat is a comparatively new invention, and for racing purposes is the most formidable rival of the mahogany and other wooden boats. The process of construction for the paper boats is as follows: A wooden model of the exact size of the required boat is first made from the lines of drawings previously determined upon. This is built of layers of pine fastened together in a solid mass, and its surface is made perfectly smooth. Suitable rabbets are cut to receive the keelson, the two inwales and the dead wood, which, being fitted therein, are worked off even with the surface of the model and covered with adhesive material so as to be attached firmly

to the skin. For covering, two kinds of paper are used, that made from the best manilla, and that prepared from pure unbleached linen stock, the sheets being the full length of the model. If manilla is used, the first sheet is damped, laid smoothly on the model, and securely fastened in place by tacking it to certain rough strips attached to its upper face. A layer of adhesive varnish is then applied, and the sheet laid on, this process being continued until a sufficiently thick covering is obtained. If linen paper be used, but one sheet is employed, of such weight and dimensions (generally from $\frac{1}{2}$ to $\frac{3}{8}$ of an inch) as will, when dry, give just the required thickness of skin. The model, with its enveloping coat of paper, is now removed to the drying room where, at a heat of 150°, the wrinkles in the paper shortly disappear, and the substance hardens in the required shape. The paper is next covered with boiled oil and turpentine and then with shellac varnish, after which it is passed to the intercarpeto put in the frame in the usual manner. The decks are then attached and the iron and brass work complete the fabric.

From examinations made of both wooden and paper boats, of all manner of varying shapes, sizes and workmanship, we are of opinion that the paper shells have a decided advantage. They are both strong and stiff. Their skin is not, as is the case with wood, twisted into an unnatural position from which it is ready at any time to spring. They are thoroughly impervious to water, and cannot become soaked; they are 30 per cent lighter than wood, their lines are equally fine, and they are easily and readily repaired.

IMPROVED SHOPS.

At a recent visit to the Littlefield Stove Works in Albany, N. Y., we noticed several features which might be advantageously introduced in many of the smallest foundries and manufacto-

ries. The buildings, which cover an area of 98,000 square feet, are constructed of wooden frames covered entirely with sheet iron. They are lathed and plastered on the inside, and, as we are informed by the proprietor, answer every requirement as fully as if constructed of brick, while costing far less.

Throughout the works, the utmost care has been taken of the health of the workmen. The buildings with one exception are but one story in height. They are admirably ventilated and lighted with windows placed at a distance of every few feet. There is no hoisting of heavy castings into lofts, etc., material entering the molder's hands in its crude state and passing from room to room on the same level until it leaves the last apartment, perfectly finished.

By means of a tank in the main building an abundance of spring water is distributed throughout the foundry. The blast furnace and molding room is separate from the other buildings, so that all the dirt there made is kept within prescribed limits. The floor of the latter apartment is inclined and thoroughly drained, so that no dampness, a common defect in such places and a fruitful source of disease, can possibly exist.

The grounds around the buildings are tastefully laid out in paths and grass plats, and are as neatly kept as if belonging to a private residence. The center of the space between the buildings is occupied by a tasteful fountain and pond. Another addition, which should be supplied in every similar establishment, is a large swimming bath, to which the hands are constantly allowed access. Fresh water is obtained from a neighboring creek. In winter time, steam pipes are used to heat the bath to a comfortable temperature. Two hundred hands are employed, turning out some 12,000 stoves yearly.

MODIFICATION OF THE BUNSEN BATTERY.—It consists in placing a solution of sulphate of zinc in the porous jars, and pure water in the compartment where the zinc is. The solution of the sulphate of zinc is maintained to saturation point by placing in it a certain quantity of that salt. The current is not very powerful, but it lasts a long while—a month if desired, and the expense is trifling.

Correspondence.

The Editors are not responsible for the opinions expressed by their Correspondents.

Heating and Cooling our Dwellings.—What is Wanted.

To the Editor of the Scientific American:

It has long been to me a source of wonder that better provision has not been made for heating and cooling our dwellings. Undoubtedly hot water is best, steam next, and hot air furnaces last, in order of healthfulness, as heaters. The expense and liability of the two first to get out of order render them poorly adapted for use in private dwellings. In large establishments, such as hotels and factories, where a person can be kept to attend to them, they answer tolerably well; but as it costs from \$1,000 upwards to fit a good sized dwelling with them, and then they require much more fuel and attention than a hot air furnace, it is obvious that they cannot come into general use, and hence we must depend on the furnace.

Now, there are three serious defects in hot air furnaces, which ought to be, and can be, easily remedied.

First. They leak gas. As is well known, the poisonous gases produced by combustion will permeate cast iron when heated to a certain degree. Besides, no matter how well the joints of a cast iron furnace may be fitted and cemented when set up, the subsequent expansion, contraction, and warping of the plates will open the joints and permit the escape of the gas, which, mingling with the heated air, renders it noxious and unfit to breathe.

Second. Their heating surfaces are too small. As a result of this, in order to heat the air sufficiently hot to warm the rooms, the metal of the furnace has to be heated almost, and frequently quite, red hot; and this again greatly vitiates the air, as has been frequently explained by Tyndall and other scientists, and as we all know by actual experience.

Third. They do not contain a sufficient quantity of air. The small quantity used necessitates heating it altogether too hot. It would be far better to use more air and heat it less, as by so doing it would be less vitiated, and the larger the quantity used, the more thoroughly and frequently would the volume of air in the room be changed, and hence be kept much more nearly pure.

The remedies for these evils are plain. First, furnaces should be made entirely of wrought iron, above the fire pot, at least. Second, they should be riveted together, and the points made gas tight, the same as a boiler. Third, the heating surface should be made at least double the present size, and then a larger supply of air furnished. If this were done, and plenty of water supplied for moistening the air by evaporation, hot air furnaces would be rendered far more complete and as healthful as open fires, the rooms, of course, being provided with ventilating flues and registers. It may be that somebody makes furnaces in this way now; but, after examining all I can find and corresponding with manufacturers, I am unable to find such. I have found one pattern in Philadelphia that is of wrought iron, with gastight joints; but it has not sufficient heating surface, and is made with the old-fashioned fire chamber, instead of being provided with a magazine or base burning arrangement, and consequently requires more constant attention. The man who will supply the public with a hot air furnace, such as above indicated, will not only find a large sale for it, but will prove himself a public benefactor. If there is such a man in the United States, I want to find him.

COOLING OUR DWELLINGS.

For years it has seemed to me that it is just as possible and as reasonable for us to cool our houses mechanically as to heat them mechanically. After having experimented on the matter for some years, I am now perfectly satisfied of its feasibility, and that, sooner or later, it will be done. All that is required is to cool a volume or current of air, and force it into our rooms. This can be done very easily. The manner in which I propose to do it is as follows: In a dwelling that I am now building, I am having placed in the walls tin tubes of not less than two inches diameter, extending from the basement all the way up to the topmost story, these tubes having an opening connecting with all the rooms on the several stories, with an arrangement for opening or closing them at pleasure. At the bottom they are connected with a rotary blower operated by a small hydraulic engine, to be fed by the service pipe from the water main that supplies the house. By this means I propose to force into any or all of my rooms a supply of air at any time desired; and this air is to be cooled by any suitable means. It may be passed through a chamber or tubes surrounded with ice or any cooling mixture, and may also be made to pass through a water jet or spray, which will also aid to cool as well as moisten it in a very dry dusty time. If one desires to be luxurious, the water spray may be perfumed, and made to impart its fragrance to the inflowing air; and, as suggested by a friend at my elbow, in the event of a social gathering, a supply of pure oxygen may be provided and forced in with the air, thus elevating the spirits of the company, instead of resorting to the deleterious plan of using champagne and similar liquids for that purpose.

The air should not be taken from the basement nor from near the surface of the earth, especially in summer nights, the time when it is most needed in this latitude, for the reason that all malaria are near the surface at night.

To supply the fan with air, a tube of proper size should be arranged with its upper opening near the top of the house, but not over the roof, because in that case it would receive the air heated by radiation from the roof. Air thus taken from above the surface would also be more free from dust

and impurities, except when in the vicinity of chimneys or factories; and it should be located as far as possible from these, to avoid taking the impure or noxious gases emanating therefrom.

Since writing the above, my attention has been called to an extract from a communication to the *Nation* on this subject of cooling our dwellings. The correspondent proposes to force air into the rooms through tubes, and to cool the air by passing it through small tubes in a box packed with moss or other loose material kept wet by water dripping on it, with a current of air forced through the moss also to cause evaporation and thus reduce its temperature. He proposes to use a large but light bellows to supply the air for the rooms and the cooler, and to operate it by clockwork driven by a weight, to be wound up by a horse once a day or a week, as the case may be.

There are several practical objections to this plan. In the first place, no clockwork can be made with sufficient power to operate a bellows of suitable size for any great length of time. I have built two machines of this kind, and the experiments have satisfied me fully on this point.

To furnish a suitable supply of air, more power will be required than to run a sewing machine. A motor must be used to force in the air, and for this purpose there is nothing equal to the hydraulic engine. As stated in a recent article in the *SCIENTIFIC AMERICAN*, hydraulic motors are the best adapted of any for all such purposes. All cities and large towns are now provided with public waterworks, by means of which they can be operated, and during the night there is always plenty of water, even if not during the daytime.

It has occurred to me that the ether machines recently devised for making ice may be used for cooling the air, especially as they may be made much smaller and cheaper, when used for this purpose, as a much less degree of cold will be required; and on this point I should be gratified to obtain information. Of course it would depend upon the cost of the apparatus and the amount of power required; and as to these, I am not posted.

But that it is as practicable to cool our houses mechanically, as to warm them, I have not a doubt; and it will be done. It is only a question of time and expense, which latter need not be great. A person can stand the heat of the day far better, provided he can secure sound and refreshing sleep at night, and by this means it can be done. It is a disgrace to our civilization that we are compelled to toss about these hot sultry nights, and arise in the morning as weary and exhausted as when we retire at night; and equally so that we should be compelled to fry, stew, and roast in our cells of rooms and offices by day. It is high time there was a reform in this respect, and for one I am determined to have it.

W. C. D.

Washington, D. C.

American Inventions in the Vienna Exposition of 1873.

To the Editor of the Scientific American:

I have read, with much regret, an article in your issue of the 31st ult., intended to discourage American inventors from taking any part in the International Exhibition at Vienna, on the ground that "it is not possible for Americans to compete with Europeans in filling orders for manufactured goods, because the continental manufacturers can do the work much cheaper," and because "our best patterns would be copied without benefit or reward," etc. I think a little reflection will convince you that the view you have expressed is not a very liberal or comprehensive one. A very large portion of our people have come from the German Empire, and thousands more are yearly coming. An opportunity, such as this exhibition will afford to multitudes, to become acquainted with our machinery and inventions will certainly be appreciated by them, and, it appears to me, will more than remunerate the exhibitors, if not a specimen be ever sold in Austria.

But is it true that none can be sold there? Labor-saving machines of American invention and manufacture are now in operation in different parts of the Austrian empire, not in great numbers, it is true; but still the fact remains that they have found a footing there, and are commended by their superiority.

A remarkable interest in our machinery is growing throughout all the Austrian empire and in the surrounding countries; especially are the Hungarians full of admiration for the skill and industry of our people, and I venture the opinion that no part of the Great Exposition will prove as great a source of attraction as the American machinery.

As to the "piracy of inventions," I am glad to have it in my power to show you that your apprehensions are groundless.

By section 38 of the general regulations, which I have heretofore sent you, it is stated that "The chief manager has taken the necessary steps that the objects exhibited may, from the time of their arrival on the exhibition grounds until taken away, enjoy the benefit of the laws existing in Austria for the protection against piracy of inventions and designs—for instance, of the patent and registration laws." Detailed regulations will be published. "Reproductions (designs, photographs, &c.) of objects exhibited are only allowed if the exhibitor and the chief manager consent to it."

By a communication just received from a well known and very estimable American citizen now in Vienna, I learn "that a law was lately passed by both houses of the Austrian Parliament for the protection of foreign objects on exhibition against piracy of inventions and designs. Every foreign exhibitor can apply for a certificate, which secures to him the priority for obtaining an Austrian patent for his article, and such certificate will be issued free of charge."

"Moreover," says the correspondent, "I hear from Mr. Kirch, an American citizen, representing in this city the large manufacturing interest of Wheeler & Wilson in New York, that the Austrian government, in a correspondence with the American legation, is showing a disposition to concede to Americans (in deviation from the existing regulations for patents) the right to import from the United States their articles patented in Austria, without losing their patent, when not manufacturing there." Thus the Austrian government is doing all in its power to favor us.

I think you will agree with me that no fears need be entertained of extended piracy under these liberal provisions; and I am very certain that, feeling so assured, the *SCIENTIFIC AMERICAN* will throw its influence in favor of a large and creditable American representation at the exhibition.

You are also misinformed in regard to the number who are applying to me for space.

I have quite a large number of applicants, including many of our leading manufacturers, and the number is increasing daily.

That Congress made no appropriation is unfortunate; but the opposition of any portion of our press is to me a much greater misfortune. Congress, it is generally believed, will remedy its action in December; but the opposition of the press now will render my gratuitous and laborious efforts on behalf of our industrial interests very difficult, if not entirely useless.

THOS. B. VAN BUREN,
U. S. Commissioner to International Exposition, Vienna, 1873.

Force of Falling Bodies.

To the Editor of the Scientific American:

I see, in an article on page 131 of your paper, that Mr. John W. Nystrom acknowledges himself to be "one of those pretenders" who think that they "understand perfectly the subject" of measuring the force of a falling body by taking, as unit of measurement, the mere weight of matter without motion. I desire here to say to him and to all those interested in the important question of measuring forces, in consideration that force must be distinguished from mere weight, that weight is merely a measure for an amount of matter, for a mere mass, and for nothing else; such weight, of course, is caused by gravitation, and thus can exert pressure, but as long as the weight does not produce motion, there is no force generated; therefore strictly speaking gravitation is no force, notwithstanding the conventional way of speaking of the force of gravitation; however, gravitation can beget force, and only does so in case it is allowed to produce motion. According to the modern conception of force, it is not something immaterial, independent of matter, but absolutely nothing but matter in motion. This motion may be hidden, molecular, when the force manifests itself as heat, electricity, etc., or the motion may be in the masses, when the force is directly measurable by two elements, the mass and the velocity. Accepting the customary symbols for these two different elements, the different degrees of force are expressed by the formulæ $v \times m$ and $v^2 \times m$, which are both correct according to circumstances. In the case of the effect of a blow produced by a falling body, for instance, the driving in of a nail, the identical case represented on page 131, the latter formula, corresponding with the theory of the *vis viva* (see any textbook on mechanics), must be applied. This is the first point in which the formulæ of Mr. Nystrom are faulty, as they are based on the lever, and thus not on the square of the velocity or space, but on the simple velocity: $v \times m$.

The result of this law of the *vis viva* is that, where gravitation increases or decreases, and with it the velocity of the falling body, the force of the blow will increase or decrease as the square of the gravitation, while the weight of the body will only increase or decrease in the simple ratio of the gravitation. Mr. Nystrom's figure and formulæ fail to take any account of this whatsoever.

But let us consider the expressions $v \times m$ and $v^2 \times m$ theoretically. It is evident that they have no value at all as soon as either of the quantities v or m becomes immeasurably small or disappears. Let, for instance, in the function $v \times m$ or $v^2 \times m$, m become $=0$; then we have $v \times 0 = 0$ and $v^2 \times 0 = 0$ which conform to practical experience, because a blow with a mass equivalent to nothing must necessarily amount to nothing. Let, inversely, v be $=0$ and we have

$$0 \times m = 0 \text{ and } 0^2 \times m = 0,$$

again equivalent to nothing; a mathematical proof that a mere mass without velocity (motion) cannot possibly be reckoned equivalent to any force; and we see here the great mistake, thus far made by the authors of many textbooks, in speaking of a force of, say, 100 pounds, or a ton.

The cause of this error is mainly to be found in the fact that a mere weight by its pressure will in some cases produce results similar to that of a force or blow. If, however, we attempt to measure force (matter in motion) by mere weight (matter in rest), we must continually fail and obtain incongruous results, as they are two incomparable quantities. This confounding of an actual force produced by a moving mass with mere weight or pressure produced by a stationary body, is the cause of fifty per cent of the attempts, continually being made by the half educated, to find perpetual motion.

Now for a few practical illustrations: With a comparatively light hammer, we may easily drive a nail into a brick wall; if we try to do it by mere pressure, we shall crush the nail, or, to take Mr. Nystrom's own illustration, we can drive a nail into a board by the blow produced by dropping the head of a hammer on it from a suitable height, directed by guiding pieces, as in a pile driver; but take a similar nail, place it on the same board, attach the lever of proper length and hang the hammer head at the end of the lever, following practically the figure on page 131, and see if the nail will penetrate

at all. If Mr. Nystrom had tried the experiment, he surely would never have taken the trouble to illustrate and publish his explanation.

The blow or percussion gives to a mass a shock, transmitted through it with the same velocity as a wave of sound would travel in that same mass; when the blow is violent and there is somewhere a want of continuity, or lack of strength, which prevents the wave from pursuing its course, its power will be expended there in crushing the material. This is the case in driving a nail. The motion will not be communicated to the board, but the force will be expended in crushing and cutting the fibers of the wood under the nail, so as to allow it to enter, while a weight or pressure placed on the nail will have plenty of time to communicate itself to the whole board. A striking illustration of this may be had when balancing a heavy board on its center; it is then possible to drive a well pointed nail with a smart blow deep in the board without moving the latter, while the same nail with a weight on top will scarcely make a mark on its surface, but will move the whole board. A pistol ball may be fired through a door without moving it on its hinges, which latter may be done by the slightest pressure of the finger. Scores of other familiar examples may be adduced, all proving the immense difference between force and mere pressure, and it is only to be wondered at and at the same time deplored that still so much confusion prevails in regard to this all important subject.

P. H. VANDER WEYDE.

New York city.

To Detect Sulphuric Acid in Vinegar.

To the Editor of the Scientific American:

A few words further in relation to this matter: I never supposed, before, that such an article as that on page 133 of your journal could emanate from the apparently very erudite Dr. Vander Weyde. The process which he denounces as a "gross piece of stupidity" is, to an intelligent, chemist obviously a most excellent method of effecting the desired end; although, it is true, it is somewhat complicated. The process which he proposes is utterly worthless for detecting free sulphuric acid, for any sulphates that may be accidentally present will give precisely the same reaction; these must be gotten rid of, and the evaporation of the vinegar and subsequent extraction with alcohol, as directed in the process which the Doctor so strongly objects to, effects this perfectly, because all sulphates, being totally insoluble in alcohol, are left behind, while the free sulphuric acid is taken up. This alcoholic solution is mixed with water, the alcohol evaporated, and the aqueous solution thus obtained is ready to be tested with barium chloride. The Doctor says the alcohol is added "to destroy the acetic acid by changing it into the volatile acetic ether." This is certainly not so, for the presence of the acetic acid, as he admits, does not interfere with the test; and if it did, the evaporation of the vinegar to the consistence of an extract would volatilize all the acetic acid contained in it. I am sorry the Doctor has thus shown his defective knowledge of chemistry, and if he will be advised by a young pharmacist, he will hesitate next time before attempting to throw discredit upon a journal so ably conducted as is the *American Journal of Pharmacy*.

I will close with a process for detecting the fraud, which is a good one and simple, though not original: Boil a few grains of starch with an ounce or two of the suspected vinegar, for a few minutes in a glass vessel; when it has become cold, add a drop of tincture of iodine. If the vinegar contains no sulphuric acid, a beautiful blue color will be produced by the reaction of the iodine on the starch. But if a small quantity of sulphuric acid be present, no color will be developed, for the acid will have changed the starch to dextrin, which is not colored by iodine.

CHARLES LE R. SAYRE.

Washington, D. C.

Detection of Sulphuric Acid in Vinegar.

To the Editor of the Scientific American:

In the comments of Dr. Vander Weyde in regard to the detection of sulphuric acid in vinegar, the learned Dr. overlooked the main point, that is, the detection of the sulphuric acid and not the salts of sulphates in the vinegar. A great many samples of vinegar which are sold in the market contain small traces of sulphate of lime from the materials which are used in the manufacture, and this small amount will give a precipitate with solution of barium; but it can not be called an adulteration as it gives no acidity to the vinegar.

The adulteration of vinegar is done with sulphuric acid, and to detect such free sulphuric acid the test in the *American Journal of Pharmacy* is based on strict science. The treatment with alcohol will precipitate the sulphate of lime, and the addition of chloride of barium to the filtered solution will show any adulteration with free sulphuric acid.

FRANCIS SCHLEICHER, CHEMIST.

Hoboken, N. J.

Test for Sulphuric Acid in Vinegar.

To the Editor of the Scientific American:

Professor P. H. Vander Weyde, in his strictures on the tedious process, has evidently made a mistake. All that he says applies to acetic acid, but not to vinegar.

Acetic acid (being prepared by distillation) contains neither sulphates nor anything else but acetic acid and water. Vinegar (being prepared from cider, beer, or wine) must always contain extractive matter and earthy salts (generally sulphates). If prepared from diluted alcohol (quick process), in which there is common water, it always contains sulphates. Hence, by adding a solution of chloride of barium to vinegar (made by whatever process), a cloudiness will al-

ways be produced. In order to detect the sulphuric acid in vinegar, we have either to follow the above method with alcohol, or to distil a small quantity and test the distillate with solution of chloride of barium. A third method is to evaporate the vinegar over sugar, on a water bath, till dry; if the residue turns brown or blackens, then the vinegar in question contains free sulphuric acid. Of course, if the vinegar is of a brown color (as cider vinegar usually is), then the third method is unreliable.

H. M. WILDER.

Philadelphia, Pa.

The Risk of Buildings from Fire.

Captain Shaw, of the London Fire Brigade, has published a little book, under the title of "Fire Surveys," which, if well studied and acted on by those engaged in the construction and the guarding of buildings, will, says the *Builder*, save life and property in time to come. If it were desired that we should point out its main purpose, we should say it was to enforce the truth, which has only recently dawned upon legislators and constructors, that iron and stone are not fireproof materials; stone is absolutely inadmissible for stairs, or to support weights internally, and no structure can properly be called fireproof, the ultimate strength of which depends on any metal.

In the whole range of building materials, the writer maintains, there is perhaps none so unsuited for resisting fire as that most commonly in use—stone. It is true that, if embedded in cement or in thoroughly good mortar of lime and sand, it will resist for a considerable time heat gradually applied; but even in such a case it will become calcined, and will crumble to so great an extent as to be unable to carry a load afterwards. In the case of any sudden change of temperature, either from cold to heat or from heat to cold, it cracks instantly without notice, not only leaving a passage for smoke and flame, but in many instances causing the wall to fall. Stone may, however, be used with a certain amount of safety for external walls, but even for this purpose it is very much inferior to bricks.

Walls should be constructed in such a manner as not to separate easily, either from defects in the foundation, irregularity of the loads placed on them, vibration, shocks, or other causes. A wall built of hard bricks laid in sound mortar or cement, and properly bonded, is perhaps the soundest of all for general purposes; but even such a wall is likely to fail on an emergency, if not firmly bonded into a cross wall.

Bond timber in walls is dangerous, as we have long taught, and should not be allowed. When it rots or burns, there is a tendency in the walls to crack. Hoop iron forms a much better bond, and is free from the drawbacks attending the use of wood. Lean-to buildings are dangerous if there are windows in the wall above them. Weather-boarding causes two dangers—one of taking fire from without, the other of conveying fire through the windows. Wherever iron is used, it must be allowed sufficient play for its elasticity, and also for the expansion and contraction which it undergoes unceasingly in consequence of changes of temperature.

Walls may be destroyed by buckling outwards from a thrust, or inwards after the falling of the floors, by inherent weakness, absence of proper ties, and in a variety of other ways; but the principal cause of their "tumbling about," to use a fireman's expression, is undoubtedly, in almost all cases, the want of a proper foundation. The weights carried by different parts of the same wall frequently vary very considerably, and if the ground underneath be all of the same consistency, as is generally the case, some intermediate structure beyond a common foundation is absolutely necessary for buildings liable to be heavily or irregularly loaded. The neglect of this precaution has frequently been the cause of heavy losses.

Copings, balconies, cornices, or other projections should never be constructed of stone, as this material is certain to fall down at an early stage of a fire, and is likely to kill both persons endeavoring to escape and those coming to render aid. Wherever such projections are placed, and whatever material they may be composed of, they should invariably be well supported from the inside, and should be of a weight in proper proportion to the strength and tenacity of the internal supports. Cornices and other projections of the same kind are very dangerous when the internal supports are burned away, and the bond stones by which they are generally fastened to the walls are of no use when the flames are coming out of the windows underneath. This is a point very much neglected in many large buildings, but it is one of paramount importance in connection with fires.

No fireman of large experience has ever seen a stone staircase escape when subjected to much heat; and this being the case, it would seem to be most desirable that there should be introduced a prohibition of the use of stone as a material for lobbies, corridors, passages, landings, or stairs, except where it is supported throughout and not overhanging in any part. We repeat that the use of stone is most dangerous for this purpose, except when it is supported throughout.

SCIENTIFIC AND PRACTICAL INFORMATION.

A NEW ARTIFICIAL MARBLE.

Imitative marble, made by a new process, has recently been introduced in London by Signor Raccotti. In forming the slabs, he commences by laying the veins of color upon a plate of glass, the veins being threads of silk saturated with dyes of the required hues. A semi-liquid cement is then sprinkled upon the glass to the thickness of an eighth of an inch, and is left on the glass to absorb the dye from the silk, the fibers of which are then removed. Cement is added till the slab is of the desired thickness, and twelve hours is sufficient time

for it to become dry enough for the polisher. Its cost is in England about one tenth that of real marble; in this country, the saving would be still greater, especially in large slabs. Two slabs, each five feet square, were recently made in less than three quarters of an hour.

PRESERVATION OF HOPS.

It has been found in Bavaria that hops can be preserved by packing them in a tight barrel between ice. No perceptible change took place in hops which were so packed for a period of seven months.

THE SUNFLOWER.

A contemporary calls attention to the important uses to which the sunflower can be put. It will grow almost anywhere, and the growing plant and its flowers are well known absorbents of foul and miasmatic air. It is very productive of seed, yielding fifty bushels to the acre, which contain fifty gallons of easily expressed oil. The oil is readily burnt in lamps, and gives a clear white light; it can be used as a vehicle for paint, and is excellent for the soapmaker's use. The seeds can also be fed to poultry in winter with advantage. The stalks, which are large and coarse fibered, yield, on burning, a large proportion of potash; but a still more valuable product, a fiber of great strength and smoothness, can be obtained from them by "retting," as is done with the stalks of flax.

MERCURIAL OINTMENT.

M. Lucien Lebeuf prepares this by taking: Ether, 4 grammes, benzoïn, 20 grammes, oil of sweet almonds, 5 grammes, and then mixing, dissolving, and filtering. He adds the mixture to 1 kilogramme mercury, and puts the whole in a glass stoppered jar of five or six times the capacity required by the compound. By shaking briskly and occasionally removing the stopper, the ether will be eliminated, and ultimately the mercury will be reduced to a fine powder. Then the supernatant liquid should be decanted, and the jar shaken vigorously till the mass becomes of an unctuous consistency. The more agitation is used to thoroughly subdivide the mercury, the easier will be the completion of the process, which is effected by taking 920 grammes lard and 80 grammes wax, melting them together in a mild heat, and, when cold, triturating a part with the divided mercury. The bottle should be rinsed out, from time to time, with the decanted tincture, which should be added to the contents of the mortar. If sufficiently triturated, the ether will be entirely evaporated and the mercury extinguished. The remainder of the lard and wax should then be added, and the whole triturated for twenty minutes.

KILLING RATS.

There are many ways of disestablishing rats besides the short and ready methods of poisons or traps, which we find described in a foreign contemporary.

First, there is the old French plan; this is followed chiefly in Paris by men who make it a special business. They take a deep tub with water on the bottom, and a little elevation in the middle like an island, on which is only place for just one rat to sit. The top is covered and has a large balanced valve, opening downward; on the middle of this valve a piece of fried pork or cheese is fixed, and when a rat walks on it to get the cheese, the valve goes down, drops the rat in the water, and moves back in position. A road is made from a rat hole to the top of the tub, by means of a piece of board rubbed with cheese, so as to make the walk attractive for the rats. In the course of a single night some ten, twenty, or even more rats may go down, and if the island was not there, they would be found almost all alive in the morning, quietly swimming round; but the provision of the little island saves the trouble of killing them, because their egotistic instinct of self preservation causes them to fight for the exclusive possession of the island, on which in the morning the strongest rat is found in solitary possession, all the others being killed and drowned around him.

Secondly, we come to the New York plan. The floor near the rat hole is covered with a thin layer of moist caustic potassa. When the rats walk on this, it makes their feet sore; these they lick with their tongues, which makes their mouths sore; and the result is that they shun this locality, not alone, but appear to tell all the rats in the neighborhood about it, and eventually the house is entirely abandoned by them, notwithstanding the houses around may be teeming with rats.

Thirdly, we have the Dutch method, a very cunning device, but probably difficult to experiment about. A number of rats are left to themselves in a very large trap or cage, with no food whatever; their craving hunger will cause them to fight, and the weakest will be eaten by the strongest. After a short time the fight is renewed, and the next weakest is the next victim, and so it goes on until one strong rat is left. When this one has eaten the last remains of any of the others, it is set loose; the animal has now acquired such a taste for rat flesh, that he is the terror of ratdom, going round seeking what rat he may devour. In an incredibly short time the premises are abandoned by all other rats, which will not come back before this cannibal rat has left or has died.

STEAM GAGES.

A test of steam gages was made recently at the show yard of the Royal (British) Agricultural Society, at Cardiff. Sixty-four gages made by different manufacturers were subjected to the tests. Out of these, sixteen were correct; sixteen varied one pound from the true pressure; seventeen, two pounds; six, three pounds; three, four pounds; four, five pounds; and two, seven pounds. If so great a difference was shown in the gages made for exhibition, what must it be in those made for ordinary sale? The *Railroad Gazette* asks: Who will try the experiment on American gages?

ALBANY STEAM TRAP.

In using steam for heating purposes, where all or any portion of the heating apparatus is situated below the water level in the boiler, it is necessary to use a device of some kind for getting rid of the water of condensation as fast as it is formed, as otherwise it backs up in the pipes and stops radiation. In apparatus heretofore contrived for the purpose, water at a high temperature has been allowed to run to waste, excepting where it was sought to return it to the boiler, in which case it was necessary to trap it into a tank and thence, after considerable loss of heat, to force it back into the boiler by the aid of a pump.

The object of the invention now illustrated is to keep the heating apparatus free from water and to effect the restoration of the water to the boiler at a temperature only a few degrees lower than that of the steam itself, by the automatic operation of a simple trap, unaided by pumps or other means. This trap is represented in the accompanying engraving, and its construction will no doubt be readily understood from the same and the following explanation; premising that the three connecting pipes which are broken apart in the engraving are, in reality, extended sufficiently far horizontally to give them elasticity enough to allow the apparatus to operate easily.

It consists essentially of a hollow globe, supported by one end of a lever and counterbalanced by a weight at the other. The topmost pipe is connected with the steam space of the boiler, and is opened and closed to the globe by the automatic weighted valve seen on the top of the same. The larger pipe beneath supplies the globe or trap with the condensed water from the heating apparatus. It is provided with a check valve opening inward. The pipe at the bottom connects the globe with the water space of the boiler, and is furnished with a check valve opening outward. The operation is as follows: When the globe is filled with a certain weight of the condensed water, it overbalances the weight at the other end of the lever, and descends. In descending, it moves the mechanism of the steam valve sufficiently to shift the center of gravity of the attached weight beyond its supporting point, which causes the ball to fall and open the steam valve. The steam pressure closes the check valve in the supply pipe, and allows the water in the trap to flow into the boiler through the bottom pipe, whose check valve opens to let it pass. When the globe has lost sufficient weight through the escape of the water, it is raised again by the weighted lever, and the steam valve is shut by the operation of its attendant mechanism. The condensed water is again admitted by the opening of the check valve in the supply pipe, and the operation is repeated continuously.

The steam valve apparatus is so nicely adjusted that the machine cannot, by any possibility, rest on a center; the valve must always be fully opened or closely shut. An air valve is also attached to the globe, by which the air is expelled.

The inventor estimates that the use of this trap secures a saving of certainly not less than ten per cent over any other method of returning water of condensation to the boiler, where the coils are below the water level. Where the coils are all above the water line, and the return is made by "direct circulation," a large saving is still effected by using the trap, as its action is such as to force a continual circulation without intermission, and thereby to keep the coils nearly up to boiler heat all the time. He claims, as a consequence, that a given space may be heated to a given temperature with one fourth less pipe, by this method, than by any other.

The invention, which was patented by Mr. James H. Blessing, Feb. 13, 1872, has been in satisfactory practical operation in a variety of manufacturing and other establishments for the past year.

For further information, Townsend & Blessing, care of Townsend & Jackson, Albany, N. Y., may be addressed.

A SCIENCE teaches us to know; an art, to do. In art, truth is a means; in science, it is the end.

Lessons from a Brick.

An Austrian *savant* has discovered, by means of a microscope, in a brick taken from the pyramid of Dashour, many interesting particulars connected with the life of the ancient Egyptians. The brick itself is made of mud of the Nile, chopped straw, and sand, thus confirming what the Bible and Herodotus had handed down to us as to the Egyptian method of brick-making. Besides these materials, the microscope has brought other things to light—the *débris* of river shells, of fish, and of insects, seed of wild and cultivated flowers, corn and barley, the field pea, and the common flax, cultivated probably both for food and textile purposes, and the radish, with many others known to science. There were also

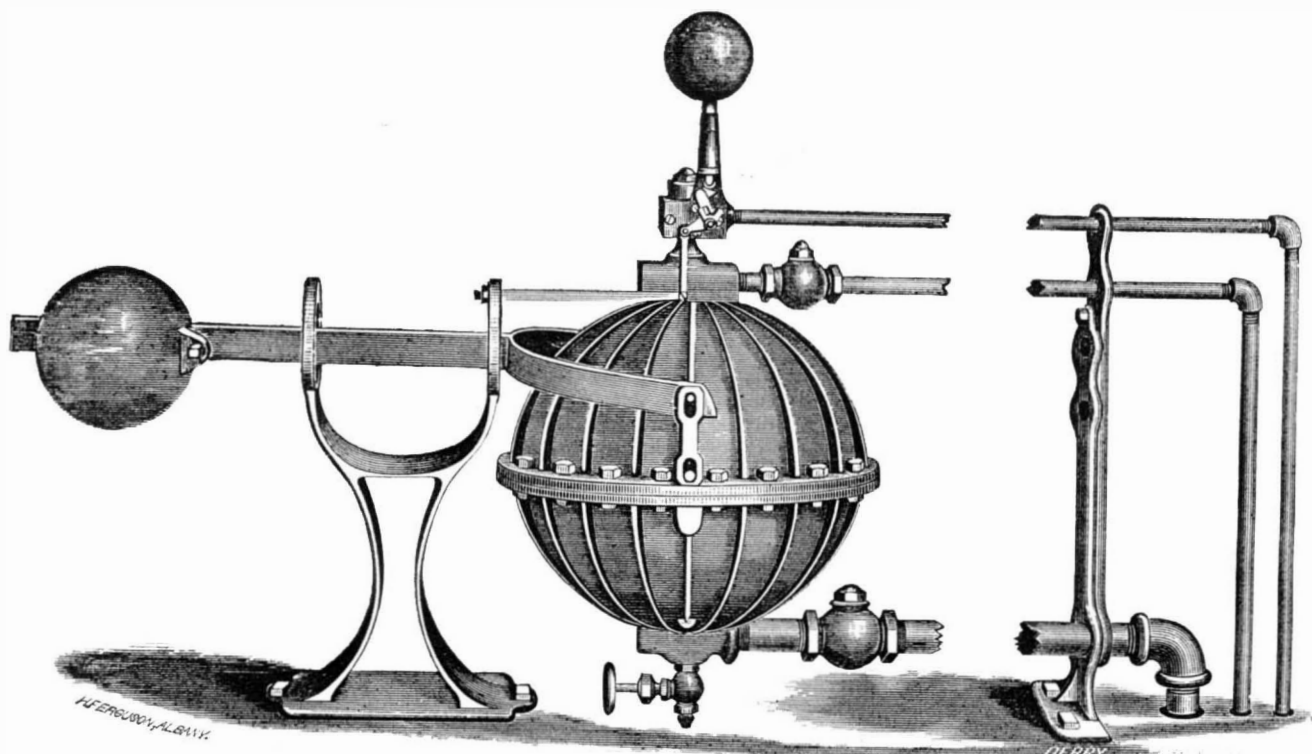

BLESSING'S STEAM TRAP AND FEED.

manufactured products, such as fragments of tiles and pottery, and even small pieces of string made of flax and sheeps' wool.

RAILWAY RAIL JOINT.

The importance of keeping the upper surfaces of railroad rails at their joined ends in the same plane, so that neither shall rise above or fall below the other, and also of furnishing adequate support for the heads of the rails forming the joint, is so well known and has been so often commented on by us as to render a further discussion of the subject in this place unnecessary. The intention of the invention now illustrated is to furnish a joint or support by the use of which both the objects referred to are fully accomplished, and, at

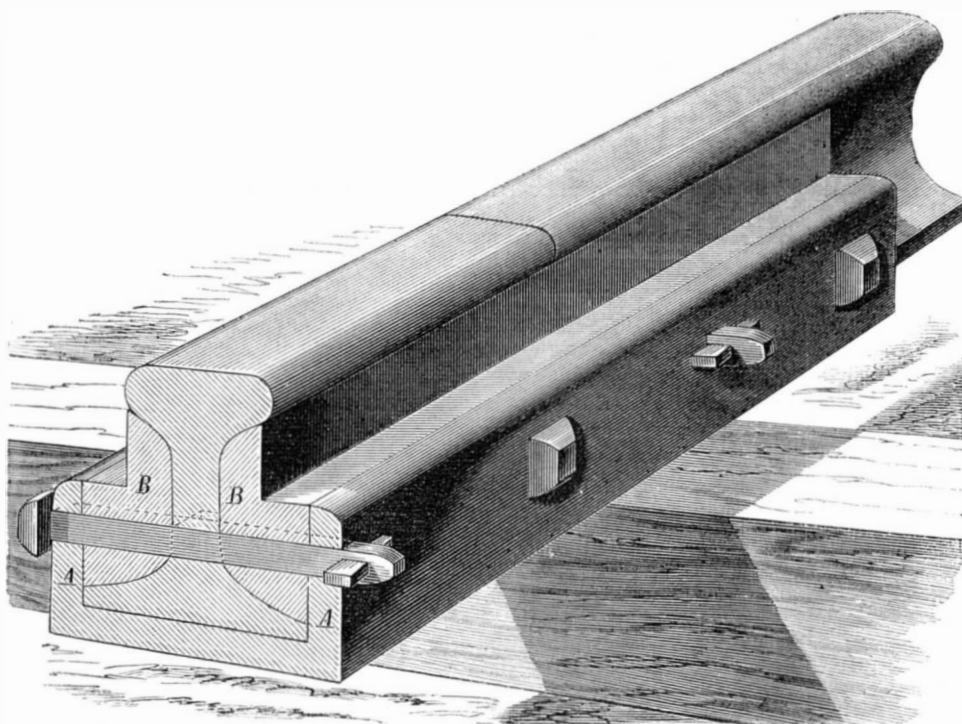

STELL'S RAILWAY RAIL JOINT.

the same time, at a cost insufficient to preclude its practical use.

Our engraving gives a view of the ends of two rails joined by this device, a cross section of the rail and coupling being shown in detail. A is a box which may be made either of cast or wrought iron, the latter being preferable, and of a width sufficient to receive the base of the rail. The length may be as desired; when used to extend over more than one tie, it should be about 18 inches, and the box should be made thick enough to firmly support the rails and prevent any great deflection from the weight of passing trains; when the joint is made upon a single tie only, the length may be reduced to about 8 inches. When the rail ends are placed in the box, the fish bars, B, are inserted between the box and

the rail, in the manner shown. It will be seen that their form is such as to fill up snugly the spaces between the rail and the sides of the box, and that their upwardly projecting parts fit neatly against the under surface of the heads of the rails. They thus form a support for the rail heads throughout the entire length of the bar and preserve the ends, particularly, from being battered down. In order to hold the parts together securely and in proper position, bolts, as shown in the engraving, are passed through the box, the fish bars, and the web of the rail, and are fastened by keys, as represented. The rails are slotted where the bolts pass through, so as to allow for the expansion and contraction consequent on changes of temperature. Round bolts with nuts may be

used if preferred, though the square bolts are less expensive, and where keys are used the parts can be tightened at any time by driving them. They are prevented working out by bending down their small ends.

It is claimed that there is no possibility, by this construction, of the joint getting loose, and that it secures all the advantages belonging to a smooth, continuous rail; for which reasons the liability of injury to either rails or rolling stock is very much reduced. The fastening admits of easy and economic application to rails now joined by the ordinary fish bar.

The invention was patented May 28, 1872, by J. W. Stell, of Gonzales, Texas, of whom

further information may be obtained.

Gasolene, Naphtha, and Benzine more Dangerous than Gunpowder.

Professor C. F. Chandler, in the *American Chemist*, says:—It is not possible to make gasolene, naphtha, or benzine safe by any addition that can be made to it. Nor is any oil safe that can be set on fire at the ordinary temperature of the air.

Special lamps, some of them of very elegant design, have been introduced for burning the liquid gas (naphtha). They are all provided with a reservoir for the dangerous fluid, and a burner by which it is vaporized and burns like gas.

The apathy of the public in regard to this matter is beyond my comprehension. These facts are well known in almost every community, and yet, though it is now twelve or thirteen years since this class of oils came into general use, we have as yet no adequate legislation for the protection of life or property. Nothing but the most stringent laws, making it a State prison offence to mix naphtha and illuminating oil, or to sell any product of petroleum, as an illuminating oil or fluid to be used in lamps or to be burned except in air gas machines, that will evolve an inflammable vapor below 100° Fah., or, better, 110° Fah., will be effectual in remedying the evil. In case of an accident from the sale of oil below the standard, the seller should be compelled to pay all damage to property, and, if a life is sacrificed, should be punished for manslaughter. It should be made extremely hazardous to sell such oils.

Naphtha, under whatever name it passes, is, in one respect, more dangerous than gunpowder. Gunpowder never explodes unless fire is brought to it. Naphtha, on the other hand, sends out its inflammable vapor and brings the fire from a distance. Gunpowder is thus a passive agent, while naphtha is an active one; and when introduced under the treacherous disguise of safe oil, it is not to be wondered that frightful accidents occur.

In this connection the "vapor stoves" demand some consideration. These stoves are supplied with naphtha (sold under various names) from a reservoir at one side, the supply being regulated by a stop cock. The naphtha flows into a tube or chamber, which is maintained at a high temperature by the combustion; here it is vaporized to escape through suitable orifices and burn. These stoves are arranged for cooking, as well as for heating apartments.

These contrivances are all, without exception, highly dangerous. They are all supplied with benzine or naphtha, which is always liable to take fire and to produce explosive vapors.

A keg of gunpowder in a building is not as dangerous as one of these stoves.

Scientific American.

MUNN & CO., Editors and Proprietors.

PUBLISHED WEEKLY AT
NO. 37 PARK ROW, NEW YORK

O. D. MUNN.

A. E. BEACH.

TERMS.

One copy, one year \$3 00
One copy, six months 1 50
CLUB RATES (Ten copies, one year, each \$2 50 25 00
Over ten copies, same rate, each 2 50
TO BE HAD AT ALL THE NEWS DEPOTS.

VOL. XXVII., No. 11. [NEW SERIES.] Twenty-seventh Year.

NEW YORK, SATURDAY, SEPTEMBER 14, 1872.

Contents:

(Illustrated articles are marked with an asterisk.)

Answers to correspondents	170	Patents, recent American and for-	170
Astronomy, old and new ideas in	162	eign	170
*Bee, the carpenter	163	*Plow, adjustable	163
Boilers, formation of scale in	167	*Rail Joint, railway	166
Brick, lessons from a	168	Range, the kitchen	168
Business and personal	169	*Robbery, an astronomical	168
Declined	169	Sand paper	159
Falling bodies, force of	164	Scientific and practical informa-	163
Fences	163	tion	163
Fire, the risk of buildings from	165	Shops, improved	163
Fresco painting, patent system of	169	Sirius, the star	167
Gas lighting by electricity	161	*Sketching, apparatus for out-	163
Gasoline, naphtha, and benzine	166	door	163
Heating and cooling our dwell-	164	State quarrying, etc., in America	160
ings	164	*Steam trap, Albany	166
Influences, mysterious	160	*Steam trap, improved	159
Iron works, the Albany	161	Sulphuric acid in vinegar	165
Magnetism	161	Tanning materials, specialties of	161
Museum, prehistoric	159	some	161
Newark industrial exhibition, the	168	Tea, coffee, cocoa, and alcohol	163
New books and publications	172	Telegraph companies, liability of	161
Notes and queries	170	Terrestrial magnetism	167
Paper boats—how made	163	Thurston, letter from Professor	168
Patented in England by Ameri-	172	R. H.	168
cans, inventions	172	*Turbine water wheel, double	162
Patent office, renewed activity at	168	Vieuna exposition of 1873, Ameri-	164
the	168	can inventions in the	164
Patents, official list of	172	Writing fluids	160

TERRESTRIAL MAGNETISM.

Its influence upon the compass needle. The supposed iron islands of the sun and their effect upon the magnetic currents of the earth.

The compass or magnetic needle does not ordinarily point to the true north, but varies to the east or west, in different parts of the globe. This variation is called the declination of the needle. The declination varies slightly with the different seasons, also with the hours of the day, and forms the subject of scientific observations, made in magnetic observatories expressly built for this purpose in different parts of the world; other magnetic observations are made in regard to the amount of inclination from the horizontal line, called the dip of the needle, which strongly increases when approaching the magnetic poles of the earth, until, on the poles themselves, the needle stands in a vertical position. The line surrounding the earth between the tropics, where the needle is horizontal, is called the magnetic equator; north of this line, the north pole dips; south of it, the south pole dips, until it reaches its maximum dip of 90° or a vertical position, at 74° south latitude and 140° longitude east of Greenwich where the magnetic south pole is situated.

Another element of observation is added also, that of MAGNETIC INTENSITY.

This may be measured by the velocity of oscillation of the compass needle when disturbed from its natural position. It is founded on the same principle as the measuring of the intensity of gravitation in different parts of the earth by the pendulum; where the gravitation is stronger, as is the case at the poles, the same pendulum oscillates faster; where gravitation is less, as at the equator, the same pendulum oscillates slower. It is so with the compass needle; where the magnetic attraction is greater, as is the case near the magnetic poles of the earth, the needle will oscillate faster; where this attraction is less, as at the equator, the same needle oscillates slower.

INFLUENCE OF HEAT AND COLD UPON THE MAGNETIC NEEDLE.

As heat diminishes the magnetism of the needle itself, this has influence on the results, and must be brought into account in the same way as is done in regard to the pendulum, which becomes longer, and therefore oscillates slower, by rise in temperature. For this reason, well constructed magnetic observatories, like that at Toronto, Canada, are entirely under ground, in vaults where the temperature can be kept equal the whole year round.

This decrease of magnetic power by heat may be observed on any compass needle; it oscillates slower when heated, before coming to rest, than when cold. So that heat produces the same result as bringing the needle into a locality where the earth's magnetism is weaker, and *vice versa*. Cooling the needle produces the same result as bringing it into a locality where the earth's magnetic intensity is greater.

ACTION OF THE COMPASS IN A BALLOON.

If we rise in a balloon to a distance from the earth gravitation will become less and the pendulum oscillate slower; terrestrial magnetism also becomes less, and therefore the compass needle should oscillate slower. This might be reasonably expected, and therefore a great surprise was experienced, when it was found that the experiments in France, in the beginning of this century, did not verify this expectation. The compass needle was found to oscillate about as fast at a height of 15,000 feet as near the earth's surface. But the correction had been overlooked; at that height the temperature was so much lower than at the earth's surface that it had increased the magnetic intensity of the compass needle itself about in the same degree as the distance from the earth's surface had decreased the earth's attraction. Therefore, when this cor-

rection for temperature was applied, or the needle tested on the earth's surface at the same low temperature as was observed in the upper regions, it was decidedly found that the earth's magnetism decreased with the distance from its surface, as expected.

EFFECT OF EARTHQUAKES UPON THE COMPASS.

Besides the periodical changes described, the compass needle is subject to irregular motions, caused by earthquakes or volcanic eruptions, of which the effect on the needle will manifest itself over large tracts of country, a thousand or more miles in extent, and always everywhere at exactly the same instant; according to the theory of electric currents as cause of the earth's magnetism, this is easily explained, as such violent disturbances in the crust must necessarily also disturb the currents passing through the same.

EFFECT OF THE AURORA BOREALIS UPON THE COMPASS.

Another disturber of the compass needle is the *aurora borealis*, and this is a deciding proof that this phenomenon is due to electric currents, which, running north and south through the upper rarefied and therefore conducting strata of our atmosphere, of course give a tendency to the needle to deviate to the east or west, as it is then affected by two sets of currents, the stronger steady subterranean current running east and west and causing it to point north and south, and the weaker unsteady auroral current in the upper regions running north and south and attempting to deviate it east and west.

THE ELECTRICITY OF THUNDERSTORMS AND THE COMPASS.

The electricity of thunderstorms has been found not to have any effect on the compass, except when the compass itself was struck and its magnetism reversed, or when a vessel was struck and its iron acquired so much magnetism as to affect the correct indications of the compasses on board.

EFFECT OF SUN SPOTS UPON THE COMPASS.

A most striking fact, however, is the relation of the sun spots on the declination of the needle. It is found that, during periods when the sun shows a great number of spots, the variations of the needle are greatest; and even that at the appearance of a very large spot, the needle was affected at different places of the earth's surface at the same instant. Two explanations may be given for this surprising phenomenon. The first is that the revolving east and west electric currents in the earth's crust, which are the cause of the earth's magnetism, are caused by the solar radiation of heat, before which the earth revolves east and west, and thus must be affected by any change in the solar surface by which this radiation of heat is modified. The second is that the sun contains enormous quantities of iron, which, in the ordinary condition of liquidity and gaseousness, are at so high a temperature as to be beyond the magnetic influence; we know, namely, that white hot iron or steel loses all magnetism, and cannot be affected by any magnet.

ISLANDS OF SOLID IRON ON THE SUN.

If, now, on the solar surface a spot appears, it is probably a solid island in a liquid ocean; and if this island contains as much iron as the rest of the solar body, which is probable, and is several hundred times larger than our whole earth, which is certain, it would be quite reasonable to expect that the sudden formation of such a mass, accessible to magnetic influences, would make itself at once felt here on earth.

THE ATTRACTION OF GRAVITATION AND MAGNETIC ATTRACTION INSTANTANEOUSLY TRANSMITTED.

Astronomy proves, indeed, that the attraction of gravitation does not require time for its transmission, but is transmitted at once through any distance; this appears to be the case also with the magnetic attraction, which in fact is probably only a special modification of the general law of gravitating attraction, which is as wonderful as magnetism; but gravitation is so familiar to us all, from our childhood upward, we take it as a matter of course, while magnetic attraction excites surprise, especially among the ignorant, simply because it is to them a new fact, with which they are unfamiliar.

SUBSTANCES ACTING MECHANICALLY TO PREVENT THE FORMATION OF SCALE IN BOILERS.

Besides the substances which act chemically, like soda ash, chloride of barium, carbonate of ammonia, extract of oak bark, etc., to prevent the formation of scale in boilers, there have been from time to time materials proposed which act either by commingling with the mineral particles, thus retaining them in suspension, or by rendering adhesion difficult. To these latter belong the various paints, about which we shall speak further on. Professor Bolley, late professor of applied chemistry at the Polytechnic school at Zurich, Switzerland, has investigated this subject, and we find in his report much valuable information. Saw dust from mahogany, as well as from coniferous trees, has been used with success. The former acts also chemically, as well as mechanically, owing to the tannic acid it contains. This acid combines with the lime, forming tannate of lime, which deposits itself as a slimy body, without adhering to the walls of the boiler. The saw dust from pine and other similar woods possesses only a mechanical action. Both, however, are soon reduced to a slime, and are thus objectionable for the reason that they are easily thrown by priming between the valves and the packings of the piston, and interfere seriously with their operation.

Clay free from sand has been proposed by a Frenchman, M. Chaix, and has been found to answer well; boilers, in which it was used, were found free from scale two or three months afterward. Still, its use has been discontinued, owing to the fact that the valve surfaces and the interior of the steam cylinders have been found scratched and covered with dirt.

Scrap iron acts not on the sides, but merely on the bottom, which is often much worn by its use.

Among others, starch and sugary substances have been applied. Potatoes have been in use for a long time for the purpose in question. The starch, of which they mainly consist, is soon converted into dextrin or starch gum, whereby the water becomes viscid. Molasses acts in the same manner, as observed by M. Guinon in Lyons (France) and confirmed by Guimet; and both these gentlemen state that for a boiler of 17½ feet length and 8½ feet diameter, 10 lbs. of molasses was amply sufficient to completely prevent the formation of scale for two months. Formerly it was necessary to remove the scale every month from this boiler. Guimet uses six pounds of starch sirup every month in a boiler of eight horse power, with the best success. Steam is kept up in the boiler in question for fourteen hours a day. To the same series of substances belong also dye wood extracts, since they yield glucose when acted upon for some time by hot water. This substance produces the same effects as sugary liquids. Bran and succory root, both of which contain starch, belong to this class. Payen recommends to add to the water in a boiler producing 600 lbs. of steam daily, per month, 9 lbs. mashed potatoes, 3 lbs. molasses, ½ lb. dye wood extract, or, instead of the last named, 3 lbs. of bran. As dye wood extracts contain tannic acid, they will also act chemically, hence the small amount recommended. It may well be supposed that all slimy substances, or such that are rendered slimy, continuously prevent the deposit of the mineral because their smallest particles serve as points of agglomeration and accumulation impossible. But there is one grave objection to the application of all slimy substances. In boilers of somewhat complicated construction, they collect upon parts where the water boils least, adhering there readily to the boiler; and since the water attains through them a higher specific gravity and produces scum, they are readily thrown into the steam pipes and engine cylinders. In spacious and simple boilers, they may, however, render good service.

Fatty bodies and tar serve to diminish adhesion. Spermaceti oil alone, according to Bedford, gives good results. It has been recommended to cover the tubes and parts exposed to the fire with a mixture of 3 lbs. graphite powder and 18 lbs. molten tallow. Newton communicated a recipe for a mass, which is said to adhere still better. It consists of 8 parts tallow or lard, which is first mixed with 8 parts fine graphite (olumbago) and then well kneaded with one part fine charcoal powder, while warm. When it is to be applied, the mass is rubbed together with oil or gas tar. In applying these proposed remedies, it is not to be overlooked that, although only small quantities of fat and tar are rendered volatile by the steam, they may at times become troublesome. Some deny their efficiency entirely, maintaining that scale is formed wherever surfaces are directly exposed to the fire; but others say that this scale is more easily detached. There is here a large and highly remunerative field for inventors, and we hope it will not long remain unexplored.

THE STAR SIRIUS.

The apparent orbit of Sirius, the "dog star," to whose ascendancy the heat of the summer months and the prevalence of hydrophobia at this season have from time immemorial been attributed, is at the present time so near to that of the sun that the star is invisible to us. But although absent from our nightly field of stellar observation, we are continually reminded, by the thermometer and otherwise, of the supposed influence of this body; and a few considerations of its peculiarities will not, therefore, be out of place.

Of the enormous distance of Sirius and the other stars, no adequate conception can be formed; but here statistics come to our aid. It has been demonstrated that, if our sun were removed to the distance of the nearest so called fixed star, it would assume the apparent size of a star of the second magnitude. But Sirius is many times as far from our earth as the nearest fixed star, and its immense separation may be formulated by stating that it is 1,375,000 times the radius of the earth's orbit away from our planet. This radius equals 92,400,000 miles, and the result of the calculation astounds us with its magnitude, and leads us to still further astonishment at the distance of the multitudinous bodies of the nebulae which, when congregated millions together, scarcely suffice, in some instances, to render the aggregation visible to the unaided eye.

Such is the enormous mass of the star Sirius that it has frequently been supposed to be the center of the universe, as far as our powers of research can reach. It is certainly possible that our whole solar system is revolving around this bright particular star, but its obviously increasing distance points out the deduction that the orbit of the system is an eccentric one, and that its center is still traveling away from that part of the heavens with which we are familiar. Of the rate at which Sirius is leaving us behind, it is sufficient to give the results of the best astronomical observation. Mr. Huggins, whose discoveries with the spectroscope have done much to make us familiar with the enormous powers of that invaluable instrument, has found by watching the hydrogen line given by this star that its displacement equals $\frac{1}{10}$ of an inch towards the red end of the spectrum, and he deduces from this fact that the refrangibility of the light of Sirius is much diminished, as the red are the least refrangible of all the colored rays, and this is a complete proof that Sirius is receding from the earth. Then the question arises: At what rate is this retrograde motion taking place? Computation from the spectrum gives it at about 41½ miles per second; but at the time in question, the earth was, by its own revolution, receding from Sirius at the rate of 12 miles per second, and the motion of our whole solar system accounts for an

additional 5 miles per second. This reduces Sirius' retrograde speed to about 24½ miles per second. Further modifying this figure by the result of Sirius' transverse motion, we arrive at 29 miles per second, or 900,000,000 miles per year.

What result does this enormous increase of distance have upon this star, so well known to us in the wintry heavens? Sirius is the fiery red *Sothis* of the Egyptians, and Seneca described it as being redder than Mars. But in these days it shines with a perfectly white light, and it was so even in the days of the Danish astronomer Tycho Brahe. Its rapid recession is thus causing a constantly varying change in its color. Whether any further mutation in its aspect will take place during the lives of our now living observers, it would perhaps be presumptuous to predict; and as to what color it will next assume, we have no guide. At its present rate of travel, it will take 20,000 years to double its distance, and as it is now a star of the first magnitude, almost an infinity of time must elapse before it is no longer accessible to the instruments of modern astronomers.

However, we must believe the effect of the ascendancy of the dog star to be a mere superstition. The concurrence of this event with the hot weather of summer is a mere coincidence, and dogs are effected by rabies and men by sunstroke without regard to the position of Sirius in the heavens. Indeed, the so called dog days, according to the almanac, are over before the star rises with the sun, and thus are twenty days too early to be justified by the theory that caused the ancients to describe them as the *caniculars*. There is no doubt, therefore, that the effects of summer heat will continue long after the power of Sirius in our skies is considerably diminished; and the dog days must certainly be considered as a curious tradition, only important so far as it throws light on the condition of learning among the ancients.

RENEWED ACTIVITY AT THE PATENT OFFICE.—RE-ORGANIZATION AND NEW CLASSIFICATION.—APPOINTMENTS AND PROMOTIONS.

The increasing business of the Patent Office has for some time past rendered the old system of classification of the inventions inadequate, and has occasioned much delay in the business of examination. As a remedy for this state of things, the Commissioner of Patents has very wisely decided to institute an entirely new classification, introducing a large number of subdivisions, which will greatly add to the convenience of all who are connected with the department. Formerly, the inventions were divided into twenty-one classes, each of which was managed by one principal examiner and one assistant. Under the new organization, which went into operation on the 15th ult., the inventions are formed into twenty-two grand divisions, at the head of which is a principal examiner. These divisions are separated into one hundred and fifty classes, or subdivisions, administered by some sixty principal and assistant examiners. The work of re-arranging the drawings and documents of the establishment, in accordance with this new organization, is now going on at the Patent Office, and as soon as it is completed, we may expect to see a marked improvement in the general working of the bureau. Every case will be promptly examined and decided, the tedious delays now too often experienced will be avoided, every part of the business of the establishment being carried on with ease and regularity.

The following gentlemen, who have held positions as second assistant examiners, have been promoted, on merit, to be first assistant examiners:—C. W. Forbes, O. C. Fox, C. W. Chapman, and H. Seymour.

The following have been appointed second assistant examiners:—J. A. Brown, J. B. Church, and R. G. Dyrenforth.

Ed. H. Knight, formerly editor of the Patent Office *Gazette*, has been appointed a principal examiner and placed in charge of the classification, indexing, and official publications.

Professor H. H. Botes, formerly in charge of division B of Agriculture, has been assigned to duty in charge of the class of Civil Engineering, to fill the vacancy caused by the promotion of General Ellis Spear to be one of the Examiners-in-chief.

Major J. C. Woodward has been placed in charge of a new class formed out of the division of the classes of Civil Engineering and Land Conveyance.

AN ASTRONOMICAL ROBBERY.

We regret to learn that the Allegheny Observatory, Pittsburgh, Pa. has suffered a serious loss by the depredations of thieves, who recently broke into the dome room in the night time, unscrewed and carried off the object glass of the great equatorial telescope. This lens was the most desirable piece of property in the establishment, its value being \$4,000. Nothing else was stolen; it is therefore evident that the robbers knew what they were about. This lens was one of rare excellence, thirteen inches in diameter, and the third largest, we believe, in the United States. It was made by the late Henry Fitz of this city. The loss of the lens is keenly felt by Professor Langley as it of course renders the telescope useless. It is probable that the robber will hold the precious glass in concealment, hoping for the offer of a handsome reward for its return. This is the only way in which the thief can hope to realize from it any considerable amount. On page 34 of our last volume will be found a large engraving of the splendid instrument from which this lens was stolen, with the various appurtenances, such as spectroscopes, micrometers, eye pieces, galvanometers, operating mechanism, etc.

The interior of the observatory appears to have been well supplied with electrical instruments; but unfortunately the simple burglar alarm was not included. This singular rob-

bery will, we trust, be of useful effect to the managers of other institutions where valuable instruments are employed, by inducing them to place electric alarm wires in connection with the doors and windows. We presume this will be done at the Allegheny Observatory now that the lens is gone.

THE NEWARK INDUSTRIAL EXPOSITION.

The first Exposition of Newark manufactures, which for the past two weeks has been in progress in that city, is not only creditable to the enterprise of the gentlemen through whose exertions it was called into existence, but it is especially noteworthy from the fact of its being the first exhibition of the purely local industries of any particular city or town that has taken place in this country.

It is perhaps hardly fair to draw conclusions, as to what the exhibition will be towards its close, from its incomplete condition at present. Several parties who doubted the final success of the undertaking have been tardy in sending in their goods, so that many vexatious delays have been necessitated in the different departments.

The building in which the fair is held is the Skating Rink of the city, to which additions have been made, so that the entire edifice now covers an area of some 50,000 square feet. On entering, the visitor is confronted by a handsome fountain, profusely surrounded with exotics and tropical plants, arranged in excellent taste. On either side of the door a fig and lemon tree in full bearing produce, by their thick foliage, a pleasing and unique effect. In the middle of the hall a large Matthews soda water fountain of white marble (and not a Newark manufacture, by the way) serves as a central ornament. From the arched roof, a number of flags hanging from transverse ropes complete the interior embellishments.

It is, of course, impossible in the space allotted to mention all the exhibitors whose manufactures are to be found on the various tables, so that we are obliged to omit reference to many whose goods doubtless deserve extended notice. In the Rink proper, Mr. A. F. Conery exhibits a finely arranged selection of brushes of various kinds. Those for painting purposes are constructed on an improved method, whereby the handles are freed from the common defect of shrinking. Harness, hardware, and fittings occupy several cases and tables, making a dazzling display of gold and silver ornamentation. The Hedenberg Works contribute a case of tools of different descriptions and an assortment of "Diamond" saws. The Newark Tea Tray Company fill a large compartment with their products. This corporation manufactures an immense number of japanned tin and iron articles, and supplies not only a local but a large foreign trade. By a peculiar process, the Japan is so attached to the metal that it is prevented from peeling or cracking off, no matter how severe the usage to which the article is put. The cutlery establishments of R. Heinisch, Furness, Bannister & Co., and others, exhibit several cases of elaborately made knives, shears, etc. Durand & Co., manufacturing jewelers, contribute a magnificent show of jewelry valued at a fabulous sum. In the center of the case, surrounded by ornaments of every description, is a circular box of some two or three inches in diameter filled with superb diamonds, which produce a dazzling effect.

There are the usual articles which somehow creep into every fair, made after much labor with the most inappropriate tools. This time they are a baby carriage and card table, constructed of over a thousand bits of wood by some patient individual, aided solely by a shoe knife. We have but one comment to make on such work, and that is that it only evidences a great amount of time and labor totally wasted, which might have been applied to useful and productive results.

In the rear of the apartment are some handsome pieces of furniture by local makers, and a design in plaster, finely conceived and executed, for a Firemen's Monument, by E. J. Kising. We shall look with some interest for further products of this artist. Charles Cooper & Co. exhibit specimens of chemicals manufactured at their factory, and the Passaic Carbon Works present samples of ground bone and other artificial fertilizers. To the left of the main building is a large room containing carriages of different patterns and some excellent specimens of beveled, bent, and cut glass. This department is not complete at present.

The machinery department on the opposite side of the Rink will doubtless be better filled when the Exposition has been longer in progress. At the present time, we notice three of the well known Baxter engines and a large horizontal forty horse power engine, made by Watts, Campbell & Co., which is to furnish motive power to other machinery. A Bailey & Burnet steam pump is at work raising water from a small tank for about three feet and then sending it back again, thereby making considerable show, but proving absolutely nothing as to its merits. Other machines lie scattered around in picturesque disorder, on which we make no comment as, besides being already familiar to our readers, they are not in proper condition to pass judgment upon. A few specimens of artificial stone are exhibited from the works of Thomas Gay & Son. The Oraton Paint Works contribute samples of zinc and lead paint, and Blanchard Brothers & Lamb, John Young, and other firms, several cases of patent and enameled leather, cloth, etc.

In the art department, above the main Rink, a collection of paintings is on exhibition. A few pleasing works, occupying by no means the most prominent places, brighten up the display which is otherwise below mediocrity. In architectural drawings, we notice especially some excellent designs for the proposed Roman Catholic cathedral in Newark, and also plans of inexpensive country residences, which display considerable taste. The photographs are ordinarily good.

Altogether the Exposition, for the inception of which credit is due to Mr. Holbrook, its present Secretary, and Mr.

Tombs, of the Newark *Evening Courier*, has set a worthy example, which deserves to be followed by other manufacturing communities.

[Special Correspondence of the Scientific American.]

LETTER FROM PROFESSOR R. H. THURSTON.

The great iron mines of Michigan.—Magnetic and hematite ores.—Their characteristics and values.—Evidences of ancient earthquakes.—Method of mining and shipping the ores.—Climate, scenery, and attractions of Marquette.

NEGAUNEE, Mich., July 24, 1872.

From Marquette, the Peninsular railroad runs its trains to Escanaba, on Green Bay, and the Marquette and Outonagon railroad runs through all the towns of the iron range, as far as now opened, to Champion, a distance of about thirty miles. This latter road will probably be extended as new mines are opened, and will finally connect the iron with the copper regions, terminating at L'Anse or at Outonagon. This is a busy road, its loaded ore trains and empty cars going into Marquette and returning up the road as frequently as time and a single track will permit. As on the Reading railroad of Pennsylvania, the loaded trains are, on this road, almost carried to tide water by their own weight, so uniform and heavy are the down grades. The road is well managed and, I was told, had paid dividends from the beginning. Its repair shops are exceptionally well arranged. The road strikes the iron range at Negaunee, a village about twelve miles south of Marquette, and then follows its course, passing through the several mining towns, nearly to the shore of Lake Michigamme, and is already laid out to new mines to be opened in that beautiful and prospectively wealthy district. I have made Negaunee my headquarters while exploring this part of the country, and have usually been able to make my excursions to the several mines and to return during the same day.

This iron range, although at present only worked along the line of completed railroad, over a distance of about twenty miles, has been explored and found to promise excellent workings throughout a tract of country a hundred miles long and four or five miles in breadth. The Menominee is another range which crosses this, the intersection being at Lake Michigamme, and, although less completely prospected, is known to be equally, if not more, extensive and rich in the best of ores. Copper and lead have also been found in these districts and, at one point, gold has been detected. The whole of this part of the country is, in fact, filled with mineral deposits whose extent and value will probably be not fully determined for many years, notwithstanding the fact that capital is now rapidly supplying the means for exploration and development. The ores of iron are generally found in hills like the Iron Mountain of Missouri, and, in some places, all of the visible rocks and pebbles are composed of pure rich iron ores; and stripping off a few feet of earth or a thin layer of quartzite reveals ore deposits everywhere along the range. The extent and richness as well as, in places, the variety of these deposits are wonderful.

MAGNETIC AND HEMATITE ORES.

The ores vary in character in different districts, and sometimes in different parts of the same district. At one point, the beautiful crystalline magnetic black oxide, somewhat resembling the Lake Champlain ores, is obtained, of which seven tenths is metallic iron. At another point, in the same mine not unfrequently, the ore is heavy, black, brilliantly glistening and equally rich; this is the specular red hematite, called red hematite because, when rubbed, its mark is bright red. Other mines yield a crumbling brown earthy material which one, who had only known the other forms, would hardly suppose to be an iron ore; this is brown hematite, yielding a brown streak when scratched. Some of these soft hematites contain manganese, a most valuable constituent where the ore is intended to be reduced for Bessemer metal. Others contain quantities of lime, an essential material in the blast furnace, where it forms a glass or "slag" with the silica and other impurities of the ore and carries them away, leaving the melted metal, purified, in the hearth of the furnace. I doubt if, in any other part of the world, there can be found such extent and variety of valuable ore deposits.

The ores exported from the district are principally of the richer varieties, and the shipping standard is intended to be 66 per cent of metallic iron.

EVIDENCES OF ANCIENT EARTHQUAKES.

The ores sometimes lie in tolerably regular beds, but more frequently in very irregular masses. The impression acquired by examining the Jackson mine particularly is that, in some geological period of long ago, this part of the country was agitated by a terrible earthquake, and that, among the cracks and ragged chasms of the disrupted and shattered rocks, these vast deposits were gradually precipitated from an aqueous solution by some, as yet unknown, chemical process. In attempting to secure for me a fine specimen of ore at the Grand Central mine, a mass was broken by the blow of the miner's "pick," and, from a cavity in its center, flowed a quantity of water which had probably been imprisoned ages ago when the ore first arranged itself in minute crystals to form the chamber. At another place, a water worn quartz pebble was found enclosed in the mass of dense hematite or specular ore in which the mine was worked. These are both interesting evidences of the aqueous origin of these ores. The former specimen is preserved, with many others from the mineral districts visited, in the cabinets of the Stevens Institute of Technology.

These great deposits of iron ore have been known from a very early period, but it was not until 1846 that the first mine

was opened—the Jackson, here at Negaunee. Now there are about twenty-five mines sending off ore from this Marquette range alone. In 1856, 5,000 tons were exported annually; this year the exports will reach 800,000 tons, and the quantity mined will nearly reach 1,000,000 tons.

METHOD OF MINING.

The method adopted in mining is usually that of open working, already described as in operation at the Iron Mountain of Missouri, precisely that adopted in every stone quarry. In one or two mines, the character of the deposit has induced the proprietors to proceed in the regular system of underground working of all deep mines, that which has been described in the preceding letter from the copper district. At the Jackson mine, nearly all of the ore, which is a specular hematite, is won by quarrying; at the mines at the other, the western, end of the line, a considerable amount of ore is obtained, from deposits of mixed magnetic and specular ore extending far down into the rock, by "candle light work." The ores are shipped principally from Marquette, but some cargoes are loaded at Escanaba and a small quantity goes to market by rail. The loading docks at Marquette are well designed and exceedingly convenient. The cars run upon them, drop their loads into "pockets," which, in the principal dock of the railroad company, can, altogether, receive 10,000 tons, and can be discharged in a single day, should a sufficient number of vessels be obtained to receive so much. The amount shipped per day at Marquette is, just now, about 3,500 tons.

From the shipping ports, it is taken to the principal lower lake ports and is thence distributed to all parts of the country between the Alleghenies and the Mississippi and between the lakes and the Ohio.

CLIMATE AND FEATURES OF MARQUETTE.

This part of the country is just now frequently visited by tourists, who explore the mines, fish in the beautiful clear streams that abound here or in the lakes, and enjoy themselves in innumerable ways. Marquette will probably soon become a famous watering place, and it has already a large number of annual visitors. The climate here is delightful at this season, and, sitting by the fire in the evening or walking out, comfortably wrapped in shawls or overcoats, we can hardly realize that, in New York, you are suffering with heat and that each day has a record of deaths from sunstroke. The climate of this region must be a healthy one at all seasons, I should suppose, for a stronger looking people and healthier appearing children are not to be found anywhere, even though they do, occasionally, find the mercury frozen in the bulb of the thermometer during their long cold winter.

It was with great reluctance that I compelled myself to refuse the many invitations extended to visit parts of the country which I had not found time to explore, and to defer to some subsequent occasion further examination of this wonderfully interesting and most important section of the north-west. I hope and anticipate that circumstances may, at some time, permit another and a longer visit. R. H. T.

Kemmer's Patent System of Fresco Painting.

In our issue of June 22d we alluded to the new system of oil fresco painting, invented and recently patented by Mr. Charles T. Kemmer, of Newark, N. J. At that time we had not seen any of his decorations upon the wall, but, from the description in his patent and the inventor's explanation of the process, we predicted that it was likely to supersede the ordinary mode of frescoing. We have since had an opportunity of seeing the ceilings and walls of a large hall in the process of decoration, and have examined them since the completion; and our good opinion of the invention, as previously expressed, is more than confirmed.

The work done has all the appearance of, and in fact is, elaborate frescoing in oil, and yet is not only more durable but less expensive, equally artistic, and far more readily accomplished. A reference to our issue of the date above referred to will inform our readers of the peculiar manner in which these decorations are prepared, although the method may be briefly stated to be the formation, on a prepared sheet of muslin, of a thick film of paint which is easily removed and readily cemented to the plaster of a ceiling or wall.

As this invention has been proved to be so eminently successful, it carries with it advantages which make it greatly superior to the ordinary method of fresco painting. The use of scaffolding, expensive and cumbersome, in one's apartments for weeks at a stretch is avoided. The decorations can be designed according to order, executed in the shop, brought to the house, and put in place; and instead of the whole building being in confusion for weeks at a time, three or four days will suffice to complete the job. Moreover, better work can be done; the artist is not obliged to labor lying on his back or twisting his head into awkward and painful positions—often in the worst of lights.

Interior decoration is carried on principally during the summer months. Necessarily work is plentiful, skilled workmen are difficult to obtain, and expenses are proportionately great. Using the Kemmer process, the labor can be done during the cold weather, when the best of artists are out of employment and can be had at low wages.

The film above alluded to is composed of six coats of the best oil fresco paint, and the gilding is pure gold leaf. Consequently a wall or ceiling may be washed like ordinary paint with soap and water, a proceeding which is impossible with common fresco work. The film, though thin, is elastic and does not crack with the wall, unless very large openings appear, which are generally few and susceptible of easy repair. The most elaborate designs can be prepared for any sized apartments,

We speak thus approvingly of the process of Mr. Kemmer because we believe it to be the best yet invented. The proprietors of the St. Nicholas Hotel in this city have had a parlor decorated after this plan, and other hotels are about to try it. It is stated that a manufactory on a large scale, devoted to this invention, is contemplated. If so, it will inaugurate an entirely new industry and one well worthy of the attention of capitalists and business men. Charles T. Kemmer & Co., office at 4 Warren street, New York city, or at Bower's boat house, East Newark, N. J. may be addressed for any further information.

The Kitchen Range.

If Satan himself, says the New York Express, had put his wits to work this hot weather to give city mankind a foretaste of his infernal regions, he could not have constructed a machine more diabolical than the kitchen range, filled with red hot anthracite coal, in a block of city houses, to roast city therewith. Think of it! you have not only one red hot kitchen range to roast you, but two, on each side of your house, one from your neighbor's kitchen on the right, and the other from the other neighbor's kitchen on the left! There are thus three fires to open their blazes upon you, when the thermometer is near the hundred—and while the salamander cook can stand it, the dwellers above and the sleepers in the chambers, where the fiery flues go, feverishly flit about by day, and groan in heated agony all night.

Cannot some American genius supplant Satan in this diabolical invention for cooking? In other climates, where, bless fortune, there is no anthracite coal, and where wood, weighed by the pound, costs something, all the cooking is done—and as well done as we do it, if not better—with a fiftieth part of the fuel we use; and so in the cooler climates of Europe, where charcoal is used or bituminous coal, which is not "red hot" like the anthracite. Are Americans only born to be roasted in summer fires of the kitchen? Is it the glorious privilege of our country to use fifty pounds of fuel to cook with when other nations use but one? Wake up, Yankee inventor, and invent or discover for us something to save us poor summer city from being carbonized these hot days, or from melting away into grease! The kitchen range will do, as conducted in winter, when the thermometer is down to zero, but never, never in such summer weather as we have been having for twenty days past.

Genius solved this problem long ago by the invention of the gas stove. For summer use, in cities, nothing can be more convenient or economical. Placed upon the kitchen table, you can broil your steak or chicken in the most admirable manner, boil your coffee, roast your potatoes, bake your biscuits, fry your cakes and heat your flat irons. The range fire with its overpowering heat is rendered quite unnecessary. People who make complaints ought to look a trifle beyond their noses before they cry out. People who make the loudest complaints are apt to be those who have not looked beyond their noses.

Business and Personal.

The Charge for Insertion under this head is One Dollar a Line. If the Notices exceed Four Lines, One Dollar and a Half per Line will be charged.

The paper that meets the eye of manufacturers throughout the United States—Boston Bulletin, \$4 00 a year. Advertisements 17c. a line.

Wanted—The New York Steam Engine Co., Manufacturers of Machinists' and Railway Tools, can give steady employment to a number of good machinists used to tool work. At their Shop in Passaic, N. J., 11 miles from New York, on Erie Railway.

Large lot of Machinery for Sale. See adv. of Geo. Place & Co.

Engine for plowing—I have a traveling engine for plowing and all other draft and stationary purpose. Has a new device for overcoming hills. Will draw six times its own weight. Light, cheap, durable, and effective. Will be on exhibition in Oct. at Kalamazoo, Mich. D. C. Pierce.

Rust's Boiler Plate Hand Punches. S. C. Hills, 32 Courtlandt st.

Circular Saw Arbors, all styles and sizes. Wm. Scott, Binghamton, N. Y.

For Patent Vertical Portable Engines and Saw Mills, with all late improvements, apply to Griffith and Wedge, Zanesville, Ohio.

A first class Machinist and Tool maker, fair Draughtsman, wishes a situation. Address Tool Maker, Plainville, Conn.

A Chance for a Big Speculation!—A valuable Patent, and Machinery, Stock, &c., which cost over \$3,000, can be bought very cheap as the parties are out of funds. Address P. O. Box 204, Bellefonte, Pa.

Engine and Speed Lathes of superior quality, with hardened Steel bearings, just finished at the Washburn Shop, connected with the Free Institute, Worcester, Mass.

Brick and Mortar Elevator and Distributor—Patent for Sale. See description in SCI. AMERICAN, July 20, 1872. T. Shanks, Lombard and Sharp Streets, Baltimore, Md.

The Berryman Manf. Co. make a specialty of the economical feeding and safety in working Steam Boilers. Address I. B. Davis & Co. Hartford, Conn.

The Berryman Heater and Regulator for Steam Boilers—No. one using Steam Boilers can afford to be without them. I. B. Davis & Co., Hartford, Conn.

Brown's Coal Yard Quarry & Contractors' Apparatus for hoisting and conveying material by iron cable. W. D. Andrews & Bro., 414 Water st., N. Y.

For Machinists' Tools and Supplies of every description, address Kelly, Howell & Ludwig, 917 Market Street, Philadelphia, Pa.

Williamson's Road Steamer and Steam Plow, with Rubber Tires. Address D. D. Williamson, 32 Broadway, N. Y., or Box 1809.

Belting as is Belting—Best Philadelphia Oak Tanned. C. W. Arny, 301 and 303 Cherry Street, Philadelphia, Pa.

To Ascertain where there will be a demand for new Machinery, mechanics, or manufacturers' supplies see Manufacturing News of United States in Boston Commercial Bulletin. Terms 4.00 year.

Large lot of Machinery for Sale. See adv. of Geo. Place & Co. Microscope—Zeutmayer wanted. Address H. F., Box 608, Baltimore, Md.

Stove Pattern Makers, please send address to Thomas Rossre, Bellaire, Ohio.

Meat Chopper—The Union Meat Chopper—the Best in the country. For Circulars and Price Lists, address J. Dyer, Elizabethtown, Pa. For the best Gauge Lathe, address T. R. Bailey & Vail, Lockport, N. Y.

Models and Patterns of all kinds made in the best manner at lowest prices. Geo. B. Kilbon, 35 Market St., Springfield, Mass.

Who fits up and furnishes the tools, machinery, and fixtures for factories of shoe lasts, especially polishing and grinding machines? Offers, with illustrated catalogues and prices, to be addressed to T. V., 786, care of Messrs. Haasenstein & Vogler, Stuttgart, Germany.

A practical Circular Sawyer wants a Situation in the United States after January 1, 1873. Address Yankee Sawyer, Arthabaska Station, Province of Quebec, C. E.

Wanted—Engagement as Manager in a Machine Works by a thorough Practical Engineer and Draughtsman: large experience home and abroad, designing and constructing Special tools, Steam and general Machinery. Address "Machinist," care A. D. Haight, 239 Broadway, N. Y.

Knitting Machinery—Wanted to superintend the practical working of Improved Knitting Machines—23 years' experience: England, France and Germany. "Self-acting," Windsor Locks, Conn.

Flouring Mill near St. Louis, Mo., for Sale. See back page.

Steel Castings to pattern, strong and tough. Can be forged and tempered. Address Collins & Co., 212 Water St., New York.

Wanted—A live man, acquainted with Turbine Wheels, to travel. Address Urbana Machine Works, Urbana, Ohio.

It is better to purchase one of the American Twist Drill Company's Celebrated Patent Emery Grinders than to wish you had.

Walrus Leather for Polishing Steel, Brass, and Plated Ware. Greene, Tweed & Co., 18 Park Place, New York.

Ashcroft's Original Steam Gauge, best and cheapest in the market. Address E. H. Ashcroft, Sudbury St., Boston, Mass.

Steam Boiler and Pipe Covering—Economy, Safety, and Durability. Saves from ten to twenty per cent. Chalmers Spence Company foot East 9th Street, New York—1202 N. 2d Street, St. Louis.

Ashcroft's Self-Testing Steam Gauge can be tested without removing it from its position.

Brown's Pipe Tongs—Manufactured exclusively by Ashcroft, Sudbury St., Boston, Mass.

Dickinson's Patent Shaped Diamond Carbon Points and Adjustable Holder for dressing emery wheels, grindstones, etc. See Scientific American, July 24 and Nov. 20 1869. 64 Nassau st., New York.

Page's patent Belt Lacing, as made by J. H. & N. A. Williams, Utica, N. Y., is the best and cheapest.

American Boiler Powder Co., Box 797, Pittsburgh, Pa., make the only safe, sure, and cheap remedy for 'Scaly Boilers.' Orders solicited.

Machinery Paint, all shades. Will dry with a fine gloss as soon as put on. \$1 to \$1.50 per gal. New York City Oil Company, Sole Agents, 116 Maiden Lane.

Whitcher's Pat. Rotary Engine is the simplest, cheapest, and most economical. On exhibition at P. Fields & Son, North Point Foundry and Machine Works, Jersey City, N. J.

Windmills: Get the best. A. P. Brown & Co., 61 Park Place, N. Y.

Boynnton's Lightning Saws. The genuine \$500 challenge. Will cut five times as fast as an ax. A 6 foot cross cut and buck saw, \$6. E. M. Boynnton, 80 Beekman Street, New York, Sole Proprietor.

Better than the Best—Davis' Patent Recording Steam Gauge Simple and Cheap. New York Steam Gauge Co., 46 Cortlandt St., N. Y.

For Solid Wrought-iron Beams, etc., see advertisement. Address Union Iron Mills, Pittsburgh, Pa., for lithograph, etc.

For hand fire engines, address Rumsey & Co., Saueca Falls, N. Y.

All kinds of Presses and Dies. Bliss & Williams, successors to Mays & Bliss, 118 to 122 Plymouth St., Brooklyn. Send for Catalogue.

Mining, Wrecking, Pumping, Drainage, or Irrigating Machinery, for sale or rent. See advertisement, Andrew's Patent, inside page.

For Hydraulic Jacks and Presses, New or Second Hand, send for circular to E. Lyon, 470 Grand Street, New York.

For Marble Floor Tile, address G. Barney, Swanton, Vt.

Old Furniture Factory for Sale. A. B., care Jones Scale Works, Binghamton, N. Y.

Portable Baths. Address Portable Bath Co., Sag Harbor, N. Y.

For Steam Fire Engines, address R. J. Gould, Newark, N. J.

Peck's Patent Drop Press. For circulars address the sole manufacturers, Milo, Peck & Co., New Haven, Ct.

Presses, Dies & all can tools. Ferracute Mch Wks, Bridgeton, N. J. Also 2-Spindle axial Drills, for Castors, Screw and Trunk Pulleys, &c.

New Pat. Perforated Metallic Graining Tools, do first class work, in less than half the usual time and makes every man a first class Grainer. Address J. J. Callow, Cleveland, Ohio.

Declined.

Communications upon the following subjects have been received and examined by the Editor, but their publication is respectfully declined:

- BOILER EXPLOSIONS.—T. K.
- BURNING BRICKS.—J. D.
- CARBONIC ACID GAS.—L. G. F.
- EXPLOSION AND BURSTING OF STEAM BOILERS.—A. F. W. N.
- LAWS OF ELECTRICITY.
- MECHANICAL FORCES.—J. W.
- MECHANICAL POWER.—H. H.
- MINERAL SPRING.—J. C.
- PRODUCERS AND CONSUMERS.—J. E. S.
- PROPORTIONS OF ENGINES.—H. A. B.
- SPECTRUM ANALYSIS.—W. A. M.
- TIME.—A. M. T., Jr.
- WATER FROM THE DEPTHS OF THE SEA.—M. D. M.
- * YOUNG MACHINIST.—F. B. C.—S.
- NOTES AND QUERIES.—J. M. E.
- ANSWERS TO CORRESPONDENTS.—W. H. P.—M. R.—E. J.—H. H. L.—A. H. G.

Facts for the Ladies.—Mrs. M. C. Wheeler, Wolcottville, Ct., has used a Wheeler & Wilson Lock-Stitch Machine constantly, since 1858 in family sewing, with no expense for repairs and only two needles broken. See the new Improvements and Woods' Lock-Stitch Ripper.

Notes & Queries.

[We present herewith a series of inquiries embracing a variety of topics of greater or less general interest. The questions are simple, it is true, but we prefer to elicit practical answers from our readers.]

1.—**CHLOROFORM.**—Can any one give a simple method of making chloroform?—C. T. B.

2.—**SHADE TREES.**—What is the best time of year for topping oak and hickory trees to make a shade?—T. C. J.

3.—**ACTION OF MILK ON INK STAINS.**—"To remove from clothing stains of common writing ink, dip the fabric in sweet milk, and it will wash white at next washing." Will some one give the chemistry of this?—P.

4.—**KOUMISS.**—Will any of your readers give a formula for making, or any information respecting, koumiss, or where it may be obtained?—W. R. J.

5.—**BURNING CHARCOAL.**—What is the best mode of burning charcoal on a small scale, say six or eight bushels at a time? I would prefer to use a cone of sheet iron instead of the old plan. How must I construct the cone, and how must I proceed to get charcoal?—C. G.

6.—**ADHESIVE CEMENTS.**—What is the best paste and preparation of the same for pasting prints on muslin, as is done in map mounting? What would be the strongest gum for fastening muslin upon wood? It should be colorless and as nearly insoluble in water as possible.—A. B.

7.—**MULTIPLYING GEAR FOR PROPELLER.**—How are the quick revolutions of the screw of a propeller, produced, as used in the propulsion of vessels in New York harbor? Is it done by cog gearing, or how?—T. and W. M.

8.—**PORTABLE FURNACE FOR MELTING IRON.**—How can I construct a small portable furnace, suitable for melting small quantities of metal at a time, that will produce sufficient heat to melt iron?—D. M.

9.—**RUST JOINTS.**—How can conical lathe centers, that have become fastened in their sockets by rust, be got out?—D. M.

10.—**WEIGHT OF WATER.**—How much pressure will there be on each square inch of the bottom of a hoghead if there are three feet of water in the hoghead, when the air over the water is exhausted from the hoghead? In other words, how much pressure will the weight of the water make on each square inch, taking the atmospheric pressure off from the top of the water?—J. J. T.

11.—**CHURNING BUTTER.**—Why does cream produced from milk of the same cow, and churned at the same temperature, require two and oftentimes more hours at some churnings, and but fifteen minutes at others, before the butter has become sufficiently collected or compact to be removed? The butter is visible in small particles after a few minutes churning, and so remains for the time specified.—A. T. M.

12.—**RELATIVE HEIGHTS OF THE ATLANTIC AND PACIFIC OCEANS.**—Can any of your correspondents inform me which ocean is the highest at the isthmus, the Atlantic or the Pacific? What is the difference? Has there recently been a survey for a ship canal between the two oceans?—J. P. W.

13.—**INDELIBLE PRINTING INK.**—Can any of your readers give a recipe for making a printers' ink that is indelible?—W. C. D.

14.—**TRANSFERRING CHROMOS TO GLASS.**—I have seen in England windows beautifully adorned with chromos and other pictures transferred to the glass, so well done that the effect is like that of painted glass. In my dining room is a large bay window, the lower half of which I want to embellish in this way, chiefly for the purpose of masking a fence. How can the pictures be transferred to the glass so as to make a good job of it?—N. D.

15.—**THE "JAWSHARP."**—Why does the jawsharp (not Jewsharp) give all the notes of the scale, having but one note when held in the hand? Is the vibration of the tongue governed by all of the vocal organs?—B.

16.—**DIMENSIONS OF BOILER.**—Please inform me what are the proper dimensions of a horizontal boiler with two flues in it, for running a small horizontal stationary steam engine, with a four inch stroke, with a cylinder of one half inch diameter, the drive wheel weighing about thirty pounds? It is used in running a foot lathe.—A. F. B.

17.—**PHOSPHORESCENT OIL.**—I have tried the phosphorescent light described on page 10 of your current volume. I prepared it with phosphorus and olive oil, but I only get a faint light on removing the cork, not sufficient to be of any service. What is the trouble? I followed D. B.'s directions in preparing it. Can any correspondent give me some light as to where the fault is?—A. H. S.

18.—**CEMENTING COLD STEEL AND MELTED IRON.**—Is there any preparation that can be applied to cold steel so that, when melted cast iron comes in contact, they will unite?—A. W. B.

19.—**DIURNAL MAGNETIC VARIATION.**—Is there any diurnal variation of the needle on the line of no variation? Here the diurnal variation is from 10' to 15', according to temperature, and is greatest about 2 or 3 P. M., the variation being west. Where the variation is east, is it greater or less in the after part of the day?—T. H.

Answers to Correspondents.

SPECIAL NOTE.—This column is designed for the general interest and instruction of our readers, not for gratuitous replies to questions of a purely business or personal nature. We will publish such inquiries however, when paid for as advertisements at \$1.00 a line, under the head of "Business and Personal."

ALL reference to back numbers must be by volume and page.

DISTANCE OF LIGHTNING STROKE.—H. H. L. Jr., is informed that the error he alludes to is caused by the misplacement of the decimal point. The correct reading is obvious to everybody.

WOODEN RAILWAYS.—We are again asked for further information on this subject. We shall be glad to hear from Mr. J. B. Hulbert on the subject.

THE ANCIENT EGYPTIANS.—T. C. J., of Tenn., is informed that the Caucasian origin of this people has long been an ascertained fact. Their language had an affinity to the Hebrew and Arabic tongues, and craniology points out a wide difference between them and the Africans. Herodotus certainly speaks of them as being black and woolly haired; but it is more than probable that, previous to his day, they had largely intermingled with the native races of Africa. That the statements of the Greek historian are not correct as to the Egyptians in early times, the thousands of mummies in existence at this day furnish abundant testimony.

PERPETUAL MOTION.—C. A. N., of Tenn., is informed that a machine run by magnetic attraction cannot be called a perpetual motion. Gravity cannot impart perpetual motion, for, as soon as the weight reaches the center of attraction, the force ceases; and as soon as the armature touches the magnet, the motion is at an end. We are not aware that any reward for the discovery of perpetual motion was ever offered by either the United States or British government. The impossibility of arriving at the result has long been demonstrated; and probably no government would encourage the ignorant to waste their time on a chimera.

WATERPROOFING COTTON CLOTH.—F. C. is informed that we have recently published many recipes for this, and have referred many of our correspondents to them. See Answers to Correspondents, page 10 of our current volume.

METAL LINING IN CAST IRON BOXES.—What metal does W. A. use, that his linings get in six weeks a play of a sixteenth of an inch? Is it Babbitt metal, minus the antimony, mentioned by him in his original query? The defect is probably in the metal. If it be hard enough, the plan illustrated by us on page 90, current volume, will hold the lining till it is all worn away.

PROTECTING BRICK WALLS.—Is it practicable to use silicate of soda (liquid glass) for painting or coating a brick wall, and then to render it insoluble by the application of chloride of calcium or any other chemical? I am informed that the idea was suggested in Muspratt's "Chemistry." It has been objected that the salts would appear on the surface as an efflorescence, and thus disfigure the building. Can any one tell me as to this, and is there any other objection? I believe it would form the best possible protection for brick walls, especially against moisture, which is our great trouble in this latitude.—I. Answer: Muspratt's proposition is to use the silicate of soda to preserve the oolitic and dolomitic limestones, which are continually being disintegrated by the sulphurous acid in the atmosphere of cities. Well burnt brick is not subject to this influence, and is, as we see in Egypt and Palestine, the least perishable of all human productions.

A. H. M. & Co., Ala.—The mineral you send is talcose slate, and like steatite, to which it is related, it is infusible. When sufficiently compact, it may be worked into fire stoves; one variety is used for hones and scythe stones.

CLOCKWORK TO RAISE WATER.—B. Smith is referred to by the editor of the *Rural New Yorker* for a reply to the following enquiry: Would a machine constructed on the order of clockwork, and run by a weight, raise 100 gallons of water, in twenty-four hours, from a well 25 feet deep, to a point 10 feet above the ground, said machine to run for 24 hours without being wound up more than once? If so, what would be the arrangement of the wheels to do the required work? Answer: Yes, a clockwork machine, driven by a weight, to be wound once in 24 hours, might easily be made to do the above work. The arrangement of gearing would be similar to the churn drivers, now in common use, which consist of four cog wheels, rope, and weight. 100 gallons of water weigh 833 pounds. The work to be done is therefore to lift 833 pounds of water 35 feet high in 24 hours. A man could do that work with a pump or buckets in ten minutes; and would be occupied about the same length of time in winding the machine we have described.

MILLING COINS.—To C. A., query 4, page 122.—The milling is done by engraving one of the dies in a cavity in the steel, the cavity being of the depth of the thickness of the coin, and having its edges milled. The pressure of the coining press forces the metal into the milled rim of the die.—D. B., of N. Y.

THE EARTH'S ORBIT.—O. F., query 6, page 106, is informed that, owing to the elliptical form of the earth's orbit, that the distance between the earth and the sun is greatest in January and least in July.—D. B., of N. Y.

POWER OF ENGINE.—Query 13, page 153.—W. H. P.'s engine shows by the usual formula a power of between 9 and 10 horses. But the percentage of friction is usually large in cylinders of such small dimensions, and the application of an indicator would probably show a considerable discrepancy between the pressure in the cylinder and that of the boiler.—D. B., of N. Y.

SPECIFIC GRAVITY.—J. P., query 15, page 153, is informed that there is a greater attraction, that is, a body will weigh more, at the poles than at the equator. This is owing to the flatness of the earth at the poles, and the attraction, according to the law discovered by Newton, varies inversely as the square of the distance.—D. B., of N. Y.

IRON RUST STAINS.—To R., query 1, page 122.—Soak the stained parts in a mixture of sulphuric acid one part, and water two parts, having the mixture pretty hot; then thoroughly wash in clean water.—E. H. H., of Mass.

ROOT BEER.—To G. W. E., query 3, page 122.—You may adopt the following plan, but must be careful to use an ordinary soda water copper fountain or other vessel to stand the pressure of the gas. To the beer add one ounce and a quarter of bicarbonate of soda and one ounce of tartaric acid to each gallon. The tartaric acid will combine with the soda, and form tartrate of soda, and liberate carbonic acid gas; this, being confined in the vessel, will exert so much pressure as to easily force the effervescent beer up the pipe into the fountain. The tartrate of soda is perfectly harmless, but has a slight aperient property. Each soda fountain usually holds ten gallons, so you will add 1½ ounces of soda and 10 ounces of crystal or powder acid.—E. H. H., of Mass.

WHITE VINEGAR.—To L. C. M., query 7, page 112.—Cider vinegar may be decolorized by digesting with and filtering through fresh burned animal charcoal, as used by sugar refiners. Cider vinegar, however, will not answer for pickling large fleshy cucumbers, tomatoes, etc., but may do well enough for small radish pods, gherkins, small pepper pods, etc. The reason is this: Large cucumbers, etc., already contain a large quantity of juice or water; if you add a comparatively weak vinegar, this juice will still further reduce the strength below the point necessary to preserve from putrefaction. Large and juicy fruit with strong acid, and small dry fruit with weaker acid will do.—E. H. H., of Mass.

SPONTANEOUS IGNITION.—To G. T. R., query 9, page 122.—Make a stiff paste, with water, of equal parts of powdered white sugar and chlorate of potash; dip the ends of match sticks until thickly coated, and dry. Have a small bottle half full of sand, saturated with sulphuric acid. On dipping a prepared match into the acid, you will have a spontaneous flame. Use a little care in trying this.—E. H. H., of Mass.

LINSEED OIL FOR WATERPROOFING.—To B. B. B., query 10, page 122.—Boil pure linseed oil in an iron pot over the fire for four or five hours, or until it has become thick and viscid; towards the close of the operation, set the flames of the oil on fire for five minutes or so, and put out the flames by putting sheet iron or a board over the vessel, and so excluding the air. Have the vessel abundantly large, and if it accidentally inflames, and you want to extinguish it, on no account use a drop of water, but rather throw over the vessel a wetted thick blanket or piece of carpet, or adopt the iron or board plan. Be prepared beforehand for the emergency. When boiled to the proper consistency, spread while hot on to your fabric, or, if more convenient, allow to cool and dissolve in benzine to a suitable attenuation, and apply in successive coats till thick enough. Mix lamp or ivory black to give your color. You will find this varnish act perfectly for your boat, and the benzine dries very rapidly.—E. H. H., of Mass.

DIAMONDS.—To C. W. P., query 1, page 138.—You will find on experiment that fluoric acid will corrode any of the precious stones except diamonds. The value of a diamond is estimated by its color and density.—H. M. B. of W. Va.

Recent American and Foreign Patents.

Under this heading we shall publish weekly notes of some of the more prominent home and foreign patents.

HEATING STOVE.—Thomas Scantlin, of Evansville, Ind.—This invention has for its object to furnish an improved heating stove so constructed and arranged as to utilize the most of the heat contained in the smoke and other products of combustion before allowing them to escape into the chimney and so as to enable a direct draft to be conveniently obtained when desired.

SAFETY VALVE.—Michael Smart and Thomas W. Gaynor, New York city.—This invention has for its object to so arrange a safety valve for steam boilers that it will be sensitive to the action of the steam, and not liable to become obstructed, and it consists in providing the valve chamber with escape steam ports and with a chambered extension, in which is arranged a spiral spring that acts through the medium of a collar and piston rod to partly hold the piston against the pressure of steam in the boiler.

KEY TAG, WATCH KEY, AND KNIFE SHARPENER.—Our engraving represents a combined key tag, watch key, and knife sharpener, which was patented April 2, 1872. Fig. 1 shows the face, and Fig. 2, a side or edge view of the same.

The key is made of gold or other suitable material and is of a convenient shape to have the name, etc., of the owner engraved thereon, while it is provided with a ring for attachment to a bunch of keys. Pivoted to its lower side will be seen the watch key, which is represented in position for use. When not required, it is turned back out of the way until it rests against the small post shown at the upper part of the figures, as indicated by the dotted lines. In this position no dust or other matter can enter the tube of the key. The knife sharpening apparatus consists of the two disks seen in the figures, which lie in a space cut out of the tag, and which are pivoted by rivets to ears left for the purpose, as shown. The edges of the disks are beveled, so that upon drawing a knife across and between them, at right angles, their sharp edges remove a small shaving from each side of the blade. Our engraving is half the actual size of the article, which will no doubt prove a desirable addition to the key bunch without being in any way cumbersome. Propositions for the purchase of the patent will be received by the inventor, John C. Schlarbaum, P. O. B. 245, Virginia City, Nevada.

LIME KILN.—Elisha Randall, of Mason City, Iowa.—This invention consists of a metal hopper at the bottom of the cupola, with an open bottom for discharging and a slide for closing it; also with a revolving grate, with a hand crank above the slide, adapted to pick the pieces of lime apart and facilitate the discharge of it by turning said grate. At a short distance above the hopper, there are two fireplaces on opposite sides of the cupola, arranged and adapted to act quickly on a large surface of the limestone, so as to expedite the burning without overburning any part. And below the hopper is an open archway through the stack and an elevated railway, on which the discharged lime is received in a truck, with a box mounted on journals and designed to be turned bottom side up by gravity for discharging.

HAY STACKING APPARATUS.—Jyrus H. Kirkpatrick, of Sugar Grove, Ind.—This invention has for its object to furnish an improved apparatus for stacking hay, simple, strong, durable, convenient in use and effective in operation, and it consists in the construction and arrangement of the base or platform and post, secured to the platform to the upper end of which is pivoted a crane. To the lower end of the post and to the platform is attached a flanged socket, which is designed to serve as a journal for the driving wheel to which is attached the sweep to which the horse is attached and a leading pole to which the horse's halter is tied.

GAME.—Robert Patterson, of New Santa Fé, Mo.—This invention relates to a new alphabetical game to be used by children to make them fully acquainted with the appearance and the differences of letters and numerals. The invention consists in the use of printed tables containing rows of letters or figures and in the employment of cards or small disks containing similar letters and figures, but singly, so that such disks or cards may be used to cover the places on the printed tables.

EXTENSION SCAFFOLD.—Isaac Noggle, of Butler, Ill.—The object of this invention is to provide suitable and convenient means to enable masons and others to raise themselves to their work; and it consists in an extension framework so constructed as to be used as a scaffold or staging. It is formed of legs or supports, a rail, and bands by which the parts of each are screwed together, so that they may slide and be elongated; and two bands are employed for each leg, one band being attached to one piece and the other to the other piece. The two parts of the rail are confined together in the same manner. The legs are connected together near the top by a screw bolt, and by a link, which latter holds the legs spread at the bottom, so that they will brace the rail laterally. The two legs also form a slot at their top ends to receive the rail, and each part of the rail is recessed on its sides so that the timber will fit into the slots. The recesses in the rail are cut on an incline, so that the legs stand bracing from the center. There is a spring attached to one part of the leg which enters recesses in the other part, which prevents the parts from slipping. The legs may be so adjusted that the rail will stand on a level on uneven ground.

EQUESTRIAN GYMNASIUM.—Eliphalet S. Scripture, of Williamsburg, N. Y.—This invention relates to an apparatus on which imaginary horseback riding, riding in a flying hammock, swinging on a jerking rope, etc. can be enjoyed. The exercises are both amusing and difficult to perform, as they are alternately aided and obstructed by mechanical power. The invention consists in an ingenious arrangement of mechanism for imparting the desired movements to the devices on which the persons taking the exercise are either supported or from which they are suspended.

MACHINE FOR THE MANUFACTURE OF TOBACCO.—Elijah Robinson, Charles F. Robinson, and James E. H. Andrew, Stockport, England.—The invention consists in the combination of three rollers, the surfaces of which are solid or made of segments, to which lateral and from motions are given by cams or other equivalents connected to the stands on which the axes of the rollers rotate. The tobacco to be operated upon occupies the central space between the three rollers, and it is carried through the machine by the lateral and from motions given to the rollers or segments. In manufacturing roll or twist tobacco, the filler and the covering leaves are laid on a table connected to the machine. The filler is placed in the cover, and they pass together between the rollers, the action of which twists and compresses the tobacco into a roll or twist, which is carried forward and wound on a bobbin. The bobbin revolves in an open frame, and the guide is traversed to and fro to distribute the twist of tobacco on the surface of the bobbin.

FENCE.—Isaac N. Lerick, San Antonio, Texas.—In western Texas, where fence timber is extremely scarce and expensive, a resort to iron as a material for fencing is a necessity; and the object of this invention is to so construct an iron fence that in point of cheapness and durability it may be used as a substitute for wood. The post and the brace are made of thin angle iron, and are pivoted together at their top ends. Mortises or orifices are made through the posts for the rails. The rails are made endless and are spliced together by button rivets in one part and button holes in the other. The post and the brace are tied together and held a sufficient distance apart by a bar which is pivoted to the brace and hooked on to a button in the post.

SLOTTING AND SHAPING MACHINE.—William H. Warren, of Worcester, Mass.—This invention has for its object to combine a shaper and slotter in a single machine, mounted upon one frame, and driven by the same driving device, in such a way that they may both work at the same time, or either separately, as desired; and it consists in the two rams, one moving vertically and the other horizontally, and both mounted upon the same traverse shoe and driven by the same driving device. The inventor claims the horizontal and vertical shapings combined with the traverse shoe, feed screw, and lath shear, as and for the purpose described.

[OFFICIAL]

Index of Inventions

for which Letters Patent of the United States were granted

FOR THE WEEK ENDING AUGUST 13, 1872, AND EACH

BEARING THAT DATE.

Table listing inventions and their patent numbers, including items like Acid, manufacture of sulphuric, D. Jackson; Asbestos, yarn, J. S. Rosenthal; Asbestos, treating, J. S. Rosenthal; Augers, hoisting attachment for the shafts of well, H. H. Russell; Baby jumper, J. E. Wells; Bag holder, L. Crofoot; Bag holder, T. J. Trapp; Bale tie, wire, D. McComb; Battery, galvanic, F. E. Beardslee; Beams, machine for shearing the ends of, J. M. Cornell; Bedstead, W. E. Briggs; Bedsteads, crib attachment to, F. Ryder; Bee hive, Longgrear and Clark; Bell hanging, G. R. Meneely; Bench, wash, W. F. Gilbert; Billiard board, portable, L. C. Prindle; Blacking box holder, R. R. Forrest; Bolt, door, Cohen, Penoyer, and Crosby; Boots and shoes, cutter for soles and heels of, S. G. Brown; Braids, trimmings, etc., process of making imitation, H. Loewenberg; Bridge connection, Clark and Bonzano; Broazing machine, L. G. Chaput; Brush, J. Ames, Jr.; Brush holder, blacking, E. H. Sweetser; Brush, box, and holder, combined blacking, E. W. Woodruff; Bustle, S. and D. L. Smith; Calculating machine, E. D. Barbour; Car brake, S. Nunamaker; Car coupling, J. Broadley; Car, dumping, J. M. Goodwin; Carpet fastener, F. O. Clark; Carriage seat, H. Timken; Cartridge loader, pocket, G. F. Dutch; Chair, dentist's, A. W. Morrison; Chalk holder, L. S. Woodbury; Chimneys, flue base for, C. F. Rothe; Churn, N. Hospers; Churn, Christian and Beach; Churn, G. N. Broughton; Churn dasher, R. A. Vick; Cloth bunching machine, J. T. Hennaman; Clothes pounder, M. K. Morris; Cradle, H. H. Wiggers; Cultivator, M. Stoll; Cultivator, L. K. Tipton; Cultivator, C. Marsh; Cultivator, T. Poling; Cylinders, machine for cutting teeth on, Dean, Nicholson, and Ames; Derrick, hydraulic, D. L. Gorman; Dovetailing machine, P. A. B. Triacca; Drag, marine, O. R. Ingersoll; Drilling machine, rock, J. Cody; Drilling machine, rock, D. W. Bricher; Dumping platform, D. A. Wells; Egg carrier, W. Bramwell; Elevator, W. Livingstone; Elevator, hydraulic power, P. J. Borger; Engine, rotary, L. K. Fuller; Engines, cut off valve for steam, C. B. Sheller; Engines, slide valve for steam, H. Elliot; Fabric, knit, H. Boot; Fare box, portable, W. J. Hooper; Fastener, window sash, H. Johnston; Fastener, window sash, C. R. Webb; Fence, H. B. Ramsey; Filter, driving pump, A. J. Sternberg; Finger exerciser, F. Wenzel; Fireplace, M. Haughey; Flour packer, C. Zimmerman; Fluting machine, E. M. Deey; Fork and pick, combined, D. Mater, Jr.; Furnace, cupola and blast, D. W. Hendrickson; Gas apparatus, Porter and Lane; Gas retort, J. C. Tiffany; Gas, manufacture of illuminating, E. D. McCracken; Gas, manufacture of illuminating, St. John and Cartwright; Gas and heating dwellings, apparatus for generating, T. S. C. Lowe; Gas, manufacture of, T. S. C. Lowe; Gas, process and apparatus for making, T. S. C. Lowe; Gin, cotton, E. Osgood; Gin flue cotton, J. W. Gaines; Glass globes, apparatus for roughening the surface of, T. W. Mellor; Governor, W. C. Freeman; Governor valve, W. A. Cogswell; Governor valves, casting for steam, Cogswell and Judson; Grinder, apple, C. F. D. Jones, Jr.; Gun, machine or battery, B. B. Hotchkiss; Hair picking machine, D. M. Varney; Harrow, H. N. Swift; Harvester, J. G. Perry; Beel finishing machines, shave and burnisher for, J. L. Joyce; Hinge, H. Hayward; Hinge, Boileau and Mesnier; Hinge for sewing machine tables, S. C. Brinser; Hinge hooks, manufacture of, W. J. Lewis; Hogs, apparatus for cutting up, W. C. Marshall; Hose carriage, Perrine and Stewart; Hose coupling, Magill and Herbert; Insect destroyer, C. D. Pugh; Iron into steel, apparatus for converting, T. R. Scowder; Iron and making steel, apparatus for refining, T. S. C. Lowe; Jack, lifting, J. J. Stuart; Jack, lifting, D. Shumusk; Ladder, J. N. Valley; Lamp, O. N. Perkins; Lamp heater for nursery flasks, S. Hughes; Lard, apparatus for cooling, J. Ring; Lathe, metal turning, F. W. Pomroy; Lead, manufacture of the subacetate of, L. Brumlen; Lubricator for car axles, G. A. Brannan; Meat and vegetable cutter, J. Stepp; Medical compound, T. B. Hick; Medical compound, W. A. Smith; Medical compound, Mayon and Champlain; Medical compound, J. W. Gray; Medical compound or bitters, G. W. Brown; Mill spindles, etc., bush for, R. E. and F. A. Howe; Mortar mixer, portable, H. Rosen; Movement, mechanical, A. B. Hendryx; Nozzle and turn pipe, hydraulic, D. L. Gorman; Nut, lock, J. S. Kirkpatrick.

EYEGGLASS.—Arabella Siss, of Edgewater, N. Y.—This invention has for its object to improve eyeglasses in such a manner that the spring connecting the frames cannot become bent to one side or twisted out of shape. It consists in adapting the pin, on which the glasses hook when folded, to project from either side of the handle or frame, so that the hook on the other frame may be secured to either side *ad libitum*. This gives sufficient change in the positions of the spring when folded as to prevent its being twisted in one direction only. The pin is made of the usual length, and is fitted loosely through the handle, so that it can be pushed from one side to the other. It is also headed at both ends to adapt it to retain its places on the hook and frame.

STONE GATHERER.—Benjamin R. Tupper, of Odessa, Michigan.—This invention consists in a peculiar mode of combining rake teeth and revolving arms so as to transfer stones from the surface of the ground to an endless carrier. The lower end of the truck of the gatherer is armed with strong curved metal teeth, adapted to run under the stones and gather them upon their upper sides. Arms are arranged to revolve on the truck axle and pass between the teeth in such a manner as to force the stones up and along them on to the endless carrier, by which they are delivered into a box.

CELERY COLLAR.—John Simpson, of York, Eng. assignor to himself and William Blake, of Liverpool, Eng.—This invention relates to a new shield or collar for celery and other plants, by the use of which they are kept from unduly expanding, are bleached, and prevented from becoming soiled. The invention consists in making a collar of stout paper perforated with a row of holes and provided at one end with a hook. It is placed around the plant with the hook fitted through one aperture, and allows the plant to become expanded during growth by bearing against the collar and causing the hook to tear its way from the inner gradually to the outer aperture. It protects the plant and holds its branches properly elevated.

HORSE POWER.—Samuel E. Tooley, of Delphi, N. Y.—This invention consists of a horse power for driving crosscut saw machines and other machinery, in which there is a simple and economical duplicate arrangement for working two crosscut saws, together with a shifting gear for connecting and disconnecting the saws alternately; by which means one is kept at work while the other is resting and the log is being adjusted, so that the team and attendant are employed the whole time, and the stopping and starting, necessary when only one saw is used, is avoided.

ELECTRO-MAGNETIC APPARATUS.—Rudolph Sayer, of New York city.—This invention relates to several improvements in the construction and arrangement of electric apparatus to be used for medical or other purposes; it consists in making the vibrating hammer or armature of graduated form, and in combining with it a vertically adjustable frame which can be set opposite any one of its steps and thereby enlarge or diminish its vibrations. The interval of the electric shocks can be conveniently changed by means of the adjustable frame, which is further connected with an index showing the degree of motion allowed to the hammer. The invention also consists in a new swivel post, which connects with the conductors from the magnetic coil and sleeve, and with the wires which connect with the patient or with the article to be acted upon. By turning this post the direction of the current through the last named wires can be reversed, and it has metal arms connecting with the branched ends of the conductors, respectively, in the desired manner. There is also a vibrating wire frame, whereby the primary current can be used alone whenever desired.

REEL.—Louis Weins, of Rhine, Wis.—This invention relates to a new arrangement of yarn reel, which can be placed in a horizontal or vertical position, according to the purposes for which it is intended. It consists in a new manner of fitting the shaft through a swivel ring, so that it can, with said ring, be swung into the desired position and there fastened in sockets provided for its reception.

HOT BLAST OVEN PIPE.—J. King McLanahan, of Hollidaysburg, Pa.—This is an improvement in the mode of casting the upper ends of the diaphragm pipes used in hot air ovens for blast furnaces, so as to dispense with the cemented plugs as heretofore, made and obviate the necessity of cooling down the blast furnace on their burning out. The invention presents, as a new manufacture, a diaphragm pipe with the top cast on solid with the sides or cylindrical parts.

SAW MILL.—James M. Rees, Scott, Ohio.—This improvement has for its object the regulation of the sweep or rake of the saw, which the inventor claims to have effected by the use of saw guides which are carried by fender posts. It is an ingenious invention.

RAILROAD AND MARINE SIGNAL LAMP.—James F. Veronee, of Charleston, S. C.—This invention has for its object to improve the construction of railroad and marine signal lamps so as to make them more convenient and effective in use, by throwing the light stronger and thus further than lamps constructed in the ordinary manner; and it consists in various combinations of cylindrical and flaring or conical hand reflectors with the lenses and illuminating lamps.

DOOR KNOB LOCK.—C. M. Jordan, of Stillwater, Mich.—This invention provides a door knob spindle, so arranged that when the inner knob is drawn away from the door, the spindle cannot be turned or moved longitudinally, thus effectually preventing the door from being opened from the outside. By pushing the inner knob towards the door, the spindle is put into position to throw the bolt, and can be operated by either knob and the door opened.

LOOM.—James Short, of New Brunswick, N. J.—This invention relates to a positive motion loom with a suitable number of shuttles, of which either one can be used at any one time, all others being held at rest until they are to be used one after another, which permits the weaving of many colored fabrics on a loom whose length of shuttle motion is unlimited. An important feature of the invention consists in imparting to the belt such motion and in so connecting it that it can, after having moved a shuttle in one direction, be continued in the same direction to bring another shuttle from the end whence the former was conveyed; although, if required, the belt may also be moved in the opposite direction either to return the first shuttle or to move another on the return stroke. By this motion of the belt in either direction, in connection with a suitable box shifting mechanism, the weaver is enabled to take at any one stage of the operation any one shuttle from either end of the loom for use. Thus, whatever the number of shuttles employed in a fabric and the number of different colored spools they carry, the operator has power to use them in suitable succession. There are several other improvements in this machine. Thus there is a cam mechanism for automatically regulating the belt motion on a predetermined design. With similar purpose the above mentioned vibrating frames are moved to bring the several shuttles into action in the required succession.

COTTON SEED PLANTER.—William Gessner, of Cape Girardeau, Mo.—This invention relates to a new drop arrangement and to a new combination of the furrow opening and closing devices that pertain to a cotton planter, and its object is to simplify the operations of separating and dropping the seeds and embedding the same in the soil. It consists principally in providing the double conical drop drum with circular rows of projecting teeth, and in combining it with a box shaped upper attachment of the drop tube, whose back plate extends up to the drum and is notched to admit the teeth. No seed can thus enter the tube except what is just in front of the teeth. The necessary separation of the adhesive cotton seeds is thus effected and waste of seed prevented. The invention also consists in two mold boards forming the ridge of a scraper for opening the furrow, and in a roller for closing it.

CLOTH CUTTING MACHINE.—Solomon M. Eiseman, of New York city.—This invention furnishes an improved machine for cutting cloth, paper, woven or felted fabrics, metals, and substances of all kinds formed in sheets, into any desired form. The cutting knives are operated by means of a gravitating cutter head so arranged and constructed that, by the fall of the cutter head and knives, several thicknesses or sheets of the material are simultaneously cut. The knives are made of spring steel or other elastic material, so that they take any desired curve. In using the machine the pattern of the piece to be cut is drawn upon the face of the plate. Knives of the proper length are then adjusted to the pattern by means of studs and belts, as many studs being used as may be required to bring the knives to and hold them in the proper shape.

HEATING ATTACHMENT FOR COOKING STOVE.—John Beeler, of Brownsville, Mo., assignor to himself and Morris Monheim.—This invention has for its object to supply a heater attachment to cooking stoves, whereby the surplus heat of the latter is utilized for baking, for keeping irons hot, and for other similar purposes. The heater, which is placed on the top of the stove, is made hollow at its sides and top, thereby forming an outer heating compartment and an inner receiving space. The hot gases from the stove are admitted through slides to the heating compartment and are allowed to escape through a pipe into the stove pipe. When not wanted, it can be removed.

HARVESTER.—Nathan T. Veatch, Camden, Ill.—This improved reaper consists in the construction and combination of various parts of a reaping machine which can be arranged for use either in reaping or mowing, the change from one form to another being easily made. When the machine is adjusted for use as a reaper, the outer end of a finger bar is supported by a grain wheel, upon the upper end of the standard of which is formed a circular toothed or notched face, which fits upon a similar faced arm pivoted to the outer end of the said finger bar. When the machine is to be adjusted for use as a mower, the platforms, reel, grain dividers, and grain wheel are taken off.

STARCHING MACHINE.—Ulrich W. Carrell, of Belleville, N. J.—This invention furnishes an improved machine for starching clothes, which is designed especially for laundry use, for starching the bosoms and cuffs of shirts; it consists principally in arranging two perforated rubbers worked by a crank, between which the bosoms and cuffs are inserted after being dipped in the starch, and by which the starch is rubbed thoroughly into and through the clothes, and the surplus squeezed out.

SEWING MACHINE.—Volney Parks, of Fort Wayne, Ind.—This invention relates to an improvement in the class of sewing machines in which a hollow circular rotating hook is employed to receive a case adapted to contain an ordinary thread spool, the arrangement being such as to allow the hook to form a loop from the upper thread and carry it completely around the spool case or bobbin. In this invention, the rotating hook is provided with a rounded peripheral projection or cam surface to adapt it to act upon a bar which is connected with the spool case, arranged within the rotating hook, so as to cause the retraction of the case and permit the passage of the upper thread around it.

VACUUM CLOTHES WASHER.—McKewen Johnstone, of Spartanburg, S. C.—This invention consists of a wash tub with a chamber situated between an upper and lower bottom; a pump, and valves in the bottoms; all so arranged that a vacuum may be formed under the clothes, which are supported on a wire screen above the top of the vacuum chamber, and soap water in the tub forced through the clothes into the vacuum chamber by atmospheric pressure when a valve at the top of the chamber is suddenly opened; and so that after washing sufficiently the air may be forced through in like manner to dry them. From the vacuum chamber the water may be pumped back into the tub and the operation repeated as long as the state of the water will allow, after which, by the same pump, the foul water is discharged from the machine.

RAILWAY CAR BRAKE.—James S. Lamar, of Augusta, Ga.—In this improved car brake apparatus there are a friction wheel and drum on each car, with the brake chain connected to the drum and with toggle-jointed bars and a lever for throwing the friction wheel into gear with the axle for winding up the drum and putting on the brake; the brakes of all the cars are connected by a long cord or chain with a drum on the locomotive or tender, which is also actuated by the axle through the medium of a friction wheel, and this friction wheel is, in like manner, thrown into gear by a lever and toggle-jointed bars; this lever is operated by the brakeman by a cord, rod, or other contrivance provided for the purpose, and arranged to be actuated in the cabin. The long cord connecting all the brake levers is arranged in a peculiar manner, and works with equal efficiency whether the car couplings are slack and the cars are close together, or whether they are taut and the train is extended to its greatest length.

ROTARY STEAM ENGINE.—Robert T. P. Allen, Farmdale, Ky.—The object of this invention is to obviate many of the objections to rotary engines heretofore made; it consists in a stationary surrounding casing, in which the steam drum revolves, and in which it is made steam tight by packing. Within the drum is a stationary steam pipe from the boiler; and a variable cut-off surrounds the steam pipe, around which the steam drum revolves. The cut-off tube is connected with the governor of the engine by means of an arm, by which it is partially rotated on the steam pipe. Steam ports in the pipe and in the cut-off tube open to steam ways or channels in the steam drum. The steam drum is a round cylinder with two cams which form two offsets or pistons on its periphery. The channels discharge the steam through these offsets against sliding abutments in the casing. As the drum revolves, the abutments are forced through the casing by the cams so as to allow the drum to continue its revolution. Springs are attached to the casing at one end and to the abutments at the other, so as to force the abutments back into the steam space and in contact with the drum, as soon as the offsets have passed by.

FRUIT PICKER.—David W. Thompson, St. Joseph, Mo.—The invention relates to that class of fruit pickers provided with a long handle, a vessel at the upper end to receive the fruit, and some means to detach the said fruit from the branches. The invention consists in the mode of detaching the fruit by one or more traps on the upper edge of the vessel, and in the mode of attaching the handle so that any desired lean or inclination may be given to the fruit-receiving vessel.

INVALID BEDSTEAD.—Henry A. Scott, Winchester, N. H., assignor to himself and Howard B. Hunt, Athol, Mass.—This invention relates to certain improvements on the invalid bedstead for which letters patent were granted the present inventor April 9, 1872. Its object is to obtain the transmission of a reaper power from the operating crank to the vertically adjustable frame, as the direct turning of the original geared cams is frequently too difficult for persons of little strength. The present invention consists in the combination, with the geared segments that hold the elevating arms, of a longitudinal shaft carrying pinions that mesh into them, and of a transverse operating shaft, which is, by worm and worm wheel, connected with the longitudinal shaft to turn the same. By this transmitting mechanism, the labor of elevating or lowering the invalid can be easily performed.

LOOK NUT.—Levi Arnold, Belchertown, and James B. Atwood, Palmer, Mass.—This invention consists of a nut divided in halves or more pieces in the lengthwise direction of the bolt, each part having a portion of its exterior surface constructed in a concentric line and a portion constructed in an eccentric line; with this divided nut is combined a washer with concentric and eccentric parts in the wall of the hole through it corresponding to the concentric and eccentric parts of the sectional nut; so that, after the nut is screwed home, the washer, when turned so as to force its eccentric parts up to the eccentric parts of the nut, binds the threads of the nut in the threads of the screw so as to hold it on the bolt by friction. The eccentric parts of the washer are turned entirely up on to the concentric parts of the nut, and are held thereon against sliding back, as they would do if allowed to rest on the eccentric parts of the nut. The washer is prevented from coming off the nut by a collar on the latter.

HEAD BLOCK FOR CARRIAGE.—Frederick Van Patten, Auburn, N. Y., assignor to himself, M. S. Fitch, and E. D. Clapp, of same place.—The object of this invention is to furnish to carriage makers what is known as the T-plate or head block in a more perfect form and at a cheaper rate than it has heretofore been obtained; it consists in a head block stamped or pressed out by machinery to a perfect form, with the bolt holes formed with bosses or raised portions around them so as to secure extra strength. The ends are left unfinished so that they may afterwards be drawn out to proper length and size.

SLIDE VALVE.—Frederick Glasson, New York city, and William Gillfillan, Paterson, N. J.—This invention refers to that class of slide valves used in steam force pumps or other steam engines, which, being actuated by tappets or stops on moving parts therein, are required to perform their function with as little lost motion of the tappets as possible, in order to reverse the engine and pass the dead point thereof; it consists in the construction of the valve seat and its fixed abutment, and in the combination with the latter of a valve of peculiar construction, which is reciprocated by the force of the steam acting between it and the said abutment.

Table listing various mechanical patents and their inventors, including items like 'Nuts, machine for tapping', 'Ore separator', 'Paper stock', etc.

TRADE MARKS REGISTERED. List of registered trademarks including 'RAZOR STROP', 'WINE TONIC', 'BRIDLE BITS', etc.

SCHEDULE OF PATENT FEES. Table detailing fees for various patent services such as 'On each Caveat', 'On filing each application for a Patent', etc.

For Copy of Claim of any Patent issued within 30 years... A sketch from the model or drawing, relating to such portion of a machine as the Claim covers, from...

MUNN & CO., Patent Solicitors, 37 Park Row, New York.

APPLICATIONS FOR EXTENSIONS. Applications have been duly filed, and are now pending, for the extension of the following Letters Patent.

EXTENSIONS GRANTED. 20,345.—CUTTER HEAD AND REST FOR IRREGULAR FORMS.—J. P. Grosvenor.

DISCLAIMER. 20,345.—CUTTER HEAD AND REST FOR IRREGULAR FORMS.—J. P. Grosvenor. Filed August 19, 1872.

Value of Extended Patents. Did patentees realize the fact that their inventions are likely to be more productive of profit during the seven years of extension than the first full term for which their patents were granted...

MUNN & CO., 37 Park Row, N. Y.

Inventions Patented in England by Americans. [Compiled from the Commissioners of Patents' Journal.] From July 23 to August 12, 1872, inclusive.

SEWING MACHINE.—S. W. Wardwell, Jr., St. Louis, Mo. SEWING MACHINE.—T. J. Harper, Atlanta, Ga. SMUT MACHINE, ETC.—S. Howes, A. & N. Bacoock, C. Ewell, Silver Creek, N. Y.

FOREIGN PATENTS—A HINT TO PATENTEES.

It is generally much better to apply for foreign patents simultaneously with the application in the United States. If this cannot be conveniently done, as little time as possible should be lost after the patent is issued...

MUNN & CO., 37 Park Row, N. Y. Circulars, with full information on foreign patents, furnished free.

NEW PATENT LAW IN CANADA.

By the terms of the new patent law of Canada (taking effect September 1st, 1872) patents are to be granted in Canada to American citizens on the most favorable terms.

The patent may be taken out either for five years (government fee \$20), or for ten years (government fee \$40) or for fifteen years (government fee \$60).

In order to apply for a patent in Canada, the applicant must furnish a model, specification and duplicate drawings, substantially the same as in applying for an American patent.

American inventions, even if already patented in this country, can be patented in Canada provided the American patent is not more than one year old.

All persons who desire to take out patents in Canada are requested to communicate with Munn & Co., 37 Park Row, N. Y., who will give prompt attention to the business and furnish pamphlets of instruction free.

Messrs. Munn & Co., have had twenty-five years experience in the business of obtaining American and Foreign Patents for inventors; they have special agencies in nearly all countries where patents are granted.

MUNN & CO., 37 Park Row, N. Y.

NEW BOOKS AND PUBLICATIONS.

THE CHANDLER ELEMENTS OF DRAWING. By John S. Woodman, of Dartmouth College. Boston: Ginn Brothers.

REPORTS OF THE PRESIDENT, SECRETARY, AND DEPARTMENTS OF THE MASSACHUSETTS INSTITUTE OF TECHNOLOGY, FOR 1871-2. Boston, Mass.

These documents are clear and concise accounts of the valuable work done by this society during the past year. It should be read by all who are interested in the all important question of technical education.

CAMPAIGN HANDBOOK AND CITIZEN'S MANUAL. By Frank Champion, Counselor at Law. \$1.25. F. C. Bliss & Co., Hartford, Conn.

This is a little volume containing facts, dates, and figures which illustrate the working of the Constitution of the United States, together with biographical sketches of the candidates for the Presidency and Vice-Presidency; and it is compiled especially for all persons, being free from any personal or party bias. It is copiously illustrated.

Advertisements.

RATES OF ADVERTISING. Back Page \$1.00 a line, Inside Page 75 cents a line for each insertion.

'Buckeye' Hominy Mill. IN THE WORKING OF THIS MILL the Corn requires no preparation except shelling. It has a regular feed and discharge, and needs but little attention.

BLIND SLAT PLANERS, best in use. Circulars free. C. P. S. WARDWELL, Lake Village, N. H.

FOR LOCOMOTIVE and Stationary Engine Slide Valve Seat Planers, Long's Patent, and the best Hand Planer in use, address H. C. PEASE & CO., Worcester, Mass.

FOR CASE-HARDENING. Hydro-Carbonated Bone Black, containing three times the Carburing Power of the substances ordinarily used, producing uniformly a hard tough case to the depth of a half inch, if desired.

LARGE PROFITS, and no competition. Agents wanted everywhere to sell our patent Freight Elevating Hand Truck. It saves hogs, loading and unloading, and all strain of lifting bags, barrels, boxes, bales, &c.

Fairmount Machine Works, OFFICE, 2106 WOOD STREET, Philadelphia, Pa. MANUFACTURE AS SPECIALTIES: Power Looms, with improved Box Motions.

ANY ONE having a Patent Right for Sale, address "NATIONAL P. R. AGENCY, Philadelphia, Pa. \$100 per week. Agents wanted. Address as above.

BURDON IRON WORKS.—Manufacturers of Pumping Engines for Water Works, High and low Pressure Engines, Portable Engines and Boilers of all kinds, Sugar Mills, Screw, Lever, Drop, and Hydraulic Presses, Machinery in general. HUBBARD & WHITTAKER, 10 Front St., Brooklyn, N. Y.

DON'T BUY STEAM ENGINES OR BOILERS without first sending for "THE STEAM USER'S MANUAL," sent free on application to E. E. ROBERTS, Consulting Engineer, 15 Wall St., New York.

RISDON'S IMPROVED Turbine Water Wheel. Is Cheap, simple, strong and durable: upon a test has yielded over 84 per cent at full gate, and over 76 per cent at seven-eighths gate.

WOODWORTH SURFACE PLANERS, \$125. Woodworth Planers and Matchers, \$350. HILLS & HOAG, 32 Courtland St., New York.

CINCINNATI BRASS WORKS.—Engineers and Steam Fitters' Brass Work, Best Quality at lowest Prices. F. LUNKENHEIMER, Prop'r.

PORTABLE STEAM ENGINES, COMBINING the maximum of efficiency, durability and economy, with the minimum of weight and price. They are widely and favorably known, more than 900 being in use.

Highest Premium awarded by American Inst. Fair, 1871.

72 lbs. Metal in the 100 lbs. Warranted Fire Proof. 500 lbs. N. Y. TRADE MARK.

An Indestructible Coating for Iron, Tin and Wood.

PRINCE'S METALLIC PAINT is acknowledged, wherever known, to be the BEST & CHEAPEST PAINT in the market.

N. Y. CENTRAL & HUDSON RIVER R.R. CO. SUPPLY DEPARTMENT, Albany, N. Y., Oct. 25, 1871. "Messrs. Prince & Bass, 96 Cedar St., N. Y."

Office of J. B. & J. M. CORNELL, PLAIN & ORNAMENTAL IRON WORKS, New York, Nov. 10, 1871. "Messrs. Prince & Bass—Gentlemen: We have used the Prince's Metallic Paint for several years, and believe it to be the best metallic paint for iron work now in use."

IMPROVED FOOT LATHES, Slide Rests, Hand Planers, Scroll Saws. Superior to all others. Selling every where. Catalogues free. N. H. BALDWIN, Laconia, N. H.

MODELS FOR THE PATENT OFFICE. Mand experimental machinery of all kinds. HOLSKE MACHINE CO., 279 Cherry St., New York, near Jefferson St. & special shop for Patent Models. Many years experience. Refer to Scientific American Office.

THE ONLY MODE of Disposing of Patents. See Patent Right Gazette. Address U. S. Patent Right Association, 94 Chambers Street, P. O. Box 4544, New York.

\$100 to 250 per month guaranteed sure to Agents everywhere selling our new seven strand White Platina Clothes Lines. Sells readily at every house. Samples free. Address the GIRARD WIRE MILLS, Philadelphia, Pa.

WOODWARD'S COUNTRY HOMES. 150 DESIGNS and PLANS for Houses of moderate cost. \$1.50, post paid. ORANGE JUDD & CO., PUBLISHERS, 245 Broadway, N. Y. Send for Catalogue of all books on Architecture, Agriculture, Field Sports and the Horse.

AGENTS WANTED. Agents make more money at work for us than at anything else. Particulars free. G. STINSON & Co., Fine Art Publishers, Portland, Me.

GREAT WESTERN GUN WORKS. P. O. BOX 1438 PITTSBURGH, PA. Breech-Loading Shot-Guns, \$40 to \$300. Double Shot guns, \$8 to \$150. Single Guns, \$3 to \$20. Rifles, \$8 to \$75. Revolvers, \$6 to \$25. SEND STAMP FOR PRICE LIST. Army guns, Revolvers, etc., bought or traded for.

OTIS' SAFETY HOISTING Machinery. OTIS, BROS. & CO. No. 248 BROADWAY, NEW YORK.

NEW PATTERNS. MACHINISTS' TOOLS—all sizes—at low prices. E. & R. J. GOULD, 97 to 113 N. J. R. R. Ave., Newark, N. J.

PLATINUM H. M. RAYNOR, 25 Bond St., New York. For all Laboratory and Manufacturing purposes.

Niagara Steam Pump.
CHAS. B. HARDICK,
23 Adams st., Brooklyn, N. Y.

WOODBURY'S PATENT
Planing and Matching
and Molding Machines, Gray & Wood's Planers, Self-oiling
Saw Arbors, and other wood working machinery.
S. A. WOODS, 61 Liberty street, N. Y.;
Send for Circulars. 67 Sudbury street, Boston

RIVERVIEW Military Academy, Pough-
keepsie, N. Y. A thorough-going school for boys.

MACHINERY, NEW and 2d-HAND.—
Send for Circular. CHAS. PLACK
& CO., 80 Vesey st., New York.

BUY BARBER'S BIT BRACE.

NICKEL SALTS, for Plating, best quality,
sold in all quantities by L. & J. W. FEUCHT-
WANGER, 55 Cedar St., New York.

SCHENCK'S PATENT
WATER-PROOF
TAGS
No. 30 ANN'S
NEW YORK

You ask WHY we can sell
First Class Octavo Pianos for
\$290? We answer—It costs
less than \$300 to make any \$300
Piano sold through Agents, all
of whom make 100 per cent. profit.
We have no Agents, but ship
direct to families at Factory
price, and warrant Five Years.
Send for Illustrated Circular, in
which we refer to 800 Bankers,
Merchants, &c. (some of whom
you may know) using our Pianos in 40 States and Territories.
U. S. Piano Co., 353 Broadway, New York.

P. BLAISDELL & Co.,
MANUFACTURERS OF FIRST CLASS
MACHINISTS' TOOLS. Send for Circulars
Jackson st., Worcester, Mass.

STEPTOE, MCFARLAN & CO.,
Manufacturers of the most improved Patent Daniels,
Woodworth & Farrar Planers, Sash and Moulding, Ten-
oning and Mortising Machines, Wood-turning Lathes,
and every variety of Wood-working Machinery. Cuts
and prices sent on application. Warehouse and Manu-
factory, No. 214 to 220 West Second Street, Cincinnati, O.

MANGANESE OXIDE, for Glass and Steel
Makers, Oil Boilers and Gas, best quality, imported
by L. & J. W. FEUCHTWANGER, 55 Cedar St., New York.

RING SPINNING
IMPROVED SPINDLES—9,000 revolutions per minute.
Bobbin driven positive. BRIDESBURG MANUFAC-
TURING COMPANY, Philadelphia, Pa.

TRUE TIME FOR \$1.—50,000 SOLD.
MAGNETIC TIME-KEEPER, COMPASS AND IN-
STRUMENT for the pocket of every traveler, trader, boy, farmer, and for
EVERYBODY wanting a reliable time-keeper, and also a superior
compass. Usual watches, steel works, glass crystal, all in a neat
OXBIDE case. WARRANTED to denote correct time and to keep
in order—fully used—for two years. Nothing like it. The per-
fect triumph of watchmaking will be seen in a neat case, prepaid to any
address, for only \$1.00. Circulars sent free. Send for one from
the Sole American Agent, KING & CO., Merchants, Va.
No. 10, BURLINGAME ST., BOSTON, MASS.

ACID FLUORIC, for Glass and Metal Etch-
ing, best quality, manufactured by L. & J. W.
FEUCHTWANGER, 55 Cedar St., New York.

F. K. PHOENIX, Bloomington Nursery, Ill.;
600 acres; 21st year; 12 Green-Houses, Trees, BULBS,
HEDGE PLANTS, Nursery Stock; 4 Catalogues, 20 cts.

ORIGINAL PATENT AGENCY—Estab.
1839. Patents Sold. Send for our Circular and List.
E. H. GIBBS & CO., 11 Wall Street, New York.

BUERK'S WATCHMAN'S TIME DE-
TECTOR.—Important for all large Corporations and
Manufacturing concerns—capable of controlling with
the utmost accuracy the motion of a watchman of
petroleum, as the same reaches different stations of his
beat. Send for a Circular. P. O. Box 1,057 Boston, Mass.
N. B.—This detector is covered by two U. S. Patents
Parties using or selling these instruments without authori-
zation from me will be dealt with according to law.

SUPERIOR SAFETY FUSE FOR BLAST-
ING. Cotton, Hemp, Single and Double Tape man-
ufactured and constantly on hand. Send for sample and
prices. Address F. M. ALFORD, Avon, Conn.

MARYLAND INSTITUTE, BALTIMORE.
TWENTY-FIFTH ANNUAL EXHIBITION
Will open October 1 and close October 31, 1872. Articles for
deposit received September 23 to 28, inclusive. Gold,
Silver, and Bronze Medals will be awarded, also a Gold
Medal of Honor. Power, Shuffling, and Belling furnished
free of charge. Articles of merit or utility in all the
useful or fine arts, are solicited. Send for circulars and
detailed information. C. W. BENTLEY,
President and Chairman of Committee.

"PRACTICAL SUGGESTIONS ON THE
SALE OF PATENTS, WITH FORMS AND U. S.
CENSUS." A book invaluable to patentees—the fruit of
experience and observation—explains all kinds of sale-
able rights, how to compute value of invention, how to
find buyers, points of patent law; has complete patent
forms and official census. On tinted paper, red-line bor-
ders. Warmly commended by inventors and press. Spe-
cially prepared for the Scientific American. Price, 25
cents. W. E. SIMONDS, Hartford, Ct.

Milling Machines.
STANDARD, UNIVERSAL, INDEX AND PLAIN.
Send for illustrated catalogue to the BRAINARD MILLING
MACHINE COMPANY, 90 Milk St., Boston, Mass.

T. R. BAILEY & VAIL, Lockport, N. Y.,
Manufacturers of Gauge Lathes, Chair Machinery,
Sash and Shingle Machines, Engine Lathes, Key Seat
Cutting Machines, Upright Drills, &c. &c.

PATENT IMPROVED
VARIETY MOLDING MACHINERY
And Adjustable
CIRCULAR SAW BENCHES.
For Machines and addresses
J. P. GROSVENOR, Lowell, Mass

FOOT LATHES.—T. SHANKS, Baltimore, Md.

PUNCHING PRESSES. For the Best and Cheapest, Ad-
dress THE STILES & PARKER
PRESS CO., MIDDLETOWN, CONN.

\$10 from 50 cts.
12 SAMPLES sent (postage paid) for Fifty
Cents, that retail easily for Ten Dollars.
R. L. WOLCOTT, No. 181 Chatham Square, N. Y.

PROPELLER PUMP
Capacity for a 1,000 to 100,000 gallons per minute. No
other improved machinery. Address Wm. B.
& C. Bevy, 67 North Front St., Philadelphia, Pa.

\$5,000,000.

PRIME INVESTMENT

LOW PRICE.

CHICAGO

CANADA SOUTHERN

First Mortgage Sinking
Fund 30 Years'

7 PER CENT. GOLD BONDS

90 & ACCRUED INTEREST.

Interest Payable April and October,
at Union Trust Company.

This road is the western link in the new AIR LINE
from BUFFALO to CHICAGO, and runs from the De-
troit River to Chicago in nearly a straight line.

The road is a part of the same line as the Canada
Southern, and is being built by the same men, viz.: Mil-
ton Courtright, John F. Tracy, David Dows, Wm. L.
Scott, Henry Farnam, R. A. Forsyth, John M. Burke,
M. L. Sykes, Jr., all Directors either in the Chicago and
Northwest, or the Chicago, Rock Island and Pacific;
Geo. Opdyke, of the Midland Road; Sidney Dillon, Dan-
iel Drew, John Ross, David Stewart, Samuel J. Tilden
Kenyon Cox, and other prominent railroad men.

The Road, like the Canada Southern, will have steel
rails (60 pounds to the yard) throughout; is practically
straight and level; much shorter, and can be run more
quickly and with greater safety than any other road con-
necting Buffalo and Chicago.

Twenty-five miles are finished and running; seventy-
five miles more are so far advanced as to be finished by
January 1st, and the entire road will be completed dur-
ing the ensuing year. Steel rails and ties for one-half
the entire road have already been purchased.

The builders of the road control enough of its Chicago
feeders to obtain for it a profitable business from the
start, having projected the line to accommodate ex-
isting business, and having seen the necessity for another
trunk line between Chicago and the Atlantic seaboard,
located expressly with the view of obtaining the cheap-
est transportation practicable.

The branch lines will make the shortest connections
between Chicago and Toledo, and Chicago and Detroit,
as well as between all these points and Buffalo.

The Canada Southern Bonds, in every particular like
these, were eagerly taken, the last of them several weeks
ago, by the best class of investors, and were on the mar-
ket a shorter time than any other railroad loan of like
amount for years past.

The proceeds of these bonds will com-
plete the entire line, and we recommend
them with the same confidence as we
did the Canada Southern, and regard
them as in every way a choice security.

Pamphlets and all information furnish
ed by

LEONARD, SHELDON & FOSTER,

BANKERS,
NO. 10 WALL ST., N. Y.

WINSLOW, LANIER & CO.,

BANKERS,
NO. 27 PINE ST. N. Y.

Peteler Portable Railroad Company,
OFFICE, 42 BROADWAY, NEW YORK.

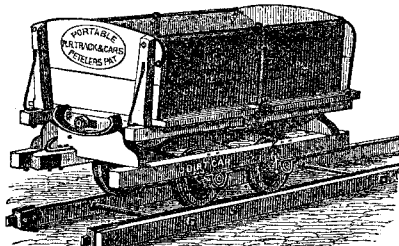

TO CONTRACTORS, MINERS, etc.
By this invention one horse does the work
often, and one man the work of eight.

The great labor-saving invention of the age.
CARS AND TRACKS FOR SALE.
Samples at the office, New Illustrated Circulars free.
State Rights for sale.
LOUISIANA PORTABLE RAILWAY COMPANY,
37 Carondelet Street,
New Orleans, La.,
WHERE STATE RIGHTS MAY BE OBTAINED.
J. B. BROWN,
170 La Salle Street, Chicago, Ill.

FRENCH RANGES,
Deane's Patent.
CEILSON'S NEW CONE FURNACES,
Wholesale and Retail,
BRAMHALL, DEANE & CO.,
295 Water St., New York.

THE "PHILADELPHIA"
HYDRAULIC JACK.
PISTON guided from both ends; all working
parts guarded from dust; single or double pumps.
cylinders, shafts, rocker arms, pistons, etc., entirely steel.
No. 14 N. 5th st., Philadelphia, } PHILIP S. JUSTICE.
No. 42 Cliff st., New York. }

Civil and Mechanical Engineering, at the
RENSSELAER POLYTECHNIC INSTITUTE, TROY, N. Y.
Instruction very practical. Advantages unsurpassed in
this country. Graduates obtain excellent positions.
Reopens Sept. 15th. For the Annual Register, contain-
ing improved course of study and full particu-
lar address PROF. CHARLES DROWNE, Director.

MASON'S PAT'T FRICTION CLUTCHES
are manufactured by Volney W. Mason & Co.,
Providence, R. I. Agents, L. B. BROOKS, 60 Cliff st.,
New York; TAPLIN, RICE & CO., Akron, Ohio.

WOOD CARPETING.
PARQUET AND INLAID FLOORS.
Send stamp for illustrated price list to the
NATIONAL WOOD MAN'G CO.,
942 Broadway, New York.

WATER or SOLUBLE GLASS, Silicates of
all kinds for Fireproofing, etc., manufactured by
L. & J. W. FEUCHTWANGER, 55 Cedar St., New York.

Whalen Turbine. No risks to purchaser. Send for
Pamphlet, free. SEYMOUR WHALEN & BRO., Ballston Spa, N. Y.

The Sun.
It Shines for All.
CHARLES A. DANA, EDITOR.

The Leading Independent Newspaper
of America.

THE SUN now circulates between 110,000
and 120,000 copies daily. It strikes at corrup-
tion wherever it exists, without regard to persons or
parties. It is a fearless advocate of the rights of the
people.

THE SUN was the first to expose the Tam-
many Frauds. Its exposures created the rebellion
of the Young Democracy, the precursor to the downfall
of the notorious Tammany Ring.

THE SUN was the first to expose the great
San Domingo annexation fraud. Its exposures con-
tributed to open the eyes of the United States Senate,
and save the people over \$7,000,000.

THE SUN was the first to expose Grant's
nepotism and gift-taking, which draped the Presi-
dential dignity with obloquy and shame.

THE SUN was the first to expose the oper-
ations of Bancroft Davis, the bribe-taker, and the
shameful influence of Spanish gold in making the Ameri-
can nation an accessory to the horrible butcheries of the
Cuban patriots.

THE SUN was the first to expose the cor-
ruption pervading the Navy, Post Office, and Indian
Departments. Under its exposures the chief of the In-
dian Ring was compelled to resign his office.

THE SUN was the first to expose Grant and
Casey's corruptions and usurpations in Louisiana.

THE SUN was the first to expose the enor-
mous robberies of the carpet-bag Government of
the South, and the true character of Grant's Ku-Klux
proclamations. Under its exposures, Congress has re-
fused to renege the Ku-Klux bill.

THE SUN was the first to nominate that
Champion of Honesty, Dr. HORACE GREELEY, for
President. Its effective support was followed by Dr.
GREELEY'S nomination.

As in the past, so in the future. **THE SUN** will be
no follower, but a leader in the great work of reform.
No thief, however high, or of whatever influence, will be
spared.

As a newspaper, **THE SUN** stands unrivaled. I
print all the news, and frequently the most important
in advance of its contemporaries. It is furnished to the
public at the cheapest possible rate. As an advertising
medium it is unequalled.

The Weekly Sun for the Presidential Cam-
paign.
THE WEEKLY SUN will be especially valuable during
the Presidential canvass.

It will contain full and interesting accounts of all im-
portant events that mark the progress of the campaign.
The union of independent voters of all parties to break
down Grantism and corruption, and rescue the Govern-
ment and the country, seems destined to be realized.

Such a combination is sure to sweep the field and
achieve a victory second only to the triumph of our
forefathers over the British armies and the British Gov-
ernment.

THE WEEKLY SUN is the cheapest journal in the world.
It contains eight pages of reading matter, and is in every
respect, both as a family and political newspaper, fully
equal to any other published in the country, not merely
in interest and ability, but in the quantity of useful in-
formation and pleasant entertainment which its columns
furnish.

THE WEEKLY SUN is furnished to subscribers at the
uniform rate of one dollar a year for each copy, always
payable in advance.

TERMS OF THE SUN.
DAILY, PER YEAR, TO MAIL SUBSCRIBERS.....\$6 00
SEMI-WEEKLY, PER YEAR..... 2 00
TEN COPIES TO ONE ADDRESS..... 15 00
TWENTY COPIES TO ONE ADDRESS..... 35 00
FIFTY COPIES TO ONE ADDRESS..... 80 00
WEEKLY, PER YEAR..... 1 00

THE WEEKLY SUN—a large eight page
sheet—for the half year embracing the Presi-
dential Campaign, only
HALF A DOLLAR.
Address, **THE SUN** NEW YORK CITY

"FOR SALE."

A RARE OPPORTUNITY.
The Machinery and Tools, complete, of a Gun and Pis-
tol Manufactory—such as Lathes, Milling and Edging
Machines; one, two, three, and four spindle Drills;
Screw Machines; Rifling and Stock Making Machinery;
in fact, a complete equipment of first class Machinery—
will be sold in one lot, or separately. For particulars,
address
GEO. PLACK & CO.,
121 Chambers & 103 Reade Sts., New York.

Machinery,
Wood and Iron Working of every kind. Leather and
Rubber Belting, Emery Wheels, Babbitt Metal, &c.
GEO. PLACK & CO., 121 Chambers & 103 Reade Sts. N. Y.

Machinists' Tools.
The largest and most complete assortment in this coun-
try, manufactured by
NEW YORK STEAM ENGINE COMPANY,
121 Chambers & 103 Reade Streets, New York.

Cold Rolled Shafting.
Best and most perfect Shafting ever made, constantly
on hand in large quantities, furnished in any lengths up
to 24 ft. Also, Pat. Coupling and Self-oiling adjustable
Hangers. 121 Chambers & 103 Reade Streets, New York.

Sturtevant Blowers
Of every size and description, constantly on hand.
GEO. PLACK & CO.,
121 Chambers & 103 Reade Streets, New York.

WILDER'S
Pat. Punching Presses
For Railway Shops, Agricultural Machine Shops, Boiler
Makers, Tinners, Brass Manufacturers, Silversmiths, &c.,
warranted the best produced. Send for Catalogue, &c.,
NEW YORK STEAM ENGINE CO.,
121 Chambers & 103 Reade St., N. Y.

1832. SCHENCK'S PATENT. 1871.
WOODWORTH PLANERS
And Re-Sawing Machines, Wood and Iron Working Ma-
chinery, Engines, Boilers, etc. JOHN B. SCHENCK'S
SONS, Matteawan, N. Y. and 118 Liberty st., New York.

WOOD-WORKING MACHINERY GEN-
erally. Specialties, Woodworth Planers and Rich-
ardson's Patent Improved Tenon Machines, Nos. 24 and
35 Central, corner Union st., Worcester, Mass.
WITHERBY RUGG & RICHARDSON.

RICHARDSON, MERIAM & CO.
Manufacturers of the latest improved Patent Dan-
iels' and Woodworth Planing Machines, Matching, Sash
and moldering, Tenoning, Mortising, Boring, Shaping, Ver-
tical, and Circular Re-sawing Machines, Saw Mills, Saw
Arbors, Scroll Saws, Railway Cut-off, and Rip-saw Ma-
chines, Spoke and Wood Turning Lathes, and various
other kinds of Wood-working Machinery. Catalogues
and price lists sent on application. Manufactory, Wor-
cester, Mass. Warehouse, 107 Liberty st. New York. 17 1

SHINGLE AND BARREL MACHINERY.—
Improved Law's Patent Shingle and Heading Ma-
chine, simplest and best in use. Also, Shingle Heading
and Stave Jointers, Stave Equalizers, Heading Planers,
Turners, etc. Address TREVOR & CO., Lockport, N. Y.

STEAMPUMPS WRIGHT'S Bucket
Pumpers are the best.
Send for circular. Valley
Machine Co., Eastham-
pton, Mass.

Andrew's Patents.
Noiseless, Friction Grooved, or Geared Holst-
ers, suited to every want.
Safety Store Elevators. Prevent Accident, if
Hoops, Belt, and Engine break.
Smoke-Burning Safety Boilers.
Oscillating Engines, Double and Single, 1-2 to
100-Horse power.
Centrifugal Pumps, 100 to 100,000 Gallons
per Minute, Best Pumps in the World, pass
sand, silt, gravel, coal, grain, etc., with-
out injury.
All Light, Simple, Durable, and Economical.
Send for Circulars.
WM. D. ANDREWS & BRO.,
414 Water street, New York.

Wrought Iron
BEAMS & GIRDERS
THE Union Iron Mills, Pittsburgh, Pa. The
attention of Engineers and Architects is called to
our improved Wrought-iron Beams and Girders (patent-
ed), in which the compound welds between the stem and
flanges, which have proved so objectionable in the old
mode of manufacturing, are entirely avoided, we are pre-
pared to furnish all sizes at terms as favorable as can be
obtained elsewhere. For descriptive lithograph address
Carnegie, Kloman & Co. Union Iron Mills Pittsburgh, Pa.

EDWARD H. HOSKIN,
CONSULTING AND ANALYTICAL CHEMIST,
Lowell, Mass.
Chemistry as applied to the Arts, Manufactures and
Medicine.

SCIENTIFIC AMERICAN.
The Best Mechanical Paper in the World.

A year's numbers contain over 800 pages and several
hundred engravings of new machines, useful and novel
inventions, manufacturing establishments, tools, and
processes.

The SCIENTIFIC AMERICAN is devoted to the inter-
ests of Popular Science, the Mechanic Arts, Manu-
factures, Inventions, Agriculture, Commerce, and the In-
dustrial pursuits generally, and is valuable and instruc-
tive not only in the Workshop and Manufactory, but also
in the Household, the Library, and the Reading Room.

TERMS.
One copy, one year \$3.00
One copy, six months 1.50
One copy, four months 1.00
CLUB RATES { Ten copies, one year, each \$2.50 25.00
Over ten copies, same rate, each 2.50 25.00
One copy of Scientific American for one year, and
one copy of engraving, "Men of Progress," 10.00
One copy of Scientific American for one year,
and one copy of "Science Record," 4.00
Ten copies of "Science Record," and ten copies
of the Scientific American for one year 35.00

CLUB PREMIUMS.
Any person who sends us a yearly club of ten or more
copies, at the foregoing club rates, will be entitled to one
copy, gratis, of the large steel plate engraving, "Men of
Progress."

Remit by postal order, draft or express.
The postage on the Scientific American is five cents per
quarter, payable at the office where received. Canada
subscribers must remit, with subscription, 25 cents extra
to pay postage.

Address all letters, and make all Post Office orders or
drafts payable to

MUNN & CO.,
37 PARK ROW NEW YORK.

Advertisements

Advertisements will be admitted on this page at the rate of \$1.00 per line for each insertion. Engravings may head advertisements at the same rate per line by measurement, as the letter-press.

ASPHALTE ROOFING FELT.

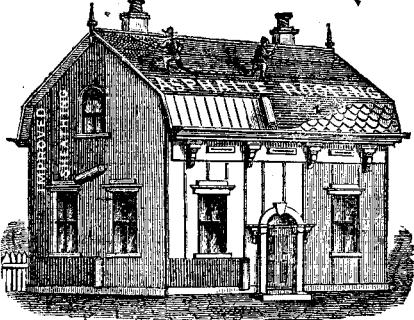

A CHEAP, durable, and light permanent Roofing for Rail Road Depots, Engine Houses, Foundries, etc. Also improved Sheathing Felt and general Roofing materials. Descriptive Circular, Samples, and Price List sent free, by E. H. MARTIN, 70 Maiden Lane & 9 Liberty St., New York.

PARTNER WANTED—One with a capital of \$25,000 or \$30,000 will find a safe and profitable investment in the lumber trade. Address O. E. GARRISON, St. Cloud, Stearns Co., Minnesota.

TO MANUFACTURERS AND MACHINISTS. THE BEST LOCATION in South West Missouri. Address C. C. ALLEN, Carthage, Mo.

PAT. EMERY GRINDERS, Union Solid Emery Wheels, Diamond Tools, and Improved Lathe Dogs. AMERICAN TWIST DRILL CO., Woonsocket, R. I.

THE HEALD & SISCO

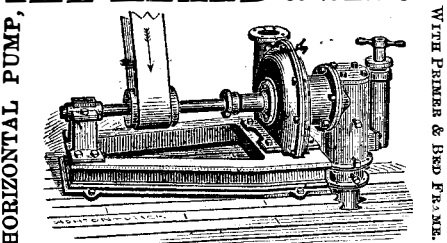

PATENT CENTRIFUGAL PUMPS, VERTICAL AND HORIZONTAL.

ARE USED ALL OVER THE UNITED STATES and the Canadas, and also in Great Britain. Send for our new Illustrated Pamphlet, containing hundreds of references to Tanners, Paper-makers, Contractors, Brick-makers, Distillers, etc., with 20 pages of the strongest possible testimony. (Ten pages of references.) Address HEALD, SISCO & CO., Baldwinville, N. Y. The H. & S. Pump took the First Premium at the recent Louisiana State Fair, over the most celebrated Centrifugal Pumps known in the United States, including one from New York. As a Wrecking-pump, and as an Irrigator, it is unrivalled, both for cheapness and efficiency. It also makes a splendid Fire Pump.

PATENT AUTOMATIC Screw Machine, and Machine Screw made to order at low rate. Circular free. F. CURTIS, Brattleboro, Vt.



The "three ply" Roofing is a perfect success; 20,000,000 feet in use. Circulars and samples sent "free." MICA ROOFING CO., 73 Maiden Lane, New York.

ONE POUND OF TEETH SAWS

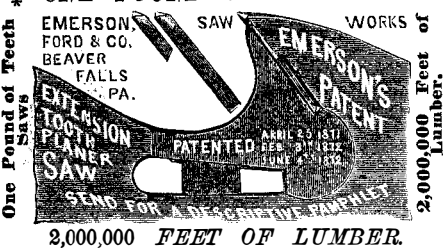

2,000,000 FEET OF LUMBER. PATENT FOR SALE, CHEAP—A thing required in every family. Apply to WILLIAM WATNER, No. 531 East Twelfth Street, New York City.

TO INVENTORS.

The "Consolidated Fruit Jar Company," having superior facilities for Manufacturing Spin, Pressed, or Stamped Sheet Metal Goods, make a Specialty of getting up Samples or Models as desired. Having connected with our Manufactory a Machine Shop, we can offer unusual facilities to those desiring to perfect their inventions. Address H. E. SHAFER, Treasurer, 49 Warren St., New York City.

WIRE ROPE.

JOHN A. ROEBLING'S SONS, MANUFACTURERS, TRENTON, N. J.

FOR Inclined Planes, Standing Ship Rigging, Bridges, Ferries, Stays, or Guyon Derricks and Cranes, Tiller Ropes, Sash Cords of Copper and Iron, Lightning Conductors of Copper. Special attention given to hoisting rope of all kinds for Mines and Elevators. Apply for circular, giving price and other information. Send for pamphlet on Transmission of Power by Wire Ropes. A large stock constantly on hand at New York Warehouse, No. 117 Liberty street.

ADJUSTABLE CIRCULARSAW Benches, Single or Double, for light or heavy work; something entirely new; four kinds. Warranted in every respect. Address, for illustrated Circular, DUNKLEE & ALLEN, Concord, N. H.

RANSOM SYPHON CONDENSER perfects and maintains vacuum on Steam Engines at cost of one per cent its value, and by its use Vacuum Pans are run with full vacuum without Air Pump. Send to WM. ALLEN, 51 Chardon St., Boston, for a personal call, or the Company, at Buffalo, N. Y., for a circular.

Canadian Inventors,

Under the new Patent Law can obtain patents on the same terms as citizens.

For full particulars address MUNN & CO., 37 Park Row, New York

The Bessemer Steel Works,

of John A. Griswold & Co. Troy, N. Y., May 3, 1872. B. F. Sturtevant, Boston, Mass. Dear Sir,—We have changed your No. 8 for your No. 9 Pressure Blower. The time in melting is about the same with either Blower. We are melting 225,000 lbs. (112 1/2 tons,) Pig Iron daily, (20 hours running time.) it works well. BARNEY MEE, Supt.

L. W. Pond---New Tools.

EXTRA HEAVY AND IMPROVED PATTERNS. LATHES, PLANERS, DRILLS, of all sizes; Vertical Boring Mills, ten feet swing, and under; Milling Machines, Gear and Bolt Cutters; Hand Punches and Shears for Iron. Office and Warerooms, 93 Liberty St., New York; Works at Worcester, Mass. A. C. STEBBINS, New York, Agent.

PATENT COLD ROLLED SHAFTING.

The fact that this shafting has 75 per cent greater strength, a finer finish, and is truer to gauge, than any other in use, renders it undoubtedly the most economical. We are also the sole manufacturers of the CELEBRATED COLLINS PAT. COUPLING, and furnish Pulleys, Hangers, etc., of the most approved styles. Price lists mailed on application to JONES & LAUGHLIN, 120 Water street, Pittsburgh, Pa. 199 S. Canal st., Chicago. Stocks of this shafting in store and for sale by FULLER, DANA & FITZ, Boston, Mass. GEO. PLACE & CO., 128 Chambers street, N. Y. PIERCE & WHALING, Milwaukee, Wis.

MACHINERY S. N. HARTWELL, Eng'r. Steam Engines, Steam Pumps & Machinists' Tools, 93 Liberty St., N. Y.

WHEELS TOOL WORKS, CINCINNATI, OHIO.

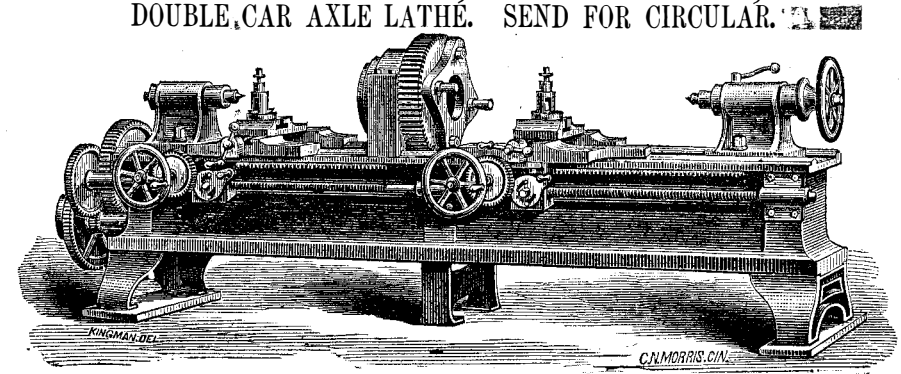

DOUBLE CAR AXLE LATHE. SEND FOR CIRCULAR.

PATENT BAND SAWING MACHINES

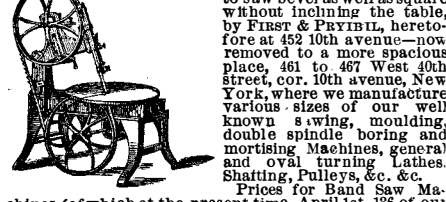

Of the most approved kinds to saw bevel as well as square without inclining the table, by FIRST & PRYBIL, heretofore at 452 10th avenue—now removed to a more spacious place, 461 to 467 West 40th street, cor. 10th avenue, New York, where we manufacture various sizes of our well known sawing, moulding, double spindle boring and mortising Machines, general and oval turning Lathes, Shaping, Pulleys, &c. &c. Prices for Band Saw Machines (of which at the present time, April 1st, 1872, of our make operate in New York City alone), are \$250, \$375, \$500, and \$400. To the largest a feed can be attached to resist boards. A machine to resist heavy timber is in construction. Have on hand a large stock of best French Band Saw Blades.

Damper Reg. Pat. Gage Cocks. Water Feed Reg's. Send for circulars. MURRILL & KRIZER, Balt., Md.

LAVERACK COLLEGE & Hud'n Riv. Inst., Claverack, N. Y. Rev. ALONZO FLACK, A. M., Pres't. Term opens Sept. 9. 10 Departments. 18 Instructors. DEDUCTION to gentlemen and ladies in Normal class.

Over 12,000,000 square feet now in use.



ASBESTOS ROOFING

FIRST PREMIUM (MEDAL) AWARDED IN 1870, AND INDORSED BY CERTIFICATE FROM THE AMERICAN INSTITUTE IN 1871, AS THE BEST ARTICLE IN THE MARKET. The "Asbestos Roofing" is a substantial and reliable material, which can be safely used in place of Tin, Slate, etc., on steep or flat roofs, in all climates, and can be easily and cheaply transported and applied. It is finished on the roof with the "Asbestos Roof Containing," prepared ready for use. (Also valuable for restoring old Tin, Shingle and other roof.) Also, manufacturer of ASBESTOS BOILER FELTING, Roofing and Sheathing Felts, Fire, Water and Acid-proof Compositions, Paints, &c., and dealer in "ASBESTOS, ASPHALTUM," &c. ASBESTOS BOARD, an entirely new article, for covering Locomotive Boilers, Marine Engines, Hot Air Pipes, &c., and for flat Packing for "Man Hole Plates," Gaskets, &c., on Boilers, Oil Stills, &c. In sheets 30x40 inches, from 1-16 to 1/2 inches thick. Also, ASBESTOS PAPER for Linings, etc. Send for Descriptive Pamphlets, Price Lists, Terms to Dealers, etc. H. W. JOHNS, 78 William St., New York.

TO PATENT RIGHT DEALERS—Harris Boardman's celebrated Patent Right on Cork Cutting Machines is now offered for sale at a big gain. These Machines are now in successful operation in Boston, Philadelphia, Lancaster, Pittsburgh, &c. Address Lancaster, Pa., Aug., 1872. SA RAH A. BOARDMAN.

THE TANITE CO.'S GOODS are kept in Stock, and sold at Factory Prices, by CHAMPLIN & ROGERS, 214 1/2 East Madison St., Chicago, who are also Exclusive Western Agents for the New York Tap and Die Co.'s goods, and Dealers in Railway, Mill, and Machinists' Supplies.

BEACH'S Scroll Sawing Machine, Improved, guaranteed the cheapest and best in use. Thirty days' trial given. Send for illustrated circular and price list. Address H. L. BEACH, 90 Fulton St., New York.

VENEERS AND HARDWOOD LUMBER.

BUTTERNUT, FRENCH AND AMERICAN WALNUT, ASH AND CHERRY BURL, HUNGARIAN ASH, BIRDSEYE & BLISTER MAPLE, etc. etc. Mahogany, Rosewood, Cedar, etc., in boards, plank, and logs. Large and choice stock at low prices. GEORGE W. READ & CO., 170 & 172 Center St., New York. Mill and Yard, 186 to 200 Lewis, bet. 5th & 6th Sts. E. R. Send for Catalogues and Price List.

The Union Stone Co.,

Patentees and Manufacturers of EMERY WHEELS & EMERY BLOCKS, In Size and Form to Suit various Mechanical Uses; GRINDERS, SAW GUMMERS, DIAMOND TOOLS, and WOOD'S PATENT KNIFE-GRINDER, For Planing, Paper Cutting, Leather Splitting, and other Long Knives. OFFICE, 29 KILBY STREET, Boston, Mass. BRANCH OFFICES, 133 Liberty Street, New York, 502 Commerce Street, Philadelphia. Send for circular.

PAT. SOLID EMERY WHEELS AND OIL STONES, for Brass and Iron Work, Saw Mills, and Edge Tools. Northampton Emery Wheel Co. Leeds, Mass.

The Wheat Field of America!

Healthful Climate, Free Homes, Good Markets.

THE NORTHERN PACIFIC RAILROAD offers for sale its Lands in Central and Western Minnesota, embracing: 1. The best of Wheat Land; 2. Excellent Timber for the Mill, the Farm, and the Fire; 3. Rich Prairie Pasturage and Natural Meadow, watered by clear Lakes and running streams—in a Healthful Climate, where Fever and Ague is unknown.

Grain can be shipped hence by lake to market as cheaply as from Eastern Iowa or Central Illinois. Cars now run through these Lands from Lake Superior to Dakota. Price of land close to track \$4.00 to \$8.00 per acre; further away, \$2.50 to \$4.00. Seven Years' Credit; Warrantee Deeds; Northern Pacific 7-30 Bonds, now selling at par, received for land at \$1.10. No other unoccupied Lands present such advantages to settlers.

SOLDIERS under the New Law (March, 1872) get 160 acres FREE near the railroad, by one and two years' residence.

TRANSPORTATION AT REDUCED RATES furnished from all principal points East to purchasers of Railroad Lands, and to Settlers on Government Homesteads. Purchasers, their wives and children, carried free over the Northern Pacific Road. Now is the time for Settlers and Colonies to get Railroad Lands and Government Homesteads close to the track.

Send for Pamphlet containing full information, map and copy of New Homestead Law. Address: LAND DEPARTMENT, NORTHERN PACIFIC RAILROAD, ST. PAUL, MINN., COR 23 FIFTH AVENUE, Cor. 9TH ST., NEW YORK.

PORTLAND CEMENT,

OF the well known manufacture of John Bazley White & Brothers, London, for sale by JAMES BRAND, 55 Cliff St., N. Y.

Working Models

And Experimental Machinery, Metal, or Wood, made to order by J. F. WERNER, 62 Center St., N. Y.

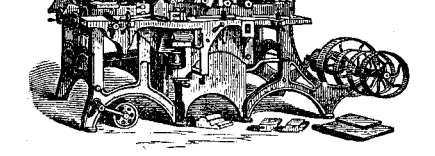

Universal Wood Worker. Horizontal and Upright Boring Machines. Superior for any in use. MCBETH, BENIEL & MARGEDANT, Hamilton, Ohio.

IRON PLANERS, ENGINE LATHES, Drills, and other Machinists' Tools, of superior quality, on hand, and finishing. For sale low. For Description and Price address NEW HAVEN MANUFACTURING CO. New Haven, Conn.

HOW TO SELL PATENTS.

Send for our explanatory circular, free by mail to any address. E. E. ROBERTS & CO., Consulting Engineers, 15 Wall St. New York.

T. V. Carpenter, Advertising Agent. Address Box 775, New York city.

A. S. CAMERON & CO., ENGINEERS,



Works, foot of East 23d street, New York city. Steam Pumps, Adapted to every possible duty. Send for a Price List.

Diamond-Pointed STEAM DRILLS.

THE adoption of new and improved applications to the celebrated Leschot's patent, have made these drills more fully adaptable to every variety of ROCK DRILLING. Their unequalled efficiency and economy are acknowledged, both in this country and Europe. The Drills are built of various sizes and patterns; WITH AND WITHOUT BOILERS, and bore at a uniform rate, of THREE TO FIVE INCHES PER MINUTE in hard rock. They are adapted to CHANNELLING, GADDERING, SHAPING, TUNNELLING, and open cut work; also, to DEEP BORING FOR TESTING THE VALUE OF MINES AND QUARRIES. TEST CORES taken out, showing the character of mines at any depth. Used either with steam or compressed air. Simple and durable in construction. Never need sharpening. Manufactured by THE AMERICAN DIAMOND DRILL CO., No. 61 Liberty St., New York.

KIDDER'S PASTILES—A Sure Relief for Asthma. STOWELL & CO., Charlestown, Mass.

LUBRICATORS. DREYFUS' celebrated Self-acting Oilers, for all sorts of Machinery and Shafting, are reliable in all seasons, saving 75-85 per cent. The Self-acting Lubricator for Cylinders is now adopted by over 80 R.R. in the U.S., and by hundreds of stationary engines. Send for a circular to NATHAN & DREYFUS, 108 Liberty St., N. Y.

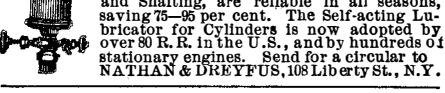

SCHLENKER'S PATENT BOLT CUTTER

NEW INVENTION. ADDRESS, HOWARD IRON WORKS, BUFFALO, N. Y.

THE BAND SAW!

Its ORIGIN and HISTORY, with Engravings of the OLDEST MACHINE, sent gratis. Address RICHARDS, LONDON & KELLEY, 22d St (above Arch), Philadelphia.

SAM'L S. FISHER, Cincinnati. SAM'L A. FISHER, New York. Wm. H. FISHER, natl. SAM'L A. DUNCAN, York. FISHER & DUNCAN, Counsellors at Law in Patent Cases including Interference and Extension Cases in the United States Courts. OFFICES: 8 West Third St., Cincinnati. 239 BROADWAY, New York.

American Saw Co.

No. 1 Ferry Street, corner Gold Street, New York, MANUFACTURERS OF Patent Movable-Toothed CIRCULAR SAWS, Patent Perforated Circular, Mill, AND Cross-cut Saws. Send for Descriptive Pamphlet.



GEORGE PAGE & CO., Manufacturers of Portable and Stationary STEAM ENGINES AND BOILERS; Patent Circular, Gang, Mulay, and Sash SAW MILLS, with OUTFITS COMPLETE, combining all reliable improvements—Grist Mills; Shingle Machines; Wood Working and General Machinery. Send for Descriptive Catalogues. Address No. 5 W. Schroeder Street, Baltimore Md.

FLOURING MILL, near ST. LOUIS MO, FOR SALE.

In Belleville, Ills., now of the suburbs of St. Louis—a first class Steam Flouring Mill, with four run of burrs, capable of turning out over 400 bbls. of flour in 24 hours. The crop this year, now harvested, is one of the best in many years, and wheat already rules low. This season the Milling business in this section was very remunerative, and it promises equally well for the present. Liberal terms can be given. Address IMBS, MEYER & FUSZ, St. Louis, Mo.

IRON STEAMSHIP BUILDERS. NEAFIE & LEVY, PENN WORKS,

MARINE ENGINES, BOILERS, AND BUILDERS OF COMPOUND ENGINES, PHILADELPHIA PA.

TODD & RAFFERTY, Manufacturers of Steam Engines, Boilers, Flax Hemp, Tow Bagging, Rope and Oakum Machinery, Steam Pumps and Governors, always on hand. Also Agents for the New Haven Manufacturing Co.'s Machinists' Tools. We invite especial attention to our new, improved, Portable Steam Engines. Warerooms, 10 Barclay St. Works Paterson, N. J.

LATHE CHUCKS—HORTON'S PATENT from 4 to 36 inches. Also for car wheels. Address R. HORTON & SON, Windsor Locks, Conn.

MORRIS, TASKER & CO., MANUFACTURERS OF

American Charcoal Iron Boiler Tubes.

Wrought-Iron Tubes and Fittings, FOR GAS, STEAM, WATER AND OIL. Steam and Gas Fitters' Supplies, Machinery for Coal Gas Works, &c. &c. NO. 15 GOLD ST., NEW YORK.

ASBESTOS GROUND, short and long fibres, sold in all quantities by L. & J. W. FEUCHTWANGER, 55 Cedar St., New York.

THE "Scientific American" is printed with CHAS. ENUV JOHNSON & CO.'S INK. Tenth and Lombard sts. Philadelphia and 59 Gold st. New York.