

REFRIGERATION
COLD STORAGE AND
ICE-MAKING



A.J. Wallis-Taylor C.E.

Refrigerating and

Ice- Machinery

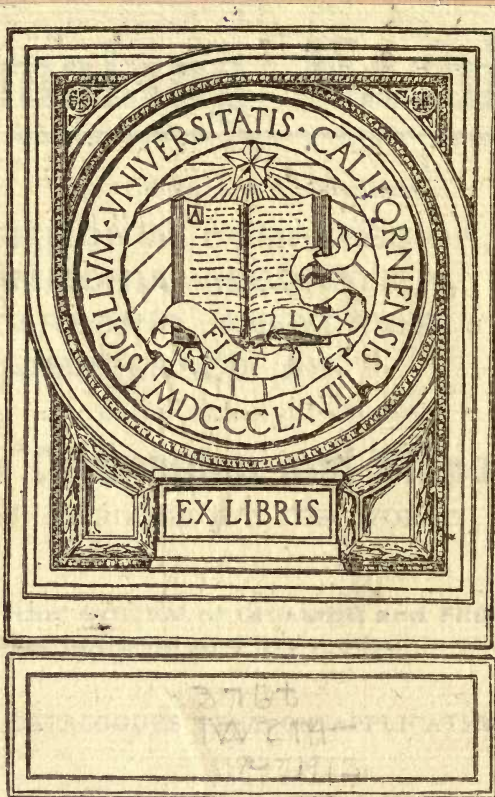

Mea

wners

HASLAM'S
the

ZING MEAT,
tence.

Makers of GAS ENGINES, 100 to 2000 B.H.P.

The Haslam Foundry & Engineering Co. Ltd.

(INCORPORATED WITH PONTIFEX & WOOD, Ltd.),

UNION FOUNDRY, DERBY,

And 175 to 177 SALISBURY HOUSE, LONDON, E.C.

Telegraphic Address—
"ZERO, DERBY."



Telephone No. 778 Derby.
A B C and Bentley's Codes used.

CARBONIC ANHYDRIDE & AMMONIA
REFRIGERATING
MACHINERY

USED BY

BRITISH & FOREIGN GOVERNMENTS, AND
ALL LEADING STEAMSHIP COMPANIES
THROUGHOUT THE WORLD.

ALSO BY

COLD STORAGE AND ICE-MAKING COMPANIES,
MEAT FREEZING WORKS, BREWERIES, PUBLIC
INSTITUTIONS, DAIRIES, &c. &c.

Full information furnished by

J. & E. HALL LTD.,
10 St Swithin's Lane, London, E.C.
And Dartford Ironworks, Kent.

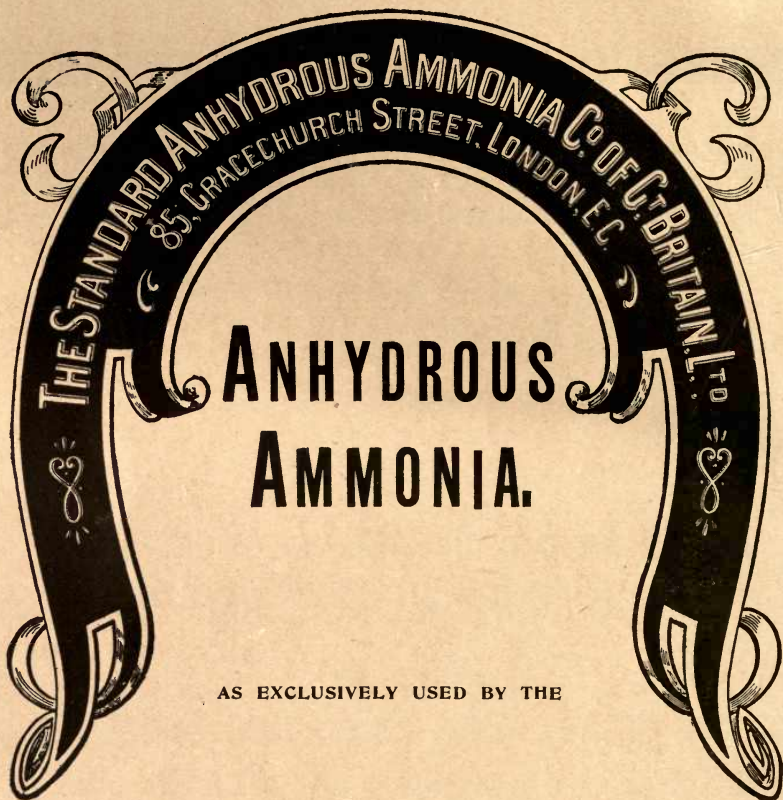

AS EXCLUSIVELY USED BY THE

LARGEST CONSUMERS

IN

THE UNITED KINGDOM.

SUPPLIERS TO THE ADMIRALTY.

MAXIMUM EFFICIENCY, MINIMUM COST.

IMMEDIATE DELIVERY.

Telegrams :
"ANHYDROUS, LONDON."

Telephone No., 1729 AVENUE.
(3 Lines.)

W.C.W.

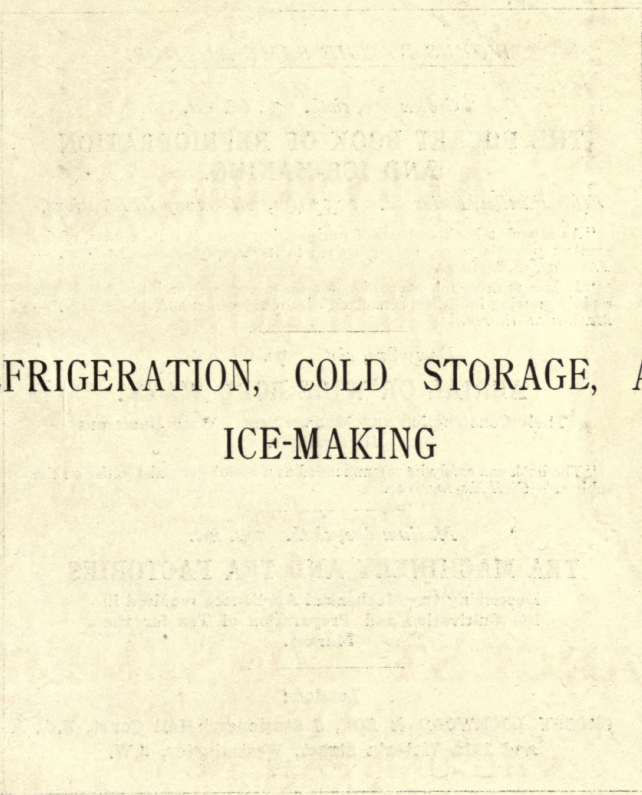

REFRIGERATION, COLD STORAGE, AND ICE-MAKING

WORKS BY THE SAME AUTHOR.

Crown 8vo, cloth. 3s. 6d. net.

**THE POCKET BOOK OF REFRIGERATION
AND ICE-MAKING.**

Fifth Edition, Enlarged. 205 pages, with many Illustrations.

"As a pocket book to users of refrigerating plant it is, of course, of the greatest possible value, having regard to its comprehensive character."—*The Marine Engineer.*

"It is a most useful companion for those engaged or interested in the rapidly growing industries connected with refrigeration and cold storage."—*Mechanical World.*

Demy 8vo, cloth. 7s. 6d. net.

AERIAL OR WIRE-ROPE WAYS:

**Their Construction and Management. With Numerous
Illustrations.**

"The book can safely be recommended as a useful general treatise on the subject."—*Civil Engineering.*

Medium 8vo, cloth. 25s. net.

TEA MACHINERY AND TEA FACTORIES

**Describing the Mechanical Appliances required in
the Cultivation and Preparation of Tea for the
Market.**

London:

**CROSBY LOCKWOOD & SON, 7 Stationers' Hall Court, E.C.,
and 121a Victoria Street, Westminster, S.W.**

REFRIGERATION COLD STORAGE AND ICE-MAKING

*A PRACTICAL TREATISE
ON THE ART AND SCIENCE OF REFRIGERATION*

WITH WHICH IS INCORPORATED
“REFRIGERATING AND ICE-MAKING MACHINERY”
(THIRD EDITION)

BY

A. J. WALLIS-TAYLER, C.E.

ASSOC. M. INST. C.E.

AUTHOR OF “REFRIGERATING AND ICE-MAKING MACHINERY,” “THE POCKET-BOOK OF
REFRIGERATION AND ICE-MAKING,” “SUGAR MACHINERY,” “TEA MACHINERY,”
“BEARINGS AND LUBRICATION,” “AERIAL OR WIRE ROPE TRAMWAYS,”
“MOTOR VEHICLES FOR BUSINESS PURPOSES,”
ETC., ETC.

Third Edition, thoroughly Revised

WITH FOUR HUNDRED AND FOURTEEN ILLUSTRATIONS



LONDON
CROSBY LOCKWOOD AND SON
7 STATIONERS' HALL COURT, LUDGATE HILL
AND 121A VICTORIA STREET, S.W.

1912

REFRIGERATION
COLD STORAGE AND
ICE-MAKING

TP492
W32
1912

A. J. WALLIS-TAYLER, C.E., A.M.I.C.E.,
"ESQUIMALT,"

ROBIN HOOD LANE,
SUTTON, SURREY.

Inspections, Surveys, Tests, Reports, Expert Evidence, Working
and other Drawings, Technical Translations from or into French,
&c. &c.

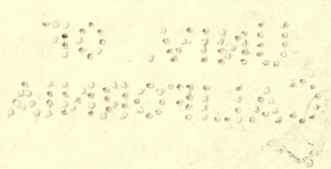

LONDON
ORRBY LOCKWOOD AND SON
15, ABINGDON ROAD, SOUTH KENSINGTON, LONDON, S.W. 7

PREFACE

THE preservation of comestibles collected during times of plenty, for uses when the sources of supply fail, has been practised by man from the remotest ages and in the most uncivilised regions. Amongst primitive races, in order to avoid famine the preservation of food for use during certain times of the year was absolutely essential, and in civilised countries it is a factor mainly responsible for the maintenance of the balance between the demand and the supply.

Probably the most ancient method employed for the preservation of food stuffs is desiccation or drying, and it is an excellent one, meat, for instance, so treated loses none of its nutritive qualities as it undergoes no chemical change. The remaining methods used are heating and sealing in air-tight packages, treatment by means of chemicals, and refrigeration.

The conservation of meat and other food stuffs by the latter method, which is now so extensively used, is that with which the author is here solely concerned. By means of refrigeration or thermal control meat can now be transported round the world whilst retaining its original freshness. And fish, milk, butter, eggs, and fruits of almost every variety can also be preserved and transported in good condition. In fact, as stated in the Preface to the first edition of this book, refrigeration is a subject of great and daily increasing interest, and the field of usefulness of the art is continually widening. When the author produced, in 1895, his smaller work entitled "Refrigerating and Ice-Making Machinery," the literature dealing specifically with the subject was of a very limited, and chiefly of a scattered description, but at the present time there are a number of books published, and the periodical literature has also been largely augmented.

The success attained by "Refrigerating and Ice-Making Machinery" encouraged the production of the present larger volume, with the second edition of which was incorporated the third edition of the above-mentioned smaller book.

In this, the third edition of the larger volume, an additional chapter dealing with dairy refrigeration has been added, the introductory chapter has been partly re-written and brought up to date, as have also been those chapters dealing with examples of modern refrigerating machinery, marine refrigeration, manufacturing industrial and constructional applications, ice-making, and the management and testing of refrigerating machinery. A large number of the illustrations contained in the previous editions have been replaced by blocks of more modern machines, and forty-six entirely new engravings have been added. The author takes this opportunity, moreover, of acknowledging the valuable assistance rendered by Mr G. J. Wells, W.Sc., A.M.I.C.E., in revising the chapter devoted to the theory of refrigeration.

Those requiring in a very concise form the primary details regarding ice-making and refrigerating machinery, cold storage, insulation, &c., will find their wants supplied by the fifth edition of "The Pocket Book of Refrigeration and Ice-Making," by the same author, and as this little volume comprises in addition to the above a very considerable number of important tables and other useful memoranda, conveniently arranged for immediate reference, it forms also a valuable companion to the larger book.

A. J. WALLIS-TAYLER.

SUTTON, *December* 1911.

CONTENTS

CHAPTER I.

INTRODUCTION.

| | PAGE |
|--|------|
| Origin of Artificial Refrigeration—History and Progress of the Trade in Fresh Provisions | 1-7 |

CHAPTER II.

THE THEORY AND PRACTICE OF MECHANICAL REFRIGERATION.

| | |
|---|------|
| Relation to First Two Laws of Thermo-dynamics—Definition of Heat—Specific Heat—Latent Heat—Mechanical Equivalent of Heat—Calculations made with respect to Heat—Temperature—Laws of Gases—Construction of Chart Applicable to any Value of n —Work Demanded of a Refrigerating Machine—Greatest Theoretical Efficiency of a Refrigerating Machine | 8-20 |
|---|------|

CHAPTER III.

THE LIQUEFACTION PROCESS.

| | |
|--|-------|
| Use of, by the Ancients—Various Machines Operating on the—General Laws Governing Production of Cold by—Principal Freezing Mixtures | 21-24 |
|--|-------|

CHAPTER IV.

THE VACUUM PROCESS.

| | |
|---|-------|
| Principles of—First Machine working on—More Recent Types of Machines Working on | 25-33 |
|---|-------|

CHAPTER V.

THE COMPRESSION PROCESS OR SYSTEM.

| | |
|---|-------|
| Early History of—Principles of—Cycle of Operations Obligatory in—Improvements in—Ether Machines—Sulphurous Acid Machines—Carbonic Acid Machines | 34-47 |
|---|-------|

CHAPTER VI.

THE COMPRESSION PROCESS (continued).

| | |
|--|--------|
| Ammonia Machines—Properties of Ammonia—Cycle of Operations—Wet and Dry Compression Principle—Construction of Gas Compressors—Various Examples of Modern Machines | 48-116 |
|--|--------|

CHAPTER VII.

THE COMPRESSION PROCESS (continued).

| | PAGES |
|--|---------|
| Properties of Ether—Modern Ether Machines—Properties of Methyl-Chloride—Methyl-Chloride Machines—Properties of Sulphurous Acid—Sulphurous Acid Machines—Properties of Carbonic Acid—Carbonic Acid Machines | 117-151 |

CHAPTER VIII.

CONDENSERS AND WATER COOLING AND SAVING APPARATUS.

| | |
|--|---------|
| Submerged Condensers—Amount of Cooling Water required—Atmospheric or Open-air Evaporative Surface Condensers—Amount of Condenser Surface required—Amount of Cooling Water required—Supplementary Condensers or Forecoolers—Double-pipe Condensers—Hendrick's Condenser—Water-cooling and Saving Apparatus—Water-cooling Towers | 152-173 |
|--|---------|

CHAPTER IX.

THE ABSORPTION AND BINARY ABSORPTION PROCESS OR SYSTEM.

| | |
|--|---------|
| The Principle of the Absorption Process—Early Machines—Later Patterns of Machines—The Binary Absorption Process, or Machines Using a Compound or Dual Liquid | 174-210 |
|--|---------|

CHAPTER X.

THE COLD-AIR SYSTEM.

| | |
|---|---------|
| Principles of—Early Machines—Modern Patterns of Machines—The Allen Dense-Air Ice Machine—Maximum Theoretical Efficiency of Cold-Air Machines—Comparative Tests of Cold-Air Machines | 211-245 |
|---|---------|

CHAPTER XI.

COCKS, VALVES, AND PIPE JOINTS AND UNIONS.

| | |
|--|---------|
| Expansion or Regulating Cocks and Valves—Stop-Cocks and Valves—Suction and Discharge Valves—Pipe Joints and Unions—Means for Increasing the Cooling Surface of Pipes | 246-269 |
|--|---------|

CHAPTER XII.

REFRIGERATION AND COLD STORAGE.

| | |
|---|---------|
| Refrigeration by means of the Cold-Air Machine—Refrigeration by means of Compression or Absorption Machines—The Brine Circulation System—The Direct Expansion System—The Cold-Air Blast System—Piping for Cold Stores | 270-284 |
|---|---------|

CONTENTS.

ix

CHAPTER XIII.

REFRIGERATION AND COLD STORAGE (continued).

PAGES

| | |
|---|---------|
| The Construction and Arrangement of Cold Stores and of Cold Storage Rooms or Chambers—Ventilation—Air Circulation—Insulation—Railway Vans - | 285-371 |
|---|---------|

CHAPTER XIV.

REFRIGERATION AND COLD STORAGE (continued).

| | |
|--|---------|
| Hoisting and Conveying Machinery - | 372-380 |
|--|---------|

CHAPTER XV.

REFRIGERATION AND COLD STORAGE (continued).

| | |
|---|---------|
| Proper Methods of Storing, and Temperatures for the Cold Storage of Various Articles—Specific Heat and Composition of Victuals—Meat and Fish—Butter—Cheese—Milk—Eggs—Fruits—Vegetables—Morgues or Mortuaries—Table of Temperatures for Cold Storage of Various Articles - | 381-395 |
|---|---------|

CHAPTER XVI.

MARINE REFRIGERATION.

| | |
|---|---------|
| Carbonic Acid Machines—Ammonia Machines—Cold-Air Machines—Arrangement of Cargo Holds and Stores—Ice-making on Board Ship—Barges - | 396-421 |
|---|---------|

CHAPTER XVII.

REFRIGERATION IN DAIRIES.

| | |
|---|---------|
| Methods of Using Mechanical Refrigeration in Dairies—Examples of Mechanical Refrigerating Installations in Dairies—Milk or Cream Coolers—Ice-cooled Creamery Refrigerators—Air Circulation System—Cylinder System—Insulation of Dairy or Creamery Refrigerators—Sizes of Ice Chambers—General Particulars—Materials—Ice Refrigerating Machine - | 422-438 |
|---|---------|

CHAPTER XVIII.

MANUFACTURING, INDUSTRIAL AND CONSTRUCTIONAL APPLICATIONS.

| | |
|---|---------|
| Chocolate Manufacture—Breweries—Paraffin Works—Artificial Butter Manufactories—Tea Factories—Sugar Factories and Refineries—Blast Furnaces—Wine Making—Various other Manufacturing and Industrial Applications—Dynamite Factories—Manufactories of Photographic Accessories—Distilleries—Chemical Works—India-rubber Works—Glue Works—Constructional Applications: Tunneling, Sinking Shafts, Laying Foundations, &c. - | 439-483 |
|---|---------|

CONTENTS.

CHAPTER XIX.

ICE-MAKING.

| | PAGES |
|---|---------|
| Various Methods of Ice-Making—The Can System—The Wall or Plate System—The Stationary Cell System—Miscellaneous Arrangements for Making Clear or Crystal Ice by Agitation—Holden System of Ice-Making—Water De-aerating or Distilling Apparatus—Vacuum System of Ice-Making—Imitation of Natural System—Ice Factories—Ice Elevating and Conveying Machinery—Ice-Making, General—Brine—Storing Ice—Ice-Crushing or Breaking Machinery | 484-538 |

CHAPTER XX.

THE MANAGEMENT AND TESTING OF REFRIGERATING MACHINERY, ETC.

| | |
|---|---------|
| Management—Ammonia Compression Machines—Oil Separators or Collectors—Accumulations of Deposit in the Condenser—Breaking Joints—Lubricating Qualities of Ammonia—Compressor Piston-rod packings—To Charge and Work a Carbonic Acid Machine—Freezing or Choking up of Compression System—Lubrication of Refrigerating Machinery—Leaks in Ammonia Apparatus—Leaks in Carbonic Acid Machines—Effect of a Coating of Ice on Direct Expansion Pipes—Defrosting Refrigerating Coils—Incrustation on Condenser Coils—Cold-Air Machines—Testing—Interpretation of Compressor Diagrams—Absorption Machines—Amount of Water required in Refrigerating Apparatus—Determination of Moisture in Air—Psychrometers—Hygrometers—Electrical Temperature Tell-tales and Long-distance Thermometers—The Thermograph—The Telethermometer or Electrical Thermometer—Lighting Cold Stores | 539-578 |
|---|---------|

CHAPTER XXI.

COST OF WORKING.

| | |
|---|---------|
| Main Items of Expense—Absorption Machines—Compression Machines—Vacuum Machines—Cold-Air Machines—Cost of Ice-Making | 579-587 |
|---|---------|

CHAPTER XXII.

THE PRODUCTION OF VERY LOW TEMPERATURES.

| | |
|---|---------|
| Early Investigators and Experimenters—The Cascade System—The Regenerative Method—Properties of Liquid Air—Physical Constants of Liquefied Gases | 588-601 |
|---|---------|

APPENDIX.

BIBLIOGRAPHY OF REFRIGERATION.

| | |
|-------------------|---------|
| Books—Periodicals | 602-604 |
| INDEX | 605-632 |

LIST OF ILLUSTRATIONS

| FIG. | PAGE |
|--|------|
| 1. Diagram showing Method of Constructing Curve $PV^n = C$ - - - | 13 |
| 2. Diagram showing Method of Constructing Curve $PV^n = C$ - - - | 14 |
| 3. Diagram showing Method of Constructing Chart - - - | 15 |
| 4. Carré's Sulphuric Acid Vacuum Freezing Machine - - - | 26 |
| 5. Langé's Exhaust Pump for Vacuum Freezing Machine - - - | 29 |
| 6. Harrison's Rotating Exhaust Pump or Cylinder - - - | 30 |
| 7. Perkins' Early Type of Compression Machine - - - | 35 |
| 8. Diagram Illustrating the Operation of a Refrigerating Machine on the Compression Principle - - - - - | 37 |
| 9. Harrison's Ether Compression Machine - - - - - | 38 |
| 10. Tellier's Apparatus for the Distillation of Methylic Ether - - - | 41 |
| 11. Tellier's Methylic Ether Compression Machine - - - - - | 41 |
| 12. Expansion Valve or Distributor of Tellier's Methylic Ether Machine | 42 |
| 13. Original Type of Windhausen Compressor with Liquid Piston for Treating the Gas in Two Stages - - - - - | 46 |
| 14. Suction Valve of Windhausen Compressor for Treating Gas in Two Stages - - - - - | 47 |
| 15. Outlet or Discharge Valve of Windhausen Compressor for Treating Gas in Two Stages - - - - - | 47 |
| 16. Diagram Illustrating Loss Due to Clearance Space in Compressor Cylinder - - - - - | 54 |
| 17. Double-acting Vertical Type De La Vergne Ammonia Compressor. Vertical Section through Compression Cylinder - - - - - | 58 |
| 18. Double-acting Vertical Type De La Vergne Ammonia Compressor. Side Elevation of Complete Machine - - - - - | 59 |
| 19. Diagrammatical View showing Complete Installation of a Refrigerat- ing Plant on the De La Vergne Ammonia Compression System | 60 |
| 20. Diagram taken from Single-acting De La Vergne Ammonia Com- pressor without Sealing, Lubricating, and Cooling Fluid - - - | 62 |
| 21. Diagram taken from Single-acting De La Vergne Ammonia Com- pressor with Sealing, Lubricating, and Cooling Fluid - - - | 63 |
| 22. Diagram taken from Double-acting De La Vergne Ammonia Com- pressor with Sealing, Lubricating, and Cooling Fluid - - - | 64 |
| 23. Horizontal Type of Belt-driven Sterne Ammonia Compressor - - - | 65 |
| 24. Small Single-acting Vertical Type Frick Ammonia Compressor. Vertical Central Section through Cylinder - - - - - | 67 |

| FIG. | PAGE |
|---|------|
| 25. Large Single-acting Vertical Type Frick Ammonia Compressor. Vertical Central Section through Cylinder - - - | 68 |
| 26. Large Single-acting Vertical Type Frick Ammonia Compressor. Sectional Elevation of Complete Machine - - - | 69 |
| 27-32. Diagrams taken from Frick Compressor - - - | 70 |
| 33. Enock's Patent Safety Compressor. Vertical Section - - - | 72 |
| 34. Enock Safety Crossheads and Springs - - - | 73 |
| 35. Enock Patent Compressor. Inclosed Type, with Coupled Vertical Steam Engine - - - | 74 |
| 36. 20-ton Open Type of Ammonia Compressor; Fitted with Enock's Patent Safety Crosshead - - - | 75 |
| 37. Enock Inclosed Type 65-ton Compressor - - - | 77 |
| 38. Enock Self-oiling Midget Type Compressor - - - | 78 |
| 39. Linde Horizontal Type of Compound Ammonia Compressor. Plan View - - - | 79 |
| 40. American Pattern Linde Horizontal Type of Ammonia Compressor. Part Sectional View - - - | 81 |
| 41. Horizontal Type of Belt-driven Humboldt Ammonia Compressor - - | 82 |
| 42. Two-Cylinder Single-acting Fixary Compressor - - - | 84 |
| 43. Double-acting Ammonia Compressor, Pulsometer Engineering Co., Ltd. | 86 |
| 44. Small Single-acting Kilbourn Inclosed Type Ammonia Compressor and Condenser - - - | 88 |
| 45. Double-acting Horizontal Type Triumph Ammonia Compressor. Sectional View - - - | 89 |
| 46. Double-acting Horizontal Type Triumph Ammonia Compressor and Tandem Compound Condensing Engine. Plan View - - | 90 |
| 47. Double-acting Puplett Ammonia Compression Machine - - - | 92 |
| 48. Horizontal Type Compound Haslam Ammonia Compressor. Vertical Central Section - - - | 93 |
| 49. Horizontal Type of Haslam Double-acting Ammonia Compressor with Compound Drop-Valve Engine - - - | 95 |
| 50. Horizontal Type of Haslam Double-acting Ammonia Compressors with Compound Steam-Engine - - - | 96 |
| 51. Horizontal Compound Type of Haslam Ammonia Compressor with Compound "Drop-Valve" Steam-engine - - - | 98 |
| 52. Single-acting Vertical Type Ammonia Compressor, York Manu- facturing Co. Sectional Elevation of Complete Machine - - | 100 |
| 53. Horizontal Type of Belt-driven Tuxen and Hammerich Ammonia Compressor - - - | 101 |
| 54. Vertical Type of Steam-driven Buffalo Ammonia Compressor. Vertical Central Section through Cylinder - - - | 103 |
| 55. Vertical Type of Steam-driven Hercules Ammonia Compressor. Vertical Central Section through Cylinder - - - | 107 |
| 56. Double-acting Horizontal Type Barber Steam-driven Ammonia Com- pressor - - - | 109 |
| 57. Double-acting Horizontal Type Barber Electrically-driven Ammonia Compressor - - - | 110 |
| 58. Small Single-acting Horizontal Type Barber Steam-driven Ammonia Compressor - - - | 111 |

LIST OF ILLUSTRATIONS.

xiii

| FIG. | PAGE |
|---|------|
| 59. Double-acting Horizontal Type Vulcan Ammonia Compressor. Central Section through Cylinder - - - - - | 112 |
| 60. Small Single-acting Vertical Inclosed Type Vulcan Ammonia Compressor. Elevation partly in Vertical Section - - - - - | 113 |
| 61. Small Single-acting Vertical Inclosed Type Vulcan Ammonia Compressor. Transverse Section - - - - - | 114 |
| 62. Belt-driven Horizontal Type West Ether Compression Machine - - - - - | 118 |
| 63. Single-acting Inclosed Type Douane Methyl Chloride Compressor. Vertical Central Section - - - - - | 121 |
| 64. Belt-driven Double-acting Vertical Type Quiri Sulphurous Acid Compression Machine - - - - - | 122 |
| 65. Belt-driven Double-acting Horizontal Type Quiri Sulphurous Acid Compressor - - - - - | 123 |
| 66. Belt-driven Horizontal Inclosed Type Douglas-Conroy Sulphurous Acid Compression Machine. Elevation partly in Vertical Section - - - - - | 125 |
| 67. Belt-driven Horizontal Inclosed Type Douglas-Conroy Sulphurous Acid Compression Machine. Plan of Compressor - - - - - | 126 |
| 68. Belt-driven Horizontal Inclosed Type Douglas-Conroy Sulphurous Acid Compression Machine. Section on line A-B, Fig. 67 - - - - - | 127 |
| 69. Belt-driven Horizontal Inclosed Type Douglas-Conroy Sulphurous Acid Compression Machine. Section on line C-D, Fig. 67 - - - - - | 128 |
| 70. Vertical Type of Belt-driven Humboldt Sulphurous Acid Compression Machine - - - - - | 130 |
| 71. Belt-driven Vertical Type Hall Carbonic Acid Compression Machine - - - - - | 131 |
| 72. Belt-driven Vertical Type Hall Carbonic Acid Compression Machine. Sectional View - - - - - | 132 |
| 73. Belt-driven Vertical Type Hall Carbonic Acid Compression Machine. Cross Section through Cylinder - - - - - | 133 |
| 74. Belt-driven Vertical Type Hall Carbonic Acid Compression Machine. Vertical Central Section through Cylinder - - - - - | 133 |
| 75. Belt-driven Vertical Type Hall Carbonic Acid Compression Machine. Vertical Section through Spiral Packing Ring - - - - - | 134 |
| 76. Belt-driven Vertical Type Hall Carbonic Acid Compression Machine. Vertical Central Section through Suction Passage - - - - - | 135 |
| 77. Belt-driven Vertical Type Hall Carbonic Acid Compression Machine. Vertical Central Section through Safety Valve - - - - - | 135 |
| 78. Horizontal Type of Steam-driven Hall Carbonic Acid Compressor - - - - - | 136 |
| 79. Horizontal Type of Duplex Steam-driven Hall Carbonic Acid Compressor - - - - - | 137 |
| 80. Vertical Type of Belt-driven Hall Carbonic Acid Compressor. Most Recent Pattern - - - - - | 139 |
| 81. Horizontal Type of Belt-driven Hall Carbonic Acid Compressor. Most Recent Pattern - - - - - | 140 |
| 82. Vertical Type Steam-driven West Carbonic Acid Compression Machine - - - - - | 141 |
| 83. Vertical Type West Carbonic Acid Compression Machine. Vertical Central Section through Compressor Cylinder - - - - - | 142 |

| FIG. | PAGE |
|--|------|
| 84. Vertical Type West Carbonic Acid Compression Machine. Vertical Central Section through Valve. Enlarged Scale - - - | 143 |
| 85. Vertical Type Belt-driven Kroeschell Carbonic Acid Compression Machine - - - - - | 145 |
| 86. Horizontal Type Belt-driven Kroeschell Carbonic Acid Compressor - | 147 |
| 87. Vertical Type of Belt-driven Humboldt Carbonic Acid Compressor - | 148 |
| 88. Large Duplex Horizontal Type of Haslam Carbonic Acid Compressor | 150 |
| 89. Chew's Patent Condenser, Submerged Type. Vertical Central Section - - - - - | 153 |
| 90. Schou's Patent Condenser - - - - - | 155 |
| 91. Diagram showing Simple Method of Distributing Water in Atmospheric Condenser - - - - - | 158 |
| 92. Diagram showing Objections to Common Plan of Distributing Water in Atmospheric Condensers - - - - - | 159 |
| 93. Diagram showing Method of Avoiding Spattering in Distributing Water in Atmospheric Condenser - - - - - | 159 |
| 94. Arrangement for Removing Liquefied Agent from Atmospheric Condenser - - - - - | 160 |
| 95. Haslam's Open-air Evaporative Surface Condenser - - - - - | 161 |
| 96. Haslam Interlaced Type of Ammonia Condenser - - - - - | 162 |
| 97. Triumph Atmospheric or Open-air Evaporative Surface Condenser - | 163 |
| 98. Rau's Atmospheric or Open-air Evaporative Surface Condenser - | 163 |
| 99, 100. Westerlin-Campbell Double-pipe Condenser. Side and End Elevations - - - - - | 166 |
| 101. Haslam Double-pipe Ammonia Condenser - - - - - | 167 |
| 102. Haslam Open Type of Water Cooler - - - - - | 169 |
| 103. Puplett's Water Saving and Cooling Apparatus - - - - - | 170 |
| 104. Triumph Water-Cooling Tower. Elevation - - - - - | 171 |
| 105. Haslam Water-Cooling Tower - - - - - | 172 |
| 106. Carré's Continuous-Acting Ammonia Absorption Machine - - - | 176 |
| 107. Pontifex-Wood Improved Continuous-Acting Ammonia Absorption Machine - - - - - | 188 |
| 108, 109. Pontifex-Wood Improved Ammonia Pump. Elevation and Vertical Central Section - - - - - | 189 |
| 110, 111. Hill's Ammonia Absorption Machine with Supplementary or Auxiliary Absorber. Diagrams showing Front and End Views - | 195 |
| 112. Hill's Ammonia Absorption Machine with Supplementary or Auxiliary Absorber. Diagrammatical View of Complete Machine - - - - - | 196 |
| 113. Tyler & Ellis' (Cracknell's Patent) Ammonia Absorption Machine. Front View - - - - - | 198 |
| 114. Tyler & Ellis' (Cracknell's Patent) Ammonia Absorption Machine. Side Elevation - - - - - | 199 |
| 115. Tyler & Ellis' (Cracknell's Patent) Ammonia Absorption Machine. Vertical Longitudinal Central Section - - - - - | 199 |
| 116. Lyon's Patent Ammonia Absorption Machine. Plan - - - - - | 200 |
| 117. Lyon's Patent Ammonia Absorption Machine. Front Elevation - | 201 |
| 118. Lyon's Patent Ammonia Absorption Machine. Vertical Longitudinal Section - - - - - | 202 |

LIST OF ILLUSTRATIONS.

xv

| FIG. | PAGE |
|---|------|
| 119. Senssenbrenner Patent Ammonia Absorption Machine | 203 |
| 120. Diagram Illustrating Coleman's Electrically-heated Absorption Machine | 203 |
| 121. Diagram Illustrating Leading Type of American Ammonia Absorption Machine | 206 |
| 122. Diagram showing Paths of Ammonia, Cooling Water, and Ammonia Liquor through Various Members of Absorption System | 207 |
| 123. Original Pattern Windhausen Cold-air Machine. Plan View | 217 |
| 124. Original Pattern Windhausen Cold-air Machine. Side Elevation | 218 |
| 125. Modified Form of Windhausen Cold-air Machine. Vertical Central Section | 220 |
| 126. Improved Type Giffard (1877) Cold-Air Machine. Sectional Side Elevation | 223 |
| 127. Haslam Cold-air Machine. Horizontal Pattern | 226 |
| 128. Haslam Cold-air Machine. Diagonal Pattern | 228 |
| 129. Haslam Cold-air Machine. Vertical Pattern | 229 |
| 130. Lightfoot Double-acting Cold-air Machine, Horizontal Pattern. Vertical Central Section | 232 |
| 131. Lightfoot Single-acting Cold-air Machine. Sectional Elevation | 233 |
| 132. Cole's "Arctic" Cold-air Machine with Auxiliary Cooling Arrangement. Sectional Elevation | 234 |
| 133. Cole's "Arctic" Cold-air Machine with Air-drying Arrangement. Small Size. Belt-driven Type | 235 |
| 134. Cole's "Arctic" Cold-air Machine with Air-drying Arrangement. Large Size. Steam-driven Type | 236 |
| 135, 136. Cole's "Arctic" Cold-air Machine with Air-drying Arrangement. Side Elevation partly in Section and Transverse Section | 237 |
| 137. Indicator Diagram from Double-acting Expander of Cole's "Arctic" Dry Cold-air Machine | 238 |
| 138. Indicator Diagram from Single-acting Expander of Cole's "Arctic" Dry Cold-air Machine | 238 |
| 139. Allen Dense-air Ice Machine. Diagrammatical View | 239 |
| 140. Taper Spindle Expansion or Regulating Valve. View partly in Vertical Section | 246 |
| 141. Taper Spindle Expansion or Regulating Valve. Vertical Central Section | 247 |
| 142. Triumph Angle Expansion or Regulating Valve. Vertical Central Section | 248 |
| 143. Triumph Globe Expansion or Regulating Valve. Vertical Central Section | 248 |
| 144. Frick Angle Expansion or Regulating Valve. Vertical Central Section | 249 |
| 145. De La Vergne Expansion or Regulating Cock. Vertical Central Section | 250 |
| 146. De La Vergne Expansion or Regulating Cock. View of Plug partly in Section | 250 |
| 147. De La Vergne Expansion or Regulating Cock. Plan | 250 |
| 148. Triumph Safety Combination Expansion Valve and Stop-Cock. Vertical Central Section | 251 |

| FIG. | PAGE |
|--|------|
| 149. Haslam Improved Type of Expansion Valve - - - - - | 251 |
| 150. De La Vergne 2½-in. Stop-cock. Vertical Central Section - - - | 252 |
| 151. De La Vergne 1-in. Stop-cock. Vertical Central Section - - - | 253 |
| 152. Frick Shut-off or Stop Valve. Vertical Central Section - - - | 254 |
| 153, 154. Frick Stop Valves. Perspective Views - - - - - | 254 |
| 155, 156. Haslam Standard Types of Ammonia Valves for Connections over 1 in. Diameter - - - - - | 255 |
| 157. Haslam Small Steel Valve for Gauge and other Connections under 1 in. Diameter - - - - - | 255 |
| 158. Discharge Valve, Hercules Compressor. Vertical Central Section - | 256 |
| 159. Suction Valve, Hercules Compressor. Vertical Central Section - | 256 |
| 160. Triumph Suction Valve. Vertical Central Section - - - - - | 257 |
| 161, 162. Triumph Pattern Suction Valves for Frick Compressor. Vertical Central Sections - - - - - | 258 |
| 163, 164. Triumph Pattern Suction Valves for De La Vergne Compressor. Vertical Central Sections - - - - - | 258 |
| 165. Triumph Pattern Valve for Calahan Compressor. Vertical Central Section - - - - - | 259 |
| 166. De La Vergne Pipe Joint. Perspective View - - - - - | 261 |
| 167. De La Vergne Pipe Joint. Vertical Central Section - - - - - | 262 |
| 168. Kilbourn Joint for Connecting Pipes to Plates. Vertical Central Section - - - - - | 263 |
| 169. Kilbourn Joint for Connecting Different Lengths of Pipe. Vertical Central Section through Joint - - - - - | 264 |
| 170. Flange Coupling or Union for Lead Gasket. Vertical Central Section | 265 |
| 171, 172. Frick Coupling or Union for Large Pipes. Vertical Central Section and End View - - - - - | 265 |
| 173. Frick Coupling or Union for Small Pipes. Vertical Central Section | 266 |
| 174. Flange Coupling or Union for Sheet Packing. Elevation partly in Vertical Central Section - - - - - | 266 |
| 175. De La Vergne Soldered Pipe Joint, Bend or Elbow. Vertical Central Section - - - - - | 266 |
| 176. Return Socket Bend. Vertical Central Section - - - - - | 266 |
| 177. Flange Bend or Elbow. Vertical Central Section - - - - - | 266 |
| 178, 179. Frick Evaporating Coil Bend. Side View partly in Section and End View - - - - - | 267 |
| 180, 181. Flange Return Bend. End View and Side View - - - - - | 267 |
| 182. Return Bend or Head Formed in Halves. Side Elevation - - - - - | 268 |
| 183. Return Bend or Head Formed in Halves. Vertical Central Section - - - - - | 268 |
| 184, 185. Discs or Gills for Increasing the Surface of Refrigerating Pipes. View showing Gill fixed on Pipe, and View showing One-half of Gill removed - - - - - | 268 |
| 186. Diagram showing the Variation in Capacity, &c., of a Refrigerating Machine - - - - - | 277 |
| 187. Arrangement of Cooling Pipes in Refrigerating Chamber. Trans- verse Section - - - - - | 289 |
| 188. Arrangement of Cooling Pipes in Ceiling Lofts. Transverse Sec- tion - - - - - | 290 |

LIST OF ILLUSTRATIONS.

xvii

| FIG. | PAGE |
|--|------|
| 189. Hill's Arrangement for Refrigerating Cold Rooms or Chambers. Diagrammatical View | 290 |
| 190. Hill's Arrangement for Refrigerating Cold Rooms or Chambers. Elevation of Chamber partly in Vertical Section | 291 |
| 191. Williamson's Patent Cold Storage Chamber | 293 |
| 192. Haslam's Patent Brine-Cooling Battery, for Cooling Air to be Circulated through Cold Storage Rooms. Plan View | 295 |
| 193. Douglas' Patent Apparatus for Cooling Air for Use in Cold Storage Rooms or Chambers. Vertical Central Section | 296 |
| 194. Cooper's Apparatus for Washing, Cooling, and Drying Air for Use in Cold Storage Rooms or Chambers. Diagrammatical View | 298 |
| 195. Arrangement of Cooling Pipes in Beef Chill-rooms Fitted with the De La Vergne Patent Pipe System. Transverse Section | 299 |
| 196. Beef Chill-room in Cold Store Fitted with Haslam Patent Brine- Cooling Battery. Transverse Section | 299 |
| 197. Refrigerating Installation on the Humboldt System Erected at Municipal Abattoir, Riga. Plan | 300 |
| 198. Refrigerating Installation on the Humboldt System Erected at Municipal Abattoir, Riga. Vertical Longitudinal Section | 301 |
| 199-201. Refrigerating Installation on the Humboldt System Erected at Municipal Abattoir, Riga. Transverse Sections | 302 |
| 202. Hog Chill-room Fitted with the De La Vergne Patent Pipe System. Transverse Section | 304 |
| 203. Arrangement of Cooling Pipes in Chill-room and Curing Cellar in Bacon Factory. Transverse Section | 305 |
| 204. Small Cold Store for Butchers, &c., Cooled by Cold-air Machine. Plan View | 307 |
| 205. Small Cold Store for Butchers, &c., Cooled by Ammonia Compression Machine. Sectional Elevation | 308 |
| 206. Small Cold Storage Room for Hotel or Private Residence. Vertical Section | 309 |
| 207. Cold Storage Rooms and Ice-Making Plant in Hotel. Perspective View | 310 |
| 208, 209. Rotating Air-Lock Door for Cold Storage Rooms in Hotels, &c. Sectional Elevation and Horizontal Section | 311 |
| 210. Diagram showing Gravity Air Circulation in Cold Storage Room or Chamber with Ceiling Piping | 314 |
| 211. Diagram showing Gravity Air Circulation in Cold Storage Room or Chamber with Side Wall Piping | 315 |
| 212. Diagram showing Gravity Air Circulation in Cold Storage Room or Chamber with Screened Wall Piping | 316 |
| 213. Diagram showing Gravity Air Circulation in Cold Storage Room or Chamber with Screened Wall Piping and Ceiling Extensions | 317 |
| 214. Diagram showing Gravity Air Circulation in Cold Storage Room or Chamber with Gay's Arrangement of Piping | 317 |
| 215. Diagram showing Gravity Air Circulation in Cold Storage Room or Chamber with St Clair Pipe Loft System | 318 |
| 216. Diagram showing Mechanical or Forced Air Circulation with Air Forced into the Room at Each End and Drawn Out at the Centre | 320 |

| FIG. | PAGE |
|--|------|
| 217. Diagram showing Mechanical or Forced Air Circulation with False Ceiling for Distributing Cold Air from the Coil-room - - - | 321 |
| 218. Diagram showing Mechanical or Forced Air Circulation with Air Admitted at Sides of Ceiling and Drawn Out at the Centre thereof | 322 |
| 219. Diagram showing Mechanical or Forced Air Circulation with Air Admitted at One Side of Ceiling and Drawn Out at the Other Side - - - - - | 323 |
| 220. Diagram showing Mechanical or Forced Air Circulation with Air Admitted at Each Side of Floor and Drawn Out at Centre of Ceiling - - - - - | 324 |
| 221. Diagram showing Mechanical or Forced Air Circulation with Air Admitted at One Side of Floor and Drawn Out at Other Side of Ceiling - - - - - | 324 |
| 222. Diagram showing Mechanical or Forced Air Circulation with Air Admitted at Two Ducts on Each Side of Wall and Drawn Out through Perforated False Ceiling - - - - - | 325 |
| 223. Diagram showing Mechanical or Forced Air Circulation with Air Admitted at One Broad Duct on Each Side Wall and Drawn Out through Perforated Ceiling - - - - - | 327 |
| 224. Diagram showing Mechanical or Forced Air Circulation with Air Admitted through Perforated Floor and Drawn Out through Perforated Ceiling - - - - - | 328 |
| 225. Door for Cold Store with Taylor's Patent Fittings - - - | 357 |
| 226, 227. Frick Co. Method of Insulating a Cold Store. Vertical and Horizontal Sections - - - - - | 358 |
| 228-235. Frick Co. Methods of Wall, Floor, Ceiling, Partition, Door, and Window Insulation - - - - - | 359 |
| 236. Frick Co. Method of Tank Insulation. Vertical Section - - - | 361 |
| 237-246. Barber Manufacturing Co. Methods of Wall, Floor, Ceiling, and Tank Insulation - - - - - | 362 |
| 247-254. Triumph Ice Machine Co. Methods of Wall, Floor, Ceiling, and Tank Insulation - - - - - | 363 |
| 255-265. Triumph Ice Machine Co. Methods of Wall and Floor Insulation | 364 |
| 266. Refrigerator Van or Waggon, Great Southern and Western Railway, Ireland. Sectional Side Elevation - - - - - | 366 |
| 267. Refrigerator Van or Waggon, Great Southern and Western Railway, Ireland. End Elevation Partly in Section - - - - - | 367 |
| 268. Refrigerator Van or Waggon, Great Southern and Western Railway, Ireland. Sectional Plan - - - - - | 368 |
| 269. Refrigerator Car or Waggon, Illinois Central Railway, U.S. Side Elevation Partly in Section - - - - - | 369 |
| 270. Refrigerator Car or Waggon, Illinois Central Railway, U.S. Sectional Plan - - - - - | 369 |
| 271-276. Childs' Patent Automatic Electrically-driven Beef Hoist - - - | 373 |
| 277. Childs' Patent Automatic Electrically-driven Beef Hoist. View showing a Quarter of Beef in Position - - - - - | 375 |
| 278. Mutton Hoist in London Cold Store - - - - - | 376 |
| 279. External Carcass Hoist at Nelson's Cold Storage Wharf, London. At Rest - - - - - | 377 |

LIST OF ILLUSTRATIONS.

xix

| FIG. | PAGE |
|--|------|
| 280. External Carcass Hoist at Nelson's Cold Storage Wharf, London. At Work - - - - - | 379 |
| 281. Lawton's Apparatus for Preserving Fruit. Diagrammatical View - | 390 |
| 282. Hall Horizontal Duplex Marine Type of Steam-driven Carbonic Acid Compression Machine - - - - - | 399 |
| 283. Hall Vertical Marine Type of Steam-driven Carbonic Acid Compres- sion Machine - - - - - | 400 |
| 284. Hall Small Marine Type of Steam-driven Carbonic Acid Compression Machine. Vertical Central Section - - - - - | 401 |
| 285. De La Vergne Vertical Single-acting Marine Type of Ammonia Compression Machine - - - - - | 402 |
| 286. Puplett Horizontal Marine Type of Steam-driven Ammonia Compres- sion Machine - - - - - | 403 |
| 287. Puplett Horizontal Marine Type of Belt-driven Ammonia Compres- sion Machine - - - - - | 403 |
| 288. Haslam Vertical Self-Contained Marine Type of Steam-driven Ammonia Compression Machine - - - - - | 404 |
| 289. Haslam Horizontal Marine Type of Steam-driven Compound Ammonia Compressor - - - - - | 405 |
| 290, 291. Kilbourn Horizontal Self-contained Marine Type of Steam-driven Double-acting Ammonia Compressor. Plan and Elevation, partly in Section - - - - - | 406 |
| 292. Kilbourn Horizontal Double-acting Marine Type of Belt-driven Ammonia Compressor - - - - - | 407 |
| 293, 294. Marine Type of Ammonia Condenser. Plan and Elevation, partly in Section - - - - - | 408 |
| 295. Insulation of Cargo Holds on board S.S. "Campania" and "Lucania." Transverse Section - - - - - | 409 |
| 296. Plan of Refrigerating Machine-room on Cunard Steamers - - - - | 410 |
| 297. Insulation of Provision Stores on board S.S. "Campania" and "Lucania." Transverse Section through Ceiling - - - - | 412 |
| 298. Insulation of Provision Stores on board S.S. "Campania" and "Lucania." Vertical Longitudinal Section through Ceiling - - | 412 |
| 299. Enock Electrically-driven Ammonia Compression Machine, Marine Pattern - - - - - | 413 |
| 300. Hall Vertical Marine Type of Steam-driven Cold-air Machine - - | 414 |
| 301. Haslam Vertical Marine Type of Steam-driven Cold-air Machine - - | 415 |
| 302. Haslam Vertical Marine Type of Steam-driven Cold-air Machine and Ice-making Apparatus - - - - - | 416 |
| 303. Arrangement of Cold Storage Chamber on board Large Passenger Steamer. Sectional Plan - - - - - | 418 |
| 304. Ice-making or Congealing Tanks or Boxes for Use on Shipboard. Plan, Side, and End Elevations, and Detail View - - - - | 419 |
| 305. Haslam Method of Sterilising the Cold Air for Use in Ships' Holds - - - - - | 420 |
| 306. Complete Milk-Cooling Plant with Warm Milk Tank and Milk Pumps. Enock Ammonia Compression System - - - - - | 424 |
| 307. Installation on Ammonia Compression System in Dairy. Kilbourn System - - - - - | 426 |

| FIG. | PAGE |
|--|----------|
| 308. Milk-Cooling Plant, Express Dairy Co., Ltd., London. Hall Carbonic Acid System - - - - - | 427 |
| 309. Installation for Milk Cooling on the Humboldt Sulphurous Acid System - - - - - | 428 |
| 310. Sandbach Combined Cream Cooler and Heater. Plan - - - | 430 |
| 311. Sandbach Combined Cream Cooler and Heater. Elevation - - | 430 |
| 312. Capillary Cream Cooler. Elevation - - - - - | 431 |
| 313. Creamery Refrigerator on the Air Circulation System. Plan and Detail Views - - - - - | 432 |
| 314. Creamery Refrigerator on the Air Circulation System. Section and Detail Views - - - - - | 432 |
| 315. Creamery Refrigerator on the Cylinder System. Plan and Section - - - - - | 434 |
| 316. Creamery Refrigerator on the Cylinder System. Detail Views - | 434 |
| 317. Burnand Ice Refrigerating Machine for Dairies - - - - | 436 |
| 318. Burnand Small Ice Milk Cooling Apparatus - - - - - | 437 |
| 319, 320. Enock Patent Chocolate Cooler or Economiser. Sectional Elevation and Cross Section - - - - - | 441 |
| 321. "Baudelot Cooler" with Direct Expansion for Cooling Beer Wort - | 446 |
| 322. "Baudelot Cooler" with Brine Circulation for Cooling Beer Wort - | 447 |
| 323. Arrangement for Cooling Fermenting and Yeast Rooms in Brewery on the Brine Circulation System - - - - - | 448 |
| 324. Arrangement for Cooling Fermenting Room on Direct Expansion Principle on the De La Vergne System - - - - - | 449 |
| 325. Frick Co. Method of Cooling a Fermenting Room in Brewery. Transverse Section - - - - - | 450 |
| 326, 327. Arrangement for Suspending Flat Pipe Coils from Ceiling on the Iron Floor Beams. Side Elevation and Transverse Section - | 451 |
| 328. Pipe Arrangement for Vault in Brewery. Transverse Section - | 452 |
| 329, 330. Frick Co. Automatic Attemperator System and Cooling Arrangement. Side Elevation and Plan - - - - - | 453 |
| 331. Arrangement for Cooling Water for Attemperating Purposes in Breweries with Ammonia Absorption Machine - - - - - | 454 |
| 332. Triumph Ice Machine Co., Small Brewery with Refrigerating Machinery Working on the Direct Expansion Principle. Sectional Elevation - - - - - | 458 |
| 333. Arrangement for the Extraction of Solid Paraffin from Shale Oil. Sectional Elevation - - - - - | 460 |
| 334. Refrigerating Arrangement in an Artificial Butter Factory. Sectional Elevation - - - - - | 462 |
| 335. Pontifex-Wood Brine Refrigerator - - - - - | 463 |
| 336, 337. Installation of Refrigerating Machinery (Haslam Type) for Desiccating 100,000 cubic feet of Air per Minute for use in Blast Furnaces. Perspective View and Plan View - - - - - | 467, 468 |
| 338. Gobert Congelation Method of Sinking Shafts. Vertical Section - | 478 |
| 339. Gobert Congelation Method of Sinking Shafts. Plan - - - | 479 |
| 340-342. Gobert Congelation Method of Sinking Shafts. Details of Construction - - - - - | 481 |
| 343. Pyramid Ice-making Box or Tank. Vertical Section - - - - | 487 |

LIST OF ILLUSTRATIONS.

xxi

| FIG. | PAGE |
|---|------|
| 344- Box or Tank for Making Ice on the Can System | 488 |
| 345. "Eclipse" Can Ice-making Tank or Box. Vertical Longitudinal Section | 489 |
| 346. Propeller for Circulating or Agitating Brine in Ice-making Tank or Box. Side Elevation | 490 |
| 347. Frick Pattern Brine Strainer. Vertical Central Section | 491 |
| 348. Arrangement of Freezing Tank on Can System showing Cause of Brine Foaming | 492 |
| 349. Box or Tank for Making Ice on the Plate or Wall System | 493 |
| 350. Pontifex-Wood Cell Ice-making Tank or Box | 498 |
| 351. Hill's Method of Making Clear or Crystal Ice. Plan of Box or Tank | 500 |
| 352. Method of Making Clear or Crystal Ice. Transverse Section on line $x-x$, Fig. 351 | 500 |
| 353. Modified Arrangement of Hill's Method of Making Clear or Crystal Ice. Horizontal Section | 501 |
| 354. Modified Arrangement of Hill's Method of Making Clear or Crystal Ice. Transverse Section on line x^1-x^1 , Fig. 353 | 501 |
| 355, 356. Haslam Patent Air Agitation Ice-making Plant. Sectional Elevation and Plan | 503 |
| 357. Oscillating Ice-making Tank or Box. Side Elevation | 504 |
| 358. Arrangement for Agitation of Water in Ice Cans by Means of Parti- tially Submerged Double-ported Plunger Pump. Sectional Elevation | 504 |
| 359. Arrangement for Agitation of Water in Fixed Ice Cans by Means of a Plunger or Piston Pump. Vertical Longitudinal Section | 505 |
| 360. Arrangement for Agitation of Water in Removable Ice Cans or Moulds by Means of Plunger Pumps. Transverse Section | 506 |
| 361. Arrangement for Agitation of Water to be Frozen in Ice-making Tank or Box by Long Horizontal Agitator. Transverse Sec- tion | 506 |
| 362. Arrangement for Agitation of Water to be Frozen in Ice-making Tank or Box by Means of Vertical Plunger Pump. Transverse Section | 507 |
| 363. Arrangement for Agitation of Water to be Frozen in Ice-making Tank or Box by Means of Horizontal Plunger Pump. Transverse Section | 507 |
| 364. Triumph Ice Machine Co. Oil Separator and Condensed Water-cooler. Plan | 509 |
| 365. Triumph Ice Machine Co. Oil Separator and Condensed Water-cooler. Vertical Section | 509 |
| 366. Frick Co. Apparatus for Making Distilled Water from Exhaust Steam. Diagrammatical View | 510 |
| 367. Diagram Illustrating Operation of Triple-effect Evaporating Ap- paratus | 511 |
| 368. Complete Single-effect Distilling Apparatus on the Yaryan System | 513 |
| 369. Complete Sextuple-effect Distilling Apparatus on the Yaryan System | 515 |

| FIG. | PAGE |
|--|------|
| 370. Ice-Tank or Box-room of Ice Factory on the Can System. Sectional Elevation - - - - - | 519 |
| 371. Ice-Tank or Box-room of Ice Factory on Plate or Wall System, showing Mechanism for Raising Slabs or Blocks of Ice - - - | 520 |
| 372-374. Frick Co. Plan for Ice Factory of 6 to 10 Tons Capacity. Plan, Sectional Side Elevation, and Transverse Section - - - | 521 |
| 375 377. Frick Co. Plan for Ice Factory of 30 to 35 Tons Capacity. Sectional Side and End Elevations, and Plan - - - | 522 |
| 378-380. Frick Co. Plan for Ice Factory of 100 Tons Capacity. Plan and Sectional Side and End Elevations - - - | 523 |
| 381, 382. Arrangement of Model Ice Factory by the Triumph Ice Machine Co. Plan and Sectional Elevation - - - | 524 |
| 383, 384. Vulcan Iron Works Arrangement for a 5-ton Ice Factory on the Can System. Plan and Sectional Elevation - - - | 525 |
| 385. Ice Factory on the "Eclipse" Can System, Constructed by the Frick Company. Sectional Elevation - - - | 526 |
| 386. Frick Ice-Can Hoist for Use with Small Ice-making Plants - - - | 527 |
| 387. Travelling Crane and Geared Hand-power Ice-Can Hoist - - - | 528 |
| 388. Electric Crane for Handling Ice Cans in Large Factories - - - | 528 |
| 389. Automatic Ice Dump - - - - - | 529 |
| 390. Vulcan Iron Works Track System - - - - - | 529 |
| 391. Brine Mixing Tank. Vertical Longitudinal Central Section - - - | 533 |
| 392. Haslam Brine Concentrator - - - - - | 534 |
| 393. 15-ton per Hour Power Ice-crushing Machine - - - | 538 |
| 394. Voorhees Oil Separator or Collector. Vertical Central Section - - - | 546 |
| 395. Yaryan Form of Oil Separator, Collector, or Interceptor. Vertical Central Section - - - - - | 548 |
| 396. Triumph Ice Machine Co. Ammonia Receiver and Oil Trap. Vertical Central Section and Detail Views - - - | 550 |
| 397. Stuffing Box and Packing for Ammonia Machines. Longitudinal Section - - - - - | 553 |
| 398. Mercury Well for Horizontal Pipe. Vertical Section - - - | 563 |
| 399, 400. Mercury Well for Vertical Pipe. Vertical and Horizontal Sections - - - - - | 563 |
| 401. Diagram from Compressor in Good Order - - - - - | 567 |
| 402. Diagram from Compressor Indicating an Excessive Amount of Clearance - - - - - | 567 |
| 403. Diagram from Compressor Indicating Binding of Pressure Valve - - - | 567 |
| 404. Diagram from Compressor Indicating Too Great a Resistance in Pressure and Suction Pipes - - - - - | 567 |
| 405. Diagram from Compressor Indicating Binding of Suction Valve - - - | 568 |
| 406. Diagram from Compressor Indicating Leaking of Compressor Valve - - - | 568 |
| 407. Diagram from Compressor Indicating Defective Packing of Piston - - - | 568 |
| 408. Diagram Illustrating Arrangement of Electric Lighting on the Series Circuit System - - - - - | 577 |
| 409. Diagram Illustrating Arrangement of Electric Lighting on the Parallel Circuit System - - - - - | 577 |
| 410. Diagram Illustrating the Cascade or Successive Cycle System of Producing Very Low Temperatures - - - - - | 589 |

LIST OF ILLUSTRATIONS.

xxiii

| FIG. | PAGE |
|--|------|
| 411. Diagram Illustrating Tripler's Apparatus for the Production of Very Low Temperatures by the Regenerative Method - - - | 594 |
| 412, 413. Hampson's Apparatus for the Production of Very Low Temperatures by the Regenerative Method. Vertical and Horizontal Sections - - - - - | 596 |
| 414. Linde's Apparatus for the Production of Very Low Temperatures by the Regenerative Process. Sectional Elevation - - - | 597 |

ERRATA.

Pages 130 and 148.—The descriptions of the illustrations in both cases should read “Horizontal Type” instead of “Vertical Type.”

of the water congealed—more palatable and sanitary than the natural product; to its extensive use for the freezing and chilling of freshly killed meat in abattoirs; and to its application to the cooling of stores or chambers for the preservation of meat, fowl, fish, butter, cheese, fruit, vegetables, and other provisions of a perishable nature: mechanical refrigeration is now commonly employed in a number of different manufacturing processes, brief descriptions of the most important of which applications will be found in a chapter devoted to this subject.

The trade in fresh provisions is one that during the last few years has made enormous strides, and at the present time vast quantities of frozen carcasses, and of fish, fruit, vegetables, butter, cheese, and milk are being imported into this country.

REPORT OF THE

Faint, illegible text at the top of the page, possibly a title or introductory paragraph.

APPENDIX

Faint, illegible text in the middle section, possibly a list or table of contents.

REFRIGERATION, COLD STORAGE, AND ICE-MAKING

CHAPTER I INTRODUCTION

Origin of Artificial Refrigeration—History and Progress of the Trade in Fresh Provisions.

ALTHOUGH refrigeration and the production of ice by artificial means is said to have been known to, and practised by, the Ancients, it is only in comparatively recent times that improved systems and apparatus have enabled operations to be carried out profitably on a commercial scale, and have rendered possible the numerous manufacturing and industrial applications now made.

In addition to the employment of mechanical refrigeration for the manufacture of ice, more durable, and—by reason of the known purity of the water congealed—more palatable and sanitary than the natural product; to its extensive use for the freezing and chilling of freshly killed meat in abattoirs; and to its application to the cooling of stores or chambers for the preservation of meat, fowl, fish, butter, cheese, fruit, vegetables, and other provisions of a perishable nature: mechanical refrigeration is now commonly employed in a number of different manufacturing processes, brief descriptions of the most important of which applications will be found in a chapter devoted to this subject.

The trade in fresh provisions is one that during the last few years has made enormous strides, and at the present time vast quantities of frozen carcasses, and of fish, fruit, vegetables, butter, cheese, and milk are being imported into this country.

Space does not, unfortunately, admit of entering into any lengthy account of the history of this trade, which is one of great interest, or of giving lengthy statistics relative to the constantly increasing amounts of these imports; the full figures can, however, readily be got from a variety of sources by anyone interested therein, and, moreover, they hardly come within the province of a book purporting to be devoted to a description of the various machines and appliances adapted for refrigeration and ice-making. The following, however, are a few of the leading facts and figures:—

Meat frozen by a Harrison ether machine was shipped from Melbourne on the 23rd July 1873, and arrived here on the 18th October, but turned out a failure. In 1875 and 1876 frozen meat was brought over from America. The first cargo of frozen meat was successfully brought to this country from Australia in the year 1880, in the "Strathleven," which is said to have been fitted with a Bell-Coleman cold-air machine, and this was quickly followed by another consignment in the "Protos," refrigerated by means of a cold-air machine of the Lightfoot pattern. On 5th October of the same year the steamship "Orient" arrived at London with a cargo of frozen meat, she being also fitted with refrigerating apparatus on the cold-air principle, in this instance one of Haslam's patent dry-air refrigerators being employed, which worked without interruption during the entire voyage of six weeks' duration. On the 26th September, in the succeeding year, the clipper ship "Mataura," also fitted with a Haslam patent cold-air machine, arrived with a cargo of frozen meat from New Zealand.

Such were the commencements of the trade in refrigerated meat, and it has so rapidly advanced that, in mutton and lamb alone, from 400 carcasses in 1880, it has risen to 12,981,044 carcasses in 1910. According to Messrs Weddel & Co.'s annual report, the total receipts of frozen mutton for 1910 was 7,552,977 carcasses, as compared with 5,915,455 in 1909. These figures represent an increase of 1,637,522 carcasses, or 27·7 per cent. These developments in mutton synchronised with a small extension in the imports of lamb, which aggregated 5,428,067 carcasses, as compared with 5,151,697 carcasses in 1909. Taking mutton and lamb together, the aggregate of the importations was 12,981,044 carcasses, as compared with 11,067,152 in 1909, and is the highest hitherto recorded.

The following tables compiled from statistics published by Messrs W. Weddel & Co. show, in the first, the growth of the trade in frozen mutton and lamb, from the commencement of the trade in 1880 to 1890; and in the second (page 4), from 1891 to 1910.

YEARLY IMPORTS OF FROZEN MUTTON AND LAMB FROM COMMENCEMENT OF THE TRADE TO 31ST DECEMBER 1890.

| Year. | Australia. | New Zealand. | Falkland Islands. | River Plate. | Totals. |
|-------|------------|--------------|-------------------|--------------|-----------|
| 1880 | 400 | ... | ... | ... | 400 |
| 1881 | 17,275 | ... | ... | ... | 17,275 |
| 1882 | 57,256 | 8,839 | ... | ... | 66,095 |
| 1883 | 63,733 | 120,893 | ... | 17,163 | 201,789 |
| 1884 | 111,745 | 412,349 | ... | 108,823 | 632,917 |
| 1885 | 95,051 | 492,269 | ... | 190,571 | 777,891 |
| 1886 | 66,960 | 655,888 | 30,000 | 434,699 | 1,187,547 |
| 1887 | 88,811 | 766,417 | 45,552 | 641,866 | 1,542,646 |
| 1888 | 112,214 | 939,231 | ... | 924,003 | 1,975,448 |
| 1889 | 86,547 | 1,068,286 | ... | 1,009,936 | 2,164,769 |
| 1890 | 207,984 | 1,533,393 | 10,168 | 1,195,531 | 2,947,076 |

The steady increase in the amounts of frozen and chilled beef imported into this country for the period of twenty years, viz., from 1891 to 1910, is no less phenomenal than that of mutton and lamb. In 1891 the total imports, as will be seen from the table on page 5, also compiled from Messrs W. Weddel's statistics, amounted to 1,157,854 cwt., whilst in 1910 the figures reached 4,246,182 cwt.

Three shipments of chilled beef were made during 1910 from Australia, the condition of one of which was imperfect owing to the use of unsatisfactory meat wraps. It has, however, been definitely proved that, aided by the Linley process, chilled beef can be brought from Australia or New Zealand to this market, and delivered, after a seventy days' voyage, in good condition.

The trade in frozen rabbits has also attained to considerable dimensions, and as far back as 1900, 36,823 crates, containing 917,142 rabbits, were sent to this country from South Australia.

In 1886 the steamship "Nonpareil" (Scrutton, Sons, & Co.), which had been fitted for the purpose with a Haslam dry-air refrigerator, brought to this country the first cargo of West Indian fruit; and early in 1888 a cargo of apples was shipped from Melbourne in the "Oceana," in chambers also cooled by a Haslam machine, both cargoes arriving in good condition. Subsequently many of the ships belonging to the Peninsular and Oriental Steamship Company, and others, were fitted up for this trade, and Messrs Elder, Dempster, & Co. inaugurated the Imperial West India Direct Mail Service, the steamers of which line are specially adapted for the transport of large quantities of bananas from Jamaica, a task which has been successfully performed. The

YEARLY IMPORTS OF FROZEN MUTTON AND LAMB FROM 1891 TO 1910.

| Year. | Carcasses of Mutton. | | | | | Carcasses of Lamb. | | | | | Totals (Mutton and Lamb). | |
|-------|----------------------|------------|--------------|------------|-----------|--------------------|---------------------|------------|--------------|------------|---------------------------|------------|
| | Uruguay, Patagonia. | Argentina. | New Zealand. | Australia. | Totals. | Year. | Uruguay, Patagonia. | Argentina. | New Zealand. | Australia. | | Totals. |
| 1891 | ... | 1,130,034 | 1,535,106 | 334,684 | 2,999,824 | 1891 | ... | ... | 358,999 | ... | 358,999 | 3,358,823 |
| 1892 | ... | 1,265,679 | 1,260,882 | 504,738 | 3,031,299 | 1892 | ... | ... | 278,723 | ... | 278,723 | 3,310,022 |
| 1893 | ... | 1,385,706 | 1,428,772 | 605,660 | 3,420,138 | 1893 | ... | 4,712 | 470,251 | 9,222 | 484,185 | 3,904,323 |
| 1894 | ... | 1,426,056 | 1,512,455 | 923,775 | 3,862,286 | 1894 | ... | 434 | 445,804 | 15,585 | 461,823 | 4,324,109 |
| 1895 | ... | 1,630,448 | 1,676,928 | 922,246 | 4,229,622 | 1895 | ... | 4,785 | 732,649 | 46,655 | 784,089 | 5,013,711 |
| 1896 | ... | 1,786,305 | 1,425,067 | 1,533,139 | 4,744,511 | 1896 | ... | 5,975 | 786,828 | 110,104 | 902,907 | 5,647,418 |
| 1897 | ... | 2,109,521 | 1,682,123 | 1,312,855 | 5,104,499 | 1897 | ... | 11,950 | 1,021,722 | 94,562 | 1,128,234 | 6,232,733 |
| 1898 | ... | 2,390,615 | 1,647,041 | 1,159,319 | 5,196,975 | 1898 | ... | 6,722 | 1,137,060 | 89,334 | 1,233,116 | 6,430,091 |
| 1899 | ... | 2,411,339 | 2,011,175 | 971,101 | 5,393,615 | 1899 | ... | 3,379 | 1,238,925 | 233,500 | 1,475,804 | 6,869,419 |
| 1900 | ... | 2,329,545 | 1,862,149 | 627,945 | 4,819,639 | 1900 | ... | 3,266 | 1,395,788 | 315,979 | 1,711,767 | 6,433,821 |
| 1901 | ... | 2,630,839 | 1,838,333 | 796,655 | 5,265,827 | 1901 | ... | 112,027 | 1,788,100 | 429,903 | 2,218,027 | 7,094,782 |
| 1902 | ... | 2,715,469 | 1,879,961 | 186,753 | 4,782,183 | 1902 | ... | 174,449 | 2,157,679 | 537,544 | 2,437,671 | 7,219,854 |
| 1903 | ... | 2,943,988 | 2,426,081 | 213,880 | 5,583,949 | 1903 | ... | 207,141 | 1,904,592 | 328,524 | 2,440,257 | 8,180,234 |
| 1904 | ... | 2,730,560 | 1,980,639 | 121,799 | 4,832,998 | 1904 | ... | 2,201 | 1,953,337 | 906,536 | 3,032,953 | 7,273,255 |
| 1905 | 163,520 | 2,866,610 | 1,751,229 | 461,902 | 5,243,261 | 1905 | 2,201 | 170,879 | 2,386,829 | 1,173,896 | 3,680,831 | 8,276,214 |
| 1906 | 150,972 | 2,648,198 | 1,761,459 | 558,432 | 5,119,061 | 1906 | 15,378 | 104,728 | 2,824,332 | 1,397,554 | 4,348,992 | 8,799,892 |
| 1907 | 234,066 | 2,654,057 | 1,973,035 | 940,377 | 5,801,535 | 1907 | 24,951 | 102,155 | 2,543,751 | 1,206,179 | 4,072,858 | 10,150,527 |
| 1908 | 319,726 | 2,943,360 | 1,690,407 | 625,067 | 5,578,560 | 1908 | 78,594 | 244,334 | 3,165,504 | 1,331,697 | 5,151,697 | 9,651,418 |
| 1909 | 335,731 | 2,382,984 | 1,869,599 | 1,327,141 | 5,915,455 | 1909 | 130,033 | 504,463 | 3,165,504 | 1,331,697 | 5,151,697 | 11,067,152 |
| 1910 | 384,313 | 2,454,401 | 1,991,115 | 2,723,148 | 7,552,977 | 1910 | 162,547 | 352,501 | 3,416,359 | 1,496,660 | 5,428,067 | 12,981,044 |

The total capacity of the principal London refrigerating stores at the 31st December 1910 in 56-lb. sheep was 2,783,000 carcasses.

YEARLY IMPORTS OF FROZEN AND CHILLED BEEF FROM 1891 TO 1910.

| | | Quarters of Beef—Frozen.* | | | | | Quarters of Beef—Chilled.‡ | | | |
|-------|--------------------------------------|---------------------------|-----------------|------------|-----------|-------|---|------------|-----------|--|
| Year. | Uruguay, Patagonia, Venezuela. | Argentina. | New Zealand. | Australia. | Totals. | Year. | North America (Numbers Estimated on Basis of Weight). | Argentina. | Totals. | Totals of Beef Frozen and Chilled. |
| 1891 | ... | 9,660 | 70,226 | 28,968 | 108,854 | 1891 | 1,049,000 | ... | 1,049,000 | 1,157,854 |
| 1892 | ... | 5,540 | 41,380 | 37,710 | 84,630 | 1892 | 1,171,000 | ... | 1,171,000 | 1,255,630 |
| 1893 | ... | 30,718 | 8,691 | 141,861 | 181,270 | 1893 | 894,000 | ... | 894,000 | 1,075,270 |
| 1894 | ... | 3,844 | 1,044 | 169,581 | 174,469 | 1894 | 1,065,000 | ... | 1,065,000 | 1,239,469 |
| 1895 | ... | 10,337 | 5,527 | 304,780 | 320,644 | 1895 | 990,000 | ... | 990,000 | 1,310,644 |
| 1896 | ... | 28,368 | 15,612 | 321,468 | 365,448 | 1896 | 1,245,000 | ... | 1,245,000 | 1,610,448 |
| 1897 | ... | 46,606 | 25,236 | 377,179 | 449,021 | 1897 | 1,345,000 | ... | 1,345,000 | 1,794,021 |
| 1898 | ... | 66,872 | 51,799 | 360,017 | 478,688 | 1898 | 1,381,000 | ... | 1,381,000 | 1,859,688 |
| 1899 | ... | 98,016 | 86,236 | 346,464 | 530,736 | 1899 | 1,654,000 | ... | 1,654,000 | 2,184,736 |
| 1900 | ... | 249,065 | 186,082 | 275,879 | 711,026 | 1900 | 1,720,000 | ... | 1,720,000 | 2,431,026 |
| 1901 | ... | 440,864 | 140,300 | 160,774 | 741,938 | 1901 | 1,909,000 | ... | 1,933,919 | 2,675,857 |
| 1902 | ... | 488,876 | 153,536 | 43,609 | 686,021 | 1902 | 1,374,000 | 24,919 | 1,468,498 | 2,154,519 |
| 1903 | ... | 565,642 | 91,994 | 45,587 | 703,223 | 1903 | 1,616,000 | 94,498 | 1,758,542 | 2,461,765 |
| 1904 | ... | 789,109 | 104,467 | 46,537 | 940,113 | 1904 | 1,438,000 | 198,300 | 1,636,300 | 2,576,413 |
| 1905 | 16,082 | 1,152,051 | 89,463 | 10,276 | 1,267,872 | 1905 | 1,339,000 | 402,195 | 1,741,195 | 3,009,067 |
| 1906 | 16,265 | 1,298,438 | 121,858 | 13,112 | 1,449,673 | 1906 | 1,456,000 | 454,613 | 1,910,613 | 3,360,286 |
| 1907 | 55,671 | 1,265,439 | 220,162 | 73,117 | 1,614,389 | 1907 | 1,451,000 | 427,042 | 1,878,042 | 3,492,431 |
| 1908 | 85,992 | 1,447,365 | 179,002 | 75,800 | 1,788,159 | 1908 | 859,000 | 767,284 | 1,626,284 | 3,414,443 |
| 1909 | 98,717 | 1,491,368 | 297,328 | +269,588 | 2,157,001 | 1909 | 521,000 | 1,066,134 | 1,587,134 | 3,744,135 |
| 1910 | 148,084 | 1,336,757 | 344,048 | +537,442 | 2,366,331 | 1910 | 286,850 | 1,593,001 | 1,879,851 | 4,246,182 |

* Frozen beef is that carried at a temperature of 10° Fahr. to 15° Fahr. and frozen hard.

+ Including 1,331 quarters chilled from Queensland.

‡ Including 3,844 quarters chilled from Queensland.

§ Chilled beef is that carried at a temperature of 29° Fahr. to 30° Fahr. and arriving in a soft condition.

method adopted is to circulate through the insulated holds of the vessel air which has been purified and cooled in the course of its passage over a specially constructed cooler, through which cold brine is circulated by means of pumps, and every precaution is taken to maintain an equable temperature of 40° to 45° Fahr. during the voyage. Besides this there is now quite a large trade in Australian and Canadian apples, and one in soft fruits, such as pears, peaches, and grapes, has also been established. The extent of the trade in Canadian fruit will be realised from the fact that during the season of 1908 there were four steamers sailing from the ports of Montreal and Quebec with cold storage chambers reserved for fruit only. The total number of vessels fitted with cold storage, sailing from the above ports in the same year was forty-six steamers with a cold storage capacity of 1,015,556 cub. ft., and nineteen with a total air cooled capacity of 904,780 cub. ft. Adding together all the sailings during the year, the total available space was 4,907,195 cub. ft. of cold storage, and 4,217,648 cub. ft. of cooled air.

In 1893 a considerable import trade in milk had already arisen, and in 1894 one firm alone regularly sold 500 gals. of foreign milk daily; thousands of gallons of foreign cream are likewise imported into this country to be used for buttermaking. The bulk of this milk is shipped to London from Gothenburg by steamer, having been frozen chiefly by refrigerating machines on the ammonia compression principle, and costing, it is stated, 25 per cent. less than English milk.

Large quantities of butter are brought over from Denmark and the Baltic. Messrs Thos. Wilson, Sons, & Co. alone had eight or ten years ago seven steamships fitted up with refrigerating machinery for the butter trade, and one firm of refrigerating engineers (Messrs J. & E. Hall, Ltd.) had at that time fitted up thirty steamers with refrigerating installations for the same trade, and a large number of steamers have since been adapted for such transport. The amount of butter imported into the United Kingdom from Victoria, in 1900, was 26,185,679 lbs., that from New South Wales 8,727,600 lbs., and large quantities of butter and cheese are likewise brought over from Canada.

All these provisions can now be brought to this country in excellent condition, the chief dangers of deterioration being from hurried and consequently careless stowing, from bumps and bruises caused by rough and unskilled handling, and from exposure to higher temperatures during transit from the vessel to the cold stores on land, and subsequent distribution by road or rail to the retailers.

There are at the present time upwards of 200 cold stores and ice factories in the United Kingdom. The number of firms engaged as makers of refrigerating machinery is about 40, and there are upwards of 130 breweries, 30 butter merchants, 45 chemical and other manufactories, 30 chocolate, cocoa, and confectionery manufacturers, and some 65 bacon factories using refrigeration; as well as manufacturers of ammonia, carbonic anhydride, and other refrigerating mediums, importers of ice, and other firms interested in the business; many butchers, fishmongers, dairy and hotel proprietors, and others, who have small cold stores cooled by refrigerating machinery and by ice. On the Continent and in America and spread over China, Japan, Java, India, Ceylon, the Malay Peninsula, the Philippine Islands, Siam, East, West, and South Africa, Australia, New Zealand, Egypt, and Algeria are many thousand firms directly interested in refrigeration.

In twenty states in the United States the refrigeration used per day amounted, according to statistics compiled in 1909, to 284,780 tons. The total capacity of the refrigerating machines in the United States is given as being 612,919 tons per day of twenty-four hours. That is an average of 31.17 tons per machine. The capital represented in the above plants is considerably above 100,000,000 dollars.

The entire number of vessels fitted up with refrigerating installations and adapted for the transport of meat and other comestibles was in 1910 upwards of 800. According to Messrs W. Weddel 189 steamers were actually engaged in the frozen meat trade between Australia, New Zealand, and South America, and this country, at the 31st December 1910, viz., 52 steamers having a combined capacity of 2,264,000 carcasses between Australia, 49 steamers with a combined capacity of 4,498,200 carcasses between New Zealand, 68 steamers with a combined capacity of 4,166,700 between South America, and 20 steamers with a combined capacity of 1,709,700 between Australia, &c., or South America, and the United Kingdom. There is also a supplementary list of 25 steamers fitted with refrigerating machinery, and having a combined carrying capacity of 1,586,900 carcasses, but not at present engaged in the frozen meat trade.

CHAPTER II

THE THEORY AND PRACTICE OF MECHANICAL REFRIGERATION

Relation to first two Laws of Thermo-dynamics—Definition of Heat—Specific Heat—Latent Heat—Mechanical Equivalent of Heat—Calculations made with respect to Heat—Temperature—Laws of Gases—Construction of Chart applicable to any value of n —Work demanded of a Refrigerating Machine—Greatest Theoretical Efficiency of a Refrigerating Machine.

THE theory and practice of mechanical refrigeration are based upon the two first laws of thermo-dynamics—that is to say, first that mechanical energy is convertible into heat, and *vice versâ*, and, second, that an external agent is necessary to enable heat to pass from a cold to a heated body.

The above fact very naturally leads us to inquire what heat really is, and here we are confronted with a question by no means easy to answer correctly. According to the well-known and generally accepted definition of text-books, the answer to the question is that heat is a mode of motion. A more satisfactory statement as to the nature of heat, however, is that it is a form of molecular energy. This theory is the result of a series of observations made by Benjamin Thompson, better known, perhaps, as Count Rumford, in the year 1798, and also by Sir Humphry Davy in the year 1799, the definition having been finally arrived at, and accepted by, the former eminent scientist in 1812. It is an unfortunate circumstance, but nevertheless a true one, that even the most gifted amongst scientific men, in endeavouring to penetrate the secrets of nature, are, after all is said and done, but groping blindly in the dark, and the fallacy of but too many of our scientific definitions is a truth patent to all who give the subject any serious consideration. This is a fact fully recognised by most eminent teachers; but notwithstanding this, the erroneous definitions are allowed to stand unchallenged for want, doubtless, of more accurate ones.

In the case of heat, the before-mentioned experiments had appa-

rently shown that heat was not a substance, as had been thought by previous authorities, and therefore it was accepted without dispute, in order to secure a plausible definition, as being a mode of motion. In a very interesting paper by Dr Ernst Mach, Professor of Physics in the University of Prague, which appeared in the *Monist* of October 1894, the absurdity of many of the universally accepted theories is clearly demonstrated, and with reference to thermodynamics, he remarks that, as it has been shown that heat is not a substance, the usually accepted theory is that it is a mode of motion. This, however, Dr Mach proves not to be true. In an able article upon the fallacy of scientific definitions published in the *Engineer* of 12th October 1894, the writer, 'after referring to the fact that the exact nature of heat is as yet absolutely unknown, truly observes that heat really behaves sometimes like a substance and sometimes not.

Modern physicists assume heat to be not a material but a state. All bodies are built up of very large numbers of extremely minute particles, known as molecules, which have a mutual attraction the one for the other, which attraction is more or less great in solid matter, lesser in liquid matter, and actually resolves itself into a repulsion in gaseous matter. These molecules are supposed to be in a state of perpetual movement or vibration, except in the case of bodies which are absolutely cold, and the temperature of a body is governed by the rate of this vibration, the more rapid the vibration the higher the temperature. Every molecule possesses a certain definite weight, and owing to its motion must have a certain amount of kinetic energy, so that according to this heat is really a kind of energy, and not a substance. Both heat and mechanical energy are mutually convertible, and besides, for each unit of heat expended or produced, a definite amount of mechanical work must be produced or expended.

Lord Armstrong said: "According to the new theory, heat is an internal motion of molecules, capable of being communicated from the molecules of one body to those of another; the result of this imparted motion being either an increase of temperature or the performance of work. Clausius states that heat cannot be communicated from a cold body to a hotter one without compensation. According to Tyndall heat is not matter, but an accident or condition of matter, namely, a motion of its ultimate particles. Maxwell says that heat, considered with respect to its power of warming things, and changing their state, is a quantity strictly

capable of measurement, and not subject to any variation in quality or kind. Balfour Stewart says that when air is compressed, the rise of temperature is scarcely at all due to the mere diminution of the distance between the particles, but almost entirely to the mechanical effect which must be spent on the air before the condensation can be produced."

It may here be remarked that the word heat is very commonly employed in a very loose manner, and the fact that two quite distinct meanings may attach themselves to it is either forgotten or ignored, viz., "temperature" and "quantity of heat," which, whilst closely connected with one another, are nevertheless entirely different. For example, we may have two vessels of largely varying dimensions containing water at exactly the same temperature, whilst the quantity of heat in the larger vessel may be double, treble, or more, of that in the other or smaller one. Sensible heat is that indicated by the thermometer.

Specific heat is defined as being that amount of heat necessary to raise the temperature of a body of a unit weight 1° . The unit of measure is that quantity of heat that is necessary in order to raise the unit weight of water through 1° , at its temperature of maximum density $39\cdot4^{\circ}$ Fahr. If equal weights of different bodies are raised the same number of degrees of temperature, each one takes up a different amount of heat, moreover the specific heat of the same substance differs in accordance with its state, *i.e.*, whether it be solid, liquid, or gaseous, and under varying conditions of temperature and pressure, increasing invariably with an increase of temperature or pressure. The specific heat of water is exceeded by but few bodies, and the variation thereof at different temperatures is so small as to be unworthy of notice. The specific heat of water is therefore taken as the standard of comparison, and is represented by unity. It is, however, a quantity increasing with the temperature; for example, at the temperature of maximum density 39° Fahr. to 40° Fahr., it is exactly unity, at 104° Fahr. it is $1\cdot0012$, and at 212° Fahr. it is $1\cdot005$.

Latent heat, the existence of which was first discovered by Dr Black in 1762, is the heat that is absorbed by bodies when passing from one state to another. Latent heat has been thus clearly and concisely defined by Balfour Stewart, in his "Treatise on Heat": "Latent heat is the heat which is absorbed by bodies in passing from one state to another, but it does not manifest itself by producing an increase of temperature, and is on this account called latent heat. . . . A pound of water at 212° , mixed with a pound of water at 32° , gives 2 lbs. of water at 122° , the mean of the two components; if, however, a pound

of ice at 32° be mixed with a pound of water at 212° , we have 2 lbs. of water at 51° only. . . . The difference being equal to that required to raise 2 lbs. of water through a range of 71° . . . representing the heat required to liquefy 1 lb. of ice."

Joule's mechanical equivalent of heat equals 772 ft.-lbs. That is to say that heat demands for its production, and produces by its disappearance, 772 ft.-lbs. for each unit of heat. The experiments by which Joule determined the above equivalent were conducted by means of a falling weight, which actuated an agitator or paddle-wheel placed in water, the friction caused by a weight of 1 lb. falling through a distance of 772 ft., or of a weight of 772 lbs. falling through a distance of 1 ft., being found sufficient to heat 1 lb. of water 1° Fahr.

The method of conducting the experiment consisted in first winding up the weight until it was at the top of a scale, the temperature of the fluid (water, oil, mercury, &c.) being then noted, and the weight allowed to fall through a certain distance and the temperature again noted. If then W be the weight in lbs., and H the height through which the weight has fallen in feet, $W \times H$ will be the number of foot-pounds of work that have been performed by the falling weight. And if $w \times s$ be the weight of the fluid multiplied by its specific heat, t_1 be the initial temperature of the fluid, and t_2 be its final temperature, $w \times s (t_2 - t_1)$ will be the number of heat units imparted to the fluid by the fall of the weight. Taking J (usually known as Joule's equivalent) to denote the number of foot-pounds required to produce one heat unit, or the mechanical equivalent of heat, we have therefore:—

$$J = \frac{WH}{w \times s (t_2 - t_1)}$$

This is what is generally called the first law of thermo-dynamics, viz., heat and mechanical energy are mutually convertible, and heat requires for its production or produces by its disappearance, mechanical energy in the proportion of 772 ft.-lbs. for 1 unit of heat.

This value has been used universally for many years, being even now that most commonly employed. Recent investigators, however, have conclusively shown that the above is too small, and various values varying up to 778 ft.-lbs. are used.

Calculations made with respect to heat entail the use of the terms absolute pressure and temperature.

The first of these, or absolute pressure, is pounds per square inch above a vacuum. Hence, as the zero on a steam pressure gauge

represents atmospheric pressure it will be necessary to add 14·7 lbs. to any particular gauge pressure to convert it into absolute pressure.

Temperature is a term which implies that degree of sensible heat which a body possesses when compared with another body. The zero upon the Fahrenheit thermometrical scale is an arbitrary zero or starting point, adopted because the real zero was unknown; recent experiments place it at $-459\cdot13^\circ$ Fahr. On both the Centigrade and Reaumur scales the two fixed points are the temperatures of melting ice and boiling water under a pressure due to that of the standard atmosphere. A degree is obtained by dividing the interval between these points into 180 in the case of the Fahrenheit, 100 in the case of the Centigrade, and 80 in the case of the Reaumur, equal divisions on the three scales, the bore of the tube being assumed to be uniform and the expansion of the glass neglected. Thus the absolute temperature of a body is that of absolute zero added to the ordinary thermometrical temperature thereof. For instance, if the latter be 32° Fahr. then the absolute temperature would be $491\cdot13^\circ$ Fahr., or $459\cdot13$ were it zero Fahrenheit on the thermometer.

The laws of gases may be concisely stated as follows:—

$$PV = RT :$$

Where P = pressure

V = volume

R = constant (depending upon the gas)

T = absolute temperature

= $(T + 459\cdot13^*)$ on Fahrenheit scale.

The equation may be put as follows:—

$$\frac{PV}{T} = \text{constant.}$$

If temperature remains constant then

$$PV = a \text{ constant.}$$

And in this form is the algebraical representation of Boyle's or Marriotte's law, usually expressed in words thus: If the temperature remain constant then the volume of any given quantity of gas will be in the inverse ratio to the pressure which it sustains.

The volume remaining constant then

$$\frac{V}{T} = a \text{ constant.}$$

Which is the symbolic expression of Charles' and Gay Lussac's

* Figures given by Professor Clerk Maxwell in his "Theory of Heat." 460 is the amount generally taken.

laws (laws of expansion). Charles' law may be orated thus: Under constant pressure all gases expand alike.

$$PV^n = \text{constant.}$$

In cases where the change of volume takes place at constant temperature, then it is said to be isothermal expansion and $n = 1$. The curve connecting pressure and volume is an hyperbola, and consequently it is occasionally called hyperbolic expansion.

If the working medium or agent expand without receiving or giving up any heat from or to external bodies, it is said to expand adiabatically, the curve of expansion is adiabatic and $n = \text{ratio of specific heat at constant pressure to the specific heat at constant volume, which for air} = 1.408$, or

$$PV^{1.408} = \text{constant.}$$

This particular ratio is usually denoted by γ , or

$$PV^\gamma = \text{constant.}$$

To construct the curve $PV^n = \text{constant}$.

When $n = 1$ then for a given series of values of V it is easy to calculate the corresponding values of P , but for any other value of n it is necessary to use logarithms, thus:—

$$\log. P + n \log. V = \log. C; \quad . \quad . \quad . \quad (1)$$

Put $\log. P = y$, $\log. V = x$, and $\log. C = k$, then equation (1) may be written:—

$$y + nx = k,$$

which is the equation to a straight line.

In Fig. 1 take the point R in the straight line AB, then $CR = OD = x_1$, and $RD = OC = y_1$; then from the figure we have—

$$\frac{OA}{OB} = \frac{AC}{CR} = \frac{OA - CO}{CR} = \frac{OARD}{CR} = \frac{OA}{CR} - \frac{RD}{CR};$$

$$\therefore RD + \frac{OA}{OB} \cdot CR = OA$$

$$\text{or, } y_1 + nx_1 = k;$$

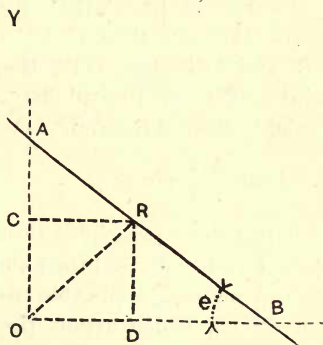

Fig. 1.—Diagram showing Method of Construction of Curve $PV^n = \text{Constant}$.

and similarly for any other point (xy) in the line it may be shown that—

$$y + nx = k.$$

Also let the angle $ABO = D$, then $n = \tan. D = \frac{AO}{OB}$.

In Fig. 2 let $A'R'B'$ be the curve $PV^n = C$, then if $CR = \log. C'R'$ and $DR = \log. D'R'$, then all points such as R will lie on a straight line AB, and $AO = \log. C$, whilst $\frac{AO}{BO} = n$.

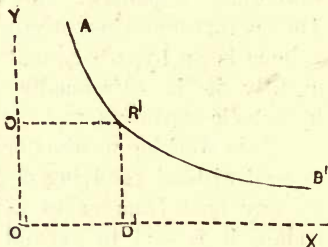

Fig. 2.—Diagram showing Method of Constructing Curve $PV^n = \text{Constant}$.

Upon these principles Professor D. A. Low has devised the following general method applicable to any value of n , which avoids the continual use of a table of logarithms.

For this purpose a chart is constructed (see Fig. 3), which may be considered divided up into four parts by the lines X_1X and Y_1Y . Volumes are measured along OX , pressures along OY as usual, so that the top right-hand corner is the curve $PV^n = \text{constant}$. $\log. P$ is measured along OX_1 , and $\log. V$ along OY_1 . A curve is drawn in the top left-hand corner such that any point Q in it satisfies the conditions $QS = P$ and $QT = \log. P$. Similarly in the right-hand lower corner is a second curve in which any point K_1 must satisfy the conditions $KL = V_1$ and $KM = \log. V$. These curves will be used for constructional purposes and should be carefully drawn.

Let A (Fig. 3) be a point in the curve $PV^n = C$, and also that n has the value 1.4, the pressure at A being 140 lbs., and the ^{volume} value 10 units. Then project a vertical line downwards to meet the V $\log. V$ curve at a , and a line horizontally to meet the P $\log. P$ curve at a' . From a' let fall a perpendicular to meet a horizontal line through a , at a'' . Join the point 1.4 on scale of $\log. P$ to 1.0 on scale of $\log. V$ and through a'' draw a line parallel to this line. Next select some point, say b'' , and project vertically and horizontally, obtaining the points b' and b'' , again projecting horizontally and vertically, and their intersection B is a point on the curve required; repeat this process for as many points as may be required. All this process requires is the use of a tee-square and set-square; and in practice if the two curves are constructed once for all and the construction performed upon a piece of tracing paper, the original can be then preserved uninjured. The converse problem

can be solved, viz., if a curve UV be given to find the nearest value of n in the equation $PV^n = C$. In this case take a number of points, 1, 2, 3, &c., and draw the *straight* line $u''v''$ through them, and through the point 1.0 (in log. V) draw a parallel line to $u''v''$, to intersect log. P scale (OX_1), then the reading in this example 0.8 nearly. So that the equation to the curve UV is $PV^{0.8} = 1313$.

The work demanded of a machine of any kind whatsoever intended for effecting mechanical refrigeration is to reduce the temperature of any given matter to the desired point as compared with the surround-

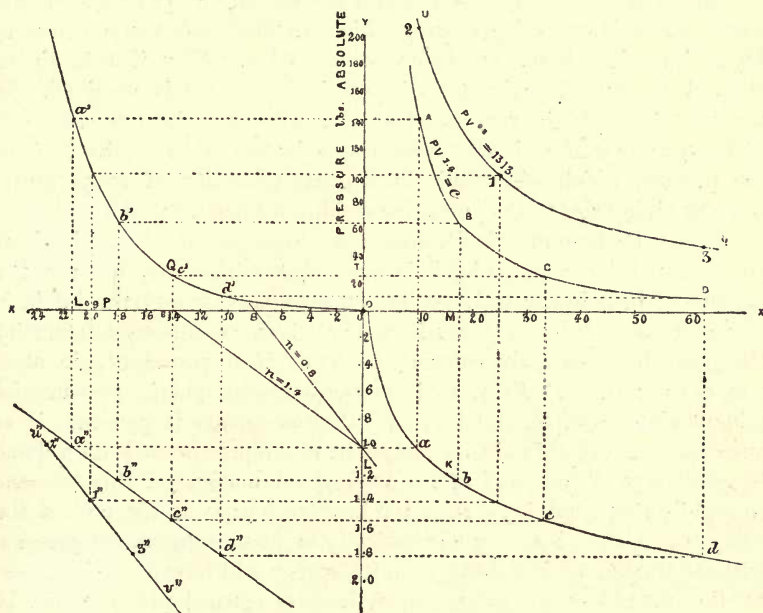

Fig. 3.—Construction of Chart applicable to any value of n .

ing matter, and to maintain it subsequently at or near this point, for naturally, were two bodies having different temperatures placed either in actual contact or in sufficiently close proximity to one another, their temperatures must infallibly become equalised sooner or later, if no means be employed to permanently keep up the difference. It may here be noted that the theoretical cycle of a perfect refrigerating machine is precisely the opposite to that of a perfect heat engine. In the first, heat goes in at a low temperature and passes out at a more elevated temperature, to render which action possible certain work has

to be effected upon it. In the second, heat derived from some external source at an elevated temperature is given out at a lower temperature, a greater or lesser amount of mechanical work being produced by it during its fall.

When a gas is compressed the temperature rises. When a gas is allowed to expand, the work it performs is done at the expense of its store of heat. If, therefore, some gas, say air, be compressed its temperature will increase, and some of its heat will be able to flow into any surrounding bodies at a lower temperature, and in cold-air machinery air is compressed, and then cooled by passing through water at a lower temperature, which reduces the temperature to about its original amount before compression. Now if this air be allowed to expand again until its original pressure is regained, the work so done will be performed at the expense of its reduced stock of heat, so that the air will have lost a large portion of its heat in the process, which will result in a great reduction of temperature, thereby giving rise to that negative condition known as cold.

It may be here mentioned that the phrase commonly used, "heat is generated by compression," is somewhat misleading, because the amount of heat in the universe is a fixed quantity, and the intrinsic energy possessed by any gas is under given conditions a quantity that can be accurately calculated. Thus if a pound of air at a temperature of 70° Fahr. and at normal atmospheric pressure be taken as an example, the total quantity of energy it possesses is at once known. If this air be placed in a compressor and its volume be reduced to say one half of its original volume, and if this be done so rapidly that there is no time for heat to escape at the end of the compression, that is to say adiabatically or instantaneous compression without transmission of heat, then its energy will have been increased by the amount of work done upon it. Its statical pressure will be increased, and its temperature will also have risen, by reason of its changed state or condition internally, and the theta-phi diagram for the two conditions would show this more clearly than any other known method. Now if the temperature be reduced to its former amount, that is to say to 70° Fahr., its volume will contract, so that a small additional quantity of air will have to be forced in in order that the pressure may remain unchanged as the temperature is reduced. It will be seen that there will be now, consequently upon the above, rather more than a pound of air to deal with at the higher pressure, and this is what actually occurs in practice, but is a point which is easily overlooked. Now if this air be allowed to expand in

a cylinder, it will give up more of its heat in order to overcome the resistance, and in this way it will lose or part with more heat. The amount of work done is shown by the indicator card, and can be estimated. The mechanical work done by the air in this expansion is exactly the same as that done upon it during its compression, but there is in addition the further loss of energy, due to the internal work done in the air during the expansion, so that what has been done to the air during the entire process has been to extract some of its original store of heat, thus reducing its temperature; and the cold air is now ready to restore its deficiency at the expense of the surrounding hotter bodies.

The greatest theoretical efficiency of a refrigerating machine is expressible by the equation:—

$$\frac{X}{X^1} = \frac{Y}{Z - Y};$$

X denoting the heat units which are abstracted.

X¹ denoting the total of heat units representing work effected.

Y denoting the absolute lower temperature.

Z denoting the absolute higher temperature.

In all refrigerating machines, other matters being equal, a limited range of temperature gives the largest amount of efficiency, and the more extended the range of temperature the less will be the degree of efficiency developed; the efficiency, moreover, advances proportionately to a rise in the lowest limit of the range of temperature.

Shortly, the work demanded of a refrigerating machine is to extract heat from a cold body, say from the air in an enclosed space, such as a refrigerating chamber, and by the expenditure of mechanical energy to sufficiently raise the temperature of this heat to admit of its being carried away by a suitable external agent, the latter being most usually water, which is not only the cheapest one available, but also has a greater capacity for heat, weight for weight, than any other known substance, and is taken as the standard of comparison, its specific heat being taken as unity.

It has been already stated that heat cannot be communicated from a cold body to one at a higher temperature without compensation taking place, and as the heating of cold bodies is not refrigeration, an explanation of the nature, extent, and necessity of this compensation is called for.

Let us suppose that it is desired to cool some agent or medium, say air for an example, at a temperature of 60° Fahr., a liquid at a temperature of zero Fahrenheit being available which has, say, the same

specific heat as water. On mixing 100 cub. ft. of this air with 10 lbs. of the liquid, it will be found, as soon as the temperatures have become equalised, that the air has been cooled 50°, and the liquid heated 10°, practically no expenditure of power being required to effect the mixing.

On the other hand, supposing that it is desired to cool air at a temperature of 60° Fahr., and that water at 80° Fahr. is available for the purpose of absorbing the heat, then in this case as the substance to be cooled is the colder body, some means must be found of reversing the relative temperatures of the two substances. According to Boyle's or Mariotte's law, the temperature remaining the same, the volume of any given quantity of gas will be in the inverse ratio to the pressure which it sustains. By compressing the 100 cub. ft. of air to seven-tenths of its volume, the terminal temperature will be found to be 140° Fahr., and if this air be mixed whilst under pressure with 10 lbs. of water at a temperature of 80° Fahr., it will be found, as soon as the temperatures become equalised, that both the air and the water are at a temperature of 90°. By allowing this air to expand to normal pressure, its final temperature will be found to be 10° Fahr., or reduced to a similar temperature as in the first case. In the above example, the compression, cooling, and expansion are assumed to be all effected in the same cylinder, and without transference of heat to or from the exterior.

It will be seen that, in both of the above cases, 100 cub. ft. of air has been reduced in temperature by 50° Fahr. The heat removed or abstracted was in the first instance communicated to a liquid at a low temperature, no compensation taking place, whilst in the second case the heat removed or abstracted was taken up by water at an initial temperature considerably above that of the air, which action necessitated the temperature of the latter being raised by compression, thereby consuming a certain amount of power in doing so, which consumption of power in the above case, allowing for friction, may be taken as 27,500 ft.-lbs.

We have already seen that the mechanical equivalent of heat is 778 ft.-lbs. per British thermal unit (B.T.U. or heat unit, viz., the quantity of heat required to raise 1 lb. of pure water 1° Fahr., or, more exactly, from 39·1° to 40·1°), therefore:—

$$\frac{27500}{778} = 35\cdot3 \text{ B.T.U.}$$

This, however, as above mentioned, is on the assumption that compression, cooling, and expansion all take place in the same

cylinder and without loss or accession of heat to the exterior, an impossible arrangement in practice, and if the air be compressed in one cylinder and passed into other cylinders against pressure for cooling and expansion, as it would be in an actual working arrangement, another 122,000 ft.-lbs. would be consumed for the discharge of the air against pressure, whilst there would be a recovery of 80,000 ft.-lbs. due to the expansion of the compressed air behind a piston, and we have, therefore, 27,500 ft.-lbs. + 122,000 ft.-lbs. = 149,500 ft.-lbs. - 80,000 ft.-lbs. = 69,500 ft.-lbs. as the expenditure of power required to cool 100 cub. ft. of air 50° with cooling or condensing water at a temperature of 80° Fahr.

The principles involved in the process are very simple, as will be readily seen from the above. The main point is that the temperature of the substance or agent to be cooled must be raised above that at which the water available for condensing purposes happens to be; the exact amount of this additional temperature must be regulated by the temperature at which it is required that the medium or agent should be on leaving the expansion cylinder. Another absolute necessity is the provision of a suitable cooling medium, such as water, which will take up the heat given off from the medium or agent to be cooled, which cooling or condensing water can be run to waste, or cooled for further use for the same purpose.

Finally it must be borne in mind that all substances contain, more or less, heat; and that as heat cannot be created, nor yet can it be destroyed, a body can only be reduced in temperature by the transference of more or less of its heat to another body.

The abstraction of heat, therefore, from one body and its transfer to another, called the refrigerating or cooling agent, is naturally the main function of refrigerating and ice-making apparatus, and in order to ensure continuity of action, the refrigerating agent—the temperature of which must necessarily be lower than that of the substance upon which it is desired to act—must be either periodically renewed, or suitable means must be provided for the removal therefrom of the heat extracted or abstracted from the latter. That is to say, a continuously working machine comprises a heat-abstracting apparatus, and suitable means for automatically renewing at the requisite intervals the cooling agent or medium, or for the removal from the latter of the heat extracted from the body it is desired to cool, so as to enable it to be used over and over again in a continuous cycle.

In short a refrigerating machine, in a few words, may be described as a heat pump.

The various inventions for refrigerating and ice-making that are now in use can be conveniently classified for the present purpose under the following five principal heads, viz.:—

First, those wherein the more or less rapid dissolution or liquefaction of a solid is utilised to abstract heat. This is, strictly speaking, more a chemical process.

Second, those wherein the abstraction of heat is effected by the evaporation of a portion of the liquid to be cooled, the process being assisted by an air-pump. This is known as the vacuum system.

Third, those wherein the abstraction of heat is effected by the evaporation of a separate refrigerating agent of a more or less volatile nature, which agent is subsequently restored to its original physical condition by mechanical compression and cooling. This is called the compression system.

Fourth, those wherein the abstraction of heat is effected by the evaporation of a separate refrigerating agent of more or less volatile nature under the direct action of heat, which agent again enters into solution with a liquid. This is termed the absorption system.

Fifth, those wherein air or other gas is first compressed, then cooled, and afterwards permitted to expand whilst doing work, or practically by first applying heat, so as to ultimately produce cold. These are usually designated as cold-air machines.

CHAPTER III

THE LIQUEFACTION PROCESS

Use of, by the Ancients—Various Machines Operating on the—General Laws Governing Production of Cold by—Principal Freezing Mixtures.

LIQUEFACTION, or the utilisation of the more or less rapid dissolution of a solid to abstract heat, is one of the most ancient methods employed for artificial cooling. The reduction of temperature of water and other liquids by the melting of saltpetre is said to have been known in India at a very remote period, and it is on record that one Blasius Villafanica, a physician of Rome, utilised it for this purpose as early as 1550. The Romans are said to have cooled wine by immersing the bottle containing the latter in a second vessel filled with cold water into which saltpetre was gradually thrown, whilst at the same time the bottle was rotated rapidly. Freezing water by the use of a mixture of snow or powdered ice and saltpetre was mentioned by Latinus Tancredus, of Naples, in 1607, and wine by means of snow and common salt by Santorio in 1626. This was also, in all probability, the method employed by the Esthonian tribe for producing artificial cold, and freezing the dead, and liquids, as mentioned by Orosius about A.D. 400.

To this class belong the numerous ordinary and well-known machines and apparatus employed for icing creams, lemonades, &c., which usually consist of a tub constructed of wood into which a vessel containing the substance to be cooled or frozen is placed, and is surrounded by a frigorific agent, such as a mixture of pounded ice or snow and chloride of sodium; or a combination of certain chemicals may be substituted for the former.

This method is also used on a more extensive scale for ice-making and cooling, but although ice can be produced on a commercial scale with improved apparatus, it is still more expensive than strictly mechanical methods. The best among the many forms of apparatus for making ice on this principle are probably those of Toselli and Siemens.

In Toselli's machine the frigorific agent consists of a mixture of ammonium nitrate and water, which produces a reduction of temperature of about 40° Fahr. The apparatus requisite is one of extreme simplicity, consisting merely of a vessel in which the solution of the salt is effected, and a can wherein are placed a number of moulds of different sizes, circular in cross section, and formed with a slight taper. These moulds, previously filled with water, are inserted in the freezing mixture, and a thin film of ice is formed round their edges in a few minutes; these slightly tapered tubes of ice are then withdrawn from the moulds, and placed one inside the other, thus forming a small stick of ice. The relative dimensions of the moulds are, of course, such as to form the ice tubes suitably proportioned to admit of the above operation.

In Siemens' apparatus calcium chloride is employed as the frigorific agent. The dissolution of this salt in water produces a reduction of temperature of only about 30° Fahr., and to admit of this reduction being sufficient to produce ice with water at an initial temperature of 65° Fahr., a heat interchanger is provided, wherein the spent liquor, which is at a temperature of about 30° Fahr., is employed to cool the water before it is mixed with the salt. It will thus be seen that there will be a gain in reduction of temperature equivalent to the amount of this cooling action. The salt can be recovered by evaporation, and employed over and over again. This apparatus is stated to have worked well, producing ice on a large scale in a satisfactory manner, but owing to its being on the whole found to be inferior, and more costly than purely mechanical methods of producing ice, it has never come into general use.

In an American machine, wherein ammonium nitrate is likewise employed as the frigorific agent, cylindrical receptacles fitting one within the other, so as to leave annular spaces or clearances, are provided. The water to be frozen is placed in the centre, the frigorific agent in the annular spaces or clearances, so that the first or outermost acts to cool the second, the second the third, and the third the fourth, and so on, the cold being intensified at the centre in accordance with the number of the annular spaces containing the frigorific agent. The series of cylindrical vessels or receptacles are arranged in a wooden outer casing so mounted as to be capable of being slowly revolved, and thereby promoting the more rapid dissolution of the salt. This apparatus is analogous to that employed many years ago on a small scale for laboratory experiments by Walker, and by means of which he succeeded in sinking the spirit to -91° Fahr.

When any of the above methods are employed for refrigerating purposes, brine, previously cooled in the apparatus, is circulated in the usual manner through a system of cooling pipes.

The general law governing the production of cold by frigorific mixtures is, that during the liquefaction of a solid, a certain amount of heat not indicated by, or sensible to, the thermometer is absorbed, which heat is abstracted from any surrounding bodies. The absorption of heat, consequently the production of cold, in the environing bodies is the more marked in proportion as the solid is more suddenly or rapidly liquefied.

The following observations on frigorific mixtures are extracted from a paper* on "Refrigerating and Ice-making Machinery and Appliances," by Mr T. B. Lightfoot, C.E., M.I.C.E., who is a well-known authority upon the subject: "When a substance changes its physical state, and passes from the solid to the liquid form, the force of cohesion is overcome by the energy in the form of heat. The effect may be produced without change in sensible temperature, if the heat be absorbed at the same rate as it is supplied from without. Thus, as is well known, the temperature of melting ice remains constant at 32° Fahr., and any increase or decrease in the heat supplied merely hastens or retards the rate of melting without affecting the temperature. Mixtures of certain salts with water or acids, and of some salts with ice, which form liquids whose freezing points are below the original temperatures of the mixtures, do not, however, behave in this way; for under ordinary circumstances the tendency to pass into the liquid form is so strong, that the heat is absorbed at a greater rate than it can be supplied from without. The store of heat of the melting substances themselves is therefore drawn upon, and the temperature consequently falls until a balance is set up between the rate of melting and the rate at which heat is supplied from outside. This is what takes place with ordinary freezing mixtures. The amount of the depression in temperature appears to depend to some extent on the state or hydration of the salt, and the percentage of it in the mixture. Almost the only salts used are those of certain alkalies, few others possessing the requisite solubility at low temperatures."

It may be here observed that this method of refrigeration is now only interesting from an historical point of view, and is not suitable for modern conditions, so far as commercial undertakings are concerned. Practically, therefore, the process is now only employed for domestic purposes and in laboratories.

* *Proceedings, Institution of Mechanical Engineers*, 1886, p. 201.

TABLE OF PRINCIPAL FREEZING MIXTURES.

| Composition of Freezing Mixtures (Materials previously cooled). | Reduction of Temperature in Degrees Fahr. | | Amount of Fall in Degrees Fahr. |
|--|---|-----|---------------------------------|
| | From | To | |
| Snow or pounded ice, 2 parts ; muriate of soda, 1 part - | ... | -5 | ... |
| Snow, 5 ; muriate of sodium, 2 ; muriate of ammonia, 1 - | ... | -12 | ... |
| Snow, 24 ; muriate of sodium, 10 ; muriate of ammonia, 5 ; nitrate of potash, 5 - | ... | -18 | ... |
| Snow, 12 ; muriate of sodium, 5 ; nitrate of ammonia, 5 - | ... | -25 | ... |
| Snow, 4 ; muriate of lime, 5 - | +32 | -40 | 72 |
| Snow, 1 ; chloride of sodium or common salt, 1 - | +32 | 0 | 32 |
| Snow, 2 ; muriate of lime crystallised, 3 - | +32 | -50 | 82 |
| Snow, 3 ; dilute sulphuric acid, 2 - | +32 | -23 | 55 |
| Snow, 3 ; hydrochloric acid, 5 - | +32 | -27 | 59 |
| Snow, 7 ; dilute nitric acid, 4 - | +32 | -30 | 62 |
| Snow, 8 ; chloride of calcium, 5 - | +32 | -40 | 72 |
| Snow, 2 ; chloride of calcium crystallised, 3 - | +32 | -50 | 82 |
| Snow, 3 ; potassium, 4 - | +32 | -51 | 83 |
| Snow, 2 ; chloride of sodium, 1 - | ... | -5 | ... |
| Snow, 5 ; chloride of sodium, 2 ; chloride of ammonia, 1 - | ... | -12 | ... |
| Snow, 14 ; chloride of sodium, 10 ; chloride of ammonia, 5 ; nitrate of potassium, 5 - | ... | -18 | ... |
| Snow, 12 ; chloride of sodium, 5 ; nitrate of ammonia, 5 - | ... | -25 | ... |
| Snow, 2 ; dilute sulphuric acid, 1 ; dilute nitric acid, 1 - | -10 | -56 | 46 |
| Snow, 12 ; common salt, 5 ; nitrate of ammonia, 5 - | -18 | -25 | 7 |
| Snow 1 ; muriate of lime, 3 - | -40 | -73 | 33 |
| Snow, 8 ; dilute sulphuric acid, 10 - | -68 | -91 | 23 |
| Chloride of ammonia, 5 ; nitrate of potassium, 5 ; water, 16 - | +50 | +4 | 46 |
| Nitrate of ammonia, 1 ; water, 1 - | +50 | +4 | 46 |
| Chloride of ammonia, 5 ; nitrate of potassium, 5 ; sulphate of sodium, 8 ; water, 16 - | +50 | +4 | 46 |
| Sulphate of sodium, 5 ; dilute sulphuric acid, 4 - | +50 | +3 | 47 |
| Sulphate of sodium, 8 ; hydrochloric acid, 9 - | +50 | 0 | 50 |
| Nitrate of sodium, 3 ; dilute nitric acid, 2 - | +50 | -3 | 53 |
| Nitrate of ammonia, 1 ; carbonate of sodium, 1 ; water, 1 - | +50 | -7 | 57 |
| Sulphate of sodium, 6 ; chloride of ammonia, 4 ; nitrate of potassium, 2 ; dilute nitric acid, 4 - | +50 | -10 | 60 |
| Phosphate of sodium, 9 ; dilute nitric acid, 4 - | +50 | -12 | 62 |
| Sulphate of sodium, 6 ; nitrate of ammonia, 5 ; dilute nitric acid, 4 - | +50 | -14 | 64 |
| Phosphate of sodium, 5 ; nitrate of ammonia, 3 ; dilute nitric acid, 4 - | 0 | -34 | 34 |
| Phosphate of sodium, 3 ; nitrate of ammonia, 2 ; dilute nitric acid, 4 - | -34 | -50 | 16 |
| Snow, 3 ; muriate of lime, 4 - | +20 | -48 | 68 |
| Snow, 1 ; muriate of lime crystallised, 2 - | 0 | -66 | 66 |
| Snow, 2 ; muriate of lime, 3 - | -15 | -68 | 53 |
| Snow, 8 ; dilute sulphuric acid, 3 ; dilute nitric acid, 3 - | -10 | -56 | 46 |
| Snow, 3 ; dilute nitric acid, 2 - | 0 | -46 | 46 |
| Snow, 1 ; dilute sulphuric acid, 1 - | -20 | -60 | 40 |
| Snow, 2 ; muriate of lime crystallised, 3 - | -40 | -73 | 33 |
| Snow, 8 ; dilute sulphuric acid, 10 - | -68 | -91 | 23 |

CHAPTER IV

THE VACUUM PROCESS

Principles of—First Machine Working on—More Recent Types of Machines Working on.

THE abstraction of heat by the evaporation of a portion of the liquid to be cooled, the process being assisted by an air-pump, or the vacuum process, includes all such machines as operate to extract heat by the evaporation or vaporisation of a portion of the water or other liquid to be cooled or frozen.

The cooling of liquids on this principle depends upon the conversion of the sensible heat into latent heat during evaporation, and, in its most primitive form, its use is almost co-existent with that of the world, having been commonly employed for refrigerating purposes in all ages. It is obvious, however, that as a portion of the liquid to be cooled is permitted to go to waste, it can be only profitably applied direct to liquids of little or no value, such as water.

A common example of this method in its crudest form is found in the ancient plan, so universally adopted in hot climates, of cooling water by the evaporation of a portion of the contents of a porous jar or vessel from the outer surface thereof, by hanging the vessel in a position where it will be subjected to either a natural or an artificial draught.

It is stated that the practice of procuring ice by exposing water to the night air in shallow porous vessels has been practised in India during the cool season from the remotest ages. The vessels are placed on a bed of straw, cornstalks, or megass (crushed cane stalks) in shallow excavations made preferably in an exposed situation on an extensive plain, being filled with water to be congealed or frozen, and in the morning, provided the night be clear, are found covered with thin crusts of ice.

This process is also said to have been practised, both in France and in this country, in the latter part of the last century, with perfect success, so far at least as the production of ice was concerned, but it failed commercially by reason of the large expenses entailed.

The first machine on the vacuum principle for the production of artificial ice by the conversion of sensible into latent heat by evaporation, of which there is any record, was that invented by Dr Cullen in 1755, who in that year made the discovery that the evaporation of water could be facilitated by the removal of the atmospheric pressure by means of an air-pump, to such a degree as to enable him to freeze water even in summer.

This apparatus was the parent of all those subsequently designed for cooling and congealing liquids by their own evaporation in vacuo, that is to say, wherein the vapour is drawn off from the partial vacuum

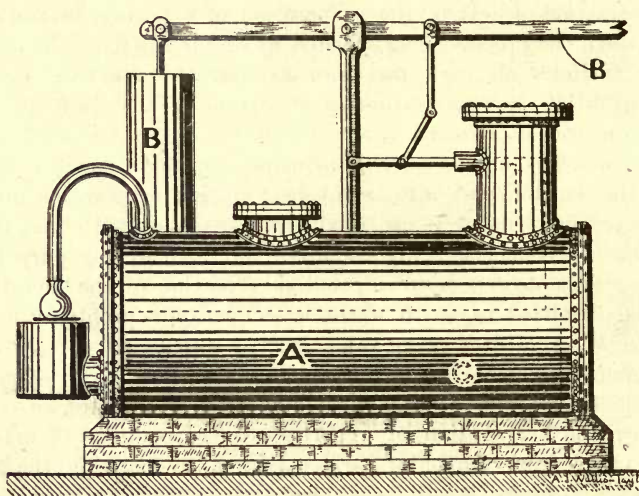

Fig. 4.—Carré's Sulphuric Acid Vacuum Freezing Machine. Vertical Section.

wherein it is formed, and is condensed in another partial vacuum with or without the help of absorbents, and is expelled by pressure.

In 1777, Nairne found that, by the introduction of sulphuric acid into a receiver for the exhaust, the aqueous vapour could be absorbed from the rarefied air and the latter dried; and by taking advantage of this discovery he was enabled, in 1810, to construct an apparatus wherein he got rid of the vapour that rose from the water, and thus prevented it from forming a permanent atmosphere, and hindering the continuity of the operation.

Further attempts were made by Leslie (1810), Vallance (1824), Kingsford (1825), and others, but without any much greater success

attending their efforts, Edmond Carré's sulphuric acid freezing machine being the first to be commercially successful.

This apparatus, acting to refrigerate by evaporation and rarefaction, and which was adapted to produce the *cafés frappés* commonly used in Parisian cafés and restaurants, consists, as shown in Fig. 4, of a cylindrical vessel, A, intended to contain the charge of concentrated sulphuric acid; an air-pump, B, so arranged that it can be connected to the mouth of the carafe, and of an agitator, C, which is so coupled to the air-pump lever that it will be operated during the working of the pump in such a manner as to keep the sulphuric acid in the cylindrical vessel A continually in motion.

The machine of course only operates intermittingly, but the large body of sulphuric acid used in the vessel A prevents a rapid loss of absorptive power taking place through dilution, and the agitation obviates the formation of a more diluted stratum on the surface, which would be highly detrimental to the proper working of the apparatus.

The chief drawback to this machine, besides its intermissive action, is the difficulty experienced in maintaining the pump in good working order, and the various joints all perfectly gas-tight.

Franz Windhausen patented in 1878 a compound vacuum-pump designed to produce ice directly from water without using sulphuric acid; and likewise a modified arrangement wherein sulphuric acid could be employed. In this latter apparatus the sulphuric acid is cooled by water whilst absorbing the vapour, and is subsequently concentrated, when it becomes over-diluted, thus obviating the necessity for the insertion of a fresh supply of acid.

An improved form of this machine constructed in 1881, nominally capable of producing from 12 to 15 tons of ice per twenty-four hours, and which was first put up at the Aylesbury Dairy, Bayswater, London, and afterwards removed to Brompton, was fully described at the time in a paper * written by Dr Hopkinson.

The ice-forming vessels or moulds, which are six in number, are constructed of cast iron, circular in transverse section, and slightly tapered. These cans, moulds, or cases moreover are steam-jacketed, so as to admit of the ice being melted or thawed off and readily disengaged therefrom, and are provided at their lower ends with hinged doors, which, when closed, form fluid-tight joints.

The sulphuric acid is contained in a long cylindrical vessel wherein rotating agitators maintain the acid in continual motion during the operation of the apparatus, and the cylindrical vessel is water-jacketed

* *Journal of the Society of Arts*, 1882, vol. xxxi., p. 20.

so as to carry off the greater portion of the heat that becomes liberated during the absorption of the vapour.

The sulphuric acid cylinder or vessel communicates with the upper parts of the ice-forming vessels or moulds, and with the vacuum-pump, which latter has two cylinders, viz., a large double-acting one and a small single-acting one.

The water is admitted to the moulds through nozzles at a regulated rate, the fine streams offering an extended surface for evaporation, and becoming instantly congealed into ice globules or particles which, falling into the bottoms of the moulds, are frozen, together with the water that collects there.

In the operation of the apparatus the air, and any vapour that may pass over from the sulphuric acid cylinder or vessel, are drawn into the large pump-cylinder, by which they are slightly compressed and passed on into the condenser, wherein a portion of the vapour is condensed by cold water, the rest, together with the air, entering the second or smaller pump-cylinder, where they are compressed up to the tension of the atmosphere and discharged. This pump, it is stated, admits of a vacuum of half a millimetre of mercury being constantly maintained; $2\frac{1}{2}$ mm., however, being as low a vacuum as it is found necessary to have during actual work.

By the employment of a compound pump with an intermediate condenser, and performing the compression in two distinct stages, the losses that would otherwise occur from the clearance spaces in the large pump are greatly reduced.

The concentrator for the diluted sulphuric acid consists in a lead-lined vessel or receptacle fitted with a steam-heated coil of lead piping and connected with an ordinary air-pump. The acid is transferred from one vessel to the other by atmospheric pressure, and the diluted or weak acid, which is at a comparatively low temperature, is heated on its way to the concentrator in an interchanger, by the strong concentrated acid returning from the latter.

The ice produced by this machine, like that of all those on the vacuum principle acting direct, is in an opaque and porous condition; and the avoidance of this defect, and the production of clear transparent crystal ice by freezing it in moulds plunged in brine previously cooled by evaporation in a vacuum, would render the process too expensive to be commercially successful.

The total amount of water that is used in working is from 10 to 12 tons per ton of ice, and the fuel 180 lbs. of coal to each ton of ice produced; the latter is employed in raising the requisite supply of

steam for driving the pumps, and heating the coil in the sulphuric acid evaporator.

Fig. 5 is a vertical central section partly in elevation showing Langé's improved pump for exhausting the air from the absorber of a vacuum machine. As will be seen from the drawing, three pistons, A, B, and C, are employed, placed in line one above the other, and working in three superimposed cylinders. The valves are so arranged that each of the uppermost cylinders draws from the one below, and they are sealed with oil, which latter constantly circulates through the pump. The mixed oil and air, on leaving the top or uppermost

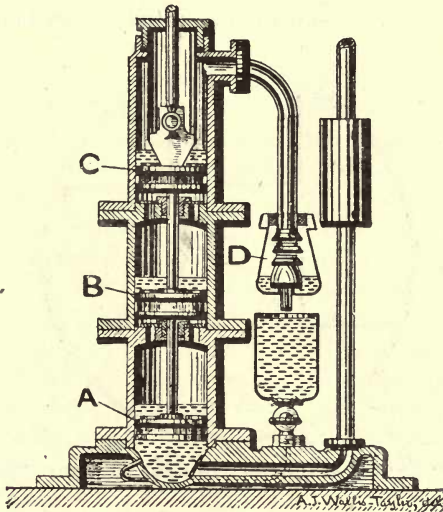

Fig. 5.—Langé's Exhaust Pump for Vacuum Freezing Machine. Vertical Section.

cylinder, is discharged into a separator D, the air being permitted to escape into the atmosphere, and the oil passing into a receptacle from which it can be returned to the pump when required.

The vacuum apparatus for the refrigeration of a liquid by its partial evaporation, for which James Harrison took out a patent in 1878, is designed to produce opaque ice at a very low cost (about one shilling per ton), by reducing the fuel consumption, which, as already mentioned, is the chief item of expense. This is proposed to be effected by getting rid of the bulk of the friction engendered in the usual vacuum and air pumps, and also by a saving of the fuel expended in concentrating the weak or diluted sulphuric acid in the previously

described apparatus. The main feature of Harrison's invention is the process of refrigerating by the evaporation of the liquid to be cooled or congealed, by carrying its vapour under a head of neutral non-evaporable liquid, condensing the compressed vapour at the ordinary temperature, and removing the resulting liquid and air by a pump.

One form of his apparatus consists in a rotating pump or cylinder which seems to provide a ready means of exhausting large volumes of low tension vapour, without the expense of the labour entailed in maintaining ordinary piston packings in an effective condition, and the great loss through friction therefrom. This device consists, as will be seen from the sectional diagrammatical view, Fig. 6, of an iron cylinder, rotatably mounted horizontally upon hollow or tubular

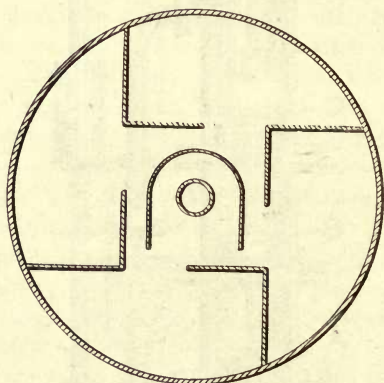

Fig. 6.—Diagram illustrating Harrison's Rotating Exhaust Pump or Cylinder.

shafts or axles, and divided internally into different compartments by longitudinal partitions of an L shape in transverse section. This cylinder is connected through one of the hollow shafts or axles with the refrigerating or ice-making vessels or moulds, which may be of any convenient form, and it is partly filled with oil or other liquid, which latter must invariably be either non-evaporable or one which is only vaporisable at a temperature greatly in excess of that at which the refrigerating liquid can be vaporised, and it must, moreover, be perfectly neutral chemically to the vapour with which it will be brought into contact when the machine is at work.

The operation of the apparatus is as follows, viz. :—The cylinder rotates upon one of the fixed hollow axles, through which the vapour or gas to be compressed is delivered from the refrigerator or ice-making

vessels, and the longitudinal partitions or compartments moving round with their apertures downwards carry with them charges of the vapour, and compress them to a degree varying in accordance with the depth to which they dip below the surface of the liquid. After attaining the lowest position the compressed vapour is liberated, and rises into a fixed hood or inverted channel, situated centrally and communicating with the other hollow shaft or axle, which is placed at the other side of the cylinder, through which it passes to a surface condenser. In this surface condenser the compressed vapour is partially condensed, both by direct cooling action and also by the evaporation of water flowing over the surface, and the condensation water, together with any air present, is then compressed to the atmospheric tension and discharged.

Several modifications are also described, viz. :—First, a series of buckets attached to endless chains dipping into a reservoir of the compressing liquid, and delivering the compressed gas or vapour into a reservoir. Secondly, a gasometer-shaped vessel, rising and falling in an annular space filled with a non-evaporable neutral liquid. The vessel, on being lifted, becoming filled with the air or vapour, and on being depressed delivering it under a head of liquid. Thirdly, a tapering archimedean screw working in a reservoir of non-evaporable neutral liquid by which the vapour is taken in at the larger upper orifices, and is discharged, compressed, and liquefied at the lower or smaller end. Fourthly, pumps with actuated valves and with arrangements for complete expulsion of air and vapour. And finally, fifthly, fans working in the air or vapour, and forcing it from one compartment into another, or exhausting it and forcing it into the atmosphere.

A patent was obtained by Blyth and Southby some years back for a vacuum refrigerating machine of great simplicity of design. The main feature of their apparatus consists in the provision of two pumps, viz., a large main pump and a small auxiliary one, the former being heated by means of a steam jacket or otherwise.

The large, single-acting, steam-jacketed vapour pump is driven by a crank, which is situated beneath, and is enclosed in a suitable cylindrical casing or chamber, having at one side a door or cover, admitting of access thereto, and so arranged that when closed it forms a gas-tight joint. The crank is driven by belt gearing from any suitable source of motive power, and the pulley for the latter is fixed upon the end of a shaft or spindle passing through a stuffing box provided upon the opposite side, or wall, of the crank chamber,

to that fitted with the door or cover. A heavy balanced fly-wheel is also mounted upon the crankshaft, and is enclosed within this chamber, which, as above mentioned, is made perfectly fluid tight.

The ice box is fitted with an automatic feeding arrangement for filling the ice can or case with water, which mechanism is operated by an eccentric upon the crankshaft, and the box is connected with the pump through a pipe governed by a stop-cock or valve, a similar cock or valve being also fitted in the pipe leading to the cooling vessel, and another suitable valve in the vapour exit to the condenser.

A double-acting air or ejector pump worked off the eccentric is moreover provided for removing the air from the interior of the machine, and a vacuum gauge for ascertaining the degree of vacuum produced.

The operation of the machine is as follows, viz. :—Any air that may be contained within the large pump cylinder is first pumped or drawn off by the small air or ejector pump, thereby producing a vacuum which is filled by vapour from the water to be frozen or cooled. The large single-acting pump, which draws the vapour from the water through a suction valve situated in the piston, compresses this vapour and delivers it through the outlet or discharge valve to the condenser, where it is condensed by water in the usual manner, is removed by the small air or ejector pump, together with any air that may have passed into the machine through leakage, and is discharged into the atmosphere. The vapour is prevented from condensing in the cylinder by the steam jacket, which maintains the temperature of the cylinder above that at which the vapour will condense into water. Were this not the case, and were the vapour permitted to condense in the cylinder, the quantity to be discharged would be so small as not to be capable of being forced through the delivery or outlet valve.

When starting the machine, communication between both ends of the vapour pump cylinder can be kept open for any requisite length of time during the first portion of the delivery stroke, so as to permit the air to return to the underside of the piston, and thereby lessen and regulate the expenditure of power required in getting up the vacuum. This is effected by means of a bye-pass and valve, which can be opened at starting, and kept open for about nine-tenths of the piston stroke, being closed gradually as soon as the vacuum becomes more perfect, and altogether as soon as all the air has been got rid of. The average pressure upon the piston is light, not exceeding about one-sixth of a pound.

In all the above arrangements, a portion of the refrigerating agent

itself, together with the heat it has absorbed, is rejected, consequently water, as the only one sufficiently inexpensive, is invariably employed. Water has a boiling point of 212° Fahr. at atmospheric pressure, a latent heat of vapour of 966.6 and a tension of vapour of 0.623, and having so high a boiling point it requires a vacuum of .089 lb. per square inch to boil at a temperature of 32° Fahr., and consequently a vacuum at the very least as high as this must be maintained to produce ice by the vacuum process.

An improved form of Carré's sulphuric acid freezing machine, adapted to be operated by hand power, is manufactured in this country by the Pulsometer Engineering Co., Ltd. London.

This machine is made in four sizes. The two smallest sizes only admit of very small quantities of ice being made, but with the two larger sizes, upwards of 7 lbs., and from 20 to 30 lbs. of ice can be made respectively in a day, and with the largest-sized machine about 80 lbs. per day.

It is claimed that the acid, after use in these machines, is especially suitable for use in soda-water making machines, as having been diluted slowly it has lost the heat generated by the mixture of acid and water, and is consequently ready for immediate service.

CHAPTER V

THE COMPRESSION PROCESS OR SYSTEM

Early History of—Principles of—Cycle of Operations obligatory in—Improvements in—Ether Machines—Sulphurous Acid Machines—Carbonic Acid Machines.

So far the refrigeration has been effected by evaporation, the air gaining access under natural conditions, or by an artificial draught, or the evaporation has been accelerated by reducing the atmospheric pressure, the latter operation being next still further facilitated and rendered practically continuous by providing for the absorption of the vapour given off or evolved by means of an absorbent, such as sulphuric acid.

More volatile liquids, however, are employed as agents, such as, for instance, alcohol, sulphurous and carbonic acids, bisulphide of carbon, gasoline, ether, methylic and sulphuric ether, carbon bisulphide, methyl chloride, ethylene, anhydrous ammonia, Picteau fluid, &c.

In the year 1755, Dr Cullen found that, by removing the atmospheric pressure, ether and other liquids which boil at low temperatures would evaporate at temperatures below freezing point, with sufficient rapidity to congeal water brought into contact with the exterior surfaces of the vessels or receptacles wherein they were contained.

In a refrigerating and ice-making apparatus invented by Jacob Perkins about the year 1834, compression was first introduced, the volatile liquid used, according to Sir Frederick Bramwell, being one derived from the destructive distillation of caoutchouc. This invention of Perkins' is the origin from which has sprung all those machines operating upon the compression principle; that is to say, by the abstraction of heat by the evaporation of a separate refrigerating agent of a more or less volatile nature, which agent is subsequently restored to its original physical condition by mechanical compression and cooling.

Perkins' apparatus is shown in Fig. 7 in side elevation, partly in vertical section, and consists simply, as will be seen from the illustration, in a jacketed pan, A, clothed externally with non-conducting

material, and a pump, B, connected to the upper part of the jacket, and to the first or uppermost convolution of a coil or worm fitted in a tank or vessel, c, wherein cooling water can be freely circulated, and the last or lowermost convolution of which coil or worm is connected to the lower part of the jacket. The water to be frozen is placed in the jacketed pan, the space or clearance between the latter and the jacket being partially filled with the distillate from caoutchouc, or the ether, or other volatile liquid intended to form the refrigerating agent. The vapour given off or evolved from the volatile liquid contained in this space or clearance is drawn off from the top by the pump B, and is delivered compressed to the water-cooled worm or coil, which is shown by dotted lines in the tank c, wherein it is again liquefied and returned from the bottom of the latter to the lower part of the space or clearance. The complete cycle of operations is thus continuous,

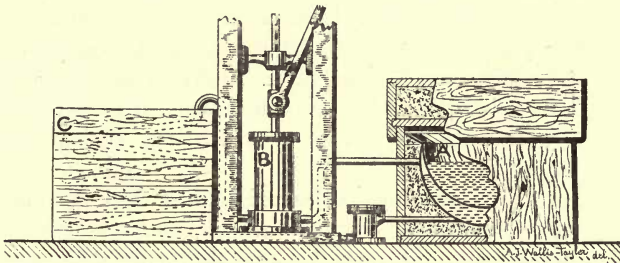

Fig. 7.—Perkins' Early Type of Compression Machine.

and the only loss of the volatile liquid used as a refrigerating agent that is possible is that which may take place through leakage.

The system of absorbing heat and thus producing cold, partly by the expansion and vaporisation or gasifying, and subsequent liquefaction, and partly by compression and cooling, is in accordance with the well-known law of physics, viz., that all gases during the process of passing from a liquid to a gaseous state are bound to absorb a certain amount of heat, and whilst returning from a gaseous to a liquid state to give up or throw off the same amount of heat.

Whatever the refrigerating or heat-absorbing agent that may be used, the following cycle of operations is obligatory in all machines working upon this principle, viz. :—

First, compression, that is the refrigerating or heat-absorbing agent in gaseous form, is subjected to a pressure sufficient to reduce it to a liquid form, this pressure varying with the nature of the agent

and the temperature of the condensing water. During this compression, a degree of heat is developed in accordance with the amount of pressure to which the gas is subjected, or to the volume to which it has to be reduced relatively to that of the gas, in order to produce liquefaction. This heat is carried off by means of condensing or cooling water.

Second, condensation, during which process the heat developed during the above-described compression of the gas is carried away by forcing the latter through water-cooled pipes, the heat being transferred to the cooling water. At this point the gas is ready to assume the liquid form, in doing which an additional amount of heat is given off to the water.

Third, expansion, during which the liquefied gas is admitted to series or coils of pipes, and being suddenly relieved of pressure, instantly flashes or expands into a gaseous form; in doing which, according to the above-mentioned law of physics, it is forced to absorb or take up a quantity of heat which it renders latent, and which it draws from the surrounding objects, viz., firstly, of course, the pipes or coil wherein it is confined, and secondly, such substances as may be brought in contact with the latter, and which it is desired to cool, as air, water, brine, &c.

The amount of heat thus abstracted or absorbed is equal to that previously given up to the cooling water in the condenser, the gas being then ready for compression, &c., and the cycle of operations can thus be repeated *ad infinitum*.

These three operations being essential, all machines of this class, however much they may differ in more or less important points of detail, must perforce consist of the three main parts shown in the diagram, Fig. 8, viz. :—

First, a compressor, A, wherein the gas is compressed in some suitable and convenient manner.

Second, a condensing side, B, wherein the gas circulates through water-cooled pipes or coils or their equivalent, gives off its heat, and liquefaction takes place.

Third, an expansion side, C, consisting of pipes or coils, or other space, wherein the gas can re-expand and perform its work of cooling or refrigerating, by abstracting heat in the above-described manner from the surrounding objects. D is a regulating valve, E is the low pressure gauge, and F is the high pressure gauge.

It will be seen that the heat only that has been acquired by the refrigerating agent is rejected, the latter being used over and over

again, the only loss, therefore, is that sustained through accidental leakages.

Such liquids only, however, are capable of being used as refrigerating agents as possess vapours capable of being liquefied under pressure at ordinary temperatures. Hence, owing to the latter operation being an absolute essential, it is generally known as the compression process.

The next attempt at improvement in these machines was made by Professor Twining, who obtained a patent for his invention in this country in 1850, and in the United States in 1853. His apparatus comprises an exhaust or expansion vessel, a pump, and a condenser. The water to be frozen is placed in chambers or cells situated between thin metal pipes, plates, or partitions, through which circulates the

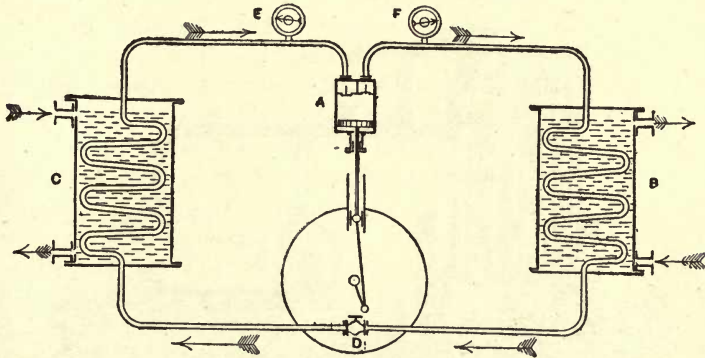

Fig. 8.—Diagram Illustrating the Operation of a Refrigerating Machine on the Compression Principle.

vapour evolved from a suitable volatile liquid, such as ether, sulphide of carbon, &c., which vapour is drawn off by an air-pump, compressed, condensed in a coil or worm, cooled by water, and is then returned to the reservoir, in which it is once more vaporised in a manner substantially similar to that of Perkins'. In fact, as already intimated, all machines of this class are bound to operate upon the same principle as that of the latter inventor, and can only differ therefrom in details of construction of more or less importance

It is stated that a machine of Twining's, of a capacity designed to produce 2,000 lbs. of ice in twenty-four hours, was in operation in 1855 in Cleveland, Ohio; and that, although working under somewhat serious disadvantages, it did actually produce 1,600 lbs. of ice per

twenty-four hours in a tolerably satisfactory manner, and was in use off and on for about three years.

Another machine, which comprises certain further improvements on Perkins' apparatus, was invented and patented by James Harrison in the year 1856.

The novel feature claimed especially, in Harrison's compression machine, is the evaporation of volatile liquids in vacuo, and the reduction to a liquid form in a separate vessel by pressure. The essential parts of his apparatus consist of three vessels connected by tubes, a vacuum being established throughout the apparatus, and the air being expelled by the vapour of ether, ammonia, or other volatile liquid. The first vessel is charged with the volatile liquid; the second vessel contains a pumping and compressing apparatus, by means of which

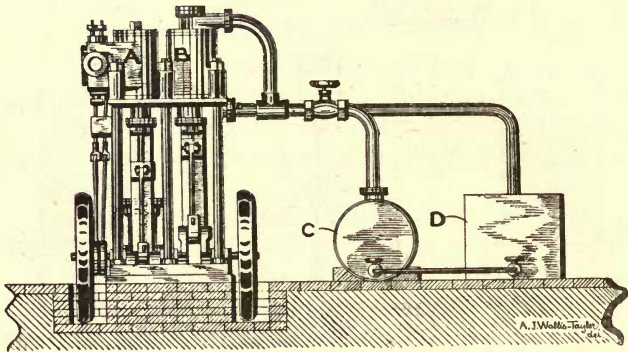

Fig. 9.—Harrison's Ether Compression Machine.

the vapour is withdrawn from the first vessel and forced into a third; and the third or last vessel is immersed in water or kept moist, so that the heat generated by the compression and liquefaction of the vapour may be carried off. The resulting liquid passes into the first vessel to be again evaporated under diminished pressure, and again withdrawn, compressed, liquefied, and returned, the process being capable of indefinite prolongation, until the apparatus be either injured or becomes worn out.

The general arrangement of an improved Harrison machine constructed by Siebe Gorman & Co., is shown in side elevation in Fig. 9, wherein A is the steam-engine cylinder; B is the pump or compression cylinder, which is kept cool by a suitable water jacket; C is the refrigerator, which consists of a copper cylinder, fitted with sets of

copper tubes arranged horizontally ; d is the ether condenser, which is composed of sets of copper tubes also arranged horizontally in a wooden tank or casing, and cooled by a circulation of water.

Suitable connections are provided between the refrigerator c, pump b, and condenser d.

The refrigerating agent employed in this apparatus is sulphuric ether, which is the result of the action of sulphuric acid upon vinous alcohol, and which has a specific gravity of 0·720, a latent heat of vaporisation of 165, a specific gravity of vapour of 2·24 as compared with air, and the boiling point of which is 96° Fahr. at atmospheric tension.

The liquid sulphuric ether is delivered from the condenser d to the refrigerator c, through a pipe fitted with a stop-cock, by means of which the amount admitted can be nicely adjusted to the capacity of the pump b. The weight of ether capable of being drawn off by the pump b is dependent upon the pressure at which evaporation takes place, as it is perfectly obvious that the denser the vapour, the greater the weight drawn off at each stroke of the pump.

In order to ensure this apparatus working up to its fullest capacity the boiling point of the sulphuric ether must be so regulated as to impart the exact reduction of temperature desired, consequently the pressure at which evaporation is caused to take place depends upon the degree of temperature to which it is required to lower the brine.

The amount of water required to be passed through the ether condenser d, for cooling purposes, naturally varies in different climates, and in accordance with the season of the year ; in this country it is stated to be about 150 gals. per hour for each ton of ice produced per twenty-four hours. The liquefaction of the vapour is said to take place with cooling water at the temperature usually obtainable here at a pressure of some 3 lbs. per square inch above that of the atmosphere ; in a hot climate, however, a very much higher pressure is required, rising sometimes to as much as 12 lbs. above that of the atmosphere.

The apparatus, when employed for making ice, is provided with an ice-making tank, usually fitted with copper moulds ; or, when used for refrigerating purposes, it may be connected with a system of cooling pipes. The brine circulation is maintained by means of a suitable pump, and the brine, which is, as a rule, reduced to a temperature of about 10° Fahr. during its passage through the sets of tubes in the refrigerator c, is returned, after circulation, to the refrigerator to be re-cooled. The sets of tubes in the refrigerator are so arranged that the brine to be cooled circulates through them successively, being thus gradually reduced in temperature.

When employed for cooling water or other liquids, the liquid is usually passed at once through the refrigerator *c* in place of the brine.

In Charles Tellier's apparatus, which was designed some years later, the refrigerating agent employed is methylic ether, which liquid has a latent heat of vaporisation of 473, and which enters into ebullition at tension of the atmosphere at a temperature of from 20° to 25° below zero Fahr., whereas sulphuric ether, employed in the improved Harrison machine, as before mentioned, boils at 96° Fahr., a difference of about 121°.

Methylic ether is the result of the action of sulphuric acid upon ligneous alcohol, that is to say, alcohol distilled from wood. To obtain methylic ether, sulphuric acid is mixed with ligneous alcohol in equal proportion, and heated until the ether is evolved, carrying with it a number of bye-products, such as sulphurous acid, carbonic acid, and empyreumatic vapours, which must be eliminated by passing the impure vapour through or over liquids, &c., by which they will become absorbed and retained. For instance, by passing the adulterated vapour over potash, the carbonic and sulphurous acids will be retained by the alkali, the aqueous vapour being at the same time carried away mechanically.

In the distillation of methylic ether on a large scale, a great difficulty would be experienced, under ordinary conditions, in getting a liquid, having so low a boiling point as -25° Fahr., to flow through the requisite pipes. To overcome this difficulty, Tellier designed the special apparatus illustrated in sectional elevation in Fig. 10, wherein the vapour, after purification, is brought back to a liquid state by pressure, and is thus rendered manageable.

In the drawing, *A*, *B*, *C* are large cast or wrought iron drums or receivers; *D* is the purifier; *E* is a special pump which sucks off the purified vapour and delivers it through the worm *F* in a liquid state into a set of receivers *G*, which latter are capable of withstanding a very high pressure, and from whence it can be drawn off, and will flow through the rest of the apparatus as easily as water.

Tellier's apparatus for the production of cold is shown in elevation in Fig. 11, wherein *A* is the refrigerator; *B* is a receiver or vessel in which the methylic ether is evaporated; *C* is the pump for drawing off the vapour from the latter; and *D* is the condenser, which is fitted with a suitable worm or coil. The vaporised methylic ether is either employed to lower the temperature of a solution of brine, by passing it through a series of tubes situated in the refrigerator and plunged in

the latter ; or it is carried on and permitted to expand in a suitable system of pipes, and so act direct to reduce the temperature of air-

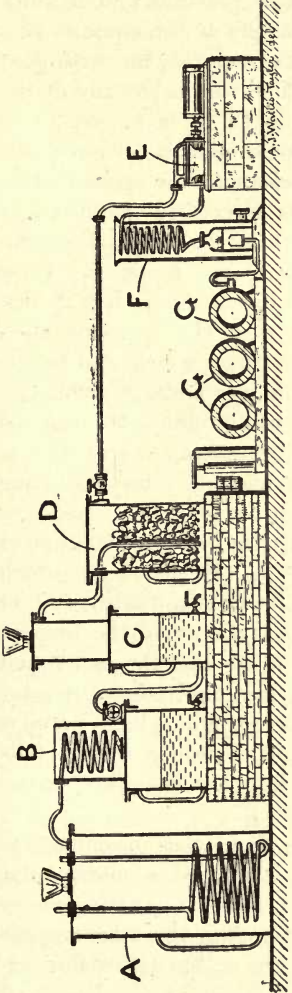

Fig. 10. — Tellier's Apparatus for the Distillation of Methylic Ether.

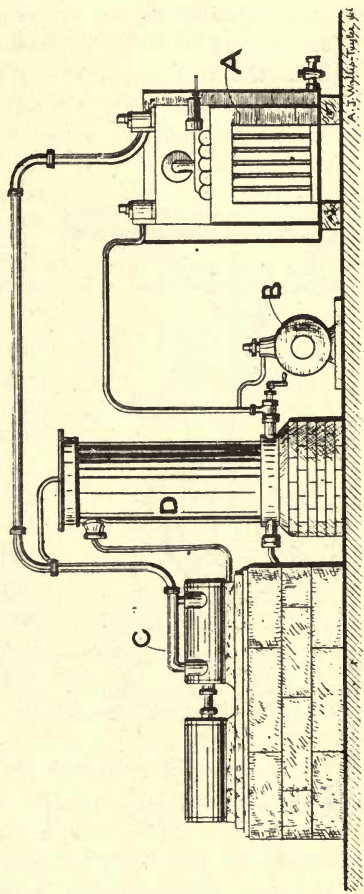

Fig. 11. — Tellier's Methylic Ether Compression Machine.

tight chambers. When in operation it is found that the pipes leading from the receiver B are so cold that they become coated with hoar frost ; whilst, on the contrary, when giving up the absorbed heat during

compression and liquefaction, the gas raises the tubes to a very high temperature, sometimes even approaching to a red heat.

The liquefaction of the methylic ether in the worm or coil of the condenser D gives rise to a certain amount of pressure, and to allow for this, and at the same time to permit a supply of the liquid to pass from the condenser to the evaporator B as required, an expansion valve or distributor, the construction of which will be readily understood from the enlarged sectional view, Fig. 12, is employed. E is the aperture through which the liquid methylic ether is delivered to a small chamber or recess F. G is the outlet aperture, the upper portion

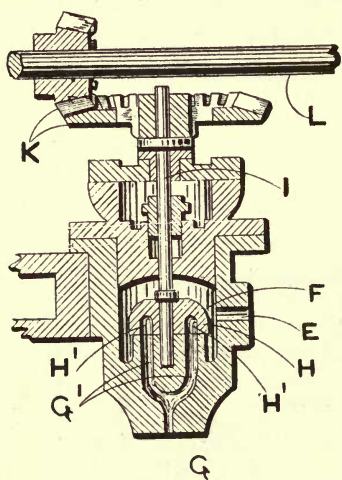

Fig. 12. — Expansion Valve or Distributor of Tellier's Methylic Ether Machine. Vertical Section.

of which is bifurcated as shown at G^1 , and which communicates with the refrigerator. H is a valve having two recesses H^1 , which correspond with the holes or apertures G^1 , and which valve is mounted on a spindle I, which is capable of being rotated through the bevel or mitre gearing K, and shaft L, and works upon a suitable seating in the bottom of the recess or chamber F. During the revolution of the valve H in the chamber F, which latter is always maintained full of liquefied methylic ether, the recesses H^1 become filled with the latter, and every time that the recesses register with the corresponding holes or ways G^1 , the liquid contained therein falls by gravity into the latter and passes

away to the refrigerator through the outlet G.

About the same time as the preceding, an ether machine was patented by Della Beffa and West, which comprised a multitubular refrigerator in which the ether was volatilised, a double-acting air or vacuum pump exhausting this vessel and pumping the ether vapour into a condenser; and likewise a special form of the latter for condensing the ether vapour.

The following particulars regarding an ether machine are given* by Mr Lightfoot as being the result of actual experiments made in this

* *Proceedings, Institution of Mechanical Engineers, 1886, p. 214.*

country, and serving to show what may be expected under ordinary conditions:—

| | | | |
|--|-----------------|-----------------|------------|
| Production of ice per twenty-four hours | - | - | 15 tons. |
| " " per hour | - | - | 1,400 lbs. |
| Heat abstracted in ice-making, per hour | - | 245,000 units.* | |
| Indicated horse-power in steam cylinder, excluding that required for circulating the cooling water and for working cranes, &c. | - | - | 83 I.H.P. |
| Indicated horse-power in ether pump | - | - | 46½ I.H.P. |
| Thermal equivalent of work in ether pump, per hour | 119,261 units.* | | |
| Ratio of work in pump to work in ice-making | - | - | 1 to 2.05. |
| Temperature of water entering condenser | - | - | 52° Fahr. |

Mr Frederick Colyer, C.E., M.I.C.E., states† that he obtained the following results with a first-class apparatus when testing the working of some of the leading ether machines, viz.: "In an ether machine made by Messrs Siebe Gorman & Co., capable of cooling 3,200 gals. of water from 60° down to 50°, or abstracting 320,000 heat units* per hour, the average experiments gave 4,250 gals. per hour cooled 10° Fahr. The temperature of the water at the inlet was 54°, and that of the water used for condensing purposes was the same. The maximum cooling effected was 449,437 heat units* abstracted per hour, being from 35 to 40 per cent. above the nominal power of the machine. The condensing water used per hour was 1,262 gals., or about three-tenths of a gallon for every gallon of water cooled. The coal consumed was 3¼ cwt. per hour; it was of indifferent quality, or the consumption would have been smaller. The steam cylinder was 21 in. diameter and 27 in. stroke; the air-pump 24 in. diameter and 27 in. stroke. The speed of the engine was fifty-eight revolutions per minute, with 48 lbs. of steam cut off at one-third of the stroke. The indicated power of the engine was 53 H.P., and of the air-pump, 29.2 H.P. The boiler was 7 ft. diameter and 24 ft. long, and gave an ample supply of steam."

This, he stated, was the most efficient ether machine that had come under his notice at that date, and contained several improvements not usually found in others of the same class.

According to the same authority the ether system is more expensive than the ammonia system (which latter will be considered in the next chapter), especially in London where coal is expensive, and water has frequently to be obtained from the water companies. The latter item is undoubtedly in this case one of considerable moment, as water is

* A thermal unit is that amount of heat required to raise the temperature of 1 lb. of water 1° by the Fahrenheit scale when at 39.4°. Mec. eq. 778 ft.-lbs.

† *Proceedings, Institution of Mechanical Engineers*, 1886, p. 248.

required in larger quantities for condensing purposes in the ether system, and consequently the high temperature which it sometimes attains in the street mains during the summer months becomes a matter of serious importance as regards the economical working of the machines.

Other objections to the use of ether as a refrigerating agent are, that, owing to its low vapour tension, a very large volume has to be circulated to perform a given refrigerating effect, thus abnormally increasing the dimensions of the apparatus; rapid deterioration under repeated vaporisation and re-condensation; and finally that it is extremely inflammable and explosive. On the other hand, however, it is possessed of the quality of working with a low pressure in the condenser, which renders its use advantageous in hot climates.

Modern types of ether machines will be found dealt with in another chapter.

Van der Weyde's (American) apparatus comprises exhaust and force pumps, a cooling coil and two refrigerators, the latter also acting as reservoirs for the condensed liquid. The most usual refrigerating agents employed are naphtha, gasoline, rhigoline, or chimogene.* The water to be frozen is placed in moulds or vessels plunged in other vessels containing glycerine, and which latter are surrounded on the outside by cyrogene. The naphtha, gasoline, rhigoline, or chimogene is evaporated by means of an air-pump and forced through the refrigerator, the evaporation of the cyrogene abstracting sufficient heat to form ice.

In Raoul Pictet's machine sulphur dioxide or sulphurous acid (SO_2) is employed as a refrigerating agent. Sulphur dioxide is prepared by burning sulphur in dry air or oxygen gas, or by removing the elements of water, and an additional atom of oxygen from sulphuric acid by heating it together with copper clippings or mercury. The purification of the resultant gas is effected by washing, and it is collected either by displacement, or over mercury. It is completely colourless, has the overpowering odour of burning sulphur, neither supports combustion nor respiration, is 2.247 times heavier than air, is easily condensed, is liquefiable by cooling down to 14° Fahr. under ordinary atmospheric pressure, and congeals into a transparent solid at temperatures below -168° Fahr. This gas deviates considerably from Boyle's law of pressures, and occupies less space for equal increments of pressure than does air under like conditions, this variation becoming more marked as the temperature is reduced. Sulphurous acid is extremely soluble in water, one volume of the

* Knight's "Practical Dictionary of Mechanics."

latter at a temperature of 50° Fahr. being capable of dissolving 51·38, and at 68°, 36·22 volumes of the former. It has a molecular weight of 65 and a density of 32. The latent heat of vaporisation of this liquid is 182, and it boils at a temperature of 14° Fahr. at the tension of the atmosphere.

In Pictet's apparatus the refrigerator and ice-tanks are combined, the circulation of the brine being effected by means of a fan, and the space occupied is thus considerably reduced, the efficiency being also somewhat augmented.

In 1885 Pictet applied for a British patent for an improved material for use in refrigerating apparatus wherein anhydrous sulphurous acid is employed, consisting of the admixture with the latter of carbonic anhydride. The sealing, however, was successfully opposed and consequently no patent was granted for this invention.

The employment of sulphurous acid is objectionable, by reason of its liability to become converted, by combining with the constituents of the atmosphere, into sulphuric acid and to corrode the machine. Modern machines using this agent are described in another chapter.

In a patented machine of Windhausen's the refrigerating agent employed is what is indifferently known as carbon dioxide (CO₂), carbonic anhydride, or carbonic acid, which material is gaseous at ordinary temperatures, and under ordinary pressures, but which liquefies at a pressure of 540 lbs. Carbonic acid gas does not burn, neither supporting combustion nor respiration.

Windhausen's apparatus is fitted with a pair of compressors placed in line with steam cylinders of the compound type, arranged side by side with a surface condenser between them. The gas condensers are situated in the base of the machine, and a separate refrigerator is provided in connection with each of them, constructed of coils of wrought-iron pipes mounted in a steel casing, wherein the brine is circulated. The duplicate portions of the machine are usually so arranged as to admit of either of them being worked separately, or both together, if desired. This is advantageous inasmuch as it renders the apparatus practically equal to two independent or separate machines, and affords the same immunity from a complete breakdown. The later patterns of this machine, which will be found described in another chapter, comprise several patented improvements by J. & E. Hall, Ltd., who are also the proprietors of the original Windhausen patent.

Fig. 13 is a vertical central section, some of the parts being left in elevation, showing the Windhausen compressor for treating the gas in two stages. Figs. 14 and 15 are enlarged views, showing more

clearly the details of construction of the inlet or suction valve, and of the outlet or discharge valve. As will be seen from the illustration the

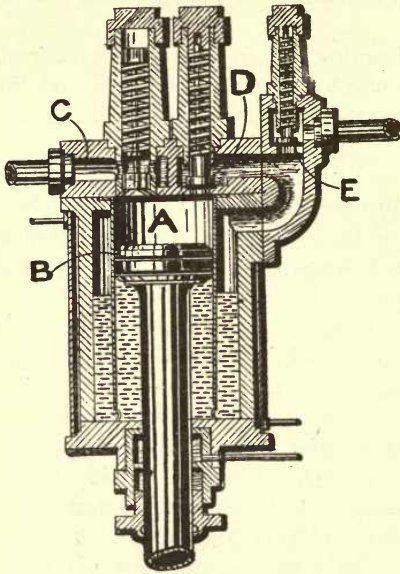

Fig. 13.—Original Type of Windhausen Compressor, with Liquid Piston, for treating the Gas in two Stages. Vertical Section.

inner cylinder A is surrounded by an annular space communicating with the former through the valve D; C is the inlet which communicates with the cylinder A through a suitable valve, and through which the gas to be compressed is drawn or sucked into the cylinder; B is the piston, and E is a valve through which the annular space or clearance round the cylinder A communicates with a pipe leading to the condenser.

In operation the gas is primarily drawn into the cylinder A, through the inlet valve C, where it is compressed, and discharged through the valve D to the above-mentioned annular space, wherein it is finally compressed by the oil shown in the latter and the cylinder A, which communicate at their lower ends through suitable holes or apertures, and which oil forms a liquid piston. After this second and final compression the gas is discharged through the valve E to the condenser.

Another machine adapted for the use of carbon dioxide as a refrigerating agent is found in that of Lowe. It comprises a gasometer or gas-holder, a pump, a condenser or cooler, a drier charged with chloride of calcium, a water-cooled condensing coil, and a refrigerator or ice-making tank. In operation the gas is admitted to the pump, liquefied under the action thereof, and the heat thus generated is absorbed or taken up in the cooler, after which it is allowed to expand into the refrigerator, where it acts in the usual manner, and is finally returned to the gas-holder.

A number of other refrigerating machines on the carbonic acid or carbonic anhydride system will be found described in another chapter.

Carbonic acid, carbon dioxide, or carbonic anhydride (CO_2) is completely inodorous; incombustible; and has the further advantage that, as it has no affinity for copper, it can be used with that metal with impunity. This is an important quality for marine installations, and consequently it has been used to a large extent for that purpose. On the other hand, however, its presence in quantity is fatal to animal existence—an objection, however, shared by most of the other agents used—and it has the further drawback that with the cooling water at a high temperature, it requires a considerable pressure to liquefy it,

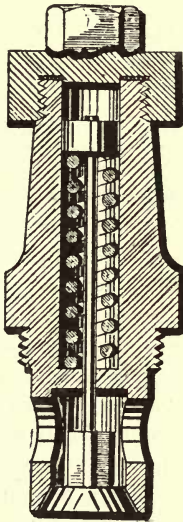

Fig. 14.—Suction Valve of Windhausen Compressor, for treating the Gas in two Stages.

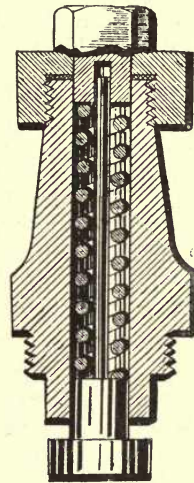

Fig. 15.—Outlet or Discharge Valve of Windhausen Compressor, for treating the Gas in two Stages.

viz., with condensing water at a temperature of 70° Fahr. it would require a pressure amounting to about 1,000 lbs. per square inch.

Carbonic acid or carbon dioxide must not be mistaken for the still more deadly gas known as carbon monoxide or carbonic oxide gas (CO), the inhalation of even a minute quantity of which will produce death. Sir Henry E. Roscoe, F.R.S., gives the vapour tension of carbon dioxide or carbonic acid, at $35\cdot5$ atmospheres at a temperature of 0° Cent. (32° Fahr.), and at $73\cdot5$ atmospheres at a temperature of 30° Cent. (86° Fahr.).

CHAPTER VI

THE COMPRESSION PROCESS (*continued*)

Ammonia Machines—Properties of Ammonia—Cycle of Operations—Wet and Dry Compression Principle—Construction of Gas Compressors—Various Examples of Modern Machines.

A REFRIGERATING agent now very largely employed, and considered by many the most efficient one known at present, is anhydrous ammonia (NH_3), which has a molecular weight of 17 and a density of 8.5. This liquid boils at 40° below zero Fahr. at atmospheric pressure; it has a latent heat of vaporisation of 900, and a vapour tension of 108 lbs. per square inch at a temperature of 60° Fahr. Gaseous ammonia can be liquefied at a pressure of 128 lbs. to the square inch at a temperature of 70° Fahr., and at a pressure of 150 lbs. at a temperature of 77° Fahr., the pressure required to produce liquefaction rising very rapidly with the temperature. To liquefy by cold it requires to be reduced to a very low temperature, viz., -85.5° Fahr. The latent heat of ammonia is very great, consequently its value as a refrigerating agent is proportionately large. Anhydrous ammonia is manufactured which contains only .025 per cent. of moisture.

The only alterations required in an ether machine to render it suitable for use with anhydrous ammonia as a refrigerating agent, are those made necessary by reason of the higher pressure of its vapour, and of the injurious action which it exercises upon copper, which causes the use of brass or gun-metal in any of the parts with which either the liquid or the vapour comes in contact to be undesirable.

This latter quality is a serious drawback to its use for marine work, as is also its inflammable and irritant nature in case of an escape.

The chief advantages derived from the use of anhydrous ammonia as a refrigerating agent are that it possesses greater heat-absorbing power than any of the others named, excepting water; that it liquefies at a comparatively low pressure; and that it is not as explosive or as inflammable as ether.

Ammonia is, however, very far from being innocuous and safe, and due precautions should be taken to avoid accidents where it is in use. It is a colourless irrespirable gas, having an extremely pungent, peculiar, and easily recognisable odour, and it is also slightly combustible when mixed with a sufficient proportion of air, burning feebly with a flame of a greenish-yellow hue, and when mixed with about twice its volume of air, being capable of exploding with considerable violence. From this it will be clear that it is absolutely essential that no part of an ammonia apparatus should have a naked light inserted into it, until it has been open and exposed to the air for a sufficient time to render the presence of such light harmless. The tendency of ammonia gas, owing to its being only half the weight of air, is to rise when set free, so that there is the less likelihood of any person who might chance to be near when an ammonia pipe happens to burst, or a bad leak to take place, becoming overpowered by the gas.

Another objectionable feature of ammonia, which has been already alluded to, is its very strong action on copper and its alloys, by reason of which no such material can be employed for any part of an ammonia machine.

Common ammonia of commerce is a solution of ammonia gas in water, and its usual strength is 26° Beaumé. Anhydrous ammonia is pure dry ammonia gas compressed to a liquid, and it is manufactured by the distillation of the ordinary 26° ammonia of commerce in a suitable apparatus. This apparatus, which should be of sufficient strength to stand a pressure of 65 lbs. on the square inch, comprises a still, a condenser, three separators, and a drier or dehydrator. The still is heated, by a suitable steam coil, to a temperature of about 212° Fahr., when the ammoniacal gas, together with a certain amount of water, passes off into the first separator, which latter is usually situated on the top of, and forms an upward extension of, the still. In this first separator the greater portion of the watery particles carried over are eliminated by a series of perforated plates, through which perforations the gas has to pass, and are returned to the still through a dip pipe. From this first separator the partially dried gas passes through a water-cooled worm in the condenser, and then successively through the two other separators to the drier or the dehydrator, where it is passed through a set of similarly perforated plates to those in the first separator, but having small sized lumps of freshly burnt lime placed upon them, by which any moisture that may still remain in the gas is removed, and the completely anhydrous product can then be passed into the ammonia pump or compressor.

It is found advisable to work the still at a pressure of about 30 lbs. to the square inch, so as to admit of its being raised to a slightly higher temperature than the boiling point of water at atmospheric pressure, without causing the water to boil, the result of this being that the whole, or practically the whole, of the ammonia will be set free, whilst at the same time the least possible amount of the water will be vaporised and pass over with the ammonia gas.

To ascertain whether or not all the ammonia has been eliminated, two methods of testing the charge in the still are usually practised. The first is to draw off a small quantity of the charge, and if this fails to turn litmus paper, then the charge is exhausted, and all the ammonia has been driven off. The second is to allow a small amount of the gas leaving the still to escape through a small cock or valve specially provided for the purpose, when if this gas be tested with turmeric paper, and if this latter remains unchanged in colour (yellow), the charge is completely spent; if, however, the paper on the contrary turns of a brown hue, there is still some ammonia left.

After the distillation is finished the water remaining in the still should be run out, and as soon as the temperature of the latter is sufficiently lowered it can be again charged. The water accumulating in the second and third separators, being saturated with ammonia gas, may be returned into the still when recharging the latter. The amount of ammonia water, however, that becomes deposited in the separators will be very small if the pressure in the still is maintained at about 30 lbs., as above-mentioned.

The lime in the drier or dehydrator must be removed whenever it is found to have become in any degree slacked.

Commercial ammonia of 26° Beaumé contains 38.5 per cent. of anhydrous ammonia by volume, it is therefore easy to calculate from this the quantity that it would be necessary to distil in order to produce any given amount of anhydrous ammonia.

Ammonia gas or vapour is, owing to its searching nature, very troublesome to deal with, even at a low pressure, consequently this difficulty is greatly increased by the comparatively high pressure or tenuity that is obtained in a compression machine, and which rises in the condenser to as much as 180 lbs. per square inch. Liability to leakage of the ammonia gas at the pump glands and other parts of the apparatus forms, therefore, one of the objections to the use of ammonia as a refrigerating agent, and the means employed to prevent this leakage one of the chief points of difference between ammonia and ether machines. Another difficulty to overcome is the liability to an imper-

fect discharge of the gas from the compressor-pump, and the expansion and consequent back pressure of that remaining therein.

The most important part of an ammonia machine working on the compression principle, and indeed of all apparatus wherein a volatile liquid is compressed, is the gas compressor. In ammonia machines both single and double acting compressors are employed. A single-acting compressor has the advantage when working with a gas of the tenuity of ammonia, owing to its only carrying the lesser pressure of the suction side over the stuffing box, of preventing the stuffing box from being subjected to the high pressure of the condenser, which is unavoidably done at the termination of each stroke in a double-acting compressor, and on this account the chance of leakage is, of course, greatly reduced. On the other hand, however, it is obvious that a double-acting compressor must be more advantageous from an economical point of view, inasmuch as it deals with nearly twice the amount of gas at each revolution of the crankshaft that a single-acting compressor of the same diameter and stroke is capable of operating upon. Moreover, the same amount of friction is engendered in each case (although with a double-acting compressor double the duty is being performed), at least, so far as regards the friction of such moving parts as the crosshead, piston, and connecting-rod—which friction causes no inconsiderable loss, for to overcome friction power has to be expended, and waste of power means loss of fuel, *i.e.*, money. But in a double-acting compressor a considerable amount of extra friction is caused by the necessity of working with a tighter gland. Taking everything into consideration, however, it is estimated that the amount of saving effected in a machine having two gas compressors may be placed at one-eighth of the whole amount of power required for compressing the gas. A further economy is that a double-acting compressor is capable of performing the work of a pair of single-acting ones of the same size, and consequently there is a saving in the first cost of the apparatus and in space occupied.

The construction of a gas compressor for operating with ammonia does not, as already mentioned, vary in any very material point from that of one intended to work with ether, and, however much they may differ from one another in minor points of detail, they all work upon the following broad principles, *viz.* :—

The gas compressor, which is operated by a steam engine or other suitable motor, draws the gas or vapour from the evaporating coils or tubes of the refrigerator after it has performed its duty of cooling, compresses it on the return stroke of the piston, and forces it into a system

or series of pipes or coils in the condenser, in which coils, under the cooling action of water, it resumes its liquid form. From the condenser it is again passed in the liquid state, through a minute opening of the expansion or regulating cock, into the evaporating coils or tubes of the refrigerator, wherein it again expands into gas or vapour, owing to the diminished pressure there prevailing, by reason of the sucking action of the gas compressor. The pressure in the pipes or coils in the refrigerator is usually maintained at from 15 lbs. to 30 lbs., whilst that in the condenser, as above mentioned, may rise as high as 180 lbs., the former depending of course on the amount of opening given to the expansion cock. The liquid ammonia passing suddenly from the above high pressure of the condenser to the comparatively low pressure in the refrigerator, instantly flashes into gaseous form, and whilst doing so, in conformity with the well-known natural law, is forced to absorb a quantity of heat which it renders latent; this it does from the surrounding objects, which in the present instance are either the pipes or coil in the refrigerator, and the brine circulating round the latter, or when used for cooling on the direct system, the sets of refrigerating pipes into which it is passed and the surrounding air.

In order to avoid any chance of accidents occurring through the machine being started with all the valves closed, a suitable relief or safety valve and by-pass should invariably be provided.

Expressed generally, then, the cycle of operations in machines on the ammonia compression system is the same as that of those described in the preceding chapter, viz., compression, condensation, and expansion; and these machines, no matter how they may differ in more or less important points of constructional detail, must all likewise consist of three different parts, viz., a compression side, a condensing side, and an expansion side (see Fig. 8). The operations are rendered continuous by suitably connecting all these sides or parts together so that the gas passes through them in the above order.

Ammonia compression machines are operated on two systems, viz., wet compression and dry compression, and as regards the respective merits of these systems theoretically, considerable diversity of opinion seems to exist. In practical work, however, it will be found that what are termed dry compression machines—for reasons given below—are worked more or less wet, and, therefore, the efficiency as regards this point is about the same in the case of both types of machines.

When intended to work on the wet compression system the expansion cock or valve is adjusted in such a manner that the vapour will come back to the compressor in a supersaturated condition, with the

result that this surcharge of liquid becomes evaporated during the compression stage, absorbing the required quantity of heat, and maintaining a correspondingly low temperature in the compressor cylinder. An obvious objection to this method of working is the constant liability of too large a quantity of liquid finding its way into the compressor cylinder, the result of which would be the filling of clearance spaces with liquid ammonia, which latter would re-expand upon the return stroke of the piston, and take up space which is required for the reception of the inflowing gas or vapour.

With a machine adapted to work on the dry compression system, the expansion cock or valve is so adjusted that the whole of the liquid ammonia admitted to the expansion coil will become expanded into gas or vapour, and the latter consequently reaches the compressor cylinder in a dry condition, superheating taking place during compression. It will be observed that this plan admits of the full value of the liquid ammonia being utilised for purposes of refrigeration, a drawback being experienced, however, by reason of the higher pressure which becomes necessary to liquefy the ammonia, and the larger amount of heat generated which calls for special cooling arrangements for its removal. For this reason in this system compressors are, as before mentioned, usually worked partly wet.

The principal qualities to be sought for in a compressor in order to ensure the maximum amount of efficiency are:—As complete a discharge from the compressor cylinder of the gas during compression as is practically feasible, and the removal during compression of the greatest possible amount of heat from the gas. Amongst other points of importance are the perfection of the means provided for preventing any leakages taking place at the stuffing box, pistons, and valves, and of those for ensuring the proper lubrication of the working parts of the machine.

Of these desiderata the first is the most important, and it is thus specially desirable to see that the compressor possesses all the requisite conditions to ensure its fulfilling its purpose in the best possible manner. One method of effecting the desired object is by the injection of a certain amount of sealing oil into the cylinder at each stroke of the piston, which oil forms what is called a liquid base. The injection of this oil serves not only the purpose of sealing the piston, but also lubricates the latter and the valves, and prevents leakage at the stuffing box, and that, moreover, owing to the small amount of such sealing oil that is employed, without appreciably reducing the capacity of the machine.

The practically complete discharge of the charge of ammonia from the compressor cylinder, at each stroke of the piston, can also be ensured by allowing the latter to work right up to the heads without clearance. In the ordinary form of compressor this would of course give rise to a great liability of knocking out the cylinder head in the event of any foreign body or obstruction obtaining access to the cylinder, but such action is rendered possible with perfect safety by so arranging the head that it is loose, but normally retained in position

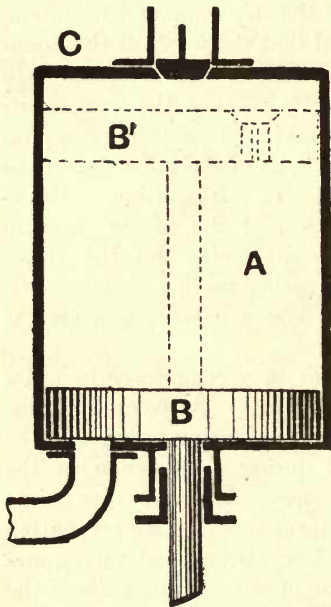

Fig. 16.—Diagram illustrating Loss due to Clearance Space in Compressor Cylinder.

by means of suitable springs. In this manner the head forms practically a large relief valve adapted to open should the pressure in the compressor cylinder from any cause exceed that requisite to produce liquefaction of the ammonia gas.

The diagram, Fig. 16, which is intended to represent the cylinder of a single-acting compressor, illustrates the loss due to clearance space. As is well known, according to Boyle's or Marriot's law the volume of gas will vary in an inverse proportion to the pressure. Assuming, then, that the pressure of the gas on entering the cylinder A be 20 lbs. per square inch, and that of the condenser 180 lbs. per square inch, it will be seen that if the piston B is moved into the position shown in dotted lines at B¹ through a stroke of 9 in., and neglecting loss of heat during compression, the pressure of the gas will be increased nine times, whilst its volume

will have become, at the same time, correspondingly reduced to one-ninth of its original volume, and this pressure of 180 lbs. per square inch is that at which it is required that the gas should leave the cylinder A.

If the clearance space left between the piston B at the termination of its stroke and the cylinder head C be 1 in., it is obvious that the gas at a pressure of 180 lbs. per square inch left in this clearance space will re-expand until the pressure becomes reduced or decreased

to a ninth of what it was originally, or to 20 lbs. per square inch, whilst the volume will, at the same time, be increased to nine times what it was before. It will be seen that in such a case as the above the inch of gas at 180 lbs. pressure would re-expand into 9 in. of gas at 20 lbs. pressure, and that consequently the entire efficiency of the compressor would be lost, as this back pressure in the cylinder of 20 lbs. per square inch is that of the entering gas, and would thus render impossible the entrance of any more gas. Were the stroke of the piston B, on the other hand, to be the full length of the cylinder A, so that no clearance be left at its termination between it and the cylinder head, it will be seen that all the gas would be expelled from the cylinder when it reaches that point, and consequently its efficiency, so far as this is concerned, would be practically perfect. In practice, however, it is found impossible to construct ordinary compressors without a certain amount of clearance at the termination of their strokes; it becomes necessary, therefore, to find out what is the minimum amount that can be allowed compatible with safety of working, and also how best to arrange the clearance so that the loss due to it will represent as small a percentage of the entire work of the compressor as practicable.

Obviously, whatever the space in the cylinder that will be occupied by the gas left in the clearance space after it has re-expanded to a pressure of 20 lbs. per square inch on the return stroke of the piston, the space thus occupied will represent the loss of efficiency. Say, for example, that we have a cylinder of 10 in. in diameter, by 10 in. stroke, and that a clearance of one-eighth of an inch be left at the termination of the stroke, with this clearance filled with gas at a pressure of 180 lbs. per square inch, the space filled by this gas on the return stroke of the piston, when the gas remaining over has expanded down to a pressure of 20 lbs. per square inch, will be $1\frac{1}{8}$ in., and the loss of efficiency will consequently be equal to about 11 per cent. If, however, we now assume that the diameter of the cylinder be still retained at 10 in., whilst the length of stroke be doubled, or increased to 20 in., the loss of efficiency will obviously be reduced to $5\frac{1}{2}$ per cent., whilst by again in like manner increasing it to 40 in., and subsequently to 60 in., it will be reduced to $2\frac{3}{4}$ per cent., and $1\frac{3}{8}$ per cent. respectively, and so on, the greater the ratio between the diameter and the stroke the less will be the loss of efficiency due to the clearance left in the cylinder at the end of the stroke of the piston.

In actual practice, however, there is a limit to the amount of the ratio between the diameter and the stroke that can be used with due

regard to economy of working. The practice in this respect amongst builders of refrigerating machinery varies considerably, some employing a ratio of two to one, whilst some others use less, and others again more. Mr Peter Neff, from whose articles upon "Mechanical Refrigeration" (*New York Engineer*), much of this information has been derived, recommends, as the result of his experience, a stroke of three times the diameter as being that giving the most favourable results.

Another important point is to see that no unnecessary amount of clearance space be left at the inlet and discharge valves. In the case of a single-acting compressor of the vertical type, this is a comparatively easy matter, as the inlet valve can be arranged flush with the top of the piston, and the outlet or discharge valve flush with the head of the cylinder, thereby reducing as far as possible loss from the re-expansion of any gas remaining between the seats of the valves and the interior of the cylinder. This difficulty is not, however, by any means so easily overcome in a double-acting compressor of the horizontal type, although many more or less ingenious arrangements have been devised for the purpose, one of the most efficacious of which is perhaps that wherein cages containing the valves are so mounted in the cylinder that the seats of the valves will be brought into close proximity with the interior of the latter.

Even in the case of the best possible designs of compressors of the ordinary type, there must be an unavoidable appreciable loss of efficiency from back pressure, but, on the other hand, they are of very much simpler construction, and can be built considerably cheaper than those provided with special means for avoiding, or rather minimising, this loss, whilst at the same time they are found to be perfectly well able to perform the work required of them. It must also be borne in mind that upon the engineer in charge of the plant, and the care which he expends to see that the valves are working satisfactorily, &c. &c., depends to a considerable extent the greater or lesser efficiency of the compressor under his charge.

In the De La Vergne type of ammonia compressor, which is made in this country by L. Sterne & Co., Ltd., the characteristic feature consists in the patented system for preventing the occurrence of any leakage of gas taking place past the stuffing box, piston, and valves, and of extracting the heat from the gas during compression, by the simple device of injecting into the compressor, at each stroke, a certain quantity of oil or other suitable lubricating fluid. By means of this sealing, lubricating, and cooling oil, not only are the stuffing box, piston, and valves effectually sealed, and the heat developed during

compression taken up, but all clearances are entirely filled up. This latter is a matter of great importance, as it ensures a complete discharge of the gas from the pump cylinder, and obviates the above-mentioned loss of power and efficiency.

This method of sealing the stuffing box and piston enables the leakage and consequent introduction of air into the pump, or drawing out or wasting of a volume of the refrigerating gas at each alternate stroke of the piston, to be effectually prevented without necessitating the packing of the piston and gland so tightly as to bind and set up an excessive amount of friction, the power required to overcome which has been sometimes found to exceed that necessary to perform the entire work of compression. Moreover, when working constantly against a pressure of from 125 to 180 lbs., it is obvious that the slightest wear would cause a considerable leakage of gas to take place past the piston into the adjoining chamber, and like difficulties would also be encountered with the valves, allowing the gas to regain access to the pump cylinder by leaking past the discharge valves, or to be readmitted to the suction side past the corresponding valves. The losses occasioned in this manner through abnormal friction, and the reduction in efficiency and loss of valuable material through leakages, constitute in some machines a very large item, and are the chief cause of failure to give satisfactory results.

It is claimed by the inventor that the oil injected into the compressor cylinder for the above-mentioned sealing purposes not only effectually overcomes the above difficulties, but also acts in a more efficient manner to absorb or take up the heat generated during compression by the mechanical energy exerted by the compressor piston or plunger upon the gas than does a water jacket to the cylinder and hollow water-cooled piston and rod, the useful effect of which latter is to a great extent prevented by the thickness of metal required in a pump destined to work at a high pressure. In order to ensure the highest efficiency in a compressor, it is essential that the heat generated by the act of compressing be eliminated as far as practicable, as otherwise this heat, by expanding the gas itself during compression, increases its volume, and consequently necessitates an opening of the discharge valve prior to the time that would be required were the gas cooled during compression. It is obvious that all the energy expended in effecting such premature discharge of the increased volume of gas is so much loss.

The oil used is of a special quality, which is unaffected by the chemical action of the ammonia, it being absolutely essential that it

be of a nature that will not saponify, and that it be also capable of withstanding both extremes of heat and cold.

Fig. 17 is a vertical central section, showing a double-acting compressor on the De La Vergne system, fitted with Louis Block's patent arrangement of valves, the main object of which is to secure the discharge of the oil at the lower end of the cylinder taking place immediately after all the gas is gone and not before, as in the latter case re-expansion will take place, resulting in loss of efficiency of the pump. To effect this, two valves are provided in the lower end of the compressor cylinder, one above the other.

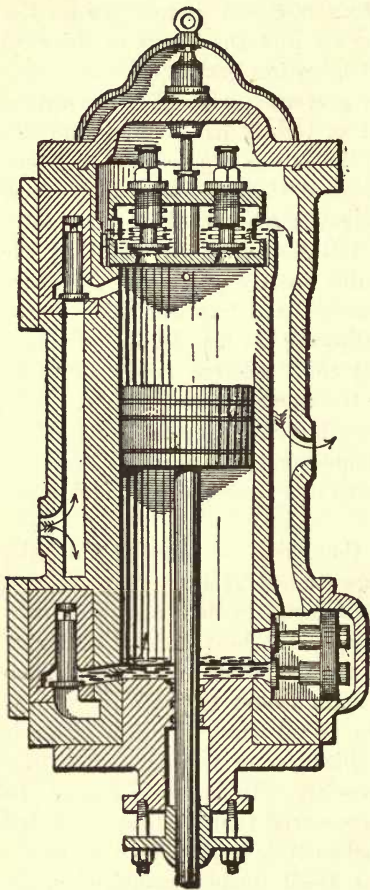

Fig. 17. — Double-Acting Vertical Type, De La Vergne Ammonia Compressor. Vertical Section through Compressor Cylinder.

Either or both of these valves may open on the down stroke of the piston, until the latter covers the upper one, when only the lower one is left open to the condenser. During the remainder of the stroke of the piston, after the lower valve is also closed, the other or upper one opens communication with an annular chamber formed in the piston. In the bottom of this annular chamber are provided, moreover, valves which open as soon as all the other outlets from the underside of the piston are closed, to ensure which they are loaded with springs, so arranged as to require somewhat more pressure to open them than the discharge valves on the side of the cylinder. The gas, and after-

wards the oil, then all pass out through the piston, no trace of the former being present at the completion of the down stroke. In this manner the oil system of sealing can be advantageously retained, and

the pump will work as well at the lower side as the upper. Fig. 18 is a view illustrating the complete machine, which is driven as shown by a horizontal tandem condensing engine.

A complete installation of a refrigerating plant on the De La Vergne ammonia compression system is shown in side elevation in Fig. 19, from which view the circulation of the ammonia and sealing oil can be easily traced, viz. :—

Firstly. Following the path taken by the ammonia, in order to produce the frigorific effect. A is the compressor cylinder, which is

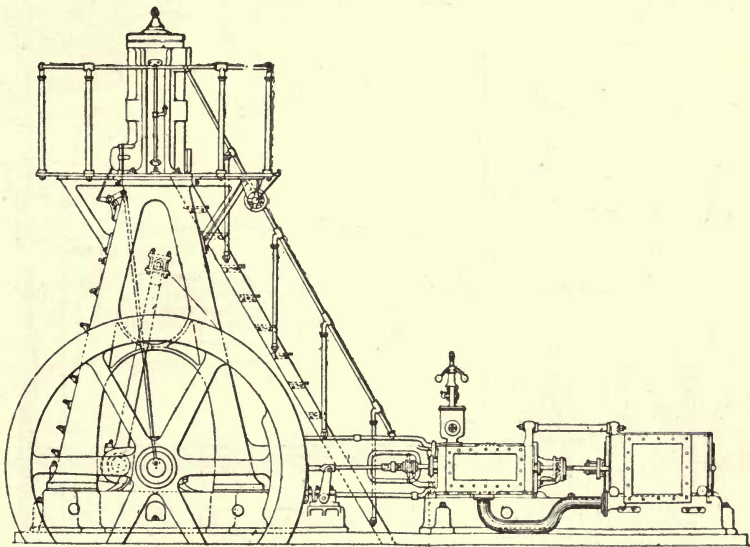

Fig. 18.—Double-Acting Vertical Type De La Vergne Ammonia Compressor and Horizontal Tandem Condensing Engine. Side Elevation of Complete Machine.

of the double-acting type, and similar in construction to that shown drawn to a larger scale in Fig. 17 ; and R is the steam-engine cylinder, which is arranged horizontally, as shown in Fig. 18. B is a pipe through which the gas is drawn or sucked from the evaporating coils into the compressing cylinder A. The gas is then discharged by the action of the compressor A through the pipe C into the pressure tank D, where the sealing oil or liquid, the course of which will be next followed, falls to the bottom ; the upper half or portion of the pressure tank being fitted with suitable cast-iron baffle or check plates serving to more completely retain the oil and ensures its

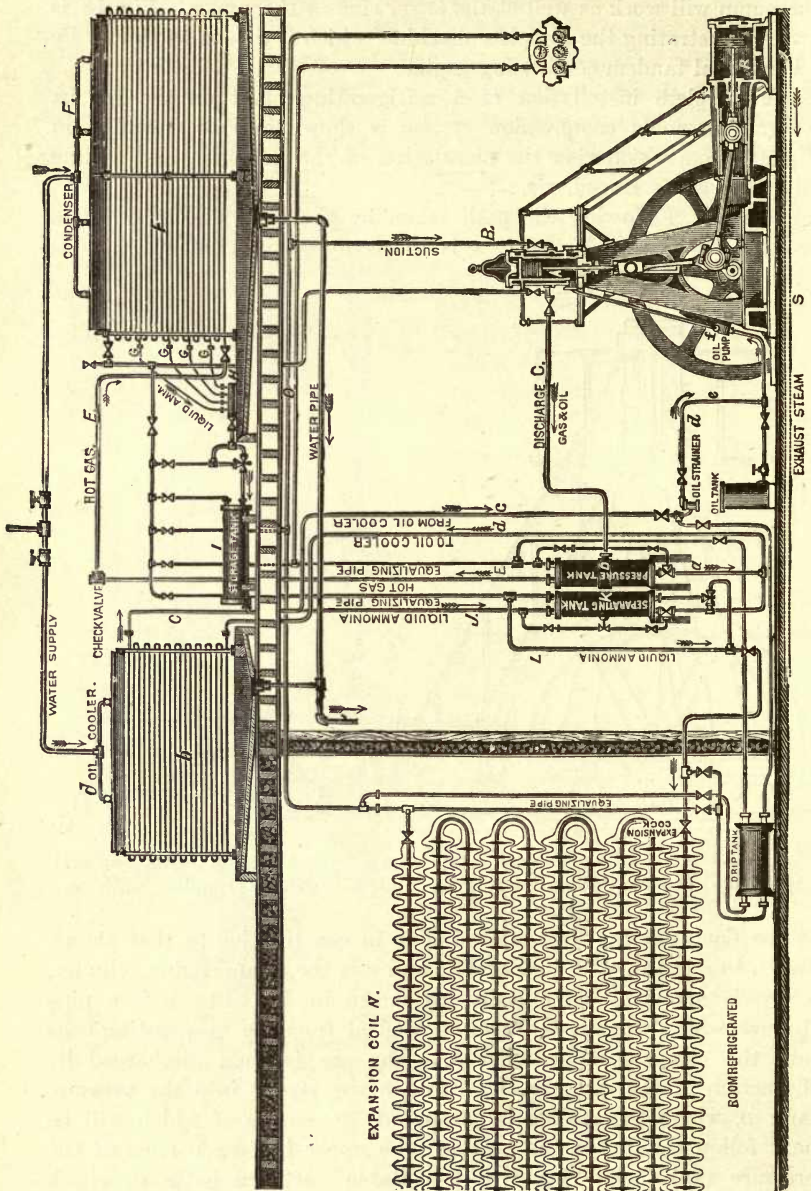

Fig. 19.—Diagrammatical View showing complete Installation of a Refrigerating Plant on the De La Vergne Ammonia Compression System.

deposition. From the pressure tank *D*, the gas, which still retains the heat due to compression, passes through the pipe *E* into the bottom or lower pipe of the condenser *F*, wherein, by the cooling action of cold water running over the pipes, the heated gas is first cooled and then liquefied. The ammonia, in this liquid condition, is then led by the small liquid pipes *G*, through the liquid header *H*, into the storage tank *I*, from whence it flows through the pipe *J* into the lower part of the separating tank *K*, which latter must be constantly maintained at the very least three-quarters full. *L* is a pipe of small bore, through which the liquid ammonia is forced, by reason of the pressure to which it is now subjected, to the expansion cock or valve, through which it is injected into the evaporating or expansion coil *N* which is situated in the room or chamber to be refrigerated or cooled.

The ammonia gas resulting from the expansion and evaporation of the liquid ammonia in the evaporating or expansion coil *N*, having absorbed or taken up the heat from the surrounding atmosphere, passes away through the pipes *O* and *B*, back again into the compressor cylinder, and the cycle of operations of compressing, &c., are again performed as above.

Secondly. Following the course of the oil employed for sealing, lubricating, and cooling purposes, which, as previously mentioned, is heated with the gas during compression, and is passed into the tank *D*, to the bottom of which it falls. From the bottom of the tank *D*, the heated oil is conducted through a pipe *a* to the lowermost pipe of the oil-cooler *b*, which is practically similar in construction, but on a smaller scale, to the ammonia condenser, and is likewise cooled by sprayed or atomised cold water. After being sufficiently reduced in temperature in the oil-cooler *b*, the oil flows through the pipe *c*, strainer *d*, and pipe *e*, into the oil-pump *f*, which latter is so constructed that it delivers the cooled oil into the compressor, distributing it to either side of the piston or plunger during its compression stroke, that is to say, in such a manner that no oil is furnished during the suction stroke of the piston, but only during the time of compressing, thereby cooling the gas during its period of heating. The heated oil, after leaving the compressor, then again returns, together with the hot compressed gas, to the pressure tank *D*, and follows the same round through the oil-cooler *b*, strainer *d*, and oil-pump *f*, back to the compression cylinder. It will be obvious that the oil, as well as the ammonia, is used over and over again, no loss or waste of either taking place except that which may occur through leakage.

Any small quantities of oil, however, that may be carried over

with the current of the gas from the pressure tank *D* into the condenser *F*, pass along with the liquid ammonia into the separating tank *K*, where, by reason of its greater weight, this oil falls to, and collects at, the bottom of the tank. As soon as a sufficient quantity of oil has become thus deposited, it is drawn off and passed through the oil-cooler back into the oil-pump. The oil reservoir or tank is also connected to the oil-pump *F*.

When the apparatus is employed for the manufacture of ice, the evaporating coils *N* are placed in a tank containing brine, sufficient space or clearance being left between them to admit of the insertion of ice cans or moulds containing the water to be frozen. In this instance the steam used for driving the motor, after doing its duty

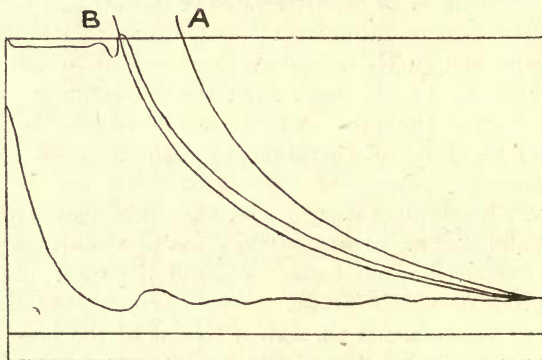

Fig. 20.—Diagram taken from Single-Acting De La Vergne Ammonia Compressor, without Sealing, Lubricating, and Cooling Fluid.

in the steam-engine cylinder *R*, is led through the exhaust pipe *S* into a steam filter and condenser, where it is purified and condensed. The purified condensation water then passes from the condenser into a water regulator tank, and from the latter through a water-cooled coil of substantially similar construction to that of the ammonia condenser *F* and oil-cooler *b*, and finally is delivered into the ice cans or cases, which are usually constructed of galvanised iron, through suitable india-rubber hoses, fitted with stop-cocks or valves.

When the water in the ice cans or cases is frozen, they are lifted out and transported by means of the overhead travelling crane to the dip-tank or a sprinkler, where the blocks of ice are thawed or melted out, after which the empty cans are refilled with water through the hose, and the process of making other blocks of ice is commenced.

The various parts are clearly indicated upon Fig. 19, and the paths taken by the ammonia, the sealing, lubricating, and cooling oil, and the steam are shown by the arrows.

The advantages derived from the use of the sealing, cooling, and lubricating liquid in the compressor cylinder will become very apparent on a comparison of the diagram shown in Fig. 20, which was taken from a gas compressor worked without employing the liquid, with that shown in Fig. 21, which was taken from a similar compressor, but with the charge of liquid.

The diagram shown in Fig. 20 was taken from a 14-in. \times 28-in. single-acting gas compressor, working with a direct pressure of 157 lbs., and a back pressure of 20 lbs., and at a speed of thirty-six revolutions

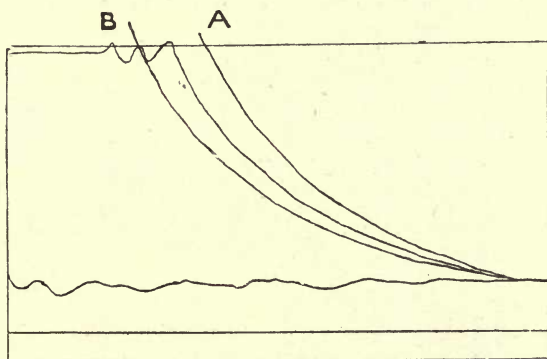

Fig. 21.—Diagram taken from Single-Acting De La Vergne Ammonia Compressor, with Sealing, Lubricating, and Cooling Fluid.

per minute, no sealing, cooling, and lubricating liquid being used. A indicates the adiabatic curve, and B the isothermal curve.

The adiabatic curve is, as is well known, that curve which would be produced were the air or gas to be instantaneously compressed, that is to say, without transmission of heat, and the isothermal curve is that which would result if it were possible to compress the same without raising its temperature at all. In actual working the curves obtained fall between the adiabatic curve and the isothermal curve.

It will be seen by an inspection of this diagram that the compression curve, which by right should approach the adiabatic curve A, on the contrary falls into close proximity to the isothermal curve B, and indicates the existence of a leakage past the piston of 15.2 per cent. of the gas being compressed, and, as is shown by the curved line, which

is produced by the re-expansion of the gas filling the clearance between the piston and compressor head or cover, a further loss from the latter source of 7.4 per cent., that is a total loss of 22.6 per cent., due to not employing the liquid. The horse-power shown on this indicator card is 44.

The diagram shown in Fig. 21 was taken from a similar compressor running at the same speed, and working at 150 lbs. direct pressure, and with a back pressure of 27 lbs. The actual power indicated by this card is 48. The horse-power measured to the adiabatic curve A equals 53.6. The horse-power saved by employing the sealing, lubricating, and cooling liquid is 5.6 for each compressor, or in a machine having two compressors a total saving of 11.2 H.P. The efficiency of the compressor is 98.6 per cent. of its theoretical value, a result attained

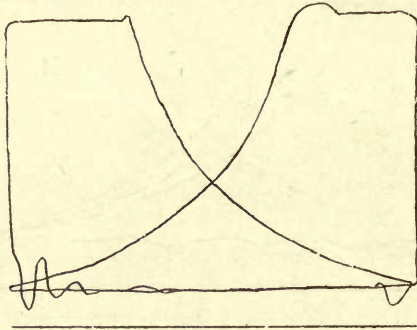

Fig. 22. — Diagram taken from Double-Acting De La Vergne Ammonia Compressor, with Sealing, Lubricating, and Cooling Fluid.

by the use of the liquid. The efficiency of the compressor, as indicated by the card shown in Fig. 20, is only 77 per cent. of that indicated by the card shown in Fig. 21, the loss being the result of the non-use of the sealing liquid.

Fig. 22 shows a diagram taken from a 12-in. \times 24-in. double-acting gas compressor, running at a speed of thirty-four revolutions per minute, and fitted with Louis Block's patent improvements, which latter have been already described on pages 58 and 59.

The steam cylinder actuating the above-mentioned 14-in. \times 28-in. gas compressor, whilst the diagrams shown in Figs. 20 and 21 were being taken, was 18 in. \times 42 in., and was working under a steam pressure of 68 lbs. per square inch, the speed being, of course, the same as that of the gas compressors, viz., thirty-six revolutions per minute.

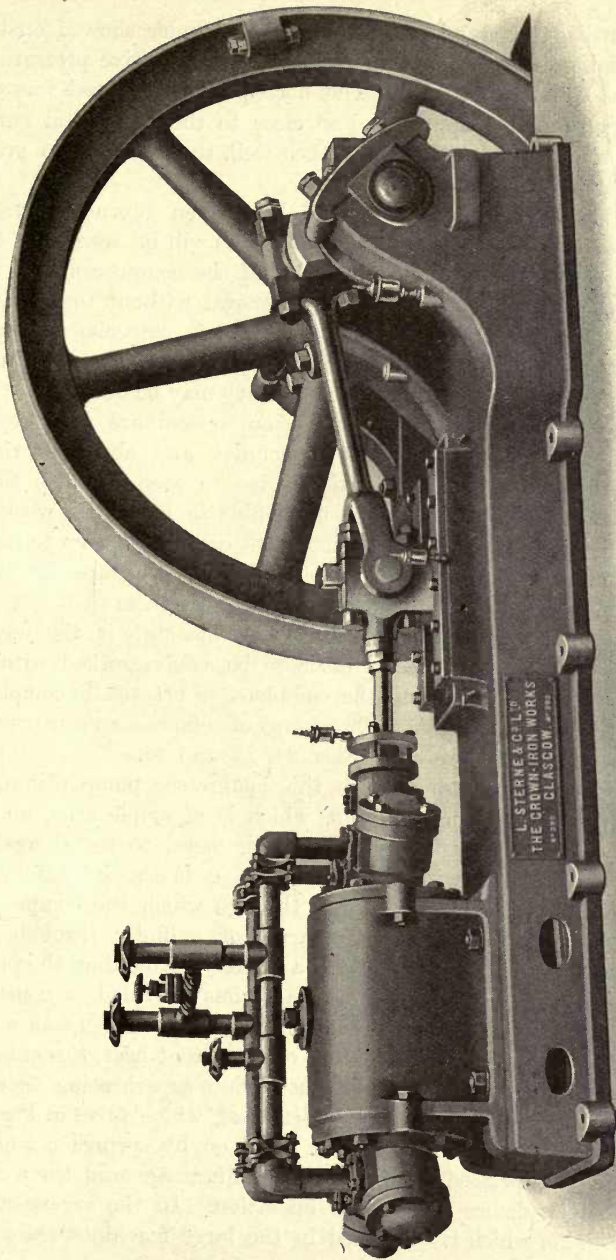

Fig. 23.—Horizontal Type of Belt-driven Sterne Ammonia Compressor.

Indicator diagrams taken from this steam cylinder showed on the card an initial pressure of 65 lbs., and the mean effective pressure of the diagrams equalled 32.4 lbs. The horse-power developed was 63, and the expansion line approached so close to the theoretical curve as to show that the cut-off valve worked well, thus effecting a great economy in steam consumption.

Fig. 23 shows a horizontal type of belt driven Sterne ammonia compressor of the latest design. The valves, as will be seen from the illustration, are arranged in the end covers of the compressor, and are placed in cages so as to admit of their removal without there being any necessity for disturbing the compressor joints. Special attention has also been paid to the reduction of the clearance spaces to a minimum so that the greatest possible efficiency may be obtained.

Machines on the ammonia compression system are made by a number of other firms, both in this country and abroad, certain specific improvements being claimed to give to each of them some particular advantage. It would be impossible in this little work to give extended descriptions of these machines, or, indeed, even to make brief mention of all of them. The following, however, are the most salient features of some of the principal amongst them:—

The characteristic feature in the Frick machine is the means adopted for permitting the compressor to be safely worked without clearance, and thereby ensuring the complete, or practically complete, discharge of the gas therefrom. Two forms of compressors constructed on this principle are illustrated in Figs. 24, 25, and 26.

Referring to the drawings, A is the compressor pump piston, in which is placed the suction valve B, which is of ample area, and is balanced by a spring; the piston working metal to metal against the top cylinder head without clearance. C is the inlet for the ammonia gas, and D is the outlet way through which the compressed gas is discharged from the pump barrel or cylinder through the aperture and valve in the dome. F is a jacket surrounding the pump cylinder, and into the clearance or space thus provided, a constant stream of cold water is kept circulating, so as to take up as much of the specific heat of compression, and of the latent heat, through the wall of the cylinder as possible, and thus obviate superheating thereof. G is a relief valve situated in the cylinder head, which valve in Fig. 24 also forms the discharge valve, and is acted on by springs E and G¹, the first being compressed for the ordinary discharge, and the second when the safety device comes into operation. In the arrangement shown in Fig. 25, which is that used in the large machines, the relief

valve *G* is normally retained upon its seating by the powerful springs *G*¹, and the ordinary discharge or outlet valve *D* is situated centrally in the latter. *I* is the piston rod stuffing box. *K* is an oil reservoir

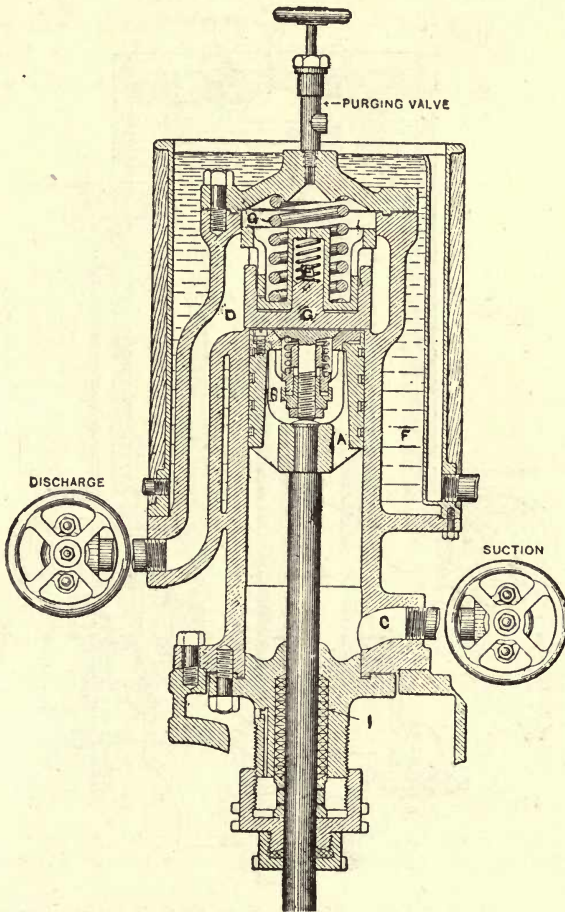

Fig. 24.—Small Single-Acting Vertical Type Frick Ammonia Compressor.
Vertical Central Section through Cylinder.

and hand pump for lubricating the piston rod, and through the small pipe and valve *L* the pump cylinder when required, which is usually only when starting a new machine, or one that has been standing for a

considerable time; the latter also serves for the attachment of an indicator, to enable indicator diagrams to be taken from the pump.

It will be seen that the compressors in question are of the single-

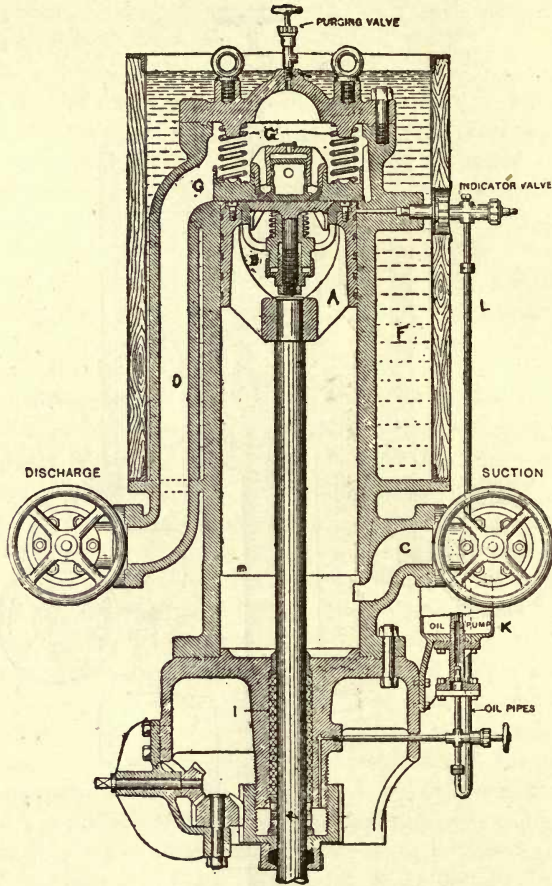

Fig. 25.—Large Single-Acting Vertical Type Frick Ammonia Compressor.
Vertical Central Section through Cylinder.

acting type, the pistons are long, and are each provided with carefully fitted rings, and the arrangement of the stuffing boxes and glands shown, moreover, is such as to render the escape of gas round the piston rods practically impossible under proper working conditions.

The two patterns of compressors are constructed upon a substantially similar principle; that shown in Fig. 24 being the form of construction employed in the case of small machines, and that in Fig. 25 in large ones. In both arrangements the discharge valve, relief valve, together with the guides, speeder, and false seat, are entirely self-contained and independent of the pump cylinder, rendering it possible to expeditiously replace the whole mechanism by a new one, or to speedily

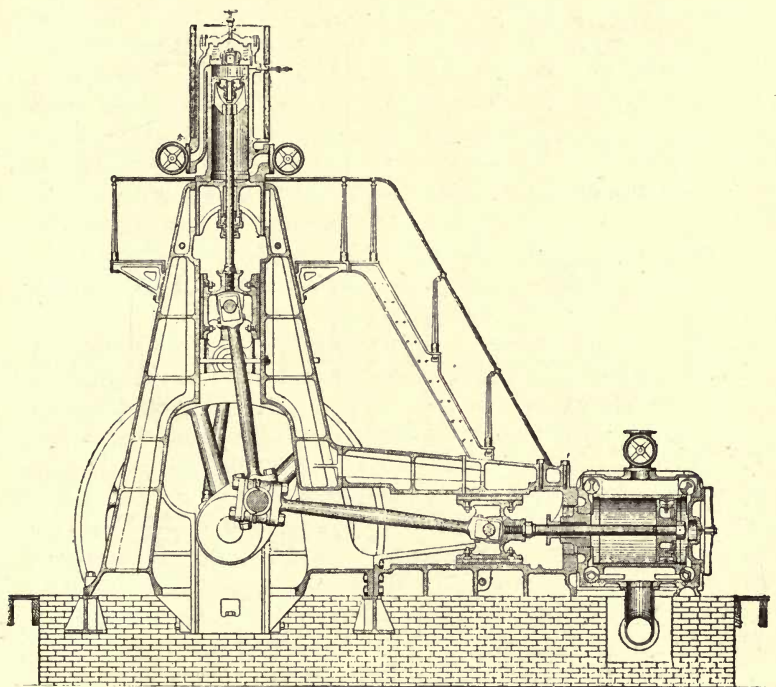

Fig. 26.—Large Single-Acting Vertical Type Frick Ammonia Compressor and Horizontal Steam Engine. Sectional Elevation of Complete Machine.

execute any necessary repairs. It will be seen that the valve mechanism can be easily got at, it being only necessary for that purpose to remove the light pump head. Fig. 26 is a vertical central section showing the complete machine.

The operation is as follows: The suction valve B being, as before mentioned, of very ample area and balanced by a spring, affords no resistance to the passage of the gas upon the return or backward stroke

of the piston, but allows of its flowing freely and rapidly into the pump cylinder, through the gas inlet *c*, under the action of the back pressure, to the vacant space above the piston. The rapid closing of the suction valve *B* at the instant of the piston beginning its forward or up-stroke is ensured by a cushion spring, and the gas is gradually compressed until it equals the condensing pressure acting upon the discharge valve in the relief valve located in the cylinder head, which then

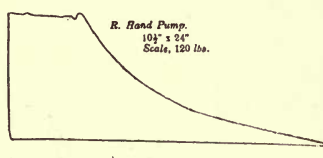

Fig. 27.

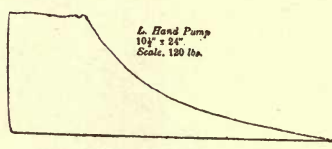

Fig. 28.

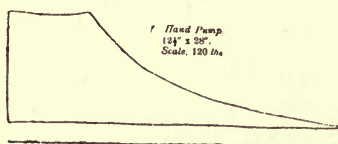

Fig. 29.

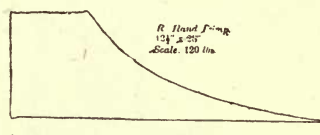

Fig. 30.

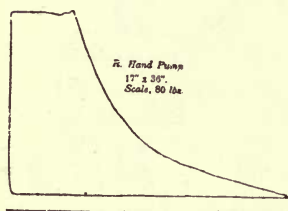

Fig. 31.

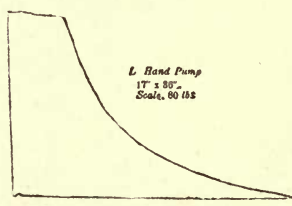

Fig. 32.

Diagrams taken from Frick Compressor.

opens to admit of its escape to the condenser. There being no clearance between the piston *A*, when at the termination of the upward or forward stroke, and the cylinder head, practically no gas remains in the cylinder to re-expand on the return or backward stroke of the piston, and destroy the vacuum.

It will be seen that it is rendered possible to do this with perfect safety, as in the event of any foreign body or obstruction getting accidentally between the piston *A* and the cylinder head, the valve or

movable portion G of the latter, which is of the full dimensions of the pump bore, will give way and allow the compressed gas to pass into the dome, and thence to the condenser, the movable portion or relief valve G being returned to its seat, under the action of the spring G^1 , and the back pressure. Under normal conditions, however, this relief action does not take place, the discharge, as already mentioned, being effected through the preliminary opening of the relief valve, or through the smaller discharge or outlet valve D , which is usually of steel, and is fitted upon a seat in the centre of the movable portion of the head or relief valve G .

Were no provision, such as the above-described relief valve or safety head G , provided, and any obstruction to become accidentally interposed between the piston and the cylinder end, not only would the latter be knocked out, and serious damage to the mechanism ensue, but the full charge of ammonia gas, which in a large machine is worth a considerable sum, would be lost.

Figs. 27 to 32 show several indicator cards taken from Frick compressors, the originals of which are in the possession of the company. It will be noticed on an inspection of these cards that they show sharp corners and straight vertical lines, which is the indication of a practically perfect non-clearance pump; furthermore, it will be seen that the horizontal lines are very straight, and the compression curves demonstrate great regularity, which latter features indicate perfect, or practically perfect, action of the valves.

In practical working spring safety heads of the type just described are apt to give trouble owing to the difficulty of adjusting the springs to work under the variations of temperature to which they are exposed within the compression cylinder, and also by reason of the liability of dirt or other foreign bodies becoming lodged upon a seating when the head is raised, and preventing it from forming a tight joint upon its return to its normal position. Mr Arthur G. Enock has endeavoured to obviate these objections, and at the same time to provide a spring safety device which will admit of the piston being worked in the compressor absolutely without clearance, and which device, being located externally to the cylinder, will be unaffected by the variations in temperature caused by compression of the working agent therein.

Mr Enock's compressor is fitted for the above purpose with the safety device shown in section in Fig. 33.

In the construction of this machine, the crosshead is provided with a short extended trunk in which is placed a powerful spring. The piston rod is provided with a disc screwed upon it which butts upon

the top of the spring, and a cap or cage encircling the piston rod is employed for attaching the latter to the crosshead trunk. The pistons

are so placed that, at the end of the compression stroke, they make metallic contact with the cylinder head, when a slight compression takes place upon the spring of the crosshead, and the lost motion is taken up at this point. This not only secures immunity from danger of knocking out the compressor head or damaging the piston and piston rod, but also allows the valve an extra moment for closing, and it will be readily seen by reference to the drawing that the back rush or "slip" of gas as the piston commences the suction stroke will be entirely prevented. In Fig. 34, which is a direct reproduction from a photograph of the actual parts, the crosshead, spring, and cap are shown removed from the machine.

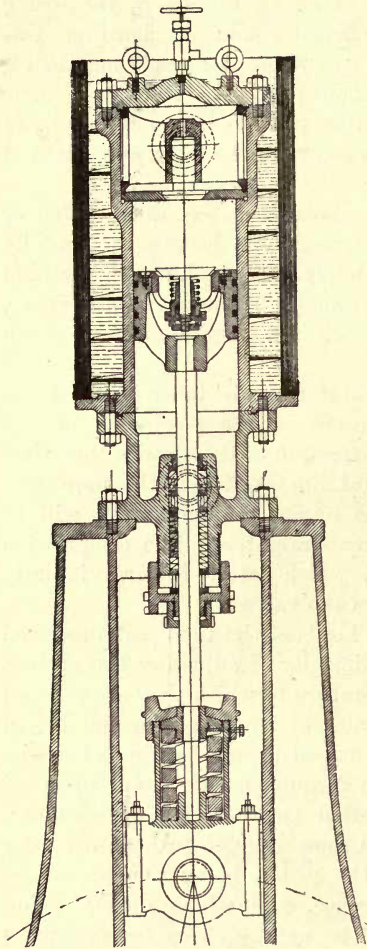

Fig. 33.—Vertical Section through Crosshead and Cylinder, "Enock" Patent Compressor.

It need hardly be pointed out that this machine should pump a good deal more gas with a given compressor capacity than is possible in any of the other types, as it would not only discharge the whole of its capacity, but it would not allow of any back leakage. This, the inventor avers, has been found to be actually the case in practical work, and to be proved beyond doubt by severe and extended trials. The crosshead trunk has vertical slots in it through which the spring can be

seen and examined, and the spring is only subject to the ordinary temperatures found in an engine-room.

The lift and fall of the suction and discharge valves are vertical, and there is consequently no lateral wear and tear of any kind, and the valves and valve seats are cut from special pieces of solid tool steel, and are consequently subject to very little hammering out.

The compressor jacket is provided with a spiral or helical annular space, through which the jacket water circulates, and considerable velocity is thus secured to the cooling water, and a much more rapid transfer of heat takes place. It is also impossible for air or gas

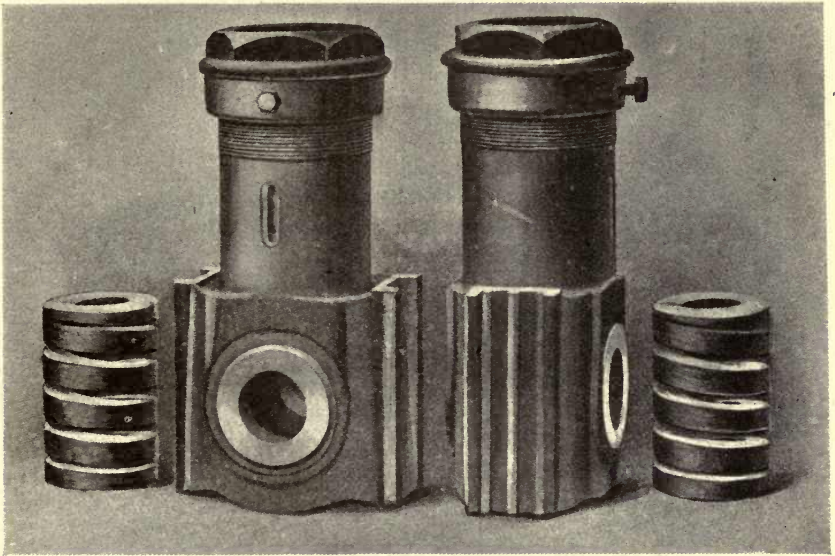

Fig. 34.—Safety Crossheads and Springs. Enoch's Patent Compressor.

bubbles to adhere to the outside walls of the compressor cylinder, and this is in itself a valuable improvement.

This safety crosshead is applicable not only to vertical machines of the type shown in our illustration, Fig. 33, but also to horizontal machines for single or double action, and where sufficient headroom is not available for vertical compressors the same type of machine is made of an horizontal pattern. It is also successfully applied to compressors of the inclosed type such as that illustrated in Fig. 35, which is suitable for refrigerating and ice-making plants on a small scale, and is made of capacities varying from one quarter of a ton to five tons of

ice per twenty-four hours. The compression machine in this case consists of two vertical single-acting ammonia compression cylinders, which are mounted upon a cast-iron body, with end covers containing the crankshaft and bearings. There are no pump rod glands to pack in this type of machine, as the evaporating gas returns from the pipe system or tank coils direct to the body of the compressors, and then flows freely through the suction valves into the compressors, the suction valves being of a special balanced type and located in the compressor

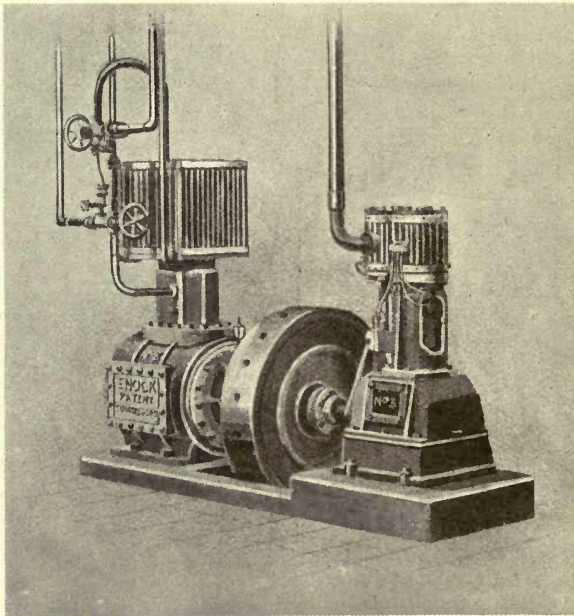

Fig. 35.—5-ton "Enock" Patent Compressor, Inclosed Type, with Coupled Vertical Steam Engine.

pistons. This construction does away with the expense and annoyance consequent on the escape of refrigerant through pump rod glands, and it also secures the operation of the machine with the smallest possible expenditure of power, on account of the absence of extensive friction upon the pump rods.

The lubrication of these inclosed compressors is automatic throughout, and the machines have been run for extended periods without any attention in this direction. The crankshaft runs in a bath of oil,

which is contained in the lower part of the compressor body, and both bearings, connecting-rod, and piston are automatically lubricated from the crankshaft.

The suction and discharge valves are so arranged that immediate access can be obtained to them by simply removing the top cover of the machine, which can be done without breaking pipe joints. The suction and discharge pipes are provided with the ordinary stop-valves and hand-wheels, and also with a set of by-pass valves and pipes so

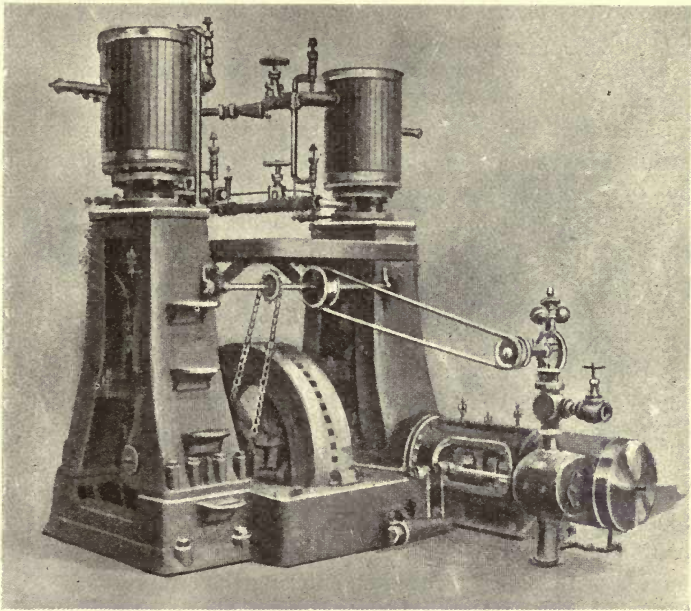

Fig. 36.—20-ton Open Type Compressor, fitted with Enock's Patent Safety Crosshead.

arranged that the refrigerant can be drawn from one part of the system and stored in another.

A certain amount of oil will always find its way out of the discharge valves in a properly lubricated compressor, but owing to the special arrangement of the crankshaft and pistons very little oil gets through in this machine. An oil separator of a special type is, however, employed as a safeguard, the gas being discharged downwards through a series of perforated baffle plates, and then rising again through the

slots in these baffle plates, which effectually separate and retain any oil which may have been discharged with the compressed ammonia. The gas itself passes out of the top of the separator, and thence into the condenser. Whatever oil is separated in this way is returned to the bottom of the compressor body by an arrangement of valves and pipe connections.

Fig. 36 illustrates a 20-ton open type of York pattern machine, fitted with the "Enock" patent safety crosshead.

As regards the position of the valves in the Enock compressor, the suction valve is placed in the piston, and the discharge valve in the pump head. By placing the valves in these positions a very large valve area is obtained, and in order to get sufficient opening for the free passage of the gas, it is only necessary for the valve to lift a very short distance. The advantages of this are twofold, the first being that while the piston is performing the downward or suction stroke the gas can flow into the pump easily and without any back pressure being set up. Second, owing to the slight lift necessary with the large valve, but little beat upon the seat takes place. The same remarks apply to the discharge valve, and with a very free passage for the discharge of the compressed gas, the pump can be worked with the least possible expenditure of power. Another point is that of the rarefaction, or otherwise, of the gas as it enters the pump during the suction stroke. In the Enock compressor the suction valve being placed in the piston and the cold gas always coming into the pump at the bottom, the entrance of the gas into the pump at the lowest possible temperature is ensured. The gas increases in volume as it increases in temperature, and if the temperature is kept as low as possible the weight of gas pumped at each stroke is greater than it would be if the gas is rarefied on entering the compressor.

Fig. 37 shows the pattern of ammonia compressors of the inclosed type adopted by Mr Enock for the machines of $32\frac{1}{2}$ tons and 65 tons.

The larger ($32\frac{1}{2}$ tons and over) machines on test show a volumetric efficiency of 97 per cent., and work almost silently. The lift on the valves is only about $\frac{1}{8}$ in. All valves and seats are cut out of solid steel, and the machines are balanced so that when required they can be run at much higher speeds. The condensers and evaporators are of the "heat-interchanger" type, the hot gas enters at the top, and the cold water enters at the bottom. Consequently the liquefied ammonia goes out at about 61° , with water going in at 60° . This is a great advantage, because on an ordinary evaporative condenser

with water going on at 60°, the liquid ammonia rarely comes off under 75°.

The same principle applies to the evaporators, which are of the double-pipe "heat-interchanger" type, the ammonia flowing through in the opposite direction to the flow of the brine. Consequently the cooled brine comes down within 2° or 3° of the temperature represented by the back pressure of the ammonia. This enables a very high back pressure to be carried for a given brine temperature.

Fig. 38 is a sectional elevation of the Enock self-oiling compressor, midget type. In this machine the gas comes in through the suction

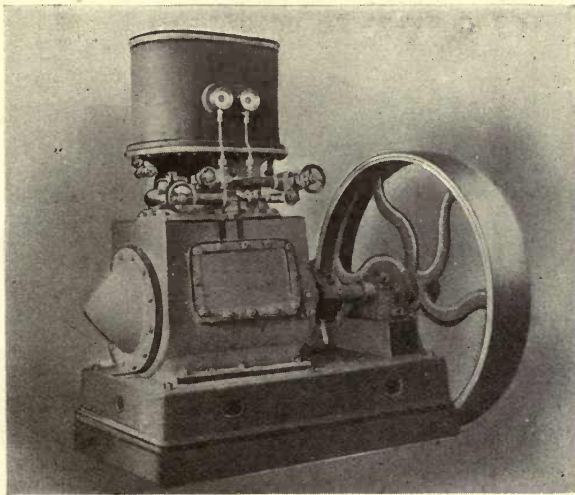

Fig. 37.—Enock Inclosed Type 65-ton Compressor.

stop-valve A down suction pipe B, and into pistons C through the holes in upper ends. As piston descends, gas passes through suction valve D and (as piston ascends) is compressed through discharge valve E, along passage F up discharge pipe F (shown partly behind suction pipe B) past discharge stop-valve G into condenser coils H. The water running over coils cools the gas and causes it to condense, and the resulting liquid ammonia passes out through small pipe J into a receiver (not shown) and is ready to do its cooling work again in the expansion coils. The crosshead spring K allows the crankshaft L to press the pistons against the discharge valve seating V, and thus to expel all the gas with perfect safety. The suction and discharge valves

can be taken out and examined with ease, and in a few minutes by taking off the top cover of the machine. Working parts are lubricated by the oil bath, which being under slight pressure also effectually seals the packing joint *n* (the only place where ammonia might other-

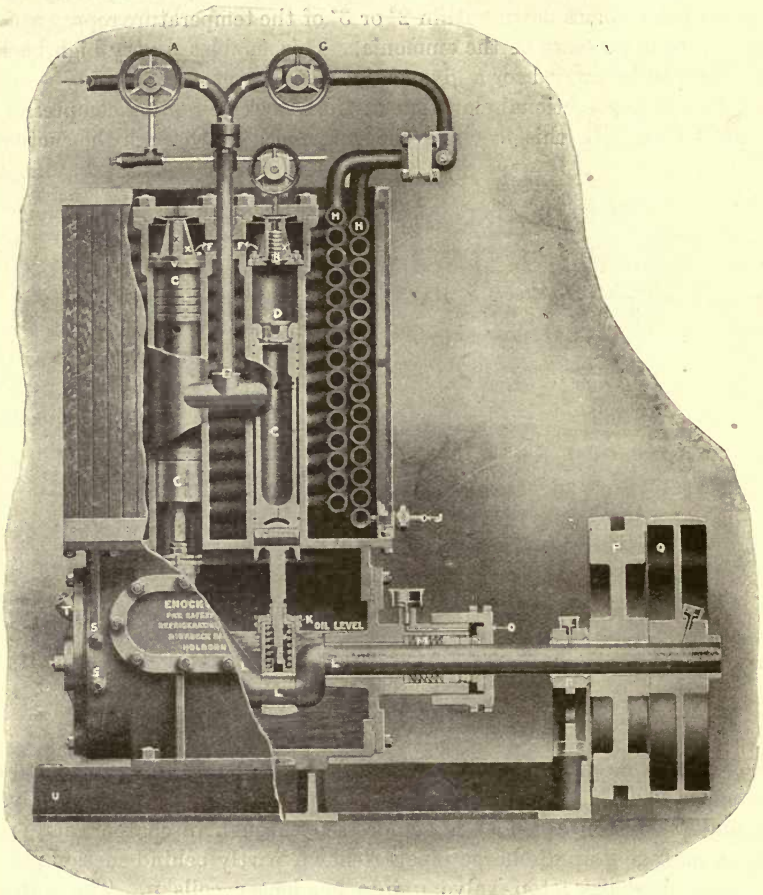

Fig. 38.—Enock Self-oiling Compressor, Midget Type. Sectional Elevation.

wise escape) and thoroughly lubricates the crankshaft bearing. The packing bush *n* is pressed up by the packing nut *o* which is threaded, and cannot be set up unevenly like an ordinary gland bush. The fly-wheel *p* and loose pulley *q* are supported by an extra bearing *r*,

so no strain ever comes on the packing *m*. Two plugs, *ss*, are provided for finding height of oil in bath without opening up chamber, and no gauge glasses are necessary. Oil is put in at plug *t*. The feet of machine and outer bearing are planed on underside and mounted on a strong rigid cast-iron bed plate *u*, the whole being very compact.

The ammonia compression machines designed by Carl Linde, and first patented in 1870, are extensively used, and this type of machine is said to give very good results.

In the Linde compound ammonia compressor the high and low pressure pistons are both coupled to the same piston-rod, and an intermediate chamber connected with the suction and back pressure

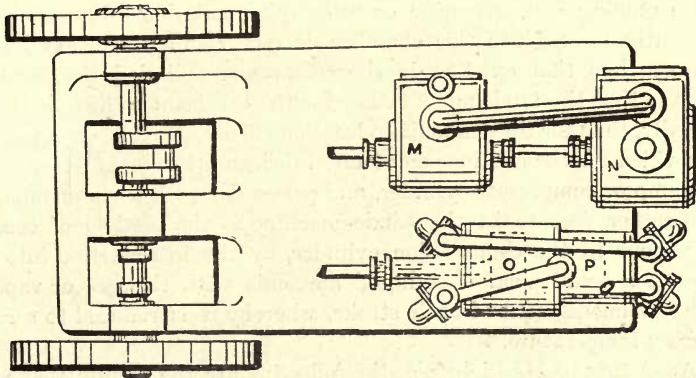

Fig. 39.—Linde Horizontal Type Compound Ammonia Compressor and Compound Steam Engine. Plan View.

side connects the cylinders. The pressure of the gas at its intermediate stage is conducted by a suitable pipe from the front of the low pressure piston to the rear of the smaller cylinder, where it acts on the smaller piston in the reverse direction, and directly balances an equal area of the large piston.

Fig. 39 is a plan view showing a compound ammonia compressor, combined with a compound steam engine. In the drawing *m* is the high pressure cylinder, and *n* the low pressure cylinder of the compound steam engine, and *o* is the low pressure cylinder, and *p* the high pressure cylinder of the ammonia compressor.

In this machine it will be seen that the entire power of the engine is applied to one crank, and the compressor is driven off the other

crank. This arrangement entails the provision of a very powerful crankshaft and bearings to admit of its safely withstanding the double strain to which it is thus subjected during work. An objection to the arrangement is the additional amount of friction to which it gives rise.

A type of Linde machine, intended especially for land installations, comprises compound ammonia compressors, arranged in line horizontally and driven from a crank upon a crankshaft placed centrally between the two compressors, and at right angles thereto. The necessary motion is imparted to the crankshaft by means of a tandem compound jet-condensing engine.

The method employed by Linde to prevent leakage of gas past the piston rod stuffing box and gland, is to provide a chamber or recess in the stuffing box, glycerine or some other suitable lubricant being constantly forced into this chamber or recess at a somewhat higher pressure than that existing in the compressor cylinder, the result of which is that the tendency is rather for the lubricant to leak or escape inwardly, than for the ammonia to leak outwardly. A suitable separator is provided for the elimination of any lubricant that finds its way into the pump or compressor cylinder, and passes out with the ammonia.

Another feature in the Linde machine is the method of cooling the vapour in the compression cylinder, by the introduction into the latter of a small portion of liquid ammonia with the gas or vapour, at the commencement of each stroke, whereby it is reduced to a refrigerating temperature.

According to Mr Lightfoot, the following are the results that were obtained from tests made, in an exhaustive and impartial manner, by a committee of Bavarian engineers, with an ammonia compression machine constructed on the Linde system, and erected in a brewery in Germany :*—

| | | |
|---|---|-----------------|
| Nominal capacity of machine, ice per 24 hours - | - | 24 tons |
| Actual production of ice, per 24 hours - | - | 39·2 tons |
| " " " per hour - | - | 3,659 lbs. |
| Heat abstracted in ice-making, per hour - | - | 731,800 units.† |
| Indicated horse-power in steam cylinder, excluding that required for circulating the cooling water, and for working cranes, &c. - | - | 53 I.H.P. |
| Indicated horse-power in ammonia pump - | - | 38 I.H.P. |
| Thermal equivalent of work in ammonia pump, per hour | - | 97,460 units.† |

* *Proceedings, Institution of Mechanical Engineers*, 1886, p. 218.

† A thermal unit is the amount of heat necessary to raise the temperature of 1 lb. of water 1° by the Fahrenheit scale when at 39·4°. Mech. eq. 778 ft.-lbs.

| | | |
|--|---|-------------|
| Ratio of work in pump to work in ice-making - | - | 1 to 7.5 |
| Total feed-water used in boiler, per 24 hours - | - | 26,754 lbs. |
| Ratio of coal consumed to ice made, taking an evaporation of 8 lbs. of water per lb. of coal - | - | 1 to 26.3 |

The pumps were driven by a Sulzer engine, developing 1 I.H.P. with 21.8 lbs. of steam per hour, including the amount condensed in the steam pipes.

The Linde machine, as built in the United States, shows several constructional differences as compared with the first type of machine

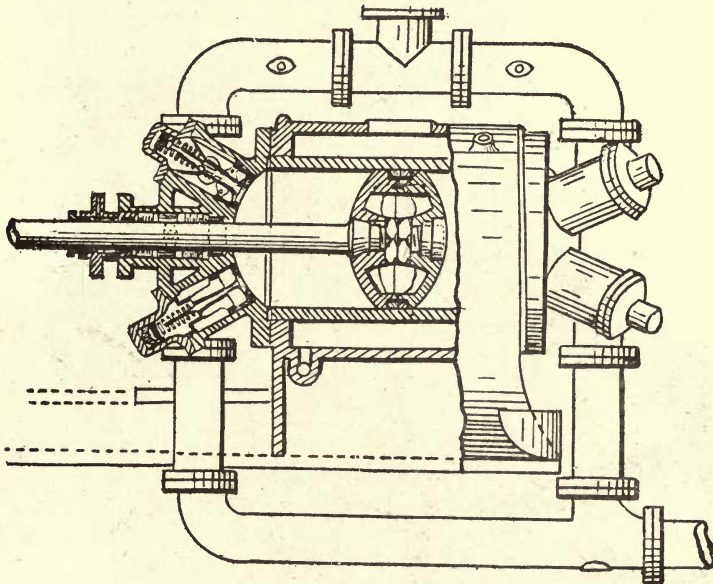

Fig. 40.—American Pattern, Linde Horizontal Type of Ammonia Compressor. Part Sectional View.

made in Germany. Fig. 40 is a sectional view illustrating the most recent design of Linde compressor cylinder, as made by the Fred. W. Wolf Co., of Chicago, U.S.

The pattern of machine made by the Vilter Manufacturing Co., of Milwaukee, U.S., consists of either one or two horizontal double-acting ammonia compressors driven by a horizontal Corliss engine, the engine and compressor cranks being keyed on the extremities of the crankshaft at angles to one another, so as to cause the highest gas pressure in the compressor to take place at the time when the

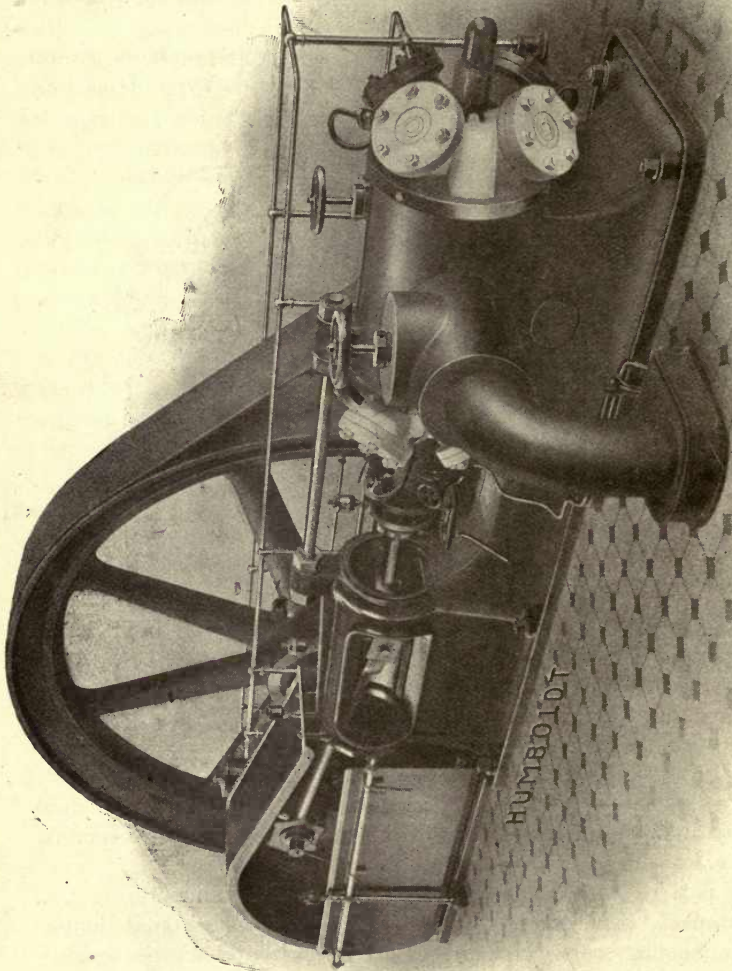

Fig. 41.—Horizontal Type of Belt-driven Humboldt Ammonia Compressor.

highest steam pressure is acting on the engine. The ammonia compressor is cast with slides and pillow block all in one piece. The wearing surface of the compressor consists of a cylindrical bushing or lining which is forced into the water jacket after the latter is bored. Four ammonia compressor valves are located in the two circular heads, the latter fitting into recesses and being packed with metallic packing. The suction and discharge valves are rendered noiseless in action and their life considerably prolonged by the provision of gas cushions. The compressor plunger is fitted with self-adjusting packing rings and also bull rings, and the piston and follower are turned circular to exactly fit the front and rear heads of the compressor, and thus to reduce the amount of clearance as far as practicable, the plunger rod being, moreover, adjustable lengthways, thus admitting of an equal division of the clearance being made, and the wear of the crank and crosshead boxes being taken up when desired.

Leakage of gas past the piston or plunger rod is prevented by a stuffing box and gland fitted with a metallic packing, held in position by a long sleeve, oil being circulated through the latter by means of an automatically operated oil pump, and the oil acting both to lubricate the piston or plunger rod, and to form a seal to prevent the escape of ammonia. A separate support bolted to the frame of the compressor holds the outer extremity of this hollow sleeve in place, a packing being provided at the outer end of this support for retaining the oil.

By-passes are provided between the suction and discharge pipes in close proximity to the compressor, thereby admitting of the valves being operated for pumping out the condenser.

Wedge adjustable shoes are provided in the crossheads, and the connecting rods are fitted with solid heads, the former having a solid brass box, and the crankpin a brass box lined with babbitt metal, wedge adjustment being provided in both instances.

Fig. 41 shows an ammonia compressor made by the British Humboldt Engineering Co., Ltd. The valves of this machine are of the well-known Humboldt pattern, which construction has for many years past given good results in practical working. The stuffing box is fitted with metallic packing, and a special injection device is provided for the freezing agent, by which arrangement, amongst other advantages, a cool stuffing box is ensured.

The Fixary compressor is shown in vertical central section, some of the parts being left in elevation in Fig. 42. It consists of two vertical, single-acting cylinders A, B, having an equalising chamber C, situated

between them, at the upper extremity of which is provided a small valve governing an aperture leading to the suction side of the compressor. In the upper extremity of each of the cylinders A, B are provided two valves, that on the right-hand side opening inwardly and being the suction or inlet valve, and that on the left-hand side opening outwardly and being the outlet or delivery valve. The space below the pistons is filled with oil which lubricates the pistons, whilst at the same time preventing the gas from escaping past them to any

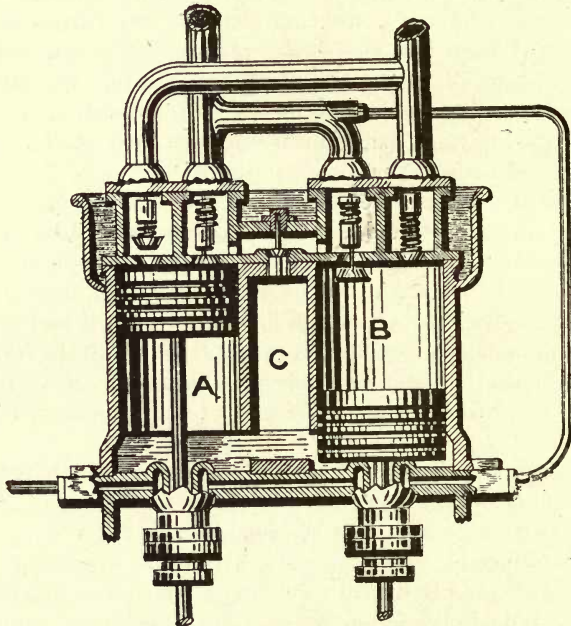

Fig. 42.—Two-Cylinder Single-Acting Fixary Compressor.
Vertical Central Section.

great extent. Any gas that does find its way beneath the pistons passes into the equalising chamber c, where any accumulation of it is drawn off by the compressor, through the small valve in the upper extremity thereof, and one or other of the suction or inlet valves, and again returns to the system through the outlet or delivery valves. The oil that may be carried through the valve in the equalising chamber serves the purpose of sealing the valves and filling up the clearance spaces.

The characteristic feature of the Neubecker system is the special device for preventing leakage taking place round the piston rod. To effect this, the stuffing or gland box, through which the piston rod passes, is so enlarged as to form an annular recess or chamber surrounding the rod, which chamber is partly filled with oil, and maintained at a corresponding pressure to that prevailing in the surrounding atmosphere, by means of a compensating chamber, which latter is connected at its upper extremity to a small auxiliary pump through a pipe, the inlet to which is governed by a valve connected to, and controlled by, a metallic diaphragm, the upper side of which diaphragm is exposed to the pressure of the atmosphere.

The operation of this compensating chamber is as follows:—The gas which may escape into the stuffing box chamber passes into the compensating chamber, and as soon as sufficient has thus accumulated to raise the pressure therein above that of the atmosphere, it acts upon the flexible diaphragm to expand it outwardly, and thereby open the valve communicating with the above-mentioned auxiliary pump, by which the gas is drawn off or removed and delivered into the refrigerator. The pressure in the separating chamber then again falls below that of the atmosphere, and the diaphragm being forced inwardly by the atmospheric pressure, the outlet valve closes. The lower portion of the compensating chamber forms a well, wherein any oil that leaks past the piston rod gland of the compressor, as also that coming from the separator, accumulates, and is heated by a steam coil or worm, so as to drive off any gas that has been absorbed by the oil, after which the latter is drawn off from the bottom of the compensating chamber to be cooled and filtered for further use.

Various patterns of ammonia compressors are constructed by the Pulsometer Engineering Co., Ltd., on their improved system, ranging from 1 ton ice-making capacity per twenty-four hours, up to installations on the same principle, with a capacity for an output up to 25 tons of ice or more per day of twenty-four hours.

In a type of apparatus particularly suited for export, everything, including the steam engine, compressor, gas condenser, refrigerator, and ice tank, is mounted on one continuous bed, all the ammonia connections are ready made, and the whole can be readily put in one case and sent abroad, all that is necessary on its arrival being to charge the machine with gas and the ice tank with brine.

In the case of a small machine of 1 ton ice-making capacity, such as that first mentioned, either a vertical high-pressure engine, or an horizontal one, or any other suitable motor, is employed; for

larger sizes, however, these makers prefer to use cross compound condensing engines of the horizontal type, and of extra size to provide an ample margin of power in hot weather, and to give the best results as to saving in steam consumption from an early cut-off, and each engine driving a compressor tandem. The engine condenser is generally made of the surface condensing type, and, together with the water circulating pump, placed between the engines and driven from the low-pressure crosshead. This arrangement has been found in practice to be, with long strokes of, say, at least 30 in., most reliable, and it

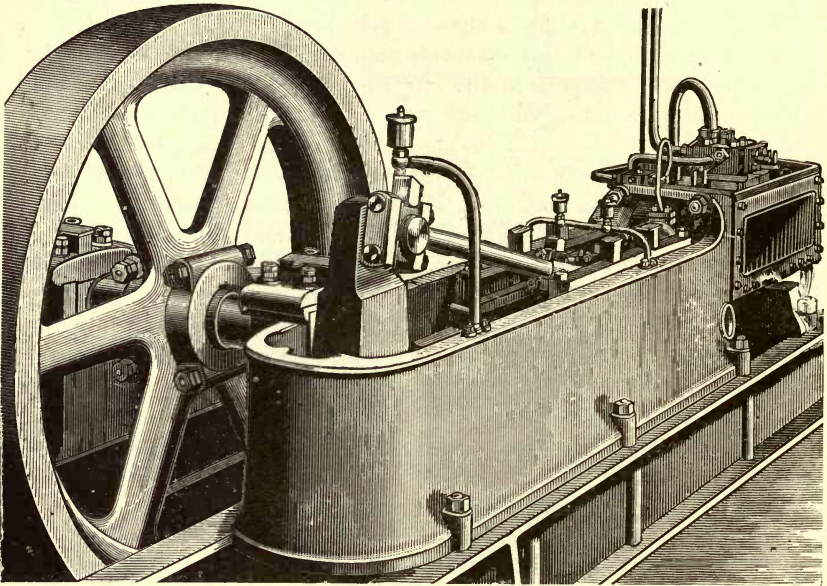

Fig. 43.—Horizontal Double-Acting Ammonia Compressor, Pulsometer Engineering Co., Ltd.

admits, moreover, in the event of an emergency, of running at a high speed. In cases where the very highest economy is desirable, triple or quadruple expansion engines are desirable.

Fig. 43 illustrates one of a pair of pumps employed in a brewery and having a cooling capacity of one hundred barrels per hour. As will be seen from the drawing the ammonia pump is of the double-acting type, and is arranged horizontally. It is intended to be driven from any convenient source of power already extant in the brewery. To obviate leakage and loss of ammonia gas, the stuffing box is fitted

with a special oil-lubricating arrangement, by means of which a gas-tight joint is secured without any necessity for screwing up the gland so as to grip too tightly. The valves work without any springs or buffers, and in the larger sizes are so arranged that they can be adjusted from the exterior; they are also of ample area, thereby reducing the pressure on the pump, and preventing the latter and the engine from being overworked.

The condenser is fitted with sets or series of lap-welded tubes, which are subjected to high tests both by hydraulic and air pressure, and are secured in a special arrangement of return heads or ends of forged steel. The inlet and outlet valves are also of forged steel.

The evaporator or refrigerator consists of a welded steel shell, having hammered steel tube plates into which are fitted lap-welded tubes (subjected to a similar test to those of the condenser) in such a manner that they can be readily withdrawn from the shell for inspection or renewal, and the whole is fitted in a tank with suitable brine pump connections. The inlet and outlet tubes are likewise of forged steel.

The makers prefer the use of sets or series of tubes in their condensers, and refrigerators, to that of coils or worms, for the following reasons. That coils or worms are usually made in long lengths with a number of welds, consequently should such a tube at any time exhibit signs of weakness it would entail a heavy expense to renew it, both on account of the weight of metal and the difficulty of replacement. In a refrigerator, in addition to the above, the use of a coil gives rise, according to them, to a tendency to prime, and thus cause damage to the pump, and there is, moreover, they say, considerable trouble in bringing the brine into such intimate contact with the outer surfaces of the tubes as is advisable.

When desired, an arrangement can be fitted to this ammonia compression machine, by means of which the ammonia can be pumped from the refrigerator into the condenser or *vice versa*, or, if desired, out of the machine altogether.

An advantage of no small importance possessed by this apparatus is that of the utmost simplicity of construction, thus considerably facilitating the management. The workmanship and design, moreover, are calculated to ensure the attainment of the greatest strength and of the maximum durability possible.

Fig. 44 is a perspective view illustrating a small single-acting vertical ammonia compressor and condenser, constructed on the Kilbourn inclosed type system. In this installation the machine is intended to

be driven by a gas engine, or other suitable source of power, and it is designed for cold storage on the direct expansion system. The floor space occupied is small, being only for the entire plant, including a gas engine of 4 N.H.P., 12 ft. by 4 ft. 6 in., and the machine is capable of maintaining a storage capacity of from 8,000 to 10,000 cub. ft., at a suitable temperature for frozen mutton, or, with the necessary appliances, of making $2\frac{1}{2}$ tons to 2 tons of ice per twenty-

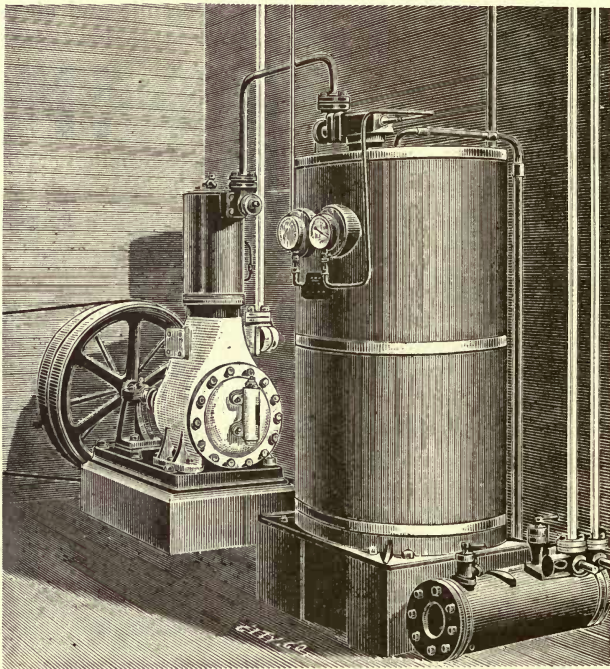

Fig. 44.—Small Vertical Single-Acting Kilbourn Inclosed Type Ammonia Compressor and Condenser.

four hours. The condenser and refrigerator are composed of lap-welded iron coils fitted in steel or wrought-iron shells.

The late Mr J. K. Kilbourn, C.E., was the inventor and patentee of a number of improvements in, and connected with, refrigerating machinery, his chief speciality being, however, marine refrigeration, he having had a wide experience in this direction, and several marine types of ammonia compression machines, constructed on his system,

will be found described and illustrated in the chapter on Marine Installations.

Fig. 45 is a sectional view of the Triumph Ice Machine Co., Cincinnati, O., U.S., horizontal pattern double-acting ammonia compressor. It will be seen from the illustration that the compressor is provided with five valves, viz., three suction valves and two discharge valves, the third, or auxiliary suction valve, being much lighter than the main valves, and perfectly balanced, and it being claimed by the makers tending greatly to increase the economy of the machine.

Obviously the main suction valves must necessarily be of sufficient dimensions to admit the charge quickly at the commencement of each

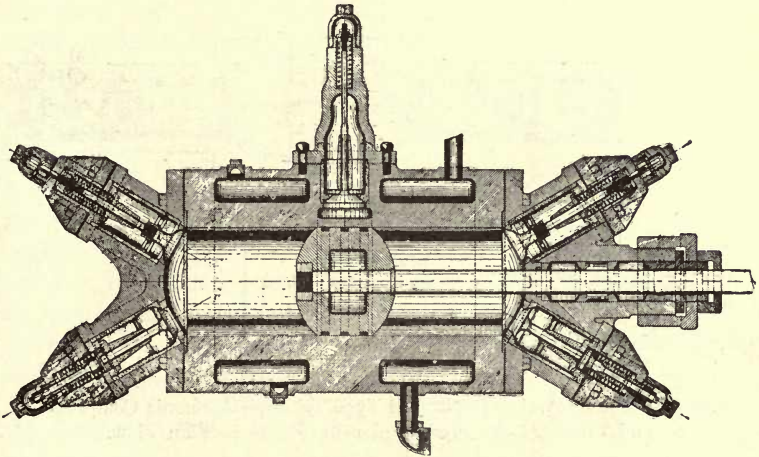

Fig. 45.—Double-Acting Horizontal Type Triumph Ammonia Compressor. Sectional View.

stroke, and the springs controlling them must consequently have an appreciable tension. It will be readily seen that owing to this fact the pressure of the gas in the cylinder, during admission, must be less than it is in the suction pipe by an amount equal to the tension of these springs. By the use of the above-mentioned third, or auxiliary suction valve, which is comparatively light, and is consequently operated with a very light spring, the pressures in the compressor pump are equalised, and a fuller charge is obtained at each stroke, thereby increasing the efficiency of the machine.

The valves comprise each a guard screwed on to the stem, fitted inside a cage, and so ribbed as to reduce the port area, the bottom of

the stem being enlarged for that reason. Stems extending from both the suction and discharge valves to the exterior, and passing through stuffing boxes, admit of their being adjusted from the outside, and any desired degree of tension being put upon the springs. The object of this arrangement is to adjust the machine for working at different pressures, and the relative temperatures thereof.

There are three packing compartments in the piston rod stuffing box, and it is fitted with a suitable relief valve communicating with the suction. The heads are formed concave, and of a radius which enables a larger valve area to be secured. The principal shut-off valves are of such a form of construction as to admit of their being packed whilst the machine is working, and a feature in the design of

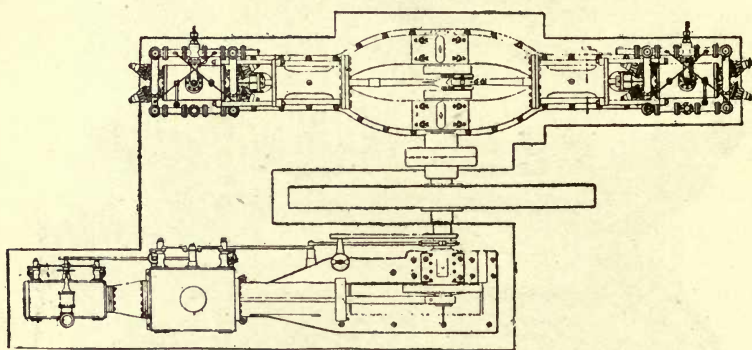

Fig. 46.—Double-Acting Horizontal Type Triumph Ammonia Compressor and Tandem Compound Condensing Engine. Plan View.

this machine, which is of by no means inconsiderable advantage, is that every portion of the compressor is easily accessible.

Fig. 46 is a plan view showing a double-acting compressor, coupled direct to a tandem compound condensing steam engine. This machine is of 400 tons capacity, and comprises the features already described with reference to Fig. 45. It is so arranged that each cylinder can be operated, single or double-acting, on either end. A separate crank and outer bearing are provided, thereby adding considerably to the strength of the shaft. Another point of construction which is of considerable advantage is that the whole machine is arranged on a straight line, thereby giving great strength and rigidity. It is also claimed by the makers that there is no breathing of the cylinder in this construction, and that a great deal of unnecessary clear-

ance is not allowed to take place at each compression stroke of the machine.

The main feature of novelty claimed in the ammonia compressor invented by Thomas Bell Lightfoot, and for which he obtained a patent in 1885, is that compression is effected at one side only of the piston, the other side being exposed merely to the pressure of the vapour as drawn in from the refrigerator. The suction valve is placed concentrically within the piston, and the delivery valve within the cylinder cover.

The main distinctive feature of the Pictet machine is the means adopted for preventing superheating of the ammonia gas during compression in the cylinder of the pump, and the loss that would ensue therefrom, which, were there no means employed for its reduction, might amount to as much as 30 per cent. in a double-action compressor. In some arrangements, as has been already mentioned, provision is made for effecting this by injecting a small quantity of liquid into the compressor, which liquid in evaporating maintains the gas or vapour in a condition of saturation, thereby admitting of the compression being effected under such conditions as to approximate more closely to the isothermal function; in others, again, the compressor cylinder is water-jacketed for a like purpose. In the Pictet machine, however, in addition to a water jacket round the compressor cylinder or barrel, the piston and piston rod of the compressor are likewise formed hollow, and through this space a constant stream of water is kept circulating for cooling purposes.

The results obtained by this arrangement are much lessened by the great thickness of metal that is required in the parts. The loss in a well-jacketed and water-cooled compressor, according to the experiments* of Professor Denton, amounting to 21.4 per cent., and where less efficiently jacketed the loss may rise to about 25 per cent.

In the specification of a patent granted to Raoul Pictet in 1887 he describes an improved vessel or compartment for use in a refrigerating apparatus, wherein the volatile liquid employed is subjected to evaporation so as to produce cold, which refrigerates brine or other non-congealable liquid surrounding the evaporating compartment. The improved cooler or refrigerator is claimed to be suitable for use with either a compression or an absorption machine, and consists of two tubes arranged horizontally, and connected at their extremities by bent tubes, and at their lower sides by pendant U-shaped tubes, which latter are preferably secured by means of solder joints to sockets

* *Transactions, American Society of Mechanical Engineers*, vol. xii.

brazed on the tubes, and are further connected with each other by conducting bands.

In the latter part of 1887 a patent was obtained by Samuel Puplett and Jonathan Lucas Rigg for improvements in refrigerating machines, and several further improvements have since been added by Puplett.

The main features of the 1887 patent, which are equally applicable

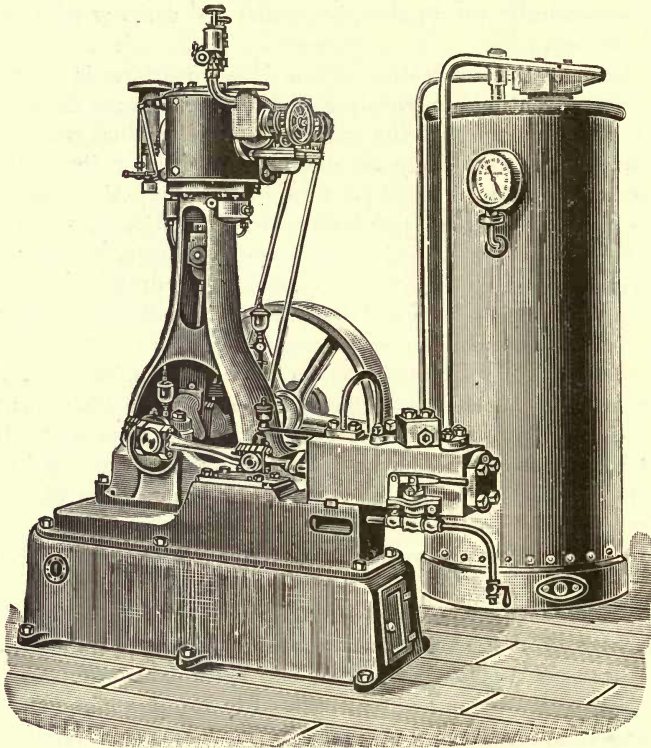

Fig. 47.—Double-Acting Puplett Ammonia Compression Machine.

to any ice-making and cooling apparatus wherein any one of the condensable gases is used as a frigorific agent, are as follows:—

The provision of chambers or reservoirs either situated directly at the bottom of, and communicating with the inlet valve chests, or in any other suitable position, and connected thereto by means of pipes. These chambers or reservoirs serve to receive the oil which finds its way into the cylinder of the compressor pump, principally round the

piston rod, and which would otherwise accumulate beneath the valves. To the undersides of the chambers or reservoirs are fitted draw-off cocks, by means of which the oil may from time to time be withdrawn whilst the machine is in motion, and without any appreciable loss of gas or admission of air taking place.

Complete liquefaction of the gas is ensured by carrying the return liquid pipe between the condenser and refrigerator through the refrigerating or ice making tank or box, instead of outside the latter, as is usually done, thus utilising the low temperature of the brine to complete the condensation of the gas.

In Fig. 47 is illustrated a modern type of Puplett ammonia compression machine especially designed for use in breweries for cooling worts and yeast rooms.

The cooling capacity of this machine varies from 20 barrels of worts per day to 200 barrels per day, and the horse-power required from 3 up to 12, in accordance with the size of the machine. The apparatus can be connected to existing hot and cold liquor backs and collecting tanks.

Sir Alfred Seale Haslam took out a patent in 1894 for an improved compressor especially intended for use with refrigerating machines, and particularly applicable to compound compressors wherein the gas is compressed in

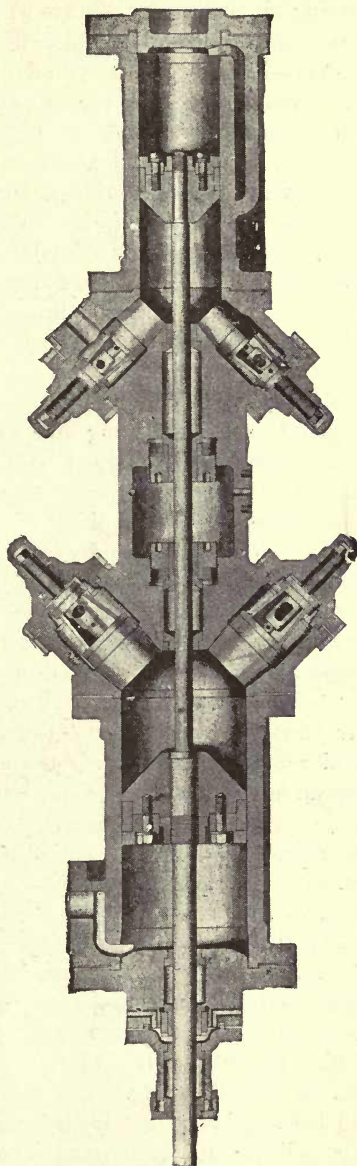

Fig. 48. — Horizontal Type Compound Haslam Ammonia Compressor. Vertical Central Section.

stages. The objects of the invention are to prevent the gas from escaping or coming in contact with the air, and to avoid dead spaces in the apparatus. The chief novel features are claimed to be as follows:—First, a pump cylinder having a chamber at one or both ends through which the piston rod passes, and which is kept supplied with lubricating and sealing liquid from a reservoir through which the gas to be compressed also passes. Second, two single and double acting pumps arranged tandem to each other, and with the compression ends of their cylinders next each other, and having between them a chamber supplied with lubricating and sealing liquid, through which their common piston-rod passes. Fig. 48 shows this machine in vertical central section through one of the ammonia compressor cylinders, drawn to an enlarged scale, and illustrating the self-sealing oil chamber.

The operation of this compressor is as follows:—After adjusting the glands of the receiving and separating vessel, the latter, and the central chamber, is charged with lubricating and sealing fluid to a suitable height. The gas is then drawn through the supply pipe, accompanied by the requisite amount of the lubricating and sealing fluid, which latter is admitted to the low-pressure cylinder by a cock or valve, through the suction valve, and compression to the desired extent is then carried out.

Fig. 49 shows a Haslam machine having one double-acting compressor driven by a compound drop-valve steam engine. The compressor is of the standard Haslam type, with two suction and two delivery valves in each cover. The trunk form of guide is found to give great rigidity and ensure perfect alignment. The steam engine is of the Haslam latest drop-valve type, having governor regulated inlet valves on the high-pressure cylinder. The machine shown in the illustration has recently been built for a large meat freezing works in South America. The compressor is $22\frac{3}{4}$ in. by 40 in. stroke. An independent steam surface condenser and ammonia condenser of the evaporative type are usually supplied with machines of this class.

Fig. 50 illustrates a Haslam horizontal machine with compound engine and two ammonia compressors of the double-acting type. The arrangement of the steam engine valve gear, with the governor controlling the inlet valves of the high-pressure cylinder, will be clearly seen in the engraving. The low-pressure cylinder is steam-jacketed, and both cylinders are lagged and covered with planished steel, and have polished iron caps over the end covers. If desired, one compressor may be worked while the other is being overhauled.

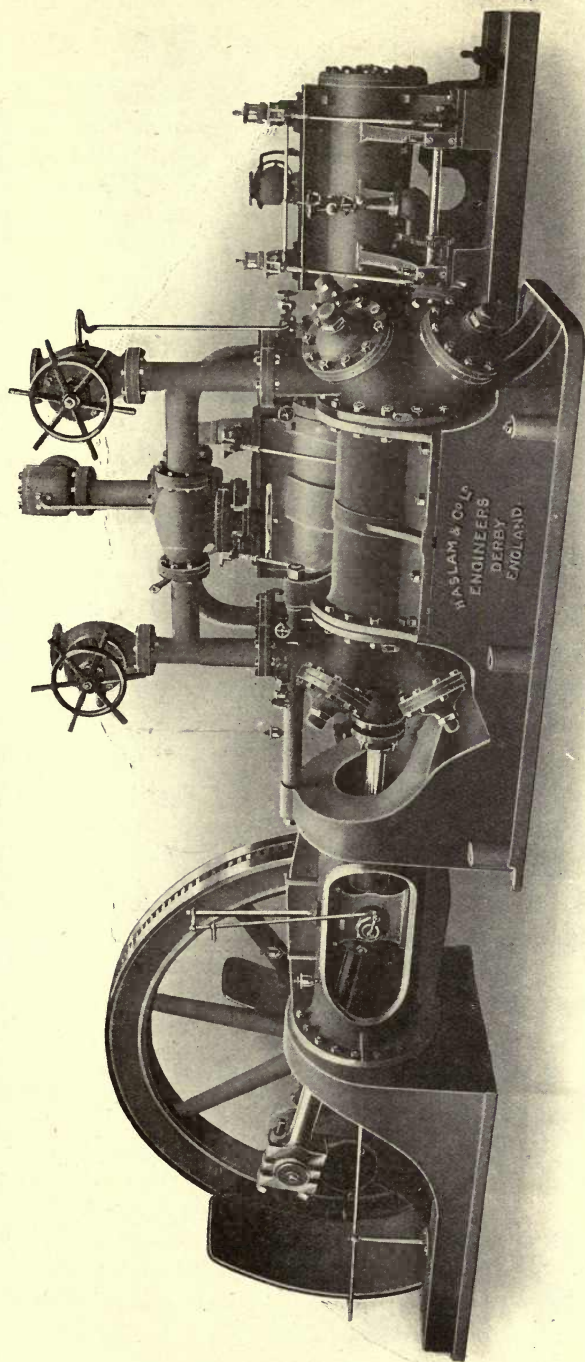

Fig. 49.—Horizontal Type of Haslam Double-Acting Ammonia Compressor with Compound Drop-Valve Steam Engine.

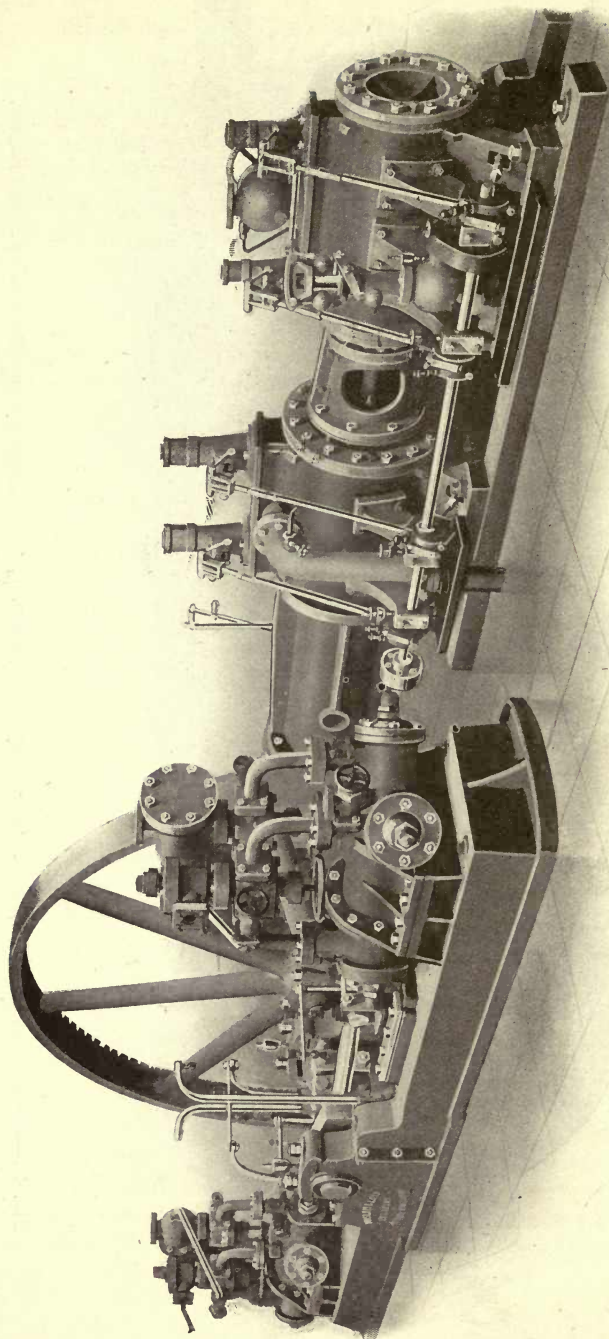

Fig. 50.—Horizontal Type of Haslam Double-Acting Ammonia Compressor with Compound Drop-Valve Steam Engine.

Fig. 51 shows a Haslam horizontal compound ammonia machine which is specially suitable for working in hot climates, where the temperature of the water used for the ammonia condensers is high. The steam engine is of the compound "drop-valve" type, and drives two compressors from the tail rods, arranged to compress the ammonia gas in two stages. The low-pressure ammonia compressor is of the double-acting type, and the high-pressure ammonia compressor is of the single-acting type, so that the gland is only subject to the intermediate pressure. The machine from which the illustration is taken has for some years been making ice at Singapore, and has given excellent results.

Amongst the pioneers of refrigerating machinery in the United States was Mr David Boyle. The modern type of Boyle ammonia compressor consists of two vertical single-acting pumps arranged in combination with a vertical or an horizontal engine. The compressor valves are mounted in removable valve boxes, and both the suction and discharge valves are situated in the upper head, where they are held in place by cross-bars and a set-screw to each of them. There is a division in the centre of the head. The gas being delivered through its pipe, which is secured in an extension on the cylinder communicating with the inlet chamber, enters the cylinder through its valve on the downward stroke of the piston. The gas is compressed upon the upward or return stroke of the piston until such time as it becomes equal to the pressure in the condenser, when the discharge valve in the opposite side of the head rises and permits the discharge of the gas through the valve and communicating chamber to the compressor discharge pipe, to take place.

The suction chamber likewise communicates with the lower end of the cylinder of the compressor so as to allow the latter to be filled with gas during the upward stroke of the piston, and to permit its escape therefrom during the downward stroke of the piston. A solid pattern of piston fitted with a number of snap-rings having sufficient tension to prevent any leakage of gas, is employed, and the piston rod stuffing-box gland is adjustable through a worm and worm-wheel arrangement by means of a hand-wheel from the exterior.

A water jacket surrounds the upper part of the compressor cylinder, and an inlet and outlet admit of a constant flow of water being maintained through the same.

The York Manufacturing Co., of York, Pa., U.S., are makers of compound ammonia compressors in which all the gas has to be drawn through the suction valves, and these latter have to divide the space

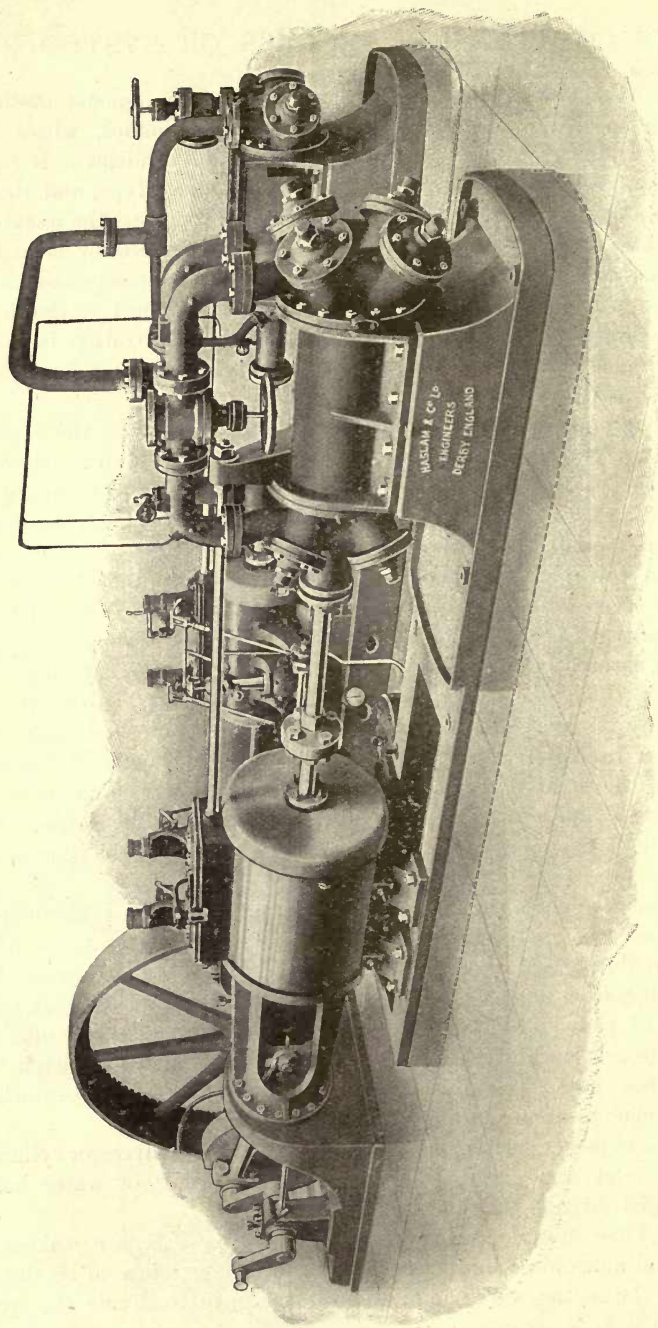

Fig. 51.—Horizontal Compound Type of Haslam Ammonia Compressor with Compound ‘Drop-Valve’ Steam Engine.

on the heads of their cylinders together with the delivery valves, being consequently limited in dimensions. When the compressors are of large size the gas is passed through a condenser between the two stages of compression for the purpose of abstracting a portion of the heat, reducing the volume and saving power. The connecting pipes are located on the top, and in some instances a tubular condenser is provided, which arrangement is said to give good results. The valve in the low-pressure cylinder is formed annular, and, therefore, requires only about half the lift of a mitre valve in order to give the same discharge opening.

These makers arrange their compressor cylinders vertically, but they employ in combination therewith both vertical and horizontal steam engines.

The medium-sized machines are made with two low-pressure cylinders placed on the outside, and one high-pressure cylinder placed between them. The crankpins of the low-pressure pistons are all in line, and the high-pressure crankpin on which the horizontal engine works is placed at 180° .

In the case of the very large-sized machines four compressor cylinders are arranged in a row, and are worked by four cranks, the two outside ones of which are high pressure, and the two intermediate ones between these being low pressure. The two connecting rods from a cross-over compound engine each operate respectively one of the outer cranks. The fly-wheels are overhung, and the pipes from the cylinder heads connect the high and low pressure cylinders through a condenser or cooler.

This company also build single-acting compressors, and in Fig. 52 is shown one of their latest designs of a vertical type of single-acting machine. A large type of compressor constructed by them, and having a capacity of 400 tons refrigeration, has two single-acting ammonia pumps 30 in. in diameter by 48 in. stroke, and driven by a horizontal cross compound condensing engine, having a high-pressure cylinder of 30 in. diameter, and a low-pressure cylinder of 58 in. diameter by 48 in. stroke, the crankshaft being provided with two throws and four bearings, and the fly-wheel being in the centre of the bed-plate between the two cranks. The weight of this machine is over $178\frac{1}{2}$ tons.

The vertical type of ammonia compressor made by the Remington Machine Co., Wilmington, Del., U.S., is of the single-acting inclosed crank pattern, the crankshaft extending through one side of the casing only, and being fitted with a single stuffing box on that side, and a central bearing, so as to render the construction more rigid. In

the bottom of the casing is an oil bath into which the cranks dip, and the central bearing is at all times flooded with oil. There are two cylinders, cast in one, and fitted with heads carrying the suction and discharge valves mounted in cages. The heads of the two cylinders are connected on the suction side to a strainer-box for intercepting any dirt or foreign matter, and the discharge side is connected with

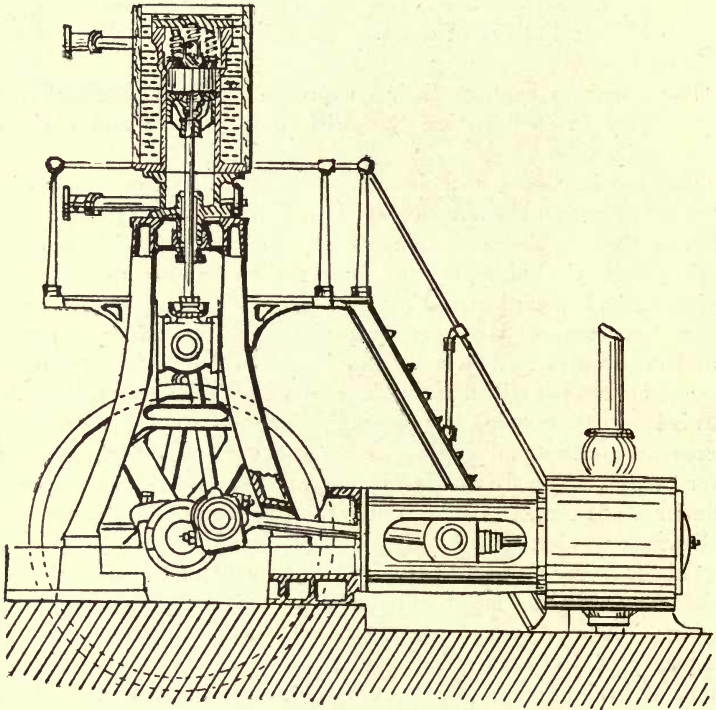

Fig. 52.—Single-Acting Vertical Type Ammonia Compressor (York Manufacturing Company). Sectional Elevation of Complete Machine.

a throttle valve which is common to both the cylinders. The pistons are of the common trunk pattern. This machine is typical of the inclosed compressor made by the Automatic Refrigerating Machine Co., Sydney, N.S.W., and San Francisco, and of a number of machines of this class made by various other makers.

The ammonia compressors constructed by the Tuxen and Hammerich's Engineering Works, Ltd., of Nakskov, Denmark, are mostly

of the horizontal double-acting type. Fig. 53 shows a belt-driven machine. The pump cylinder is fitted with a lining made from a special hard mixture of cast iron, so as to obviate the porosity which is inevitable when they are cast in one piece, and thus to prevent the absorption of ammonia by the metal. When worn, moreover, a liner, or bush, of this description can be removed, and replaced by a new one, the cylinder being thus renewed at much less cost in time and money than is the case when the cylinder is made of a single casting.

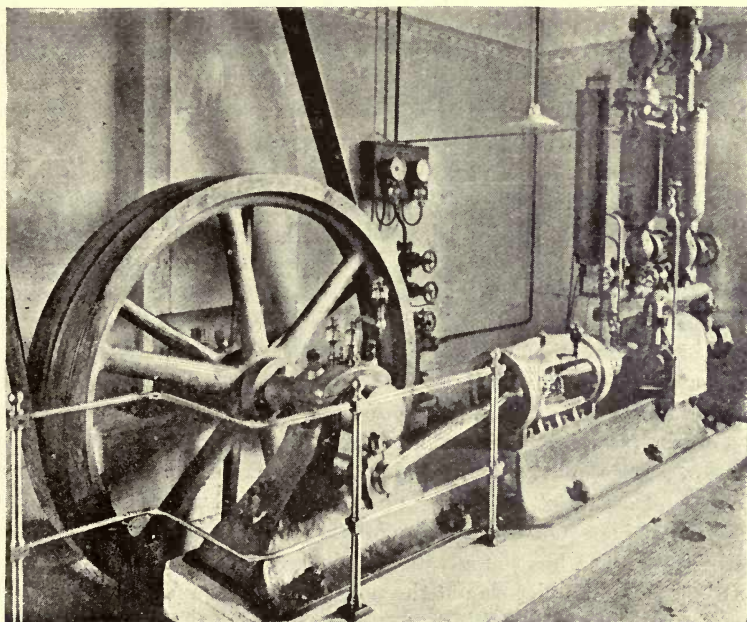

Fig. 53.—Horizontal Type of Belt-driven Tuxen and Hammerich Ammonia Compressor.

The valves are made of steel, and the valve boxes are arranged in such a manner that the valves can be withdrawn without necessitating the disconnection of any other portion of the machine or connections.

A gas-tight joint is formed at the piston or plunger rod stuffing box by means of an oil chamber formed between the packing rings, and by a patented arrangement the pressure of the gas in the compressor is employed to maintain a constant pressure of oil in this sealing chamber; in this manner, it will be seen, the tendency of the

ammonia itself to escape is utilised to prevent its escape. Another feature in this compressor is that the oil chamber is connected to the suction side of the compressor, so that in the event of the machine running hot it may be cooled by the simple expedient of running a current of cold air through the oil chamber. This arrangement is free from valves, and other working parts which are liable to fall into disrepair, and, moreover, requires practically no attention, and is claimed by the makers to admit of a pressure being kept up equal to the pressure of the ammonia, however much the latter may vary, a duty which it is impossible to perform by any arrangement of pump, and besides which the latter arrangement is, according to them, inferior in many other respects.

In a type of double-acting vertical ammonia compression machine constructed by the Buffalo Refrigerating Machine Co., of Buffalo, N. Y., U. S., the ammonia pump cylinder and the steam engine cylinder are in line vertically, and are bolted to a cast-iron framing mounted on a heavy bed-plate. Fig. 54 shows the ammonia compressor cylinder in vertical central section. The piston is fitted with self-adjusting packing rings, one at each end, and the pressure of the gas acts upon the conical surfaces of these rings so as to expand them outwardly equally in all directions, and so form a gas-tight joint. The pressure and suction valves are of large area, so that all wire-drawing of the gas is avoided; moreover, they are so arranged as to leave a minimum of spaces to retain gas, and they are formed with lengthy guide surfaces, and supplied with cushioning chambers, to prevent improper strains, and admit of their closing upon their seatings without noise and hammering. On the bottom of the suction valve stem a collar is provided, which has the advantage of preventing it from falling into the compressor cylinder should the nut on the upper end of the valve stem accidentally work off.

The valves are mounted in cages, which, it will be seen from the drawing, are so constructed that they can be readily removed from, or replaced in position, without necessitating the dismounting of any other part. A lengthy stuffing box is provided to prevent leakage of gas round the piston rod, and an oil chamber therein, between the upper and lower packings, is automatically supplied with oil from an oil tank. This oil tank is charged with oil, as necessary, by means of a hand pump connected to the tank. The lower part of the stuffing box oil chamber is connected with the lower part of the oil tank, and the upper part of the latter is connected with the suction valve of the compressor, as shown in the illustration (Fig. 54). The result of this

arrangement is that the oil in the oil tank is constantly under the suction pressure of the machine on both top and bottom ends of the cylinder. The oil tank being higher than the stuffing box oil chamber,

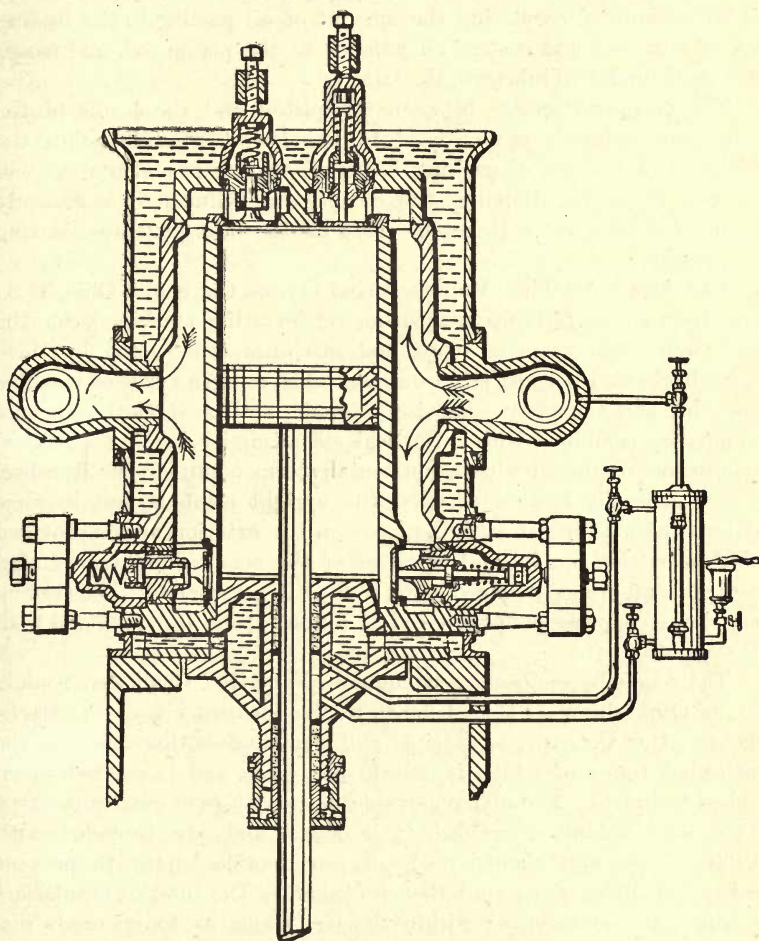

Fig. 54.—Vertical Type of Steam-driven Buffalo Ammonia Compressor.
Vertical Central Section through Cylinder.

the oil flows from the former to the latter by gravity, and should any leakage of ammonia occur through the first layers of packing into the stuffing box oil chamber, it will be drawn into the suction pipe of the

machine, and in this manner, according to the makers, provision is made to prevent the stuffing box pressure ever exceeding the working suction pressure of the condenser.

Suitable valves on the connecting pipes communicating with the oil tank admit of regulating the amount of oil passing to the stuffing box oil chamber, and enough oil adheres to the piston rod, and passes into the cylinder to lubricate the latter.

The clearance spaces between the piston and the heads of the compressor cylinder are reduced to the lowest possible point, the thickness of a sheet of packing being all that is provided. As will be seen from the drawing, the compressor cylinder is completely surrounded by a water jacket to carry off the heat generated during compression.

The Arctic Machine Manufacturing Co., of Cleveland, Ohio, U.S., have been successfully manufacturing refrigerating machinery for the past twenty-two years or more, and machines constructed by them as far back as 1879 are still running. The modern types of machine built by the Company comprise a double-acting vertical ammonia compressor, combined with a vertical steam engine, and two vertical compressors combined with a horizontal steam engine. The fly-wheel is now generally located between the upright columns, but in some patterns of machine it is still placed on the exterior, and is provided with an outside bearing. The valves of the compressor are mounted in cages, and are so arranged as to be readily get-at-able. The stuffing box of the compression piston rod is formed deep, and provided with oil sleeves.

The ammonia compression machine made by Geo. Challoner, Sons, & Co., of Oshkosh, Wis., U.S., belongs to the inclosed class. A pattern made by this Company is a triple cylinder single-acting machine, the entire box frame of which is cast in one piece, and is secured to an arched bed-plate. Circular removable flanges at each extremity carry extra long babbitted crankshaft bearings, and are provided with stuffing boxes and glands, made of considerable length to prevent leakage of oil or gas round the crankshaft. The interior crankshaft bearings are so mounted within the box frame as to be easily dismounted when desired. The working parts of the machine run in an oil bath in the hollow box frame, and lubrication is thus ensured without exterior aid. The upper part of the frame is faced and bored to receive the pump cylinders, which latter can be removed and replaced, if required, without disturbing the box frame.

In the larger patterns of machines the pump cylinders are provided

with safety heads. The suction valves are located in the pistons, and the discharge valves are either in the safety heads or in the false heads, and both suction and discharge valves are so arranged that they can be removed without necessitating the disconnection of the pipe connections. The connection to the suction is in the box frame beneath the cylinders, so that the frame is maintained cool by the low temperature gas returning to the pump cylinders. The discharge connections are formed to the pump cylinders above the safety heads, and both connections are fitted with stop-valves, and a by-pass is also provided, so as to admit of the pumps being reversed to pump the gas from the high to the low pressure side. A suitable purge valve on the discharge connection admits of the box frame being pumped out, and likewise the discharge of any air gaining admission to the interior on the opening of the frame.

A machine made by the Ideal Refrigerating and Manufacturing Co., of Chicago, is fitted with an arrangement for the more even distribution of the work of the compressor piston. To effect this the diameter of the crankpin circle is formed much larger than the piston stroke, and connection is made through a toggle lever arrangement. It is claimed that as the connecting rod to the crankshaft brings the two toggle levers connected to the piston rod into line, the force that is available for moving the piston will increase independently of the action of the toggle levers.

According to the makers the effect of the intermittent motion which the cam head on the piston imparts to the valve is to somewhat more than double the life of the latter, owing to the length of time during which motion is arrested whilst the crank is passing the dead centre, the toggle being then in a straight line with the piston rod. They, moreover, aver that it affords a considerable advantage, inasmuch as it gives the valve ample time to get properly seated, and for all the gas to be expelled from the cylinder, and not be sucked in again on the return stroke, thus greatly increasing the efficiency of the machine.

A vertical single-acting ammonia compressor (Stallman's) manufactured by the Creamery Package Manufacturing Co., of Chicago, Ill., U.S., consists of a pair of pumps, the lower portion of the cylinders being cored out so as to form a series of ports, which lead from the suction inlet round the piston and communicate with the cylinders at such times as the pistons are at the bottom or limit of their downward stroke. In this manner, the cylinders having been partly filled by the gas delivered through the suction valves in the pistons during their downward stroke, the charge will be fully completed at the termination

of the stroke, and the utmost pressure of evaporation be obtained in the cylinders owing to the passage of gas through the above-mentioned ports.

The discharge valve seat rests upon a shoulder formed by the enlargement of the upper part of the cylinder. This seat is made of tool steel, and is forced into position before the last or finishing cut is made, and is bored out with the cylinder, forming practically a portion of the walls of the latter. The outlet port, to which is connected the discharge pipe, is situated immediately above the valve seat, connected with the enlarged portion of the cylinder, and branching off from same at right angles. The discharge valve is of steel, and turned up from the solid. It has a disc-shaped bottom of larger diameter than the cylinder, and rests upon the above-mentioned seat in the annular enlargement in the cylinder; the upper part of the valve is cylindrical, and this trunk-shaped portion slides in the enlarged bore of the cylinder to form a guide.

When making its upward stroke the piston passes through the discharge valve seat, and comes into contact with the valve itself. The pressure on this valve is regulated by a spring having a screw adjustment through the cylinder head. This arrangement admits of the complete discharge of the gas from the cylinder, and at the same time forms a safety head, there being no clearance at all, and no loss of efficiency from the re-expansion of gas from such clearance. Another advantage claimed for this arrangement is that owing to the size of the valves a very slight movement only is required, whilst they give very large areas of openings, and allow of large volumes of gas passing rapidly.

The cylinders are so mounted upon the frames containing the crankshaft bearings and crosshead guides as to cause all the strains to fall upon the frames direct, instead of upon bearings in a separate bed-plate. The result of this form of construction is an absolute rigidity of alignment, and the frames are firmly secured in position by a massive bed-plate of box pattern. The two compressors can be provided with independent suction connections, and can then be worked independently in installations so operated that different conditions of temperature and varying back pressures exist, as, for instance, in cases where both ice-making and refrigerating are carried out together, or where freezing chambers are run along with ordinary cold stores.

Fig. 55 is a vertical section through the pump cylinder of a single-acting vertical ammonia compressor, designed by Mr C. A. MacDonald,

and made by the Hercules Ice-Making and Refrigerating Machinery Co., of Chicago, Ill., U.S.

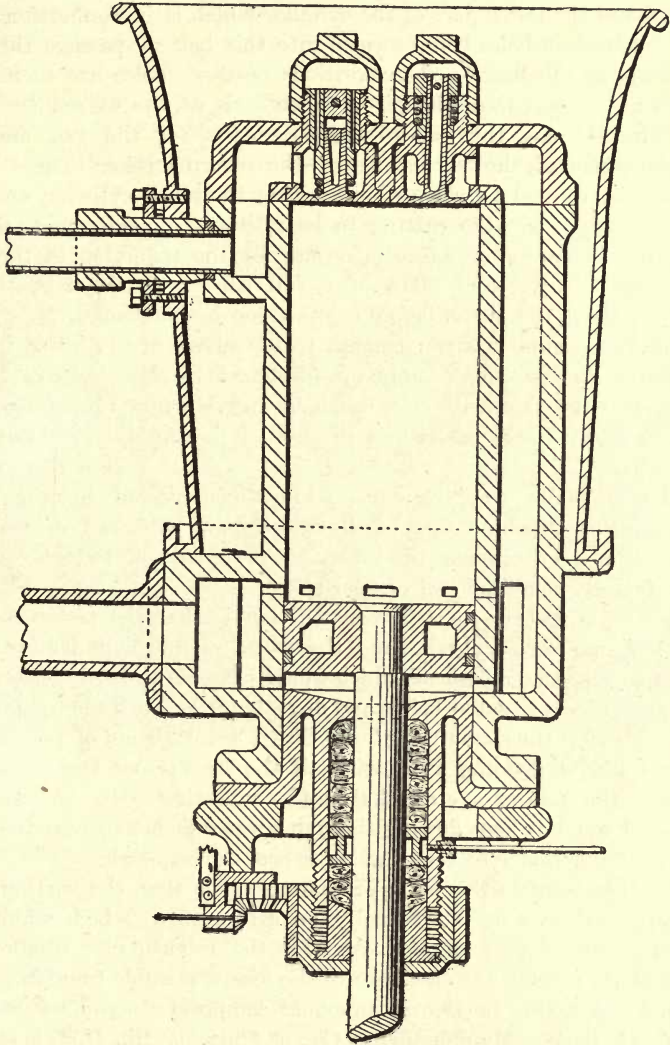

Fig. 55.—Vertical Type of Steam-driven Hercules Ammonia Compressor.
Vertical Central Section through Cylinder.

A special feature in this pump is that an arrangement is provided

for allowing free communication between the inlet branch and the interior of the cylinder when the piston is right down, or at the end of its travel in a downward direction. This consists of a belt or passage cast around the lower part of the cylinder which is in connection with the inlet branch, holes being formed into this belt or passage through the walls of the barrel. The positions of these holes are such that some will be lower than the piston when it is at the extremity of its downward stroke, thus affording free access for the gas, entirely independently of the valves, before the return stroke. These holes have to be formed by cores when casting the pump cylinder, and the arrangement causes the casting to be rather a difficult one to make. The holes, however, serve to compensate for the reduction in the size of the inlet valve, and allow of a full back pressure of gas being obtained above the piston before compression is commenced.

Somewhat similar arrangements to the above are provided in the Antarctic single-acting compressor (designed by Mr Norman Selfe, C.E.), made by the Antarctic Refrigerating Machine Co., of Sydney, N.S.W., and San Francisco, and in that of the Auldjo Machine Co., Australia.

The ammonia compression machines constructed by the Case Refrigerating Machine Co., of Buffalo, N.Y., U.S., are of massive build, and at the same time are so designed as to take up a comparatively small amount of floor space.

A special feature in their construction is that the piston rods of both the compressor cylinder and the steam engine cylinder are connected to the same crosshead which works between the cylinders. The steam cylinder is situated below and directly in line with the compressor pump cylinder, thus admitting of a direct transmission of power in a straight line, and doing away with all the strains and friction which occur in the case of a crankshaft and connecting rods. A constant stream of water is kept flowing through a water jacket surrounding the compression cylinder to keep the latter cool during work.

Another point in this make of compressor is that the suction and discharge valves work horizontally, an arrangement which admits of allowing only a very small pocket for the retention of compressed gas, and of reducing the clearance to the lowest possible fraction.

A double-acting horizontal ammonia compressor manufactured by the A. H. Barber Manufacturing Co., of Chicago, Ill., U.S., is shown in Fig. 56.

The machines of this Company are as a rule built with a box framing and a central crank in the case of belt-driven machines, and a Tangye

pattern frame and side crank when coupled directly to a steam engine. The cylinder is sunk into the frame, the cylinder flanges being set in the centre of and strongly bolted to the frame, thus equalising the pressure, so that the cylinder has no possible chance to move or rock; and a flat locomotive pattern guide is employed which admits of the frame of the machine being formed both deep and rigid, and rendering it practically impossible for the cylinder to get out of line.

The cylinder and valves are completely surrounded by water, thereby preventing the springs of the latter from becoming overheated and

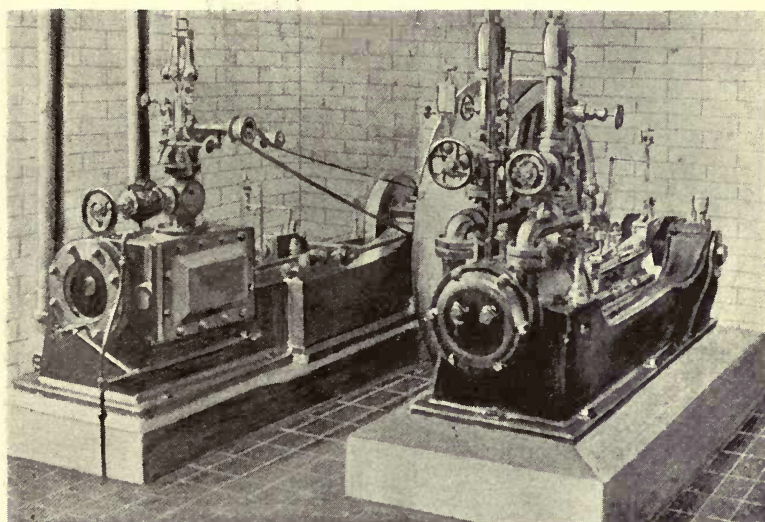

Fig. 56.—Double-Acting Horizontal Type Barber Steam-driven Ammonia Compressor.

losing their tension, and in this manner increasing their efficiency. The valves and their seatings are constructed of tool steel, and are hardened to render their life as long as possible. The valves, moreover, can be easily removed without having to disturb any other joints. The piston is light, fitted with metallic packing rings, and the piston rod stuffing box is rendered perfectly gas-tight by a double packing with a central oil chamber. The arrangement of the lubricator is such that it will oil the cylinder, valves, and piston rod. A strainer placed in the suction pipe or conduit near the compressor prevents any scale or other matter passing into the latter.

The smallest possible amount of clearance ($\frac{1}{64}$ in. at each end of the piston stroke) is left, and provision is made for the taking up of any slackness in the connecting rod through wear on the crank shaft or guide.

The valves, which are of a patented form of construction, cannot by any chance drop into the compressor cylinder, there being no nuts or keys to wear out and get loose. The compressor shown in Fig. 49 is one of 12-ton refrigerating capacity, and is connected directly with

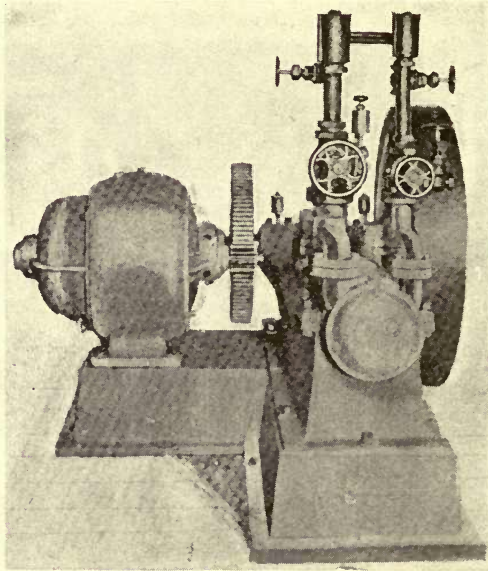

Fig. 57.—Double-Acting Horizontal Type Barber Electrically-driven Ammonia Compressor.

the driving shaft of a horizontal Corliss engine, with a heavy fly-wheel located between to answer for both. The floor space occupied by this machine (engine and compressor) is 8 ft. by 9 ft.

It is claimed by the makers that, owing to the extremely small amount of clearance in the pump cylinder, and the arrangement of the valves, it is possible for each stroke of the piston to compress the full area of gas contained in the cylinder.

In Fig. 57 is illustrated an 8-ton compressor supplied by the above company to do refrigerating work in the dairy building at the Trans-

Mississippi Exposition, at Omaha, Neb., U.S. This machine is connected by a shaft to an electric motor through a raw-hide pinion and cut gear, the motor and compressor being both mounted upon the same base or bed-plate. As this arrangement does away with all belts, hangers, or shafting, it occupies but little space, and it is always ready for work. The makers state that they can from experience thoroughly recommend the adoption of this pattern machine when electric power is to be used, having installed a number of different sized compressors

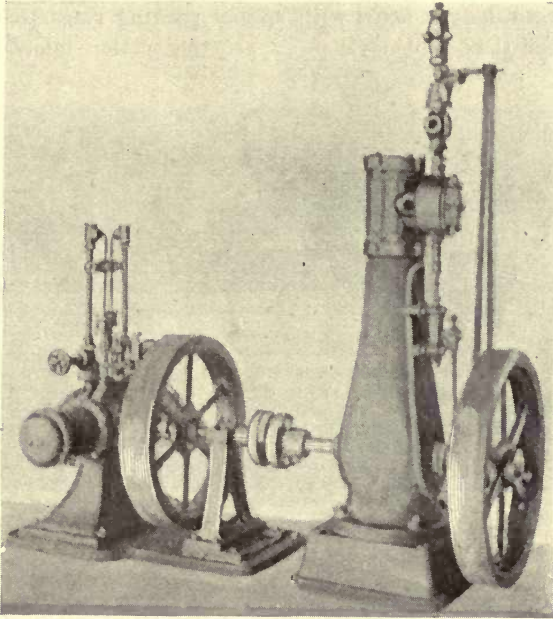

Fig. 58.—Small Single-Acting Horizontal Type Barber Steam-driven Ammonia Compressor.

with the electric motor connected up in this manner, which have been found in practical working to give great satisfaction, and to require but little attention.

Fig. 58 shows a very small single-acting ammonia compressor known as the "baby compressor," made by the same company. As will be seen from the illustration, this compressor is of the inclosed type, the piston and crankshaft running in an oil bath, and therefore working noiselessly and requiring little or no attention. The com-

pressor is coupled direct to a vertical engine, the power required to drive being under 3 H.P. The refrigerating capacity of this little machine is $1\frac{1}{2}$ tons, and it is adapted for use in creameries, meat markets, butchers' cold stores, hotels, &c., in fact in any place where only a small plant is needed.

Ammonia compression machines of several different patterns are built by the Vulcan Iron Works, San Francisco, California, U.S. Their horizontal, double-acting type of compressor has a strong girder frame. The compressor pump cylinder (Fig. 59) is furnished with a piston of extra length fitted with special packing rings that will take up any wear that may develop. A are the suction inlets, and B are

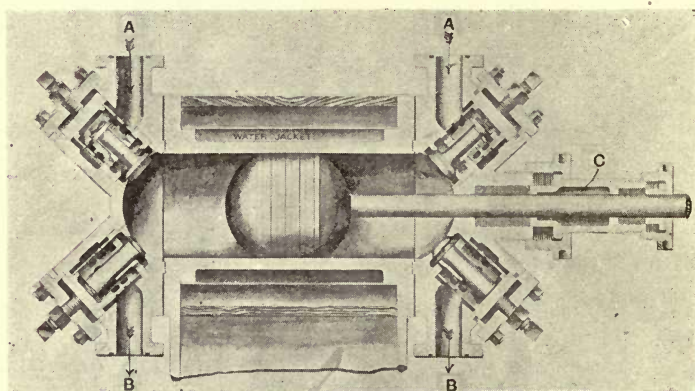

Fig. 59.—Double-Acting Horizontal Type Vulcan Ammonia Compressor.
Central Section through Cylinder.

the discharge outlets. The suction and discharge valves are of steel, simple in construction, of large area, easily removable for cleaning or inspection, and they are so made and arranged, being provided with a proper safety device (which will be seen from the sectional view, Fig. 59), that in case of accident, they cannot fall into the cylinder and wreck the machine. As will be seen from the illustration, moreover, the stuffing box of the piston rod is provided with an oil cellar or chamber *c* through which cold oil is constantly circulated by means of a pump attached to the top of the frame, this oil bath serving, as in other machines, the double purpose of acting as a seal to prevent the leakage of any ammonia, and of lubricating the piston rod. The cylinder of the ammonia compressor is water-jacketed, and neatly

lagged, a circulation of water being kept up through the jacket to remove the heat generated by the compression of the ammonia gas.

The compressor is provided with a dirt trap for catching and intercepting any foreign matter that may be brought back from the expansion piping, and preventing it from passing into the cylinder.

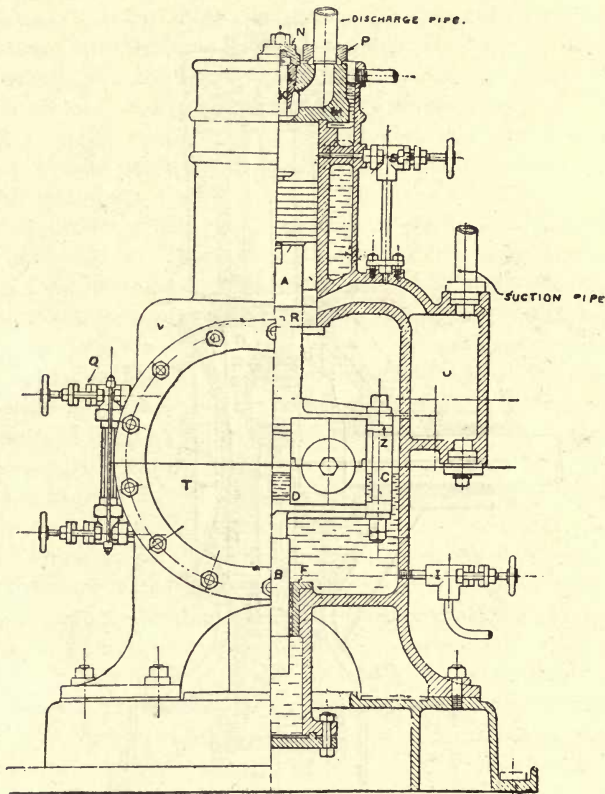

Fig. 60.—Small Single-Acting Vertical Inclosed Type Vulcan Ammonia Compressor. Elevation partly in Vertical Section.

Suitable cross connections are also provided for enabling the condenser to be pumped out for examination, repairs, &c. The crosshead and connecting rod, as well as the crankpin and the main bearing, are formed of extra strength and with large wearing surfaces, every provision being made for meeting any excess of regular duty.

The construction of the compressor will be readily understood from

the above description, and from an inspection of the sectional view, Fig. 59. They are built in sizes from 10 tons refrigerating capacity and upwards, and can be worked either on the dry or wet gas system. The compressors are constructed for belt driving, or are connected direct to a Corliss or Meyer cut-off steam engine.

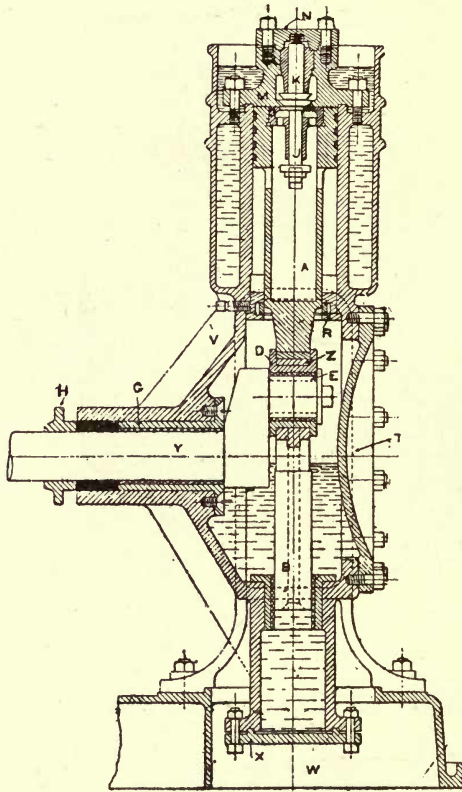

Fig. 61.—Small Single-Acting Vertical Inclosed Type Vulcan Ammonia Compressor. Transverse Section.

A small vertical single-acting compressor of the inclosed type, also made by the above firm, is shown in the sectional views, Figs. 60 and 61. The construction of the machine is as follows:—A is the piston yoke. B is the piston yoke guide. C are the yoke blocks. D is the crank box. E is the crank sleeve. F is the guide bushing. G

is the crankshaft bushing. *H* is the crankshaft stuffing box gland. *I* is the oil valve. *J* is the suction valve. *K* is the discharge valve. *L* is the discharge valve guide. *M* is the cylinder head. *N* is the discharge valve cap and tension spring. *O* is the suction valve seat. *P* is the pipe gland. *Q* are the gauge valves. *R* is the packing or dividing ring. *S* is the relief valve. *T* is the hollow box frame or casing cover. *U* is a dirt trap for intercepting any foreign matter and preventing access thereof to the pump cylinder. *V* is the body or frame of the compressor. *W* is the bed or base plate. *X* is the guide cover. *Y* is the crankshaft. And *Z* is the crank box wearing strip.

The cylinder opens, it will be seen, into the crank chamber, the sides of which constitute the supporting frame, thereby bringing the cylinder and shaft close together. The crank is forged on end of a heavy steel shaft which passes through a stuffing or packing box and gland in the side of the crank chamber, and the crankpin is of special construction, having a hardened steel sleeve held in place by a collar. The motion is transmitted to the piston through a strong yoke having a guide on its lower side. A movable cover or bonnet plate *T* admits of access being had to the crank chamber. The latter chamber is filled with oil to a level just above the packing box of crankshaft, the height of the oil in the chamber being indicated at any time by the gauge glass shown in Fig. 60, and this oil bath both acts as a lubricant to the moving parts of the machine in the crank chamber, and also as a seal for the packing box of the crankshaft.

The ammonia gas enters the crank chamber below the piston, the suction valve is provided with a safety cage and is situated in the centre of the piston, and the discharge valve is placed in the cylinder head, and both these valves are made of forged steel. A water jacket having a proper outlet surrounds the pump cylinder, and suitable facilities for cleaning are provided. The wearing parts being supplied with removable bushings tends to prolong the life of the machine at a small future expense.

This inclosed type of vertical single-acting compressor is made in sizes varying from $\frac{1}{8}$ ton up to $3\frac{1}{2}$ tons refrigerating capacity per twenty-four hours. Another pattern of this machine has two of these compressors mounted upon one base or bed-plate, and connected by a solid steel shaft with a crank on each end, and a single fly-wheel located centrally between the cylinders. The working parts of this compressor are identical with the above, and this type is made of from 5 to 10 tons refrigerating capacity per twenty-four hours. The small $\frac{1}{8}$ -ton machine requires only from $\frac{1}{4}$ to $\frac{1}{3}$ H.P. for driving purposes, and the floor space occupied is only 18 in. \times 30 in.

A compressor of the inclosed type with two cylinders in line horizontally is likewise made by Mr B. Lebrun, of Nimy, Belgium, in which any escape of ammonia past the pistons is received in a bell-shaped receptacle above the crank chamber, and after passing through a strainer is drawn in by the pumps on their suction strokes.

The St Clair compressor is one of the compound type, consisting of a combination of two or more single-acting compressors in such a manner that the gas is partly compressed at a lower pressure in one compressor, and then passed to another wherein the higher compression is applied. This machine has been greatly improved by Mr Thomas Shipley, and is manufactured by the York Manufacturing Co., of York, Pa., U.S.

A number of other types of ammonia compression machines will be found described in the chapter devoted especially to marine refrigeration.

CHAPTER VII

THE COMPRESSION PROCESS (*continued*)

Properties of Ether—Modern Ether Machines—Properties of Methyl Chloride—Methyl Chloride Machines—Properties of Sulphurous Acid—Sulphurous Acid Machines—Properties of Carbonic Acid—Carbonic Acid Machines.

PROPERTIES OF ETHER, AND ETHER MACHINES.

ETHER, $\left. \begin{matrix} \text{C}_2\text{H}_5 \\ \text{C}_2\text{H}_5 \end{matrix} \right\} \text{O}$, is a colourless liquid of great mobility, and possessed of a strong and peculiar ethereal smell. Ether is lighter than water, having a specific gravity 0.736, and it is not miscible with the latter liquid. The boiling point of ether is 34.5° , and its vapour is thirty-seven times heavier than hydrogen. Ether burns with a luminous flame, and explodes when it is mixed with air. The specific heat of liquid ether is 0.51.

The advantages and disadvantages of ether as an agent or medium have already been touched upon (pages 43 and 44), but they may be here recapitulated.

The great feature of ether is that it possesses the quality of working with a low pressure in the condenser, an advantage of considerable importance in very warm climates, as the efficiency of a low-pressure ether machine does not fall off appreciably, even when the condensing water attains to a comparatively high temperature. This is also advantageous by reason of the low condenser pressure—not exceeding from 7 to 10 lbs. per square inch, even in the hottest climates—being favourable to the maintenance of tight joints, and the consequent economy of the chemicals. This low working pressure and the great simplicity of all the working parts renders this class of machine, moreover, comparatively easy to manage.

On the other hand, the large size of the compressor required, about seventeen times that of an ammonia compressor of the same capacity, is objectionable, both by reason of first cost of the machine and the space occupied by it. Another serious objection is the highly inflammable nature of ether. Owing to its low boiling point great precautions

are necessary to avoid explosions when using this substance, by reason of the vapour becoming mixed with air.

All formula and rules intended for use with ammonia compressors are equally applicable to ether compressors, except, however, that it must be noted that the specific heat of the saturated vapour of ether is positive, and that consequently it will superheat during expansion, and will condense during compression. This quality renders it un-

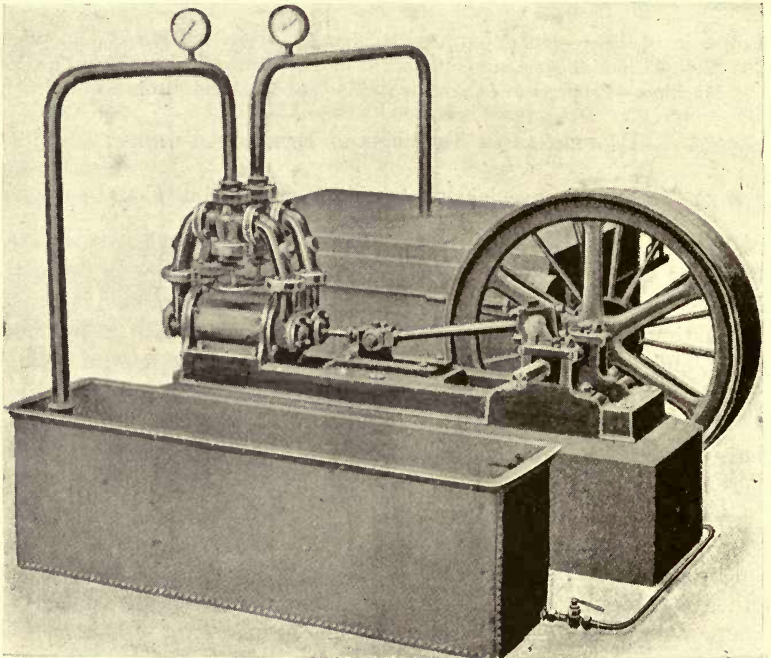

Fig. 62.—Belt-driven Horizontal Type West Ether Compression Machine.

necessary to make any provision against superheating, and an ether compressor is invariably worked with dry vapour.

The ether machines of Twining, Harrison, Tellier, Siebe Gorman & Co., and Della Beffa, have been already briefly alluded to on pages 37 to 42. In Fig. 62 is illustrated a modern standard type of ether machine constructed by H. J. West & Co., Ltd., London, which the company now supply for use in tropical countries. A commercially successful ether compression machine for the manufacture of ice

in large quantities was built by Mr Henry J. West, the founder of this firm, in the year 1859, and the manufacture of machines of this type has been continued successfully up to the present day. The machine shown in the illustration (which is intended to be belt-driven) is of the horizontal type, and is arranged with the condenser on one side, and an ice-making tank upon the other.

In the larger pattern of ether machines made by the firm, having a capacity of from 12 cwt. of ice daily and upwards, the ether compressor is placed on the same bed-plate as the steam engine, and is connected tandemwise to the engine piston rod. The motion work of these machines is of sufficiently massive construction, and all wearing surfaces are of ample proportions, each bearing, moreover, being provided with an automatic lubricator.

An ether compression machine not being called upon to withstand the same high pressures as a carbonic acid machine, or even an ammonia machine (the working pressure of an ether machine being only about 7 lbs. to 10 lbs. per square inch above that of the atmosphere), the same strength of construction is not demanded, and the design is very considerably simplified. The difficulty of making and maintaining tight joints is a comparatively easy matter, the pressure under which ether evaporates in the refrigerator being lower than that of the external atmosphere, but a very slight tendency exists towards leakage at the gland of an ether compressor. Any leakage, moreover, of air that may occur into the ether machine through faulty packing or joints, merely causes a slight accumulation of pressure in the condenser, which can be easily relieved by means of a valve provided for the purpose.

As ether possesses no affinity for the constituents of the atmosphere, there is consequently no danger of decomposition taking place, and the formation of acids or gases that may act injuriously on the interior surfaces of the machine, as is the case with sulphurous acid, which, under like conditions, decomposes and forms sulphuric acid.

A quality possessed by ether is that it is in a liquid state at the ordinary atmospheric pressure, and at the usual atmospheric temperatures, so that it can be drawn out of the plant at any time and stored in drums. This fact renders ether an especially suitable agent or medium for use in portable refrigerating and ice-making plants, consequently, machines working on the low-pressure ether anhydride process are those most usually chosen for military purposes, and such machines were successfully used by the British Government for military operations and field hospital work in the Abyssinian War in 1868, the

Ashantee Campaign in 1874, the military operations in Egypt in 1883, the Ashantee Campaign of 1895, the Soudan Campaign of 1896-97, and the last protracted and unfortunate war in South Africa.

PROPERTIES OF METHYL CHLORIDE, AND METHYL CHLORIDE MACHINES.

Another very low-pressure agent or medium is methyl chloride (CH_3Cl), which is obtained as a colourless gas which condenses at -20° Fahr. Methyl chloride is formed by acting upon methyl alcohol with hydrochloric or muriatic acid, or with phosphorus pentachloride, and is also obtained, together with other substances, by the action of chlorine upon marsh gas.

Machines operating with methyl chloride as an agent are manufactured by Messrs Douane, of Paris. As the pressure used with this agent does not exceed 10 lbs. per square inch above that of the atmosphere, the same remarks apply to methyl chloride compressors as to ether compressors, and the construction is practically identical. The condenser and evaporator tubes of the methyl chloride machines made by Messrs Douane are all covered with electro-deposited copper.

In Fig. 63 is illustrated in vertical central section a compression machine, designed by Mr M. E. Douane. In this machine the cooler or refrigerator is shown on the left-hand side of the drawing. There is a hollow standard surmounted by a single-acting cylinder, the top of which has valves for suction and discharge. The space above the discharge valve communicates with a coil leading by a tube to the stop-cock serving for the admission of the refrigerating liquid in the cooler. The chamber underneath the suction valve communicates by a pipe with the outlet of vapour from the cooler. A gauge screwed upon a nozzle shows the pressure in the cooler. The piston of the compressor is worked by a rod and crankshaft which passes through a stuffing box in the side of the hollow standard.

PROPERTIES OF SULPHUROUS ACID, AND SULPHUROUS ACID MACHINES.

Sulphurous acid or sulphur dioxide (SO_2) is a gas obtained by the burning of sulphur, as has been already mentioned on page 44. Sulphurous acid has a molecular weight of 65, and a density of 32. The specific heat of liquid sulphurous acid is $\cdot 41$ (water = 1). The critical pressure is 79 atmospheres, and the critical temperature 312° Fahr. The specific gravity of the gaseous acid is 2.211 (air = 1), and the specific gravity of the liquid at a temperature of -4° Fahr. is 1.491.

Andreef gives the following formula for expressing the relation of the specific gravity s of the liquid to the temperature t :—

$$s = 1.4333 - 0.00277t - 0.000000271t^2.$$

Sulphurous acid or sulphur dioxide possesses the advantage of being liquefiable at a comparatively low temperature, and machines adapted to use this agent or medium, whilst not operating at anything like as low a pressure as ether or methyl chloride machines, still work at a very much lower one than ammonia machines, with condensing water

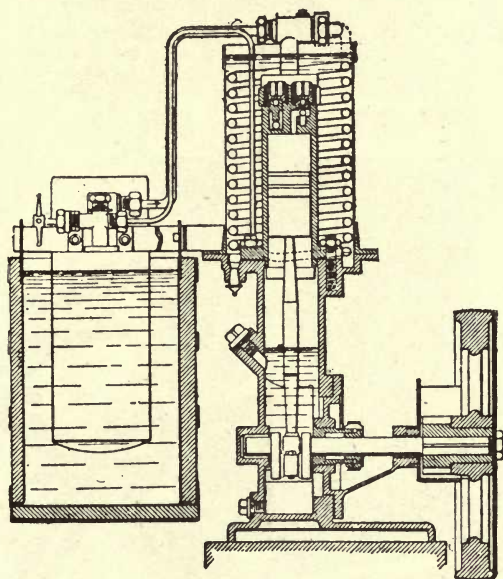

Fig. 63.—Single-Acting Inclosed Type Douane Methyl Chloride Compressor.
Vertical Central Section.

at normal temperature, the pressure being only from about 36.75 to 44 lbs. per square inch. Sulphur dioxide possesses certain lubricating qualities, consequently compressors using this agent require no extra lubrication.

Sulphur dioxide is liable to form sulphuric acid on exposure to the air, and cause corrosion—iron being the metal chiefly acted upon, and gun-metal or copper being tolerably immune against attack. Consequently it is necessary to take great precautions against the presence of any leaky joints in the apparatus.

This comparatively low working pressure, and consequent correspondingly low temperature of compression, admits of machines using

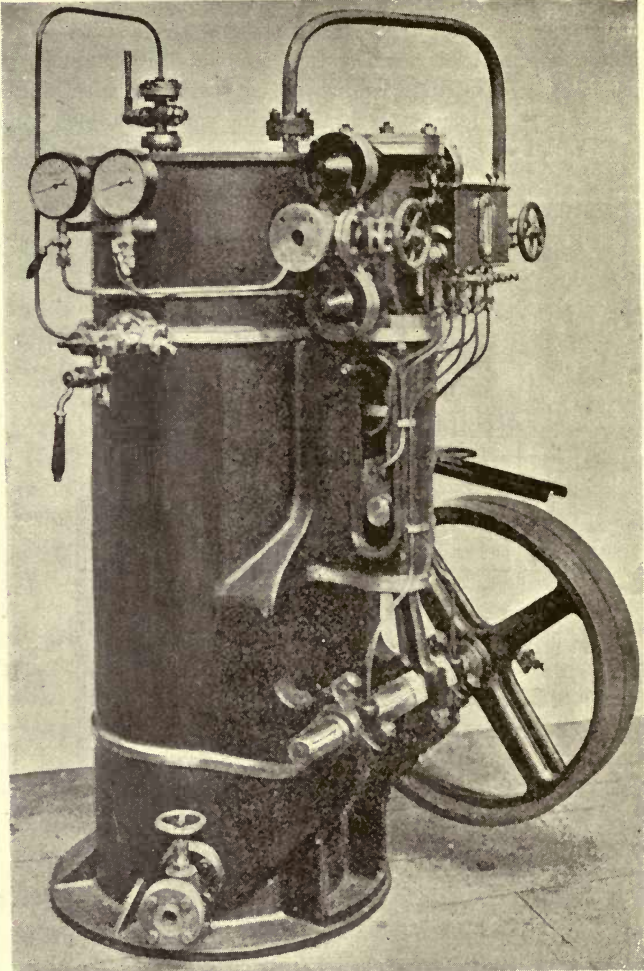

Fig. 64.—Belt-driven Double-Acting Vertical Type Quiri Sulphurous Acid Compression Machine.

this agent working without superheating, and with dry vapour. This latter is not practicable in the case of machines working with either

ammonia or carbonic acid, in both of which superheating is impossible—especially so in the case of carbonic acid—on account of the overheating of the piston and stuffing box that would occur, and consequently all these latter machines work more or less on the wet system, and a small portion of the work of evaporation, which ought to take place in the refrigerator exclusively, has to be effected in the compressor.

A number of different patterns of machines adapted to work with sulphur dioxide are made by Quiri & Co., Schiltigheim, Alsace. The smallest type of machine made by this firm, which is shown in Fig.

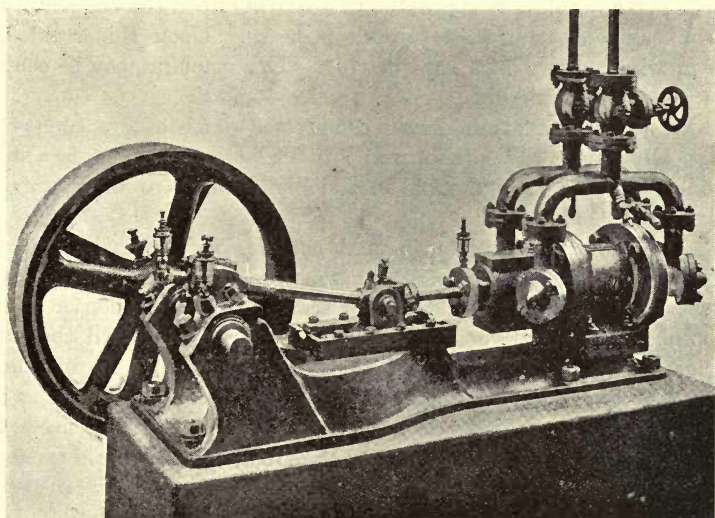

Fig. 65.—Belt-driven Double-Acting Horizontal Type Quiri Sulphurous Acid Compressor.

64, has a vertical compressor, the cylinder being bolted to the lower head which is formed in one piece with the guides, the latter, as well as the crankshaft journals, being cast together with the condenser. The compressor is of the double-acting type, and is provided with valves of phosphor bronze, with steel spindles. These machines are made in sizes of from $4\frac{3}{4}$ cwt. to 12 cwt. ice-making capacity per twenty-four hours.

The larger sizes of machines are of the double-acting horizontal pattern, and are arranged either for belt or rope drive, or are direct coupled to a steam engine.

The belt-driven compressors consist either of a single cylinder double-acting pump, such as that shown in Fig. 65, which is of remarkably simple construction, or of two practically similar pumps, laterally coupled, that is to say, arranged side by side, and having a single crankshaft with two end cranks, and a central fly-wheel between the two compressors adapted for a rope drive.

In another arrangement, intended for rope driving, two similar compressors are mounted in line upon the ends of a single bed plate. Both the piston rods of the compressor cylinders are in this case coupled through their connecting rods to the same crankpin upon a crank at the end of a crankshaft supported in a bearing upon the bed-plate, and in an outside bearing in a suitable pedestal. Upon this crankshaft is a fly-wheel, grooved for rope driving. This machine may be coupled to a Sulzer steam engine.

One pattern of steam-driven compressor consists of a compressor practically similar to that shown in Fig. 58, laterally coupled to a steam engine with slide valve motion, in a similar manner to the two pumps above mentioned.

These anhydrous sulphuric acid compressors are each connected with a condenser, either of the submerged or immersion type, or, in cases where condensing water is scarce, with a condenser of the atmospheric evaporative type, and with a refrigerator, and the entire refrigerating apparatus consists of these parts solely, no oil-pumps, oil-separators, rectifying apparatus, or other accessories, such as are required with ammonia and carbonic acid machines, being necessary. This fact obviously enables anhydrous sulphuric acid machines to be very much simplified in construction, and renders their successful working a far easier matter to accomplish, as the manipulation of the above apparatus is troublesome, and to an unskilled attendant presents many serious difficulties. This system is one, therefore, which should most undoubtedly be advantageous for small machines intended for use in hotels, creameries, dairies, and in private houses, and by butchers, fishmongers, &c., and in other places where the machine is left to the care of a comparatively unskilled person.

A very small and remarkably compact belt-driven anhydrous sulphur dioxide or sulphurous acid machine, designed and patented by Messrs Douglas & Conroy, and manufactured by W. Douglas & Sons, Ltd., Putney, London, S.W., is shown in Figs. 66 to 69. Instead of the compressor being mounted vertically upon the side of the condenser, as it is in the small machine previously described, it is, it will be seen, placed horizontally upon the top of the condenser, and is of the

inclosed type, consisting of two single-acting horizontal cylinders, arranged in line, the pistons being operated by a crank working in a box. The arrangement will be readily understood from the general view of the apparatus shown in Fig. 66, upon which for convenience the various parts are marked, and from the various other views, Fig. 67

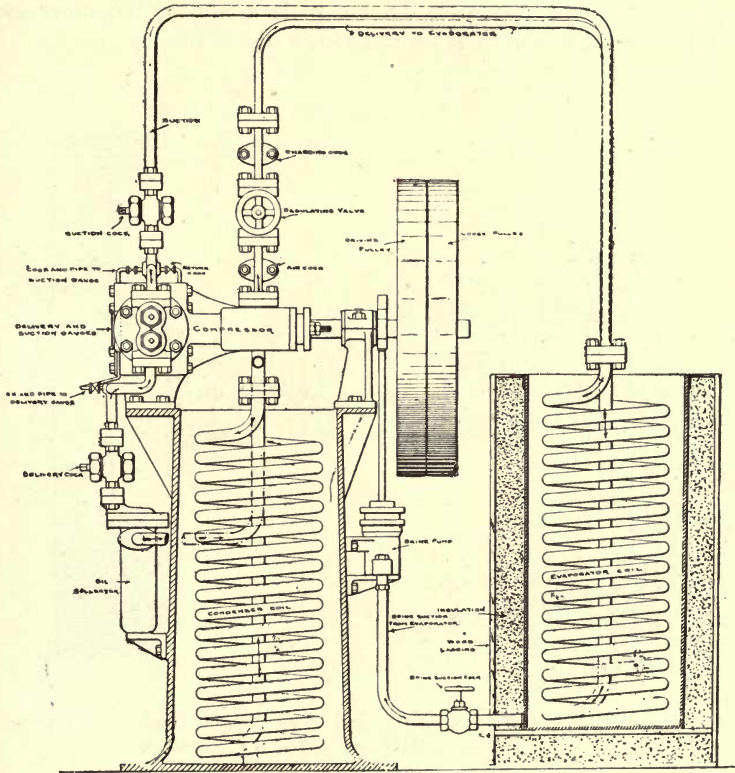

Fig. 66.—Belt-driven Horizontal Inclosed Type Douglas-Conroy Sulphurous Acid Compression Machine. Elevation partly in Vertical Section.

being a plan of the compressor, Fig. 68 a vertical section on the line A-B, Fig. 67, and Fig. 69 being a vertical section on the line C-D, Fig. 67.

The compressor is of the single-acting duplex inclosed type, and consists of two cylinders arranged in the same line axially, united by a central casing forming the crank chamber, and mounted on a bracket

on one side of the upper part of the condenser. The sides of the chamber are closed by gas-tight covers in one of which is provided a stuffing box and gland through which passes the crankshaft. The outer portion of the crankshaft is supported in a bearing in a pedestal carried upon another bracket provided upon the opposite side of the upper part of the condenser, and this shaft has mounted upon its outer end the fast and loose driving pulleys, and on the inner end, within the central crank box or chamber, a disc crank.

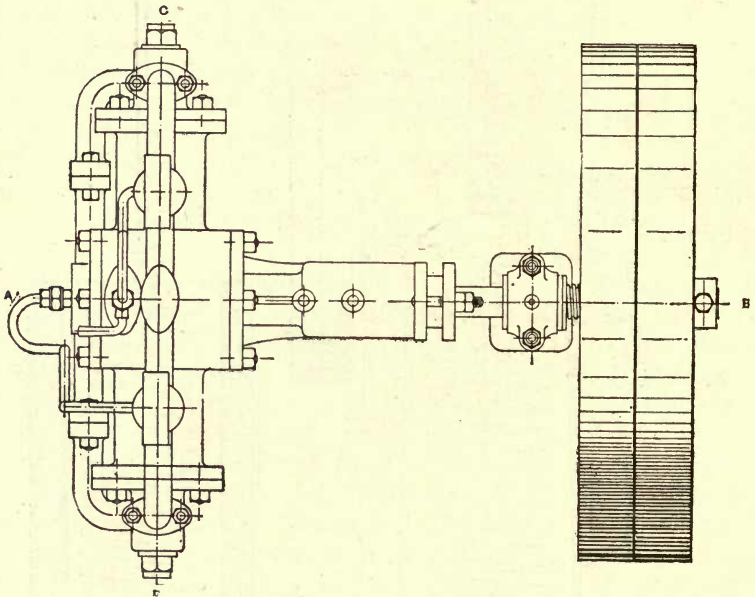

Fig. 67.—Belt-driven Horizontal Inclosed Type Douglas-Conroy Sulphurous Acid Compression Machine. Plan of Compressor.

The two pistons working in the pump cylinders are rigidly fastened together by means of a rectangular frame or plate secured between them by bolts. The result of this arrangement is that the pistons act as a continuous guide, being entirely free from lateral thrusts, and the usual guides are thus dispensed with, thereby considerably simplifying the construction. The pin of the crank disc works in a slot provided in the central rectangular frame or plate connecting the pistons. This admits of a pause at the end of each stroke, which is

advantageous inasmuch as it gives the valves time to reseal themselves properly before the commencement of the return stroke.

Four valves are provided, two at each extremity of the duplex-pump cylinders, viz., one for compression and the other for suction, and each pair of similar valves is united into one pipe by means of a

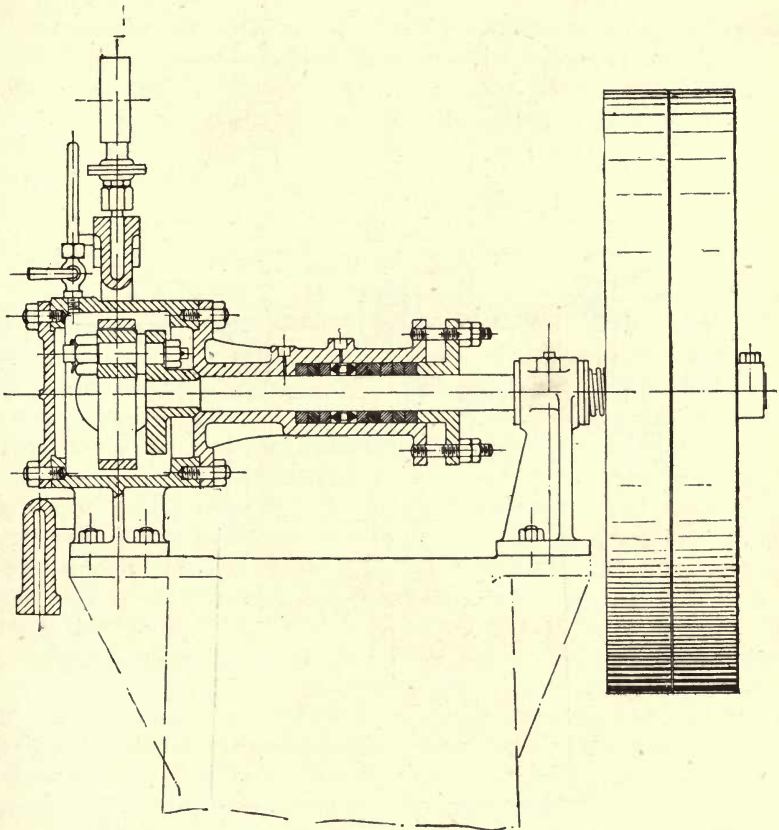

Fig. 68.—Belt-driven Horizontal Inclosed Type Douglas-Conroy Sulphurous Acid Compression Machine. Section on line A-B, Fig. 67.

tee connecting piece. The central crank box or chamber is kept partially full of oil, so that the working parts are immersed in an oil bath and have the most perfect lubrication.

The condenser consists of a cast-iron tank and serves as a pedestal to support the compressor. In this tank is placed a coil of wrought-

iron pipe tested to a pressure of 500 lbs. per square inch, and welded into one piece without joints, in which coil the sulphurous acid gas is liquefied by the pressure from the compressor aided by the cold water circulating in the tank.

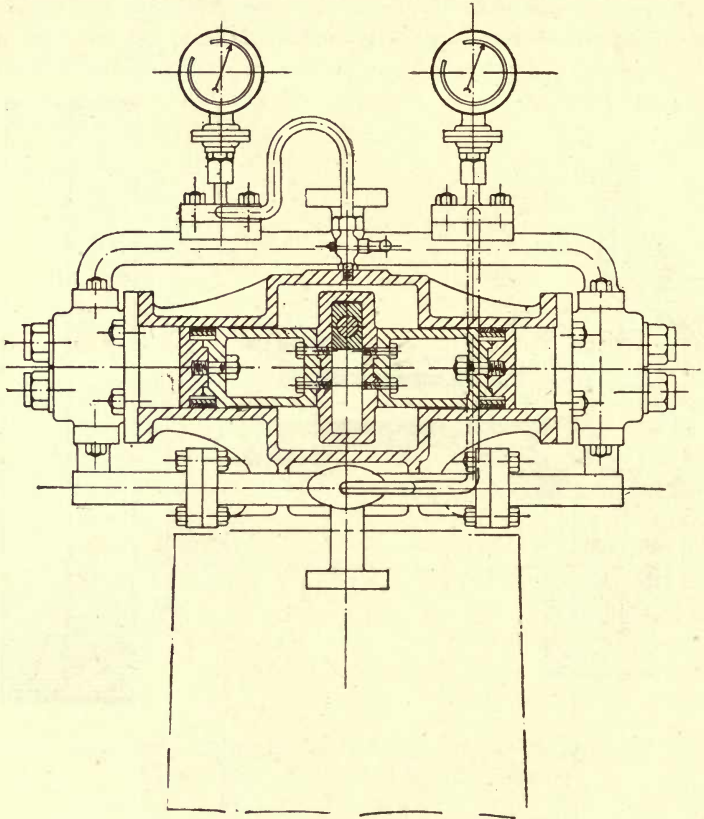

Fig. 69.—Belt-driven Horizontal Inclosed Type Douglas-Conroy Sulphurous Acid Compression Machine. Section on line C-D, Fig. 67.

The evaporator or refrigerator consists of a suitable tank having a coil submerged in brine, and when the machine is used in connection with a cold room or store this evaporator tank is formed of galvanised iron and of rectangular shape, and is placed directly in the room or store to be cooled.

Fig. 70 shows a horizontal type of belt-driven Humboldt sulphurous acid or sulphur dioxide compression machine. A feature of this machine is that the cylinder is jacketed, no cooling of the piston rod being provided. The general design of the machine, which is made by the British Humboldt Engineering Co., Ltd., London, will be seen from the illustration.

Amongst other firms manufacturing sulphurous anhydride compression machines mention may be made of the following:—A. Borsig, Tegel, bei Berlin, Germany; The Raoul Pictet Company, of Paris; Delion & Lepen of Pré St Gervais, Paris; the Société Genevoise de Construction, of Geneva; and Thomas Ths. Sabroe & Co., Ltd., Aarhus, Denmark.

PROPERTIES OF CARBONIC ACID, AND CARBONIC ACID MACHINES.

Carbon dioxide, or, as it is commonly called, carbonic acid (CO_2), has a molecular weight of 44, and a density of 22. Carbon dioxide is invariably formed when carbon is burned in an excess of air or oxygen. The best method of preparation is by acting upon marble, chalk, or other form of calcium carbonate with hydrochloric or muriatic acid. Carbon dioxide occurs free in air, and in the water of some mineral springs, the quantity of the gas present in air being about 4 volumes per 10,000 volumes of air. As carbon dioxide is evolved in respiration and by the burning of coal-gas, &c., it is always present in larger quantities in dwelling-houses than in the open air. Carbon dioxide gas is also given off during the process of fermentation, and is found in the bottom of old wells, &c.

The advantages to be gained by the use of this agent or medium are: non-inflammability, high specific gravity, thus rendering its heat of vaporisation for a given volume much higher than that of ammonia; and non-corrosive action on copper, which latter quality is of special advantage in marine refrigerating installations. The objections to its use have been already gone into in a previous chapter.

A simple and at the same time effective way to test the purity of liquefied carbonic acid is to solidify it, in which condition the slightest impurity can be instantly detected by smelling. A ready method of effecting this solidification is given by the Carbonic Acid Gas Company, London, as follows:—"Place the tube on a box or chair in a horizontal position, tightly fasten a small linen or canvas bag (4 to 6 in. square) over the nozzle of the tube, and open the valve fully. The acid will then stream out with full force, become solid inside the

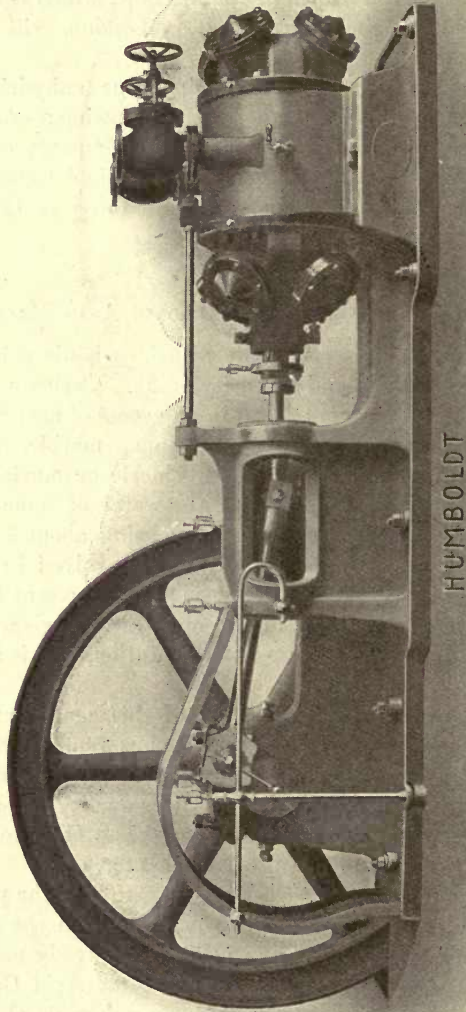

Fig. 70.—Vertical Type of Belt-driven Humboldt Sulphurous Acid Compression Machine.

bag, and remain in that state for hours, evaporating only very slowly, and showing a temperature of about 200° Fahr. below freezing point."

Carbon dioxide machines have already been dealt with on pages 45 to 47, where brief descriptions of the original machines of Wind-

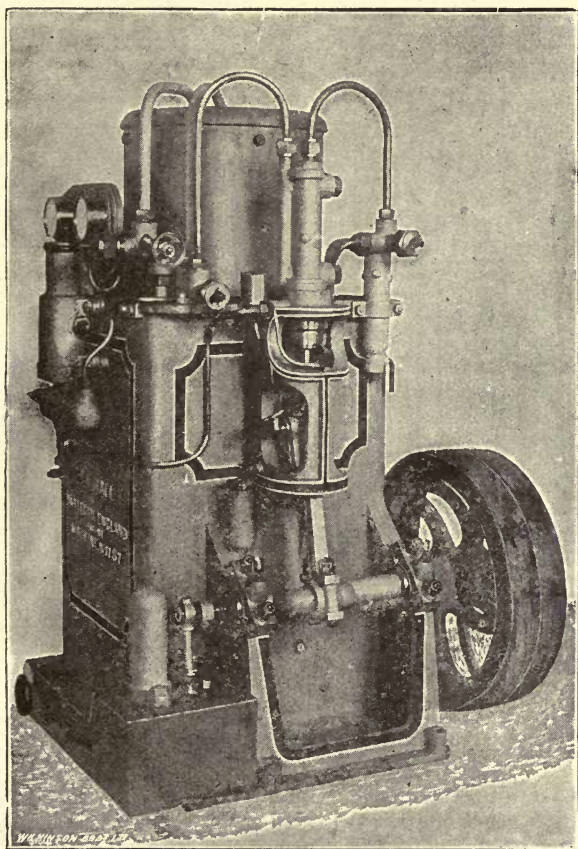

Fig. 71.—Belt-driven Vertical Type Hall Carbonic Acid Compression Machine.

hausen and Lowe will be found. As will be found there mentioned the Windhausen machine has been greatly improved by J. & E. Hall, Ltd., of Dartford, Kent, the proprietors of the original patents, who have been largely instrumental in introducing this system all over the world.

Figs. 71 to 77 illustrate a small, exceedingly compact and well-designed belt-driven carbonic anhydride machine made by the above firm. The design of this machine is, it will be seen, both simple and compact, and as the use of this agent admits of a very small size of compressor being employed relatively to the work performed, the

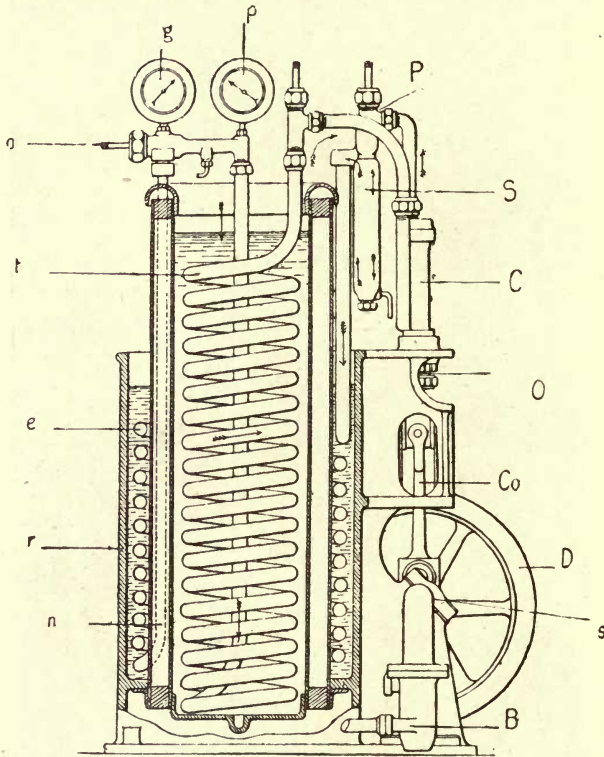
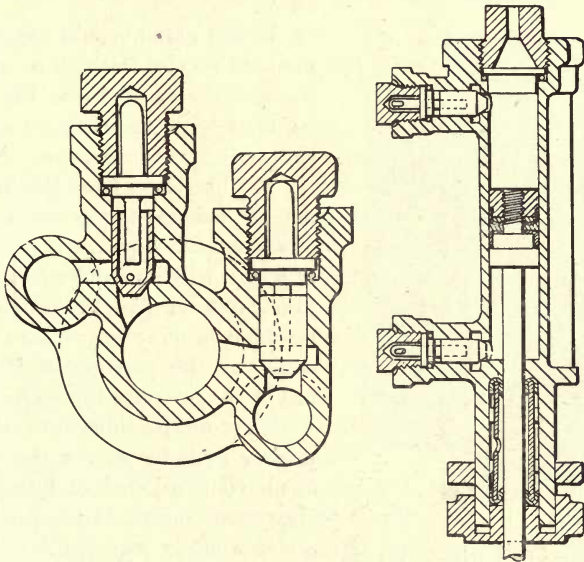

Fig. 72.—Belt-driven Vertical Type Hall Carbonic Acid Compression Machine. Sectional View.

whole machine occupies but little space. The general arrangement of the machine will be readily understood from the sectional view, Fig. 72, in which *c* is the compressor vertically mounted, as shown, on the side of the condenser tank or casing *r*, the latter being fitted with coil *e*. *n* is the evaporator casing fitted with an evaporator coil *t*, and arranged inside the condenser *r*, so that its lower part is surrounded by the latter,

the condenser coils *e* occupying the annular clearance or space round the evaporator, and the evaporator casing *n* forming an insulated division between the condenser casing *r* and the evaporator coils *t*. *o* is the regulating or expansion valve or cock, and *g* and *p* are respectively the condenser and evaporator gauges. *s* is the separator, P is a patent safety valve, *o* is a patent hollow oil gland for preventing leakage taking place round the compressor piston rod. *co* is the connecting rod, *s* is the crankshaft, *D* the driving pulley, and *B* the brine circulating pump.



Figs. 73 and 74.—Belt-driven Vertical Type Hall Carbonic Acid Compression Machine. Cross Section and Vertical Central Section through Cylinder.

It will be seen that the machine consists essentially of a circular or rectangular cast-iron tank *r* carrying the compressor *c*, inside which tank are the condenser coils *e*, and inside these again is a double tank *n*, with insulation between and the evaporating coils *t* in the centre.

The compressor cylinder *c*, which is shown in vertical longitudinal section in Fig. 74, and in transverse or cross section looking on back end in Fig. 73, is cast in a special hard bronze for these small-sized machines, by which means the two essentials of soundness and hardness are ensured, and the suction and delivery valves are identical for facilities of interchange. The compressor piston rod gland *o* is kept

gas-tight by means of two cupped leathers on the compressor rod, as clearly shown in Fig. 74. A special oil is forced into the space between these two cup leathers at a pressure above the greatest pressure liable to occur in the compressor, so that whatever leakage takes place at the gland is a leakage of this special oil, either into the compressor cylinder, or out into the atmosphere, and there can be no leakage of the gas. What slight leakage of the special oil takes place into the compressor cylinder is advantageous, inasmuch as it serves both to lubricate the compressor and to fill up all clearances.

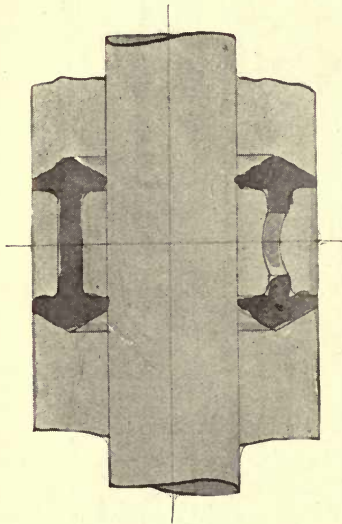

Fig. 75. — Belt-driven Vertical Type Hall Carbonic Acid Compression Machine. Vertical Section through Spiral Packing Ring.

condenser coils, all the gas is delivered into the separators wherein it is made to impinge against the sides of the vessel, and the oil adhering to the latter drains to the bottom, and is drawn off from time to time as occasion may require, whilst the compressed gas passes off by an opening at the top on its way to the condenser. In the suction passage is fitted a suitable copper strainer as shown in Fig. 76.

The condenser consists of coils *e*, of wrought-iron hydraulic pipe, usually of $\frac{1\frac{3}{8}}$ in. bore, which in the submerged or immersed type employed in the present example are placed in the tank *r*, and

If the gland should require packing, and no cup leathers be available, the special ring shown in Fig. 67 may be used with ordinary packing (see chapter on "Management," &c.).

The loss of oil from the lubricator due to leakages is replaced by means of a small hand pump, a few strokes of which will be required to be made every four or five hours whilst the machine is at work, as may be indicated by the position of the piston rod of the pressure lubricator.

The oil passing into the compressor cylinder serves the purpose, as above mentioned, of filling up the clearance spaces, and any surplus above what is required for this purpose will be discharged with the gas through the delivery valves. In order to prevent the oil discharged with the gas from passing into the

surrounded with water. The coils are electrically welded together into such lengths as to avoid the presence of any joints inside the tank.

The evaporator or refrigerator consists of an insulated tank *n*, containing nests of coils *t*, also formed of long lengths of electrically

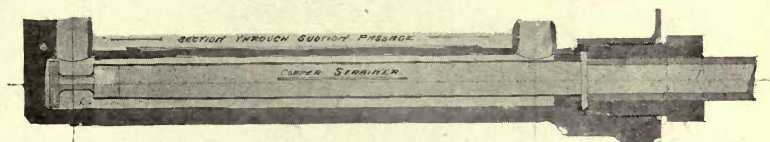

Fig. 76.—Belt-driven Vertical Type Hall Carbonic Acid Compression Machine. Vertical Central Section through Suction Passage.

welded wrought-iron hydraulic pipes within which the carbonic anhydride evaporates. The heat required for evaporation is obtained from the brine surrounding the pipes. A regulating or expansion valve *o* placed between the condenser coils *e* and the evaporator coils *t* admits of the quantity of liquid carbonic anhydride passing from the condenser being suitably regulated.

To enable the compressor *c* to be opened up for examination of the valves and piston without loss of carbonic anhydride, stop-valves are fitted on the suction and delivery sides, by means of which the carbonic anhydride can be confined to the condenser and evaporator.

As the machine might be again started, after being thus shut down, without the delivery valve being opened, which would lead to an excessive pressure in the delivery pipe, owing to there being no outlet from the latter, and probably result in the fracture of this pipe, a safety valve *p* is provided. This safety valve, which is shown in vertical central section, drawn to an enlarged scale, in Fig. 77, consists, it will be seen, of an ordinary spring safety valve, at the base of which is a thin copper disc *A*, which is designed to relieve any excessive pressure, considerably below that to which the machines are tested. The disc is made perfectly gas-tight, an object which it would not be possible to obtain by means of the spring safety valve alone, and this latter only comes into action upon the rupture of the copper disc *A*.

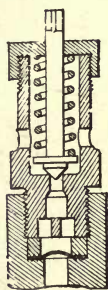

Fig. 77.—Belt-driven Vertical Type Hall Carbonic Acid Compression Machine. Vertical Central Section through Safety Valve.

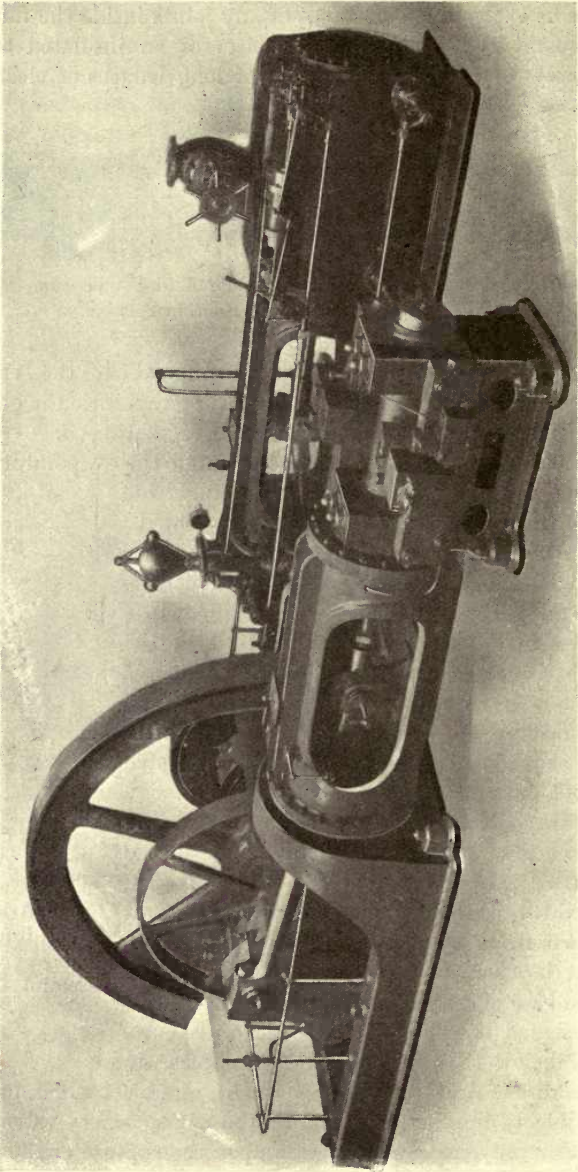

Fig. 78.—Horizontal Type of Hall Carbonic Acid Steam-driven Compressor. Side by Side Pattern

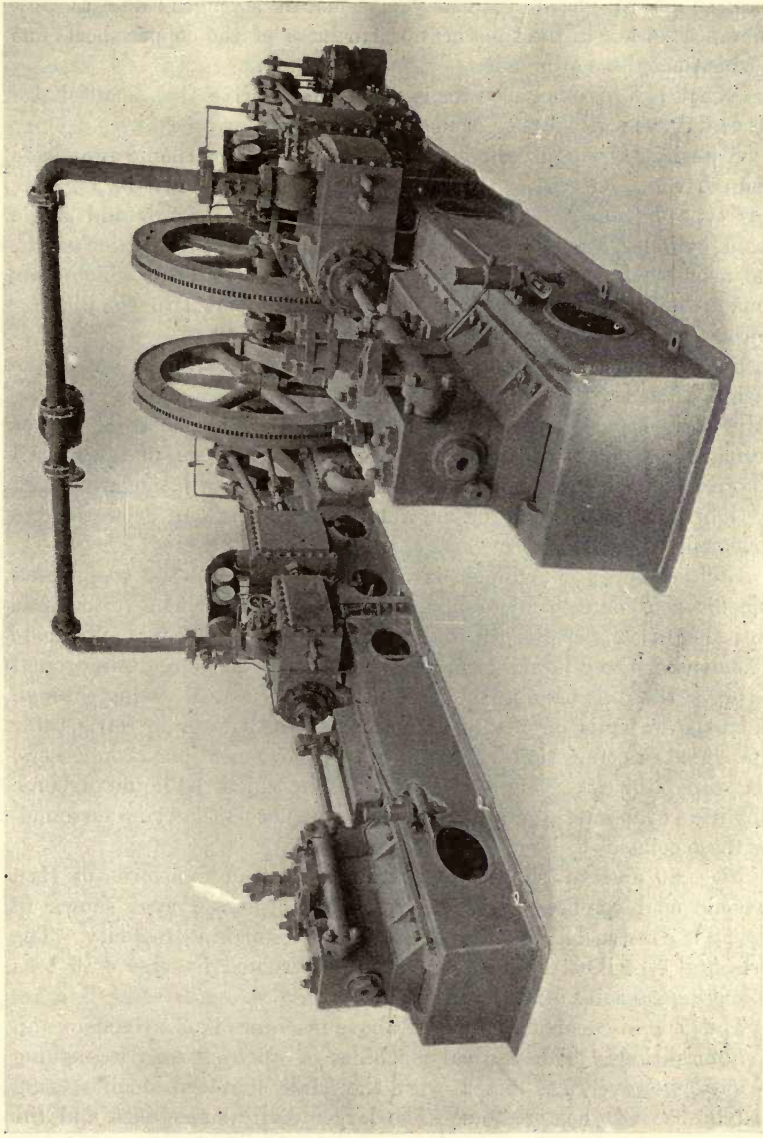

Fig. 79.—Horizontal Type of Duplex Steam-driven Hall Carbonic Acid Compressor.

Great care has necessarily to be exercised in making these copper discs, so as to guard against variations in strength, due to any differences either in the thickness or hardness of the copper sheets out of which the discs are made.

About $1\frac{1}{2}$ brake horse-power is required to drive this smallest size self-contained vertical type of machine.

A horizontal single-cylinder double-acting Hall carbonic anhydride steam-driven compressor, side by side pattern, is shown in Fig. 78. This type of compressor is arranged with the compressor and single steam cylinder side by side, both connected up to the same shaft. The machine is especially made for ice-making plants in which clear ice is made from distilled water. The machine shown in the illustration has a capacity of 60 tons of ice per day.

Fig. 79 illustrates a horizontal duplex Hall carbonic anhydride machine, fitted with compound steam cylinders arranged side by side, and with a surface or jet steam condenser located in the front part of the machine. The two compressors are, it will be seen, driven by tail rods from the steam cylinders, and the cranks of the latter are placed at right angles to each other, thereby ensuring an even turning movement.

Each compressor cylinder is arranged to deliver the compressed carbonic acid or carbonic anhydride into an independent condenser consisting of coils of pipe, in which the compressed carbonic anhydride is condensed into a liquid form by the cooling water circulating round the pipes, the coils of pipes being contained in a steel casing through which the water is circulated. A separate evaporator or refrigerator is provided in connection with each of the above-mentioned condensers, this evaporator consisting of coils of pipes, in which the liquid carbonic anhydride evaporates, and during this process cools the brine surrounding these coils.

Figs. 80 and 81 show two of the most recent patterns of Hall carbonic acid compressors. The vertical belt-driven type shown in Fig. 80 is constructed in sizes of 1 to 5 tons ice-making capacity. The horizontal type illustrated in Fig. 81 is constructed in sizes of 6 tons ice-making capacity and upwards.

The general construction of the above machines is clearly shown in the illustrations. The vertical machines of up to 2 tons ice-making capacity, however, are fitted with the Hall standard double-acting hard bronze CO_2 compressors. The larger vertical machines and the whole of the horizontal machines are provided with double-acting CO_2 compressors, each cut from a solid ingot of special high carbon steel,

and all sizes are provided with patent oil sealed glands and pressure lubricators. The compressor pistons are fitted with hydraulic leathers and the glands on the standard machines each contain two hydraulic leathers, the gland being kept tight by the oil from the pressure lubricator. In special cases, or for tropical work, however, the machines are frequently fitted with the Hall patent metallic gland

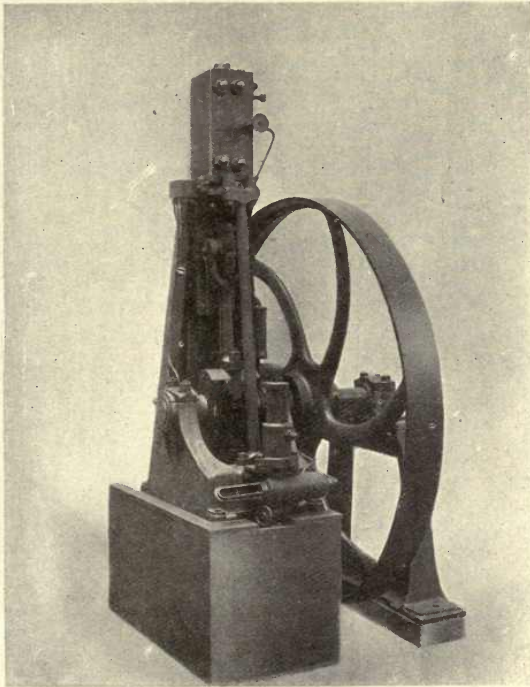

Fig. 80.—Vertical Type of Belt-driven Hall Carbonic Acid Compressor.
Most Recent Pattern.

packing, still retaining the pressure lubricator, and with metallic piston rings.

The compressor suction and delivery valves are made interchangeable, and each are provided with separate and interchangeable valve seats. The valves and seats are made of special hard steel, and are so arranged that they can readily be withdrawn or replaced without disturbing any of the connections. As shown in the illustrations

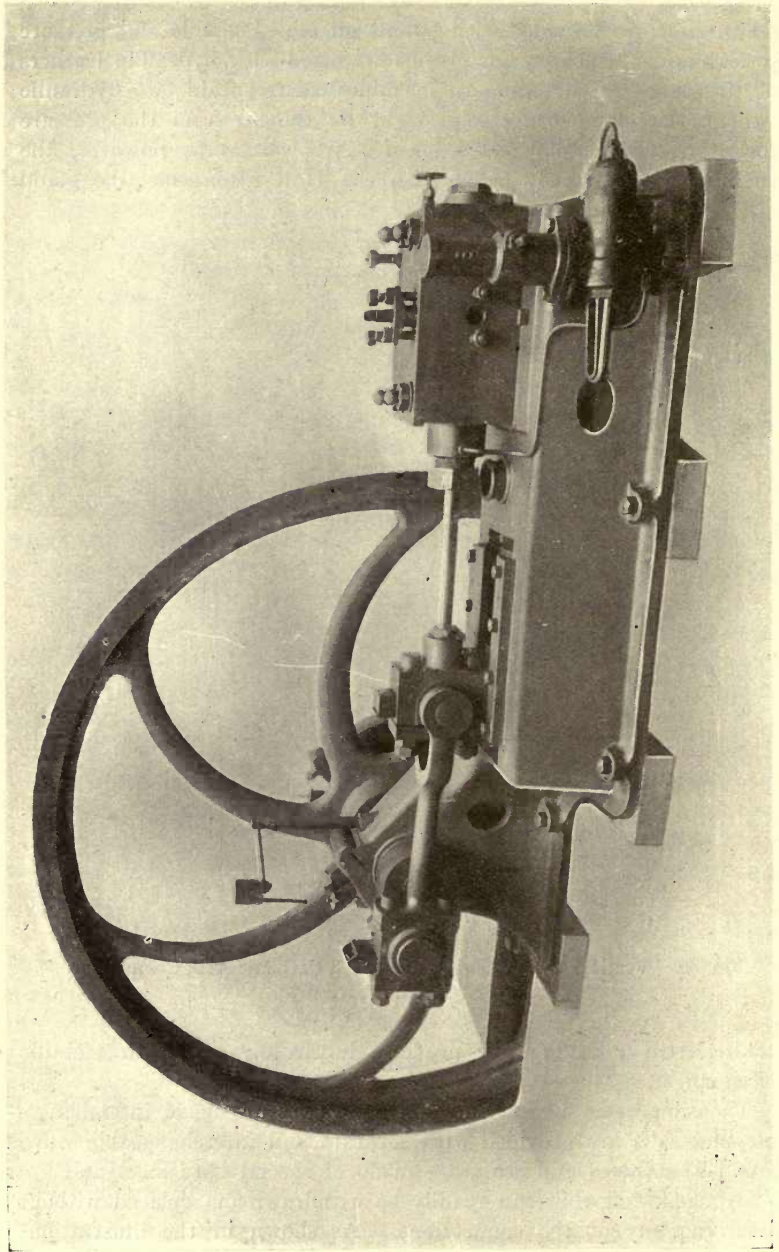

Fig. 81.—Horizontal Type of Belt-driven Hall Carbonic Acid Compressor. Most Recent Pattern.

both vertical and horizontal machines have the open type flat slipper guide, which gives much greater accessibility. All bearing surfaces

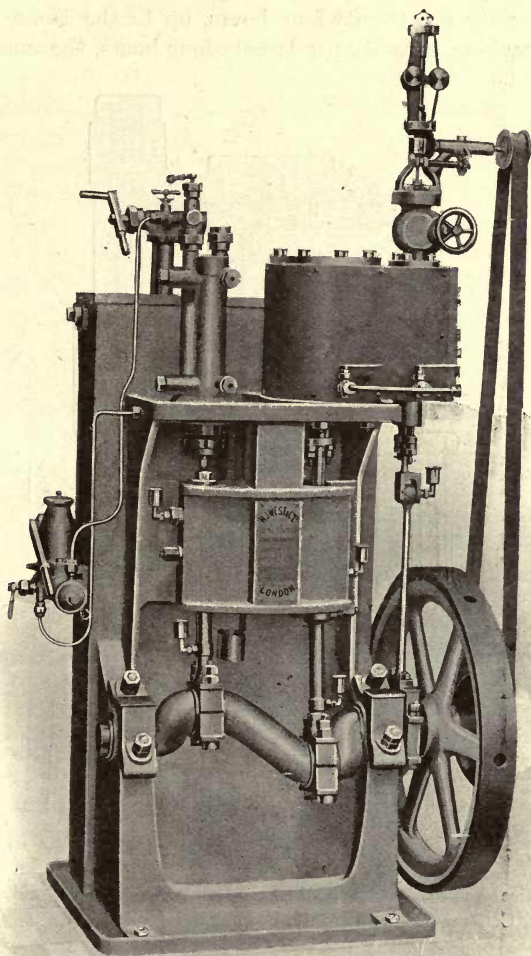

Fig. 82.—Vertical Type of Steam-driven West Carbonic Acid Compression Machine.

are of ample size to ensure satisfactory and continuous working over long periods.

Fig. 82 illustrates a steam-driven vertical carbonic anhydride machine, built by H. J. West & Co., Ltd., London. This type of machine is made in various sizes, from No. 1 machine of 3 cwt. ice-making capacity per twenty-four hours, up to the No. 8 machine of 2 tons ice-making capacity per twenty-four hours, the smaller sizes

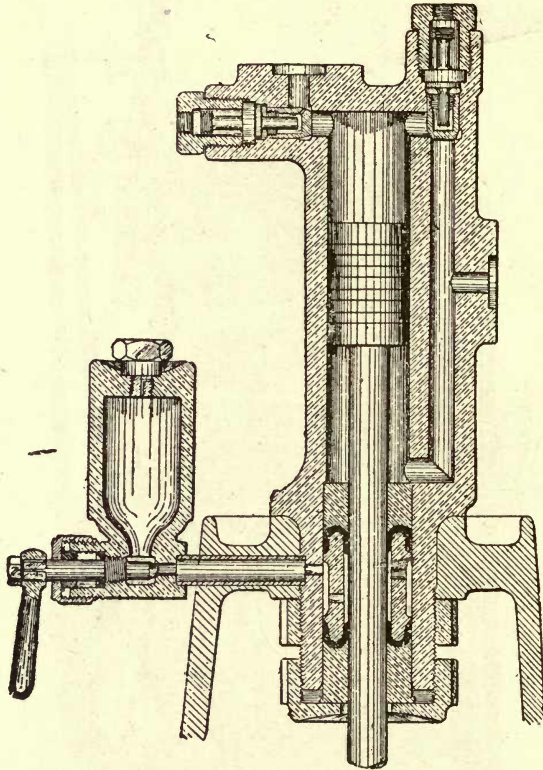

Fig. 83.—Vertical Type West Carbonic Acid Compression Machine. Vertical Central Section through Compressor Cylinder.

being belt-driven. The amount of condensing water at 55° Fahr. required for the smaller size is 48 gals. per hour, and that for the larger 400 gals. per hour.

The arrangement of this type of vertical compressor is very neat and compact. A rigid girder-shaped vertical cast-iron frame carries the compressor and motion work, and the perfect alignment of the piston rod

and crosshead is secured by boring the pump seat and guide channel in one operation. The condenser, which is of the submerged type, is placed behind the compressor, and is coupled directly to it by an extension of the wrought-iron coil without any intermediate pipes or joints.

These small machines have compressor cylinders cast from a special bronze alloy, combining the requisite strength and soundness, and finishing to a perfectly hard, smooth surface for the piston rings to work on.

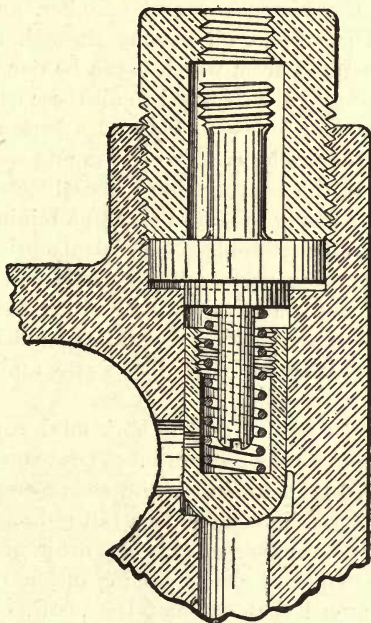

Fig. 84.—Vertical Type West Carbonic Acid Compression Machine. Vertical Central Section through Valve. Enlarged Scale.

The construction of the compressor will be readily understood from the vertical central section shown in Fig. 83. The suction and delivery valves are made exactly alike, and of the same size for the purpose of interchangeability, so that one spare valve will replace either. The valve, which is shown in central section, drawn to a greatly enlarged scale in Fig. 84, is made of tempered steel, and beats upon a hard phosphor bronze seat, forming a perfectly gas-tight joint when closed. Another point is that the weight of the valve is reduced to a minimum, and the lift is under one-eighth of an inch, so that it has no tendency

to hammer itself to pieces. The method of forming a gas-tight joint round the piston rod is shown in Fig. 83 and is, it will be seen, practically similar to that employed in Messrs Hall's carbonic acid compressor. Two capped hydraulic ram leathers are placed face to face upon the rod about 3 in. apart, the space between them being filled with oil, which is fed in from the small lubricator shown on the left-hand side of the illustration. The oil bath which surrounds the rod both effectively stops all leakage of gas, and, at the same time, serves to lubricate the piston rod and cylinder, and to fill up the clearance spaces. The surplus oil passing through the compressor is trapped in an oil separator, from which it can be removed as desired.

A dead weight safety valve is fitted to all these compressors, except the very smallest size, and is set to blow off a little above the highest working pressure of the machine. The design and construction of this little machine is good, the bearings have liberal wearing surfaces, and are adjustable, thus reducing wear and tear to a minimum, and tending to prevent any noise when running. Special attention is paid to the lubrication of the working parts, every bearing and working surface is provided with an automatic lubricator, which feeds just sufficient oil to maintain the surfaces in proper working condition, and no more, thus preventing or greatly reducing dirt, waste, and the tendency to hot bearings.

A standard pattern of belt-driven horizontal carbonic anhydride compressor is also made by the same firm. The steam-driven horizontal compressor is arranged tandemwise to the steam engine cylinder, and the compressor piston rod is coupled to a tail rod on the steam piston. Steam-driven horizontal compressors are also made of the duplex type, coupled direct to compound or triple expansion condensing steam engines, and so arranged that one-half the plant, consisting of compressor, condenser, and evaporator, may be disconnected for overhauling or repairs, whilst the other half continues in operation.

Machines of 6 tons ice-making capacity and over are fitted with compressors bored out of a solid steel forging, by which both soundness and strength of material is secured, and furthermore, a hard, smooth, glassy surface for the piston rings and cup leathers to work upon.

Kroeschell Brothers Ice-Making Co., of Chicago, Ill., U.S., manufacture carbonic anhydride machines of both vertical and horizontal patterns, the former being that used for the smaller sizes of machines, and the latter for the larger ones.

Fig. 85 shows a front view of a small vertical belt-driven machine of $\frac{1}{4}$ ton ice-making capacity per twenty-four hours, and requiring

1 H.P. for driving purposes. This type of machine is made in seven different sizes, the smallest being the above, and the largest having an ice-making capacity of 3 tons per twenty-four hours, and requiring 12 H.P. Two vertical single-acting compressors are located inside the cast-iron condenser tank, which latter is mounted upon a frame

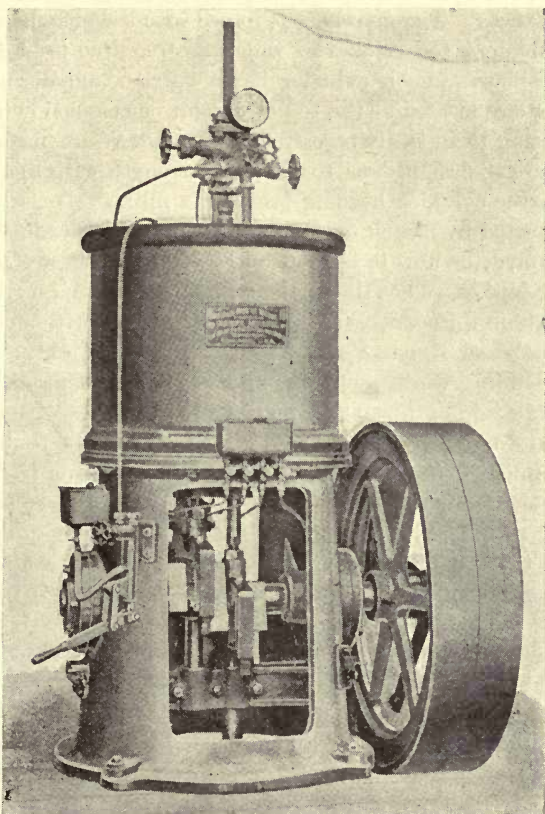

Fig. 85.—Vertical Type Belt-driven Kroeschell Carbonic Acid Compression Machine.

consisting of a box casting carrying the crankshaft and guides. The compressor cylinders are made of semi-steel, which secures the two essentials of soundness and hardness, and the piston rods are provided with a patent stuffing box sealed with glycerine. This device consists of cupped leathers on the compressor rod, into the spaces or chambers

between which glycerine is forced at a pressure superior to the suction pressure in the compressor, so that any leakage at the stuffing box is a leakage of glycerine, either into the compressor cylinder or out into the atmosphere, and not a leakage of gas.

Obviously the leakage of glycerine into the compressor cylinder is an advantage, as it both serves to lubricate the piston and also to fill up all clearances. The glycerine is forced into the chambers by means of a hand pump, a few strokes of which are required to be made every four or five hours. Each cylinder has a suction and discharge valve, all of which are located at the top of a joint or common cylinder head, thus rendering them easily accessible. The valves are made of forged steel, and are so designed as to combine strength with lightness. On one side of the cylinder head is provided a filling valve, which can be easily connected by means of a short pipe with the ordinary drum of carbonic anhydride now in common use. Stop-valves are provided in the suction pipe as well as the condenser coil, so that the suction and discharge valves in the condenser coil can be examined without loss of gas.

The condenser consists of a spiral coil made of extra strong iron pipe, surrounding the compressor, and is connected at one end with the discharge side of the latter, and at the other end with a combined separator and liquid receiver, placed at the back of the frame.

The crankshaft bearings are formed in the cast-iron frame supporting the condenser tank, and the double-throw crankshaft actuates the compressor pistons by means of strong yokes, having guides at the lower side, thus enabling the long connections, such as connecting rods and crossheads, which would be otherwise necessary, to be dispensed with. The double-throw crankshaft is made of forged steel, and is extended or overhanging at one side of the frame, so as to receive the fast and loose driving pulleys.

The receiver consists of a strong wrought-iron cylinder, with a stop-valve located at the top, and a blow-off cock at the bottom, the latter admitting of the glycerine carried over from the cylinder being drawn off. A gauge mounted upon a three-way valve, by means of which it can be caused to communicate either with the compressing or with the suction side of the machine, is provided on the top of the condenser tank.

On the opposite side of the machine to the driving pulleys is provided, as will be seen in the drawing, a small hand pump, by the operation of which the cylinders can be lubricated. A safety valve is also provided to guard against possible accident through neglect or ignorance on the part of the attendant.

The larger sizes of vertical combined compressors and condensers are identical in design with the exception that they are fitted with connecting rods and crossheads instead of yokes, and these crossheads and connecting rods, as also the main bearings and the double-throw crankshaft, are all of extra strength, and have large wearing surfaces, and every provision is made in them, as in the smaller machine, for meeting any excess of regular duty. All the machines are fitted with an automatic lubricating device. The machines are also built direct coupled with a vertical steam engine, or geared to an electric motor.

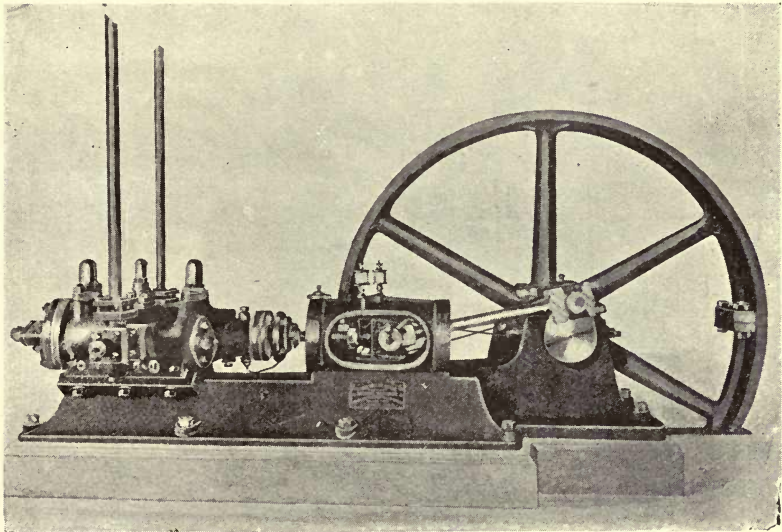

Fig. 86.—Horizontal Type Belt-driven Kroeschell Carbonic Acid Compression Machine.

The larger sizes of carbonic anhydride machines constructed by the firm are, as before intimated, of the horizontal pattern, and their standard sizes run from 2 tons ice-making capacity per twenty-four hours up to 50 tons ice-making capacity per twenty-four hours, requiring respectively 8 H.P., and 120 H.P. for driving purposes.

Fig. 86 shows a standard pattern of belt-driven Kroeschell horizontal double-acting compressor. The compressor cylinder is provided with a jacket through which the return gas passes, which arrangement it is claimed both imparts greater strength to the cylinder, and also

keeps it perfectly cool. The piston rods, connecting rods, cranks, pins, and valves are made of forged steel, and the latter are made identical for facilities of interchange.

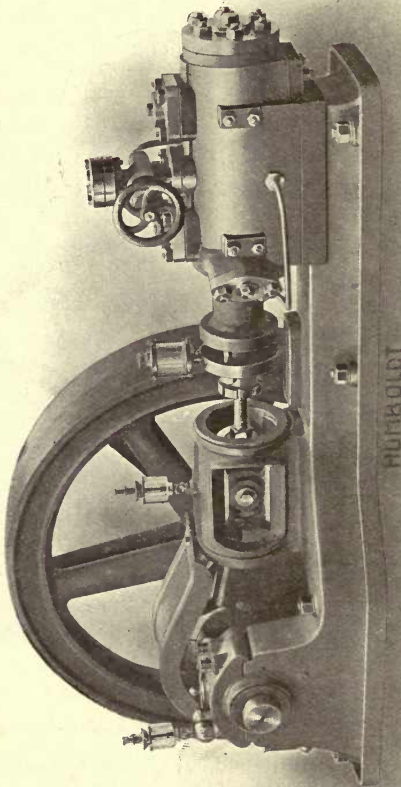

Fig. 87.—Vertical Type of Belt-driven Humboldt Carbonic Acid Compressor.

Leakage round the compressor piston rod is prevented by an arrangement similar to that used on the small vertical type of machine, but instead of the hand pump, a belt-driven pump operating con-

tinuously is provided for replacing the glycerine which leaks out of the stuffing box.

Any glycerine which passes into the compressor beyond what is necessary to fill the clearance spaces is discharged with the gas through the delivery valves. This glycerine is prevented from going into the system by a separator in which the glycerine drains to the bottom, and can be drawn off from time to time. As glycerine has no affinity for carbonic acid, and consequently undergoes no change in the machine, there is no chance of the condenser coils becoming clogged.

The condenser consists of coils of wrought-iron extra heavy pipes so welded as to avoid any joints in the tank, and arranged either on the submerged or on the atmospheric or evaporative principle. The evaporator also consists of similar coils of pipes, a regulating or expansion valve being provided between it and the condenser. The safety valve consists of a housing at the base of which is a thin disc, calculated to blow off at a pressure considerably below that to which the machines are tested. The joints have all special flange unions and brass bushings, and are made absolutely gas-tight with packing rings of vulcanised fibre which, whilst withstanding heat, have also sufficient elasticity to ensure the tightness of the joint when either hot or cold.

The firm also make belt or rope driven horizontal double-acting double compressors arranged tandem-wise or in line, and driven from a crank on a central crankshaft. These machines are suitable for large installations.

Fig. 87 illustrates a horizontal type of belt-driven Humboldt carbonic acid compression machine. A feature in this machine is the facility with which the parts can be got at for inspection or repairs. The pressure valve is fitted with a safety device which is connected with the suction channel.

Fig. 88 shows a large duplex carbonic anhydride compressor built by the Haslam Foundry and Engineering Co., Ltd.

A carbonic acid machine made by the Cochran Company, Lorain, Ohio, United States, is of the belt-driven vertical pattern, and the compressor cylinder is mounted upon a box-shaped or hollow bed-plate on which is placed the condenser, thus forming a very compact and neat arrangement, and lending itself to transport.

A later design of machine by this company has the hollow or box pattern bed-plate extended, and is driven by a motor mounted upon the latter.

A compact and well-designed horizontal type of carbonic acid compressor is made by the Atlas Co., Ltd., Copenhagen, which firm

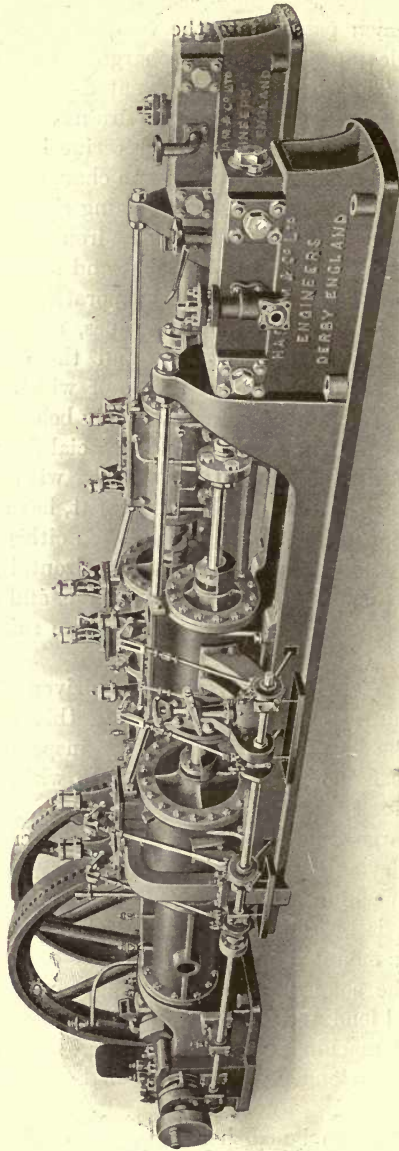

Fig. 88.—Large Duplex Horizontal Type of Haslam Carbonic Acid Compressor.

manufacture the refrigerating machinery under the Schou patents, originally made by the Tuxen & Hammerich Co.

A recent design of carbonic acid machine built by Mollet, Fontaine, et Cie, of Lille, France, consists of a single-acting compressor direct-driven by a horizontal steam engine. The arrangement for forming a gas-tight joint round the compressor piston rod comprises a stuffing box having three compartments, the two outer ones being filled with glycerine, a small portion of which is drawn in by the rod into the inner box or compartment to act as a lubricant. One of these compressors was exhibited at the late Paris Exhibition in the French brewery section.

Another carbonic acid machine shown at the above Exhibition was one built by Escher, Wyss, et Cie, Switzerland. This machine comprises a single compressor cylinder fitted with cast-steel valves on phosphor bronze seats, and driven direct by a horizontal 50 H.P. steam engine. The capacity of the machine is 12 tons of ice per twenty-four hours.

Thomas Ths. Sabroe & Co., Ltd., Aarhus, Denmark, are manufacturers of a vertical type of carbonic anhydride machine, which has the foundation plate of the compressor and the condenser cast in one piece, and all the parts made interchangeable. The general arrangement of the apparatus resembles that of Hall's vertical pattern machine.

Carbonic acid machines are also made by Wegelin & Hübner, Act.-Ges., Halle-on-Saale; D. Stewart & Co., Ltd., Glasgow; and others, whose machines the space at our disposal does not permit us to undertake to describe here.

CHAPTER VIII

CONDENSERS AND WATER COOLING AND SAVING APPARATUS

Submerged Condensers—Amount of Cooling Water Required—Atmospheric or Open-Air Evaporative Surface Condensers—Amount of Condenser Surface Required—Amount of Cooling Water Required—Supplementary Condensers or Forecoolers—Double-Pipe Condensers—Hendrick's Condenser—Water Cooling and Saving Apparatus—Water Cooling Towers.

As has been already mentioned in the fifth chapter, one of the three essential parts of any compression machine is the condenser, the function of which is to supplement the action of the compressor or pump.

The condensers in most general use may be classified under two main heads, the submerged type of condenser and the atmospheric or open-air evaporative surface type of condenser, the first having always some arrangement of coils immersed or submerged in a tank of cooling water, and the second invariably consisting of coils of pipe or tube exposed to the air, with water trickling over them.

SUBMERGED CONDENSERS.

The submerged type of condenser is the only one applicable in some cases, as for instance in marine installations; it has, besides, certain specific advantages which will be next treated of, but it may be premised that it consumes a large amount of cooling water, which, where water has to be paid for at a high figure, may amount to a serious item in the working expenses. The system, however, admits of the condenser being located in any part of the building, or in the open air, as may be desired, occupies comparatively little space, allows the cooling water to be admitted to the condenser at the bottom near the exit for the condensed gas, so that the water gradually rises as it becomes warmer, until it is discharged at the top, whilst the warm

gas entering the condenser at the top-header, flows downward through the coils, and parting with its sensible and latent heat to the cooling

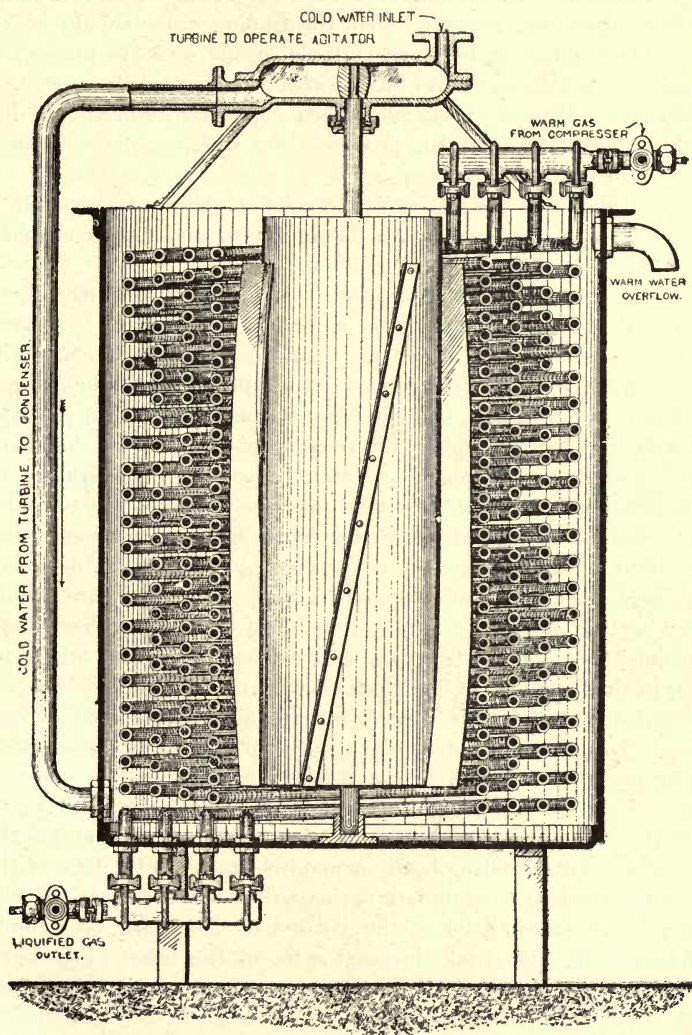

Fig. 89.—Chew's Patent Submerged Type Condenser. Vertical Central Section.

water becomes liquid and drains away to the bottom-header. And, finally, the submerged pipes in a condenser of this description remain

clean, and therefore in an efficient condition, much longer than they do when exposed.

To secure the utmost efficiency of a condenser of the submerged type it is absolutely necessary that the cooling water should be kept in a state of agitation by some suitable means so as to prevent the formation and collection of a film of warm water round the pipes.

Several condensers of the submerged type have been already illustrated, and briefly described, in connection with various compression machines, in previous chapters.

Fig. 89 shows in vertical central section a patent condenser of the submerged type, invented by Mr Leuig Chew, and manufactured by Messrs H. J. West & Co., Ltd., London.

The construction of this apparatus is almost sufficiently obvious from the drawing, and but little explanation is needed. A special feature is the automatic device for breaking up the above-mentioned film of warm water, and dispersing the air bubbles, thus bringing the cold water into intimate contact with the surfaces of the pipes, and promoting the most complete interchange of heat. This device consists of a revolving agitator, fitted with helical blades, which is slowly and automatically rotated by a small turbine fixed on the top of the condenser, and operated by the same water which is afterwards used to circulate through the condenser for cooling purposes. This arrangement offers the obvious advantage of saving the expenditure required for driving the agitator, as well as enabling the more or less complex arrangement of toothed gearing and belt pulleys, used when it is driven in that manner, to be dispensed with.

Compound submerged condensers are also constructed by some makers. In one arrangement of this description the hot gas from the compressor is first passed into a primary condenser, consisting of a single coil of pipe submerged in a tank; the gas and liquid leaving this coil at the bottom is passed on to a secondary condenser, and is there delivered by a distributing head, or manifold inlet, to the tops of three coils submerged in a second tank located above the first one. The cooling water is admitted to the bottom of the upper or secondary condenser tank, and is taken from the top of the latter to the bottom of the lower or primary condenser tank, and finally runs off by an overflow at the top of the latter.

In a better arrangement than the above the single-coil primary condenser, to which the hot gas from the compressor is first delivered, is located on the top, and the secondary condenser with three coils to which the gas and liquid is next passed, is placed below or under-

neath the former. The cooling water is, in this arrangement, delivered simultaneously to the bottoms of both condensers, and is finally run off in a like manner at the tops of them.

Fig. 90 shows a pattern of condenser patented by H. H. Schou, which is divided into two or more sections, connected so that the cross area of a section will be suited to the state and feed of the cooling medium therein. These separate coils are either of equal or different lengths, and may be arranged in several ways. In the form shown in the drawing the liquefied agent enters the coil marked *f*, and as it evaporates passes through the coupling *h*, coils *d*, *e*, coupling *i*, and coils *a*, *b*, *c*, from which the gas is removed by the pipe *g*.

A type of condenser, patented by Mr T. B. Lightfoot in 1885, consists of coils or zigzag pipes, arranged with one or more zigzag passages between them, formed in a tank or vessel, the arrangement being such that the water or refrigerating medium enters the coils or zigzag pipes at the bottom, the vapour being drawn off by a pump at the top, whilst the fluid to be cooled enters the tank or vessel at the top of the tank, and after travelling along the whole length of each coil or zigzag, is drawn off at the bottom.

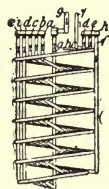

Fig. 90. —
Schou's Patent
Condenser.

The coils of pipe in a submerged condenser usually consist of $1\frac{1}{4}$ -in. to 2-in. pipe in one or more sections, preferably a number connected by manifold inlets and outlets, so that one or more of the sections may be shut off for repairs, &c. In some constructions the pipe at the vapour inlet end is of larger dimensions, and arranged to taper down to the outlet end, the agent being there partially liquefied, and occupying less space.

The amount of condenser surface to be employed is best determined by practice. According to Professor Siebel it has been found that for average conditions (incoming condenser water 70° and outgoing condenser water 80° , more or less) for each ton of refrigerating capacity (or for $\frac{1}{2}$ ton ice-making capacity) it will take 40 sq. ft. of condenser surface, which corresponds to 64 running feet of 2-in. pipe, or to 90 running feet of $1\frac{1}{4}$ -in. pipe. Frequently 20 sq. ft. of condenser surface, and even less, are allowed per ton of refrigeration (double that for actual ice-making capacity), but this necessitates higher condenser pressure, &c., and is deemed poor economy by many engineers.

The Triumph Ice Machine Co. give for their ammonia condensers

about 120 ft. of 1½-in. pipe, or 70 ft. of 2-in. pipe per ton. They also recommend at least 20 in. clearance space between the coils to admit of easy access to all parts; that the condenser should never exceed 20 ft. in length; and that it should never be above sixteen pipes high.

According to Professor Siebel* again the number of square feet of cooling surface F required in a submerged condenser may be approximately calculated after the formula—

$$F = \frac{hk}{m(t-t_1)} \text{ sq. ft.},$$

in which h is the heat of vaporisation of 1 lb. of ammonia at the temperature of the condenser, k the amount of ammonia passing the compressor per minute, and m the number of units of heat transferred per minute per square foot of surface of iron pipe, having saturated ammonia vapour inside, and water outside. t represents the temperature of the ammonia in the coils, and t_1 that of the cooling water outside of the coils, *i.e.*, mean temperature of the inflowing and outflowing cooling water. Taking the figures already given as a guide, the factor m is equal 0.5, so that the formula reads—

$$F = \frac{h.k}{0.5(t-t_1)} \text{ sq. ft.}$$

This formula, like others which have been given on this subject, is, it must be understood, an empirical or experimental one.

Referring to amount of cooling water required, the same authority observes that the heat which is transferred to the ammonia whilst producing the refrigeration, and also the heat equivalent to the work done upon the ammonia by the compressor (superheating being prevented), must be carried away by the cooling water, expressed in thermal units; and speaking theoretically, the sum of these two heat effects is equal to the heat of vaporisation of the ammonia at the temperature of the condenser. On the basis of this consideration, the amount of cooling water A_1 , in pounds required per hour, may be expressed by the formula—

$$A_1 = \frac{h.k \times 60}{t-t_1} \text{ lbs.},$$

or in gallons after division by 8.33, the signs having the same significance as in the foregoing formulas, with the exception of t , which represents the actual temperature of the outgoing, and t_1 , which repre-

* "Compend of Mechanical Refrigeration," H. S. Rich & Co., Chicago, 1899.

sents the actual temperature of the incoming cooling water. Practically the amount of water used varies all the way from 3 to 7 gals. per minute per ton ice-making capacity in twenty-four hours.

The following table, compiled by Mr Eugene T. Skinkle, gives the dimensions of submerged condensers of some plants in actual operation in the United States:—

DIMENSIONS OF SUBMERGED CONDENSERS.

| Ice-making Capacity in Tons. | Refrigerating Capacity in Tons. | Tanks. | | | | Number of Coils. | Pipes High. | Feet Long. | Size of Pipe in Inches. | Total Feet of Pipe in Condenser. | Feet of Pipe per Ton. Ice-making Capacity. | Feet of Pipe per Ton. Refrigerating Capacity. |
|------------------------------|---------------------------------|-----------------|-----------------|------------------|------------------------------|------------------|-------------|------------------|-------------------------|----------------------------------|--|---|
| | | Length in Feet. | Width in Feet. | Depth in Feet. | Thickness of Iron in Inches. | | | | | | | |
| 5 | 10 | 10 | 3 $\frac{1}{2}$ | 6 $\frac{1}{2}$ | $\frac{3}{8}$ | 9 | 12 | 7 $\frac{1}{2}$ | 1 | 855 | 171 | 85.5 |
| 10 | 20 | 10 | 7 $\frac{1}{2}$ | 6 $\frac{1}{2}$ | $\frac{3}{8}$ | 20 | 12 | 7 $\frac{1}{2}$ | 1 | 1,900 | 190 | 95. |
| 12 $\frac{1}{2}$ | 25 | 10 | 7 $\frac{1}{2}$ | 6 $\frac{1}{2}$ | $\frac{3}{8}$ | 22 | 12 | 7 $\frac{1}{2}$ | 1 | 2,090 | 167 | 83.6 |
| 15 | 30 | 10 | 8 $\frac{1}{2}$ | 6 $\frac{1}{2}$ | $\frac{3}{8}$ | 25 | 12 | 7 $\frac{1}{2}$ | 1 | 2,375 | 151.6 | 79.16 |
| 20 | 35 | 10 | 10 | 6 $\frac{1}{2}$ | $\frac{3}{8}$ | 27 | 12 | 7 $\frac{1}{2}$ | 1 | 2,565 | 128.25 | 73.28 |
| 30 | 50 | 10 | 10 | 12 $\frac{1}{2}$ | $\frac{3}{8}$ | 27 | 24 | 7 $\frac{1}{2}$ | 1 | 5,130 | 171 | 102.6 |
| 40 | 75 | 14 | 10 | 13 $\frac{1}{2}$ | $\frac{3}{8}$ | 27 | 24 | 11 $\frac{1}{2}$ | 1 | 7,695 | 191.1 | 102.6 |
| 60 | 110 | 14 | 13 | 13 $\frac{1}{2}$ | $\frac{3}{8}$ | 35 | 24 | 11 $\frac{1}{2}$ | 1 | 9,975 | 166.25 | 90.68 |
| Average - - - - | | | | | | | | | | | 167. | 89. |

ATMOSPHERIC OR OPEN-AIR EVAPORATIVE SURFACE CONDENSERS.

In this class of condenser the lines of pipes or tubes through which the agent passes are so located as to be exposed to more or less constant currents of air, and generally, in addition to the latter, cooling water is caused to trickle over the pipes. The vaporised agent should preferably be passed in this arrangement in an opposite direction to the cooling water. That is to say, it should be admitted at the bottom of the condenser, and in this case the liquid, as fast as it is formed, passes off to the side into a vertically-placed manifold. By this means the warm gas entering the condenser meets the warmer water, and the gas as it ascends in the condenser constantly meets colder water, until its temperature is nearly reduced to that of the water when it first comes in contact with the condenser pipes, liquefaction then taking place.

Atmospherical condensers which are said to give excellent results are also formed of vertical sections of pipe, the compressed vapour being delivered to each section at the top from a common manifold or

distributing head, and discharging the liquid at the bottom into another common manifold or distributing head, which latter is connected with the liquid receiver.

The ordinary form of atmospheric condenser is of very simple construction, and consists essentially of a stack of tubes placed in lines, with return bends and heads, and some water-distributing arrangement. Fig. 91 is a diagram showing a simple plan for distributing the water, which is self-explanatory. It will be noted that the cooling water should pass through an exactly contrary sequence to that undergone by the compressed vapour, viz., during its downward course it should

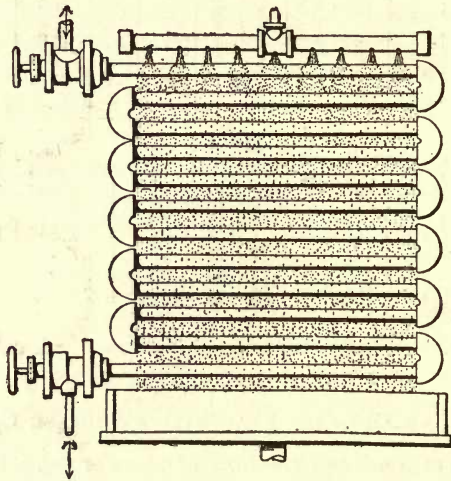

Fig. 91.—Diagram showing Simple Method of Distributing Water in Atmospheric Condenser.

constantly meet warmer gas or vapour, and consequently be gradually increased in temperature until it finally leaves the condenser by the trough shown at the bottom. By means of this gradual extraction of heat the difference between the initial and final temperature of the water will be greater than could be obtained were the gas and the water to flow in the same direction. In the De La Vergne, Eclipse, and other standard American condensers, the gas enters at the bottom, whilst the cooling water is applied at the top.

In Fig. 92 is a diagram showing a common arrangement for the distribution of water, R indicating the water trough in transverse section, and s the condenser tubes through which the hot gas or vapour passes.

This arrangement, it will be seen, results in the water spattering to such an extent that partitions have to be provided between and at the ends of the series of vertical coils. Fig. 93 shows diagrammatically a very simple plan, given in an American journal, for avoiding this objectionable spattering, which consists of a strip of metal or fin, *t*, which is attached to the underside of each of the condenser pipes or tubes *s*, and which serves to guide the water falling from the trough *r* quietly to the top of the pipe or tube below where the stream divides, one-half pass-

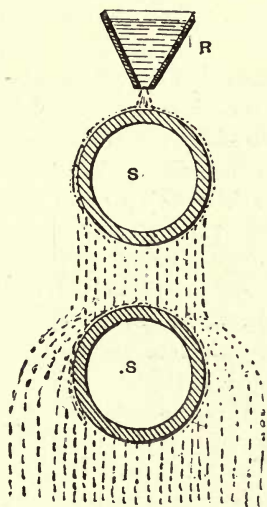

Fig. 92.—Diagram showing Objections to Common Plan of Distributing Water in Atmospheric Condensers.

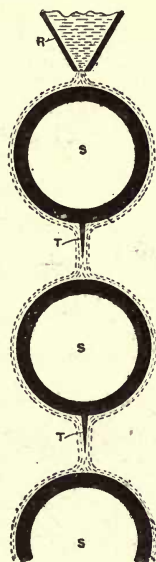

Fig. 93. — Diagram showing Method of avoiding Spattering in Distributing Water in Atmospheric Condenser.

ing down and round one side of the tube, and the other half down the other side of the tube as shown.

Fig. 94 shows an arrangement adopted by some American and other makers for removing the liquefied agent from the condenser, and delivering it into the storage tank, as soon as formed. This is effected by the introduction of drip-pipes *v*, connected with the return heads *u* of several of the coils of pipe or tube *s*, and with the storage tank or liquid receiver *w*, so as to draw off the liquid at different levels.

In this manner the liquid formed near the top of the condenser at a lower temperature is prevented from falling to the warmer lower coils, in which a reabsorption of a certain amount of heat would take place, with a resultant loss of work.

Fig. 95 illustrates an open-air evaporative surface condenser, built by Messrs Haslam, of Derby, which is arranged to work upon the principles above enunciated, by which the greatest possible amount of efficiency is secured. The condenser shown is built in a nest of five sections, thus rendering it more convenient for transport, and also admitting of easy access being had to all parts of the apparatus for repairs. Each section is provided with independent valves and cocks, so that any particular section may be shut off at any time if desired.

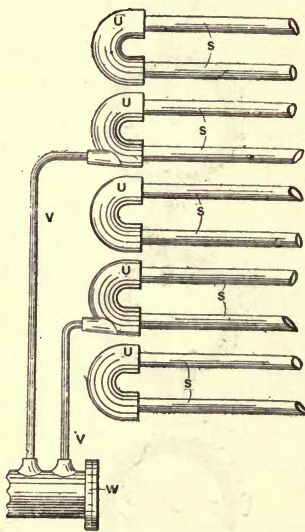

Fig. 94.—Arrangement for Removing Liquefied Agent from Atmospheric Condenser.

Fig. 96 shows the Haslam interlaced type of ammonia condenser. In this pattern each nest is composed of three independent coils of pipe welded into one continuous length. The ends of the three coils are connected to headers at the top and at bottom, thus making each nest complete in itself. Valves are provided to isolate each nest, and these in turn are connected by headers, the number of nests being in accordance with the size of the machine. A slotted pipe is provided at the top of each nest to distribute the water, which in this type of condenser is generally circulated over and over again, being cooled by evaporation into the atmosphere. This

type of condenser is useful where water is scarce, only a small quantity being required to make up the losses due to evaporation, wastage, &c.

In Fig. 97 is illustrated an atmospheric or open-air condenser made by the Triumph Ice Machine Co., Cincinnati. This condenser is arranged in sections, and is so constructed as to permit of the ready removal of any pipe or fitting, without the necessity for shutting down the plant or losing any of the agent. The apparatus has double, extra heavy, wrought-iron pipe headers.

The atmospheric condensers designed and manufactured by the Fred. W. Wolf Co., of Chicago, has pipes made from selected skelp, with drop-forged Bessemer steel flanges screwed on to same whilst hot, thus admitting of its shrinking in place when cool. Galvanised iron troughs, fitted with a patent levelling device, are provided for distributing the cooling water, and perforated steel strips are secured between the pipes. An inlet and an outlet valve are fitted to each section, so that anyone of them can be emptied without interfering with the operation of the others.

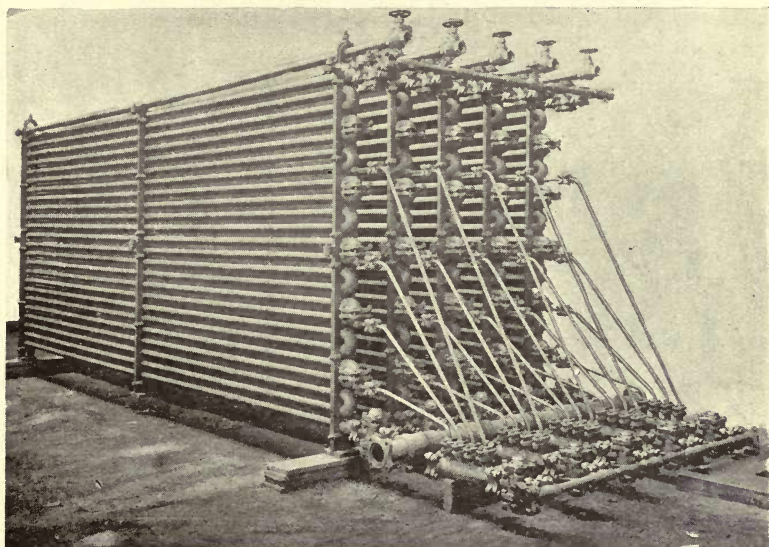

Fig. 95.—Haslam Atmospheric or Open-air Evaporative Surface Condenser.

In Fig. 98 is illustrated an atmospheric or open-air evaporative surface condenser, built on Rau's system, with either copper or iron pipes, by Quiri & Co., Schiltigheim, Alsace. The construction of this condenser will be readily understood from the engraving.

Evaporative condensers are also cooled by artificial currents of air, propelled by a fan or blower, in which case a very powerful evaporation is established. Whether or not an arrangement of this description would prove to be an economical one, depends upon the temperature and cost of the cooling water procurable relatively to the cost of driving the fan.

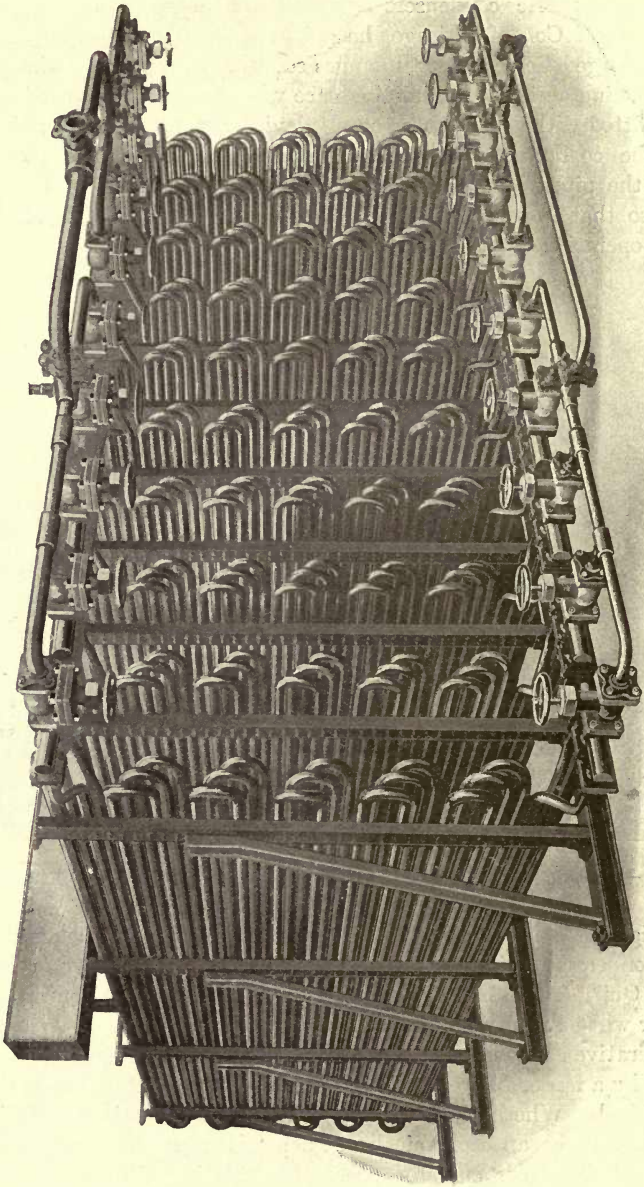

Fig. 96—Haslam Interlaced Type of Ammonia Condenser.

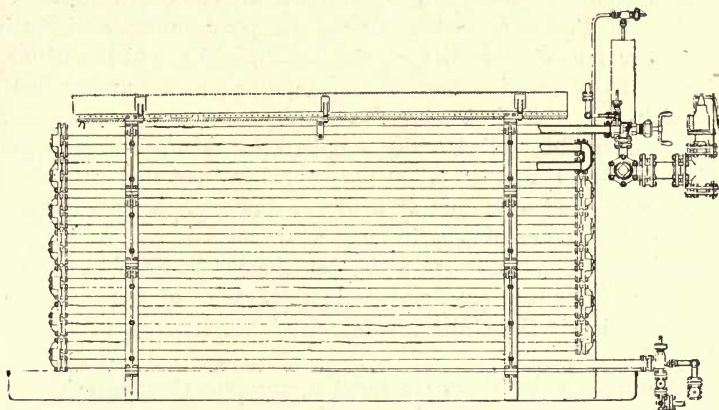

Fig. 97.—Triumph Atmospheric or Open-air Evaporative Surface Condenser.

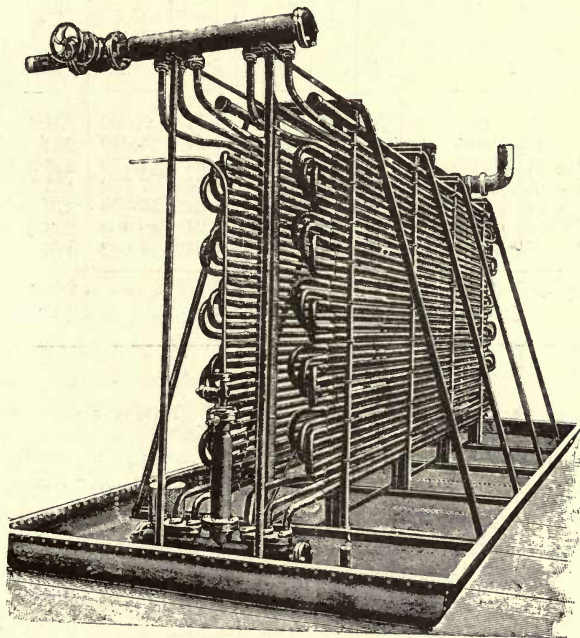

Fig. 98.—Rau's Atmospheric or Open-air Evaporative Surface Condenser

The amount of condensing surface for an open-air condenser is, according to Professor Siebel, 40 sq. ft. per ton of refrigerating capacity (or for one-half ton ice-making capacity), which amount is equivalent to 64 running feet of 2-in. pipe or to 90 running feet of $1\frac{1}{4}$ -in. pipe.

The amount of cooling water required for an open-air or atmospheric condenser is upward of 50 per cent. less than that required for a submerged condenser, and if made of sufficient height, the same water may be used repeatedly in an open-air condenser.

The following table, compiled by Mr Eugene T. Skinkle, gives the dimensions of open-air or atmospheric condensers of some plants in actual operation in the United States:—

DIMENSIONS OF OPEN-AIR OR ATMOSPHERIC CONDENSERS.

| Ice-making Capacity in Tons. | Refrigerating Capacity in Tons. | Condenser Pans. | | | | Number of Pipes High. | Number of Pipes Wide. | Size of Pipe in Inches. | Length of Coil over Bends in Feet. | Total Feet of Pipe in Condenser. | Feet of Pipe per Ton, Ice-making Capacity. | Feet of Pipe per Ton. Refrigerating Capacity. |
|--|------------------------------------|---------------------------|--------------------------|----------------------------|---------------------------------|--------------------------|--------------------------|-------------------------|---------------------------------------|-------------------------------------|---|---|
| | | Length of Pan in Feet. | Width of Pan in Feet. | Depth of Pan in Inches. | Thickness of Iron in Inches. | | | | | | | |
| 12 $\frac{1}{2}$ | 25 | 21 | 10 $\frac{3}{8}$ | 8 | $\frac{3}{16}$ | 40 | 5 | 1 | 17 | 3,680 | 294.4 | 147.2 |
| 20 | 35 | 24 $\frac{1}{2}$ | 10 $\frac{3}{8}$ | 8 | $\frac{3}{16}$ | 40 | 5 | 1 | 21 | 4,440 | 222 | 126.8 |
| 30 | 50 | 24 $\frac{1}{2}$ | 14 | 8 | $\frac{3}{16}$ | 50 | 7 | 1 | 21 | 7,750 | 258.3 | 155 |
| 40 | 75 | 24 $\frac{1}{2}$ | 14 | 8 | $\frac{3}{16}$ | 50 | 7 | 1 $\frac{1}{4}$ | 21 | 7,750 | 193.75 | 103.33 |
| 50 | 100 | 24 $\frac{3}{8}$ | 14 | 8 | $\frac{3}{16}$ | 90 | 7 | 1 | 21 | 13,950 | 279 | 139.5 |
| 60 | 125 | 24 $\frac{1}{2}$ | 14 | 12 | $\frac{3}{16}$ | 80 | 7 | 1 $\frac{1}{4}$ | 21 | 12,400 | 206.6 | 99.2 |
| 80 | 150 | 27 $\frac{1}{2}$ | 17 | 12 | $\frac{3}{16}$ | 80 | 7 | 1 $\frac{1}{4}$ | 24 | 14,080 | 176 | 93.86 |
| Average for 1-in. pipe per ton | | | | | | | | | | - | 263.42 | 142.12 |
| Average for $1\frac{1}{4}$ -in. pipe per ton | | | | | | | | | | - | 192.12 | 98.79 |

SUPPLEMENTARY CONDENSERS OR FORECOOLERS.

An arrangement intended to create a saving of power and of cooling water is a supplementary condenser or forecooler consisting of one or more coils of pipe through which the hot compressed gas is caused to pass before entering the main condenser. This supplementary condenser is cooled by the overflow water from the main condenser. When the supplementary condenser consists of one coil only it should be equal in size to the discharge pipe from the compressor. Should a series or number of coils be provided, however,

the manifold pipe and the aggregate area of the small pipe openings should be equal to that of the discharge pipe.

WESTERLIN-CAMPBELL AND HASLAM DOUBLE-PIPE CONDENSERS.

The Westerlin-Campbell condenser, which is shown in side and end elevation in Figs. 99 and 100, consists of a coil made up with one pipe inside another, the water being on the inside of the internal pipe, and the hot compressed gas in the annular space or clearance between the pipes. This type of condenser is an attempt to secure the best features of both the submerged and atmospheric types in one apparatus, and is specially suitable wherever the water is to be used over again for some other purpose, and where the open-air type cannot be used by reason of structural difficulties. The hot gas is arranged to travel in a downward direction, and the cooling water in an upward direction, so effecting an interchange of temperature that results in the warmer water meeting the current of the warmest gas. The condenser is constructed in a nest, comprising several sections or stands, so that any one section can always be cut out for repairs, without having for that reason to shut down the plant, and such a cross connection of the water connections is provided that the water current can be reversed when it is desired to wash out the internal pipe.

Fig. 101 illustrates the Haslam type of double-pipe ammonia condenser. The pipes containing the ammonia gas to be condensed are 2-in. bore, built up in the same manner as the other Haslam condensers, and through the centre of each a $1\frac{1}{4}$ in. bore pipe passes. These are connected at the ends by U-shaped bends removable for cleaning purposes, and through this inner pipe the cooling water passes, being thus brought into intimate contact with the ammonia.

An advantage of this type of condenser is that the water may be maintained under pressure, and raised to a height to be used for other purposes afterwards without further pumping. No tray is required under condensers of this type.

An objection to this type of condenser would appear to be the liability of the deposit of scale in the pipes from certain classes of water.

HENDRICK'S CONDENSER.

This type of condenser differs from those previously described. It consists essentially of a vertical cast-iron shell, containing two or more spiral coils of $1\frac{1}{4}$ -in. pipe of extra thick gauge, the tail ends of

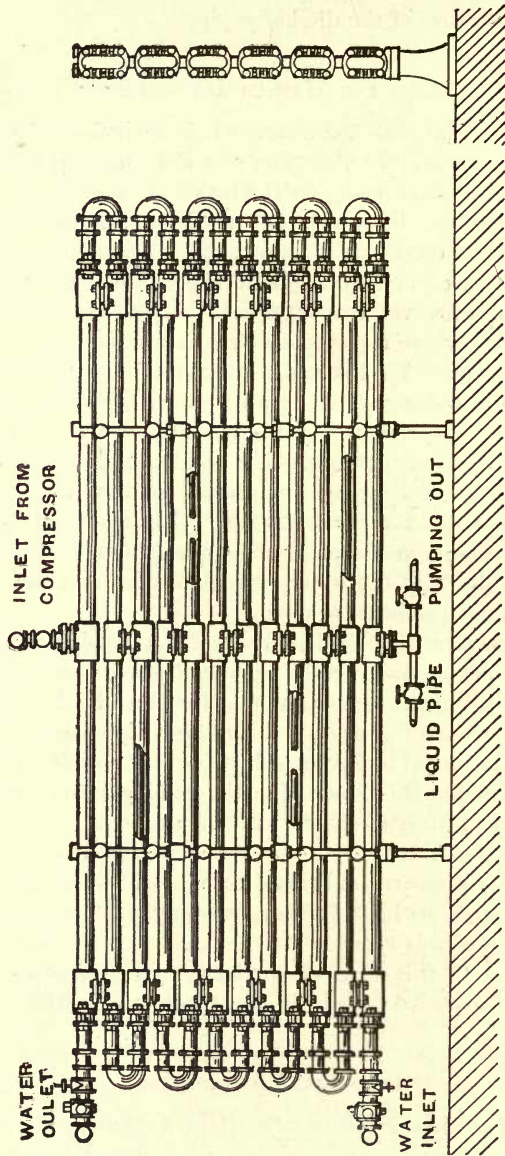

Figs. 99 and 100. —Westerlin-Campbell Double-Pipe Condenser. Side and End Elevations.

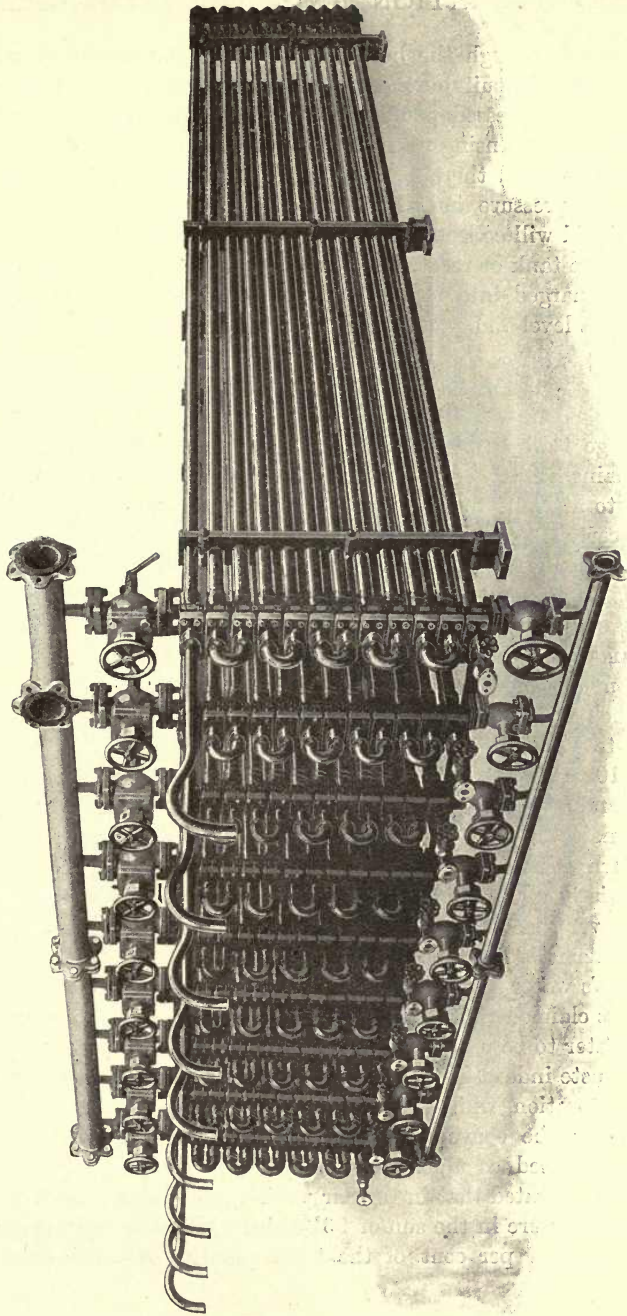

Fig. 101. — Haslam Double-Pipe Ammonia Condenser.

which project through the heads or covers of the shell and are connected together by suitable manifolds.

The hot compressed gas is delivered into the upper part of this shell, and the condensing water is circulated through the spiral coil or coils of pipe located therein. The hot compressed gas is liquefied by reason of the pressure and by coming into contact with the coil or coils, and the liquid will collect at the bottom of the shell, which thus forms also a storage tank or receiver for the anhydrous liquid, from which it can be discharged into the evaporator or refrigerator. The shell is fitted with a level and gauge to indicate the amount of liquid therein.

WATER-COOLING APPARATUS.

In large towns and cities where the water from the water companies' mains has to be used, and paid heavily for, it is often doubtful economy to attempt to reduce the temperature of the condensed gas below a certain point, say 60° Fahr. during the winter months, and 70° Fahr. during the summer months. It is obvious that when a high price has to be paid for the water employed for cooling and other purposes, every effort possible should be made to utilise it to the fullest extent, and, with this end in view, it is desirable to use the overflow water from the condenser for boiler-feeding purposes, or to employ some means, such as a cooling tower, for saving that which would be otherwise run to waste and be completely lost.

Fig. 102 shows the Haslam type of open water cooler, which is a simple and at the same time efficient apparatus. It consists of one or more nests of lap welded wrought-iron pipe, fitted with malleable iron return bends and flanges. Through these pipes the liquefied ammonia is evaporated, and the water to be cooled is distributed in a thin film over the cooler by means of a slotted pipe placed over same. As the water falls it is cooled to any desired temperature.

Puplett's water saving and cooling apparatus is illustrated in Fig. 103. It is claimed that the use of this contrivance enables the condensing water to be used over and over again with comparatively little loss, the waste indeed being practically confined to the quantity taken up by evaporation, which loss is, of course, more considerable in hot weather, and the consumption of condensing and circulating water is thus minimised as much as possible. It is stated to have been clearly demonstrated that in regular working for a considerable period, with a temperature in the sun of 93° Fahr., the entire loss experienced did not exceed 3 per cent. of the total quantity of water circulated.

The cost of the upkeep of the apparatus, moreover, is trivial, being one farthing per thousand gallons cooled, and the power required under ordinary conditions is 1 H.P. indicated for the same amount.

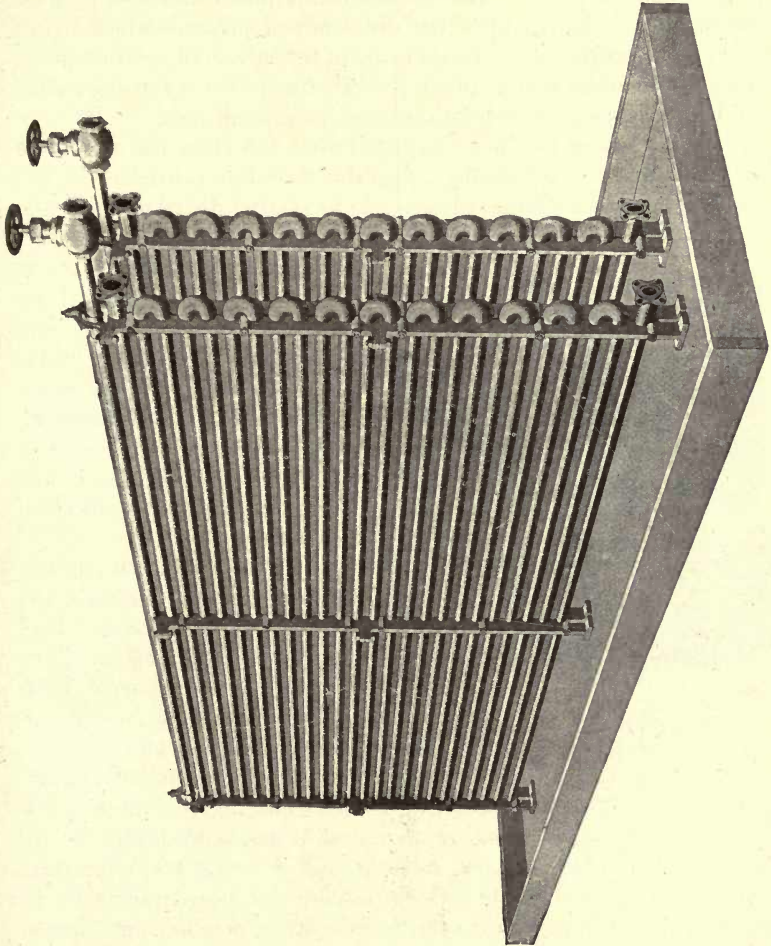

Fig. 102. — Haslam Open Type of Water Cooler.

The scope of this work does not admit of entering into an extended dissertation upon what are known as cooling towers, consequently space can only be found for a few general remarks and very brief descriptions of some examples of water-cooling towers, with which this chapter will be brought to a conclusion.

First, as regards the general efficiency of any apparatus of the kind under consideration, this will be found to depend upon the following three principal points, viz. :—The extent of the water surfaces exposed. The quantity of air that is brought into contact with those surfaces. And, thirdly, upon the difference of pressure which exists on the vapours at the water surfaces, and in the surrounding atmosphere. The first two will be seen to relate to the construction of the apparatus, the third to the general or normal atmospheric conditions.

From the above it will be gathered that the chief features to be looked for in a water-cooling apparatus are the provision of the maximum amount of cooling surface, the most even distribution of the

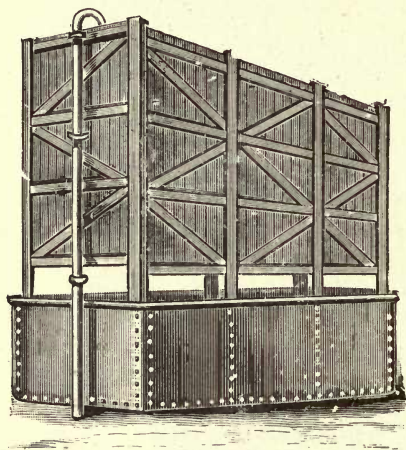

Fig. 103.—Puplett's Water Saving and Cooling Apparatus.

water over this cooling surface possible, and an effective air circulation. Cooling towers are extensively employed in the United States in connection with refrigerating plants, and the following very brief descriptions of a few of the best known will give an idea of their construction.

The Worthington consists of a steel tower enclosing the evaporating surfaces, which latter are formed of hard glazed tiles, supported upon T-beam grating, or of regalvanised tube tiling.

The Klein is constructed entirely of wood, a polygonal vertical shaft forming the frame for a checker-work of boards, which are arranged in horizontal layers.

The Stocker, which consists essentially of a strong wooden casing, the interior of which is made up of cross-pieces of boards arranged in horizontal layers set at right angles to each other, and having between their intersections upright oblique partitions. The water is distributed by a system of funnel-shaped troughs at the top of the structure.

The Barnard has a steel casing within which are hung a number of mats made of a special galvanised wire cloth.

In all these cooling towers except the Stocker one fan only is employed, the latter has two fans mounted upon one steel shaft at the

base of the apparatus, which arrangement is claimed to enable a more equal distribution of the air to be effected, and a saving of driving power, as compared with the amount of air discharged.

The Zschocke cooling tower is also said to afford first-rate results, and to be most economical in working. This apparatus consists essentially of a main distributing water-trough located above the cooler, into which the water to be dealt with is delivered direct, or, where it consists of injection water carrying a considerable amount of oil, after passing it through an oil filter. In the walls of this main distributing trough, and near its bottom, are fitted a number of small iron pipes, through which the water will pass into a series of smaller distributing troughs, the walls of which are serrated both top and bottom, so as to cause the water to be distributed in drops over the top layer of the wooden battens composing the body of the cooler. These battens are evenly spaced, and are placed at a slight inclination, so that each drop of water will be caught and broken on the rough surface, and will spread itself out into a thin film, which will flow down each of the battens, and again form itself into drops on the lower edge of it, owing to its being also serrated, and will fall on to the next batten in the layer below, and so on, until the

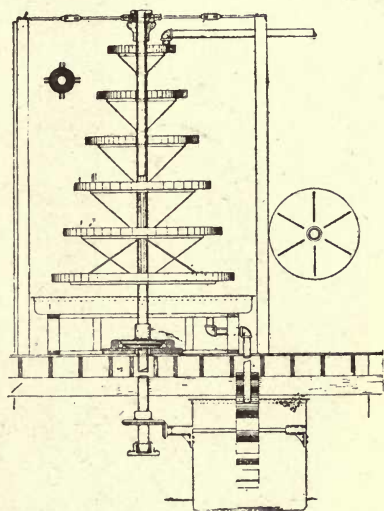

Fig. 104.—Triumph Water-Cooling Tower. Elevation.

bottom or lowermost layer is reached. The air has free access to every batten, and consequently as the water parts with a portion of its heat at each, it will fall into the receiving tank beneath in a suitably cooled condition. The open type of cooling tower is provided at the sides with louvres, which serve to prevent the water from being blown away in the case of strong winds, whilst at the same time admitting air to every part.

The Triumph Ice Machine Co.'s water-cooling tower is shown in Fig. 104. This apparatus works on the principle of exposing the water to be cooled in a thin sheet to the cooling effect of the atmo-

sphere, the result being said to be increased in the above tower by imparting to it a rotary motion against the air current. This rotary

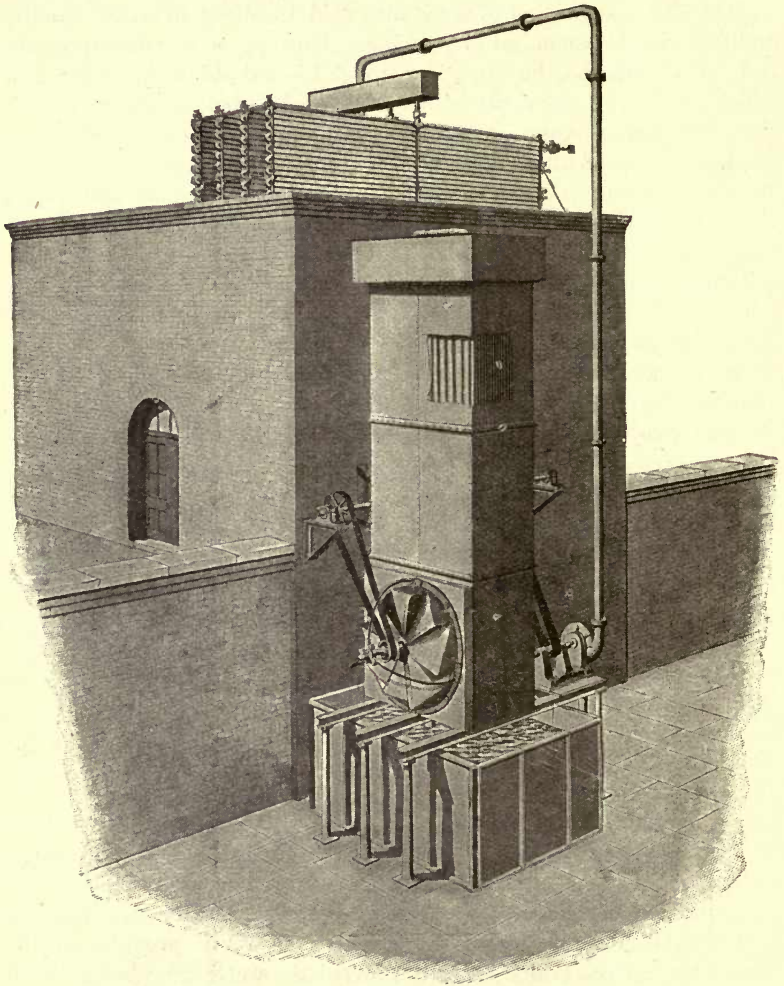

Fig. 105.—Haslam Water-Cooling Tower.

motion is given by a small water-wheel in the manner plainly shown in the illustration.

A cooling device made by the Linde Company for use in connection

with submerged condensers consists of the following arrangements:— The condenser pipes are placed in an iron tank, the cooling water being kept in motion by a stirrer. At the top of the tank is provided a number of sheet-iron cylinders, so arranged that they are immersed in the water below to the extent of about one-third of their diameter. These cylinders are caused to rotate slowly upon their axis, and their water-covered surfaces are subjected to the action of a current of air generated by a fan, the consequent evaporation producing the cooling effect. This apparatus is identical in principle to the Wetzal pan for concentrating the syrup or liquor in the manufacture of sugar.

Fig. 105 illustrates the Haslam water-cooling tower, which consists of a wrought-iron casing containing galvanised corrugated wrought-iron plates. The overflow water from the condensers enters the cooler at the top and falling over the plates, comes in contact with a current of air induced by the fan shown in the drawing. The cooled water falls into a tank under the cooler, and is again raised to the distributing tank over the condensers by a centrifugal pump.

CHAPTER IX

THE ABSORPTION AND BINARY ABSORPTION PROCESS OR SYSTEM

The Principle of the Absorption Process—Early Machines—Later Patterns of Machines—The Binary Absorption Process, or Machines using a Compound or Dual Liquid.

THE principle involved in the operation of machines for the abstraction of heat by the evaporation of a separate refrigerating agent of a volatile nature under the direct action of heat, and without the use of power, which agent again enters into solution with a liquid, is, as has been previously observed of the liquefaction process, more a chemical or physical action than a mechanical one. It is founded upon the fact of the great capacity possessed by water for absorbing a number of vapours having low boiling points, and of their being readily separable therefrom again, by heating the combined liquid; hence it is commonly known as the absorption process.

The absorption process was invented by Ferdinand Carré (brother to Edmond Carré, whose sulphuric acid freezing apparatus has been previously mentioned) about the year 1850. This system involves the continuous distillation of ammoniacal liquor, and requires the use of three distinct sets of appliances, viz. :—

First, for distilling, condensing, and liquefying the ammonia. Second, for producing cold, by means of a refrigerator, and absorber, a condenser, a concentrator, and a rectifier. Third, pumps for forcing the liquor from the condenser into the generator for redistillation. The three operations are each distinct from the other, but when the apparatus is in actual work they must be continuous, and are dependent upon one another, forming separate stages of a closed cycle.

An advantage of the absorption process is that the bulk of the heat required for performing the work is applied direct without being transformed into mechanical power. The first machines, however, constructed upon this principle were very imperfect in operation, by reason of the impossibility of securing an anhydrous product of dis-

tillation, and as the ammonia distilled over contained as much as 25 per cent. of water, a very large expenditure of heat was required for evaporation, and the working of the apparatus, moreover, was rendered intermittent. This was owing to the distillation, which is the most important operation, and has of necessity to be executed in a rapid manner, being, in the first machines, very imperfectly effected, and the liquor resulting therefrom being naturally much diluted with water. Another serious result of the above defect was the accumulation of weak liquor in the refrigerator, and the consequent necessity for constant additions of ammonia.

By subsequent improvements, however, made by Rees Reece in 1867-70; Mort in 1870, who introduced an improved temperature exchanger or economiser; H. F. Stanley, 1875; F. Carré (the original inventor), in 1876; W. H. Beck, in 1886; Mackay and Christiansen, and E. H. Tomkins, in 1887; and later still in the same year by E. L. Pontifex, the distillate has been rendered nearly anhydrous, and absorption machines have been brought to a very considerable degree of efficiency.

In Fig. 106 is illustrated F. Carré's continuous-acting absorption machine. As above mentioned, the agent employed in this apparatus is ammonia. In the drawing A indicates the generator, B is the liquefier, C is the refrigerator, D is the absorber. Aqua ammonia is introduced into the generator A, the level of the liquid being indicated by a gauge glass, which is shown on the left-hand side of the generator, and which is practically similar to that used on steam boilers, and the evaporation is effected by heat from the furnace shown beneath. The gas from the generator A is conducted by a suitable pipe E to the liquefier B, wherein it passes through a congeries or series of coils or zigzags arranged in a bath of cold water, which is kept constantly renewed from the reservoir F. By the time the ammonia has reached a vessel situated at the termination of the coils or zigzags in the liquefier it is in a liquid condition, and under a pressure of about 150 lbs. per square inch, which pressure is constantly maintained in the generator A.

In the liquid state the ammonia flows through the pipe G to the regulator H, by which it is admitted to the distributor I through a pipe K, which latter is wound spirally round the pipe or tube L, which is of larger bore, and through which the vaporised or gasified ammonia returns from the refrigerator C after having performed its heat-absorbing duties therein. By this arrangement the returning vapour or gas is made to do some further work by absorbing or taking up heat from the liquid ammonia on its way to the refrigerator.

The refrigerator represented in the drawing consists of a set or series of six or other suitable number of spiral or zigzag tubes c^1 , c^1 , which return upon themselves, forming an equal number of partitions

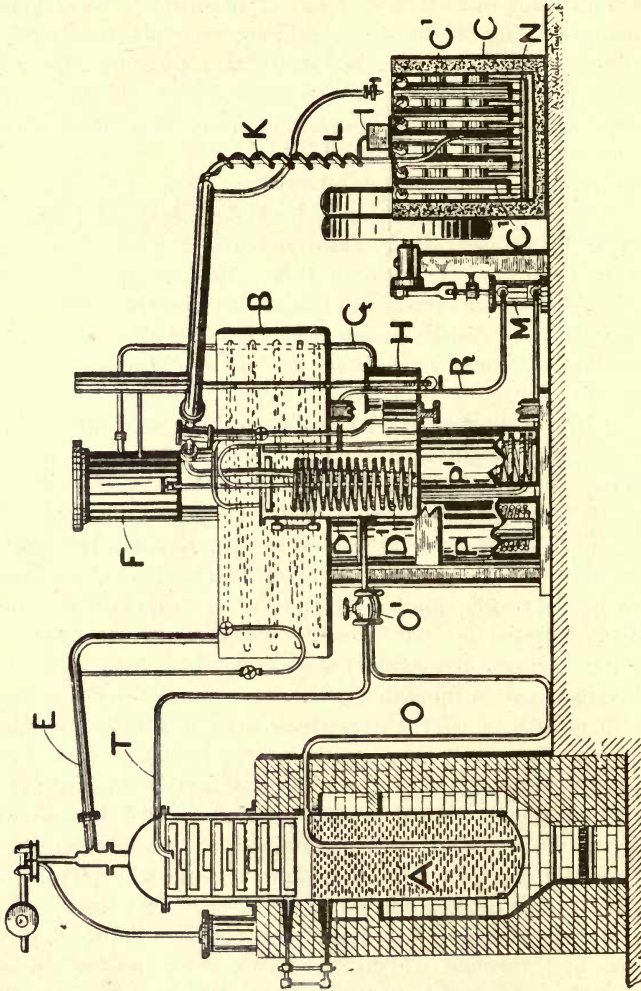

Fig. 106.—Carré's Continuous-Acting Ammonia Absorption Machine.

in the tank wherein they are immersed, which latter is lagged with suitable non-conducting material. Each of these zigzags receives an equal supply of the liquid ammonia from the distributor I , and the

space in the insulated tank surrounding them is filled with some uncongealable liquid, or one that will congeal only at very low temperatures, such as alcohol, or a solution of chloride of calcium or of common salt, which is usually known as brine.

The ice cans or cases are immersed in the liquor between the zigzags, and are sustained upon a carriage capable of being moved by the same mechanism that works the pump M, by which the re-saturated solution of ammonia and water is returned to the generator.

The ammonia gas or vapour from the zigzags in the refrigerator C is collected in the cylindrical vessel X, from which it passes up through the tube L to the absorber D, where it meets the water that has been brought from the bottom of the generator A, and which partially fills the latter. This water being nearly free from ammonia, it having been exhausted therefrom by evaporation in the generator A, greedily absorbs or takes up the ammonia gas or vapour injected into it from the tube L.

The absorber D is fitted with a worm D¹ which receives cooling water from the supply tank F, and the water from the generator A, which is brought by the pipe O, is first passed through the coolers P, P¹, before delivery into the absorber D, and is thereby cooled so as to fit it to absorb the ammonia gas or vapour in the absorber D more freely.

The transference of the water from the bottom of the generator A to the absorber D is effected by the pressure in the former, whenever the stop-cock or valve o¹ in the pipe O is opened. The pipe O is carried in a double coil through the cooler P, which consists of two concentric cylinders, and in a single coil through the cooler P¹, discharging through a sieve, strainer, or perforated tray, in a fine shower into the absorber D. The strong ammoniacal solution from the absorber D, which is considerably reduced in temperature, is passed through the spaces round the coils of pipe O in the cooler P, and whilst reducing the temperature of the hot exhausted solution or water from the bottom of the generator A on its way to the absorber D, is itself raised several degrees before being returned to the generator, to the mutual advantage of both. The coil of pipe O, in the second cooler P¹, is water cooled from the supply tank F.

The saturated solution from the absorber D is drawn off by the force pump M (which is driven by a steam engine or other motor), through the pipe R, and is delivered thereby to the space round the coil in the cooler P, passing from the cooler, through the pipe T, to the dome on the upper part of the generator A, where it falls upon, and trickles downward through, a series of perforated strainers or trays, whilst the ascending ammoniacal gas or vapour, on the other hand,

takes a sinuous upward course, alternately passing round the edge of one of the trays, and through a central hole or aperture provided in the next, and so on to the gas or vapour pipe E; any aqueous vapour, which might otherwise be carried off with the ammoniacal gas or vapour, being thus condensed and returned to the generator.

The constant pressure maintained in the generator A is, as already mentioned, about 150 lbs. per square inch, and to prevent this pressure from being exceeded a safety valve is provided on the dome of the generator. And gas that escapes through this safety valve is led through a suitable pipe to a small water tank, where it is absorbed.

As will be seen from the above description, the operation is, shortly, as follows:—

The aqua ammonia is first introduced into the generator A, the gas or vapour expelled therefrom by heat into the condenser B; and so that the process may be carried out continuously and not be arrested by the exhaustion of the solution, the exhausted or impoverished liquor is slowly drawn off at the bottom of the generator, an equal volume of fresh strong solution being constantly inserted at the top thereof. The united effects of the cooling and pressure produce liquefaction of the ammoniacal gas or vapour in the condenser, and the liquid ammonia passes to the refrigerator. It will be seen that the ammoniacal gas or vapour from the tubes of the refrigerator is re-absorbed, and a rich solution is formed to feed the generator, the absorbing water used being that withdrawn exhausted from the latter. Thus the generator and the condenser will keep up a continuous supply of the liquid, and the refrigerator will continue to freeze successive charges of water in the ice cans or cases, provided, however, that the requisite heat to vaporise or gasify the ammonia is supplied to the generator. If, therefore, the entire apparatus be perfectly fluid-tight, as it is theoretically supposed to be, no escape could take place by leakage or otherwise, and the same materials would go on indefinitely producing the same uniform effect.

In starting a machine constructed on the absorption principle it must be first blown through to expel all the air. In Carré's apparatus the air escaping from the absorber is conducted by a suitable pipe into what is known as a purger, where it is passed below the surface of water to absorb or retain any ammonia that would otherwise escape with the air.

A large amount of water is required for cooling purposes in the condenser or liquefier, and absorber, and a considerable consumption of fuel is also necessary to heat the generator, when this is performed

directly by means of a furnace, as above described; when, however, this is effected by steam-heated pipes, as in Stanley's 1875 patent, or, as will be described later on, by coils of pipe heated by the exhaust steam from an engine, or even by direct or live steam from a boiler, there is a considerable saving on this head. Steam or other motive power is likewise required for driving the force pump.

It is claimed by Mr Carré that for each pound of coal consumed as fuel, from 8 to 12 lbs. of ice can be produced, in accordance with the size of the apparatus. For working the larger form of machine, capable of making 500 lbs. of ice per hour, two men are required; the force pump is capable of forcing 220 gals. of liquid per hour into the generator, and during the same time 100 lbs. of pure ammonia is liberated from solution, liquefied, evaporated, and re-dissolved or re-absorbed.

Rees Reece's chief improvement is founded on the fact that two vapours having different boiling points, when united, can be recovered by fractional condensation, and by means of his apparatus a practically anhydrous distillate can be obtained.

The special feature in the invention described in his 1867 patent is the method of obtaining nearly anhydrous liquid ammonia by means of an analyser, a rectifier, and a condenser, the peculiar construction and arrangement of which enables a continuous distillation and rectification of a dilute solution of ammonia to be effected upon the separative principle. The ammoniacal gas is reduced by its own pressure to a liquid condition in the condenser, from which it passes into the refrigerator at a very low temperature, quickly abstracting the heat from any fluid passed through the latter.

A boiler is connected with an analyser consisting of a series of plates arranged in the usual manner within a strong iron vessel. The analyser is connected with a rectifier, which is provided with a series of vertically arranged tubes surrounded by cold water, through which tubes the ammoniacal fluid passes to the condenser; or in an alternative arrangement the rectifier is provided with a series of vessels placed one above the other with a space between them, the vessels being so connected that a passage is formed from end to end thereof for a continuous stream of cold water. The condenser is either fitted with tubes and is practically similar in construction to the first arrangement of rectifier above mentioned, or it consists simply of a cylindrical or other suitably shaped iron vessel, of sufficient strength to resist the internal pressure of the gas, and immersed in cold water. From this condenser the condensed ammonia passes to a refrigerator, which may

be of any convenient form and construction. The liquid cooled in the refrigerator parts with the greater portion of its heat to the condensed ammonia, which is again vaporised, and in this form passes into an absorbing vessel which is kept cool by water, and which serves to maintain the required vacuum in the refrigerator. The ammoniacal solution passes from the absorber into a heating vessel, from which it is returned into the analyser. The latter may, however, on occasions be dispensed with, and the boiler connected directly with the rectifier.

In his 1870 invention further improvements are introduced, and the entire apparatus comprises a generator, an analyser, a rectifier, a liquefactor, a receiver, a refrigerator, an absorber, and a heater, an engine placed between the refrigerator and the absorber being sometimes, moreover, employed.

The first five of these vessels form what may be called the distillery part of the apparatus, and the main object of these improvements is likewise to ensure the more perfect elimination of liquid ammonia in an anhydrous condition, or practically so, from its aqueous solution, and in one continuous uninterrupted operation.

The analyser consists of a vessel fitted with a series of perforated cups or dishes, a dividing plate, an overflow pipe, and a dead plate or baffle to prevent the direct passage of the steam through the cylinder. The absorber comprises a series of pipes arranged together within a tank or cistern.

The ammoniacal gas eliminated from its solution in water by the action of the generator, analyser, and rectifier, passes onwards to the liquefactor or liquefier, wherein by its own pressure it is reduced to a liquid, and is collected in the receiver; the liquid ammonia so obtained being practically anhydrous. This anhydrous ammonia is then passed into the refrigerator, in which is placed a coil of pipe, any liquid passing through which will be cooled by the evaporation of the liquid ammonia surrounding it.

The refrigerator is connected through a stop-cock or valve to another coil contained or enclosed in an iron pipe, which coil extends to the absorber vessel, the latter being connected to the coil of piping contained in the refrigerator. The object of this second vessel and coil is to effect an interchange of temperature with the gas.

During its further onward passage to the absorber the ammoniacal gas comes in contact with the spent or exhaust liquor of the distilling apparatus in which it dissolves, yielding back the original quantity of the ammonia solution, to be used over again repeatedly without any appreciable loss or waste. This solution of ammonia is forced by

a pump into the top of the analyser, wherein the ammonia is separated from the water, and passes to the condenser to be liquefied, whilst, on the other hand, the exhausted liquor goes to the generator, and from thence into the temperature exchanger or heater, and on to the absorber.

The tension or elastic force possessed by the gas as it passes from the refrigerator to the absorber, especially when employed for cooling water, admits of its being utilised for driving the pumps of the apparatus, or for other purposes.

The operation of Reece's improved apparatus is briefly as follows :—

The charge of liquid ammonia (the ordinary commercial quality of a density of 26° Beaumé) is vaporised by the application of heat, and the mixed vapour of water and ammonia passed to the vessels called the analyser and the rectifier, wherein the bulk of the water is condensed at a comparatively elevated temperature, and is returned to the generator. The ammoniacal vapour or gas is then passed to the condenser, where it is treated in a substantially similar manner to that in Carré's apparatus, that is to say, it is caused to liquefy under the combined action of the condensation effected by the cooling water circulating round the condenser tubes, and of the pressure maintained in the generator. The liquid ammonia (in this case practically anhydrous) is then used in the refrigerator, and the vapour therefrom, whilst still under considerable tension, is admitted from the refrigerator to a cylinder fitted with a slide valve, and entry and exhaust ports, practically similar to those of a high-pressure steam engine, and is thus utilised to drive the force pump for returning the strong solution to the generator, after which it is passed into the absorber, where it meets, and is taken up by, the weak liquor from the generator, and the strong liquor so formed is forced back into the generator by means of a force pump as before described.

The temperature exchanger or economiser introduced by Mort in 1870 provides for the hot liquor on its way from the generator to the absorber giving up its heat to the cooler liquid from the absorber on its way to the generator, thereby saving the abstraction of so much heat from the generator, and admitting of the liquid in the absorber being kept at a lower temperature, which is of great importance to the economical working of the apparatus.

The invention which Harry Frank Stanley patented in 1875 comprises several important improvements upon the foregoing, the chief of which are as follows :—

In place of applying fire heat to the generator, as had been hitherto customary, a coil of steam pipes is employed for evaporating the

ammoniacal vapour. The advantages derived from this are that the pressure and temperature in the generator can be much more easily regulated, and, moreover, the ammonia separates from the water better at a low heat, and an even temperature is found to be most essential to the efficient working of the apparatus. The steam-heated evaporating pipes consist of a number of straight pipes connected together by bends, giving a very large heating surface, and when the exhaust steam from the engine is employed therein for heating purposes, a very great saving of fuel is effected.

The analyser is placed upon the generator so as to economise space and save the connections otherwise necessary. This analyser is formed preferably cylindrical, and is fitted with a series of dishes or trays having passages so arranged that the vapour impinges on the under sides thereof, and traverses the vessel without passing through the liquid. Each of the dishes or trays is provided with an overflow pipe which is raised above the level of the bottom of the tray, so as to keep some liquid in the dish, but always below the top of the vapour outlet. As the ammonia vapour is driven off from the solution of ammonia and water, by the heat of the vapour rising from the tray below, it passes through the vapour outlets into the rectifier without going through the liquor on the tray or trays above.

By this means a considerable saving of fuel is effected, as the ammonia when once separated from the water on each tray or plate is at once delivered to the rectifier. Otherwise, were this not so, water has such a strong affinity for ammonia, that the vapour which had been separated from the liquor on one plate would quickly become absorbed again by the liquor it had to pass through on the next plate.

The rectifier is placed on the condenser, the two forming in fact one vessel, and the same condensing water does duty for both, the latter passing in at the bottom of the condenser where the coldest water is wanted, and up the outside of the coil into the rectifier, from which it passes to the absorber. The ammoniacal gas or vapour passes from the analyser into the top of the coil in the rectifier, which coil is fitted at intervals with pockets to carry off the water resulting from the condensation of the vapour coming from the analyser, so that immediately any such condensation occurs the liquor passes at once out of the coil, and the ammoniacal vapour does not come in contact with the water after being separated from it. By providing these pockets with cocks or valves suitable adjustments of the apparatus can be effected.

The ammonia gas thus passes to the condenser in a practically anhydrous condition, which is absolutely essential to the economical working of the apparatus, and which would not otherwise be the case, as if the gas comes into contact with the water resulting from its condensation it would reabsorb a portion of it.

The condenser coil is contained in a cast or wrought iron cylinder, and to simplify the apparatus and to save space, the condenser is placed upon the receiver, the latter being a plain wrought or cast iron vessel serving, as before, to store the anhydrous ammonia before it goes into the cooler or refrigerator; it is fitted with a glass gauge, or a float gauge, to indicate the level of the liquid therein. When the latter is employed, revolving spindles or rods working vertically through stuffing boxes in the usual way are preferably used, as tending to minimise friction and prevent leakage.

The refrigerator or cooler is substantially similar to that employed in the former arrangements, but is fitted with a self-closing gauge in case of breakage.

The absorber is constructed of smaller pipes or tubes, so as to enable a greater number to be used than heretofore, and thus for a given content to secure a very much larger surface exposed to the action of the cold water which surrounds the tubes; the latter are preferably constructed of wrought iron.

Another saving of condensing water is effected by having a few of the top pipes above the upper extremity of the water cistern, and letting the warm water coming from the rectifier drip over the outside of the pipes. The heat due to the ammoniacal gas being absorbed by the weak liquor, which is given off from the inside, is sufficient to vaporise a portion of the water, and a large quantity of heat becomes latent in the vapour, producing a refrigerating effect.

The pump employed for drawing the strong solution of ammonia produced in the absorber, and forcing it through the coil of pipe in the heater into the analyser, against the pressure, is so constructed that there are the very least possible clearances, and that the whole, or practically the whole contents, are discharged at each stroke, thus preventing expansion of gas on the return stroke, tending to keep the suction valves closed. The pump cocks, valves, and gauges are provided with water containers, so that should any leakage of ammonia through the stuffing box occur, the water will absorb it, the latter being returned into the apparatus when it becomes thoroughly saturated. The stuffing box cock is constructed with a guard, and with an adjustable clamp screw, which holds the key to its seat, preventing leakage

from compression of the packing, and admitting of the stuffing box being repacked whilst the apparatus is at work.

To allow for the gradual weakening of the solution of ammonia, a small vessel or still is provided in connection with the generator, wherein the weak solution from the latter is evaporated off at a low temperature into the apparatus, where the least pressure exists.

In the invention patented by William Henry Beck, in 1886, some still further improvements in various details of construction are described, notably in the arrangement of the analyser and rectifier, and the absorber.

In the first-mentioned vessel a series of sheet iron or steel trays, with or without perforations, the edges whereof are drifted or set up so as to form short adjutages, are provided. Each alternate one of these trays has a central opening, and each intermediate tray an annular space left between its circumference and the enclosing case or cylinder. An inner sheet-metal casing is, moreover, provided in which the water-separating trays are secured, and which, together with such trays, can be easily removed and replaced in position; and the mouth of the vapour outlet pipe is sometimes surrounded by a finely perforated wire gauze chamber or guard.

The absorber is formed with a primary absorbing vessel, wherein the absorption of the ammonia gas is effected to an extent dependent upon the temperature of the ordinary cooling or condensing water, combined with a secondary absorbing vessel wherein a further absorption of the ammonia gas is effected by the cooling action of a current of cold brine, or of water, cooled to a temperature below that of the ordinary cooling or condensing water used in the primary absorber.

The weak liquor cooler, the liquid ammonia receiver, the condenser, and the rectifier are contained in a single open-topped tank provided with divisions or partitions so arranged as to ensure the passage of the cooling or condensing water successively through each of the compartments.

Frederick Noel Mackay and Adolph Gothard Christiansen obtained a patent for improvements in ammonia absorption machines in 1887, the main features of which that are claimed as novel being as follows, viz. :—

The separation of the ammoniacal gas from the liquor in which it is absorbed, by boiling the liquor in stages within the same boiler.

An analyser consisting of a chamber containing superimposed spirally corrugated plates having perforations or openings.

The combination within one chamber of an ammoniacal liquor boiler and analyser.

A rectifier consisting of such an arrangement of a coil or coils that the gas will take an upward direction, and the liquid a downward direction.

A condenser wherein the coils are so connected that the gaseous ammonia passes from coil to coil in an upward direction, whilst the liquid ammonia flows in a downward direction.

A multiple coil condenser so constructed that it has but one single through way.

A rectifier and condenser consisting of chambers containing coils, all the joints whereof are situated on the exterior.

An auxiliary cooler composed of a chamber fitted with a coil and regulator, and suitable connections.

A vaporiser and refrigerator wherein the brine flows through a chamber, whilst the liquid ammonia expands through small perforations or apertures into tubes contained in this chamber.

An absorber constructed with a concentric corrugated chamber.

Ammonia pumps provided with a chamber through which ammonia liquor from the absorber passes.

An arrangement whereby ammoniacal liquor from the absorber is caused to cool ammoniacal liquor from the boiler.

In Edward Henry Tompkins' patent, which was granted in the latter part of 1887, for improvements in refrigerating apparatus of the kind or class for which previous letters patent were granted to Rees Reece and William Henry Beck, the chief novel points claimed are:—

The placing of the generator within the boiler so as to secure the full efficiency of the heat given off by the steam generated therein.

The combination and connection with the main gas pipe from the generator of a vessel doing the triple duty of heater, rectifier, and analyser; which vessel consists of an iron tank with an arrangement of tubes, and a sealed joint or joints at the base through which the gas rises.

An improved form of condenser, consisting of an ordinary condenser of the multitubular pattern, wherein the tubes are passed through a tube plate and expanded in the usual manner, but having in addition horizontal partition plates of metal at the alternate ends of the tubes, whereby the ammonia is caused to travel backwards and forwards along the alternate layers or sets of tubes, and thereby to receive the full benefit of the cold of the condensing water. By the removal of the end covers, moreover, each layer or set of tubes is rendered readily accessible for cleaning or repairs.

A cooler or refrigerator comprising a system of horizontal tubes placed in a large tank, within which latter a solution of chloride of calcium is caused to circulate so as to secure an equable temperature throughout the entire length of the tank.

An absorber, wherein provision is made for intimately mixing the ammonia gas from the refrigerator or cooler with ammonia liquor, cooled, firstly, by passing it through a small cooler, and secondly by bringing it in contact with a series of tubes through which water is made to circulate, thereby effecting a considerable gain in the working of the apparatus.

An ammonia pump provided with a stuffing box wherein is inserted a hollow steel or iron ring of suitable dimensions, to which ring is connected a pipe leading to a receiver having a glass gauge to show the height or quantity of liquor ammonia which has escaped past the first series of packing, and is contained therein. From this receiver a pipe fitted with suitable stop-cocks or valves leads to a small hand-force pump or compressor of the ordinary type, so that by opening and closing these stop-cocks the escaped liquor can be withdrawn into the pump or compressor, or forced back into the generator, as may be desired.

The provision of means whereby the ammonia liquor from the absorber is passed through a coil contained in the compound vessel doing triple duty as heater, rectifier, and analyser, and consequently enters the generator at a high temperature, and the temperature of the ammonia gas on its way to the condenser is likewise reduced. The condensation from this ammonia gas which occurs in the rectifier and analyser is conveyed back to the generator by gravitation; the above-mentioned compound or triple vessel being situated above the level of the generator, and the pressure in both vessels being equal.

A small cooler wherein the weak liquor ammonia coming from the generator in its heated condition is reduced to a state of comparative coolness by contact with tubes cooled by a circulation of cold water, to which water may be added, if required, waste ice to increase its cooling capacity. The advantage claimed for thus reducing the temperature of the weak ammonia solution is that its power of absorbing the ammonia gas from the cooler or refrigerator is thereby greatly increased.

The patent granted to Edmund Lionel Pontifex in 1887, subsequently to both those just mentioned, for improvements in cooling and refrigerating machines of the class described in the specification of

former letters patent granted to H. F. Stanley in 1875, lays claim to the following:—

The method of mounting the condenser coils upon brackets projecting inwards from the side of the cistern, and retaining them in position by means of uprights extending vertically from these brackets; some of which uprights are extended above the tops of the condenser coils for the purpose of supporting the rectifier coil, and also for carrying a vertically arranged cylinder occupying a space in the centre of the rectifier coil, and extending to above the level of the overflow from the cistern. The object of this cylinder is to ensure that the cooling water, that rises up through the cistern, should flow only through the annular space or clearance situated between the exterior surface of the cylinder and the inner surface of the cistern, and thus cause it to act in a more efficient manner to cool the rectifier coil which is contained in this space or clearance.

An arrangement for ensuring a uniform action taking place in all the concentric coils of the condenser, and causing the liquid coming therefrom to be of the same temperature, consisting in spacing the outer coils vertically further apart than the inner coils, so that the increased diameter of the outer coils is compensated for by the greater number of the inner coils.

To provide for the more perfect regulation of the admission of the anhydrous ammonia liquid to the cooler, which requires very fine or minute adjustment, a stop-cock is provided with a plug through which, in addition to the way or passage which is usually formed therein, there are, at the sides of this way or passage, other narrow passages which, when the stop-cock is partially turned on, allow of a small and easily regulated quantity of liquid or fluid being permitted to pass; whilst, on the other hand, it likewise admits of a large volume of the liquid being allowed to pass quickly, whenever the cock is turned full open, as is sometimes necessary for the purpose of clearing the small passages by blowing out any obstructions which may lodge therein and tend to choke them.

The ensurance of a more effective absorption of the gas, by so arranging the absorber that the weak ammonia liquor or solution is made to fall in the form of a shower on to the surface of a tray, which latter is provided with small holes or perforations arranged in concentric circles. Through these holes the weak ammonia liquor percolates or drops down on to the tops of the coils of cooling pipes, trickling slowly from coil to coil until it reaches the bottom of the absorber, from which latter it is sucked by the ammonia pump through

a pipe fitted at its inlet end or extremity with a perforated strainer or guard, in order to prevent the ammonia pump suction pipe from becoming accidentally choked or stopped up by any foreign bodies.

In order to enable the interior of any of the coils of pipe in the absorber being readily cleared of any deposit, suitable means are provided for admitting of a pump cylinder being easily attached to the outlet of each of the coils. This cylinder is fitted with a piston which, by means of a piston rod extending therefrom, can be jerked

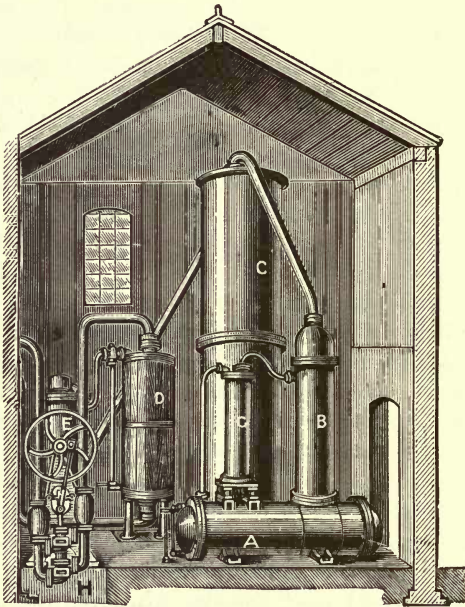

Fig. 107. —Pontifex-Wood Improved Continuous-Acting Ammonia Absorption Machine.

or moved suddenly and violently to and fro, whilst the cooling water is flowing through the coil. The shock thus caused liberates any scale that may have become deposited inside the coil, and this scale is carried off by the flow of the condensing or cooling water.

The Pontifex ammonia absorption machine has been further improved by Wood, and the Pontifex-Wood apparatus, as at present constructed, is probably as near to perfection as can be attained in machines of this class.

Fig. 107 is a perspective view, showing the elevation and general arrangement of a machine of the Pontifex and Wood type, which comprises a generator, a separator, a condenser, a refrigerator, an absorber, and an economiser, all of which are fitted with the latest improvements.

Referring to the illustration, A is the generator, B is the separator, C is the condenser, D is the refrigerator, E is the absorber, and G is the economiser. H are the ammonia pumps, the construction of which will be more clearly understood from the enlarged views, Figs. 108 and 109.

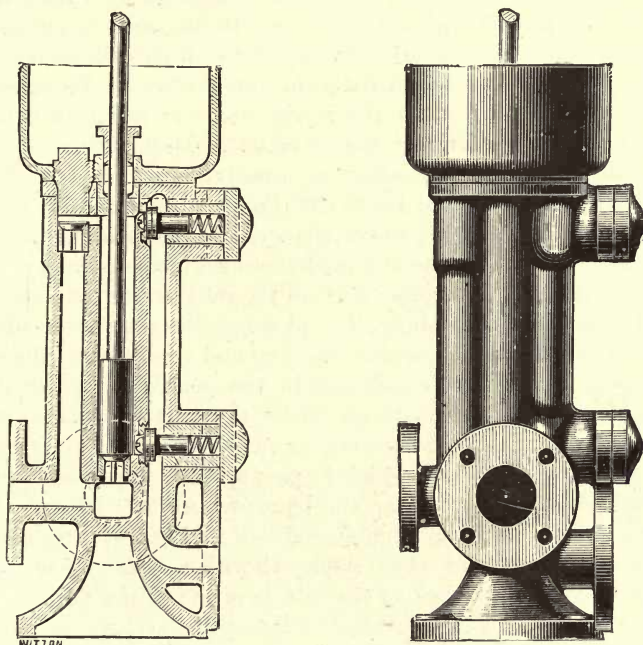

* Figs. 108 and 109.—Pontifex-Wood Improved Ammonia Pump.
Elevation and Vertical Central Section.

The generator A consists of a horizontal cast-iron cylindrical vessel, containing a coil of steam pipe adapted to be heated by direct or live steam from the ordinary steam boilers, and into which the charge of commercial ammonia is inserted.

The separator B, which is connected to the top of the generator by suitable flanges, and arranged vertically, and at right angles to the latter, is so constructed that any aqueous vapour that rises with the vaporised or gasified ammonia from the generator will be arrested or

trapped by a suitable arrangement of baffles or checks, and is returned into the generator; the practically anhydrous ammonia passing through a pipe from the top of the separator to the condenser c.

In the condenser c, which consists of a number of coils of pipes inclosed in a wrought-iron vertical cylinder which is constantly kept full of cold water in circulation, the anhydrous ammoniacal gas or vapour is condensed and liquefied by the pressure caused by its own accumulation.

The liquid ammonia, which leaves the condenser at a temperature of between 70° and 80° Fahr., next passes into the cooler or refrigerator d, which is a vertical cast-iron vessel fitted with coils of wrought-iron pipes, through which a circulation of water or brine is kept running. In this cooler or refrigerator the liquid ammonia instantly expands, and again takes the form of gas or vapour. During this expansion its sensible heat becoming latent, as already stated, its temperature is reduced instantly to from 10° to 20° Fahr., or considerably lower if required, and the water or, where employed for ice-making, the brine is reduced or cooled down to any predetermined temperature.

After performing its cooling office in the refrigerator d the ammonia gas or vapour is led through another pipe into the absorber e, wherein it comes into contact with, and is taken up and absorbed by, the water from which it was first eliminated in the generator a, the strong solution thus formed being drawn off by the ammonia pumps h and forced back through the economiser or heater g (wherein its temperature is raised by the water which is passing from the generator into the absorber) into the generator a to be re-evaporated.

The improved ammonia pumps, as shown in Fig. 107, are mounted in A-shaped frames, and when employed with a brine circulation, a brine pump is also attached to the outside of one of the A frames, and is driven by means of a disc crank fixed upon the shaft carrying the eccentrics for working the ammonia pumps.

One of the ammonia pump cylinders is shown in side elevation and vertical central section in the enlarged views, Figs. 108 and 109. As will be clearly seen from the sectional view, Fig. 109, the pump is of the piston type and double-acting.

A great advantage in having two ammonia pumps is that they can be so arranged that, if necessary, one of them can be shut off for repairs or overhauling, whilst the other is continued in work.

The method of working the Pontifex-Wood improved ammonia absorption machine is as follows:—

All connections being properly made, and the generator filled or

charged with the ordinary ammoniacal liquor of commerce, up to the proper level, as indicated by the gauge attached thereto, a little steam is admitted to the coil of pipes inside the generator, so as to raise just sufficient pressure of gas or vapour to expel all the air from the apparatus through an escape valve provided for that purpose in the absorber.

As soon as all the air is thus expelled, the full pressure of steam is turned on to the heating coils in the generator, and the ammonia in the solution, being extremely volatile, is instantly driven off in the form of gas or vapour, and passes up through the separator, where any aqueous vapour is arrested, and returned to the top of the condenser; the aqueous portion of the ammoniacal solution remaining behind in the generator.

The condensing water is admitted at the bottom of the condenser and is taken off at the top, the ammoniacal gas or vapour taking the opposite course, and passing downwards through the coil of pipe therein, the upper portion of which coil is provided at intervals with traps or pockets, and is known as the rectifier. During its passage through this coil the gas, or vapour, is reduced in temperature by the condensing water, and any watery particles that may have escaped the separator, and been carried over with the ammonia, are caught in the above-mentioned traps or pockets, and are immediately passed out of the coil and returned into the separator, through the connection shown in the drawing. After passing the lowermost trap or pocket the ammoniacal gas or vapour is quite dry or anhydrous, and it is the practically perfect reduction thereof to this condition that constitutes the chief advantage of the Pontifex-Wood improved machine.

The dry or anhydrous ammoniacal gas or vapour now continues to descend the coil in the condenser, until, by reason of its accumulation, it reaches a pressure at which it becomes liquefiable, the liquefaction being greatly forwarded by the reduction of temperature effected in the condenser by the constant circulation of the cooling water. The apparatus is so constructed and regulated that, as the gas or vapour becomes liquefied, the product of liquid anhydrous ammonia passes into the refrigerator, wherein it vaporises at the ordinary atmospheric pressure at a temperature as low as -28° Fahr., and at the moment it thus changes its form it absorbs and renders latent a very large amount of heat, as has been already mentioned.

The water or other liquid to be cooled is passed direct through the coil arranged in the refrigerator; or, where ice-making is carried out, a strong solution of chloride of calcium or brine is passed through

it, cooled to the requisite low temperature, and pumped into the ice-making or freezing tanks.

The ammonia, which has now again assumed a gaseous form, passes from the top of the cooler or refrigerator into the absorber, which latter is connected to the bottom of the generator, through a suitable pipe, the pressure in the latter forcing a constant stream of the water left in it at starting into the absorber, where this weak solution greedily absorbs or takes up the gas coming from the refrigerator, and the strong solution thus formed, which is similar to that first placed in the generator, is drawn off by the ammonia pumps.

The strong rich solution is then forced through a coil of pipe in the economiser or heater into the top of the separator, wherein it passes down through a succession of trays, which latter are heated by the hot vapour or gas ascending from the generator, and the ammonia is once more separated from the water in which it is dissolved, the solution gradually becoming weaker, until it finally falls back into the generator almost entirely exhausted of ammonia.

As in Carré's apparatus, the complete process forms, it will be seen, a continuous closed cycle, the changes from liquid to gas and *vice versa* being constantly repeated.

Theoretically the only outlay for working the machine, outside the small amount of oil required for lubricating the moving parts and the labour, is that entailed for the coal or other fuel consumed in raising steam for heating purposes, where exhaust or waste steam is not employed, and for supplying the small steam engine requisite to drive the ammonia pumps; in cases, however, where water has to be paid for, there is an additional outlay for the water that is used for condensing and other purposes. The boiler power required, where direct or live steam is used, varies from 2 H.P. in the smaller machines, which are capable of performing work equal to the reduction of 225 gals. of water 10°, or of 60,000 cub. ft. of air 20° Fahr. per hour, or of an ice equivalent melted per twenty-four hours of 1½ tons; up to 15 H.P. in the larger sizes adapted to so treat 8,000 gals. of water, or 1,900,000 cub. ft. of air, or of an ice equivalent in tons melted per twenty-four hours of 50 tons. In like manner the indicated horse-power that is necessary for driving the ammonia pumps will run from one, in the small machines, up to six in the larger sizes; and the amount of condensing water at 50° Fahr. from 100 to 3,000 gals. per hour.

In practice a certain amount of the ammonia is always unavoidably lost by leakage, even under the most favourable circumstances. The

amount of ammonia that thus goes to waste and has to be replaced depends chiefly upon the care taken in packing the ammonia pumps, but under average conditions it usually varies from 240 to 400 lbs. per annum. The price of the ordinary commercial liquor ammonia used in the machine is from 3d. to 4d. per lb. In some exceptional cases, however, machines have run in a satisfactory manner for two or three years without any additions of ammonia having been made.

Other refrigerating machines acting on the above principle, of which mention may be made, are those of Hill, Seeley, and another one of French origin.

A number of British patents have been obtained by Frederick Barker Hill, both singly and in combination with others, for improvements in ice-making and refrigerating machinery. No. 3,427 of 1876, Nishigawa and Hill; No. 6,808 of 1885, Hill and Gorman; and No. 15,914 of 1886, Hill and Gorman, claim certain improvements in absorption machines, the latter patent comprising mainly improved means for heating the ammonia boiler and for the formation of cold stores for refrigerating purposes. Hill, No. 13,487 of 1887, describes a refrigerating machine with mercurial pump, wherein mercury is employed for drawing air or other gas or vapour into and discharging it from one or more chambers. It is stated that the mercury acts as a seal to close the aperture of the suction pipe, and that, consequently, the use of a suction valve can be dispensed with. This pump may be adapted for use with an apparatus such as described in the previously mentioned patent.

No. 17,071 of 1888, Hill and Sinclair, contains a description of a refrigerator or ice-making machine mounted upon road or travelling wheels, and provided with suitable means whereby motion may be transmitted to its driving shaft from one of the wheels during transport.

No. 20,811 of 1889, Hill and Sinclair, contains certain improvements in the absorption machine described in No. 15,914 of 1886. The ammonia boiler or still is formed in this case of two horizontal tubes connected by suitable pipes which extend longitudinally within the tubes. The horizontal parts of the pipes are perforated at their upper sides to ensure uniformity in the action of the apparatus. In combination with the refrigerating apparatus are employed two slabs or tables formed of metal or other suitable material of good thermal conductivity, beneath which circulates brine or other non-congealable liquid for conveying the cold from the refrigerating tubes or chambers to the slabs or tables. These cold slabs or tables are adapted for facili-

tating and expediting the manufacture of chocolate, confectionery, pastry, and other substances which are formed in moulds, and which can be manipulated upon the slabs or tables.

Hill, No. 16,253 of 1889, describes an improved refrigerating and ice-making machine, adapted to work on the intermittent ammonia-absorption process. The main features of the invention consist in the production of cold by this method, wherein impoverished ammoniacal liquor from the ammonia boiler is caused to pass into one or more supplementary or auxiliary absorbers, in which the ammoniacal gas is subsequently absorbed, and from which the liquor, together with the gas absorbed thereby, is then returned to the ammonia boiler.

In ammonia-absorption refrigerating and ice-making machines as constructed before the date of this invention, it was necessary, after the distillation of the ammonia, to reduce the temperature of the liquid in the boiler until the pressure became sufficiently diminished to permit the vaporisation of the liquid ammonia in the refrigerator, and until the liquid in the boiler was sufficiently cool to permit the absorption of the ammoniacal gas thereby. This cooling of the liquid necessarily occupied a considerable space of time. Besides, in many of these refrigerating and ice-making machines the absorption of the ammoniacal gas took place only at the surface of the liquid in the boiler, and was necessarily a slow process, the liquid being of higher temperature at the surface than at any other part thereof, and having its temperature raised at the surface by the condensation of the gas.

The inventor claims to have discovered that, by employing one or more separate or auxiliary absorbers, which can be put in communication with the boiler, the cooler or condenser, and the refrigerator as required, and in which the ammoniacal gas can ascend through a body of liquid, he can very rapidly diminish the pressure in the ammonia boiler by absorbing the gas from the boiler, the rectifier, and the condenser in the absorber or absorbers; and is enabled to effect the absorption of the ammoniacal gas from the refrigerator, either in the supplementary or auxiliary absorber or absorbers or in the boiler, immediately or very soon after the distillation, thus greatly expediting the production of cold by the machine.

Fig. 110 is a front view partly in section, and Fig. 111 is an end view of Hill's refrigerating apparatus provided with a supplementary or auxiliary absorber.

A indicates the ammonia boiler, B the separator or rectifier, C the cooler or condenser, and D the refrigerator. E is the supplementary or auxiliary absorber, which is connected with the boiler A, the condenser

C, and the refrigerator D by pipes F, F¹, F², F³, fitted with stop-cocks or valves G, G¹, G², G³. By the manipulation of these cocks as may be required, the impoverished ammoniacal liquor from the boiler may be introduced into the absorber E after the distillation of the ammonia, and the liquid charged with gas by absorption may be caused to return from the absorber to the boiler. Thus when the liquid anhydrous ammonia has been collected in the refrigerator D, the cocks G², G³, are closed and the cocks G, G¹ partly opened, so as to admit of the weak or impoverished solution from the boiler A, or a sufficient portion of it, being forced into the absorber E; the cock or valve G¹ is then closed,

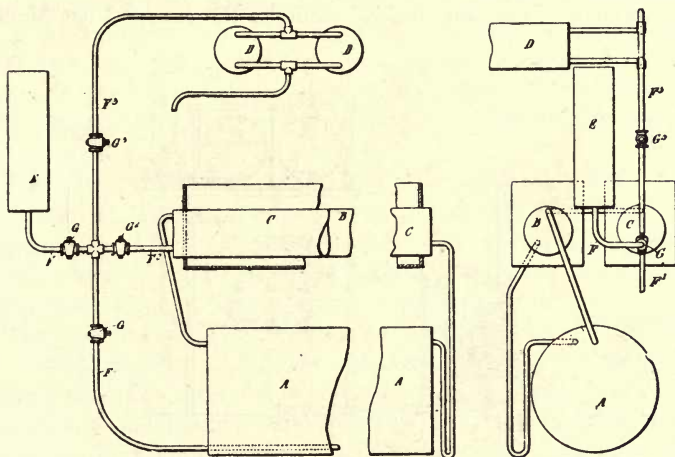

Figs. 110 and 111.—Hill's Ammonia Absorption Machine with Supplementary or Auxiliary Absorber. Diagrams showing Front and End Views.

and the cock G² is opened to rapidly relieve the pressure in the condenser, rectifier, and boiler, by allowing the gas therefrom to become absorbed by the weak solution in the absorber E. As soon as the solution in the boiler is sufficiently cooled to permit reabsorption of the gas thereby, the boiler is placed in communication with the refrigerator by opening the cocks or valves G¹, G³. The ammonia solution from the absorber E will be returned by gravity or in any other convenient manner into the ammonia boiler A, through the cocks G, G¹, when required.

Instead of placing the refrigerator D in communication with the boiler A, it may be so connected with the supplementary or auxiliary

absorber E, thereby permitting the vaporisation of liquid ammonia in the refrigerator, and the absorption of the ammoniacal gas by the impoverished ammoniacal liquor previously introduced into the absorber E from the ammonia boiler. While the vaporisation of the ammonia in the refrigerator is thus proceeding, the weak solution in the ammonia boiler may be cooled, after which the refrigerator may be put into communication with the ammonia boiler.

In Fig. 112 is shown a complete machine constructed on the foregoing principle. L is a coil boiler for heating the solution in the ammonia boiler A, with which the coil boiler is connected through the medium of a separator M.

The type of absorption machine made by the Henry Vogt Machine

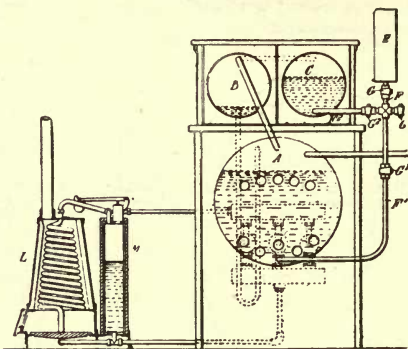

Fig. 112.—Hill's Ammonia Absorption Machine, with Supplementary or Auxiliary Absorber. Diagrammatical View of Complete Machine.

Co., of Louisville, Ky., U.S.A., has no round coils and bent pipes. The generator operates on the fractional distillation principle, and is claimed to produce practically anhydrous ammonia. It consists of a main casting divided into four compartments communicating the one with the other, and four horizontal pipes connected to the main casting, which contain the steam heating coils. The highest compartment of the main casting is connected to a stand-pipe containing an analyser and rectifying coil by which the gas is dried before it leaves the still. The strong liquor is passed in at the top of the stand-pipe, and descending through the rectifying coils and the analyser reaches the upper compartment of the main casting, from which it flows over the steam coil in the horizontal pipes, passing from one to the other until

the lowermost compartment is reached. The gas that is generated is delivered through the aperture in each compartment to the stand-pipes, where it deposits its moisture, and the dried gas goes on to the condenser.

The heat exchanger or economiser consists of an arrangement of straight concentric tubes, the outermost of which are connected at their alternate extremities by H-shaped pieces, and the inner ones being coupled together by external bends also acting as glands to the jointing. The strong ammonia liquor enters the heat exchanger at the bottom on its passage to the still or generator, and is delivered out at the top. The weak liquor from the still or generator on the other hand enters the heat exchanger at the top, and leaves it at the bottom.

A double-acting horizontal fly-wheel pattern pump, running at a speed of twenty-five revolutions per minute, is employed, the special feature of which is the construction of the ammonia stuffing box with a surrounding water chamber, which acts as a lubricator to the piston rod.

The absorber is constructed in the form of an upright tubular boiler open at the top, the tubes being uniformly distributed, and so arranged that they can be cleaned whilst the machine is running. The cooling water is admitted at the bottom, and passes out at the top, an automatic regulator controlling or governing the flow.

The type of absorption machine made by the Ice and Cold Machine Co., of St Louis, Mo., U.S.A., is a modification of the Carré apparatus by Mr Ball. The generator is constructed of steel and is of a vertical cylindrical form, having a removable top head, steam heated, and with drying trays or pans arranged in the gas dome. An open-air or a submerged type of condenser is employed in accordance with the water supply. The heat exchanger or equaliser is a cylinder fitted with removable heads containing tubes. From the shell of this heat exchanger the poor liquor passes to the coils of the poor liquor cooler, which is also either of the submerged or open-air surface evaporative type, and thence to the absorber.

The gas liquefied in the condenser tubes passes through the expansion valves to the expansion or evaporating coils in the freezing tank, and it returns from thence to the absorber.

This latter apparatus is a cylindrical-shaped vessel fitted with vertical tubes, up through which the water passes, removing the heat from the ammonia.

The ammonia is raised by two single-acting vertical pumps driven by a vertical steam engine, to which they are directly coupled. These

pumps lift the enriched ammonia from the absorber through the exchanger tubes into the top of the generator, and thus complete the cycle.

To dry the gas and separate any moisture therefrom the air-blast is maintained at a temperature of 14° below zero Fahr., and the temperature of the ice-making box or tank is from zero to 2° Fahr.

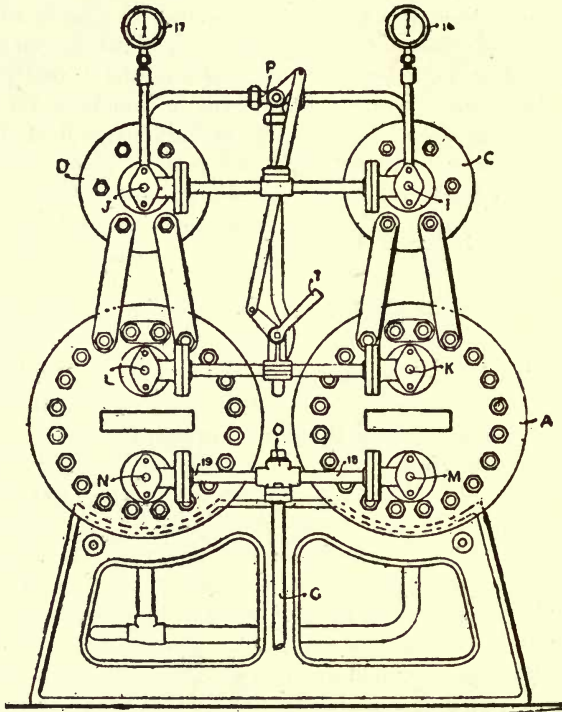

Fig. 113.—Tyler & Ellis' (Cracknell's Patent) Ammonia Absorption Machine. Front View.

Fig. 113 is a front view, Fig. 114 is a side view, and Fig. 115 is a vertical longitudinal central section through either side of Fig. 113, showing Cracknell's patent ammonia absorption machine, formerly made by the Tyler & Ellis Mfg. Co., Ltd., subsequently by Ransome & Rapier, Ipswich, and known as the "Simplex." The machine consists essentially of two vessels (A and B), one of which vessels (say B) contains strong anhydrous ammonia liquor, and is heated by a steam coil, whilst the

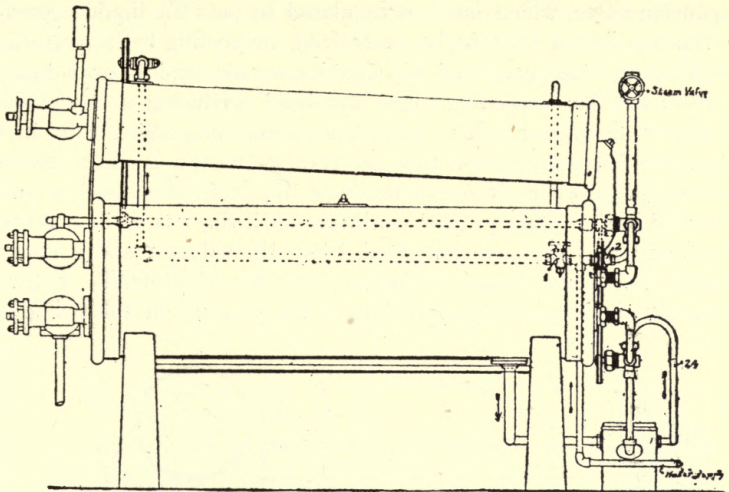

Fig. 114.—Tyler & Ellis' (Cracknell's Patent) Ammonia Absorption Machine. Side Elevation.

other vessel A is filled with the spent liquor from the last operation, and is cooled by a water coil. Ammonia is given off in B under considerable pressure, and passes through the valve to the condenser, where, becoming cool, it condenses or liquefies, and passes to the expansion valve as liquid anhydrous ammonia. After getting by the

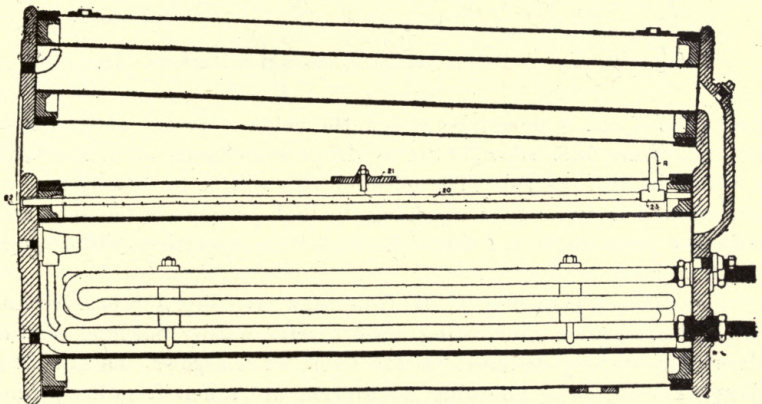

Fig. 115.—Tyler & Ellis' (Cracknell's Patent) Ammonia Absorption Machine. Vertical Longitudinal Central Section.

expansion valve, which latter is regulated to pass the liquid according to the amount of heat to be abstracted, or cooling to be performed, the pressure disappears, and the liquid ammonia rapidly evaporates as it traverses the succeeding pipes and coils, producing a large volume of gas of an intense cold. After traversing the cooling coils in the evaporator or refrigerator the gas returns to the machine through another valve, where it meets the weak liquor in the vessel A, and is absorbed by it. This process continues until the charge in B becomes spent, and that in A concentrated, when the valves I and N must be closed, the valves L and K opened, the reversing handle T turned towards D, and upon the equalising of the pressure on the two gauges

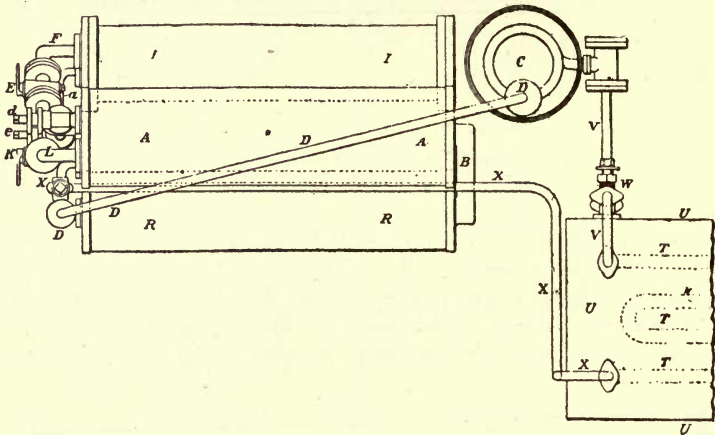

Fig. 116.—Lyon's Patent Ammonia Absorption Machine. Plan.

the valves L and K should be closed, the valve J opened, and, as soon as the pressure falls below 30 lbs. on the pressure gauge on A, the valve M should be also opened. The effect of this will be to exactly reverse the order of things, A then becoming the high pressure or hot side, and B the low pressure or cool side. Each of these operations will average about an hour.

Fig. 116 is a plan, Fig. 117 is front view, and Fig. 118 is a vertical longitudinal section illustrating a small refrigerating machine, on the absorption system, designed by Mr Lyon, of Glasgow. The illustrations, as well as the following description, are taken from his patent specification.

G is the generator, and A is the absorber, both of which are hori-

zontally placed cylindrical vessels, the absorber being located at a higher level than the generator. Heat is applied in the generator G, through a pipe s, through which steam is passed, or an electric heater or other known heating appliance may be used; and the vessel is encased in a shell packed with a material H which is a bad conductor of heat. The upper part of the generator G is connected by a pipe B to the lower part of a vessel R, termed a rectifier, which is kept at

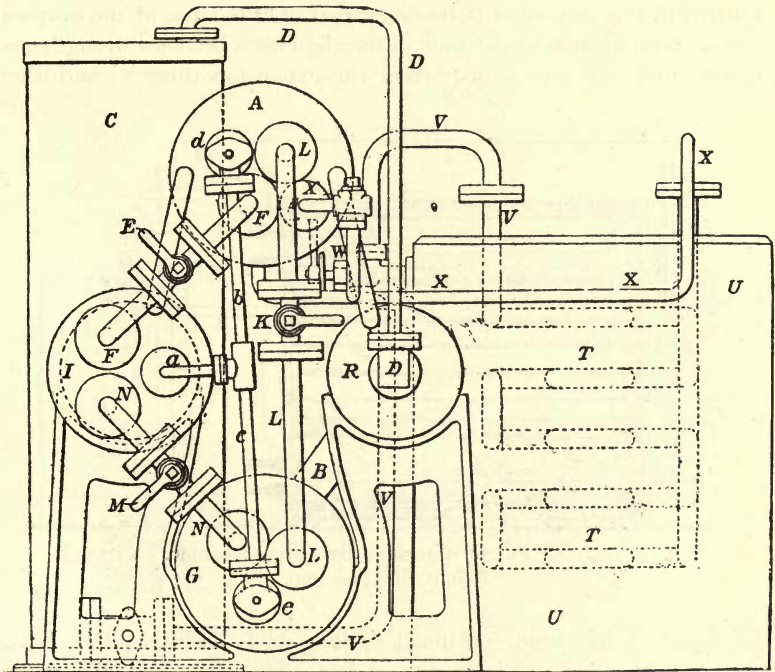

Fig. 117.—Lyon's Patent Ammonia Absorption Machine. Front Elevation.

a moderate temperature by a water jacket J, and in which ammonia vapour entering it from the generator G separates from traces of water which return to the generator. From the rectifier R the ammonia vapour passes through a pipe D to a worm or other condenser C, in which it is acted on by cold water so as to become cooled and liquefied.

The ammonia thus condensed and liquefied is employed in the ordinary way so as by its expansion in tubing T, indicated by dotted lines, immersed in brine in a tank U, to produce refrigeration, the

ammonia proceeding from the condenser *c* by a pipe *v*, having on it a regulating or expansion valve *w* to the expansion tubing *t*. From the expansion tubing the ammonia vapour passes by a pipe *x* into the absorber *A*, which is provided with an internal pipe coil *y*, and with an external jacket *z*, through which cold water is passed.

On starting the machine the absorber *A* will be partly filled with water or with a weak solution of ammonia, there being then in the generator *G* a strong solution of ammonia. During the operation the solution in the generator *G* becomes weakened because of the evaporation of the ammonia, whilst that in the absorber *A* becomes strengthened by absorbing ammonia vapour from the expansion tubes *t*; and when

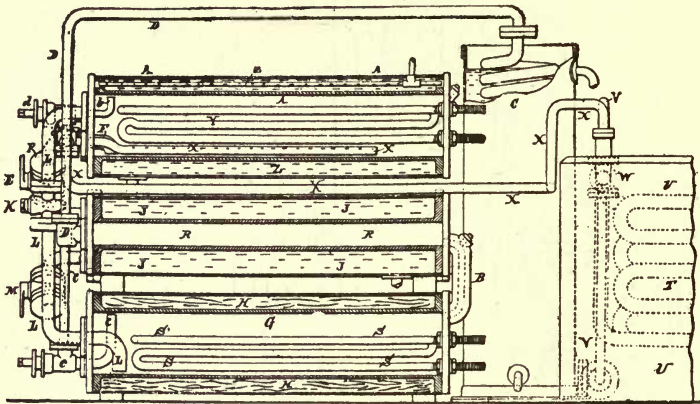

Fig. 118.—Lyon's Patent Ammonia Absorption Machine. Vertical Longitudinal Section.

the operation has been continued as long as is desirable, the strong solution in the absorber is run through a stop-cock *e* and pipe *f* into an intermediate vessel *i*. Then there is opened a stop-cock *k* on a pipe *l*, which extends from the absorber *A* down to the lower part of the generator *G*, whereupon, owing to the excess of the pressure in the generator over that in the absorber, the weak solution in the former is transferred to the latter. Finally a stop-cock *m* in a pipe *n*, connecting the intermediate vessel *i* with the generator, is opened, and the strong solution is run into the generator ready for a fresh operation.

For the purpose of equalising the pressure, the intermediate vessel *i* has connected to it a pipe *a*, with branches *b*, *c*, connected to the absorber *A* and to the generator *G*, the branches having stop-valves *d*, *e*.

Thus when the solution is being transferred from the absorber A to the intermediate vessel I the upper valve *d* is opened, the lower one *e* being closed, and when the solution is being transferred from the intermediate vessel I to the generator C, the upper valve *d* is closed, and the lower one *e* opened.

An ammonia absorption machine designed by Mr C. Senssenbrenner, a German inventor, and shown in Fig. 119, has an evaporator *a* communicating with the condenser *d* through an opening *e*. The condenser

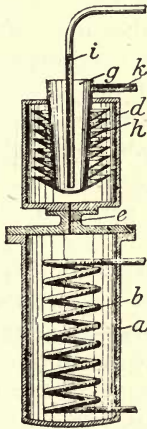

Fig. 119. — Senssenbrenner Patent Ammonia Absorption Machine.

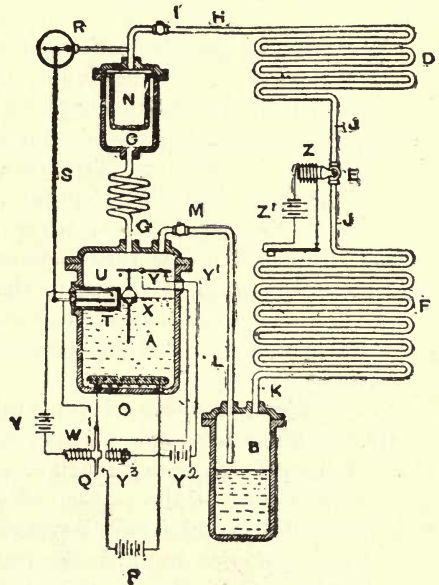

Fig. 120. — Diagram illustrating Coleman's Electrically-heated Absorption Machine.

is fitted with a cooling receptacle *g*, which has on its outer surface upwardly inclined ribs *h* for catching the ammonia which is liquefied. During condensation, water is admitted to the receptacle *g* by an inlet pipe *i*, and is led away by the outlet *k*, but, when the receptacle *a* is cooled by the passage of the water through the coil *b* and the pipe *i* is removed, water placed in the receptacle *g* is frozen by the evaporation of the ammonia. The receptacle *a* may be heated by steam or fuel.

Fig. 120 is a diagram illustrating a patent automatic electrically

heated absorption machine lately designed by Mr C. J. Coleman, of Chicago, U.S. In the diagram the apparatus is shown partly in vertical central section, and A represents a combined absorption and generating chamber; B an auxiliary absorption chamber; C the rectifier or water separator; D the storage or condensing coils or chamber in which the ammonia gas collects in a liquid or highly condensed state; E the automatic expansion valve or cock; F the expansion chamber, or coils, wherein the condensed ammonia gas from the storage chamber is allowed to expand so as to effect the cooling step or operation of the system.

As shown, the generator A is connected by means of a pipe G with the water separator or rectifier C, and this latter is in its turn connected by a pipe H with the condensing or storage chamber D, a check valve I being provided in this pipe connection to prevent any backflow into the rectifier and generator. The condensing chamber D is connected to the expansion or cooling chamber F by a pipe J, in which latter is arranged the expansion valve or cock E, and the expansion or cooling chamber is in its turn connected to the auxiliary absorption chamber B, by means of a pipe K, the auxiliary absorption chamber being connected to the main generator by a pipe L, fitted with a check valve M, to prevent any backflow from the generator into the former.

The rectifying chamber C is provided with a partition or diaphragm N, which is constructed of some material of a porous nature that will allow of the passage there-through of a gaseous body such as ammonia gas, but will prevent the passage of water or aqueous vapour. For this purpose the inventor finds unglazed and highly vitrified porcelain to be a good material, and a similar material to that employed in the manufacture of the ordinary porous battery cups that has been treated with some antihygroscopic material, such as paraffin, is likewise found to be suitable for the purpose. The cup or pot-shaped form shown in the drawing is found to be preferable, as affording the maximum amount of working surface, in combination with cheapness and simplicity of construction.

Electricity is employed for heating purposes, and O represents an electric heater, which is arranged within the generator A, so as to raise the temperature of the latter to the desired point. The operating circuit of this electrical heating apparatus includes, in addition to a battery, or some other source of electrical energy P, a switch mechanism Q, which is adapted to open and close the circuit, and which is so pivoted that it will have more or less friction on its

pivotal bearing, and thus will have a tendency to remain in the position to which it may be set or moved, until such time as it is positively moved from such position; R is a pressure gauge or motor, located in the pipe connection H, leading from the rectifier C to the storage tank or coil D, and the duty of which is to indicate the pressure within this coil or tank, and also to impart movement in unison with the pressure in this latter to a connecting rod or link S, which latter is in operative connection with a pivoted thermostat T of a bimetallic formation. These connections are so arranged that with the variations of pressure in the storage tank or coil D, the thermostat T will be correspondingly moved towards or away from the contact point V. This operating circuit, which is controlled by the thermostat, in addition to a battery or other source of electrical energy V, also includes an operating electro-magnet W, by which the switch mechanism Q is worked, so as to break or open the circuit of the heating apparatus O.

X is a float arranged in the interior of the generator A, which float is connected with a pivoted bimetallic thermostat Y in such a manner that the final movement of the float in an upward direction will move the thermostat Y towards the contact point Y¹, and will thus complete or close the circuit. In this circuit is also included a battery Y², and an operating electro-magnet Y³, by which the switch mechanism Q is worked to close or complete the circuit of the heating apparatus. The electro-magnet Z is adapted to open the expansion valve or cock E, and the operating electrical circuit in this magnet, in addition to a battery or other source of electrical energy Z¹, also includes a thermostat Z², which is within the influence of the expansion or cooling chamber F of the system, and which is adapted to maintain the temperature within the expansion chamber constant.

In Fig. 121 is shown diagrammatically the general arrangement of a leading type of modern American absorption machine. The construction of this apparatus will be seen from the particulars given upon the drawing, and the operation of a large modern plant will be clearly understood from the diagram, Fig. 122, and the following concise description of the paths taken by the ammonia, cooling water, and ammonia liquor through various members of the system, abstracted from an article in *Power*, of New York, by Mr F. E. Matthews.

“Cycle Traversed by Ammonia.”—This can be readily traced by following the course of the heavy arrows in the diagram. The circuits of both the gaseous and aqueous components of the aqua ammonia refrigerant, as well as that of the cooling water, can be more readily

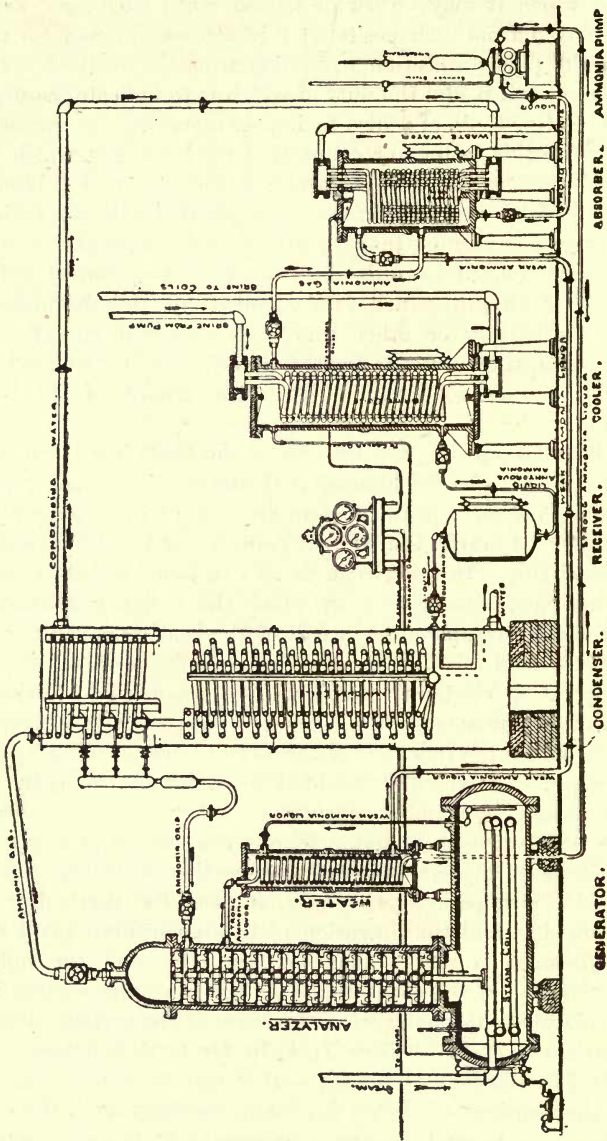

Fig. 121. —Diagram illustrating Leading Type of American Ammonia Absorption Machine.

followed out by means of this diagram, in which all mechanical details have been omitted, and the several members of the refrigerating system are represented by shaded areas occupying approximately the same relative positions on the diagram. The path of the ammonia is represented by a heavy solid line, that of the water component of the aqua ammonia refrigerant by a narrow solid line, and that of the cooling water by a broken line. The direction of travel in each case is indicated by arrows.

“From this diagram it will be seen that, as ‘anhydrous ammonia,’ the refrigerant starting from the ‘anhydrous receiver’ passes to the

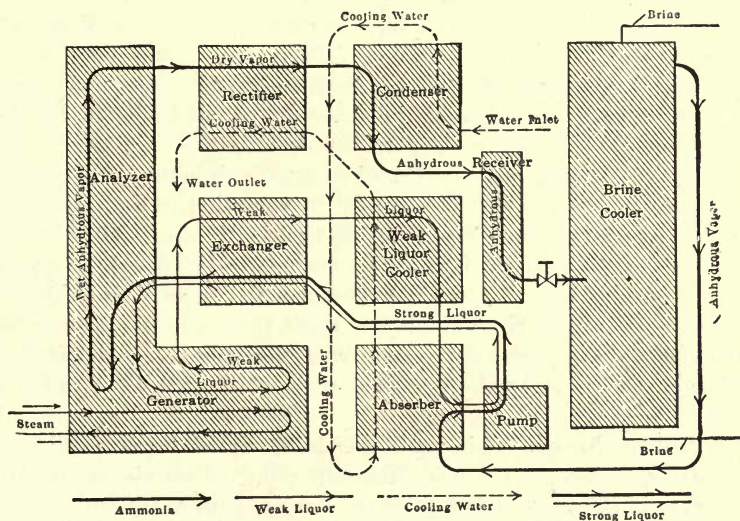

Fig. 122.—Diagram showing Paths of Ammonia, Cooling Water, and Ammonia Liquor through Various Members of Absorption System.

‘brine cooler,’ where, in changing to the gaseous state, it performs its sole function of absorbing heat from the brine. As saturated low-temperature ammonia vapour, the refrigerant starting from the brine cooler passes to the absorber, where it enters into solution or is absorbed by the weak liquor from the generator, forming strong liquor. As hot strong liquor the refrigerant, starting from the absorber, passes through the exchanger, where it gives up some of its heat to the weak liquor on its way to the absorber, then on by way of the analyser into the generator, where the ammonia gas is driven out of the strong liquor solution, under high pressure, by the application of heat, and

passes through the analyser and rectifier into the condenser, leaving the impoverished aqua ammonia or weak liquor behind in the generator.

“In the condenser the heat originally absorbed by the anhydrous ammonia in changing from the liquid to the gaseous state in the brine cooler, as well as that added to increase its temperature and drive it out of solution in the generator, is given up to the cooling water, circulated through the condenser, causing the ammonia to return to the liquid state, after which it flows to the anhydrous receiver, and the cycle is again traversed.

“The aqueous component of the aqua ammonia refrigerant, starting from the bottom of the absorber in company with the ammonia in the form of strong liquor, passes through the exchanger and analyser into the generator. Here it is separated from the greater part of the ammonia and returns through the exchanger and weak-liquor cooler to the absorber. Here it again joins the anhydrous ammonia, forming strong liquor, and retraces the path just described.

“*Path of Cooling Water.*—The cooling water is admitted first to the ammonia condenser, where it performs its most important function of removing heat from and liquefying the ammonia gas. After leaving the ammonia condenser it is still cool enough to be capable of absorbing a considerable amount of heat from the strong liquor in the absorber, more from the weak liquor fresh from the generator in the weak-liquor cooler, and still more from the hot ammonia gas fresh from the generator in the rectifier, after which it usually passes to waste.

“Still another line might have been drawn on the diagram indicating the path traversed by the heat from the point of its absorption from the brine in the brine cooler to that of its expulsion with the cooling water from the condenser. Such a line, however, would coincide with that representing the ammonia from the point where the heat and the vapours of the refrigerant leave the brine cooler, continuing to the condenser, where it would cross over and join that representing the cooling water. It would then follow this line through its circuitous passage to the point where, together with the water, the heat flows away to the sewer.

“It should be noted that throughout the entire system a counter-current effect is carried out between the cooling and the cooled substances.

“By these counter-current cooling effects, in which the coldest cooled substance gives up its heat to the coldest cooling substance, and the hottest cooled substance to the warmest cooling substance,

the outgoing substance is cooled more nearly to the temperature of the incoming cooling substance than would otherwise be possible, thus effecting economy not only in the amount of the cooling substance required, but also in the operation of the system through the reduction in the amount of the refrigerating medium required for a given amount of cooling."

The novel feature in Seeley's absorption machine is the arrangement of the generators, which can be alternately heated by means of steam coils, and which are charged with dry pulverised chloride of calcium. On heat being applied to one of these generators the liberated gas rises, is passed through a condenser, expanded and evaporated in a refrigerator, and lastly returned to the second generator, wherein it is taken up or absorbed by the dry chloride of calcium. Heat is then applied in its turn to the second generator, and the operation is reversed, and so on *ad infinitum*, the generators alternately becoming absorbers.

In a French machine, the refrigerating agent used is amylic ether, which is capable of dissolution under the action of sulphuric acid. The ether is first extracted from the acid under the action of heat, is liquefied under a considerable pressure, and is passed into a suitable receiver or container, from which it can be admitted by means of a stop-cock or valve to spiral ducts surrounding a cylinder or vessel containing the water to be frozen, wherein by its expansion into gas it abstracts the heat, as already mentioned with respect to other machines of this class. The vapour is then returned to a vessel containing sulphuric acid, by which it is once more absorbed, to be subsequently again expelled or driven off therefrom by heat, and to pass through the same cycle of operations as before.

Those machines wherein a refrigerating agent is used, which consists of a compound or dual liquid, one of which is capable of liquefaction at a comparatively low pressure, taking the other or second one into solution by absorption; or, in which the refrigerating agent is liquefied partly by absorption and partly by mechanical compression, are said to work on what is usually known as the binary or dual absorption system.

Johnson and Whitelaw's machine is designed for use with bisulphide of carbon. This refrigerating agent is first vaporised, and with the air introduced by the force-pump is passed through chambers charged with oil, by which the bulk of the moisture of the gas is taken up or absorbed, provision being made for extracting that of the air by passing it through a pipe leading to the air-pump, which pipe is partially filled with chloride of calcium.

Pictet's refrigerating agent consists in a combination of carbon dioxide and sulphur dioxide, which forms a liquid having a vapour tension much less than that of carbon dioxide, or even of sulphur dioxide, at temperatures above 78° Fahr. A cooler or refrigerator patented by Pictet in 1887, which can be employed either with a compression or an absorption machine, has been already briefly described on page 91.

In Nicolli and Mort's machine the refrigerating agent used is ammonia. The apparatus consists essentially in three main parts, viz., an evaporator, a pump, and an absorber, and the operation is as follows:—

The evaporator or generator is first charged with strong ammoniacal liquor, vaporisation being effected by reducing the pressure through the action of the pump, and heat being abstracted thereby from the liquor to be cooled in the usual manner; the evaporator or generator thus performs a dual office inasmuch as it also acts as the refrigerator.

The weak or exhausted liquor passes out at the bottom of the evaporator and is conducted through suitable pipes to the pump, where it meets the ammonia gas or vapour, and, together with the latter, is pumped into coolers, sufficient pressure being applied to liquefy the vapour, and cause a re-dissolution thereof; the strong solution is then returned to the evaporator, passing on its way through an interchanger wherein its temperature is reduced by that of the cold, exhausted, or weak liquor also passing there—through to the pump.

De Motay and Rossi use as a refrigerating agent a mixture of common ether and sulphur dioxide or sulphurous acid (SO_2), which compound is known as ethyl-sulphurous dioxide. It was found by experiments that, at ordinary temperatures, liquid ether has the power of taking up or absorbing large volumes of sulphur dioxide, amounting to as much as three hundred times its own bulk, the tension of the vapour given off from the dual liquid being below that of the atmosphere at a temperature of 60° Fahr.

The two liquids are evaporated in the refrigerator by reducing the pressure through the action of the air-pumps. The pressure in the condenser is at no time in excess of that required to cause a liquefaction of the ether. The capacity of the pump need not be so large as that which would be necessary were ether employed by itself, but it is necessarily somewhat more than that demanded for pure sulphur dioxide.

De Motay and Rossi's apparatus is said to have given very good results in the United States, where it has been used for a number of years.

CHAPTER X

THE COLD-AIR SYSTEM

Principles of—Early Machines—Modern Patterns of Machines—The Allen Dense-Air Ice Machine—Maximum Theoretical Efficiency of Cold-Air Machines—Comparative Tests of Cold-Air Machines.

MACHINES on the cold-air system, that is to say, which abstract heat by first compressing air or other gas, cooling same, and afterwards permitting it to expand, or by first applying heat in order ultimately to produce cold, operate on a principle which is one of the simplest in physics, viz., that the compression of air or other gas generates heat, and the subsequent expansion thereof cold.

Mechanical work and heat being respectively convertible, it follows that should a gas be caused to perform certain work on a piston during expansion, its store of caloric will be exhausted thereby to a degree equal to the thermal equivalent of the work done, the gas after expansion being at a lower temperature than it was before expansion, that is, provided always no heat is supplied from any other source to restore that so lost.

Machines of this kind or class, although they have been used from time to time for cooling hydrocarbons of a volatile nature, are more generally employed with ordinary atmospheric air only, hence they are commonly known as cold-air machines.

There have been several notable improvements made in cold-air machines during the last few years, practically removing most of the old defects, and, in the author's opinion, putting them quite to the forefront for the refrigeration of food-stuffs, and the smaller sized plants giving results which have hitherto been thought impossible, thus enabling them to compare favourably for power, efficiency, and upkeep with machines using chemical agents. Cole's Patent "Arctic" Cold-Air Machine, which will be found illustrated and described in this chapter, is of the most recent type, and embodies some important improvements; the chief amongst these being that all moisture is automatically extracted from the compressed air before expansion, thus

obviating the difficulties that were experienced in earlier machines of this class in the valves becoming clogged with frozen moisture. Figures are given on page 244 showing the results of tests taken by the author from the "Arctic" machines as against those of earlier types; but in addition to the better results obtained in power and efficiency, the freedom from snow and moisture is the great consideration in the preservation of comestibles.

The advantages of cold-air machines are:—First, that no chemicals of any description are required, consequently their employment is not attended by constant dangers from possible explosions and fires, or loss of life through the accidental escape of deadly gases. Very low temperatures can be rapidly obtained by their use. Their construction is comparatively simple, and their application is easy. The entire machine is situated externally to the chamber or store being refrigerated, and every part thereof is consequently accessible at all times.

A matter of the greatest importance with cold-air machines was to ascertain to what degree any water that might be present, either in the form of steam or mist, or of actual liquid, might affect the heating or cooling of air, and alter the working of the machine, besides the formation of snow and ice, which unavoidably resulted therefrom, and which was a most objectionable feature in early machines.

On this head Mr Lightfoot observes: * "The important fact to be noted in this investigation is, that air at constant pressure, having free access to water, will hold a different quantity of water in solution or steam at each different temperature; or conversely the temperature of the 'dew point' for any body of air varies with each quantity of water held in solution by it. The hotter the air, the more water can be held without depositing. (See table on page 573.)

"Thus, if air is highly heated by compression, and water is then admitted to it, in the form of spray or injection, it will take up much more water before becoming saturated than it could have held before it was thus heated. Again, if air under compression and saturated with vapour is allowed to expand, a large quantity of such vapour will condense and freeze into snow, thereby giving up a large quantity of heat to the air, which air is, in consequence, cooled less than it would have been had it been dry air to start with. This freezing is also a serious practical evil, from the deposition of ice about the valves and in the air passages, which necessitates frequent stoppages even in small machines. . . .

"Various means have been devised for ridding the air more or

* *Proceedings, Institution of Mechanical Engineers, 1881.*

less completely of its contained moisture by employing some chemical material, such as chloride of calcium or sulphuric acid, which is a powerful absorbent of water. But, in the author's opinion, the use of such chemicals as are known to him is inadmissible, except perhaps for small machines, or for those working under special conditions, because of the trouble which would be experienced in changing the material and evaporating off the water absorbed, so as to render it again fit for use."

In a subsequent paper * the following particulars are given by the same authority as the result of his very extensive experience in the working of machines of this class:—"The amount of aqueous vapour present in the atmosphere varies from that required to produce saturation down to about one-fifth of that quantity. At any given temperature a volume of saturated air can contain only one definite amount of vapour in solution; and if from any cause additional moisture be present, it cannot exist as vapour, but appears as water in the form of fog or mist. The temperature of saturation, or dew point, varies according to the quantity of vapour in solution; the smaller the quantity, the lower being the dew point. The capacity of air for holding moisture is also affected by pressure, a diminution in volume under constant temperature reducing this capacity in direct proportion.

"In the former paper reference was made to various means that had been devised for ridding the air more or less completely of its contained moisture, in order to obviate as much as possible the practical evils resulting from its condensation and freezing; this being at the time considered one of the most important points in the construction of cold-air machinery. Since then, however, experience has demonstrated that these evils were much exaggerated, and that the condensation of the vapour and deposition of the moisture in the ordinary cooling process after compression, which is common to every cold-air machine, are amply sufficient to prevent any serious deposition of ice about the valves and in the air passages: provided, firstly, that these valves and passages are well proportioned; and, secondly, that proper means are adopted for obtaining in the coolers a deposition of the condensed vapour, which would otherwise pass with the air into the expansion cylinder in the form of fog, and become converted into ice.

"Reference to the table (page 573) shows that, if the compressed air be thoroughly deprived of its mechanically suspended moisture, the amount of vapour entering the expansion cylinder is extremely

* *Proceedings, Institute of Mechanical Engineers*, pp. 225, 226; 1886.

small. Another matter from which the mystery has now been dispelled is the meaning of the term 'dry' air, so much used by the makers of cold-air machinery; this being a point that was just touched upon towards the close of the discussion upon the previous paper. No doubt it is still to a great extent popularly supposed that, unless the air be subjected in the machine to some special drying process, it will be delivered from the expansion cylinder in a moist or damp state, and in consequence be unfitted for use in the preservation of perishable food and for other purposes. But no such state could really exist; for whether the air be specially 'dried' or not, its humidity when delivered from the expansion cylinder is precisely the same, so long as its temperature and pressure remain the same, inasmuch as in practice it is always in a saturated condition for that pressure and temperature. The difference lies in the amount of ice formed, which of course is greater if the amount of moisture entering the expansion cylinder is greater; but this quantity, it has been already stated, may, in the author's opinion, be brought down within perfectly convenient limits by a proper construction of the cooling vessels. In his latest machines, therefore, all special drying apparatus has been dispensed with, the air being simply compressed, passed through a surface cooler, and expanded back to atmospheric pressure."

The invention of the cold-air machine is ascribed to Gorrie, who is said to have designed the first machine of this class in 1849. In Gorrie's machine the cooling water is injected into the compression cylinder, and brine to be refrigerated or cooled into a jacket surrounding an expansion cylinder. His apparatus consists essentially of a double-action pump or compressor, a cooler connected with a compressed air vessel or reservoir, and a jacketed auxiliary pump. The operation of the machine is as follows:—Water is injected into the compressor cylinder at each stroke, on the side of the piston on which condensation or compression is taking place. The compressed air is then led through a worm or coil in the cooler to the compressed air vessel or reservoir, from whence it is admitted to the auxiliary pump, which latter is driven by the expansion thereof. Through the jacket surrounding this auxiliary pump a circulation of brine or other non-congealable fluid is maintained, which brine is cooled by the expansion of the air in the pump cylinder, and which in turn reduces the temperature of an ice-making tank situated above the latter to the requisite degree.

Imperfect cooling of the air after compression, combined with the damp condition of the air, caused the failure of this machine to act in a satisfactory manner.

The next advance was made by Dr Alexander Kirk in 1863. Dr Kirk's machine has three cylinders, viz., one for compressing the air and two for the expansion thereof, all three of which have reciprocating motion imparted to their pistons by a single crank. One of the expansion cylinders is connected to each end of the compressor, thus actually forming two distinct systems. The pistons of the expansion cylinders are hollow and are perforated by a number of small holes, and fitted internally with filters consisting of several layers of very fine wire gauze, the reciprocating action of the pistons alternately causing air to pass through these perforations and filters, and drawing back the air.

The operation of the machine is as follows:—The air is compressed between the piston of the compressor, during its stroke in one direction, and one of the expansion cylinder pistons, the heat of compression being carried off by a suitable water jacket provided round the expansion cylinder. On the descent of the expansion piston the air passes through the perforations, parting with some more of its heat whilst traversing the sheets or layers of wire gauze, and finally expanding in the upper portion of the cylinder and performing work upon the descending piston. The cold air is caused to abstract heat from brine which circulates round the top cover of the expansion cylinder, and through a number of hollow corrugations. The operation of the second or other expansion cylinder which is connected to the opposite end of the compression cylinder is, of course, identical. This machine can be worked up to a pressure of 200 lbs. per square inch, and a temperature of -39° Fahr. has been obtained.

In 1869 a cold-air machine adapted to compress air in stages was invented by Marchant. In his apparatus the air passes first into one cylinder, wherein it is compressed, and is then exhausted into another cylinder of smaller dimensions in which it is still further compressed.

Giffard's first (1873) machine is so arranged that the air mingles in the compression cylinder with sprayed water, which becomes vaporised by the heat of compression, and renders the heat latent. The discharge valve from the expansion cylinder is heated in the piston, and is so adjusted that it will open automatically upon the pressure in the cylinder falling below a predetermined point, the air then passing through to the other side of the piston, and afterwards to the refrigerator.

In the same year (1873) Postle designed a machine which was practically a modification of Kirk's cold-air machine. As in the latter the compression cylinder is connected at each end to an expansion cylinder, but the pistons of the expansion cylinders, which are each

composed of an upper part of smaller diameter and a lower part of larger diameter, are so arranged that when the compressor piston starts upon its stroke in either direction the valve connected with that end of the compressor is forced upon its inner seat, and the air pressure moves that particular expansion piston to the inner end of its cylinder, the valve being opened outwardly, however, before the end of its stroke by its projecting spindle striking against the inner cylinder end, and the latter part of the compression taking place in a small space cooled by a water jacket, and wherein the heat of compression is carried off. Upon the reverse stroke of the piston the valve is raised against its outer seat by the current of air passing through the circumscribed passage around it, and a partial vacuum having been formed above the small portion of the expansion piston, the latter is moved outwardly by the unbalanced pressure in the expansion cylinder, the cooled compressed air passing through the piston to the inner portion of the cylinder.

Similarly, however, to the action on the inward, the valve is opened before the end of the outward stroke of the piston by the other extremity of its spindle coming in contact with the top of the cylinder, but this time outwardly, and the air in the inner portion is thus expanded, and at the same time performs work on the compressor piston. The air reduced in temperature during expansion cools brine circulating through a jacket which also forms the inner cylinder head of both expansion cylinders, the latter being placed end to end.

The great improvement in this machine is that the bulk of the compression is performed during the period wherein the compressor is in connection with the water-cooled spaces, and most of the expansion whilst the compressor is exhausting from the spaces in contact with the brine circulation.

A very decided advance was next made by Windhausen, for whose improved cold-air machine a German patent was granted about this time. The characteristic feature of his apparatus is the improved method by which the air that had become heated by compression is first cooled in a series of condensers or coolers by means of a circulation of cold water, and is then passed into a chamber where expansion or dilation takes place behind a piston. That is to say, in point of fact expansion is effected by the simultaneous action of the machine before the air is utilised for refrigerating purposes.

The original Windhausen cold-air apparatus is shown in plan and side elevation, Figs. 123 and 124, by which the principle of the machine is sufficiently clearly illustrated to render an extended descrip-

tion thereof unnecessary. On the drawing A indicates the compression cylinder, B the expansion cylinder, C the steam engine or other motor for operating the machine, and D, D¹, D², the condensers or coolers through which a constant current of cold water is maintained for

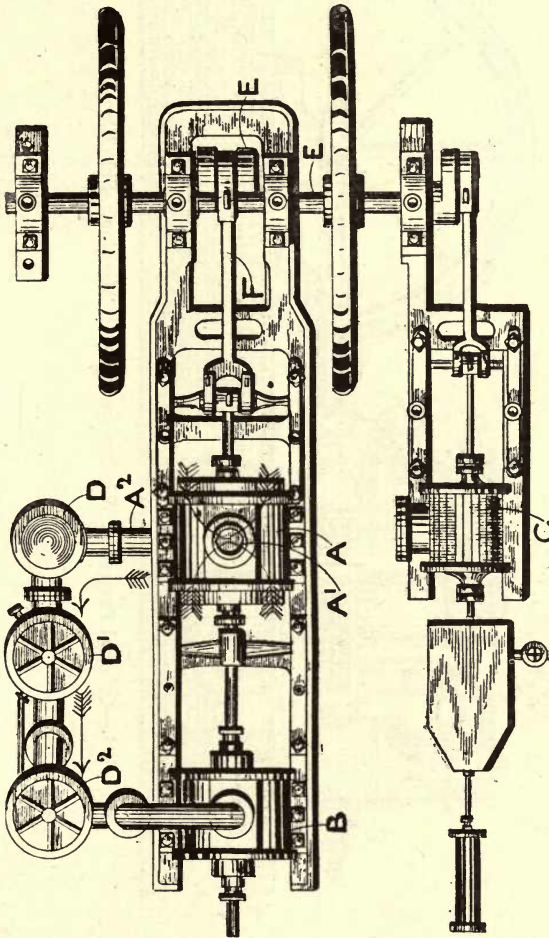

Fig. 123.—Original Pattern of Windhausen Cold-Air Machine. Plan View.

cooling purposes. The cylinders A and B are arranged tandem fashion, and are worked simultaneously from the engine crankshaft E, through the crank E¹, and connecting rod F.

The air enters the compression cylinder A through the inlet A¹, as

indicated by the arrows, and after compression the current passes through the pipe A^2 to the first condenser or cooler D , from which it is

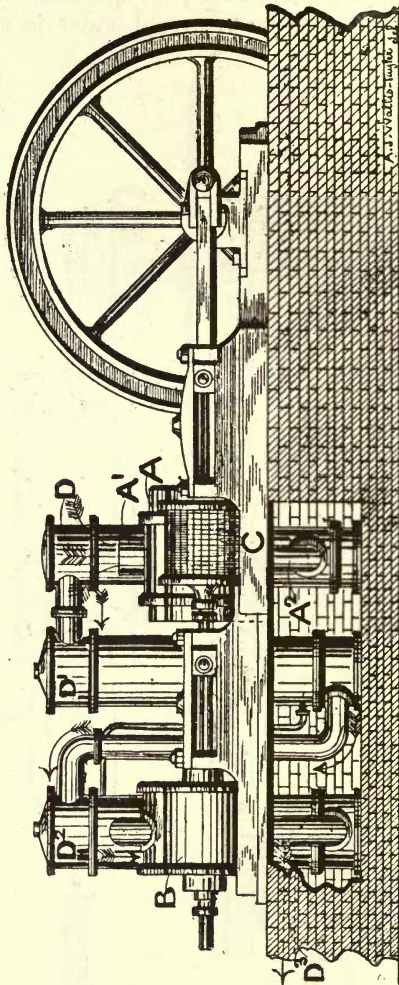

Fig. 124.—Original Pattern of Windhausen Cold-Air Machine. Side Elevation.

conducted successively to the coolers D^1 , D^2 , and from the latter to the expansion cylinder B , as shown by the arrows.

Within the coolers or condensers D , D^1 , D^2 , are arranged a series of pipes through which the blast passes, and around which a constant

circulation of cold water is kept up, the latter entering the cooler D^2 at a suitable inlet, and flowing through the coolers in the opposite direction to the compressed air. A portion of the heat that has been imparted by compression is thus extracted, and the compressed air, which is at a temperature only a few degrees above that of its natural state, is led into the expansion cylinder B, wherein the expansion is effected under a gradually decreasing pressure, which latter is automatically regulated by valves operated by the simple expansive force of the compressed air itself.

Were the air to be dilated to its normal volume it is clear that an amount of heat equal to that which has been abstracted or taken up by the cold water in the coolers would be required; as this, however, can be only partially returned by the small volume of air within the expansion cylinder, a low degree of temperature is immediately obtained, which is more and more reduced with each stroke of the compressor, as the original air in the expansion cylinder is replaced by the cooled compressed air.

From the compression cylinder B the air is conducted to the space to be cooled, escaping with a velocity sufficient to admit of the current being conducted for 300 ft. through a channel 2 ft. in diameter, the temperature at the orifice of the latter being from -30° to -35° Fahr., or from 62° to 67° of frost. It has not been found advisable, however, in practice, to employ a conduit of this excessive length.

In the apparatus shown the dimensions of the compression cylinder are such that at each stroke of the piston 35 cub. ft. of air, and at every complete revolution of the engine 70 cub. ft. of air, are compressed, being reduced to the extent of from two and a half volumes to one volume, or to a pressure of 35 lbs. per square inch; thus, at a speed of thirty-six revolutions per minute, over 150,000 cub. ft. of air will be compressed per hour.

From actual experiments it was found that with the air entering the compression cylinder at a temperature of 80° Fahr., it rose after compression to 205° , thus giving a gain of 125° , inasmuch as this acquired heat is subsequently got rid of in the condensers or coolers and expansion cylinder; and an atmosphere is thus obtained which, whilst under a tension of two and a half atmospheres, is almost at the same temperature as the air previous to treatment, the expansive force, and effect, of a volume two and a half times larger being at the same time retained.

Fig. 125 is a vertical central section illustrating a modified arrangement of Windhausen's cold-air machine, wherein a single cylinder is

used for compression and expansion, the air being condensed or compressed at one side of the piston, and expanded on the other. Two coolers are provided, situated in the bed of the machine, one of which is cooled by a circulation of cold water, and the other by the expansion of the compressed air. The refrigerator is situated above the compressing and expansion cylinder, and receives the expanding air from the expansion side of the cylinder through a temperature regulator.

In the drawing A is the compression side of the cylinder, and B is the expansion side thereof; C is the piston, which is formed hollow and filled with non-conducting material C^1 ; D is the cooler, through which a circulation of cold water is kept constantly flowing, and which is connected to the compression side A of the cylinder through the pipe or tube D^1 and valve D^2 , and E is the second cooler, which is connected

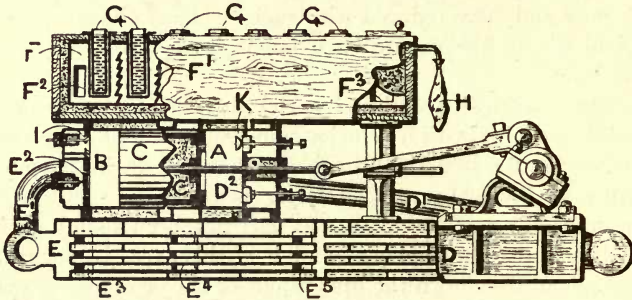

Fig. 125.—Modified Form of Windhausen Cold-Air Machine.
Vertical Central Section.

to the first cooler D, and to which a certain amount of the expanding compressed air from the expansion side of the pump is admitted for cooling purposes. The tubes in both the coolers D and E, through which the compressed air passes from the compression side A of the cylinder, communicate through the pipe or tube E^1 and valve E^2 with the expansion side B thereof.

F is the ice-making tank or refrigerator, and G, G are the ice cans or cases. The ice-making tank F consists of a double-cased rectangular wooden box or vessel, the spaces between the outer and inner cases of which are filled or packed with loose cotton, or other suitable non-conductor of heat. The cover, which is formed of a single thickness of wood, is pierced with holes in which are fixed metallic cases or pockets for receiving the ice cans G. F^1 , F^1 are zigzag partitions arranged between the rows of ice cans, so as to cause the air to come

fully into contact with the metallic cases or pockets supporting them. *H* is an india-rubber bag, which acts to maintain a uniform pressure within the ice-making tank or refrigerator *F*, by admitting or giving out air in accordance as to whether the pressure happens to be above or below that of the atmosphere. *I* is a valve which is open during the entire compressing stroke of the piston *C*, and which communicates through a suitable pipe or tube with the temperature regulator, from which a portion of the expanding air passes to the ice-making tank or refrigerator through a tube communicating therewith through the aperture *F*², the remainder being delivered through another pipe or tube to the space round the compressed air tubes in the cooler *E*, through the aperture or orifice *E*³, with which latter space the ice-making tank or refrigerator is likewise connected through a suitable pipe or tube, and the apertures *F*³, *E*⁴.

The temperature regulator and pipes or connections are situated at the rear of the apparatus, and are not shown in the drawing. The compression side *A* of the cylinder is also connected with, and derives its supply of air from, the expanded air space in the cooler *E* through a suitable pipe opening into the latter at *E*⁵, and communicating with the former through the valve *K*.

The operation of the apparatus is as follows, that is to say: The piston *C*, during its forward or compression stroke, compresses the air contained in the compression side *A* of the pump cylinder, and under the pressure of this air the valve *D*² opens, and the latter passes through the pipe or tube *D*¹ to the water-cooled tubes of the first cooler *D*, from which it then passes to the air-cooled tubes of the second cooler *E*. The cool compressed air next flows into the pipe or tube *E*¹, and is admitted through the valve *E*² to the expansion side *B* of the pump cylinder during a portion of the stroke, when the valve *E*² is closed, and the air expands in the chamber *B* during the remainder of the stroke. The cooled and expanded air flows out of the expansion chamber *B* through the valve *I*, during the entire return or back-stroke of the piston *C*, to the temperature regulator, from whence a portion of it passes to the ice-making tank or refrigerator *F*, and the remainder to the space round the compressed air tubes in the second cooler *E*. On the return or back-stroke of the piston *C*, the air in the space round the tubes in the second cooler *E* is drawn or sucked into the compression chamber *A* through the inlet valve *K*.

The improvements introduced into cold-air machines in 1877 by Bell-Coleman added very considerably to their practical value. This invention comprises suitable means for cooling the air, both in and as

it leaves the compressor, by spray or jets of water, and also for drying it again before it is passed into the expansion cylinder. The latter object is effected by causing it to flow through a set of coils, or pipes, situated in the chamber cooled by the machine; or by providing for exposing these pipes to a current of the used or spent air passing out from the chamber.

On leaving the compressor the moist air is first passed through a chamber with perforated diaphragms, and is then conducted to the expansion cylinder through coils or pipes which have a very extended surface, and are cooled on the exterior to a lower temperature than that of the cooling water, thus still further reducing the temperature of the air, and inducing a deposition of moisture.

A great objection to this system of cooling by internal injection is the loss occasioned by the saturated condition in which the air, even when employed continuously over and over again, is constantly delivered to the machine.

In 1877 Giffard also greatly improved his (1873) machine, and brought it to the form shown in Fig. 126. In the drawing (which illustrates the apparatus in side elevation, some of the parts being shown in vertical central section) A indicates the compression cylinder and B the expansion cylinder, which are both of the single-acting type, and open at their upper ends; C is the condenser or cooler. The inlet and outlet valves to the expansion cylinder B, as also the inlet valve to the compression cylinder, which, as shown in the drawing, are situated in the lower ends to these cylinders, are actuated through cams upon the shaft of the machine. The outlet valve from the compression cylinder A governs the delivery of the compressed air to the lower end of the condenser or cooler C, wherein, after passing through top and bottom chambers or spaces and a central series or set of vertical water-cooled tubes, it is delivered through a suitable pipe to the inlet valve of the expansion cylinder, from which latter, after doing work upon the expansion piston, during its upward stroke, it is discharged during its return or downward stroke through the outlet valve (shown on the right-hand side) and led away through a suitable pipe to perform its cooling office where desired. The compression cylinder A is jacketed, and the heat generated during compression removed as far as possible by a circulation of cold water.

In operation the air which enters the compression cylinder A through the inlet valve (shown on the right-hand side) is first compressed up to the normal pressure existing in the condenser or cooler C, when the outlet valve lifts and admits of its being passed into the

latter, wherein it is cooled and dried by contact with the water-cooled tubes. The valve regulating the admission of compressed air to the expansion cylinder B is so arranged that it will admit to the latter an

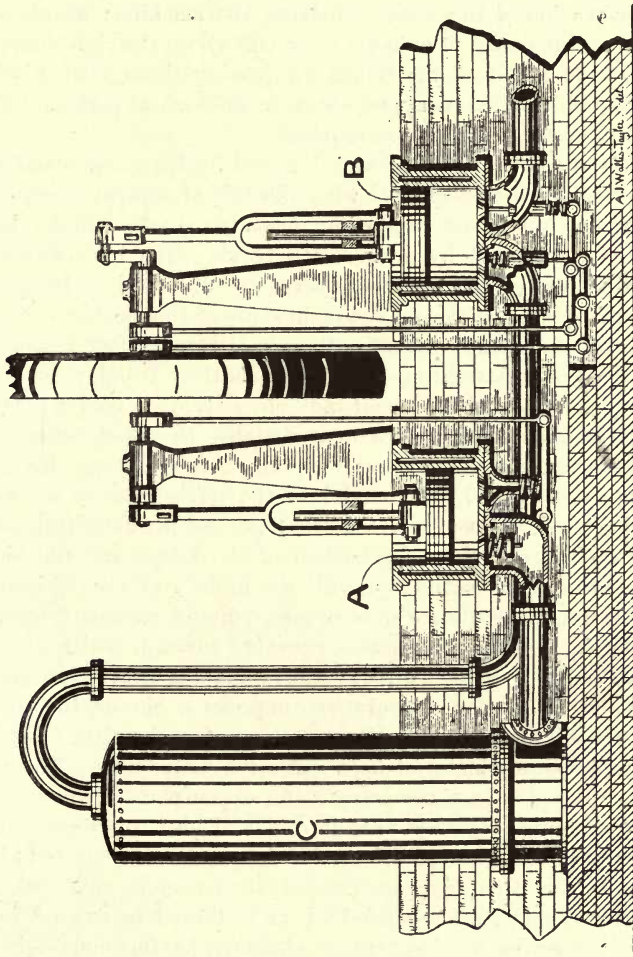

Fig. 126. — Improved Type Giffard (1877) Cold-Air Machine. Sectional Side Elevation.

amount of air equal to that which is being forced into the condenser or cooler c during the downward or compression stroke of the compressor piston, thus tending to maintain an equality of pressure in the condenser. The pistons are thus constantly moving in opposite direc-

tions, that of the expansion cylinder being, however, a quarter stroke in advance of that of the compressor. During the upward stroke of the expansion piston, the inlet valve from the condenser or cooler *c* (shown on the left-hand side) remains closed, the expanding air performing a portion of the work of driving the machine; whilst on the down stroke the outlet or exhaust valve (shown on the right-hand side) opens, so as to admit of the cooled air passing through the discharge pipe, by which it is led away, as above mentioned, to perform its cooling or refrigerating office where required.

A form of cold-air machine was designed by Hargreaves and Inglis in 1878, wherein they dispensed with the use of separate compression and expansion cylinders, employing instead a single cylinder having two pistons connected by means of a trunk. The inlet and outlet valves, which are of the Corliss pattern, are arranged to be operated through suitable eccentrics on the main shaft of the machine.

In Tuttle and Lugo's machine the air is forced after compression through a set or series of tubes in a cylindrical or tubular chamber or vessel, which is cooled by a constant circulation of cold water, and through a similar set of tubes in a chamber or vessel, wherein the latter are surrounded by a volatile liquid. After leaving this second vessel the air is allowed to expand into the refrigerator or ice-making tank, rising through some such volatile liquid as ether or bisulphide of carbon; which is placed in the bottom of the latter, and the air and the vapour from the volatile liquid fill the interior of the refrigerating chamber surrounding the ice cans or cases, and freeze or congeal the water therein. A by-pass is also provided through which the compressed air can be conducted direct to the ice-making tank or refrigerator.

Lugo and M'Pherson's apparatus comprises a blower, the air from which is forced through a cooler consisting of a chamber filled with some suitable porous material kept saturated with water. The cooled air is then passed into a compressor, the upper part of which is kept full of water, which serves to keep it cool and also to prevent leakage of the air past the piston. From the compressor the air is led to a cooler, and from this to a compressed air reservoir or vessel, from which latter it is in turn admitted to, and allowed to expand in, the interior of a large ice-making tank or chamber, having non-conducting walls and rails for cars carrying the ice cans or cases. The piston of the compressor is worked by La Hire's epicycloidal device.

Hick Hargreaves' machine is of the double-acting horizontal type, water being injected into the compressor at each stroke for cooling purposes. After compression it is passed through a series of receivers

wherein the watery particles carried over are deposited, after which it flows into the expansion cylinder, in which it is expanded down to the pressure of the atmosphere. Corliss cut-off gear is fitted to the inlet valves of the expansion cylinder. A large snow-box is provided in the air-trunk, fitted with baffle or check plates for arresting the snow, which, as the air enters the expansion cylinder fully saturated with moisture for its temperature and pressure, becomes rapidly filled with snow, and requires to be frequently cleared out.

Stevenson's cold-air machine is also of the horizontal pattern, the compression, expansion, and steam cylinders having their pistons coupled to a single crankshaft. The compression and expansion cylinders are single-acting, and are arranged to face each other, their pistons being coupled by means of T-headed rods, which form vertical guide bars, between which is arranged to slide a motion block driven by the crankshaft, and thus to impart the requisite reciprocating motion. The steam engine is either single-acting and of the trunk type, or of the simple high-pressure, condensing, or compound type.

Sturgeon's horizontal pattern machine is so constructed that the compressed air is delivered into a cooler formed of sets of tubes surrounded by a circulation of cooling water, whereby its temperature is partially reduced, and it is afterwards caused to pass through some absorbent material, such as charcoal, before admission into the expansion cylinder.

In 1880 Haslam (Sir Alfred Seale Haslam) brought out a cold-air machine of the type usually known as dry air refrigerators, which comprises certain very important improvements on the Bell-Coleman type of machine, and which had the effect of rendering it one of, if not the most successful machines of this class hitherto designed.

Figs. 127, 128, and 129 are perspective views illustrating three different cold-air machines of the Haslam-type.

That shown in Fig. 127 is of the horizontal pattern, and is made in sizes adapted to deliver from 20,000 to 30,000 ft. of air per hour. Compound duplicated horizontal machines of heavier build are, however, also constructed, in sizes adapted to deliver from 35,000 to 300,000 ft. of air per hour. The apparatus is driven by a compound condensing engine, and this, together with the air compressing and expansion cylinders, and the requisite water-pumps, are all mounted upon a cast-iron bed frame, of box section, cored out to receive the air-cooler, engine, surface condenser, and air-pump. This combination of the condenser casing with the refrigerator forms a foundation for

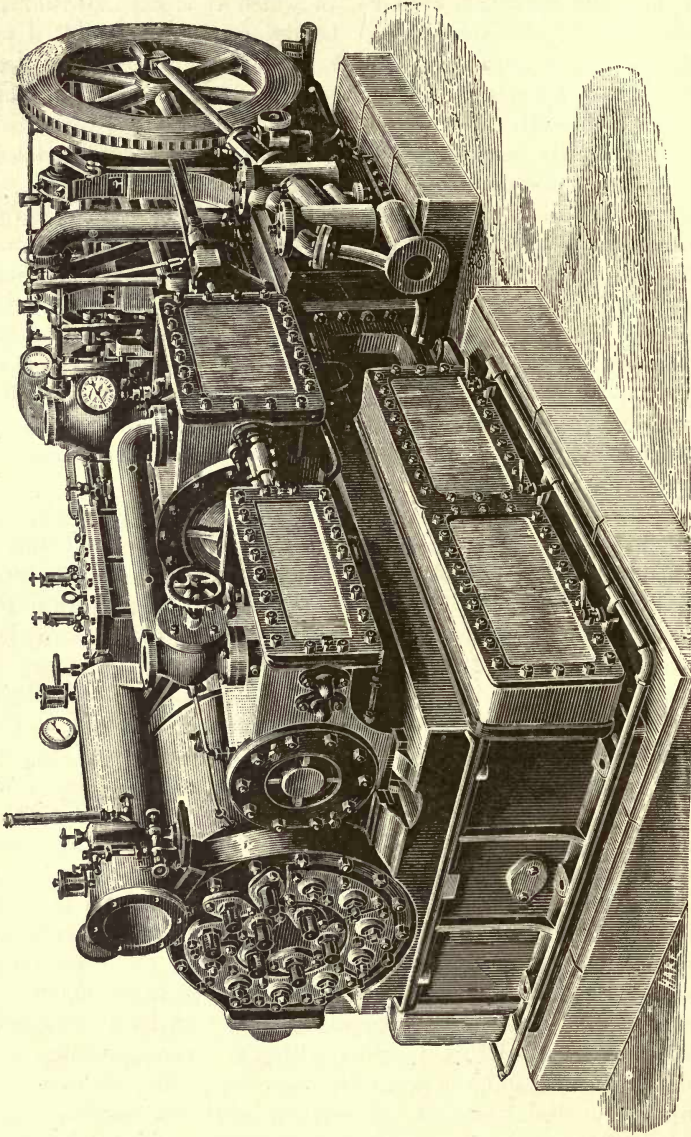

Fig. 127.—Haslam Cold-Air Machine. Horizontal Pattern.

the bed-plate of the steam engine. The feed-pumps are bolted on to the side of the bed, and are driven from an overhead rocking shaft, which likewise works the air-pump. Variable cut-off gear is fitted to both the steam cylinder and the air-expansion cylinder, and the pistons of both the compressor and expansion cylinders are directly coupled to tail rods from the steam cylinder pistons. By locating the inlet and outlet valves in the cylinder covers they are rendered very easy to get at for repairs and other purposes. The height of this machine is such as to admit of its being conveniently placed "between decks" of steamers.

The patent diagonal pattern machine (Fig. 128) is made of smaller sizes, viz., to deliver from 10,000 to 12,000 cub. ft of air per hour, and where a machine of still smaller capacity is required, one of the vertical pattern, such as that shown in Fig. 129, is preferably used, the latter machines being constructed of sizes to deliver from 2,000 to 6,000 cub. ft. per hour. In the diagonal pattern machine the compound high and low pressure steam cylinders, and the air-compressor cylinder, are placed on the top of the bed, the air-expansion cylinder is located at the end, and the water, air, and feed pumps are bolted to the side thereof.

The bed is, as will be seen from the illustration, of massive box section, and is suitably cored out to receive the water-cooler tubes, the condenser tubes, and the patent drying pipes, and it likewise supports the main crankshaft bearings. The condenser tubes are fixed in position by means of screwed ferrules, and the air-cooler tubes and drying pipes are secured in tube plates by expanding the ends in the usual manner. The several tube plates are provided with covers having ribs arranged for the proper circulation of air and water. As will be seen, the machine is peculiarly compact and self-contained, and the air-pump is arranged vertically, and is worked through a T-bob from an eccentric on the crankshaft.

The type of machine illustrated in Fig. 129 occupies but little floor-space, and its height allows of its location "between" decks of small steamers and yachts. The steam cylinder, air-compression cylinder, and expansion cylinder are mounted vertically upon cast-iron standards, which latter are securely bolted to a cast-iron bed of hollow box section, supporting the crank shaft bearings and containing the air-cooler, and the water-pump is bolted to the base-plate and worked vertically from a crosshead pin.

The crank shaft, valve rods, and connecting rods, are of mild forged steel, and the slides are of the open type and easily accessible. A

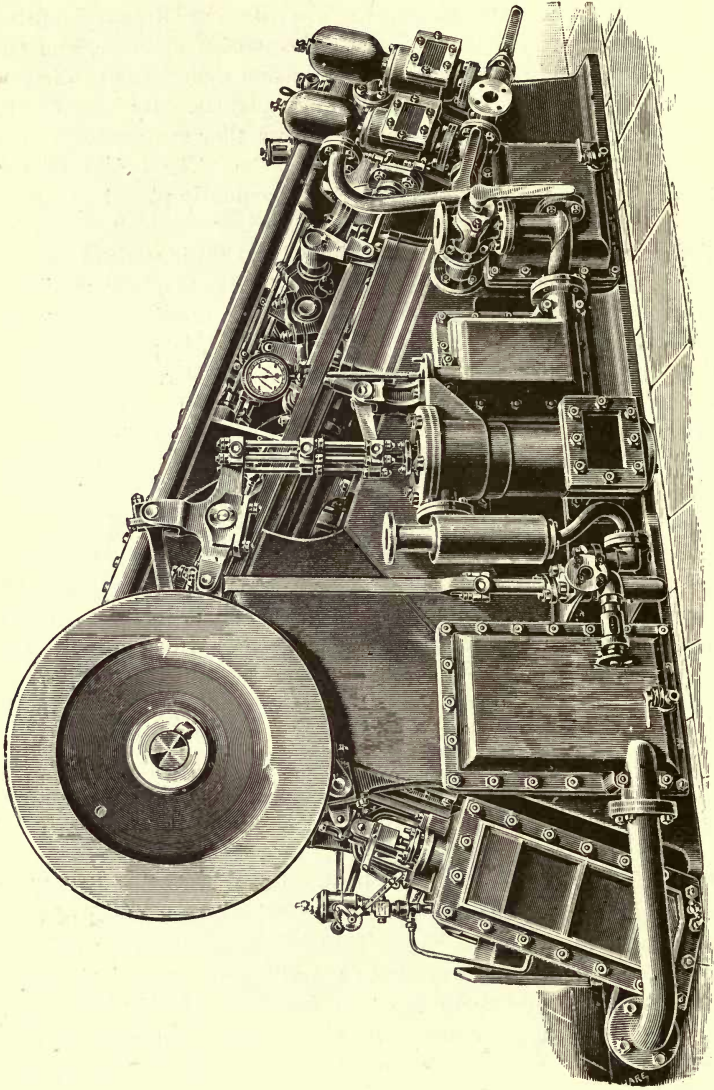

Fig. 128.—Haslam Cold-Air Machine. Diagonal Pattern.

portion of one of the cast-iron standards is made loose so as to admit of the crank being readily removed when desired.

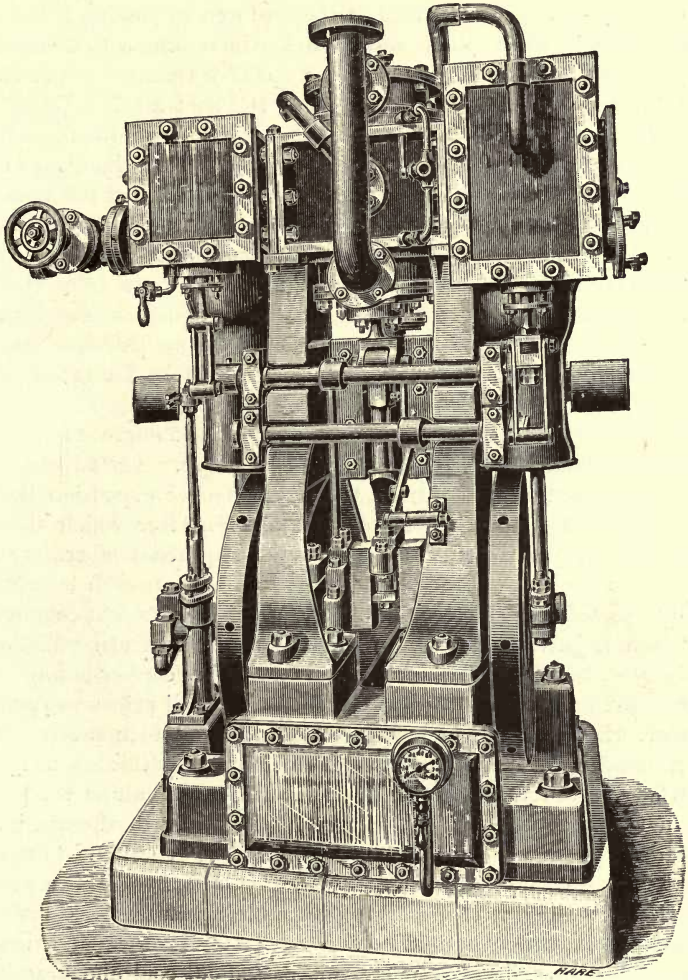

Fig. 129.—Haslam Cold-Air Machine. Vertical Pattern.

The above machines all have double-acting cylinders. The compressors are either of the water injection type, or of the dry type and water-jacketed, discharging into the surface coolers in the beds. When

a compressor of the first or water-injection type is employed, the above-mentioned cooler is dispensed with, and a separate water tower is provided. After being cooled in the ordinary way by water, the temperature of the compressed air is still further reduced by passing it through an interchanger, wherein it is subjected to the cooling action of either the spent cold air leaving the enclosed space or chamber where it has been used for cooling purposes, or else of the cold air as it passes out of the expansion cylinder. In the first instance separate boxes containing the drying pipes are provided inside the cold chamber, in the second case the device is fitted in the forepart of the bed of the machine; the advantage derived from both these arrangements is that a further condensation and deposition of moisture are thereby effected. The exhaust valves of the expansion cylinder are separate from the admission valves, and they are so designed as to afford as few obstacles to the free passage of the air there-through as practicable. Marine types of cold-air machines made by this firm will be found described and illustrated in the chapter on Marine Refrigeration.

In the same year (1880) Lightfoot introduced an improved machine, wherein the expansion is performed in two stages. The advantage of this arrangement is that during the first stage of expansion the air can be made to deposit most of its moisture, after which the dry air is further expanded until it attains the required temperature and pressure.

The operation of Lightfoot's machine is as follows:—The compressed air, which is partially cooled, and which when direct atmospheric air is employed, is always in a condition of saturation corresponding to its temperature and pressure, is first passed into a small primary expansion cylinder, wherein it is expanded beneath a piston to a pressure that will give a final temperature of about 35° Fahr. By this means almost the whole of the vapour held in suspension in the air is condensed, and in the form of mist is discharged, together with the air, into a separator, upon the surfaces of which the mist is deposited in the form of water, and, falling to the bottom, is drawn off. From this separator the dried air, which is still at a considerable pressure, is conducted to the second expansion cylinder, in which latter it is expanded down to the pressure of the atmosphere, and passed out cold and practically freed from moisture.

The following table* gives the calculated relative amounts of vapour condensed and deposited in the various stages of cooling, with a machine on the Lightfoot system, capable of delivering 15,000

* *Proceedings, Institution of Mechanical Engineers, 1881.*

cub. ft. of cooled air per hour, and dealing with air in a tropical climate, having an initial temperature of 90° Fahr., and fully saturated with vapour:—

| | Lbs. | Per hour. | Per cent. |
|---|-------|-----------|-----------|
| Total amount of vapour entering with the air - | ... | 45·36 | 100·00 |
| Deposited as water in the cooler - | 33·61 | ... | 74·10 |
| Deposited as water after first expansion - | 9·26 | ... | 20·40 |
| Discharged as ice in cooled air - | 0·93 | ... | 2·05 |
| | — | 43·80 | ... |
| Balance, being residual vapour still existing in cooled air - | - | 1·56 | 3·45 |

Fig. 130 is a vertical central section through the air compression and expansion cylinders and the valves of one of the Lightfoot pattern of cold-air machines, which may be classed amongst those which have afforded satisfactory results, as far at least as the cold-air system is concerned. A is the compressor, which is of the double-acting type; and B is the expansion cylinder, which is of the single-acting type.

The cylinders A and B, which are arranged tandem style or fashion, and have a common piston rod, are placed close together, sufficient clearance being left, however, to permit of the inspection or examination of the pistons being conveniently effected. An advantage of this arrangement is that the coldest portion of the expansion cylinder is placed at a distance from the hottest end of the compressor.

The air-valves are circular slides formed of phosphor bronze, and are operated by eccentrics in the ordinary manner. The advantages claimed for this type of valve are, that they admit of the parts being formed very short and direct, are perfectly noiseless in action, and allow of a high piston speed being used without any injurious results. They are said to have been found to work very satisfactorily, and to have given no trouble as regards wear, even when in almost constant use for some years.

The coolers consist of a pair of iron vessels fitted with sets or clusters of solid drawn Muntz-metal tubes $\frac{3}{4}$ in. external diameter. Through these tubes and the compressor jacket cold water is constantly circulated for cooling purposes in an opposite direction to that taken by the compressed air, by means of a force-pump driven off the crank-shaft. Any water that may become deposited from the air by condensation in the coolers is blown off through suitable drain cocks.

After passing through both the coolers the compressed air is reduced in temperature to within some 5° or 6° of the initial temperature of the cooling water; the amount of the latter that is

required being usually from 30 to 40 gals. for every thousand cubic feet of cold air discharged, or some three or four times the weight of the air. From the second cooler the cooled compressed air is con-

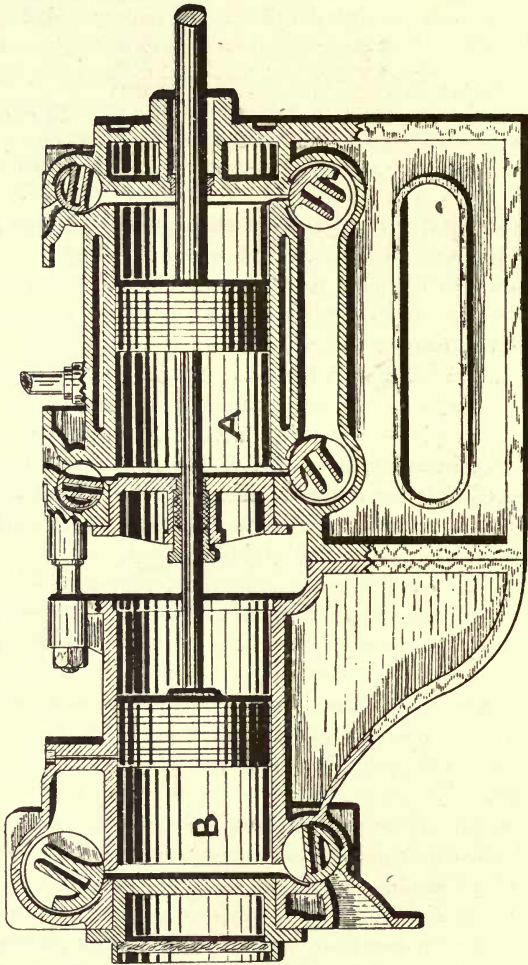

Fig. 130.—Lightfoot Double-Acting Cold-Air Machine, Horizontal Pattern.
Vertical Central Section.

ducted to the expansion cylinder B, where it performs work upon the piston, and so returns some 60 per cent. of the power that has been expended in its compression, and is then exhausted at a temperature of from -70° to -90° Fahr., or 102° to 122° of frost.

The steam engine is either of the high pressure or of the condensing type; in the latter case the jet or surface condenser is placed below the cylinder, which is overhung from strong brackets on the bed-plate, and the air-pump is operated from a continuation of the piston rod. It will be seen that this arrangement admits of a condensing engine being employed without occupying any additional space, or it allows of the engine being compounded by the addition of a second cylinder tandem fashion, in which case the condenser is preferably located below the high-pressure cylinder, and the air-pump is driven off a crankpin in the fly-wheel. When a condensing engine is used, the cooling water, after performing its work in the coolers, is passed to the condenser.

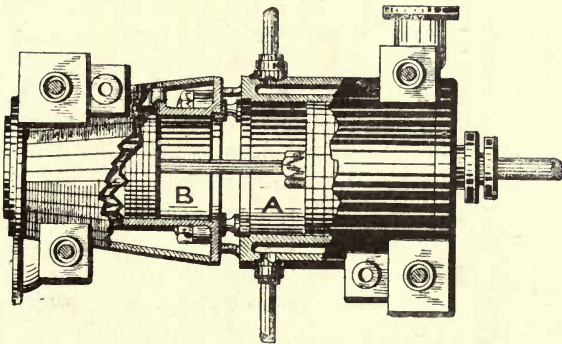

Fig. 131.—Lightfoot Single-Acting Cold-Air Machine.
Sectional Elevation.

Fig. 131 is a side elevation partly in vertical central section, showing the air cylinders of a single-acting Lightfoot cold-air machine.

Lightfoot machines of the vertical pattern, with the exception that the coolers are cast in one piece with the frame, do not differ in construction to any material degree from those of the horizontal type.

The Hall cold-air machine, when driven by a steam engine, has three double-acting cylinders located side by side at the end of a suitable bed-plate, one of which is for steam, the second for compression, and the third for expansion of the air. The cylinders have the usual arrangement of moving parts, that for compressing the air being water-jacketed, and the connecting-rods working on cranks on the same shaft. The valves for the compression and expansion cylinders consist of main and expansion slides operated from two weigh-bars. These valves were in some earlier types of machines situated on the under

side of the cylinders, but in those of later patterns they are located on the top side of the cylinders, where they are very readily accessible. The coolers, which are placed below the bed-plate or frame, are arranged for surface cooling and are of the ordinary multitubular type. An interchanger was also sometimes provided with the older types of machines, wherein the air that had done duty in the storage or cold chambers was utilised for further reducing the temperature of the compressed air. In more recent machines, however, a patented form of centrifugal moisture separator has been used for drying the compressed air.

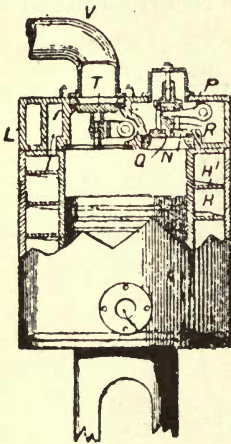

Fig. 132. — Cole's "Arctic" Cold-Air Machine, with Auxiliary Cooling Arrangement. First Pattern. Sectional Elevation.

An illustration of one of the most recent and improved types of Hall cold-air machines will be found in the chapter on "Marine Refrigeration."

The "Arctic" cold-air machine is of an improved type, brought out in 1899 by T. & W. Cole, Ltd., London. Fig. 132 is a sectional elevation, showing one of the first patterns of machine. In this machine the air, after compression in the cylinder and water spray cooling, is further cooled by passing it through a vessel containing glass balls, &c., on trays over which water is sprayed. It then passes through an annular jacket, and the hollow head L of the expansion cylinder for additional cooling. The jacket contains either a spiral partition H¹, which may be perforated, or spirally-placed baffles. The head L contains positively-worked inlet and exhaust valves. The compressed air in its passage to the expansion cylinder circulates through the circuitous passages of the cylinder jacket, and is thereby cooled to a temperature of about 32° Fahr. (many degrees lower than the cooling water) before entering the expansion cylinder. This low temperature having the effect of depriving the air of all excess of moisture, prevents the clogging of ports and passages with snow, which for many years has been the great objection to the more general use of most cold-air refrigerating machines (*vide* page 241). In the case of small cold-air machines, this difficulty has generally been considered insurmountable, but is claimed to have been overcome in the small machine of 1,250 cub. ft. capacity illustrated.

A later type of machine is shown in Figs. 133 and 134, and in Figs. 135 and 136, the first two being general views of a small and a large sized machine, and the others respectively a side elevation,

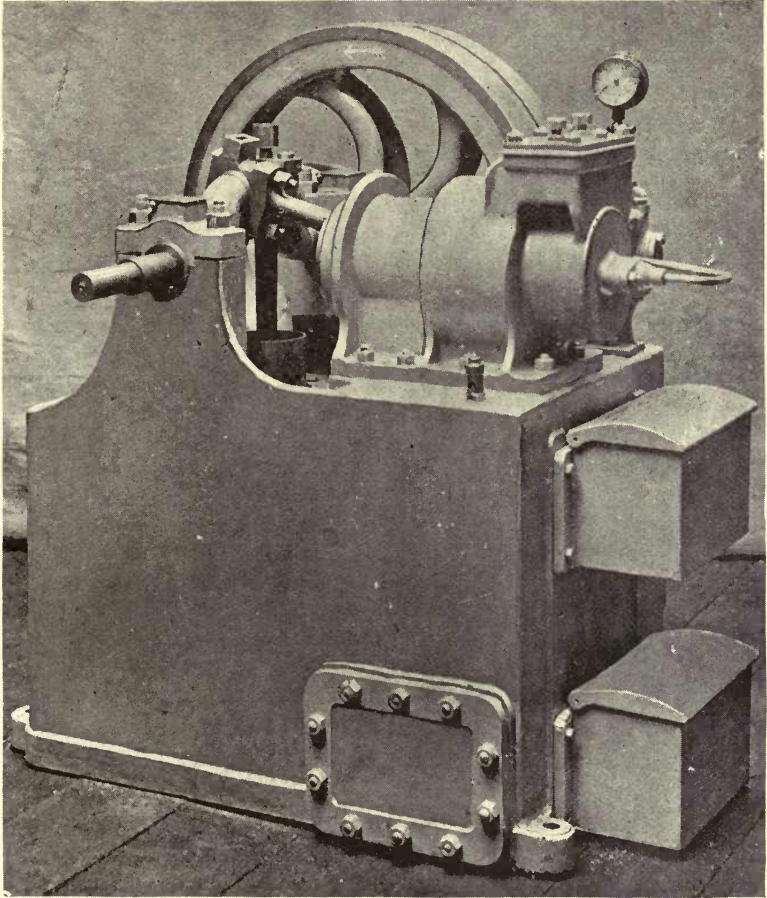

Fig. 133.—Cole's "Arctic" Cold-Air Machine, with Air-drying Arrangement. Small Size. Belt-driven Type.

partly in section, and a transverse section of expansion cylinder. In this arrangement also the compressed air is passed round the expansion cylinder, and cooled to some 27° lower than the available cooling water,

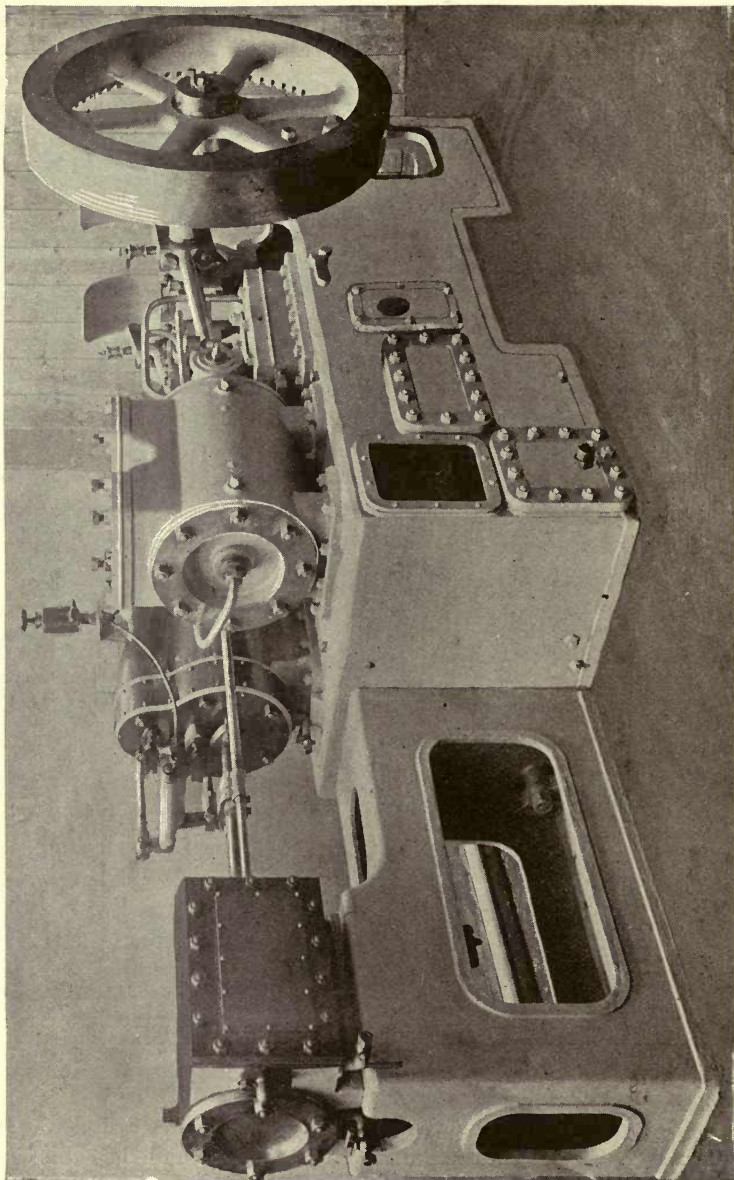
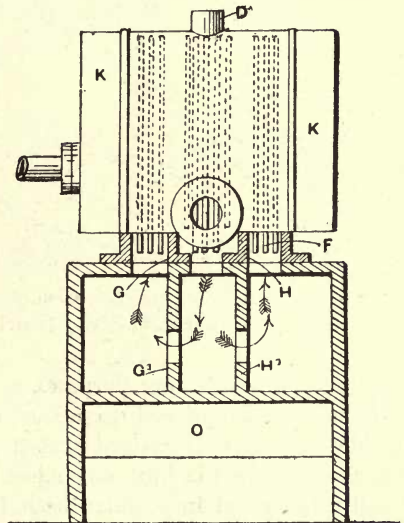
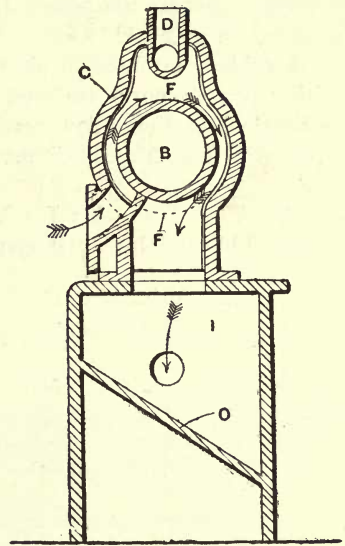

Fig. 134.—Cole's "Arctic" Cold-Air Machine, with Air-drying Arrangement. Large Size. Steam-driven Type.

and thus deprived of most of its moisture. This cylinder B is jacketed at C, and provided with ribs F and partitions G, H, which is arranged to make the air take a circuitous course round the cylinder and its ends to the valve boxes K, and the jacket may be extended to include the pipe D leading the expanded air to the refrigerating chamber. The base or bed I for this cylinder also contains partitions G¹, H¹ for circulating the air, and it has a sloping bottom o with a water seal or valve to remove the condensed moisture. Before passing round the expansion cylinder, the air from the compressor is passed through a chamber containing spheres, &c., over which water trickles, and then through a series of tubes to remove some of the moisture after the preliminary cooling. The illustrations show a double-acting expansion cylinder, as described above, but the invention is applicable to vertical or to single-acting cylinders, and the arrangements of the partitions and ribs, and consequently the course of the air, may be varied. The compression and expansion cylinders may be mounted on a bed containing the cooling arrangements.



Figs. 135 and 136.—Cole's "Arctic" Cold-Air Machine, with Air-drying Arrangement. Side Elevation partly in Section and Transverse Section.

Figs. 137 and 138 show indicator diagrams taken respectively from a double-acting and a single-acting expander of an

"Arctic" cold-air machine. The data connected with this test will be found on page 244.

A cold-air machine, or air compression refrigerating machine, comprising certain novel features, or, to speak more correctly, a novel application, is the Allen machine, which is known as the "Allen Dense-Air Ice Machine," made by Frank Allen, Brooklyn, New York.

The Allen Dense-Air Ice Machine is illustrated diagrammatically in Fig. 139, and briefly it comprises the following parts:—A steam

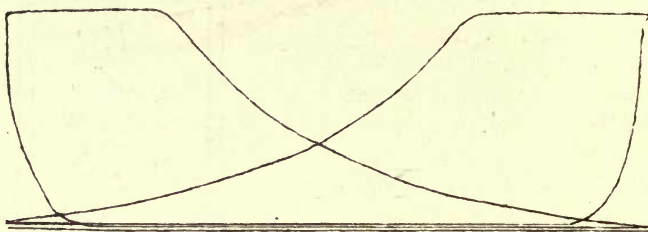

Fig. 137.—Indicator Diagram from Double-Acting Expander of "Arctic" Dry Cold-Air Machine. (For Data of Test see page 244.)

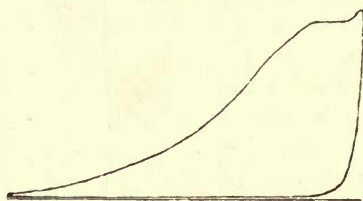

Fig. 138.—Indicator Diagram from Single-Acting Expander of "Arctic" Dry Cold-Air Machine. (For Data of Test see page 244.)

cylinder *q* for driving purposes, a compression cylinder *r*, in which the air is compressed to about three times its primary pressure, which cylinder is water-jacketed to prevent injury to the piston packings from the heat engendered by this compression. A copper coil *s*, immersed in a water bath, into which coil the compressed air is passed and cooled, or reduced to the temperature of the cooling water. A return air-cooler *t*, by means of which the compressed air is further cooled by the cold air returning from the cold storage chamber. An expansion cylinder *v*, wherein the cooled compressed

air is allowed to expand to one-third of the tension of compression, that is to say, to its original pressure, on entering the compressor cylinder, during which operation it is cooled as much as it was previously heated by the compression, and leaves the cylinder at a very low temperature. This cooled air is then discharged into a well-insulated pipe, by means of which it is conveyed to the place which it is desired to cool. Here the pipe service is left exposed; that is to say, it is not insulated, and the cold air, after taking up the heat from the surrounding matter, is again returned

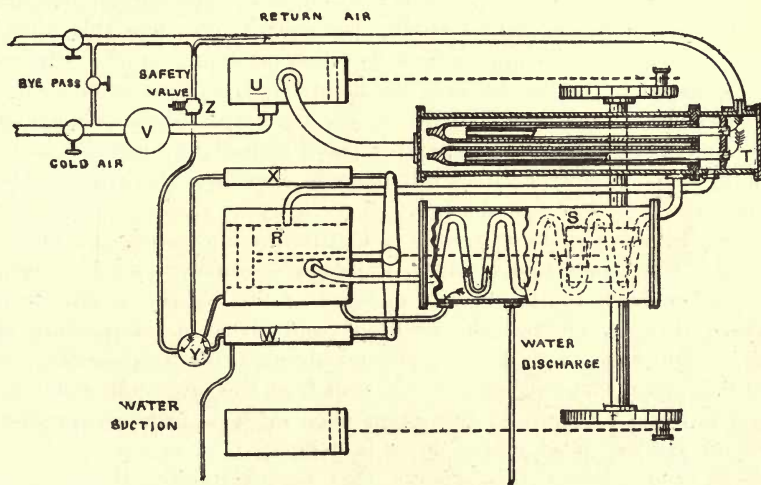

Fig. 139.—Allen Dense-Air Ice Machine. Diagrammatic View.

to the compressor, where it is again subjected to compression, cooled, and expanded as before.

A suitable trap or separator, as indicated at *v*, is also provided for eliminating the lubricating oil used in the cylinder, as well as any snow that may be formed, from the cold air. The deposits are removed from this separator by heating the latter through a suitable steam pipe, and running off the contents through a drain pipe and cock, the machine being so arranged that any frozen deposits from the expansion cylinder will be at the same time thawed and blown out into the separator. In operation the separator requires blowing out once or twice in every twenty-four hours.

Cooling water for the separator, the copper air-cooling coil bath, and the water jacket round the compression cylinder, is supplied by an ordinary plunger-pump *w*, and a small supplementary air-pump *x* is also provided for charging the system when starting with air up to the necessary pressure, and also for making up any losses that may occur by reason of leakage through stuffing boxes and joints whilst the machine is running. To extract the moisture from this fresh supply of air to the system it is passed through a drier or separator *y*, by means of which it is dried as far as practicable before entering the machine. *z* is a safety valve.

The operation of the apparatus is as follows:—The normal pressure of the air in the system is 60 lbs. per square inch, and this air is compressed in the compressor to 210 lbs. per square inch. Should it be found impossible to keep up these relative pressures of 60 lbs. on the suction side and 210 lbs. on the discharge side, it is a sign of leakage. The oil trap or separator being choked by congealed oil or snow, or the closing of valves will likewise cause a disturbance in the pressures.

It will be seen that the air is in this machine used in a closed cycle. The compressed air from the compression cylinder is cooled, expanded down to its original pressure of 60 lbs. per square inch whilst doing work, and the resultant cold air at a temperature of about 60° below zero Fahr. is forced through the refrigerating or cooling pipes, where it takes up the heat from the surrounding objects, and is again returned to the compression cylinder to be compressed, cooled, and expanded, and so on *ad infinitum*.

It is claimed for this machine that by maintaining the air at a constant pressure of five atmospheres (60 lbs. gauge pressure) it can be conveyed in pipes of comparatively small diameter, and the rise of temperature will be slight. No absorbed water vapour has to be cooled from the vapour to the frozen condition, and the greater efficiency of the dense air or air under pressure enables a very much smaller machine to be used than would be the case with an ordinary cold-air machine for the same capacity.

The only additional moving part in the Allen dense-air ice machine is the small auxiliary or primer pump which is a simple plunger-pump of ordinary construction. There are also the closed refrigerating pipe system, and the two traps by means of which the lubricating oil and water are removed or eliminated from the air, and the latter is maintained in a pure condition whilst passing through the pipes.

It will be obvious that the refrigerating or cooling pipes will be arranged in the cold storage room or chamber in a similar manner to those of any direct expansion ammonia plant. As no chemical circulating agent or medium is employed, the items of expense comprise only the steam consumed in the driving engine or motor, the necessary lubricating oil, and the labour of attending to the machine, which the makers state are small.

The efficiency of dense-air machines is low, and as compared with ammonia compressors, they consume from ten to fifteen times the horse-power. Dense-air refrigerating machines have been used to some extent on board warships belonging to the United States owing to the immunity from danger in case of leakage.

In a paper* on "Refrigerating Machines," by Arthur Robert Gale, C.E., the author makes the following observations on refrigerating machines of the cold-air type:—"One of the chief difficulties in cold-air machines is the presence of moisture held in suspension by the atmosphere; this applies especially to the open cycle machines. Moisture in the air occasions loss of efficiency in two ways. If the air enters the expansion cylinder in a saturated condition, when the air is cooled by expansion whilst performing work, a certain amount of vapour is condensed and thrown down—the point of saturation being dependent on the temperature. The vapour, in changing to the liquid state, gives its latent heat of vaporisation to the air; and as the expansion of the air continues, and the temperature is still further diminished, the liquid freezes and accumulates in the form of snow and ice in the valves and passages, giving up its heat of liquefaction to the air. Thus not only does the presence of moisture in the air produce mechanical difficulties, choking the air passages and impeding the action of the valves, but, for the same expenditure of energy, the cold air leaves the machine at a higher temperature than would have been the case if there had not been a superabundance of moisture in the air during expansion.

"As the cold-air machine is the direct reverse of the heat-engine, so also its conditions of greatest efficiency differ from those of the latter. The maximum theoretical efficiency of a refrigerating machine may be expressed by the formula—

$$\frac{Ha}{E} = \frac{T}{T_c - T}$$

* *Minutes of Proceedings, Inst. C.E.*, vol. cxviii., Session 1893-94, pp. 421-422.

where E is the thermal equivalent of the work of compression,

H_a denotes heat-units abstracted by the system,

T_c denotes absolute temperature at which rejection of heat takes place,

T denotes absolute temperature at which absorption of heat takes place.

From the above it follows that—

$$E = H_a \frac{T_c - T}{T},$$

i.e., in any refrigerating machine the greatest efficiency will be obtained with a small range of temperature; the greater the range the smaller the efficiency will be, other conditions being equal; also the efficiency is increased as the lowest limit of the range of temperature is raised. Thus a machine working between the temperatures of 100° Fahr. and 0° Fahr. would, other conditions being unaltered, be more efficient than when working between 60° Fahr. and -40° Fahr. These remarks are applicable to any system of refrigeration, and are not peculiar to the cold-air machine."

For some time it was very generally supposed that many kinds of provisions of a perishable nature were liable to receive damage from the snow held in suspension in the cold air from these machines, and it was this fear of injurious effects which prompted inventors to design those forms of special drying apparatus intended to remedy this defect, such as the Bell-Coleman interchanger, wherein the air is dried by passing it through a series or set of coils situated in the chamber cooled by the machine; of the improved form of the above designed by Haslam, wherein the interchanger is cooled either by the spent cold air on its leaving the chamber wherein it has been utilised, or by the cold air as it passes out of the expansion cylinder; the Lightfoot machine, wherein the expansion is performed in two stages; or of Hall's centrifugal moisture separator (or the air-drying arrangement of T. & W. Cole). Hence the term "dry-air refrigerator."

This objection to the cold-air machine arose, however, from a fault the evil effects of which, it has now become evident, have been undoubtedly much exaggerated, as in practice no such damaging results to the contents of the stores or chambers are experienced as it was supposed and predicted would ensue, although of course the snow that is formed in the manner above described is an undeniably objectionable product. If a cold-air machine be worked on the principle of exclusion of the aqueous vapour, after a few cycles of operations

the air will have become dry, and will thenceforward work like a true gas.

Owing to their compactness and simplicity, to the non-requirement of any chemicals, and to the great facility of application, cold-air machines are found to be very suitable for marine installations, and for this purpose they are extensively employed. They are also, however, in use to a considerable extent for refrigerating cold stores or chambers for the preservation of provisions of a perishable nature.

An objection, however, to machines of the Bell-Coleman type, wherein the air is partially cooled during compression by the injection of cooling water into the compressor, is experienced at sea, by reason of the corroding action of the salt water, in addition to the loss of efficiency common to all machines of this class. Considerable difficulty has been experienced in tropical climates, where, with the cooling water at about 90° Fahr., the moisture-laden air would be delivered into the cooling pipes at a temperature of 95° Fahr., or more, and the absolute pressure would be about 65 lbs. per square inch. Now, as there is, as Mr Lightfoot observes,* “precisely the same amount of dry cold air circulating outside the cooling tubes in a given time as there is warm compressed air within, it follows that by whatever amount the temperature of the internal air is reduced, by an equal amount must that of the external air be raised. But, in addition, the internal air has vapour mixed with it, which, as the temperature falls, gives off heat, measured not only by the reduction in its sensible temperature, but by the latent heat of vaporisation; and this heat also has to be taken up by the external air. It will be found that, assuming each pound of internal air, with its proportion of vapour, to be reduced to 42° Fahr., the pound of external cold air, which has to take up all the heat due to this reduction, will be raised in temperature by 84° Fahr.”

This defect is obviated in machines of T. & W. Cole’s “Arctic” type, as the air is cooled by their drying arrangement some 25° lower than the cooling water. Thus in tropical climates, where the cooling water would be about 90°, the compressed air would be cooled down to 65°, and thus be deprived of a great proportion of its suspended moisture before being admitted to the expansion cylinder.

Instead of using the spent air for cooling purposes, the cold air from the expansion cylinder may be applied direct to the cooling apparatus; but in this case difficulty would be experienced from the

* *Proceedings, Institute of Mechanical Engineers, 1881.*

FORMULA FOR CALCULATING THE AMOUNT OF AIR DELIVERED PER HOUR BY COLD-AIR MACHINES, WHEN THE REVOLUTIONS AND THE SIZE OF THE COMPRESSORS ARE KNOWN.

This is given as follows by Messrs Haslam in their catalogue of ice-making and refrigerating machinery :—

$$\text{Air discharged per hour} = \frac{A \times N \times 2R \times S \times 60}{1728} \times C.$$

Where A = Area of each compressor in inches,

N = Number of compressors,

2R = Strokes per minute (or twice the revolutions),

60 = Minutes per hour,

S = Stroke in inches,

1,728 = Cubic inches in 1 ft.,

C = Factor of efficiency which is taken as .8 for short strokes, and .85 for long strokes.

CHAPTER XI

COCKS, VALVES, AND PIPE JOINTS AND UNIONS

Expansion or Regulating Cocks and Valves—Stop-Cocks and Valves—Suction and Discharge Valves—Pipe Joints and Unions—Means for Increasing the Cooling Surface of Pipes.

EXPANSION OR REGULATING COCKS AND VALVES.

A NUMBER of cocks or valves are required on every refrigerating machine, the most important being, however, the expansion or regulating cock or valve, or as it is sometimes called, the flash-cock or valve, which serves to control the connection between the condenser and the refrigerator or evaporator.

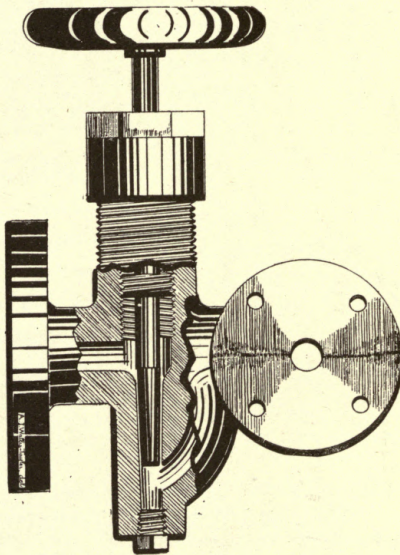

Fig. 140.—Taper Spindle Expansion or Regulating Valve.
View partly in Vertical Section.

Fig. 140 is a view partly in vertical central section, and Fig. 141 is a vertical central section showing two patterns of a very common form of expansion valve of the taper spindle type which are adapted for use with manifolds. The construction of these valves is obvious from the drawings, the taper spindles and valve boxes or casings are made of hardened steel, and whilst extremely simple in construction the type is, perhaps, all things considered, about the most effective arrangement for general purposes.

Figs. 142 and 143 show in vertical central section the $\frac{1}{2}$ -in. angle

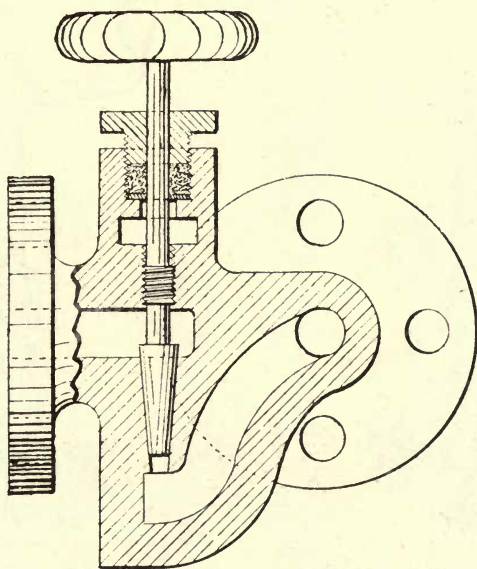

Fig. 141.—Taper Spindle Expansion or Regulating Valve.
Vertical Central Section.

and globe expansion valves employed by the Triumph Ice Machine Company. These valves are made of the best machinery steel, and are so constructed that they can be packed at any time. The drawings are self-explanatory, as is also that shown in Fig. 144, representing a vertical central section through the Frick expansion valve, which is constructed of drop steel forgings.

Fig. 145 is a plan, Fig. 146 is a vertical central section, and Fig. 147 is a view of the plug partly in vertical section through the port or way, showing the De La Vergne improved expansion cock.

The port or passage through the plug (Figs. 146 and 147) is so formed as to admit of the nicest regulation being effected. With this object the round hole is not carried completely through the plug, but only through about three-quarters the thickness thereof, as shown in Fig. 147, and the remaining thin bridge of metal is perforated in the shape of a very narrow wedge as shown in Fig. 146.

The plug is rotated by means of a worm and worm-wheel in the manner which can be clearly seen from the drawing, and whereby

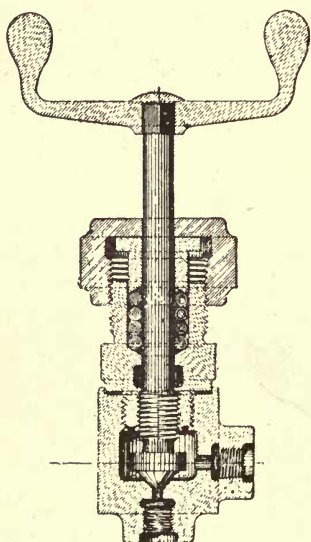

Fig. 142.—Triumph Angle Expansion or Regulating Valve. Vertical Central Section.

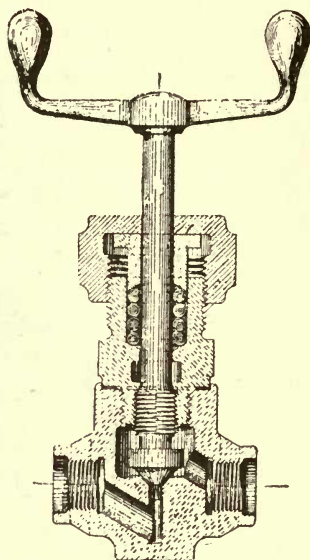

Fig. 143.—Triumph Globe Expansion or Regulating Valve. Vertical Central Section.

very fine or delicate adjustment can be readily imparted thereto. The narrow wedge-shaped passage or aperture allows of the flow of the liquid ammonia being regulated to the minutest possible amount, the point or apex thereof being the first to open.

The stop-cocks or valves described in a patent taken out by Puplett and Rigg in 1887 for regulating or completely cutting off or arresting the flow of the gas or liquids to the various parts of the apparatus have metal seats. To prevent leakage of the gas or liquid, the stuffing boxes of these valves are provided with screwed glands, which are likewise

screwed on to the valve spindles, which latter are screw-threaded for their entire length, and are packed with some suitable yielding fibrous or metallic packing, such, for instance, as hemp or lead. This packing is caused to enter into the screw threads upon the spindles as the

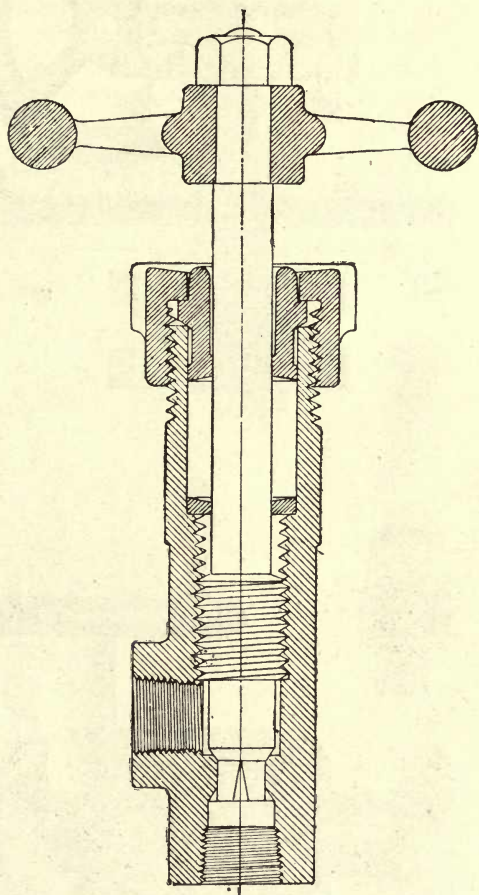

Fig. 144.—Frick Angle Expansion or Regulating Valve.
Vertical Central Section.

glands are forced or screwed down, thus making gas-tight joints round the latter without causing the valves to set fast. A description of the Pontifex expansion or regulating valve will be found on page 187, being one of the improvements included in his 1887 patent.

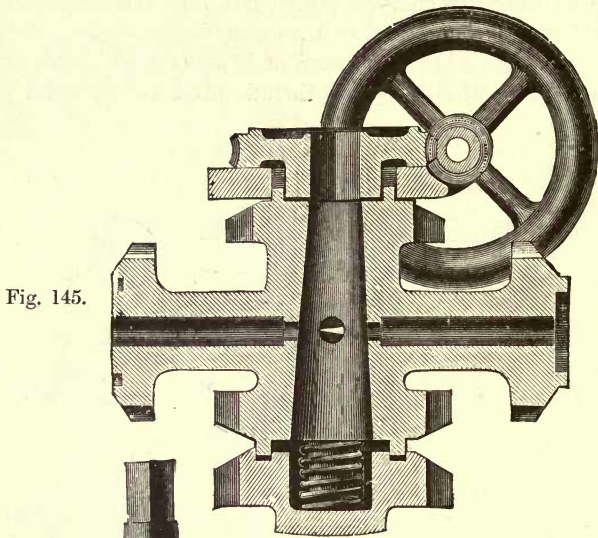

Fig. 145.

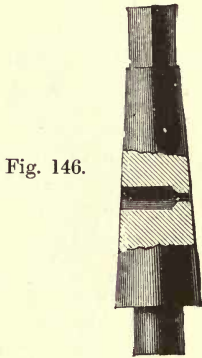

Fig. 146.

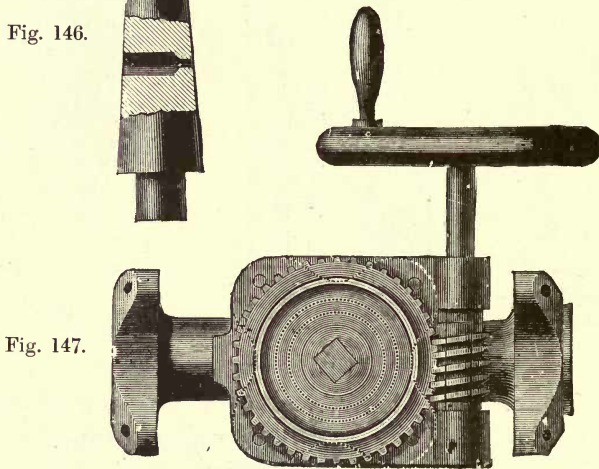

Fig. 147.

Fig. 145.—De La Vergne Expansion or Regulating Cock. Vertical Central Section.
 Fig. 146.— Do. do. do. View of Plug partly in Section.
 Fig. 147.— Do. do. do. Plan.

A form of expansion valve for use with ammonia or other compression machines has been designed by Suppes and Dortch of Ohio, U.S.A., which, it is claimed, obviates the formation of ice upon the exterior of the valve owing to the intense cold which is produced at this point by the expansion of the ammonia or other agent. Briefly, the expansion valve now under consideration comprises a valve and casing having a pipe member connecting the expansion orifice of the valve with the refrigerating coil, which valve is provided with an ice-guard consisting of a member of a comparatively large area secured to the exterior of the valve casing adjacent to the valve. This ice-guard or member performs the double office of, firstly, absorbing heat from the atmosphere, and in this manner preventing an undue reduction in the temperature of the valve casing from taking place; and, secondly, of forming a barrier over which the

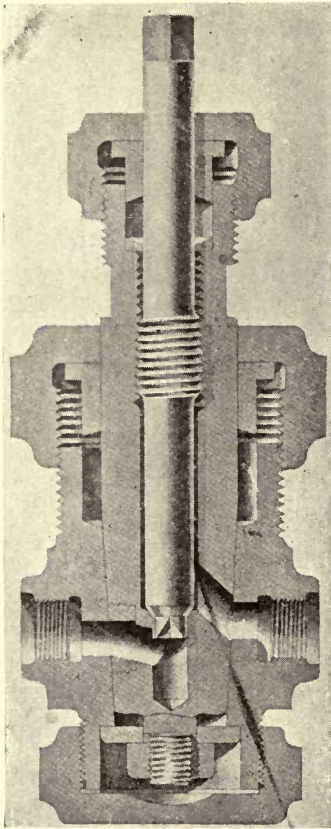

Fig. 148.—Triumph Safety Combination Expansion Valve and Stop-Cock. Vertical Central Section.

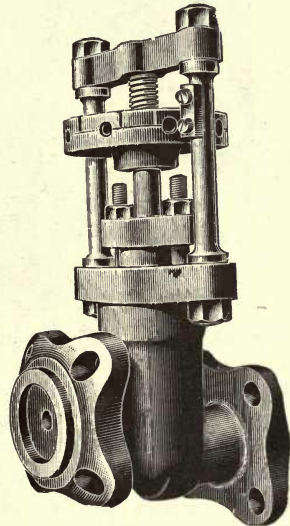

Fig. 149.—Haslam Improved Type of Expansion Valve.

ice which accumulates on the pipe member must creep before it can reach that portion of the casing surrounding the valve.

In Fig. 148 is illustrated the Triumph safety combination expansion valve and stop-cock. With this valve there is no necessity for pumping out or shutting down the plant, as it can be repaired at any time by shutting off the stop-cock, removing the stem and inserting in its place a short plug which is sent out with each valve. Expansion can then be effected with the stop-cock, which has a V-shaped opening at both ends, so that no mistake can be made as to which direction it is

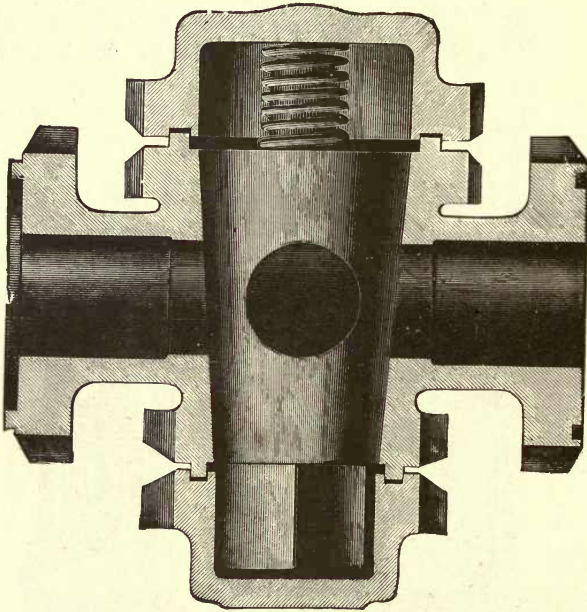

Fig. 150.—De La Vergne 2½-in. Stop-Cock. Vertical Central Section.

turned. When the expansion valve is repaired, all that is required is to simply shut off the stop-cock again, remove the short plug, and reinsert the valve stem, after which work can be resumed as before.

Fig. 149 shows the Haslam improved type of expansion valve which is especially adapted for fine adjustment.

STOP COCKS AND VALVES.

The De La Vergne improved form of stop-cock for ammonia gas is illustrated in Figs. 150 and 151, which show vertical central sections

through the shells or casings of a $2\frac{1}{2}$ -in. and a 1-in. cock, the plugs being left in elevation.

As will be seen from the drawings, the square for operating the plug is, contrary to the usual custom, placed at the small end thereof, the latter being pressed to its seat by a spiral spring inserted between its large end and a cap bolted up to the shell or casing, and having an annular projection adapted to engage in a corresponding groove formed in the latter, and wherein is provided a lead or other washer. Similar means for forming a gas-tight joint are provided at the small end of the plug, and in this manner the escape of any fluid into the chamber that might chance to pass the plug is prevented. The even and constant pressure of the spiral spring maintains the plug always on its seat, and prevents any grit or other impurities from getting between

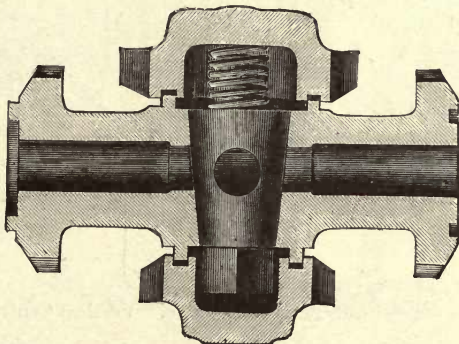

Fig. 151.—De La Vergne 1-in. Stop-Cock. Vertical Central Section.

the surfaces and cutting or abrading them. The shell of the small-sized cock or valve (Fig. 151) is of slightly modified form.

The Kilbourn stop-cock is provided with a cone, gland, nut, or sleeve, and collar, so constructed and combined that by turning the gland nut in the one direction the cone will be forced into and held in its seating, whilst on the other hand by turning it in the other, or opposite direction, the cone will be started from its seating.

The construction of the Triumph Ice Machine Company's stop-valve is such as to admit of its being packed at any time without running the risk of loss of gas. The valve has double seats, and the valves, when closed, clamp the seats so that it is impossible to have any leakage. The seats are formed of lead, so that should they at any time be injured by foreign matter, by simply removing the damaged

seat and inserting a new one a new valve is secured at only the expense of a lead seat. Fig. 152 shows one pattern of shut-off or

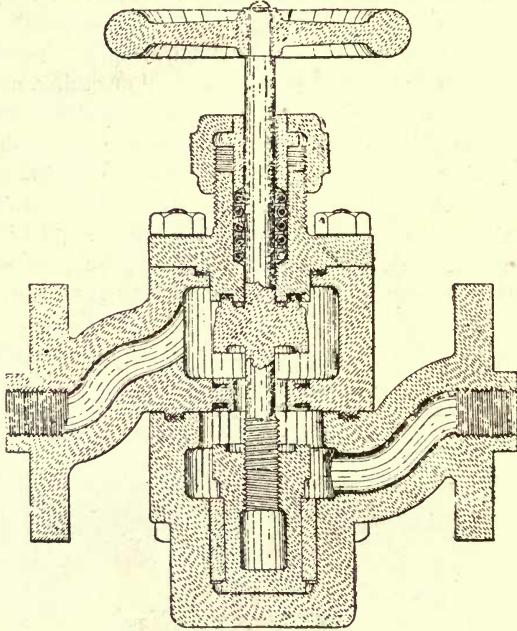

Fig. 152.—Frick Shut-off or Stop-Valve. Vertical Central Section.

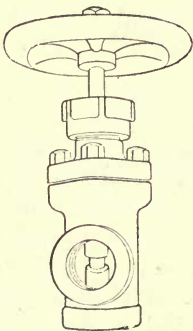

Fig. 153.—Frick Stop-Valve.
Perspective View.

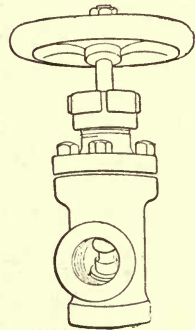

Fig. 154.—Frick Stop-Valve.
Perspective View.

stop-valve used by the Frick Company. Figs. 153 and 154 are two other patterns of stop-valves made by the same company.

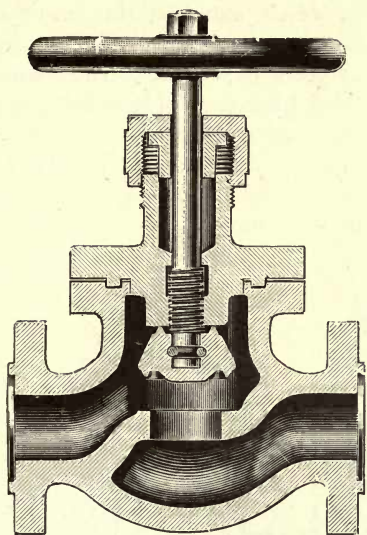

Fig. 155.—Haslam Standard Type of Ammonia Valve for Connections over 1 in. diameter.

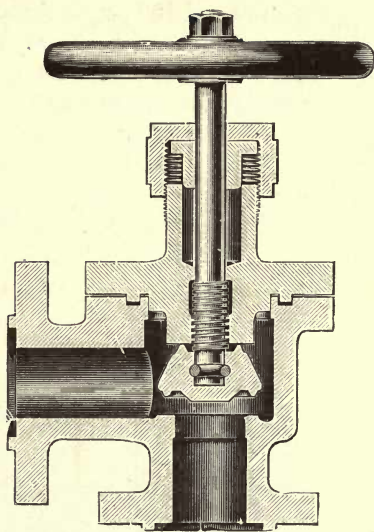

Fig. 156.—Haslam Standard Type of Ammonia Valve for Connections over 1 in. diameter.

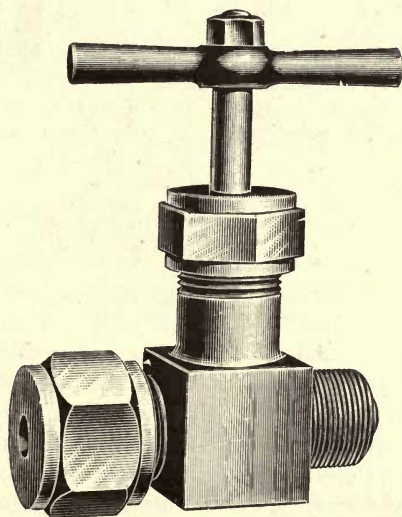

Fig. 157.—Haslam Small Steel Valve for Gauge and other Connections under 1 in. diameter.

Figs. 155 and 156 are sectional views of the standard Haslam type of ammonia valves such as are supplied for all sections over 1 in. in diameter, and are the outcome of many years' experience. The bodies of the valves are constructed of a special mixture of gun-iron, the valves and spindles being of steel. A special feature of this type of valve is that the gland can be repacked at any time without possibility of loss of ammonia. Fig. 157 illustrates a small steel valve used for gauge and other connections under 1 in. in diameter.

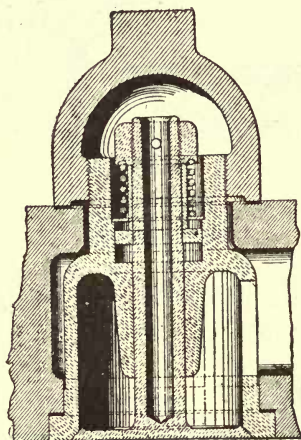

Fig. 158. —Discharge Valve, Hercules Compressor. Vertical Central Section.

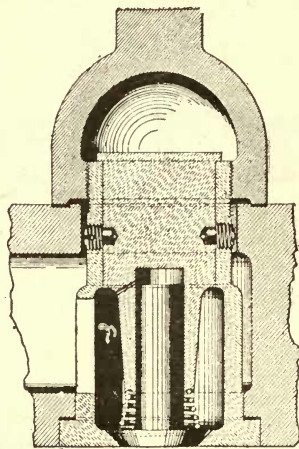

Fig. 159. —Suction Valve, Hercules Compressor. Vertical Central Section.

SUCTION AND DISCHARGE VALVES.

Compressors for ammonia or other volatile refrigerating agents are usually provided, in the case of a vertical single-acting machine, with two valves—a suction and a discharge valve—at one extremity of the cylinder only; and a double-acting horizontal machine has as a general rule four valves—two, viz., a suction and a discharge valve, being located at each end of the cylinder. It is hardly necessary to remark that these valves must, like all other valves in the system, be maintained tight, but, in addition to this, these particular valves are all held against their seats by suitable steel springs; and it is a matter of the greatest importance, as regards the securing of the utmost economy in working possible, to see that the proper amount of tension is put upon these springs.

Should the spring governing the discharge valve of a compressor be too strong, then it is evident that an undue amount of pressure will have to be exerted in order to raise it from its seat, and hence a loss will be experienced. Still worse is it if the spring on the suction valve be over powerful, as in this event an excessive amount of suction will

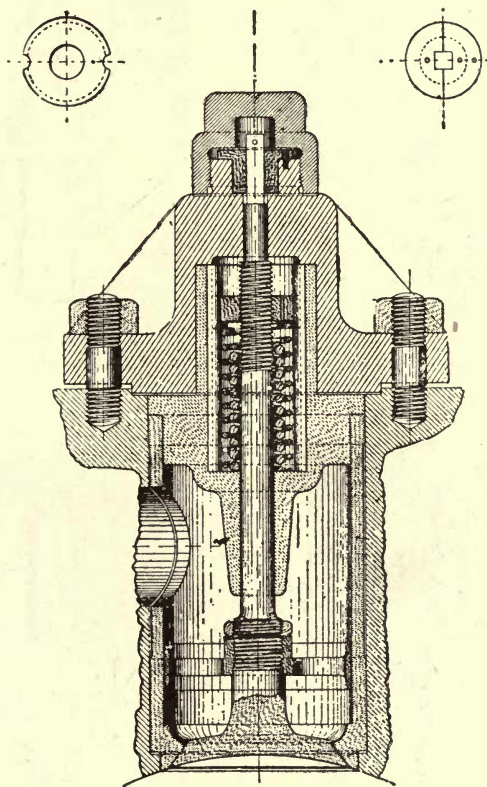

Fig. 160.—Triumph Suction Valve. Vertical Central Section.

have to be produced in order to effect the raising of the valve off its seat, thereby creating a serious interference with the flow of the gas into the cylinder of the compressor. Very sensible losses in efficiency will be experienced when the springs of both valves are exerting an over-pressure. A very small loss in the volume of gas for each single

or double stroke of a compressor will in twenty-four hours amount to a serious item.

The most effective method for adjusting the tension of the compressor valve springs to a nicety is by the use of the indicator. In

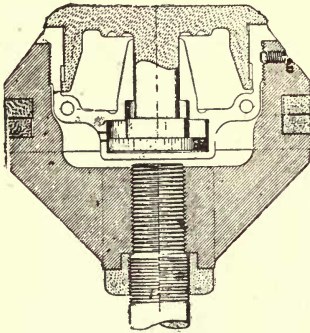

Fig. 161.

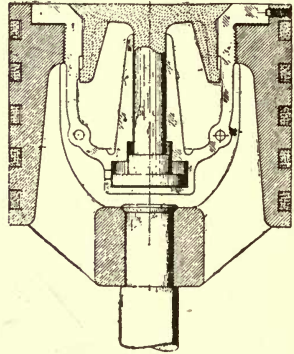

Fig. 162.

Triumph Pattern Suction Valves for Frick Compressors.
Vertical Central Sections.

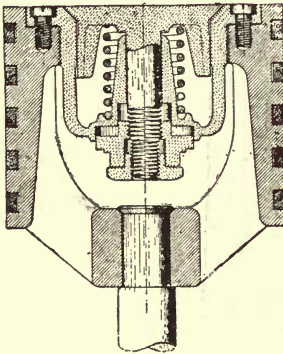

Fig. 163.

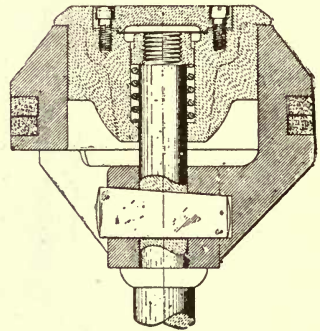

Fig. 164.

Triumph Pattern Suction Valves for De La Vergne Compressors.
Vertical Central Sections.

fact, without the use of the latter instrument, it is impossible to ensure any degree of accuracy of adjustment, and consequently every compressor should be provided with proper pipes to admit of the attachment of an indicator.

Figs. 158 and 159 show respectively the construction of the discharge and suction valve of the Hercules compressor. An obvious objection to the old form of construction was that on the removal of the cap the whole valve would fall into the cylinder. In the improved pattern made by the Triumph Company, this objection is obviated.

Fig. 160 shows the Triumph suction valve. This valve is fitted with a guard so constructed as not to reduce the port area, which guard is attached to the lower end of the valve stem, which is enlarged for this purpose. In case of breakage, or should the stem come loose,

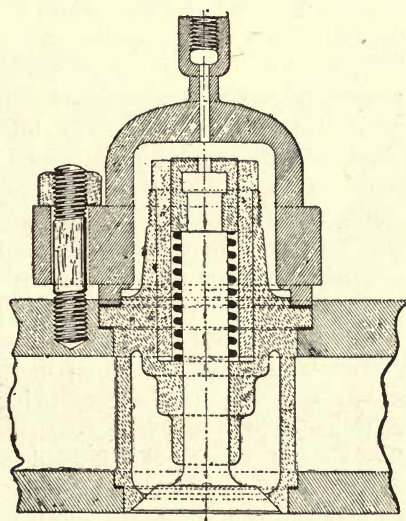

Fig. 165.—Triumph Pattern Valve for Calahan Compressor.
Vertical Central Section.

this guard will prevent the valve from dropping into the cylinder. By removing the hood or cap on the top of this valve, which may be done whilst the machine is in operation, the movement of the stem may be seen. This enables the person in charge to ascertain whether or not the valve is working properly. Should the suction valve become tight from some cause, or the spring be too tight, all that it is necessary to do is to remove the cap, take off the locker and turn the valve-stem to the right. If, on the contrary, the spring is too slack or light, and permits the valve to open too much, the stem should be turned to the left. After the required adjustment the locker and cap can be

replaced and the valve will be found to be working properly. The whole of this operation can be effected without shutting down the machine.

Figs. 161 to 164 show the patterns of safety suction valves constructed by the Triumph Company for the Frick and the De La Vergne types of compressors, and Fig. 165 illustrates the pattern of valve made by the same company for the Calahan type of machine.

PIPE JOINTS AND UNIONS.

An important part of a compression plant is the provision of absolutely gas-tight pipe joints, which, by the way, is by no means an easy matter to effect, at least with the agents working at the higher pressures. It is scarcely necessary to observe that the pipes must be so put up that they will be capable of expanding and contracting freely, for the range of expansion in pipes which are liable to be subjected to extremes of temperatures so widely differing as in the present case, is considerable. The pipes should likewise be fixed in sections, so that any particular portion can be removed for cleaning or repairs and replaced in position without having to interfere with the other ones.

For various reasons it is impracticable to use joints screwed together with white or red lead or varnish, as in the case of steam-pipes, and consequently some other method of forming a gas-tight joint has to be resorted to. A joint which is frequently employed is a compound screwed and soldered one, and this kind of joint is found in practice to be a very durable and reliable one, being capable of withstanding the expansion and contraction to which the pipes are constantly liable, as well as the periodical rapping to which they are subjected during cleansing operations. The leading features of all joints of this description is the commencement of the female screw thread in the socket a short distance from the extremity of the pipe or fitting, the intermediate portion being slightly enlarged so as to form an annular space or clearance, when the spigot end of the pipe is in position, adapted to receive the solder.

A method of forming gas-tight joints, for use wherever the end of a coil or of a pipe is to be secured to the sides or ends of any of the chambers, invented by Pontifex in 1887, is as follows:—A nut is screwed on to the pipe on either side of the plate, and on one or both sides of the plate a circular recess is formed around the pipe. Into this recess, and around the pipe, is inserted a packing

ring or insertion of india-rubber or of any other suitable material, which ring is circular in transverse section. The nut screwing on the pipe is likewise shaped circular at one end so as to enable it to enter and fit into the recess, or in some instances a washer, so formed, or dished or hollowed out, that when forced against the packing ring it will cause it to press inwardly against the pipe, is interposed between the nut and the plate. In this manner a perfectly gas-tight joint, capable of withstanding considerable pressure, is formed, the india-rubber or other packing ring or insertion being firmly held in position so that it cannot escape from the pressure that is put upon it.

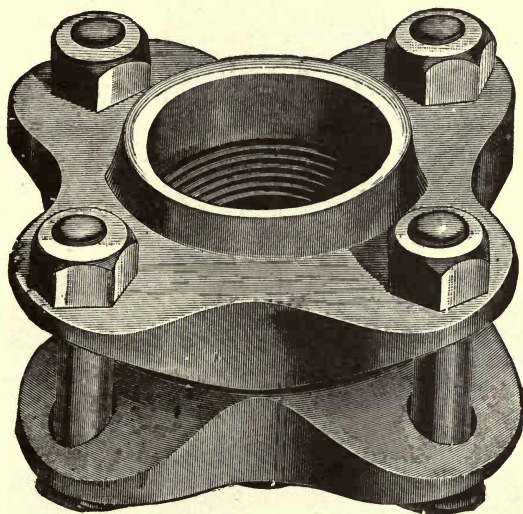

Fig. 166.—De La Vergne Pipe Joint. Perspective View.

Figs. 166 and 167 illustrate, in perspective and vertical central section, the De La Vergne type of pipe joint. To ensure a tight joint to withstand high pressure the flanges are connected to the pipes both by screw threads and solder, the latter being run into the annular recesses or clearances shown above the threaded portions, the surfaces of which are well tinned. The joint between the flanges is formed by an annular projection upon the one fitting into a corresponding groove formed in the other, which, when the nuts are screwed up upon the bolts for connecting the flanges, is pressed home and bears upon a suitable packing ring inserted into the bottom of the corresponding groove or recess, and thus forms a perfectly gas-tight joint. Similar

screwed and soldered joints are likewise employed wherever it is necessary to use a return bend, elbow, tee, cross, or other connecting piece. The fittings are either made of malleable iron or steel.

The result of covering the thread of the pipe with solder, and running the latter into the above-mentioned annular recess or clearance, and thus forming a compound screwed and soldered joint, is, that what is otherwise the weakest part of a length of piping becomes

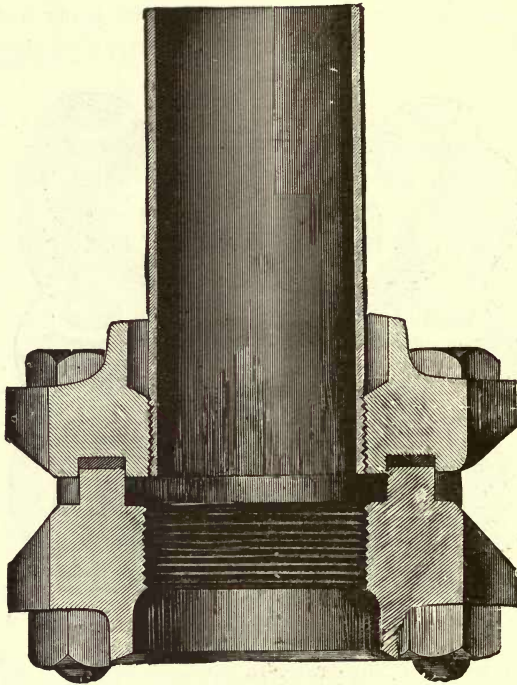

Fig. 167.—De La Vergne Pipe Joint. Vertical Central Section.

the strongest. It is stated by the company that it has been invariably found that when the usually applied test of 1,000 lbs. hydrostatic pressure to the square inch is overrun, the pipe rips open before the joint gives out.

Fig. 168 is a vertical central section illustrating the Kilbourn joint, which is especially intended for use where it is necessary to set tubes or pipes in places where an expander cannot be used, or where sweating or soldering is requisite to make a perfect gas-tight joint adapted to

withstand very high pressures. As will be seen from the illustration the extremity of the pipe is flanged and secured in a recess in the plate by means of a nut or collar, after which solder is run round it. Where the plate is of insufficient thickness to allow for a depression being left for the solder a rib is formed thereon, as shown. In this manner the inventor claims that the pipe or tube can be so secured to a tube plate or its equivalent that it will be perfectly firm and rigid, and that the solder will retain its hold against all ordinary or usual contingencies, whilst at the same time forming a perfectly gas-tight joint. In Fig. 169 is shown the Kilbourn coupling for connecting together different lengths of pipe, or forming joints between the latter and their connections, where fluid-tight joints to withstand very high pressures are demanded. The usual internally screw-threaded socket

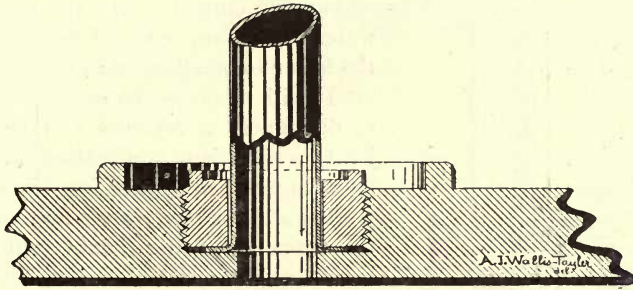

Fig. 168.—Kilbourn Joint for connecting Pipes to Plates.
Vertical Central Section.

is chamfered or bevelled at its extremities, and caps having internally chamfered shoulders and bored to fit over the pipes, and over the socket, are forced against the latter by means of back-nuts, so as to compress the packing rings or jointing materials, placed between the chamfers on the socket and caps, as shown, and thus form a perfectly gas or fluid tight joint.

In forming a screwed and soldered joint (Figs. 166 and 167) of the type above described, owing to the comparatively small amount of surfaces in actual contact and tending to prevent leakage, it is essential that great care should be taken in order to ensure the lasting qualities of the joint, and if these precautions be observed, and the joint be well made, it will remain gas-tight for a considerable number of years. Those portions of both the exterior and interior surfaces of the pipes between which the solder is poured should be

first carefully tinned, this operation being performed just before the formation of the joint, so as to avoid the injury that might otherwise occur to the thin layers of tin, and thus to ensure as perfect surfaces as possible and admit of as firm as practicable an adherence of solder to both of the surfaces to be united.

All grease having been first carefully removed by scraping and washing over with killed or prepared hydrochloric or muriatic acid, the tinning of the faces can be easily performed by means of a soldering iron in the ordinary manner. The killing of the hydrochloric acid is effected by placing in it pieces of zinc until all ebullition ceases, and after cooling, diluting the acid with water in the proportion of two parts of the latter to one part of the former.

It will, of course, be understood that to disconnect a screwed and soldered joint, a sufficient application of heat must be made to melt or fuse the solder.

Figs. 170 to 183 show a few amongst the numerous other joints that have been brought out and used. Fig. 170 is a very substantial pattern of steel flange union or connection, in which a blue-lead gasket is used which is cast to fit into the square groove in the face of one of the flanges, the rib or projection on the opposite flange also fitting into this groove so that when the flanges are drawn together by the four bolts, the lead gasket will be pressed firmly into the groove, the latter preserving the form and thickness of the gasket, and so forming a perfectly gas-tight joint.

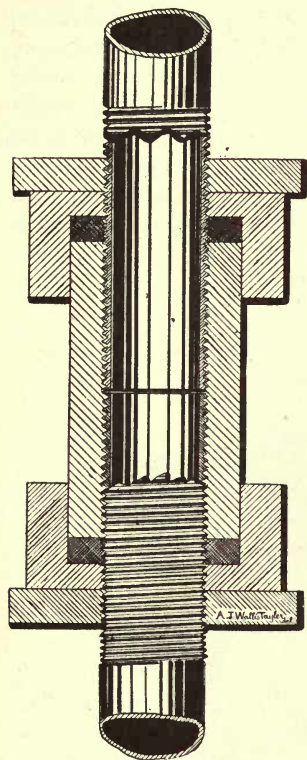

Fig. 169.—Kilbourn Joint for connecting different lengths of Pipes. Vertical Central Section through Joint.

Similar types of unions are also shown in Figs. 171, 172, and 173. The flange union shown in Fig. 174 is intended for a joint made with rubber and gasket, or any sheet packing similar to that used for gas, water, and steam, and the flanges are made of steel.

By reason of the larger surfaces that are in contact, flange joints

formed in the ordinary manner would remain gas-tight for a longer time than would be the case with screwed joints. Ammonia-tight flange joints can be made by the insertion of a common gasket, and with flanges adapted for the use of sheet packing of the kinds used

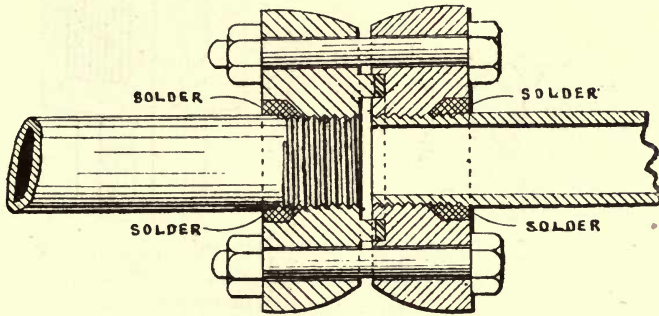
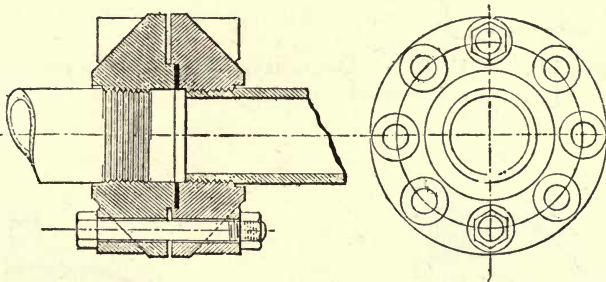

Fig. 170.—Flange Coupling or Union for Lead Gasket.
Vertical Central Section.

for steam and hydraulic joints, but in the latter case it is preferable to employ flanges having on one of their faces a circular raised rib or fillet A, and in the other face a corresponding groove or recess, as shown in Fig. 174.



Figs. 171 and 172.—Frick Coupling or Union for Large Pipes.
Vertical Central Section and End View.

Fig. 175 shows a De La Vergne soldered pipe joint-socket bend or elbow for ammonia pipes. Fig. 176 is a return socket bend. Fig. 177 is a flange bend or elbow for gasket joint. Figs. 178 and 179 is a side view, partly in elevation, and an end view of the Frick evaporating

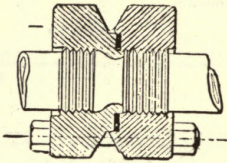

Fig. 173.—Frick Coupling or Union for Small Pipes. Vertical Central Section.

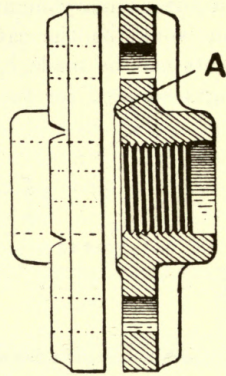

Fig. 174.—Flange Coupling or Union for Sheet Packing. Elevation partly in Central Section.

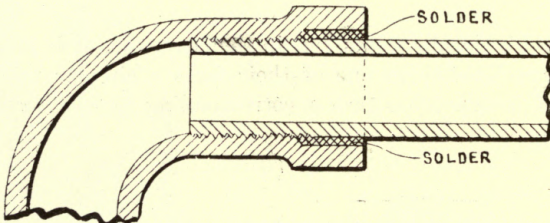

Fig. 175.—De La Vergne Soldered Pipe Joint, Bend, or Elbow. Vertical Central Section.

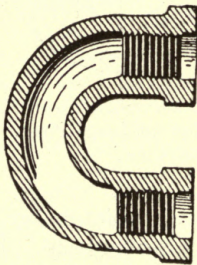

Fig. 176.—Return Socket Bend. Vertical Central Section.

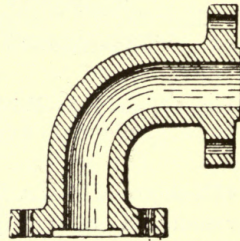
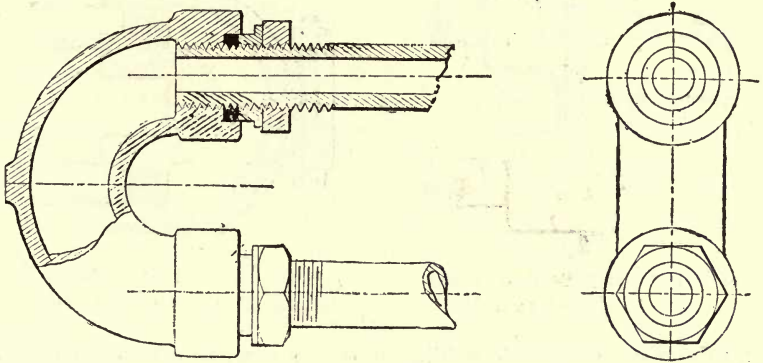

Fig. 177.—Flange Bend or Elbow. Vertical Central Section.

coil bend. Fig. 180 is an end view, and Fig. 181 is a side view of a flange return bend, and Figs. 182 and 183 show, in side elevation and vertical central section, a form of return bend or head formed in



Figs. 178 and 179.—Frick Evaporating Coil Bend. Side View partly in Section and End View.

halves for use in places where it is desired to disconnect any one of the coils of a stack. The pipes are, it will be seen, connected to the head by screwed and soldered joints, and the two halves of the head

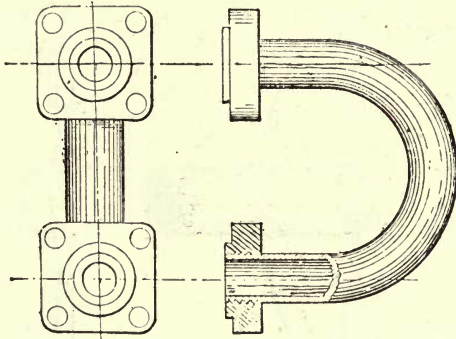

Figs. 180 and 181.—Flange Return Bend. End View and Side View.

are arranged to form an ordinary flange union, a suitable insertion being used to form a gas-tight joint, and two long side bolts (one of which only is shown fully in the illustrations) and a shorter bolt at the

bend serving to clamp them together. The illustrations are for the most part sufficiently clear, and require but little explanation.

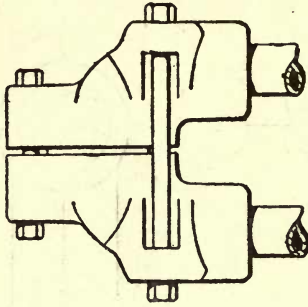

Fig. 182.—Return Bend formed in halves. Side Elevation.

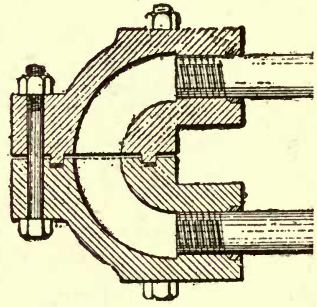
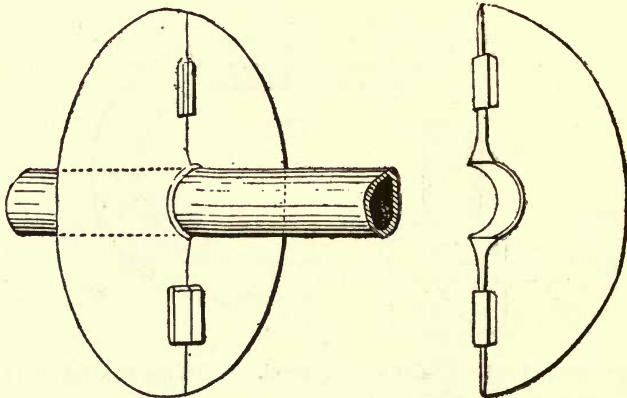

Fig. 183.—Return Bend formed in halves. Vertical Central Section.

By the use of electric welding makers are now enabled to provide long continuous coils of pipe and so for the most part dispense with the use of joints in awkward places.

MEANS FOR INCREASING COOLING SURFACES OF PIPES.

Fig. 184 is a perspective view of a disc or gill which is formed in halves, one of which is shown removed in Fig. 185. The two halves



Figs. 184 and 185.—Discs or Gills for Increasing the Surface of Refrigerating Pipes. View showing Gill fixed in position on Pipe, and View showing one-half of Gill removed.

or parts of the disc are adapted to be secured together upon the pipe by means of iron clips which press them against the pipe. These discs are fixed at regular intervals upon the cooling or refrigerating pipes in the cold stores or chambers, after they are all put up; and, according to the inventors, their effect is to increase the cooling surface to such an extent that only one foot of pipe is found requisite where four would be necessary without them. These removable discs or gills are made by Messrs De La Vergne & Co.

Mr B. Lebrun, of Nimy, Belgium, also makes a pattern of cooling pipe with gills or flanges. These pipes are of cast iron, and the gills or flanges are formed therewith. The Maquet gilled piping is made by Mr H. R. Witting, of 9 Southampton Street, London. Several other arrangements on the same principle have been devised for increasing the surface of cooling or refrigerating pipes.

CHAPTER XII

REFRIGERATION AND COLD STORAGE

Refrigeration by means of the Cold-Air Machine—Refrigeration by means of Compression or Absorption Machines—The Brine Circulation System—The Direct Expansion System—The Cold-Air Blast System—Piping for Cold Stores.

THE knowledge of the conservative action of cold upon organic substances is probably as old as the existence of human beings, and has been constantly utilised to preserve from putrefaction various alimentary substances.

Attempts have for many years been made to produce a refrigerated atmosphere by means of ice, but the results obtained are far from satisfactory, the atmosphere of the stores or chambers so cooled being as a rule saturated with moisture from the melting ice, and the meat preserved therein assuming a more or less musty and disagreeable flavour. The possibility, however, of successfully keeping meat in artificially cooled stores or chambers dates only from the invention of Charles Tellier's machine and brine circulating system in 1873, by which he was enabled to create a cold dry atmosphere, wherein organic substances could be maintained constantly at that temperature which is found to be preservative. Mechanical refrigeration is therefore, it will be seen, an art of comparatively modern origin.

For the preservation of meat, machines working upon the compression system, the absorption system, and cold-air machines are employed.

In freezing carcasses for transportation, the cold is best applied gradually at first, so as to ensure an even freezing throughout, and prevent damage to the inner portions of the meat by the freezing of the external surfaces thereof before the internal heat is sufficiently lowered. When frozen or congealed a temperature of at least as low as 18° Fahr. should be maintained. For cooling ships' holds, cold stores or chambers, and other similar purposes, temperatures varying from 15° to 55° Fahr. are required, in accordance with the material

being dealt with, an even temperature in every part being absolutely necessary. When freezing carcasses they must be hung at such distance apart as to admit of a ready circulation of the cold air round them taking place; for storage for transportation, however, it is recommended to pack them as tightly together as possible, provided no injury through bruising be caused, and that a sufficient clearance or free space be left for the circulation of the cold air between the carcasses and the inner lining of the storage chamber. The temperature of cold land stores or chambers for storing and preserving unfrozen meat need not be lower than 25° Fahr., but should not rise above 30° Fahr. When the meat is frozen, however, as it must be when it has to be kept for any length of time, it may advantageously be maintained at as low a temperature as 15° Fahr.

The atmosphere of cold stores in some instances should be kept as dry as practicable; whilst in others a certain amount of moisture is desirable, as, for instance, when used for preserving fish, eggs, and cheese, which are injured by the air being too dry. For preserving meat for comparatively short periods the best temperature is from 30° to 40° Fahr., as most descriptions are injured to a greater or less extent if permitted to freeze, by the bursting of the vesicles of which flesh is composed. When, however, it is required to be preserved for a longer period than, say, three weeks it is absolutely essential that the meat should be frozen, otherwise a slight decomposition will take place, and it will become greatly deteriorated.

When a cold-air machine is employed for refrigeration, the cold air is, as a rule, admitted to the freezing room, cold storage chamber, or chill room through ducts placed near the ceiling, and after it has done its duty is conducted back again to the compressor, wherein, after being mixed with a sufficient amount of fresh air, it is again compressed.

The most advantageous method of conveying the cold air from the machine to the chill room or cold store or chamber is by means of wooden trunks or conduits discharging into the latter through an inlet situated at or near the ceiling at one extremity thereof, the used or spent air being withdrawn through a similarly situated outlet and conduit at the other extremity. All abrupt rises or falls or bends in the air trunks should be avoided, and their length should not be excessive, as the loss experienced through the rise in temperature of the air in the latter case would be very considerable. The extreme limit of distance to which it is advisable to convey the cold air through these conduits is 200 feet.

When carcasses are to be congealed, the temperature of the freezing chamber or room should be maintained at about 10° Fahr.; as has been already stated, however, the cold should on no account be applied too rapidly at starting, but gradually, so that the internal heat may be first sufficiently reduced, to avoid injury to that portion of the meat, before the outer surface becomes frozen.

For after preservation of frozen meat it is sufficient to keep the atmosphere of the chamber or store down to a temperature of about 15° or 18° Fahr.; it should not, however, be allowed to rise above 20° Fahr.

REFRIGERATION BY MEANS OF COLD-AIR MACHINES.

According to Colonel B. H. Martindale, C.B., R.E., the general manager of the London and St Katherine Dock Co., in 1886 they had fifty-six refrigerating chambers in two vaults, the smallest of which chambers had a cubic content of 2,273 ft., and the largest thereof of 9,280 ft., the total content of the fifty-six chambers being something over 183,000 cub. ft. The carcasses of the sheep averaged in weight 56, 60, and 72 lbs. each; and the whole of the chambers completely filled would contain about 59,000 sheep of the first weight, 56,000 of the second, and 44,000 of the third; in practice, however, a space or clearance had to be left for gangways, and for separating different marks, for which a deduction had to be made from the total storage capacity, and taking the shipments as they chanced to arrive, the above space was equal to the storing of the carcasses of about 44,000 sheep.

The cold-air machines employed in connection with the fifty-six chambers in question comprised four Haslam 60,000 cub. ft. machines, and three Hall 30,000 cub. ft. machines, supplied with steam from three multitubular boilers of the marine type, and four boilers of the locomotive type, the former having been found in practice to be the best. One of the Haslam 60,000 cub. ft. machines worked on fifteen chambers, having a total capacity of 48,000 cub. ft., and capable of storing 11,000 carcasses of sheep averaging in weight 72 lbs. each, but which storage capacity was reduced by gangways, &c., to between 8,000 and 9,000. The engine was kept running twenty hours out of every twenty-four, the stoppage including the time required for clearing the snow from the valves, snow boxes, and air-trunks. The average speed was eighty revolutions per minute, at an air pressure of 44 lbs. per square inch, giving a temperature of -70° in the snow

boxes, and keeping the temperature of the chambers down to from 15° to 18° Fahr., which was found in practice to be about the best temperature to keep the meat at. Better results were obtained in proportion to the fuel consumed, by working at an air pressure of about 44 lbs. per square inch, instead of 50 lbs. and upwards; not giving such a low temperature in the snow boxes, but about -50° Fahr. instead of -60° or -70° , and delivering a larger volume of cold air into the chambers. The proportionate rise in temperature was then much less between the delivery from the expansion cylinder and the distant chambers. Twenty-four chambers, with a capacity of 90,000 cub. ft., were worked by two Haslam 60,000 cub. ft. machines, running at an average of seventy revolutions per minute, with an air pressure of 40 lbs. per square inch, the temperature in the snow box being -55° Fahr.

The atmosphere of the chamber next the machine could, as a rule, be kept at a sufficiently low temperature with but little opening of the delivery ports in the air-trunks, and almost without admitting air at all, as the mere passage of the air-trunks through it kept it nearly cool enough. The greatest care was taken in regulating the delivery and return air-ports or apertures, gradually increasing the area of both in proportion to the increased distance from the machine; the greatest distance to which the cold air was conveyed being 180 ft.

The practical result of the observations taken, which extended over some time, was that the rise of temperature in travelling was 1° Fahr. for every 18 or 20 ft. travelled; but this, of course, must not be taken for more than the result arrived at from general working under existing conditions. It was likewise found that from 1 to $1\frac{1}{2}$ cub. ft. of cold air per hour would keep cool—say at 18° Fahr.—1 cub. ft. of storage at a distance not exceeding 180 ft., or, say, at an average distance of 90 ft. from the machine. The first amount named, viz., 1 cub. ft. of cold air per hour to each cubic foot of storage, was the result arrived at during temperate weather, and this, it is estimated, would most probably be amply sufficient were the chambers fully stored with carcasses, and left entirely undisturbed; but as this is not possible in practice, an allowance has to be made for the opening of doors for the purpose of deliveries and so on; and the second amount, or $1\frac{1}{2}$ cub. ft. of air per hour for every cubic foot of storage that it was desired to keep down to, say, 18° Fahr., was found to be about correct for general practice.

The coal consumption was stated to be for three machines, giving out nominally 120,000 cub. ft. of air (one 60,000 cub. ft. and two

30,000 cub. ft. machines), $4\frac{1}{2}$ tons of coal in twenty hours; and two 60,000 cub. ft. machines, working under practically similar conditions, had a like consumption. The coal used was ordinary Welsh coal, costing about 16s. 6d. per ton.

The London and India Docks Co., when the extensions now in progress are completed, will have refrigerated accommodation capable of receiving 550,000 sheep. The extension consists of twelve cold chambers on three floors.

REFRIGERATION BY MEANS OF COMPRESSION OR ABSORPTION MACHINES.

When refrigerating machines wherein the cooling is effected by the evaporation of a volatile liquid are employed, the refrigeration can be conveniently effected in three ways, viz. :—

First, by cooling a non-congealable salt brine, and then pumping it through a system of pipes, or of open troughs in the chambers. Secondly, by causing a current of air, generated by means of a fan or otherwise, to impinge against surfaces reduced to a low temperature by the expansion of the refrigerating agent itself, or by an internal circulation of cooled brine, and conducting the cold air to the refrigerating chambers. And thirdly, by expanding the gas direct through pipes placed in the chambers.

The main advantage claimed for the first of these plans is that it admits of the machine being stopped, and when an independent brine pump is employed, the brine, wherein a large reserve of cold is stored up, can be continued in circulation for a considerable time before any thawing from rise of temperature and consequently dripping will take place from the pipes.

THE BRINE CIRCULATION SYSTEM.

The agent employed in the brine circulating system consists of a solution of chloride of sodium or common salt* or of chloride of calcium,* chloride of magnesium, or any other suitable solution capable of standing very low temperatures without congealing. To extract or absorb the heat from the brine, the simplest and best method is undoubtedly that most commonly employed, which consists in passing it through a tank of ample dimensions fitted with suitable coils of pipes, through which the chilled liquefied ether, carbonic acid, ammonia, or other volatile refrigerating agent, circulates, vaporises or gasifies, ex-

* For proportions, &c., of these solutions, see p. 532.

pands, and subsequently returns therefrom in the form of a gas or vapour to the compressor, in one system; and in the other, in the form of a strong solution to the generator. An expansion valve or cock, such as one of those illustrated in Figs. 140 to 149 (pages 246 to 252), is fitted to the inlet ends of the submerged coils. The brine, being thus deprived of a large portion of its heat, is then drawn away from this refrigerating or cooling tank or vessel by the brine circulating pump, and is forced through the system of cooling pipes in the refrigerating chamber or cold store.

The arrangement of the cooling pipes in cold stores for preserving provisions of a perishable nature requiring to be kept at various temperatures between 25° and 45° Fahr., in accordance with the description and nature of the provisions, or of those in chambers for freezing or congealing meat and keeping it frozen, which require to be maintained at temperatures of between 10° and 18° Fahr., according to the work demanded, only differ from other installations in the particular disposition and numbers of the pipes, the chambers intended for the latter purpose being, of course, fitted with the greatest number.

THE DIRECT EXPANSION SYSTEM.

When the direct expansion system is in use the pipes should invariably be of wrought iron, and even where the brine circulating system is employed they should preferably also be of the latter material in the case of freezing chambers, as the heat from the chambers passes more readily through the thinner walls of the smaller wrought-iron pipes. Besides which there is, as has been already mentioned elsewhere, a considerable saving of space.

One advantage of this system is that a more economical and rapid cooling is effected than with the brine circulation; another is the simplification of the apparatus and the reduction in the first cost thereof. To counterbalance which advantages, however, there is the danger to human life, of damage to the contents of the refrigerating chambers, and of fire, should any leakage of the gas or vapour from the cooling pipes take place, and also the impossibility of shutting down the machine even for a few minutes without the cooling pipes commencing to drip.

As regards damage to the contents of the rooms or chambers by reason of an escape of the refrigerating agent, however, carbonic acid is known to be non-injurious, and as regards ammonia the fears of any deterioration in the quality of fresh meat which is being frozen or preserved, resulting from any accidental leakage of the pipes, would

seem to be totally groundless, judging from the results of recent practice, and the opinion of experts.

On this head the following extract from an article published in the *Scientific American* in 1889 is of interest :—

“Some years ago Dr B. W. Richardson, in a communication to the Medical Society, called attention to the antiputrescent properties of ammonia, and showed that blood, milk, and other alterable liquids could be preserved for a long time by adding to them certain quantities of solution of ammonia ; and solid substances, such as flesh, by keeping them in closed vessels filled with ammonia gas. Some doubts that would appear to have been raised as to the results reported, on the ground that ammonia was itself a product of decomposition, induced Dr Gottbrecht, of the University of Greifswald, to repeat the experiments with the result of practically confirming all Dr Richardson’s statements. After some preliminary experiments, in which animal matter placed in 5 per cent. of ammonia solution was found free from putrescence after nearly two years, ammonium carbonate was used in place of the free alkali for the sake of convenience. The first experiment made with the washed intestines of freshly killed pigs showed the power of ammonium carbonate to retard putrefaction to be directly dependent upon the concentration of the solution, a 1 per cent. solution retarding it until the third day, a 10 per cent. solution until about the sixtieth day. When added to gelatine in which putrefaction had already been set up by inoculation, it was found that a 5 per cent. solution so modified the conditions that the putrescence ceased, and a 2½ per cent. solution inhibited the development of bacteria, so that the liquefaction of the gelatine was practically stopped. Other experiments showed that in an atmosphere impregnated with ammonium carbonate meat could be kept for six months, and at the end of that time remain nearly unaltered.”

When chambers are refrigerated on the direct expansion system it is nevertheless essential that the system of pipes employed, which can be arranged on any of the plans adopted in the case of brine circulation, should be such as to reduce as far as practicable to a minimum the chance of leakage taking place at the joints, cocks, valves, &c., as, independently altogether of any possible damage to the contents of the stores or chambers, it is highly desirable, for economical reasons, that as little as possible of the circulating agent be lost. Various gas-tight joints have been already briefly described in a previous chapter.

Ammonia, both in a liquid and gaseous condition, has no chemical

effect whatever upon iron, consequently the cooling pipes require no protection except upon the exterior, which should receive a coat of paint every year to prevent them from rusting.

So long, however, as the pipes are coated with snow or ice no corrosion will take place, even externally, as they are thoroughly protected thereby from the oxidising effect of the atmosphere; when, however, they are subjected to alternate freezing and thawing, as is usually the case during actual work, when the chambers or stores are alternately in and out of use, then they must be protected as above mentioned.

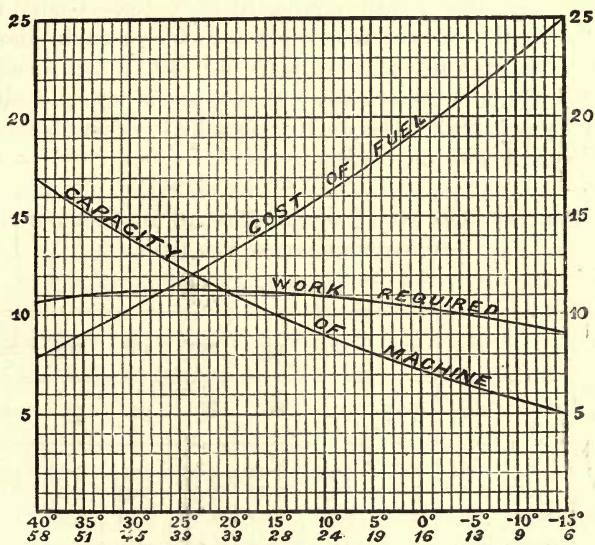

Fig. 186.—Diagram showing the Variation in Capacity, &c., of a Refrigerating Machine.

There is not the least doubt but that the direct expansion system is, as has been before mentioned, more economical than the brine circulation system. This will be obvious when it is remembered that every transmission of heat must of necessity entail a loss of efficiency. A far higher evaporating pressure can be maintained in direct pipes than in evaporating coils in a brine tank, whilst at the same time they have still within them a far lower temperature than in the latter. The result of this is that, in the compression system, the gas is sucked into the compressor at a greater back pressure when direct expansion is

employed, and a far larger amount of efficiency is obtained. The cold, moreover, being produced exactly where it is required, there is practically no waste.

The diagram, Fig. 186, and the following table, show the variations in capacity, &c., of a refrigerating machine, and the economy of direct expansion, as drawn up by the De La Vergne Co.

In the above diagram the line marked "capacity of machine" shows the diminished capacity as the back pressure is reduced. If the machine has a capacity of 10 tons at a return pressure of 28 lbs., as shown by the vertical height of the curve, it has a capacity of 5 tons only with a return pressure of 6 lbs. Under the same circumstances the cost of fuel per ton is increased in the ratio of the vertical heights to the curve marked "cost of fuel," namely, from 14.5 to 25. In other words the cost per ton is nearly doubled while the capacity is halved. The work as seen by the curve marked "work required" diminishes very slowly.

CUBIC FEET OF AMMONIA GAS PER MINUTE TO PRODUCE ONE TON
OF REFRIGERATION PER DAY.

CONDENSER.

| REFRIGERATOR. | <i>p</i> | | 103 | 115 | 127 | 139 | 153 | 168 | 185 | 200 | 218 |
|---------------|----------|----------|------|------|------|------|------|------|------|------|------|
| | <i>p</i> | <i>t</i> | 65° | 70° | 75° | 80° | 85° | 90° | 95° | 100° | 105° |
| | 4 | -20° | 5.84 | 5.9 | 5.96 | 6.03 | 6.06 | 6.6 | 6.23 | 6.30 | 6.43 |
| 6 | -15° | 5.35 | 5.4 | 5.46 | 5.52 | 5.58 | 5.64 | 5.70 | 5.77 | 5.83 | |
| 9 | -10° | 4.66 | 4.73 | 4.76 | 4.81 | 4.86 | 4.91 | 4.97 | 5.05 | 5.08 | |
| 13 | -5° | 4.09 | 4.12 | 4.17 | 4.21 | 4.25 | 4.30 | 4.35 | 4.40 | 4.44 | |
| 16 | 0° | 3.59 | 3.63 | 3.66 | 3.70 | 3.74 | 3.78 | 3.83 | 3.87 | 3.91 | |
| 20 | 5° | 3.20 | 3.24 | 3.27 | 3.30 | 3.34 | 3.38 | 3.41 | 3.45 | 3.49 | |
| 24 | 10° | 2.87 | 2.9 | 2.93 | 2.96 | 2.99 | 3.02 | 3.06 | 3.09 | 3.12 | |
| 28 | 15° | 2.59 | 2.61 | 2.65 | 2.68 | 2.71 | 2.73 | 2.76 | 2.80 | 2.82 | |
| 33 | 20° | 2.31 | 2.34 | 2.36 | 2.38 | 2.41 | 2.44 | 2.46 | 2.49 | 2.51 | |
| 39 | 25° | 2.06 | 2.08 | 2.10 | 2.12 | 2.15 | 2.17 | 2.20 | 2.22 | 2.24 | |
| 45 | 30° | 1.85 | 1.87 | 1.89 | 1.91 | 1.93 | 1.95 | 1.97 | 2.00 | 2.01 | |
| 51 | 35° | 1.70 | 1.72 | 1.74 | 1.76 | 1.77 | 1.79 | 1.81 | 1.83 | 1.85 | |

This shows very plainly the economy of direct expansion. The ammonia in the coils of the brine tank must be cooled below the brine or the directly expanded ammonia. If the difference be 10°, say 5°

instead of 15° , then the capacity of the machine is reduced in the ratio of 10 to 8 or 20 per cent., and the cost for fuel increased in the ratio of from 14.5 to 17.5 or 20 per cent.

These are physical facts which cannot be explained away, and the economy of direct expansion in practice over both brine and air circulation is usually greater than the diagram and table illustrates.

In the brine system, on the other hand, the large refrigerating or cooling tank is exposed to the atmosphere, and even when insulated as perfectly as possible, a considerable amount of heat is unavoidably absorbed, which is, of course, a total loss; considerable fuel consumption is moreover required in the brine circulation system, for the power consumed in pumping the large quantities of brine through the system of pipes in the refrigerating chambers or cold stores, which pipes sometimes run to many thousands of feet in length, and thus give rise to a large amount of friction; and besides, after being in use for some time, they may become internally coated with rust, and with a slimy deposit, which not only produces a considerable increase in the amount of the friction to be overcome in driving the brine through them, but furthermore forms a sort of non-conducting coating, and lessens, to an appreciable extent, the heat-absorbing qualities of the system. Altogether it is not improbable that the entire loss through the additional consumption of fuel entailed from all the above causes does not, in many instances, fall far below 25 per cent. of the entire amount.

COLD-AIR BLAST SYSTEM.

Apparatus is also in use which is so arranged that the refrigerating coils or pipes are placed in a separate compartment connected with the refrigerating chambers or cold stores, and air, having been cooled in the first, is passed into the latter, the circulation being kept up by means of a fan or blower. The refrigerated air is sometimes first washed and freed from snow by passing it through a shower of cold brine, and dried by exposing it to the absorbent action of calcium chloride or other hygroscopic material. This arrangement is possessed of one of the advantages derived from the use of cold-air machines, viz., that every part of the apparatus is situated externally to the refrigerating chamber or cold store, and consequently accessible at all times. Dripping from the refrigerating pipes when the machine is stopped for a short time, and the temperature of the chamber or store rises slightly, is also avoided.

On the other hand, however, there is a considerable loss by reason of the absorption of heat by the cold air on its way from one chamber to the other; an increased consumption of fuel, owing to the power required to work the fan or blower for keeping up the air circulation; and finally the loss of possibly valuable space taken up by the chamber required for the purpose of cooling the air.

The plan wherein air, refrigerated by contact with brine-cooled surfaces, instead of by direct expansion, is passed into the chambers or stores, is evidently still more costly inasmuch as there are not only the losses entailed from the above-mentioned sources, but, furthermore, that caused by another transmission of heat.

PIPING FOR COLD STORES.

AMOUNT OF REFRIGERATION REQUIRED.

The refrigeration required will be governed by the size of the store, the amount of and frequency with which the goods are brought into the store and removed from it, the temperature of the goods, and their specific heat, the mean external temperature, the greater or lesser perfection of the insulation, and various other matters, which render it totally impossible to lay down any hard and fast rules.

A very usual practice is to provide 1 ft. run of 2-in. pipe for every 7 cub. ft. of space contained in the store, but sometimes the proportion used is as much as one to five, whilst again it is occasionally reduced to one to twelve. For refrigerating meat, in which case it is not desirable to cool the exterior too rapidly before the interior has had time to cool to a certain extent, the best proportion to employ is one to ten.

AMOUNT OF REFRIGERATING PIPES NECESSARY FOR CHILLING, STORAGE, AND FREEZING CHAMBERS.

Chilling-Rooms or Chambers, refrigerated on the direct expansion system, 1-ft. run of 2-in. piping for each 14 cub. ft. of space; on the brine-circulation system, 1 ft. run of 2-in. piping for each 8 cub. ft. of space.

Freezing Rooms or Chambers, refrigerated on the direct expansion system, 1-ft. run of 2-in. piping for each 8 cub. ft. of space; on the brine-circulation system, 1-ft. run for each 3 cub. ft. of space.

Storage Rooms or Chambers, refrigerated on the direct expansion

system, 1-ft. run of 2-in. piping for each 45 cub. ft. of space; on the brine-circulation system, 1-ft. run of 2-in. piping for each 15 cub. ft. of space.

EXTREME LIMITS OF CUBIC FEET OF SPACE PER RUNNING FOOT OF 2-IN. PIPING.

These are given in the following table:—

| | | | | |
|---------------------------------------|-----|-----|-----|--------------|
| Breweries.—Medium insulation— | | | | |
| Chip and stock rooms | ... | ... | ... | 1 to 22 |
| Fermenting and settling rooms | ... | ... | ... | 1 „ 22 |
| Packing-rooms | ... | ... | ... | 1 „ 18 |
| Hop-rooms | ... | ... | ... | 1 „ 25 |
| Packing House— | | | | |
| Chill-rooms for beef | ... | ... | ... | 1 „ 12 |
| Hogs | ... | ... | ... | 1 „ 10 |
| Freezing-rooms | ... | ... | ... | 1 „ 6 or 7 |
| Cold Storage— | | | | |
| Cold storage rooms | ... | ... | ... | 1 „ 25 or 30 |
| Cold storage house and freezing-rooms | ... | ... | ... | 1 „ 8 |
| For eggs, brine preferred | ... | ... | ... | 1 „ 12 |
| Cold storage | ... | ... | ... | 1 „ 25 |
| Ice storage | ... | ... | ... | 1 „ 20 |
| Fish freezing (direct expansion) | ... | ... | ... | 1 „ 2 |

CUBIC FEET OF SPACE PER RUNNING FOOT OF 2-IN. PIPE DIRECT EXPANSION.*

| | | | | |
|--|-----|-----|-----|-------------|
| Fermenting and settling rooms | ... | ... | ... | 1 to 20 |
| Packing-rooms | ... | ... | ... | 1 „ 18 |
| Hop-rooms | ... | ... | ... | 1 „ 25 |
| For packing house in chill-rooms for beef | ... | ... | ... | 1 „ 12 |
| The same room for hogs | ... | ... | ... | 1 „ 10 |
| The freezing-rooms | ... | ... | ... | 1 „ 6 or 7 |
| Cold storage rooms | ... | ... | ... | 1 „ 25 „ 30 |
| Under cold storage houses the freezing-rooms | ... | ... | ... | 1 „ 8 |
| Cold storage for eggs | ... | ... | ... | 1 „ 12 |
| General cold storage | ... | ... | ... | 1 „ 25 |
| Ice storage | ... | ... | ... | 1 „ 20 |
| Fish freezing, about | ... | ... | ... | 1 „ 2 |

The following five tables are given by Professor Siebel in the “Compend of Mechanical Refrigeration.”

* Otto Luhr, *American Brewers' Review*,

LINEAL FEET OF 1-IN. PIPING REQUIRED PER CUBIC FOOT OF COLD STORAGE SPACE.

| Size of Building in Cubic Feet, more or less. | Insulation. | TEMPERATURE, DEGREES FAHR. | | | | | |
|---|-----------------|----------------------------|------|------|-------|-------|-------|
| | | 0° | 10° | 20° | 30° | 40° | 50° |
| 100 | Excellent - - - | 3·0 | 1·78 | 0·48 | 0·36 | 0·24 | 0·15 |
| | Poor - - - | 6·0 | 1·50 | 0·90 | 0·66 | 0·48 | 0·30 |
| 1,000 | Excellent - - - | 1·0 | 0·26 | 0·16 | 0·12 | 0·08 | 0·05 |
| | Poor - - - | 2·0 | 0·50 | 0·30 | 0·22 | 0·16 | 0·10 |
| 10,000 | Excellent - - - | 0·61 | 0·16 | 0·10 | 0·075 | 0·055 | 0·035 |
| | Poor - - - | 1·2 | 0·33 | 0·20 | 1·15 | 0·11 | 0·07 |
| 30,000 | Excellent - - - | 0·5 | 0·13 | 0·08 | 0·06 | 0·040 | 0·025 |
| | Poor - - - | 1·0 | 0·25 | 0·15 | 0·11 | 0·03 | 0·05 |
| 100,000 | Excellent - - - | 0·38 | 0·10 | 0·06 | 0·045 | 0·03 | 0·009 |
| | Poor - - - | 0·75 | 0·20 | 0·12 | 0·09 | 0·06 | 0·018 |

NOTE.—The above quantities of pipe refer to direct expansion, and should be made one and one-half times to twice the length for brine circulation. To find the corresponding lengths of 1½-in. pipe divide by 1·25 or multiply by 0·8; of 2-in. pipe divide by 1·08 or multiply by 0·55.

NUMBER OF CUBIC FEET COVERED BY 1 FT. OF 1-IN. IRON PIPE.

| Size of Building in Cubic Feet more or less. | Insulation. | TEMPERATURE, DEGREES FAHR. | | | | | |
|--|-----------------|----------------------------|------|------|------|------|-------|
| | | 0° | 10° | 20° | 30° | 40° | 50° |
| 100 | Excellent - - - | 0·3 | 1·3 | 2·1 | 2·8 | 4·2 | 7·0 |
| | Poor - - - | 0·15 | 0·7 | 1·1 | 1·5 | 2·1 | 3·5 |
| 1,000 | Excellent - - - | 1·0 | 4·0 | 6·0 | 8·4 | 12·4 | 20·0 |
| | Poor - - - | 0·5 | 2·0 | 3·2 | 4·5 | 6·2 | 10·0 |
| 10,000 | Excellent - - - | 1·7 | 6·0 | 10·0 | 13·0 | 18·0 | 28·0 |
| | Poor - - - | 0·85 | 3·0 | 5·0 | 6·5 | 9·0 | 14·0 |
| 30,000 | Excellent - - - | 2·0 | 8·0 | 14·0 | 18·0 | 25·0 | 40·0 |
| | Poor - - - | 1·0 | 4·0 | 7·0 | 9·0 | 13·0 | 20·0 |
| 100,000 | Excellent - - - | 2·6 | 10·0 | 17·0 | 22·0 | 33·0 | 110·0 |
| | Poor - - - | 1·3 | 5·0 | 8·5 | 11·0 | 17·0 | 55·0 |

NOTE.—The above figures refer to direct expansion: from one-half to two-thirds of the spaces only would be covered by the same amount of pipe in case of brine circulation. To find the corresponding amounts of cubic feet of space which would be covered by one lineal foot of 1½-in. pipe, multiply by 1·25 or divide by 0·8; of 2-in. pipe, multiply by 1·08 or divide by 0·55.

NUMBER OF CUBIC FEET COVERED BY 1-TON REFRIGERATING CAPACITY FOR TWENTY-FOUR HOURS.

| Size of Building in Cubic Feet more or less. | Insulation. | TEMPERATURE, DEGREES FAHR. | | | | | |
|--|-----------------|----------------------------|-------|-------|--------|--------|--------|
| | | 0° | 10° | 20° | 30° | 40° | 50° |
| 100 | Excellent - - - | 150 | 600 | 800 | 1,000 | 1,600 | 3,000 |
| | Poor - - - | 70 | 300 | 400 | 600 | 900 | 2,000 |
| 1,000 | Excellent - - - | 500 | 2,500 | 3,000 | 4,000 | 6,000 | 12,000 |
| | Poor - - - | 250 | 1,500 | 1,800 | 2,500 | 5,000 | 10,000 |
| 10,000 | Excellent - - - | 700 | 3,000 | 4,000 | 6,000 | 9,000 | 18,000 |
| | Poor - - - | 300 | 1,800 | 2,500 | 3,500 | 7,000 | 14,000 |
| 30,000 | Excellent - - - | 1,000 | 5,000 | 6,000 | 8,000 | 13,000 | 25,000 |
| | Poor - - - | 500 | 3,000 | 3,500 | 5,000 | 11,000 | 20,000 |
| 100,000 | Excellent - - - | 1,500 | 7,500 | 9,000 | 14,000 | 20,000 | 40,000 |
| | Poor - - - | 800 | 4,500 | 5,000 | 8,000 | 16,000 | 35,000 |

REFRIGERATING CAPACITY IN B.T.U. REQUIRED PER CUBIC FOOT OF STORAGE ROOM IN TWENTY-FOUR HOURS.

| Size of Building in Cubic Feet, more or less. | Insulation. | TEMPERATURE, DEGREES FAHR. | | | | | |
|---|-----------------|----------------------------|-----|-----|-----|-----|-----|
| | | 0° | 10° | 20° | 30° | 40° | 50° |
| 100 | Excellent - - - | 1,800 | 480 | 360 | 284 | 180 | 95 |
| | Poor - - - | 4,000 | 960 | 480 | 470 | 330 | 140 |
| 1,000 | Excellent - - - | 550 | 110 | 95 | 70 | 47 | 24 |
| | Poor - - - | 1,100 | 190 | 165 | 110 | 55 | 28 |
| 10,000 | Excellent - - - | 400 | 95 | 70 | 47 | 30 | 16 |
| | Poor - - - | 900 | 160 | 110 | 81 | 40 | 20 |
| 30,000 | Excellent - - - | 280 | 55 | 47 | 35 | 22 | 11 |
| | Poor - - - | 550 | 95 | 81 | 55 | 26 | 14 |
| 100,000 | Excellent - - - | 190 | 38 | 30 | 20 | 14 | 7 |
| | Poor - - - | 350 | 63 | 55 | 35 | 18 | 4 |

CHAPTER XIII

REFRIGERATION AND COLD STORAGE (*continued*)

The Construction and Arrangement of Cold Stores and of Cold Storage Rooms or Chambers—Ventilation—Air Circulation—Insulation—Railway Vans.

It is completely beyond the scope of this work to deal with the architectural aspects of the requisite buildings, and, besides, these latter have, as a general rule, to be adapted to the special requirements of each particular case. All that is here contemplated, therefore, is to make a few observations upon the internal arrangement, premising that wherever possible it is advantageous to arrange for the delivery to and from the store being made from the uppermost storey. The reason for this is obvious, cold air, being heavier than warm air, has a tendency to sink to the lowest level, little or no danger exists, therefore, of its escaping from above, whilst, on the contrary, by reason of its weight, it would naturally be forced out of any open door or window placed at a lower level. The possible penetration of heat from the exterior to the interior of the store is also greatly reduced.

Failing this plan, all the rooms or chambers in a cold store should be arranged to open into a well-insulated corridor, or, in the case of a single cold storage room or chamber, into a porch, lobby, or ante-chamber, by which means the penetration of heat from the exterior into the room or chamber when it has to be entered to place provisions therein, or to remove them therefrom, is lessened.

COLD ROOMS OR CHAMBERS.

A most important feature in the internal construction of a cold store is the insulation, and to this subject it is intended to revert at some length later on in a special section of this chapter.

At the Southampton Docks four cold stores or chambers, having a joint capacity of 47,000 cub. ft., are refrigerated on the direct expansion system by a 6-in. by 12-in. double-acting De La Vergne machine having two compressors driven by a 10 H.P. gas engine. The

proper insulation of the stores or chambers has been very carefully attended to, and a few hours' working out of every twenty-four is stated to maintain the temperatures sufficiently low.

The ducts or inlets for the admission of the cold air into the store or chamber when the refrigeration is effected by means of a cold-air machine, or by air reduced in temperature in a separate chamber as before described, are frequently placed as close to the roof or ceiling of the room, whether land or marine, as can conveniently be done, this having been stated to have been found in practice to be the most advantageous position, and the cold air having performed its work is drawn off at outlets also situated in this position. It is very doubtful, however, whether this is the most advantageous arrangement, and this subject will be further discussed later on.

In packing carcasses in a cold store or chamber, they should be placed as close together as possible, taking care, however, to leave a free space or clearance between them and the inner lining of the room, through which the cold air can freely circulate.

When hanging frozen mutton before cooking, care must be taken that it is so placed that the juice will not run out of the cut end. For example, hind-quarters, haunches, and legs must be invariably hung with the knuckle-end downwards; and loins and saddles by the flaps, so as to give them a horizontal position. The cut end, moreover, should always be presented to the fire first when cooking, thereby sealing it and preventing the gravy from escaping from the joint. Frozen lamb does not need any preliminary hanging, but can be cooked as soon as thawed.

As regards the capacity of a machine required for the refrigeration of a cold store or chamber of any given dimensions, it would be obviously impossible, in view of the constantly varying circumstances of each individual case, to lay down any hard-and-fast rules. It will have to be separately estimated for each particular installation, in accordance with the amount of cooling work which is necessary, and which it is desired to perform upon the material enclosed in the cold store or chamber, and by the amount of heat that is calculated to pass into the latter from the outside, through the walls, floor, and roof. It will consequently be thus seen that the capacity of the apparatus will depend upon the lowest internal and the highest external temperature, the area of the walls, floor, and ceiling, and also to a great extent upon their construction being carried out in a manner more or less impervious to heat.

Approximate allowance per ton of refrigeration is six beeves of

from 600 to 700 lbs. each; ten to twenty hogs. One thousand cubic ft. of space per ton for small machines up to 2 tons; 4,000 cub. ft. of space per ton for machines from 10 to 15 tons; and 10,000 cub. ft. of space per ton for larger machines used for general purposes. One thousand gallons of sweet water per ton from 70° to 40°. These figures will be of course affected by climate, construction and exposure of buildings, insulation, and management.

As a general rule, however, it will be found that, owing to the circulation of the air, and the radiation through the floor, walls, and roof of the chamber, the cubical contents of the air in the latter will require to be cooled from eight to fifteen times in every hour, in order to ensure the temperature being assimilated to that of the air or gas passing out of the machine.

The following particulars regarding the radiation through walls, &c., are given by Professor Siebel: * "If the number of square feet contained in a wall, ceiling, floor, or window be f , the number of units of refrigeration R that must be supplied in twenty-four hours to offset the radiation of such wall, ceiling, or floor, may be found by the formula:—

$$R = fn(t - t_1) \text{ B.T. units,}$$

or expressed in tons of refrigeration—

$$R = \frac{fn(t - t_1)}{284000} \text{ tons,}$$

In these formulæ t and t_1 are the temperatures on each side of the wall, and n the number of B.T. units of heat transmitted per square foot of such surface for a difference of 1° Fahr. between temperature on each side of the wall in twenty-four hours. The factor n varies with the construction of the wall, ceiling, or flooring, from 1 to 5."

For single windows the factor n may be taken at 12, and for double windows at 7 (*Box*).

For different materials one foot thick the following values are given for n :—

| | | | |
|-----------------------|------------|-----------------------|------------|
| For pine wood - - | 2.0 B.T.U. | For sawdust - - | 1.1 B.T.U. |
| „ mineral wool - - | 1.6 „ | „ charcoal, powdered | 1.3 „ |
| „ granulated cork - - | 1.3 „ | „ cotton - - | 0.7 „ |
| „ wood ashes - - | 1.0 „ | „ soft paper felt - - | 0.5 „ |

* "Compend of Mechanical Refrigeration." Chicago: H. S. Rich & Co., 1899.

For brick walls of different thicknesses the factor n may be taken as follows after *Box* :—

| | | | | | |
|---------------------|--------------------------|---|---|---|-----------------------|
| $\frac{1}{2}$ brick | $4\frac{1}{2}$ in. thick | - | - | - | $n = 5.5$ B.T. units. |
| 1 | 9 | „ | „ | „ | $= 4.5$ „ |
| $1\frac{1}{2}$ | 14 | „ | „ | „ | $= 3.6$ „ |
| 2 | 18 | „ | „ | „ | $= 3.0$ „ |
| 3 | 27 | „ | „ | „ | $= 2.6$ „ |
| 4 | 36 | „ | „ | „ | $= 2.2$ „ |

For walls of masonry of different thicknesses the factor n may be taken as follows after *Box* :—

| | | | | | |
|-------------|-------------|---|---|---|-----------------------|
| Stone walls | 6 in. thick | - | - | - | $n = 6.2$ B.T. units. |
| „ | 12 | „ | „ | „ | $= 5.5$ „ |
| „ | 18 | „ | „ | „ | $= 5.0$ „ |
| „ | 24 | „ | „ | „ | $= 4.5$ „ |
| „ | 30 | „ | „ | „ | $= 4.3$ „ |
| „ | 36 | „ | „ | „ | $= 4.1$ „ |

German authorities give values for n which are less than one-half of the values here quoted.

For air-tight double floors of wood properly filled underneath so that the atmosphere is excluded, and for ceilings of like construction, n is equal to about 2 B.T.U. An air space sealed off hermetically between two walls has the average temperature of the outside and inside air, hence its great additional insulating capacity. If the air space is hermetically sealed inside and outside, it appears that its thickness is immaterial; half-an-inch is as good as three inches.

If a wall is constructed of different materials having different known values for n , viz., n_1, n_2, n_3 &c., and the respective thicknesses in feet d_1, d_2, d_3 , the value n for such a compound wall may be found after the formula of Wolpert, viz. :—

$$N = \frac{1}{\frac{d_1}{n_1} + \frac{d_2}{n_2} + \frac{d_3}{n_3}}$$

In case of an air space perfectly sealed off the factor n may be determined for that portion of the wall between the air space and the outside, which value is then inserted into the formula—

$$R = f n (t - t_1).$$

But in this case while t_1 stands for the maximum outside temperature, t stands for the temperature of the air space, which may be averaged

from the inside and outside temperature, taking into consideration the conductivity and thickness of the component parts of the wall.

Fig. 187 is a vertical section through the end of a refrigerating

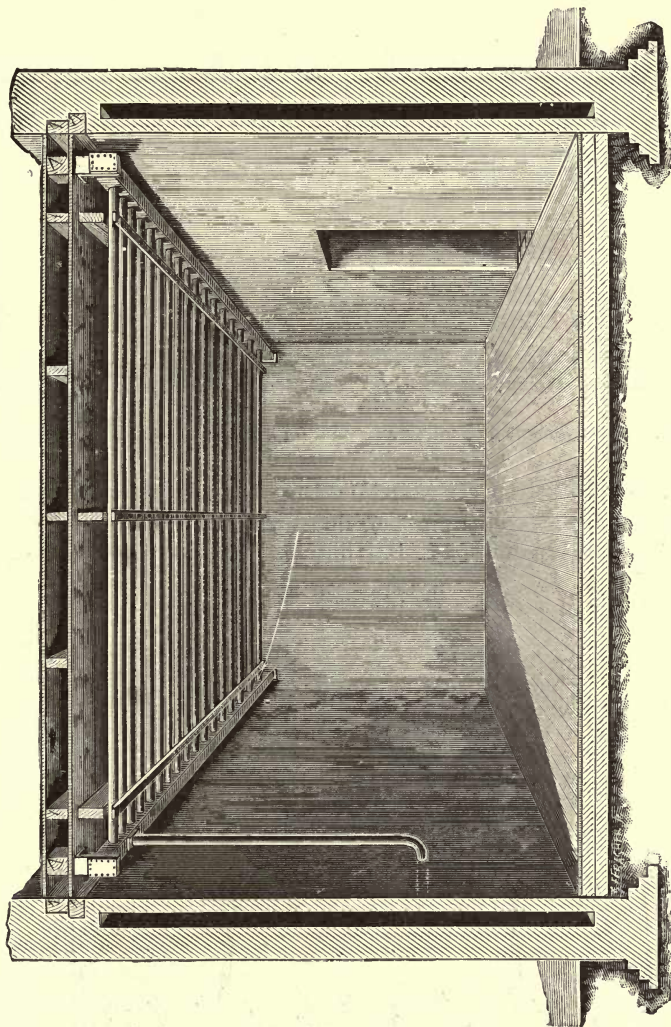

Fig. 187.—Arrangement of Cooling Pipes in Refrigerating Chamber. Transverse Section.

chamber as designed by the Pulsometer Engineering Co., Ltd., showing an arrangement of cooling pipes on the brine circulation system. The pipes are of galvanised wrought iron, which, being very

much lighter and thinner than those formed of cast iron, ensure the maximum amount of head room, and thereby enable a considerable amount of space to be economised.

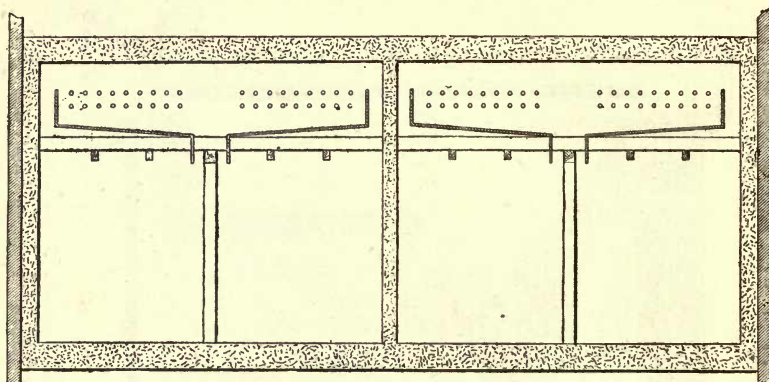

Fig. 188.—Arrangement of Cooling Pipes in Ceiling Lofts. Transverse Section.

Fig. 188 is a transverse section through cold storage rooms or chambers with the cooling pipes arranged in ceiling lofts.

In the British patent of F. B. Hill, No. 16,253 of 1889, is described

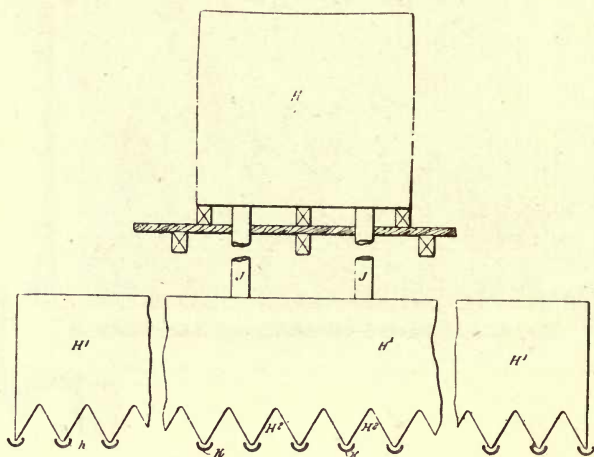

Fig. 189.—Hill's Arrangement for Refrigerating Cold Rooms or Chambers. Diagrammatical View.

an arrangement in which the refrigerating apparatus, shown in Fig. 189, is located on a floor above the cooling chamber. This arrangement, moreover, permits the circulation of the cooling medium by gravity, so that the use of pumps or other machinery for effecting such circulation can be dispensed with. H is the refrigerator tank; H^1 is another tank or vessel which is preferably arranged at a lower

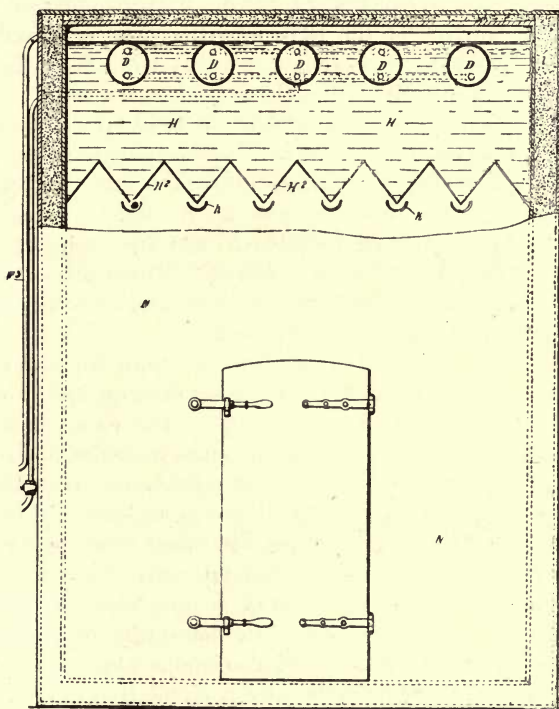

Fig. 190.—Hill's Arrangement for Refrigerating Cold Rooms or Chambers.
Elevation of Chamber partly in Vertical Section.

level than the refrigerator tank, and is connected therewith by means of pipes J in such a manner that a constant circulation of the brine or other non-congealable liquid from one tank to the other will be maintained by gravity during the refrigeration of the liquid.

It was stated by the inventor that, by the use of tanks connected in this manner, the reservoir or store of cold is greatly increased. The

bottom of the cooling tank Π may, if desired, serve as the top or ceiling of the chamber to be cooled, as shown in Fig. 190.

The bottom of the tank Π is formed with a series of V-shaped portions or corrugations Π^2 , and suitable gutters or channels κ are arranged beneath the tank, so that any moisture collecting on the underside will flow to the lower edges of the corrugations or V-shaped portions, and will fall into the gutters or channels, whereby it will be conducted away to any convenient place. The dripping of moisture from the under surface of the tank into the room or chamber to be cooled is thus avoided. This arrangement also increases the area of cooling surface and the strength of the bottom of the tank.

In a later patent, viz., No. 20,509 of 1890, the same inventor describes means for removing snow or hoar-frost from the refrigerating surfaces used for cooling air, which consists in the employment of rotating screw-blades or conveyors, or of annular or other suitable scrapers, or brushes arranged to move to and fro, or up or down, in contact with the surfaces to be cleared. These screw conveyors, scrapers, or brushes are placed within or outside, or both within and outside, the refrigerating tubes or chambers.

F. N. Mackay, No. 16,745 of 1886, provides for the combined utilisation of cold air from an air expansion machine and brine cooled by an absorption or compression machine. The rooms or chambers are partly cooled by the cold air, and the brine from the latter machine is circulated through an arrangement of pipes in the cooling chamber, to which brine pipes corrugated metal sheets are attached to increase the refrigerating effect. Or the corrugated metal sheets may be formed into narrow chambers to receive the brine directly.

To increase the effective surface of cooling pipes F. S. Thomas, No. 2,568 of 1888, forms them with four concavities, or approximately star-shaped in transverse section, and also employs lugs or ribs.

A plan of chilling and freezing by a circulation of cold brine on the wall system has been patented by Hall. In this arrangement the congealing or freezing room or chamber is fitted with parallel hollow or cellular walls constructed of steel or iron plates, and situated at short intervals apart. The carcasses to be chilled or frozen are hung in the spaces or passages left between these walls, which latter can be maintained at a very low temperature by the cold brine circulating there through. An advantage possessed by this method is that, owing to the extensive surfaces afforded by these hollow or cellular walls or plates, an intense cold can be rapidly produced, and the heat very expeditiously abstracted from the carcasses, which are thus quickly

frozen or congealed. On this account, as the space taken up by the hollow walls is so trifling as not to necessitate any increase in the dimensions of the freezing chamber for a given number of carcasses, the proportion usually allotted to the latter may be reduced, and a saving of labour and of depreciation through handling is also effected. The carcasses when frozen are at once removed to cold stores or chambers kept at a proper temperature for preserving the contents, by a circulation of brine through a system of pipes arranged near the ceiling; or air, cooled in the machine-room, may be circulated through the chambers for a like purpose.

On the other hand, these hollow or cellular walls are apparently open to the objections that they are somewhat more difficult to maintain tight and free from leakage than a system of pipes. The shallow space left between the walls would also seem to be liable to become choked by any foreign matter in the brine, and from deposits from the latter; this, however, is said not to be found to be the case in practice with brine circulation, and the arrangement is not suitable, or intended, for the direct expansion system.

In order to facilitate and hasten the operation of chilling and freezing, and lessen the handling to which it is necessary to subject the carcasses, an arrangement for slowly traversing the latter through the freezing or congealing chamber or room has also been devised by the same inventor, wherein an endless chain provided with hooks at proper intervals for hanging the carcasses, and operated by suitable gearing, is provided.

Fig. 191 shows a cold storage room or chamber designed by Mr W. O. Williamson, and patented in 1909. Brine from trays located in the upper part of the room and containing ice and salt in baskets flows successively through tanks arranged round the sides and ends of the room, and from the last tank to a space between trays arranged on the floor, finally being discharged through a suitable pipe. The pipes conveying the brine from the upper trays to the tanks

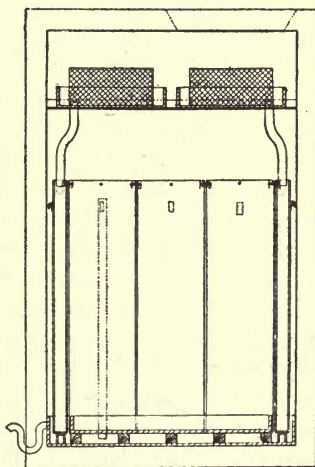

Fig. 191.—Williamson's Patent Cold Storage Chamber.

are so arranged that a certain amount of brine always remains in the trays.

A patent was taken out at the beginning of the year 1895 by Sir A. S. Haslam for an improved apparatus for cooling air to be circulated through cold storage rooms. The main feature of this invention consists in the provision of an air-cooler or chamber, wherein the air or other gas to be cooled is carried between a number of fixed vertical metal plates, down which cold brine or other uncongealable liquid is constantly caused to flow. These plates or diaphragms are as shown in the plan, Fig. 192, which illustrates an arrangement for use in connection with a meat chamber, preferably of a corrugated form, and their lower extremities are placed either in or above a receiver for the liquid which trickles down their surfaces.

To maintain the plates or diaphragms at suitable distances apart, and parallel one with the other, distance-pieces or blocks are placed between them at the top and bottom, which distance-pieces have lugs or recesses on their sides to provide passages for the liquid. The tops of the upper distance-pieces form the bottom of a tank supplied with the cold liquid, and from which it flows down the plates in thin streams; and they have, moreover, vertical projections at each end, which together form the ends of the tank. Above this tank are situated suitable numbers of troughs or pipes, and a shower of brine at a low temperature, drawn or lifted from the receiver below, in which it is cooled by a pump or otherwise, is distributed over the bottom of the upper tank, from whence it trickles down the surfaces of the corrugated or other plates, or diaphragms. Through the spaces or clearances provided between these plates a current of air is driven by means of a fan or blower, the blast being divided by the corrugated plates into a number of thin sinuous currents, and being reduced to a very low temperature by impinging against their surfaces and the cold fluid trickling down their sides. It has been found in practice to be preferable to place the above-described plates or diaphragms as close together as can possibly be done without injuriously checking the flow of air.

Flat plates, or plates with horizontal corrugations, are not found to be so advantageous, because the air can pass between them in a straight line, instead of being compelled to wind backwards and forwards between the corrugations and impinge again and again against the cold liquid and the surfaces of the plates; in the case of flat plates, moreover, they have to be much thicker in order to ensure the requisite stiffness.

This cooling battery is said to have given very favourable results under most exhaustive practical tests.

Another arrangement for cooling air for circulation through cold

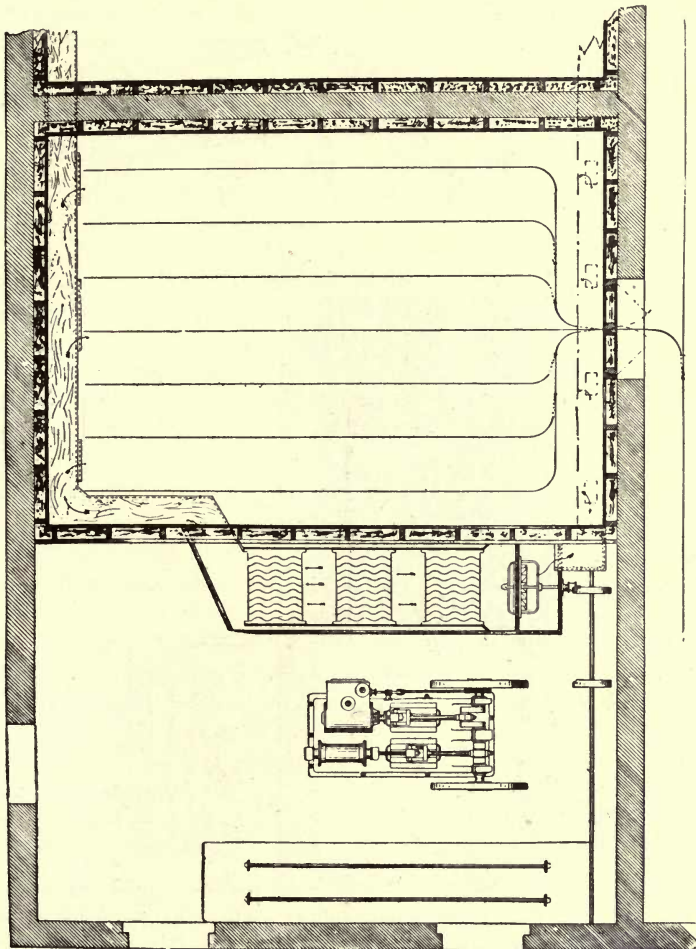

Fig. 192.—Haslam's Patent Brine-Cooling Battery, for Cooling Air to be circulated through Cold Storage Rooms. Plan View.

storage rooms, which was patented in the latter end of the year 1900 by Mr T. Douglas, is shown in vertical central section in Fig. 193. The construction of the apparatus is almost sufficiently apparent from the drawing. It consists briefly of a cylindrical or other tower or

receptacle suitably insulated and having a chamber charged or filled with coke broken up into pieces of suitable dimensions. Above this charge of coke is provided a rose spraying apparatus by which cold brine from the evaporator or refrigerator of the machine is distributed

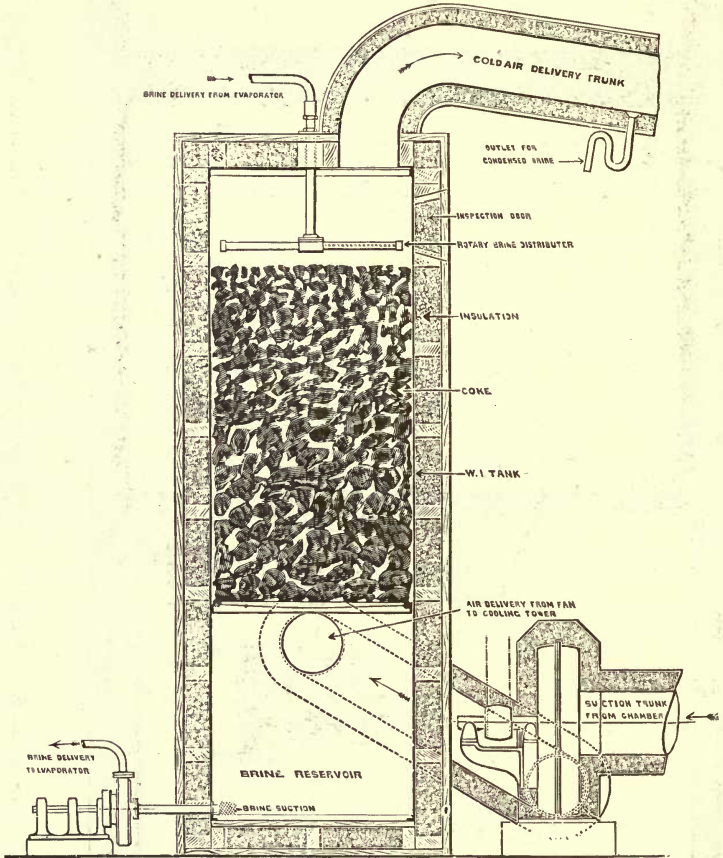

Fig. 193.—Douglas' Patent Apparatus for Cooling Air for use in Cold Storage Rooms or Chambers. Vertical Central Section.

over the coke and trickles down over the same to a brine reservoir in the bottom of the tower, from which it is pumped back to the evaporator or refrigerator. The air to be cooled is forced into the bottom of the tower by means of a suitable fan, and up through the

coke to a cold-air delivery trunk through which it is conducted to the cold storage chamber.

A series of tests carried out with an air-cooling apparatus of this description at Messrs Wm. Douglas & Son's, Ltd., works, Putney, showed a high degree of efficiency, and gave in every case a remarkable approximation between the temperature of the air at the exit from the cooler and that of the brine return to the evaporator. This approximation became closer, when the refrigerating machine was shut down, as the temperatures of both the brine and the air rose, and proved that the coke was an excellent medium for bringing the air into contact with a very large surface of cold brine and thus extracting the maximum of heat from the air. A suitable spray trap can be provided in the cold-air delivery trunk, or other means adopted for drying the air. The brine can be kept up to a proper density by either periodical concentration, or by running out the surplus brine and strengthening the remainder.

An advantage possessed by this apparatus is its relative cheapness, and it can also be readily modified in design to suit different requirements. For instance it may be elevated above the level of the evaporator or refrigerator so that the brine will return to the latter by gravitation, or where this is not possible it may be connected to a brine storage tank, from which the brine can be pumped back to the evaporator, or the foot of the tower may be made into a brine storage tank as shown in the illustration. The evaporating coils may be placed in the lower part of the tower, thus combining air-cooler and evaporator in one apparatus. In cases where height is not available two or more towers may be placed alongside, or a horizontal tower may be formed with diaphragms dividing the coke.

Other arrangements for cooling air by direct contact with cold brine are the use of rotating discs dipping in the cold brine, sacking or canvas saturated with cold brine, &c. Attempts have also been made to draw or force air through a body of cold brine, but this latter method does not appear to have proved a practical success.

In Fig. 194 is shown in vertical central section an arrangement designed by Mr Madison Cooper for washing, cooling, and drying air, more especially for use in cold storage rooms for eggs. This apparatus consists of three parts, viz., first, an air-washing tank, in which the air is caused to flow upwards against a rain of water from a perforated diaphragm above. This not only cools the air to the temperature of the water, say 55° or 60° Fahr., but it also takes out a large portion of the impurities of various kinds. From

this washing tank the air is passed on in a comparatively pure and cool state to be still further reduced in temperature. This latter operation is performed in the second part of the apparatus, which consists of a cooling tank having brine-cooled or direct expansion pipes by contact with which the air is reduced to a temperature several degrees lower than that of the storage room or chamber. This cooling removes the greater portion of the moisture which holds in suspension the few impurities which may have passed the washing tank, the moisture being deposited on the frozen surfaces within the cooler. From the cooler the cold purified air is passed into the

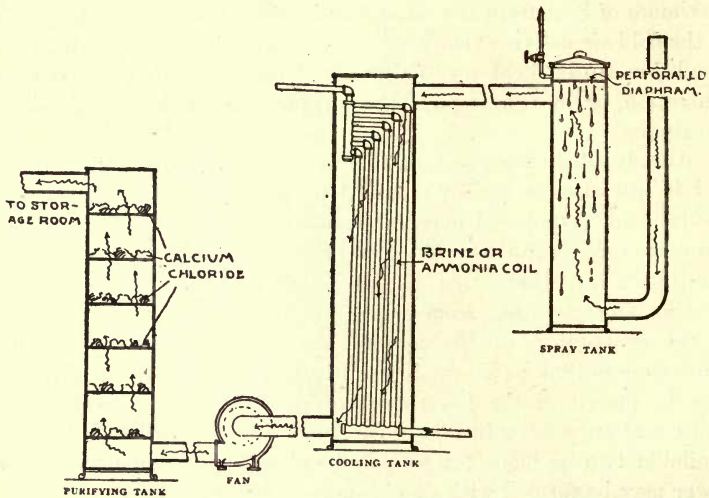

Fig. 194.—Cooper's Apparatus for Washing, Cooling, and Drying Air for use in Cold Storage Rooms or Chambers. Diagrammatical View.

third part of the apparatus or drying-box, which contains chloride of calcium. In this dryer any moisture that may be carried over from the cooler is taken up or absorbed by the chloride of calcium, which is a well-known hygroscopic or deliquescent substance.

Fig. 195 shows in transverse section a beef chill-room fitted with the De La Vergne patent pipe system, a description of which has been already given in a previous chapter. The pipes are, it will be seen, in this instance arranged at the sides and at the centre of the chill-room, and drip-trays or troughs are provided to catch and carry off any

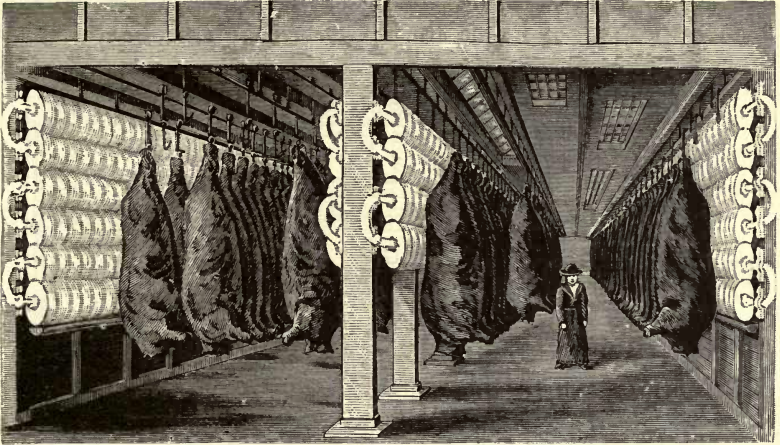

Fig. 195.—Arrangement of Cooling Pipes in a Beef Chill-room, fitted with the De La Vergne Patent Pipe System. Transverse Section.

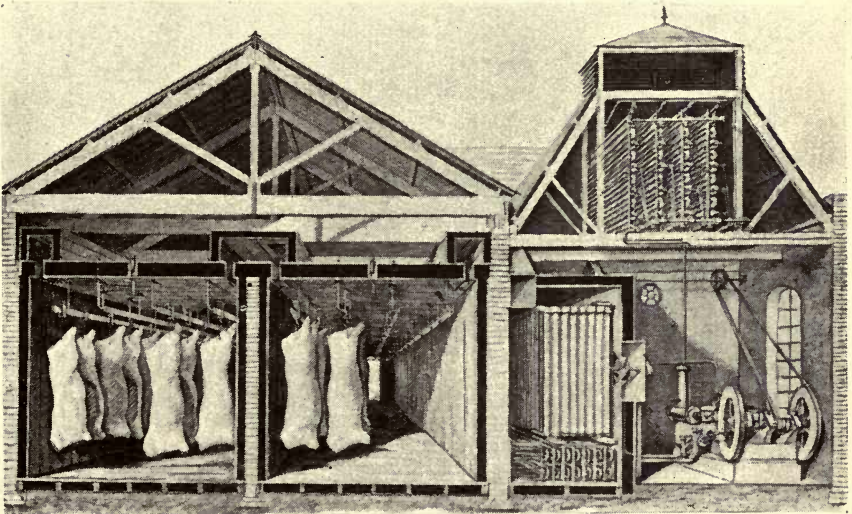

Fig. 196.—Beef Chill-rooms in Cold Store, fitted with Haslam Patent Brine-Cooling Battery. Transverse Section.

water falling from the cooling pipes, upon the exterior surfaces of which the moisture present in the atmosphere of the room or chamber be-

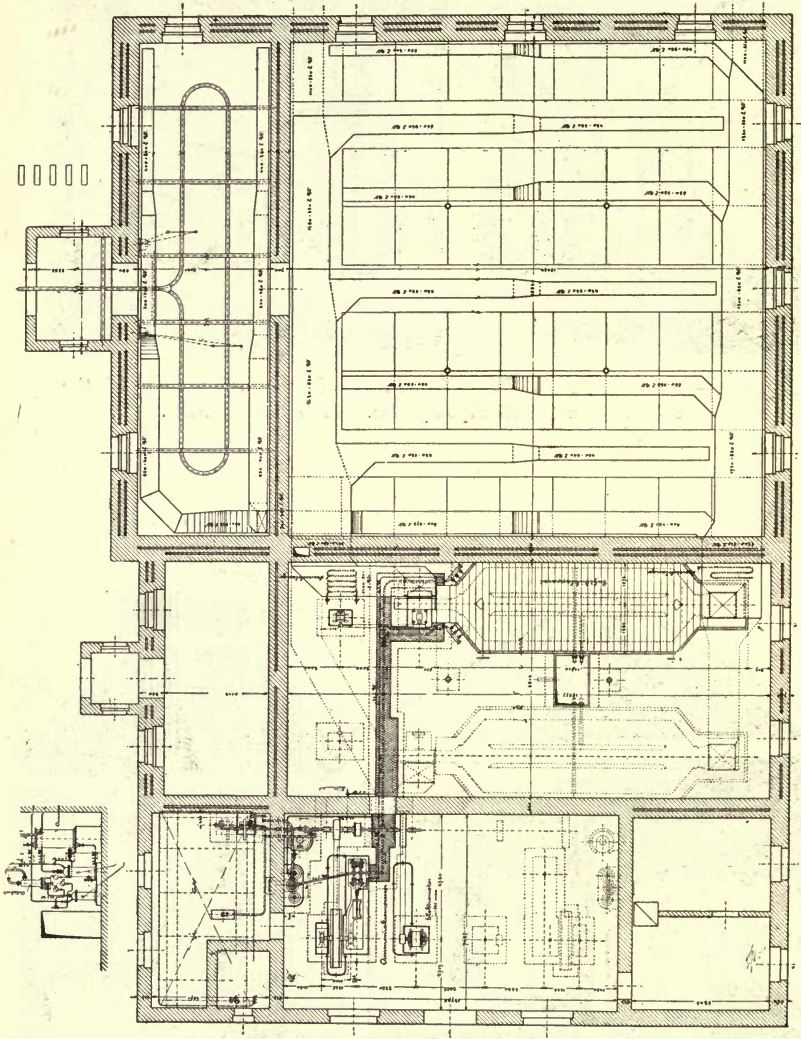

Fig. 197.—Refrigerating Installation on the Humboldt System, erected at Municipal Abattoir, Riga. Plan.

comes condensed, either in the form of water or of hoar frost. In the latter case dripping is liable to commence on any rise of temperature

in the room or chamber by reason of the shutting down of the machine or from other cause. This dripping is, as has been already mentioned,

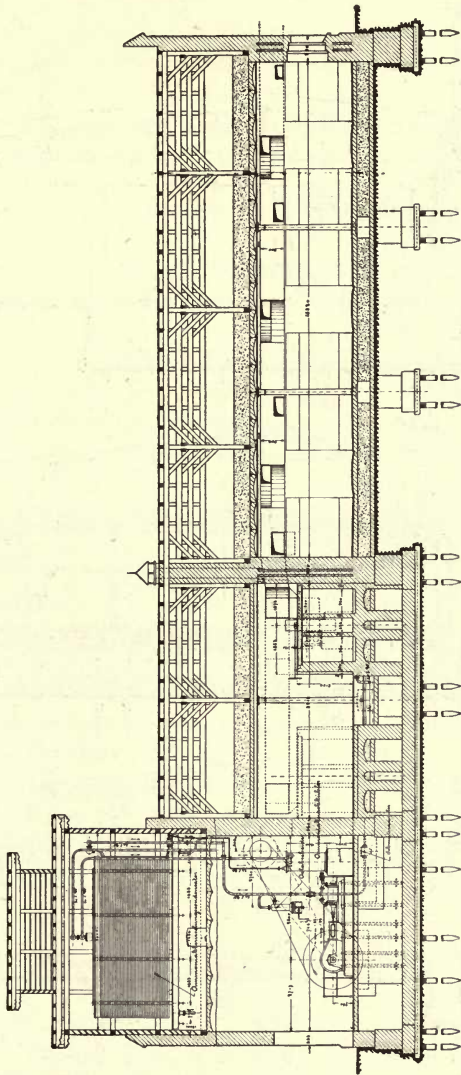
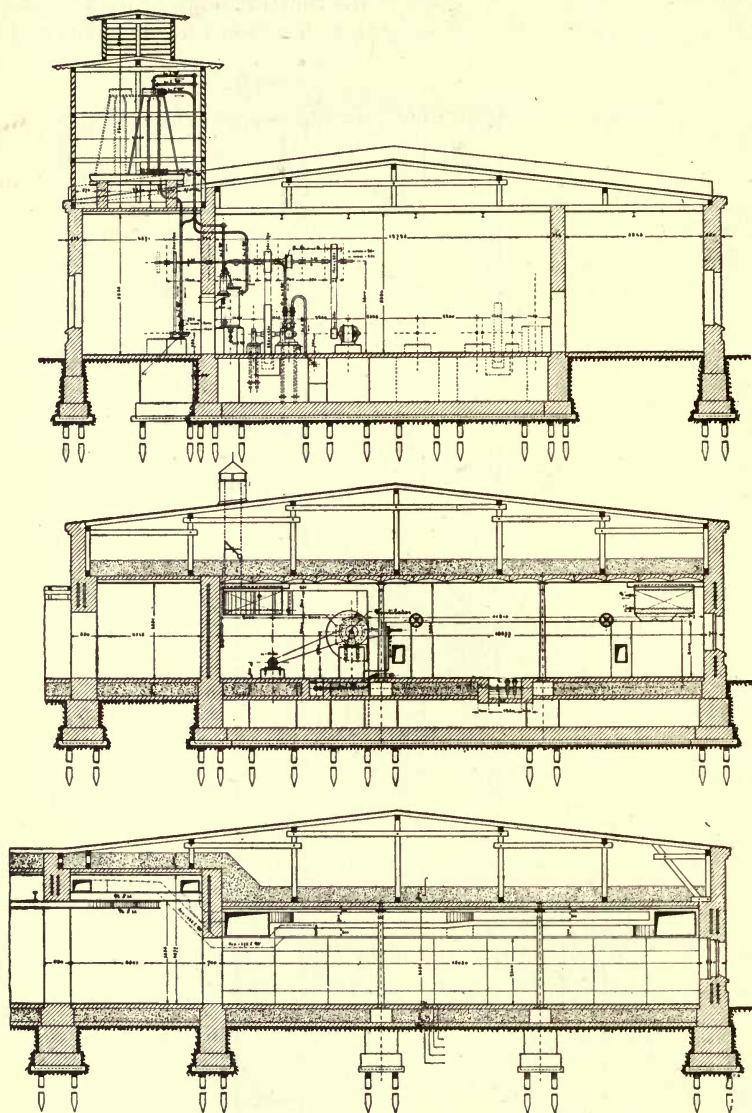

Fig. 198.—Refrigerating Installation on the Humboldt System, erected at Municipal Abattoir, Riga. Vertical Longitudinal Section.

more especially liable to occur in cases where the direct expansion system of cooling is in use.



Figs. 199, 200, and 201.—Refrigerating Installation on the Humboldt System, erected at Abattoir, Riga. Transverse Sections.

Fig. 196 is a sectional view showing the arrangement of a cold store with beef chill-rooms cooled or refrigerated by means of a Haslam patent brine air-cooling battery.

The open trough system has been already alluded to, and it is one of great simplicity, and is frequently used for the hog-cooling rooms in bacon factories. Two, three, or other suitable number of troughs are usually placed in line, vertically, one above the other, over each hook or hanging rail, and the flow of brine can be regulated by any well-known and convenient means. A large surface of cold brine is in this system advantageously exposed for absorbing heat; on the other hand, however, the open troughs have the disadvantage of taking up a very considerable amount of valuable space.

Figs. 197 to 201 show a meat cooling plant on the Humboldt system erected by them at the municipal abattoir, Riga, Russia. This plant is arranged with dry-air coolers for direct evaporation, the type of cooler employed being the Fixary improved by Humboldt in accordance with the dictation of their experience in the requirements of plants for this purpose.

The cooling pipes are arranged in the chilling, cooling, and curing rooms of bacon factories in a number of other different ways, the system having frequently to be specially adapted to the existing buildings. Sometimes the pipes are placed in the form of coils in a separate chamber or loft provided in the ceiling of the main room or chamber (as shown in Fig. 202, which shows an installation on the direct expansion system), and air, admitted through suitable apertures from the room beneath, or by means of ventilators, and cooled by passing over the surface of these coils, is allowed to circulate by gravity, or is rapidly circulated by means of fans through the room below. A somewhat similar arrangement of brine or cooling pipes is also often employed in beef and other meat rooms. An advantage of this plan is that it effectually prevents any dripping and moisture in the chill-room.

In an arrangement designed by Mr Puplett, the refrigerating pipes or coils and circulating fan are fixed in a separate compartment quite distinct from the cold rooms, but connected therewith by trunks or ducts. The cooling is effected by the constant circulation through the chill or meat rooms of a current of air that has first been cooled by passing it over the refrigerator. The air is washed and purified by being passed through a series of sprays of cold brine, and then over the refrigerator, by which it is dried and reduced to any desired temperature. The fan draws the air from the rooms through the suction trunk, and returns it by the delivery trunk after it has passed

through the refrigerating chamber and been washed, cooled, and dried; the air thus becomes colder, and is purified each time it passes over the refrigerator.

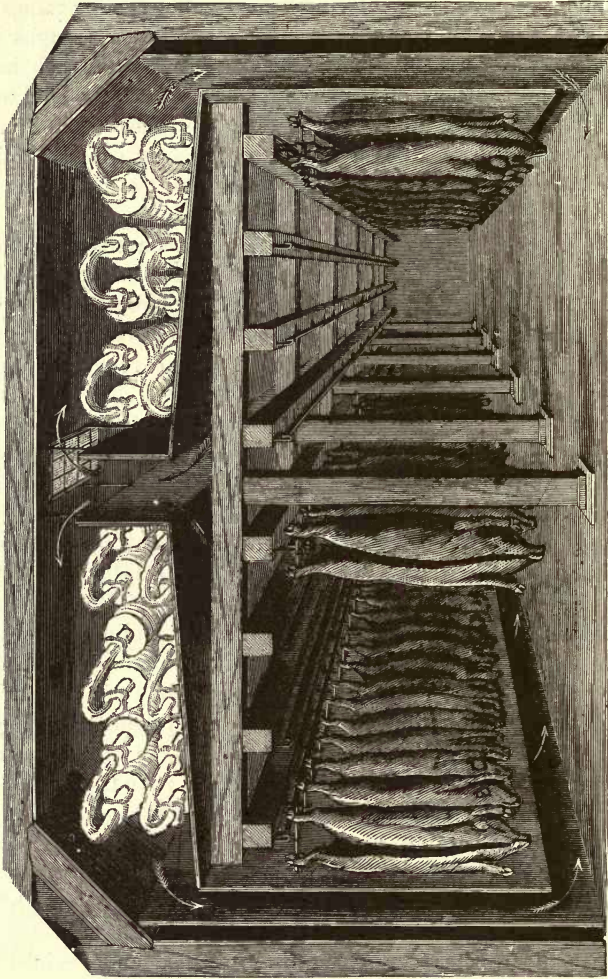

Fig. 202. — Hog Chill-room, fitted with the De La Vergne Patent Pipe System. Transverse Section.

Another method of arranging the cooling pipes is to provide coils on the sides of the chill-room, or where the chamber is of considerable dimensions, in rows placed vertically at suitable intervals lengthways of

the latter, the carcasses being suspended by hooks in the usual manner from meat or hanging rails, situated overhead, between the coils.

When the refrigerating pipes are placed directly in the cold store, suitable drip-trays (as shown in Fig. 195) can be provided if required.

Refrigerating machines are likewise very advantageously employed in bacon-curing factories or works, for enabling mildly-cured bacon to be produced in summer, by artificially reducing the temperature of the chill-rooms and curing-cellars.

A usual arrangement is shown in Fig. 203, which comprises rows

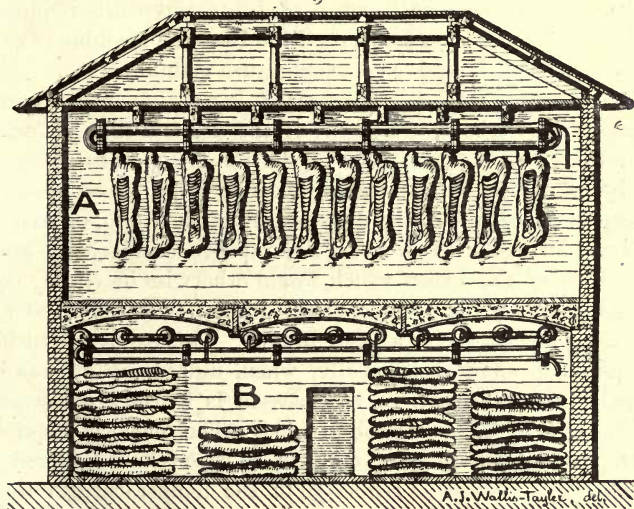

Fig. 203.—Arrangement of Cooling Pipes in Chill-room and Curing-cellar in Bacon Factory. Transverse Section.

of cast-iron flanged pipes which are fixed overhead, preferably suspended from the ceiling, over the whole area of the chill-rooms and curing-cellars, and through which system of pipes brine cooled in the usual manner is circulated so as to lower the temperature of the rooms to about 40° Fahr. By means of cocks provided on the different branch mains the speed of the flow of brine through the various circulations, and consequently the temperature of the rooms, can be regulated, and reduced, or increased at pleasure. In factories of moderate size the machine may usually be stopped at night and on Sundays, the cold stored up in the brine in the pipes being enough to

keep the temperature of the room sufficiently low; in very hot weather, and in very large establishments, however, the machine will have to be run continuously night and day.

Both the chill or cooling rooms and the curing-cellars are fitted up in practically the same manner; the work in the chill or cooling rooms where the hot meat is cooled down is much greater in proportion to their size, however, and is moreover intermittent, consequently a proportionately larger number of brine pipes are placed therein, and the brine is turned on or off as the rooms are full or empty; on the other hand the work in the curing-cellars is less and regular, and, therefore, a much smaller number of brine pipes are required, the circulation of brine being kept up all the time the machine is running, and a perfectly steady and even temperature maintained.

The reason that artificial refrigeration is now imperatively required in bacon-curing works is on account of the demand that has arisen for mild-cured bacon. Formerly the pigs, after being killed, were cooled simply by exposure to the atmospheric air, being subsequently cured in underground cellars at the temperature of the earth, or from 52° to 55° Fahr. In order to prevent the rapid decomposition, and consequent taint of the bacon which would otherwise inevitably occur at these comparatively high temperatures, the latter was charged with an excessive amount of salt as a preventative. This excessive salting was indispensable in summer especially, when, indeed, curing was almost prevented, although bacon at that season is in the greatest demand, and the highest prices are obtainable. The modern requirement, however, for more and more mild-cured bacon has rendered absolutely necessary an artificial reduction of the temperature of the chill-rooms and curing-cellars.

The first attempts in this direction were made by constructing the cellars with iron ceilings, on the tops of which were stored large quantities of ice, a system which is found to be, when properly carried out, sufficiently effective, but is very expensive, not only by reason of the first cost of the iron ceilings and the necessary supports, but also by reason of the space occupied by the ceilings and ice chambers, and furthermore on account of the large outlay entailed for the ice itself, and the labour of handling it. There is, besides this, the risk of the supply of ice running short in the hot weather, with, of course, disastrous results.

Fig. 204 is a horizontal section showing a plan of a small cold storage chamber of 1,000 cub. ft. capacity, adapted for the use of butchers, &c. The refrigeration is effected by a Haslam cold-air

machine, of 6,000 cub. ft. per hour capacity, arranged to be driven direct by means of a gas engine. A is the gas-engine cylinder, B the air-compression cylinder, and C the expansion cylinder. The air-compression cylinder B is arranged horizontally in front of, and in line

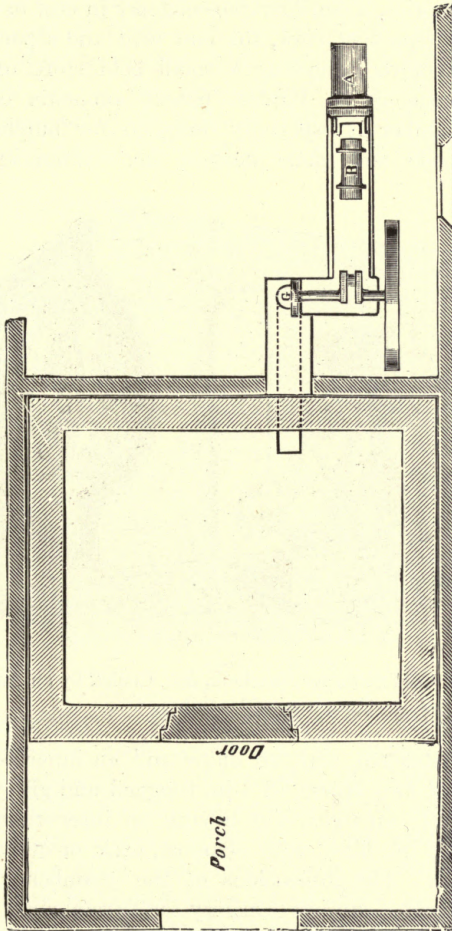

Fig. 204.—Small Cold Store for Butchers, &c., Cooled by Cold-Air Machine. Plan View.

with, the cylinder A of the gas motor, and the expansion cylinder C is placed vertically, and works a disc secured upon the opposite end of the crankshaft from the fly-wheel.

The advantages of a gas motor for driving the small cold-air

machine required for an installation of this description are obvious, and comprise: non-increase of fire insurance premium, and ability to start the machine at any time, without having to wait to get up the necessary steam pressure in a boiler, as must be done in the case of a steam-driven cold-air machine, and, moreover, except where gas is at an abnormally high price, a considerable economy in cost of running.

Fig. 205 is a perspective view, the end wall and a portion of the front wall being removed, showing a small cold store or chamber, refrigerated by means of a Puplett patent ammonia compression machine, which chamber is especially designed for butchers, bacon-curers, dairymen, fish and game dealers, &c. Chambers of this

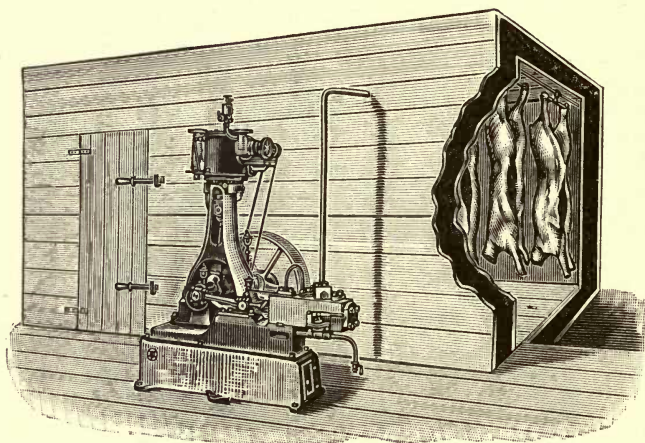

Fig. 205.—Small Cold Store for Butchers, &c., Cooled by an Ammonia Compression Machine.

description are constructed with an outer and an inner skin, each of which is composed of two layers, of 1-in. tongued and grooved boards, put together perfectly air-tight, and having an intervening space or clearance of about 8 in., filled with charcoal, cork, or other good non-conducting material. The dimensions of the chambers, as usually constructed, vary from a storage capacity for frozen meat of 6 to 50 tons or more, and their daily meat-cooling capacity to 32° Fahr. runs from 20 cwt. up to 200 cwt. or more.

In Fig. 206 is shown in vertical section a small cold storage room cooled by a Triumph ammonia compression machine, which would be suitable for an hotel or private residence. A plant of this description

can be readily operated by an ordinary man without the help of a skilled attendant, and would only require about an hour's attention during the day. The brine tank shown in the drawing keeps the refrigerator or cold storage chamber cold during the night. The compressor, which is of the double-acting horizontal type, is mounted upon a strong tank forming the condenser, and can be operated by any available source of power. A description of the Triumph compressor will be found in the chapter upon "Ammonia Compression Machines."

Fig. 207 depicts the arrangement of a one-ton ice-making and refrigerating plant in an hotel, in which, it will be seen, a number of separate cold storage rooms or chambers for different classes of pro-

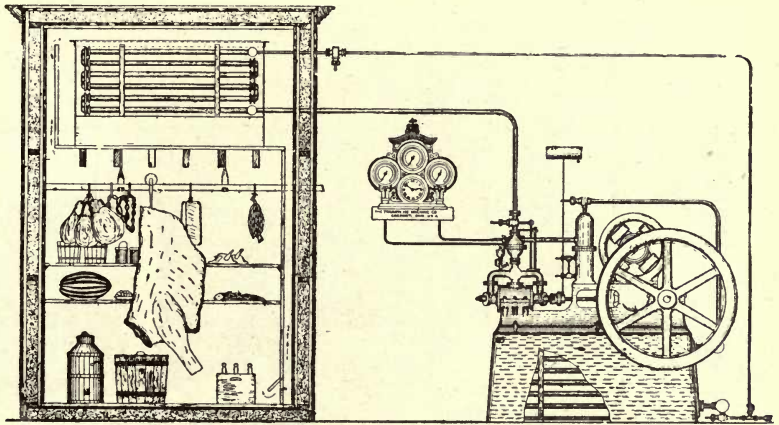

Fig. 206.—Small Cold Storage Room for Hotel or Private Residence.
Vertical Section.

visions are provided. This installation is cooled by an ammonia compression machine made by the A. H. Barber Manufacturing Co., Chicago, which type is also described in the chapter mentioned above.

It is usually advisable to provide in the kitchen of an hotel, or adjacent thereto, a short order box, which enables the too frequent opening of the main cold storage room or chamber to be avoided. This box may be cooled by a set of pipes, through which the cold brine, or, when direct expansion is employed, the refrigerating gas or medium, passes on its return to the machine after doing duty in the main cold store or chamber.

Arrangements can also be made for cooling carafes, freezing ice creams, and cooling the bar box.

The cold storage room in an hotel does not, of course, differ materially in any respect from any other, but the peculiar requirements of an hotel, and the great difficulty experienced in getting the servants to understand the necessity for judicious and careful management, are frequently very great.

To avoid the undue admission of heat to such cold storage rooms or chambers by careless persons leaving the doors open, and to render it impossible for anyone using the cold storage room to do this under any circumstances, the author has devised the door shown in horizontal section in Fig. 208, and in vertical section in Fig. 209. This door is, it will be seen, of a crescent or semi-cylindrical form, in horizontal sec-

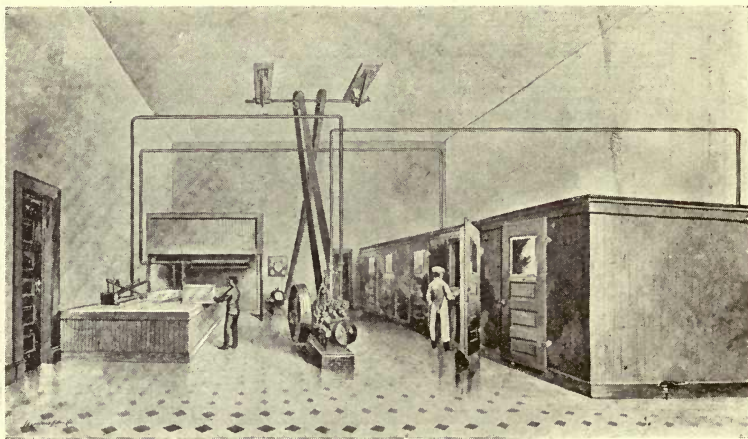
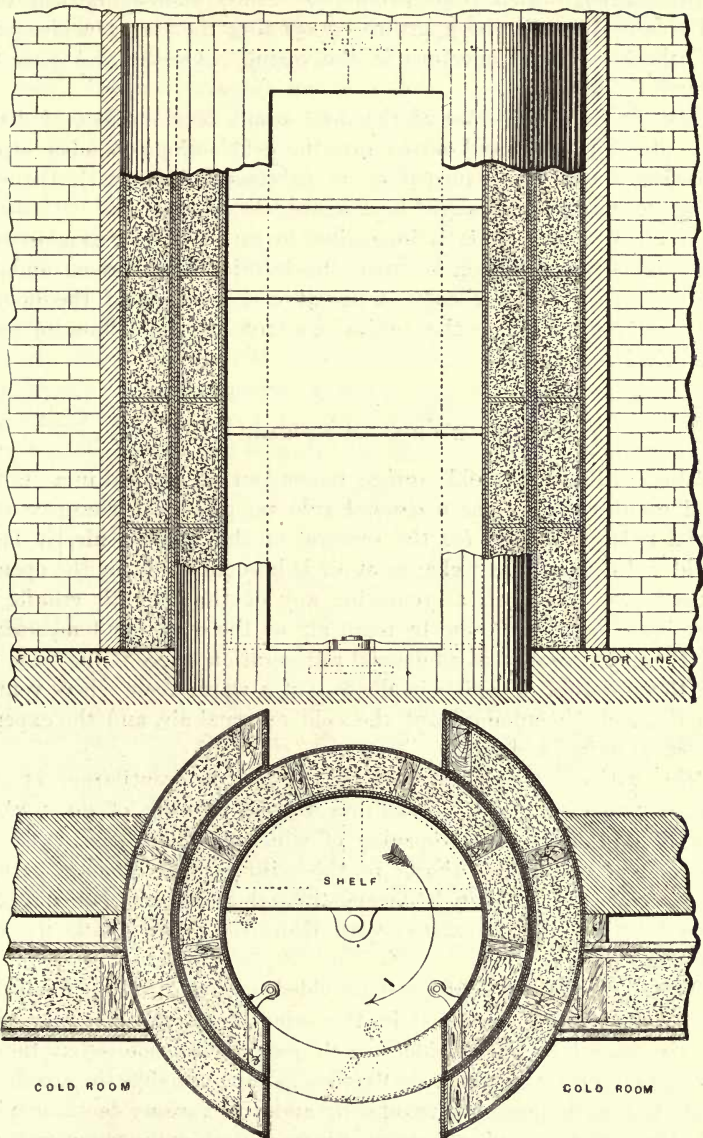

Fig. 207.—Cold Storage Rooms and Ice-Making Plant in Hotel.
Perspective View.

tion, and is mounted upon a central axis, so as to be free to turn or rotate easily thereon in a suitable casing having two apertures, the one opening into the cold storage chamber and the other to the exterior, and between the inner surface of which casing and the outer surface of the door an air-tight joint is made by means of strips of india-rubber, felt, or the like, or by spring-actuated rubber or felt-faced strips, &c.

To use this door the aperture or opening admitting to the interior of the same is brought opposite to the one or other of the apertures or openings in the casing by revolving the door upon its axis, sunk handles admitting of its ready manipulation. The person desiring



Figs. 208 and 209.—Rotating Air-Lock Door for Cold Storage Rooms in Hotels, &c. Sectional Elevation and Horizontal Section.

to pass through then steps inside the hollow semi-cylindrical door and rotates it until the aperture or opening thereof coincides with the other or second aperture in the casing, when he can pass out through the latter.

Shelves in the interior of the door admit of a number of dishes being placed thereon and moved into the cold storage chamber at one operation, or of being turned so as to communicate with the cold storage chamber, and brought back again when required.

It will be seen that it is impossible to turn this door so as to open a through communication between the interior of the room and the exterior, and the interchange of air at each opening of the door is consequently limited to the cubical contents of the hollow or semi-cylindrical door itself.

VENTILATION OF COLD STORAGE CHAMBERS.

The ventilation of cold storage rooms can be effected in a number of different ways, but as a general rule no provision whatever of a special nature is made for the removal of the vitiated air, it being considered that sufficient change of air is brought about by the opening of doors, &c. In fact, as removing any of the cold air entails the necessity of replacing same by more air at the same low temperature, and thereby necessitates additional refrigeration, there is the same dislike to ventilation as exists in the case of a warm room where ventilation demands the admission of the cold external air, and the expenditure of more fuel to heat it.

The various expedients resorted to for the ventilation of cold storage rooms comprise, in addition to the opening of doors above alluded to, the occasional opening of windows, where such exist, the provision of ventilating shafts in the ceilings, and, what is perhaps the most efficient, by artificial means, through an exhaust fan connected through suitable pipes—fitted with doors or valves—with the cold storage room.

When ventilating shafts are provided, and there are a number of cold storage rooms contained in the same store, the ducts or pipes may be placed in the corridors, each room being connected thereto through a pipe with a valve or damper so as to enable the amount of ventilation to be properly regulated, and the various ducts or pipes from the corridors having a common termination in the chimney stack, which latter provides a means for efficiently ventilating the rooms at all times.

It must be remembered that in cold storage rooms or chambers the air, being cold, sinks to the bottom, and that the tendency is therefore for it to escape through the crevices about the doors, or when the latter are opened, and thereby create a down-draught so as to render any attempt to ventilate by means of a short shaft without artificial means to produce an air current abortive.

Moisture has the property of absorbing gases and impurities, and consequently the moisture in the air of a cold storage room will take up all the emanations from the stored products. It follows, therefore, that if the air be subsequently relieved of its moisture it will be practically purified, as most of these gases can be removed.

All atmospheric air contains the germs of fungus or mould, which germs are very rapidly developed under such favourable conditions as the presence of a large amount of moisture in the air, and high temperatures, but are destroyed and removed from air in a dry and cold condition. This moisture can only be removed by ensuring a proper circulation of the air of a cold storage room relatively to the articles stored therein and the refrigerating pipes or other cooling surfaces.

CIRCULATION OF AIR IN COLD STORAGE CHAMBERS.

The circulation of air in cold storage rooms or chambers is a matter of primary importance, and one which in too many cases does not receive the attention which it deserves, with the result, more especially in the case of small rooms or chambers, that the condition of the atmosphere is anything but satisfactory, and great difficulty is experienced in keeping provisions in good condition in them.

There are two main systems of air circulation in use, viz., the gravity air circulation and the mechanical or forced air circulation.

The following particulars are extracted from three interesting and instructive articles by Mr Madison Cooper, a well-known expert upon refrigerating matters in the United States, and which articles appeared in the American journal *Ice and Refrigeration*, for May, June, and August 1901.

"METHODS OF PIPING THAT HINDER CIRCULATION.

"When mechanical refrigeration first came into the field, the arrangement of cooling surfaces and a provision for air circulation was neglected about as it was by the pioneers in natural ice refrigeration. The cooling pipes were placed almost anywhere, regardless of the laws of gravity which control air circulation. At first the ceiling of the room

was a favourite place for locating the coils of pipes for cooling the room. The ceiling was utilised because thus the pipes were out of the way in piling up goods, and also on the theory that 'cold would naturally drop.' Cold, or, more accurately speaking, cold air, will naturally drop, but placing the pipes on the ceiling of a room will not assist the circulation; it will, in fact, produce practically no circulation at all if the whole ceiling of the room is covered with pipes uniformly. Ceiling pipes have generally been abandoned for the more rational method of placing the pipes on the side walls of the room.

"Fig. 210 shows ceiling piping, and should make plain why no circulation is created when the pipes cover nearly the whole top of

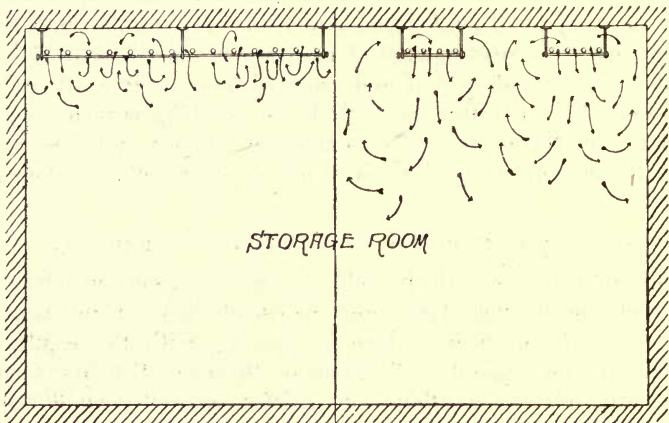

Fig. 210.—Diagram showing Gravity Air Circulation in Cold Storage Room Chamber, with Ceiling Piping.

the room. As is well known, cold air is heavier than warm air and, if free to move, the cold air will seek a lower level than the warm air. This movement of the cold air downward and the warm air upward is what is known as gravity air circulation. A slight difference in the temperature will cause a circulation of air if the warm and cold air are separated from each other and not allowed to mix, which would cause counter-currents and retard the circulation. In a cold storage room the air in contact with the cooling coils, as it is cooled, flows downward towards the floor by reason of its greater specific gravity. The comparatively warm air above is drawn down to the pipes, where it is in turn cooled, and the flow is continuous. If the entire ceiling is covered with pipes, what results? The air in contact with the

pipes cannot fall because it cannot be replaced by warm air from above. The result is that practically no circulation of air takes place in such a room. A slight local circulation in the vicinity of the pipes is all that results, except under unusual or accidental conditions. The goods are cooled for the most part by direct conduction and radiation; the top tier of goods would be cooled directly from the pipes and each tier under successively from its neighbour above in the same manner.

“Goods are cooled by radiation by the passage of heat from the goods directly to some colder object, without the heat being conveyed by the movement of the air, as it should be, and as it is where a good circulation is present in the room. In a room in which the goods are cooled by radiation mostly, the moisture instead of being deposited entirely on the cooling pipes, as it should be, is also likely to be

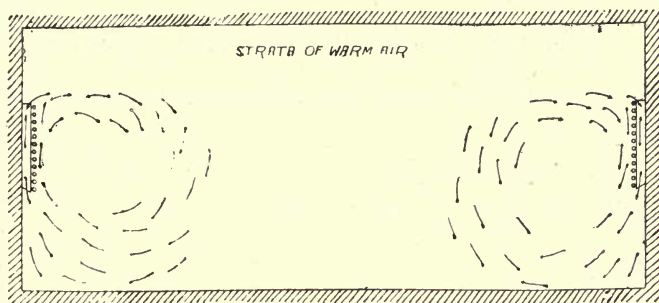

Fig. 211.—Diagram showing Gravity Air Circulation in Cold Storage Room or Chamber, with Side Wall Piping.

deposited on the walls of the room or on the goods themselves. The result of such a condition would be serious. This cooling by radiation, as compared with cooling by a circulation of air, may seem like a very finely spun theory to some, but let the sceptic watch his house for a demonstration. Is there any practical cold storage man now in the business who has not noticed an accumulation of frost or moisture on goods if they were piled too near to the exposed cooling pipes? What causes this result? Radiation, nothing else.

“The bad effects of radiation cannot be altogether overcome by placing the pipes on the sides of the room, but it is counteracted to some extent by the resulting circulation of air. Fig. 211 shows side wall piping and the resulting circulation, which is confined largely to a small space near the coils. The arrows show approximately the path of circulation. If the room is wide, no circulation at all will take place

near the centre. In some cases pipes have been carelessly placed two or three feet down from the ceiling. This results in the air of the room becoming stratified—a warm layer of air in the top of the room resting on a cold layer beneath. This may be operative to such an extent as to cause a difference in temperature between floor and ceiling as great as 10° Fahr. A case has come to the writer's notice with exactly these conditions. Another bad arrangement of side wall piping was that of a room more than 50 ft. square piped completely around on the side walls from floor to ceiling, with the exception of the doors. No circulation could penetrate to the centre of such a room, and conditions were very poor in consequence.

“MEANS FOR IMPROVING AIR CIRCULATION.

“The placing of a screen or apron in front of the side wall piping, as illustrated in Fig. 212, marks the first scientific step toward a better-

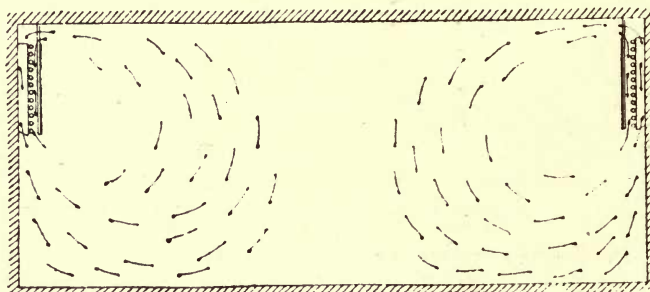

Fig. 212.—Diagram showing Gravity Air Circulation in Cold Storage Room or Chamber, with Screened Wall Piping.

ment of air circulation in a room with direct piping. It prevents the action of radiation, and assists the volume, velocity and area of circulation, but does not well take care of the centre of the room, although the increased velocity forces the air to cover a greater area and flow to a greater distance from the coils. The screen or apron should be of wood or any moderately good non-conductor. By separating the warm from the cold currents of air, the velocity is increased on the same principle that a fire burning in a flue creates a greater draught than when burning in the open air. Radiation is prevented in the same way that a fire screen protects one from a too hot fire in a grate, only the radiation, as already explained, is in a reverse direction.

“Shown in Fig. 213 is the same arrangement of screen or apron as

in Fig. 212, but added thereto is a false ceiling extending out towards the centre of the room. This addition to the perpendicular apron causes the air, after circulating over the coils, to spread out more towards the centre of the room and cover the cross-sectional area much

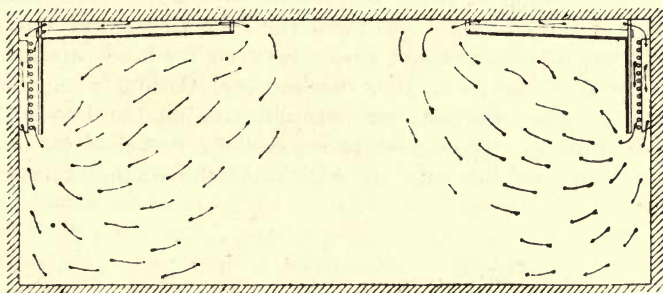

Fig. 213.—Diagram showing Gravity Air Circulation in Cold Storage Room or Chamber, with Screened Side Wall Piping and Ceiling Extensions.

more uniformly. While it decreases the velocity proportionately, it is considered a superior arrangement to the perpendicular apron alone, placed in front of the coil. The false ceiling should have a slant of about 1 ft. in 10, and the opening on the outer edge near the

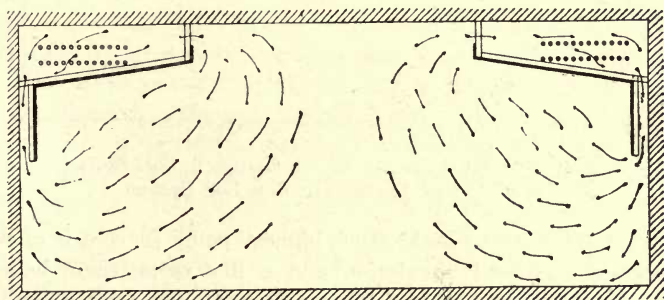

Fig. 214.—Diagram showing Gravity Air Circulation in Cold Storage Room or Chamber, with Gay's arrangement of Piping.

centre of room need not be over 3 or 4 in. in depth in most cases. Without the false ceiling some space must be left for a circulation of air at the top of the room; with it, the goods may be piled close up to the false ceiling, so no space of consequence is wasted in using it.

“The arrangement shown in Fig. 214 was first originated by Mr

C. M. Gay, as was described in the August 1897 issue of *Ice and Refrigeration*. Barring the space occupied, it is by far the best arrangement of room piping now in use. The following is quoted from Mr Gay's description: 'Upper pipes of box coils should be about 10 in. below ceiling of room, to prevent sweating. When brine or ammonia is turned into these pipes the cold air around the pipes seeks an outlet downward, and passes between the false partition and the side wall of the room, thus displacing or pushing along the air in centre of room, the cold air naturally seeking the lowest point, and the warm air the highest point, each by reason of its relative gravity. Thus, as the cold air falls from the cooling surfaces, it

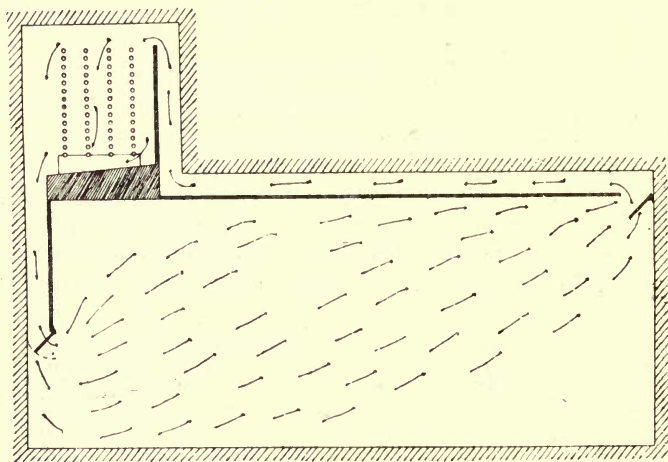

Fig. 215.—Diagram showing Gravity Air Circulation in Cold Storage Room or Chamber, with the St Clair Pipe Loft System.

is replaced by the warm air from highest point in centre of room. This secures a natural circulation and a dry room, there being no counter-currents nor tendency to precipitate moisture on walls or ceiling.' Mr Gay's remarks regarding his system apply with still greater force to the St Clair system, and to a greater or lesser extent to any system which provides for a removal of the cooling pipes from the room.

"The St Clair system, illustrated in Fig. 215, is sometimes called the pipe loft system, because the cooling pipes are placed above the storage room in a pipe loft or coil room. This is a favourite arrangement where an overhead ice cold storage house is equipped with the

mechanical system. In this case the pipes are placed in a portion of the old ice-room, and perhaps the old air ducts used for air circulation. If the storage house consists of several floors of storage, the pipe loft may be placed at the top and the rooms below all cooled from one pipe loft, but a much better method is to have an independent coil room for each room, and circulate the air through separate air ducts. This prevents contamination from foreign odours when different products are stored in different rooms.

“The circulation is more vigorous and effective with the St Clair system than with any pipe-in-the-room system, depending on the law that the higher the column of air the stronger the draught, in the same manner that a tall chimney gives a stronger draught than a short one. The effect of this is to produce a good circulation of air with a comparatively small variation of temperature. The St Clair system is also better because by suitable trap-doors on the air ducts the pipes may be shut off from the room, when the temperature is such outside as not to require the circulating of the refrigerant. The necessity of keeping the air of a storage room from contact with the frosted pipes when the refrigerant is shut off will be considered in connection with the forced or fan circulation system, to be described further on.

“MECHANICAL OR FORCED AIR CIRCULATION.

“The simplest, and probably the most unscientific, form of mechanical air circulation in cold storage rooms is the small electric fan. These fans are of the four or six-bladed disc type, of from 12 to 18 in. diameter, attached directly to the shaft of an $\frac{1}{8}$ or $\frac{1}{4}$ H.P. electric motor. The electric current for operating is usually obtained from the socket for an incandescent electric lamp. Electric fans are usually placed on the floor in the end of an alleyway, or in an opening in the piled goods, and are used for creating a flow of air from one extremity of the room toward the other. If the circulation is strong enough, these fans tend to create a uniform temperature in the room; but, as the air from the fan will follow a path of least resistance, the circulation resulting from their use is largely confined to the alleyways and openings in the piles of stored goods—it does not penetrate through and behind the goods where it would be most useful.

“The use of this type of fan in cold storage rooms is of doubtful utility, and is liable at times to lead to a positive harm by causing a condensation of moisture on the goods in storage, as a result of the warm upper stratum of air coming in contact with the cold goods in

the bottom of the room. In some cases electric fans have been used to propel the air from the cooling pipes, for which purpose they are placed in an opening in a screen or mantle covering the pipes, forcing the cooled air outwardly into the room. This is a first step toward scientific forced circulation, and is useful as far as it goes. In many cases the electric fan is useful only as a 'talking point,' as it is likely to impress a person who is not familiar with cold storage work, with the cooling power of the refrigerating apparatus, to stand for a few seconds in the breeze created by one of these high-speed fans. Their use has been adopted to an extent not at all warranted by the results to be obtained, and they will no doubt be gradually discontinued as the fallacy of the idea becomes apparent.

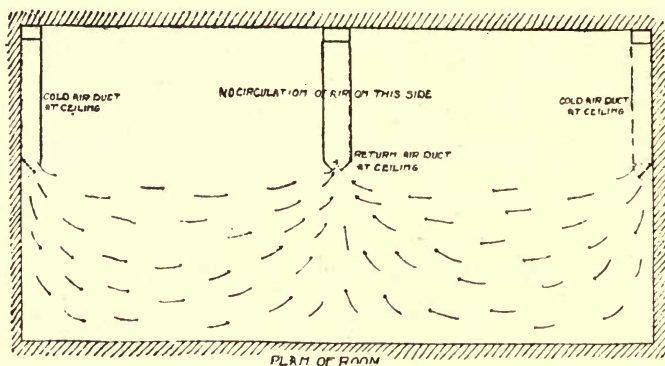

Fig. 216.—Diagram showing Mechanical or Forced Air Circulation, with Air forced into the Room at each end, and drawn out at centre.

“Those who use electric fans as above described, by so doing admit the superiority of forced circulation over the gravity system, and also admit that their rooms are in bad condition, and that some mechanical means of agitating or circulating the air is necessary. Instead of such a poor makeshift, it seems that they will eventually be forced to instal a scientific system of forced circulation.

“A system which has been installed in several large houses in the United States, and to some extent elsewhere, consists in placing the refrigerating pipes outside the storage room, and using a fan to propel the air to and from the room. Fig. 216 shows a floor plan of a room so equipped. The air is forced into the room at each end, and the return air to coil-room drawn out in the centre as shown. The cold-

air inlet at ends of room are in some cases placed at the floor and in others at the ceiling of the room, but further than this no distribution of air is attempted other than that resulting from the location of the inlet and outlet. Sometimes the ducts are arranged to force the air into the room at the centre, and the return air to coil-room is taken out at the ends, or the cold air is allowed to flow from several openings in a duct running across the centre of the room, but no real distribution results from this method.

“Employing the forced circulation system in this way is very much like the indirect systems of steam-heating as at first installed. It is noticeable now that the best steam-heating work provides a

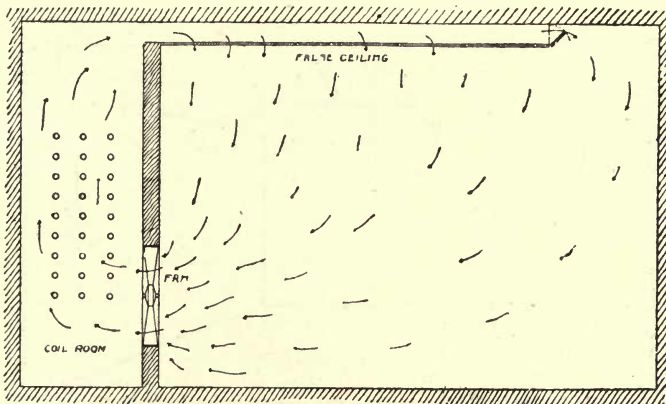

Fig. 217.—Diagram showing Mechanical or Forced Air Circulation, with False Ceiling for distributing Cold Air from the Coil-room.

thorough distribution of the heated air throughout the apartments through a great many small openings rather than forcing a large volume of air into the room at one or two places. It needs no argument or demonstration to show that a room heated or cooled by air forced in at one or two openings must have varying degrees of temperature, humidity and circulation depending on the remoteness or proximity to the direct flow of air from inlet to outlet, for the reason that the air from inlet always seeks the most direct path to the outlet and moves through the area of least resistance, usually through the central alley of room. This is a positive fact and not a theory. The writer recently visited a large room of the kind above described, and despite the manager's statement that he had tested in every known way and

found conditions absolutely uniform, the writer for himself saw a temperature variation of two degrees, and this between two thermometers hung in the centre alley of room at the same height from floor, and without any extraordinary conditions to cause such a variation. The real difference in temperature in this room between the coldest and warmest point could not have been less than five or six degrees.

"The longitudinal section of a room shown in Fig. 217 illustrates a system of forced air circulation which has been installed to a moderate extent, but has not become as well established as the one first described. A false ceiling is provided for distributing the cold air from cooling coils at the top of the room, but, as with the system just

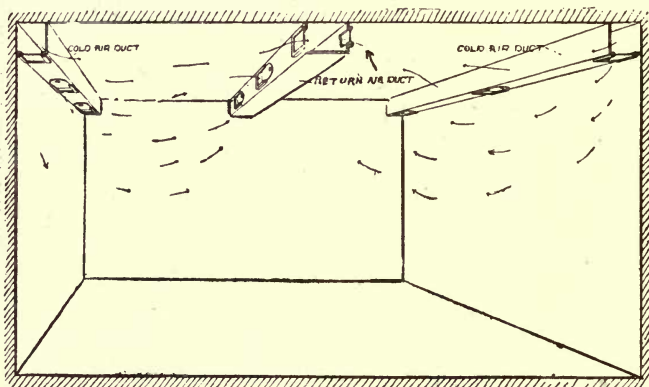

Fig. 218.—Diagram showing Mechanical or Forced Air Circulation, with Air admitted at sides of Ceiling, and drawn out at centre thereof.

described, no collecting ducts are provided for the purpose of uniformly removing the air from the room. The air from coil-room comes into the room through narrow slit-like openings in the false ceiling, and is returned to the cooling coils through and by the disc fan located in the partition between coil-room and storage-room. It would seem that this is working counter to the natural laws of gravitation, although it may be looked at in another light also.

"It is often remarked that 'cold will naturally drop,' but this should not confuse us when studying the means for promoting circulation. If the cold air is admitted to the room at the top, it will of course fall to the floor if allowed to do so; but why admit the cold air at the top of the room if it is wanted at the floor? In a room

fitted with direct piping the cold air does not drop through the goods in storage, but down over the cooling coils, and rises through the goods in storage as it is warmed. It would seem, then, that any method of distributing the cold air at the top of the room is wrong in principle, especially as no means of uniformly drawing off the air at the bottom of the room is provided. When warm goods are placed in a room equipped in this way, the moisture given off as the goods are cooled must be very liable to collect on the cold false ceiling. To provide uniform temperatures and humidity with this system it is necessary to provide a very strong blast of air, which is to be avoided, as goods directly in front of the fan may be exposed to too great a drying influence.

“The arrangement of collecting and distributing air ducts shown in the cross section of room, Fig. 218, has been installed in a number of houses in America, and, like some of the others, depends on the ‘cold will naturally drop’ theory for its operation. The arrows show the natural tendency of the air circulation from the cold air ducts on the sides of the room to the warm air collecting duct in the centre. In some cases the cold air is distributed in the centre and collected at the sides of the room, and where the room is narrow only two ducts are used, as in Fig. 219, a cold air distributing

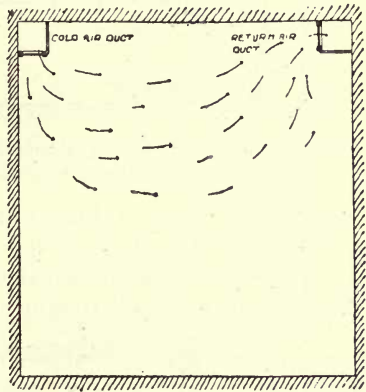

Fig. 219.—Diagram showing Mechanical or Forced Air Circulation, with Air admitted at one side of Ceiling, and drawn out at the other side.

duct on one side of the room and a warm air collecting duct on the opposite side. In every case the ducts are placed at the ceiling, on the theory that the air from cold air duct will drop and distribute itself along the floor before being drawn back to the coil-room through the return duct. The openings provided in the air ducts of this system are usually square openings, fitted with sliding gates to regulate the flow of air into the room and its return to cooler. These gates are placed 5 or 6 ft. apart, consequently a good distribution of air is not provided, and goods exposed to the rapid flow of air directly in front of the openings will get a much greater volume of circulation than is to be found in any other part of the room.

When a room of this kind is filled with goods, preventing the air from falling directly from the cold air duct to the floor, no circulation of consequence will be obtained near the floor, for the reason that air will

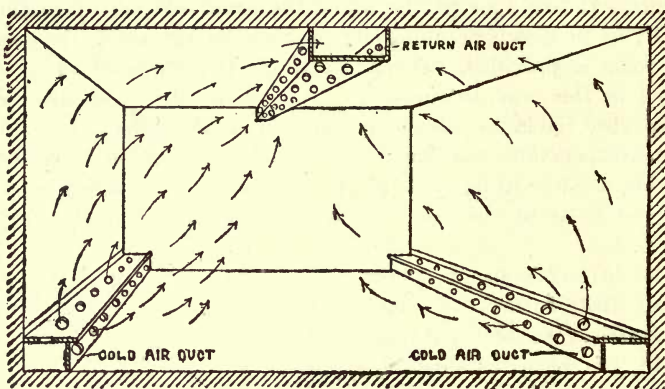

Fig. 220.—Diagram showing Mechanical or Forced Air Circulation, with Air admitted at each side of Floor, and drawn out at centre of Ceiling.

travel through path of least resistance, almost directly from feeder duct to return duct, about as shown by the arrows.

"A method somewhat similar to the one just described is that in which the cold air distributing ducts are placed at the floor and

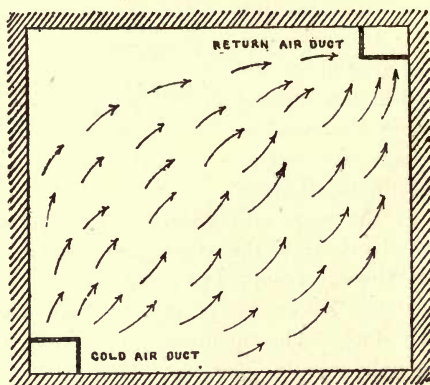

Fig. 221.—Diagram showing Mechanical or Forced Air Circulation, with Air admitted at one side of Floor, and drawn out at other side of Ceiling.

the warm air return duct is placed at the ceiling, as represented by the cross sections of rooms, Figs. 220 and 221. In narrow rooms

one distributing duct is used as shown in Fig. 221. In wider rooms two distributing ducts on opposite sides of the room at the floor are used, and one collecting duct at ceiling in centre of room. This arrangement has the merit of operating according to the laws of gravity, but still lacks the thorough distribution of cold air and collection of warm air, as shown in the system described further on. It is, however, considerable of an improvement on any of the preceding methods, and the writer has demonstrated in actual service that it will produce fairly uniform circulation and temperatures with a comparatively gentle flow of air. This system is to be recommended for goods which do not give off much moisture. It is preferable to use

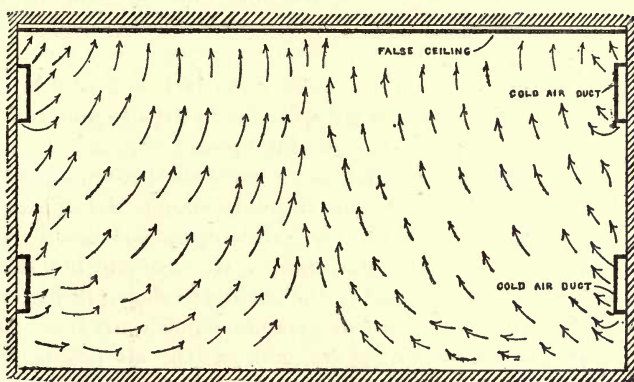

Fig. 222.—Diagram showing Mechanical or Forced Air Circulation, with Air admitted at two Ducts on each side of Wall, and drawn out through Perforated False Ceiling.

numerous small holes rather than a few large openings in the supply and return ducts.

“The system shown in the cross section of room, Fig. 222, was developed by the writer (Mr Cooper) after some experiments, and has since been improved by two successive steps. It was the old trouble of sluggish circulation, especially during the fall and winter, which impelled the writer to experiment for its betterment. As an improvement over the small electric fan already mentioned, an exhaust fan was fitted up to take air from the cooling apparatus and deliver it to the rear end of the room through a perforated duct. The air was allowed to find its way back to the coils as best it could.

“This method was applied to a long narrow room, and certainly

was a decided improvement over the sluggish natural circulation which it superseded. Following this, the perforated false ceiling was applied, with distributing cold air ducts on the walls, as shown in Fig. 222. The cold air from coil-room was forced into small holes in the top, bottom, and sides of the cold air ducts. The warm air from the room flowed upwards through the small perforations in the false ceiling and through the space between the ceiling of the room and false ceiling, and thence to the coil-room, where the air was cooled, and caused to repeat the same circuit continuously. The first apparatus was clumsy, and the proportions of the various parts not correct, but the efficiency of a forced circulation of air, and a thorough distribution and collection of the incoming and outgoing air of a cold storage room so plainly proven, that a further development of the idea was undertaken.

"It was demonstrated by above-described experiments that a comparatively small amount of air well distributed and uniformly drawn off at the top of the room after flowing upward through the goods in storage, would produce very uniform conditions throughout the entire area of the room. Following up this information the apparatus was reduced to a more practical form by substituting one broad duct near the floor, as in Fig. 223, for distributing the cold air, in place of the two distributing ducts as used in the apparatus shown in Fig. 222.

"The top duct of the two did not accomplish any result of consequence, and was considered objectionable, as the air passing from this duct to the false ceiling did not percolate through the goods to any considerable extent, and resulted practically in a loss of the work done by the air flowing from the top duct. Two ducts also made the apparatus more complicated. Using the broad single distributing duct near the floor in combination with the false ceiling resulted in very penetrating and uniform circulation of air, and in practical service it has been found to produce superior results.

"No practical objections have been urged against it. As shown by the arrows, the air is caused to cover very uniformly the entire cross-sectional area of the room. This was accomplished by perforating the distributing ducts with small holes, and so proportioning them that a larger part of the flow of air is from the bottom of the ducts. The ducts are also perforated to some extent on sides and top. By piling the goods a few inches off the floor the air from bottom of ducts flows under the goods and out to centre of room. This action is also assisted by having the greater number of the perforations in false ceiling in the middle third or quarter of the room, so as to draw the

air out from sides of room. As indicated by the arrows, the air moves up from the distributing duct, is drawn into space above false ceiling, and returned to coil-room to be cooled.

“The system described in the foregoing paragraph is nearly theoretically perfect so far as a uniform circulation of air is concerned, and a more thorough method than any of its predecessors, but it still remained to design the perforated false floor and false ceiling combination, Fig. 224, to produce a system which cannot be improved upon theoretically. Not only is the system theoretically perfect, but its practical application is so simple as to be unobjectionable. As shown

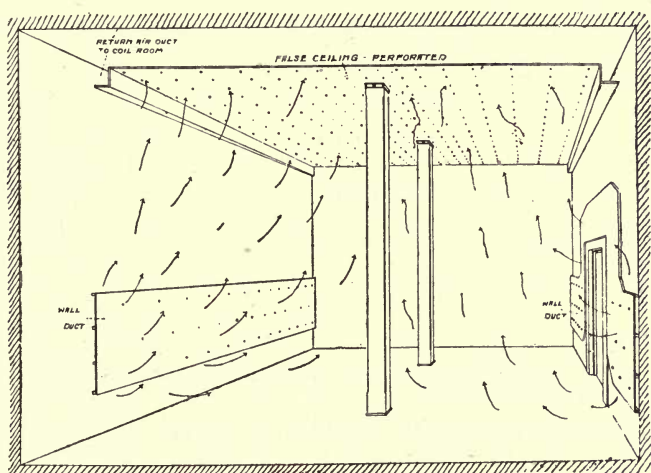

Fig. 223.—Diagram showing Mechanical or Forced Air Circulation, with Air admitted at one broad Duct on each Side Wall, and drawn out through Perforated Ceiling.

clearly by the sketch, the flow of air is directly upward from floor to ceiling, consequently all goods piled in such a room are exposed to exactly the same conditions as to circulation, temperature, humidity, and purity of the air. In a room equipped with this system, with the parts correctly proportioned, it is entirely safe to pile goods closely, only allowing a fraction of an inch between the packages and at sides of room and placing thin strips beneath the goods to allow air to flow from perforations in false floor.

“Where, in rooms fitted with direct piping and some of the fan systems as well, a large space must be left at floor and ceiling for a

circulation of air, with this system goods may be piled close up to ceiling leaving only half an inch for the air to flow into perforations in false ceilings. As the space occupied in height by false floor and its space underneath is only $1\frac{3}{4}$ in. and that occupied by false ceiling only $1\frac{1}{4}$ in., it will be apparent that much space will be saved by using this system. After a room is filled with goods and cooled down to the correct carrying temperature, no difference in temperature can be noticed in different parts of the room. No blast of air can be felt in any place, a gentle flow from perforations only is noticeable, therefore no particular place has more circulation than another to

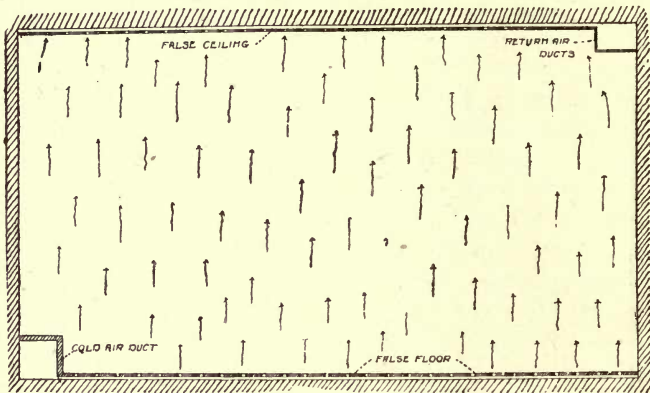

Fig. 224.—Diagram showing Mechanical or Forced Air Circulation, with Air admitted through Perforated Floor, and drawn out through Perforated Ceiling.

cause a drying out of the goods. The advantages of this system over any of the others may be summed up as follows:—

“1. A more equal distribution of air, especially when the room is filled with goods. Goods in centre of room are exposed to the same temperature, circulation, &c., as those at sides.

“2. Saving in space, as it allows the room to be filled full of goods without leaving large spaces at top and bottom for a circulation of air.

“3. Where the air is so perfectly distributed and collected it is not necessary to circulate such a large volume, saving in power and lessening the liability of evaporation of goods.”

INSULATION.

Besides being non-conductive, a good insulating material should be non-odorous, non-hygroscopic, or deliquescent, not liable to silt, both vermin and fire proof, and inexpensive.

The efficient insulation of a freezing-room or of a cold store, or refrigerating chamber, is a matter of very great importance from an economical point of view. This will be apparent when it is remembered that when once the contents of the cold store or chamber are reduced to the requisite temperature, the entire work required of the refrigerating machine will be only that which is necessary to neutralise the heat that passes through the walls, floor, and ceiling from the exterior. Consequently, the more perfect the insulation, the less the machine will be called upon to work, and naturally in a corresponding ratio also will be the saving effected in fuel, wear and tear of the working parts, and in attendance.

The means adopted for insulation consist in lining the room, or, in the case of a marine installation, the hold of the vessel, with some material forming a very bad conductor of heat. The exact method of carrying this out, as also the nature of the non-conducting material employed, must necessarily be considerably varied according to the circumstances of each particular case.

Mr Lightfoot recommends as a fairly good protection an outer and an inner layer of tongued and grooved boards, 1 in. or $1\frac{1}{2}$ in. thick, with a 9-in. space or clearance between them filled with charcoal, or in some cases preferably with silicate cotton or slag-wool.

In France and Germany cork is used with marked success as a non-conductor, and it is evidently a substance exceedingly suitable for the purpose in question, being a material very impervious to heat, and capable of withstanding moisture. Either ordinary cork cut into thin slices, or refuse or waste cork, from other industries, thoroughly ground up or disintegrated into a coarse powder, is employed, the former being the best but the most expensive. In New Zealand and Australia pumice stone is much used.

Various other substances such as asbestos, cotton-wool, sheep's wool, pine-wood, loam, gas works breeze, coal ashes, sawdust, hair felt, lampblack, mica, paper, fine cinders, pitch, &c., are likewise employed for purposes of insulation. A number of different compositions have also been tested and used as heat insulators, amongst which may be mentioned the following:—Composition of fossil meal, composed of 60 per cent. of washed white German kieselguhr, and 40 per cent. of

binding material; composition of kieselguhr from German mines, with 10 per cent. of binding matter, such as fibre, and mucilaginous extract of vegetable; cement composed of blue clay mixed with flax; jute and woollen waste, or cow's hair, in equal proportions; fibrous composition of fine blue clay mixed with flax, hemp, rope, jute, cow-hair, and woollen waste; and a papier mâché composition composed of paper-pulp mixed with clay and carbon, together with hair and fragments of hemp-rope.

In choosing a substance other considerations besides its good insulating powers must be taken into consideration, such, for instance, as its capacity for withstanding moisture. This latter quality is of the utmost importance, inasmuch as at very low temperatures moisture from the air is very readily absorbed by many substances, and fermentation, rotting, and decay will result therefrom. It is for this reason that cork forms so desirable a material for insulating purposes, although surpassed in non-conductibility by some others. For a like reason pitch, or some form of enamel composed of bitumen and other ingredients, is found to be very valuable. Lampblack is claimed to be a very good material for insulating purposes in railway and other portable refrigerating chambers by reason of its lightness and elasticity, and more particularly on account of its non-liability to pack from jolting, and complete imperviousness to moisture. This material is the one employed by Henry Carr Godell, in his patent (1884) movable refrigerating chamber. When it is desirable to increase the elasticity and reduce the cost, he sometimes uses a mixture of either short fibre or scales of mica.

Whatever the filling material that may be employed for insulating purposes, however, it should always be borne in mind that the more air that is enclosed with it between the walls or skins the better, for it is a well-known fact that the best non-conductor of heat is dry air, the units of heat transmitted per square foot per hour, through a layer of confined air of 1 in. in thickness, being about .29.

When charcoal is employed it should be well dried, and packed as nearly as possible to a consistency of 11 lbs. per cubic foot. Silicate cotton or slag-wool is usually packed to a consistency of about 12 lbs. per cubic foot, one ton equalling about 187 cub. ft. Some engineers prefer, however, to use 13 lbs. per cubic foot.

The following table, from experiments by Pecelet, gives the amount of heat in units transmitted per square foot per hour, through various substances, in plates or layers of 1 in. in thickness, many of which are suitable for insulating cold-air or refrigerating chambers. The experi-

ments were made by heating one side of the plates or layers by means of hot water, and cooling the other side by cold water, the difference between the temperature of the two faces being 1° Fahr.

| Materials. | Units of Heat transmitted. | Materials. | Units of Heat transmitted. |
|---|----------------------------|---------------------------------|----------------------------|
| Gold - - - - | 625 | Gutta-percha - - - | 1·37 |
| Platinum - - - - | 600 | India-rubber - - - | 1·36 |
| Silver - - - - | 595 | Brickdust, sifted - - - | 1·33 |
| Copper - - - - | 520 | Coke, in powder - - - | 1·29 |
| Iron - - - - | 230 | Iron filings - - - | 1·26 |
| Zinc - - - - | 225 | Cork - - - - | 1·15 |
| Tin - - - - | 178 | Chalk, in powder - - - | ·86 |
| Lead - - - - | 113 | Charcoal (wood) in powder - - - | ·63 |
| Marble - - - - | 24 | Straw, chopped - - - | ·56 |
| Stone - - - - | 14 | Coal powder, sifted - - - | ·54 |
| Glass - - - - | 6·6 | Wood ashes - - - | ·53 |
| Terra-cotta - - - - | 4·8 | Mahogany dust - - - | ·52 |
| Brickwork - - - - | 4·8 | Canvas, hempen, new - - - | ·41 |
| Plaster - - - - | 3·8 | Calico, new - - - | ·40 |
| Sand - - - - | 2·17 | Writing paper, white - - - | ·34 |
| Oak, against the grain or fibre - - - - | 1·7 | Cotton and sheep's wool - - - | ·32 |
| Walnut, with the grain or fibre - - - - | 1·4 | Eiderdown - - - | ·31 |
| Fir, with the grain or fibre - - - - | 1·37 | Blotting paper, grey - - - | ·26 |

The quantity of heat in units, transmitted through 1 sq. ft. of plate per hour, may be found thus: subtract the temperature of the cooler side from that of the hotter side of the plate, then multiply the result by the number in the preceding table corresponding to the material used, and divide the product by the thickness of plate. Thus an iron plate 2 in. thick, having a temperature of 60° on one side and 80° on the other, will transmit $80 - 60 = \frac{20 \times 230}{2} = 2,300$ units of heat per square foot per hour.*

A series of five experiments † on radiation at low temperatures were conducted by Raoul Pictet on the rate of heating of a body cooled to -170° Cent. (-338° Fahr.), the surrounding atmosphere being at a temperature of +11° Cent. (+51·8° Fahr.).

The refrigerators employed were cooled by a mixture of sulphur di-

* Hutton, "Works Managers' Handbook," Crosby Lockwood & Son.

† "Comptes Rendus de l'Académie des Sciences," Paris, vol. cxix., p. 1202. 1894.

oxide and carbon dioxide (Pictet's special liquid), or by liquid nitrous oxide, their thermal capacity being considered in every case. In the first experiment the surface of the refrigerator was uncovered; in the second it was encased in a sufficient covering of cotton waste to prevent the formation of hoar frost on the metal; whilst in the third, fourth, and fifth series protecting layers of 10, 25, and 50 centimetres in thickness were employed.

The results showed that at extremely cold temperatures between -170° Cent. (-338° Fahr.) and -100° Cent. (-212° Fahr.) a thick layer of cotton afforded but a slight protection. It was only between the temperatures of -20° Cent. (-68° Fahr.) and $+10^{\circ}$ Cent. ($+50^{\circ}$ Fahr.) that the effect of the protecting layers became proportional to their thickness.

In the opinion of Mr Pictet, bad conductors of heat are capable of absorbing, with considerable efficiency, the radiations from bodies at temperatures between -60° Cent. (-140° Fahr.) and $+11^{\circ}$ Cent. ($+51.8^{\circ}$ Fahr.), but are ineffective as regards calorific vibrations at temperatures below -60° Cent. (-140° Fahr.). With other non-conducting substances, such as silk, wool, sawdust, cork, charcoal powder, and peat, the results were identical, and, as a rule, bad conductors appeared to be freely permeable to heat at low temperatures between -100° Cent. (-212° Fahr.) and -170° Cent. (338° Fahr.).

The table on the next page gives the results of tests* undertaken by Professor Andrew Jamieson, M.Inst.C.E., for the purpose of determining the relative and absolute thermal conductivities of substances used as lagging for steam boilers, for parts of steam engines, and for refrigerating machines. The method adopted was to observe the fall of temperature in a known weight of hot water contained in a vessel coated on all sides with a certain thickness of the material under examination, the outer surface of which was maintained at a constant temperature by the continuous flow of cold water through a water jacket.

The apparatus consisted of three cylindrical tin cases, the innermost of which was fitted with a water-tight lid having a central funnel through which the hot water was inserted. The space or clearance of 1 in. left between the first or innermost vessel, and the second vessel, contained the non-conducting material under test; and the space between the second and third vessel formed the water jacket. Thermometers were placed in the hot-water chamber and water jacket, and

* *Minutes of Proceedings, Institution of Civil Engineers*, vol. cxxi., Session 1894-95, pp. 291, 292, 293, 294, 295.

an arrangement for stirring the water in said hot-water chamber in the innermost vessel was likewise provided. Each specimen of non-conducting material was placed upon a separate inner case, each of the latter being covered to an uniform thickness of 1 in. in the manner in which the material would be employed in actual practice. The non-conducting composition was applied in layers, carefully dried in succession, so as to ensure the dryness necessary to the accuracy of the tests being obtained.

RESULTS OF THE TESTS.

| Name of Material. | Weight of Sample (including Tin). | | Total Fall of Temperature in 120 minutes. | Thermal Conductivity in Absolute Measure. | Conductivity as Compared with Dry Still Air. |
|--|-----------------------------------|-----|---|---|--|
| | lbs. | oz. | Deg. Cent. | | |
| Dry air - - - - - | ... | | 6.0 | 0.0000558 | 1.00 |
| Fossil meal composition - - | 7 | 2 | 21.5 | 0.0002689 | 4.82 |
| Cement with hair felt * - - | 5 | 15 | 30.0 | 0.0003613 | 6.47 |
| Silicate cotton, † or slag-wool - | ... | | 29.0 | 0.0003875 | 6.95 |
| Kieselguhr ‡ composition - - | 7 | 13 | 29.0 | 0.0004336 | 7.77 |
| Papier mâché composition § - | 7 | 6 | 35.5 | 0.0004424 | 7.93 |
| Fibrous composition (flax, hemp, cow-hair, and clay) - | 9 | 9 | 34.5 | 0.0004550 | 7.98 |
| Papier mâché composition - | 8 | 12 | 37.5 | 0.0005019 | 8.99 |

The covered tin cases were tested as follows:—10 lbs. of boiling water was poured through a funnel into the hot-water chamber. Cold water was then allowed to flow uniformly from the main water-pipe, and to circulate freely through the cold-water chamber. During no test was the temperature in this chamber observed to rise as much as 1° Cent. The outer surface was, therefore, kept at a constant tempera-

* The outside diameter of this sample was about $\frac{1}{4}$ in. smaller than the inside diameter of the middle tin case or vessel, and it had consequently a slight advantage over the other samples in having a thin layer of air between its outer surface and the latter.

† The silicate cotton was pressed together tightly, and thus its conductivity appears greater than would have been the case had it been more loosely packed.

‡ The Kieselguhr employed consisted on the average of silica 83.8, magnesia 0.7, lime 0.8, alumina 1.0, peroxide of iron 2.1, organic matter 4.5, moisture and loss 7.1. It was employed in conjunction with 10 per cent. of binding material, viz., fibre and mucilaginous extracts of several vegetable matters.

§ Papier-mâché composition, consisting of paper pulp mixed with clay and carbon, together with hair and fragments of hemp rope.

|| A lighter modification of above.

ture throughout each test. In order to prevent the temperature of the hot water from falling too quickly at first, and to bring the non-conductor and the whole apparatus to a condition of constant temperature or heat equilibrium, steam at atmospheric pressure generated in a Florence flask was first passed into the inner vessel by means of a glass tube led into it through the funnel. The steam-pipe was then removed, and a paraffined cork fitted tightly into its position. The first reading was always taken when the temperature of the hot water had just fallen to 94° Cent. (201·2° Fahr.). The water in inner chamber was stirred by a perforated piston prior to the readings of the thermometers in the two chambers, which were taken simultaneously, being noted. Successive readings of both thermometers were taken in the same way, and recorded every ten minutes.

The results of tests* made by Mr John G. Dobbie, superintending engineer at Calcutta to the British India Steam Navigation Company, to determine the conductivities of asbestos and Kieselguhr composition were as follows :—

RESULTS OF TESTS.

| | Asbestos. | Kieselguhr Com- position. |
|----------------------|-------------------------------|-------------------------------|
| | Water Condensed in Inches. | Water Condensed in Inches. |
| After 15 minutes - | 4 $\frac{1}{4}$ | 2 $\frac{1}{2}$ |
| " 30 " - | 3 $\frac{3}{8}$ | 2 $\frac{3}{8}$ |
| " 45 " - | 3 $\frac{3}{8}$ | 2 $\frac{1}{4}$ |
| " 60 " - | 3 $\frac{3}{8}$ | 2 $\frac{1}{8}$ |
| Totals in one hour - | 14 $\frac{3}{4}$ | 9 $\frac{1}{4}$ |

This experiment shows a saving of 36 per cent. in favour of Kieselguhr composition. The tests were made with two boiler-tubes—3 $\frac{1}{2}$ in. in outside diameter and 7 ft. long, closed at both ends, and covered with a thickness of 2 in. of asbestos and Kieselguhr composition respectively. The tubes were suspended side by side, and steam was admitted at the top, a gauge-glass being fitted at the bottom of each by which the amount of condensation inside the tubes could be accurately observed. Steam at a pressure of 30 lbs. per square inch was used in the tubes.

* *Minutes of Proceedings, Institution of Civil Engineers*, vol. cxxi., Session 1894-95, pp. 301, 302.

In the first trial, which lasted one hour, 12·375 in. of water were condensed in the tube covered with asbestos, and 8·375 in. in that covered with Kieselguhr composition, showing 33 per cent. less water condensed with Kieselguhr composition. In the second trial, of one hour also, the condensation was noted every fifteen minutes, and gave the results shown in the above table.

From these and other tests the author has been led to the conclusion that hard-pressed asbestos paper or cloth is a better conductor of heat than silicate cotton or slag-wool, felt, hair, wool, or some of the Kieselguhr compositions. The main reason for the superior non-conductivities of porous materials is on account of the entrapped and occluded air, hence the looser asbestos and other fibrous materials are laid on the better will they prevent radiation of heat.

In an appendix* to his paper on heat-insulators, Professor Jamieson gives some accounts of previous experiments, of which the following is a brief extract:—

“In 1881, Mr Charles E. Emery, Ph.D., wrote a paper † on ‘Experiments with Non-Conductors of Heat,’ wherein the results of his tests on fourteen different substances are given. The apparatus used consisted of a boiler, 4 ft. in diameter and 12 ft. long, constructed with three 10-in. tubes. Into these tubes were placed smaller tubes to receive steam, and around the inner tubes were placed the non-conducting substances, water being circulated through the larger shell outside of the outer tubes. The results (see table, page 336) were shown by the amount of steam condensed in the inner tubes, the water of condensation being conducted to small cylindrical vessels, each provided with a glass gauge.”

In 1884, Professor John M. Ordway, of Boston, Mass., described in a paper ‡ on “Experiments upon Non-Conducting Coverings for Steam Pipes,” tests of a great variety of substances by three methods, viz.: (1) by measuring the temperatures on the outside of the coverings; (2) by measuring the weight of steam condensed in a certain time over a certain length of covered pipe; (3) by a calorimeter.

In 1884, Mr J. J. Coleman gave § the results of a series of experi-

* *Minutes of Proceedings, Institution of Civil Engineers*, vol. cxxi., Session 1894-95, pp. 298-299.

† *Transactions, American Society of Mechanical Engineers*, vol. ii., 1881, p. 34.

‡ *Transactions, American Society of Mechanical Engineers*, vol. v., 1883-84, p. 73.

§ *Proceedings, Philosophical Society of Glasgow*, vol. xv., 1883-84, p. 90.

ments (see table) on eight substances tested by means of Lavoiser's ice-calorimeter. The object of the experiments was to find the substance which would make best covering for the "Bell-Coleman Freezing Machines."

In 1884, Mr D. K. Clark, M.Inst.C.E., reported* to the National Smoke Abatement Institution the results of tests carried out at the works of Messrs Samuel Hodge & Sons, Millwall, of seven substances as compared with a bare pipe.

In 1891, Mr W. Hepworth Collins read a paper † on "The Comparative Value of Various Substances used as Non-Conducting Coverings for Steam Boilers and Pipes," giving the results of experiments in which a mass of each material to be experimented upon, 1 in. thick, was carefully prepared and placed on a perfectly flat iron plate or tray, which was then maintained at a constant temperature of 310° Fahr. The heat transmitted through each non-conducting mass was calculated in lbs. of water heated 10° Fahr. per hour (see table).

RESULTS OF DIFFERENT EXPERIMENTS ON THE HEAT CONDUCTIVITIES
OF VARIOUS SUBSTANCES.

(Silicate cotton being taken as 100.)

| Substance. | C. E. Emery, 1881. | J. J. Coleman, 1884. | W. H. Collins, 1891. | Prof. Jamieson, 1894. |
|--|-----------------------|-------------------------|-------------------------|--------------------------|
| Fossil meal composition - - - | .. | .. | .. | 70 |
| Cement with hair-felt - - - | 83 | .. | .. | 93 |
| Silicate cotton or slag-wool - - - | 100 | 100 | 100 | 100 |
| Hair-felt or fibrous composition - - - | .. | 117 | 114 | 112 |
| Papier-mâché - - - | .. | .. | 147 | 111 |
| Kieselguhr composition - - - | .. | 136 | .. | 112 |
| Sawdust - - - | 112 | 163 | 142 | .. |
| Charcoal - - - | 132 | 140 | .. | .. |
| Cotton wool - - - | .. | 122 | .. | .. |
| Sheep's wool - - - | .. | 136 | .. | .. |
| Pine wood (across the grain) - - - | 150 | .. | .. | .. |
| Loam - - - | .. | .. | .. | .. |
| Gasworks breeze or coal ashes - - - | 240 | 230 | 299 | .. |
| Asbestos - - - | 229 | .. | 179 | .. |

* *The Engineer*, vol. lvii., 1884, p. 65.

† "Report of the British Association for the Advancement of Science," Cardiff, 1891, p. 780.

RESULTS OF TESTS TO DETERMINE THE NON-CONDUCTIVE VALUES
OF DIFFERENT MATERIALS.

(H. F. Donaldson, M.I.C.E., *Proceedings, Inst. C.E.*)

EXPERIMENT NO. 1.

| | Thickness of Insulating Material. | Original Weight of Ice. | Weight after | | Loss after Seventy-two Hours. |
|---|--|-------------------------------|-----------------------|-----------------------|-------------------------------------|
| | | | Twenty-four Hours. | Seventy-two Hours. | |
| | Inches. | Oz. | Oz. | Oz. | Per cent. |
| Peat (compressed and set in fossil meal) - | 9 | 95 | 81 | 59 | 37·89 |
| Charcoal - - - | 11 | 96½ | 79½ | 56 | 41·97 |
| Silicate cotton - - | 4½ | 92½ | 73½ | 40½ | 56·21 |
| Magnesia and asbes- tos fibre - - - | 4½ | 93 | 73 | 40½ | 56·45 |

NOTE.—The author thought it undesirable to consider further compressed peat set in fossil meal, as he found by experiment its powers of absorption of moisture to be so great as to constitute in his opinion a source of danger.

EXPERIMENT NO. 2.

| | Thickness of Insulating Material. | Original Weight of Ice. | Weight after | | | Loss after Ninety-six Hours. |
|-------------------|--|----------------------------------|---------------------------|---------------------------|--------------------------|------------------------------------|
| | | | Twenty- four Hours. | Forty- eight Hours. | Ninety- six Hours. | |
| | Inches. | Oz. | Oz. | Oz. | Oz. | Per cent. |
| Silicate cotton - | 6 | 104 | 88¾ | 76¾ | 58½ | 43·75 |
| Sawdust - - - | 9 | 103½ | 86½ | 71 | 48 | 52·62 |
| Peat - - - - | 9 | 104 | 77½ | 56 | 26½ | 74·75 |
| Charcoal - - - | 9 | 104 | 88¾ | 78½ | 60½ | 41·82 |

RESULTS OF TESTS—*continued.*

EXPERIMENT No. 3.

| | Thickness of Insulating Material. | Original Weight of Ice. | Weight after | | Loss after Seventy-two Hours. |
|-----------------------|-----------------------------------|-------------------------|--------------------|--------------------|-------------------------------|
| | | | Twenty-four Hours. | Seventy-two Hours. | |
| | Inches. | Oz. | Oz. | Oz. | Oz. |
| Silicate cotton - - - | 9 | 92 | 83 $\frac{3}{4}$ | 72 $\frac{1}{2}$ | 21.19 |
| Charcoal - - - | 11 | 92 | 82 $\frac{3}{4}$ | 70 $\frac{1}{2}$ | 23.36 |

EXPERIMENT No. 4.

| | Thickness of Insulating Material. | Original Weight of Ice. | Weight after | | Loss after Ninety-six Hours. |
|----------------------------------|-----------------------------------|-------------------------|--------------------|-------------------|------------------------------|
| | | | Twenty-four Hours. | Ninety-six Hours. | |
| | Inches. | Oz. | Oz. | Oz. | Per cent. |
| Silicate cotton (loosely packed) | 9 | 110 | 103 | 84 $\frac{1}{2}$ | 23.41 |
| Silicate cotton - - - | 9 | 110 | 101 $\frac{3}{4}$ | 80 $\frac{3}{4}$ | 26.59 |
| Charcoal - - - | 11 | 110 | 100 $\frac{1}{2}$ | 79 | 28.18 |
| Vegetable silica - - - | 11 | 110 | 101 $\frac{1}{2}$ | 76 $\frac{3}{4}$ | 30.22 |
| Diatomite - - - | 11 | 110 | 99 | 73 $\frac{1}{2}$ | 32.95 |

RESULTS OF TESTS TO DETERMINE THE NON-CONDUCTIVE VALUES OF VARIOUS MATERIALS.

(Dr Wm. Wallace.)

| Materials. | Cubic Centimetres (grammes) of Water Melted in 12 Days. | Average c.c.'s per Day. |
|--------------------------------|---|-------------------------|
| Silicate cotton - - - - - | 9,470 | 789 |
| Flake charcoal - - - - - | 11,010 | 917 |
| Felt - - - - - | 11,760 | 980 |
| Fossil meal - - - - - | 12,530 | 1,044 |
| Twig charcoal - - - - - | 13,590 | 1,132 |
| Plain cork slabs - - - - - | 14,020 | 1,168 |
| Tarred cork slabs - - - - - | 14,610 | 1,217 |
| Broken lump charcoal - - - - - | 15,916 | 1,326 |
| Ashes - - - - - | 23,316 | 1,943 |

Coleman's method was used in making the above tests, with walls 6 in. thick.

RATE OF PASSAGE OF HEAT THROUGH VARIOUS MATERIALS.
(*Alex. Marcet.*)

British Thermal Units per hour per superficial foot through materials 6 in. thick.

| | T=60° | | T=50° | | T=40° | |
|----------------------|-------|-------|-------|------|-------|------|
| | Dry. | Wet. | Dry. | Wet. | Dry. | Wet. |
| Silicate cotton - - | 4.11 | 14.05 | 2.34 | 8.57 | 1.17 | 6.70 |
| Cow hair - - - | 4.11 | 8.80 | 2.34 | 5.30 | 1.17 | 3.50 |
| Charcoal - - - | 4.70 | 12.30 | 2.93 | 7.50 | 1.76 | 4.40 |
| Sawdust - - - | 6.75 | 15.60 | 4.40 | 9.60 | 2.34 | 5.50 |
| Infusorial earth - - | 10.00 | ... | 6.18 | ... | 3.57 | ... |
| Cork bricks - - | 5.87 | ... | 3.20 | ... | 2.90 | ... |

T = Difference of Temperature (Fahr.) on the two sides of the material.

RESULTS OF TESTS ON THE HEAT CONDUCTIVITY OF DIFFERENT SUBSTANCES.

(*Various authorities.*)

(Silicate Cotton being taken at 100.)

| Substances. | C. E. Emery, 1881. | J. J. Coleman, 1884. | W. H. Collins, 1891. | Prof. Jamieson, 1894. |
|------------------------------------|--------------------|----------------------|----------------------|-----------------------|
| Silicate cotton or slag-wool - | 100 | 100 | 100 | 100 |
| Hair-felt or fibrous composition - | ... | 117 | 114 | 112 |
| Papier-mâché - - - - | ... | ... | 147 | 111 |
| Kieselguhr composition - - - | ... | 136 | ... | 112 |
| Sawdust - - - - - | 122 | 163 | 142 | ... |
| Charcoal - - - - - | 132 | 140 | ... | ... |
| Cotton wool - - - - - | ... | 122 | ... | ... |
| Sheep's wool - - - - - | ... | 136 | ... | ... |
| Pine wood (across the grain) - | 150 | ... | ... | ... |
| Loam - - - - - | ... | ... | ... | ... |
| Gasworks breeze or coal ashes - | 240 | 230 | 299 | ... |
| Asbestos - - - - - | 229 | ... | 179 | ... |

TABLE GIVING THE RELATIVE HEAT CONDUCTIVITY OF VARIOUS BOILER-COVERING MATERIALS.

(The "American Engineer.")

| | | | | | | |
|---------------------------------|---|---|---|---|---|-----|
| Silicate cotton or mineral wool | - | - | - | - | - | 100 |
| Hair-felt | - | - | - | - | - | 117 |
| Cotton wool | - | - | - | - | - | 122 |
| Sheep's wool | - | - | - | - | - | 136 |
| Infusorial earth | - | - | - | - | - | 136 |
| Charcoal | - | - | - | - | - | 140 |
| Sawdust | - | - | - | - | - | 163 |
| Gasworks breeze | - | - | - | - | - | 230 |
| Wood and air space | - | - | - | - | - | 280 |

RESULTS OF EXPERIMENTS REGARDING NON-HEAT-CONDUCTING PROPERTIES OF VARIOUS SUBSTANCES.

(Professor J. M. Ordway.)

| Coverings 1 in. thick. | | Lbs. of Water heated 10° Fahr. per hour by 1 square foot. | |
|------------------------|-------------------------------------|---|------|
| * { | 1. "Silicate cotton" or "slag-wool" | 13.0 | |
| | 2. Paper | 14.0 | |
| | 3. Cork strips, bound on | 14.6 | |
| | 4. Straw rope, wound spirally | 18.0 | |
| | 5. Loose rice chaff | 18.7 | |
| | 6. Blotting paper, wound tight | 21.0 | |
| | 7. Paste of fossil meal and hair | 16.7 | |
| | † { | 8. Loose bituminous coal ashes | 21.0 |
| | | 9. Paste of fossil meal with asbestos | 22.0 |
| | | 10. Loose anthracite coal ashes | 27.0 |
| | | 11. Paste of clay and vegetable fibre | 30.9 |
| | | 12. Dry plaster of paris | 30.9 |
| | | 13. Asbestos paper, wound tight | 21.7 |
| | | 14. Air alone | 48.0 |
| | | 15. Fine asbestos | 49.0 |
| | | 16. Sand | 62.1 |

N.B.—The asbestos of 15 had smooth fibres, which could not prevent the air from moving about. Later trials with an asbestos of exceedingly fine fibre have made a somewhat better showing, but asbestos is really one of the poorest non-conductors. By reason of its fibrous character it may be used advantageously to hold together other incombustible substances, but the less the better.

* These substances are not well suited for covering heated surfaces—owing to their nature they soon become carbonised.

† Hard substances that, with the action of the heat, break, powder, and fall off.

NON-HEAT-CONDUCTING PROPERTIES OF VARIOUS SUBSTANCES.

(From "Engineering.")

| Prepared Mixtures, for Covering Boilers, Pipes, &c. | Lbs. of Water heated 10° Fahr. per hour per square foot. |
|---|--|
| Slag-wool (silicate cotton) and hair paste - | 10.0 |
| Fossil meal and hair paste - - - - | 10.4 |
| Paper pulp alone - - - - - | 14.7 |
| Asbestos fibre, wrapped tightly - - - | 17.9 |
| Fossil meal and asbestos powder - - - | 26.3 |
| Coal ashes and clay paste, wrapped with straw | 29.9 |
| Clay, dung, and vegetable fibre paste - | 39.6 |
| Paper pulp, clay, and vegetable fibre - - | 44.6 |

RESULTS OF EXPERIMENTS REGARDING NON-HEAT-CONDUCTING PROPERTIES OF VARIOUS SUBSTANCES.

(Walter Jones, "Heating by Hot Water.")

| Frame Filled with | Left for | Highest Temperature Registered. |
|---------------------------------------|----------|---------------------------------------|
| Leroy's boiler-covering composition - | 3 hours | 94° |
| Asbestos powder - - - - - | 4 " | 86° |
| Hair-felt - - - - - | 9 " | 77° |
| Silicate cotton - - - - - | 9 " | 76° |

The quantity of heat in units, transmitted through 1 sq. ft. of plate per hour, may be found thus:—Subtract the temperature of the cooler side from that of the hotter side of the plate, then multiply the result by the number in the preceding table corresponding to the material used, and divide the product by the thickness of plate. Thus an iron plate 2 in. thick, having a temperature of 60° on one side and 80° on the other, will transmit $80 - 60 = \frac{20 \times 230}{2} = 2,300$ units of heat per square foot per hour.

HEAT-CONDUCTING POWER OF VARIOUS SUBSTANCES,
SLATE BEING 1,000.

(*Molesworth.*)

| | | | |
|--------------------------|---------|----------------------------|-----|
| Slate - - - - - | 1,000 | Chalk - - - - - | 564 |
| Lead - - - - - | 5,210 | Asphalte - - - - - | 451 |
| Flagstone - - - - - | 1,110 | Oak - - - - - | 336 |
| Portland stone - - - - - | 750 | Lath and plaster - - - - - | 255 |
| Brick - - - - - | 600-730 | Cement - - - - - | 200 |
| Fire-brick - - - - - | 620 | | |

EXPERIMENTS ON HEAT CONDUCTIVITY OF SLAG-WOOL AND CHARCOAL.

(*T. B. Lightfoot, M.Inst. C.E., G. A. Becks, A.M.Inst. C.E., in 1885.*)

EXPERIMENT No. 1.

Began 11.30 A.M., 2nd June.

Ended 11.30 A.M., 4th June.

Duration of experiment, forty-eight hours.

Average temperature of room or chamber, 90° Fahr.

A piece of ice 23 lbs. in weight was placed in a zinc box 12 in. cube, and covered with 2 in. silicate cotton, this latter being provided with an outer cover, also of zinc.

When the ice was taken out it weighed 10½ lbs., showing a loss of 12½ lbs.

12½ lbs. × 142 (latent heat of ice) = 1775 thermal units passed through in forty-eight hours.

48) 1775 (36.9 thermal units passed through in one hour.

Difference in temperature between inner box and outer air = 58° Fahr.

36.9

58 = 0.63 thermal unit transmitted per hour per degree difference

in temperature.

Area of zinc boxes :—

| | |
|------------------------|-----------|
| Inner box - - - - - | 6 sq. ft. |
| Outer casing - - - - - | 10.6 „ „ |
| Mean - - - - - | 8.1 „ „ |

Thermal units transmitted through the three areas =

| | | |
|--------|----------|-----------|
| 6) .63 | 8.1) .63 | 10.6) .63 |
| .105 | .07 | .059 |

which being multiplied by 2 for the thickness of cotton, gives thermal units per hour, per degree difference in temperature, per square foot, per inch of thickness, as follows:—

- 210 inner tin.
- 118 outer tin.
- 14 mean between the two.

EXPERIMENT No. 2.

Began 11.30 A.M., 2nd June.

Ended 11.30 A.M., 4th June.

Duration, forty-eight hours.

Average temperature of room, 90° Fahr.

A piece of ice 26 lbs. in weight, covered with 6 in. of charcoal.

When taken out it weighed 7½ lbs., showing a loss of 18½ lbs.

$18.5 \times 142 = 2627$ thermal units in forty-eight hours.

$$\frac{2627}{48} = 54.72 \text{ thermal units per hour.}$$

$$\frac{54.72}{58} = .94 \text{ thermal unit per hour, per degree difference in tem-}$$

perature between inner box and outer air.

Area of tins:—

| | | | | | | |
|--------------|---|---|---|---|---|-----------|
| Inner box | - | - | - | - | - | 6 sq. ft. |
| Outer casing | - | - | - | - | - | 24 „ „ |
| Mean | - | - | - | - | - | 13.5 „ „ |

The number of thermal units transmitted per hour, per degree, per square foot =

$$\begin{array}{r} 6 \cdot 94 \\ \hline \cdot 15 \end{array} \qquad \begin{array}{r} 13.5 \cdot 94 \\ \hline \cdot 069 \end{array} \qquad \begin{array}{r} 24 \cdot 94 \\ \hline \cdot 039 \end{array}$$

which being multiplied by 6 for the thickness of charcoal =

$$\left. \begin{array}{l} \cdot 90 \text{ inner tin} \\ \cdot 234 \text{ outer tin} \\ 4.14 \text{ mean} \end{array} \right\} \begin{array}{l} \text{Thermal units transmitted per hour,} \\ \text{per degree, per square foot, per inch of} \\ \text{thickness.} \end{array}$$

TABLE *

SHOWING TRANSMISSION OF HEAT THROUGH VARIOUS INSULATING STRUCTURES (*Starr*).

Col. I. gives B.T.U. per square foot per day per degree of difference of temperature. Col. II. gives meltage of ice in pounds per day by heat coming through 100 sq. ft. at a difference of 40°.

| | Col. I. | Col. II. |
|---|---------|----------|
| $\frac{5}{8}$ -in. oak—paper. 1 in. lampblack, $\frac{3}{8}$ -in. pine. (This is the ordinary small stock family refrigerator)- | 5.7 | 160.7 |
| One $\frac{7}{8}$ -in. board, 1 in. pitch, one $\frac{3}{8}$ -in. board | 4.90 | 138 |
| Four $\frac{7}{8}$ -in. spruce boards, two papers, solid, no air space | 4.28 | 120 |
| Two double boards and paper (four $\frac{7}{8}$ -in. boards) and one air space | 3.71 | 105 |
| One $\frac{7}{8}$ -in. board, 2 in. pitch, one $\frac{3}{8}$ -in. board | 4.25 | 119.7 |
| One $\frac{7}{8}$ -in. board, 2½ in. mineral wool, paper, one $\frac{3}{8}$ -in. board | 3.62 | 101.9 |
| Two $\frac{7}{8}$ -in. double boards and two papers, 1 in. hair-felt | 3.318 | 93.4 |
| Two $\frac{7}{8}$ -in. boards and paper, 1 in. sheet cork, two $\frac{3}{8}$ -in. boards and paper | 3.30 | 92.9 |
| One $\frac{7}{8}$ -in. board, paper, 2 in. calcined pumice, paper and $\frac{7}{8}$ -in. board | 3.38 | 95.2 |
| Four double $\frac{7}{8}$ -in. boards with paper between (eight boards) and three 8-in. air spaces | 2.7 | 76 |
| Hair quilt insulator, four boards, four quilts, hair | 2.51 | 70.9 |
| One 7 in. board, 6 in. patent silicated strawboard, air cell finished inside with thin layer patent cement | 2.48 | 69.8 |
| One $\frac{7}{8}$ -in. board, paper, 3 in. sheet cork, paper, one $\frac{7}{8}$ -in. board | 2.10 | 60 |
| Two $\frac{7}{8}$ -in. boards and paper, 8 in. mill shavings and paper, two $\frac{7}{8}$ -in. boards and paper | 1.35 | 38.3 |
| Same slightly moist | 1.80 | 50.7 |
| Same damp | 2.10 | 60 |
| Double boards and paper, 1 in. air, 4 in. sheet cork, paper, one $\frac{7}{8}$ -in. board | 1.20 | 33.6 |
| Same, with 5 in. sheet cork | .90 | 25.3 |
| $\frac{7}{8}$ -in. board, paper, 1 in. mineral wool, paper, $\frac{7}{8}$ -in. board | 4.6 | 130 |
| Double boards and papers, 4 in. granulated cork, double boards and paper | 1.7 | 48 |

EXPERIMENTS ON THE TRANSMISSION OF HEAT THROUGH NON-CONDUCTING MATERIALS.

The following results, according to *Il Politecnico*, Milan, were obtained by Mr Maurs from a series of experiments upon the transmission of heat through various materials used at the present time for

* "Insulation for Cold Storage." Paper read before the Eleventh Annual Convention of the American Warehousemen's Association at Buffalo, N.Y., October 1901.

insulating purposes in refrigeration. According to the author there existed an incertitude on the subject of the coefficients of the transmission of heat through various insulating materials. In carrying out the experiments, he employed a cubical receptacle or container having double walls, the space or clearance between which walls was filled with the insulating material to be tested, and a known quantity of ice was placed within the receptacle and the amount melted in a given time ascertained. In this manner he obtained a coefficient *K* for the transmission of heat which expresses the number of units of heat passing through the insulating material per hour, per degree of difference of temperature, between the opposite surfaces per square metre of these surfaces, the distance being one metre. This coefficient expresses conjointly a number of complex phenomena, viz., the absorption of heat, conductivity, convection on the exterior, &c. These phenomena, however, are always present in the use of insulating materials, and it is sufficient that the coefficient *K* be established for all the materials under uniform conditions. The following are the coefficients that were found for *K* for the following materials:—Cork in powder, 0·048; cork in pieces, 0·041; wad of silk flock, 0·041; wad of silk fibre, 0·043; cotton, 0·045; husks of rice, 0·050; deal sawdust, 0·066; fibrous peat, 0·063; peat in pieces, 0·065; peat in powder, 0·082.

WATERPROOF COATINGS FOR BRICK SURFACES.*

“During the summer of 1899 a large variety of paints, oils, varnishes, cements, and so-called waterproof coatings were tested for a cold storage company in the hope of finding some coating that would make waterproof and airproof the brick walls of its warehouses. The tests were made with quarter bricks with good, fair surfaces, free from large holes, and, as nearly as possible, like those used in the exterior walls. Quarter bricks were used instead of whole bricks, so that sensitive balances could be used for the different weighings. All weighings were made to within one-thousandth of a gram. The results of the more satisfactory tests are tabulated below, and besides these, many other tests were made, but these other tests were either unsatisfactory or the materials tested of no value for the desired use. The quarter bricks to be tested were immersed in water of a temperature of

* Extract from paper by Mr Stoddard, read before the Eleventh Annual Convention of the American Warehousemen's Association at Buffalo, N. Y., October 1901.

about 70°, the brick being placed on its side, and there being 1 in. of water over the brick. Weighings were made as follows:—

| | | | |
|-------------------------------|---|---|-----------|
| “Of the brick before coating. | | | |
| Of the brick after coating. | | | |
| Of the brick after immersion | - | - | 24 hours. |
| ” | ” | - | 48 ” |
| ” | ” | - | 72 ” |
| ” | ” | - | 96 ” |
| ” | ” | - | 120 ” |

“At the end of each twenty-four hour period the quarter bricks were taken from the water, the outer surfaces carefully dried by cloth and blotting paper, and then the bricks were immediately weighed before any evaporation could take place from the pores of the brick. This was repeated in most of the tests until the bricks had been immersed for a period of 120 hours. After this continued immersion the bricks were taken from the water and their surfaces examined in order to see what change, if any, had taken place in the coating. In some cases the coating had softened, in some shrivelled, and in one case the coating, naphtha and a paraffin-like substance, which before immersion was evidently well into the pores of the brick, had gradually worked out into the water.

“The nature of the substances tested varied greatly. Some were in the nature of paints and varnishes, and were retained mostly upon the surfaces of the bricks. To this class belonged the materials used in tests marked A, B, D, G, L, O, P, and Q. Other substances were more in the nature of a paste or coating applied upon the surface of the bricks. In this class may be included the substances used in tests marked C, I, K, N, R, S, T, and U. Another class of substances was supposed to soak into the bricks, and by filling the pores exclude moisture. To this class belonged the substances used in tests E, F, and J. Other coatings consisted of two substances, which, when combined, were supposed to form an insoluble compound or compounds which would fill up the pores of the brick. The tests of this class are marked H, M, and V.

“Some substances which were submitted for test could be applied to the bricks only by soaking, and so were not available. Some bricks offered for test were soaked full of the so-called waterproofing, and of course would not absorb water or anything else while in that condition, as the pores of the brick were already filled. Many resins, gums, and oils were tested, but they were of no practical use.

“Pitch, asphaltum, &c., were objectionable, because of their odour and colour. The results of the tests giving the most favourable results are shown in the following tables.

TESTS OF WATERPROOFING BRICK.

| 1 | 2 | 3 | 4 | 5 | 11 | 12 |
|------------|---------------|---------------|----------|-------------------------|--|------------------------------|
| Sample. | Weight—Grams. | | | Compared to Bare Brick. | | |
| | Bare Brick. | Coated Brick. | Coating. | Per Cent. Increase. | Per Cent. Increase by Coating and Water. | Per Cent. Increase by Water. |
| A - - | 630·32 | 639·10 | 8·78 | 1·39 | 1·63 | 0·24 |
| B - - | 556·71 | 571·11 | 14·40 | 2·59 | 3·11 | 0·52 |
| C - - | 578·43 | 581·92 | 3·49 | 0·60 | 1·14 | 0·89 |
| D - - | 527·80 | 537·70 | 9·90 | 1·88 | 2·84 | 0·97 |
| E - - | 616·10 | 637·60 | 21·50 | 3·49 | 5·61 | 1·62 |
| F - - | 633·80 | 706·87 | 73·07 | 11·53 | 13·75 | 2·23 |
| G - - | 584·40 | 588·92 | 4·52 | 0·77 | 3·23 | 2·46 |
| H - - | 499·52 | 551·00 | 51·48 | 10·31 | 13·36 | 3·07 |
| I - - | 504·12 | 523·40 | 19·28 | 3·82 | 6·93 | 3·10 |
| J - - | 666·94 | 670·07 | 3·13 | 0·47 | 3·94 | 3·47 |
| K - - | 607·29 | 610·90 | 3·61 | 0·59 | 4·19 | 3·59 |
| L - - | 519·68 | 527·34 | 7·69 | 1·48 | 5·66 | 4·18 |
| M - - | 652·50 | 692·99 | 40·49 | 6·21 | 10·53 | 4·33 |
| N - - | 510·20 | 529·10 | 18·90 | 3·70 | 8·35 | 4·65 |
| O - - | 570·87 | 586·20 | 15·33 | 2·69 | 7·71 | 5·03 |
| P - - | 496·20 | 503·00 | 6·80 | 1·37 | 7·16 | 5·79 |
| Q - - | 502·87 | 515·12 | 12·25 | 2·44 | 8·85 | 6·37 |
| R - - | ... | 543·60 | ... | ... | ... | 1·32 |
| S - - | ... | 602·20 | ... | ... | Compared to coated brick. | 1·53 |
| T - - | ... | 606·31 | ... | ... | | 1·68 |
| U - - | ... | 581·16 | ... | ... | | 2·69 |
| V - - | ... | 621·85 | ... | ... | | 5·17 |
| W - - | ... | ... | ... | ... | | ... |
| X - - | ... | ... | ... | ... | ... | ... |
| Y - - | ... | ... | ... | ... | ... | ... |
| Bare brick | ... | 489·04 | ... | ... | ... | 8·68 |

TESTS OF WATERPROOFING BRICK.

| Sample. | 6 | 7 | 8 | 9 | 10 |
|--------------|--|-----------|-----------|-----------|------------|
| | Increased Weight by Absorption of Water. | | | | |
| | 24 Hours. | 48 Hours. | 72 Hours. | 96 Hours. | 120 Hours. |
| A - - - | 0·30 | ... | 1·10 | ... | 1·50 |
| B - - - | 1·39 | ... | 2·16 | 2·49 | 2·89 |
| C - - - | 1·15 | 2·18 | 3·25 | 3·49 | 5·13 |
| D - - - | 1·00 | ... | 2·88 | 4·00 | 5·10 |
| E - - - | 2·10 | 5·55 | 7·15 | ... | 9·97 |
| F - - - | 4·75 | 12·13 | 12·83 | ... | 14·13 |
| G - - - | 4·88 | 7·48 | 9·68 | 11·43 | 14·38 |
| H - - - | 7·30 | 9·70 | 11·30 | 13·30 | 15·32 |
| I - - - | 3·73 | 6·33 | ... | 12·12 | 15·63 |
| J - - - | 20·33 | 21·13 | 21·63 | 23·13 | ... |
| K - - - | 7·00 | 8·60 | 9·30 | ... | 21·83 |
| L - - - | 3·73 | 5·78 | ... | 12·68 | 21·72 |
| M - - - | 24·78 | ... | 27·16 | ... | 28·24 |
| N - - - | 23·10 | ... | 23·80 | ... | 23·72 |
| O - - - | 26·98 | 28·00 | 28·00 | ... | 23·70 |
| P - - - | 24·85 | ... | 28·75 | 28·71 | 28·72 |
| Q - - - | 29·08 | 36·70 | 31·28 | ... | 32·03 |
| R - - - | 3·72 | 5·00 | 6·15 | 7·15 | ... |
| S - - - | 3·10 | 5·55 | 7·35 | 9·20 | ... |
| T - - - | 2·35 | 4·69 | 8·07 | 10·21 | ... |
| U - - - | 6·46 | 9·69 | 12·69 | 15·64 | ... |
| V - - - | 21·15 | 29·60 | 31·02 | ... | 32·15 |
| W - - - | ... | ... | ... | ... | ... |
| X - - - | ... | ... | ... | ... | ... |
| Y - - - | ... | ... | ... | ... | ... |
| Bare brick - | 21·26 | ... | 39·69 | 39·69 | 42·43 |

TESTS OF WATERPROOFING BRICK.

| 1 | 2 | 3 | 4 | 5 | 6 | 7 | 8 | 9 | 10 | 11 | 12 |
|------------|---------------|---------------|----------|---------------------|--|-----------|-----------|-----------|------------|--------------------------------------|--------------------------|
| | Weight—Grams. | | | | Increase in Weight by Absorption of Water. | | | | | Compared to Bare Brick. | |
| Sample. | Bare Brick. | Coated Brick. | Coating. | Per Cent. Increase. | 24 Hours. | 48 Hours. | 72 Hours. | 96 Hours. | 120 Hours. | Per Cent. Inc. by Coating and Water. | Per Cent. Inc. by Water. |
| A - | 630.32 | 639.10 | 8.78 | 1.39 | 0.30 | ... | 1.10 | ... | 1.50 | 1.63 | 0.24 |
| B - | 556.71 | 571.11 | 14.40 | 2.59 | 1.39 | ... | 2.16 | 2.49 | 2.89 | 3.11 | 0.52 |
| C - | 578.43 | 581.92 | 3.49 | 0.60 | 1.15 | 2.18 | 3.25 | 3.49 | 5.13 | 1.14 | 0.89 |
| D - | 527.80 | 537.70 | 9.90 | 1.88 | 1.00 | ... | 2.88 | 4.00 | 5.10 | 2.84 | 0.97 |
| E - | 616.10 | 637.60 | 21.50 | 3.49 | 2.10 | 5.55 | 7.15 | ... | 9.99 | 5.11 | 1.62 |
| F - | 633.80 | 706.87 | 73.07 | 11.53 | 4.75 | 12.13 | 12.83 | ... | 14.13 | 13.75 | 2.23 |
| G - | 584.40 | 588.92 | 4.52 | 0.77 | 4.88 | 7.48 | 9.68 | 11.43 | 14.38 | 3.23 | 2.46 |
| H - | 499.52 | 551.00 | 51.48 | 10.31 | 7.30 | 9.70 | 11.30 | 13.30 | 15.32 | 13.36 | 3.07 |
| I - | 504.12 | 523.40 | 19.28 | 3.82 | 3.73 | 6.33 | ... | 12.12 | 15.63 | 6.93 | 3.10 |
| J - | 666.94 | 670.07 | 3.13 | 0.47 | 20.33 | 21.13 | 21.63 | 23.13 | ... | 3.94 | 3.47 |
| K - | 607.29 | 610.90 | 3.61 | 0.59 | 7.00 | 8.60 | 9.30 | ... | 21.83 | 4.19 | 3.59 |
| L - | 519.68 | 527.34 | 7.69 | 1.48 | 3.76 | 5.78 | ... | 12.68 | 21.72 | 5.66 | 4.18 |
| M - | 652.50 | 692.99 | 40.49 | 6.21 | 24.78 | ... | 27.16 | ... | 28.24 | 10.53 | 4.33 |
| N - | 510.20 | 529.10 | 18.90 | 3.70 | 23.10 | ... | 23.80 | ... | 23.72 | 8.35 | 4.65 |
| O - | 570.87 | 586.20 | 15.33 | 2.69 | 26.98 | 28.00 | 28.00 | ... | 28.70 | 7.71 | 5.03 |
| P - | 496.20 | 503.00 | 6.80 | 1.37 | 24.85 | ... | 28.75 | 28.71 | 28.72 | 7.16 | 5.79 |
| Q - | 502.87 | 515.12 | 12.25 | 2.44 | 29.08 | 30.70 | 31.28 | ... | 32.03 | 8.85 | 6.37 |
| R - | ... | 543.60 | ... | ... | 3.72 | 5.00 | 6.15 | 7.15 | ... | ... | *1.32 |
| S - | ... | 602.20 | ... | ... | 3.10 | 5.55 | 7.35 | 9.20 | ... | ... | *1.53 |
| T - | ... | 606.31 | ... | ... | 2.35 | 4.69 | 8.07 | 10.21 | ... | ... | *1.68 |
| U - | ... | 581.16 | ... | ... | 6.46 | 9.69 | 12.69 | 15.64 | ... | ... | *2.69 |
| V - | ... | 621.85 | ... | ... | 21.15 | 29.60 | 31.02 | ... | 32.15 | ... | *5.17 |
| W - | ... | ... | ... | ... | ... | ... | ... | ... | ... | ... | ... |
| X - | ... | ... | ... | ... | ... | ... | ... | ... | ... | ... | ... |
| Y - | ... | ... | ... | ... | ... | ... | ... | ... | ... | ... | ... |
| Bare brick | 489.04 | ... | ... | ... | 21.26 | ... | 39.69 | 39.69 | 42.43 | ... | *8.68 |

1 gram equals 15.43 grains ; 28.35 grams equals 1 ounce avoirdupois.

* Compared to coated brick.

KEY TO TESTS OF WATERPROOFING BRICK.

| | | | | |
|---|------------|------|---|-------------|
| A.—Bay State air and waterproofing - | - | - | - | 3 coats. |
| B.—Red mineral paint, ground in oil | - | - | - | 2 coats. |
| C.—Spar varnish with plaster of paris | - | - | - | 2 coats. |
| D.—Spar varnish | - | - | - | 2 coats. |
| E.—New York sample, No. 2 | - | - | - | Soaked. |
| F.—New York sample, No. 1 | - | - | - | Soaked. |
| G.—Shellac | - | - | - | 1 coat. |
| H.—Portland cement, 1 coat ; soap and alum, 3 coats | - | - | - | 4 coats. |
| I.—White enamel paint | - | - | - | 3 coats. |
| J.—Paraffin in naphtha | - | - | - | 3 coats. |
| K.—Hot paraffin | - | - | - | 3 coats. |
| L.—Water paint | - | - | - | 3 coats. |
| M.—Portland cement mixed with CaCl_2 , 1 coat ; water glass, | | | | |
| 3 coats | - | - | - | 4 coats. |
| N.—Portland cement | - | - | - | 2 coats. |
| O.—Black varnish, No. 2 | - | - | - | 3 coats. |
| P.—Spar varnish | - | - | - | 1 coat. |
| Q.—Black varnish, No. 1 | - | - | - | 3 coats. |
| R.—Waterproofing, No. 1. | | | | |
| (A putty-like substance applied to surface of brick.) | | | | |
| S.—Waterproofing, No. 4. | Similar to | "R." | | |
| T.—Waterproofing, No. 3. | Similar to | "R." | | |
| U.—Waterproofing, No. 2. | Similar to | "R." | | |
| V.—Bi-chromate potash and glue—exposed to sunlight. | | | | |
| Bare brick | - | - | - | No coating. |

"In regard to the result of the tests it is worthy of remark that some of the substances that have been considered as among the best waterproof materials proved to be either of little value or very inferior to some of the other substances.

"The Sylvester process, H, soap and alum, proved to be of little value, even when applied to a surface made as smooth as possible with Portland cement. This process was also tried without the cement, but was even less effective. Hot paraffin has often been used to waterproof walls; but, under the conditions of these tests, it proved to be very far from waterproof. Portland cement is another substance which did not prove to be as good as its reputation."

WALLS FOR COLD STORES.

The following materials and dimensions have been used and are recommended for walls of cold chambers:—

Walls at the St Katherine's Dock, London, were formed of up-

rights, $5\frac{1}{2}$ in. by 3 in., fixed upon the floor joists or bearers, and having an outer and an inner skin attached thereto; the former consisting of 2-in. boards, and the latter of two thicknesses or layers of $1\frac{1}{4}$ -in. boards, with an intermediate layer of specially-prepared brown paper. The $5\frac{1}{2}$ in. clearance or space between the inner and outer skins of the walls and roof was likewise filled with wood charcoal, carefully dried.

14 in. brick wall, $3\frac{1}{2}$ in. air space, 9 in. brick wall, 1 in. layer of cement, 1 in. layer of pitch, 2 in. by 3 in. studding, layer of tar paper, 1-in. tongued and grooved boarding, 2 in. by 4 in. studding, 1-in. tongued and grooved board, layer of tar paper, and, finally, 1-in. tongued and grooved boarding, the total thickness of these layers or skins being 3 ft. 3 in.

36 in. brick wall, 1 in. layer of pitch, 1 in. sheathing, 4 in. air space, 2 in. by 4 in. studding, 1 in. sheathing, 3 in. layer of mineral or slag wool, 2 in. by 4 in. studding, and, finally, 1 in. sheathing; total thickness, 4 ft. 7 in.

14 in. brick wall, 4 in. pitch and ashes, 4 in. brick wall, 4 in. air space, 14 in. brick wall; total thickness, 3 ft. 4 in.

14 in. brick wall, 6 in. air space, double thickness of 1-in. tongued and grooved boards, with a layer of waterproof paper between them, 2 in. layer of the best quality hair felt, second double thickness of 1-in. tongued and grooved boards, with a similar layer of paper between them; total thickness, 2 ft. 2 in.

14 in. brick wall, 8 in. layer of sawdust, double thickness of 1-in. tongued and grooved boards, with a layer of tarred waterproof paper between them, 2 in. layer of hair-felt, second double thickness of 1-in. tongued and grooved boards, with a similar layer of paper between them; total thickness, 2 ft. $4\frac{1}{2}$ in.

Brick wall, 3 in. scratched hollow tiles, 4 in. silicate cotton or slag-wool, 3 in. scratched hollow tiles, and layer of cement plaster.

Brick wall, 1 in. air spaces between fillets of strips, 1-in. tongued and grooved boarding, two layers of insulating paper, 1-in. tongued and grooved boarding, 2 in. by 4 in. studs, 16 in. apart, spaces filled in with silicate cotton, 1-in. tongued and grooved boarding, two layers of insulating paper, air spaces between fillets, or strips 1 in. by 2 in. spaced 16 in. apart from centres, 1-in. tongued and grooved boarding, two layers of insulating paper, and 1-in. tongued and grooved boarding.

Brick or stone wall, well coated on inside with pitch or asphaltum, 2 in. by 3 in. studding, 24 in. centres, spaces between filled in with silicate cotton, $\frac{3}{4}$ -in. rough tongued and grooved boarding, two layers

waterproof insulating paper, $\frac{3}{4}$ -in. rough tongued and grooved boarding, 2 in. by 3 in. studding, 24 in. centres, in spaces between, $\frac{3}{4}$ -in. rough tongued and grooved boarding, two layers of waterproof insulating paper, $\frac{3}{4}$ -in. rough tongued and grooved boarding, 2 in. by 3 in. studding, 24 in. centres, spaces between filled in with silicate cotton, $\frac{3}{4}$ -in. rough tongued and grooved boarding, two layers of waterproof insulating paper, and $\frac{3}{4}$ -in. tongued and grooved match-boarding. Paper to be laid one-half lap and cemented at all joints.

Brick wall, 2 in. air space, 2 in. thicknesses of tongued and grooved boards with three layers of paper between, 2 in. air space, 2 in. thicknesses of tongued and grooved boards with three layers of paper between, 2 in. air space and 2 in. thicknesses of tongued and grooved boards with three layers of paper between.

Brick wall, well coated with pitch, 2 in. air space, 2 in. thicknesses of tongued and grooved boards with three layers of paper between, 2 in. space filled with slag-wool or cork, 2 in. thicknesses of tongued and grooved boards, with three layers of paper between, 2 in. space filled with slag-wool or cork, 2 in. thicknesses of tongued and grooved boards, with three layers of paper between. Shelving should be fixed horizontally in the spaces packed with slag-wool or cork at about 16 in. apart.

Brick wall, 1 in. air space, $\frac{3}{4}$ -in. match-boarding, 9 in. slag-wool or silicate cotton, layer of insulating paper and $\frac{3}{4}$ -in. match-boarding.

Brick wall, 1 in. air space, 6 in. slag-wool or silicate cotton, 1 in. silicate of cotton slab, layer of insulating paper, $\frac{1}{2}$ in. air space, and $\frac{3}{4}$ -in. match-boarding.

Brick wall, 1 in. air space, 1 in. silicate of cotton slab, 4 in. silicate of cotton, 1 in. silicate of cotton slab, $\frac{1}{2}$ -in. air space, and $\frac{3}{4}$ -in. match-boarding.

Brick wall, well coated with pitch, 2 in. air space, $\frac{7}{8}$ -in. tongued and grooved boarding, two layers of paper, $\frac{7}{8}$ -in. tongued and grooved boarding, 4 in. slag-wool or silicate cotton, $\frac{7}{8}$ -in. tongued and grooved boarding, two layers of paper, $\frac{7}{8}$ -in. tongued and grooved boarding, 2 in. air space, $\frac{7}{8}$ -in. tongued and grooved boarding, two layers of paper, and $\frac{7}{8}$ -in. tongued and grooved boarding.

Brick wall, 2 in. air space, $\frac{7}{8}$ -in. tongued and grooved boarding, two layers of paper, $\frac{7}{8}$ -in. tongued and grooved boarding, 2 in. air space, $\frac{7}{8}$ -in. tongued and grooved boarding, two layers of paper, and $\frac{7}{8}$ -in. tongued and grooved boarding.

Brick wall, 2 in. air space, $\frac{7}{8}$ -in. tongued and grooved boarding, one layer of paper, 4 in. slag-wool or silicate cotton, $\frac{7}{8}$ -in. tongued and

grooved boarding, one layer of paper, 4 in. air space, $\frac{7}{8}$ -in. tongued and grooved boarding, two layers of paper, and $\frac{7}{8}$ -in. tongued and grooved boarding.

Brick wall, layer of pitch, $\frac{7}{8}$ -in. tongued and grooved boarding 2 in. air space, $\frac{7}{8}$ -in. tongued and grooved boarding, one layer of paper, 3 in. cork dust, $\frac{7}{8}$ -in. tongued and grooved boarding, two layers of paper, and $\frac{7}{8}$ -in. tongued and grooved boarding.

Brick wall, $2\frac{1}{2}$ in. air space ventilated by air bricks every 5 ft. in all directions, 1-in. tongued and grooved boarding, layer of Willesden and brown paper, 1-in. tongued and grooved boarding, 12 in. charcoal supported by horizontal shelving 28 in. centres apart, 1-in. tongued and grooved boarding, two thicknesses of brown paper, and 1-in. tongued and grooved boarding.

Wall of cold storage room when made of wood: 2 in. thicknesses of tongued and grooved boarding with three layers of paper between, 2 in. air space, 2 in. thicknesses of tongued and grooved boarding with three layers of paper between, 2 in. air space, 2 in. thicknesses of tongued and grooved boarding with three layers of paper between, 2 in. air space, 2 in. thicknesses of tongued and grooved boarding with three layers of paper between, 8 in. slag-wool or silicate cotton, and 1-in. tongued and grooved boarding.

2 in. boards, $5\frac{1}{2}$ in. by 3 in. uprights, spaces between filled with carefully dried wood charcoal, $1\frac{1}{4}$ -in. boarding, layer of insulating paper, and $1\frac{1}{4}$ -in. boarding.

Outside siding, two layers of insulating paper, 1-in. tongued and grooved boarding, 2 in. by 6 in. studdings, 16 in. apart from centres, 1-in. tongued and grooved boarding, two layers of insulating paper, 1-in. tongued and grooved boarding, 2 in. by 4 in. studding 16 in. apart from centres, spaces filled in with silicate cotton, 1 in. tongued and grooved boarding, two layers of insulating paper, 2 in. by 2 in. fillets or strips 16 in. apart from centres, 1-in. tongued and grooved boarding, two layers of insulating paper, and 1-in. tongued and grooved boarding.

DIVISIONAL PARTITIONS FOR COLD STORES.

Tongued and grooved match-boarding, wire netting, 6 in. silicate of cotton or slag-wool, wire netting, tongued and grooved match-boarding. The object of the netting is to render the partition fire-proof by supporting the silicate of cotton after the match-boarding might have burnt away.

$\frac{3}{4}$ -in. match-boarding, $\frac{1}{2}$ in. air space, 1 in. silicate cotton slab,

4 in. of silicate of cotton or slag-wool, 1 in. silicate of cotton slab, $\frac{1}{2}$ -in. air space, and 1 in. silicate of cotton slab.

2 in. tongued and grooved boarding with three layers of paper between, 2 in. silicate of cotton or cork, 2 in. tongued and grooved boarding with three layers of paper between, 2 in. silicate of cotton or cork, 2 in. tongued and grooved boarding with three layers of paper between.

$\frac{7}{8}$ -in. tongued and grooved boarding, two layers of paper, $\frac{7}{8}$ -in. tongued and grooved boarding, 4 in. silicate cotton or slag-wool, $\frac{7}{8}$ -in. tongued and grooved boarding, 2 in. air space, $\frac{7}{8}$ -in. tongued and grooved boarding, two layers of paper, and $\frac{7}{8}$ -in. tongued and grooved boarding.

$\frac{7}{8}$ -in. tongued and grooved boarding, two layers of paper, $\frac{7}{8}$ -in. tongued and grooved boarding, 6 in. silicate of cotton or slag-wool, $\frac{7}{8}$ -in. tongued and grooved boarding, two layers of paper, $\frac{7}{8}$ -in. tongued and grooved boarding, 2 in. air space, $\frac{7}{8}$ -in. tongued and grooved boarding, two layers of paper, and $\frac{7}{8}$ -in. tongued and grooved boarding.

$\frac{7}{8}$ -in. tongued and grooved boarding, 2 in. silicate cotton or slag wool, $\frac{7}{8}$ -in. tongued and grooved boarding, 2 in. air space, $\frac{7}{8}$ -in. tongued and grooved boarding, two layers of paper, and $\frac{7}{8}$ -in. tongued and grooved boarding.

$\frac{7}{8}$ -in. tongued and grooved boarding, two layers of paper, $\frac{7}{8}$ -in. tongued and grooved boarding, 2 in. air space, $\frac{7}{8}$ -in. tongued and grooved boarding, two layers of paper, and $\frac{7}{8}$ -in. tongued and grooved boarding.

$\frac{7}{8}$ -in. tongued and grooved boarding, two layers of paper, $\frac{7}{8}$ -in. tongued and grooved boarding, 8 in. silicate cotton or slag-wool, $\frac{7}{8}$ -in. tongued and grooved boarding, two layers of paper, and $\frac{7}{8}$ -in. tongued and grooved boarding.

$\frac{7}{8}$ -in. tongued and grooved boarding, two layers of paper, $\frac{7}{8}$ -in. tongued and grooved boarding, 4 in. silicate cotton or slag-wool, $\frac{7}{8}$ -in. tongued and grooved boarding, two layers of paper, and $\frac{7}{8}$ -in. tongued and grooved boarding.

$\frac{7}{8}$ -in. tongued and grooved boarding, two layers of paper, $\frac{7}{8}$ -in. tongued and grooved boarding, 2 in. hair felt, $\frac{7}{8}$ -in. tongued and grooved boarding, 2 in. silicate cotton or slag-wool, $\frac{7}{8}$ -in. tongued and grooved boarding, two layers of paper, and $\frac{7}{8}$ -in. tongued and grooved boarding.

FLOORING FOR COLD STORES.

2 in. flooring, two layers of paper, $\frac{7}{8}$ -in. tongued and grooved boarding, 2 in. air space between fillets or scantlings, $\frac{7}{8}$ -in. tongued and grooved boarding, 12-in. joists, space between packed with silicate cotton or slag-wool, $\frac{7}{8}$ -in. tongued and grooved boarding, two layers of paper, $\frac{7}{8}$ -in. tongued and grooved boarding, 2 in. air space between fillets or scantlings, $\frac{7}{8}$ -in. tongued and grooved boarding, two layers of paper, and $\frac{7}{8}$ -in. tongued and grooved boarding.

2 in. cement, 3 in. concrete, $\frac{7}{8}$ -in. tongued and grooved boarding, two layers of paper, 2 in. flooring, 4 in. silicate cotton between fillets or scantlings, $\frac{7}{8}$ -in. tongued and grooved boarding, two layers of paper, 2 in. flooring boards on fillets or scantlings set in concrete.

2 in. asphalte, $\frac{7}{8}$ -in. tongued and grooved boarding, two layers of paper, $\frac{7}{8}$ -in. tongued and grooved boarding, 2 in. air space between scantlings, $\frac{7}{8}$ -in. tongued and grooved boarding, 3 in. silicate cotton or slag-wool between fillets or scantlings, $\frac{7}{8}$ -in. tongued and grooved boarding, 2 in. air space between fillets or scantlings, concrete.

1 in. asphalte, 2 in. concrete, $\frac{1}{2}$ in. pitch, 2 in. concrete, brick arches.

$1\frac{1}{4}$ -in. tongued and grooved flooring boards, layer of insulating paper, 2 in. by 9 in. joists 12 in. centres apart, spaces filled with silicate cotton or slag-wool, wire netting, layer of insulating paper, $\frac{3}{4}$ -in. match-boarding on 2 in. by 2 in. fillets or scantlings, air spaces between existing wooden or concrete flooring. The wire netting secured to the underside of the joists serves to retain the silicate cotton in case of fire.

1-in. tongued and grooved boarding, three layers of insulating paper, 1-in. tongued and grooved boarding, 2 in. by 9 in. joists, spaces between filled with silicate cotton or cork, 1-in. tongued and grooved boarding, three layers of insulating paper, and 1-in. tongued and grooved boarding.

$1\frac{1}{4}$ -in. tongued and grooved flooring boards, layer of insulating paper, 2 in. by 9 in. joists, 12 in. centres apart, spaces between filled in with silicate cotton or slag-wool, 1 in. silicate cotton slab on $\frac{1}{2}$ in. by 2 in. fillets, air spaces between, and $\frac{3}{4}$ -in. match-boarding. The 1 in. silicate of cotton slab is nailed on the underside of joists and is claimed to render the floor fire-proof, and to prevent radiation through the joists.

2 in. matched flooring, two layers of insulating paper, 1 in. matched sheathing, 4 in. by 4 in. sleepers 16 in. apart from centres, spaces between filled in with silicate cotton, double 1 in. matched sheathing

with twelve layers of paper between, and 4 in. by 4 in. sleepers 16 in. apart from centres embedded in 12 in. of dry underfilling.

Ground, concrete, layer of asphalt, 1-in. tongued and grooved match-boarding well tarred, two layers of stout brown paper, 1-in. tongued and grooved match-boarding, floor joists 3 in. by 11 in. spaced 21 in. apart, binder joists 11 in. by 4 in., bearing edges of floor joists protected by strips of hair-felt $\frac{1}{4}$ in. thick and spaces between joists filled in with flake charcoal, and $1\frac{1}{4}$ -in. tongued and grooved flooring boards.

The floors of the cold storage chambers built at the St Katherine Dock, London, were constructed as follows:—On the concrete floor of the vault, as it stood originally, a covering of rough boards $1\frac{1}{4}$ in. in thickness were laid longitudinally. On this layer of boards were then placed transversely bearers formed of joists $4\frac{1}{2}$ in. in depth by 3 in. in width, and spaced 21 in. apart. These bearers supported the floors of the storage chamber, which consisted of $2\frac{1}{2}$ -in. battens tongued and grooved. The $4\frac{1}{2}$ -in. wide space or clearance between this floor and the layer or covering of rough boards upon the lower concrete floor was filled with well-dried wood charcoal.

FLOORING FOR ICE HOUSES.

Floor to incline 3 in. towards central drain, and cross channelled fillets or scantlings on $1\frac{1}{4}$ in. flooring, 2 in. cement, 6 in. concrete, ground.

1-in. tongued and grooved match-boarding, three layers of paper, 1-in. tongued and grooved match-boarding (to incline 3 in. towards central drain) on fillets or scantlings, air spaces between, 1-in. tongued and grooved match-boarding, three layers of paper, 1-in. tongued and grooved match-boarding, 2 in. by 9 in. joists, spaces between filled with 4 in. silicate of cotton or slag-wool kept in position by $\frac{3}{4}$ -in. boards secured by cleats to joists.

CEILINGS FOR COLD STORES AND ICE HOUSES.

1-in. tongued and grooved match-boarding, three layers of insulating paper, 1-in. tongued and grooved match-boarding, 2 in. air spaces between strips or fillets, 1-in. tongued and grooved boarding, three layers of insulating paper, 1-in. tongued and grooved boarding, joists, spaces between filled with silicate cotton or cork, 1-in. tongued and grooved match-boarding, three layers of insulating paper, and 1-in. tongued and grooved match-boarding.

Insulated flooring, joists, $\frac{7}{8}$ -in. tongued and grooved match-boarding, two layers of insulating paper, $\frac{7}{8}$ -in. tongued and grooved match-boarding, 2 in. spaces between strips or fillets filled in with silicate cotton or cork, $\frac{7}{8}$ -in. tongued and grooved match-boarding, three layers of insulating paper, and $\frac{7}{8}$ -in. tongued and grooved match-boarding.

1-in. tongued and grooved boarding, two thicknesses of brown paper, 1-in. tongued and grooved boarding, joists with spaces between packed with silicate cotton, 1-in. tongued and grooved boarding, Willesden and brown paper, 1-in. tongued and grooved boarding.

Concrete floor, 3 in. book tiles, 6 in. dry underfilling, double space hollow tile arches and layer of cement plaster.

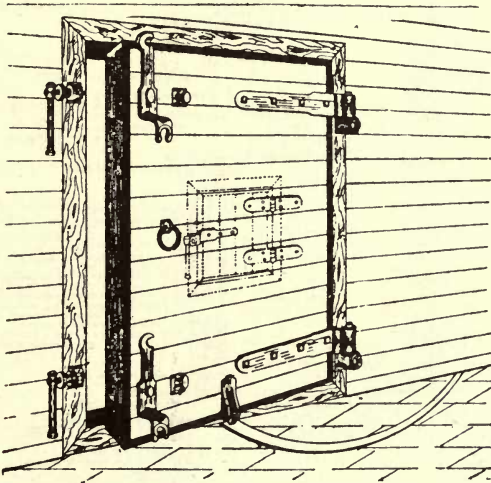

Fig. 225.—Door for Cold Store, with Taylor's Patent Fittings.

Double 1 in. floor with two layers of insulating paper between, 2 in. by 2 in. strips or fillets 16 in. apart from centres, spaces filled in with silicate cotton, two layers of insulating paper, 1-in. tongued and grooved match-boarding, 2 in. by 2 in. strips 16 in. apart, spaces filled in with silicate cotton, two layers of insulating paper, 1-in. tongued and grooved match-boarding, joists and double 1-in. flooring with two layers of insulating paper between.

DOOR INSULATION.

A weak point in most cold storage rooms is the door; these are usually constructed on the wedge principle, and several simple forms

are shown in the illustrations on this and succeeding pages. Even when properly designed and carefully made from the best, well-

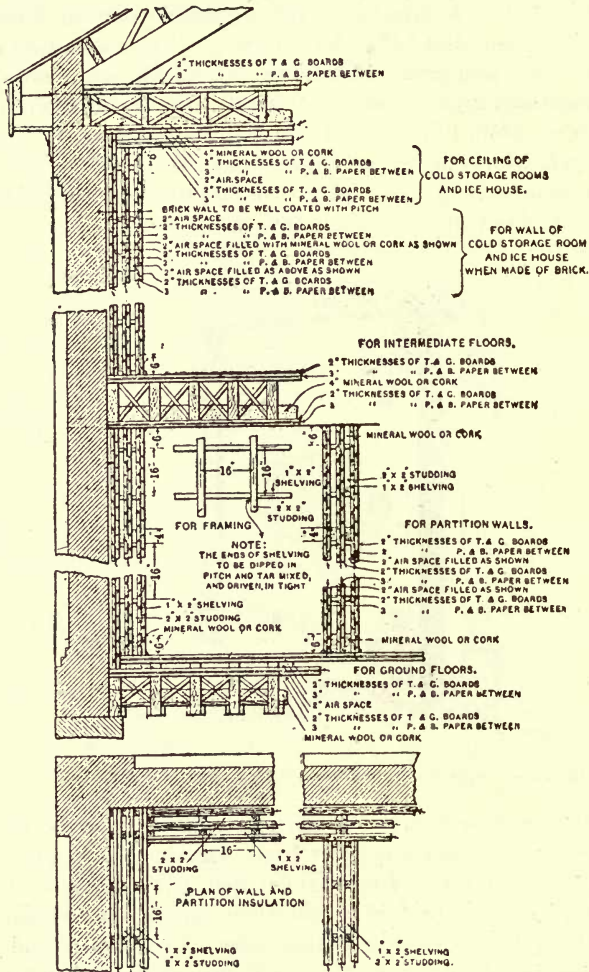

Figs. 226 and 227.—Frick Company Method of Insulating a Cold Store. Vertical and Horizontal Sections.

seasoned timber, the doors of cold storage rooms are very apt to give trouble on account of the extreme temperatures to which they are

subjected and from the absorption of moisture from the air. As there can be no doubt that considerable loss is experienced through badly-made and poorly-fitting doors, too much care cannot be expended in securing the best possible workmanship and efficient and easily manipulated fittings. Fig. 225 shows a type of door fitted with Taylor's patent door-fittings, of which Mr John Straiton, Liverpool, is the sole maker. A door much used in America is Stevens' patent, which is made up of five thicknesses of insulated and waterproofed paper, $\frac{1}{2}$ in. prepared mineral or slag wool, three air spaces, and four thicknesses of wood. Amongst the advantages claimed for this type of door is that it will not frost through with zero temperature. A canvas cushion on the bottom prevents the cold air from escaping at that point. The door will not stick. It closes quite tight on the hinge edge. The fastening is of a special pattern and is for both edges of the door. It is claimed to shut as tight as a cross-bar would if it were wedged up, and can be opened either from the exterior or interior. A special form of door, designed by the author for use in hotels, or elsewhere, where the cold storage room or chamber has to be frequently entered, has been described in a previous chapter. Other insulations for doors are:—

1-in. tongued and grooved match-boarding, three layers of insulating paper, 1-in. tongued and grooved match-boarding, 2 in. by 1 in. fillets or strips with spaces between filled in with silicate cotton or cork, 1-in. tongued and grooved match-boarding, three layers of insulating paper, 1-in. tongued and grooved match-boarding, 2 in. by 1 in. fillets or strips, spaces between filled in with silicate cotton or cork, 1-in. tongued and grooved match-boarding, three layers of insulating paper, and 1-in. tongued and grooved match-boarding.

1-in. tongued and grooved match-boarding, two layers of insulating paper, 1-in. tongued and grooved match-boarding, 12 in. space filled in with silicate cotton, 1-in. tongued and grooved match-boarding, two layers of insulating paper, and 1-in. tongued and grooved match-boarding.

WINDOW INSULATION.

Windows are better dispensed with in cold stores and artificial light resorted to; where present, three sashes spaced a few inches apart and glazed at both sides should be used.

TANK INSULATION.

Tank sides: 4 in. air space between studding, 1-in. tongued and grooved match-boarding, three layers of insulating paper, 1-in. tongued

and grooved match-boarding, 4 in. space filled with cork, 1-in. tongued and grooved match-boarding, three layers of insulating paper, 1-in. tongued and grooved match-boarding, 2 in. air space, 1-in. tongued and grooved match-boarding, three layers of insulating paper, and 1-in. tongued and grooved match-boarding. Bottom, 1 in. space between strips, fillets or studding, well tarred before tank is placed in position, 1-in. tongued and grooved match-boarding, three layers of insulating

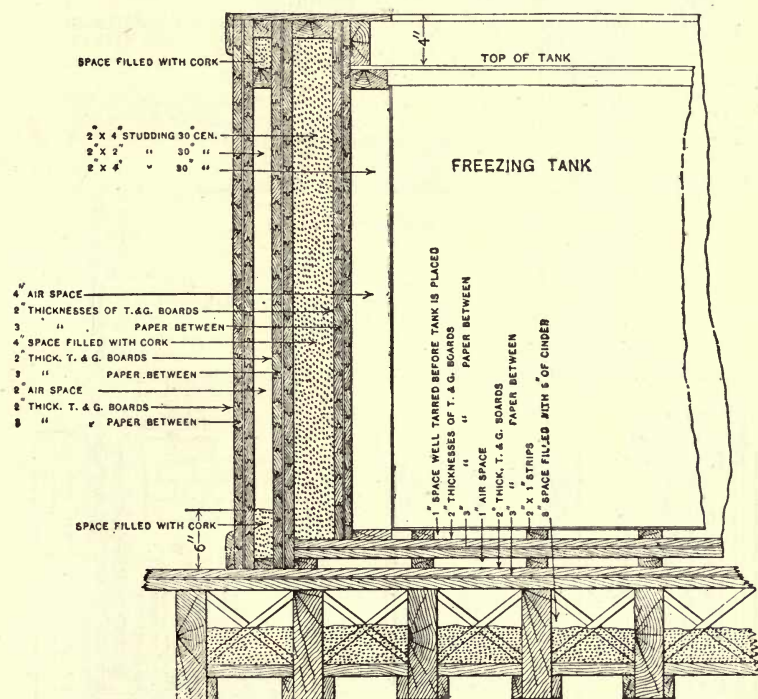
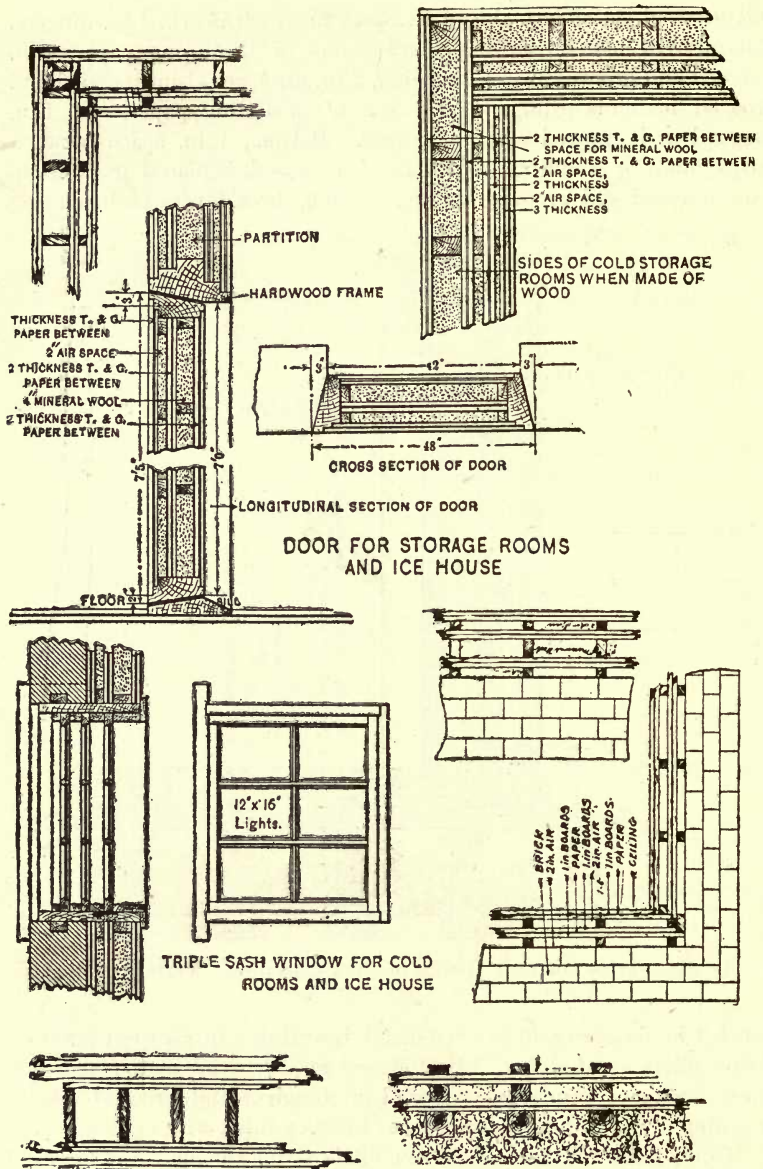

Fig. 236.—Frick Company Method of Tank Insulation. Vertical Section.

paper, 1-in. tongued and grooved match-boarding, 1 in. air space between strips, fillets or studding, 1-in. tongued and grooved match-boarding, three layers of insulating paper, 1-in. tongued and grooved match-boarding, 2 in. by 9 in. joists, spaces between filled with cinders.

Tank, 2 in. air space between fillets, $\frac{7}{8}$ -in. tongued and grooved match-boarding, two layers of insulating paper, $\frac{7}{8}$ -in. tongued and grooved match-boarding, 4 in. silicate cotton or slag-wool, $\frac{7}{8}$ -in. tongued



Figs. 237 to 246.—Barber Manufacturing Co. Methods of Wall, Floor, Ceiling, and Tank Insulation.

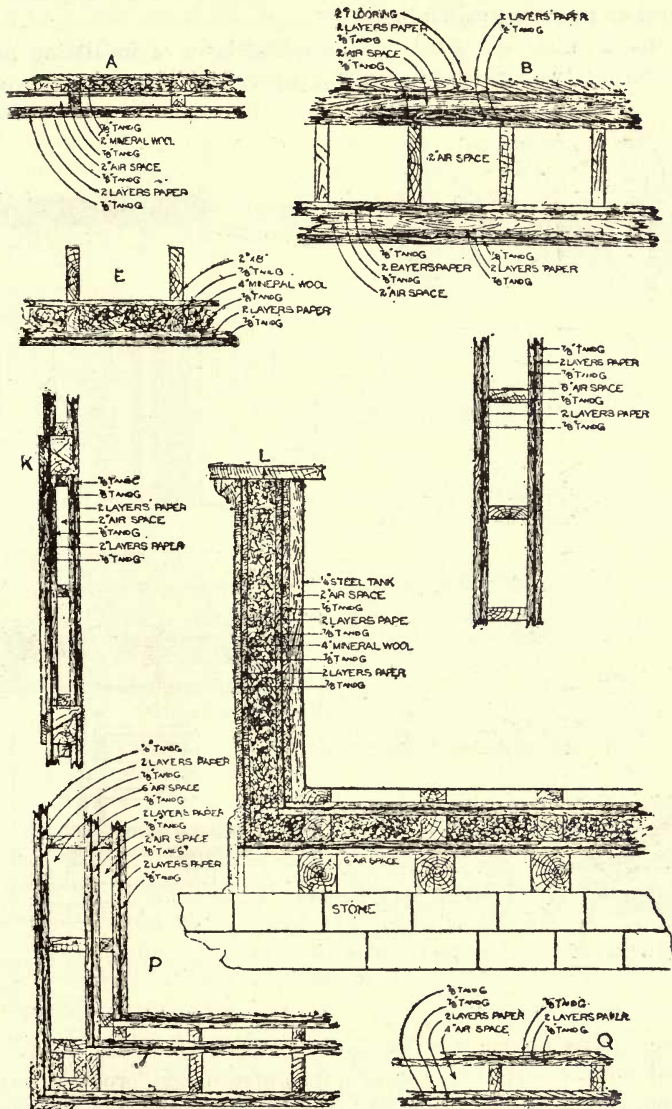

Figs. 247 to 254.—Triumph Ice Machine Co. Methods of Wall, Floor, Ceiling, and Tank Insulation.

METHODS OF INSULATION USED IN THE UNITED STATES.

In Figs. 226 to 265 are depicted various plans for insulation which have been successfully used in the United States. Figs. 226 and 227 illustrate a method of insulating a cold store recommended by the Frick Company; Figs. 228 to 235, various methods of wall, floor, ceiling, partition, door, and window insulation, and Fig. 236 a method of insulating a tank recommended by the same company. Figs. 237 to 245 give a number of methods of wall, floor, ceiling, door, window, and tank insulation used by the Barber Manufacturing Co., and Figs. 246 to 254 and 255 to 265 show at A, K, P, Q, G, H, M, N, O, R, and T, various wall insulations; at E a ceiling insulation; at B, C, D, V, U, and S, floor insulations; and at L a tank insulation according to the practice approved by the Triumph Ice Machine Co. The explanatory matter on the drawings sufficiently clearly indicates the construction of the above.

REFRIGERATED RAILWAY VANS.

An important type of portable refrigerator is that adapted to meet the requirements of railway vans, trucks, cars, or waggons, which it is desirable to maintain at a low temperature for considerable periods, but which, for obvious reasons, it is undesirable, in doing so, to encumber with machinery, to increase in weight to any considerable extent, or to render in any way necessary the employment of special labour to take charge of same.

The frozen meat, as a rule, arrives in good condition on board the vessels, and deterioration in quality usually takes place during its transference to the cold stores on land, and again during the subsequent delivery thereof to the retailer, when the meat is exposed to temperatures frequently much higher than what is required to preserve it in good condition. The great desideratum for this purpose is a plan which will avoid the necessity of carrying the source of refrigeration upon the conveyance itself, and this the Pulsometer Engineering Co., Ltd., claim to have successfully accomplished in their system of refrigeration for railway trucks or cars, and other portable chambers, and they state that they are willing to guarantee to maintain below the freezing point properly fitted portable chambers of all kinds, for ample time for transit between Penzance and Aberdeen.

The method of refrigeration primarily employed in vans and railway trucks, was to effect the production of cold with mixtures of ice and salt. The great objection to this arrangement is the large increment of

weight, and the nuisance and damage caused by the moisture due to the melting ice.

As early as the year 1867 a refrigerator car was constructed in the United States having a refrigerating chamber surrounded by an air space. A fan or blower was provided, driven off one of the car axles, and air was forced by this blower through a compartment containing ice into the refrigerating chamber. The water resulting from the liquefaction of the ice in the compartment, which had a capacity of about 2 tons, was drawn off through a suitable trap. In some instances the ice was replaced by a refrigerating mixture passing through a suitable pipe in the ice box or chamber. The air was drawn in by the fan during

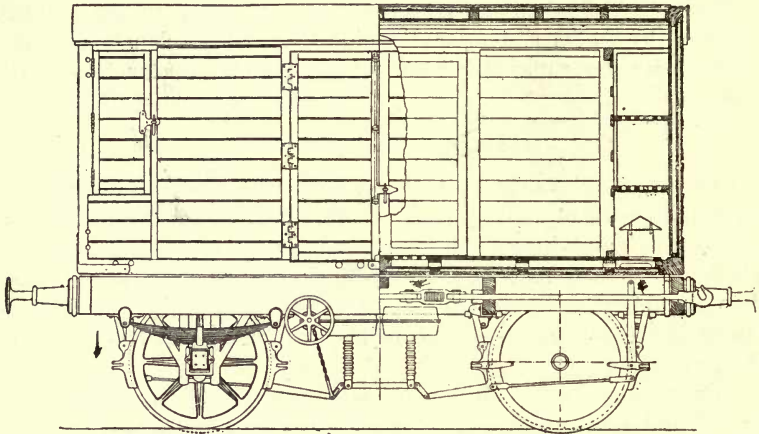

Fig. 266.—Refrigerator Van or Waggon, Great Southern and Western Railway, Ireland. Sectional Side Elevation.

the forward motion of the car, and after being passed through the ice chamber was delivered at the top of the refrigerating chamber. A car of this description is said to have successfully transported meat slaughtered in Illinois to New York, during the hottest part of the summer, no perceptible deterioration in quality having occurred during the ten days' journey.

Another refrigerator car of somewhat similar construction, having the external appearance of an ordinary freight car, has an ice box at each extremity wherein the ice is placed upon gratings so arranged that a current of cold air circulates continually through a flue situated near the top of the chamber, over the surface of the ice, down to the floor,

and then up over the surface of the ice, down to the floor, and then up again amongst the meat. The air circulation is maintained by a fan operated in a like manner to that above mentioned. The car was also built double, with inside double doors, filled in with charcoal, and the temperature of the meat was easily kept at about 40° Fahr. even in the hottest weather.

As has been already mentioned, Godell uses lampblack, or a mixture of lampblack and mica scales, as non-conducting material for use in refrigerator cars.

In another arrangement, also used in America, the car is cooled by means of some suitable volatile liquid, which is allowed to vaporise

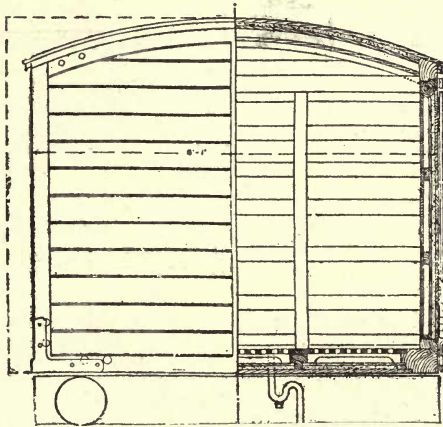

Fig. 267.—Refrigerator Van or Waggon, Great Southern and Western Railway, Ireland. End Elevation partly in Section.

slowly through a system of pipes from one reservoir into another, thus reducing the temperature of the chamber. An objection to this arrangement is the danger of leakage of the volatile liquid taking place into the refrigerating chamber.

Fig. 266 is a side elevation partly in section, Fig. 267 is an end elevation partly in section, and Fig. 268 is a sectional plan showing a refrigerator van or waggon built for the Great Southern and Western Railway of Ireland. These illustrations, which are reproductions on a reduced scale of cuts that appeared in *Ice and Cold Storage*, are self explanatory.

A refrigerator van, car, or waggon, said to be in use upon the

Illinois Central Railway, U.S., and which has been designed and patented by Mr H. F. Stanley, the foreman of the car department at New Orleans, Louisiana, is shown in Figs. 269 and 270 in sectional side elevation and in plan, and, according to the patent specification, consists essentially of the following features:—The car is provided with three floors, viz., a central or main floor A, which slopes in a downward direction from the sides of the van towards a central gutter, which runs through its entire length, and serves as a drain to carry off all internal drippings; a lower or sub-floor B, lined with paper-felt; and lastly a false, or deck floor C, formed of lattice work, and arranged in sections divided on the centre line of the car, each section being hinged or jointed to the sides of the latter, to admit of its being raised or

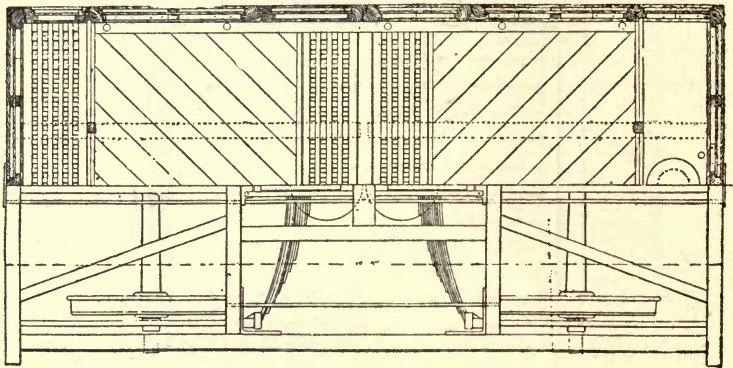

Fig. 268.—Refrigerator Van or Waggon, Great Southern and Western Railway, Ireland. Sectional Plan.

folded up, and thus allowing of access to the central or main floor and gutter for cleansing purposes. Ventilating doors D are provided at each end of the car, through which a current of air can be admitted which will circulate between the main floor and the latticed upper floor. E are hatches fitted with ventilating hoods, and removable plugs, and auxiliary screens, which admit of filling the ice tanks F.

The ice tanks or boxes are formed by doors or swinging partitions, hinged or jointed to the roof of the car about 3 ft. from each end, so that they can be either fastened up out of the way, as shown at G, or let down until they hang vertically, and reach the floor, as shown at G¹, forming, when in the latter position, the ice compartment or chamber F. At a height of 1 ft. 6 in. above the upper or deck latticed floor C, in

this ice chamber or compartment *F*, is provided a deck or false floor *H*, which consists of a hinged grating, which can be brought down into the position shown in Fig. 269 or can be folded back against the end of the car when not in use. The side door openings *I* are fitted with cross-bars *J*, which can be fixed firmly in position in such a manner as to be easily removable when desired. The van or waggon is supported upon bogie frames. A special feature in the arrangement is the very great facility with which the van can be converted from an

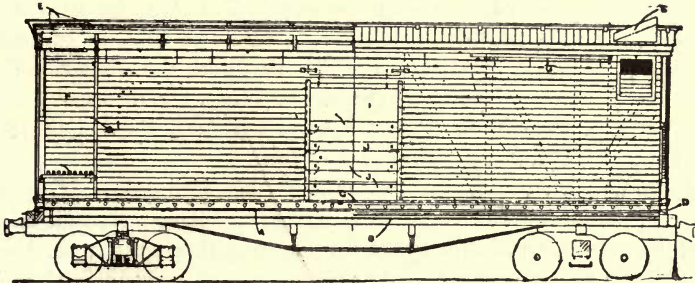

Fig. 269.—Refrigerator Car or Waggon, Illinois Central Railway, U.S.
Side Elevation partly in Section.

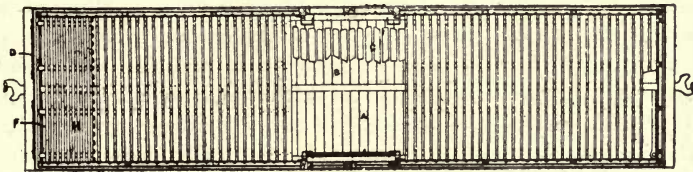

Fig. 270.—Refrigerator Car or Waggon, Illinois Central Railway, U.S.
Sectional Plan.

ordinary car or waggon into a refrigerator car, or *vice versa*, the time necessary for effecting the first-mentioned change, or for folding up out of the way the parts forming the ice chambers or compartments, being only about ten minutes. The car is, therefore, available for use as an ordinary freight car or waggon, or as a refrigerator car or van. The principal dimensions of this van or car are as follow:—Length of frame, 37 ft.; width of frame, 9 ft. Outside length of car body, 36 ft.; width of car body, 9 ft. Inside length of car, 35 ft.; width of car, 7 ft., from wall to wall, without ice chambers or compart-

ments. Height from upper or deck floor to ceiling plate, 8 ft. Clear space in car when ice chambers or tanks are in position, 29 ft.; width of ice chambers or tanks, 3 ft. each; length of do., 7 ft.; capacity of do., 108 cub. ft. The false upper or deck flooring is formed of 2 in. by 4 in. battens, and the central or main flooring of $1\frac{1}{4}$ in. by 5 in. battens. The lower or sub-floor has a $\frac{3}{8}$ -in. lining. The space or clearance for the circulation of air between the upper or deck floor and the central or main floor is 4 in. The width of the gutter in the central or main floor is 4 in. The doors or swinging partitions for forming the ice chambers or compartments are constructed of 2 in. by $2\frac{1}{2}$ battens. The width of the side door openings is 5 ft. The timbers supporting the bogie trucks or carriages are $8\frac{1}{2}$ in., and the centres of the latter are 5 ft. from the end of the car or van. The distance between the centres of the wheels in the trucks is 5 ft., and the height of the top of the truck from the wheel base is 29 in.

John Lobrist, of Hanford, California, has designed a refrigerator car, comprising vertical ice tanks or chambers placed at each end, to which chambers access can be had for charging through hatches having hermetically closing doors. These chambers are surrounded by open-work walls with an annular air passage arranged exteriorly, and a second open or net-work wall located outside the air chamber. In a space or clearance situated exteriorly to the air chamber, and between the latter and an outer closed casing, is placed a layer or filling of salt. A lining extends right across the top of the car and from end to end thereof, so as to form a passage between it and the roof; and a central opening which communicates with the body of the car, and openings at the extremities which give access to air passages surrounding the ice chamber, are also provided. Centrally along the floor of the car is a passage, around and over which passage the boxes are packed, openings being provided between the opposite ends of the passage in question and the lower ends of the refrigerating air chambers at the ends of the car. Fans mounted in these openings cause a circulation of air to take place through the refrigerating chamber and the body of the car, the air returning through the air passages adjacent to the roof of the latter. The air-circulating mechanism is driven by an arrangement of gearing from the axles of the car, which operates the pistons or plungers of compressor cylinders connected with compressed air receivers or reservoirs. The air thus compressed is employed to drive motor wheels, which in turn drive the fans. A compressor cylinder fixed to a frame to which the crankshaft working the compressor pistons or plungers is journalled, and which

cylinder is connected through a suitable pipe with the compressed air receiver or reservoir, admits, by allowing air under pressure to enter the cylinder, of so acting upon its piston or plunger as to raise the journal frame and crankshaft, thereby disengaging the driving gear and stopping the action of the pumps, when desired.

Refrigerator cars have also been designed, fitted with refrigerating machinery. One type of car patented by M. E. Schmidt and T. J. Ryan, of York, U.S., has an installation of refrigerating machinery on the ammonia compression system. A dynamo, driven from one of the axles, supplies current to an electro-motor and to a storage battery. The compressor is in this manner driven by electric power, and by means of the storage battery can be continued in operation for a certain time whilst the car is at rest.

An attempt has been recently made in the United States, by the Standard Butter Co., Oswego, New York, to refrigerate or cool a car or van for the transport of butter, by the application of liquid air. The refrigerator car used was an ordinary one, and the expense of adapting it for the test was only about £5.

The cooling apparatus is extremely simple, consisting merely of about 200 feet of 2-in. galvanised iron pipe coiled on the ceiling, and running lengthways from end to end of the car. This pipe is connected to a small cylindrical galvanised iron tank some 4 ft. high, and 2 ft. in diameter, which is fixed in one corner of the car, and contains the liquid air. From this iron tank the liquid air is forced, at a pressure of about 4 lbs. to the square inch, to the coil of pipe overhead, an arrangement which, it is claimed, admits of the temperature of the van being raised or lowered at the will of the operator.

According to reports of the test, within an hour from the first application of liquid air to the van, the temperature was reduced to 15° below zero, and held at that point for three hours. The tank used contained sufficient liquid air to keep the temperature down for twenty-four hours without having to be recharged. The air in the van was found to be perfectly pure, there being no moisture anywhere to be seen, very little frost on the pipes, and no drip whatever. After the test the floor was clean and dry, and the truck itself presented in every way a much more pleasing look than when ice is used, with its waste and continual drip.

CHAPTER XIV

REFRIGERATION AND COLD STORAGE (*continued*)

Hoisting and Conveying Machinery.

A NUMBER of cranes, and hoists and lifts, are required in a cold store of any size for handling the carcasses. The first-mentioned do not differ materially from those employed in factories, warehouses, &c., the second, however, are usually of special construction. The motive power may be either steam, gas, compressed air, water under pressure, or electricity. The advantages of hydraulic power are: Perfect security in handling the load when raising or lowering it, and being able to stop the load in any position. Great simplicity of construction. Facility of operating enabling skilled operators to be dispensed with. Relatively small cost of construction and operation. Noiselessness in action. The provision of water under pressure on the premises in case of fire. All the above advantages, except the last, are also applicable to the use of electricity, and the latter power has the further advantage of being unaffected by cold. Space does not admit of more than touching briefly upon this portion of the subject, and of giving illustrations and short descriptions of two or three carcass hoists by way of example. Short descriptions of cranes, hoists, and conveyors for handling ice will be found in the chapter on "Ice-making."

Figs. 271 to 276 show various views of an automatic electric beef hoist, designed by Messrs J. G. Childs & Co., Ltd., London. The construction of the hoist will be readily understood from the drawing. It consists of any suitable number of cradles, in this instance ten, running in vertical guides, and suspended from two endless chains. Two hinged platforms are provided at each floor, the one for loading and the other for unloading, and these platforms are turned back out of the way at all the floors not in use. In order to load the hoist, the loading platform on any of the floors is turned into position to receive the carcasses, which are then placed one by one upon this platform, the next cradle in rising lifting the quarter of beef and carrying it up over the top of the lift and down on the other side, finally depositing it

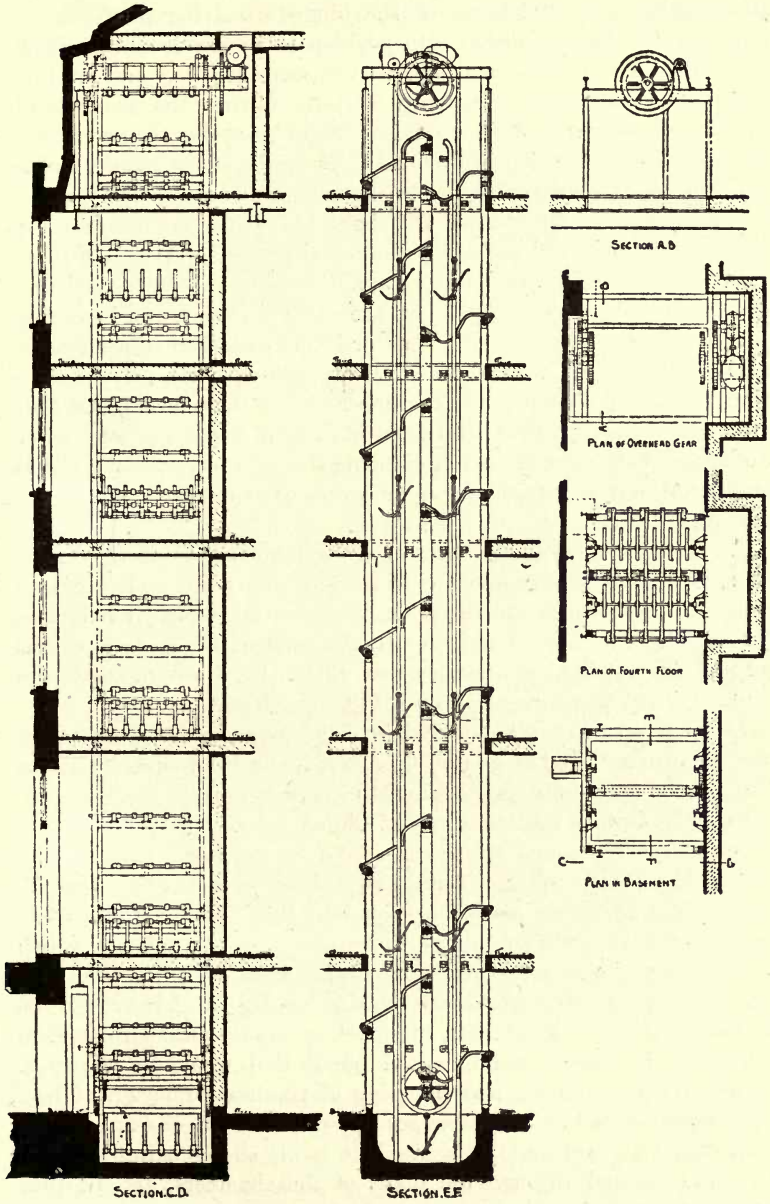

Figs. 271 to 276.—Childs' Patent Automatic Electrically-driven Beef Hoist or Elevator.

automatically upon whichever of the hinged receiving platforms or forks that has been adjusted into position to receive it and lift it off the cradle. The cradles are kept in the same position and are prevented from swinging or moving laterally during the rising and descending movement of their vertical travel by means of the vertical arms shown, one of which is provided at each side of the cradle, and is fitted at each extremity with rollers engaging between vertical guides. The upper ends of these arms are connected to the endless carrying chains of the hoist, and the cradle is secured to the lower ends of these arms or levers. When each of the cradles reaches the upper or lower sprocket or chain wheels supporting the endless chains, and is passing round them, the rollers on its arms or levers pass clear of the guides, and it will be seen that the cradles are consequently permitted to swing free from their pivot at the upper end of these levers, and thus to retain a vertical position whilst passing round the upper and lower sprocket or chain wheels. After clearing the sprocket or chain wheels the rollers on the vertical arms or levers once more engage in the vertical guides.

The beef hoist motor (which is a Westinghouse $3\frac{1}{2}$ H.P. electric motor) is located at the upper extremity of the hoist, and is geared through a worm-wheel, the thrust of which is taken up by ball-bearings, which have been found greatly to reduce the friction of the gearing. The switching arrangements enable the above motor to run on either a 530 volt current, or on a 400 volt current.

The motor can only be started from the weigh-bridge room, which latter is situated on the ground floor, but it can be stopped by means of any of the press buttons placed on the various floors.

Fig. 277 shows a portion of one of Childs' patent hoists or elevators erected at the Campania Sansinena's Cold Stores, Long Lane, Smithfield, London, with a quarter of beef in position on one of the cradles.

This beef hoist has a capacity equal to the delivery of about 300 quarters of beef per hour on the uppermost floor of the store, which in the example shown is four storeys in height, at a cost of about $2\frac{1}{2}$ d. per 100 quarters. A considerable saving of labour can be effected by the use of this lift, inasmuch as by its automatic system of delivery it enables a number of hands that would be otherwise required for the removal and handling of the heavy quarters of beef to be dispensed with. The carcasses are delivered in close proximity to the chambers, and could, if desired, be easily slid on suitable chutes or inclines to and through the doors of the chambers, and be thus passed entirely automatically into the latter.

The elevators for the Southampton Cold Storage Co. have likewise been designed and are being supplied by Messrs Childs. These

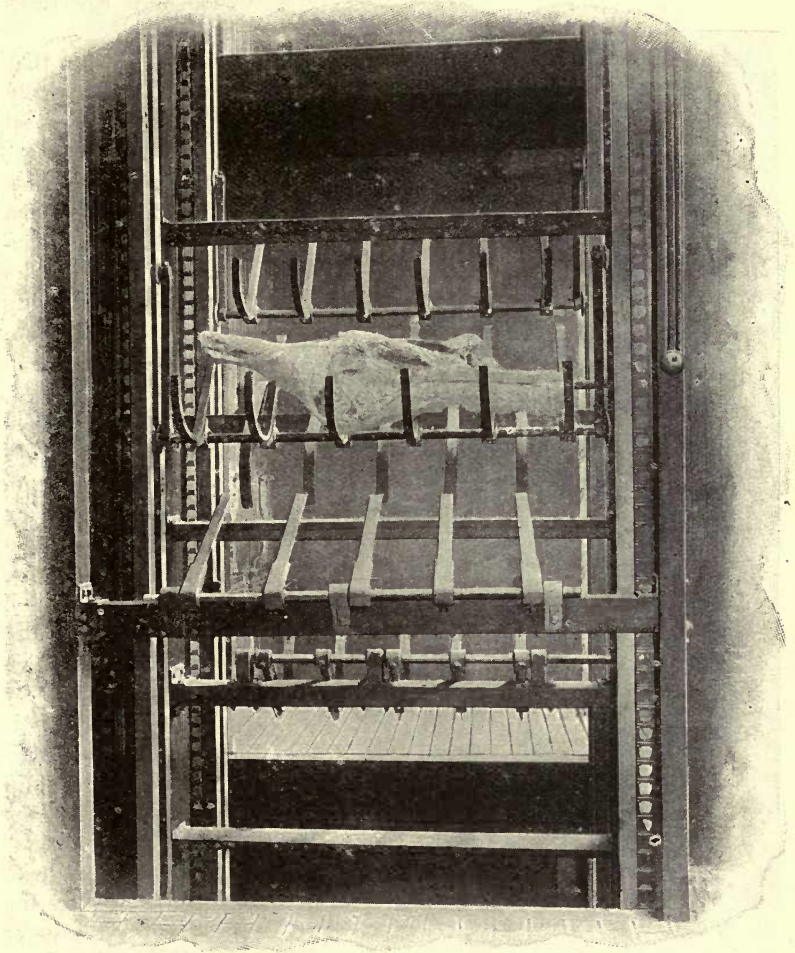

Fig. 277.—Childs' Patent Automatic Electrically-driven Beef Hoist.
View showing a Quarter of Beef in position on one of the cradles.

elevators are each intended to take the produce from the ship's side, raise it about 50 ft. vertically, and then convey it for about another

50 ft. horizontally, finally automatically depositing it at the desired spot. Each elevator will be capable of dealing with about 1,800 carcasses of mutton per hour, or about 600 quarters of beef, barrels, or

Continental egg-cases per hour.

It will be seen that these lifts are really combined elevators and conveyors.

Fig. 278 is a view showing a portion of a mutton hoist, also constructed by Messrs Childs, and working at the Campania San-sinena's Cold Store in London. This hoist, it will be seen, consists of two vertically arranged parallel endless chains, carrying at intervals sheet-iron trough-shaped cradles or carriages, into which the carcasses are placed, and from which they are removed by hand. The hoist is operated by an electric motor located, in this instance, at the bottom.

This mutton hoist is capable of delivering about 700 carcasses of frozen sheep per hour at the top or fourth floor of the store at a

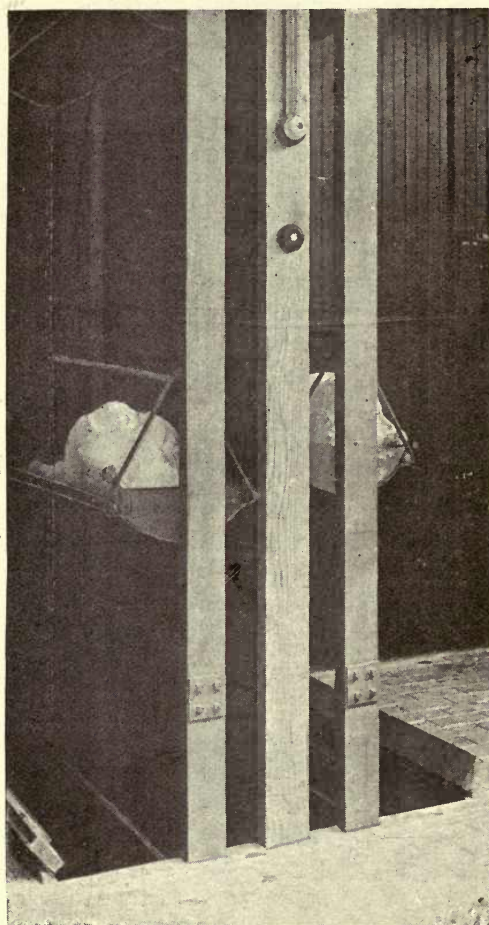

Fig. 278.—Mutton Hoist in London Cold Store.

cost of about three-farthings per hundred carcasses.

Figs. 279 and 280 are two views showing an external carcass hoist or lift erected at Nelson's Cold Storage Wharf, Lambeth, by Messrs

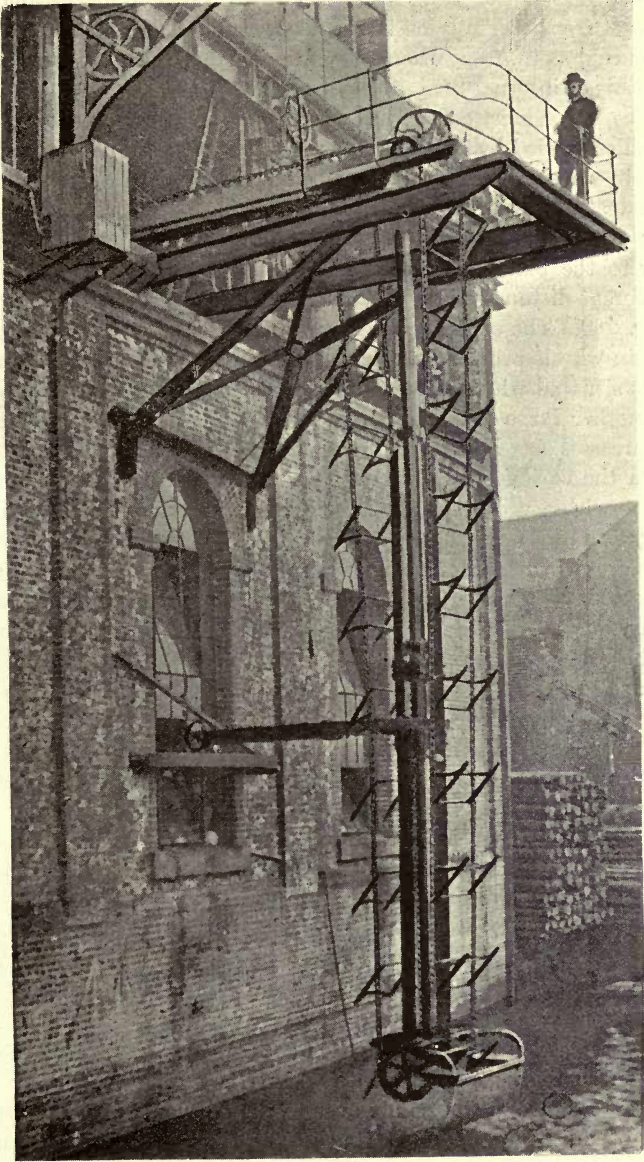

Fig. 279.—External Carcass Hoist at Nelson's Cold Storage Wharf, London. At Rest.

R. Waygood & Co., Ltd., Falmouth Road, London, for raising frozen carcasses from barges lying in the river, and delivering same to the top of the cold store, from where they are distributed to the various floors by means of internal lifts.

This lift or hoist consists, as will be seen from the cuts, of a number of cradles carried by two parallel endless chains mounted upon sprocket or chain wheels, those at one end being carried upon a long arm or jib pivoted at its upper extremity to a suitable platform, and capable of being swung or moved by hydraulic power into various angles relatively to the platform, so as to enable the carcasses from barges lying at different distances from the wall of the store to be raised, as shown in Fig. 280. The endless chains carrying the cradles pass over sprocket or chain wheels provided upon the platform to other sprocket or chain wheels situated within the building at the point of discharge.

Another large cold store in London, with river frontage, in which the carcasses are also taken in from the top, and conveyed down by lifts to the various floors below, has at the upper part of the building a crane with a very long jib, enabling barges lying at a considerable distance from the wharf to be reached. The carcasses are raised from the barges by means of this crane in a sailcloth, a number at a time, and are delivered to a suitable platform at the top of the store, from whence they can be delivered to the vertical internal lifts, and conveyed thereby to the various floors.

In some stores lifts capable of carrying both passengers and meat in trucks are employed, and also lifts of the ordinary direct-acting type, with arrangements for tipping automatically at the end of the stroke so as to effect the discharge of the loads on to a receiving table, the latter being in use at the Victoria Dock, London. At the West India Dock there are four hydraulic lifts, which are supported on one side only in the form of a bracket, and the greater part of the work of transporting the frozen carcasses is carried out by gravitation.

In the West Smithfield store, besides two lifts by Messrs R. Waygood & Co., capable of carrying either passengers or goods, there are two other lifts designed by Mr H. F. Donaldson, M.I.C.E.,* which are so arranged that carcasses of meat are loaded at the receiving platform, where the attendant in charge is already informed by the tallyman as to the chamber into which the various loads are to go. By levers he throws the points over to the floor on which the carcasses have to be discharged, and starts the lift, after which he need only let

* *Proceedings of the Institution of Civil Engineers*, vol. cxxix., Session 1896-7, Part iii.

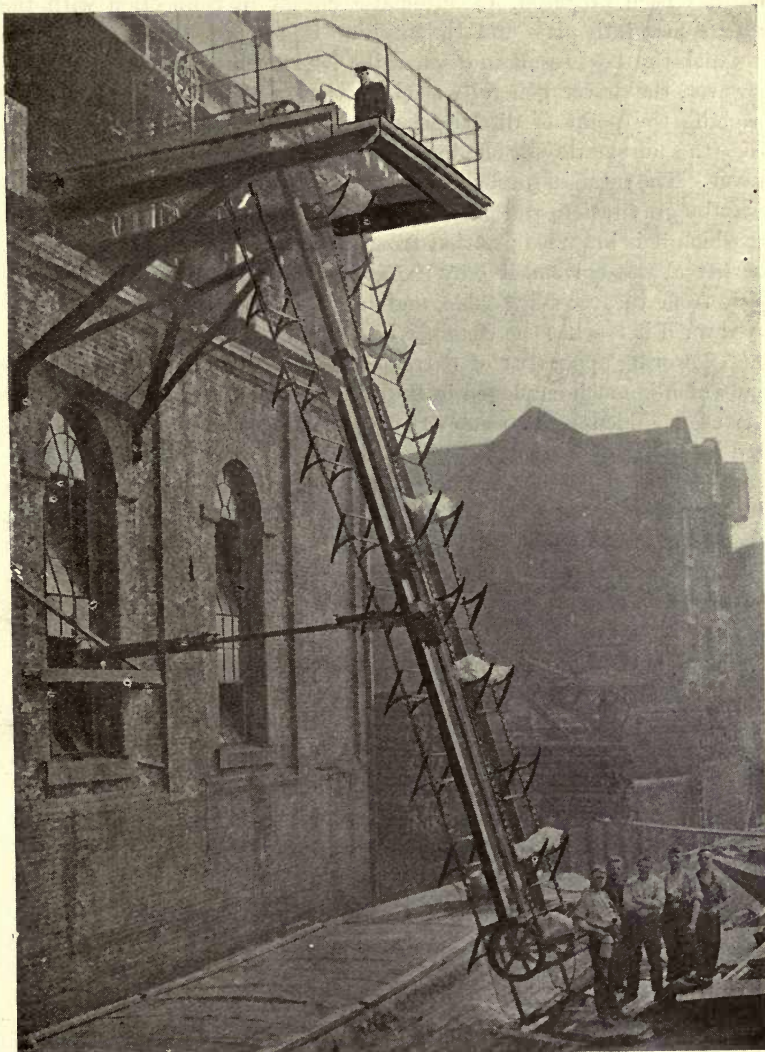

Fig. 280.—External Carcass Hoist at Nelson's Cold Storage Wharf, London. At Work.

the lift run its course, as, when it reaches the point at which the turn-out has been prepared, an automatic cut-off in connection with the lever comes into play, and the machine is stopped at the exact place at which the best result in discharging is to be obtained. In practice, however, the driver generally slackens the speed of travel just before reaching the point of discharge, so as to avoid the jar which results from the automatic cut-off due to the high speed at which these lifts travel. The meat so discharged on to a table overhead naturally falls away by gravitation, and passes along chutes directly into the chamber for which it is intended; so that from the time the meat is placed upon the lift at the bottom, it only requires to be directed into its proper chute from the receiving-table, and has not, of necessity, to be again lifted until it reaches the chamber in which it has to be stored.

A lowering apparatus of extremely simple and ingenious construction which is much employed in the United States, consists essentially of a cage guided by two supporting angle irons, and somewhat more than balanced by a weighted piston, which latter is fitted with a steel air tube located at the rear. This air tube is perforated in order to admit of the air escaping therefrom when the piston rises during the lowering of the cage, and the perforations near the upper end or top of the tube are regulated in size and made smaller so as to cushion the air as the cage reaches the lower level. In operation, as soon as the cage is loaded it descends very rapidly, and is brought gradually to rest in the last two or three feet of its downward course. As soon as the cage reaches the bottom level it engages with a lever and is automatically upset or tilted so as to turn out its load on the lower platform, and directly it is relieved of its load the cage rises or ascends rapidly under the action of the loaded piston located in the air tube, the piston and cage being brought to rest by air cushioning at the bottom of the tube in a manner practically similar to that already mentioned. It will be seen that this lift or lowering apparatus operates entirely by gravity, and requires no motive power whatever.

This apparatus could be advantageously employed wherever the dimensions of a room or chamber are so limited as to render the use of an ordinary "run way" or "sliding way" inadvisable owing to necessitating too steep a gradient in the latter.

CHAPTER XV

REFRIGERATION AND COLD STORAGE (*continued*)

Proper Methods of Storing, and Temperatures for the Cold Storage of Various Articles—Specific Heat and Composition of Victuals—Meats and Fish—Butter—Cheese—Milk—Eggs—Fruits—Vegetables—Morgues or Mortuaries—Table of Temperatures for Cold Storage of Various Articles.

SPEAKING generally, cold storage rooms or chambers are maintained at a temperature of somewhere near 34° Fahr.; rooms or chambers for chilling at about 30° Fahr.; and freezing rooms or chambers at anything between 0° Fahr., or lower, and 10° Fahr.

The amount of refrigeration required to cool a given amount of food product through a given range in temperature is a practically fixed quantity for a given product, but varies widely with different products. The following particulars on this head are given by Mr F. C. Matthews in an article entitled "Cold Storage Duty," which appeared in a recent number of *Power*, New York:—

"When cooling is not to be carried below the freezing-point the amount of the refrigeration required, says the author, may be found by multiplying the specific heat of the product by the number of degrees through which it is to be cooled. If the product is also to be frozen, this amount of refrigeration must be increased by the amount of the latent heat of fusion, and if cooling is to be continued below the freezing-point, the refrigeration must be further increased by the specific heat of the product below 32° Fahr. multiplied by the number of degrees through which it is cooled below freezing-point. The specific and latent heat of a number of products commonly preserved in cold storage are given in the table.

"It is required, for example, to cool 10,000 lbs. of freshly killed poultry through 68° Fahr. The specific heat as given in the table is .80°. The number of B.T.U. to be removed will be—

$$\cdot 80 \times 10,000 \times 68 = 544,000.$$

Dividing this result by 144 (number of B.T.U. per pound of refrigera-

382 REFRIGERATION AND COLD STORAGE.

tion), the amount of cooling duty is found to be 3777·7 lbs. If the poultry is frozen, the additional refrigeration required will be—

$$10,000 \times 105 = 1,050,000 \text{ B.T.U.}$$

or ($\div 144$) 7,292 lbs., and if additional cooling to zero degrees Fahrenheit is required, the additional cold necessary will be—

$$10,000 \times \cdot 42 \times 32 = 134,000 \text{ B.T.U.}$$

or 933·3 lbs. The total refrigeration duty required to cool the products through 68° Fahr., freeze it at 32° Fahr., and then chill it to zero degrees Fahrenheit, would be—

$$3777\cdot 7 + 7,292 + 933\cdot 3 = 12,003 \text{ lbs.}$$

or, dividing by 2,000 (pounds per ton), 6 tons.

“The table may be found convenient in estimating the amount of refrigeration required to chill beef, pork, and sausage through 54° Fahr., or from 104° to 40° Fahr.

“It may be noticed that ten 750-lb. fat beeves, and thirty-five 250-lb. hogs require one ton of refrigeration for the cooling of the meat alone. In estimating the cooling capacity of a medium for packing-house work, a ton of refrigeration is allowed for from five to seven beeves, weighing from 700 to 750 lbs., and for from fifteen to twenty-four hogs weighing 250 lbs. Still another rough rule sometimes employed is to allow a ton of refrigeration for from 3,000 to 4,000 lbs. of meat cooled. These larger figures are intended to give ample reserve capacity to provide for ordinary insulation and other losses encountered in packing-house practice.”

REFRIGERATION REQUIRED TO COOL MEATS.—*Matthews.*

| Products. | Poultry. | Beef Fat. | Beef Medium. | Beef Lean. | Pork Fat. | Sausage (15% Water). |
|--|----------|-----------|--------------|------------|-----------|----------------------|
| Specific heat - - - | 0·80 | 0·60 | 0·68 | 0·77 | 0·51 | 0·65 |
| B.T.U. to cool 1,000 lbs. 1° Fahr. - - - | 800 | 600 | 680 | 770 | 510 | 650 |
| B.T.U. to cool 1,000 lbs. 64° Fahr. - - - | 51,200 | 38,400 | 43,520 | 49,280 | 32,640 | 41,600 |
| Pounds refrigeration per 1,000 lbs. (64° Fahr.) - | 355·55 | 266·66 | 302·22 | 333·66 | 226·66 | 228·88 |
| Pounds of meat cooled, 64° per ton refrigeration - | 5,625 | 7,500 | 6,615 | 5,844 | 8,765 | 6,923 |
| Average weight carcass, lbs. ... | ... | 750 | 750 | 750 | 250 | ... |
| Carcasses cooled per ton - | ... | 10 | 6·82 | 7·78 | 35·3 | ... |

SPECIFIC HEAT AND COMPOSITION OF VICTUALS—*Cooper and Matthews.*

| Product. | Water. | Solids. | Specific Heat above Freezing Calc. | Specific Heat below Freezing Calc. | Latent Heat of Freezing Calc. |
|---------------|--------|---------|------------------------------------|------------------------------------|-------------------------------|
| Lean beef - - | 72·00 | 28·00 | 0·77 | 0·41 | 102 |
| Fat beef - - | 51·00 | 49·00 | 0·60 | 0·34 | 72 |
| Veal - - - | 63·00 | 37·00 | 0·70 | 0·39 | 90 |
| Fat pork - - | 39·00 | 61·00 | 0·51 | 0·30 | 55 |
| Eggs - - - | 70·00 | 30·00 | 0·76 | 0·40 | 100 |
| Potatoes - - | 74·00 | 26·00 | 0·80 | 0·42 | 105 |
| Cabbages - - | 91·00 | 9·00 | 0·93 | 0·48 | 129 |
| Carrots - - | 83·00 | 17·00 | 0·87 | 0·45 | 118 |
| Cream - - - | 59·25 | 30·75 | 0·68 | 0·38 | 84 |
| Milk - - - | 87·50 | 12·50 | 0·90 | 0·47 | 124 |
| Oysters - - | 80·38 | 19·62 | 0·84 | 0·44 | 114 |
| White fish - | 78·00 | 22·00 | 0·82 | 0·43 | 111 |
| Eels - - - | 62·07 | 37·93 | 0·69 | 0·38 | 88 |
| Lobsters - - | 76·62 | 23·38 | 0·81 | 0·42 | 108 |
| Pigeons - - | 72·40 | 27·60 | 0·78 | 0·41 | ... |
| Poultry - - | 73·70 | 26·30 | 0·80 | 0·42 | ... |
| Butter - - - | ... | ... | 0·64 | 0·84 | ... |
| Mutton - - - | ... | ... | 0·67 | 0·81 | ... |

MEATS AND FISH.

The freezing and storing of meat has been already touched upon in the previous chapter. Fish is by no means an easy article to deal with, and it is maintained by many that the best method of preserving it is to pack with ice. Indeed, attempts to employ refrigeration on steam trawlers have not been signalled by remarkably good results, and the old plan of an ice room still holds the leading place. Some kinds of fish indeed will not stand low temperatures at all, and are spoiled if they are exposed to anything as low as 15°.

The following is a method of freezing fish, described by a successful firm in the United States:—"When the fish are unloaded from the boats they are first sorted and graded as to size and quality. These are placed in galvanised iron pans 22 in. long, 8 in. wide, and 2½ in. deep, covered with loosely-fitting lids, each pan containing about 12 lbs. The pans are then taken to the freezers. These are solidly built vaults, with heavy iron doors, resembling strong rooms, and filled with coils of pipes, so arranged as to form shelves. On these shelves the pans are placed, and as one feature of the fixtures is economy of space, not an inch is lost. The pans are kept here for twenty-four hours in a temperature at times as low as 16° below zero. Each vault or chamber

has a capacity of $2\frac{1}{2}$ tons, and there are sixteen of them, giving a total capacity of 40 tons, which is the amount of fish that can be frozen daily if required.

“On being taken out of the sharp freezers the pans are sent through a bath of cold water, and when the fish are removed they are frozen in a solid cake. These cakes are then taken to the cold storage warehouse, which is divided into chambers built in two storeys, almost the same as the sharp freezers. The cakes of fish, as hard as stone, are packed in tiers, and remain in good condition ready for sale. It is possible to preserve them for an indefinite time, but as a rule frozen fish are only kept for a season of from six to eight months. They are frozen in the spring and fall, when there is a surplus of fish, and sold generally in the winter, or in the close season, when fresh fish cannot be obtained.”

For shipment, says the same authority, fish may be packed in barrels after the following directions:—“Put in a shovelful of ice at the bottom of the barrel, and be always careful to see that auger holes are bored into the bottom of the barrels, to let the water leak out as fast as it is produced by the melting ice. After putting in a shovelful of fine ice, crushed by an ice mill, put in about 50 lbs. of fish; then another shovelful of ice on top of the fish, &c., until the barrel is full, always leaving space enough on the top of the barrel to hold about three shovelfuls of ice. By shovels, scoop shovels are meant.”

The following is said to be the usual method adopted in salmon freezing works on the Pacific Coast:—The choice steel head and oval chinook salmon are received in a large, airy room, where they are washed, thoroughly cleansed, and laid upon large trays, which are ranged in tiers one above the other. When a truck-load of these trays is filled it is wheeled into the freezing room, where it remains about thirty-six hours. The cars are then wheeled into the packing room. Here the fish are placed upon a large elevator or dipping machine, and submerged in a vat of cold water. They are then let stand for a few minutes, and a thick coating of ice is formed around each fish. The fish are then wrapped separately in paper and packed in boxes, which are put into refrigerator cars and shipped to the markets of the world.

Mr C. J. Tabor, in a paper read before the Cold Storage and Ice Association, gives the following particulars regarding the preservation of fish: “One of our large refrigerating companies, he says, has hit on the plan of covering fish with a thin layer of water and then freezing it. So to speak glazing the goods, and from samples I have seen this

works very well ; but let us consider what has happened : the whole body has first of all been cooled down to 40° Fahr. before the surface ice can form. I myself have often preserved white fish—cod, haddock, turbot, plaice, hake, &c.—by simply hanging them in a store at 28° Fahr. and leaving them till hard frozen, then transferring them to a chamber cooled down to 15° Fahr., they were delivered in Melbourne three months later in the pink of condition. Most of the pleuronectidæ bear refrigeration exceedingly well, but soles and smelts do not ; the former appear to be broken up by the process and will not skin properly. Smelts are so delicate that a natural frost often renders them unsaleable. Salmon bears the initial freezing very well, but if allowed to rise in temperature and be then refrozen it becomes unsightly and rank in flavour. Eels will not bear the refrigerating process, but become so rank as to be uneatable. The reason I would assign for this rancidity both in eels and in salmon is that in the natural order of things fresh salmon contains a deal of oil in the fat which constitutes the so-called curd, so appreciated in fresh salmon ; when it is cooled down to a low temperature the fat cells are burst, and permeating the tissue give it a rank flavour. The oil, moreover, finds its way to the surface and causes that yellow look so often seen in long stored salmon which has experienced anything in temperature ; on this oleaginous pabulum a peculiar form of mould is often found. Frozen salmon requires to be used as soon as thawed ; if exposed for any length of time the flesh goes into a soft mass and looks as bad as it tastes. Eels are nearly as delicate as smelts, and are spoiled for commercial purposes even if naturally frozen.”

BUTTER.

Butter can be preserved by either keeping it in a chamber at the ordinary cold storage temperature, or by freezing, the latter being said to give the best results as regards the retention of the flavour and other qualities of the butter. For lengthened storage it is recommended to freeze the butter rapidly at a temperature of from 5° to 10° Fahr., and afterwards to keep it at about 20° Fahr.

The thawing can be effected by simply removing it from the freezing chamber, and when selling it is desirable to allow the butter to stand for a short time in order to develop the flavour. See also chapter on “Refrigeration in Dairies,” pages 422 to 438.

CHEESE.

Cheese should not be placed in cold storage until it is getting on in ripening, so as to prevent unpleasant odours, and it should not be previously subjected to any high temperatures. Cheese is better not frozen, but in case the latter should occur, the thawing must be gradual, and it is advisable to consume it as soon as possible, as it will not keep long after this has occurred. If the atmosphere of the room is too dry the cheese will shrink and crack, and on the other hand, if damp, the cheese will become mouldy.

MILK.

Milk should only be kept in cold storage for limited periods. A method has, however, been proposed, according to Professor Siebel, for concentrating milk by the freezing process by which part of the water in the milk is converted into ice. The ice is allowed to form on the surface of the pans, which are placed in cold rooms, and the surface of the ice is broken frequently, to present a fresh surface for freezing.

The refrigeration and cold storage of milk will be found further dealt with in the chapter on "Refrigeration in Dairies," pages 422 to 438.

EGGS.

Eggs can be kept in cold storage for some months, but the difficulties to be overcome in order to ensure success are considerable.

The contents of eggs can be stored in bulk, to effect which the eggs are emptied into tin cans containing about 50 lbs. and stored at 30° Fahr. They will keep for any reasonable length of time, but must be used quickly after thawing.

In the United States, where much attention has been given to the cold storage of eggs and where the value of the eggs placed in cold storage annually is estimated at about \$20,000,000 (and it must be remembered that the prices there are low, and consequently this sum represents a very large quantity), many concerns met with financial disaster, and those which have succeeded have had to instal new systems and make expensive changes.

It is important that eggs for cold storage should be very carefully selected, and that every bad one should be picked out by candling. Considerable attention has been given in Belgium to the cold storage of

eggs, and at a large establishment (La Fermiere) in Brussels the following is the process carried out. On arrival the eggs are rapidly inspected by means of an egg-testing machine, which consists briefly of a frame fitted with an endless moving carrier worked by hand, and constructed of bobbins fitted closely together and lined with cloth, thus affording accurate hollows in which the eggs may be placed. Over the central portion of the frame is constructed a dark chamber or room through which the carrier moves, and beneath the carrier in this dark chamber is a powerful electric lamp by which the spots or dark colour of the bad eggs will be shown up. This apparatus admits of an exceedingly rapid inspection, a large-sized one installed at the works in question being capable of dealing with between four and five hundred eggs per minute. The eggs are fed on trays to the testing machine, and after testing are placed in cases of from three to five hundred, the smaller package being found to be the most convenient for handling. These cases are first taken to an outer egg store, where they are reduced to a temperature of about 33° Fahr. From there they are removed to the general store where they are kept at a temperature just below freezing. The cold rooms are provided with large air locks or lobbies.

An important point to be attended to in the cold storage of eggs is the correct relative humidity, too dry a temperature will cause serious evaporation, and too moist a temperature will produce mould, and the exact relative humidity most suitable does not seem to be understood even in the United States, judging from the remark reported to have been made to a refrigerating expert by a prominent commission man who observed, alluding to storage eggs: "You storage men are between the devil and the deep sea. You always shrink 'em or stink 'em," by which he meant that eggs held any length of time in cold storage would show either a considerable evaporation or a radical "musty" flavour.

The above renders it necessary to carefully provide for the ventilation of egg stores, and is the reason why absorbents for drying the air are largely used. An excellent arrangement for this purpose is that which has been already shown in Fig. 194, page 298, which, as has been already mentioned, has been designed by Mr Madison Cooper, of Minneapolis, Minn., U.S., especially for the ventilation of egg stores.

According to the above authority the following is the correct relative humidity for a given temperature in egg rooms:—

| Temperature in degrees Fahr. | Relative Humidity per cent. | Temperature in degrees Fahr. | Relative Humidity per cent. |
|---------------------------------|--------------------------------|---------------------------------|--------------------------------|
| 28 | 80 | 35 | 65 |
| 29 | 78 | 36 | 62 |
| 30 | 76 | 37 | 60 |
| 31 | 74 | 38 | 58 |
| 32 | 71 | 39 | 56 |
| 33 | 69 | 40 | 53 |
| 34 | 67 | | |

It is impossible within the space at command to deal even comparatively fully with the subject of egg storage, and to those interested the author would strongly recommend the perusal of a little work by Mr Madison Cooper entitled "Eggs in Cold Storage," and published by Messrs H. S. Rich & Co., Chicago, U.S.

FRUITS.

It may be taken as a general rule that all green fruits should not be allowed to wither.

Citrus fruits (orange, lemon, citron, lime, forbidden fruit, or shaddock, &c.) should be kept dry until the skin has yielded its moisture, upon which the drying process should be arrested.

There is no particular practice for bananas as the ripening will have to be governed according to the demand, and it may be taken that the ripening of this fruit can be manipulated at will.

Tender fruits are better placed in cold storage when just ripe as they then keep better than when brought in before being fully ripe. According to Professor Siebel sour fruit will not bear as much cold as sweet fruit. Catamba grapes will suffer no harm at 26° Fahr., while 36° Fahr. will be as cold as is safe for a lemon. The spoiling of fruit at temperatures below 40° Fahr. is due to moisture.

Tender fruits, such as pears, must be stored whilst firm, and must be very carefully handled, and they should be wrapped in paper. Once the chemical changes which cause ripening have set in it is too late to place them in cold storage. After being kept in cold storage pears will spoil very quickly on removal.

Lemons as a rule cannot be kept in cold storage for over four months, although it is stated that those stored during January, February, and March will keep good for five months.

Grapes do not keep well in cold storage, and lose most of their flavour of taste. The harder species naturally keep better than

the softer ones. Grapes lose more of their flavour when kept at a temperature of, say, 32° Fahr., than they do when kept at 40° Fahr. An important point is to carefully pick, select, and pack the fruit, and it is to be noted that a single rotten grape will taint a whole lot.

Black currants can be kept sound, fresh, and clear for ten days, after which the fruit begins to wrinkle.

Red currants can be kept sound for six weeks. Temperature 26° to 36° Fahr.

Cherries can be preserved for from ten days to a fortnight at a temperature of 36° Fahr.

Strawberries can be preserved in good condition for fifteen days, and even longer if special precautions are taken, such as surrounding the fruit with cotton wool, or placing it in sieves covered with the same material. The best temperature is found to be 30° Fahr. Peaches will keep in prime condition for a month or six weeks. The same remarks as regards selection apply equally in these cases, as, indeed, they do more or less to all fruits.

Apples must not be kept in too dry an atmosphere, as if this be done they will be wilted or withered, and their appearance spoilt; this is more especially the case when they are kept at a comparatively high temperature. On the other hand too moist an atmosphere and high a temperature will cause the apples to burst. The storage of apples may be effected either in barrels or boxes, or in bulk, first-rate results being obtainable with all provided proper precautions as to temperature and moisture are taken.

A process for preserving fruit has been invented and patented by Mr A. W. Lawton, which is said to have proved completely satisfactory in an experimental trial of twenty-one days with tomatoes, pine-apples, and grapes.

The process is founded upon the belief that fruit is provided with breathing cells, which breathe air in a similar manner to the human being, absorbing oxygen and exhaling carbonic acid, or the exact reverse of ordinary plant life. The oxygen, when inhaled, combines with the sugar or carbon which is contained in the fruit, thereby causing self-consumption, or loss of substance. In order to prevent this taking place, the atmosphere supplied to the fruit under this process is deprived of most of its oxygen, by which means it is claimed that the breathing cells of the fruit become partially closed, and thus the further ripening of the fruit is suspended.

The apparatus employed is shown in Fig. 281, and comprises a

chimney or flue A, a stove B, an air filter C, and an air-tight storage room D having a hermetically closing door E. As soon as the fruit has been placed in the room D it is sealed up, the atmospheric air driven out, and replaced by a sterilised atmosphere produced and maintained in the following way:—By means of an ordinary blower or fan F, air is forced through a stove B containing red-hot coke, whereby the oxygen is consumed and any germs or animalcula destroyed. The gases thus produced are then filtered by passing through the air filter C and cooled before entering the chamber by passing over refrigerating coils.

Whilst superintending the transportation of a shipment of fruit on board the S.S. "Para," preserved by this process, Mr Lawton lost his life through an accidental explosion of a spare store of chemicals, which

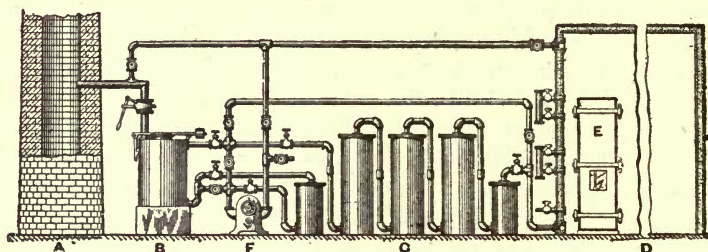

Fig. 281.—Lawton's Apparatus for Preserving Fruit. Diagrammatical View.

lamentable accident also resulted in the injury of several other persons, and in considerable damage to the vessel.

Among a few of the claims put forward by the inventor, mention may be made of the following, viz., that fruit can be picked ripe, consequently perfect, and can in that state be conveyed to this country from any part of the world, and stored on arrival here. When finally exposed for sale it will keep for a long period. And furthermore, that the process is simple and comparatively inexpensive, and that it can be applied to existing refrigerating installations in conjunction therewith. See also Marine Refrigeration, pages 419, 420.

VEGETABLES.

Green vegetables generally should, like green fruit, not be allowed to wither.

Sound onions may be maintained in good condition in cold storage

for a number of months (six or seven), but care must be taken that when placed in the store they are as dry as possible, and for this purpose they may advantageously be exposed to a dry cool wind so as to give up most of their moisture. Onions should never be stored in the same room with other goods, and on their removal the room must be thoroughly exposed to the air, well scrubbed out, and when dry the walls, floor, and ceiling should be whitewashed. It is also recommended to give the room a good coat of paint or enamel paint. Some American authorities hold that if a room has been once used for storing onions it should not afterwards be employed for the storage of eggs, butter, or other articles especially susceptible to odours.

Parsnips and salsify can be advantageously kept in cold storage under the same conditions as onions, with the exception, however, that they will stand freezing without injury. Asparagus, cabbage, carrots, celery, can be kept with little humidity.

MORGUES OR MORTUARIES.

The Morgue at Paris comprises a chamber for the reception of corpses, a chamber for storing corpses, a chamber for exposing the corpses to view, and a hall for the public, which latter is separated from the former chamber by a double screen of glass kept transparent by a continuous circulation of cold air. On their arrival the corpses are received in the reception chamber, where they are undressed and washed. Next they are placed in shells and subjected for from twenty-four hours to forty-eight hours to a temperature of -15° C., after which they are placed on view. Should any of the corpses not be identified after a certain time, if desirable, they are stored at a temperature of -6° C. The freezing shells are of metal with double walls, and the refrigeration is effected by a circulation of cold brine. Mechanical ventilation is only employed to regulate the temperature of the chambers.

In the following table will be found the temperatures considered best adapted for the cold storage of various articles, as given in the first and second editions of "Refrigerating and Ice-Making Machinery," and also those recommended by a number of other authorities, arranged in columns for convenience of comparison:—

TEMPERATURES ADAPTED FOR THE COLD STORAGE OF VARIOUS ARTICLES.

Degrees Fahrenheit.

| Article. | Wallis-Taylor. | Siebel. | Schmidt. | Getty. | "Ice and Refrigeration." | "Ice and Cold Storage." | Rane. | Madison Cooper. | London Douglas. |
|-------------------------------|----------------|---------|----------|--------|--------------------------|-------------------------|-------|-----------------|-----------------|
| Ale | ... | 32-42 | ... | ... | ... | ... | ... | ... | ... |
| Apples | 32-36 | 33 | 33-36 | 32 | 32-36 | 33-36 | ... | 31 | ... |
| Apples (summer) | ... | ... | ... | ... | ... | ... | 38-42 | ... | ... |
| Apples (winter) | ... | ... | ... | ... | ... | ... | 32-35 | ... | ... |
| Apple and peach butter | ... | ... | ... | 40 | ... | ... | ... | 42 | ... |
| Asparagus | 34 | 34 | 34-35 | 34 | 34 | 35 | 34 | 33 | ... |
| Bananas | 40-45 | 34-36 | 34 | 35 | 40-45 | 40-45 | ... | 36 | ... |
| Beans (dried) | 32-40 | ... | ... | 32-40 | ... | 32-40 | ... | 40 | ... |
| Beef (fresh) | ... | ... | ... | 37-39 | ... | ... | ... | 35 | ... |
| Beef (dried) | ... | ... | ... | 36-45 | ... | ... | ... | ... | ... |
| Beer (in casks or barrels) | 33-42 | 33-42 | 33-35 | ... | 33-42 | 33-40 | ... | ... | ... |
| Beer (in bottles) | 45 | 45 | 45 | ... | 45 | 45 | ... | 45 | ... |
| Berries (fresh, for ten days) | 36-40 | ... | ... | 35 | 36-40 | 36-40 | ... | 40 | ... |
| Buckwheat flour | 40 | ... | ... | ... | 40 | 40 | ... | 42 | ... |
| Butter | 32-38 | 32-35 | 18-25 | 32-35 | 32-38 | 25-30 | ... | 14 | 35-38 |
| Butter (to freeze) | ... | ... | ... | 20 | ... | ... | ... | ... | 20 |
| Butterine | 35 | ... | ... | ... | ... | 35 | ... | 20 | 20-35 |
| Cabbages | 34 | ... | ... | 33 | ... | 35 | ... | 32 | ... |
| Cantaloupes | 40 | ... | ... | ... | ... | 40 | ... | 40 | ... |
| Carrots | 34 | ... | ... | 34 | ... | 35 | ... | 33 | ... |
| Celery | 32-34 | 33-35 | 34-35 | 34 | 32-34 | 35 | ... | 32 | ... |
| Cheese | 32-33 | 32-33 | 28-34 | 31-32 | 32-33 | 32-33 | ... | 35 | 28-35 |
| Chestnuts | 33 | ... | ... | 33 | ... | 33 | ... | 40 | ... |
| Chocolate (to cool) | 40 | ... | ... | ... | ... | ... | ... | ... | ... |
| Cider | 30-40 | 30-40 | 30-35 | ... | 30-40 | 35-40 | ... | 32 | ... |

TEMPERATURES ADAPTED FOR THE COLD STORAGE OF VARIOUS ARTICLES—Continued.

| Article. | Wallis-Taylor. | Siebel. | Schmidt. | Getty. | "Ice and Refrigeration." | "Ice and Cold Storage." | Rane. | Madison Cooper. | London Douglas. |
|---------------------------|----------------|---------|----------|--------|--------------------------|-------------------------|-------|-----------------|-----------------|
| Grapes | 36-38 | 32-40 | 34-36 | 32-40 | 36-38 | 36-38 | 38-40 | 34 | ... |
| Ginger ale | 36 | 36 | ... | ... | ... | 35 | ... | 36 | ... |
| Hams | ... | ... | ... | 30-35 | ... | ... | ... | 20 | ... |
| Hogs | ... | ... | ... | 30-33 | ... | ... | ... | ... | ... |
| Hops | 33-40 | 33-36 | 32-40 | 35 | 33-40 | 35-40 | ... | 35 | ... |
| Hops (frozen) | ... | ... | ... | ... | ... | 28 | ... | ... | ... |
| Honey | 45 | 36-40 | 45 | 37-40 | 45 | 45 | ... | 45 | ... |
| Lard | ... | ... | ... | 34-45 | ... | ... | ... | ... | ... |
| Lemons | 36-40 | 36-45 | 33-36 | 35-45 | 36-40 | 36-40 | ... | 38 | ... |
| Liver | ... | ... | ... | 30 | ... | ... | ... | 20 | ... |
| Maple syrup sugar | ... | ... | ... | 40-45 | ... | ... | ... | 45 | ... |
| Margarine | ... | 35 | 18-25 | ... | 35 | ... | ... | ... | ... |
| Meat (brined) | ... | ... | ... | 35-40 | ... | ... | ... | ... | ... |
| Meat (canned) | 35 | ... | ... | 35 | ... | 35 | ... | 30 | ... |
| Meat (fresh) | 34 | 35 | 35-40 | ... | 34 | 35 | ... | ... | ... |
| Melons (for 3 or 4 weeks) | ... | ... | ... | ... | ... | ... | ... | 35 | ... |
| Milk | ... | ... | ... | 32 | ... | ... | ... | ... | 32 |
| Mutton (fresh) | ... | ... | ... | 33-36 | ... | ... | ... | ... | ... |
| Mutton (frozen) | 25-28 | ... | ... | ... | ... | ... | ... | ... | ... |
| Nuts (in shells) | 35 | 35-38 | 35-40 | 35-38 | 35 | 35 | ... | 40 | ... |
| Oatmeal | 40 | ... | ... | ... | ... | 40 | ... | 42 | ... |
| Oleomargarine | 35 | ... | ... | ... | ... | 35 | ... | 20 | ... |
| Oil | 35 | ... | ... | ... | ... | 35 | ... | 45 | ... |
| Onions | 34-40 | 32-33 | 36 | 32 | 34-40 | 35-40 | 34-40 | 32 | ... |
| Oranges | 45-50 | 36 | 34-36 | 35-36 | 45-50 | 45-50 | ... | 34 | ... |
| Oysters | 33-35 | ... | ... | ... | ... | 33-35 | ... | 33 | ... |
| Oysters (in tubs) | 25 | ... | ... | 35 | ... | 25 | ... | 35 | ... |

TEMPERATURES ADAPTED FOR THE COLD STORAGE OF VARIOUS ARTICLES—Continued.

| Article. | Wallis-Taylor. | Stiebel. | Schmidt. | Getty. | "Ice and Refrigeration." | "Ice and Cold Storage." | Rane. | Madison Cooper. | Louden Douglas. |
|-------------------------|----------------|----------|----------|--------|--------------------------|-------------------------|-------|-----------------|-----------------|
| Oysters (in shells) | 33 | ... | ... | 40 | ... | 30 | ... | 43 | ... |
| Ox tails | ... | ... | ... | 32 | ... | ... | ... | ... | ... |
| Parsnips | 34 | ... | ... | 34 | ... | 35 | ... | 32 | ... |
| Peaches | 45-55 | 35-45 | 34-36 | 35-45 | 45-55 | 45-55 | 36-38 | 36 | ... |
| Pears | 34-36 | 33-36 | 34-36 | 38 | 34-36 | 35 | 33-38 | 33 | ... |
| Peas (dried) | 40 | ... | ... | 40 | ... | 40 | ... | 45 | ... |
| Plums | ... | ... | ... | ... | ... | ... | 38-40 | 32 | ... |
| Porter | ... | 33-42 | ... | ... | ... | ... | ... | ... | ... |
| Pork | 34 | ... | ... | ... | ... | ... | ... | ... | ... |
| Potatoes | 36-40 | 34-36 | ... | 35 | 36-40 | 36-40 | 36-40 | 34 | ... |
| Poultry (frozen) | 28-30 | 28-30 | 20-28 | 29 | 28-30 | 28-30 | ... | 28 | 28-30 |
| Poultry to freeze) | 18-22 | ... | ... | 5-10 | ... | 18-22 | ... | 10 | 10-18 |
| Poultry (long storage) | ... | ... | ... | ... | ... | ... | ... | 10 | 10 |
| Sardines (canned) | 35 | ... | ... | ... | ... | 35 | ... | 40 | ... |
| Sauerkraut | 35-38 | ... | ... | 36-38 | ... | 35-38 | ... | 38 | ... |
| Sausage casings | ... | ... | ... | 30-35 | ... | ... | ... | 20 | ... |
| Sugar, &c. | 40-45 | ... | ... | ... | ... | 40-45 | ... | 45 | ... |
| Sweet corn | ... | ... | ... | 35 | ... | ... | ... | ... | ... |
| Syrup | 35 | ... | ... | 36 | ... | 35 | ... | 45 | ... |
| Tenderloin, butts, ribs | ... | ... | ... | 30-35 | ... | ... | ... | ... | ... |
| Tomatoes | ... | 34-35 | 38-42 | 35 | ... | 35 | 38-42 | 42 | ... |
| Tobacco | 35 | ... | ... | 35 | ... | 35 | ... | 42 | ... |
| Veal | ... | ... | ... | 32-36 | ... | ... | ... | ... | ... |
| Vegetables | 34-40 | ... | ... | ... | ... | ... | ... | ... | ... |
| Watermelons | 34 | ... | ... | ... | ... | 35 | ... | 40 | ... |
| Wheatflour | 40 | ... | ... | ... | ... | 40 | ... | 42 | ... |
| Wines | 40-45 | 40-45 | 40-45 | ... | 40-45 | 45-50 | ... | 42 | ... |
| Woollens, &c. | 25-32 | 25-32 | 28-35 | 25-32 | 25-32 | 25-30 | ... | ... | ... |

CHAPTER XVI

MARINE REFRIGERATION

Carbonic Acid Machines—Ammonia Machines—Cold-Air Machines—Arrangement of Cargo Holds and Stores—Ice-Making on Board Ship—Barges.

MARINE refrigeration offers considerably more difficulties, both as regards the machinery, and likewise with respect to the installation of the cold chambers, than is the case with land installations.

As regards the machinery, in the first place, the space at command is necessarily limited, and consequently it is absolutely necessary that the design should be such as to occupy the minimum of room, whilst affording the maximum of efficiency.

The agent or medium employed should likewise be one of a non-inflammable nature, and also one having no deleterious action on copper, which metal has to be employed in the condenser in order to enable sea water to be used for cooling purposes.

With reference to the insulation, the settlement or shaking down due to the continuous vibration experienced on ship-board has to be contended with. For this reason an excellent material to use for insulating purposes in marine installations is what is known as "Nonpareil" cork, which is largely employed in the American Navy. This material consists of granulated cork, made by compressing cork chips under hydraulic pressure in iron moulds, and then heating the mass while in the mould to a temperature of about 500° Fahr. This treatment has the effect of liquefying the natural gum of the cork, and forming the interstices between the granules into small closed air spaces. On the cooling of the moulds the gum hardens, and the mass becomes, as it were, a solid sheet of cork. The weight of "Nonpareil" cork is only 1 lb. per square foot, and it is consequently about the lightest insulating material in use. It is said to be 13 per cent. superior, as a non-conductor of heat, to hair-felt, and 40 per cent. superior to sawdust. Slag, or mineral wool, or silicate cotton, is also used very extensively, and with great success for marine work.

As regards the most suitable system of refrigerating machine for

use on board ship, a wide diversity of opinion still exists. In spite of comparing unfavourably, as regards efficiency, with machines using agents possessed of greater latent heat, cold-air machines might still be advantageously used for short voyages, and where coal could be obtained cheap. There are no chemicals to be carried, no danger from bursting of pipes or joints giving out, and the machine is comparatively simple and easily managed.

Of machines working on the compression system, and employing a refrigerating agent of a more or less volatile nature, carbonic acid machines offer advantages which have caused them to be very largely employed for marine purposes, a fact which has been proved in a practical manner by Messrs J. & E. Hall, Ltd., alone having fitted over 1800 machines working on this system on board ship.

The qualities which render CO_2 particularly suitable for use on ship-board are: First, that this agent admits of a much smaller compressor being employed relatively to the refrigerating power produced; second, that having no corrosive action on any of the metals, it thereby allows, as above mentioned, of copper being used in the condenser; and third and lastly, but not least, it is not only non-inflammable, but has the power to extinguish fire, and is therefore perfectly free from danger in this respect. As regards the danger to life through an escape of this gas, its specific gravity being greater than that of air (CO_2 spec. grav. 1.529 air = 1) causes it to fall to the lowest level, and in practice it is found that no danger is to be apprehended from the escape of a moderate quantity of CO_2 if the space be not unduly confined and is fairly well ventilated. For this reason the Board of Trade's instructions to surveyors, issued in June 1901 *re* refrigerating machines, contains the following: "The surveyors are therefore informed that, unless they are aware of any special reasons to the contrary, refrigerating machines in which carbonic anhydride is employed as the working agent may be placed in the engine-rooms of steamships, provided the weight of the charge which would be released by a breakdown of the machine, or of one portion of a duplex machine, does not exceed 200 lbs.

"When it is proposed to fit a machine using a greater charge than this is an engine-room, full particulars of the case, including size, and method of ventilating the compartment, and weight of charge proposed, should be submitted for consideration."

The principles upon which the marine types of refrigerating machines work are naturally precisely the same as those employed for service on land, and therefore the differences are merely of a

structural nature, adapted to render them more especially suitable to the construction of vessels. It is purposed, therefore, in this chapter, to merely give a few examples of machines especially designed for marine purposes, referring readers for further particulars as to the special distinctive details of construction adopted by the various makers to the more lengthy and complete descriptions given of their land types of machines.

Fig. 282 shows one of J. & E. Hall's carbonic acid machines of the horizontal duplex marine type, which has been specially designed for large installations on board ship. This machine is fitted with a compound steam cylinder, the high-pressure cylinder being on one side and the low-pressure cylinder on the other, a double-acting compressor being driven by a tail-rod from each cylinder. The two machines are so arranged that either both sides can be worked together, or, if desired, one half, that is to say, one compressor with its condenser and evaporator can be disconnected, when the other half can be worked by itself. Each compressor delivers the compressed carbonic acid through an independent condenser, which is placed in the base of the machine or built separately as may be found to be most convenient, and in which sea water is circulated round the condenser pipes through which the carbonic acid passes.

This type of machine is also built in pairs mounted on the same base or bed-plate, with compound steam cylinders, the high-pressure cylinder being located on the one side, and the low-pressure cylinder on the other. The two compressors are, in this type, driven by tail-rods from the steam cylinders, and the cranks are placed at right angles, an arrangement which tends to ensure an even turning movement. Each compressor delivers the compressed carbonic acid to an independent condenser, which is usually placed in the base of the machine, and in which sea water is circulated round the condenser pipes through which the carbonic acid passes. In connection with each side of the machine a separate evaporator or refrigerator is provided, which consists, as in the land type, of coils of pipes, in which the liquid carbonic anhydride evaporates or gasifies, and which coils are enclosed in a steel casing, in which the brine is circulated by means of pumps. The brine thus cooled is, in one arrangement, circulated through electrically-welded grids of piping, each containing about 200 feet of pipe, which grids are divided into sections, each section having a separate flow and return from the evaporator or refrigerator, and valves being provided for regulating the quantity of cold brine in each section as required by the temperature in the holds.

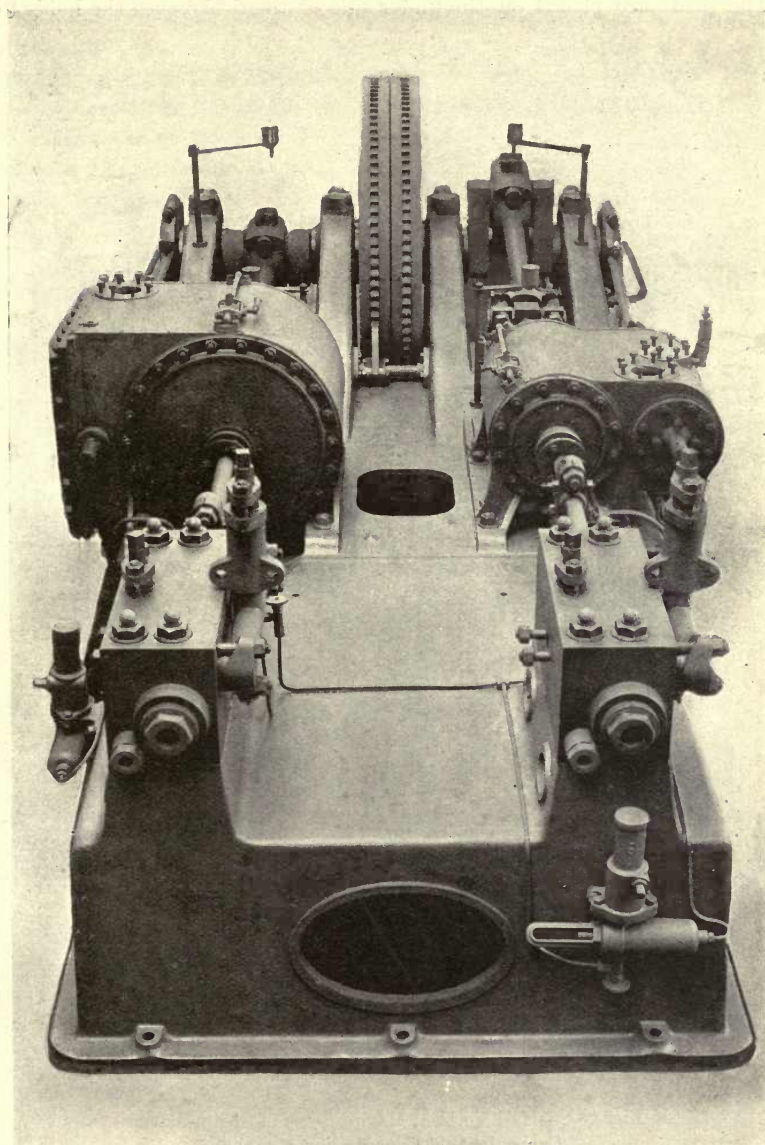

Fig. 282.—Hall Horizontal Duplex Marine Type of Steam-driven Carbonic Acid Compression Machine.

The grids are placed on the under side of the decks over the holds to

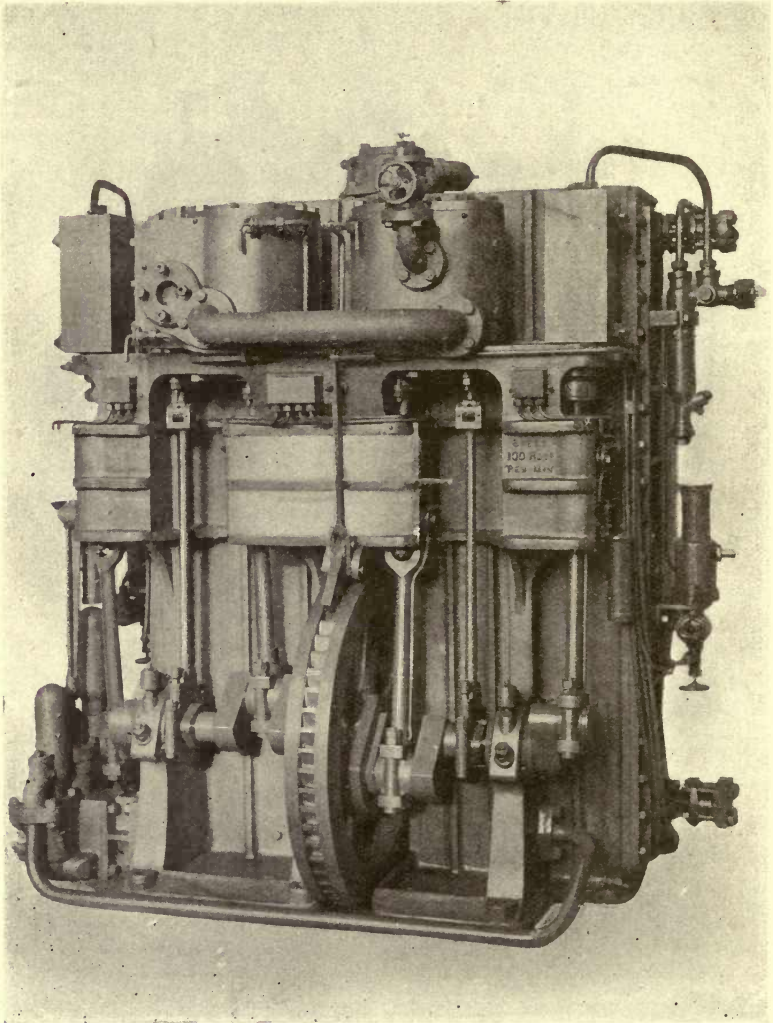

Fig. 283.—Hall Vertical Marine Type of Steam-driven Carbonic Acid Compression Machine.

be refrigerated, preferably between the deck beams, so as to occupy no valuable space, and to be protected from damage.

In another arrangement the brine is passed through a suitable battery of pipes, over which air is drawn by fans, and is passed through the holds to be cooled.

In Fig. 283 is illustrated one of the vertical duplex marine types of machines built by the same firm. This pattern of machine is especially designed for preserving provisions on passenger steamers and on steam yachts, and for making ice. The machine is fitted with compound steam cylinders and two compressors, in connection with each of which

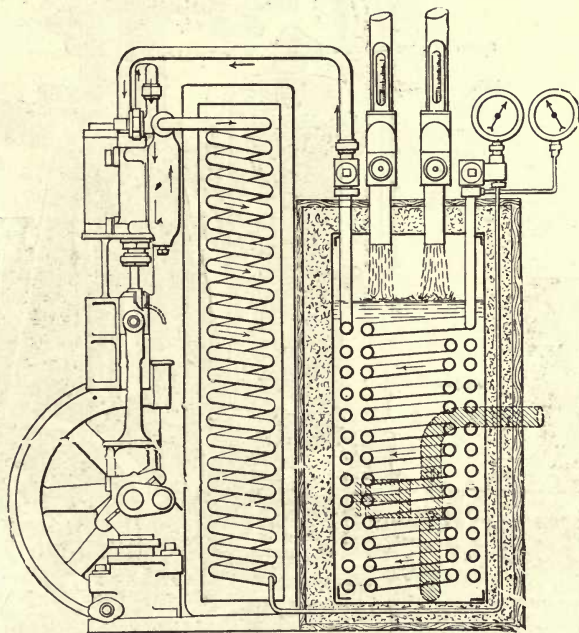

Fig. 284.—Hall Small Marine Type of Steam-driven Carbonic Acid Compression Machine. Vertical Central Section.

latter is a condenser and an evaporator or refrigerator, there being thus two entirely independent complete carbonic acid machines, either of which can be disconnected, and the remaining machine run with the compound engine.

Smaller marine-type machines (Fig. 284) are also made by this firm, having a single vertical steam cylinder, and the compressor arranged alongside of it, both being fixed to a casting containing the condenser coils, which latter are made of copper, and behind which casting is

another secured to it, and containing the evaporator or refrigerator coils.

Turning to machines working on the ammonia compression system, Fig. 285 shows a marine type of the De La Vergne machine. It is a vertical single-acting compressor, actuated by a high-pressure horizontal steam engine, fitted with a special governor, which admits

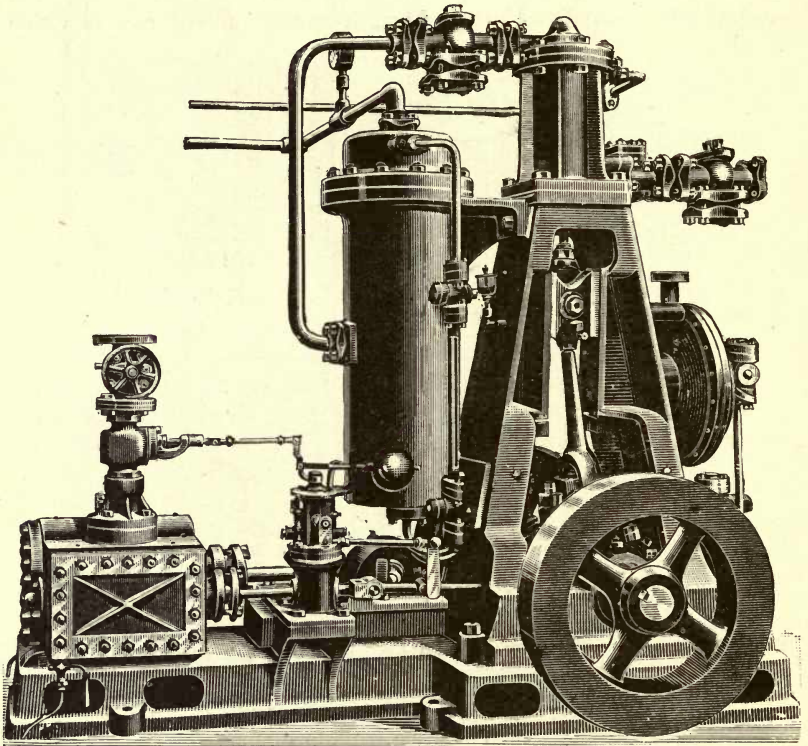

Fig. 285.—De La Vergne Vertical Single-Acting Marine Type of Ammonia Compression Machine.

of the steam supply being determined for wide ranges of speeds when required, say for any speed between 30 and 300 revolutions per minute, without interfering with the running or stopping the machine. The construction of the compressor cylinder is identical with that illustrated in the enlarged sectional view, Fig. 17.

In the marine type of Linde machiné a single compound ammonia

compressor is employed, which, as in the case of the land type of machine, is also driven by means of a tandem compound engine. The ammonia condenser is situated below the compressor, and is fitted with sets of endless coils or worms. By the use of a compound compressor, that is to say, one wherein the compression of the ammonia gas is effected in two stages, the loss from re-expansion of gas left in the clearances is completely got rid of, as such loss is experienced in the low pressure compressor cylinder only, none taking place in the high-pressure compressor cylinder.

Figs. 286 and 287 show two ammonia machines of the horizontal marine type, designed by Mr S. Puplett, the first being a horizontal ammonia compressor connected with a vertical engine, all mounted upon the same bed-plate, and the second a com-

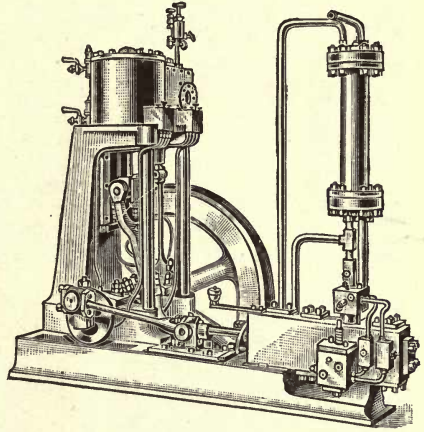

Fig. 286.—Puplett Horizontal Marine Type of Steam-driven Ammonia Compression Machine.

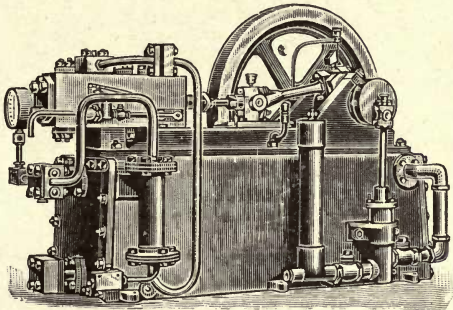

Fig. 287.—Puplett Horizontal Marine Type of Belt-driven Ammonia Compression Machine.

compact form of horizontal belt-driven ammonia compressor, especially designed for marine work.

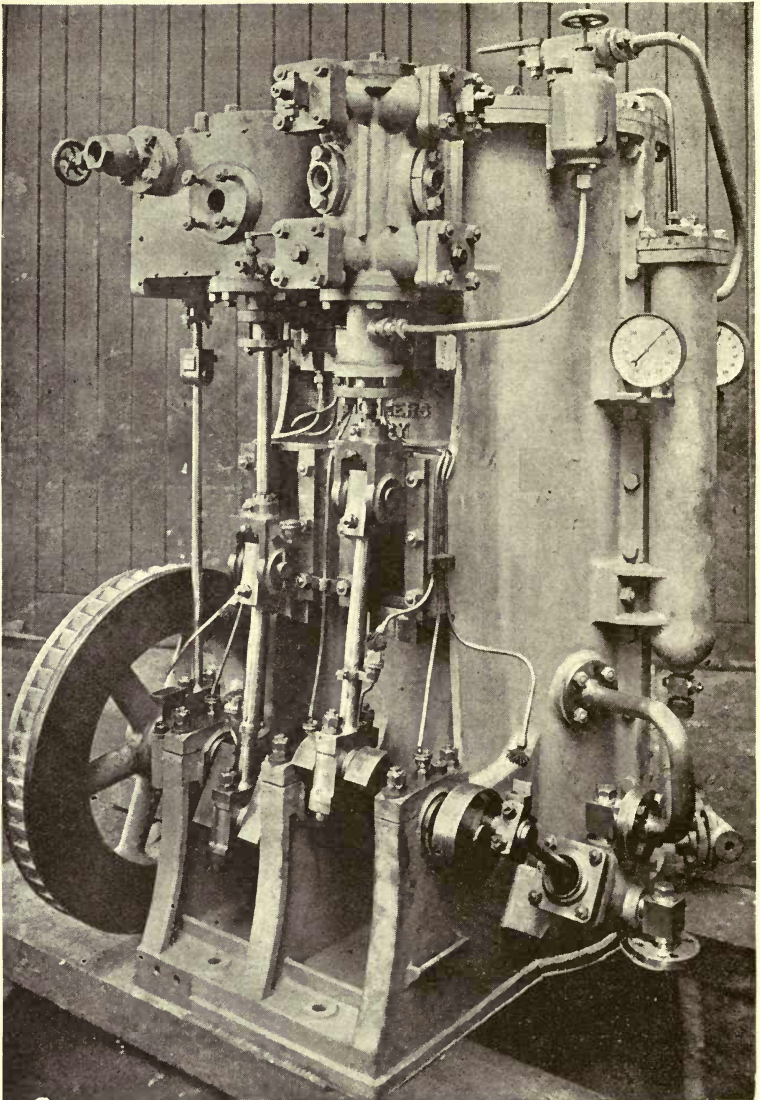

Fig. 288.—Haslam Vertical Self-contained Marine Type of Steam-driven Ammonia Compression Machine.

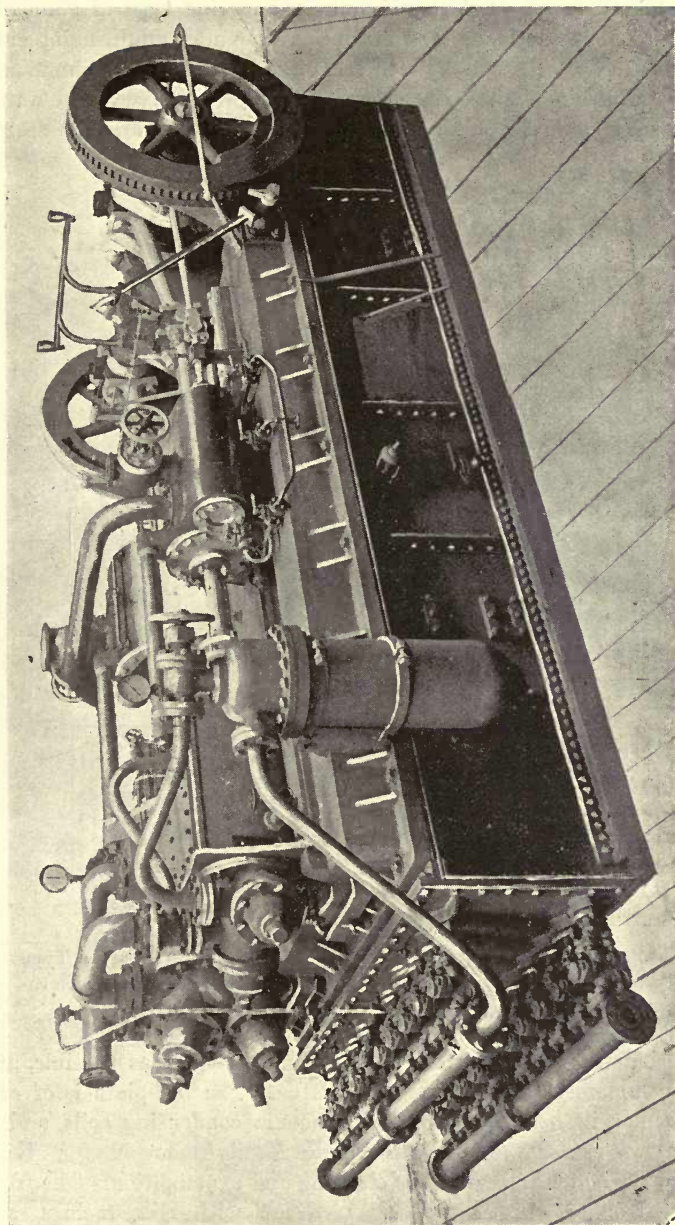
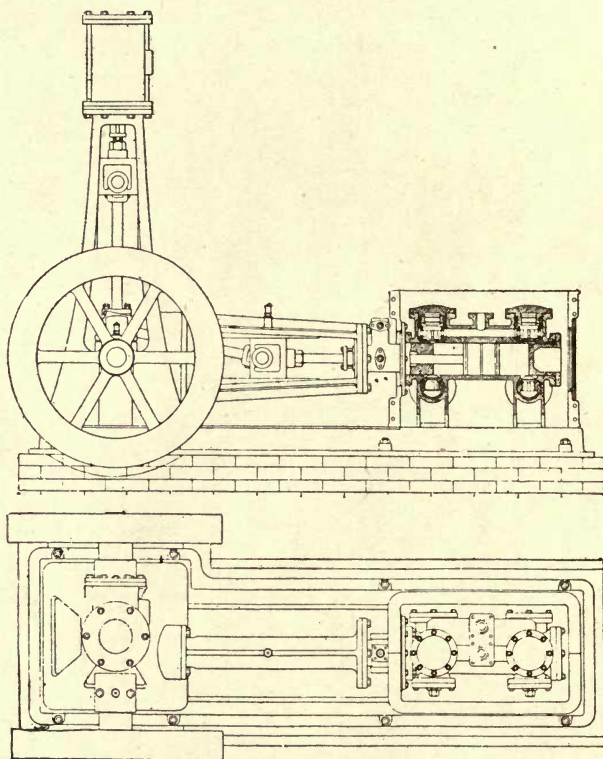

Fig. 289. — Haslam Horizontal Marine Type of Steam-driven Compound Ammonia Compressor.

Fig. 288 shows a vertical self-contained marine type of ammonia compression machine made by the Haslam Foundry and Engineering Co., Ltd., Derby. As will be seen from the illustration, the ammonia compressor, steam engine, separator, condenser, receiver, and water pump are all mounted on the same bed or base plate, and the design



Figs. 290 and 291.—Kilbourn Horizontal Self-contained Marine Type of Steam-driven Double-Acting Ammonia Compressor. Plan and Elevation, partly in Section.

is such that they occupy as small an amount of space as possible, and form a completely self-contained apparatus. The bed-plate is of cast iron, circular in form, contains the ammonia condensing coils, and is made in two parts; the back part being readily removable for giving access to the condensing coils for cleaning and examination. The front part is strongly constructed and provided with ribs, facings, and

brackets to receive the steam cylinder, ammonia compressor, crank-shaft, and other working parts of the machine.

A water pump, shown on the right-hand side of the illustration, and worked by a disc crank on the end of the crank shaft, is provided for circulating water through the condenser, and when desired a brine pump is also fitted.

This machine is made in sizes from half-ton ice-making capacity per day up to three tons ice-making capacity per day. The three-ton machine will maintain from 16,000 to 32,000 cub. ft. at 32° Fahr. in ordinary storage, and requires 9 I.H.P. in a temperate climate and 10½ I.H.P. in a hot climate. Three hundred gallons of condensing water are required per hour, 55° on and 80° off. The weight of the machine is 103 cwt., and the dimensions 6 ft. 8 in. in depth, 6 ft. in width, and 7 ft. 8 in. in height.

Fig. 289 is an illustration showing the latest horizontal marine type of Haslam compound ammonia compressor. This machine consists of a compound engine, and compound ammonia compressors, the gas being thus compressed in two stages. The whole is mounted upon a cast-iron bed-plate which in turn is mounted upon a wrought-iron tank, which latter contains the ammonia condenser coils.

The system of cooling employed with this machine is either brine pipes placed in the holds, or the air-blast system; an installation on the latter plan, which the above firm put into the New Zealand Shipping Co.'s steamer "Ruapehu," consists of a series of direct expansion cooling pipes or coils, placed in nests, over which the air is circulated by means of a powerful fan. The air is cooled in passing through the coils to any desired temperature, is then circulated through the holds, and then returned again to the fan.

Figs. 290 and 291 show in plan and in elevation, partly in vertical section, a self-contained marine type of horizontal double-acting ammonia compressor and vertical steam engine, on the Kilbourn system,

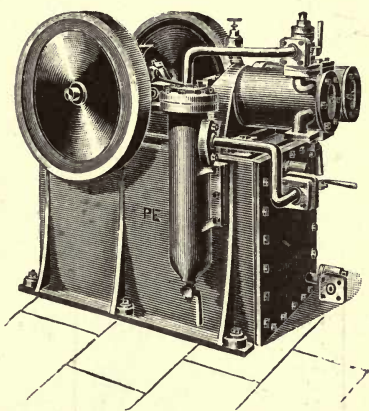

Fig. 292.—Kilbourn Horizontal Double-Acting Marine Type of Belt-driven Ammonia Compressor.

which is extensively used on American steamers. Fig. 292 shows a belt-driven Kilbourn marine type ammonia compression machine.

This double-acting horizontal ammonia compression machine is driven by a vertical engine, which is fixed upon the same base or bed-plate in such a manner as to render the complete machine very compact in design, one of sufficient power to keep a storage capacity of 22,000 to 26,000 cub. ft. at a suitable temperature for chilled beef, 40,000 to 44,000 ft. for frozen mutton, or of making about 6 tons of ice per day of twenty-four hours, requiring only a floor space of 10 ft. by 10 ft., including that required for both the refrigerator and the condenser.

The compression cylinders are enclosed in water jackets, and are fitted with Webb's patent arrangement of suction valves. The stuffing boxes and glands are of the Kilbourn double pattern, that is, each box is formed with a chamber placed centrally therein, and into which oil is injected constantly for sealing purposes by a small force-pump fixed on the side of the bed-plate, and worked from a lever connected to the compression pump crosshead. The steam cylinder piston rods are coupled by means of forked connecting rods to the same crank pins as those of the compression pumps.

Improved forms of gas-tight joints and of a stop-cock or valve,

which will be found described on pages 262 to 264, and 253, have been also devised, and were patented in 1882 by the same inventor.

The arrangement of the machine illustrated in Fig. 292 is very compact, having been designed with that end more especially in view;

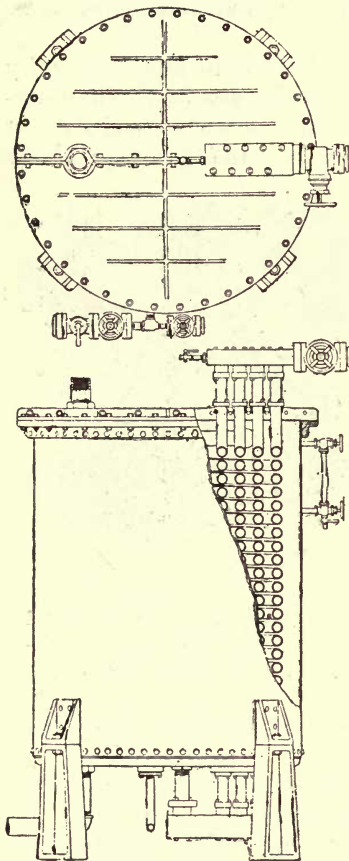

Figs. 293 and 294.—Marine Type of Ammonia Condenser. Plan and Elevation, partly in Section.

and for which purpose the ammonia condenser is placed underneath the compressor.

Figs. 293 and 294 show, in plan and sectional elevation, the marine type of condenser used in conjunction with these machines.

The cargo holds of the steamships *Campania* and *Lucania* are refrigerated with machines of the Kilbourn type. The meat-carrying chambers in each of these vessels consists of three chambers situated forward on the orlop or lower deck, and having a total capacity of 20,000 cub. ft., which renders them able to carry 2,700 quarters of beef. The chambers are very carefully insulated, the walls consisting, as shown in Fig. 295, first of a double thickness of tongued and grooved boards A, A, having a layer of waterproof paper B between them, next a 2-in. layer of good quality hair-felt C, and another double thickness of tongued and grooved boards D, D, with a similar layer of paper E, between them, and finally an inch air space F between the latter and the inner or iron deck, the whole being well varnished.

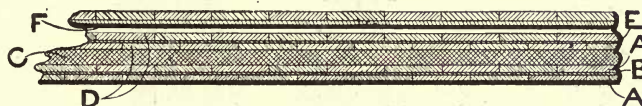

Fig. 295.—Insulation of Cargo Holds on board S.S. “*Campania*” and “*Lucania*.” Transverse Section.

The brine cooling pipes, which are of heavy 2-in. galvanised tube with malleable cast return bends, are placed on the ceiling between the deck beams, thus economising head room, and the rails for the meat-hooks are of $1\frac{1}{8}$ -in. galvanised round iron, firmly clipped to the beams supporting the decks. The meat hooks which are placed upon the latter, for carrying the quarters of beef, are of steel galvanised. Thermometer tubes from the upper deck are provided to each chamber, so that the temperature in any part of the chamber may be ascertained when desired.

Fig. 296 is a plan showing the general arrangement of the machine-room. A pair of compressors are employed. A, A are the steam-engine cylinders; B, B the compression cylinders; C, C the ammonia condensers; D, D the liquid ammonia reservoirs; E, E, the refrigerators; F is a brine circulating pump of the duplex pattern; G is a manifold or distributing pipe to the different cooling pipes in the chambers; H is the collecting pipe at the top of the refrigerator. It will be seen that the cold parts of the machine are enclosed in a separate chamber

having walls insulated in a similar manner to those of the meat-carrying stores or chambers, thereby preventing as far as practicable loss through absorption of heat.

The compressors are of an ice-producing capacity of 12 tons a day, the compression cylinders being 6 in. in diameter by 12 in. stroke, and the steam cylinders 8 in. diameter by 12 in. stroke.

The ammonia condensers *c*, which are more clearly shown in

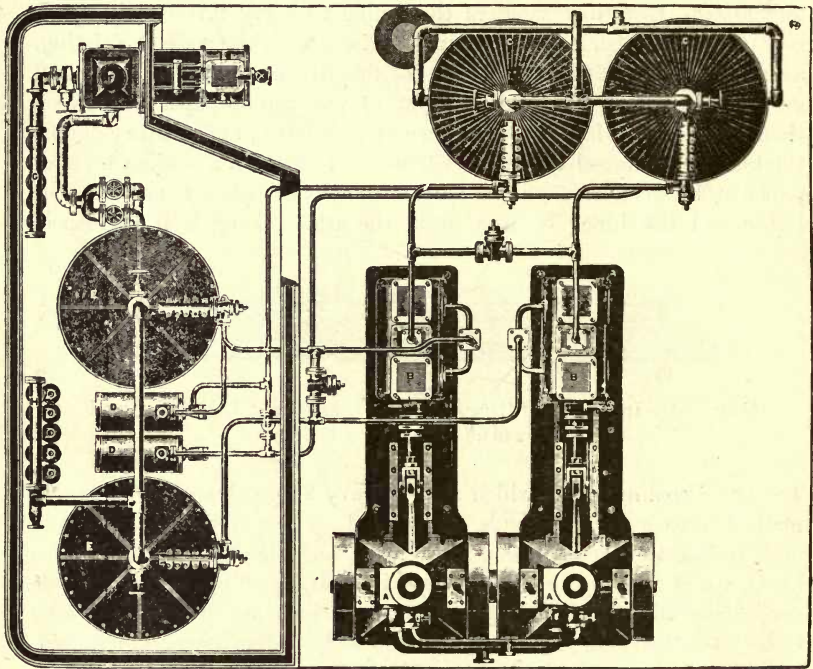

Fig. 296.—Plan of Refrigerating Machine-room on Cunard Steamers.

Figs. 293 and 294, are constructed of a cylindrical form, the shells being made of wrought iron, and the covers of cast iron, and they are fitted with concentric coils of $1\frac{1}{2}$ -in. galvanised iron pipe, connected together at their extremities by means of tee-pieces made of malleable castings. The ammonia condensers are in this case, moreover, carefully lagged with teak wood. The water for use in the ammonia condensers *c* is supplied and circulated by means of a duplex steam pump (not shown in the drawing), located in the forward boiler-room of the steamship.

The ammonia gas after compression in the compressors B, and liquefaction in the condensers C, under the combined pressure of the pumps or compressors B, and the cooling action of the condensing water circulating on the exterior of the coils or worms in the condensers, is delivered to the reservoirs D for the liquefied ammonia, through small-bore pipes. From these reservoirs the liquid ammonia is admitted through suitable graduated expansion or regulating valves to the lower ends of the expansion coils in the refrigerators E, wherein the liquid ammonia again vaporises or gasifies, abstracting the heat required for this process from the brine surrounding the expansion coils, and being again returned to the compressors, and so on *ad infinitum* in the manner already described. The absolute working pressure in the refrigerators is about 30 lbs. per square inch.

The brine having been reduced to the desired temperature in the refrigerators, passes into the system of brine circulating pipes, and maintains the atmosphere of the cold stores or chambers at a temperature suitable for the proper preservation of the meat. The circulation of the brine is effected by the brine pump F, which draws the cooled brine from the bottom of the refrigerators E, and discharges it through the distributing tee-piece and valves, or manifold G, to the different sections of the cooling pipes in the chambers, and returns it through a similar tee-piece, manifold or distributor H to the top of the refrigerator to be again cooled. The return brine pipes are each fitted with a regulating valve and a thermometer.

The cold air or provision stores or chambers on board of the "Campania" and "Lucania" are fitted up with refrigerating plants, on the De La Vergne ammonia compression system.

The refrigeration is effected on the brine circulation, and not upon the direct expansion system, a solution of calcium chloride being the agent or medium employed, and this solution is reduced to a very low temperature in the usual manner, by the expansion of the ammonia gas or vapour, in coils or pipes submerged therein, and is circulated by a special pump through the system of cooling or refrigerating pipes, which latter are fixed to the under side of the roof or ceiling of the cold store or chamber.

The method employed for the insulation of the store or chamber is shown in Figs. 297 and 298, which are vertical sections through the roof or ceiling thereof. A, A are the refrigerating pipes; B, B the meat rails; C is a filling of sawdust; D, D are layers or skins of tongued and grooved boarding; E is a layer of hair-felt; and F, F are layers of tarred waterproof paper. The brine pipes are divided

into two sections or sets, thereby admitting of any necessary repairs being effected in one section, without in any way interfering with the circulation of the cold brine through the other section, and special means are also provided for withdrawing the brine from one set or section without interfering with the working of the other.

The ammonia compressor is of the vertical single-acting type, and

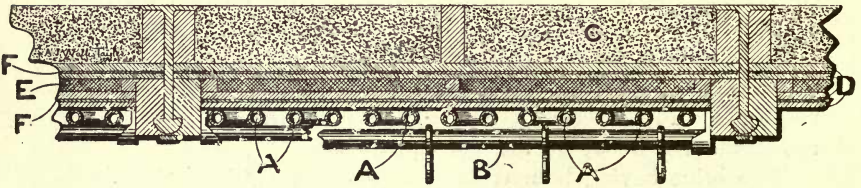

Fig. 297.—Insulation of Provision Stores on board S.S. "Campania" and "Lucania." Transverse Section through Ceiling.

is actuated by a high-pressure horizontal steam engine. The compressor cylinder is $4\frac{1}{2}$ in. in diameter, by 9 in. stroke, and the steam engine is of $2\frac{1}{2}$ H.P., and is fitted with a special governing arrangement, by means of which the steam supply is determined, the speed being capable of variation within a wide range (say between 30 to 300 revolutions) without interfering with the running of the machine.

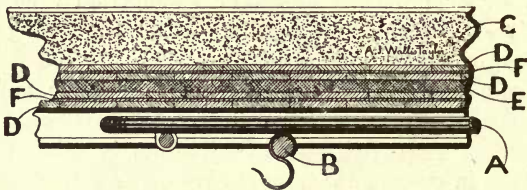

Fig. 298.—Insulation of Provision Stores on board S.S. "Campania" and "Lucania." Vertical Longitudinal Section through Ceiling.

The construction of the compressor is substantially similar to that described with reference to Fig. 285, and the oil separator and other parts only differ from the arrangement shown in the general view of a complete installation shown in Fig. 19, in that the ammonia compressor is of the single-acting type, and by reason of the smaller capacity of the present plant, and the absolute necessity on shipboard for economising every cubic inch of room possible. The operation of the

apparatus is, however, in every way identical, and the description of the complete installation will apply equally well in this case.

The machine is capable of making 5 cwt. of ice daily, in addition to the performance of the refrigeration required in the cold storage or provision chamber.

Fig. 299 shows an Enock electrically driven ammonia compression machine, marine pattern. In this arrangement, as shown in the illustration, the ammonia compression machine is coupled direct to the spindle

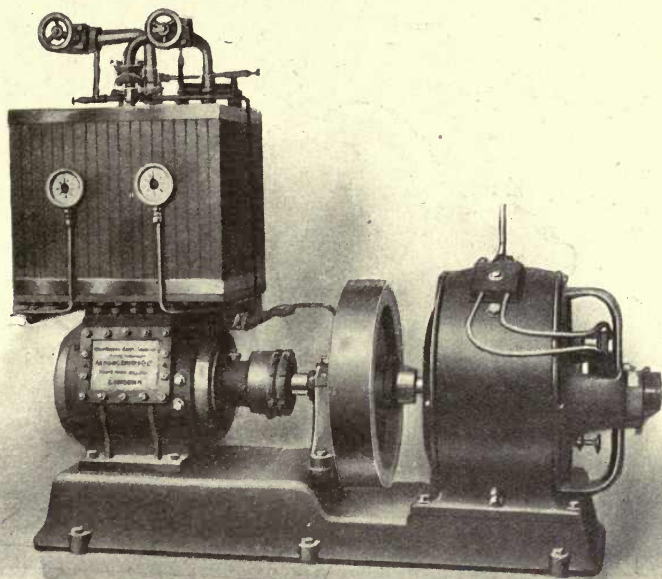

Fig. 299.—Enock Electrically-driven Ammonia Compression Machine, Marine Pattern.

of a direct current slow speed motor mounted on an extended bed-plate. The compressor is of the double cylinder pattern, single acting, with from 20 to 30 lbs. pressure of gas only upon the oil sealed packing, escape of gas being thus practically an impossibility, the joint being made on a revolving shaft instead of a reciprocating rod. The compressor is of the Enock safety self-oiling type, which will be found described in a previous chapter.

As has been already mentioned, in spite of their inferior efficiency,

In certain cases cold-air machines can be used to some advantage, on board men-of-war for instance, which vessels remain at sea for some

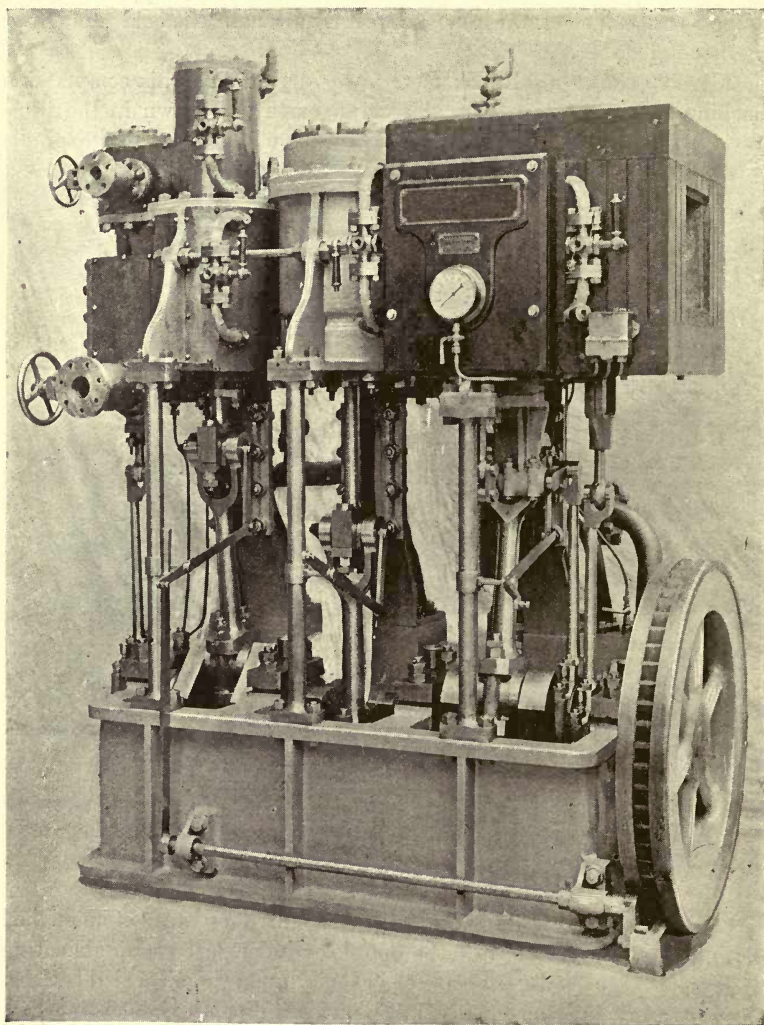

Fig. 300.—Hall Vertical Marine Type of Steam-driven Cold-Air Machine.

years, and a difficulty might be experienced in obtaining carbonic acid, or other volatile agent.

Fig. 300 illustrates a Hall vertical marine type of steam-driven cold-air machine, fitted with compound steam cylinders, which is the pat-

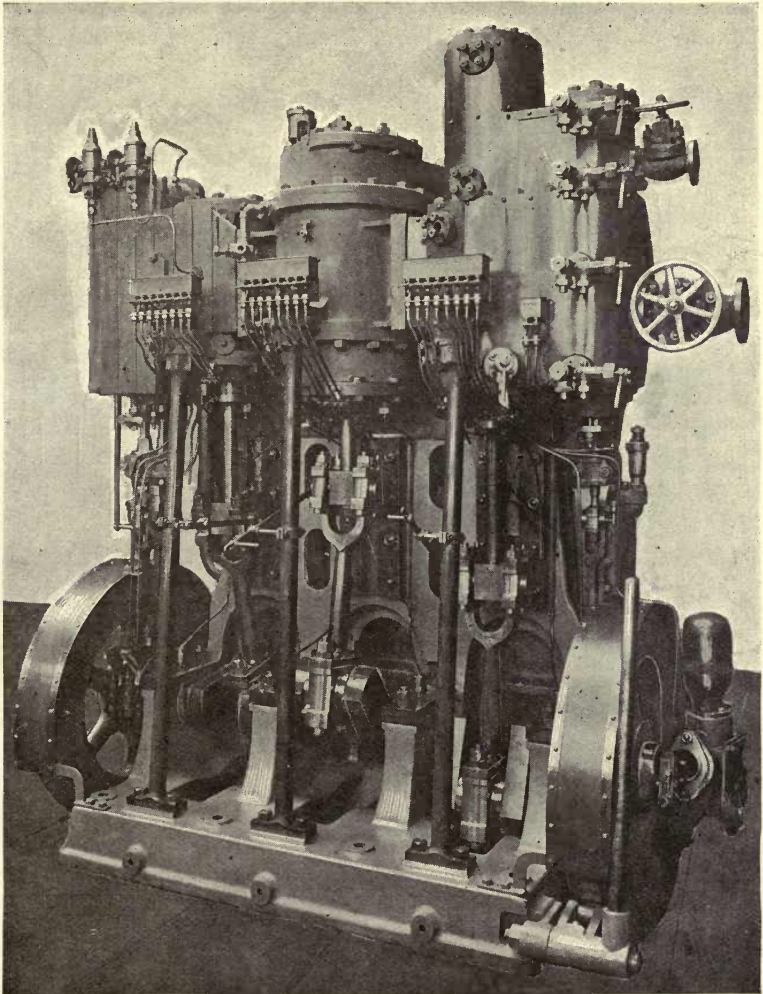

Fig. 301.—Haslam Vertical Marine Type of Steam-driven Cold-Air Machine.

tern of machine supplied by Messrs J. & E. Hall, Ltd., to H.M. Admiralty, and to other navies. Another marine type of air compress-

sion refrigerating machine, made by the above firm, is of a horizontal pattern, also fitted with compound steam cylinders.

Figs. 301 and 302 show two recently designed marine types of Haslam cold-air machines. That shown in Fig. 301 is from a photograph of one of two similar machines recently supplied to the Royal

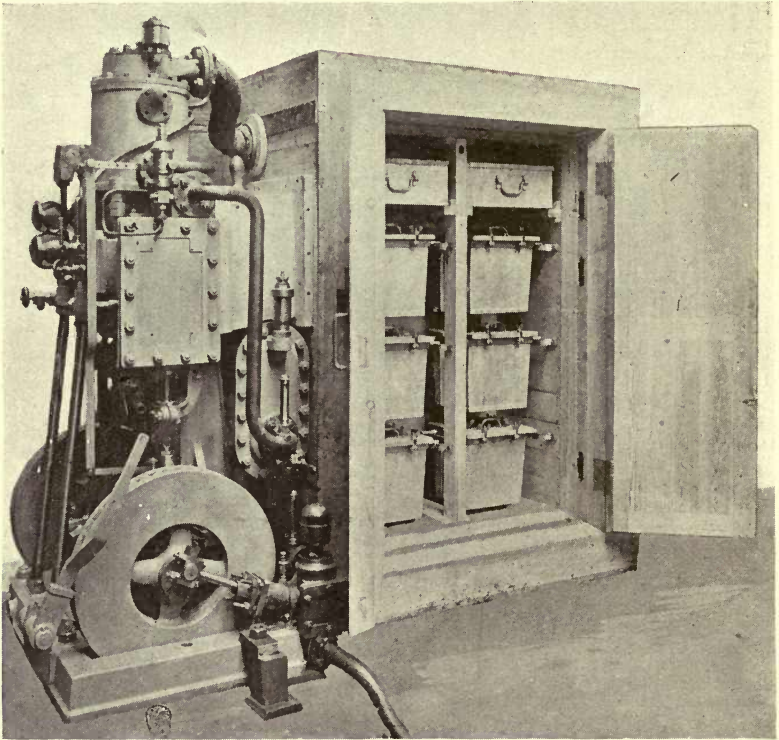

Fig. 302.—Haslam Vertical Marine Type of Steam-driven Cold-Air Machine and Ice-making Apparatus.

yacht. Fig. 302 is a pattern which has been supplied to the British Admiralty for the manufacture of 85 lbs. of ice per day of twelve hours on warships.

In a marine installation the pipe or trunk for admitting the cold air is usually fixed along one side of the cold store or chamber in the hold, as near the top or ceiling as possible, the return pipe or trunk

being placed at the opposite side of the chamber. As in land installation, the inlet trunk or pipe is fitted with a number of apertures governed by sliding doors; these are only opened to a very slight extent at the end nearest the machine, and gradually more and more as they approach the end furthest therefrom, thus equalising the temperature in the chamber.

The most important point is to ensure the cold air being thoroughly circulated and penetrating every portion of the chamber, and thermometers should be hung in different positions therein to form a check to the deck pipe ones. Where a cold-air machine, unprovided with a special arrangement for drying the air, is used, the snow box must be cleared out repeatedly, to prevent the passages, and also the slide valve ports, from becoming blocked up, and the trunk or inlet pipe must be cleaned once a day or oftener.

For marine purposes the cold-air refrigerating machine was first in the field, and is still preferred before other systems by many engineers, and by the Admiralty; but owing to certain defects in the earlier machines, other systems have been tried. The difficulty with any new system is the necessity for carrying a considerable store of chemicals, and serious accidents have resulted from the use of these machines on ship board.* There is also the danger of running short of these chemicals by any accident to the vessels in which they are stored. Now, with cold-air machines no chemicals are required, the pressures adopted are low, and possibility of accident to the machine is even more remote than accident to the main propelling engines.

A new cold-air machine has recently been designed by Messrs T. & W. Cole, Ltd., to overcome the defects of the earlier machines of this type, in which each defect has been combated with marked success, as described in previous chapters.

Previous to storing the carcasses in the cold storage place, a thorough inspection thereof should be made, and any damage to the walls made good. When the cold storage space is filled, the hatches should be made tight by caulking with oakum, or, preferably, they should be fitted with india-rubber insertions, which afford a greater certainty of air-tight joints being made.

An arrangement of a small cold storage chamber, such as is very frequently constructed on board a large passenger steamer, is shown in sectional plan in Fig. 303. The refrigeration is effected by means of a Lightfoot, Haslam, or other cold-air machine of the vertical type.

The arrangement of this cold storage chamber, which is practically

* *Vide* leading article in *The Engineer*, 3rd January 1902.

similar to that of those used on the passenger steamers of the Peninsular and Oriental Company, will be very readily understood from the drawing, wherein A is the meat room, the temperature of which is kept down to about 20° Fahr., and wherein are situated the ice-making or freezing tank B, the ice cans or cases B¹ B¹, and the ice store C. D is the vegetable room, which is maintained at a temperature of about 40° Fahr., and in which are placed the water-cooler E, wine closet or cooler F, and hanging room G.

It is, of course, obvious that the ice-making or congealing tanks or boxes, employed on shipboard, must be considerably modified in order

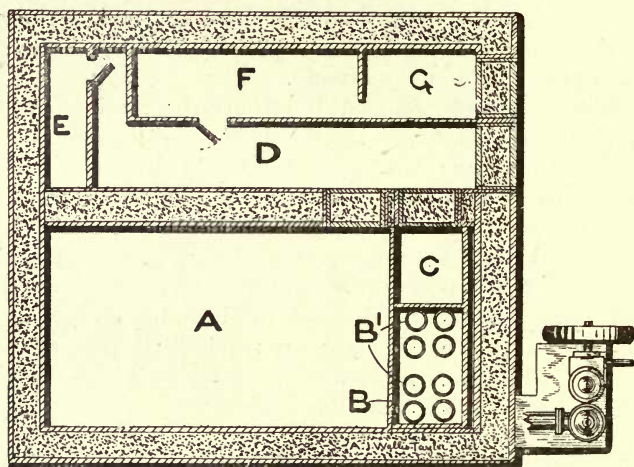

Fig. 303.—Arrangement of Cold Storage Chamber on board Large Passenger Steamer. Sectional Plan.

to provide for the motion of the vessel. In Fig. 304 is shown in plan, and in longitudinal and transverse section, a type of marine ice-making box or tank designed by Mr Kilbourn, and installed by him on the International Navigation Company's vessels "St Louis" and "St Paul." In the left-hand top corner of the illustration is shown an end view of the refrigerating coils.

Carcasses should be packed as close together as possible, consistent with safety, a space being left round the sides for the circulation of the cold air. The space allowed for the storage of a 56-lb. carcass in the refrigerated spaces on steamers is 2.8 cub. ft.

The proper stowage of a fruit cargo in the cold store or chamber

is likewise a matter that must be carefully attended to, in order to ensure its arrival at its destination in good condition. The essential point to be insisted upon is that clear spaces or clearances of at least $\frac{1}{2}$ -in. be left between each tier of cases and between the cases and the bottom, sides, and ceiling of the chamber. These clearances can be managed by the insertion of laths of a suitable thickness between the cases. Passages should be also provided for admitting of inspections of the state of the fruit being made during the voyage.

The best temperature to maintain for fruit is one of from 45° to 55° Fahr., and this should be evenly kept up throughout the entire cargo. It must be borne in mind that the slightest degree of frost

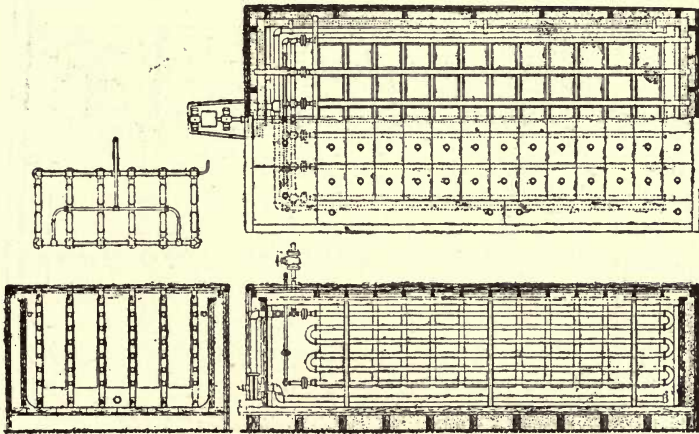

Fig. 304.—Ice-making or Congealing Tanks or Boxes for use on Shipboard.
Plan, Side, and End Elevations, and Detail View

will destroy a whole cargo of fruit. It will generally be found sufficient to run the refrigerating machine about twelve hours per day in hot latitudes and six hours per day in cooler ones.

It is most important that the temperature should not be permitted to vary to any great extent during the voyage, and as considerable difficulty is experienced in attaining this end, it is desirable to provide a check upon those in charge. For this purpose a thermograph, or self-registering thermometer * is, or ought to be, provided in connection with each chamber fitted for the carriage of fruit, so that an accurate record may be kept of the actual changes of temperature that have

* For description of thermograph or self-registering thermometer see pp. 574, 575.

taken place during the voyage, and it can be seen at a glance on arrival whether the fruit has been carried under proper conditions or otherwise.

Fig. 305 is a transverse section of a ship fitted with an arrangement of Sir A. Seale Haslam. Chambers as shown, are cooled by pipes, and are fitted with rails for hanging the meat in the ordinary manner. Channels are provided by which air can be supplied to the chambers through suitable openings, and also channels by which air can be drawn from the chambers through other openings. On the right is a

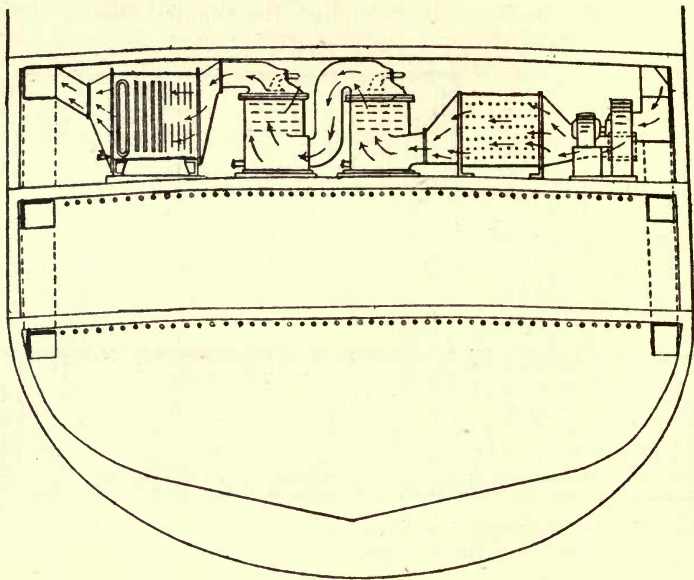

Fig. 305.—Haslam Method of Sterilising the Cold Air for use in Ships' Holds.

fan for circulating the air through a chamber heated by steam pipes or by a jet of steam, or by both, and provided with a trap for removing condensed water. The air passing through this chamber is heated to, say, 300° Fahr. and may be treated to a steam injection, as it is well known by experiments that to effectually deal with bacterial growth and organisms it is necessary in many cases to moisten the air with steam at a high temperature, as well as to bring it in contact with hot surfaces at a high temperature. The heated and sterilised air is next passed into a tower where it is washed and cooled by a cold-water

spray supplied by a pump, and from thence into another or cooling tower in which it is washed and further cooled by a spray of cold brine supplied by another pump. Baffle plates as shown are provided in the towers and also water and brine outlets. From the latter tower the cooled air passes to a drying chamber fitted with baffle plates and water or steam pipes, the latter being used if necessary to slightly raise the temperature of the air if it has been made too cold in the cooling tower. A water outlet is provided in this drying chamber. Essentially the operation consists in sterilising the air circulated through a chamber cooled by means of cold pipes or surfaces consisting in heating the air, then washing and cooling it, and lastly drying it by passing it over cold dry surfaces.

BARGES.

An important type of portable refrigerator is that adapted to meet the requirements of barges which it is desirable to maintain at a low temperature without encumbering them with machinery, or rendering in any way necessary the employment of special labour to take charge of the same.

The frozen meat, as a rule, arrives in good condition on board the vessels, and deterioration in quality usually takes place, as has been already mentioned, during its transference to the cold stores on land, and again during the subsequent delivery thereof to the retailer, when the meat is exposed to temperatures frequently much higher than what is required to preserve it in good condition. The Pulsometer Engineering Co., Ltd., claim to have devised a successful system of refrigeration for barges.

Since the beginning of 1888, moreover, the London and Tilbury Lighterage Co., Ltd., have had barges fitted with special refrigerating apparatus successfully plying upon the Thames, the meat landed by them being invariably in good condition, and not infrequently at a lower temperature than when first discharged from the vessel.

CHAPTER XVII

REFRIGERATION IN DAIRIES

Methods of using Mechanical Refrigeration in Dairies—Examples of Mechanical Refrigerating Installations in Dairies—Milk or Cream Coolers—Ice-cooled Creamery Refrigerators—Air-Circulation System—Cylinder System—Insulation of Dairy or Creamery Refrigerators—Size of Ice Chambers—General Particulars—Materials—Ice Refrigerating Machine.

THE term dairy, used in its widest sense, indicates a place where milk is preserved and prepared for sale or for family use, or converted into cream, butter, cheese, &c.

The various applications of refrigeration in the dairy are summed up as follows by Mr Loudon Douglas in a paper read by him before the Cold Storage and Ice Association :—(1) The cooling of town's milk. (2) The cooling of separated cream in an auxiliary creamery or separator station. (3) The cooling of separated and ripened cream in a main dairy or central creamery, as well as cooling water to wash butter whilst being worked, and cooling a butter store or cold room. (4) Regulating the temperature of cheese-ripening rooms and cooling rooms in which cheese is stored. (5) To the storing of eggs, &c.

Butter is an unstable product. It is at its best when freshly made. Strictly speaking, deterioration begins at once, and it will become noticeable sooner or later according to the conditions under which the butter is kept. The most important condition in this respect is that of temperature, because no other condition has anything like the same influence in the preservation of butter. The preservation of butter means the checking to a greater or less extent of the processes of fermentation that affect the flavour, and which are inevitable in all butter, but it has never been found that even such extreme low temperatures will preserve the flavour indefinitely, although it has been proved beyond doubt that the lower the temperature the longer it will be preserved, other things being equal. Fortunately there is a certain period in the life of all good butter during which it may be considered to be at its best. Assuming that the butter has been well made, the

duration of this period depends almost entirely on the temperature at which the butter is kept.

Refrigeration is used in dairies, both for ensuring an ample supply of cold water and for cooling stores or chambers, the former being an essential for successful manufacture in hot weather, and the latter enabling butter to be kept in prime condition until a favourable opportunity for disposing of it presents itself. Either mechanical or ice refrigeration is now employed in most dairies, mechanically produced cold, indeed, being acknowledged to be absolutely essential wherever a large quantity of milk has to be handled, whilst the small refrigerating machine, of comparatively recent introduction, can be advantageously employed in establishments with limited outputs, except in localities where natural ice can be stored at a figure as low as between two and three shillings per ton, and artificial cold be so economically produced by this means as to render mechanical competition practically impossible.

There are two methods of using mechanical refrigeration in a dairy—direct cooling and accumulator cooling. In the first or the direct cooling method the machinery is capable of performing the required refrigerating work without the aid of brine storage, and is ready to cool milk directly after being started. This system necessitates a larger outlay at first, but is afterwards the most economical system to work. In the accumulator system a cold brine storage tank is provided, and the refrigerating machine is started to cool a stock of brine some time before the milk is to be cooled. The result of this arrangement is that a small machine is capable of cooling some two or three times the quantity of milk.

The total expenditure of power is greater than in the case of direct cooling, but the first cost is less. For accumulator cooling plants brine storage tanks should be made narrow and oblong so as to fit conveniently against a wall, or round and high so as to occupy little floor space, or shallow to go on the top of the cold room. In all dairies where the milk is not despatched soon after being chilled, a cold room is required, which also serves for the purpose of keeping butter, cream, cheese, or other dairy produce.

Fig. 306 illustrates a complete milk cooling plant, with warm milk tank and milk pump, built by A. G. Enock & Co. The machine is of the firm's ammonia (NH_3) self-contained type, in which the condenser coil is placed in the compressor jacket, and the gauges are mounted thereupon. Where a Pasteuriser is in use, it is arranged to deliver direct to the milk receiver.

It is desirable that milk or cream can be rapidly chilled to between 40° and 50° Fahr., and modern competition renders it important that this operation should be performed at as small an expense as possible.

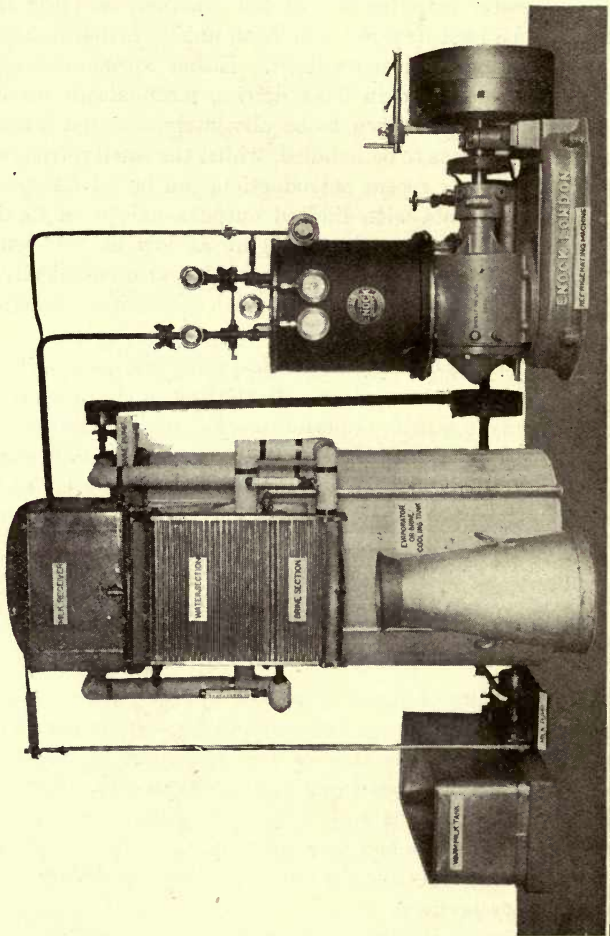

Fig. 306.—Complete Milk Cooling Plant with Warm Milk Tank and Milk Pump on the Ammonia Compression System.

The Enock double cooler, either of the flat, round, or conical type, with a water circulation from town or farm supply in the upper section, and a brine circulation from the refrigerating machine in the lower section, forms an efficient method of effecting the above cooling. New or

Pasteurised milk can be reduced in temperature to 60·5° Fahr. with cooling water at 60° Fahr. In the lower section the brine circulation cools the milk down to 40° to 50°, or lower if required.

The plant shown in Fig. 306 operates as follows:—The cold brine at 25° to 35° Fahr. is drawn by the brine pump from the brine cooling tank, delivered through the lower section of the milk cooler, and after chilling the milk, returns warm to the brine cooling tank, none being wasted. The brine cooling tank contains the evaporator coils in which the refrigerating medium evaporates, causing a very low temperature and absorbing the warmth from the brine. The refrigerating gas is drawn out of the coils by the compressor, which compresses and discharges into another coil placed in a tank of water forming the condenser. The warmth in the gas is “rendered sensible” by compression, and the condenser water carries off this “sensible heat,” causing the gas to condense or liquefy.

The liquid refrigerant then passes through an “expansion” or regulating valve into the refrigerator coils, where it again evaporates and cools the brine, the operation of evaporation, compression, and liquefaction being continuously repeated.

In the arrangement (Fig. 307) an ammonia compression machine of the Kilbourn improved type, driven by means of belt gearing from a gas engine, is used. This cream cooler is fixed against the wall of the cold store or chamber, a portion of which latter only is shown in the drawing. The cream cooler is constructed of tinned copper, and is fitted with small wrought-iron coils without internal joints, similar coils being likewise provided in the water-cooling tank, a portion of which is shown on the top of the cold store or chamber. The refrigeration is effected on the direct system, the ammonia gas or vapour being permitted to expand into the coils of pipe in the cold store or chamber and of the cream and water coolers.

An installation on the Hall carbonic anhydride (CO_2) system for cooling milk supplied to the Express Dairy Co., Ltd., London, is shown in Fig. 308. The plant consists of a single-acting compressor cut from a solid steel forging mounted on a vertical cast-iron base, the compressor being of the Hall standard type described on pages 132 to 138 with oil seal gland and pressure lubricator, and driven by a single-phase alternating current electric motor.

The condenser is contained in an enclosed casing, so that the water after passing through it, can rise to an overhead storage tank.

The evaporator coils are contained in a specially enlarged casing having a capacity of 400 gallons of brine. This enables the machine

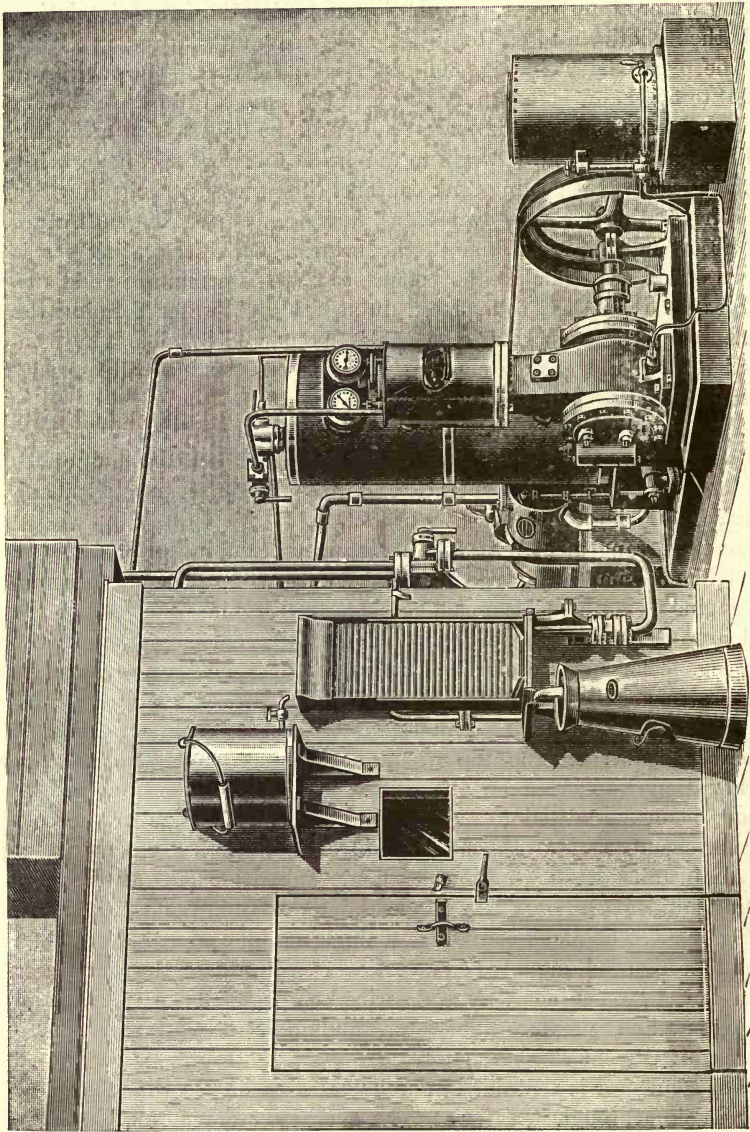

Fig. 307.—Installation of Ammonia Compression Machine in a Dairy.

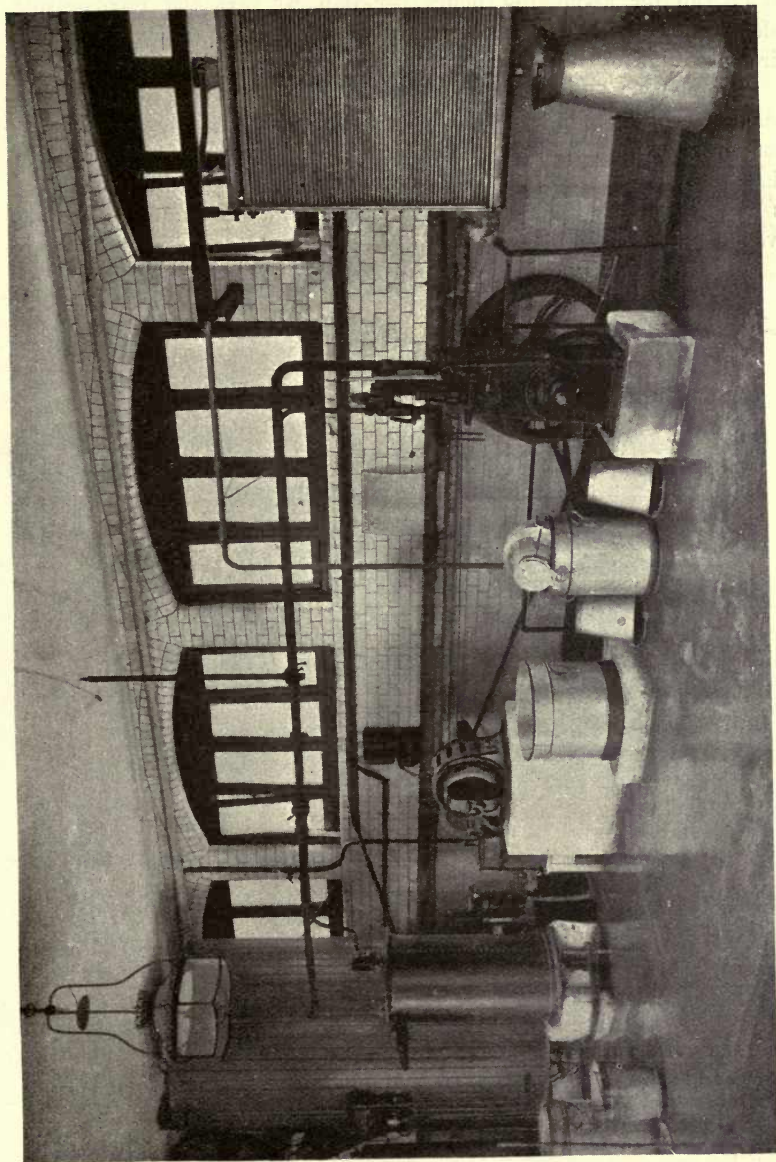

Fig. 308.—Milk Cooling Plant on the Carbonic Acid System, Express Dairy Co., Ltd., London.

to be run for about ten hours per day, so that the refrigerating effect is accumulated and stored in the cold brine which is rapidly circulated during the time that milk cooling is going on.

The plant is arranged to deal with a total of 1,000 gallons of milk per day, cooling being carried out for one hour in the morning and one hour in the afternoon, 500 gallons being passed over the cooler at each time of cooling. The cooler is in one section, through which the brine is circulated from the refrigerating machine, and the milk in passing over it is cooled down to about 40°.

Fig. 309 shows an arrangement for cooling milk, constructed by

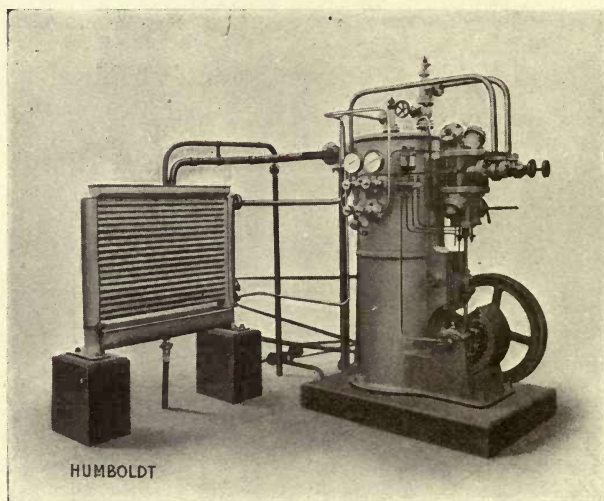

Fig. 309.—Installation for Milk Cooling on the Sulphurous Acid System.

the British Humboldt Engineering Co., Ltd., London. The compressor is on the sulphurous acid (SO_2) system, and one of the company's vertical type of machine, and is connected with a milk cooler adapted for direct evaporation.

A plant erected by the Swiss Co-operative Society at Geneva comprises two buildings—one containing the machinery, the other the dairy and cheese factory. The supply of milk is obtained from societies of farmers in the vicinity of the city, who have depôts to which the milk is delivered morning and evening, and where it is cooled to the temperature of the service water, and placed in hermetically closed churns containing from 30 to 40 litres. The following

particulars of the installation are given in "L'Industrie Frigorifique":— The milk collected at the dépôts is delivered to the dairy in the city in the morning and evening. On its arrival the milk is weighed, filtered, and after being cooled by passing it through a Baudelot cooler (see Figs. 300 and 301) having a double circulation of service water and cold brine, is delivered into tanks, in which it is kept at a temperature of 3° C. The cooling of the cold room in which the milk is stored is effected by a circulation of cold brine through pipes having radiating gills, and it is maintained at -6° C. The milk which arrives in the morning remains in the cold room until the evening; that which is received in the evening is delivered on the morning following. The distribution is made in square churns with rounded corners, having each a capacity of from 40 to 45 litres, and four of these churns are placed in each hand-cart. Each churn has a draw-off cock opened by a special key, and to prevent, as far as possible, agitation of the milk during its withdrawal it is delivered through a tube to the bottom of the cans, and these are thus filled from the bottom upwards. Provision is made on the hand-carts for ice cooling during the summer.

Any milk not sold on the rounds is returned to the dairy, where it is made into butter and cheese. The skim milk resulting from butter making is made into cheese.

The dairy has a sale for from 15,000 to 20,000 litres of milk a day. The power required is from 30 to 40 H.P., and steam is also required for cleansing purposes. The refrigeration is produced by a sulphurous acid (SO₂) compression machine of a capacity of 25,000 frigories) about 99,200 B.Th.U.), the brine being maintained at a temperature of -2° to -5°, and the tank having very large dimensions so as to form an accumulator. The condensing water is cooled by means of an open-air evaporative surface condenser situated on the roof of the building.

It was formerly held that the freezing of butter by causing a rupture of the fat globules produced a deterioration in the quality of the butter after thawing, but this idea has been now abandoned, and was never borne out by the practical experience of butter merchants. In fact, for the storage of butter for any lengthened period of time in hot climates, or for a transport by rail over long distances, freezing is usually advisable, as it has been found that butter so treated is far superior to that which has been chilled or kept in ordinary cold storage. Frozen butter both retains its flavour and body better than the other, and what is of considerable importance, is less easily affected by bad odours or other contamination. This result,

however, depends to a great extent upon the care that has been bestowed upon making the butter, viz., whether it has been washed quite clean, to what extent it has been worked in the butter-worker, and to the precautions that have been taken in packing whilst in a chilled condition. See also pages 437 and 438, and *ante*, pages 385 and 386.

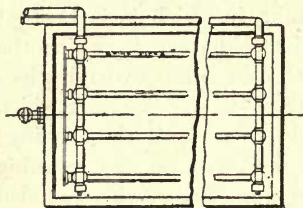

Fig. 310.—Sandbach Combined Cream Cooler and Heater. Plan.

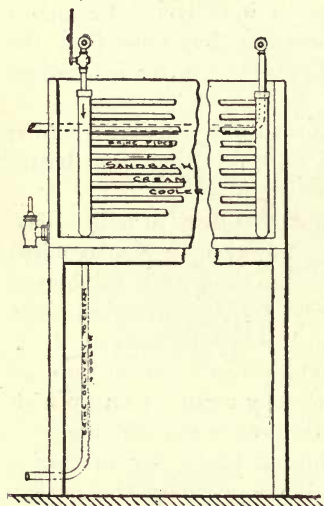

Fig. 311.—Sandbach Combined Cream Cooler and Heater. Elevation.

It may here be impressed on those concerned in the storage of butter that the greatest precautions should be taken to protect that commodity from contact with the gases due to decomposition, or with the minute particles that may be contained in the air of the cold-storage room or chamber, and which the butter will absorb very freely.

An ordinary form of milk or cream cooler consists simply in a pan fitted with a false bottom, through the space or clearance between which and the real bottom a circulation of cold or refrigerated water is maintained. The coolers in most general use are either of a cylindrical form, such as the Danish circular coolers, or they have flat corrugated sides; both types are fitted with top and bottom troughs.

Figs. 310 and 311 show in plan and elevation the Sandbach combined cream cooler and heater, which is said to be a very good system for the rapid refrigeration of cream.

The apparatus consists essentially of the following parts:—A ripening vat and combined cooler and heater, and a mechanical agitator driven off the main shafting. The cooling or heating apparatus is so designed that it presents a large cooling or heating surface in a comparatively small space, and when employed in the former purpose can be used in conjunction with any description of refrigerating machine, either for cooling cream or for the production of iced water.

Fig. 312 is a circular capillary cream cooler. This type of cooler, which is much used in Belgian dairies and creameries, is made in various sizes, the largest having a cooling capacity of about 200 gallons per hour from 65° to 52° Fahr. It can be used with any refrigerating machine, and the cold brine is pumped through the cooler, the cream passing over the exterior.

In all large dairies the Pasteurisation of milk is now become part of the ordinary routine, and this process creates a demand for additional refrigerating machinery, it being absolutely essential to reduce the temperature after Pasteurisation as rapidly as it can possibly be effected.

Cream coolers of the submerged type are said to reduce trouble of cleansing to a minimum.

A bulletin entitled "Creamery Cold Storage," written by Mr J. A. Ruddick, the Dairy Commissioner, Canadian Department of Agriculture, goes very fully into the subject of ice cooling and contains much valuable information. The following particulars are abstracted from this source.

For small or medium-sized creameries the first cost of installation and the annual expense of operation put the mechanical system out of the question. The following are examples of creamery refrigerators designed by Mr Ruddick, adapted to be cooled by ice, but it will be understood that the buildings with certain simple modifications would be suitable for the installation of machinery for mechanical refrigeration.

Although it may be possible to secure rather lower temperatures with the cylinder system than can be obtained with the air-circulation system, all things considered, a lower average temperature is usually found where the air-circulation system is in use. Both the ice chamber and the cold-storage room are thoroughly insulated. Figs. 313 and 314 show plan and section of a creamery refrigerator on the air-circulation system. It will be seen that there is a connection between the two rooms which provides for the circulation of air over the ice and through the cold-storage chamber. The working of such a refrigerator is automatic, and requires only to

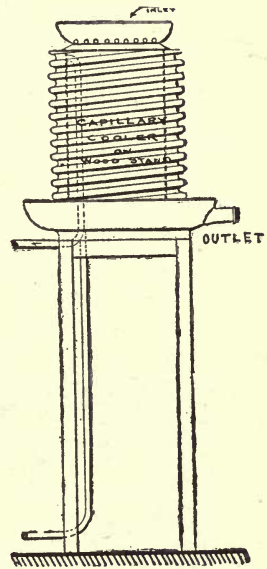

Fig. 312.—Capillary Cream Cooler. Elevation.

be regulated by the opening and closing of the slides that control the circulation of air. The ice is not covered as the thorough insulation of the walls of the ice chamber is depended on to prevent undue waste.

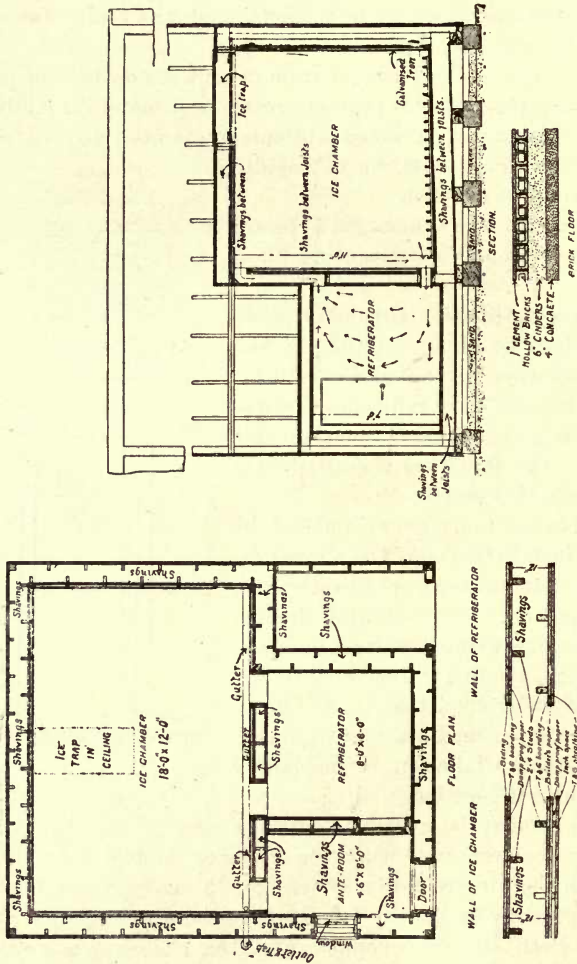

Fig. 314.—Sectional View.

Fig. 313.—Plan View.

Creamery Refrigerator on the Air Circulation System.

In this system galvanised-iron cylinders about 1 ft. in diameter are placed in the cold storage room so as to extend from the floor to the ceiling and opening into the room or loft above. A row of these cylinders should extend along at least one-fourth of the wall

space of the storage room. The cylinders are filled from above with crushed ice and salt, the proportion of which may be varied according to the temperature desired. The larger the proportion of salt the better the results will be, until the maximum is reached at about 1 part of salt to 3 of ice. Drainage must be provided to carry off the water from the melting ice, and the outlet should always be trapped in order to prevent the passage of air. The ice for this system is usually stored in an ordinary ice shed, covered with sawdust, cut hay, or other insulating material. The cylinders must be kept full in order to secure the maximum of refrigeration. The labour of breaking the ice and filling the cylinders is very considerable and constitutes one of the chief objections to the cylinder system. Where the refrigeration depends upon the daily performance, by the butter-maker, of this item of labour, it is very apt to be more or less neglected. If the cylinders are allowed to become partially empty, there is a corresponding rise of temperature in the storage room, and this is what very often occurs. The cylinder system is the cheapest to instal, because the storage room only need be insulated, but the large amount of labour involved in keeping the cylinders properly filled, and the cost of the salt, make the operation of this system somewhat expensive. Where there is plenty of cheap labour and someone to take sufficient interest in the question to see that the work is properly attended to, there is no doubt but this system will give good results, as far as ice goes, for the storage of butter. Fig. 315 shows plan and section, and Fig. 316 details, of a creamery refrigerator on the cylinder system.

In the construction of insulated walls, the best practice at the present time provides for an outer and an inner shell, as nearly as practicable impervious to air and dampness, with a space between to be filled with some non-conducting material. The width of the space will depend on the filling to be used and the temperature to be maintained in the storage room. For a creamery cold storage constructed of wood there is no better material for filling spaces than planing-mill shavings. The weight of shavings required to fill a given space will depend somewhat on the kind of wood from which they are made, and also to some extent on how tightly they are packed, but a fair average is from 7 to 9 lbs. per cubic foot of space. They should be packed sufficiently to prevent future settling. See also chapter on Insulation, pages 329 to 365.

All inside sheathing should be of spruce, because of its non-odourless character. The inside surface of ante-rooms and cold storage

rooms should receive a coat of shellac or hard oil. This will permit of the walls being thoroughly washed and disinfected to destroy spores of mould. Whitewash is also used as an interior finish. It is cheap and can be renewed from time to time. A little salt mixed with whitewash is said to harden it, and thus prevent it from rubbing off when touched.

If the inside sheathing of the ice chamber is coated with paraffin

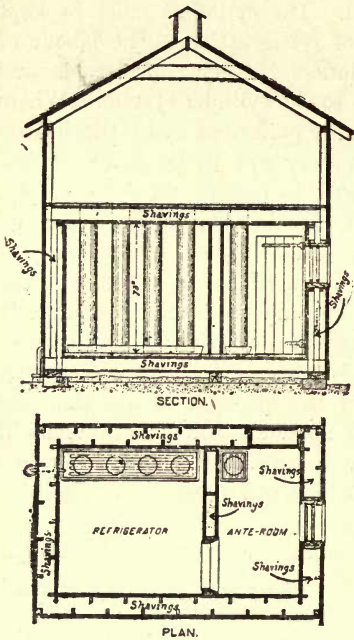

Fig. 315.—Plan and Section.

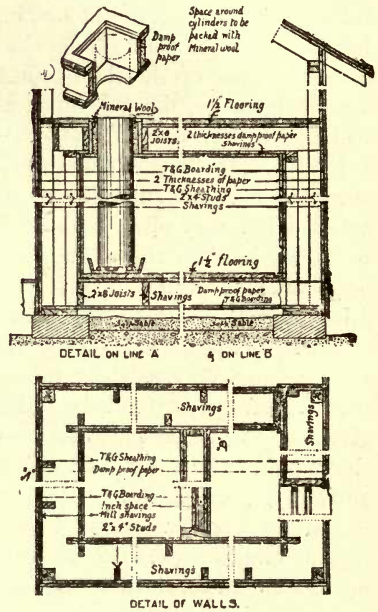

Fig. 316.—Detail Views.

Creamery Refrigerator on the Cylinder System.

wax, like a butter box, the lumber will be preserved and moisture prevented from getting into the insulation.

It is impossible to lay down any rule as to the total quantity of ice required for creameries with a given output, as so much depends on what the ice is used for, and also on the nature of the water supply. In many creameries, where there is an ample supply of cold water, no ice is used for cream cooling, while for others a large quantity is provided for that purpose. If a Pasteuriser is used, the extra cooling

required increases the consumption of ice very considerably. It is important, however, to estimate correctly the size of the ice chamber required for a cold storage on the circulation system. Where this system is used the supply of ice for cream cooling purposes should be kept separate from the cold storage supply. The ice chamber should not be opened during the summer except for occasional examination. The quantities given in the following table will be found to be about right for average circumstances :—

| Pounds of Butter made during Summer Months. | Tons of Ice required for Butter Storage only. | Size of Ice Chamber in Cubic Feet. |
|---|---|------------------------------------|
| 200,000 | 140 | 5,000 |
| 100,000 | 80 | 3,000 |
| 50,000 | 50 | 2,000 |

Where ice is required for cream-cooling purposes, and it generally is, about one-half the quantity given in the table will be required in addition. This can be stored in an ordinary ice shed and covered with sawdust.

Creamery refrigerators on the air-circulation and on the cylinder systems consist of—(1) An insulated ice chamber, where the ice is kept without any covering. (2) A cold storage room, where the packages of butter for export only shall be stored. (3) An ante-room, to receive retail butter and to protect the storage room against the entrance of warm air. Both cold storage room and ante-room are cooled by the circulation of the air which passes over the ice in the ice chamber. The situation should be at the north end of the creamery, or sheltered from the direct rays of the sun if possible.

The size will be determined by the output of the creamery. Butter should be shipped every week wherever possible, and in this case the cold storage room should not be much larger than necessary to hold a week's make, with convenience for handling the packages. A room 7 ft. high by 8 ft. sq. inside will hold conveniently 120 boxes, piled six high. The ante-room should be large enough so that the door can be conveniently closed before opening the door of the cold storage room.

As regards light, it is not desirable to have a window in the cold storage room. Sufficient light can be had from a lamp or candle when necessary. A window may be put in the ante-room.

Good insulation should be provided on all sides of the refrigerator

around cold storage room; and ante-room, whether adjoining the ice chamber or any other part of the creamery, must be equally well insulated.

Wood.—All lumber employed must be thoroughly dry and sound without loose knots or shakes, and must be odourless. Spruce and hemlock are the best in the order named. Pine is not suitable for inside sheathing, on account of its odour. All boards employed should be dressed as well as tongued and grooved. Unseasoned lumber must be carefully avoided. When building in winter, fires must be kept going so as to have all materials as dry as possible. This is very important, as dampness in insulation destroys its efficiency.

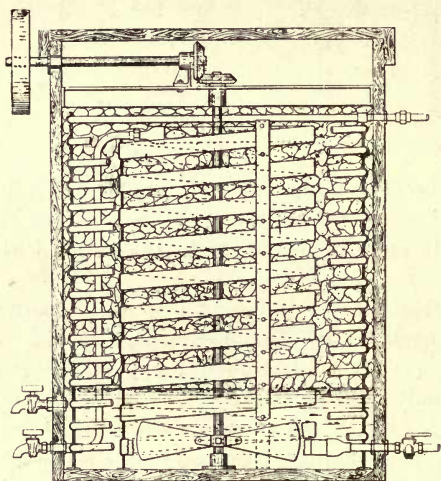

Fig. 317.—Burnand Ice Refrigerating Machine for Dairies.

Paper.—All papers used should be strictly odourless and damp-proof. Tar paper, felt paper, straw paper, rosin-sized paper, and all other common building papers are not suitable and must not be used. Use double thickness of paper in all cases, each layer lapping 2 in. over preceding one. The layers should extend continuously around all corners. All breaks to be carefully covered.

Shavings.—Shavings must be thoroughly dry, free from bark or other dirt.

Shavings from some odourless wood, such as hemlock, spruce, or white wood, to have the preference.

The Burnand ice refrigerating machine, two types of which are shown in Figs. 317 and 318, is especially designed for use in small dairies where ice refrigeration is used. The essential features of the apparatus, shown in Fig. 317, consists in a stout oak tub joining an insulated receptacle and fitted with one or more copper coils according to the capacity required. The space round the copper coil or coils is filled with a freezing mixture, such as finely broken ice and salt, and the temperature of the brine or

water pumped through the coil or coils is thus reduced to the required degree. The brine or water enters the inner coil at the bottom, and from the top is conveyed to an inlet at the bottom of the outer coil. Also, leaving this latter coil at the top, it may be conveyed either to the refrigerating pipes in a cold store, to an ordinary pattern milk cooler, or to other cooling apparatus, and after performing the duty required, returned to a reservoir in order to be again circulated through the refrigerator. To equalise the temperature of the liquefied freezing medium, an agitator, as shown in the drawing, is provided. In this apparatus the circulation of the brine or water through the cooling coils is effected by means of a power-driven pump not shown, and the agitator paddles are driven through the bevel gearing and belt pulley from any convenient source of power.

The small milk cooling apparatus shown in Fig. 318 is intended to be worked by hand power. On the top is a reservoir for the milk to be cooled, which communicates through a stop-cock with a capillary cooler. The cooling liquid is pumped by means of the semi-rotary hand pump shown from the well in the bottom of the tub to the cooler, and after passing through this latter, it is sprayed on the upper part of the broken ice in the tub, and returns to the cold well to be again passed to the cooler, and so on, until the supply of broken ice in the tub is exhausted.

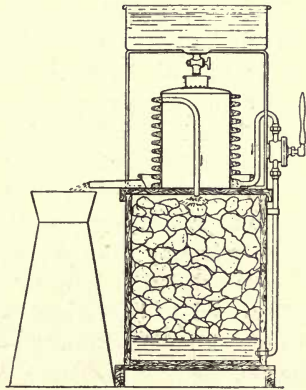

Fig. 318.—Burnand Small Ice Milk Cooling Apparatus.

Dr Samuel Rideal says that very great caution has to be exercised regarding the various temperatures required for different classes of dairy produce as well as care in the methods of preparation and storage prior to refrigeration. The cold storage of milk and butter has been already dealt with in this chapter, and also to some extent in Chapter XV. under the heading of "Proper Methods for Storing and Temperatures for the Cold Storage of Various Articles."

In conclusion it may be observed that in the United States there are a considerable number of persons who advocate the storing of butter at a temperature of 0° Fahr., claiming that butter is undesirably affected by a rise in temperature above that point. On this particular question considerable diversity of opinion seems to

exist. Mr Arthur G. Enock, M.I.M.E., who has had a very extensive experience in the subject of dairy refrigeration, in reply to a query put to him some time ago by the author as to the proper cold storage temperature for butter, said that from his own experience he thought that there can be no hard and fast rule for butter as such, because various butters require different treatments, and again different temperatures, according to the treatment they have received since being made. His experience of fresh Colonial butter, made in Australia, with chilled water by chilled cream from Pasteurised milk, is that the lowest temperature necessary to keep it in first-rate condition for an indefinite period, as far as practical commerce is required, is 20°. But if you get that butter made with all care, and then carried about for a week or ten days without being placed in a cold store, you may want to bring it down to 15° to hold it successfully. Very much the same applies to Irish butter. With all the conditions of manufacture and storage one meets with between Ireland and this country, it is Mr Enock's opinion and experience that 24° is the right temperature, provided the atmosphere is kept fairly dry.

The employment of such a degree as 0° Fahr., or even 14°, is something which, as far as Mr Enock's experience has gone, is unnecessary under ordinary conditions, although possibly special conditions might arise, for example, when butter has to be transmitted by rail for some distance. In the South African cold stores at the ports butter used to be carried down to 10°, and even to 5°, but this was in preparation for transit for three or four days by ordinary railway waggon, slightly insulated, through a very warm country. Such a condition as this, however, does not apply where butter is simply held in storage for in and out use.

As regards the question as to whether butter taken from the dairy, and put into a storage somewhat below freezing, would be found to maintain its quality. Mr Enock thinks that it would be found to do so, but that, at the same time, a good deal depends on how the butter is made. Whether it is washed quite clean, how much it is worked in the butter-worker, and what care is taken in packing it while it is in a chilled condition. For use of refrigeration in artificial butter factories see pages 461 to 464.

CHAPTER XVIII

MANUFACTURING, INDUSTRIAL, AND CONSTRUCTIONAL APPLICATIONS

Chocolate Manufacture—Breweries—Paraffin Works—Artificial Butter Manufactories—Tea Factories—Sugar Factories and Refineries—Blast Furnaces—Wine-Making—Various other Manufacturing and Industrial Applications—Dynamite Factories—Manufactories of Photographic Accessories—Distilleries—Chemical Works—India-rubber Works—Glue Works—Constructional Applications—Tunnelling, Sinking Shafts, Laying Foundations, &c.

INDUSTRIAL AND MANUFACTURING APPLICATIONS.

USES are now made of refrigeration in many manufactures and industries besides that of its more legitimate and important application to the preservation of various provisions of a perishable nature, which latter has been already dealt with so far as space would allow in preceding chapters. All the systems hereinbefore described, with the exceptions of the first, or that wherein the abstraction of heat is effected by the more or less rapid dissolution or liquefaction of a solid, are, to a greater or a less degree, advantageously applicable for this purpose.

Although the preservation of organic substances was the first known and the most obvious use, the successful application of artificial refrigeration to a process of manufacture is somewhat older than that to the preservation of provisions, a Harrison ether machine having been erected at Truman, Hanbury, & Co.'s brewery about 1856, which machine was stated, at a meeting of the Institution of Mechanical Engineers held in 1886,* to be still at work and acting efficiently. A machine of the same type was also said to have been put up by A. C. Kirk in 1861,† who employed it for the extraction of solid paraffin from shale oil.

Another important application of refrigerating machinery is to constructional work, such as the formation of tunnels, the sinking of

* *Proceedings, Institution of Mechanical Engineers*, 1886, p. 246.

† *Ibid.*, p. 231.

shafts, wells, laying of foundations, &c., in loose ground, in quicksand soils, or wherever the amount of water is too great to be pumped or the doing so would be dangerous or inconvenient.

REFRIGERATION IN CHOCOLATE MANUFACTORIES.

The application of a refrigerating machine to the cooling of chocolate during the process of manufacture was first made by J. S. Fry in 1882,* in which year he employed one of Lightfoot's double-expansion horizontal cold-air machines, and was enabled to proceed without interruption throughout the whole year with work that had previously to be suspended during the hot weather. Since that time the use of refrigerating machines in chocolate works has become almost universal. A great saving in chocolate manufacture is likewise effected by the rapid solidification which is rendered possible, and the waste thus avoided; and furthermore, as the chocolate leaves the moulds readily and intact, a considerably fewer number of the latter are required to do the same amount of work.

The essential features to be kept in view in designing and constructing a chocolate cooler may be enumerated as follows:—Uniform cooling of all the goods put into the apparatus; reduction of labour in feeding and taking out the trays containing the chocolate to a minimum; economy of cold air and reduction of the required refrigerating power; and, lastly, simplification of the construction to keep the outlay as low as possible, consistently with obtaining the best results.

The patent chocolate cooler shown in our illustrations Figs. 319 and 320 is made by Messrs A. G. Enock & Co., Ltd., and is claimed by the inventors to embody the above qualities as far as practicable. The cooler consists of an insulated box containing a shaft with a six-sided frame at each end. The two frames are connected by bars upon which the chocolate carriers hang. The shaft is rotated by the hand-wheel outside the cooler and an automatic stop arrests the shaft when the trays come opposite the inlet and outlet slots. It will be seen that each tray of chocolate makes a complete circuit of the cooler, descending from the warmer air at the top, passing through the colder air at the bottom and returning to the top. This method is claimed to be better than revolving the trays horizontally as it will ensure that each tray gets the same amount of cooling.

The trays are fed into the slots shown at the right-hand side of the

* *Proceedings, Institution of Mechanical Engineers*, 1886, p. 236.

cross section, Fig. 320, the cooler shown in the illustration accommodating twelve trays, each measuring 30 by 21 in., and after each carrier has received its two trays the hand-wheel is revolved and the next carrier filled, and so on until all the trays are in place. When the first carrier returns to the top after having made a complete circuit, two fresh trays are put in and the action of putting them in pushes out the other two trays at the left-hand end of the cooler. The work may thus go on continually. And as the cold air naturally falls to the bottom of the cooler, and as the trays are both fed into and discharged from the cooler at the top, there is no loss of cold air. In the pattern of cooler shown in the illustrations flaps are provided for closing the openings through which the trays pass in and out, but in another arrangement these apertures are automatically closed by narrow spring shutters which rise into place after a tray has been put in or pushed out of the carriers.

The insulation consists of 6 in. thick of best silicate cotton or other approved material, the walls of the cooler being lined with white enamelled material ensuring perfect cleanliness and absence of odours. The cooler box is made up in sections, and can be bolted together and set at work by any ordinary carpenter or mechanic. The smaller sizes, however, can be sent out complete in one piece.

The cooler is complete with coils of direct expansion or brine circulating pipes, with counter flanges ready to connect to new or existing refrigerating machinery. The cooler is capable of accommodating trays of any width from 12 to 22 in., which is advantageous, inasmuch as the trays employed by different makers vary considerably in size. The capacities of the machines vary from 1 ton per day of chocolate cooled for the smallest up to 3 tons for the largest-sized machine.

The cold-air machine is well adapted for chocolate cooling, provided only that the air be dry, an achievement claimed by the inventors for the "Arctic" machine, and Messrs Cole have applied it to several chocolate factories with complete success. An advantage of this system is that whilst some forms of refrigerating machines only very partially dry the air, and that inside the room, by deposition of frost on brine pipes, or producing a current of air over brine-wetted surfaces, the "Arctic" cold-air machine acts upon the air before delivering it to the cold-room, or other apparatus, and thus the moisture is deposited outside of and away from the cold-room. There is also the further advantage of there being no brine pipes on which to deposit frost, which may drop on to the chocolate trays, &c., and

requires the provision of special draining gutters, all of which apparatus are frequently more or less imperfect in their action.

A rotary chocolate cooler devised by Mr J. C. Broadbent and Mr J. McRae is claimed to preserve the chocolate from any moisture during the process of becoming solid. This apparatus consists of a series of chambers revolving on a central pivot. The cooler is cylindrical, with a diameter of about 10 ft. and a height of 8 ft. The outside, that is, the case, is constructed of wood, and insulation is secured by the use of silicate cotton. The circular basis of the apparatus is, of course, furnished with a like insulating substance. The upright steel axle is $2\frac{1}{2}$ in. in diameter, and round this revolve the sets of shelves. Every set of shelves is fitted with wooden sides, so that these form in the outer shell six perfectly isolated and refrigerating compartments, the whole being furnished with a toothed revolving gear connected by a hand-wheel situated at the front of the machine. The chambers are provided with an arrangement of spaces for cooling by brine. These have to be put in position when the cooler is to be used, so that none of their number can coincide with the door space of the cooler itself. The shelves of each compartment in the cooler run 2 ft. 9 in. long by 1 ft. 9 in. wide. Of these compartments there are six, with a space of 5 in. between each. The special trays on each shelf are adjusted to carry from 10 to 15 lbs., but where it is required, by a simple change, blocks of any size can be cooled.

The ordinary capacity of an apparatus of the above dimensions is 30 cwt. a day, but a much greater capacity can be had when desired. One of the advantages claimed for this apparatus is that no fastenings are needed. It is constructed on the wedge principle, and hence all the doors close automatically tight. The apparatus is so arranged that when the compartments revolve, and one of them arrives at the door space, and the door is opened, elliptical shutters are automatically operated and cause the sides of the compartment to fit so perfectly that the rest of the cooler remains completely isolated from the air. In point of fact the door may be left open at any time without there being the slightest change in the temperature of any of the other compartments. Then again the top and bottom shutters of each division are absolutely self-acting—automatic, in fact—and thus render the compartment entirely air-tight. Another feature is that the upper and lower ends of the several compartments are so made that, as the shelves rotate, the upper and lower divisions open on the parallel lever system, and directly rotation ceases they shut. A Steinle's thermometer keeps a record of the temperature inside the

cooler and is read on the outside. There is also an ingenious plan by which the contents of the cooler are indicated. The circular top is graduated by six marks numbered from one to six, corresponding to the six compartments. In order to charge and uncharge, the wheel beside the door of the cooler is simply turned until the required number coincides with a fixed pointer in the front. A convenient arrangement is provided for marking the time at which the different compartments are charged, and a timepiece is fixed in the middle of a plate having six dials furnished with movable hands. To facilitate occasional cleaning, the top of the cooler is equipped with a vapour valve, through which an air current can be passed for that purpose.

In another apparatus for treating chocolate an endless travelling band or apron is provided by means of which the chocolate is traversed through a refrigerated compartment.

REFRIGERATION IN BREWERIES.

One of the, if not the most, important of the industrial applications of refrigerating machines is that of cooling water to be used for refrigerating and attemperating purposes in breweries. This is more especially required when the supply of water is derived from a river or other source exposed to the heat of the sun, or from the water mains in large towns, the water from both of these sources usually rising during the summer months to from 65° to 70° Fahr.

Where a plentiful supply of well water at a temperature of from 50° to 54° Fahr. can be obtained, the provision of means for artificial cooling becomes of minor importance for this special purpose, and can be dispensed with.

When, however, the water supply is at a comparatively high temperature, such as that above indicated, it would of course be totally impossible to cool the worts down to the ordinary pitching temperatures of from 57° to 59° Fahr., or to control the fermentation in the tuns or squares with water at such a temperature passing through the attemperators, and, moreover, on the completion of the fermentations it would be likewise quite impracticable to cool the finished beers down to the temperature desirable for racking.

One of the first operations is the refrigerating of the hot beer wort.

The usual practice is to first slightly reduce the temperature of the hot wort by exposing it in the large tank known as the cool-bed or cool-ship, which is generally located on the top of a building and roofed over, the sides being only enclosed by lattice-work, so as to

allow a free circulation of air, and then permit it to flow slowly down over the tubes or coils of a "Baudelot cooler."

The Pontifex-Wood brine refrigerator is also successfully employed for cooling beer worts. This apparatus consists essentially of sets or rows of copper or brass tubes arranged horizontally, and secured at their extremities in return heads. Through these tubes and heads the cold brine from the refrigerator is caused to flow, and the beer worts to be cooled are allowed to trickle over their exterior surfaces.

An ordinary refrigerator for cooling hot beer wort consists of a shallow vat wherein is mounted a continuous tube or pipe, through which the cooling water is forced in a direction opposite to that taken by the wort. The object of thus running the wort in one direction and the water in another is to ensure the delivery end of the wort being exposed to the coldest portion of the stream of water. In another form the wort passes through a coil of pipe arranged in a vat, through which a circulation of cooling water is kept up. A more complicated arrangement is that wherein boxes are arranged to project alternately from opposite sides of a double-walled vertical case; through the latter, and which boxes, the wort is caused to take a zigzag course by suitable check-plates extending centrally into the boxes. The cooling water takes a like sinuous or zigzag course on the exterior of these boxes. A wort or beer-cooler, employed in many large breweries, is a large shallow, covered vat, fitted with a volute formed by a wide strip of metal set on edge between the upper and lower plates or heads, to which it is attached in such a manner as to form a helix with two distinct spaces. Through one of these spaces the refrigerating liquid, or medium, is circulated, suitable inlet and outlet passages being provided, and through the other the wort or beer to be cooled.

Brotherhood's refrigerator consists of a number of long boxes placed side by side or otherwise, each box having a flow and return passage for the cooling water, and copper tubes through which the wort passes. Hollow covers at the ends of the boxes afford communication between one tier of tubes and another.

Mash tuns are likewise constructed in which the vertical shaft carrying the rake or stirrer is formed hollow, as also the arms of the side rake, which latter are perforated with a number of small holes. Through the above-mentioned hollow shaft and perforated arm steam is first passed to boil the wort, and subsequently air, reduced to a low temperature in order to cool or refrigerate it. In a refrigerating or cooling apparatus on a somewhat similar principle, air, previously reduced to a low temperature, is forced into the perforated false

bottom of a vat, from whence it escapes through these holes or perforations and passes up through the wort or beer contained therein.

Numerous other arrangements are also in use in this country and abroad. One of which, of American origin, is as follows:—First the hot wort is delivered into a trough of V shape in transverse section, from the bottom of which it trickles over a series of horizontal pipes arranged in line vertically, and through which the cooling water is passed, the cooled wort being finally collected in a U-shaped trough for delivery to the fermenting tun.

An apparatus which is extensively used in America for cooling or refrigerating hot beer wort, is that known as the “Baudelot cooler.”

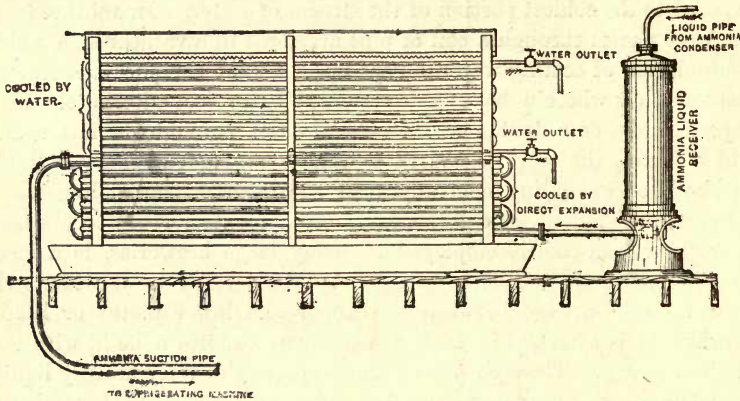

Fig. 321.—“Baudelot Cooler,” with Direct Expansion for Cooling Hot Beer Wort.

This apparatus is constructed for use both with a brine circulation and direct expansion. In the first arrangement, shown in Fig. 321, the upper portion, or half of a set of tubes or coils arranged horizontally, is cooled by the ordinary well or main water, and the lower part or half thereof by mechanical refrigeration on the direct-expansion system. In the second arrangement, shown in Fig. 322, the upper part or half of the pipes or coils is similarly cooled, but the lower portion or half is cooled by brine circulation.

The above Baudelot cooling apparatus is made by the Frick Co., U.S.

Another, and also a very important, use for a refrigerating machine in breweries is that of cooling the air in the fermenting and yeast rooms, an arrangement for which purpose on the brine-circulation

systems is shown in Fig. 323. This cooling is necessary during hot weather, even in cases where an unlimited supply of cold water for refrigerating and attemperating is obtainable, inasmuch as the water can only be applied to the cooling of the beer itself in the fermenting vessels, and not to the head of yeast above. The result of this is that, although the fermenting beers can be well kept under control by the use of the attemperators, the yeast above is frequently found to be going wrong by reason of the excessive temperature of the atmosphere of the room.

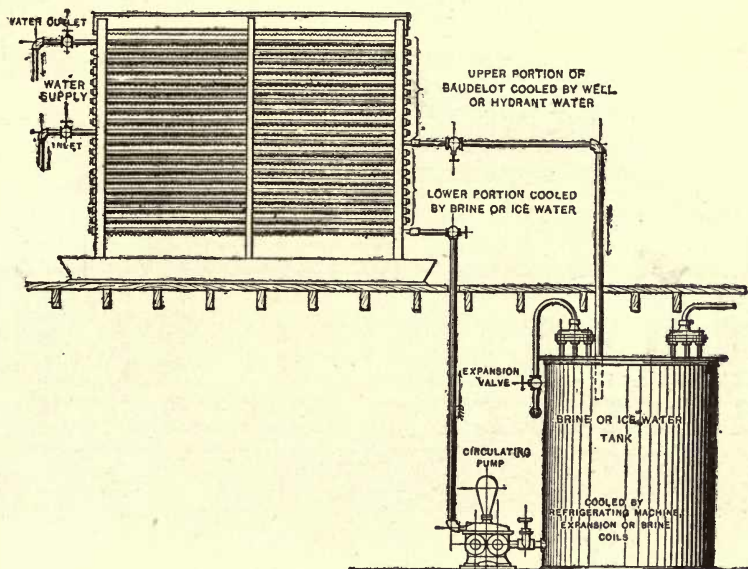

Fig. 322. — "Baudelot Cooler," with Brine Circulation for Cooling Beer Wort.

In employing a refrigerating machine for this purpose, brine reduced in the cooler or refrigerator to about the temperature of the latter, that is from 10° to 20° Fahr., or very much lower if desired, is circulated through rows of pipes B, fixed over the tuns A, or the squares, to be cooled in the fermenting rooms, and also in the yeast rooms, the system of pipes being reduced by the brine to below freezing-point, and the atmosphere of the rooms from contact with the latter to 45° or 50° Fahr., or any other desired point. By this means an October temperature, that is to say, one of 50° Fahr. or less, can be obtained during the hottest summer weather.

Fig. 324 shows an arrangement for cooling a fermenting room on the direct expansion principle, fitted with the De La Vergne patented pipe system, a detailed description of which will be found in a previous chapter.

The speed of the flow of brine in the first arrangement, shown in Fig. 323 through the various circulations, can be regulated at will by means of stop-cocks or valves provided on the several branch mains, and that of the gas or vapour in the second arrangement, shown in Fig. 324, by the expansion valve, and consequently, the temperature of the fermenting rooms can be regulated at will. In simple arrange-

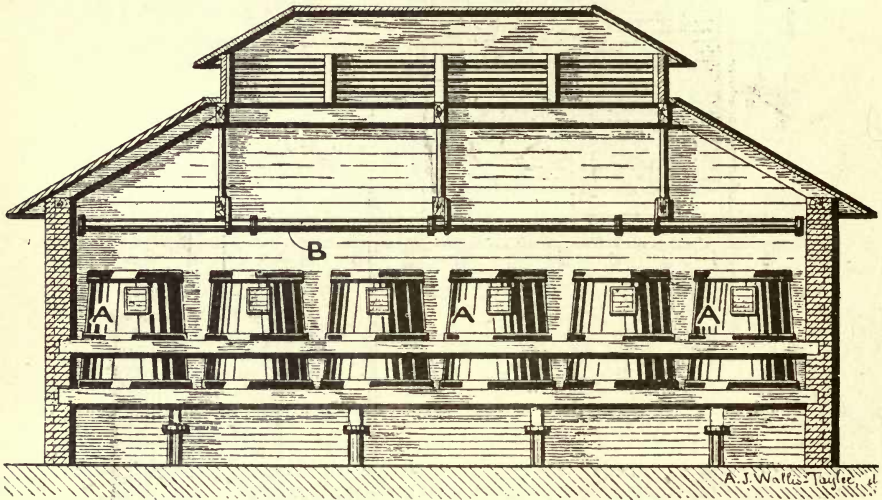

Fig. 323.—Arrangement for Cooling Fermenting and Yeast Rooms in Brewery on the Brine Circulation System.

ments, such as the foregoing, the brine mains B and the direct expansion pipes respectively, cool the entire area of the fermenting room, that is to say, a separate brine circulation (Fig. 323) or coil of vapour pipes (Fig. 324) is run over each row of rounds or tuns, and all are cooled at once. Where a number of large squares have to be cooled, however, a more elaborate arrangement is preferably employed, and the sides and tops of the squares are boxed in or enclosed with partitions formed of light boarding, under which a separate circulation of brine or vapour pipes to each square is fixed. The latter plan enables the temperature of the air over each square

to be regulated separately and independently of the others, and the brine or vapour to be shut off completely from empty squares, thereby lessening the work of the refrigerating machine. It also further economises the work of the latter, inasmuch as only the air directly over each vessel has to be cooled.

In working a refrigerating machine on the brine circulation principle, for these cooling purposes, in a brewery of moderate dimensions, it is usually run during the daytime, and when it is shut off at night, and the fermenting rooms are closed up, the large amount of cold stored up in the brine in the pipes over the fermenting

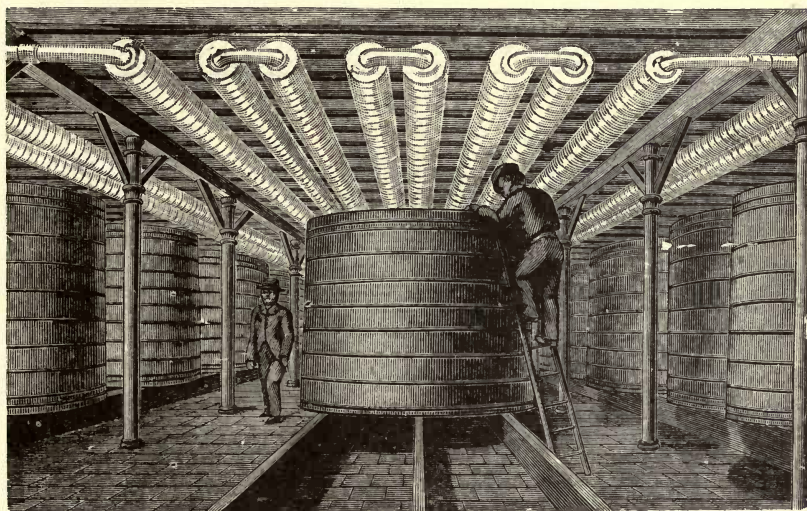

Fig. 324.—Arrangement for Cooling Fermenting Room on Direct Expansion Principle on the De La Vergne System.

vessels, is, as a rule, found to be sufficient to keep the atmosphere of the rooms down to the desired temperature during the night; except, however, in very hot weather, when the machine has usually to be run continuously. In very large breweries also it has generally to be kept working day and night.

In some instances, a refrigerating machine is employed for the combined purposes of cooling water for use in refrigerating and tempering and of cooling the air in the fermenting and yeast rooms. In an arrangement of this description, at the top of the brewery building, or at a sufficient elevation to command the refrigerators and

attemperators, is fixed a suitable ice-water tank, and above this tank a brine refrigerator, which latter may consist of horizontal rows of brass or copper pipes, through which a branch circulation of cold brine from the mains is run, whilst over them the supply water at 60° or 65° Fahr. or other temperature is allowed to trickle or flow slowly. This water is thus reduced by the cold brine within the pipes to about 33° Fahr., or to any other desired temperature, after which it is passed into the ice or cold-water tank, from which it is drawn through pipes as required for refrigerating and attemperating. This arrangement admits, by the simple opening, closing, or regulating of the

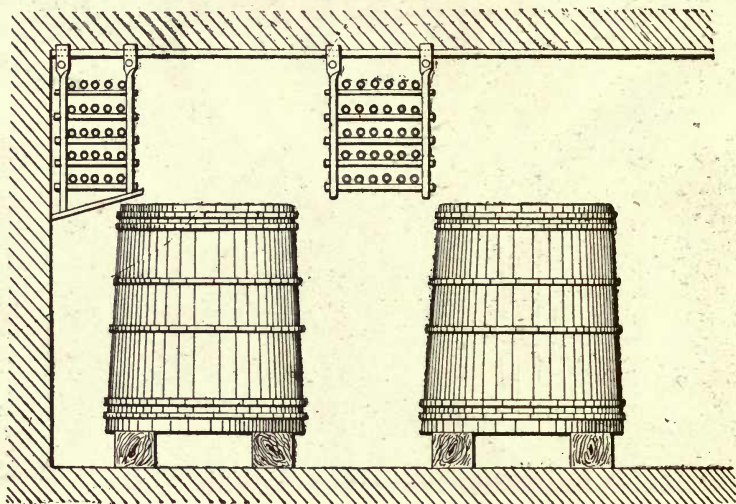

Fig. 325.—Frick Company's Method of Cooling a Fermenting Room in Brewery.

stop-cocks or valves, of the whole or any desired proportion of the power of the machine being applied to the cooling of air, or to the cooling of water, or to both operations at the same time.

Lager beer fermenting rooms and store cellars can be cooled by a plan substantially similar to that shown in Fig. 323, for cooling the air in fermenting and yeast rooms in ordinary breweries. In the case of lager beer, however, where the whole of the fermenting rooms are kept at a temperature of about 42° Fahr. and the stores at about 38° Fahr., a proportionately larger number of brine cooling pipes are required.

Figs. 325, 326, and 327 illustrate a method of cooling a fermenting room, which, as well as the pipe arrangement for vaults shown in Fig. 328, are constructed by the Frick Company, U.S. In the arrangement shown in Fig. 325 the coils are suspended from iron floor-beams, and are located in passage-ways and at the sides of the rooms, by which means any drip into the tubs is avoided, and free access to each tub is admitted of. Figs. 326 and 327 show in side elevation and transverse section the arrangement adopted for suspending flat pipe coils from ceiling on the iron floor beams. Fig. 328 shows in transverse section a pipe arrangement for a vault in a brewery, which will be readily understood from the drawing.

In Figs. 329 and 330 is shown, in side elevation and plan, an automatic attemperation system with a cooling arrangement supplied by the same firm. In this system the ice-water for pumping through

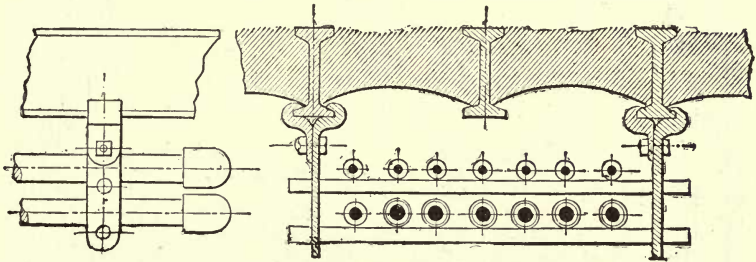

Figs. 326 and 327.—Arrangement for Suspending Flat Pipe Coils from Ceiling on the Iron Floor Beams. Side Elevation and Transverse Section.

the attemperators and regulating the temperature of fermentation is cooled in a cistern or suitable tank, provided with either a direct ammonia expansion or brine coil, supplied by the refrigerating machine, which is on the ammonia compression principle, the sweet or ice-water thus made being forced through the attemperators in the tubs, each or any of which can be shut off or regulated at will, the pressure and amount of cooling water being under automatic control of a self-acting pump and regulator which supplies the attemperators and needs no attention, whether one tub or many be in use.

In Fig. 331 is shown the arrangement of an apparatus for cooling water for refrigerating and attemperating purposes in a brewery by means of an ammonia absorption machine of the Pontifex-Wood type.

In the illustration *H* is the water-service pipe from the company's main or from other source of supply; *i* is the cooled water pipe leading

from the cooler D up to the ice-water tank J, in which the cooled or refrigerated water is stored to be drawn off as may be required for refrigerating or attemperating. A thermometer is fitted on the pipe I at the outlet from the cooler, and a regulating cock or valve on the pipe

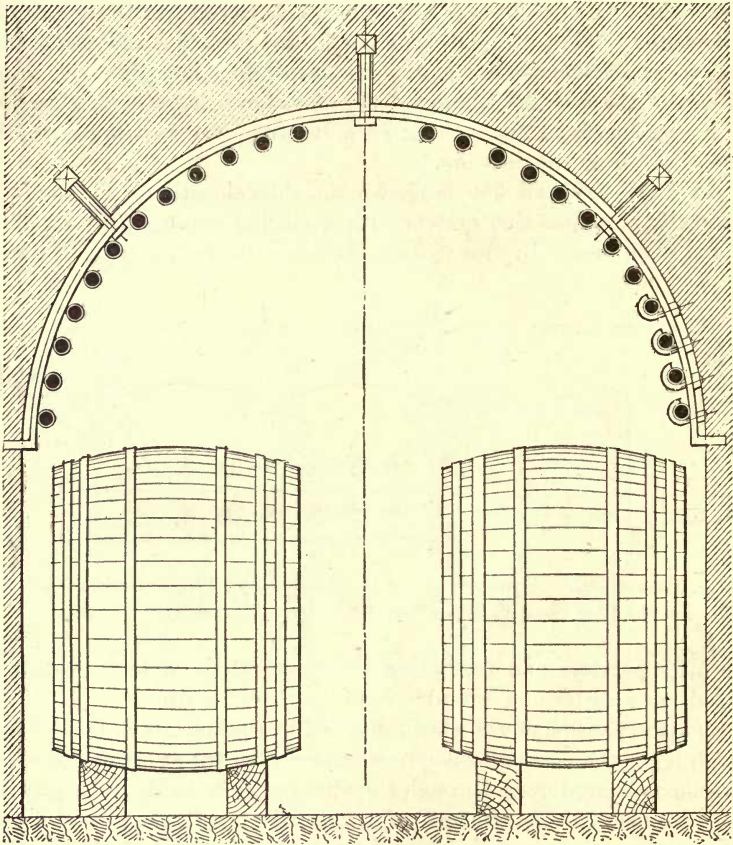
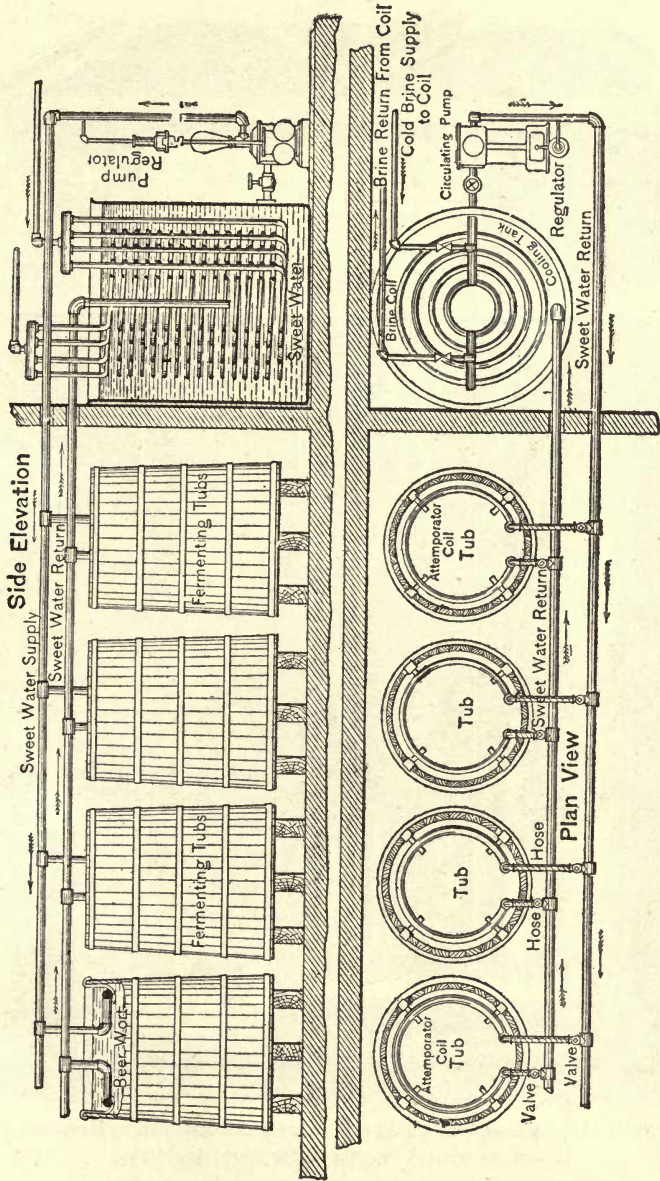

Fig. 328.—Pipe Arrangement for Vault in Brewery. Transverse Section.

H, by which the supply can be so adjusted as to admit of the cooled water being delivered at any predetermined temperature. The water from the supply pipe H is run direct through the coil of the cooler D of the machine (which is placed on the ground floor of the brewery, and sufficiently near the steam boilers to admit of a supply of steam



Figs. 329 and 330.—Automatic Attenuator System and Cooling Arrangement, Frick Company. Side Elevation and Plan.

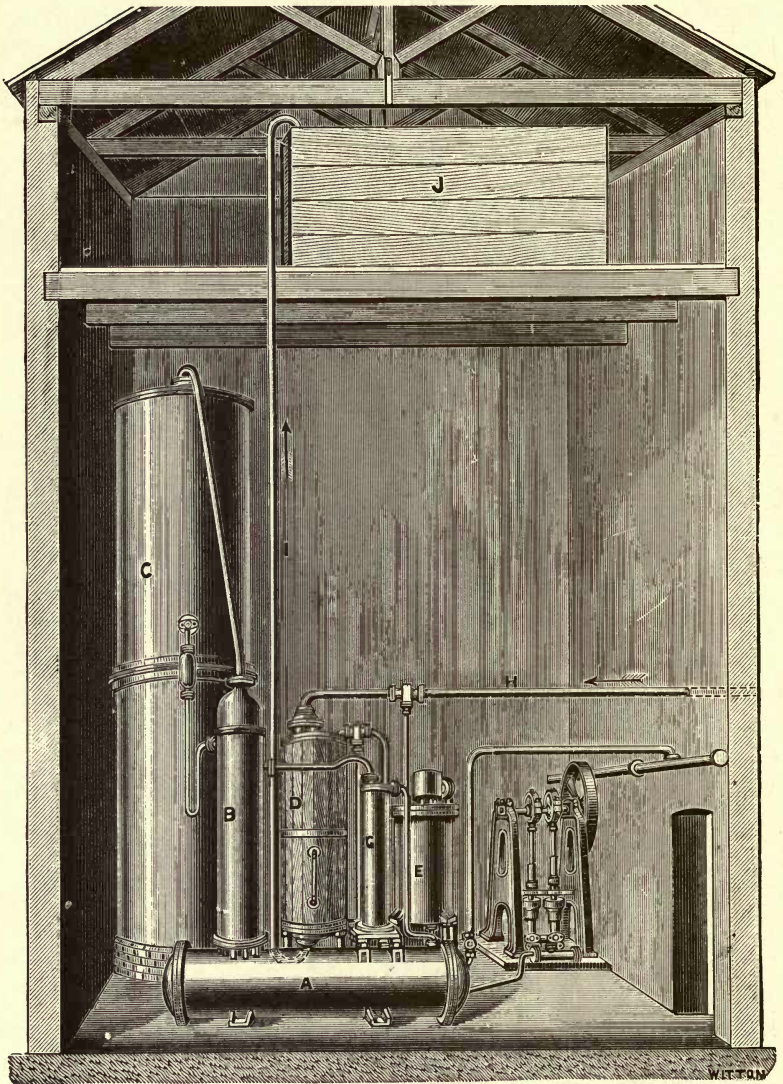

Fig. 331.—Arrangement for Cooling Water for Attenuating Purposes in Breweries with Ammonia Absorption Machine.

being obtained for use in the generator), from whence it passes reduced to a temperature of 45° or 50° Fahr., or to any other desired lower temperature, to the tank J, which is at a sufficient elevation to command the refrigerators and attemperators, and from which, as above-mentioned, it can be drawn off as wanted. The tank J is fitted with a suitable lid or cover, and is preferably constructed of wood, or of iron lagged with wood and sawdust.

A is the condenser, B the separator, C the condenser, D the refrigerator, E is the absorber, and G is the economiser. A full description of the Pontifex-Wood ammonia absorption machine has been already given in a previous chapter.

In working an arrangement of this description the machine is started in the morning sufficiently early to admit of the ice-water tank J being filled up by the time the refrigerators are set to work. The machine is kept in operation until the refrigerating is done, and for a sufficient length of time after to admit of the tank J being filled up again, so as to provide a sufficient supply of ice-water for the use of the attemperators during the night and until the machine is again started next day. It is stated by the makers that when the tank J is properly constructed as regards insulation, it has been constantly found in practice that the rise in temperature of the water is not more than 1° Fahr. during a stoppage of from twelve to twenty-four hours. The ice-water from the tank J is forced through the attemperators, due provision being made for enabling the supply to each of them being suitably regulated, or cut off altogether if desired, independently of the others. The pump for circulating the ice-water through the attemperators should be self-acting and provided with an automatic regulating device, thereby enabling it to act efficiently whether one or all the attemperators be at work.

The results obtained by the use of an arrangement of the description described are, in addition to a marked improvement in the quality of the beer, that there is a complete control over the refrigeration and fermentation, the beer refrigeration can be performed in a very much shorter time, and consequently, the day's work completed sooner, and, lastly, that the waste occasioned by the necessity for passing the greatest possible quantity of the comparatively hot water through the refrigerators and attemperators is obviated. This latter item alone is by no means insignificant, the saving where water companies' water is employed for refrigerating and attemperating being generally more than half. In large breweries where several machines are employed they are kept running continuously day and night.

THE COLD STORAGE OF HOPS.

Refrigeration has been found to be an excellent means for keeping hops from degenerating, and to effect this purpose a dry, dark room, thoroughly well insulated, and maintained at a temperature of from 23° to 34°, is found to be the best. Either artificial or mechanical refrigeration, or ice, may be employed for cooling purposes, the first-mentioned being far superior. Before being placed in the cold storage room or chamber the hops should be thoroughly dried, sulphurised, and properly packed.

Writing on the above subject in *La Revue Générale du Froid*, M. A. Mertus, Brewery Engineer and Professor of Brewing at the University of Louvain, states that hops should be moderately compressed and stored in a temperature maintained constantly between freezing-point and 37° Fahr., with a perfectly dry atmosphere frequently renewed.

Brewers should use hops as soon as possible after leaving cold storage, and they should be kept cool and dry and preferably in the dark. Hops intended for small consumers should be stored in bales of not over 112 lbs. weight, and be delivered as required.

AMOUNT OF PIPING REQUIRED IN BREWERIES.

Without knowledge of all of the elements affecting the cold losses, of course, only general statements can be made. The following data given by Mr F. E. Matthews in an article upon this subject, which appeared in *Power*, New York, will be of interest however:—

The logical way of computing pipe areas, says Mr Matthews, is first to calculate the amount of heat entering through the walls of the cellar, and add to this the amount of heat generated by the fermenting wort. For a given back pressure and known number of hours of operation of the refrigerating machine, it is then a simple matter to calculate the amount of pipe required. The estimate of the pipe area is based on the amount of heat that will pass through the metal of the pipe due to the difference between the temperature of the brine or ammonia on the inside and that of the air on the outside.

The amount of piping depends on the wall area, insulation efficiencies, and differences in temperature. When these factors are not all known, rough rules in the form of ratios may be used. A fermenting room, for example, maintained at a temperature of from 36° to 40° would be piped according to the practice of one large

builder of refrigerating machines, on a ratio of 1 to 14 ; that is, 1 running foot of 2-in. direct-expansion pipe for every 14 cub. ft. of space.

For piping the different cellars in a brewery the following ratios will offer at least a rough guide, it being understood that they may not fit particular cases, and that it is desirable, when it is possible to determine the areas, differences in temperature, and nature of the insulation of each wall, floor, and ceiling, to compute the cold losses through the walls. Then, after determining the ammonia back pressure and temperature, the required number of square feet, and, finally, the number of lineal feet of heat-absorbing pipes may be ascertained.

The table will serve as a guide in laying out the piping for brewery cellars of from 10,000 to 40,000 cub. ft. in size.

RATIO OF PIPING FOR BREWERY CELLARS.

F. E. Matthews in "Power."

| Kind of Service. | Cubic Feet per Foot of Piping, Rooms 1,000 to 4,000 Cubic Feet. | Temperature. |
|----------------------|---|--------------|
| Fermenting - - { | 2-in. direct-expansion pipe 13.5 to 14.5 | } 36° to 40° |
| - - { | 1½-in. brine pipes - - 7.5 ,, 8.5 | |
| Storage cellar - - { | 2-in. direct-expansion pipe 21 ,, 26 | } 32° ,, 34° |
| - - { | 1½-in. brine pipe - - 12 ,, 16 | |
| Chip cellar - - { | 2-in. direct-expansion pipe 24 ,, 30 | } 34° ,, 36° |
| - - { | 1½-in. brine pipe - - 14 ,, 18 | |
| Racking room - - { | 2-in. direct-expansion pipe 12 ,, 15 | } 34° ,, 36° |
| - - { | 1½-in. brine pipe - - 7 ,, 9 | |

The approximate allowance per ton capacity to be made when selecting a machine for refrigerating beer wort is 15 barrels per ton on Baudelot cooler. One thousand gallons of sweet water per ton from 70° to 40°. Climate construction and exposure of buildings to be refrigerated, character of the insulation, management and method of handling work, &c., must of course be considered.

A rough method of obtaining a rough estimate in tons of the amount of refrigeration required in a brewery is to divide the capacity of the brewery in barrels by four.

ICE-MAKING IN BREWERIES.

Another obvious application of refrigerating machines in breweries, though one of secondary importance, is that of making small quantities

of ice, either for use in keeping yeast cool or to send out to public-houses or for private use. This can be very easily accomplished with machines having a brine circulation. If only opaque ice be required, all that is necessary is to place galvanised iron pails, moulds, or cans of the shape of which the blocks of ice are desired, and filled with water in the brine tank, and the water will be frozen in a few hours into solid blocks of ice, which can then be loosened by dipping in warm water and turned out of the cans, the latter having a slight taper to admit of this being more readily performed. When, however,

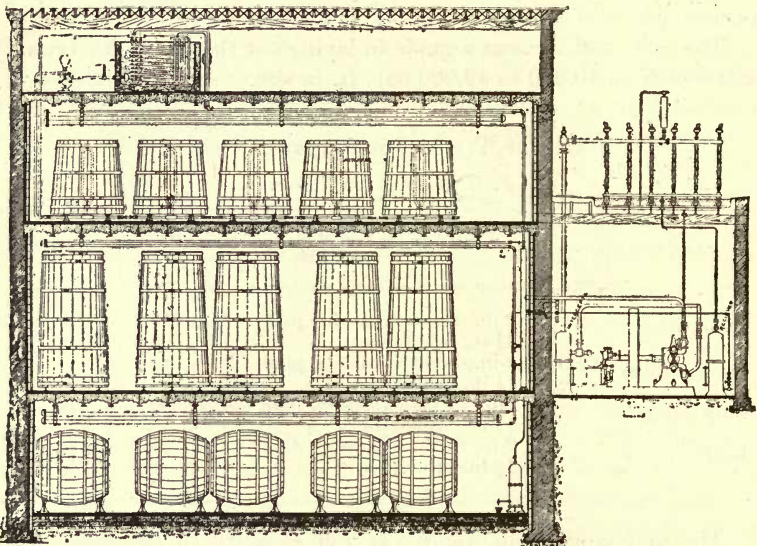

Fig. 332.—Triumph Ice Machine Company, Small Brewery with Refrigerating Machinery working on the Direct Expansion System. Sectional Elevation.

clear, transparent crystal ice is desired, it is necessary to use de-aerated water, or to keep the water in motion whilst freezing, and some special apparatus is consequently required, such as will be found described in the chapter on Ice-making.

In Fig. 332 is illustrated in sectional elevation a complete small brewery fitted with refrigerating machinery on the direct expansion system as designed by the Triumph Ice Machine Company, U.S. This cut gives a good idea of the general arrangement of the plant in such a brewery; for large breweries it will of course differ to a greater or lesser extent, depending upon the size, capacity, &c.

REFRIGERATION IN CANDLE AND PARAFFIN OIL WORKS.

Further important applications of refrigerating machinery to manufacturing purposes are—In candle works, for the extraction of the solid stearine and paraffin; and in paraffin oil works, for enabling refiners to extract in an economical manner in the presses a greater quantity of paraffin than is obtainable in any other manner, and also to obtain a product of a superior quality.

The first type of refrigerating machinery used for the extraction of solid paraffin was, as has been before mentioned, a Harrison ether machine, and the mode of application is described by Dr A. C. Kirk as follows:—

“In 1861, when I applied an ether machine to the cooling of paraffin oil in order to extract the solid paraffin it was, as far as I know, the first application of a refrigerating machine to manufacturing purposes.

“Paraffin oil consists of a mixture of many oils of various specific gravities, and contains in solution many solid paraffins of different melting points, some crystallising from the oil at a low temperature, and some at a comparatively high one. This crystallisable paraffin has to be extracted from the oil, as much to render the oil fluid at all ordinary temperatures as to secure the valuable solid paraffin which is so largely used for candle-making.

“As paraffin and paraffin oil are very bad conductors of heat, it was from the first evident that in cooling it artificially the heat to be removed could not pass through a layer of any considerable thickness but at a very slow rate. In my earlier arrangements pipes, closed at the bottom and opened at top, depended vertically from an iron tube plate, and, by suitable arrangements, a current of cold brine was maintained through these pipes. The pipes hung down into a wooden box, which was filled with paraffin oil, and, after standing a certain time, the oil was cooled and the paraffin was crystallised from its solution in the oil, the whole forming a pretty firm pasty mass. An iron scraper plate fitted these tubes, and being attached to the box and drawn down with it as the box was lowered, forced this frozen paraffin down from between the tubes, and it fell into the bottom of the box.

“This arrangement worked until it was entirely burned down. When it came to be reconstructed, I adopted a more speedy plan. I used a drum, with cold water circulating in it, or it might be cold brine, and as this drum revolved, the lower part of its circumference dipped into a small pan containing the paraffin solution. A coating

adhered to the drum, was cooled as the drum revolved, on the opposite side was scraped off continuously and fell into a tank below. By this means a continuous process was substituted for an intermittent one."

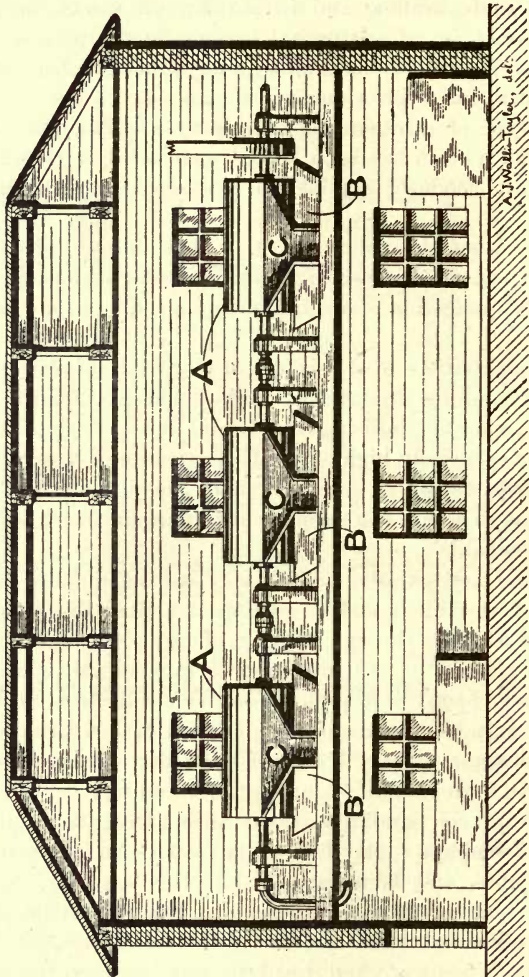

Fig. 333. — Arrangement for the Extraction of Solid Paraffin from Shale Oil. Sectional Elevation.

An ordinary arrangement for the extraction of solid paraffin from shale oil is shown in Fig. 333, wherein A A are the cooling drums or cylinders, B B the troughs or receptacles intended to contain the oil to

be treated, and c c scrapers for removing the partly solidified oil from the drums or cylinders A.

The operation of the apparatus is exceedingly simple, a circulation of brine, first reduced to about 10° or 12° Fahr., or other desired temperature, in the usual manner, is afterwards passed through the set of cooling drums or cylinders A, entering each of the latter at one of the hollow trunnions or gudgeons, and leaving at the other. The lower portions of the drums or cylinders A dip, as shown in the drawing, into the open shallow troughs B, one of which is placed below each drum, and in which the oil to be cooled and treated is placed. The surfaces of the drums or cylinders A during their revolutions are immersed in this oil, and become coated with a thin film of it, which is cooled by the circulation of the cold brine from the machine, and reduced in temperature during the continuance of the revolution, until it is finally removed in a pasty condition by the scrapers c, one of which is arranged to press against the periphery of each of the drums or cylinders. The remaining oil is then drawn away by plunger pumps, and forced through filter presses, which separate the paraffin wax crystals or scales from the oil.

The employment of a refrigerating machine of one type or another in a works engaged in the production of paraffin is, and indeed has been for some years past, deemed indispensable, and but few manufacturers now endeavour to do without it. Indeed, the development of the paraffin industry dates from the time when an ether machine of the Harrison type was first used for this purpose, which, as already mentioned, was in 1861.

REFRIGERATION IN ARTIFICIAL BUTTER FACTORIES.

In the manufacture of artificial butter a variety of ingredients are first melted and amalgamated together at about blood heat in churns, and the resultant mass is then mixed with and run out into ice-cold water contained in open troughs. This sudden application of intense cold crystallises and granulates the artificial butter, which is then skimmed off, and at the same time it also washes out the buttermilk, which otherwise, by its rapid decomposition, would taint the butter.

Primarily, and indeed still to a considerable extent, the means adopted for reducing this water to the requisite temperature is the application of natural ice, which is placed in tanks partially filled with water, and by melting imparts its cold to the latter. This plan, however, is open to several serious objections, amongst which may be mentioned: The excessive cost of the ice and of the necessary labour

for handling it ; the impossibility of thus obtaining as low a temperature as is desirable, the best result being the mean of the two temperatures of the ice and the water ; the non-attainment of a regular temperature continuously ; and, finally, that the natural ice is always more or less

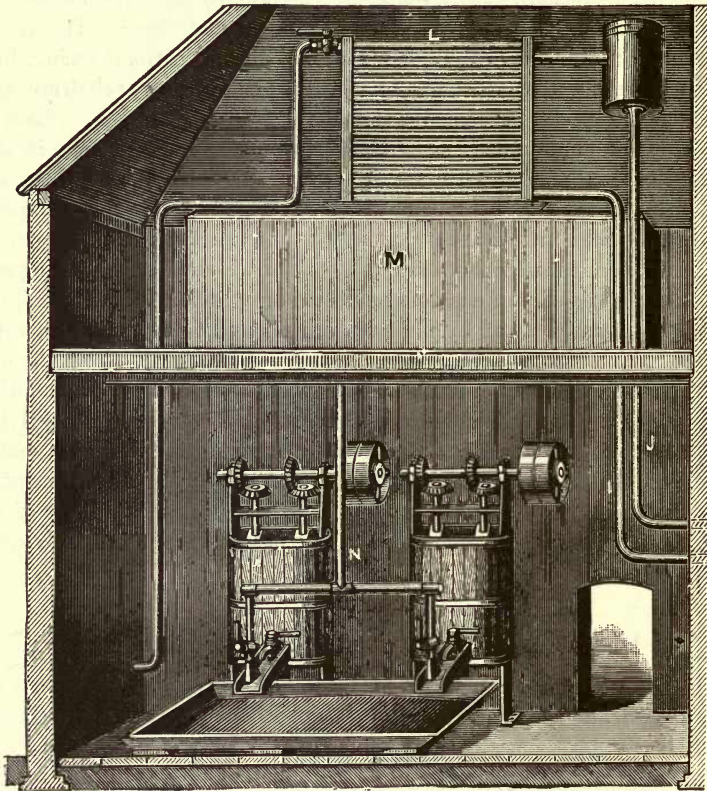

Fig. 334.—Refrigeration Arrangement in an Artificial Butter Factory.
Sectional Elevation.

dirty, and renders the cooled water so also, and consequently soils and spoils the colour and appearance of the artificial butter.

Figs. 334 and 335 illustrate a refrigerating installation in an artificial butter factory.

In the arrangement shown in Fig. 334 a circulation of brine, reduced to a low temperature (about 20° Fahr.) in the evaporator or

refrigerator of a Pontifex-Wood absorption machine, or of a compression machine, is forced by a brine pump through the pipe 1 to the

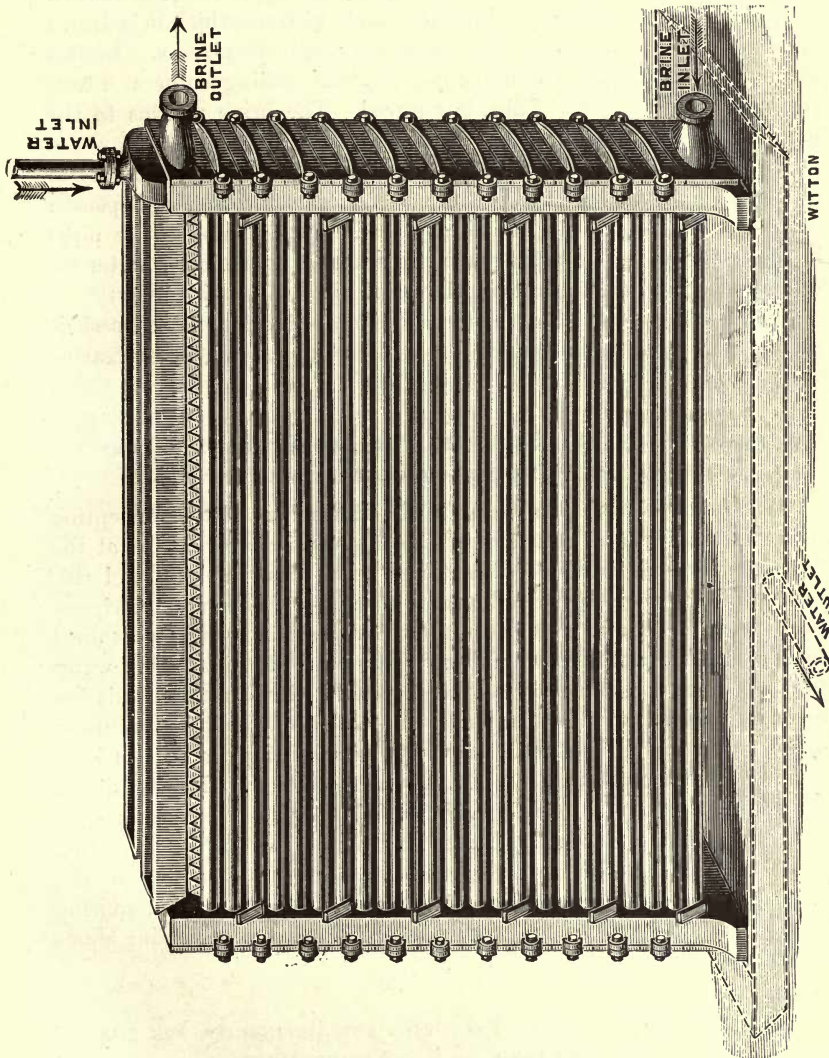

Fig. 335.—Pontifex-Wood Brine Refrigerator.

bottom of the refrigerator L, the construction of which latter is more clearly shown in the enlarged view thereof, Fig. 335. It consists of

sets or rows of horizontally arranged copper or brass tubes, secured at their extremities in return heads, and through which the cold brine from the cooler passes. Over these tubes the supply water is allowed to trickle into the cooled or ice-water tank *M*, from which it is drawn off as required for the use of the churns through the pipes *N*. In this manner a steady and constant supply of clean cooling water at a temperature as low as 32.5° Fahr. is ensured. The brine returns to the pump from the top of the refrigerator *L* through the pipe *J*.

In factories where the practice of using water cooled down only to 39° or 40° Fahr. prevails, the brine refrigerator *L* can be dispensed with and the water to be cooled may be simply run through the pipes in the cooler as in the arrangement in a brewery for cooling water for refrigerating and attemperating, shown in Fig. 331.

For holding artificial butters in cold storage for lengthened periods the temperatures recommended for both butterine and oleomargarine are 20° to 35°.

REFRIGERATION IN TEA FACTORIES FOR REGULATING THE TEMPERATURE OF THE OXIDISING OR FERMENTATION OF TEA.

It is found desirable to maintain the atmosphere of the fermenting rooms in tea factories situated in the low countries or plains at the same temperature as those of factories situated in the hills, and this can be advantageously carried out by means of mechanical refrigeration. A patent for an arrangement of this description has been obtained by Mr H. T. Armitage, of Halton. By means of this process water tanks, cold cloths, fans, &c., can be dispensed with, and the oxidation or fermentation carried on instead in a cold room, the temperature of which need not be reduced below 45°, at which point it has been found that fermentation ceases. A plant erected by Mr Armitage, for the above purpose, consisting of a Schou's patent ammonia compression machine, made by Tuxen & Hammerich, having a cooling capacity sufficient to maintain a room of about 3,800 cub. ft. at 40°, with the temperature outside at about 70° Fahr., and requiring about 2½ H.P. for driving purposes, is found capable of cooling about 250,000 lbs. of made tea per annum.

REFRIGERATION IN SUGAR FACTORIES AND REFINERIES, FOR THE CONCENTRATION OF SACCHARINE JUICES.

Refrigeration is used in sugar factories and refineries for the concentration of saccharine juices and solutions by freezing or con-

gealing the watery particles, which are then removed, leaving the residuum of a greater strength.

A method of concentrating saccharine juices by freezing or congealing and decantation, devised by Mr F. Monté, is thus described in "La Sucriere Indigene et Coloniale." The freezing tank is fitted with two twin coils placed alongside each other, and in which the refrigerating liquid or medium is caused to circulate alternately from the external walls of the tank towards the centre and the reverse, for the purpose of producing layers of ice of equal thickness. The different layers of the liquid are reduced in temperature from the top downwards to the bottom, one after the other, the temperature of the refrigerating agent or medium gradually decreasing. In this manner a larger amount of the juice is frozen or congealed without the formation of an impenetrable mass of ice. The coils of pipe which serve as refrigerating coils for the concentration of the saccharine juices, are subsequently employed to cool the refrigerating liquid or medium itself.

The freezing or congealing tank comprises a vessel having separate coils of pipe placed at different heights therein, the circulations being arranged to take place, as already mentioned, from the exterior towards the centre. A battery or set of these tanks are connected up in series so that the freezing or congealing and the concentration can be carried out uninterruptedly, and that the ice formed and remaining after the removal of the concentrated liquid may subsequently be used to reduce the temperature of the refrigerating liquid or medium without there being any necessity for the removal of the ice.

REFRIGERATION IN BLAST FURNACES FOR DESICCATING AIR AND PRODUCING A DRY BLAST.

Refrigerating machinery is becoming largely used for desiccating the air for use in blast furnaces, and producing a dry blast. To remove the moisture from the air the latter is reduced in a suitable cooler to a temperature below dew point. The surplus moisture in the air is precipitated upon cold surfaces, and the air leaves the cooler nearly saturated, and at a comparatively low temperature. The percentage of saturation remains constant so long as the temperature is the same. In the case of coolers of the "dry" type working at moderately low temperatures, a portion of the moisture precipitated is deposited upon surfaces in a liquid state, and can be drained off. The

remaining moisture is precipitated in the form of snow, and must be removed from the snow boxes from time to time. In coolers of the so-called "wet" type, the air is brought into contact with an uncealable brine bath, which absorbs the surplus moisture. The brine becomes weak from dilution, and has to be periodically reconcentrated either by the addition of fresh salt or by evaporation. An objection to the "wet" type of apparatus is the possibility of brine being carried away in a finely divided state with the currents of cold air.

The advantages of desiccated air are as follows:—A reduction of about 15 per cent. in the consumption of coke, and an increase of from 10 per cent. upwards in the production of iron, according to the nature of the furnace, character of the ore, and other conditions. The furnace is more regular and uniform in its operation, and will hold the zone of fusion more steadily nearer the tuyeres. The life of the furnace lining is also lengthened, by 20 to 30 per cent., according to the working conditions. The use of desiccated air enables a much higher heat temperature to be employed, and also ensures an economy of from 5 to 10 per cent. in the limestone used for fluxing purposes. There is also found to be a marked regularity in the silicon and sulphur content of the pig iron, which is a very important point, and also a considerable reduction in the flue dust owing to the concentration of the heat at the tuyere zones, which causes regular operation, and prevents slipping or scaffolding in the furnace. The flue dust may be reduced as much as 50 per cent. by careful working. The use of desiccated air also gives greater economy in the working of the blowing engines, the speed of which may be reduced as much as 15 per cent.

Figs. 336 and 337 show a large ammonia (NH_3) plant on the Haslam system, erected at the Spring Vale Furnaces, Wolverhampton, belonging to Messrs Alfred Hickman, Ltd. The installation is capable of desiccating 100,000 cub. ft. of air per minute, entering the batteries at 90° Fahr., and reducing same to 20° Fahr., with a saturation of 1.3 grains of vapour per cubic foot. This apparatus, which has been in operation for some time, is found to give excellent results, and, if required, a lower temperature than 20° can be obtained. The desiccated air is delivered to five furnaces, and also to the steel works for use in the converters.

The installation comprises six duplex ammonia compressors driven by rope gearing from electric motors. The ammonia condensers are of the Haslam type, interlaced and without joints welded by electricity. The condensers are constructed to work with high temperature con-

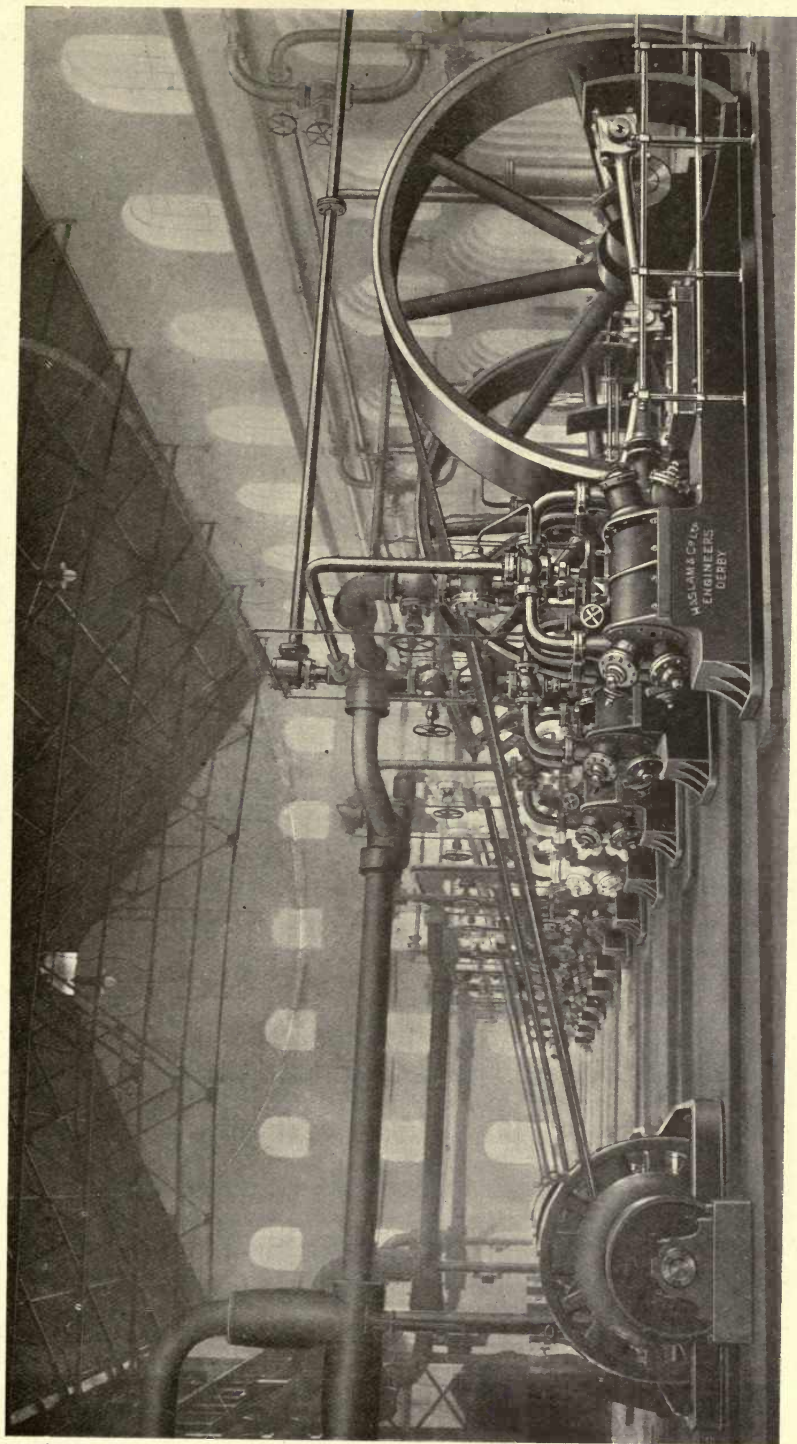

Fig. 336.—Installation of Refrigerating Machinery (Haslam Type) for Desiccating 100,000 cub. ft. of air per minute for use in Blast Furnaces. Perspective View.

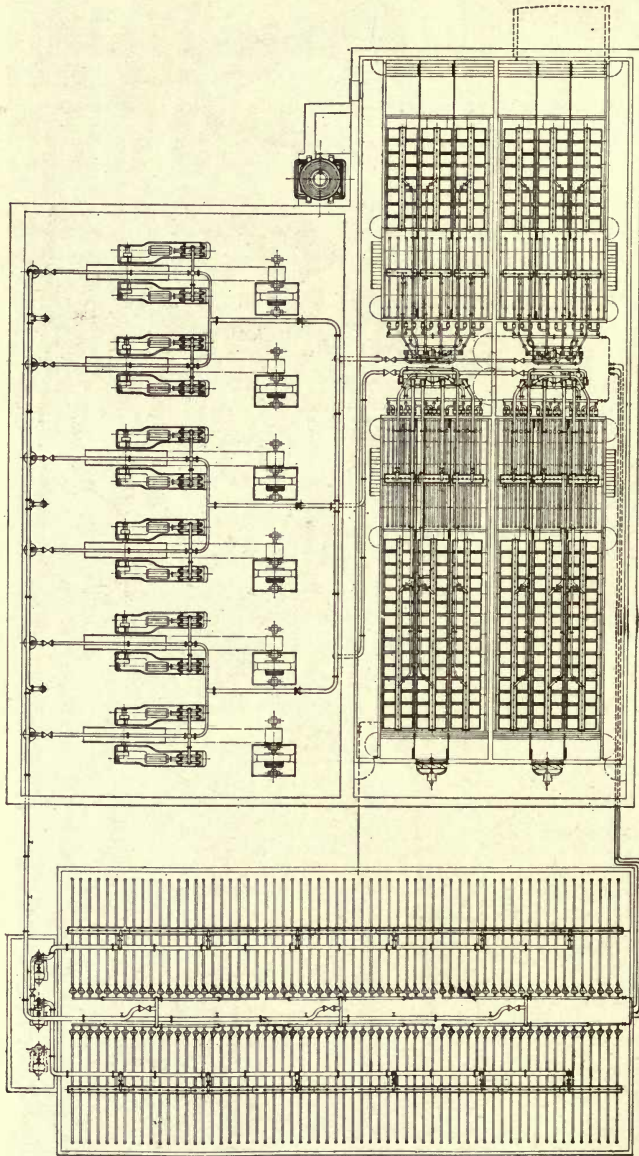

Fig. 337.—Installation of Refrigerating Machinery (Haslam Type) for Desiccating 100,000 cub. ft. of Air per Minute for Use in Blast Furnaces Plan View.

densing water, and the water pumps are driven by electric motors. The cooling of the air is effected by a Haslam patent air-cooling battery which consists of galvanised corrugated steel plates and direct expansion cooling pipes (see pages 294, 295). This battery is divided up into two sections, one for cooling water and the other for cooling brine. In the first section the air is cooled from 90° down to from 36° to 38°, and here the greater part of the aqueous vapour is extracted. The air then enters the second section at a temperature of from 36° to 38°, and is cooled by brine to 20°, or lower if required, and the remainder of the vapour extracted. The advantage of this arrangement is that the air deposits the great part of its moisture in the first cooler, and only a relatively small amount is extracted in the second cooler. A special brine concentrating apparatus is provided, so that any water accumulating in the brine can be evaporated, which admits of the brine being kept at a regular specific gravity.

REFRIGERATION IN WINE MAKING.

The following is an abstract of an interesting article on the use of refrigeration in wine making which appeared in the *Revue Générale du Froid*, Paris.

Substances contained in saturation in the must of grapes become indissoluble when the temperature is reduced, and 2 to 3 grammes of cream of tartar have been in this manner obtained per litre of must of Burgundy wines. The gums, mucilages, and albuminous matters being acted on at the same time.

Precipitations of mineral and organic substances create an inductive force acting on the matters in suspension, the deposit and the clear liquid becoming separated in respectively varying volumes, and low temperatures having an intense defecating action. Cold augments the supersaturation of the mineral substances of the must, which has a great affinity for them, whilst the combinations of air and must are the slower the lower the temperature. This slowness of oxidation is an important feature.

The action of cold may be helped by that of heat. Clear clarified must heated to 60° forms a second coagulation, the precipitation of which is aided by cold. The two actions of refrigeration and Pasteurisation may be thus combined, and a clear must deprived of many substances destined to be afterwards precipitated be obtained.

In order to multiply the ferments, if the Pasteurisers are not dispensed with it is necessary to clarify and relieve the must of the

greater portion of its germs. The best method consists in lowering the temperature to 4° or 5° or even to 0° if possible, with the addition of from 3 grms. to 5 grms. of liquid sulphurous acid per hectolitre of must. The defecation of cold has generally the result of taking from wine any earthy taste.

Gatherings of grapes changed or decomposed are greatly benefited by refrigeration of the must before fermentation. The oxidising substances which impregnate mucilages are precipitated in the lees with a portion of the hurtful particles, likely to impart disagreeable flavours.

The growers would find it advantageous to submit the must of white wines to the action of cold on coming from the press, until it turns limpid. Fermentation after drawing off clear should be allowed, and the ferments added will act more efficiently.

White wines ferment in large vats at temperatures exceeding 32° to 35°. A low temperature preserves the aroma produced by the ferments, and refrigeration by means of water is, as a rule, insufficient in practice for the maintenance of a suitable temperature.

On leaving the fermenting vats, white and red wines throw down important deposits. The wine deposits its gross lees during the first month. At the end of six months the wine has made a series of deposits and assumes a limpid nature. The wine-grower dares not hasten young wines. With the help of refrigeration, however, a more complete and regular clarification can be obtained than that produced by six months of rest. Besides which, the lees or dregs are reduced to a minimum, and are heavy and concrete. The diminution of lees, especially in the case of raw wines, repays to a great extent the cost of refrigeration. The wines thus freed may be immediately used, and under this head there is a saving in cellarage for the producer. In the year 1860 the use of cold for the congealing and concentration of wines was predicted by Vergnette Lamothe in Burgundy.

As large quantities have to be cooled, it is advisable to take measures to recover the cold, and the cooled wine may be used as a source of cold by means of temperature exchangers.

The must is drunk in France under the name of unfermented wine, "vin bourru," "macadam," "vin doux." Towns like Paris, Lyons, and St Etienne, receive entire train loads of must from the south or special centres, such as Bergerac. In South America must is consumed after heating it over an open fire to impart keeping qualities and to give it a special flavour. Up to the present the practice has been to forward in tuns from Vignoble the must coming from the press. The

tuns are first either strongly fumigated, or treated with bisulphate of potash. Refrigeration is, however, the best means for transporting must to a distance. Must cleansed with 10 grms. of liquid sulphurous acid per hectolitre, Pasteurised in the same way as wine and cooled to 8° , may be transported to any distance in waggons properly arranged.

The concentration of wine by means of artificial cold had already been suggested by Baudoin and Schribaux; and M. Pacottet again in 1895 arrived at the same conclusions with respect to the problem: (1) The freezing point is lowered in correspondence to the alcoholic contents, a wine having 7 per cent. of alcohol commencing to freeze at -2° with formation of little crystals of ice; at 11 per cent. of alcohol the freezing temperatures falls to -5° and -6° . Concentration by cold therefore calls for very low temperatures, and is consequently onerous. (2) If the crystals of ice be separated from the rest of the wine, drained, and then submitted to an energetic whirling, they will be found to retain quantities of alcohol often exceeding 1 per cent. and also colouring matters. (3) Wine concentrated by congelation has a turbid appearance. After a certain period of repose it throws down an abundant deposit formed chiefly of organic matters, of tartar, and of colouring matters. If the concentration be carried to any length, the wine deteriorates with considerable rapidity, and assumes at the end of a few months the yellow tint characteristic of stale wines. To sum up, concentration by freezing entails considerable losses in alcohol, of colouring materials, and of tartar. The concentration of musts by means of cold is not yet developed on an industrial basis. The operation calls for special plant, and has to compete with concentration in vacuum at 40° to 44° . In a country such as the Argentine, however, where fuel is scarce and water power cheap, cold might be used economically as a concentrating agent. Its use affords the advantage of producing musts which are less acid than those produced with heat as the agent.

VARIOUS OTHER MANUFACTURING AND INDUSTRIAL APPLICATIONS.

Amongst the numerous other manufacturing and industrial applications of refrigerating machinery, mention may be made of the following:—

In dynamite factories for maintaining the dynamite at a low temperature during the process of nitrating.

In manufactories of photographic accessories for cooling the gelatine dry plates.

In soda-water works for cooling soda or mineral waters before bottling.

In chemical works for the reduction of mother liquors at low temperatures, thus hastening crystallisation, and augmenting the amount of crystals produced, as well as reducing the cost of production. In addition, however, to substances the crystallisation whereof is facilitated by cold, it can be also advantageously employed for the congelation of various chemicals, and for other purposes.

In india-rubber works for the curing and hardening of blocks of india-rubber, thereby facilitating the cutting of same into sheets for the manufacture of various elastic articles, the material in that state admitting of it being worked up in a much superior manner, and, moreover, at a far lower cost. In glue works for drying the gelatine, and so admitting of the use of less concentrated solutions. And also in numerous other industries, in which it would be impracticable to carry out many of the manufacturing processes in the summer months without the employment of some artificial means for cooling.

For the purification of gas intended for the inflation of balloons by the removal of tarry matter, &c., therefrom, and also for drying the gas by the elimination of the greater portion of the aqueous vapour present in ordinary coal gas as usually commercially manufactured, and in this manner greatly increasing its efficiency for the purpose in question. This method has been proposed by Mr C. Lambert.

In tropical and other warm climates for cooling the atmosphere of hospitals and public buildings.

For the regulation of plant growth by retarding the growth of bulbs and flowering plants to produce blossoms at any time of the year desired, and to fruit trees, so as to enable fruit to be obtained at any season.

In laundries for effecting the white bleaching of clothes, and for drying them, the latter operation being performed by means of a condensing plate.

For freezing bait in northern waters. At the present time a cold store of considerable size is being erected in the Westmanna Islands intended for the preservation of herrings for use as bait in the Iceland line fishing.

For the preservation of furs, and various fabrics such as carpets, rugs, silks, tapestries, and upholstered furniture, from the ravages of moths and beetles, and in the case of silks to prevent them from losing weight and to preserve their gloss or lustre. Furs should be kept in

dark chambers at a temperature of 0° C. ; small articles in cases with layers of paper between, larger ones hung independently.

For cooling the holds of vessels carrying live cattle, in which manner a uniform temperature of about 70° Fahr. can be maintained throughout the entire voyage (instead of its rising to over 100° as it otherwise would), thus entirely obviating the heavy losses of cattle usually experienced from the high temperature and bad ventilation. It might also be advantageously applied, on large passenger steamers, to cool and ventilate the saloons and state-rooms, as also the engine-rooms, &c., when in hot latitudes.

And finally, for producing artificial surfaces of ice in inclosed places, so as to provide skating rinks upon which this pastime may be enjoyed during the mildest winters, or at any season of the year. Such an installation was erected some years ago at the Niagara Hall, London, of which the following is a brief description :—

The plant consists of ammonia compression machines of the De La Vergne type, the ice-making capacity of which is of 12 tons per day each. The rink itself, when in everyday use, requires the expenditure of a refrigerating power equal to that consumed in the manufacture of 8 tons of ice per day, and the balance of power, which is considerable, is employed in the manufacture of block ice, and in maintaining the cold storage chambers in connection with the rink at the required temperature.

The congelation or freezing of the water to form the ice surface of the rink is effected by a network of pipes which are laid upon the floor of the rink, and through which brine, reduced to a sufficiently low temperature in the refrigerator of the machine, is kept in constant circulation by means of a suitable brine pump. The non-congealable liquid or brine employed in this instance is a strong solution of calcium chloride.

The operation of the ammonia compression machines employed for this purpose differs in no way from the description already given when dealing with that type of machine.

CONSTRUCTIONAL APPLICATIONS.

For the freezing of loose ground in quicksand soils, in order to facilitate sinking colliery shafts, well-sinking, tunnelling, or putting in foundations, wherever the amount of water is too great to be pumped or in cases where the removal thereof would damage existing foundations, to avoid the necessity for expensive underpinning, &c. This may be effected either by means of ammonia or cold-air machines.

In the case of a quicksand in a well, a coil of pipes, of a somewhat larger diameter than the lining of the well, is usually sunk into the quicksand, and the latter frozen by a circulation of cold brine through the coil. The necessary excavation can then be proceeded with, and as soon as the lining is put in, the circulation of brine is stopped and the coil withdrawn.

TUNNELLING.

During the construction of a tunnel for foot-passengers through a hill in Stockholm this method was employed for driving the tunnel through about 80 ft. of loose ground, consisting of gravel mixed with clay and water, which possessed so little cohesion as to render the ordinary method of excavation impossible. The refrigerator employed was a cold-air machine of the Lightfoot type, capable of delivering 25,000 cub. ft. of air per hour, and the arrangement consisted in forming the innermost end of the tunnel into a freezing chamber by means of a partition wall made of a double layer of wood filled in between with charcoal. After the refrigerator was run continuously for sixty hours the gravel was frozen into a hard mass to a depth varying from 5 ft. near the bottom of the tunnel to 1 ft. near the top. The work was proceeded with in 5-ft. lengths, the excavation commencing at the top, and a temporary iron wall of plates 12 in. square was built up against the face from the top downwards as the cutting away of the gravel was proceeded with; the arching of the tunnel was completed as quickly as possible close up to this temporary iron wall while the ground was still frozen. After being fairly started it was found sufficient to run the cold-air machine on the average from ten to twelve hours every night except after heavy rains, when much water percolated through the gravel. After two 5-ft. lengths had been excavated the partition was moved forward. The daily progress whilst employing the freezing process was on an average about 1 ft.

A full description of the construction of this tunnel is given in the *Engineer* of 9th April 1886. And in the issue of 30th November 1883 of the same journal, will be found an interesting account of the Poetsch method of sinking colliery shafts by freezing the soil by means of an arrangement consisting of a series of vertical iron pipes placed in a circle.

SINKING SHAFTS.

A very interesting account of the more recent applications of the Poetsch process in France has also been given in a paper upon the

use of freezing machinery for sinking through water-bearing strata by F. Schmidt,* of which an abstract is subjoined.

The Poetsch process was first employed in the Houssu coalfields of Hainault in 1885, having been introduced into France at a later date, viz., 1890, and since extensively employed for sinking pits through the Tertiary and Cretaceous strata above the coal measures at Vendin-Sens, Dourges, Courrières, Vicq-Anzin, and Flines-lez-Raches, the pits being respectively 82 and 84, 47, 45, 102 and 102, and 70 m. in depth.

The latter was the most difficult undertaking. The permeable strata to be got through were 70 m., blue marls affording a bearing for tubing at 72 to 79 m.; the Tertiary sands and clays were 25 m. and the chalk about 50 m. in thickness. At the junction of these formations a heavy sheet of water was encountered, which gave from a single bore-hole a flow of 1,200 cub. m., which rose to 2 m. above the surface; a second one in the lower portion of the chalk between 65 and 70 m. also overflowed. Two brick towers were constructed round the mouth of the pit—viz., an inner one of 6 m. and an outer one of 11 m. in diameter, and rising the one 1·6 m. and the other 2·6 m. above the level of the surface—with the object of arresting these feeders, but were found to be ineffectual and incapable of maintaining the water level constant by reason of a lateral flow joined to subsidence which was set up in the overlying strata of sand, the arresting of which necessitated the sinking of a special bore-hole so as to trap the spring at a distance of 25 m. eastward from the pit, by which means a steady head of 1·6 m. of water was got in the towers, and the freezing operation could be commenced.

The freezing circuits were twenty-two in number, contained in bore-holes 75 m. deep, one of which was located in the centre of the pit, which was 4·2 m. in diameter, the remaining twenty-one being arranged in a ring 6 m. in diameter. An ammonia-compression machine of the Fixary type was used for the production of the necessary cold; it was driven by a 500 × 900 mm. single-cylinder engine, making eighty revolutions per minute, and capable of producing cold equal to 1 ton of ice made per hour.

In thirty-eight days from the 1st September 1894, upon which date the freezing machine was started, the ice-wall was completed, and the sinking commenced on the 25th October, the relief or special bore-hole being stopped for good on the 5th November. At the upper strata the ground was broken up by means of picks and wedges, but at a lower level blasting by means of compressed powder was employed.

* *Bulletin de la Société de l'Industrie Minérale*, vol. ix., 1895, pp. 273-416.

The central tube was disused and removed as the sinking progressed. When a depth of 14·8 m. was reached two oak seating rings, the one 22 × 24 cm. and the other 22 cm. square, were secured in position for the first line of tubbing, which was composed of segments of oak 16 cm. to a height of 2·6 m. above the surface level, with a 16 cm. backing of concrete increased to 70 cm. near the surface. A second seating with curbs of 22 × 24 cm. and 22 × 20 cm. was fixed at 25·93 m., and a third at 43·82 m., which latter had three seating rings respectively, of 22 × 28 cm., 22 × 24 cm., and 22 × 22 cm. in section, the tubbing rings being of 18 cm., with the same thickness of concrete behind. By April 1895 the pit was sunk to a depth of 70 m., and on the 1st May the building of the tubbing was completed. Light was provided by incandescent electric lamps supplied with electricity from a dynamo situated in the same building as the freezing machine.

The cost of sinking in frozen ground per meter was as follows:—

| | | | | | | | |
|-------------------------|---|---|---|---|---|---|------------------|
| Freezing | - | - | - | - | - | - | Francs. |
| Sinking | - | - | - | - | - | - | 1,550 |
| Tubbing | - | - | - | - | - | - | 150 |
| Concreting and sundries | - | - | - | - | - | - | 650 |
| | | | | | | | 50 |
| | | | | | | | 2,400 per metre. |

The Poetsch method of sinking has been also lately successfully employed at the coal-field of Ligny-les-Aire in a sinking through a permeable covering of about 86 m., and in the repair of the cylinder pits of the Fontinette Canal lift. These pits, which were of 4 m. in diameter, were sunk by compressed air and tubbed with cast iron between 1883 and 1887. In 1893, however, owing to an irregular subsidence of the ground, they became leaky, and it was decided to replace the iron lining by one of brickwork of 80 cm. in thickness, thus reducing the diameter from the original 4 m. to 3·7 m., with a considerable increase in the bottom bearing of the press, which was to consist of a cylindrical block of brickwork 5·307 m. in diameter and 2 m. in height. In the carrying out of these repairs it was decided to adopt the freezing process in preference to using compressed air, so as to avoid any chance of disturbing the ground, and thus causing damage to the neighbouring buildings.

The work was commenced at the right-hand press, the boat-cradle being secured at its highest level by means of two supporting girders of 40 m. in depth; the piston was disconnected, and twenty bore-holes arranged on a circle of 6·307 m. in diameter, or 99 cm. apart,

and one placed centrally, were provided for freezing. These bore-holes were about 2 m. deeper than the bottom of the new foundation, and lined with tubes of 150 mm. in bore and of 5 mm. in thickness, formed of steel. The freezing tubes were likewise of steel and 125 mm. in diameter, and the inside brine supply pipes of iron and 33 mm. in diameter; the collecting rings were of 100 mm. bore by 5.050 m. diameter on the admission, and 5.7 m. diameter on the return circuit.

Mr Schmidt does not think that the methods of working proposed by Mr Gobert and Mr Koch are likely to afford as favourable results as are obtainable by the original method. The first of these gentlemen proposes to volatise the liquefied ammonia in the freezing circuits; and the latter depends entirely upon gaseous expansion.

The paper also contains descriptions of the combined method of freezing and fire-setting in frozen ground used for prospecting for gold in the alluvial deposits of the Siberian rivers during the winter.

The following extracts are taken from an account of Mr Gobert's system * given in "The Colliery Manager's Handbook":—

This is a modification of the Poetsch congelation method, and is specially applicable to the sinking of shafts through shifting sands and water-bearing strata.

Fig. 338 is a vertical section and Fig. 339 a plan showing the refrigerating plant and the shaft to be sunk, the two being as near each other as possible, and the shaft being lightly roofed over as a protection from the weather. The power of the steam engine required varies with the diameter and depth of the shaft to be sunk, and need not exceed 40 H.P. unless the shaft is deep. The steam engine and compressor are placed horizontally side by side and connected to the same shaft, with a fly-wheel and pulley for belting between them.

Liquid ammonia is forced by the compressor through the series of wrought-iron tubes of the condenser, first to the reservoir, which acts as a kind of governor, and then by the lower of the two pipes seen in the vertical section to the system of congelation tubes round the shaft. Great heat results from compressing the gaseous into liquid ammonia, and in order to abstract it, the condensers have a relatively large surface, and cold water is caused to circulate freely round them. This water is kept in a state of agitation by means of the small water wheels with floats, shown in the drawings, driven by belts off the pulley on the main shaft.

* For further description and illustration of the system see "The Colliery Manager's Handbook," by Caleb Pamely, M.E., published by Crosby Lockwood & Son, London.

The machinery, by means of the upper of the two pipes seen in the vertical section, exhausts gaseous ammonia from the congelation tubes, sunk vertically beneath the surface of the earth round the site

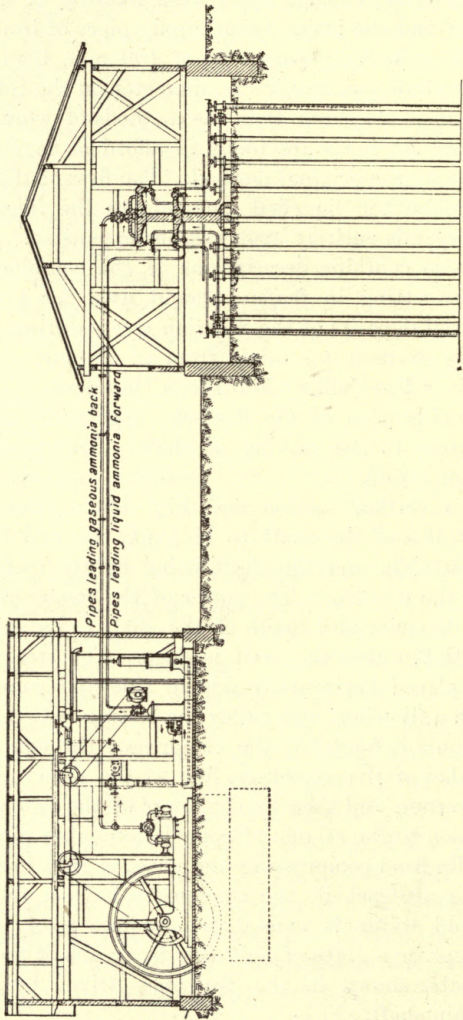

Fig. 338.—Gobert Congelation Method of Sinking Shafts. Vertical Section.

of the shaft, and forces it, condensed into a liquid form, first through the apparatus for separating the oil (see Fig. 339), and then into the condenser.

The compressor piston is freely lubricated with mineral oil, and some of the ammonia comes into contact with and is absorbed by it. The mixture might choke the tubes of the condensers, and pos-

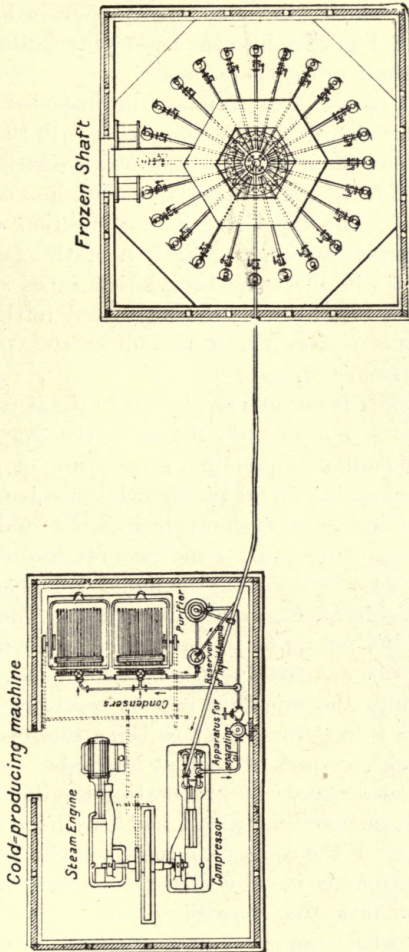

Fig. 339.—Gobert Congelation Method of Sinking Shafts. Plan.

sibly even reach the congelating tubes, if the two substances were not separated. This is effected chiefly by the oil-separator, but, as an additional precaution, a space is provided at the bottom of each congelation tube for the reception of any oil that may be carried

there. The oil retained in the separator is not effectually separated from the ammonia, but is slightly mixed with it. This ammonia, however, is recovered in the purifier, where it is driven off by distillation. The distillation is effected by means of a worm through which steam from the boiler circulates; the ammonia vapour is led by a small curved pipe, seen in Fig. 338, into the main pipe leading the gaseous ammonia from the shaft to the compressor.

Over the centre of the area forming the intended shaft are two pipe-rings, the lower of which is in connection with the ingoing pipe, and receives the liquid ammonia, and afterwards distributes it by the radial pipes to the vertical congelation pipes sunk in a circle below the surface of the earth. The upper ring is in connection with the return pipe, and forms a receiver for the collection of the gaseous ammonia from separate orifices in the same congelation tubes after it has by evaporation in these tubes produced the desired refrigerating effect. The gaseous ammonia is drawn from the upper ring pipe to the condenser through the return pipe.

The liquid ammonia is not allowed to fall to the bottom of the tube and collect in a mass, but in order to cause the evaporation of the greatest possible amount of liquid in a given space of time, the small pipe for leading the freezing liquid through the tube is made to assume either a wavy or a spiral form, as shown in Figs. 340 and 341, in which A represents the congealing tube, B the pipe for leading the freezing liquid, and C small holes for allowing the liquid to escape into the tube, at points more or less frequent, as may be desired. The injecting pipe is led down nearly, but not quite, to the bottom of the congealing tube and both pipe and tube are closed at the bottom. The entrance of the congealing liquid into the injecting pipe is carefully regulated, and descends slowly in a thin stream, the flow being retarded by the waves or spirals, and giving up a part of itself at intervals.

The source of heat necessary for evaporating the liquid is the higher temperature of the surrounding strata, and this heat passes not only through the thickness of the congealing tube, but also across the frozen wall which soon surrounds it. By this arrangement the liquid to be evaporated escapes into the congealing tube at all depths simultaneously, and the whole source of heat available is thus utilised at the same time for evaporating the freezing liquid. In other words, the refrigeration is effected simultaneously at all points.

The diameter, number, and arrangement of the holes in the injecting pipe, and also the pitch of the spirals or undulations, are varied in accordance with the depth in order to produce a greater freezing effect

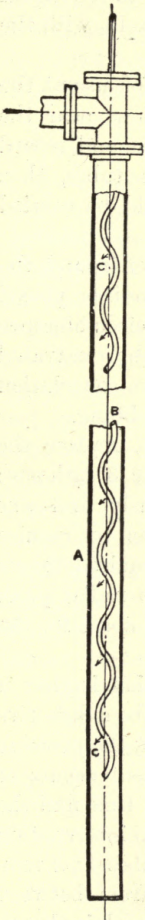

Fig. 340.

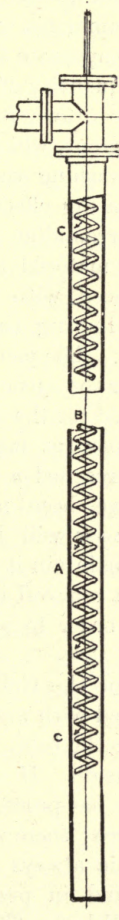

Fig. 341.

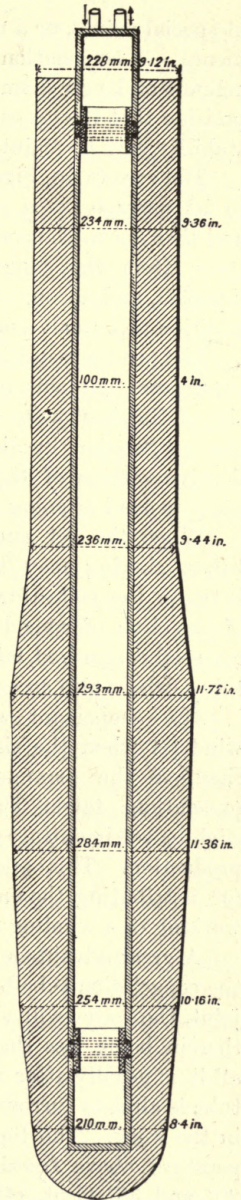

Fig. 342.

Govert Congelation Method of Sinking Shafts. Details of Construction.

at special points, or a uniform freezing, in accordance with the requirements. A congelation may therefore be arranged to have the frozen column of larger diameter at the bottom than at the top, on the supposition that the measures are of uniform consistency, in order that its stability may be maintained while the shaft is being sunk through it.

The arrows in Figs. 338 and 339 show the course of the ammonia in its passage, as a liquid, from the compressor to the condensers, and then on to the congelation tubes, and also its return, in a gaseous state, from the congelation tubes to the compressor, to be again liquefied, and so on. The same ammonia serves indefinitely, with the addition of a small quantity to compensate for waste.

The process requires a large quantity of cold water for use at the condensers, but this must not be drawn from any point so near the site of the shaft as to create a current, which might oppose and retard the congelation by licking or washing the congelation tubes, thus depriving them of their refrigerating effect, which would be carried away instead of going into the surrounding sand.

When the wet sand or loose material has been frozen round the tubes, sinking may be commenced with a small windlass placed between the collecting and distributing rings and the circumference of the circle of congelation tubes. The men enter, and the excavated material is removed, laterally, near the surface, between two congelation tubes, where also access is obtained for the segments of tubing.

More important winding apparatus must, of course, replace the windlass when the sinking has reached a depth of 2 or 3 fathoms; then, if the arrangements have been made judiciously and due precautions taken, the frozen mass will be so large as to require slighter refrigerating power to maintain it than that required for its production. This allows of the removal of one or two radial pipes for distributing the ammonia in order to allow of more space for the working of a winding engine.

A great advantage claimed for the Gobert modification is that if the congelation tube be surrounded with water and there be a defective joint, the water will simply enter the tube, on account of the pressure therein being less than that outside. If such an accident occurs at all it is usually after congelation has proceeded for some time and the tube is already surrounded with ice; there will then be no interruption in the work. The liquid ammonia always enters the tubes at a temperature above freezing-point, and in practice varies from between 20° and 35° Cent. (68° to 95° Fahr.). The cold produced is due to the liquid ammonia becoming volatilised in the tubes.

It is of course impossible to entirely guard against leaky joints. The thrust of the superincumbent measures severely tries them, but special attention has been given to the design of the joints in order to increase their power to resist the strains to which they may be subjected. The method of connecting the ends of congelation tubes has been by screwing one end into another without internal sockets. The thinning of these tubes at the joints frequently causes them to break in being withdrawn from the ground.

The form of joint used by Mr Gobert is shown in Fig. 342. Its chief feature is an internal collar, or ring, shown by crossed hatchings in the section. This collar has an outside flange of the same outside diameter as that of the tubes which it serves to connect. The flange is undercut on both sides so as to be of dovetailed section. Each end of a tube is also bevelled or curved off so as to afford with the collar flange a groove wider inside than out, holding and compressing the lead ring or washer instead of forcing it outwards, thus affording an absolutely tight joint when the ends of the tubes are screwed on to the collar. In some cases, especially for joining the smaller size of tubes, the internal collar is made without a flange, and then only one lead washer is used placed between the ends of the tubes, which must be bevelled and curved just the same as when the collar is flanged. On the tubes being screwed up, they squeeze the washer between them, just as the gland of a stuffing-box compresses the packing. The outer lines of the section, Fig. 342, shows the form and extent to which a tube was covered with ice after having been immersed for thirty-two hours in a tank filled with water; the ice weighed 62 kilogs. (137 lbs.) at the end of the operation. If the tube had been immersed in wet sand instead of clear water, the congelation would have been more rapid. One of the two smaller tubes shown at the top of the congelation tube serves to introduce the liquid ammonia, while the other carries off the gas to the upper ring-pipe.

Instead of ammonia, any other liquid susceptible of easily assuming the gaseous state, such as liquid carbonic acid or liquid anhydrous sulphurous acid, may be employed with a suitable modification of the engine.

CHAPTER XIX

ICE-MAKING

Various Methods of Ice-Making—The Can System—The Wall or Plate System—The Stationary Cell System—Miscellaneous Arrangements for Making Clear or Crystal Ice by Agitation—Holden System of Ice-Making—Water De-aerating or Distilling Apparatus—Vacuum System of Ice-Making—Imitation of Natural System—Ice Factories—Ice-Elevating and Conveying Machinery—Ice-Making, General—Brine—Storing Ice—Ice-Crushing or Breaking Machinery.

THE specific gravity of ice made from de-aerated water is, according to De Mairan, $\cdot926$; its specific heat is $\cdot504$; at a temperature of 32° Fahr. 1 cub. in. = $\cdot033449$ lb., 1 cub. ft. = $57\cdot789872$ lbs.; 1 lb. = $29\cdot896259$ cub. in., or $\cdot0174$ cub. ft. The equivalent of 1 ton of ice is 318,080 thermal units,* that is to say, that this is the amount of heat that would be required to convert 1 ton of ice at a temperature of 32° Fahr. into 1 ton of water at a temperature of 32° Fahr.; or, on the other hand, it is the amount of heat that is necessary to extract from 1 ton of water at a temperature of 32° Fahr. in order to convert it into 1 ton of ice at a temperature of 32° Fahr. The amount of heat that would have to be abstracted from 1 ton of water at 60° Fahr. to form 1 ton of ice at 32° is 382,144 units.

When the manufacture of artificial ice first assumed the proportions of an industry no great thought was given to the quality of the product, and consequently all, or the greater part, of the ice so made was opaque.

Soon, however, a demand for a superior article arose, and it became necessary to introduce means for the production of clear, transparent, crystal ice; the result being numerous inventions and patented devices of more or less efficacy.

The reason why the blocks of ordinary artificial ice are formed opaque is that the rapidity of the freezing process prevents the air contained in solution in the water from escaping, and this opacity in-

* A thermal unit is that amount of heat necessary to raise the temperature of 1 lb. of water 1° by the Fahrenheit scale when at $39\cdot4^{\circ}$. Mech. eq., 778 pounds.

creases towards the centres of the blocks, and is less in hot climates than in colder ones because the quantity of air held in the water decreases as its temperature is raised. Not only is this opacity objectionable by reason of the less pleasing appearance of the ice, but also on account of the far inferior keeping qualities of the article.

VARIOUS METHODS OF ICE-MAKING.

Five methods may be employed for preventing this opacity and forming clear, transparent, crystal ice, viz., by freezing the water slowly at comparatively high temperatures; by agitating the water in cans, moulds, or cases during the process of freezing, so as to admit of the escape of the contained or imprisoned air; by forming thin slabs of ice on what is known as the wall or plate system; by freezing water in shallow stationary cells; and finally by de-aerating or depriving the water of its air before placing it in the moulds or cells.

The first of these plans, besides, at best, only producing blocks of ice partially clear, was so extremely slow, and required the use of such a large number of cans or moulds, and correspondingly large tanks, as to thereby render the first cost of the apparatus ruinously high, and it was consequently soon abandoned altogether; a modification of the same method wherein the temperature of the liquid or medium used for abstracting the heat from and freezing the water was gradually decreased, having likewise experienced the same fate.

The second method or agitation can be more or less successfully carried out in a number of different ways, but has, likewise, certain drawbacks; for instance, complication of mechanism, increased first cost of plant, &c.

The third and fourth methods, or the wall or plate and shallow stationary cell systems are also objectionable, by reason of the extent of the plant required and the slowness of the process.

The fifth method, or that wherein the water is first de-aerated, that is to say, the air is expelled from the water before it is placed in the cans, moulds, or cases, is, all things considered, perhaps the most satisfactory, and is in extensive use in many works where large quantities of ice are made.

As the refrigeration of cold stores or chambers, so also the manufacture of ice with modern machines may be divided into two main systems, that is to say, the one wherein brine previously reduced in temperature in the cooler or refrigerator of the machine is used for

freezing the water, and the other wherein the freezing or congelation is effected by the direct expansion of the refrigerating agent.

It will be readily seen that the latter system enables a very considerable amount of apparatus, essential in the first, to be entirely dispensed with; prevents the loss of efficiency due to a second transmission of heat; and, moreover, avoids the mess and inconvenience so frequently occasioned by a careless or unskilful use of the brine solution.

Much greater difficulties, however, have to be surmounted before the direct-expansion system can be successfully applied to ice-making than is the case with the cooling or refrigerating of cold stores or chambers. In the latter, indeed, all that is required to ensure complete success is a perfectly gas-tight system of pipes, and as a pipe of no very great diameter forms the safest, surest, and least expensive method of imprisoning or confining a gas of a searching nature, it consequently follows that no insurmountable difficulty is here experienced. But the freezing or congelation of water is quite another matter, and requires straight surfaces, as it is not only very difficult to remove the ice that becomes formed round pipes, but a very considerable portion of it is also wasted in so doing. Hitherto attempts to construct straight surfaces with sufficiently gas-tight joints have proved more or less a failure.

Amongst the numerous different methods devised for agitating the water whilst it is freezing, mention may be made of the following:—The insertion into the can or case of a metal or other bar which has imparted to it a vertical reciprocating motion through a revolving shaft and cam or wiper, or by a crank on the shaft, or the placing in the can or case of a wooden or other paddle which is moved to and fro, or of an endless screw or spiral which is rotated by any suitable mechanism. The introduction into the can or case of a pipe extending to within a short distance of the bottom thereof, and through which a current of cold air is forced, which rising in bubbles through the water, produces a circulation in the latter. The imparting of a rocking or oscillating motion to the can or case itself during the freezing operation.

The main objection to those arrangements wherein some form of agitator, or the above-mentioned air tube, is inserted into the can or case is the necessity for withdrawing them, at or near the termination of the freezing operation, to prevent them from being frozen into the blocks of ice.

In the last-named method, the gear for imparting motion to a large number of cans or cases is found to be exceedingly cumbersome, and

has besides to be disconnected, to allow of their being lifted from the ice-making tank or cistern to remove the finished blocks of ice from the cans.

THE CAN SYSTEM.

Fig. 343 shows a patented arrangement of Pontifex and Wood's for making clear or transparent pyramids of ice suitable for table decoration, &c. The ice-making box or tank A is formed of iron, wood-lagged, and the intervening space is filled with sawdust. The ice-moulds or cases B are made of galvanised wrought-iron, and are of a suitable pyramidal form; and the agitators C consist of spirals or endless screws, which are kept constantly revolving, during the freezing of the block, by gut or other bands D, gearing on pulleys E, fixed upon the vertical spindles carrying the spirals or endless screws, and upon a horizontal shaft F, supported in bearings in brackets secured to the side of the tank, to which latter shaft rotary motion is imparted through belt gearing from any available source of power, as shown in the drawing. When the block is nearly frozen solid the agitators must be withdrawn, for which purpose the brackets carrying the spiral, or endless screws, are so secured to the tank as to be readily removable therefrom.

By arresting the freezing action before the block is frozen quite solid the central hollow can be filled up with fruit, flowers, or other objects, and afterwards the congelation completed, thus producing very beautiful effects.

Fig. 344 is a perspective view showing a can ice-box with agitators, which is the oldest and simplest method of making clear or crystal ice. The construction of the apparatus, which is of the Pontifex-Wood improved type, will be apparent from the drawing. The agitators C, which are very readily removable, are operated through rods running upon rollers, to which rods a reciprocating motion is imparted from a rocking shaft G, mounted at one end of the tank, through suitable connecting rods. The ice-making tank A is similar in construction to that shown in Fig. 343, but is of larger dimensions, and is filled with brine, a circulation of which is kept up from the coils of pipes in the cooler of the refrigerating machine by a brine-pump, in

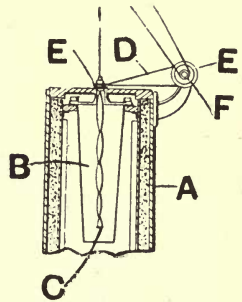

Fig. 343. — Pyramid Ice-making Box or Tank. Vertical Section.

the usual manner. The ice-cans or moulds *B* are formed of galvanised iron, and the blades of the agitators *C* are of wood. To remove the finished blocks of ice from the moulds or cans they are dipped for a few seconds in a tank containing warm water, which may be derived from that running to waste from any convenient source. The sizes of the blocks of ice made vary from 2 ft. \times 2 ft. \times 6 in. in thickness up to 3 ft. 6 in. \times 3 ft. 6 in. \times 12 in. in thickness, and in weight from 1 cwt. up to 6 cwt., according to the dimensions of the cans employed.

Fig. 345 is a vertical longitudinal section showing the "Eclipse" can ice-box made by the Frick Co. The interior arrangement of the trunk and ammonia evaporating pipes or coils, ice-moulds or cans,

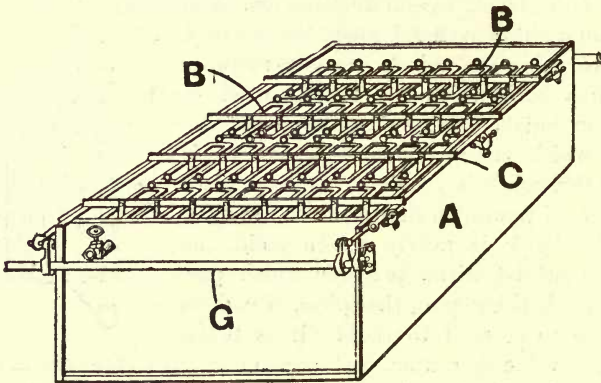

Fig. 344.—Box or Tank for Making Ice on the Can System.

frame-work for holding the cans in position, with the wooden covers, are all clearly shown in the engraving.

Puplett's agitators for liberating the air from the water during freezing are also reciprocated by crank mechanism. They are, moreover, so arranged that as the ice grows, and it becomes necessary or desirable to reduce the width of the paddles or agitator blades, the latter can be feathered by giving them a quarter-turn in + shaped slots.

This system of making clear, crystal, transparent ice has, as already stated, several objectionable features, which may shortly be summed up as follows:—

The blades of the agitators occupying the centres of the cans or moulds whilst the blocks are freezing, have to be withdrawn at the

finish, in order to prevent their becoming frozen into the blocks, consequently the spaces occupied by them during their traverse have to be congealed without agitation, with the result that each block has a narrow core of semi-transparent or almost opaque ice in the centre, which to a slight degree, spoils its appearance, although the keeping qualities of the ice are not affected thereby. If, however, any impurities are contained in the water they become frozen up in the blocks and show through them, to the considerable detriment of their appearance.

The unavoidable freezing of the blocks at different speeds frequently results, with careless watching, in some of the agitator blades or paddles

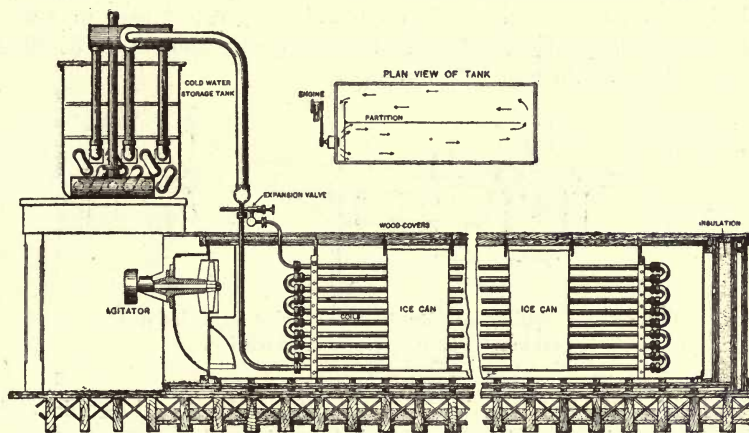

Fig. 345.—“Eclipse” Can Ice-making Box. Vertical Longitudinal Section.

getting frozen in prematurely, and broken off. The cans or moulds are sometimes filled too full of water, which, in consequence of the expansion due to freezing, runs over into the brine solution and dilutes it, in some cases to such an extent as to cause it to freeze or congeal at the ordinary working temperature of the machine.

The additional weight of the cans or moulds which have to be lifted with the blocks of ice entails an extra expenditure of labour, and the constant handling thereof renders their lives short and necessitates a large stock and frequent repairs and renewals.

To obviate the first of these objections, wooden frames have been sometimes placed in the centres of the moulds or cans, inside which the agitators are adapted to work, a block of ice being frozen

up at each end. This, however, gives rise to further serious objections, the wooden frames having to be removed from the moulds or cans with the ice blocks, detached therefrom by means of chisels, and again replaced in the moulds, and a certain quantity of dirty water has moreover to be pumped out of each of the latter before the withdrawal of the ice block and frame therefrom, both of which operations entail much additional labour. The unequal rate of freezing of the blocks causes some of them to come out of an uneven shape and under their proper weight owing to the large holes in their centres.

Every apparatus for making ice on this system should be fitted with an arrangement for automatically supplying to each can or mould a sufficient predetermined charge, and no more. In the absence of this, however, a gauge should be used, and the greatest care in filling the cans should be exercised. The moulds or cans should not be filled to more than within 6 in. of the top.

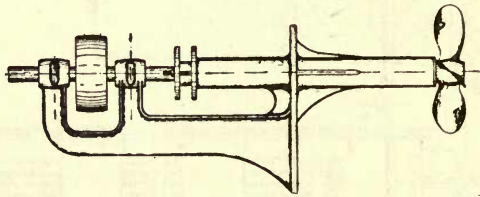

Fig. 346.—Propeller for Circulating or Agitating Brine in Ice-making Tank or Box. Side Elevation.

On the other hand, again, the can system has several well-defined advantages which certainly deserve full consideration. For instance, the first cost of the simple apparatus is low as compared to many others; the blocks of ice produced being, as a rule, of an uniform given size and weight, the necessity for weighing them is dispensed with and they are very convenient to load and pack; should a can become leaky it can be placed on one side for repairs and a spare one inserted in its place without delay; and, lastly, the construction of every part of the apparatus is so simple that it can be made or repaired by any ordinary engineer without special knowledge of ice-making machinery.

The cold brine in the ice-making tank or box is circulated or agitated by means of a duplex, centrifugal, or other suitable pump, or by means of a propeller. The latter, one form of which, made by the "Triumph" Machine Company, is shown in Fig. 346, is the cheapest arrangement, and is sufficiently effective. The shaft of the above propeller is made of the best bronze metal, with three bearings

fitted with ring oilers. The bearings are of double-brace make. This propeller may be operated by belt-gearing from a small engine, or by an electric motor, or any other available source of power.

Fig. 347 is a brine strainer of a pattern made by the Frick Company, and the construction of which is obvious from the drawing, which shows it in vertical central section.

Many ingenious, but mostly complicated and expensive, mechanical arrangements have been also devised for facilitating the handling of the cans or moulds, and so lessening the labour of moving them, a brief description of some of the best and simplest of which will be found at the end of this chapter.

The Freezing Time Required for Can Ice.—With brine at 14°

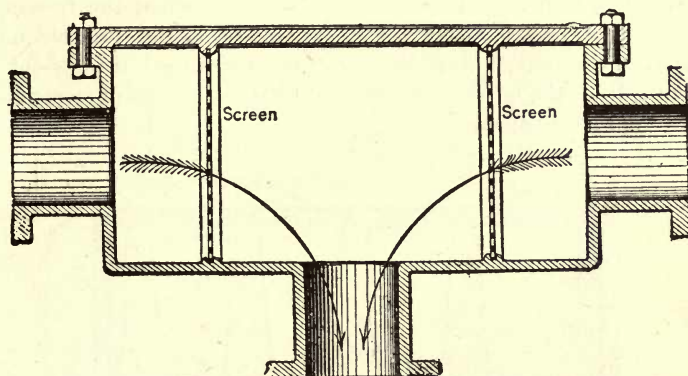

Fig. 347.—Brine Strainer, Frick Pattern. Vertical Central Section.

the average time of freezing different-sized blocks of can ice is, according to Mr F. E. Matthews writing in *Power*, New York, as shown in the following table:—

TIME REQUIRED FOR FREEZING CAN ICE.

| Size of Can. | Weight of Ice. | Freezing Time. |
|---------------|----------------|----------------|
| Inches. | Pounds. | Hours. |
| 6 by 12 by 26 | 50 | 15 to 25 |
| 8 „ 16 „ 32 | 100 | 30 „ 50 |
| 8 „ 16 „ 42 | 150 | 30 „ 50 |
| 11 „ 22 „ 32 | 200 | 50 „ 72 |
| 11 „ 22 „ 44 | 300 | 50 „ 72 |
| 11 „ 22 „ 57 | 400 | 50 „ 72 |

While no exact rule, says the same authority, can be formulated for expressing the freezing time in terms of difference in temperature between the brine and the freezing water in the can, because of the fact that the heat-transmitting surface of the freezing water is decreasing and the insulating effect of the ice forming is increasing, it, nevertheless, has been claimed by some that the time required for freezing can ice with brine at the usual temperature varies directly as the square of the thickness of the cake of ice. On this basis the relative time of freezing 6-in. and 11-in. blocks would be as 36 is to 121, or, allowing 50 hours for the latter, the former should freeze in 14.9 hours.

In 1885 Carl Linde patented an invention designed to overcome the objection to having to remove the agitators when the freezing of the blocks of ice is nearly completed, by providing suitable means whereby a horizontal flow of water is determined throughout the whole depth of the mould from one end to the other during congelation by external mechanism.

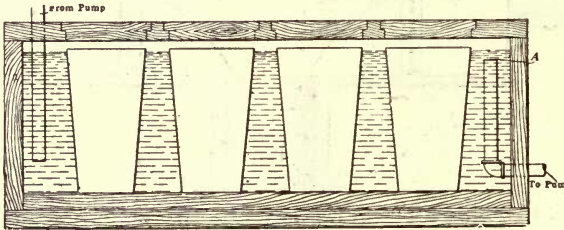

Fig. 348.—Arrangement of Freezing Tank on Can System, showing cause of Brine Foaming.

THE FOAMING OF BRINE.

Trouble is sometimes experienced with brine foaming when drawing the ice in plants on the can system. When this foam is thick it is liable to get into the cans when replaced in the ice-making tank and spoil the water for the purpose of ice-making. Foaming may be caused by too large a number of cans being drawn from the ice-making tank together, and the level of the brine therein consequently falling below that of the suction to the brine pump, thus allowing the ingress of air. Fig. 348 shows the arrangement of piping in tank.

THE WALL OR PLATE SYSTEM.

In the plate or wall system which was invented by Twining and Harrison in 1850-56, one or more hollow or cellular plates or walls of sheet or cast iron are fixed in a properly insulated tank, which contains the fresh water to be frozen, and a circulation of cold brine is kept up through these hollow plates or walls. The brine is either cooled in a brine-cooler or refrigerator by evaporating coils connected to the gas-pump or compressor, in the case of an ammonia compression machine, or to the absorber in an ammonia absorption machine, in the usual or ordinary manner; or the refrigerating coils may be placed within the hollow or cellular walls or plates themselves. In a short

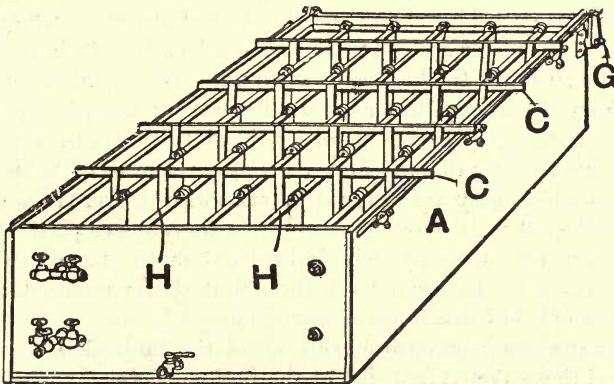

Fig. 349.—Box or Tank for Making Ice on the Plate or Wall System.

time ice will begin to form on both sides of the plate, and layers of ice become gradually built up thereon. To remove these layers or slabs of ice, the cold brine is withdrawn, and warm or tepid brine passed into the hollow or cellular plates or walls when the slabs are melted or thawed off and detached therefrom.

In Fig. 349 is illustrated an improved ice-making tank or box on the wall or plate system, also designed by Pontifex and Wood. The construction and operation of an apparatus of this type has been already briefly described at the commencement of this chapter. The hollow or cellular walls *H*, which are formed of galvanised iron, are, as will be seen from the drawing, fixed vertically to the hollow cast-iron ends of the tank *A*. The agitators *c* are similar in construction to those shown in Fig. 246, and are reciprocated in a like manner. The cold

brine is circulated through the hollow ends and hollow or cellular walls, and suitable cocks and connections are provided which admit, when the freezing is finished, of the cold brine being completely drained out of the hollow or cellular walls into the cold brine tank, and warm brine being introduced, by a small pump, from a warm brine tank heated by a coil of pipes, so as to melt or thaw the ice slabs off the walls or plates and leave them ready for removal.

The hollow or cellular walls are, moreover, so constructed as not to reach quite to the bottom of the ice-making tank, and in this space all the impurities voided by the water settle. The freezing is generally continued until the slabs of ice extend to within a quarter of an inch of the blades of the agitators, when the cold brine is shut off and turned on to another tank from which the ice has been just removed.

The agitators are lifted out, and the slabs of ice, which when melted off the walls or plates are generally 14 ft. in length, 3 ft. in depth, and from 6 to 10 in. in thickness, are sawn into convenient lengths, and raised from the surplus water in the ice-making tank, in which they remained floating, by means of an overhead traveller, by which they are deposited, either directly into a cart for removal, or upon a platform from which they are dragged or otherwise delivered into the ice store. When the slabs are detached from the walls or plates, the hot brine is shut off and completely drained out of the latter, the water again filled up to the usual level, the agitators are replaced, and the circulation of cold brine is again turned on.

The water must be entirely run out of the tank about once every week, and the sediment and dirt at the bottom thoroughly cleared out.

The most recent method adopted by the Pulsometer Engineering Co., Ltd., is an arrangement for the production of ice on the direct expansion system. In this the freezing coils are covered by two plates immersed in the water to be frozen, the liquid ammonia is allowed to expand in the freezing coils, and the ice is formed on the surfaces of the plates. The releasing or thawing-off of the ice is effected by allowing the hot gas from the condenser to flow into the coils. The ice produced by this system is generally 8 in. thick and 8 ft. by 6 ft., but can easily be made up to blocks 17 in. by 8 ft. by 6 ft.

The quality of the ice produced by this latter method is said by the makers to more nearly resemble the finest quality of Norway ice than anything else yet produced, and owing to there only being one transfer of heat the economy is increased.

This system of pipes, valves, and receivers is made of wrought iron or wrought steel, no cast iron or cast steel being employed on account

of the danger involved by the use of these materials. The pipe joints are of an improved type, being remarkably simple and perfectly gas-tight. With the object of getting over the trouble caused by coil condensers and refrigerators becoming blocked with oil, an arrangement is provided whereby the oil can easily and certainly be withdrawn from the machine, thus keeping the coils clean.

An apparatus for making ice on this system, invented by Mr J. H. Laurensen and Mr W. T. Thorne, consists in so disposing and arranging the slabs within a tank containing the water to be frozen that when the refrigerant is circulated therethrough the water between adjacent slabs is frozen into complete blocks, instead of the ice being formed into blocks about and around the heat-exchanging units from which, after being thawed off, the blocks have had to be disengaged by "barring," the joints of the units being apt to be damaged in this operation and the appearance and keeping qualities of the blocks not being so good by reason of the holes left therein. Means are also provided in this invention for causing an air agitation of the water between the slabs and for so arranging the trunk and branch connecting pipes for the refrigerant medium to the slabs that the medium may either be circulated from the compressor through the condenser and slabs back to the compressor suction for freezing, or alternatively direct from the compressor outlet by a reversed flow through the slabs and back to the compressor suction for thawing off; or again, the medium after passing direct from the compressor and being reversed through one or more slabs for thawing may be short-circuited direct to the normal freezing inlets of other slabs and expanded therethrough for freezing before finally passing to the compressor.

The ice generally made by this class of apparatus is of very superior quality, being of great purity, and of a most attractive, brilliant, clear appearance, and it is in great demand for use in restaurants, clubs, &c., fetching a higher price than other makes.

There are, however, certain drawbacks to its use, the principal one of which is that the ice cannot be obtained in blocks of uniform size and weight without an expenditure of considerable labour in cutting them into shape. In case of any necessity for repairs arising, moreover, the whole of one of the ice-making tanks or boxes has to be shut off, and is thrown out of use. The plate or wall system, besides, is necessarily very slow, from the fact of the freezing process going on on one side only, instead of from four opposite sides conjointly, as in the can system, wherein the four surfaces, growing gradually together in the centre, finally unite into a solid block of ice the

width of the can. If, therefore, a slab or block of ice of an equal thickness is to be formed on a plate or wall congealing only from one side, the time occupied in freezing it will be quadrupled. To ensure the quality of the product, moreover, care must be taken to use pure water. Mr F. E. Matthews, dealing with this subject in *Power* of New York, says that the principal inorganic impurities to be guarded against are the salts of iron which give a reddish discoloration, and the carbonates and sulphates of lime and magnesia which produce a slight cloudiness. Unless large quantities of magnesium carbonate or carbonate of iron are present the effects of these impurities, as well as that of air, can be overcome by increased agitation. In the case of carbonates of either magnesia or iron, increased air agitation may tend to increase the discoloration through the hydrating of the former and the oxidising of the latter. This difficulty may be overcome, however, by the substitution of mechanical for air agitation.

The advantages over the can system may be enumerated as follows:—The ice made is, as above mentioned, of a very superior quality. The liability of any of the agitator blades becoming frozen in and broken off is very slight. Only the ice itself having to be handled, the weight to be manipulated is considerably reduced. The ice-making tanks can be shut off when the ice is finished, and left until it is convenient to remove the ice, thus admitting of night-shifts of labourers being dispensed with. Owing to there being no parts, like the movable cans or moulds, liable to rapid deterioration, less expenditure on repairs is required. No possibility exists of the brine solution being weakened by the accidental spilling of water into it, as in the former system.

THE STATIONARY CELL SYSTEM.

Transparent ice is also formed in deep cells provided with agitators. In the latter case a number of cellular or hollow walls of wrought or cast iron are fixed in a suitably insulated tank or cistern, the water to be frozen being placed between these walls and the refrigerated brine circulated through the hollow walls of the cells therein. The ice gradually forms on the outside, and increases in thickness until the two opposite layers meet and join, but the freezing may be stopped at any time and the ice removed. This latter operation can be very conveniently effected by passing brine at a higher temperature through the cells.

The stationary cell system, when employed to make clear or

transparent ice without agitation, or using water that has been deprived of its air, consists of a number of shallow pan-shaped cells having hollow walls, through which a circulation of cold brine is kept up. The ice is removed therefrom as in the plate or wall system.

The plan wherein stationary cells are employed consists in the provision of fixed or stationary shallow pans or moulds having hollow walls, the intervening spaces being open at the top. These cells or moulds are filled with water, and a circulation of cold brine is passed through the hollow walls and the water frozen, after which the cold brine is stopped off and completely drained out of the hollow walls, and warm brine is caused to circulate therethrough, melting or thawing off and loosening the blocks, which can then be easily removed from the cells or moulds, which are then refilled and the operation repeated. In this system an entire tank has to be emptied at once, as in the plate or wall system; therefore, in order to make the operation continuous, at least two tanks must be provided.

If the cells are constructed deep in proportion to their width, that is to say, substantially similar in form to the moulds or cases used in the can system, then the freezing or congealing of the water will be as rapid as in the latter, but agitation, de-aerated water, or other means will have to be used if crystal ice is required. If, however, they are made shallow, and pan-shaped, then the freezing being almost entirely done from the bottom will be extremely slow, as it is in the plate or wall system, where the formation of ice is also effected upon one side only.

The advantage of forming the cells shallow is that clear transparent crystal ice can be made in them without agitation or using water for freezing that has been de-aerated or deprived of its air. The slowness of freezing is, however, on the other hand, a great drawback, and is the chief objection to the use of the shallow stationary cell system; as the congelation of a block of ice on this plan, of equal thickness to one formed in a deep can or mould or in a deep stationary cell, takes about four times as long, it is evident that the apparatus requisite for an equal output must become cumbersome and expensive.

Fig. 350 is a perspective view showing a Pontifex-Wood patent cell ice-making tank or box, the main novel feature in which is the arrangement of the agitators externally to the spaces where the blocks or slabs of ice are formed. The apparatus consists in a tank A, with a galvanised wrought-iron hollow or double bottom, two galvanised cast-iron hollow cross walls or partitions I, and a number of short galvanised cast-iron longitudinal hollow walls J, fixed at right angles to the cross

walls, and so that there is a space or clearance left between their adjacent ends in the middle of the tank, and between the other ends and the extremities of the tank, in which open spaces are placed the agitators *c*. The movements of the latter give an impulse to the water, causing it to rush in waves between the longitudinal walls and wash out all the impurities thrown off or voided by the water during the freezing process, which impurities settle at the bottom of the open spaces. In this arrangement the two layers of ice, gradually growing in thickness between each two longitudinal walls, at last meet and freeze together, so as to form a solid block or slab of ice of a given size and weight.

To remove the blocks of ice they are first loosened or melted off

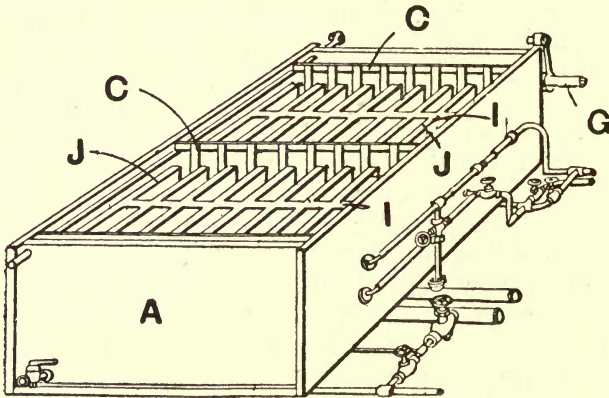

Fig. 350. —Pontifex-Wood Cell Ice-making Tank or Box.

in a similar manner to that employed in the ordinary plate or wall system, after which they are gently started away from the cross walls to enable the ice-grips to grasp each end, or have loops frozen in, and are then lifted out by an overhead traveller in the usual way.

The only ones of the hereinbefore-mentioned objections to which this arrangement seems open are that when an ice-making tank or box is in need of any repairs it has to be completely shut off, and the capacity of the apparatus is thus reduced for the time being, and, owing to the space occupied by the agitators being lost for ice-making purposes, the size of the apparatus required for a given output has naturally to be somewhat increased.

The advantages claimed by the inventors are as follows:—The

blocks of ice are produced of a uniform size and weight, and are convenient to manipulate, load, and pack. The ice is of superior purity and appearance, and the slabs are of great thickness and durability. There is no liability to breakage of any of the blades of the agitators. There are no cans or moulds to handle or repair. The walls are fixed, and the general arrangement is of very great strength and practically indestructible. Only the actual ice itself has to be handled, therefore less weight has to be moved in comparison with the can system. No cutting up and consequent waste or weighing of the ice is required, as in the wall or plate system. When an ice tank or box is finished, it can be shut off by simply turning the cocks and left till it is convenient to remove the ice. Thus all the tanks or boxes can be set so as to be completed during the day, and no night-shift of labourers is required. And, finally, the water cannot spill into the brine and weaken it, as it does in the can system, unless considerable care be exercised.

The sizes of the blocks of ice made in these boxes run from 3 ft. 6 in. by 3 ft. 6 in. by 9 in. in thickness up to 3 ft. 6 in. by 3 ft. 6 in. by 1 ft. 9 in. in thickness, and the weight likewise varies in a corresponding ratio from about $4\frac{1}{2}$ cwt. up to $10\frac{1}{2}$ cwt. each. Very thick blocks are not, however, found to be commercially successful, inasmuch as they take too long a time to freeze or congeal.

Where clear ice is required in blocks of, say, 5 cwt., the Pulsometer Engineering Co., Ltd., use a special form of tank, composed of hollow cells forming squares the size of the blocks required, the water in which is agitated during freezing. The result is a block of ice almost perfectly clear and weighing about 5 cwt.

As in the ordinary wall or plate system, every plant working with the above-described ice-making tanks or boxes, in order to render the process continuous, must have a set comprising two or more of the latter. Thus a 4-ton plant has two boxes, a 6-ton three boxes, a 9-ton three boxes, a 15-ton either three or four boxes, and a 24-ton either six or eight boxes.

MISCELLANEOUS ARRANGEMENTS FOR MAKING CLEAR OR CRYSTAL ICE BY AGITATION.

Hill's method of making clear or crystal ice (British Patent No. 16253 of 1889) is shown in Figs. 351 and 352, which represent respectively a plan of the ice-making tank or box partly in horizontal section and with the lid or cover removed, and a vertical section on the line

x-x of the previous figure. The apparatus comprises a vessel or tank *P*, which is provided with a lid or cover (Fig. 352), and with a jacket or casing *Q*, the intervening space between the jacket or casing and the tank *P* being filled with any suitable non-conducting material as at *Q*¹. When clear ice is to be made, the liquid to be frozen is con-

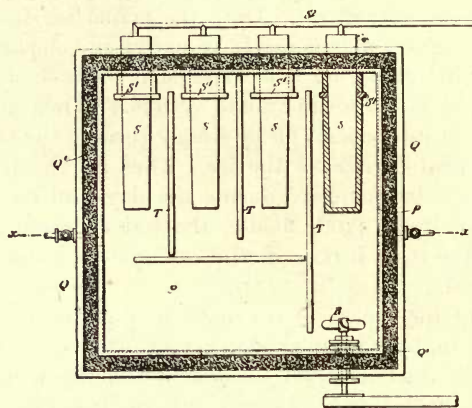

Fig. 351.—Hill's Method of Making Clear or Crystal Ice. Plan of Box or Tank.

tinuously circulated in the vessel or tank *P* by means of a rotating screw *R* or other suitable device. Into the vessel or tank *P* project freezing vessels or chambers *S*, so that the water in the vessel or tank *P* will be frozen on the exterior of the chambers *S*, and the hollow

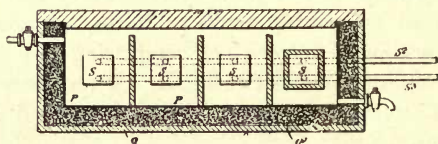

Fig. 352.—Hill's Method of Making Clear or Crystal Ice. Transverse Section on line *x-x*, Fig. 351.

blocks of ice thus formed can be very readily removed therefrom. For this latter purpose the chambers *S* are made slightly conical or taper from their outer to their inner ends, and rings *S*¹ are fitted loosely thereon to further facilitate the removal of the hollow blocks of ice. Either the direct expansion or brine circulation may be used for freez-

ing purposes. In the first case the liquid ammonia is forced into the chambers *s* through a pipe *s*², and is then allowed to expand and return to the absorber of an absorption machine, the weak liquor, which cannot be vaporised without the application of heat, being allowed to return to the ammonia boiler through a pipe *s*³. In the second case brine reduced to a very low temperature by any suitable process is

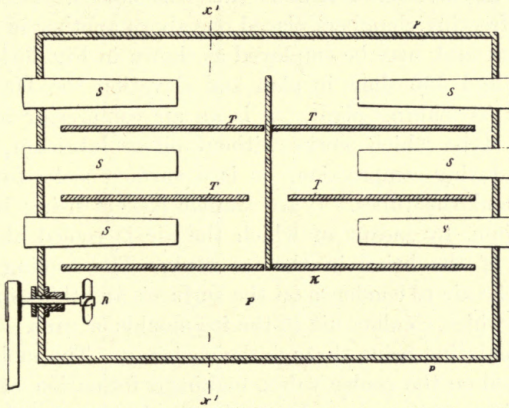

Fig. 353. —Modified Arrangement of Hill's Method of Making Clear or Crystal Ice. Horizontal Section.

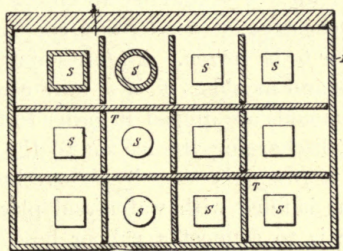

Fig. 354. —Modified Arrangement of Hill's Method of Making Clear or Crystal Ice. Transverse Section on line *x'-x'*, Fig. 353.

caused to circulate through the chambers *s* for the further purpose of freezing the water on the exterior thereof.

To ensure the proper circulation of the water to be frozen in the vessel or tank *P*, partitions *T* are provided in the latter, which are so arranged that they can be readily removed to permit the withdrawal of the hollow blocks of ice from the chambers *s*.

In another arrangement, shown in horizontal section in Fig. 353 and in vertical transverse section on the line $x'-x'$ of the latter in Fig. 354, a series of the freezing chambers s at each side of the tank p are provided, leaving a space between them of slightly greater length than the blocks of ice to be produced, so that the blocks from one series of chambers can be first removed and then those from the other series, and space in the ice box or tank is thus economised. Several rows or series of the freezing chambers placed one above another in the freezing or ice vessel or tank may be employed as shown in Fig. 354.

Figs. 355 and 356 show in plan and elevation the Haslam patent air agitation ice-making plant. A is an air compressor of the water displacement type which works without oil or lubricant, and partly cools the air during compression. B is a surface cooler further cooled by water round the tubes. c are similar coolers using brine as the cooling medium, by means of which the air is cooled almost to the temperature of the brine in the ice tank. The cooling causes the moisture in the air to condense on the surfaces, and this avoids freezing up the pipes which conduct air to the ice moulds or cans. D is a small pump for circulating brine through the coolers c . The moisture in the air is deposited on the cooler tubes, making a formation of hoar frost. This would, in time, cause an obstruction to the passage of the air, but by a simple arrangement of change over valves the coolers c are used alternately, so that one cooler is thawing off whilst the other is in use for finally cooling the air. The cold dry air enters at the bottom of the cans by a specially constructed nozzle, and this produces the desired agitation of the water to be frozen. E represents the ice-making tank with its cooling coils and moulds. F is a tank containing tepid water into which the ice moulds are dipped in order to free the blocks, and G is the can tip for discharging the ice on to the platform. The ice cans are lifted out a row at a time by an overhead travelling crane. When a row of cans is filled with water and placed in the tank, all that has to be done is to connect a rubber hose with the main and open the air valves.

An apparatus for making transparent ice, invented by Mr R. J. Berryman, Washington, U.S., consists in a tank having receptacles partly submerged in a fluid cooled by refrigerating pipes or hollow plates. The freezing action is stopped before the water is completely frozen, and the receptacles are subjected to the action of a thawing medium without being removed. Air or ozone is discharged in jets from pipes arranged longitudinally in the containers so that the inside faces of the plates of ice are straight and parallel. The unfrozen

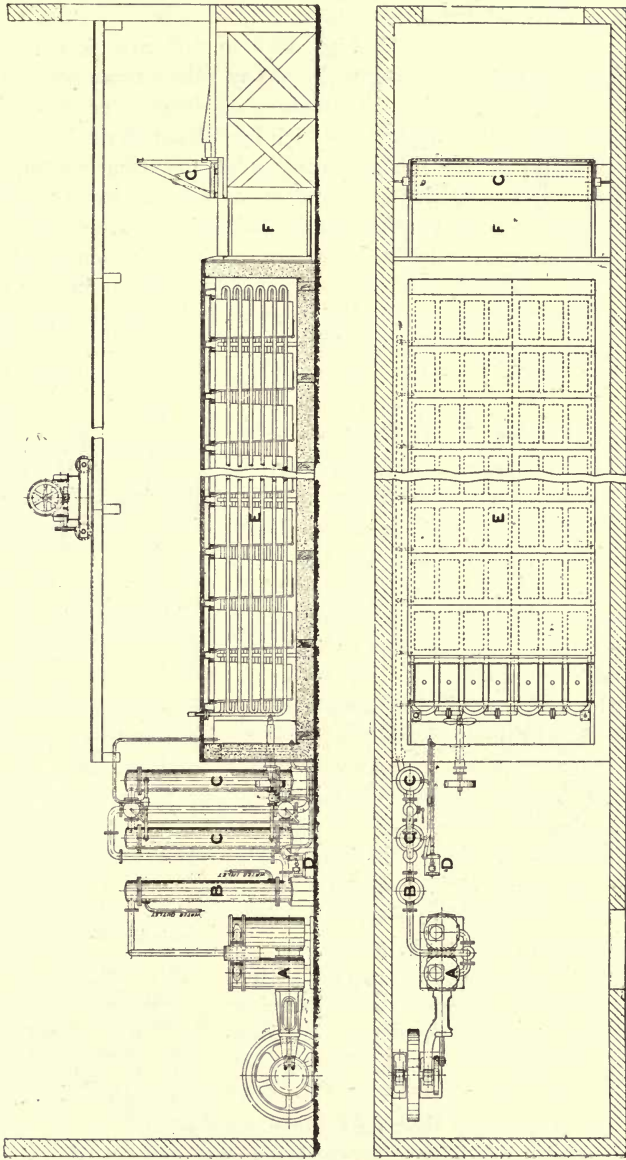

Figs. 355 and 356. — Haslam Patent Air Agitation Ice-making Plant. Sectional Elevation and Plan.

water containing the impurities is drawn off through apertures in the bottom of the containers.

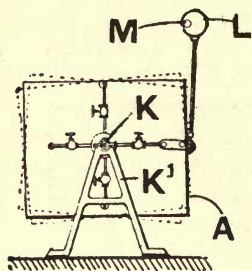

Fig. 357.—Oscillating Ice-making Tank or Box.

In Figs. 357 to 363 are shown a few amongst the many other arrangements for the manufacture of clear or crystal ice by agitation which have been devised.

An arrangement for ensuring the production of clear or crystal ice by the imparting of an oscillating movement to the tank or box A, in which the ice moulds or cans are suspended, is shown in Fig. 357, which depicts an end view of the apparatus. The tank is suspended, as will be seen from the illustration,

upon trunnions κ , supported in bearings in standards κ^1 , and an oscillating or rocking motion is imparted to it by means of an eccentric L upon a rotating shaft M. The cold brine or other freezing medium is admitted through the trunnions κ , which are formed hollow for that purpose, to the bottom of the tank A.

The finished ice can be removed by the substitution of warm for the cold brine to thaw off the blocks, and by inclining the tank sufficiently to admit of their sliding out.

In another type of apparatus of this class, each of the cans or moulds is supported in the freezing tank on central pins or trunnions resting in fixed bearings. An oscillating movement is imparted to each can by forks on a rocking shaft engaging other pins placed near its upper end.

Numerous arrangements for agitation by means of a piston or pump of some description have been designed, some few of which are shown in Figs. 358 to 363 by way of examples.

The first of these, or that shown in Fig. 358, consists of a partially-submerged plunger pump N, the ports of which are inclined as shown in the drawing, so as to set up currents in

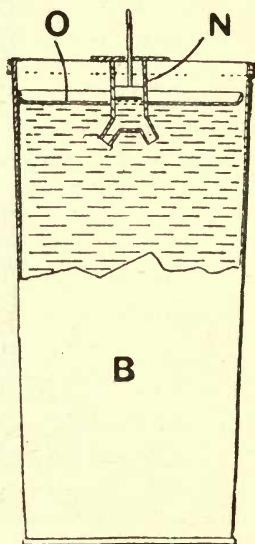

Fig. 358.—Arrangement for Agitation of Water in Ice Cans by means of partially submerged Double-ported Plunger Pump. Sectional Elevation.

the necessary directions, shields or guards *o* being fixed above the water level to prevent the latter from splashing out of the can or mould *B*.

In the illustration the pump *N* is shown arranged vertically, but it can also be fixed to work horizontally.

The second arrangement of pump agitator illustrated in Fig. 359 has the refrigerating tanks placed in series in such a manner that the brine can pass from one to the other through the passages provided for that purpose. The pump *N* is shown at the right-hand side of the figure, and consists of a barrel and plunger or piston worked off a crank. The water is forced by this pump at each downward stroke of the plunger along a channel or passage beneath the moulds or cans *B*, and passes up the latter through holes or apertures *B*, provided in their bottoms.

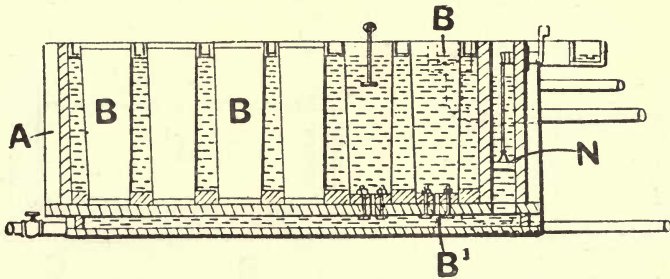

Fig. 359.—Arrangement for Agitation of Water in fixed Ice Cans by means of a Plunger or Piston Pump. Vertical Longitudinal Section.

On the completion of the congelation of the water in the moulds, the cold brine is drawn off from the tank, and warm water or air is introduced through suitable pipes, so as to thaw off the blocks of ice, and admit of their withdrawal. The moulds or cans are connected together by tie-bars, and a number of them are arranged in one frame.

In another arrangement shown in Fig. 360, in which the water in removable moulds or cans is agitated by the action of pumps, the moulds *B*, which are of thin sheet metal, and arranged transversely in a brine tank *A*, are each divided by a non-conducting partition into two compartments communicating through suitable openings. The larger of these compartments is that in which the water is frozen, the smaller one forms a pump barrel *N*, and in it a piston or plunger *N*¹ is reciprocated. The plunger rods are coupled to a bar arranged

longitudinally, its ends working between suitable guides, and an up-and-down motion is imparted to it from a rocking shaft *q*.

Figs. 361, 362, and 363 illustrate types of pump or piston agitators, in which the water in the tanks themselves is intended to be frozen, no separate ice cans or moulds being employed. In the first arrangement (Fig. 361) the tank *A*, containing the water to be frozen, is fitted with a second bottom as broad as the tank, but with a clearance, as shown in the illustration, which represents a longitudinal vertical section through it at each end. In the clearance between the two bottoms of the tank is mounted an agitator *R*, as broad as the tank *A*, and to which reciprocating motion is imparted by connecting-rods from cranks on a rocking shaft *q*. The freezing is effected by narrow longitudinal

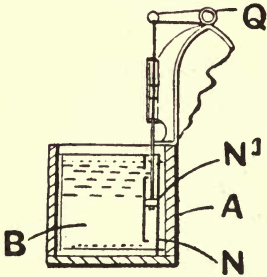

Fig. 360.—Arrangement for Agitation of Water in Removable Ice Cans or Moulds by means of Plunger Pumps. Transverse Section.

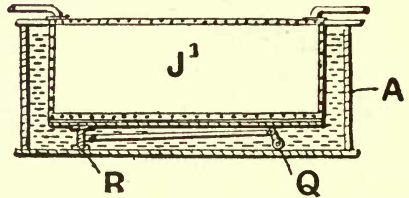

Fig. 361.—Arrangement for Agitation of Water to be frozen in Ice-making Tank or Box by Long Horizontal Agitator. Transverse Section.

brine cells *J*¹, suspended from the edges of the tank at their upper ends, and resting on the second or false bottom at their lower ends. These brine cells are alternately connected at the ends through unions, or tubes, in such a manner as to admit of the brine being passed through the whole series, a four-way cock supplying or withdrawing it in either direction to other tanks or to the refrigerator.

Steam can be passed through the cells to admit of their removal after freezing is completed.

In the arrangements shown in Figs. 362 and 363, pump chambers *N*, and plungers or pistons *N*¹, are employed, that in the first being arranged vertically at the side, and that in the second horizontally beneath the tank *A*. The plunger or piston-rod is so mounted as to

have a certain movement in the plunger or piston, so that, on the up or backward stroke of the latter, it will operate to open a valve and admit of the water passing through, whilst on the downward or forward stroke it will, on the contrary, close the valve so that the water will be driven through the openings. In this arrangement it will be seen that the water is only driven in a downward or one direction, but it can be also so arranged as to drive it in an upward or in both directions. The piston or plunger-rods in both arrangements are operated by bell crank levers s. Several of the above cuts are reproduced from articles by the author which appeared in *Modern Machinery*, of Chicago.

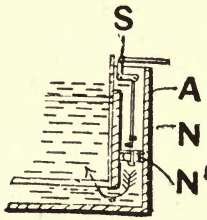

Fig. 362. — Arrangement for Agitation of Water [to be] frozen in Ice-making Tank or Box by means of Vertical Plunger Pump. Transverse Section.

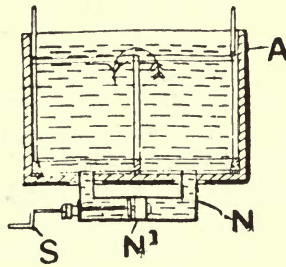

Fig. 363. — Arrangement for Agitation of Water to be frozen in Ice-making Tank or Box by means of Horizontal Plunger Pump. Transverse Section.

Mr T. B. Lightfoot designed and patented in 1885 a combined refrigerating and ice tank in which the cans or moulds are arranged between coils or pipes, through which a vaporised freezing medium is caused to circulate, the moulds or cans and pipes being surrounded by brine or other uncongealable fluid not mechanically circulated.

THE HOLDEN SYSTEM OF ICE-MAKING.

A system of ice-making which is used to a considerable extent in the United States is that invented by Mr D. L. Holden (who may be said to be one of the pioneers of the ice-making industry in that country), which he terms the "regealed ice machine." The method of procedure is substantially as follows:—The cold is obtained by the expansion of the liquid ammonia. Centrally, in a water tank or reservoir, is located a horizontal metal cylinder, the extremities of

which form hollow gudgeons extending to the outside of this tank, and are provided with suitable means through which rotary motion can be imparted to the cylinder. The liquid ammonia anhydride is delivered into the above-mentioned cylinder at one of its ends, and forms a thin layer upon the inner wall of the revolving cylinder, in which it expands, vaporises, and is carried off from the other end. Upon the exterior of the cylinder a thin coating of ice is formed, which is constantly removed by a set of scrapers, and this ice, floating in the water, is conducted by a worm or other conveyor to two cylinders, in which a piston operates, to subject it to a pressure of 50 lbs. per square inch for the purpose of expelling all excess of water and air bubbles.

An installation on this system requires a far simpler apparatus than that which has to be provided for carrying out the process of ice-making by means of any of the systems usually employed, and it has moreover, according to the inventor, the further advantage of enabling work to be started with comparatively little delay as compared with that entailed by other plants, which in some cases require one or more days' preparation. As the thin layer or coating of ice is constantly and rapidly formed on the external surface of the internally cooled metal cylinder, the process is more expeditious than is the case when the freezing or congelation of the water takes place in a mould or can, where the formation of ice at the sides considerably retards the process and renders it very slow.

WATER DE-AERATING OR DISTILLING APPARATUS.

The last of the plans mentioned for making clear or transparent ice, or that wherein the water to be frozen is first de-aerated or deprived of its air, is usually carried out in an apparatus working on the can system, but the water so treated may be used in the cell or any other system with equally favourable results.

The process of de-aerating the water is one of the utmost simplicity, and the product is found to answer admirably, the ice produced being of prime quality.

The methods used for extracting the air from the water are either by subjecting it to a long-continued boiling, by exposing it to a high vacuum, or by distilling it under exclusion of the atmosphere.

In order, however, to economise fuel, it is a not unusual practice to utilise the exhaust steam from the engine for the purpose of ice-making, as has been already mentioned; and as this exhaust steam contains an admixture of more or less of the lubricating oil from the

engine cylinder, it must be deprived of this before being thus used. This is very easily accomplished by passing the exhaust steam through steam-filters of very simple construction, and after the steam has been thus filtered it is condensed, and the resultant water is again thoroughly filtered so as to as completely as possible deodorise it. The can ice produced from this de-aerated or air-freed water still contains a very thin stratum or core of porous ice in the centre, but it is insignificant and not sufficient to injure the appearance of the blocks to any appreciable extent.

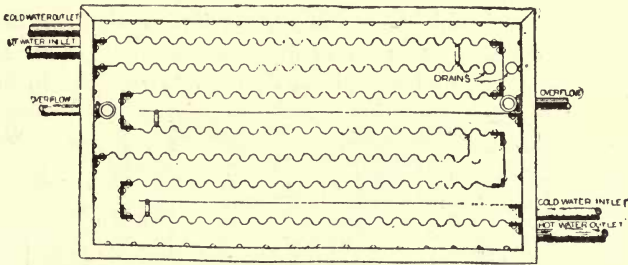

Fig. 364.—Plan.

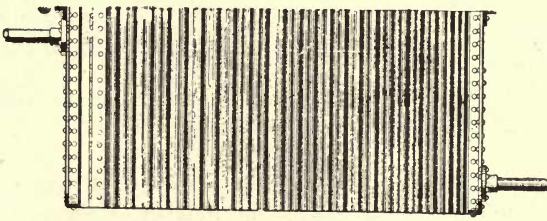

Fig. 365.—Vertical Section.

Oil Separator and Condensed Water-Cooler, Triumph Ice Machine Co.

The Klein oil separator or collector consists of a number of dished perforated plates set zigzag fashion in a cylindrical or a rectangular casing. The Triumph Ice Machine Co.'s oil separator and condenser water cooler is shown in plan and vertical section in Figs. 364 and 365. The distilled water runs round one channel, formed with corrugated walls, whilst the cool water passes in the opposite direction. This corrugated construction gives a very large amount of cooling surface whilst occupying a comparatively small casing.

Fig. 366 is a diagrammatical view showing an apparatus employed

by the Frick Company for making distilled water from the exhaust steam from the driving engine.

Another method of utilising the exhaust or waste steam for de-aerating or producing water freed of its air by employing it for the evaporation or distillation of other water in a suitable still or apparatus, as, for example, a triple-effect distilling apparatus, or in a single-effect, or, for very large plants, a multiple-effect evaporator of the Yaryan type.

The operation of the ordinary type of triple effect is shown in the diagram, Fig. 367.

The triple effect, which is a modification of a vacuum pan, or rather a modified arrangement of vacuum pans, is the invention of Mr Rilleux, a Franch gentleman, and was primarily intended for use in factories

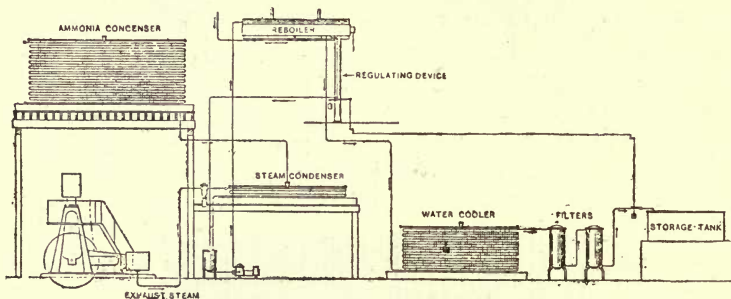

Fig. 366.—Apparatus for Making Distilled Water from Exhaust Steam. Frick Company. Diagrammatical View.

making beetroot sugar. Double-effect apparatus of this type is also constructed, and in some instances the number of effects is increased to four (quadruple effects), which is the usual limit in this system.

In the diagram, A, A¹, A² indicate the three pans or vessels forming the effects, in the upper parts of which are spaces to receive the steam or vapour evaporated, and the lower part of each pan or vessel being fitted with two tube plates or diaphragms, which are set with suitable tubes c, to allow the water to be evaporated to obtain access and to circulate below the lower tube plate and above the upper tube plate; and the space between these tube plates and round the exterior of the tubes constitutes the calandria or heating chamber B.

The upper portion of the pan or vessel A is connected with the heating space or calandria of the pan or vessel A¹, and the upper portion of the latter is connected with the heating space or calandria of the

pan or vessel A^2 by means of pipes E , fitted with safes or traps E^1 , and the upper portion of the pan or vessel A^2 is connected through the pipe E with a condenser.

The lower or water spaces of the pans or effects are connected together by pipes F .

The calandria of the pan or vessel A is heated by either waste steam or of live steam delivered through the pipe G , whilst the steam or vapour evaporated from the water in the pan or vessel A is employed to heat the calandria of the pan or vessel A^1 , and that from the latter the calandria of the pan or vessel A^2 , the steam or vapour evaporated from the water in the latter passing to the condenser through the pipe E .

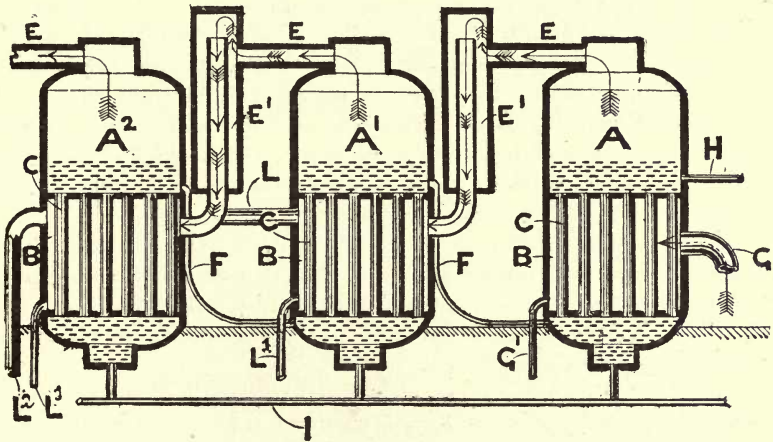

Fig. 367.—Diagram Illustrating Operation of Triple-Effect Evaporating Apparatus.

It will thus be seen that the second effect or pan forms a condenser to the first, and the third a condenser to the second, the third being in connection with a surface condenser, which may be employed to heat the feed-water, and thus form a heat interchanger.

The condensation water from the calandria of the first pan or effect A is delivered by the steam-pressure into a hot well, that from the calandrias of the second and third pans, as well as that from the surface condenser connected with the latter, is delivered by suitable pumps into the distilled-water receiver. H is a pipe for charging the apparatus with the water to be distilled or evaporated. I is a pipe connected by branches to a well in the bottom of each pan. L is a

pipe connecting the upper part of the heating space of the calandria B of the second pan A^1 with that of the third pan A^2 . G^1 is a pipe by which the water resulting from condensation in the calandria B of the first pan A is discharged into a hot well; and L^1 are pipes by which the condensation water from the calandrias B of the pans A^1 and A^2 is delivered to the distilled-water receiver. L^2 is a pipe for removing the excess of vapour from the calandria B of the third pan A^2 .

The vacuums maintained in the three vessels or effects A, A^1 , A^2 will be respectively about 4 in., 14 in., and 24 in., and the temperatures, taking the vessels or effects in the like order, will be about 200°, 180°, and 130° Fahr.

It will be seen that the economy of the triple-effect apparatus is due to the fact of its being largely self-heating, as the calandria of the first vessel or effect is the only one heated by extraneous means, the calandria of the second effect being heated by the latent heat of the steam or vapour from the boiling water in the first effect, and the third effect being heated from that of the second effect. Thus, neglecting the loss of heat due to radiation, a double effect is twice, and a triple effect is three times, as economical in steam consumption for heating purposes as a single effect.

The Haslam distilling apparatus is constructed upon the triple-effect principle, and comprises a first boiling pan, a second boiling pan, a condenser, a feed-water heater, and a distilled-water receiving tank or vessel. When no exhaust or waste steam is available the plant also includes a suitable steam boiler.

Fig. 368 is a perspective view, partly in section, illustrating a complete single-effect distilling apparatus of the Yaryan type, which is made in various sizes, adapted to produce from 3 tons to 48 tons of distilled water per twenty-four hours. The apparatus consists essentially of a cylindrical evaporator, having a horizontal body or shell of wrought iron, with a separator similarly constructed at one end, and a number of straight, solid-drawn tubes (according to the capacity of the machine) so fixed in tube plates provided at both ends of the shell or body as to be capable of being readily withdrawn when necessary for cleaning purposes. These tubes are connected at their ends by return heads, so as to throw them into sets or series, thus practically forming coils of pipe of any desired length. The water to be distilled is passed through these coils or sets of pipes, the exhaust steam being admitted to the space round them, and the steam or vapour from the evaporating coils passes through the separating chamber, which is fitted with baffle or check plates, one of which is

shown in the drawing, to the condenser, which latter also forms an interchanger and heats the water to be distilled.

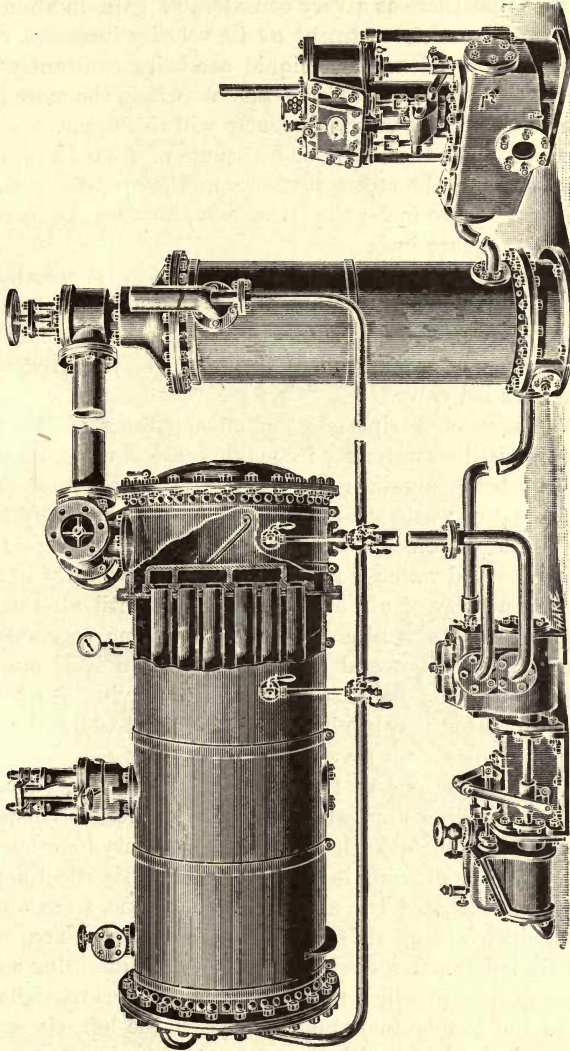

Fig. 368. — Complete Single-Effect Distilling Apparatus on the Yaryan System.

The distinctive feature of this system is film evaporation, that is, the blowing of the whole mass of the liquid to be evaporated into spray,

and its rapid motion through the sets or series of tubes during the process. This latter point is of great importance, and is the chief reason of the great efficiency of this type of apparatus. The result is due to the fact that there is a very considerable gain in absorption of heat by the liquid under treatment as its velocity increases, owing to the fact that new particles of the liquid are being constantly brought into contact with the heated surfaces, and naturally the more rapid its motion over the latter the more frequently will this occur.

When in operation there will be a vacuum of from 12 in. to 15 in. in the separator, and the steam pressure in the evaporator should be about 15 lbs. per square inch; the latter may, however, be increased to about 40 lbs. per square inch.

The feed taken from the circulating discharge is usually drawn into the tubes by reason of the vacuum in the separator. If, however, condensation is carried out at atmospheric pressure, it is forced in owing to the head of water due to the height of the circulating discharge or to a loaded valve.

The advantages of a triple-effect or an apparatus of this type for producing pure distilled water for ice-making, are obvious, inasmuch as it admits of its being obtained free from the slightest trace of oil by the use of exhaust or waste steam only, and that without any necessity for filtering. The dispensing with filtering is of some importance, as each time the distilled water is passed through a new filter it takes up a considerable quantity of air, and consequently until all the air has become expelled from the filter the water is in no way superior to ordinary undistilled water, and the ice made from it is opaque and porous. The condensed exhaust steam, after having performed its duty in the evaporator, may be either run into a hot-well to be used for boiler-feeding purposes, or it may be run to waste.

Fig. 369 illustrates one of the Mirrlees, Watson, & Yaryan Co.'s larger forms of distilling apparatus, which is suitable for installations turning out considerable quantities of ice per twenty-four hours. As will be seen from the drawing it is a sextuple or six-effect apparatus. On the right are situated the air, circulating, brine, fresh water, and feed pumps, which are all driven off one engine, and are, with the latter, the only moving parts. Next is placed the distilling condenser (between two heaters in which the feed-water becomes partially heated on its way to the evaporator); and, finally, on the left, six separators placed in a vertical column, with the corresponding six effects arranged horizontally in the rear.

In operation there will be a pressure of from 40 to 60 lbs. in the

first effect, and a vacuum of about 27 in. in the distilling condenser, the apparatus being so proportioned that this difference of pressure will distribute itself automatically between the several effects. The

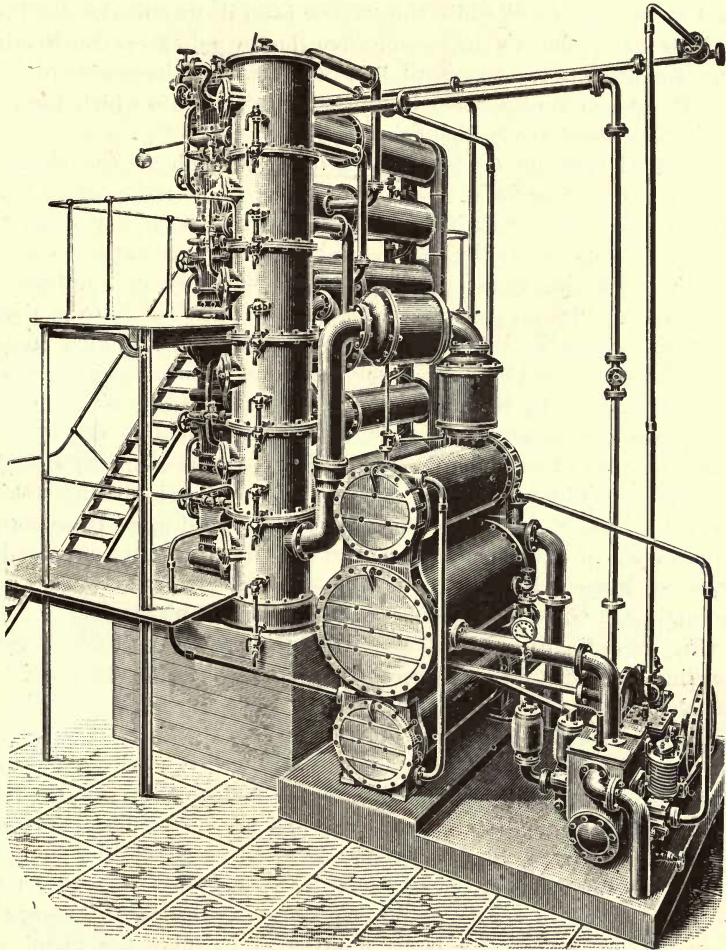

Fig. 369.—Complete Sextuple-Effect Distilling Apparatus on the Yaryan System.

feed for the evaporator being taken from the circulating water of the distilling condenser, a certain amount of heat, which would otherwise be rejected, is utilised at the very commencement of the operation,

and the efficiency of the apparatus is further increased and heat economised by a multiple-effect system of heating the feed before reaching the evaporating vessel. The first stage of heating the feed referred to is effected by exposing it to the vapour given off by the water evaporated in the last effect while this vapour is on its way to the distilling condenser, and then to the vapour from the several effects constituting the evaporating apparatus, until it receives its final increment of heat from the steam employed to heat the first effect, into which the feed enters at or about the boiling-point of that effect.

The feed entering the first, passes down through all the effects of the apparatus. The water resulting from the condensation which takes place on the different heating surfaces, together with that from the last effect, being eventually delivered as cold distilled water. Usually the water resulting from the condensation of the steam employed to heat the first effect is separated from that produced in the remainder of the apparatus, as being likely to be slightly contaminated, and is reserved for feeding the boiler supplying steam to the apparatus, pumping engines, &c. In the number of effects used in combination with the system of evaporating water in continuous motion depends the great economy of fuel which is obtained in apparatus of this type. The only labour required in connection with the apparatus is that for stoking the boilers, and the necessary attention to the feeding of these and to the working of the pumps. All parts of the apparatus are readily accessible, hinged doors at the end of each effect giving easy access to the interior of these for cleaning purposes when required.

An exceedingly compact and efficient form of portable Yaryan distilling apparatus has also been designed by the same firm, which is entirely self-contained and is easily movable, being mounted upon an independent carriage supported upon strong iron wheels. The apparatus comprises two Yaryan evaporators arranged to work as a double effect, a distilling condenser in connection therewith, a suitable feed-water tank, a pump for feeding the water to be distilled through a heater into the first effect or vessel, and a tail or circulating pump for condensing the steam given off from the second effect or vessel in the distilling condenser. The steam required for working the apparatus is supplied from a portable boiler fitted with a donkey feed-pump, &c., and also mounted upon iron road wheels.

The advantages of a portable distilling apparatus capable of being shifted with great facility from one source of water supply to another, or to any desired location in the works, are obvious. And the compactness of the installation renders it very easily manageable, one

skilled attendant and a boy being sufficient for a machine having a capacity to produce 85 gals. of pure fresh water per hour from strong brine averaging twice the density of ordinary sea water. Exhaustive tests proved most conclusively that the efficiency of the plant was fully equal at the termination of each run to what it was at the commencement, which abundantly demonstrated the self-cleaning powers of the apparatus when treating water so strongly charged with salts. The evaporative duty was $4\frac{3}{4}$ lbs. of water per pound of common wood fuel; with coal, however, the duty would be about double per pound of coal consumed, and naturally when treating impure water of less density than the brine, or comparatively pure water for de-aerating purposes, the amount of pure de-aerated water obtained per pound of fuel consumed would be proportionately larger.

In the case of a single-effect distilling apparatus the above fuel consumption would be doubled to produce the same amount of distilled water, and the more effects that are employed up to a certain point the greater the economy, a six-effect apparatus being found capable of producing 36 lbs. of pure distilled water for each pound of fuel consumed, that amount being over and above what was evaporated in the boiler which was returned to the latter.

It is obviously, therefore, advisable, wherever the demand for the de-aerated water warrants it, to employ a multiple-effect distilling apparatus.*

In most factories however, the exhaust steam from the engines will be available for use in the apparatus, and the expenditure on fuel for raising steam, specially for use in the evaporator, will thus be saved.

The evaporator should be opened every two or three weeks, and if scale is found on any of the tubes, these should be withdrawn and clean ones inserted in their place. The best means to employ for removing the scale from the tubes is to pass them over a slow fire, care, however, being taken not to apply more heat than is necessary to bring off the scale.

VACUUM SYSTEM OF ICE-MAKING.

The method of making ice without the use of either a primary or secondary cooling agent, that is to say, by freezing the water in vacuo, has been already dealt with when describing the Carré, Wind-

* A detailed description of the larger forms of multiple-effect Yaryan evaporator with reference to their use for the evaporation and concentration of saccharine juices and solutions, will be found in a treatise on "Sugar Machinery" by the same author.

hausen, Harrison, and other vacuum machines. Briefly, the principle upon which they work is that if water be exposed in a practically perfect vacuum it is rapidly turned into vapour, and this change requiring a large quantity of heat which must be provided by the water itself, that portion of the water which is not vaporised becomes frozen solid. As already mentioned, however, the ice thus made is more in the form of granulated snow, and, being brittle, charged with air, and possessing no durability, it is practically of very little or no market value.

IMITATION OF NATURAL SYSTEM.

In another system, wherein an imitation of the natural process is attempted, the water to be frozen is exposed in well-insulated rooms or chambers to a temperature far below freezing-point. This plan, however, is not found to answer commercially owing to the extreme slowness with which the freezing or congealing of the water is effected, by reason of the low specific heat of air and its poor capacity for conduction, a fault which cannot be got over even by increasing the cooling surfaces of the rooms to an abnormal degree.

ICE FACTORIES.

A factory for making ice consists of more or less solid buildings in accordance with the particular regulations of the locality, capital at command, &c. Fig. 370 shows an arrangement of the ice-tank or box-room, but in addition to this the factory will comprise a machine-room, boiler-room, ice store, offices, loading platforms, &c.

The arrangement shown in the drawing is intended for making ice on the can system, and the ice-boxes are precisely similar to those previously described. Above the ice-boxes is provided a travelling hoist or crane, by means of which the cans or moulds can be conveniently raised one by one from the ice-boxes, when the water in the cans has been frozen, and transferred to the platform shown on the right-hand side of the drawing. On or beneath this platform are provided a suitable number of thawing or relieving tanks filled with warm or tepid water at about 70° Fahr., and into this the can or mould is dipped for a few seconds, after which the block of ice can be readily turned out on a tip-table, and the can or mould is again filled with water and returned into the brine-tank to recommence freezing. The ice blocks or cakes are in some instances turned out of the cans or moulds at, or delivered to, the upper end of an inclined plane or runway, down which they pass to the ice-store, or ante-chamber

leading thereto. The waste-water tanks, &c., are located beneath the ice-making tanks or boxes.

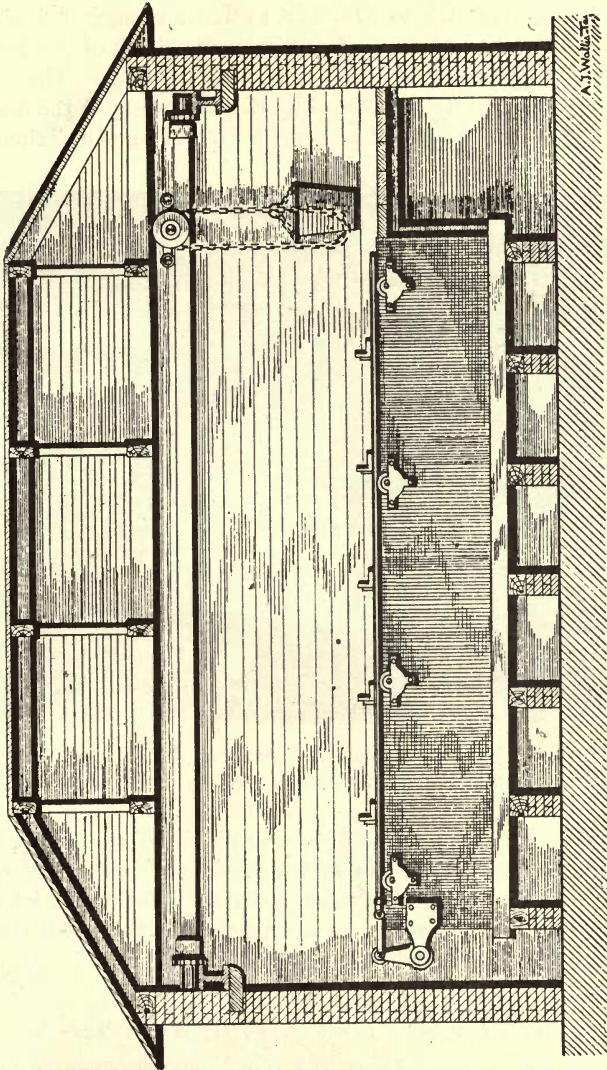

Fig. 370.—Ice-Tank or Box-room of Ice Factory on the Can System. Sectional Elevation.

Fig. 371 shows the arrangement of an ice-tank or box-room of an ice factory for making ice on the plate or wall system, designed by the

Pulsometer Engineering Co., Ltd. The mechanism for raising the slabs or blocks of ice from the ice-tanks or boxes is clearly shown in this illustration.

Figs. 372 to 374, 375 to 377, 378 to 380 are suggested plans by the Frick Company for can-ice factories, respectively of the following capacities: 6 to 10 tons, 30 to 35 tons, and 100 tons. The arrangement of these factories is explained by the writing upon the drawings. Figs. 381 and 382 is a plan of a model ice factory by the Triumph Ice

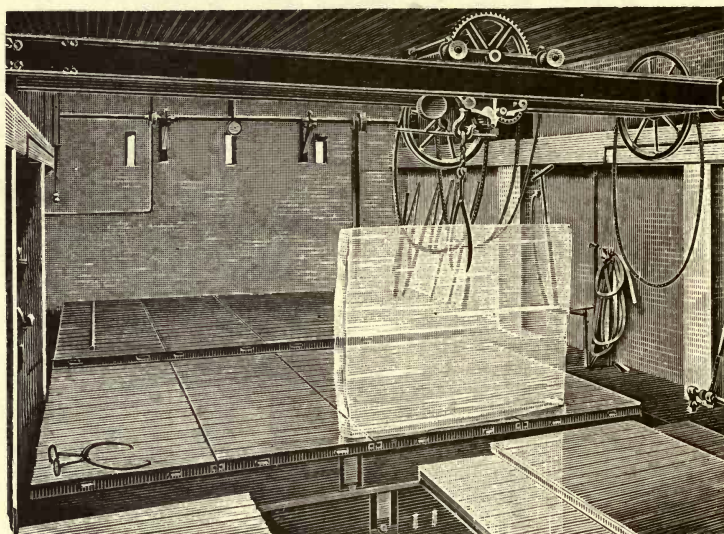
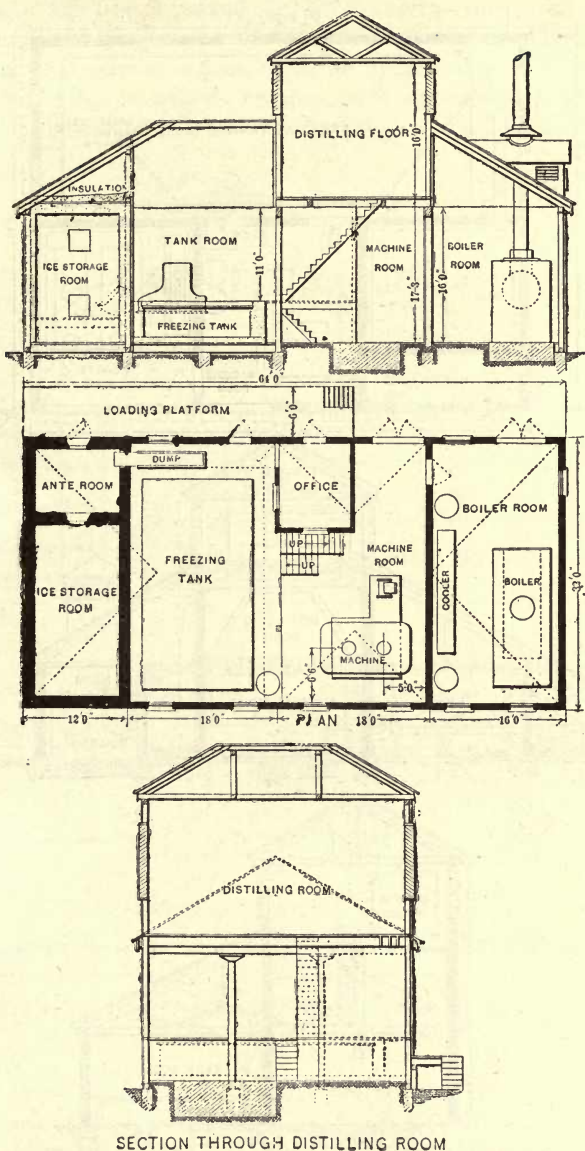

Fig. 371.—Ice-Tank or Box-room of Ice Factory on the Plate or Wall System, showing Mechanism for Raising Slabs or Blocks of Ice.

Machine Co. Figs. 383 and 384 show in plan and sectional elevation a 5-ton ice factory on the can system, designed by the Vulcan Iron Works. And Fig. 385 is a sectional elevation showing an ice factory on the "Eclipse" can system as constructed by the Frick Company. These three drawings are also self-explanatory.

ICE ELEVATING AND CONVEYING MACHINERY.

As has been already mentioned, numerous contrivances for minimising the work of handling the cans or moulds and the blocks of ice have been devised.



SECTION THROUGH DISTILLING ROOM

Figs. 372 to 374.—Frick Company Arrangement for Ice Factory of 6 to 10 Tons Capacity. Plan, Sectional Side Elevation, and Transverse Section.

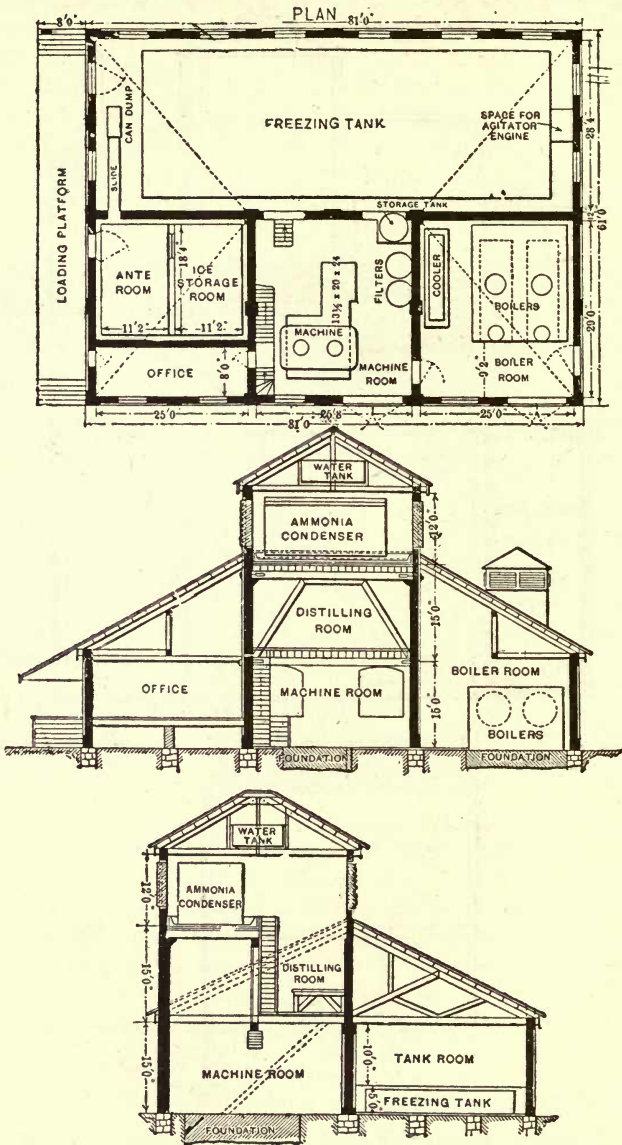

Figs. 375 to 377.—Frick Company Arrangement for Ice Factory of 30 to 35 Tons Capacity. Sectional Side and End Elevations and Plan.

Puplett and Rigg's patent of 1887 comprises an arrangement for facilitating the lifting of the cans or cases, and removing the ice. This labour-saving contrivance consists in an apparatus for connecting two or more of the cans, moulds, or cases together, and comprises a frame which is provided with trunnions or gudgeons, so situated as to be

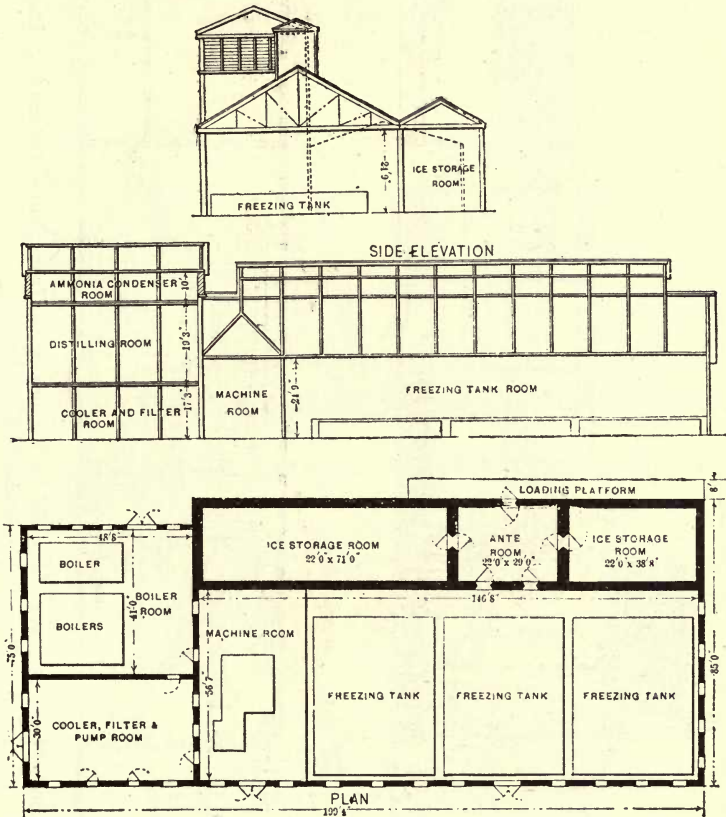

Figs. 378 to 380.—Frick Company Arrangement for Ice Factory of 100 Tons Capacity. Plan and Sectional Side and End Elevations.

slightly above the centre of gravity of the cans or moulds. At one end of each of these frames a quadrant, worm and worm-wheel, or some other convenient means are provided for enabling the frame and moulds therein to be inclined to any required angle. To admit of the frames being raised from the ice-making tank or box by the overhead

traveller the latter is fitted with links adapted to engage with the above-mentioned trunnions or gudgeons. The frame and moulds or

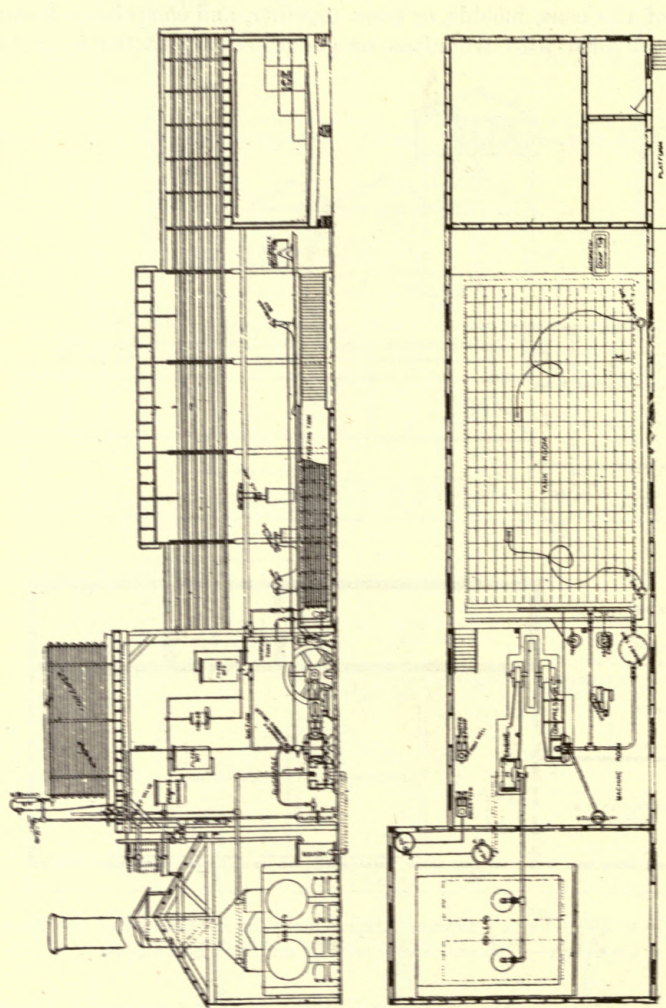

Figs. 381 and 382.—Arrangement of Model Ice Factory by the Triumph Ice Machine Co. Plan and Sectional Elevation.

cans being nearly balanced on their trunnions, the labour of discharging the ice therefrom is greatly reduced, and the operation is moreover considerably expedited. The quadrant or worm gearing is usually

so arranged as to engage with a suitable device fixed on to the links of the overhead traveller; but mechanical contrivances can be dispensed with and the frame containing the moulds tipped by hand, which operation, owing, as above-mentioned, to its being almost balanced, can be so accomplished without any difficulty.

Fig. 386 is a truck ice-can hoist for use with very small ice-making plants. Fig. 387 is a travelling crane, and geared hand-power ice-can

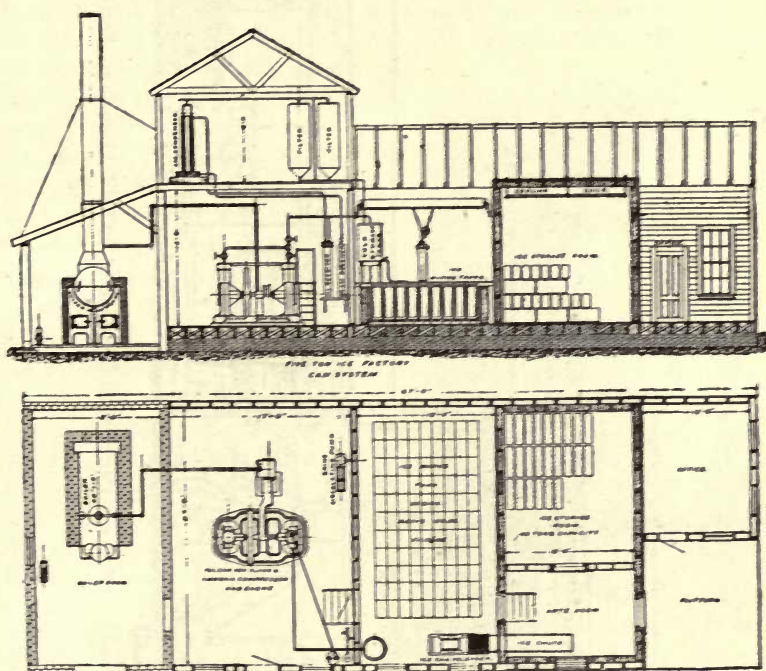

Figs. 383 and 384.—Vulcan Iron Works Arrangement for a 5-ton Ice Factory on the Can System. Plan and Sectional Elevation.

hoist by means of which one man whilst on watch can take care of from ten to fifteen cans per hour. And Fig. 388 is an electric crane for use in connection with large installations, and which is capable of handling any desired number of cans. The above appliance is constructed by the Frick Company.

Fig. 389 represents an automatic ice-dump made by the Triumph Ice Machine Co. The box is made of $\frac{3}{16}$ -in. steel, reinforced by

$\frac{3}{8}$ in. by $\frac{1}{2}$ in. iron. The valve and shaft are bolted on this box with a heavy flange. The stands carry the bearings and box, and are bolted to a cast-iron waste box, there being no wood about the box to decay or give way.

The operation of this dump is as follows, viz. :—The box being in a vertical position to receive the can, the small lever at the bottom can be operated by the foot so as to give the dump a slight tilt toward the front, when the dump will go over slowly and turn on the warm water automatically, while same is turning down in position to dump the ice. The water strikes all sides and under the can. The valves are so regulated that the bottom of the can will receive the most water, thereby melting the ice away from that part. The weight of the ice starting, the cake will then fall on the bottom of the can, and the air will rush in over the top of the ice, forcing same out of the can.

Fig. 390 shows the Vulcan Iron Works track system. The rail in this arrangement is supported during the throw of the switches, so that no abnormal strain can come upon the hinge or joint, and the latter cannot be broken off if the switch be left open. The rail is formed of $2\frac{1}{2}$ in. by $\frac{1}{2}$ in. iron, and the hangers are so constructed that any portion of the rail can be secured to the hanger without drilling.

These switches are made two, three, and four throw.

Ice-delivery machines and other labour-saving appliances are also manufactured by the Pulsometer Engineering Co., Ltd., and others.

Whatever the arrangement, however, for drawing the ice, one thing is absolutely necessary to ensure economical working, and that is the strictest regularity. It is, of course, understood that the machinery should also be kept working at as uniform a speed as possible, and that all temperatures should be maintained as normal as practicable.

Suitable ice elevators or hoists are also required for raising the blocks of ice from one level of the factory to another. Amongst numerous devices for this purpose, mention may be made of the

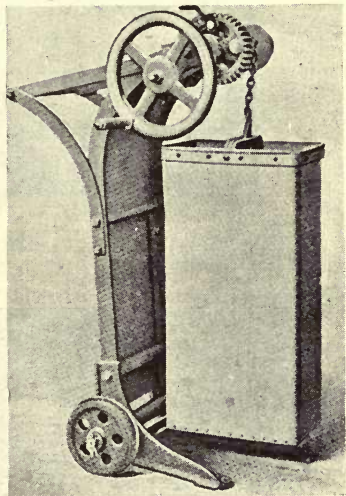

Fig. 386.—Frick Ice-Can Hoist for use with Small Ice-making Plants.

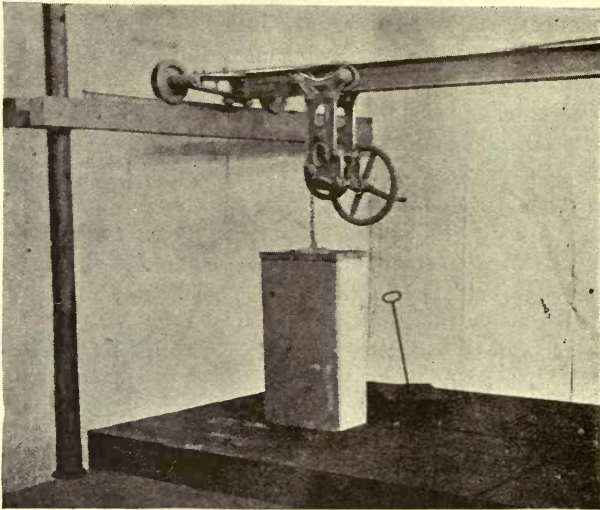

Fig. 387.—Travelling Crane and Geared Hand-power Ice-Can Hoist.

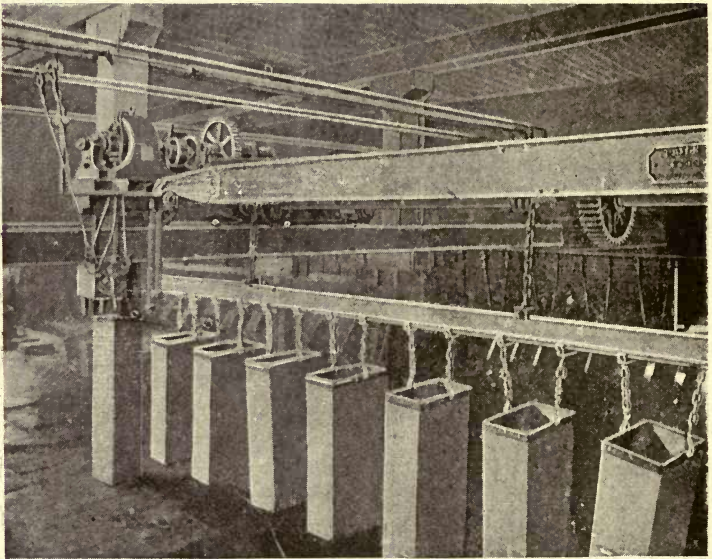

Fig. 388.—Electric Crane for Handling Ice Cans in Large Factories.

following, viz., that wherein an endless chain, provided with hooks, is employed to grab the blocks of ice, and drag them up an incline, which latter may be made in sections, so as to admit of the ice being discharged at different elevations. The hooks are set in position to engage with the blocks of ice by a spring bar upon the frame carrying the driving-wheel. In another arrangement the blocks of ice are shoved up a fixed spiral incline, by arms or levers projecting radially from a shaft, located vertically in the centre of the incline, and rotated in any convenient manner.

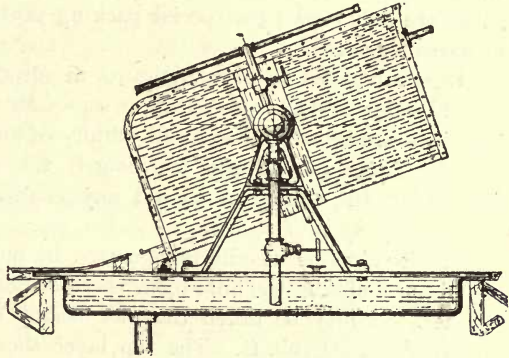

Fig. 389.—Automatic Ice Dump.

Ordinary hydraulic or steam platform lifts, communicating between the different floors of the factory, may be located wherever found to be

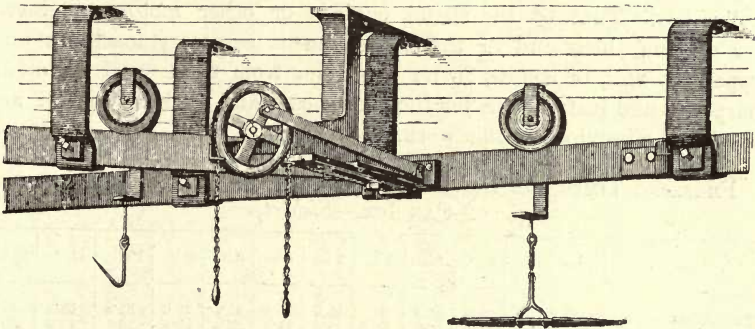

Fig. 390 —Vulcan Iron Works Track System.

necessary and convenient, as also run-ways or slip-ways and gravity hoists.

A number of loose tools are likewise required in an ice factory for manipulating the ice, such as ice-saws, hatchets, hooks and picks hoisting tongs, trollies, &c.

ICE-MAKING, GENERAL.

Cube Ice.—An arrangement invented by Mr Van der Weyde for cutting ice into small blocks or cubes comprises circular saws and endless conveying bands or belts, by means of which the cut blocks or cubes are delivered to a special packing table, where they are stowed in boxes for delivery.

It is advisable to have hydrants in suitable positions throughout the buildings, and this precaution is especially desirable where ammonia machines are in use, the extreme affinity of ammonia for water rendering the latter (as already mentioned) the best remedy to employ for killing the ammonia should any considerable quantity become accidentally spilt.

The ice store is usually refrigerated by means of a brine or direct expansion coil, and the ante-room thereto should be cooled in a similar manner. It may be taken that, as usually stored, a ton of ice will occupy about 50 cub. ft. The top layer should be covered with dry sawdust or shavings. See also "Storing Ice."

In some places it is found advisable and advantageous to add to the ice factory buildings one or more cold stores or chambers, wherein perishable products can be preserved for customers desiring such accommodation.

The management of ice-making and refrigerating machines will be found dealt with in the next chapter, so far as the space at command will allow. That of the steam engines or other motors employed for driving these and of the miscellaneous accessory machines and apparatus will, of course, in no way differ from those used for other purposes, and instructions for the proper care and working thereof are outside the province of this work.*

FREEZING TIMES FOR DIFFERENT TEMPERATURES AND THICKNESSES OF CAN ICE.—*Siebert.*

| Thickness. | 1 in. | 2 in. | 3 in. | 4 in. | 5 in. | 6 in. | 7 in. | 8 in. | 9 in. | 10 in. | 11 | 12 in. |
|-----------------|-------|-------|-------|-------|-------|-------|-------|-------|-------|--------|------|--------|
| Temperature 10° | 0·32 | 1·28 | 2·86 | 5·10 | 8 | 11·5 | 15·6 | 20·4 | 25·8 | 31·8 | 38·5 | 45·8 |
| " 12° | 0·35 | 1·40 | 3·15 | 5·60 | 8·75 | 12·6 | 17·3 | 22·4 | 28·4 | 35 | 42·3 | 50 |
| " 14° | 0·39 | 1·56 | 3·50 | 6·22 | 9·70 | 14 | 19 | 25 | 31·5 | 39 | 47·0 | 56 |
| " 16° | 0·44 | 1·75 | 3·94 | 7 | 11 | 15·8 | 21·5 | 28 | 35·5 | 43·7 | 53·0 | 63 |
| " 18° | 0·50 | 2 | 4·50 | 8 | 12·5 | 18 | 24·5 | 32 | 40·5 | 50 | 60·5 | 72 |
| " 20° | 0·57 | 2·32 | 5·25 | 9·30 | 14·6 | 21 | 28·5 | 37·3 | 47·2 | 58·3 | 70·5 | 84 |
| " 22° | 0·70 | 2·80 | 6·30 | 11·2 | 17·5 | 25·2 | 34·3 | 44·8 | 56·7 | 70 | 84·7 | 100 |
| " 24° | 0·88 | 3·50 | 7·86 | 14 | 21 | 31·5 | 42·8 | 56 | 71 | 87·5 | 106 | 126 |

* For detailed information regarding friction and the management and lubrication of the rubbing parts of machinery see "Bearings and Lubrication," by the same author.

TIME REQUIRED FOR WATER TO FREEZE IN ICE CANS.

(The Triumph Ice Machine Co. Catalogue).

| Size of Cans. | Weight of Cake. | Time to Freeze. |
|---------------------------|-----------------|-----------------|
| 6 in. by 12 in. by 24 in. | 50 lbs. | 20 hours |
| 8 " 18 " 32 " | 100 " | 36 " |
| 8 " 16 " 40 " | 150 " | 36 " |
| 11 " 22 " 32 " | 200 " | 55 " |
| 11 " 22 " 44 " | 300 " | 60 " |
| 11 " 22 " 57 " | 400 " | 60 " |

NOTE.—Temperature of bath 14° to 18° Fahr. As a rule, the higher the bath temperature the slower the process of freezing, but the finer and clearer the ice.

TABLE OF ICE-PLANT EFFICIENCIES COLLECTED FROM TWENTY-SEVEN EXISTING AND OPERATING PLANTS.—*Sneddon.*

| Ice Produced in Tons per 24 hours. | Coal Consumed in lbs. per 24 Hours. | Lbs. of Water Evaporated to 100 lbs. G Pressure from 212° per 24 Hours (or Max. Ice Production). | Lbs. of Water Evaporated per lb. of Coal (or lbs. of Ice Made). | B.T.U. contained in 1 lb. of Coal (Calculated). | Total Heat put into Total Water Evaporated by 1 lb. of Coal. | Efficiency per Cent. | Loss on 70 Basis per Cent. |
|------------------------------------|-------------------------------------|--|---|---|--|----------------------|----------------------------|
| 5.4 | 4,800 | 10,800 | 2.25 | 13,400 | 2,261 | 17.6 | 75 |
| 5.7 | 4,800 | 11,400 | 2.37 | 13,400 | 2,381 | 17.7 | 74.8 |
| 7.25 | 4,000 | 14,500 | 3.62 | 12,200 | 3,638 | 29.8 | 57.5 |
| 7.5 | 4,000 | 15,000 | 3.75 | 12,200 | 3,768 | 30.8 | 56 |
| 10.33 | 5,000 | 20,660 | 4.13 | 14,858 | 4,150 | 27.9 | 60.2 |
| 11 | 5,000 | 22,000 | 3.93 | 14,858 | 3,949 | 19.9 | 71.6 |
| 14 | 12,000 | 28,000 | 2.33 | 12,700 | 2,341 | 18.4 | 74.3 |
| 14.5 | 9,000 | 29,000 | 3.22 | 11,900 | 3,236 | 27.2 | 61.2 |
| 16.5 | 9,500 | 33,000 | 3.47 | 11,900 | 3,488 | 29.3 | 58 |
| 15.6 | 9,600 | 31,200 | 3.25 | 12,300 | 3,266 | 26.5 | 62.2 |
| 16.5 | 11,200 | 33,000 | 2.94 | 12,300 | 2,945 | 24 | 65.8 |
| 20 | 12,000 | 40,000 | 3.33 | 12,600 | 3,346 | 26.5 | 62.2 |
| 19 | 8,000 | 38,000 | 4.75 | 12,200 | 4,773 | 39.1 | 44.2 |
| 14.5 | 6,000 | 29,000 | 4.83 | 12,200 | 4,854 | 39.8 | 43.2 |
| 17.5 | 10,000 | 35,000 | 3.5 | 12,000 | 3,517 | 29.3 | 58 |
| 17.66 | 10,000 | 35,320 | 3.53 | 12,600 | 3,547 | 28.1 | 60 |
| 27.5 | 13,500 | 55,000 | 4.07 | 13,000 | 4,090 | 31.3 | 55.3 |
| 19 | 7,000 | 38,000 | 5.42 | 12,200 | 5,447 | 44.6 | 36.3 |
| 20 | 6,000 | 40,000 | 6.66 | 13,000 | 6,693 | 51.4 | 26.6 |
| 23 | 6,800 | 46,000 | 6.76 | 13,000 | 6,793 | 52.2 | 25.5 |
| 24 | 7,000 | 48,000 | 6.85 | 13,000 | 6,884 | 53 | 25.8 |
| 29 | 14,000 | 58,000 | 4.14 | 12,000 | 4,160 | 34.6 | 50.6 |
| 25 | 18,000 | 50,000 | 2.77 | 12,000 | 2,783 | 23.2 | 66.9 |
| 32 | 22,000 | 64,000 | 2.90 | 12,000 | 3,045 | 25.3 | 62.9 |
| 31 | 14,000 | 62,000 | 4.42 | 10,500 | 4,442 | 42.2 | 39.8 |
| 82 | 22,500 | 164,000 | 7.28 | 13,100 | 7,286 | 55.6 | 20.6 |
| 85 | 20,740 | 170,000 | 8.22 | 13,100 | 8,261 | 63.0 | 10 |

TABLE GIVING SIZES AND CAPACITIES OF VARIOUS ICE-MAKING PLANTS.

H. H. Kelly, "The Engineer," New York.

| Tons* per Twenty- four Hours. | Size of Engine. | Revolu- tions. | Size of Com- pressor. | Size of Blocks of Ice. | Gallons of Water per Hour. | Tons of Coal. | No. of Engineers. | No. of Firemen. | No. of Labourers. |
|---|--------------------|-------------------|-----------------------------|----------------------------------|----------------------------------|------------------|----------------------|--------------------|----------------------|
| 1 | 7 by 9 | 90 | †5 by 10 | 8 by 8 by 28 | 5 | $\frac{1}{2}$ | 1 | - | - |
| 3 | 8 ,, 16 | 80 | 5 ,, 15 | 8 ,, 15 ,, 28 | 15 | 1 $\frac{1}{2}$ | 2 | 2 | 2 |
| 5 | 10 ,, 20 | 75 | 6 ,, 18 | 11 ,, 15 ,, 28 | 20 | 1 $\frac{1}{2}$ | 2 | 2 | 2 |
| 10 | 12 ,, 30 | 70 | 8 ,, 20 | 11 ,, 22 ,, 28 11 ,, 11 ,, 28 | 30 | 2 | 2 | 2 | 3 |
| 10 $\frac{1}{2}$ | 14 ,, 30 | 65 | 8 ,, 25 | 11 ,, 22 ,, 28 11 ,, 11 ,, 28 | 35 | 2 $\frac{1}{2}$ | 2 | 2 | 3 |
| 15 | 14 ,, 30 | 65 | 10 ,, 20 | 11 ,, 22 ,, 28 11 ,, 11 ,, 28 | 40 | 3 | 2 | 2 | 4 |
| 20 | 16 ,, 30 | 55 | 10 ,, 30 | 11 ,, 22 ,, 28 11 ,, 11 ,, 28 | 50 | 4 | 2 | 2 | 5 |
| 30 | 16 ,, 42 | 52 | 11 ,, 30 | 11 ,, 22 ,, 28 11 ,, 11 ,, 28 | 60 | 5 | 2 | 2 | 6 |
| 40 | 18 ,, 36 | 50 | 12 ,, 30 | 11 ,, 11 ,, 28 | 90 | 6 $\frac{1}{2}$ | 2 | 2 | 7 |
| 45 | 20 ,, 36 | 50 | 15 ,, 30 | 11 ,, 11 ,, 28 | 94 | 8 | 2 | 2 | 8 |
| 60 | 24 ,, 36 | 45 | 16 ,, 36 | 11 ,, 11 ,, 28 | 96 | 10 | 2 | 2 | 9 |
| 80 | 26 ,, 48 | 45 | 20 ,, 36 | 11 ,, 22 ,, 28 | 100 | 14 | 2 | 2 | 10 |

* 2,000 lbs.

† One cylinder.

BRINE FOR USE IN REFRIGERATING AND ICE-MAKING PLANTS.

A brine suitable for the above purpose can be made with from 3 to 5 lbs. of chloride of calcium, or muriate of lime, in accordance with its degree of purity, dissolved in each gallon of water. The density of this solution is about 23° Beaumé, its weight about 13 $\frac{1}{2}$ lbs. per gallon, and the freezing point is - 9° Fahr. As the above standard of density must be kept up, in order to prevent the brine from becoming congealed in the refrigerator or the ice-making tanks or boxes, it is desirable to test it periodically with a salinometer.

In the best American practice first quality medium-ground salt, preferably in bags for convenience of handling, is employed, the proportions being about 3 lbs. of salt to each gallon of water. The brine is made in a brine mixer, such as that shown in Fig. 391, which consists of a water-tight box or tank A, about 4 ft. by 8 ft. by 2 ft., having a suitably perforated false bottom B, and a small compartment C, partitioned off at one extremity, communicating with the main compartment through an overflow D, situated at the upper end of the partition, and fitted with a large strainer to prevent the passage into

the small compartment of salt or foreign bodies. The water is admitted through a pipe *E*, which extends into the tank *A*, and runs the full length of the false bottom, the latter portion being perforated, as shown, and the brine is removed through a pipe *F* from the upper part of the end compartment, at the lower extremity of which latter pipe is a strainer-box and strainer through which the brine passes before delivery into the brine-tank. A salt gauge, salinometer, or hydrometer is also placed in this end compartment. The sketch shown is from one given in the New York *Engineer*.

The salt should be dissolved in the water until it reaches a density of about 90° by the hydrometer. To facilitate dissolution it is desirable to stir the salt in the mixer with some handy implement, the salt being shovelled in as fast as it can be got to dissolve.

By the use of this mixer the settlement of salt on the bottom and

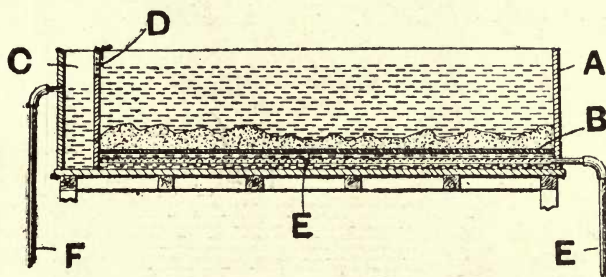

FIG. 391.—Brine Mixing Tank. Vertical Longitudinal Central Section.

on the coils in the brine tank, which inevitably results when the solution is effected directly in the latter, is avoided.

To maintain the strength of the brine it is recommended to suspend bags filled with salt in the brine-tank, or to pass the return brine through the above-described brine maker or mixer.

A cheap and easily constructed apparatus for mixing brine can be made out of an old barrel in which a perforated false bottom is fixed a short distance above the bottom, the water to form the solution being delivered to the space between the two bottoms, and an overflow pipe, fitted with a suitable strainer and a well to receive a salinometer, being provided near the top to draw off the brine.

When the temperature falls below 7° below zero Fahr. chloride of calcium must be employed, as a solution of common salt can only be reduced to a temperature 7° below zero, whilst chloride of calcium can be cooled down to 39° below zero Fahr.

Fig. 392 illustrates a brine concentrator of the Haslam type. The apparatus comprises a steam-jacketed pan, known as the concentrator, a series of tubes known as the interchanger, and a brine pump. The operation of the apparatus is as follows:—Brine is drawn from the battery by the pump, forced through the interchanger, and delivered

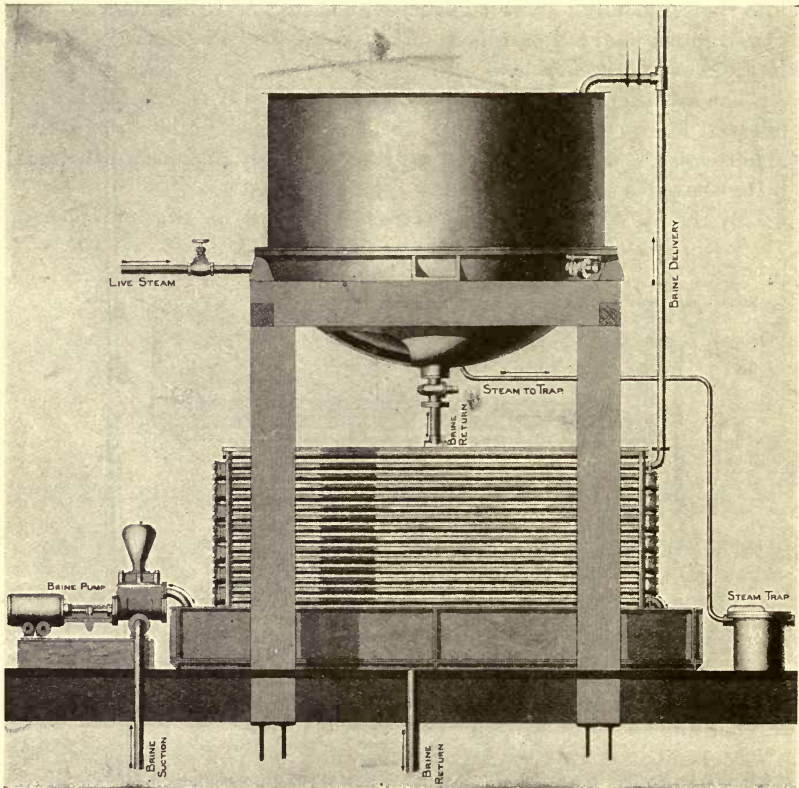

Fig. 392.—Haslam Brine Concentrator.

into the concentrator. Here it is reduced by heat to the right specific gravity, after which it is allowed to flow back over the interchanger into the battery. In passing over the interchanger, it is cooled by the incoming brine flowing through the interchanger, and in turn heats the incoming brine, thus saving both steam and work on the refrigerating machine.

STORING, HANDLING, AND SELLING ICE.

For storing purposes ice should be clear, solid, and devoid of core. In America some persons insist that ice for storage should not be made at temperatures higher than 10° to 14° in brine-tank.

The first requisite for a storage house for artificial ice, as also for natural ice, is, of course, the best possible insulation; other necessary points to be attended to are drainage and ventilation. The best shape for an ice-storage house is square, or as nearly approaching this form as possible, and the roof should have a good pitch. An ante-room or lobby is also desirable, as by the provision of this latter the necessity for the frequent opening of the main store is done away with.

To preserve the ice, the storage rooms, as well as the ante-chambers or lobbies must be refrigerated, and the amount of the latter required may be roughly estimated, according to Prof. Siebel, at from about 10 to 16 British thermal units of refrigeration per cubic feet contents for twenty-four hours. About 1 ft. of 2-in. pipe (or its equivalent in other size pipe) per 14 to 20 cub. ft. of space is frequently allowed, says the same gentleman, in ice-storage houses for direct expansion, and about one-half to one-third more for brine circulation. The pipes should be located on the ceiling of the ice-storage house.

The ventilation of an ice-storage house should be carefully attended to, and ventilators fitted with suitable regulators should be provided both in the highest part of the roof and also in the gable ends. The drainage should be such as to absolutely prevent the accumulation of any moisture beneath the bed of ice. It is recommended to paint an ice store white, preferably with a mineral such as barytes or patent white.

Respecting the best method to adopt for packing the ice in the store considerable diversity of opinion seems to exist. It is well to provide a bed of from 18 in. to 2 ft. of cinders, as this tends to improve the drainage of the house. In one method the blocks are placed on edge and as closely packed together as possible, the blocks in each succeeding layer being placed exactly over those beneath and all breaking of joints being avoided. The ice is covered between the times of storing with dry sawdust or soft wood shavings, and the uppermost layer is invariably covered with dry sawdust or shavings.

Mr R. Thompson, writing to the Canadian *Farming World*, says that in filling the house he places the ice on edge, placing every alternate layer crossways, which plan, he claims, enables ice to keep better and come out easier.

Others recommend that the ice be stored with alternate ends touching and alternately from $1\frac{1}{2}$ to 2 in. apart, so as to prevent the ice from freezing together. The cakes or slabs of ice should not be parallel to each other, and storage should only be made when the temperature is at or below freezing. Or, again, $\frac{1}{2}$ -in. strips placed between the layers of ice in the store so as to separate the cakes or blocks, top, side, and bottom, from all others in the house.

For packing the ice, sawdust, rice chaff, straw, hay—marsh or prairie hay being said to be preferable—are employed. Of these materials hay is the best, rice chaff is capable of being dried and re-used. 6 in. of well-packed hay should be placed between the ice and the walls, and no covering until the store is full.

1 cub. ft. of ice is taken to weigh 57.5 lbs. approximately at 32° Fahr. 1 cub. ft. of water frozen at 32° will make 1.0855 cub. ft. of ice, thus showing an expansion of 8.5 per cent. due to freezing. 1 cub. ft. of pure water at 39° Fahr., its point of greatest density, weighs 62.43 lbs. 50 cub. ft. of ice, as usually stored, equals about 1 American or short ton of ice (2,000 lbs.), or 62 cub. ft., 1 English ton. In small ice houses in which the ice is closely packed, a short ton of ice can be got into from 40 to 45 cub. ft.

When withdrawing ice from a store breaking-out bars for bottom and side breaking are required, and if properly skilled assistance is not available a considerable amount of the ice will in all probability be broken up and wasted.

The wastage of ice in an ice store not artificially cooled, from January to July is, in the United States, at the rate of about .1 lb. of ice per twenty-four hours for each square foot of wall surface, or say from 5 to 10 per cent. of the ice stored during the six months.

The amount of heat that will pass through 1 sq. ft. of ice 1 in. in thickness is put at 10 British thermal units per hour for each degree Fahrenheit difference between the respective temperatures on each side of the sheet of ice.

In handling and selling ice, the waggons should be clean and sanitary, the men in charge should avoid walking about in them with dirty boots, and blocks of ice should not be deposited and slid about on filthy pavements. These matters are attended to in the United States, but here they are totally neglected.

In the United States the selling and delivery of ice is generally done by the coupon system, which is thus described by Prof. Siebel: "It is a system of keeping an accurate account with each customer of the delivery of and the payment for ice by means of a small book containing

coupons, which in the aggregate equal 500 or 1,000 or more pounds of ice taken by the customer every time ice is delivered. These books are used in the delivery of ice in like manner as mileage books or tickets are used on the railroad. A certain number of coupons are printed on each page, each coupon being separated from the others by perforation, so that they are easily detached and taken up by the driver when ice is delivered. Such books are each supplied with a receipt or due bill, so that if the customer purchases his ice on credit, all that is necessary for the dealer to do is to have the customer sign the receipt or due bill and hand him the book containing coupons equal in the aggregate to the number of pounds of ice set forth in the receipt or due bill. The dealer then has the receipt or due bill, and the customer has the book of coupons. The only entry which the dealer has to enter against such purchaser in his books is to charge him with coupon book number, as per number on book, to the amount of 500, 1,000, or more pounds of ice, as the value of the book so delivered may be. The driver then takes up the coupons as he delivers the ice from day to day."

ICE-CRUSHING OR BREAKING MACHINERY.

A class of machine required in most modern ice factories is that for ice-crushing or breaking. There are numerous uses for this type of machine, but probably the most important is the crushing of ice for use on board fishing smacks and vessels, where it would be comparatively useless in large solid blocks, and must be crushed or broken up into small pieces before it can be satisfactorily employed for the purpose of packing the fish. This latter desideratum likewise applies to the transport of fish by rail, and to the requirements of fishmongers, hotels, restaurants, &c. Fig. 393 shows a belt-driven machine having a crushing capacity of 15 tons per hour, built by Messrs David Bridge & Co., Castleton, Manchester, a firm that have made a speciality of this class of machinery. The machine consists essentially of a suitable hopper to receive the blocks or pieces of ice, and a pair of crushing or breaking rollers provided with steel spikes arranged in such a manner that the ice will not be allowed to slip or slide, and the breaking operation will consequently commence without loss of time. The breaking or crushing rollers are suitably geared, and the bearings are independent, gunmetal bushed, and provided with effective lubricating arrangements. An excellent feature in the design of the machine is that all the parts are so arranged as to be readily accessible for cleaning and repairs.

Besides the machine shown, the firm also make various other sizes of power-driven crushers from $1\frac{1}{2}$ tons up to 30 tons per hour capacity, as well as small hand-power machinery intended for the use of fish-mongers, and in hotels, restaurants, or anywhere, in fact, where it is

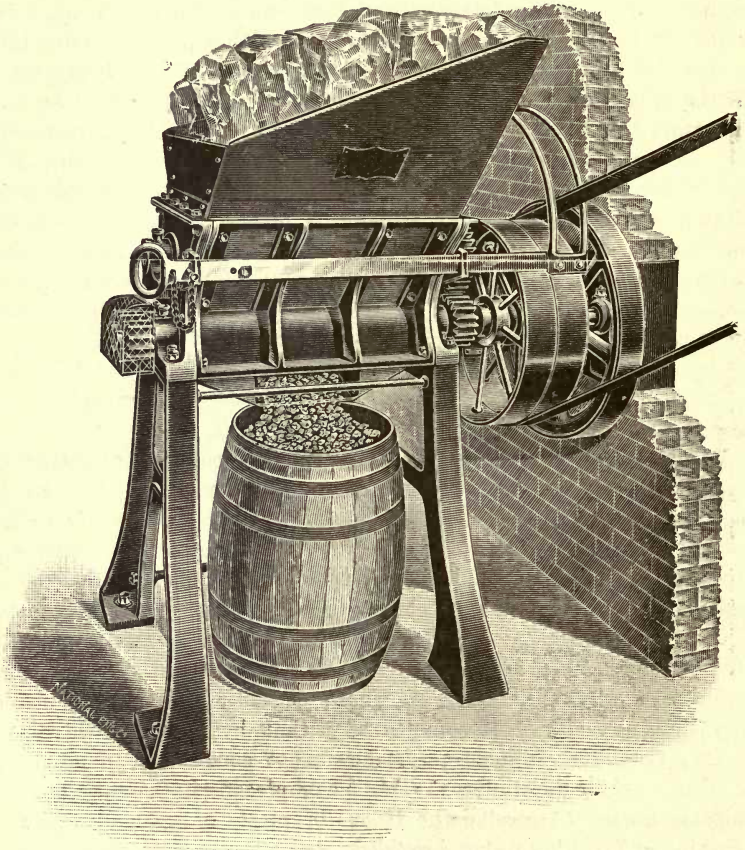

Fig. 393.—15-Ton per Hour Ice-crushing Machine.

required to crush or break ice from the block, but the demand is not large. These latter machines are made in three sizes, viz., of 10, 15, and 25 cwt. capacities. Ice-crushing machines are also made by Mr C. E. Barton, of Grimsby, and others.

CHAPTER XX

THE MANAGEMENT AND TESTING OF REFRIGERATING MACHINERY, ETC.

Management—Ammonia Compression Machines—Oil Separators or Collectors—Accumulations of Deposit in the Condenser—Breaking Joints—Lubricating Qualities of Ammonia—Compressor Piston-Rod Packings—To Charge and Work a Carbonic Acid Machine—Freezing or Choking up of Compression System—Lubrication of Refrigerating Machinery—Leaks in Ammonia Apparatus—Leaks in Carbonic Acid Machines—Effect of a Coating of Ice on Direct-Expansion Pipes—Defrosting Refrigerating Coils—Incrustation on Condenser Coils—Cold-Air Machines—Testing—Interpretation of Compressor Diagrams—Absorption Machines—Amount of Water required in Refrigerating Apparatus—Determination of Moisture in Air—Psychrometers—Hygrometers—Electrical Temperature Tell-Tales and Long-Distance Thermometers—The Thermograph—The Telethermometer or Electrical Thermometer—Lighting Cold Stores.

MANAGEMENT.

AMMONIA COMPRESSION MACHINES.

EVERY particular type of machine working on this principle has, as a rule, certain distinctive or characteristic features, and will, of course, so far at least as these are concerned, require special care and adjustment, and it would consequently be totally impossible to lay down an arbitrary set of rules for working that would be suitable to all; nor is this necessary or required, as full particulars relating to the manipulation of each particular machine are invariably supplied by the makers. The following points, however, are more or less applicable to all machines working on the ammonia compression principle, and should therefore be familiar to those in charge of same.

Before charging an empty machine with anhydrous ammonia, all air must first be carefully expelled. This is effected by working the pumps so as to discharge the air through special valves which are usually provided on the pump dome for that purpose.

The entire system should have been previously to this thoroughly tested by working the compressor, and permitting air to enter at the

suction through the special valves provided for that purpose, and it should be perfectly tight at 300 lbs. air pressure on the square inch, and should be able to hold that pressure without loss. Whilst testing the system under air pressure it should be also carefully blown through and thoroughly cleansed from all dirt, every trace of moisture being likewise removed.

It is totally impossible to eject all air from the plant by means of the compressor, therefore it is advisable to insert the requisite charge of ammonia gradually and not all at once, the best practice being to put in from 60 to 70 per cent. of the full charge at first, and cautiously permit the air still remaining to escape through the purging-cocks with as little loss of gas as possible, subsequently inserting an additional quantity of ammonia once or twice a day, until all the air has been got rid of by displacement, and the complete charge has been introduced.

To charge the machine, the drier or dehydrator of the apparatus for manufacturing or generating anhydrous ammonia, or, where no such apparatus is included in the installation, the drum or iron steel flask of anhydrous ammonia, should be connected, through a suitable pipe to the charging valve; the expansion valve must be then closed, and the valve communicating with the drier or dehydrator, or that in the flask or bottle, opened. The machine should be run at a slow speed when sucking ammonia from the drier, or whilst the flask is being emptied, with the discharge and suction valves full open. In the latter case, when one of the flasks or bottles has been completely emptied it must be removed, the charging valve having been first closed, and another placed in position, until the machine is sufficiently charged to work, when the charging valve should be finally closed, and the main expansion valve opened and regulated. A glass gauge upon the liquid receiver will show when the latter is partially filled, and the pressure gauges, and the gradual cooling of the brine in the refrigerator (in the case of a brine circulation or ice-making apparatus) and the expansion pipe leading to the refrigerator coils becoming covered with frost, indicate when a sufficient amount to start working has been inserted.

It is sometimes advisable to slightly warm the vessels or bottles containing the anhydrous ammonia by means of a gas jet, or in some other convenient manner, whilst transferring their contents to the machine, as otherwise if frost forms on the exterior of the bottles they will not be completely discharged, and loss of ammonia will ensue.

The flasks, bottles, or other receptacles containing the anhydrous

ammonia should be always kept in a tolerably cool and a perfectly safe situation, and they should moreover be moved and handled with the utmost caution and care.

In the event of an accident occurring and any considerable quantity of the ammonia becoming spilt, it is well to remember that it is so extremely soluble in water that 1 part of the latter at a temperature of 60° Fahr. will absorb some 800 parts of the ammonia gas, therefore water should be employed to kill or neutralise it, and any person attempting to penetrate an atmosphere saturated with this gas should not fail to place a cloth well saturated with water over his nose and mouth, or better still, a suitable helmet or respirator.

The machine having been started, and the regulating valve opened, it is essential to note carefully the temperature of the delivery pipe on the compressor, and if it shows a tendency to heat, then the regulating valve must be opened wider; whilst, on the contrary, should it become cold, the valve must be slightly closed, the regulation or adjustment thereof being continued until the normal temperature of the above pipe is the same as that of the cooling water leaving the condenser. When the charge of ammonia in the machine is insufficient, the delivery pipe will become heated, and that even when the regulating valve is wide open.

There are many additional signs of the healthy working of the apparatus other than the fact that it is satisfactorily performing its proper refrigerating duty, which soon becomes easily recognisable to those in charge. For example, every stroke of the piston will be clearly marked by a corresponding vibration of the pointer or indexes of the pressure and vacuum gauges. The frost visible on the exterior of the ammonia pipe leading to and from the refrigerator will be about the same. The liquid ammonia can be distinctly heard passing in a continuous and uninterrupted stream through the regulating valve. The temperature of the condenser will be about 15° higher than that of the cooling water running from the overflow. And, finally, the temperature of the refrigerator will be about 15° lower than the actual temperature of the brine or water being cooled.

Air will find its way into the system through leaky stuffing boxes, improper regulation of the expansion valve, &c. Its presence in any considerable volume is shown by a kind of whistling noise, the liquid ammonia passing through the expansion valve in an intermittent manner, a rise of pressure in the condenser, and also loss of efficiency thereof, and other obvious signs. In this case the air must be got rid of through the purging-cocks in a similar manner to that which remains in the system when first charging the machine.

The presence of any considerable amount of oil or water in the system, which may result from careless distillation, will cause a reduction in efficiency, and will be evidenced by shocks within the compressor cylinder.

The temperature can be regulated either by running the machine at a higher speed or by increasing the back pressure, or by a combination of both. The back pressure can be regulated by means of an expansion valve or valves fitted between the receiver and the refrigerator evaporating coils or pipes in the main liquid pipe.

It is absolutely necessary that an ample supply of oil for lubricating purposes be forced into the stuffing box of the compressor at frequent intervals, otherwise it will be found that the heated ammoniacal gas at high pressure will very rapidly cut through even the very best packing. Pure mineral oil of good body is found to be the best lubricant; animal and vegetable oils should not be used, as on contact with ammonia they will saponify, and much trouble and loss will ensue therefrom.

Another matter requiring special attention is the proper lift of the suction and discharge valves, and these should invariably be provided with suitable means for admitting of the lift being readily adjusted. The lift should not be too high, otherwise the valves will not close with sufficient promptitude, and a loss of efficiency will result, and that more especially in compressors running at high speed.

When superheating of the ammonia gas in the compressor is guarded against by the circulation of cooling water through a jacket surrounding the latter, it is desirable to ascertain the proper amount of water necessary to secure the best results. This will, of course, vary with the condensing pressure; about 12 gals. of water per hour for each ton of refrigerating effect per day of twenty-four hours being usually found to be sufficient for low condensing pressures of, say, from 95 to 110 lbs., whilst, on the other hand, with a high condensing pressure of about 150 lbs. the amount will have to be increased to 50 gals. or more per hour.

The larger the amount of cooling water that is employed in the separator jacket the better; and this water need not be wasted, as it may be conducted through a suitable overflow into the condenser, and utilised together with that delivered specially thereto. The overflow pipe conducting this water to the condenser should preferably dip down for a certain distance into the condenser.

Respecting the quantity and temperature of the cooling water for the condenser, it must be remembered the lower the temperature of the

condensed ammonia the less will be the pressure against which the compressor has to work, and consequently the greater will be the saving in fuel and in wear and tear to the moving parts.

The amount of condensing water required will vary in accordance with the temperature at which it is run from the condenser. For instance, if the condensing water be run into the condenser at a temperature of about 60° Fahr., and leaves at the overflow or waste at a temperature of, say, 90° Fahr., the quantity of water required will be about 1 gal. per minute for each ice capacity of 1 ton per twenty-four hours; whilst if the temperature of the overflow or waste were 75° Fahr., the original temperature at the inlet being the same as before, the amount of water required would be about 2.5 gals. per minute for each ice capacity of 1 ton per twenty-four hours, and a reduction of about 40 lbs. in the condensing pressure would be effected. In large towns and cities, however, where the water from the water companies' mains has to be used, and paid heavily for, it is often doubtful economy to attempt to reduce the temperature of the condensed ammonia below a certain point, say 60° Fahr., during the winter months, and 70° Fahr. during the summer months. It is obvious that when a high price has to be paid for the water employed for cooling and other purposes, every effort possible should be made to utilise it to the fullest extent, and, with this end in view, it is desirable to use the overflow water from the condenser for boiler-feeding purposes, or to employ some means, such as a cooling tower, for saving that which would be otherwise run to waste and be completely lost.

To prevent loss of efficiency from heating of the condensed ammonia, it is advisable that the receiver and piping should be covered with a thick layer of some suitable non-conducting material, which precaution is the more necessary, inasmuch as the piping generally passes through the engine room, and consequently the temperature of the ammonia is not infrequently raised as much as 25° above that at which it left the condenser before it enters the coils or pipes of the refrigerator, which causes a loss of about 2.5 per cent. on the ice-making capacity of the machine. The pipes conveying the ammonia gas from the coils or pipes of the refrigerator to the compressor should be likewise well covered with non-conducting material, so as to prevent, as far as possible, any further accession of heat in the gas during the transit. The desirability of this will be readily seen when it is remembered that the refrigerating capacity of a machine of this type is dependent upon the weight of ammonia circulated, and that the volume of a given weight of the gas increases in proportion to the

elevation of its temperature, and consequently the higher this is raised the smaller will be the weight of the gas circulated or dealt with by the compressor, although the volume may be the same.

OIL SEPARATORS OR COLLECTORS.

In the case of a compressor wherein the cylinder is cooled by a water circulation round its exterior walls, and not by the introduction of cooling liquid to the interior thereof, a certain amount of the oil employed for lubricating purposes will gain access to the interior round the piston rod, and this oil would, unless proper means be taken to prevent it, be carried through the discharge valve along with the ammonia gas, and, after first passing into the condenser, would finally gain access to the evaporating or expansion coils or pipes of the refrigerator, and also stop or clog up the expansion valve, and otherwise reduce the efficiency of the machine.

The method employed for recovering any oil carried over with the ammonia gas in a compressor of the De La Vergne type, employing a sealing, cooling, and lubricating liquid in the cylinder, has been already mentioned when dealing with that machine; with compressors wherein other means are employed for ensuring a complete or a practically complete discharge of the ammonia at each stroke of the piston, suitable oil separators or collectors for the mechanical separation of the oil from the gas, and in some cases rectifiers are used. The oil separator, which should be at least as large as the liquid-ammonia receiver is, as a rule, placed in the main pipe between the compressor and the condenser. Another oil separator or trap is frequently fitted on the expansion or low-pressure side of the refrigerator, usually in close proximity to the inlet to the compressor pump. The object of this latter is to intercept any scale, dirt, &c., from the pipes, and prevent its gaining access to the pump cylinder and injuring the piston and valves. The shells of these separators or traps are usually constructed of wrought iron or steel, and it is essential to have perfectly gas-tight joints.

The separator or oil collector frequently supplied consists merely in a cylindrical vessel into which the ammonia gas is conducted at one extremity and leaves at the other. The inlet and outlet being situated at some inches from the ends or covers, the gas is supposed to be freed from the oil carried over therewith by coming in contact with the sides of the cylinder, and it passes on to the condenser, whilst the oil falls to the bottom of the vessel.

A better form of separator is that wherein baffles or plates, descending vertically to slightly below the centre of the cylindrical vessel, and extending alternately nearly but not quite to the opposite sides of it, are employed. In this arrangement the gas is admitted at one side of the cylinder, and, after taking a zigzag course between the baffles or plates, leaves at the other side. A very considerable increase of contact surface is thus ensured in a separator of this type, a modified form of which is employed in the De La Vergne system, and the separator is rendered considerably more efficient.

The gas being at a temperature of some 200° Fahr. when passing through the separator or interceptor, the oil contained or carried over with it is in a limpid condition, and is, therefore, difficult to eliminate from the gas. To obviate this objection the separator or oil collector is sometimes water-jacketed, by which means the temperature can be maintained low enough to cause the oil to separate easily from the gas and fall to the bottom of the cylinder or vessel. By this arrangement its efficiency is still further increased.

Puplett and Rigg's patent separator or interceptor has been already described in a previous chapter, and centrifugal oil separators have also been used with some success. A type of oil separator recommended by some makers is fitted with an arrangement of wire screens.

A separator of this latter type was patented in 1887 by S. Puplett and J. L. Rigg, which consisted of a cylindrical vessel having a water jacket through which a circulation of cooling water is maintained, and provided centrally with two or more sheets or screens of wire gauze or perforated sheet metal, by which the cylindrical vessel or chamber is divided vertically into two compartments. The gas from the compression pump is discharged into this vessel or chamber against the sheets or screens, and is forced through the interstices or meshes, the surface contact separating the oil, held in mechanical suspension, from the gas. The separator being maintained at a lower temperature than the gas by means of the above-mentioned water-jacket, a rapid condensation of any oil passing over with the gas takes place, and this oil is first deposited on the sheets or screens, from which it falls to the bottom of the separator, from whence it can be drawn off through a discharge-cock fixed therein, without stopping the machine, and without any material loss of gas or admission of air occurring.

To catch any oil that may pass down the return-liquid pipe, an interceptor is attached to the latter in any convenient position, but preferably as near as possible to the refrigerator. This interceptor is

formed of a cylindrical vessel having a diaphragm extending from the cover to within a short distance of the bottom, and another diaphragm extending from the bottom thereof to within a short distance of the cover, thus forming three compartments. The return-liquid pipe passes through the cover nearly, but not quite, to the bottom of the interceptor on one side of the first diaphragm—that is in the outer compartment—and is continued from near the bottom of the interceptor to

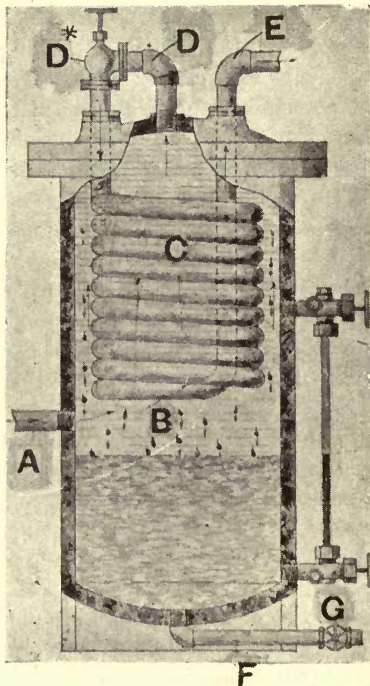

Fig. 394.—Voorhees Oil Separator or Collector. Vertical Central Section.

beyond the second diaphragm, that is to say, out of the third compartment. Any oil that passes down the return-liquid pipe collects in the first compartment of the interceptor, from whence it can be withdrawn through a cock fixed in the first compartment without stopping the machine, or causing an appreciable loss of gas or the admission of air to any injurious extent. This interceptor is preferably jacketed, and is surrounded with, and maintained at a suitable temperature by means of, cold brine, in order to aid in separating the oil from the liquefied gas.

Even the best of the ordinary separators or oil collectors at present in common use are, however, more or less defective in action, and those having under their charge expansion coils or brine coolers are well aware of the fact that considerable quantities of oil gain access to the

expansion coils or the ammonia space of the brine cooler in compression systems. This oil, it is well known, is a great drawback to the successful working of the system, acting as an insulator and preventing the efficient transfer of heat from the ammonia to the pipes and also occupying a considerable part of the space required for the liquid ammonia. The oil is in a finely-divided and partially vaporised condition, for which reason the ordinary separators fail to eliminate it

from the liquid ammonia. The obvious remedy seems to be to so construct the separator that the liquid ammonia will be cooled before passing to the expansion valve and so as to condense the oil vapour and separate same from the liquid ammonia. This action would be ensured in the oil separator shown in Fig. 394, designed by Mr Gardner T. Voorhees, S.B., M.A.S.M.E., which was described in "Ice and Refrigeration." The liquid ammonia from the condenser, after passing through the gas trap, then passes by pipe A into the space B of the separator. Here the velocity of the liquid ammonia is reduced by the large flow area of the separator. The ammonia flows slowly over the outer surface of the coil C. This coil is as cold as the cold liquid ammonia after it has passed the expansion valve. This cold coil cools the whole body of the liquid ammonia in the separator, and the oil separates out in small globules as shown, and settles to the bottom of the separator.

The liquid ammonia, now free from oil, passes out by the pipe D to the expansion valve D*, and expands through the coil C, passing out through the pipe E to the expansion coils, or to the ammonia space in the brine cooler. The oil can be seen in the glass of the automatic gauge-cocks, and can be drawn off from time to time through the pipe F and the valve G. The separator can be insulated or not, as desired. If insulated the only loss of refrigeration would be a neglectable small one through the insulation. If uninsulated, it would be relatively small, and less than is often found in uninsulated liquid headers and expansion valves.

Fig. 395 shows a modified arrangement of the catch-alls or interceptors employed on the Yaryan patent evaporators, which could also be used for the elimination of the oil. As will be seen from the illustration it consists in a cylinder A, which is water-jacketed as shown at A¹, and divided into two compartments by a tube-plate or partition B, from which project tubes C, C, which extend round the gas outlet pipe D, and extend nearly but not quite to the end of the cylinder, the outlet pipe extending into the cylinder for a distance equal to about half the length of the tubes. E is the inlet pipe through which the ammonia gas and the particles of oil carried over therewith are delivered into the first chamber of the separator or oil collector, F is a wire gauze or perforated screen or diaphragm, and F¹, F¹ are baffle or check plates which extend alternately to within close proximity to the opposite sides of the cylinder. A clearance is likewise provided at the bottom of each of the baffle or check plates F, and of the partition or tube-plate B, to allow of the free passage

of the oil from the first compartment or chamber to a well formed in the bottom of the separator cylinder A; G is a pipe leading from this well, through which the oil can be drawn off when required; H, H¹ are respectively the inlet and outlet pipes for the cooling water to the water jacket.

In operation the gas and oil enter the first chamber or compartment of the separator and pass to the tubes c through the wire gauze diaphragm F, and taking a zigzag course from side to side of the separator past the baffle or check plates F¹. A large proportion of the oily particles strike against the diaphragm, and the check, division, or baffle-plates F¹, and become separated from the gas, finally falling to the bottom of the compartment and passing to the well A². The

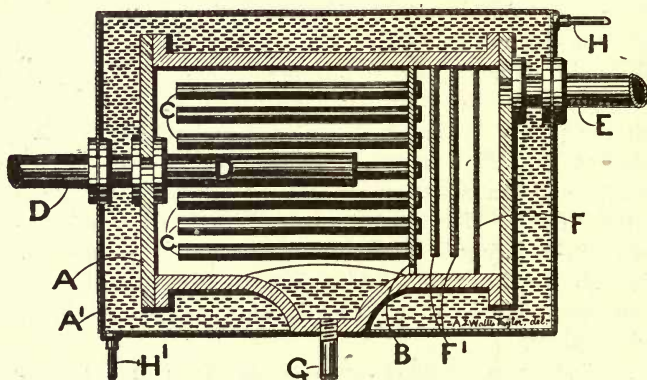

Fig. 395.—Yaryan Form of Oil Separator, Collector, or Interceptor.
Vertical Central Section.

partially cleared gas then passes through the interior of the open-ended tubes c into the second chamber or compartment, and returns along the space on the outside thereof to the outlet pipe D, the remainder of the oily particles becoming deposited on the interior and exterior surfaces of the tubes c, and on the walls of the compartment, from which they likewise fall, and are collected in the well in the bottom of the latter. The very extended surfaces with which the gas thus comes in contact during its passage through the separator or collector will ensure the complete deposition of the oil held in suspension by the gas, and the latter will finally pass out from the separator or oil collector at the outlet pipe D completely, or practically completely, freed therefrom.

The separator or oil collector is sometimes so connected with the compressor that the oil can be used over again; this, however, is objectionable in the case of a double-action compressor, as the connection is liable to become choked with pieces of packing that find their way into the separator. When a rectifier is used, the separator is in some instances connected therewith through a rotary cock, operated from the main shaft by means of a band, which cock is kept constantly working discharging a small quantity of oil at each revolution into the rectifier, so long as any remains in the separator. The failure of oil in the separator is indicated by the connecting pipe between the latter and the separator becoming covered with frost, when the cock must be immediately thrown out of gear and the oil allowed to accumulate in the separator before re-starting it. When the separator is connected directly with the rectifier the cock in the connecting pipe should be opened periodically, say about every twelve hours. The oil may be discharged from the rectifier at about similar intervals, and the amount of oil that is found to be entering the compressor cylinder is an index to the state of the packing in the stuffing box, a large quantity being a certain sign that it requires renewal or seeing to. It is most important that the separator or oil collector be cleaned out at pretty frequent and regular intervals.

The liquid ammonia receiver is invariably located below the condenser, a supply pipe being led from it to the evaporator or refrigerator governed by the expansion cock or valve.

Fig. 396 illustrates a type of ammonia receiver and oil trap made by the Triumph Ice Machine Co. The pipe shown passing through the vessel is the suction pipe to the compressor pump cylinder, and when this pipe becomes coated with frost, it materially assists in cooling the liquid ammonia, and thereby greatly increasing the efficiency of the plant. At the top of the receptacle is a wire gauze strainer, shown in plan on the left-hand side of the drawing, which prevents foreign bodies and impurities from gaining access to the system. (See also pages 76, 509, and 510.)

ACCUMULATIONS OF DEPOSIT IN THE CONDENSER.

It not infrequently happens that deposit accumulates on the exterior surface of the condenser coils from sediment in the water, and on the interior surface thereof from oil and foreign bodies. The smaller ammonia pipes may sometimes become filled with obstructions to the extent of completely blocking them up. These bodies may

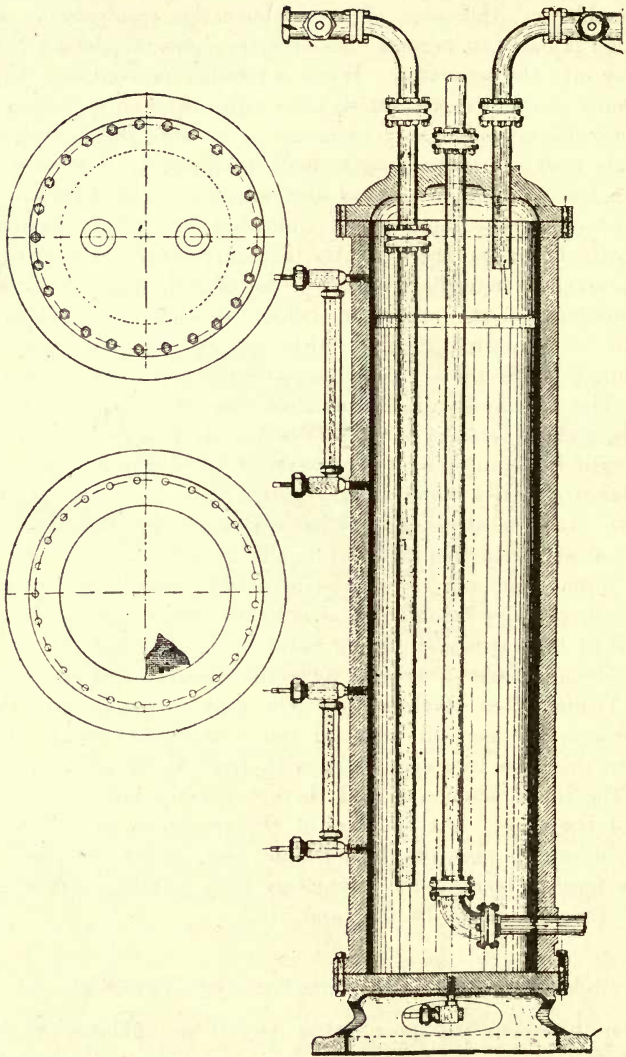

Fig. 396.—Triumph Ice Machine Co. Ammonia Receiver and Oil Trap. Vertical Central Section and Detail Views.

consist of lumps of solder or other matter accidentally left in the tubes when making the joints, or of pieces of packing from the stuffing box carried over with the gas. The deposit or furring of the condenser coils or pipes is objectionable inasmuch as it acts as a non-conducting covering, and prevents them from freely transferring the heat to the cooling water, and the choking of other conduits is likewise followed by corresponding loss of efficiency, for example, that of one of those leading to one of the refrigerator coils or sets of pipes will result in the latter not acting at all, or only very slightly. Complete choking up or obstruction of one of these latter conduits is evidenced by that particular pipe, and also the corresponding return pipe, not becoming covered with frost at all, or only so to a very small extent; and a slightly less degree of frost upon any of these pipes indicates partial choking or obstruction, and a consequent very feeble action of the coil or set of pipes.

The coils or pipes in the condenser should be frequently cleaned on the exterior with a suitable brush, and, whenever practicable, removed at fixed periods and carefully scaled. This is best and most easily effected by heating the tubes, care being taken, however, not to carry such heating to an injurious extent. The interior surfaces of the tubes can be cleansed by blowing steam through them at a considerable pressure. To clear small obstructions from a conduit leading to one of the refrigerator coils or sets of pipes, it is usually sufficient to turn the entire stream of ammonia into it. Should, however, the obstruction prove obstinate, and it be found impossible to shift it in this manner, an early opportunity must be taken to clear it by blowing steam through it. Any considerable choking of the conduits leading to the refrigerator coils is followed by a very marked decrease of efficiency in the latter.

BREAKING JOINTS.

Whenever a joint has to be broken, and any portion of the machine opened for any purpose whatever, it is absolutely essential that the whole of the ammonia contained in that part should be pumped or transferred to another part, or if this cannot be done it should be discharged, preferably into water, which can readily be effected by means of a short strong india-rubber tube. On account of the already-mentioned great solubility of ammonia in water, it will become readily absorbed, if the vessel into which it is discharged be kept sufficiently replenished with cool water. It is of the utmost importance that the

rule of carefully removing all ammonia pressure before breaking a joint be strictly adhered to.

In warm weather, or in hot climates, the joints will require constant attention, and periodical inspection, and tightening up of the bolts; and at all times, even in the winter in this climate, they are liable to develop leaks through the working of the machinery.

LUBRICATING QUALITIES, &c., OF AMMONIA.

Ammonia being a good solvent, and having no effect upon iron or steel, the parts will become clean and free from deposit, after working for a short period, and the cylinder and piston will be found highly polished. Ammonia also possesses some slight lubricating qualities, and, therefore, after starting, no other lubricant need be introduced into the compressor cylinder. The cylinder covers, as also the valve box covers, should be occasionally removed and a thorough inspection made of the piston, cylinder, and valves. The latter are exceedingly apt to become cut or marked by fragments of scale, and require grinding in periodically.

COMPRESSOR PISTON ROD PACKINGS.

A properly packed piston rod will remain in good order for at least six months, provided the rod be in first-rate condition and perfectly true; under contrary conditions, however, trouble will be experienced in a fortnight or less. The usual precautions to be observed in order to properly pack a steam engine or other stuffing box, which are well known, or should be so, to those in charge of ammonia plants, are equally applicable in the case of the compressor, but the herein-before-mentioned extensively searching nature of ammonia gas demands the exertion of extra care. These observations apply more especially in the case of a double-acting compressor.

For single-acting compressors metallic packing will be found the best, that of Victor Duterne, the patent for which expired many years ago, being an excellent one for the purpose.

A single-acting compressor stuffing box, being only subjected to the suction pressure, that is to say, to one of about 28 lbs. per square inch, or even less, the maintenance of a tight joint is a matter of comparative facility. With a double-acting compressor, however, the case is different, as the pressure will vary from 125 lbs. at the lowest to sometimes as much as 180 lbs. at the highest, and with such a searching gas

as ammonia the stuffing box is a part likely to give the engineer in charge at least as much concern as any other portion of the machine. Should, however, the piston rod be in first-rate condition and perfectly true, a properly-packed stuffing box will, as already mentioned, enable a gas-tight joint to be maintained for six months or more; with the opposite state of things leakage will probably occur in a fortnight or less, and in practice the rod will seldom be found to be in the first-named state of high perfection, consequently the joint may be expected to remain tight for any period of time between the two above-mentioned.

The stuffing box should be of considerable depth, say a foot, a clearance of from $\frac{1}{2}$ to $\frac{3}{4}$ in. being left between the piston rod and its inner wall. Fig. 397 is a diagram from a sketch given in an American journal showing one form of stuffing box and method of

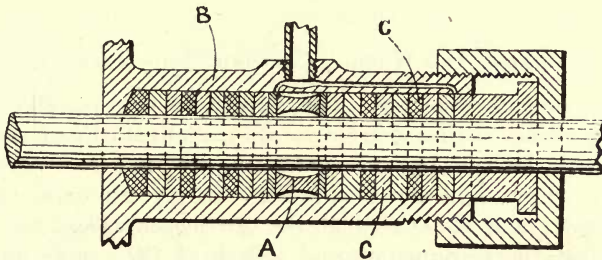

Fig. 397.—Stuffing Box and Packing for Ammonia Machine.
Longitudinal Section.

packing, from which it will be seen that it is packed in two sections, a steel lantern A, some inches long, being inserted centrally in the stuffing box B, with packing C on each side of it.

Double-acting compressor stuffing boxes are best packed with combinations of packings, metallic packings (which are found very suitable for the stuffing boxes of single-acting compressors) not giving good results with the former. Many of the special and patented packings will be found suitable. Plaited cotton packing, cut into suitable lengths, and inserted in the form of rings, may be employed, it being desirable, however, in this case to finish off with a couple or more rubber insertion rings.

Packings consisting of india-rubber and duck, and indeed most packings of good quality containing india-rubber, are suitable when the piston rod is in good order, and the larger the proportion of rubber the

better, as the ammonia has no injurious action upon the latter, only making it swell and become spongy, and thereby enabling a gas-tight joint to be maintained with but a trifling amount of friction.

The packing should be driven home tightly, piece by piece, with a packing stick made of hard wood, and a mallet, the gland being finally screwed on by hand only, so as to allow for the expansion of the packing. This latter precaution is absolutely necessary in order to ensure the maximum life of the latter. When tightening up the gland care must be taken to do so equally all round, and not to screw up the nut on one bolt more than on any of the others.

Several of the patented systems for preventing the occurrence of leakage of gas taking place past the stuffing box have been described in previous chapters, but the present purpose is only to endeavour to show how good a job can be made with ordinary stuffing boxes and packings.

TO CHARGE AND WORK A CARBONIC ACID MACHINE.

The following directions, whilst applying more or less to all carbonic acid refrigerating machines, refer more especially to those made by Messrs J. & E. Hall, Ltd.

Before charging, fill the compressor with glycerine and run the machine for an hour or two with all the valves open wide.

To charge the machine, suspend a flask of CO_2 , valve upwards, from a spring balance and connect by a copper wire to the evaporator. See that connecting joints are tight. The steel flasks contain about 40 lbs. of CO_2 , and the number required will, of course, depend upon the size of the machine.

Open the valve on the flask and on evaporator. The difference in weight between the empty and full flask will denote the weight of CO_2 that has passed into the machine.

After the flasks are half empty, warm them with hot water. When empty close the valve whilst the flask is still warm. Should any CO_2 remain, it will be cold, and at the lower extremity.

On first charging a new machine, blow the air out of the system by breaking the joint between the regulator and the pipe leading to it, the regulator being closed and all other valves open, and blow 2 or 3 lbs. of CO_2 through.

When charging, carefully examine all joints as the pressure rises, using soap and water for the purpose.

The CO_2 gauges on condenser and evaporator indicate on the

outer circle the pressure in atmospheres, and on the inner circle the corresponding temperatures of CO_2 .

When fully charged, start the machine with all the valves open and adjust the regulator (*i.e.*, the inlet valve of the evaporator) so that the condenser gauge will indicate on the inner circle 5° to 10° above the temperature of the cooling water at the inlet to the condenser, and the evaporator gauge 10° to 15° below the temperature of the brine or water to be cooled.

Under normal working conditions the compressor should be cold or partly covered with snow, and the delivery pipe from it should be rather warmer than the hand can comfortably bear. If the delivery pipe is not hot enough, slightly close the regulator, when the temperature will quickly rise. If the compressor becomes warm, it points to the regulator being insufficiently open.

Should it be impossible to secure the conditions above-mentioned, the system is short of gas. To further test this, close the regulator, and if the evaporator gauge falls rapidly and continuously, the system is short of gas. If properly charged, the gauge should remain almost stationary for several revolutions of the machine. Besides, if sufficient gas be present in the system, the condenser gauge could hardly rise at all, even after working two minutes.

When short of gas, or in doubt, insert more, extra gas in the system, up to a quarter charge, will do no harm. It will be indicated by the condenser gauge showing 20 or more degrees above the inlet water temperature. If the machine be short of gas the refrigerating work done will be but a fraction of its proper duty.

The temperature of the brine to be maintained depends, of course, upon the refrigeration that is to be performed.

The clearance spaces at the ends of the compressor being small, they must be maintained equal at both ends.

The hydraulic leathers forming the piston packing will require examination and removal occasionally, and it is particularly necessary that the nut securing these leathers should be well screwed up and locked. After putting in new leathers it is advisable, two days after starting, to tighten up the nut again.

The suction and delivery valves should be examined periodically. When they require re-grinding, spare ones may be put in.

In machines with the valve seatings making double joints, see that both copper rings are equally crushed by the valve casing. Leakage at the outer joint will indicate itself outside, but at the inner joint will not be perceptible except in reducing the work done by the machine.

To test the work of the compressor, close the regulator, when the evaporator gauge should be pumped down from say 25 atmospheres to 5 atmospheres in about 200 revolutions. If slower, either the valves or the pistons are faulty.

The gland is packed with two hydraulic batters, between which a pressure of glycerine is maintained by means of the special lubricator provided. The gland should not be screwed up too hard. The lubricator will require pumping up after some hours' work, and when the piston has moved 4 in. This, however, should not occur under three hours if the gland batters and compressor rod are in good order. The lubricator valve should be open a full turn. The glycerine which leaks from the gland should be caught, and after filtering, used again. Great care should be taken to keep the compressor rod free from scratches or marks, which would rapidly destroy the gland leathers.

If short of leathers, the gland may be temporarily packed with ordinary tallow packing, thus: first put in two or three turns of packing, then the spiral ring, and then fill up with packing, care being taken that the ring comes opposite the glycerine outlet when the gland is screwed up.

Any glycerine passing into the compressor will be caught in the separator, and must be drawn off twice daily by slacking the nut at the bottom, and after filtering, used over again.

All glycerine used should be free from water, acid, and dirt.

On the suction side of the compressor is a strainer, and, with a new machine, this should be taken out and cleaned after the first and second day, and then occasionally.

When stopping, it is not necessary to close any valves. The gauges will then equalise, standing at the pressure of the evaporator. Before starting, care should be taken to see that all the valves are open, a safety valve, however, is provided to relieve the pressure should this be neglected.

The speed will vary in accordance with the size of the machine.

It is particularly necessary that all pipes, joints, and glands of spindle-valves should be carefully examined and kept tight. For the first few days especially they should be examined daily, and all bolts and gland-nuts screwed hard up. The most minute leak should be instantly stopped.

To examine the compressor, close the suction and delivery, screw down valves, and slack off a joint to let the gas escape. Make sure all pressure is gone before opening up.

When the machine is stopped for a week or more, the piston rod should be withdrawn and oiled, or painted with white lead and tallow.

FREEZING OR CHOKING UP OF COMPRESSION SYSTEM.

In working a compression machine considerable trouble is frequently experienced owing to freezing or choking up. This is caused by small particles of moisture entering with the gas from the compressor, or from the escape of glycerine or oil through the separator, which gradually accumulates in the system, and finally solidifies at the bottom of the evaporator or refrigerator coil, or at the expansion or regulator valve or cock. The latter place is the least objectionable, and as a general rule it can be cleared away by quickly throwing the valve open to its fullest extent. To clear the evaporator or refrigerator coil, a cock should be fitted to the evaporator or refrigerator casing or shell as low down as possible, and to this should be connected a steam pipe or hose from any available source of supply, such as a drain-cock on the steam pipe to the engine. The steam should be turned on slowly, and the temperature of the brine in the evaporator or refrigerator raised to about 70° Fahr., the overflow cock from the evaporator to the brine tank being opened. The effect of this will be to liquefy the oil on the interior of the coil, and it will then run down to the bottom of the latter where the expansion valve should be full opened, so as to communicate with the condenser. If the compressor be then slowly started in the ordinary manner, in about half an hour the oil will float to the top of the liquid and may be drawn off at the separator.

In drawing off or clearing out the separator the drain valve should be prevented from getting too cold, as if it does so the gas will come away in semi-solidified form, and there will be considerable wastage. The clearing out will be necessary about every three or four weeks, and lasts between one and two hours, the rise of efficiency in the machine being very perceptible.

In charging a system, it is always desirable to pass the gas from the charging cylinder through a gas drier, so as to thoroughly cleanse and extract all moisture from it. This drier consists of a vessel fitted with a suitable inlet and outlet valve, and a drain or purging cock, and charged with alternate layers of chloride of calcium and cotton wool.

This apparatus can be also used for the cleansing or purification of the gas already in the system, by connecting the outlet valve on the condenser with the inlet valve on the drier, closing the expansion and condenser outlet valves, and disconnecting the pipe between them. Then opening the outlet from the condenser, inlet to the drier, outlet,

and charging valve on the top of the evaporator or refrigerator, and by working the compressor very slowly, any impurities in the gas will be taken up by the calcium and cotton-wool in the drier.

LUBRICATION OF REFRIGERATING MACHINERY.

This important point, which has been already touched upon in previous portions of this work, is apt to be as much neglected by users of refrigerating machinery as it is by users of other types of machinery. It will be well for these gentlemen to at once dismiss from their minds the idea that low-priced inferior quality oils are really the cheapest, and understand that on the contrary not only are high grade oils necessary to ensure the highest efficiency of the machinery, but that they are also the least expensive in the long run.

In refrigerating machinery the use of three different kinds of oil is demanded: steam cylinder oil, oil for general use, and compressor pump oil.

Oil for the steam cylinder: Good cylinder oil is entirely free from grit, does not gum up the valves and cylinder, and does not evaporate rapidly on exposure to the heat of the steam. The quality of a cylinder oil is demonstrated on removal of the cylinder head. If the oil is of good quality the wearing surfaces should appear well coated with lubricant, which will not show a gummy deposit, or blacken on the application of clean waste.

Oil for general use on all the bearings and wearing surfaces of the machine proper: This may be any oil that will not gum, is not too limpid, possesses a good body, is free from grit and acids, is of good wearing quality, and flows freely from the oil cups at a fine adjustment without a tendency to clog. For the larger bearings it is well to use a heavier grade of oil.

Oil for use in compressor pumps: When it is necessary to use oil in these it should be what is known as zero oil, or cold test oil, that is to say, that it should be capable of withstanding a very low temperature, without freezing, and it should be the best quality. American makers recommend the use of the best paraffin oil and clear West Virginia crude oil.

Mr F. E. Matthews, in dealing with this subject in *Power and the Engineer*, New York, says, that in order that the oils used in the system shall not stiffen prohibitively at the low temperatures encountered, and not be saponified by the ammonia, only very light mineral oils can be employed. Such oils range from 22° to 30° Bé., corre-

sponding to a specific gravity of from 0.924 to 0.88. These oils should have a cold test of about zero Fahrenheit, to obtain which they will have a flash point of between 310° and 400° Fahr. This low flash point implies that a considerable amount of vapour will be given off at a much lower temperature. Since discharge temperatures of compression machines often approach these temperatures, it is obvious that a considerable amount of oil will pass to the condenser, not as a liquid but as a vapour. Under such conditions, since there is no material cooling effect in the oil separator, only liquid oil would be precipitated at that point.

LEAKS IN AMMONIA APPARATUS.

Leaks are readily detected by the smell of the escaping ammonia gas when the machine is being filled; at a later stage, when working, their detection is not so easy. During the operation of the machine when the liquor or brine in the tanks commences to smell of ammonia it indicates a considerable leakage. It is recommended to test the liquor or brine periodically with Nessler's solution or otherwise.

Nessler's reagent, which is the best to use for the discovery of traces of ammonia in water or brine, consists of 17 grms. of mercuric chloride dissolved in about 300 c.c. of distilled water, to which is added 35 grms. potassium iodide dissolved in 100 c.c. of water, and constantly stirred until a slight permanent red precipitate is produced. To the solution thus formed is added 120 grms. of potassium hydrate dissolved in about 200 c.c. of water, allowed to cool before mixing; the amount is then made up to 1 litre, and mercuric chloride added until a permanent precipitate again forms. After standing for a sufficient time, the clear solution can be placed in glass-stoppered blue bottles and kept in a dark place.

If a few drops of this reagent be added to a sample of the suspected brine or water in a test-tube, or other small vessel, and the slightest trace of ammonia is present, a yellow coloration of the liquid will take place; a large quantity of ammonia will produce a dark brown.

When the leaks are comparatively insignificant they can be closed in the usual way, by solder, using as a flux muriatic or hydrochloric acid killed with zinc. In some instances electric welding may be resorted to with advantage, or the leak may be closed by means of a composition of litharge and glycerine mixed into a stiff paste, bound with sheet rubber, and covered with sheet iron clamped firmly in position. When, however, the leak is at all serious it is usually the better plan to at once put in a new coil, or a new length of pipe.

LEAKS IN CARBONIC ACID MACHINES.

To detect these, smear the joints with a solution of soap and water, and any leakage of gas will be evidenced by the formation of bubbles. Carbon dioxide or carbonic acid being a completely inodorous gas, precautions are required to prevent the occurrence of leakage. If the joints, however, are properly made to start with, they are found in practice, when once tight, to remain so for years.

EFFECT OF A COATING OF ICE ON DIRECT EXPANSION PIPES. DEFROSTING REFRIGERATING COILS. INCRUSTATION ON CONDENSER COILS.

The effect of a coating of ice on direct expansion pipes, according to an authority (Mr F. E. Matthews) writing in *Power and the Engineer*, New York, may be shown as follows:—Assuming a heat transfer of 10 B.T.U. in round numbers per hour per square foot per degree of difference in temperature inside and out, for a flat metallic refrigerating surface, and an equal amount of sheet ice 1 in. thick, it follows that the heat transmission through 1 sq. ft. of direct expansion cooling surface insulated with a layer of ice 1 in. thick will be only one-half that of the uncoated surface. As a matter of fact, it would seem from the context that the value of 10 B.T.U. given as the heat conductivity of ice applied to plate-ice conditions under which the wetted surface of the submerged ice will transmit materially more heat than a dry surface in contact with air. This would indicate that the decrease in heat-transmitting capacity of direct expansion surfaces in air due to a coating of ice is even more than 50 per cent. This condition will be partially offset by the fact that on account of the increasing diameter the layer of ice in the case of cylindrical surfaces such as pipes (which, together with the fact that such coatings usually present an irregular surface, further increase the heat-absorbing area) may increase the heat transmission sufficiently to make up for the lesser heat transfer between the air and dry ice, and make 50 per cent. at least a reasonable estimate of the loss in heat-absorbing capacity due to 1 in. of ice.

Under average commercial conditions of intermittent frosting 1 sq. ft. of direct expansion surface in air is usually credited with a heat transmission of only from 2 to 4 B.T.U. per hour per degree difference in temperature.

Brine pipes may be readily defrosted by the circulation of hot brine. This may be accomplished through the main feed and return

headers where the operation does not have to be performed very frequently, or, as in abattoirs, where the excessive amounts of moisture from the hot meats to be chilled make the accumulation of frost very rapid, or by a separate set of defrosting headers.

In the case of direct expansion coils, the defrosting method probably most satisfactory where the cold-storage temperatures are above 32° Fahr. is to instal sufficient coil surface to allow a part of the coils to be shut off at any time, so that the frost will melt without artificial heat, and at the same time produce a certain amount of useful refrigeration. If it is necessary to force the defrosting process by the use of outside heat, a hot gas line from the condenser may be connected to the liquid line connections to the separate coils just inside the expansion valves. The hot gas, after melting the ice as it passes through the coils, returns to the compressor together with the return gas from the remaining coils.

Where the temperatures carried in the cold-storage compartments are below 32° Fahr., and in which the defrosting cannot be effected without the use of artificial heat, often very objectionable, two methods are available, viz., that of forcibly removing the ice with scrapers, and that of suspending over the pipes trays of calcium chloride. This substance is an exceedingly deliquescent salt, which in absorbing moisture from the air forms a saturated calcium brine which freezes at a very low temperature. In trickling down over the coils, the brine melts the ice, forming a more dilute brine, which is then conducted away to the sewer, or, if the quantities involved warrant the expenditure of labour, may be evaporated and the calcium chloride recovered.

While the comparatively high working temperature of condenser coils, together with the usually ample provisions for draining each separate coil, prevents the accumulation of such large quantities of oil as are often lodged in expansion coils, condenser coils are exposed to another source of loss of efficiency from without, where the available cooling water is abnormally hard or carries a large amount of suspended matter. Ammonia condensers, and especially steam condensers, soon become coated with a deposit of scale or mud, which, if not properly removed, becomes a more or less effective insulator according to the composition of the deposit. The heat conductivity of metallic surfaces is not the same per degree difference in temperature at medium and low as it is for high temperatures, and it does not therefore follow that the resistance offered by the scale accumulating on the outside of atmospheric and submerged ammonia and steam

condensers is the same as that of scale on the inside of a boiler. However, some slight idea of the extent of the loss may be gained from the fact that in steam boiler practice, the insulating effect of scale results in thermal loss corresponding to 2 per cent. of the fuel for each $\frac{1}{84}$ in. in thickness of scale. Condenser surfaces like those of steam boilers, expansion coils or any other heat-transmitting surfaces, should be kept as free as possible from deposits of foreign matter.

COLD-AIR MACHINES.

The proper management of cold-air machines is far simpler than that of those working on other principles, the exact treatment of each particular machine, however, varying of course somewhat with the make. In all machines, however, the parts most liable to give trouble are the valves, and these, as also the pistons and slide valves, should be periodically tested, and any defect promptly remedied.

TESTING.

The object of testing a refrigerating plant is in order to ascertain what it is capable of performing under comparable normal conditions, and as regards the amount of refrigeration produced in relation to the expenditure of work, and the coal consumption.

To determine the efficiency of an installation on the compression system, the following fittings are required, viz., an indicator, so that diagrams can be taken from the compressor; stroke counters, to enable the number of strokes made by the steam engine and brine pumps to be ascertained; and mercury wells, to admit of the temperature being obtained at various points throughout the system.

In making a test it is desirable that it should last at the very least for fully twelve hours, and it is better to carry it on for twenty-four hours. The number of readings which it is desirable should be taken from the various instruments will vary in accordance with whether or not the work is steady or otherwise, and the person carrying out the test will have, of course, to use his own judgment on this head. Where artificial ice is made, for example, twice an hour will be sufficient, whilst on the other hand, four or more readings per hour should be taken in cases where the variation in the temperature of the materials to be cooled is wide. Indicator diagrams should be taken from both

the steam engine cylinder and the compressor cylinder every two hours.

A mercury well, for a horizontal pipe, when the latter is of sufficient dimensions, is shown in Fig. 398. It consists in a short piece of tubing closed at its lower end, and fitted into the pipe by means of a suitable bushing. It is filled about three parts full of mercury, and

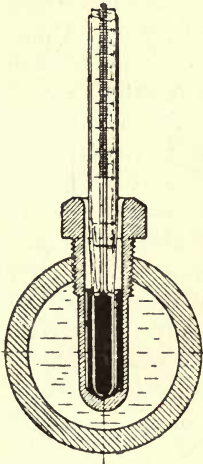
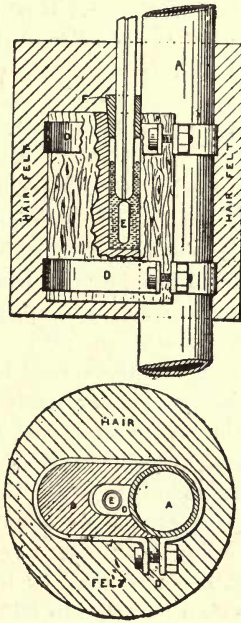

Fig. 398. — Mercury Well for Horizontal Pipe. Vertical Section.



Figs. 399 and 400.—Mercury Well for Vertical Pipe. Vertical and Horizontal Sections.

the thermometer, which should have an elongated cylindrical bulb, is held in position therein by means of a perforated cork. For vertical pipes, or pipes of very small dimensions, where this arrangement would be impracticable, the well is recommended by Mr Redwood* to be formed (as shown in vertical and horizontal section in Figs. 399 and 400) by means of a wooden or other block, one side of which is shaped to the outline of the pipe to which it is to be applied, and has

* "Theoretical and Practical Ammonia Refrigeration."

a suitable recess formed in it. This block is firmly secured against the pipe by metal straps in such a manner that a portion of the wall of the well will be formed by the pipe, the latter being scraped perfectly clean at that part. The joint between the block and the pipe must be made perfectly tight, which can easily be effected by means of a little white lead paint, as there is no pressure, and the whole should be surrounded by a thick layer of non-conducting composition, through which the stem of the thermometer is permitted to project.

The points in the system where it is desirable to locate the mercury wells are:—The suction pipe just at its connection with the compressor; the discharge pipe, as close as possible to its connection with the compressor; the ammonia discharge pipe from the condenser, as near the latter as practicable. Where a brine circulation is employed:—The pipe or manifold supplying the various coils or sets of pipes in the refrigerator; the discharge pipe of the refrigerator; the brine discharge pipe, at the point where it connects to the refrigerator; and the brine return pipe in proximity to where it connects with the refrigerator.

An excess condensing pressure is invariably found in ammonia compression machines. This excess of the actual working condensing pressure over the theoretical is caused by the ammonia gas being imprisoned in the comparatively confined space afforded by the coils or pipes in the refrigerator, and the excess pressure is more marked in a horizontal compressor running at a high speed of, say, 140 revolutions per minute, than it is in vertical ones having only a low speed of from 35 to 60 revolutions per minute; it varies, moreover, in almost every make of compressor. At a low suction pressure of about 15 lbs. it should not be more than 10 lbs., but with a suction pressure of, say, 27 or 28 lbs. it may rise to 50 lbs., or even more.

The condensing pressure affords a means of ascertaining whether or not the apparatus contains the proper full charge of ammonia, or if the losses sustained by leakage are sufficient to render it necessary to insert an additional supply. For this reason it is advisable for the person in charge to keep a record in a proper book, suitably ruled for the purpose, of the temperature of the condensed ammonia when leaving the condenser, and also of the condensing and suction pressures, at regular intervals of, say, three hours. This will enable him to follow the state of the ammonia charge; for example, if the condensing pressure is found to be gradually falling during a three months' period, as compared with the average condensing pressure of the previous three months, whilst at the same time the condensing temperature and the suction pressure remain constant, it will be evident that the charge

of ammonia has become reduced by leakage to a sufficient extent to require replenishing. This reduction in the condensing pressure is caused by the diminution in the charge of ammonia giving larger condenser space, the gas having thus a much more extended worm, coil, or tube space wherein to condense and liquefy, and hence the decrease. As a general rule it may be taken that, whenever the condensing pressure is found to have fallen about 8 lbs., enough ammonia to restore the original condensing pressure should be inserted into the machine.

The following method of testing the capacity of a refrigerating machine is given by Mr Constanz Schmitz in the *Eis und Kalte Industrie* :—

“In testing the effective capacity and the consumption of power of a refrigerating machine, it has been hitherto usual to take the amount of heat removed per hour, and the power consumed in indicated horse-power. This, however, does not afford a satisfactory basis upon which to judge of the relative merits of machines under test. If, for example, the theoretical capacity of any particular refrigerating machine be taken, it will be found in every instance that this capacity will not be reached in practical working.”

A more satisfactory means of comparison is furnished by the results obtained from a large number of caloric production and power consumption tests, which, however, under varying working conditions, and for different sizes of the machines, will not be found to correspond.

To avoid, therefore, possible mistakes, and to facilitate the work, the caloric production and the consumption of power should be reduced to a special unit, and for this purpose the following method is proposed :—

It is expressed in the following manner :—

1. Specific refrigerating efficiency = Q sp.

That number of calories which is indicated per 1 cubic metre hourly volume of stroke of the compressor, in the evaporator.

2. Specific consumption of power = N sp.

That number of horse-power which is indicated in the air compressor for 10,000 calories evaporator production.

Let a compressor have, for instance, the following dimensions :—

| | | | | |
|----------------------------------|---|---|---|-----------------|
| Cylinder diameter | - | - | - | $d = 250$ mm. |
| Piston stroke | - | - | - | $s = 420$ „ |
| Piston rod | - | - | - | $\delta = 55$ „ |
| Number of revolutions per minute | - | - | - | $n = 65$ „ |

Then its hourly volume of stroke is :—

$V = 15.n.s.\pi. (2d^2 - \delta^2) = 156.920$ cub. metres (and since 1,000 cub. dm. = 1 cub. metre, also 1 litre = 1 cub. dm. we have: $V = 156,920$ litres).

Should now the evaporator productions per hour be found by $Q_2 = 63,750$ Cal., the specific refrigerating efficiency of the machine will be :—

$$Q \text{ sp.} = \frac{63,750}{156.92} = 406 \text{ Cal.}$$

Should at the same time during the caloric trial 23.7 H.P. be indicated in the compressor, then the specific consumption of power will amount to :—

$$N \text{ sp.} = \frac{23.7 \times 100,000}{63,750} = 3.72 \text{ H.P.}$$

If then, in addition to this, the evaporator temperature, that is the mean temperature of the volatile cold-producing agent or medium, and the liquefaction temperature in the condenser be given, four figures afford a practical demonstration of the performance of the machine in question.

On the basis of these figures, refrigerating machines may be conveniently compared as regards their productive capacity. The comparison as regards the specific refrigerating capacity $Q \text{ sp.}$ is, of course, only possible directly between machines constructed to operate on the same system, while the comparison as regards the specific amount of power required is rendered directly possible between machines constructed to operate on any system.

INTERPRETATION OF COMPRESSOR DIAGRAMS.

The interpretation of a compressor diagram with respect to the working, valves, defects, &c., of the latter are given as follows by Hans Lorenz, in "Neuere Kuehlmaschinen," Muenchen and Leipzig, 1899 :—

"Assuming all the parts of the machine to be in good order, then the diagram will have the general appearance shown in Fig. 401. The suction line s is only slightly below the suction pressure line v , and the pressure line d is only slightly above the condenser pressure κ . Small projections at the pressure and suction line indicate the work required to open the compressor valves, and the effect of clearance is shown by the curve r , which latter cuts the back pressure line after the piston has commenced to perform its return or back stroke, and consequently

reduces the suction volume to that amount. It can also be seen from this diagram that the vapours are taken in by the compressor, not at the back pressure, but at what may be called the suction pressure, which is somewhat lower. This is the reason that the compression curve *c* does not intersect the back pressure line until after the piston

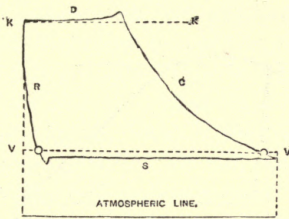

Fig. 401.—Diagram from Compressor in good order.

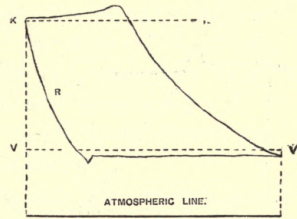

Fig. 402.—Diagram from Compressor indicating an Excessive Amount of Clearance.

has changed its direction of movement. The theoretical volume of the compressor, as indicated by the line *v*, is consequently reduced in practical working for vapours possessing a certain tension.

In Fig. 402 is shown a diagram taken from a compressor having an

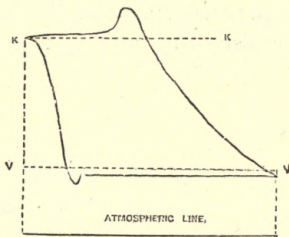

Fig. 403.—Diagram from Compressor indicating Binding of Pressure Valve.

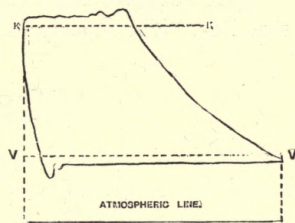

Fig. 404.—Diagram from Compressor indicating too great a Resistance in Pressure and Suction Pipes.

excessive amount of clearance. In this case, it will be seen, the back expansion line *r* passes through a flat course, and thereby reduces the useful volume of the compressor.

Fig. 403 is a diagram which indicates the binding of the pressure valve, which may be due to an inclined position of the guide rod of the

valve. This deficiency also frequently causes a delay in the opening of the pressure valves, a state of things indicated by a too great projection in the pressure line. As soon as the valve is once opened the pressure line pursues its normal course until the piston commences its return stroke, when the defect is again manifested in the back pressure line, as mentioned.

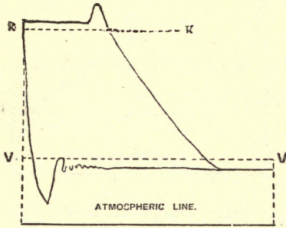

Fig. 405.—Diagram from Compressor indicating Binding of Suction Valve.

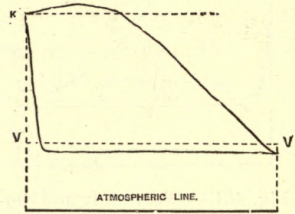

Fig. 406.—Diagram from Compressor indicating Leaking of Compressor Valve.

Fig. 404 shows a diagram indicating too great a resistance in the pressure and suction pipes respectively, when the valves are overweighted. In this case the pressure and suction lines are at a comparatively great distance from the condenser pressure line and the back pressure line. The remedy for this is to replace the valve springs by

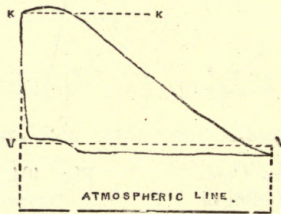

Fig. 407.—Diagram from Compressor indicating Defective Packing of Piston.

weaker ones ; and should there be then no marked effect, then the pipe lines and shutting-off valves should be inspected and, if found necessary, cleaned.

Fig. 405 indicates the binding of the suction valve, by which a considerable decline is caused in the pressure at the beginning of the

suction, which is consequently shown by an increased projection in the commencement of the suction line. At the beginning of compression this defect makes itself felt by causing a delay in the latter, which effect is also shown on this diagram.

Fig. 406 shows leaking of the compressor valves. In this diagram the projections in the compression and suction line do not appear, but the compression line gradually merges into the pressure line, and the back expansion line passes gradually into the suction line. If the leak in the pressure valve is the predominant one, then the compression curve will be almost in a straight line and very steep; if, on the contrary, the leak in the suction valve is the predominant one, then the compression line will run a rather flat course.

Fig. 407 indicates that the piston is not well packed, and being leaky, the vapours are permitted to pass from one side of the piston to the other, thus causing a very gradual compression, and as a result a compression line having a flat course. On the other hand, a longer time will be taken before the suction line reaches its normal level on the return or backward stroke, inasmuch as the suction valve is prevented from opening until such time as the velocity of the piston becomes such, that the amount of vapours leaking past the piston is insufficient in amount to fill the suction space. The pressure then gradually diminishes and the suction valve begins to act, as is shown on the diagram.

It is to be understood that several of the defects above-mentioned may exist at the same time.

ABSORPTION MACHINES.

Liquid anhydrous ammonia is supplied in iron or steel drums or flasks in which it is contained at a pressure varying in accordance with the temperature of the liquid from 120 lbs. to 200 lbs. per square inch. This liquid is charged into the machine and is brought into contact with the substance to be cooled or frozen at a sufficiently low pressure to allow of its boiling point being lower than the temperature at which the substance to be treated has to be maintained. During normal working of an absorption machine the cold strong or rich liquor, or aqua ammonia, should contain about 60 per cent., and the hot poor or weak liquor, or aqua ammonia, about 20 per cent. of pure ammonia. This admits of calculating the amount of liquid required for a given amount of refrigeration. The pressure in the absorber is as a general rule maintained at about 15 lbs. per square inch, that in the generator

may be anything between 110 lbs. to 180 lbs. per square inch in accordance with the temperature of the condensing water. To ensure these conditions strong ammonia liquor has to be pumped from the absorber into the generator, the small pump used for this purpose being the sole part of the system in motion, and corresponding practically to the feed pump of a boiler. The strong or rich ammonia liquor is in as cold a condition as possible, and as its return in that condition to the generator would entail the consumption of more heat for evaporation, and a consequent larger expenditure of fuel, which entails expense, this strong ammonia liquor is first raised to as high a temperature as possible by passing it through an exchanger. In this latter the hot weak ammonia liquor passes from the bottom of the generator back to the absorber through a coil, the strong or rich ammonia liquor being conducted between the shell and the coil. The level of the liquor in the generator is maintained slightly above that of the heating coils. The ammonia gas driven off contains a certain amount of moisture, and it must be dried before passing to the condenser. This is effected in the rectifier, where the moisture in the gas is condensed by slightly heated condensing water and the gas merely cooled, the first returning to the analyser, and the second passing on to the top of the condenser to be condensed and liquefied. It is found advisable to further cool the weak liquor in a double pipe weak liquor cooler before its return to the absorber.

AMOUNT OF WATER REQUIRED IN REFRIGERATING APPARATUS.—

Vulcan Iron Works.

For each rated ton refrigerating capacity (twenty-four hours), allow $1\frac{1}{2}$ gals. of 70° Fahr. water per minute for ammonia condenser.

For each rated ton ice-making capacity (twenty-four hours), can system, with distilling and purifying apparatus, allow 3 to 4 gals. of 70° Fahr. water per minute for all purposes.

5 to 8 tons of ice can be produced for each ton of good coal consumed, depending upon the size and care of plant, &c.

DETERMINATION OF MOISTURE IN AIR (*Siebel*).

The moisture in the atmosphere may be determined by a wet bulb thermometer, which is an ordinary thermometer the bulb of which is covered with muslin kept wet, and which is exposed to the air, the moisture of which is to be ascertained. Owing to the evaporation of

the water on the muslin the thermometer will shortly acquire a stationary temperature which is always lower than that of the surrounding air (except when the latter is actually saturated with moisture). If t is the temperature of the atmosphere, and t^1 the temperature of the wet bulb thermometer in degrees Celsius, the tension e of the aqueous vapour in the atmosphere is found by the formula—

$$e = e^1 - 0.00077 (t - t^1) h,$$

e^1 being the maximum tension of aqueous vapour for the temperature t^1 as found in table and h the barometric height in millimetres.

If e_2 is the maximum tension of aqueous vapour for the temperature t , the degree of saturation H is expressed by—

$$H = \frac{e}{e_2}$$

and the dew point is also readily found in the same table, it being the temperature corresponding to the tension e .

PSYCHROMETERS.

Instead of the wet bulb thermometer alone it is more convenient to use two exact thermometers combined (one with a wet bulb and the other with a dry bulb, to give the temperature of the air), to determine the hygrometric condition of the atmosphere or of the air in a room. Instruments on this principle can be readily bought, and are called psychrometers. If they are arranged with a handle so that they can be whirled around, they are called "sling psychrometers." These permit a quicker correct reading of the wet bulb thermometer than the plain psychrometer, in which the thermometers are stationary and are impracticable at a temperature below 32° Fahr., while the sling instrument can be read down to 27° Fahr.

HYGROMETERS.

While the term hygrometer applies to all instruments calculated to ascertain the amount of moisture in the air, it is specifically used to designate instruments on which the degree of humidity can be read off directly on a scale without calculation and table. Their operation is based on the change of the length of a hair or similar hygroscopic substance, under different conditions of humidity.

The following table can be used to ascertain the degree of saturation or the relative humidity of air :—

RELATIVE HUMIDITY—PER CENT. (U.S. Weather Bureau.)

| t (Dry Ther.), | Difference between the Dry and Wet Thermometers ($t-t_1$), | | | | | | | | | | t (Dry Ther.), | | |
|------------------|--|------|------|------|------|------|------|------|------|------|------------------|------|------|
| | 0°·5 | 1°·0 | 1°·5 | 2°·0 | 2°·5 | 3°·0 | 3°·5 | 4°·0 | 4°·5 | 5°·0 | | 5°·5 | 6°·0 |
| 28 | 94 | 88 | 82 | 77 | 71 | 65 | 60 | 54 | 49 | 43 | 38 | 33 | 28 |
| 29 | 94 | 89 | 83 | 77 | 72 | 66 | 61 | 56 | 50 | 45 | 40 | 35 | 29 |
| 30 | 94 | 89 | 84 | 78 | 73 | 67 | 62 | 57 | 52 | 47 | 41 | 36 | 30 |
| 31 | 95 | 89 | 84 | 79 | 74 | 68 | 63 | 58 | 53 | 48 | 43 | 38 | 31 |
| 32 | 95 | 90 | 84 | 79 | 74 | 69 | 64 | 59 | 54 | 50 | 45 | 40 | 32 |
| 33 | 95 | 90 | 85 | 80 | 75 | 70 | 65 | 60 | 56 | 51 | 47 | 42 | 33 |
| 34 | 95 | 91 | 86 | 81 | 75 | 72 | 67 | 62 | 57 | 53 | 48 | 44 | 34 |
| 35 | 95 | 91 | 86 | 82 | 76 | 73 | 69 | 65 | 59 | 54 | 50 | 45 | 35 |
| 36 | 96 | 91 | 86 | 82 | 77 | 73 | 70 | 66 | 61 | 56 | 51 | 47 | 36 |
| 37 | 96 | 91 | 87 | 82 | 78 | 74 | 70 | 66 | 62 | 57 | 52 | 48 | 37 |
| 38 | 96 | 92 | 87 | 83 | 79 | 75 | 71 | 67 | 63 | 58 | 54 | 50 | 38 |
| 39 | 96 | 92 | 88 | 83 | 79 | 75 | 72 | 68 | 63 | 59 | 55 | 52 | 39 |
| 40 | 96 | 92 | 88 | 84 | 80 | 76 | 72 | 68 | 64 | 60 | 56 | 53 | 40 |

The hygrometer of Marvin is a sling psychrometer of improved construction.

Table giving weights of aqueous vapour held in suspension by 100 lbs. of pure dry air when saturated, at different temperatures, and under the ordinary atmospheric pressure of 29.9 in. of mercury (*Box and Lightfoot*).

| Temperature. | Weight of Vapour. | Temperature. | Weight of Vapour. |
|--------------|-------------------|--------------|-------------------|
| Fahr. degs. | Lbs. | Fahr. degs. | Lbs. |
| -20 | 0.0350 | 102 | 4.547 |
| -10 | 0.0574 | 112 | 6.253 |
| 0 | 0.0918 | 122 | 8.584 |
| +10 | 0.1418 | 132 | 11.771 |
| 20 | 0.2265 | 142 | 16.170 |
| 32 | 0.379 | 152 | 22.465 |
| 42 | 0.561 | 162 | 31.713 |
| 52 | 0.819 | 172 | 46.338 |
| 62 | 1.179 | 182 | 71.300 |
| 72 | 1.680 | 192 | 122.643 |
| 89 | 2.361 | 202 | 280.230 |
| 92 | 3.289 | 212 | Infinite |

N.B.—The weight in lbs. of the vapour mixed with 100 lbs. of pure air at any given temperature and pressure is given by the formula :—

$$\frac{62.3 E}{29.9 - E} \times \frac{29.9}{p},$$

where E = elastic force of the vapour at the given temperature, in inches of mercury (to be taken from tables),

p = absolute pressure in inches of mercury,

= 29.9 for ordinary atmospheric pressure.

ELECTRICAL TEMPERATURE TELL-TALES AND LONG DISTANCE THERMOMETERS.

At the West Smithfield Cold Meat Stores a system of electric temperature tell-tales, designed by Mr C. E. Vernon, were put in in 1896. These electrical thermometers were on the multiple-wire system. Six wires, in conjunction with a Breguet spring or compound coil of hard brass and steel connected by a suitable link to an index hand or pointer, were required for a range of 11° Fahr. with six points of contact with the instrument in the chamber, and a six-drop indicator in the engine-room. Eleven wires were required for a range of 20° Fahr., and it is evident that for a wide range the multiplicity of wires would form a serious objection.

On the three-wire system the same compound coil of hard brass and steel was used. Instead, however, of a connecting link and movable hand or pointer, the loose end of the coil had attached to it at a given distance from an electromagnet a small bar of iron, and by reason of the unequal expansion and contraction of the two metals the distance between the bar and the magnet will vary in accordance with the temperature, and the amount of current required to draw down the bar to the magnet will be measured by the ampere-meter. The construction of this latter is such that on the bar touching the magnet a second circuit would be completed and the hand of the ampere-meter stopped at a given point. The ampere-meter is calibrated and marked off into degrees Fahrenheit, and a wide range in temperature is obtainable with only three wires readable at any distance and accurate to within a degree.

A long distance thermometer which has been extensively used in cold stores is that devised by Mr A. P. Trotter. In this instrument a blind stem is placed alongside of the elongated capillary stem, the former having at its further end a scale tube corresponding exactly to that of the main thermometer. The action of this is that whatever variation in reading was produced by the varying temperatures passed through by the elongated capillary stem, the blind stem suffered like alterations of temperature, and a shifting scale adjusted by a thumb-screw was in this manner established by means of which the fluctuations of the main instrument were accurately compensated for.

THE THERMOGRAPH.

The thermograph or registering thermometer is a very useful instrument which enables a record to be kept of the exact temperature of a cold store. On an ordinary pattern of instrument the record paper or card is secured round a drum or cylindrically-shaped body, so arranged that it will be slowly rotated by a train of clock-work, which takes two weeks to run down, performing in this space of time one complete revolution. The diameter of the drum is $3\frac{3}{4}$ in. and the record fits it accurately, the ends butting.

Upon this record card or paper there rests gently a sloped pen holding about a drop of ink, this pen being suspended on a slender arm attached to the base of the instrument, and the mechanism being of such a nature that the slightest rise or fall of temperature will affect it, and will raise or lower the pen resting against the record paper or card upon the drum or cylinder.

The ink line will start from the top and thus indicate when the instrument was placed in the cold store or room, and the temperature will fall very rapidly at first and afterwards more gradually approximate itself to that of the store.

The record paper or card is ruled with horizontal lines showing the temperature in degrees, and with vertical lines showing the days for a period of two weeks, each day being divided into six watches of four hours each, viz., midnight, 4 and 8 A.M., noon, 4 and 8 P.M., and midnight again. At the termination of every two weeks, the record paper or card, now forming a thermograph chart, must be removed, the clock-work of the instrument be re-wound, and a new record paper or card placed in position on the drum or cylinder.

THE TELETHERMOMETER OR ELECTRICAL THERMOMETER.

The telethermometer or electrical thermometer is an instrument invented by Mr Chatwood and made by Messrs Nalder Brothers & Thompson, Ltd., London, for measuring the temperature of cold stores or rooms by means of electricity. The apparatus is of the resistance type and consists of two main parts, viz., a resistance or temperature coil of fine wire and an indicator. The former, calibrated and encased in metal tubes open at the ends, is placed at a number of suitable parts in the cold store or room, and the latter, together with a multiple circuit switch, in the office or wherever it is desired to take the readings, and are connected by lead covered wires carried along the walls. A fine wire resistance placed across the 250 volt supply mains admits of a current at 30 volts being obtained from the terminals on this resistance. The indicator is calibrated directly in degrees Fahrenheit, and as the multiple point switch is shifted from one contact to another the temperatures can be read off on the indicator dial. The instrument works on the Wheatstone bridge principle, the temperature coil being one of the arms, and the other arms and the galvanometer being contained in the indicator case. The galvanometer is of the moving coil type, so that when a voltage is applied to its terminals the indications are proportional to the change of resistance due to the variation of the temperature of the coil. The scale is practically evenly divided over the whole range, and, as before stated, is calibrated to read directly in degrees Fahrenheit or Centigrade. To operate the instrument a pressure of about 30 volts continuous current is required, and this can be obtained, as above mentioned, either by tapping from a high resistance placed across the

lighting mains or through a hand operated magneto generator. The instrument is rendered independent of the applied voltage by means of an electro-magnetic controlling device located within the case, and variations of the pressure of the mains, or of the speed of the magneto generator will be automatically compensated for by this device. The temperature of any required number of different rooms can be read with one indicator at any desired point, provided each room be provided with a temperature coil from which leads are carried to the indicator, and, moreover, as the instrument is a rapid dead-beat one, different temperatures can be read off successively without delay. The system is claimed to be simple, convenient, and accurate, also that a considerable saving of time can be effected by the use of the instrument when the temperatures of several different rooms have to be recorded at regular intervals.

The makers of this electrical thermometer guarantee the accuracy of the instrument to within a very small error.

LIGHTING COLD STORES.

It is desirable that daylight should not be allowed to enter a cold store, and therefore artificial light is usually resorted to, electric light being preferably employed, owing to there being practically an absence of heat therefrom.

Incandescent lamps should be always used inside the cold stores, but arc lamps may be placed, if desired, in the engine-room, and employed for the external lighting of the premises. Lower voltage lamps are the most durable, and serve the purpose quite as well as those of a higher voltage.

The mains should be kept as far as practicable in the corridors, and tinned cables of high conductivity and with rubber insulation should be employed.

Iron piping, steel conduits, or wood casing may be used for carrying the main cables, the latter being the cheapest both in cost of material and in fixing, and also lending itself more readily to any subsequent alterations that may become necessary. Steel conduits, however, possess several important advantages. The steel-armoured insulating conduit material now much used is installed in a similar manner to ordinary gas-pipe construction, the principal difference in electric piping being that specially insulated boxes, bends, elbows, &c., are substituted for the ordinary tees or angles of a gas-pipe system.

The use of the conduit system ensures a mechanically and electrically protective duct for the installation of the electric conductors.

When wood casing is used, the interior should be painted with asbestos paint, and the cover fixed with brass screws on each edge, not in the central fillet.

Iron piping has an internal lining of suitable insulating material, and is, as a rule, coated with a bituminous compound of some description intended to act as a preservative.

There are two systems of carrying out wiring now in use, viz., the tree system, and the distributing-board system.

In the first of these, or the tree system, two main cables are carried

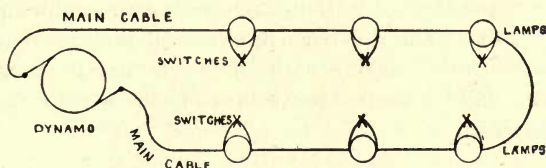

Fig. 408.—Diagram illustrating Arrangement of Electric Lighting on the Series Circuit System.

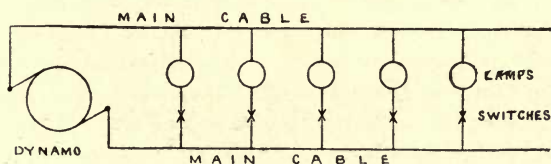

Fig. 409.—Diagram illustrating Arrangement of Electric Lighting on the Parallel Circuit System.

through the building, the branch circuits being all taken from these cables or mains. In the second, or distributing-board [system, a main switchboard is placed close to the dynamo, from which main switchboard cables are carried to supplementary distributing boards located at convenient points, from which the lamps are wired.

An obvious advantage of this latter plan is that all the joints are readily get-at-able, being at the distributing boards and fittings. The insulation of the cable is left completely intact.

In fixing wood casing all joints should be united, and no sharp edges or corners left for the cable to pass over. The casing is ordinarily secured by screws to the walls, floors, and ceilings, and either on the surface,

partially sunk, or sunk flush therewith. In very damp situations, however, the casing should be supported, so as to be clear of the surfaces, by means of small porcelain insulators.

The circuits may be arranged either on the series system or on the parallel arrangement, the latter being the most common, and the former being, as a rule, only employed where a number of arc lamps are used. The series circuit and parallel circuit are shown in the diagrams (Figs. 408 and 409), the dynamos, main cables, lamps, and switches being indicated thereon.

In the series circuit the current is maintained constant in value, the difference in pressure varying with the work on the circuit.

In the parallel circuit all the lamps are connected as separate paths between the two main leads, each path being quite independent of the other paths. The difference of electrical pressure is maintained constant, the current varying with the work that is on the circuit. The switching off of a lamp causes a break in the wires connecting the lamp to the circuit.

CHAPTER XXI

COST OF WORKING

Main Items of Expense—Absorption Machines—Compression Machines—Vacuum Machines—Cold-Air Machines—Cost of Ice-Making.

THE cost of producing cold with any of the hereinbefore-described machines must of necessity vary in different localities in accordance with the prices of material and labour, and even in the same district with the fluctuations in the market, consequently any estimates made thereof can only apply to the particular case in point, and in others can be taken as approximate only.

The main items of expense in the production of cold by artificial means are fuel and skilled and other labour for operating the machinery, and in the manufacture of ice, for handling the latter. The degree of economy of working to which the apparatus has been brought, and the point to which the operation thereof has been rendered automatic, will naturally tend to minimise the cost of the production of cold and of ice-making, and the latter will also vary inversely with the power of the machine, as the consumption of fuel and the number of attendants necessary to work the machinery do not increase in a ratio corresponding to the size thereof, and consequently those having the larger outputs require proportionately fewer operatives. The saving, moreover, under this latter head is the greatest in the more expensive skilled labour. For instance, an ammonia machine on either the absorption or compression principle, with a capacity of 1 ton of ice per twenty-four hours, requires the services of two engine-drivers and two labourers; whilst the same number of attendants can likewise work a 2 or a 5 ton machine, and the addition of a single labourer will be sufficient for either a $7\frac{1}{2}$, 10, or 12 ton machine, and of three labourers for a 28-ton machine. The same skilled attendants are sufficient for a machine having an output of 50 tons per twenty-four hours.

According to calculations made by Mr F. Colyer, M.Inst.C.E., in 1884, from observations of the working of a Pontifex-Wood ammonia absorption machine of a capacity of 20 tons of can ice per twenty-four

hours, the cost of making ice, taking coals at London price, was 4s. 9d. per ton. If, however, two machines were used the price would be reduced to 3s. 5d. per ton, and with coals at Glasgow price the cost would be further lowered, and would stand respectively at 3s. 7d. and 2s. 10d.

The cost of cooling water 10° by the same machine he estimated to be $\cdot 15$ of a penny per barrel cooled.

The calculations from which these figures were deduced include the cost of labour, coals, water, oil and sundries, repairs, loss of ammonia, 5 per cent. interest on capital invested, and an allowance of 4 per cent. for depreciation.

The cost of producing clear block ice in this country with an ammonia machine working on the absorption principle is given at a somewhat higher figure * by Mr Lightfoot, viz., for a machine of 15 tons capacity per twenty-four hours about 4s. per ton, and this estimate, moreover, is made on the assumption that good coals can be obtained at 15s. per ton, and is exclusive of any allowance for repairs and depreciation.

The cost of producing ice with a Pontifex-Wood improved ammonia absorption machine is stated by the makers to be, for a machine having a capacity of 24 tons per twenty-four hours, allowing for labour, coals, oil, chemicals, and water (taking coals at 10s. a ton and water at 6d. per 1,000 gallons), 2s. $0\frac{3}{4}$ d. per ton. With coals at 20s. a ton it rises, however, to 2s. $10\frac{1}{2}$ d. per ton. For a machine with a capacity of 15 tons per twenty-four hours, it is respectively, with coals at the above prices, 2s. $7\frac{3}{4}$ d. and 3s. $7\frac{3}{4}$ d. per ton. For a machine with a capacity of 9 tons per twenty-four hours, 3s. 4d. and 4s. $5\frac{1}{2}$ d. per ton. For a machine with a capacity of 6 tons per twenty-four hours, 4s. $5\frac{1}{2}$ d. and 5s. 8d. per ton. And for a machine with a capacity of 4 tons per twenty-four hours, 5s. and 6s. 3d. per ton.

According to Mr Lightfoot † the action of, and losses experienced in working an ammonia absorption machine are as follows:—

“Assuming the action of the economiser to be perfect—which, of course, is a condition never met with in practice—all the heat given out by the steam in the generator-coils would be found in the water issuing from the condenser, less that portion directly lost by radiation and conduction. In this case the total heat expended would be that required to vaporise the ammonia, and the water, which, in the form of steam, unavoidably passes off with the ammonia to the rectifier and condenser: plus the heat lost by radiation and conduction. In the

* *Proceedings, Institution of Mechanical Engineers*, 1886, p. 221.

† *Ibid.*, 1886, pp. 220, 221.

refrigerator the liquid ammonia in becoming vaporised will take up the precise quantity of heat that was given off during its cooling and liquefaction in the condenser, less the amount due to difference in pressure, and less also the small amount due to the difference in temperature between the vapour entering the condenser and that leaving the refrigerator. Again, when the vapour enters into solution with the weak liquor in the absorber, the heat taken up in the refrigerator is given to the cooling water, subject to slight corrections for differences of pressure and of temperature. Supposing there were no losses therefore, the heat given up by the steam in the generator, plus that taken up by the ammonia in the refrigerator, would be precisely equal to the amount taken off by the cooling water from the condenser, plus that taken off from the absorber. The sources of loss are: inefficiency of the economiser; radiation and conduction from all vessels and pipes that are above normal temperature; useless evaporation of water which passes into the rectifier and condenser; conduction of heat into all vessels and pipes that are below normal temperature; water passing into the refrigerator along with the liquid ammonia.

“It will have been seen that the heat demanded from the steam is very much greater in the absorption system than in the compression. This is chiefly due to the fact that in the absorption system the heat of vaporisation acquired in the refrigerator is rejected in the absorber; so that the whole heat of vaporisation required to produce the ammonia vapour prior to condensation, has to be supplied by the steam. In the compression system the vapour passes direct from the refrigerator to the pump, and power has to be expended merely in raising the pressure and temperature to a sufficient degree for enabling liquefaction to occur at ordinary temperatures. On the other hand, a great advantage is gained in the absorption machine by using the direct heat of the steam without first converting it into mechanical work; for in this way its latent heat of vaporisation can be utilised by condensing the steam in the coils, and letting it escape in the form of water. Each lb. of steam passed through can thus be made to give up some 950 units of heat; while in the steam-using being 2 lbs. of coal per indicated horse-power per hour, about 160 units only are utilised per lb. of steam, without allowance for mechanical inefficiency. In the absorption machine also the cooling water has to take up about twice as much heat as in the compression system, owing to the ammonia being twice liquefied, namely, once in the condenser and once in the absorber. It is usual to pass the condensing water first through the condenser and then through the absorber.”

The cost of ice-production with machines of the ammonia compression type is somewhat less on the whole than with those working on the absorption principle.

The estimate given by the Pulsometer Engineering Co. as the approximate amount per ton of clear or crystal ice is—cost of coals, 1s., all labour, including that of getting the ice out of the tanks, 1s. 3d., and cost of ammonia lost through leakage, &c., $\frac{1}{4}$ d. per ton of ice made, or a total cost of 2s. $3\frac{1}{4}$ d. per ton. If an allowance of, say, 10d. per ton be added to this for interest and depreciation, repairs to machinery, cost of water supply and sundries, this would increase the cost of production to about 3s. 2d. per ton.

Mr Lightfoot states* that one ton of coal is capable of producing as much as 12 tons of ice in well-constructed ammonia compression apparatus, having a capacity of 15 tons per twenty-four hours; and with coals at 15s. a ton, he estimates the cost of making ice by the ammonia compression system at about 3s. 9d. per ton for a production of 15 tons per twenty-four hours, exclusive, however, of any allowance for repairs and depreciation.

The estimate given for the total cost of ice per ton, made by a Frick ammonia compression machine, is, for a daily production of 15 tons, 5s. 2d. per ton of ice. The calculation, however, is got out at the much higher rate of wages paid in America, and if due allowance be made for this, and also for the falling off in efficiency of the machine, due to the greater heat of the climate in summer, the cost per ton in this country would probably be something under 4s. If the capacity of the machine be 100 tons of ice per day, the cost per ton falls to 3s. 11d., or allowing for the larger item for labour, about 2s. 10d. here.

In an ether compression machine Mr Lightfoot accounts for the work as follows: †—Friction. Heat rejected during compression. Heat acquired by the refrigerating agent in passing through the pump. Work expended in discharging the compressed vapour from the pump. Against this he sets the work done by the vapour in entering the pump. Assuming that vapour alone enters the pump, the heat rejected in the condenser he states to be:—Heat of vaporisation acquired in the refrigerator, with the connection necessary for difference in pressure. And the heat acquired in the pump, less the amount due to the difference between the temperature at which liquefaction occurs and that at which the vapour entered the pump, and less also the amount lost by radiation and conduction between the pump and the condenser.

* *Proceedings, Institution of Mechanical Engineers*, 1886, p. 221.

† *Ibid*, 1886, p. 214.

The mechanical work expended in compressing ammonia is to be accounted for in a precisely similar manner to that expended in the compression of ether.

Notwithstanding, however, that the degree of compression is so much greater with ammonia than with ether, the energy expended in the compression, heating, and delivering of the gas is less, owing to the much smaller weight of ammonia required to produce a given refrigerating effect, the weights being in the reverse ratio of the heats of vaporisation, or as 1 to 5.45. For this reason the cost of making ice with ether is far higher than with ammonia, and assuming the coal consumption per I.H.P. to be 2 lbs. per hour and the price of coals 15s. a ton, the total cost of producing transparent block ice in this country on the ether system would be about 5s. per ton, exclusive of any allowance for repairs and depreciation. The production of ice would be about 8.3 tons per ton of coal consumed.

On the other hand, however, as already mentioned, ether machines, by reason of their low working pressures in the condensers, offer considerable advantages in hot climates, especially in the case of machines with small outputs.

The expense of producing ice with the Tellier and Pictet machines is about the same. The results obtained with Pictet's special liquid (combination of carbon dioxide and sulphur dioxide) is stated to equal a production of 35 tons of ice per ton of coal, but this is in all probability far in excess of any result obtained in actual working.

It will be obvious that the arrangement made for the use of any particular machine acting on the principle of the abstraction of heat by the evaporation of a separate refrigerating agent of a more or less volatile nature, must have a very considerable effect upon its economical working, and it is doubtless owing to the superiority of the fixing and manipulation of the installation that so much better results are occasionally obtained in one case than in another, as, these things being equal, all first-rate machines of this class are about the same in point of economy. In relation to this it must also be borne in mind that the thickness of the blocks of ice that are being made exercises an important influence upon the time occupied in their production, for whereas a block 3 in. thick can be frozen in eight hours, a block 9 in. in thickness will require thirty-six hours. The time varying also, of course, more or less with the temperature of the brine.

The cost of making a ton of opaque and porous ice with a vacuum machine such as the Windhausen is estimated * by Dr Hopkinson at 4s.

* *Journal of the Society of Arts*, 1882, vol. xxi., p. 20.

The amount of water required (including that used for cooling purposes) is stated * by Mr Pieper to be from 10 to 12 tons per ton of ice produced, and the fuel consumption 1 ton of coal for every 12 tons of ice. The fuel is required for the generation of steam to drive the vacuum pump and the air pump of the concentrator. The total heat which must be abstracted to produce a ton of ice from a ton of water at a temperature of 60° Fahr. is 382,144 units. The Windhausen machine is heavy, and takes up a considerable floor space, and the necessary outlay for keeping it in an efficient state of repair, even under the most favourable circumstances, must be high.

The cost of making opaque ice by means of the Harrison (1878) patent vacuum apparatus would undoubtedly be lower than with the Windhausen machine, as the larger part of the friction, which forms a very considerable item of the loss in the latter, is got rid of, and a corresponding saving of fuel is thus effected. The expenditure of fuel for concentrating the acid is also entirely eliminated, much less water is required for cooling purposes, and the first cost and subsequent outlay for repairs, &c., are likewise much less. It is stated that the inventor expected to be able to produce opaque ice on a large scale at a cost of about 1s. per ton.

The outlay per ton of ice made on the system of abstracting the heat by the rapid melting or liquefaction of a solid is the greatest, and so much so that for producing ice on a commercial scale in this climate it is completely out of the running. The cost of making 15 tons of ice per twenty hours, with an apparatus working on a substantially similar principle to that of Sir William Siemens', is stated to be 7s. per ton with good coals at 15s. a ton, and not making any allowance whatever for depreciation, interest, repairs, &c.

This estimate, moreover, is based upon the erroneous assumption that 1 lb. of coal is capable of evaporating 20 lbs. of water, and it is undoubtedly far too low. According to Mr Lightfoot: †—

“Nearly the whole of the coal is used for evaporating the water in recovering the salt, the quantity being given at $2\frac{1}{2}$ tons of coal for every 15 tons of ice. If, however, this has been calculated on an evaporative duty of 20 lbs. of water per lb. of coal, the amount actually used will probably be about 5 tons of coal, which would make the cost per ton of ice 9s. 3d. instead of 7s. On the other hand, it must be remembered that under certain climatic conditions much of the water could be evaporated in the open air, without the use of fuel,

* *Transactions of the Society of Engineers*, 1882, p. 145.

† *Proceedings, Institution of Mechanical Engineers*, 1886, p. 204.

in which case the coal consumption, and therefore the cost of ice production, would be greatly lessened."

As regards the capacity, &c., of cold-air machines, those of the Haslam type vary from an ice equivalent of one-third of a ton, requiring 4 I.H.P. at average speed, or 9 I.H.P. at maximum speed, and delivering 2,000 cub. ft. per hour (capacity of compressor in cubic feet per hour, 2,500), up to an ice equivalent of 60 tons, requiring 460 I.H.P. at average speed, or 566 I.H.P. at maximum speed, and delivering 300,000 cub. ft. of air per hour (capacity of compressor in cubic feet per hour, 353,000). This latter machine is of the quadruple duplex condensing type.

It has been stated * by Mr Lightfoot that with the best machines of large size then (1886) made, a weight of 1,000 lbs. of air per hour could be reduced from 60° above to 80° below zero, the cooling water being at 60° Fahr., with an expenditure of about 18 I.H.P. That is to say, that an abstraction of 916 units of heat is effected to each pound of coal used, with an engine consuming 2 lbs. of coal per I.H.P. per hour.

The results of later test experiments made with Messrs F. & W. Cole's "Arctic" dry cold-air machines will be found on page 244.

For Haslam's formula to enable the amount of air delivered by a cold-air machine per hour to be ascertained, the revolutions and size of the compressor being known, see page 245.

COMPARISON OF COAL CONSUMPTION BY VARIOUS MACHINES
(Gardner T. Voorhees).

| | Net Tons of Ice, per Ton of Coal. | Per cent. of Ice by Absorption Machine. |
|--|---|--|
| Compression, simple Corliss engine, non-condensing | 6·1 | ... |
| Compression, compound Corliss engine, non-condensing - - - - - | 8·3 | ... |
| Absorption, liquor pump and auxiliaries not exhausting into generator, simple non-condensing engine - - - - - | 10·0 | ... |
| Compression, compound condensing engine - - - - - | 11·2 | ... |
| Absorption, liquor pump and all auxiliaries exhausting into generator, simple Corliss engine, non-condensing - - - - - | 13·3 | ... |
| Compression and absorption, simple Corliss engine, non-condensing - - - - - | 13·4 | 67·5 |
| Compression and absorption, compound engine, non-condensing - - - - - | 16·0 | 60·8 |

The following tables giving the approximate cost of ice-making in the United States are respectively by the Frick Co. and the Triumph Ice Machine Co. :—

* *Proceedings, Institution of Mechanical Engineers, 1886, p. 230.*

ICE MANUFACTURE.—APPROXIMATE COST OF OPERATING ICE FACTORIES (FRICK CO., U.S.).

| Tons Ice per Day. | Engineers \$1.50 to \$5.00 per Day. | Oilers \$1.25 per Day. | Firemen \$1.25 per Day. | Tankmen and Labourers \$1.00 per Day. | General Helpers \$1.25 per Day. | Coal 15 cts. per Cwt., or \$3.00 per Ton. | Oil Waste Lights and Sundries. | Daily Operating Expenses. | Ice per Ton. |
|-------------------|-------------------------------------|------------------------|-------------------------|---------------------------------------|---------------------------------|---|--------------------------------|---------------------------|--------------|
| 1 | 2 \$3.00 | ... | ... | ... | ... | 500 | \$0.50 | \$4.25 | \$4.25 |
| 2 | 2 3.00 | ... | ... | ... | ... | 1,000 | 0.50 | 5.00 | 2.50 |
| 4 | 2 3.00 | ... | ... | 1 \$1.00 | ... | 2,000 | 0.50 | 7.50 | 1.88 |
| 6 | 2 3.50 | ... | ... | 1 1.00 | ... | 2,700 | 0.50 | 9.05 | 1.51 |
| 10 | 2 3.50 | ... | ... | 1 1.00 | ... | 4,500 | 0.75 | 12.00 | 1.20 |
| 15 | 2 3.75 | ... | ... | 2 2.00 | ... | 6,700 | 1.00 | 16.80 | 1.12 |
| 20 | 2 3.75 | ... | ... | 2 2.00 | ... | 8,000 | 1.00 | 18.75 | 0.94 |
| 25 | 2 4.00 | ... | 2 \$2.50 | 2 2.00 | ... | 8,400 | 1.10 | 22.20 | 0.89 |
| 30 | 2 4.00 | ... | 2 2.50 | 2 2.00 | ... | 9,500 | 1.25 | 24.00 | 0.80 |
| 35 | 2 4.00 | ... | 2 2.50 | 2 2.00 | ... | 10,800 | 1.50 | 26.20 | 0.75 |
| 40 | 2 4.00 | ... | 2 2.50 | 3 3.00 | ... | 11,500 | 1.75 | 29.00 | 0.73 |
| 50 | 1 2.75 | ... | 2 2.50 | 4 4.00 | ... | 14,300 | 2.00 | 34.45 | 0.69 |
| 60 | 2 5.00 | 1 \$1.25 | 3 3.75 | 4 4.00 | ... | 16,000 | 2.25 | 40.25 | 0.67 |
| 75 | 2 5.00 | 1 1.25 | 3 3.75 | 4 4.00 | 1 \$1.25 | 20,000 | 3.00 | 48.25 | 0.65 |
| 100 | 2 5.50 | 2 2.50 | 4 5.00 | 6 6.00 | 1 1.25 | 25,000 | 4.00 | 61.75 | 0.62 |

COST OF WORKING.

APPROXIMATE COST OF ICE-MAKING (TRIUMPH ICE MACHINE Co., U.S.).

| Tons Ice per Day. | Engineers \$2.00 to \$5.00 per Day. | Night Engineer, Oilers \$1.50 to \$2.50 per Day. | Or Firemen \$1.50 per Day. | Tankmen and Labourers \$1.50 per Day. | Pipe Fitter or Machinist \$2.50 per Day. | Office Expenses, B.K. \$1.00 to \$2.50 per Day. | Coal \$2 per Ton. | Oil, Waste, Light & Sundries. | Daily Operating Expenses. | Ice, per Ton. |
|-------------------|-------------------------------------|--|----------------------------|---------------------------------------|--|---|-------------------|-------------------------------|---------------------------|---------------|
| 1 | \$2.00 | ... | ... | ... | ... | ... | Lbs. 1,000 | \$0.25 | \$3.25 | \$3.25 |
| 2 | 2.00 | ... | ... | ... | ... | \$1.00 | 1,400 | 0.25 | 4.65 | 2.32 |
| 2½ | 2.00 | ... | ... | ... | ... | 1.00 | 1,500 | 0.25 | 4.75 | 1.90 |
| 3 | 2.00 | ... | ... | ... | ... | 1.00 | 1,800 | 0.40 | 5.20 | 1.73 |
| 4 | 2.00 | ... | ... | ... | ... | 1.00 | 2,200 | 0.50 | 5.70 | 1.42 |
| 5 | 2.00 | \$1.50 | ... | ... | ... | 1.00 | 2,500 | 0.50 | 7.50 | 1.50 |
| 7 | 2.50 | 1.50 | ... | ... | ... | 1.50 | 3,100 | 0.85 | 10.70 | 1.52 |
| 8 | 2.50 | 1.75 | ... | \$1.25 | ... | 1.50 | 3,300 | 0.90 | 10.95 | 1.36 |
| 10 | 2.50 | 2.00 | ... | 1.25 | ... | 1.70 | 3,600 | 1.00 | 13.10 | 1.31 |
| 12 | 2.50 | 2.00 | ... | 2.50 | ... | 1.75 | 4,800 | 1.25 | 14.80 | 1.23 |
| 15 | 2.75 | 2.00 | ... | 2.50 | ... | 1.75 | 5,000 | 1.25 | 18.25 | 1.21 |
| 20 | 2.75 | 2.00 | \$3.00 | 3.00 | ... | 1.75 | 6,000 | 1.50 | 20.60 | 1.03 |
| 25 | 2.75 | 2.00 | 3.00 | 3.00 | ... | 1.75 | 7,200 | 1.50 | 21.20 | 0.88 |
| 30 | 3.00 | 2.00 | 3.00 | 3.00 | ... | 2.00 | 9,000 | 2.00 | 24.00 | 0.80 |
| 35 | 3.00 | 2.00 | 3.00 | 3.00 | ... | 2.00 | 12,300 | 2.00 | 27.30 | 0.78 |
| 40 | 3.00 | 2.00 | 3.00 | 3.00 | ... | 2.50 | 13,300 | 2.50 | 30.80 | 0.77 |
| 45 | 6.00 | 2.00 | 3.00 | 4.50 | ... | 2.50 | 13,600 | 2.50 | 34.10 | 0.75 |
| 50 | 6.00 | 2.50 | 3.00 | 4.50 | ... | 4.00 | 14,000 | 2.50 | 36.50 | 0.73 |
| 60 | 6.00 | 2.50 | 3.00 | 4.50 | ... | 4.00 | 16,700 | 2.50 | 43.20 | 0.72 |
| 65 | 6.00 | 2.50 | 3.00 | 6.00 | \$2.50 | 4.00 | 17,800 | 3.50 | 46.80 | 0.70 |
| 70 | 7.00 | 2.50 | 3.00 | 6.00 | 2.50 | 4.00 | 19,000 | 3.50 | 49.00 | 0.70 |
| 90 | 8.00 | 2.50 | 4.00 | 7.50 | 5.00 | 5.00 | 25,000 | 5.00 | 63.00 | 0.70 |
| 100 | 9.00 | 4.00 | 5.00 | 9.00 | 5.00 | ... | 28,500 | 5.00 | 68.00 | 0.68 |

CHAPTER XXII

THE PRODUCTION OF VERY LOW TEMPERATURES

Early Investigators and Experimenters—The Cascade System—The Regenerative Method—Properties of Liquid Air—Physical Constants of Liquefied Gases.

EARLY INVESTIGATORS AND EXPERIMENTERS.

The Cascade System.

THE first experimenters in the liquefaction of gases were Mouge and Clouet before 1800, who succeeded in liquefying sulphur dioxide; Northmore in 1805, who liquefied chlorine and sulphurous acids; Faraday, 1823, who liquefied chlorine sulphuret of hydrogen, carbon dioxide, nitrous oxide, cyanogen, ammonia, and hydrochloride acid. Habrier, Nateur, Andrews, and Siemens, the latter making, in a provisional application filed in 1857, the suggestion that refrigeration might be produced by expanding a compressed gas either in a cylinder doing work or freely to a lower pressure, and using this cold gas to cool before expansion the gas coming to the apparatus. This, it will be seen, is the basis upon which the latest investigators have proceeded, and which has admitted in the closing years of the last century of the liquefaction of all gases being effected.

In 1878 Cailletet and Pictet, working quite independently of each other, succeeded in liquefying certain of the so-called permanent gases.

The method employed by the first was to compress the gas under very high pressure, cool it moderately, so that it was still above its critical temperature, and then allow it to expand suddenly by opening a cock or valve by which the pressure on the gas was relieved, doing work against a column of mercury which formed the equivalent of a piston for compressing the gas. In this manner the gas cooled itself, the expansion being sudden and almost adiabatic, and the temperature was reduced below the critical point, whilst the pressure was still sufficiently high to liquefy the gas at the temperature which it had then acquired.

Cailletet in the above manner experimented with various gases, amongst others nitrous oxide or laughing-gas, acetylene, and carbon monoxide, and succeeded in obtaining a mist of hydrogen. He was the first to use liquid ethylene as a cooling agent.

The second, or Pictet, on the other hand employed what has been styled the cascade or successive cycle system, and is described by Professor Ewing as follows: *—

“The general idea of this method is illustrated in Fig. 410. Imagine a refrigerating agent, such as carbonic acid, to have been

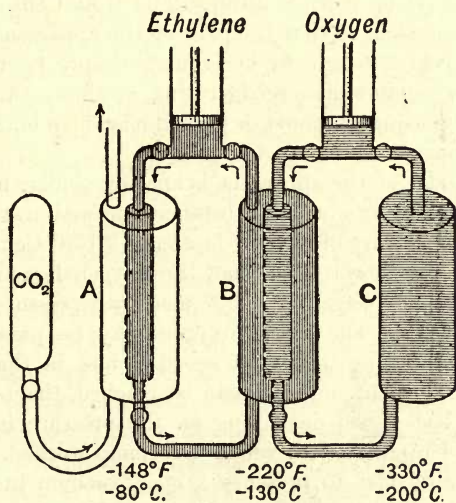

Fig. 410.—Diagram illustrating the Cascade or Successive Cycle System of producing Very Low Temperatures.

compressed and to expand through a valve into the chamber A, where it evaporates. In the example, as sketched, it is evaporating into the atmosphere. When carbonic acid evaporates freely to the atmosphere, it falls to a temperature of about -80° Cent. It could be made to go 30° or more lower by using an air pump to preserve a partial vacuum in the chamber; but, assuming the pressure A to be atmospheric, the temperature then will be about -80° Cent. Now, we may use this as the condensing temperature of some other volatile material. The material which is indicated in the sketch is ethylene, which was not used by

* *Journal of the Society of Arts*, 17th September 1897.

Pictet, but has come into use subsequently and has done good service in the hands especially of Professor Dewar. It forms a convenient intermediate link between the comparatively easily liquefiable carbonic acid and the much more difficult oxygen. Ethylene has a critical temperature of -10° Cent., and needs only moderate pressure to liquefy it when exposed to a temperature of -80° Cent. It is pumped at the necessary pressure into the inner vessel at A, and is there liquefied and passes through an expansion valve to the outer vessel at B, where it evaporates. The pressure in B is supposed to be kept at something not much over 1 in. of mercury, and in that case the temperature reached by the ethylene in evaporating will be -130° Cent. After expansion it is re-compressed, so that the part of the apparatus in which the ethylene is carried through its cycle may simply be regarded as a separate vapour compression refrigerating machine, the same as the ordinary machine using ammonia or carbonic acid; B is the refrigerator and A is the condenser.

“The remainder of the apparatus is another similar machine, using in this case oxygen as its working substance, and with B as its condenser. The critical temperature of oxygen is about -150° Cent., and as the temperature in B is lower than that, the oxygen liquefies when compressed into the inner vessel at B. A moderate pressure of 20 or 30 atmospheres suffices. The liquid oxygen may be passed through a valve and evaporated again in the vessel C, and in that way a temperature of -200° Cent. or lower can be reached, the temperature, of course, in this last vessel depending on the pressure in it, and consequently on the rapidity with which the pump worked. By working the pump tolerably fast to preserve a good vacuum in C, we can get down to something like -220° , or even -225° , Cent., a temperature which is no very long way above the absolute zero -273° Cent. In Pictet's cascade of successive cycles, the substances used were sulphurous acid and carbonic acid. The ethylene is a useful addition, as giving readily a temperature considerably below the critical point of oxygen. Without it, however, Pictet succeeded in liquefying oxygen by the device of letting it suddenly escape when under high pressure, and after being cooled as far as the carbonic acid would cool it.”

Further experiments, made during the next decade by the two Polish chemists, Wroblewski and Olszewski, working together and using Cailletet's type of apparatus, and latterly Pictet's cascade system, for cooling the compression tube, confirmed the results obtained by Cailletet and Pictet on hydrogen in 1884.

In this year (1884) Professor Dewar demonstrated at the Royal

Institution that liquid air could be produced by the use of solid carbon dioxide and nitrous oxide as cooling agents, giving -184° Fahr. (-120° Cent.). With a compression to 200 atmospheres, and subsequent expansion, about 5 per cent. of the air compressed was liquefied.

Professor Dewar also devised the vacuum flasks for holding liquid gases which bear his name, and which consist of two glass walls with a sealed space between from which the air has been completely exhausted, and which consequently acts as the best possible insulator. By the addition to the vacuum-jacket of a film of mercury spread over the surface of the glass on the inner side of the outermost wall, a bright surface is produced which reduces the absorption of heat by the latter, and permits much less radiation to pass through. This vacuum vessel enables the rate of evaporation of a liquid gas to be reduced from one-fifth to one-sixth of that which would take place in the open air, and if the inner wall be coated as above described with mercury to form a heat mirror, the heat evaporation will then be only from one-twentieth to one-thirty-third that of the free rate. Until quite recently these flasks were the means by which liquid gases were handled and maintained in a static form.

Subsequently Olszewski, after Wroblewski's death in 1888, replaced the glass tube of Cailletet by a steel one fitted with a stop-cock, and obtained enough liquids to be handled in Dewar flasks.

Discarding after a time the Cailletet apparatus, as altered by Wroblewski, Dewar employed the Pictet apparatus, using, however, pumps to compress the gases previously made, and force them into the liquefying chamber, and he also employed ethylene in place of carbon dioxide, placed the draw-off cock within the cooling chamber, and still later adopted the regenerative principle suggested by Siemens, for cooling the chamber in the case of hydrogen liquefaction. In 1895 Dewar demonstrated that air in the liquid form could be frozen to a jelly-like solid by the expansion method, this jelly proving to be a mass of nitrogen with the liquid oxygen of the air contained in the interstices; this solid air melts instantly on contact with the atmosphere. In 1896 he effected the production of a jet of liquid hydrogen by means of the expansion of the cooled and compressed gas, and by the use of this hydrogen jet, oxygen and air were frozen to a solid white mass. In 1898 Dewar succeeded in collecting hydrogen in a static condition, and in keeping it in this form by the use of one of his bulbs at a temperature of -396.4° Fahr. (-238° Cent.), only 64° Fahr. above the absolute zero.

Amongst other workers in this field must be mentioned Professor

Onnes of Leyden, and Moissau, the latter investigator together with Dewar having succeeded in liquefying fluorine, the last of the elements to yield.

A considerable amount of attention, it is true, was devoted to the production of liquid air by the above-mentioned investigators, especially by Professor Dewar, but they were primarily interested in the scientific investigation of the properties of the elementary gases, and the former has been more particularly dealt with by Linde, Hampson, and Tripler, who have all been experimenting especially with a view to the simplification and cheapening of the production of liquid air in order that it might be made on a commercial scale, and they have all been working on the lines of direct regenerative action which was proposed by the late Sir William Siemens forty-four years ago. In this direction it should be stated that Professor Dewar had also been working, combining cooling with a separate fluid, his experiments being, however, on a smaller scale suitable for a chemical laboratory.

THE REGENERATIVE METHOD.

As has been already mentioned, Siemens was the first to use the regenerative process, and in the specification of the provisional application already referred to he describes the employment of an interchanger to extract cold from the air already cooled by the refrigerating machine, and thereby to cool the air which is on its way to be expanded. Siemens especially pointed out that theoretically, at least, no limit existed to the degree of cold which could be produced by the use of such an interchanger, and after giving an example of the temperatures that might be expected in a particular instance, he says: "These temperatures are mentioned, not as absolute temperatures, but to show that the principle of the invention is adapted to produce an accumulated effect or an indefinite reduction of temperature."

Siemens' idea, observes Professor Ewing, was that the compressed air should pass through this interchanger, and should then be caused to do work in an expansion cylinder. This expansion would chill it, and it would then pass again through the interchanger, giving up its cold through the interchanger to the next succeeding supply of compressed air. The effect would be to make each fresh supply, on its way to the expansion cylinder, a little colder than the last. The cumulative fall in temperature resulting from this would only be limited by accidental losses due to conduction of heat from outside and to heat developed from friction within the machine.

In 1885 Solway took out a patent for an apparatus and process for producing, applying, and keeping up extreme temperatures by means of a regenerative method somewhat akin to that of Siemens, only that he employed a regenerator instead of an interchanger. With this apparatus Solway succeeded in reaching a temperature of about -95° Cent., at which he found the losses of cold balanced the gains.

In 1892 Windhausen obtained a patent for an apparatus for the production of extreme degrees of cold with an interchanger substantially similar to that of Siemens, but employed in combination with an expansion cylinder. With this he obtained about the same degree of temperature as Solway, and this apparatus is said to be now in use on a commercial scale for such processes as the extraction of benzol from the mixed gases which are given off by the distillation of coal.

The particular workers in this field, however, who have aimed at the simplification and cheapening of the production of liquid air, so that it might be made commercially useful, are, to take them in the order of their applications for patents, Tripler, Hampson, and Linde. Tripler's English patents were filed in 1891, Dr William Hampson's on the 23rd May 1895, and Dr Linde's three weeks later in the same year. A good deal of discussion has taken place as to which of these three should have assigned to them the real credit of having first produced a practical machine. It is averred by some that the apparatus described by Tripler was impracticable, and by others that Hampson's provisional specification was very brief, and so vague as to indicate but little. It certainly appears that the first to produce a practical working apparatus was Dr Linde, although he was the last to proceed to the Patent Office for protection; it is on record that his apparatus, in a practical and workable form, was produced in the summer of 1893. Mr Tripler has been refused a patent by the U.S. Patent Office.

The principle of the regenerative method of producing very low temperatures is, says Mr A. L. Rice, in a paper read before the American Society of Mechanical Engineers, December 1899, a perfect gas expanding to do work loses heat; if this cooled gas be exhausted, so as to jacket the pipe through which the incoming gas enters, it will cool that incoming gas; the process is cumulative without limit, if the machinery is frictionless and insulated against heat from the surrounding objects. Solway built a machine on this principle, but was unable to get lower than -139° Fahr. (-95° Cent.), on account of the heat due to the friction of the pistons and to conduction.

In a perfect gas no lowering of the temperature would result from

lowering of the pressure by free expansion, but none of the so-called gases are perfect, and all are cooled somewhat by expansion through an orifice. Joule and Kelvin found that with air the fall of temperature is about 45° Fahr. ($\frac{1}{4}^{\circ}$ Cent.), for each atmosphere difference of pressure at the orifice at ordinary temperatures, and that the effect increases as the temperature falls, because the gases are coming more nearly to the vaporous state. If, then, air be compressed to a high pressure, and be allowed to expand through a small orifice, it will become considerably cooled, and may be used to cool the incoming air, which,

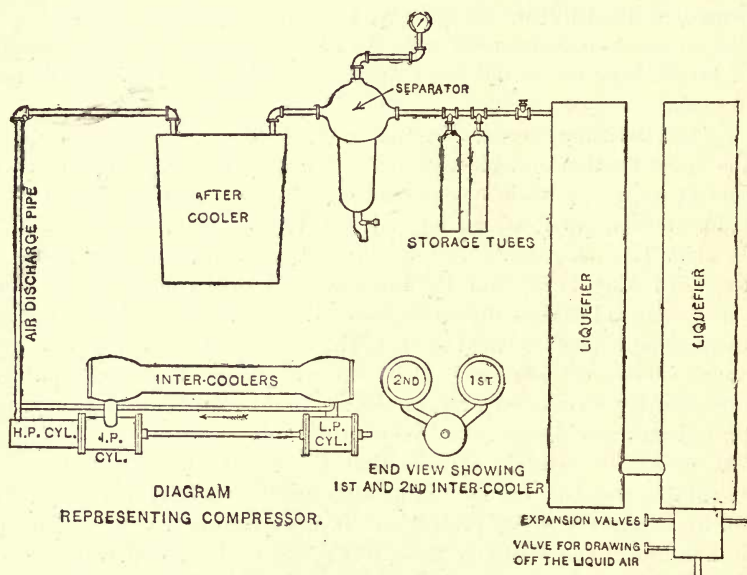

Fig. 411.—Diagram illustrating Tripler's Apparatus for the Production of Very Low Temperatures by the Regenerative Method.

in turn, will lose heat by expansion. The process may be carried on until some of the air, on or before leaving the orifice, is liquefied.

Mr Tripler's apparatus is shown in Fig. 411, and, as described by Mr Rice, "consists of a three-stage compressor, drawing air directly from the atmosphere, and driven by a steam engine. The air is taken first into the low-pressure cylinder, where it is compressed to 65 lbs. per square inch. It is then sent through an intercooler to reduce the temperature to that of the atmosphere, and taken into the intermediate-pressure cylinder; from that, at a pressure of 400 lbs., it is taken

through a second intercooler to the high-pressure cylinder, where it is forced up to 2,000 to 2,500 lbs., and thence sent to the after-cooler to be reduced again to the temperature of the atmosphere. The air is passed through a separator to take out all moisture, and then passes to storage tubes in which compressed air, not in the liquid form, may be kept. The liquefier is Mr Tripler's special invention. This takes the air from the separator, and by expansion through a coil of pipe and a small orifice, cools it to a low temperature. It passes up around the coil of pipe, cooling the air inside, and thus gives the regenerative action. The expansion valve is placed at a little distance above the bottom of the coil, so that some liquid air collects in the bottom of the latter, and thus serves to further cool the air as it comes to the expansion cock. The air which is to be drawn off collects in the liquefier just below the expansion valve, and may be drawn off at will. The expanded air escapes to the atmosphere after having been used to cool the coil of the liquefier. The capacity of the present plant is 2 or 4 gals. per hour, and the ice will begin to liquefy in fifteen minutes after the starting up. No data are available as to the power used in the compression."

The provisional specification of Dr William Hampson's 1895 patent was, as above mentioned, extremely brief, and the following is the text *in extenso* :—

"The usual cycle of compressing, cooling and expansion, is modified by using all the gas after its expansion, to reduce as nearly as possible to its own temperature the compressed gas which is on its way to be expanded. With this object all the expanded gas surrounds the pipe or pipes of compressed gas through all their length from the point of expansion to the point of normal temperature, and the length of pipe is sufficient to allow of the fullest possible interchange of temperatures between the compressed and expanded gas."

In a subsequent patent the improved apparatus shown in vertical and horizontal sections in Figs. 412 and 413 is described. In this apparatus the interchanger is made with a tube or tubes coiled into spirals, the convolutions of which are separated by very narrow spaces, and with the coils lying one upon the other. The space between the tubes does not exceed $\frac{1}{10}$ in. The gas after compression is purified by caustic potash or the like. The vacuum vessel 7 is supported by a cap 2 inside concentric glass tubes mounted between rings 3 and 5 held by a frame 4. Insulating or tight joints may be made at 5, 6, 7, 8. Cold carbonic acid or the like is passed on to the coils in the neigh-

bourhood of the expansion joint, and thence over their other parts before beginning expansion of compressed gas, and the arrangement

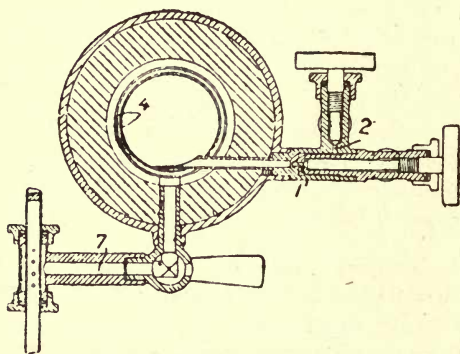
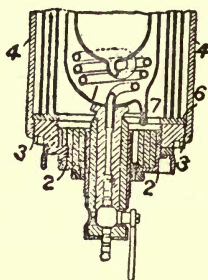
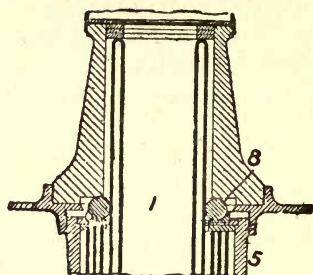

Figs. 412 and 413.—Hampson's Apparatus for the Production of Very Low Temperatures by the Regenerative Method. Vertical and Horizontal Sections.

shown in Fig. 413 is used for supplying the cold carbonic acid free from solid particles. In this, the gas expands from the valve 7, which is kept at a proper temperature by a stream of warmer gas from the valve 2, and then any solid material is removed by filtering material 4 from the vapour which is led away by the pipe, &c., 7.

Fig. 414 represents the 1898 type of the Linde apparatus, as depicted in Mr Rice's paper, and which apparatus only differs in a few minor details from that made in 1893. It has been already stated that the fall of temperature is proportional to the difference of pressures at the orifice, and this difference should, therefore, be large; the work required to compress the air again will depend upon the ratio of the pressures, that is to say, upon the ratio of compression, and should be as small as possible. This necessitates that both pressures be high for the most economical working, and, therefore, Linde works his machine between 200 atmospheres and

and, therefore, Linde works his machine between 200 atmospheres and

16 atmospheres for all the air by expanding through the valve marked *a*. One-fifth is then expanded to 1 atmosphere through the valve *b* so as to cool it still further, and about one-fourth of this amount is condensed. The expanded air is sent back in the outer pipes as shown, the part which is at 16 atmospheres to the compression pump, and the rest to the atmosphere. *f* is a separator and *g* a freezing

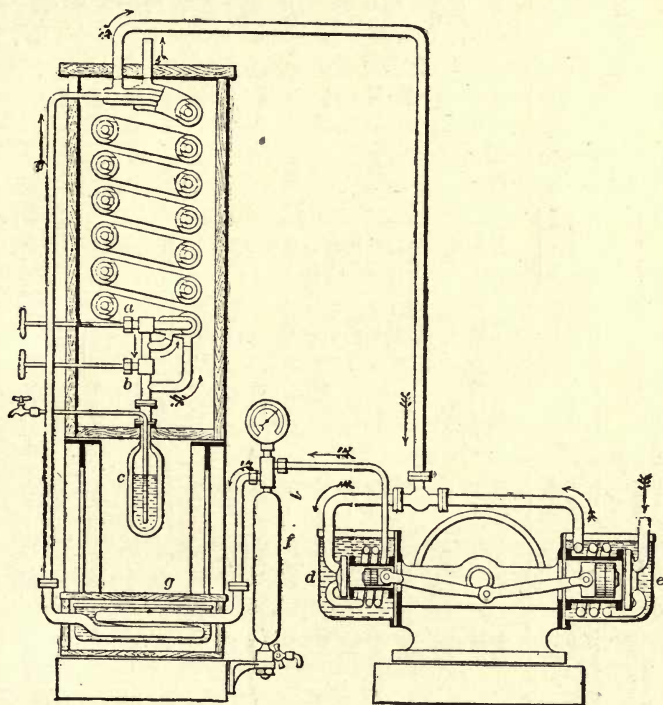

Fig. 414. —Linde's Apparatus for the Production of Very Low Temperatures by the Regenerative Process. Sectional Elevation.

bath, both being used to remove the moisture from the air. *d* is the compression pump, and *e* a pump for supplying at 16 atmospheres as much air as escapes at *b*. *c* is the receptacle for the liquid air. In the earlier form of the machine none of the air was expanded below 50 atmospheres, and the air was cooled by a surface condenser supplied with water. With this apparatus about .9 quart of liquid can be obtained per hour with the use of 3 H.P., this being about

TABLE OF PHYSICAL CONSTANTS OF LIQUEFIED GASES.—*Dickerson.*

| Number of Line. | Substance. | Symbol. | Physical Constants. | | | | | | | | | | | |
|-----------------|---------------|-------------------------------|------------------------|-------------|--------------------|-----------------------|---|-------------------------------------|-----------------|-------------|---|----------------------------------|---|-------------------|
| | | | Critical Temperatures. | | Critical Pressure. | | Temp. of Saturated Vapour at Atmos. Pressure. | | Freezing Point. | | Pressure at which Freezing Point was Determined. M.M. | Density of Gas. | Density of Liquid at Temperature Given. | Colour of Liquid. |
| | | | Degs. Cent. | Degs. Fabr. | Atmos. | Degs. Cent. | Degs. Fabr. | Degs. Cent. | Degs. Fabr. | Degs. Cent. | | | | |
| 1 | Water | H ₂ O | 365 | 689 | 200 | 100 | 212 | 0 | 32 | 760 | ... | 1 at 4° C. | Colourless. | |
| 2 | Hyd. Selenide | H ₂ Se | 185 | 365 | 91 | -41 | -41·8 | -68 | -90·4 | ... | 40 | { 0·6364 } { at 0° C. } | " | |
| 3 | Ammonia | NH ₃ | 130 | 266 | 115 | -33 | -27 | -77 | -107 | ... | 8·5 | ... | " | |
| 4 | Propane | C ₃ H ₈ | 97 | 206·6 | 44 | -45 | -49 | { Still liquid } { at -151° C. } | { ... } | ... | 20·95 | ... | " | |
| 5 | Acetylene | C ₂ H ₂ | 37 | 98·6 | ... | -85 | -121 | -81 | -113·8 | 950 | 12·97 | ... | " | |
| 6 | Nitrous Oxide | N ₂ O | 35 | 96 | 75 | -89 | -128 | -115 | -175 | 760 | 21·99 | ... | " | |
| 7 | Ethane | C ₂ H ₆ | 34 | 93·2 | 50·2 | -93 | -135·4 | { Still liquid } { at -151° C. } | { ... } | ... | 19·97 | ... | " | |
| 8 | Carb. Dioxide | CO ₂ | 31 | 88 | 75 | -80 | -112 | -56 | -69 | 760 | 21·94 | 0·83 at 0° C. | " | |
| 9 | Ozone | O ₃ | ... | ... | ... | -93 | -135·4 | ... | ... | ... | 23·89 | ... | Dark blue, easily exploded. | |
| 10 | Ethylene | C ₂ H ₄ | 10 | 50 | 51·7 | -102 | -150 | -169 | -272 | ... | 13·97 | { 0·415 } { at -164° C. } | Colourless. | |
| 11 | Methane | CH ₄ | -81·8 | -115·2 | 54·9 | -164 | -263·4 | -185·8 | -302·4 | 80 | 7·98 | ... | " | |
| 12 | Nitric Oxide | NO | -93·5 | -135 | 71·2 | -153·6 | -254 | -167 | -369 | 138 | 14·98 | { 1·124 at } { -181·4° C. } | " | |
| 13 | Oxygen | O ₂ | -118·8 | -182 | 50·8 | -181·4 | -294·5 | ... | ... | ... | 15·96 | { about 1·5 } { at -187° C. } | Blue. | |
| 14 | Argon | A | -121 | -185·8 | 50·6 | -187 | -304·6 | -189·6 | -309·3 | ... | 19·9 | ... | Colourless. | |
| 15 | Car. Monoxide | CO | -139·5 | -219·1 | 35·5 | -190 | -310 | -207 | -340·6 | 100 | 13·96 | { 0·933 at } { -191·4° C. } | " | |
| 16 | Air | ... | -140 | -220 | 39 | -191·4 | -312·6 | ... | ... | ... | ... | { 0·885 at } { -194·4° C. } | Colourless. | |
| 17 | Nitrogen | N ₂ | -146 | -231 | 35 | -194·4 | -318 | -214 | -353·2 | 60 | 14·01 | ... | " | |
| 18 | Hydrogen | H ₂ | -234 | -389 | 20 | -243 | -405 | ... | ... | ... | 1 | ... | " | |
| 19 | Helium | He | ... | ... | ... | { Below } { -264 } | -443·2 | ... | ... | ... | 2·02 | ... | " | |

5 per cent. of the air handled, the first liquid will appear about two hours after starting up the machine.

The following extended extract from Mr Rice's paper regarding the properties of liquid air will be of interest :—

“The physical constants which have been determined with regard to the liquefied gases are given in the foregoing table, which was prepared by Mr Walter Dickerson. It will be noted that the order of the liquefaction of the gases historically is almost exactly that of the descending critical temperatures. It is the attaining of a low temperature limit that has taken all the time and study that has been devoted to this matter. Some of the gases when in the liquid form are lighter, and some heavier than water, as shown by the values of specific gravity; of the constituents of air, nitrogen is lighter and oxygen is heavier; the mixture, containing four-fifths nitrogen and one-fifth oxygen, is a little lighter than water.

“Professor Jacobus and Mr Dickerson have found the latent heat of air at atmospheric pressure to be about 140 British thermal units, but this figure is stated as only a rough approximation. This is about the only value which has been determined with regard to air in the intermediate or vaporous state.

“Any calculations as to the efficiency of liquid air as a fluid for a prime mover must necessarily be only approximate. The approximations can, however, be made on the right side, and the air given the benefit of the doubt.

“Professor Henry Morton has recently made some calculations regarding the maximum amount of power which could be obtained by the expansion of 1 lb. of liquid air under certain circumstances. The same hypothesis which he used will be assumed and his figures adopted.

“Suppose 1 lb. of liquid air to be confined in a cylinder and heated to 70° Fahr., then let it expand at 70° to atmospheric pressure, the expansion to be hyperbolic. It is not known what the volume of the air will be at 70° before expanding, but it is certain that its ratio of expansion will be less than it would be if expanding from the volume of the liquid at -312° to the volume of the gas at 70° and atmospheric pressure. This ratio is something less than 800, hence we will call the ratio of expansion 800. The volume of 1 lb. of air at 70° Fahr. and atmospheric pressure is 13.36 cub. ft.

“The work done in a hyperbolic expansion is

$$W = p_2 \times v_2 \times \log_e R.$$

When p_2 = final pressure per square foot = 2,117 lbs.

v_2 = final pressure volume = 13.36 cub. ft.

$R = \frac{v_2}{v_1}$ = ratio of expansion.

$W = 2,117 \times 13.36 \times 6.685 = 188,000$ ft.-lbs.

$\frac{188,000}{60 \times 33,000} = .095$ = horse-power per pound of air used per hour,

and $\frac{1}{.095} = 10.55$ lbs. of air per horse-power per hour,

if the terminal pressure equals the back pressure, no compression and no clearance being considered.

“This result cannot, of course, be realised, for there are many sources of loss which cannot be avoided, and which will make this figure for the weight of air per horse-power hour much higher. However, even if it could be realised in actual practice, it is only just inside of the figure which has been obtained in our best steam engines under practical working conditions.

“In these figures the liquid is considered simply as a storage medium for energy, and no account is taken of the amount of heat necessary to develop or store the energy.

“In order to get a comparative idea as to the relative values of liquid air and water for power storage, two similar cycles for water will be calculated, and comparative figures obtained.

“The range of temperature in the cycle taken for air is from -312° to 70° , or 382° .

“Starting with water and heating it to 504° under 700 lbs. pressure absolute, and expanding it to 2 lbs. pressure absolute and 126° Fahr., gives a range of temperature slightly less, viz., 378° . The ratio of expansion will be 254. This final volume of 1 lb. is 172 cub. ft., and considering the expansion to be hyperbolic, we have—

$W = 288 \times 173 \times 5.59 = 280,000$ ft.-lbs.

$\frac{280,000}{60 \times 33,000} = .1415$ H.P. per pound of water used per hour,

and $\frac{1}{.1415} = 7.08$ lbs. of water per horse-power per hour.

“By heating the water to 546° under 1,000 lbs. pressure and expanding to atmospheric pressure the range of temperature would be still less, or about 334° .

“The final volume would be 26.3 cub. ft.

$$\text{Ratio of expansion } \frac{26.3}{.48} = 55.$$

$$W = 21.7 \times 26.3 \times 4.04 = 225,000 \text{ ft.-lbs.}$$

$$\frac{225,000}{60 \times 33,000} = .1139 \text{ H.P. per pound of water used per hour.}$$

$$\frac{1}{.1139} = 8.8 \text{ lbs. water per horse-power per hour.}$$

“From these figures it will be seen that under the conditions assumed water will give off from 20 per cent. to 50 per cent. more energy than liquid air, during expansion through equal temperature ranges. The possibility of the use of liquid air in a prime mover comes from the fact that the upper temperature limit for the range assumed is so low as compared with that for the steam. The upper limit for the air is at 70° Fahr. or 531° absolute, and the possible thermal efficiency is $\frac{382}{531} = .72$; for the water the upper limit is 504° Fahr., or 965° Fahr., and the possible efficiency is $\frac{372}{965} = .39$. If the efficiency of the liquid is in any way comparable with that which can be gotten from steam in the steam engine, the efficiency of the air engine should be good. The cost of production of a pound of air would be much greater than that of a pound of steam, so that to be a commercial factor, the efficiency of the air engine would have to be much greater than that of the steam engine. Whether this can be accomplished the future alone must decide.

“As to other uses, refrigeration, medical cautery, prevention of chemical action, explosive compounds, reduction of resistance of conductors for electricity, and use for prevention of the ill-effects of anæsthetics have been suggested, and others will doubtless develop as experiments are tried. It is only within a few months that the liquid could be obtained at a cost that allowed of trial of its properties for any except scientific purposes where no possible financial return was to be expected, and cost was a secondary consideration. With a large supply available, rapid development may be looked for, and new uses will be constantly discovered.”

APPENDIX

BIBLIOGRAPHY OF REFRIGERATION

Books.

- ANDERSON, J. W. : "Refrigeration : an Elementary Text-book." London, 1908.
- BARNES, H. T. : "Ice Formation." New York.
- BEHREND, GOTTLIEB : "Eis und Kälteerzeugungs Maschinen." Halle-a-Salle, 1888.
- BOYER, DICKERMAN : "Refrigeration." Chicago.
- COOPER, MADISON : "Eggs in Cold Storage." "Practical Cold Storage." Chicago.
- DERMINE, G. : "La Technique du Froid," translated from German of G. Lehnert. Paris, 1911.
- DOUGLAS, LOUDON M. : "Refrigeration in the Dairy." "Douglas' Encyclopædia." London.
- "Encyclopædia Britannica." London, 1911.
- EWING, J. A. : "The Mechanical Production of Cold." 1908.
- GIBBS, VON J. WILLARD : "Thermodynamische Studien." Leipzig.
- GOETTSCHKE, VON GEORGE : "Die Kaltmaschinen." Hamburg.
- GUETH, OSWALD : "The Refrigerating Engineer's Pocket Manual." New York.
- HAUSBRAND, E. : "Evaporating, Condensing, and Cooling Apparatus." London.
- HEINEL, VON C. : "Bau- und Detrieb von Kalte-Maschinenanlagen." München.
- HISCOX, G. D. : "Compressed Air and its Applications." New York.
- KOLLER, THEODORE : "Die Kaelteindustrie."
- LEASK, A. RITCHIE : "Refrigerating Machinery and its Management." Second Edition. London.
- LEDOUX, M. : "Ice-Making Machines," with additions, by Messrs Denton, Jacobus, and Riesenberger. New York.

- LESCARDE, F.: "L'Œuf de Poule sa Conservation par le Froid." Paris.
- LEVY, JOHN: "Refrigerating Memoranda." Chicago.
- LORENZ, HANS: "Neuere Kuehlmaschinen." Muenchen und Leipzig.
- LOVERDO, J. DE: "Le Froid Artificiel et ses Applications Industrielles, Commercial et Agricoles." Paris, 1906. "Abattoirs Publics." Paris, 1906. "Comptes Rendus, Rapports et Communications du Premier Congres International du Froid. Conservation par le Froid des Deurées Alimentaires." Paris, 1908.
- MARCHENA, R. E. DE: "Kompressions Kalte Maschinen."
- MARCHERRA, DE: "Machines Frigorifiques à Gaz Liquifiable." Paris.
- MARCHIS, L.: "Production et Utilisation du Froid." 1906. "Leçons sur Le Froid Industriel." Paris.
- "Monographie sur l'Etat Actuel du Froid en France." Paris, 1911.
- "Nelson's Encyclopædia." Edinburgh.
- PAULDING, C. P.: "Transmission of Heat through Cold Storage Insulation." New York.
- PERRET, AUG.: "Les Machines à Glace et les Applications du Froid dans l'Industrie."
- PETIT, P., AND JACQUET, T.: "Machines Frigorifiques," translated from German of H. Lorenz. Paris, 1910. "Brasserie et Malterie." Paris, 1904.
- "Principles and Practice of Artificial Ice-Making and Refrigeration." *Proceedings, American Warehousemen's Association.* United States.
- Proceedings, Ice and Cold Storage Association.* London.
- Proceedings, Institution Civil Engineers.* London.
- Proceedings, Institution Mechanical Engineers.* London.
- Proceedings, Institute of Marine Engineers.* Stratford, London.
- Proceedings, Shipmasters' Society.* London.
- Proceedings, Société Nationale d'Agriculture de France.*
- PRUDEN, T. M.: "Drinking Water and Ice Supplies." New York.
- REDWOOD, ILTYD J.: "Theoretical and Practical Ammonia Refrigeration." New York.
- RICHMOND, GEORGE: "Notes on the Refrigeration Process and its Place in Thermodynamics." New York.
- RITTER, FRIEDRICH: "Wasser und Eis."
- RUDDICK, J. A., Dairy and Cold Storage Commissioner, Department of Agriculture, Canada: "Reports to the Minister of Agriculture."
- SCHMIDT, L. M.: "Principles and Practice of Artificial Refrigeration." Philadelphia.
- SCHWARZ, ALOIS: "Die Eis und Kuehlmaschinen." Muenchen und Leipzig.

- SCHWARZ, OSCAR: "Public Abattoirs and Cattle Markets." Second Edition, edited by G. T. Harrap, A.M.I.C.E., and L. M. Douglas, A.M.I.M.E.
- SELFE, NORMAN, M.I.C.E.: "Machinery for Refrigeration." Chicago.
- SIEBEL, J. E.: "Compend of Mechanical Refrigeration." Eighth Edition. Chicago.
- SKINKLE, E. T.: "Practical Ice-Making and Refrigeration." Chicago.
- SPON'S "Dictionary of Engineering." London.
- SPON'S "Encyclopædia." London.
- STETEFELD, RICHARD: "Die Eis und Kälteerzeugungs Maschinen." Stuttgart.
- VOORHEES, GARDNER T.: "Indicating the Refrigerating Machine." Chicago.
- WALLIS-TAYLER, A. J., A.M.I.C.E.: "Refrigerating and Ice-Making Machinery." Third Edition. "Refrigeration, Cold Storage, and Ice-Making." Third Edition, 1911. "The Pocket Book of Refrigeration and Ice-Making." Fifth Edition. London, 1911.
- WILLIAMS, HAL., A.M.I.M.E.: "Mechanical Refrigeration." London, 1903.
- WILDER, F. W.: "The Modern Packing House."
- WOOD, DE VOLSON: "Thermodynamics, Heat, Motors, and Refrigerating Machines." New York.

PERIODICAL PUBLICATIONS DEALING WHOLLY OR PARTLY WITH
REFRIGERATION.

- Cold Storage. Monthly. London.
- Cold Storage. Monthly. New York.
- Eis- und Kälte-Industrie. Bi-monthly. Berlin.
- La Revue Générale du Froid.
- "Power," Refrigeration Department. Weekly. New York.
- Proceedings, Ice and Cold Storage Association.
- "Practical Engineer" Pocket Book. Annually. Manchester.
- Ice and Cold Storage. Monthly. London.
- Ice and Cold Storage Trades Directory. Annually. London.
- Ice and Refrigeration. Monthly. New York.
- Ice Record. Monthly. Philadelphia.
- Ice Trade Journal. Monthly. New York.
- Le Froid, La Glace, et La Réfrigération. Monthly. Paris.
- Zeitschrift für Eis. Bi-monthly. Lübeck.
- Zeitschrift für die gesamte Kälte-Industrie. Monthly. Munich.

INDEX

- A**BSOLUTE pressure and temperature, 9
— zero, 9, 10
Absorber for absorption machine, 177, 178, 183, 184, 185, 197
Absorption and binary absorption process, 174-210
— machine, refrigeration by, 274
— in butter works, 462
— system, the, 20, 174-210, 274, 569, 570
Abstraction of heat by compressing air, 211-245
— — by evaporation of liquid to be cooled, 20, 25-33
— — by evaporation and mechanical compression of a separate refrigerating agent, 20, 34-151
— — by evaporation and re-absorption of a separate refrigerating agent, 20
— — by the rapid dissolution of a solid, 20, 21-24
Abyssinian War, use of ether machine, 119
Accumulations of deposit in condenser, 549-551
Admiralty, cold-air machines supplied to, 415, 416
Admixture of sulphurous acid and carbonic acid as a refrigerating agent, 45
Advantages of absorption system, 174, 175
— of atmospheric condensers, 157
— of carbonic acid machines for marine installations, 129, 397
— claimed for Gobert system of constructional congelation, 482
— of cold-air blast system, 279
— of cold-air system, 212
— of Cooper system of mechanical air circulation, 325-328
— of direct expansion system, 275
— of double pipe condensers, 165
— of ether as a refrigerating agent in hot climates, 44
Advantages of submerged condensers, 152
— of using sealing and lubricating oil in ammonia compressors, 56, 57
— of wall or plate system of ice-making, 496
— of Yaryan apparatus for the production of distilled water, 512-517
After preservation of frozen meet, 272
Agent, liquefied arrangement for removal of, from condenser, 159, 160
— or medium used in vacuum machines, 32, 33
Agitation, method of making clear crystal ice by, 485, 487-507
Air agitation system of making clear or crystal ice, 502
— atmospheric, germs of fungus or mould in, 313
— aqueous vapour held in suspension in, 573
— circulation, means for improving, 315-319
— — of, in cold storage chambers, 313-328, 431, 432
— cold, machines, 20, 211-245, 272-274
— cooler, or chamber, with corrugated brine battery, 292-295
— degree of, saturation of, 572
— determination of moisture in, 570-573
— effect of presence of, 541
— ejection of, from ammonia system, 539-540
— instruments for measuring moisture in, 570, 571
— presence of, in ammonia machine, to detect, 541
— pressure, testing ammonia compressor under, 539, 540
— trunks, construction of, 271
— value of, as in insulator, 330
Allen dense-air ice machine, 238-241
Allowances, per ton capacity, in refrigerating machine, 286, 287, 457
America, number of firms directly interested in refrigeration in, 7

- American absorption machine, 205-209
 — arrangement for removing liquefied agent from condenser, 159, 160
 — — for wort cooling, 446, 447
 — *Engineer*, relative heat conductivity of various materials, 336
 — ice-making machines, 22
 — practice as to the making of brine, 532-534
 — Society of Mechanical Engineers, paper on regenerative method of producing very low temperatures, 593
 — Warehousemen's Association, table showing transmission of heat through various insulating structures, 345-350
- Ammonia, advantages of, as a refrigerating agent, 48
 — anhydrous, 49
 — — boiling point and latent heat of, 48
 — — manufacture of, 49, 50
 — anti-putrescent qualities of, 276
 — apparatus, leaks in, 559
 — composition of, 48
 — compression machines, arrangement of, in butter dairies, 425-429
 — — management of, 539-578
 — — marine types, 402-413
 — condensers, marine types, 401, 409
 — disadvantages of, as a refrigerating agent, 48-50
 — gas, difficulties of dealing with, 50
 — — superheating of, 542
 — lubricating qualities of, 552
 — machines, 48-116
 — machine, most important part of, 50-56
 — of commerce, 49, 50
 — properties of, 48
 — receiver and oil trap, 549
- Amount of condenser surface required, 155, 157, 164
 — of cooling water required, 156, 157, 164
 — of refrigerating pipes necessary for chilling, storage, and freezing chambers, 280, 281
 — of refrigeration required in cold stores, 280
 — of water required in refrigerating apparatus, 570
- Analyser for absorption machine, 182
- Ancients, production of ice known to, 1
 — use of liquefaction by, for refrigerating purposes, 21
- Andreef formula of relation of specific gravity of sulphurous acid to temperature, 121
- Andrews' experiments in liquefaction of gases, 588
- Angle valve, 247
- Anhydride, carbonic. *See* Carbonic acid
- Anhydrous ammonia, 49
 — — boiling point and latent heat of, 48
 — — manufacture of, 49, 50
 — sulphurous acid and carbonic acid refrigerating agent, 45
- Antarctic, single-acting compressor, 108
- Anti-putrescent properties of ammonia, 276
- Apparatus, ammonia, leaks in, 559
 — for de-aerating or distilling water, 508-517
 — for making distilled water from exhaust steam, 510
 — gravity, for lowering carcases, 380
- Appendix, 602-604
- Apples, cold storage of, 389
 — first cargo of, from Melbourne, 6
- Appliances required in absorption system, 174, 175
- Applications of refrigeration, constructional, 473-483
 — — manufacturing, 439-473
- Approximate allowances, per ton capacity, in refrigerating machine, 286, 287, 457
 — cost of operating ice factories, 586
 — — of ice-making, 587
- Aqueous vapour held in suspension in pure dry air, 573
- Architectural aspects of cold stores, 285
- Arctic cold-air machines, 211, 212, 234-238
 — — — experiments with, 244
- Machine Manufacturing Co., ammonia compressors, 104
- Areas. *See* Diameters, areas, and displacements
- Armitage, Mr H. T., regulating the fermentation of tea by refrigeration, 464
- Armstrong, Lord, definition of heat by, 9
- Arrangement for chilling and freezing on wall system, 292-294
 — for cooling fermenting rooms, 446-451
 — for increasing surface of cooling pipes, 268, 269, 292
 — for lifting ice cans, 523-529
 — for more even distribution of work of compressor piston, 105
 — for traversing carcases through chilling and freezing rooms, 293
 — of air-cooling tower, 295-297

- Arrangement of cold stores, internal, 285
 — of cooling pipes in bacon factories, 305, 306
 — — — in ceiling lofts, 290¹
 — — — in cold stores, 280-284
 — — — on brine circulation system, 274, 275
 — of corrugated brine air-cooling battery, 294-295
 — of piping in cold storage rooms, 280-284, 313-328
 — of refrigerating plant in an hotel, 309-312
 Arrangements for making clear or crystal ice, miscellaneous, 499-508
 — of pump or piston agitators, 505-507
 Articles, various proper temperatures for cold storage of, 381-395
 Artificial butter factories, use of refrigerating machinery in, 461-464
 — cold, use of, by Esthonian tribe, 21
 — currents of air, atmospheric condensers cooled by, 161
 — ice, storage house for, 535
 — refrigeration in bacon curing works, 305, 306
 — — origin of, 1
 — surfaces of ice, formation of, 473
 Asbestos paper or cloth, value of, as an insulating material, 335
 — results of tests as to conductivities of, 334
 — use of, as an insulating material, 329
 Ashantee campaigns, use of ether machine, 120
 Asparagus, cold storage of, 391, 392
 Atlas Company, Ltd., carbonic acid compressor, 149-151
 Atmosphere of cold stores, 271, 272, 273, 277
 — of hospitals and large public buildings, cooling of, 472
 Atmospheric surface condensers, 157-164.
See also Condensers
 Attenuating in breweries, refrigerated water for, 444, 451-455
 Auldjo Machine Co., compressor made by, 108
 Australian apples, trade in, 6
 Australia, use of pumice stone as an insulating material in, 329
 Automatic electric beef hoist, 372-376
 — ice dump, 525-527
 — Refrigerating Machine Co., ammonia compressor, 100
 Auxiliary or separate absorber, 194
 Aylesbury Dairy, vacuum machine at, 27
- BABY compressor, A. H. Barber Manufacturing Co., 111, 112
 Back pressure, loss of efficiency in ammonia compressors from, 56
 Bacon factories, arrangement of cooling pipes in, 305, 306
 — — reasons for use of artificial refrigeration in, 306
 Bait, freezing, 472
 Ball, improvements in absorption machines, 197, 198
 Balloons, use of refrigeration for purification of gas for inflation of, 472
 Baltic, imports of butter from, 6
 Bananas, transport of, from Jamaica, 3
 Barber, A. H., Manufacturing Co., double-acting ammonia compressor, 108-111
 — — — plans for insulation, 365
 — — — small cold store and ice plant for hotel, 309, 310
 — — — single-acting ammonia compressor, 111, 112
 Bar-box, cooling of, 209
 Barges, refrigerated, 421
 Barnard water-cooling tower, 170
 Barrel, old, to make brine mixer of, 533
 Baudelot cooler for breweries, 446, 447
 Bavarian engineers, tests of Linde compression machine by committee of, 80, 81
 Bayswater, vacuum machine at, 27
 Beck, William Henry, improvements in absorption machines, 175, 184
 Becks, G. A., experiments on heat conductivity of slag wool and charcoal, 342, 343
 Beef chill-room fitted with Haslam patent brine-cooling battery, 301-303
 — — fitted with the De La Vergne patent pipe system, 298-301
 — hoist, automatic, electrically operated, 372-376
 Beer wort, refrigeration of, 444-446
 Beffa, Della, & West, ether machine, 42
 Belgian dairies, type of cream cooler used in, 431
 Bell-Coleman cold-air machine, 221, 222, 243, 244
 — freezing machine, tests to determine best covering for, 336
 Berryman system of making ice, 502-504
 Bibliography of refrigeration, 602-604
 Binary absorption process, 209, 210
 Black currants, cold storage of, 389
 Black, Dr, discovery of latent heat by, 10
 Blast, cold-air system

- Blast furnaces, use of refrigeration in, 465-469
- Bleaching of clothes by refrigeration, 472
- Block, Louis, improvements in ammonia compressors, 57, 58
- Blowers, use of, for cooling atmospheric condensers, 161
- Blythe & Southby, improved vacuum machine, 31, 32
- Board of Trade instructions to surveyors *re* carbonic acid machines, 397
- Boiler-covering materials, heat conductivity of, 340
- feeding purposes, use of waste condensation water for, 168
- Boiling point, latent heat, &c., of anhydrous ammonia, 48
- Books on refrigeration, 602-604
- Borsig, A., sulphurous acid machines, 129
- Bottles containing anhydrous ammonia, warming when charging machine from, 540
- — — — desirability of keeping in cool place, 541
- Box & Lightfoot, table of aqueous vapour held in suspension in air, 573
- Box radiation through walls, 288
- Boyle, Mr David, pioneer of refrigerating machinery, 97
- — — modern type of ammonia compressor, 97
- Boyle's or Marriotte's law, 18
- Bramwell, Sir Frederick, on Perkin's compression machine, 34
- Breaking joints in ammonia machines, 551, 552
- machinery, ice, 537, 538
- Breweries, cubic feet of space per running foot of 2-in. piping, 281
- refrigeration in, 444-458
- rough estimate of refrigeration in, 457
- Brewery, ammonia pumps or compressor for, 86, 87
- Brick surfaces, waterproof coatings for, 345-350
- Bridge, Messrs David, & Co., ice crushing or breaking machinery, 537, 538
- Brine, forming of, 492
- circulation system, arrangement of cooling pipes on, 274, 275, 313-328
- — — of refrigeration, 274-275
- — — objections to, 279
- — — in breweries, 446, 447, 448
- cold, passing air through body of, 297
- concentrator, 534
- cooling battery for cooling air, 295-297
- Brine for use in refrigerating and ice-making plants, 532-534
- mixing tank, 532, 533
- strainer, 533
- British Government, use of refrigerating machines by, 119, 120
- Humboldt. *See* Humboldt
- Broadbent, Mr J. C., rotary chocolate cooler, 443, 444
- Brompton, vacuum machine at, 27
- Bronze alloy, use of, in compressor cylinder, 143
- Brotherhood's refrigerator, 445
- Buffalo Refrigerating Machine Co., ammonia compressor, 102-104
- "Bulletin de la Société de l'Industrie Minerale," Poetsch process, 422-438
- Bureau, U.S. Weather, saturation of air, 572
- Burnand ice refrigerating machine, 436, 437
- Butter, artificial use of refrigeration in factories of, 461-464
- brought over from Denmark, 6
- imports of, 6
- manufactories and dairies, refrigeration in, 422-438
- preservation of, by refrigeration, 385
- C**ABBAGE, cold storage of, 391, 392
- Cailletet, experiments in liquefaction of gases, 588
- Calahan suction valve, 260
- Calculations made with respect to heat, 11-19
- "Campania," refrigeration of cargo holds on board of, 409-411
- — of provision store on board of, 411-413
- Campbell. *See* Westerlin and Campbell
- Canada, imports of butter and cheese from, 6
- Canadian apples, trade in, 6
- Canadian Farming World*, article on filling ice houses, 535
- Candle and paraffin oil works, refrigeration in, 459-461
- Can hoist for small plants, 525
- system of ice-making, 487-492
- — — objectionable features of, 488-490
- Cans or moulds, ice, 27
- Canvas saturated with cold brine, cooling air with, 297
- Capacities, refrigerating, table of, 284
- Capacity of machine required for refrigeration of cold chamber, 286, 287

- Capacity of refrigerating machine, diagram showing variations in, 277
- Capillary cream cooler, 431
- Carafes, arrangement for freezing, 309
- frappés, production of, 27
- Carbon dioxide. *See* Carbonic acid
- Carbonic acid, advantages of, 47
- — and sulphurous acid refrigerating agent, 45
- — composition of, 129
- — compressors, 45, 46
- — disadvantages of, 47
- — machine, 45-47
- — — consumption of water in, 142
- — — leaks in, 560
- — — marine types, 396-401
- — — to charge and work, 554-556
- — properties of, 45-47
- — solidification of gas, 129, 130
- anhydride. *See* Carbonic acid
- Carcasses, freezing of, for transport, 270-272
- imports of frozen, 2-4
- packing, in cold rooms, 271, 286
- storing, on board ship, 417, 418
- Carcass hoists, 372-380
- Cards. *See* Diagrams
- Cargo of apples, first, from Melbourne, 3
- of frozen meat, first, 2
- of fruit, storage of, 419
- Carpets, preservation of, by refrigeration, 472
- Carré, Edmond, sulphuric acid machines, 27
- Ferdinand, absorption machine, 174, 175-179
- hand power ice machine, 33
- Carrots, cold storage of, 391, 392
- Cars, refrigerated. *See* Vans
- Cascade system of producing very low temperatures, 588-592
- Case Refrigerating Machine Co.'s ammonia compression machines, 108
- Catamba grapes, cold storage of, 388
- Cattle, live, cooling holds of vessels for, 473
- Ceiling lofts, cooling pipes in, 290-292
- Ceilings for cold stores and ice houses, 356, 357
- Celery, cold storage of, 391, 392
- Cell ice-making boxes or tanks, 496-499
- Centigrade thermometrical scale, zero on, 12
- Challoner, Sons, & Co., Geo., ammonia compressor, 104, 105
- Chambers. *See* Cold storage chambers
- Charcoal, consistency for packing insulating spaces with, 330
- Charge and work carbonic acid machine, to, 554-556
- Charging an ammonia machine, 540, 541
- Charles' law of expansion of gases, 12, 13
- Chart applicable to any value of n , construction of, 14-16
- Chatwood electrical thermometer, 575, 576
- Cheese, imports of, from Canada, 16
- refrigeration of, 386
- Chemical process of refrigeration, the, 20, 21-24
- works, use of refrigeration in, 472
- Cherries, cold storage of, 389
- Chew, Mr Leuig, submerged condenser, 154
- Chief danger of deterioration of frozen meat, 6
- features to be looked for in an air-cooling tower, 157, 158
- Childs, J. G., & Co., Ltd., automatic electric beef hoist, 372-376
- — — mutton hoist, 376
- Chilled beef, imports of, 3
- Chilling, amount of refrigerating pipes necessary for, 280
- or freezing on wall system, 292, 293
- Chill-room, bacon, with side and ceiling cooling pipes, 303-306
- beef, cooled by brine air-cooling battery, 301-303
- — fitted with patent pipe system, 298-303
- Chimogene, use of, as a refrigerating agent, 44
- Chloride, methyl, properties of, 120
- of sodium, brine made from, 274
- Chocolate, cold slabs or tables for manufacture of, 193, 194
- cooler, rotary, 443, 444
- cooling by cold air, 442, 443
- — Enock & Co., Ltd., 440-442
- — first application of refrigerating machine to, 440
- manufacture, use of refrigeration in, 440-444
- Choice of agent for refrigerating purposes, 35-37
- Choking up or freezing of compression system, 557, 558
- Christiansen, Adolph Gothard, improvements in absorption machines, 175, 184, 185
- *See also* Mackay and Christiansen
- Circulation, methods of piping that hinder air, 313-316
- of air in cold storage chambers, 313-328
- Citron. *See* Citrus fruits

- Citrus fruits, cold storage of, 388
- Clark, Mr D. K., report on experiments with non-conducting substances, 336
- Classification of refrigerating machinery, 20
- Clausius, definition of heat by, 9
- Clearances in ammonia compressors, 53-56
- Clear or crystal ice, arrangements for making, 485-508
- Cleveland, Ohio, Twining's compression machine in, 37, 38
- Clothes, white bleaching of, by refrigeration, 472
- Cloth, hard-pressed asbestos, value of, as an insulating material, 335
- Clouet, experiments by, in liquefaction of gases, 588
- Coal ashes, use of, for insulating purposes, 329
- consumption of, by cold-air machines, 273, 274
- Coating of ice on direct expansion pipes, 560
- Coatings for brick surfaces, waterproof, 345-350
- Cochran Co., carbonic acid compressor, 149
- Cocks and valves, 246-269
- expansion or regulating, 53, 246-252
- stop, 252-256
- suction and discharge, 256-260
- Coil bend, evaporating, 265-267
- Coils defrosting of refrigerating, 560, 561
- of pipe in submerged condenser, dimensions of, 155-157
- Coke, use of, for charging air-cooling tower, 296
- Cold air blast system, the, 279-280
- machines, 20, 211-245, 272-274
- — — advantages of, 212
- — — for marine work, 414-417
- — — marine types, 396-421
- — — modern patterns of, 416
- — — proper management of, 562
- — — pumps of, 211
- — — refrigeration, by, 270-274
- — system, the, 211-245
- — trunk for marine installations, 416, 417
- brine, passing air through body of, 297
- rooms or chambers, construction of, 285-364
- — — packing of carcasses in, 286
- simple method of producing, in hot climates, 25
- Cold slabs or tables for the manufacture of chocolate, 193, 194
- storage chambers, circulation of air in, 313-328, 417
- — — temperatures for, 392-395
- — — ventilation of, 312, 313
- — cubic feet of space per running foot of 2-in. piping, 281
- — space, inspection of, 417
- — 270-328
- stores, ceilings for, 356, 357
- — divisional partitions for, 353, 354, 355, 356
- — flooring for, 355, 356
- — lighting of, 576-578
- — in United Kingdom, 7
- — piping for, 280-284
- — ventilating shafts for, 312
- — walls for, 350-354
- various manufacturing, &c., applications, 439-483
- Coleman, C. J., improved absorption machine, 203-205
- J. J., experiments by, on heat conductivities of substances, 335, 336
- See Bell-Coleman
- Cole, Messrs T. & W., Ltd., chocolate cooling, 442, 443
- — — cold-air machine, 211, 212, 244
- — — marine, 417
- Collectors or oil separators, 76, 509, 510, 544-549
- “Colliery Manager's Handbook,” Gobert congelation method, 477-483
- shafts, application of refrigeration to sinking of, 472, 474-483
- Collins, Mr W. Hepworth, on evaporative values of various substances, 336
- Colyer, Frederick, C.E., results obtained with ether machine, 43, 44
- — — on working of absorption machine, 579, 580
- Combined refrigerating and ice-making tank, 507
- utilisation of cold air and brine for cooling, 292
- Common ammonia of commerce, 49, 50
- salt. See Chloride of sodium
- Compensating chamber for stuffing box, 85
- Complete discharge of gas from compressor cylinder, to ensure, 53, 54
- installation of ammonia plant on the De La Vergne system, 59-62
- small brewery fitted with refrigerating plant, 458
- Composition of freezing mixtures, 24

- Composition of fossil meal, use of, for insulating purposes, 329, 330
 — — kieselguhr, use of, for insulating purposes, 329, 334, 335
 — — victuals, 383
 Compound ammonia compressors, 93-99, 398, 407
 — — compressor, Haslam marine type, 406, 407
 — — — Linde marine type, 403
 — — — single-acting marine type, 402
 — submerged condensers, 154, 155
 Compression head, safety, 69, 70
 — heat generated by, misleading phrase, 16, 17
 — machine, refrigeration by means of, 274
 — machines, ammonia, cycle of operation in, 52
 — — main parts comprised in all, 20, 34-36, 37
 — process, the, 18, 20, 34-151. *See also* Compression system
 — side of ammonia machines, 52
 — system, choking up or freezing of, 557, 558
 — — the, 20
 Compressor, connection of oil separator to, so that oil can be used over again, 549
 — diagrams, interpretation of, 566-569
 — piston rod packings, 552-554
 — safety crosshead for, 71, 72
 Compressors, ammonia, 51-116, 402-413
 — carbonic acid, 45, 46
 — double-acting, 51
 — ether, 34-44
 — methyl chloride, 120
 — methylic ether, 40
 — safety spring heads for, 66-74
 — single-acting, advantages of, 51
 — — disadvantages of, 51
 — sulphurous acid, 120-129
 Condensation side of ammonia machines, 52
 Condensed ammonia, to prevent loss of efficiency by heating of, 543, 544
 — water cooler and oil separator, 509
 Condenser, accumulations of deposit in, 549-551
 — atmospheric, condensing surface required, 155-157
 — cooling water required, 142, 156, 157
 — — — for, 168-173, 543
 — distribution of cooling water, 157, 158
 — Hall, 134
 — incrustation, 560, 561
 — marine type, 408-409
 Condenser preventing spluttering of cooling water, 158, 159
 — removing liquefied agent from, 159, 160
 — usual dimensions of, 164
 Condensers, ammonia, marine type, 401, 409-411
 — 87, 120, 127, 128, 132, 133, 134, 135, 138, 146, 149, 151, 152-168, 401, 409-411
 Condensing pressure, use of, for ascertaining whether apparatus is fully charged, 564, 565
 — surface for atmospheric condensers, amount required, 164
 — — for submerged condensers, amount required, 155-157
 Conductivity of various substances, experiments on, 330-345
 Confectionery, cold slabs or tables for the manufacture of, 193, 194
 Congealing tanks, marine, 418
 Connections. *See* Flange unions
 Conroy. *See* Douglas and Conroy
 Consistency for packing insulating spaces, 330
 Constructional applications of refrigeration, 439, 440, 473-483
 Construction of ammonia gas compressors, 51-56
 — and arrangement of cold stores, 285
 Consumption of water in sulphuric acid machines, 28, 29
 — *See also* Coal consumption
 Continent, number of firms directly interested in refrigeration on, 7
 Continuous-acting absorption machine, 175
 Conveying machinery, ice, 520-529
 — — *See also* Hoisting and conveying machinery
 Coolers for cold-air machines, 220, 222
 — Baudelot, 446, 447
 Cooling air, arrangements for, 292-328
 — battery, corrugated brine, 292-294
 — fermenting rooms, 446-451
 — pipes, arrangement of, in ceiling lofts, 303, 318, 319
 — — — on brine circulation system, 274, 275, 289, 290
 — surface of pipes, means for increasing, 268, 269, 292
 — towers, water, 168-173
 — water, formula for calculating amount required in submerged condensers, 156
 — — for condenser, 168-173, 543
 — — in separator jacket, 542
 — — to economise, 168

- Cooper, Madison, arrangement for washing, cooling, and drying air, 297, 298
- — correct relative humidity for a given temperature in egg rooms, 387, 388
 - — on air circulation in cold storage chambers, 313-328
 - — on cold storage of eggs, 297, 298, 387, 388
 - system of mechanical air circulation, advantages of, 328
- Corliss engine for driving ammonia compressor, 81, 110, 114
- Correct relative humidity for a given temperature in egg rooms, 387, 388
- Corrosion of cooling pipes, protection of, from, 276, 277
- Cost of ice-making, approximate, 587
- of operating ice factories, approximate, 586
 - of working refrigerating machinery, 579-587
- Cotton wool. *See* Slag wool
- Coupon system of selling and delivering ice, 536, 537
- Courrières, use of refrigeration for shaft sinking at, 475
- Cracknell's patent absorption machine, 198-200
- Crane with long jib for raising carcasses from barges into cold stores, 378
- Cream coolers, 430, 431
- trade in frozen, 6
- Creamery Package Manufacturing Co., ammonia compressor, 105, 106
- refrigerators, 431-436
- Creams, freezing, ice, 309
- Crescent or semi-cylindrical door for cold storage rooms, 310-312
- Crosshead, safety, for compressors, 71, 72
- Crushing or breaking machinery, ice, 537, 538
- Crystal ice. *See* Clear ice
- Cube ice, 530
- Cubic feet of ammonia gas per minute to produce one ton of refrigeration per day, 278
- — of space per running foot of 2-in. piping, 281
 - ice, 530
- Cullen, Dr, experiments with ether, 34
- — vacuum machine, 26
- Currants, cold storage of, 389, 393
- Curve $PV^n = \text{constant}$, to construct, 14, 15
- Cycle of operations in compression machines, 35-37
- Cylinder system creamery refrigerator 433
- Cylindrical oil separators or collectors, 545-548
- Cyrogene, use of, as a refrigerating agent, 44
- D**AIRIES, refrigeration in, 422-438
- Davy, Sir Humphry, definition of heat by, 8
- Dead bodies, preservation of, by refrigeration, 391
- weight safety valve, 144
- De-aerated water, making clear ice with, 485
- De-aerating or distilling apparatus, 508-517
- Definition of latent heat, 10
- of specific heat, 10
- Definitions of heat, various, 8-10
- Defrosting of refrigerating coils, 560, 561
- Dehydrator. *See* Drier
- De La Vergne arrangement for cooling in brewery, 448-450
- atmospheric condenser, 153
 - disc or gill for cooling pipes, 268, 269
 - expansion cock, 247, 148
 - installation at skating rink, 473
 - installations on "Campania" and "Lucania," 411-413
 - marine types of ammonia machines, 402
 - oil separator or collector, 76, 544, 545
 - patent pipe system, 268, 269, 298-301
 - safety suction valve, 260
 - stop-cock, 252, 253
 - type of ammonia compressor, 56-66
 - — of pipe joint, 261, 262, 265
- Delion and Lepen, sulphurous acid machine, 129
- Della Beffa and West ether machine, 42
- De Mairan, specific gravity of ice, 484
- De Motay and Rossi absorption machine, 210
- Denmark, butter brought over from, 6
- Dense air machine, 228-241
- Denton, Professor, losses in compressors, 91
- Deposit in condenser, accumulations of, 549-551
- Deterioration of frozen meat, chief dangers of, 6
- Determination of moisture in air, 570-573
- Dewar, Professor, production of liquid air, 590, 591, 592

- Dewar, Professor, use of ethylene as an agent, 590
 — — vacuum flask, 591
 Diagrams from "Arctic" cold-air machine, 237, 238
 — — Frick compressors, 70, 71
 — — interpretation of compressor, 566-569
 Diagram showing variations in capacity of refrigerating machine, 277
 — — taken from double-acting compressor, with sealing oil, 64, 66
 — — — single-acting compressor, without sealing oil, 63, 64
 — — — single-acting compressor, with sealing oil, 64, 66
 Diameter and stroke, ratio between, in ammonia compressors, 54-56
 Dickerson, Mr Walter, on physical constants of liquefied gases, 599-601
 Dimensions of submerged condensers, 155-157
 Direct expansion, cooling brewery fermenting room by, 448
 — — making ice by, 486
 — — pipes, effect of a coating of ice on, 560
 — — system, 275-279
 Disadvantages of cold-air system, 211
 — — cold-air blast system, 279
 Discharge of gas from compressor, to effect complete, 53, 54
 — valves. *See* Suction and discharge valves
 Discs or gills for cooling pipes, 268, 269
 — rotating, cooling air with, 297
 Dissolution of a solid, abstraction of heat by, 20
 Distillation of anhydrous ammonia, 49, 50
 Distilling. *See* De-aerating
 — machine, methylic ether, 40
 Distinctive feature of the Yaryan evaporator, 513
 Distinct meanings of heat and temperature, 10
 Distributing valve. *See* Expansion valve
 Distribution of water in atmospheric condenser, 158, 159
 — of work of compressor piston, 105
 Divisional partitions for cold stores, 353, 354
 Dobbie, John G., tests by, to determine conductivity of asbestos and Kieselghur composition, 334, 335
 Donaldson, H. F., lifts designed by, 378-380
 — non-conductive values of different materials, 337, 338
 Door insulation, 357-360
 Door, rotary, 310-312
 — wedge, 357
 Dortch. *See* Suppes and Dortch
 Douane, Messrs, methyl chloride compression machines, 120
 Douane, Mr M. E. *See* Douane, Messrs
 Double-acting compressor and tandem compound condensing steam engine, 90
 — — compressors, advantages of, 51
 — — — disadvantages of, 51
 — — compressor stuffing boxes, packing for, 553
 — — De La Vergne ammonia compressor, 56-66
 — — Kilbourn horizontal ammonia compression machine, 408
 — effect water-distilling apparatus, 516
 — pipe condensers, 165
 Douglas and Conroy patent sulphurous acid compressor, 124-128
 Douglas, Messrs Wm., & Sons, Ltd., air-cooling apparatus, 295-297
 — — sulphurous acid compressor, 124-128
 — Mr Loudon, on dairy refrigeration, 422
 — Mr T., apparatus for cooling air, 295-297
 Dourges, use of refrigeration for sinking shafts at, 475
 Drawbacks to wall or plate system of ice-making, 495
 Drier or dehydrator of ammonia still, lime in, 50
 Drip trays for cooling pipes, 298, 305
 Drop valve steam engine for driving compressor, 94
 Dry air refrigerator, 242
 — system of working ammonia compression machines, 52, 53
 Drying, cooling, and washing air, apparatus for, 297, 298
 Dual absorption system, 209, 210
 Duplex marine type of carbonic acid machines, 398-401
 Duterne, Victor, metallic packing, 478
 Dynamics, thermo, first lesson of, 8-19
 Dynamite factories, refrigeration in, 471
 EARLY investigators and experimenters in the production of very low temperatures, 588-592
 Eclipse atmospheric condenser, 158
 — can ice-making box, 488
 — — system, plan of ice factory on, 520, 526

- Economiser or temperature exchanger, 181, 197
- Economy of direct expansion system, 275
- of multiple effect distilling apparatus, 512
- Effective surface of cooling pipes, to increase, 268, 269
- effect of a coating of ice on direct expansion pipes, 560
- Efficiencies of ice plants, 531
- Efficiency, loss of, in ammonia compressors, 56
- of refrigerating machines, greatest theoretical, 17
- of submerged condenser, to ensure utmost, 154
- principal qualities to be sought for in compressor to ensure maximum, 53-56
- water-cooling apparatus, 170
- Egg rooms, correct relative humidity in, 387, 388
- Eggs, cold storage of, 297, 298, 386-388
- Egypt, use of ether machine during military operations in, 120
- Elder, Dempster, & Co., transport of bananas from Jamaica by, 3
- Electrically driven ammonia compressor, 110, 111, 413
- — compressor on railway van, 371
- operated beef hoist, 372-376
- — — mutton hoist, 377
- — thermometer or telethermometer, 575, 576
- heated absorption machine, 203-205
- Electrical temperature tell-tales and long-distance thermometers, 573, 574
- welding of condenser and evaporator coils, 135
- Electric fans, use of, for circulating air, 319, 320
- welding, 135
- Elevating and conveying machinery, ice, 520-529
- Elevators or hoists, ice, 527-529
- Emery, Charles E., experiments with non-conductors of heat, 335
- Enclosed compressors. *See* Inclosed
- Endless travelling band or apron chocolate-cooling apparatus, 444
- Engineer, description of Poetsch method in, 475
- Engineering, non-heat-conducting properties of various substances, 341
- Engine-room of steamships, location of carbonic acid machines in, 397
- Enock, Arthur G., safety device for compressors, 71, 72
- Enock compressors, 71-79
- — marine type, 413
- milk-cooling plant, 423-425
- on proper temperature for storing butter, 438
- Equation expressing greatest theoretical efficiency of a refrigerating machine, 17
- Equivalent of a ton of ice, 484
- of heat, mechanical, 11, 18
- Escher, Wyss, et Cie, carbonic acid machine, 151
- Esthonian tribe, use of artificial cold by, 21
- Estimate of refrigeration required in breweries, 437
- Ether, advantages of, as an agent in hot climates, 44
- composition of, 117
- compression machines, 34-44, 117-120
- experiments with, by Dr Cullen, 34
- machine at brewery, first, 439
- — cost of working, 582, 583
- methylic, distilling machine, 40
- objections to the use of, as a refrigerating agent, 44
- properties of, 117
- Evaporating coil bend, 265-267
- Evaporative surface condensers, 157-164
- Evaporator, care of, 517
- Evaporators, 87, 91, 135, 155
- Even distribution of work of compressor, arrangement for, 105
- Ewing, Professor, on cascade or successive cycle system, 589, 590
- on regenerative method, 592
- Exchanger, heat. *See* Economiser
- Exhaust steam, apparatus for making distilled water from, 510
- Exhibition, Paris, carbonic acid compressor in brewery section, 151
- Expansion, direct, economy of, 275
- of gases, laws of, 12
- side of ammonia compression machines, 52
- system, the, 275-279
- valve for methylic ether machine, 42
- valves and cocks, adjustment of, 53
- — — various, 246-252
- Experiments by Dr Cullen with ether, 34
- on the transmission of heat, 344, 345
- with cold-air machines, 244
- with non-conducting substances, 330-345
- Express Dairy, milk-cooling installation at, 425-428
- External carcass hoist, 376-378
- Extreme limits of space per foot of piping, 281

- F**ACTORIES, artificial butter, 461-464
 — bacon, 305, 306
 — ice, 518-529
 — sugar, 464, 465
 — tea, 464
 Fahrenheit, thermometrical scale, zero on, 12
 Fans or blowers for cooling atmospheric condensers, 161
 — use of, for circulating air in cold stores, 319-328
 Faraday, Professor, experiments in liquefaction of gases, 588
 Feathering agitators, 488
 Features, chief, to be looked for in water-cooling tower, 170
 Fermenting rooms, cooling of, 446-450, 464
 Film evaporation, 513
 Firms directly interested in refrigeration, number of, 7
 First cargo of apples from Melbourne, 6
 — class ether machine, results obtained with, 43
 — compression machine, 34
 — law of thermo-dynamics, 8
 Fish, cold storage of, 383-385
 — freezing, cubic feet of space per running foot of 2-in. piping, 281
 Fixary ammonia compressor, 83, 84
 — air coolers, 303
 Flange unions or connections, 264, 265
 Flash valve. *See* Expansion valve
 Flasks of CO₂, warming when charging machine from, 554
 Flasks, vacuum, for liquid air, 591
 Flat plates for air-cooling batteries, 292, 293
 Flines les Raches, use of refrigeration for sinking shafts at, 475
 Flooring for cold stores, 355, 356
 — — ice houses, 356
 Floors of cold stores, radiation of heat through, 288
 Fluorine, liquefaction of, 592
 Fontaine. *See* Mollet, Fontaine, et Cie
 Fontinette canal lift, use of refrigeration in construction of, 476
 Forbidden fruit, cold storage of, 388
 Forced air circulation, 319-328
 Forecoolers. *See* Supplementary condensers
 Formula for ascertaining amount of air delivered by cold-air machine, 245
 — — calculating amount of cooling water for submerged condensers, 156, 157
 — — — dimensions of submerged condensers, 155, 156
 Foundations, application of refrigeration to the construction of, 473
 France, simple method of making ice, used in, 25
 — use of cork in, as a non-conductor, 329
 Freezing chambers, amount of refrigerating pipes necessary for, 280
 — fish, method of, 383, 384
 — mixtures, table of, 24
 — or choking up of compression system, 557, 558
 — times for different temperatures and thicknesses of can ice, 491
 — water slowly, at comparatively high temperatures, 485
 French absorption machine, 193, 209
 — brewery section of Paris Exhibition, carbonic acid compressor at, 151
 Fresh provisions, trade in, 1-7
 Frick ammonia compression machine, 66-71
 — Co., apparatus for making distilled water, 510
 — — arrangement for cooling brewery fermenting rooms, 451
 — — Baudelot cooling apparatus, 446, 447
 — — brine strainer, 491
 — — can ice-making box, 488
 — — cost of operating ice factories, 586
 — — ice-can hoist, 525
 — — pattern of suction valve, 260
 — — plans for ice factories, 520
 — — plans for insulation, 365
 — — stop-valves, 254
 — — truck in can hoist, 525
 — — pipe joints, 265-268
 Frigorific mixtures, general law governing production of cold by, 23
 — — observations on, 23
 — — *See also* Freezing mixtures
 Frozen beef, imports of, from New South Wales, 3
 — — imports of, from New Zealand, 3
 — carcasses, imports of, 2-4
 — cream, trade in, 6
 — meat, trade in, 2
 — mutton, hanging of, before cooking, 286
 Fruit cargo, proper stowage of, 418, 419
 — trees, regulation of, by refrigeration, 472
 Fruits, cold storage of, 388-390, 410, 419
 Fry, J. S., use of cold air for chocolate-cooling by, 440
 Function of refrigerating and ice-making apparatus, main, 19

Fungus or mould, germs of, in atmospheric air, 313
 Furnaces, blast, use of refrigeration in, 465-469
 Furniture, upholstered, preservation of, by refrigeration, 472
 Furs, preservation of, by refrigeration, 391, 472, 473

GALE, ARTHUR ROBERT, paper on refrigerating machine, 241-243
 Gas, ammonia, difficulties of dealing with, 50
 — compressor, most important part of compression apparatus, 50, 57
 — for balloons, use of refrigeration for purification of, 472
 — motor, advantages of, for driving small refrigerating machines, 307, 308
 Gases, Charles' law of expansion of, 12
 — laws of, 12-14
 — liquefaction of, 588-601
 — Lussac's law of expansion of, 12
 Gasoline, use of, as a refrigerating agent, 44
 Gasworks breeze, use of, for insulating purposes, 329
 Gay, C. M., arrangement for circulating air, 318
 General law governing production of cold by frigorific mixtures, 23
 Generator for absorption machine, 171, 174, 185, 193, 204, 209, 210
 Germany, use of cork in, as a non-conductor, 329
 Germs of fungus or mould in atmospheric air, 313
 Giffard cold-air machine, 215, 222-224, 244
 Gill, pipe, 268, 269
 Gland of carbonic acid machine, to pack, 556
 Globe expansion valve, 247
 Gobert method of using refrigeration for constructional work, 477-483
 Godell, Henry Carr, use of lampblack as an insulating material, 330
 Gorman improvements in absorption machines, 193
 Gorrie, cold-air machine, 214
 Gothenburg, milk shipped to London from, 6
 Gottbrecht, Dr., experiments on properties of ammonia, 276
 Grapes, cold storage of, 388, 389, 394
 — trade in, 6

Gravity air circulation in cold rooms or chambers, 314-319
 — apparatus for lowering carcasses, 380
 Greatest theoretical efficiency of a refrigerating machine, 17
 Great Southern and Western Railway, Ireland, refrigerator car, 367
 Green vegetables, cold storage of, 390

HABRIER, experiments in liquefaction of gases, 588
 Hainault coalfield, refrigeration for shaft-sinking at, 475
 Hair-felt, use of, for insulating purposes, 329
 Hall, cold-air machines, 233, 234, 292, 293
 — J. & E., Ltd., carbonic acid compression machines, 131-141
 — cold-air machines, marine types, 415, 416
 — — duplex horizontal carbonic acid compressor, 139-141
 — — marine types of carbonic acid machines, 397-401
 — plan for chilling and freezing on wall system, 294, 295
 — — small vertical self-contained carbonic acid machine, 132-133
 — — single-cylinder double-acting horizontal carbonic acid compressor, 138
 — — steamers fitted with refrigerating machinery for the butter trade, 6
 — — to charge and work carbonic acid machine of, 554-556
 — system for cooling milk, 425-428
 Hampson, production of liquid air by, 593, 595-599
 Hanbury. *See* Truman, Hanbury, & Co.
 Handling ice, 536, 537
 Hand-power ice-making machine, 33
 Hargreaves and Inglis cold-air machine, 224
 — *See also* Hick Hargreaves
 Harrison ether machine, 2, 38-40
 — — — erected at brewery, first, 439
 — — — in paraffin works, 439
 — James, ether compression machine, 38
 — — improved vacuum apparatus, 29-31
 — vacuum machine, cost of making ice with, 584
 — *See also* Twining and Harrison
 Haslam air agitation ice plant, 502
 — ammonia valves, 256
 — atmospheric or open-air evaporative surface condenser, 160
 — beef chilling room fitted with patent brine-cooling batteries, 301-303
 — blast furnace installation, 466-469

- Haslam brine concentrator, 534
 — carbonic acid compressors, 149-151
 — cold-air machines, 225-230, 244, 415
 — — — at London and St Katherine Dock, 272-274
 — — — for marine work, 415
 — cold storage chamber, small, 306-308
 — distilling apparatus, 512
 — formula for ascertaining amount of air delivered by cold-air machine, 245
 — Foundry and Engineering Co., Ltd., marine types of ammonia compressors, 97, 404-407
 — open water cooler, 168
 — Sir Alfred Seale, apparatus for cooling air, 294, 295, 420, 421
 — — improvements in ammonia compressors, 93-97
 — water-cooling tower, 173
- Head, safety compression, 66-79
- Healthy working of ammonia machine, signs of, 541
- Heat and temperature, distinct meanings of, 10
 — calculations made in respect of, 11-19
 — conducting power of various substances, slate being 1,000, 342
 — definitions of, 8-10
 — discovery of, 8
 — exchanger. *See* Temperature exchanger
 — generated by compression, misleading nature of phrase, 16
 — latent, 10, 11
 — mechanical equivalent of, 11, 18
 — pump, refrigerating, machine, a, 19
 — sensible, 10
 — specific, 10
 — — and composition of victuals, 383
- “Heating by Hot Water,” experiments regarding heat-conducting properties of various substances, 341
- Hendrick’s condenser, 165-168
- Henry Vogt Machine Co., absorption machine, 196, 197
- Hercules discharge and suction valve, 259
 — Ice-making and Refrigerating Machinery Co., ammonia compressor, 106-108
- Hick Hargreaves, cold-air machine, 224, 225
- Hickmann, Ltd., refrigerating installation, 466-469
- Hill, F. B., arrangement of cold store or chamber, 290-292
 — arrangement for removing snow or hoar frost from refrigerating surfaces, 292
- Hill and Gorman, improvements in absorption machines, 193
 — and Sinclair, improvements in absorption machines, 193
 — Frederick Barker, improvements in absorption machines, 193, 194-196
 — method of making clear or crystal ice, 499-502
- History of trade in frozen meat, 2, 3
 — of fresh provision, 1-7
- Hoar frost, removal of, from refrigerating surfaces, 292
- Hoisting and conveying machinery, 372-380
- Hoists. *See* Elevators or Hoists
- Holden system of ice-making, 507, 508
- Holds of vessels, cooling of, 473
- Hollow or semi-cylindrical door for cold storage chamber, 310-312
- Hopkinson, Dr, on cost of making ice with Windhausen machine, 583, 584
 — description of Windhausen machine, 27-29
- Hops, cold storage for preservation of, 456
- Horizontal duplex marine type carbonic acid machines, 398-401
 — pipe, mercury well for, 563
- Hospitals, cooling of atmosphere of, in warm climates, 472
- Hot beer wort, refrigeration of, 444-446
 — climates, simple methods of producing cold in, 25
- Hotel, arrangement of refrigerating plant in, 309-312
- Houses, ice, ceilings for, 356, 357
 — — floorings for, 356
- Houssu coalfields, use of refrigeration for sinking shafts at, 475, 476
- Hübner. *See* Wegelin and Hübner
- Humboldt, ammonia compressor, 83
 — sulphurous anhydride compressor, 129
 — carbonic acid compressor, 149
 — meat-cooling plant, 303
 — milk-cooling arrangement, 428
- Humidity, correct relative, for a given temperature in egg rooms, 387, 388
- Hydrants, advisability for provision of, in ice factory, 530
- Hygrometers, 571
- ICE and Cold Machine Co., absorption machine, 197, 198
 — and refrigeration, articles on circulation of air in cold storage chambers, 313-328
 — apparatus for manufacture of, 62
 — can hoist for small plants, 525

- Ice cans or moulds, 27
 — crushing or breaking machinery, 537, 538
 — cube, 530
 — dump, automatic, 525-527
 — effect of a coating of, on expansion pipes, 560
 — elevating and conveying machinery, 520-529
 — factories, 518-529
 — — advisability for provision of hydrants in, 530
 — — approximate cost of operating, 586
 — houses, ceilings for, 356, 357
 — — flooring for, 356
 — making, 484-538
 — — cost of, 579-587
 — — in breweries, 457, 458
 — — machine, American, 22
 — — machines, management of, 539-578
 — — — testing of, 562-566
 — — or congealing tanks, marine, 416, 417, 418, 419
 — — vacuum system of ice-making, 517, 518
 — — various methods of, 485
 — packing, 535-537
 — properties of, 484
 — stores, refrigeration of, 535
 — — ventilation of, 535
 — tanks and refrigerator combined, Pictet's, 45
 — water. *See* Attemperating
- Ideal Refrigerating and Manufacturing Co., ammonia compressor, 105
- Illinois Central Railway, refrigerator car on, 368-370
- Imitation of natural system of ice-making, 518
- Imperfections of first absorption machines, 174, 175
- Important part of ammonia machine, most, 50-56
- Imports of butter, 6
 — of cheese, 6
 — of chilled beef, 3, 5
 — of frozen carcasses, 3, 4
- Improved Carré hand-power ice machine, 32
- Improving air circulation, means for, 327, 328
- Inclosed types of ammonia compressors, 73-77, 87, 114-116
- Increase the effective surface of cooling pipes, to, 268, 269
- Incrustation on condenser coils, 560-562
- India Docks, London and, 274
 — simple method of making ice in, 25
 — West, Docks, lifts at, 378
- India-rubber packings for ammonia compressors, 553, 554
 — works, use of refrigerating machinery in, 472
- Indicator diagrams, 63-66, 71, 237, 238, 566-569. *See also* Diagrams
- Industrial applications, 439-483
- Inflation of balloons, use of refrigeration for purification of gas for, 472
- Inglis. *See* Hargreaves and Inglis
- Injections of sealing and lubricating oil into compressor cylinder, 53
- Inlet valves, 256-260
- Inspection of cold storage space on board ship, 417
- Instructions to surveyors *re* carbonic acid machines, Board of Trade, 397
- Insulating structures, transmission of heat through various, 340
- Insulation, 329-371
 — door, 357-361
 — of marine installations, 409, 411, 412
 — methods of, used in U.S., 365
 — tank, 360-364
 — window, 360
- Interlaced type of condenser, 160
- Internal arrangement of cold stores, 285
- Interpretation of compressor diagrams, 566-569
- Introduction, 1-7
- Inventions for refrigerating and ice-making, various, 20
- Iron, ammonia no chemical action on, 276, 277
 — ceilings, cellars with, 306
- J**ACOBUS, Professor, latent heat of air, 599
- Jamaica, transport of bananas from, 3
- Jamieson, Professor Andrew, experiments by, on conductivity of substances, 332, 333, 334
- Jib, crane, long, for raising carcasses from barges, 378
- Johnson and Whitelaw's absorption machine, 209
- Joints, breaking of, in ammonia machines, 551, 552
 — pipe, and unions, 260-268
- Joint socket bend, soldered, 265
- Jones, Walter, experiments regarding non-conducting properties of various substances, 341
- Joule on production of very low temperatures, 594
- Joule's mechanical equivalent of heat, 11
- Juice, precautions to prevent loss of, from frozen mutton, 286

- KELVIN**, on production of very low temperatures, 594
- Kieselguhr, result of tests as to conductivities of, 333, 334, 335
- use of, as an insulating material, 329, 330
- Kilbourn ammonia compressor, inclosed type, 87-89
- cream cooler, 425
- improved type of ammonia compression machine in dairy, 425
- marine ice-making or congealing tank, 418, 419
- — type of ammonia compression machine, 407-409
- M. J. K., inventor of improvements in refrigerating machinery, 88
- pipe joints, 262-264
- stop-cock, 253
- Kingdom, United, cold stores in, 7
- Kingsford, improvements in vacuum machines, 26
- Kirk, Alexander, cold-air machine, 215
- Dr A. C., application of ether machine to extraction of paraffin from shale oil, 439
- Klein oil separator or collector, 509
- water-cooling tower, 170
- “Knight’s Dictionary,” description of Van der Weyde’s machine, 44
- Koch method of using refrigeration for constructional work, 477
- Kroeschell Bros. Ice-Making Co., carbonic acid compressor, 144-149
- — horizontal belt-driven carbonic acid compression machine, 147-149
- — rope-driven carbonic acid compressor, 140
- — vertical belt-driven carbonic acid compression machine, 147-149
- L**AGER beer fermenting rooms and store cellars, cooling of, 450
- La Hire’s epicycloidal device, 224
- Lampblack, use of, for insulating purposes, 330
- Land installations, Linde machine especially designed for, 80
- Langé’s improved pump for vacuum machine, 29
- Latent heat, 10, 11
- heat, discovery of, 10
- — of ammonia, 48
- Laundries, use of refrigeration ice, 472
- Laurensen, method of making ice, 496
- Lavoisier ice calorimeter, tests of conductivity with, 336
- Law, general, governing production of cold by frigorific mixtures, 23
- Laws of gases, 12-14
- Lawton, Mr A. W., process for preserving fruit, 389, 390
- Leakage at joints, cocks, valves, &c., in direct expansion system, 276
- of gas past piston rod, methods of preventing, 80, 83, 84, 94, 102, 103
- — past piston rod, stuffing box, and gland, Linde method of preventing, 72, 73
- See also Piston rod
- Leaks in ammonia apparatus, 559
- in carbonic acid machines, 560
- Lebrun, Mr B., cooling pipe with gills or flanges, 269
- — inclosed type of compressor, 116
- Lemons, cold storage of, 388, 394
- Leslie, improvements in vacuum machines, 26
- Lifts. See Elevators or Hoists
- Lightfoot cold-air machine, 230-233
- insulation recommended by, 329
- T. B., ammonia compressor, 91
- — cold-air machine, 230-234
- — — use of, for chocolate cooling, 440
- combined refrigerating and ice-making tank, 507
- — condenser, 155
- — experiments on heat conductivity of slag wool and charcoal, 342, 343
- — observations by, on frigorific mixtures, 23
- — on cold-air machines, 212-214
- — on cost of working, 580, 581
- — particulars regarding ether machine, 42, 43
- — results of tests with Linde compression machine, 80
- Lighting cold stores, 576-578
- Ligny-les-Aire, use of refrigeration for sinking shafts at, 476, 477
- Lime, cold storage of, 388
- Limit to ratio between diameter and stroke in ammonia compressors, 55
- Linde, Carl, ammonia compressors, 79-83
- — method of agitating water during freezing, 492
- Company, water-cooling tower, 172, 173
- marine type ammonia compression machine, 402, 403
- production of liquid air by, 593
- Lineal feet of 1-in. piping required per cubic foot of cold storage space, 282
- Liquefaction of a solid, abstraction of heat by, 20

- Liquefaction of gases. *See* Production of very low temperatures
 — process, *the*, 20-24
 — use of, by the ancients for refrigerating purposes, 21
- Liquefactor. *See* Condenser
- Liquefied agent, arrangement for removing, from condenser, 159, 160
- Liquefier. *See* Condenser
- Liquid air, cooling van by means of, 371
 — — — *See* Production of very low temperatures
- Liquor ammonia, strength of, 49
- Live cattle, cooling holds of vessels for, 473
- Lobrist, John, refrigerator car designed by, 370, 371
- London and India Docks Co., refrigerating installation at, 274
 — and Tilbury Lighterage Co., refrigerated barges, 421
- Long-distance thermometers, 573, 574
- Loose tools required in an ice factory, 529
- Lorenz, Hans, interpretation of compressor diagrams, 566-569
- Lowe, carbonic acid machine, 46
- Low-pressure refrigerating agents. *See* Ether, Methyl chloride, Sulphurous acid
- Low, Professor D. A., construction of chart applicable to any value of n , 14-16
- Low temperatures, production of, 588-601
- Lubrication of refrigerating machinery, 558, 559
 — qualities of ammonia, 552
- "Lucania," refrigeration of cargo holds of, 409-411
 — — of provision stores of, 411-413
- Lugo and M'Pherson, cold-air machine, 224
 — *See also* Tuttle and Lugo
- Lussac's law of expansion of gases, 12, 13
- Lyon's improved absorption machine, 200-203
- M**ACDONALD, Mr C. A., ammonia compressor designed by, 106-108
- Mach, Dr Ernest, on heat, 9
- Machines, absorption, 20
 — ammonia compression, 51-116
 — carbonic acid compression, 45-49
 — capacity of, required for refrigeration of cold storage chamber, 286-289
 — cold-air, 20, 211-245, 415-417
 — ether compression, 37-44, 117-120
 — liquefaction process, 21, 22
- Machines, methyl chloride compression, 120
 — sulphurous acid compression, 120-129
- Mackay and Christiansen, improvements in absorption machines, 175, 184, 185
 — Frederick Noel, arrangement for cooling cold storage rooms or chambers, 292
 — — — improvements in absorption machines, 184, 185
- M'Pherson. *See* Lugo
- M'Rae, Mr J., rotary chocolate cooler, 443, 444
- Main function of refrigerating and ice-making apparatus, 19
 — items of expense in working, 579
- Management and testing of refrigerating machinery, 530, 539-578
 — cold-air machines, proper, 562
- Manufacture of chloride of calcium and salt solutions, 532-534
- Manufacturing industrial and constructional applications, 439-483
- Maquet gilled piping, 269
- Marcet, Alex., rate of passage of heat through various materials, 329
- Marchant cold-air machine, 215
- Marine refrigeration, 396-421
- Mariotte's law, 18
- Martindale, Colonel B. H., on refrigerating chambers at St Katherine's Docks, 272
- Marvin hygrometer, 572
- Mash tuns refrigerated, 445, 446
- "Mataura," cargo of frozen meat in, 2
- Matthews, F. F., amount of refrigeration required, 381-383
 — — can ice, time required for freezing, 491, 492
 — — modern absorption machine, 205-209
 — — plate or wall system, 495
- Maurs' experiments on transmission of heat, 344, 345
- Maxwell, absolute zero, 12
 — definition of heat, 9, 10
- Means for improving air circulation, 316-319
 — increasing cooling surface of pipes, 268, 269, 292
 — preventing leakage at compressor piston rod, 80, 83, 84, 94, 102, 103
- Meat-carrying chamber on board "Campania" and "Lucania," 409-411
- Meat, cold storage of, 363
 — frozen, history of trade in, 2
 — cooling plant, abattoir, Riga, 303

- Meat, trade in frozen, 2
 Meats and fish, freezing and storing of, 383-385
 Mechanical equivalent of heat, 11, 18
 — or forced air circulation, 319-328
 — refrigeration, theory and practice of, 8-20
 — — work demanded of a machine for, 13, 14
 Mediums, refrigerating. *See* Agents
 Melbourne, first cargo of apples from, 6
 Mercury well for horizontal pipe, 563
 — — for vertical pipe, 563, 564
 Method for preventing leakage of gas past compressor piston-rod, 80, 83, 84, 94, 102, 103
 — of testing capacity of refrigerating machine, 562-566
 Methods of ice-making, various, 485-508
 — of piping that hinder circulation, 313-316
 Methyl chloride, advantages of, as a refrigerating agent, 120
 — — composition of, 120
 — — compression machines, 120
 — — disadvantages of, as a refrigerating agent, 120
 — — properties of, 120
 Methylic ether compression machine, 40-42
 — — compression machine, expansion valve for, 42
 — — distilling apparatus, 40
 Meyer steam engine for driving ammonia compressor, 114
 Mica, use of, as an insulating material, 329, 367
 Mild-cured bacon, use of refrigerating machinery for production of, 306
 Milk, refrigeration of, 386, 422-438
 — shipped from Gothenburg to London, 6
 — trade in frozen, 6
 Mirrlees, Watson, & Yaryan Co., distilling apparatus, 514-517
 Miscellaneous arrangements for making clear or crystal ice by agitation, 499-507
 Mixer for making brine, 532, 533
 Mixtures, freezing, principal, 24
 — frigorific, observations on, 23
 Modern physicists on heat, 9
 — types of Boyle ammonia compressors, 97
Mois Scientifique et Industriel. See Maurs
 Moissau, experiments by, in liquefaction of gases, 592
 Moisture in air, determination of, 470-473
 Moisture properties of absorbing gases, 313
 Molesworth, heat-conducting power of various substances, 342
 Mollet, Fontaine, et Cie, carbonic acid compressor, 151
 Morgues, refrigeration in, 391
 Mort, improvements in absorption machines, 175, 181
 — temperature exchanger, 181
 — *See also* Nicolli and Mort
 Morton, Professor Henry, on power obtainable by expansion of liquid air, 599-601
 Mortuaries. *See* Morgues
 Mouge, experiments by, in liquefaction of gases, 588
 Mould, germs of, in atmospheric air, 313
 Moulds, cold slabs or tables for, 193, 194
 — or cans, ice, 27
 Multiple effect distilling apparatus, 510-517
 Mutton, frozen, hanging before cooking, 286
 — hoist, electrically-driven, 376

 N AIRNE vacuum machine, 26
 Nalder Brothers & Thompson, Ltd., telethermometer, 575, 576
 Naphtha, use of, as a refrigerating agent, 44
 Natteur, experiments in the liquefaction of gases, 588
 Natural system of ice-making, imitation of, 518
 Neff, Mr Peter, on ratio of diameter to stroke in ammonia compressors, 56
 Nelson's cold storage wharf, external carcass hoists at, 376-378
 Nessler's reagent, 559
 Neubecker ammonia compressor, 85
 "Neuere Kuehlmaschinen," interpretation of compressor diagrams, 566-569
 New South Wales, imports of butter from, 6
 — — — imports of frozen meat from, 2
 — — Zealand, imports of frozen beef from, 2
 — — Shipping Co., refrigerating installation, 407
 — — use of pumice stone as an insulating material in, 329
 Niagara Hall, artificial ice skating rink at, 473
 Nicolli and Mort's improvements in absorption machines, 210
 Nishigawa improvements in absorption machines, 193

- Non-conducting materials, experiments on transmission of heat through, 344, 345
- Non-conductive values of different materials, results of tests as to, 337, 338
- Non-heat-conducting properties of various substances, 337, 340
- "Nonpareil," first cargo of West Indian fruit in, 3
- Northmore, experiments by, in the liquefaction of gases, 588
- Number of cubic feet covered by 1 ft. of 1-in. iron pipe, 282
- of cubic feet covered by 1 ton refrigerating capacity, 283
- of firms directly interested in refrigeration, 7
- of vessels fitted with refrigerating machinery, 7
- O**BJECTIONABLE features of can system of ice-making, 488-490
- Objections to the cold-air machine, 242, 243
- double pipe condensers, 165
- to the use of ether as a refrigerating agent, 43, 44
- Observations on frigorific mixtures, 23
- "Oceana," first cargo of apples in, 3
- Oil for lubricating ammonia machines, 542
- injection of sealing and lubricating into compressor cylinder, 53, 56-66
- presence of, in ammonia system, 542
- separators or collectors, 76, 509, 510, 544-549
- Olszewski, experiments by, in liquefaction of gases, 591
- Onions, cold storage of, 390, 391, 394
- Onnes, experiments by, in liquefaction of gases, 592
- Opaque ice, reasons for, 484, 485
- Open-air condensers. *See* Atmospheric condensers
- Opening up ammonia machines, necessary precautions, 52
- — carbonic acid machines, necessary precautions, 556
- Open trough system of cooling, 302, 303
- water cooler, 168
- Operation of absorption machine, 178, 179, 205-209
- of Frick safety compression head, 68-70
- Operations, cycle of, in ammonia compression machines, 52
- Oranges, cold storage of, 388, 394
- Ordinary form of atmospheric condenser, 158
- — of cream cooler, 430
- Ordway, Professor John M., experiments by, on non-conducting coverings, 304
- — experiments regarding non-heat-conducting properties of various substances, 340
- "Orient," cargo of frozen meat in, 2
- Origin of artificial refrigeration, 1
- Orosius on production of cold by Esthonian tribe, 21
- Oscillating ice-making tank or box, 504
- Oxydising of tea, regulation of, by refrigeration, 464
- P**ACIFIC Coast, salmon-freezing works on, 384
- Packing carcasses in cold rooms or chambers, 271, 286
- house, cubic feet of space per running foot of piping, 281
- ice, 535-537
- Packings, compressor piston-rod, 552-554
- in ammonia compressor stuffing boxes, to drive home, 554
- Pamely, Caleb, on Gobert method of congelation for constructional work, 477-483
- Paper or cloth, hard pressed asbestos, value of, as an insulating material, 335
- use of, for insulating purposes, 331
- "Para," accident on board, 390
- Paraffin oil works, refrigeration in, 459-461
- solid, extraction of, from shale oil by refrigeration, 459-461
- Paris Exhibition, carbonic acid compressor at brewery section, 151
- Parsnips, cold storage of, 391, 395
- Partially submerged pump or piston agitator, 358, 359
- Particulars regarding ether machine, 42-44
- Partitions, divisional, for cold stores, 353, 354
- Parts, main, required in all compression machines, 36, 37
- required in ammonia compression machines, 51
- Pasteurisation of milk in dairies, 431
- Pastry, cold slabs or tables for the manufacture of, 193, 194
- Patent system of preventing leakage at ammonia stuffing boxes, 554

- Peaches, cold storage of, 389, 395
 — trade in, 6
 Pears, cold storage of, 388, 395
 — trade in, 6
 Peninsular and Oriental Co.'s cold storage chamber, 418
 Periodical publications dealing wholly or partly with refrigeration, 604
 Perkins', Jacob, first compression machine, 34, 35
 Photographic accessories, use of refrigeration in manufacture of, 471
 Physical constants of liquefied gases, 598
 Physicists, modern, on heat, 9
 Picteau fluid, 34
 Pictet ammonia compressors, 91, 92
 — experiments by, in the liquefaction of gases, 588, 591
 — Raoul, experiments by, on radiation at low temperatures, 331, 332
 — — heat units transmitted per square foot per hour, 330, 331
 — — sulphur dioxide, or sulphurous acid machine, 44, 45
 Pictet's improvements in absorption machines, 210
 Pictet. *See also* Tellier and Pictet
 Pieper, Mr., on amount of water used by Windhausen machine, 504
 Pipe joints and unions, 260-269
 Pipe-loft, or coil-room, system of air circulation, 318, 319
 — means for increasing cooling surface of, 268, 269
 — *See also* Cooling pipes
 Piping for cold stores, 280-284
 — methods of, that hinder air circulation, 313-316
 — breweries, 456, 457
 Piston or pump agitators for making clear or crystal ice, 504-507
 — rod, means for preventing leakage at, 80, 83, 84, 94, 102, 103
 — — packings, compressor, 552-554
 Pitch, use of, for insulating purposes, 330
 Plant growth, regulation of, by refrigeration, 472
 Plate, heat-units transmitted through, square foot per hour, 331
 — or wall system of ice-making, 485, 493-496
 — system of making clear or crystal ice, 485-508
 Poetsch process for sinking shafts by refrigeration, 475-477
 Points to be looked for in a water-cooling tower, 170
 Pontifex expansion or regulating valve, 249
 Pontifex gas-tight joint, 260, 261
 — E. L., improvements in absorption machines, 175, 186-198
 Pontifex-Wood absorption machine, cost of making ice with, 580
 — — — use of, in artificial butter works, 461-464
 — — absorption machine, use of, in brewery, 451-455
 — — — working of, 499, 500
 — brine refrigerator, 445
 — can ice-making tank or box, 487, 488
 — ice-making tank or box on wall or plate system, 493, 494
 — improvements in absorption machines, 175, 186-193
 — pyramid ice-making box, 487
 — stationary cell system of ice-making, 497-499
 Portable distilling apparatus, 516, 517
 Postle cold-air machine, 215, 216
 Power obtainable by expansion of 1 lb. of liquid air, 599-601
 Practice, limit in, between ratio of diameter and stroke in ammonia compressors, 55
 — theory and, of mechanical refrigeration, 8-20
 Precautions when opening up compression machines, necessary, 52, 555
 Preservation of dead bodies by refrigeration, 391
 — of furs and various fabrics by refrigeration, 472-473
 — of meat by refrigeration, 270-272
 Pressure, absolute, 11, 12
 — and boiling point of liquids available for use in refrigerating machines, 48, 117, 120
 — back, loss of efficiency in ammonia compressors from, 56
 Principal freezing mixtures, table of, 24
 Principle of the absorption machine, 174, 205-209
 Principles involved in process of refrigeration, simplicity of, 19
 — of operation of ammonia compressor, 51, 52
 Process, absorption, the, 201
 — compression, the, 18, 20, 34-151
 — liquefaction, the, 20, 21-24
 — vacuum, 20, 25-55
 Production of cold by frigorific mixtures, general law of, 23
 — of very low temperatures, 588-601
 Progress, history of trade in fresh provisions, 1-7
 Propeller for brine agitation, 490, 491

- Proper management of cold-air machines, 562
 — methods of storing, and temperatures for cold storage, 381-391
 Properties of ammonia, 48
 — carbonic acid, 129
 — ether, 117
 — methyl chloride, 120
 — sulphurous acid, 120
 "Protos," cargo of frozen meat in, 2
 Provisional specification of Dr William Hampson, 595
 Provision stores or chambers on board S.S. "Campania" and "Lucania," 411-413
 — trade, fresh, 1, 2
 Psychrometers, 571
 Publications, periodicals, dealing wholly or partly with refrigeration, 602-604
 Public buildings, cooling atmosphere of, in warm climates, 472
 — morgues or mortuaries, 391
 Pulsometer Engineering Co., Ltd., ammonia compressors, 85-87
 — — — cell ice-making tank or box, 499
 — — — cold storage chamber, 289, 290
 — — — cost of working, 582
 — — — hand-power ice machine, 33
 — — — ice delivery machines, 527
 — — — ice tank or box room of ice factory, 519, 520
 — — — ice-making box, 495, 496
 — — — refrigerated barges, 421
 — — — refrigerated railway van, 365
 Pumice stone, use of, as an insulating material, 329
 Pump agitator for making clear or crystal ice, 504-507
 — for clearing absorber, 188
 — for vacuum machine, improved, 29
 Puplett agitators for ice-can box, 488
 — ammonia compression machine in small store, 303, 304, 308
 — and Rigg, arrangement for lifting ice cans, 523-525
 — — patent separator, 545, 546
 — — regulating valve, 248, 249
 — marine type of ammonia compressor, 403
 — Samuel, improvements in ammonia compressors, 92, 93
 Puplett's water-saving and cooling apparatus, 168, 169
 Purification of gas for inflation of balloons, use of refrigeration for, 472
 Purity of carbonic acid, to test, 129
 Pyramid ice-making box, 487
- Q**UALITIES of ammonia, lubricating, 552
 — principal, to be sought for in compressor, 53, 56
 — rendering carbonic acid particularly suitable for use on ship-board, 397
 Quality of oil to be used for sealing and lubricating purposes in ammonia compressors, 57
 Queensland, imports of frozen beef from, 3
 Quiri & Co., atmospheric condensers, 161
 — — sulphur dioxide compression machines, 123, 124
- R**ABBITS, trade in frozen, 3
 Radiation of heat through walls of cold storage chambers, &c., 287-289
 Railway vans, refrigerated, 365-371
 Ransome and Rapier absorption machine, 198-200
 Raoul Pictet Co., sulphurous acid machine, 129
 — — — sulphur dioxide or sulphurous acid machine, 44, 45
 Rapid liquefaction of a solid, abstraction of heat by, 20
 Ratio between diameter and stroke of ammonia compressor, 54, 56
 Rau's atmospheric condenser, 161
 Reaumur's thermometrical scale, zero on, 12
 Reciprocating agitators for making clear or crystal ice, 487-499
 Red currants, cold storage of, 389
 Reece, Rees, improvements in absorption machines, 175, 179-181
 Refineries, sugar, refrigeration in, 464, 465
 Refrigerated railway vans, 365-371
 Refrigerating apparatus, amount of water required by, 570
 — capacities, table of, 284
 — capacity in B.T.U. required per cubic foot of storage, 283
 — coils, defrosting, 560, 561
 — machine a heat pump, 19
 — — greatest theoretical efficiency of, 17
 — — machinery, classification of, 20
 — — lubrication of, 558, 559
 — — testing of, 564-568
 Refrigeration, amount of, required in cold stores, 286-289
 — and cold storage, 270-395
 — bibliography of, 602-604

- Refrigeration by means of cold-air machines, 272, 274
 — — compression and absorption machines, 274
 — — chemical process of, 20, 21-24
 — in butter manufactories and dairies, 422-438
 — marine, 396-421
 — mechanical, theory and practice of, 8-20
 — — working of a machine for, 15, 16
 — number of firms directly interested in, 7
 — use of, in various industries, 439-483
 Refrigerator. *See* Evaporator
 Regealed ice machine, 507, 508
 Regenerative method of producing very low temperatures, 592-599
 Registering thermometers, 574, 575
 Regularity of temperature of fruit cargo, necessities for, 419, 420
 Regulating the temperature of fermenting of tea by refrigeration, 464
 — valves. *See* Expansion valves
 Regulation of plant-growth by refrigeration, 472
 Relative humidity for a given temperature in egg rooms, correct, 387, 388
 — — of air per cent., 572
 Remington Machine Co., single-acting inclosed pattern ammonia compressor, 99, 100
 Results of experiments on the conductivities of various substances, 336
 — — regarding heat-conducting properties of various substances, 339, 340
 — — regarding non-heat-conducting properties of various substances, 340, 341
 — of tests to determine the non-conductive values of different materials, Donaldson, 337, 338
 — — — the non-conductive values of various materials, Wallace, 338
 — of tests on the heat-conductivity of different substances, 339, 340
 Return socket bend, 265, 266
 Revolving door for cold storage rooms, 310-312
 Rhigoline, use of, as a refrigerating agent, 43
 Rice, Mr A. L., on production of very low temperatures, 593, 594, 599
 Richardson, Dr B. W., on effect of ammonia on fresh meat, 276, 277
 Rich, H. S., & Co., work on eggs in cold storage, 388
 Riga abattoir meat-cooling plant, 303
 Rigg, Jonathan Lucas, improvements in ammonia compressors, 92, 93
 — *See* Puplett and Rigg
 Rilleux, triple-effect distilling apparatus, 510
 Rink, artificial surfaces of ice at, 473
 River Plate, imports of frozen mutton and beef from, 3, 5
 Rocking or oscillating ice-making tank or box, 504
 Romans, cooling of wine by, with salt-petre, 21
 Roscoe, Sir Henry E., on carbonic acid, 47
 Rossi. *See* De Motay and Rossi
 Rotary agitators for making clear or crystal ice, 487
 Rotating discs, arrangement for cooling air with, 297
 — door for cold storage rooms, 310-312
 — exhaust pump or cylinder, 30
 Rough estimate of refrigeration in breweries, 457
 "Ruapehu," refrigerating installation on board of, 407
 Ruddick, J. A., on dairy refrigeration, 431-436
 Rugs, preservation of, by use of refrigeration, 472
 Rumford, Count, definition of heat by, 8
 Ryan, T. J., refrigerator car, 371
- S**ABROE & CO., LTD., D., carbonic acid machine, 151
 — — Thomas Ths., sulphurous acid machine, 129
 Sacking saturated with cold brine, cooling air with, 297
 Safety devices for compressors, 71-76
 — heads for compressor cylinders, 66-74, 105
 — valves for carbonic acid machine, 135, 144, 146, 149
 Salmon-freezing works on Pacific Coast, 384
 Salsify, cold storage of, 391
 Sandbach, combined cream cooler and heater, 430
 Santorio, cooling wine by mixture of snow and salt, 21
 Saving of power and cooling water in condensers, 164, 165
 Schmidt, M. E., refrigerator car, 371
 — on Poetsch process of sinking shafts by refrigeration, 477
 Schmitz, Mr Constanz, method of testing capacity of refrigerating machine, 566, 567

- Schou, H. H., patent evaporator, 155
Scientific American, article on effect of ammonia on fresh meat, 276
- Screen or apron in front of side-wall piping, 316, 317
- Screw agitator. *See* Agitator
- Screwed and soldered joints, 261-266
- Seeley, improvements in absorption machines, 193, 209
- Self-contained marine type of ammonia compression machine, 407, 408
- Selfe, Norman, ammonia compressor, 108
- Self-registering thermometer. *See* Thermograph
- Selling ice, 536, 537
- Semi-cylindrical door for cold storage rooms, 310-312
- Semi-steel, use of, in compressor cylinder, 145
- Senssenbrenner, C., ammonia absorption machine, 203
- Sensible heat, 10
- Separators or collectors, oil, 76, 509, 510, 544-549
- Shafts, use of refrigeration for sinking, 472, 474-483
 — ventilating, for cold stores, 312
- Shale oil, extraction of solid paraffin from, by refrigeration, 460, 461
- Shallow stationary cell system of making clear ice, 485
- Shipley, Mr Thomas, improvements in St Clair compressor, 116
- Ships' holds, method of sterilising cold air for use in, 420, 421
- Siberian rivers, use of refrigeration for prospecting in, 477
- Siebe, Gorman, & Co., ether compression machine, 38-40, 43
- Sibel, Professor, amount of condensing surface required in atmospheric condensers, 156
 — — on cold storage of fruits, 388
 — — on dimensions of submerged condensers, 155
 — — radiation through walls, &c., 287
- Siemens' ice-making apparatus, 22
 — experiments by, in liquefaction of gases, 588, 592
 — liquefaction process, cost of making ice by, 584
- Silicate cotton. *See* Slag wool
- Silks, preservation of, by means of refrigeration, 472
- Simple method of procuring ice, used in France, 25
 — — of producing ice in hot climates, 25
- "Simplex" absorption machine, 198-200
- Simplicity of principles involved in process of refrigeration, 19
- Sinclair improvements in absorption machines, 193, 194
- Single-acting compressors, advantages of, 57
 — — disadvantages of, 51
 — — losses due to clearances in, 54, 55
 — compound marine type ammonia compressor, 407
 — effect, Yaryan distilling apparatus, 510-517
- Sinking of colliery shafts, application of refrigeration to, 472, 474-483
- Sizes and capacities of various ice-making plants, 532
- Skelp, condenser pipes made of, 161
- Skinkle, Eugene T., table of dimensions of atmospheric condensers, 157
 — — — of submerged condensers, 157
- Slabs or table, cold, for manufacture of chocolate, &c., 193, 194
- Slag wool, consistency for packing insulating spaces with, 330
 — — use of, as an insulating material, 329
- Small brewery, plan of refrigerating plant for, 458
 — cold storage chamber, with Haslam cold-air machine, 306-308
 — — — with Puplett ammonia compression machine, 308
 — — — with Triumph ammonia compression machine, 308, 309
- Snow, removal of, from refrigerating surfaces, 292
 — — — marine cold storage chamber, 417
- Société Genevoise de Construction, sulphurous acid machine, 129
- Socket bent joint, 265
 — — return, 265-267
- Soda-water works, use of refrigeration in, 472
- Sodium, chloride of. *See* Salt
- Soft fruits, trade in, 6
- Solid, abstraction of heat by liquefaction of, 20
 — paraffin, extraction of, from shale oil, by refrigeration, 459-461
 — steel forging for compressor cylinders, 144
- Solidification as a test for purity of carbonic acid, 129, 130
- Solway, regenerative method of producing low temperatures, 593
- Soudan Campaign, use of ether machine during, 120

- South Africa, use of ether machine in, 120
- Southampton Docks, cold stores or chambers at, 285, 286
- Cold Storage Co., elevators, 375, 376
- Southby. *See* Blyth and Southby
- South Wales, New, imports of butter from, 6
- — — imports of frozen beef from, 2
- Splattering of cooling water in atmospheric condensers, to prevent, 159
- Specific gravity of ice, 484
- heat, 10
- — and composition of victuals, 498
- — definition of, 10
- — of ice, 484
- — of water, 10
- Spiral agitator for can ice-making box, 487
- Spring safety compressor heads, 65-70
- Stallman's ammonia compressor, 105, 106
- Standard Butter Co., railway van cooled by liquid air, 371
- Stanley, H. F., improvements in absorption machines, 175, 181-184
- refrigerator car, designed by, 368-370
- Starr, transmission of heat through various insulating structures, 344
- Starting ammonia machine, 541
- Stationary cell system of ice making, 496-499
- St Clair compound ammonia compressor, 116
- — system of circulating air in cold chambers, 318, 319
- St Katherine Docks, refrigerating chambers at, 272-274
- Steel flange unions, 264
- Steinle thermometer, used on chocolate cooler, 443
- Sterne, L., & Co., Ltd., ammonia compressors, 56-66
- Stevenson's cold-air machine, 225
- Stewart & Co., Ltd., D., carbonic acid compression machine, 151
- Stewart Balfour on rise of temperature of air under compression, 10
- Still for absorption machine, 174. *See also* Generator
- Stocker water-cooling tower, 170
- Stockholm, construction of tunnel by refrigeration at, 474
- Stoddard, paper on waterproofing bricks, 345-350
- Stop-cocks and valves, 252-256
- Storage chambers, amount of refrigerating pipes required for, 280, 281
- of fruit cargo, proper, 418, 419
- Storage of various articles, proper temperature for, 392-395
- Stores, cold, number of, in United Kingdom, 7
- — walls for, 350-354
- Storing ice, 535-537
- meats and fish, 383-385
- Strainer, brine, 491
- Straiton, Mr John, door for cold storage rooms, 360
- "Strathleven," first cargo of frozen meat brought over in, 2
- Strawberries, cold storage of, 389
- Stroke, ratio between, and diameter in ammonia compressors, 54-56
- Stuffing boxes for ammonia compressors, 552-554
- box glands, sealing of, 56, 57
- Sturgeon's cold-air machine, 225
- Submerged condensers, 134, 152-157
- Successive cycle system of producing very low temperatures, 589, 590
- Suction and discharge valves, 256-260
- Sugar factories and refineries, use of refrigeration in, 464, 465
- machinery, treatise on, 465
- Sulphur dioxide. *See* Sulphurous acid
- Sulphuric acid refrigerating machines, 27, 33
- ether compression machine, 39, 40
- Sulphurous acid, advantages of, as a refrigerating agent, 44, 45
- — machine, 44, 45, 120-129
- — objections to use of, as a refrigerating agent, 45
- — properties of, 44, 45
- Sulzer engine, compressor pumps driven by, 81, 124
- Superheating of ammonia gas in compressor cylinder, means for preventing, 91
- Suppes and Dortch, expansion valve, 251, 252
- Supplementary condensers or forecoolers, 164, 165
- Surfaces, brick, waterproof coatings for, 345-350
- of cooling pipes, to increase, 268, 269, 292
- Swiss Co-operative Society refrigerating plant, 428, 429
- Sylvester process for waterproofing brick, 350
- System, absorption, the, 20, 174-210
- cold air, the, 211-245
- compression, the, 20, 34-151, 557, 558
- liquefaction, the, 20, 21-24
- Systems of operating ammonia compression machines, two, 52

- T**ABLE giving size and capacities of various ice-making plants, 523
- the extreme limits of cubic feet of space per running foot of 2-in. piping, 281
 - the relative heat-conductivity of various boiler-covering materials, 340
 - of amount of heat-units transmitted, per square foot per hour, through various substances, 330
 - of approximate cost of ice-making, 587
 - operating ice factories, 586
 - of calculated relative amounts of vapour condensed and deposited in the various stages of cooling, 230, 231
 - of conductivities of asbestos and Kieselguhr composition, 334
 - of correct relative humidity for a given temperature in egg rooms, 388
 - of cubic feet of ammonia gas per minute to produce 1 ton of refrigeration per day, 278
 - — of space per running foot of 2-in. pipe direct expansion, 281
 - of dimensions of atmospheric condensers, 164
 - — of submerged condensers, 157
 - of extreme limits of cubic feet of space per running foot of 2-in. piping, 281
 - of freezing times for different temperatures, and thicknesses of can ice, 530
 - of heat-conducting power of various substances, slate being 1,000, 342
 - of ice plant efficiencies, 531
 - of ice required for refrigeration in dairies, 435
 - of lineal feet of 1-in. piping required per cubic foot of cold storage space, 282
 - of non-heat-conducting properties of various substances, 340
 - of number of cubic feet covered by 1 ft. of 1-in. iron pipe, 282
 - of number of cubic feet covered by 1-ton refrigerating capacity for twenty-four hours, 283
 - of physical constants of liquefied gases, 598
 - of principal freezing mixtures, 24
 - of rate of passage of heat through various materials, 339
 - of ratio of piping in brewery cellars, 456, 457
- Table of refrigerating capacities, 284
- capacity required per cubic foot of storage room, 283
 - refrigeration required to cool meats, 382
 - of relative humidity for given temperature in egg rooms, 388
 - — per cent., 572
 - of results of different experiments on the heat conductivities of various substances, 336
 - — of experiments regarding non-heat-conducting properties of various substances, 340, 343
 - — of test experiments made with cold-air machines, 244
 - — of tests to determine the non-conductive values of different materials, 337, 338
 - — of tests to determine the non-conductive values of various materials, 338
 - — of tests on the heat conductivity of different substances, 339
 - — of tests by Professor Jamieson as to relative and absolute thermal conductivities of substances, 333
 - of specific heat and composition of victuals, 383
 - of temperatures adapted for the cold storage of various articles, 392-395
 - of tests of waterproofing bricks, 345-350
 - of time required for water to freeze in ice cans, 491, 531
 - of weights of aqueous vapour held in suspension in pure dry air, 573
 - of yearly imports of frozen and chilled beef, 5
 - of yearly imports of frozen mutton and lamb, 3, 4
 - showing transmission of heat through various insulating structures, 344
- Tables or slabs, cold, for manufacture of chocolate, &c., 193, 194
- Tabor, C. J., on preservation of fish, 384, 385
- Tancredus, Latinus, freezing water by mixture of snow and saltpetre, 21
- Tangye pattern frame ammonia compressor, 108, 109
- Tank insulation, 361-364
- Tapestries, preservation of, by means of refrigeration, 472
- Taylor. See Wallis-Taylor
- Taylor's patent fittings for doors of cold stores, 360

- Tea regulating, fermenting of, by refrigeration, 464
- Telethermometer, or electrical thermometer, 575, 576
- Tellier and Pictet machines, cost of making ice with, 583
- Charles, methylic ether compression machine, 40-42
- Tell-tales. *See* Temperature tell-tales
- Temperature absolute, 12
- and heat, distinct meanings of, 10
- best, to maintain a fruit cargo, 419
- exchanger and economiser, 181, 197
- of condensed gas most economical, 168
- of oxydising or fermentation of tea by refrigeration, 464
- tell-tales and long distance thermometers, 573, 574
- Temperatures for the cold storage of various articles, proper, 392-395
- production of very low, 588, 601
- Tender fruits, cold storage of, 388
- Testing of refrigerating machinery, 563-576
- work of carbonic acid machine, 481
- Tests of purity of carbonic acids, 129-131
- of waterproofing brick, 345-350
- Thames, refrigerated barges on, 421
- Theoretical efficiency of a refrigerating machine, greatest, 17
- Theory and practice of mechanical refrigeration, 8-20
- Thermo-dynamics, first laws of, 8-19
- Thermographs, 419, 574, 575
- Thermometers, long distance, 573, 574
- Thermometrical scale, Fahr., zero on, 12
- Thomas, F. S., arrangement for increasing the surface of cooling pipes, 292
- Thompson, Benjamin. *See* Rumford
- M. R., on filling ice houses, 335
- Thorne, method of making ice, 495
- Time required for water to freeze in ice cans, 491, 531
- Tomkins, E. H., improvements in absorption machines, 175, 185, 186
- Tools, loose, required in ice factory, 529
- Toselli's ice-making machine, 22
- Tower, air-cooling, 295-297
- water-cooling, 168-173
- Track system for ice factories, 527
- Trade in Australian apples, 6
- in fresh provisions, 1-7
- in frozen cream, 6
- in frozen meat, 2
- Trade in grapes, 6
- in peaches, 6
- in pears, 6
- Trans-Mississippi Exposition, refrigerating machine at, 110, 111
- Trays, drip. *See* Drip trays
- Triple-effect distilling apparatus, 510-512
- Tripler's apparatus for the production of very low temperatures, 593-595
- Triumph Ice Machine Co., approximate cost of ice-making, 587
- atmospheric condenser, 160
- automatic ice dump, 525-527
- complete brewery refrigerating plant, 458
- dimensions of submerged condensers, 155, 156
- discharge and suction valves, 259, 260
- double-acting ammonia compressor, 89-91
- expansion valves, 247, 252
- oil separator or collector, 509, 549
- plan of ice factory, 520
- plan for insulation, 365
- propeller for brine agitation, 490, 491
- small cold storage room, 308, 309
- stop-valve, 253, 254
- water-cooling tower, 171, 172
- Tropical climates, cooling of hospitals, &c., in, 472
- Trotter, Mr A. P., long distance thermometer, 574
- Trough, open, system of cooling, 303
- Truman, Hanbury, & Co., brewery, first use of ether machine at, 439
- Trunk for admitting cold air in marine installations, 416, 417
- Trunks or ducts, Puplett's arrangement of, 303, 304
- Tunnelling, application of refrigeration to, 474
- Tuttle and Lugo, cold-air machine, 224
- Tuxen and Hammerich Engineering Works, Ltd., ammonia compressor, 100-102
- carbonic acid compressor, 151
- Twining and Harrison, wall or plate system of ice making, 493
- Professor, improved compression machine, 37, 38
- Tyler and Ellis Manufacturing Co., Ltd., ammonia absorption machine, 198-200
- Tyndall, Professor, definition of heat by, 9

- UNIONS**, flange, 264-269
 — pipe joints and, 260-269
 United Kingdom, cold stores in, 7
 — — imports of frozen provisions into, 1-7
 — States, construction of first refrigerator car in, 366
 — — Illinois Central Railway, refrigerator car on, 367-370
 — — method of freezing fish in, 383, 384
 — — — insulation used in, 365
 — — pattern of Linde ammonia compressor made in, 81
 — — refrigeration in, 7
 — — selling and delivering of ice in, 536, 537
 — — water-cooling towers in, 168-173
 Unit of measure of heat, 11
 Unnecessary clearance spaces in ammonia compressor, 53-56
 Upholstered furniture, preservation of, by refrigeration, 472
 Utilisation of dissolution of a solid to abstract heat, 20, 21-24
- VACUUM** flasks for liquid air, 591
 — machine, cost of making ice by, 584
 — — improved pump for, 29
 — process, the, 20, 25-33
 — system of ice making, 517, 518
 — — of refrigeration, the, 20. *See also* Vacuum process
 Vallance, improvements in vacuum machines, 26
 Valves, safety, 52, 54, 135, 144, 146, 149
 — compressor, unnecessary clearance spaces, 56
 — discharge, 256-260
 — expansion, 42, 53
 — inlet, 256-260
 — suction, 256-260
 — *See also* Cocks, Valves, &c.
 Value of different substances, non-conductive, 337, 338
 Van der Weyde refrigerating machine, 44
 — — system of packing ice, 530
 Vans, railway, refrigerated, 365-371
 Vapour, method of cooling in compression cylinder, 80
 — *See also* Gas
 Various articles, proper temperatures for cold storage of, 381-395
 Various insulating structures, table showing transmission of heat through, 344
 — inventions for refrigerating and ice-making, 20
 — manufacturing, industrial, and constructional applications of refrigeration, 438-483
 — methods of ice-making, 485-508
 — substances, results of experiments on the heat conductivity of, 331, 336
 — — of tests on the heat conductivity of, 333
 — — used for purposes of insulation, 329-371
 Vault in brewery, cooling of, 451
 Vegetables, cold storage of, 390, 391
 Vendin-Sens, use of refrigeration for sinking shafts at, 475
 Ventilation of cold storage chambers, 312, 313
 Ventilating shafts for cold stores, 312
 Vernon, Mr C. E., electric temperature tell-tales, 573, 574
 Vertical duplex marine type of carbonic acid machine, 401
 — marine types of cold-air machines, 414-417
 — — type of single-acting ammonia compression machine, 402
 — pipe, mercury well for, 563
 Very low temperatures, 588-601
 Vessels carrying live cattle, cooling holds of, 473
 — fitted with refrigerating machinery, number of, 7
 Vicq-Auzin, use of refrigeration for sinking shafts at, 475
 Victoria Dock, lifts at, 378
 — — imports of butter from, 6
 — — imports of frozen beef from, 3
 Victorals, specific heat and composition of, 383
 Villafranca, Blasius, use of saltpetre by, for the reduction of temperature, 21
 Vilter Manufacturing Co., ammonia compressor, 81-83
 Vogt Machine Co., Henry, improved ammonia absorption machine, 196, 197
 Volatile liquid agents, 34
 Voorhees, Mr Gardner F., oil separator or collector, 547
 V-shaped or corrugated bottom to cooling tank, 291, 292
 Vulcan Iron Works, amount of water required in refrigerating apparatus, 570

- Vulcan horizontal double-acting ammonia compression machine, 112-114
 — ice factory, 520
 — inclosed type ammonia compressor, 114, 115
 — track system, 527
- W**AGONS, refrigerated. *See* Vans
 Walker laboratory ice-making machine, 22
- Wallace, Dr Wm., results of tests by, to determine non-conductive values of various materials, 338
- Wallis-Taylor and Whitehead, revolving door for cold stores, 310-312
 — tests conducted by, on cold-air machines, 244
- Wall or plate system of making clear ice, 485, 493-496
 — system, plan for chilling and freezing by circulation of cold brine on, 292, 293
- Walls for cold stores, 350-354
 — of cold stores, radiation of heat through, 287-289
- Washed intestines of freshly killed pigs, experiments with ammonia on, 276
- Washing, cooling, and drying air, apparatus for, 297, 298
- Wastage of ice, 536
- Water, amount of, required in refrigerating apparatus, 570
 — common arrangement for distribution in atmospheric condensers, 157, 158
 — consumption in carbonic acid machines, 142
 — — in sulphuric acid machine, 28, 29
 — — in sulphuric ether machine, 39, 43
 — cooling apparatus, 152-173
 — — towers, 168-173
 — de-aerating or distilling apparatus, 508-517
 — distributing arrangement, 158, 159
 — presence of, in ammonia system, 542
 — saving and cooling apparatus, 168-173
 — specific heat of, 10
- Waterproof coatings for brick surfaces, 345-350
- Waygood & Co., external carcass hoist, 376-378
 — lifts, passenger or goods, 378-380
- Webb's arrangement of suction valves for ammonia compressors, 408
- Weddel & Co., on imports of mutton, lamb, and beef, 2-5
- Wedge, adjustable shoes on crossheads of compressor, 83
 — doors for cold stores, 357-360
- Wegelin and Hübner carbonic acid compression machine, 151
- Well, mercury, for horizontal pipe, 563
 — — vertical pipe, 563, 564
 — sinking, application of refrigeration to, 473
- Westerlin and Campbell double-pipe condenser, 165
- West, H. J., & Co., Ltd., carbonic acid compression machines, 141-144
 — ether compression machine, 118-120
 — submerged condenser, 154
 — *See also* Della Beffa and West
- West India Docks, lifts at, 378
 — Indian fruit, first cargo of, 3
 — Smithfield, lifts at, 378-380
- Wet system of operating ammonia compression machines, 52, 53
- Wetzel pan, water-cooling tower on principle of, 173
- Weyde, Van der, refrigerating machine, 44
 — system of packing ice, 530
- White bleaching of clothes by refrigeration, 472
- Whitehead. *See* Wallis-Taylor and Whitehead
- Whitelaw. *See* Johnson and Whitelaw
- Williamson's cold storage chamber, 293, 294
- Wilson, Thos., Sons, & Co., steamers fitted with refrigerating machinery for the butter trade, 6
- Windhausen apparatus for production of very low temperatures, 593
 — carbonic acid machine, 45, 46, 131
 — cold-air machine, 216-221
 — Franz, compound vacuum pump, 27
 — machine, cost of making ice with, 583, 584
 — — installation of, at Bayswater, 27
- Window insulation, 360
- Windows of cold stores, radiation of heat through, 287
- Wine growers and merchants, use of refrigerating machinery by, 469-471
- Witting gilled piping, 269
- Wolf Co., Fred. W., atmospheric condensers, 161
 — recent design of Linde compressor made by, 81
 — *See also* Pontifex and Wood
- Work, carbonic acid machine, to charge and, 554-556
 — demanded of a machine for effecting mechanical refrigeration, 15-19

- Working, cost of, 579-587
 Wort, beer, cooling of, 444-446
 Worthington water-cooling tower, 170
 Wroblewski, experiments by, in liquefaction of gases, 591
- Y**ARYAN catchalls, modified arrangement of, 547, 548
 — distilling apparatus, 510-517
 — oil separator, 547, 548
 Yeast rooms, brewery, cooling air in, 446, 447
- York Manufacturing Co., compound ammonia compressor, 97-99
 — improved St Clair ammonia compressor, 116
 — single-acting ammonia compressor, 97-99
- Z**ERO on Centigrade thermometrical scale, 12
 — on Fahrenheit thermometrical scale, 12
 — real, 12
 Zschocke water-cooling tower, 171

CROSBY LOCKWOOD & SON'S

LIST OF WORKS

ON

CIVIL, MECHANICAL, MARINE AND ELECTRICAL ENGINEERING.

A Complete Catalogue of NEW and STANDARD WORKS on MINING and COLLIERY WORKING; ARCHITECTURE and BUILDING; The INDUSTRIAL ARTS, TRADES and MANUFACTURES; CHEMISTRY and CHEMICAL MANUFACTURES; AGRICULTURE, FARMING, GARDENING, AUCTIONEERING, LAND AGENCY, &c. Post Free on Application.

LONDON:

7, STATIONERS' HALL COURT, LUDGATE HILL, E.C.

AND

5, Broadway, Westminster, S.W.

1913

CROSBY LOCKWOOD & SONS

LIST OF WORKS

Messrs. **CROSBY LOCKWOOD & SON** beg to announce that they have been appointed Agents for the sale of the series of "**BOOKS FOR HOME STUDY**," issued under the American School of Correspondence, Chicago. These books are both practical and scientific, written by experts whose experience and standing make them authorities on the subjects which they treat. A full descriptive list will be sent post free on application.

LONDON:
11 STATIONERS' HALL COURT, FLEET STREET, E.C. 4.

5, Broadway, Westminster, S.W.

1912

LIST OF WORKS

ON

CIVIL, MECHANICAL, ELECTRICAL AND MARINE ENGINEERING.

- ACETYLENE, LIGHTING BY.** Generators, Burners, and Electric Furnaces. By WILLIAM E. GIBBS, M.E. With 66 Illustrations. Crown 8vo, cloth **7s. 6d.**
- AERIAL NAVIGATION.** A Practical Handbook on the Construction of Dirigible Balloons, Aërostats, Aëroplanes, and Airships. By FREDERICK WALKER, C.E., Associate Member of the Aëronautic Institute. Second Edition, thoroughly revised and enlarged. 176 pages. With 128 Illustrations. Crown 8vo, cloth *Net 5s.*
- AERIAL OR WIRE-ROPE WAYS.** Their Construction and Management. By A. J. WALLIS-TAYLER, A.M.Inst.C.E. 254 pages, with 155 Illustrations. Demy 8vo, cloth *Net 7s. 6d.*
- AERONAUTICS, PRACTICAL.** An understandable Presentation of Interesting and Essential Facts in Aeronautical Science. By CHARLES B. HAYWARD. With Introduction by ORVILLE WRIGHT. 769 pages, Fully Illustrated. Medium 8vo, cloth. [*Just Published. Net 15s.*]
- ALTERNATING CURRENTS, THE PRINCIPLES OF.** For Students of Electrical Engineering. By E. T. LARNER, A.I.E.E., of the Engineering Department, G.P.O., London. 144 pages, with 69 Illustrations. Crown 8vo, cloth. *Net 3s. 6d.*
- ARMATURE WINDINGS OF DIRECT CURRENT DYNAMOS.** Extension and Application of a General Winding Rule. By E. ARNOLD, Engineer, Assistant Professor in Electro-Technics and Machine Design at the Riga Polytechnic School. Translated from the original German by FRANCIS B. DE GRESS, M.E., Chief of Testing Department, Crocker-Wheeler Company. Medium 8vo, 120 pp., with over 140 Illustrations *Net 12s.*
- AVIATION, THE ART OF.** A Handbook upon Aeroplanes and their Engines, with Notes upon Propellers. By ROBERT W. A. BREWER, A.M.I.C.E., M.I.M.E., Fellow of the Society of Engineers (Gold Medallist), Member of the Institution of Automobile Engineers, author of "The Motor Car," Recently Manager to Mr. Grahame-White. Popular Edition. Demy 8vo, cloth, 294 pages, with Illustrations and Dimensioned Drawings [*Just Published. Net 5s.*]
- AVIATION POCKET BOOK FOR 1913.** Containing the Theory and Design of the Aeroplane, Structural Material, Examples of Actual Machines, Meteorological Data, Military Information and Signalling, &c., &c. By R. BORLASE MATTHEWS, A.M.I.C.E., M.I.E.E., Member of the Aero Club. 180 pages, Fully Illustrated. Fcap. 8vo. [*Just Published. Net 3s. 6d.*]
- AVIATION.** See also FLYING MACHINES.
- BALLOONS — MODEL BALLOONS AND FLYING MACHINES,** with a Short Account of the Progress of Aviation. By J. H. ALEXANDER, M.B., A.I.E.E., Associate of the Scottish Aeronautical Society. 136 pages, with 46 Illustrations, and five sheets of Working Drawings. Crown 8vo, cloth *Net 3s. 6d.*

- BEAMS. EXPERIMENTS ON THEIR FLEXURE.** Resulting in the Discovery of New Laws of Failure by Buckling. By ALBERT E. GUY. Medium 8vo, cloth... .. Net 9s.
- BLAST FURNACE CALCULATIONS AND TABLES FOR FURNACE MANAGERS AND ENGINEERS.** Containing Rules and Formulæ for Finding the Dimensions and Output Capacity of any Furnace, as well as the regular Outfit of Stoves, Heating Surface, Volume of Air, Tuyère Area, &c., per ton of Iron per day of 24 hours. By JOHN L. STEVENSON. Fcap. 8vo, leather Net 5s.
- BOILER AND FACTORY CHIMNEYS.** Their Draught-Power and Stability. With a chapter on "Lightning Conductors." By ROBERT WILSON, A.I.C.E., author of "A Treatise on Steam Boilers," etc. Crown 8vo, cloth 3s. 6d.
- BOILER CONSTRUCTION.** A Practical Handbook for Engineers, Boiler-Makers, and Steam Users. Containing a large Collection of Rules and Data relating to Recent Practice in the Design, Construction, and Working of all Kinds of Stationary, Locomotive, and Marine Steam-Boilers. By WALTER S. HUTTON, Civil and Mechanical Engineer. With upwards of 500 Illustrations. Fourth Edition, carefully Revised and Enlarged. Medium 8vo, over 680 pages, cloth, strongly bound 18s.
- HEAT, RADIATION, AND CONDUCTION—NON-CONDUCTING MATERIALS AND COVERINGS FOR STEAM-BOILERS—COMPOSITION, CALORIFIC-POWER AND EVAPORATIVE-POWER OF FUELS—COMBUSTION, FIRING STEAM-BOILERS, PRODUCTS OF COMBUSTION, ETC.—CHIMNEYS FOR STEAM-BOILERS—STEAM-BLAST—FORCED-DRAUGHT—FEED-WATER—EFFECT OF HEAT ON WATER—EXPANSION OF WATER BY HEAT—WEIGHT OF WATER AT DIFFERENT TEMPERATURES—CONVECTION—CIRCULATION—EVAPORATION—PROPERTIES OF SATURATED STEAM—EVAPORATIVE POWER OF BOILERS—PRIMING, ETC.—WATER-HEATING-SURFACES OF STEAM-BOILERS—TRANSMISSION OF HEAT—SMOKE-TUBES—EVAPORATIVE POWER AND EFFICIENCY OF BOILERS—WATER-CAPACITY AND STEAM-CAPACITY OF BOILERS—FIRE-GRATES, FIRE-BRIDGES, AND FIRE-BARS—POWER OF BOILERS—CYLINDRICAL SHELLS AND FURNACE-TUBES OF BOILERS, ETC.—TESTS OF MATERIALS—STRENGTH AND WEIGHT OF BOILER-PLATES—EFFECT OF TEMPERATURE ON METALS—RIVET-HOLES—RIVETS—RIVETED-JOINTS OF STEAM-BOILERS—CAULKING—ENDS OF CYLINDRICAL SHELLS—STAYS FOR BOILERS, ETC.—STEAM-GENERATORS—DESCRIPTION AND PROPORTIONS OF CORNISH, LANCASHIRE, AND OTHER TYPES OF STATIONARY BOILERS—BOILER-SETTING—MULTI-TUBULAR, LOCOMOTIVE, PORTABLE, MARINE, VERTICAL, AND WATER-TUBE BOILERS—SUPER-HEATERS—COST OF STEAM PRODUCTION—FURNACES FOR REFUSE-FUELS—DESTRUCTORS, ETC.—SAFETY-VALVES—STEAM-PIPES—STOP-VALVES AND OTHER MOUNTINGS FOR BOILERS—FEED-PUMPS—STEAM-PUMPS—FEED-WATER CONSUMPTION—INJECTORS—INCRUSTATION AND CORROSION—FEED-WATER HEATERS—EVAPORATORS—TESTING BOILERS—EVAPORATIVE PERFORMANCES OF STEAM BOILERS: STEAM-BOILER EXPLOSIONS, ETC.
- BOILERMAKER'S ASSISTANT.** In Drawing, Templating, and Calculating Boiler Work, etc. By J. COURTNEY, Practical Boiler-Maker. Edited by D. K. CLARK, C.E. Eighth Edition. Crown 8vo, cloth 2s.
- BOILERMAKER'S READY RECKONER.** With Examples of Practical Geometry and Templating for the Use of Platers, Smiths, and Riveters. By JOHN COURTNEY. Edited by D. K. CLARK, M.Inst.C.E. Crown 8vo, cloth 4s.
- BOILERMAKER'S READY RECKONER AND ASSISTANT,** being the two previous mentioned volumes bound together in one volume. With Examples of Practical Geometry and Templating for the Use of Platers, Smiths, and Riveters. By JOHN COURTNEY, Edited by D. K. CLARK, M.Inst.C.E. Fifth Edition, 480 pp., with 140 Illustrations. Crown 8vo, half bound 7s.

- BOILER MAKING AND PLATING.** A Practical Handbook for Workshop Operations, including an Appendix of Tables. By JOSEPH G. HORNER, A.M.I.M.E. Second Edition thoroughly Revised and Enlarged. 380 pp. with 351 Illustrations. Large Crown 8vo, cloth. *Net 9s.*
- BOILERS (STEAM).** Their Construction and Management. By R. ARMSTRONG, C.E. Illustrated. Crown 8vo, cloth ... *1s. 6d.*
- BOILERS.** Their Strength, Construction, and Economical Working. By R. WILSON, C.E. Fifth Edition. 12mo, cloth ... *6s.*
- BOILERS—MODERN STEAM BOILERS: THE LAN-CASHIRE BOILER.** A Practical Manual for Owners and Users of Steam Boilers generally. By W. D. WANSBROUGH, Author of "The Portable Steam Engine." 186 pp. with 117 Illustrations. Demy 8vo, cloth. [*Just Published. Net 4s. 6d.*]
- BRIDGE CONSTRUCTION IN CAST AND WROUGHT IRON.** A Complete and Practical Treatise on, including Iron Foundations. In Three Parts.—Theoretical, Practical, and Descriptive. By WILLIAM HUMBER, A.M.Inst.C.E., and M.Inst.M.E. Third Edition, revised and much improved, with 115 Double Plates (20 of which now first appear in this edition), and numerous Additions to the Text. In 2 vols., imp. 4to, half-bound in morocco ... *Net £6 16s. 6d.*
- BRIDGES AND VIADUCTS, IRON AND STEEL.** A Practical Treatise upon their Construction. For the Use of Engineers, Draughtsmen, and Students. By FRANCIS CAMPIN, C.E. Crown 8vo, cloth ... *3s. 6d.*
- BRIDGES (IRON) OF MODERATE SPAN:** Their Construction and Erection. By H. W. PENDRED. With 40 illustrations Crown 8vo, cloth ... *2s.*
- BRIDGES, OBLIQUE.** A Practical and Theoretical Essay. With 13 large Plates. By the late GEORGE WATSON BUCK, M.Inst.C.E. Fourth Edition, revised by his Son, J. H. WATSON BUCK, M.Inst.C.E.; and with the addition of Description to Diagrams for Facilitating the Construction of Oblique Bridges, by W. H. Barlow, M.Inst.C.E. Royal 8vo, cloth ... *12s.*
- BRIDGES, TUBULAR AND OTHER IRON GIRDER.** Describing the Britannia and Conway Tubular Bridges. With a Sketch of Iron Bridges, Etc. By G. D. DEMPSEY, C.E. Crown 8vo, cloth *2s.*
- CALCULATOR (NUMBER, WEIGHT AND FRACTIONAL).** Containing upwards of 250,000 Separate Calculations, showing at a Glance the Value at 422 Different Rates, ranging from $\frac{1}{125}$ th of a Penny to 20s. each, or per cwt., and £20 per ton, of any number of articles consecutively, from 1 to 470. Any number of cwts., qrs., and lbs., from 1 cwt. to 470 cwts. Any number of tons, cwts., qrs., and lbs., from 1 to 1,000 tons. By WILLIAM CHADWICK, Public Accountant. Fifth Edition, Revised and Improved. 8vo, strongly bound ... *18s.*
- CALCULATOR (WEIGHT).** Being a Series of Tables upon a New and Comprehensive Plan, exhibiting at one Reference the exact Value of any Weight from 1 lb. to 15 tons, at 300 Progressive Rates, from 1*d.* to 168*s.* per cwt., and containing 186,000 Direct Answers, which, with their Combinations, consisting of a single addition (mostly to be performed at sight), will afford an aggregate of 10,266,000 Answers; the whole being calculated and designed to ensure correctness and promote despatch. By HENRY HARBEN, Accountant. Sixth Edition, carefully Corrected. Royal 8vo strongly half-bound ... *£1 5s.*

- CARBURATION: IN THEORY AND PRACTICE.** including a Criticism of Carburation Development. A Manual of Reference for Automobile Engineers and Owners. By ROBERT W. A. BREWER, A.M.Inst.C.E., Author of "Motor Car Construction." With numerous Illustrations, Tables, and Diagrams. *[In Preparation. Price about 8s. 6d. net.]*
- CHAIN CABLES AND CHAINS.** Comprising Sizes and Curves of Links, Studs, Etc., Iron for Cables and Chains, Chain Cable and Chain Making, Forming and Welding Links, Strength of Cables and Chains, Certificates for Cables, Marking Cables, Prices of Chain Cables and Chains, Etc., Etc. By THOMAS W. TRAILL, F.E.R.N., M.Inst.C.E., Engineer-Surveyor-in-Chief, Board of Trade, etc. With numerous Tables, Illustrations, and Lithographic Drawings. Folio, cloth ... **£2 2s.**
- CIVIL ENGINEERING.** By HENRY LAW, M.Inst.C.E. Including a Treatise on Hydraulic Engineering by G. R. BURNELL, M.Inst.C.E. Seventh Edition, Revised, with Large Additions on Recent Practice by D. KINNEAR CLARK, M.Inst.C.E. Crown 8vo, cloth ... **6s. 6d.**
- COKE—MODERN COKING PRACTICE.** Including the Analysis of Materials and Products. A handbook for those engaged or interested in Coke Manufacture with recovery of Bye-Products. By T. H. BYROM, F.I.C., F.C.S., Mem. Soc. Chem. Industry; Chief Chemist to the Wigan Coal and Iron Co.; Author of "The Physics and Chemistry of Mining"; and J. E. CHRISTOPHER, Mem. Soc. Chem. Industry. 168 pp., with numerous Illustrations. Demy 8vo, cloth. *Net 8s. 6d.*
- COMPRESSED AIR WORK AND DIVING.** A Handbook for Engineers, comprising Deep Water Diving and the use of Compressed Air for Sinking Caissons and Cylinders and for Driving Subaqueous Tunnels. By G. W. M. BOYCOTT, Assoc.M.Inst.C.E. With numerous Plates and other Illustrations. Medium 8vo, cloth. ... *Net 10s. 6d.*
- STAGE DECOMPRESSION—THE COMMON DIVING DRESS AND HELMET—ROUQUAYROL-DENAYROUZE APPARATUS—FLEUSS DRESS—THE DIVING BELL—PUMPS—PNEUMATIC CAISSONS AND CYLINDERS—TUNNELLING—BLACKWALL AND ROTHERHITHE TUNNELS—EAST RIVER TUNNELS, NEW YORK—ROCK BLASTING—AIR COMPRESSORS.
- CONTINUOUS RAILWAY BRAKES.** A Practical Treatise on the several Systems in Use in the United Kingdom, their Construction and Performance. By M. REYNOLDS. 8vo, cloth ... **9s.**
- CRANES,** the Construction of, and other Machinery for Raising Heavy Bodies for the Erection of Buildings, Etc. By J. GLYNN, F.R.S. Crown 8vo, cloth ... **1s. 6d.**
- CURVES. TABLES OF TANGENTIAL ANGLES AND MULTIPLES.** For Setting-out Curves from 5 to 200 Radius. By A. BEAZELEY, M.Inst.C.E. Seventh Edition, Revised. With an Appendix on the use of the Tables for Measuring up Curves. Printed on 50 Cards, and sold in a cloth box, waistcoat-pocket size... **3s. 6d.**
- DIESEL OR SLOW-COMBUSTION OIL ENGINE.** A Practical Treatise on the Design and Construction of the Diesel Engine for the Use of Draughtsmen, Students, and others. By G. JAMES WELLS, Wh.Sc., A.M.Inst.C.E., M.I.Mech.E., and A. J. WALLIS-TAYLER, C.E., A.M.Inst.C.E., Author of "Refrigeration, Cold Storage, and Ice-Making," &c. *[In Preparation.]*
- DRAINAGE OF LANDS, TOWNS AND BUILDINGS.** By G. D. DEMPSEY, C.E. Revised, with Large Additions on Recent Practice in Drainage Engineering by D. KINNEAR CLARK, M.Inst.C.E. Fourth Edition. Crown 8vo, cloth ... **4s. 6d.**

- DREDGES AND DREDGING.** By CHARLES PRELINI, Author of "Earth and Rock Excavation," "Tunnelling," &c. 290 pp., with 82 Illustrations. Royal 8vo, cloth *Net 12s. 6d.*
- DRYING MACHINERY AND PRACTICE.** A Handbook on the Theory and Practice of Drying and Desiccating, with Classified Description of Installations, Machinery, and Apparatus, including also a Glossary of Technical Terms and Bibliography. By THOMAS G. MARLOW, Grinding, Drying, and Separating Machinery Specialist. 346 pages, with 174 Illustrations, and numerous tables. Medium 8vo, cloth *Net 12s. 6d.*
- DYNAMIC ELECTRICITY AND MAGNETISM, ELEMENTS OF.** A Handbook for Students and Electrical Engineers. By PHILIP ATKINSON, A.M., Ph.D. Crown 8vo, cloth, 417 pp., with 120 Illustrations *10s. 6d.*
- DYNAMO BUILDING. HOW TO MAKE A DYNAMO.** A Practical Treatise for Amateurs. By A. CROFTS. Crown 8vo, cloth. *2s.*
- DYNAMO ELECTRIC MACHINERY.** Its Construction, Design and Operation. In Two Volumes (Sold separately).
 Vol. I.—**DIRECT CURRENT MACHINES.** By SAMUEL SHELDON, A.M., Ph.D., and ERICH HAUSMANN, B.S., E.E. Eighth Edition, completely rewritten. Large crown 8vo, cloth. 338 pp., 210 Illustrations. *Net 12s.*
 Vol. II.—**ALTERNATING CURRENT MACHINES.** By SAMUEL SHELDON, A.M., Ph.D., and HOBART MASON, B.S., E.E., and ERICH HAUSMANN, B.S., E.E. Eighth Edition, Completely Rewritten. Large crown 8vo, cloth. 366 pp., with 236 Illustrations *Net 12s.*
- DYNAMO MANAGEMENT.** A Handybook of Theory and Practice. For the use of Mechanics, Engineers, Students, and others in charge of Dynamos. By G. W. LUMMIS-PATERSON, Electrical Engineer. Fourth Edition, Revised and Enlarged. 300 pp., with 117 Illustrations. Crown 8vo, cloth *Net 4s. 6d.*
- DYNAMO, MOTOR, AND SWITCHBOARD CIRCUITS FOR ELECTRICAL ENGINEERS.** A Practical Book dealing with the subject of Direct, Alternating, and Polyphase Currents. By WM. R. BOWKER, Consulting Electrical and Street Railway Engineer, Prof. of Physics in the University of Southern California. Second Edition, Revised. Medium 8vo, cloth. With Diagrams... *Net 7s. 6d.*
- DYNAMOS (ALTERNATING AND DIRECT CURRENT).** A Text-book on their Construction for Students, Engineer-Constructors and Electricians-in-Charge. By TYSON SEWELL, A.M.I.E.E., Lecturer and Demonstrator in Electrical Engineering at the Polytechnic, Regent Street. 328 pp., with over 230 Illustrations. Large crown 8vo, cloth *Net 7s. 6d.*
- EARTHWORK DIAGRAMS.** These Diagrams or Scales have been designed with the intention of reducing the labour connected with the computation of earthwork quantities, and especially those of railways and roads. By R. A. ERSKINE-MURRAY, A.M.Inst.C.E., and Y. D. KIRTON, A.M.Can.Soc.C.E. On a sheet in a roll, *net 5s.*, or mounted on card, *net 7s. 6d.*
- EARTHWORK MANUAL.** By ALEX. J. GRAHAM, C.E. With numerous Diagrams. Second Edition. 18mo, cloth *2s. 6d.*

- EARTHWORK TABLES.** Showing the Contents in Cubic Yards of Embankments, Cuttings, &c., of Heights or Depths up to an average of 80 feet. By JOSEPH BROADBENT, C.E., and FRANCIS CAMPIN, C.E. Crown 8vo, cloth 5s.
- EARTHWORK TABLES, HANDY GENERAL.** Giving the Contents in Cubic Yards of Centre and Slopes of Cuttings and Embankments from 3 inches to 80 feet in Depth or Height, for use with either 66 feet Chain or 100 feet Chain. By J. H. WATSON BUCK, M.Inst.C.E. On a Sheet mounted in cloth case 3s. 6d.
- ELECTRIC LIGHT.** Its Production and Use. By J. W. URQUHART. Crown 8vo, cloth 7s. 6d.
- ELECTRIC LIGHT FITTING.** A Handbook for Working Electrical Engineers. By J. W. URQUHART. Crown 8vo, cloth 5s.
- ELECTRIC LIGHT FOR COUNTRY HOUSES.** A Practical Handbook, including Particulars of the Cost of Plant and Working. By J. H. KNIGHT. Crown 8vo, wrapper 1s.
- ELECTRIC LIGHTING.** By ALAN A. CAMPBELL SWINTON, M.Inst.C.E., M.I.E.E. Crown 8vo, cloth 1s. 6d.
- ELECTRIC LIGHTING AND HEATING. A POCKET-BOOK.** Comprising useful Formulæ, Tables, Data, and Particulars of Apparatus and Appliances for the Use of Central Station Engineers, Contractors, and Engineers-in-Charge. By SYDNEY F. WALKER, R.N., M.I.E.E., M.I.M.E., A.M.Inst.C.E., Etc. Fcap. 8vo, 448 pp., 270 Diagrams, and 240 Tables Net 7s. 6d.
- ELECTRIC MOTORS; THEIR ACTION, CONTROL, AND APPLICATION.** By FRANCIS B. CROCKER, E.M., Ph.D., Professor of Electrical Engineering, Columbia University; Past Pres. A.I.E.E.; Mem. British Inst. E.E.; and M. ARENDT, E.E., Assistant Professor of Electrical Engineering, Columbia University; Mem. A.I.E.E. 297 pages, 158 Illustrations. Medium 8vo, cloth Net 10s. 6d.
- ELECTRIC POWER CONDUCTORS.** By WM. A. DEL MAR, A.C.G.I., Assoc. Mem. A.I.E.E., Assoc. I.E.E. Large crown 8vo, cloth. 336 pages, with numerous illustrations. Net 9s.
- MATERIALS AND GAUGES—TESTING WIRE AND CABLE—ELECTRICAL PROPERTIES—INSTALLATION—INSULATION AND INSULATED CONDUCTORS—DEPRECIATION AND DETERIORATION—DETERMINATION OF SIZE FOR GIVEN VOLTAGE DROP AND POWER LOSS—THIRD RAIL CIRCUITS—DETERMINATION OF SIZE FOR GIVEN STRESS IN SPANS—RAIL BONDS—SPECIFICATIONS—TABLES OF INDUCTANCE, REACTANCE, AND CAPACITY, &c.
- ELECTRIC POWER CONDUCTORS;—CONDUCTORS FOR ELECTRICAL DISTRIBUTION,** their Materials and Manufacture. The Calculation of Circuits, Pole-line Construction, Underground Working, and other Uses. By F. A. C. PERRINE, A.M., D.Sc., Mem.Am.Inst.E.E. Second Edition, Revised. Medium 8vo, 300 pp., fully illustrated Net 15s.
- ELECTRIC SHIP-LIGHTING.** A Handbook on the Practical Fitting and Running of Ship's Electrical Plant. By J. W. URQUHART. Fourth Edition, Revised and Enlarged. 365 pages, with 90 Illustrations. Crown 8vo, cloth 7s. 6d.
- ELECTRIC TRACTION AND TRANSMISSION ENGINEERING.** By SAMUEL SHELDON, A.M., Ph.D., D.Sc., and ERICH HAUSMANN, E.E., M.S. 317 pp., 127 Illustrations. Large crown 8vo, cloth [Just Published. Net 12s.
- ELECTRIC WIRING, DIAGRAMS AND SWITCH-BOARDS.** By NEWTON HARRISON, E.E., Instructor of Electrical Engineering in the Newark Technical School. Crown 8vo, cloth. Net 5s.

ELECTRIC WIRING, &c.—continued.

THE BEGINNING OF WIRING—CALCULATING THE SIZE OF WIRE—A SIMPLE ELECTRIC LIGHT CIRCUIT CALCULATED—ESTIMATING THE MAINS, FEEDERS, AND BRANCHES—USING THE BRIDGE FOR TESTING—THE INSULATION RESISTANCE—WIRING FOR MOTORS—WIRING WITH CLEATS, MOULDING AND CONDUIT—LAYING-OUT A CONDUIT SYSTEM—POWER REQUIRED FOR LAMPS—LIGHTING OF A ROOM—SWITCHBOARDS AND THEIR PURPOSE—SWITCHBOARDS DESIGNED FOR SHUNT AND COMPOUND-WOUND DYNAMOS—PANEL SWITCHBOARDS, STREET RAILWAY SWITCHBOARDS, LIGHTNING ARRESTERS—THE GROUND DETECTOR—LOCATING GROUNDS—ALTERNATING CURRENT CIRCUITS—THE POWER FACTOR IN CIRCUITS—CALCULATION OF SIZES OF WIRE FOR SINGLE, TWO AND THREE-PHASE CIRCUITS.

ELECTRICAL AND MAGNETIC CALCULATIONS.

For the use of Electrical Engineers and Artisans, Teachers, Students, and all others interested in the Theory and Application of Electricity and Magnetism. By A. A. ATKINSON, M.S., Professor of Physics and Electricity in Ohio University, Athens, Ohio. Crown 8vo, cloth *Net 9s.*

ELECTRICAL CALCULATIONS (ELEMENTARY).

A Manual of Simple Engineering Mathematics, covering the whole field of Direct Current Calculations, the Basis of Alternating Current Mathematics, Networks and Typical Cases of Circuits, with Appendices on Special Subjects. By T. O'CONNOR SLOANE, A.M., E.M., Ph.D., Author of "The Standard Electrical Dictionary." Large Crown 8vo, cloth, 314 pp. with Diagrams *Net 9s.*

ELECTRICAL DICTIONARY.

A Popular Encyclopædia of Words and Terms used in the Practice of Electrical Engineering. By T. O'CONNOR SLOANE, A.M., E.M., Ph.D. Fourth Edition, with Appendix. 690 pages and nearly 400 Illustrations. Large Crown 8vo, cloth *Net 7s. 6d.*

ELECTRICAL ENGINEERING.

A First-Year's Course for Students. By TYSON SEWELL, A.M.I.E.E., Lecturer and Demonstrator in Electrical Engineering at the Polytechnic, Regent Street, London. Fifth Edition, Thoroughly Revised. Large Crown 8vo, cloth. 465 pp., with 277 Illustrations *Net 5s.*

OHM'S LAW—UNITS EMPLOYED IN ELECTRICAL ENGINEERING—SERIES AND PARALLEL CIRCUITS—CURRENT DENSITY AND POTENTIAL DROP IN THE CIRCUIT—THE HEATING EFFECT OF THE ELECTRIC CURRENT—THE MAGNETIC EFFECT OF AN ELECTRIC CURRENT—THE MAGNETISATION OF IRON—ELECTRO CHEMISTRY—PRIMARY BATTERIES—ACCUMULATORS—INDICATING INSTRUMENTS—AMMETERS, VOLTMETERS, OHMMETERS—ELECTRICITY SUPPLY METERS—MEASURING INSTRUMENTS, AND THE MEASUREMENT OF ELECTRICAL RESISTANCE—MEASUREMENT OF POTENTIAL DIFFERENCE, CAPACITY, CURRENT STRENGTH, AND PERMEABILITY—ARC LAMPS—INCANDESCENT LAMPS—MANUFACTURE AND INSTALLATION—PHOTOMETRY—THE CONTINUOUS CURRENT DYNAMO—DIRECT CURRENT MOTORS—ALTERNATING CURRENTS—TRANSFORMERS, ALTERNATORS, SYNCHRONOUS MOTORS—POLYPHASE WORKING—APPENDIX I., THE THREE WIRE SYSTEM—APPENDIX II., QUESTIONS AND ANSWERS.

ELECTRICAL ENGINEERING (ELEMENTARY).

In Theory and Practice. A Class Book for Junior and Senior Students and Working Electricians. By J. H. ALEXANDER. With nearly 200 Illustrations. Crown 8vo, cloth *Net 3s. 6d.*

FUNDAMENTAL PRINCIPLES—ELECTRICAL CURRENTS—SOLENOID COILS, GALVANOMETERS, VOLT-METERS—MEASURING INSTRUMENTS—ALTERNATING CURRENTS—DYNAMO ELECTRIC MACHINES—CONTINUOUS CURRENT DYNAMOS—INDUCTION, STATIC TRANSFORMERS, CONVERTERS—MOTORS—PRIMARY AND STORAGE CELLS—ARC LAMPS—INCANDESCENT LAMPS—SWITCHES, FUSES, ETC.—CONDUCTORS AND CABLES—ELECTRICAL ENERGY METERS—SPECIFICATIONS—GENERATION AND TRANSMISSION OF ELECTRICAL ENERGY—GENERATING STATIONS.

ELECTRICAL ENGINEERING, GENERAL LECTURES

ON. By C. PROTEUS STEINMETZ, A.M., Ph.D. Third edition, compiled and edited by J. LEROY HAYDEN. 284 pages, with Diagrams. Medium 8vo, cloth *Net 8s. 6d.*

ELECTRICAL ENGINEERING. See ALTERNATING CURRENTS.

ELECTRICAL TRANSMISSION OF ENERGY. A

Manual for the Design of Electrical Circuits. By ARTHUR VAUGHAN ABBOTT, C.E., Member American Institute of Electrical Engineers, etc. Fifth Edition, Rewritten and Enlarged, with numerous Tables, Plates, and other Illustrations. Royal 8vo, 700 pages. Strongly bound in cloth Net 21s.

ELECTRICAL TRANSMISSION OF ENERGY—THREE PHASE TRANSMISSION.

A Practical Treatise on the Economic Conditions governing the Transmission of Electric Energy by Underground and Overhead Conductors. By WILLIAM BREW, M.I.E.E., Late Chief Expert Assistant, Dublin Corporation Electricity Supply. 186 pp., with 83 Illustrations. Demy 8vo, cloth Net 7s. 6d.

ELECTRICITY AS APPLIED TO MINING.

By ARNOLD LUPTON, M.Inst.C.E., M.I.Mech.E., M.I.E.E., late Professor of Coal Mining at the Yorkshire College, Victoria University; G. D. ASPINALL PARR, M.I.E.E., A.M.I.Mech.E., Head of the Electrical Engineering Department, Yorkshire College, Victoria University; and HERBERT PERKIN, M.I.M.E., Assistant Lecturer in the Mining Department of the Yorkshire College, Victoria University. Second Edition, Revised and Enlarged, medium 8vo, cloth, 300 pp., with about 170 Illustrations. Net 12s.

INTRODUCTORY—DYNAMIC ELECTRICITY—DRIVING OF THE DYNAMO—THE STEAM TURBINE—DISTRIBUTION OF ELECTRICAL ENERGY—STARTING AND STOPPING ELECTRICAL GENERATORS AND MOTORS—ELECTRIC CABLES—CENTRAL ELECTRICAL PLANTS—ELECTRICITY APPLIED TO PUMPING AND HAULING—ELECTRICITY APPLIED TO COAL CUTTING—TYPICAL ELECTRIC PLANTS RECENTLY ERECTED—ELECTRIC LIGHTING BY ARC AND GLOW LAMPS—MISCELLANEOUS APPLICATIONS OF ELECTRICITY—ELECTRICITY AS COMPARED WITH OTHER MODES OF TRANSMITTING POWER—DANGERS OF ELECTRICITY.

ELECTRICITY IN FACTORIES AND WORKSHOPS :

ITS COST AND CONVENIENCE. A Handybook for Power Producers and Power Users. By A. P. HASLAM, M.I.E.E. 328 pp., with numerous Illustrations. Large crown 8vo, cloth. Net 7s. 6d.

THE ELECTRIC MOTOR AND ITS ACCESSORIES—THE DIRECT CURRENT MOTOR—THE ALTERNATING CURRENT MOTOR—THE STARTING AND SPEED REGULATION OF ELECTRIC MOTORS—THE RATING AND EFFICIENCY OF ELECTRIC MOTORS—THE PROVISION OF ELECTRIC ENERGY—THE COST OF ENERGY AS AFFECTED BY CONDITIONS OF WORKING—THE QUESTION FOR THE SMALL POWER USER—INDEPENDENT GENERATING PLANTS—OIL AND GAS ENGINE PLANTS—INDEPENDENT GENERATING PLANTS—STEAM PLANTS—POWER STATION TARIFFS—THE APPLICATIONS OF ELECTRIC POWER—THE USE OF ELECTRIC POWER IN TEXTILE FACTORIES—ELECTRIC POWER IN PRINTING WORKS—THE USE OF ELECTRIC POWER IN ENGINEERING WORKSHOPS—MISCELLANEOUS APPLICATIONS OF ELECTRIC POWER—THE INSTALLATION OF ELECTRIC MOTORS—THE LIGHTING OF INDUSTRIAL ESTABLISHMENTS.

ELECTRICITY. A STUDENT'S TEXT-BOOK.

By H. M. NOAD, F.R.S. 650 pp., 470 illustrations. Crown 8vo ... 9s.

ELECTRICITY, POWER TRANSMITTED BY, AND

APPLIED BY THE ELECTRIC MOTOR, including Electric Railway Construction. By PHILIP ATKINSON, A.M., Ph.D., author of "Elements of Static Electricity." Fourth Edition, Enlarged, Crown 8vo, cloth, 224 pp., with over 90 illustrations Net 9s.

ELECTRO-PLATING AND ELECTRO-REFINING OF

METALS. Being a new edition of Alexander Watt's "Electro-Deposition." Revised and Largely Re-written by ARNOLD PHILIP, Assoc. R.S.M., B.Sc., A.I.E.E., F.I.C., Principal Assistant to the Admiralty Chemist, formerly Chief Chemist to the Engineering Departments of the India Office. Second Edition, Revised. 700 pp., with numerous Illustrations, Large Cr. 8vo, cloth Net 12s. 6d.

ENGINEERING DRAWING. A WORKMAN'S MANUAL. By JOHN MAXTON. Crown 8vo, cloth ... 3s. 6d

ENGINEERING ESTIMATES, COSTS, & ACCOUNTS. A Guide to Commercial Engineering. With numerous examples of Estimates and Costs of Millwright Work, Miscellaneous Productions, Steam Engines and Steam Boilers; and a Section on the Preparation of Costs Accounts. By A GENERAL MANAGER. Third Edition. Revised and Corrected. 276 pages. 8vo, cloth Net 7s. 6d.

ENGINEERING PROGRESS (1863-6). By WM. HUMBER, A.M.Inst.C.E. Complete in Four Vols. Containing 148 Double Plates, with Portraits and Descriptive Letterpress. Imperial 4to, half morocco. Price, complete, £12 12s.; or sold separately at £3 3s. per Volume.

ENGINEER'S AND MILLWRIGHT'S ASSISTANT. A Collection of Useful Tables, Rules, and Data. By WILLIAM TEMPLETON. Eighth Edition, with Additions. 18mo, cloth... .. 2s. 6d.

ENGINEER'S HANDBOOK. A Practical Treatise on Modern Engines and Boilers, Marine, Locomotive, and Stationary. And containing a large collection of Rules and Practical Data relating to Recent Practice in Designing and Constructing all kinds of Engines, Boilers, and other Engineering work. The whole constituting a comprehensive Key to the Board of Trade and other Examinations for Certificates of Competency in Modern Mechanical Engineering. By WALTER S. HUTTON, Civil and Mechanical Engineer, Author of "The Works' Manager's Handbook for Engineers," etc. Seventh Edition, Revised and Enlarged. 576 pp., with 430 Illustrations. Med. 8vo, cloth 18s.

ENGINEER'S, MECHANIC'S, ARCHITECT'S, BUILDER'S, ETC., TABLES AND MEMORANDA. Selected and Arranged by FRANCIS SMITH. Seventh Edition, Revised, including ELECTRICAL TABLES, FORMULÆ, and MEMORANDA. Waistcoat-pocket size, limp leather 1s. 6d.

ENGINEER'S POCKET BOOK. See MECHANICAL ENGINEER'S POCKET BOOK.

ENGINEER'S YEAR-BOOK FOR 1913. Comprising Formulæ, Rules, Tables, Data and Memoranda. Forming a Compendium of the Modern Practice of Civil, Mechanical, Electrical, Marine, Gas, and Mine Engineering. By H. R. KEMPE, M.Inst.C.E., M.I.Mech.E., M.I.E.E., Electrician to the Post Office (1907-1912), formerly Principal Staff Engineer, Engineer-in-Chief's Office, General Post Office, London, With the collaboration of eminent specialists. 1,600 pages. With 1,250 Illustrations, specially Engraved for the work. Crown 8vo, leather.

[Just Published. 12s. 6d.]

LIST OF SPECIALIST CONTRIBUTORS:—W. VALENTINE BALL, M.A., Barrister-at-Law (Legal Notes for Engineers); WM. H. BOOTH, C.E., F.G.S., M.Am.Soc.C.E. (Steam Engines and Boilers, Fuels, Pumps, Cotton Mills, Cranes, Water Softening, Well-Sinking, &c.); G. A. BURLS, M.Inst.C.E. (Internal Combustion Engines, Motor Cars, and Aeroplanes); Prof. C. A. CARUS-WILSON, M.A., M.I.E.E., A.M.Inst.C.E. (Electrical Engineering); A. B. CHALKLEY, B.Sc., A.M.Inst.C.E. (Marine Diesel Engines); BRYSSON CUNNINGHAM, B.E., A.M.Inst.C.E. (Harbour and Dock Engineering); ALEX. DREW, M.I.Mech.E., M.C.I. (Reinforced Concrete Construction); Prof. T. CLAXTON FIDLER, M.Inst.C.E. (Beams, Girders, Bridges, and Joists); H. L. GUY, A.M.Inst.C.E., A.M.I.Mech.E. (Steam Turbines); PERCY A. HILLHOUSE, B.Sc., M.I.N.A. (Naval Architecture and Marine Engineering); W. HOWARD-SMITH, A.M.Inst.C.E. (Tramways, Railways); GEORGE HUGHES, M.I.Mech.E., Chief Mechanical Engineer, Lancashire and Yorkshire Railway (Locomotives); NEWTON B. KNOX, E.M., M.I.M.M. (Metalliferous Mining and Mining Machinery); Prof. VIVIAN B. LEWES, F.I.C., F.C.S., (Acetylene Gas and its Applications); R. FAIRFAX MIDDLETON, A.M.Inst.C.E. (Waterworks Engineer); HENRY O'CONNOR, F.R.S.Edin., A.M.Inst.C.E. (Gas and Gas Works); REGINALD RYVES, A.M.Inst.C.E. (Roads and Streets); E. J. SILCOCK, M.Inst.C.E., F.G.S., F.S.I. (Sewerage, Sewage Disposal, and House Drainage); FRED SIMPSON, A.M.Inst.C.E. (Refrigeration, Ice-Making, and Cold Storage); THE ENGINEERS AND CARRIAGE SUPERINTENDENTS of the principal British Railway Companies (Locomotives and Rolling Stock; Permanent-Way Plant, &c.)

- ENGINEMAN'S POCKET COMPANION**, and Practical Educator for Enginemen, Boiler Attendants, and Mechanics. By MICHAEL REYNOLDS. With 45 Illustrations and numerous Diagrams. Fifth Edition. Royal 18mo, strongly bound for pocket wear **3s. 6d.**
- EXCAVATION (EARTH AND ROCK)**. A Practical Treatise, by CHARLES PRELINI, C.E. 365 pp., with Tables, many Diagrams and Engravings. Royal 8vo, cloth **Net 16s.**
- FACTORY ACCOUNTS**. Their Principles and Practice. A Handbook for Accountants and Manufacturers. By E. GARCKE and J. M. FELS. Sixth Edition, Revised and considerably extended. 314 pages. Demy 8vo, cloth... .. **Net 6s.**
- FIRE PROTECTION IN BUILDINGS**. A Practical Treatise for Engineers, Architects, Surveyors, and Property Owners. By HAROLD G. HOLT, A.R.I.B.A. 280 pages, with Diagrams and Illustrations. Demy 8vo, cloth. [Just Published. **Net 8s. 6d.**
- FIRES, FIRE-ENGINES, AND FIRE BRIGADES**. With a History of Fire-Engines, their Construction, Use, and Management. Hints on Fire-Brigades, &c. By C. F. T. YOUNG. 8vo, cloth. **£1 4s.**
- FLYING MACHINES OF TO=DAY**. By WM. DUANE ENNIS, Professor of Mechanical Engineering in the Polytechnic Institute of Brooklyn. 218 pages, with 123 Illustrations. Large Crown 8vo, cloth [Just Published. **Net 6s.**
- FLYING MACHINES**. See also AVIATION.
- FOUNDATIONS AND CONCRETE WORKS**. With Practical Remarks on Footings, Planking, Sand and Concrete, Béton, Pile-driving, Caissons, and Cofferdams. By E. DOBSON. Crown 8vo. **1s. 6d.**
- FUEL, ITS COMBUSTION AND ECONOMY**. Consisting of an Abridgment of "A Treatise on the Combustion of Coal and the Prevention of Smoke." By C. W. WILLIAMS, A.Inst.C.E. With extensive Additions by D. KINNEAR CLARK, M.Inst.C.E. Fourth Edition Crown 8vo cloth **3s. 6d.**
- FUELS: SOLID, LIQUID, AND GASEOUS**. Their Analysis and Valuation. For the Use of Chemists and Engineers. By H. J. PHILLIPS, F.C.S., formerly Analytical and Consulting Chemist to the Great Eastern Railway. Fourth Edition. Crown 8vo, cloth. **2s. 0d.**
- GAS AND OIL ENGINE MANAGEMENT**. A Practical Guide for Users and Attendants, being Notes on Selection, Construction and Management. By M. POWIS BALE, M.Inst.C.E., M.I.Mech.E., Author of "Woodworking Machinery," etc. Third Edition, Enlarged. Crown 8vo, cloth **Net 3s. 6d.**
- GAS-ENGINE, A HANDBOOK ON THE**. Comprising a Practical Treatise on Internal Combustion Engines. For the Use of Engine Builders, Engineers, Mechanical Draughtsmen, Engineering Students, Users of Internal Combustion Engines, and others. By HERMAN HAEDER, Civil Engineer, Wiesbaden. Translated from the German, and edited by WILLIAM M. HUSKISSON, A.M.I.E.E. (9½ years with Messrs. Crossley Bros., of Openshaw). With the addition of numerous Useful Tables and other Matter. 330 pages, with over 500 Illustrations and Tables. Small 4to, cloth **Net 18s.**
- "There can be no question as to the utility of the work, and the translator is to be congratulated on the thoroughness with which he has discharged his task."—*Mechanical World*.
- "The work is in every respect of a very high standard, and may be strongly recommended to those who wish to make a study of the technical details of the internal combustion engine."—*Journal of Gas Lighting*.

GAS ENGINEER'S POCKET-BOOK. Comprising Tables, Notes and Memoranda relating to the Manufacture, Distribution, and Use of Coal Gas and the Construction of Gas Works. By H. O'CONNOR, A.M.Inst.C.E. Third Ed., Revised. Crown 8vo, leather *Net 10s. 6d.*

GAS-ENGINE HANDBOOK. A Manual of Useful Information for the Designer and the Engineer. By E. W. ROBERTS, M.E. With Forty Full-page Engravings. Small Fcap. 8vo, leather. *Net 8s. 6d.*

GAS-ENGINES AND PRODUCER-GAS PLANTS. A Treatise setting forth the Principles of Gas Engines and Producer Design, the Selection and Installation of an Engine, the Care of Gas Engines and Producer-Gas Plants, with a Chapter on Volatile Hydrocarbon and Oil Engines. By R. E. MATHOT, M.E. Translated from the French. With a Preface by DUGALD CLERK, M.Inst.C.E., F.C.S. Medium 8vo, cloth, 310 pages, with about 150 Illustrations. *Net 12s.*

MOTIVE POWER AND COST OF INSTALLATION—SELECTION OF AN ENGINE—INSTALLATION OF AN ENGINE—FOUNDATION AND EXHAUST—WATER CIRCULATION—LUBRICATION—CONDITIONS OF PERFECT OPERATION—HOW TO START AN ENGINE—PRECAUTIONS—PERTURBATIONS IN THE OPERATION OF ENGINES—PRODUCER-GAS ENGINES—PRODUCER-GAS—PRESSURE GAS-PRODUCERS—SUCTION GAS-PRODUCERS—OIL AND VOLATILE HYDROCARBON ENGINES—THE SELECTION OF AN ENGINE.

GAS ENGINES. With Appendix describing a Recent Engine with Tube Igniter. By T. M. GOODEVE, M.A. Crown 8vo, cloth. *2s. 6d.*

GAS ENGINES (FARM). By H. R. BRATE. 200 pp., with 36 Illustrations. Crown 8vo, cloth ... [*Just Published. Net 4s. 6d.*]

GAS ENGINES. *See also* INTERNAL COMBUSTION ENGINES.

GAS LIGHTING. *See also* ACETYLENE.

GAS LIGHTING FOR COUNTRY HOUSES. *See* PETROL AIR GAS.

GAS MANUFACTURE, CHEMISTRY OF. A Practical Manual for the Use of Gas Engineers, Gas Managers and Students. By HAROLD M. ROYLE, F.C.S., Chief Chemical Assistant at the Beckton Gas Works. Demy 8vo, cloth. 340 pages, with numerous Illustrations and Coloured Plate *Net 12s. 6d.*

PREPARATION OF STANDARD SOLUTIONS—ANALYSIS OF COALS—DESCRIPTION OF VARIOUS TYPES OF FURNACES—PRODUCTS OF CARBONISATION AT VARIOUS TEMPERATURES—ANALYSIS OF CRUDE GAS—ANALYSIS OF LIME—ANALYSIS OF AMMONIACAL LIQUOR—ANALYTICAL VALUATION OF OXIDE OF IRON—ESTIMATION OF NAPHTHALIN—ANALYSIS OF FIRE-BRICKS AND FIRE-CLAY—ART OF PHOTOMETRY—CARBURETTED WATER GAS—APPENDIX CONTAINING STATUTORY AND OFFICIAL REGULATIONS FOR TESTING GAS, VALUABLE EXCERPTS FROM VARIOUS IMPORTANT PAPERS ON GAS CHEMISTRY, USEFUL TABLES, MEMORANDA, ETC.

GAS WORKS. Their Construction and Arrangement, and the Manufacture and Distribution of Coal Gas. By S. HUGHES, C.E. Ninth Edition. Revised, with Notices of Recent Improvements, by HENRY O'CONNOR, A.M.Inst.C.E. Crown 8vo, cloth *6s.*

GEOMETRY. For the Architect, Engineer, and Mechanic. By E. W. TARN, M.A., Architect. 8vo, cloth *9s.*

GEOMETRY FOR TECHNICAL STUDENTS. By E. H. SPRAGUE, A.M.Inst.C.E. Crown 8vo, cloth *Net 1s.*

GEOMETRY OF COMPASSES. By OLIVER BYRNE. Coloured Plates. Crown 8vo, cloth *3s. 6d.*

GUNNERY. *See* RECOIL OF GUNS.

HEAT, EXPANSION OF STRUCTURES BY. By JOHN KELLY, C.E. Crown 8vo, cloth... .. *3s. 6d.*

HOISTING MACHINERY. Including the Elements of Crane Construction and Descriptions of the Various Types of Cranes in Use. By JOSEPH HORNER, A.M.I.M.E. Crown 8vo, cloth, with 215 Illustrations, including Folding Plates *Net 7s. 6d.*

HYDRAULIC MANUAL. Consisting of Working Tables and Explanatory Text. Intended as a Guide in Hydraulic Calculations and Field Operations. By LOWIS D'A. JACKSON. Fourth Edition, Enlarged. Large Crown 8vo, cloth *16s.*

HYDRAULIC POWER ENGINEERING. A Practical Manual on the Concentration and Transmission of Power by Hydraulic Machinery. By G. CROYDON MARKS, A.M.Inst.C.E. Second Edition, Enlarged, with about 240 Illustrations. 8vo, cloth *Net 10s. 6d.*

SUMMARY OF CONTENTS:—PRINCIPLES OF HYDRAULICS—THE FLOW OF WATER—HYDRAULIC PRESSURES—MATERIAL—TEST LOAD—PACKING FOR SLIDING SURFACES—PIPE JOINTS—CONTROLLING VALVES—PLATFORM LIFTS—WORKSHOP AND FOUNDRY CRANES—WAREHOUSE AND DOCK CRANES—HYDRAULIC ACCUMULATORS—PRESSES FOR BALING AND OTHER PURPOSES—SHEET METAL WORKING AND FORGING MACHINERY—HYDRAULIC RIVETERS—HAND AND POWER PUMPS—STEAM PUMPS—TURBINES—IMPULSE TURBINES—REACTION TURBINES—DESIGN OF TURBINES IN DETAIL—WATER WHEELS—HYDRAULIC ENGINES—RECENT ACHIEVEMENTS—PRESSURE OF WATER—ACTION OF PUMPS, ETC.

INTERNAL COMBUSTION ENGINES. Their Theory, Construction, and Operation. By ROLLA C. CARPENTER, M.M.E., LL.D., and H. DIEDERICHS, M.E., Professors of Experimental Engineering, Sibley College, Cornell University. 610 pages, with 373 Illustrations. Medium 8vo, cloth *Net 21s.*

INTRODUCTION, DEFINITIONS AND CLASSIFICATIONS, INDICATED AND BRAKE HORSE-POWER—THERMODYNAMICS OF THE GAS ENGINE—THEORETICAL COMPARISON OF VARIOUS TYPES OF INTERNAL COMBUSTION ENGINES—THE VARIOUS EVENTS OF THE CONSTANT-VOLUME AND CONSTANT-PRESSURE CYCLE AS MODIFIED BY PRACTICAL CONDITIONS—THE TEMPERATURE ENTROPY DIAGRAM APPLIED TO THE GAS ENGINE—COMBUSTION—GAS-ENGINE FUELS, THE SOLID FUELS, GAS PRODUCERS—THE GAS-ENGINE FUELS, LIQUID FUELS, CARBURETTERS AND VAPORISERS—GAS-ENGINE FUELS, THE GAS FUELS, THE FUEL MIXTURE EXPLOSIBILITY, PRESSURE AND TEMPERATURE—THE HISTORY OF THE GAS ENGINE—MODERN TYPES OF INTERNAL COMBUSTION ENGINES—GAS ENGINE AUXILIARIES, IGNITION, MUFFLERS, AND STARTING APPARATUS—REGULATION OF INTERNAL COMBUSTION ENGINES—THE ESTIMATION OF POWER OF GAS ENGINES—METHODS OF TESTING INTERNAL COMBUSTION ENGINES—THE PERFORMANCE OF GAS ENGINES AND GAS PRODUCERS—COST OF INSTALLATION AND OF OPERATION.

IRON AND METAL TRADES COMPANION. For Expediently Ascertaining the Value of any Goods bought or sold by Weight, from 1s. per cwt. to 112s. per cwt., and from one farthing per pound to one shilling per pound. By THOMAS DOWNIE. Strongly bound in leather, 396 pp. *9s.*

IRON AND STEEL. A Work for the Forge, Foundry, Factory, and Office. Containing ready, useful, and trustworthy Information for Ironmasters and their Stock-takers; Managers of Bar, Rail, Plate, and Sheet Rolling Mills; Iron and Metal Founders; Iron Ship and Bridge Builders; Mechanical, Mining, and Consulting Engineers; Architects, Contractors, Builders, etc. By CHARLES HOARE, Author of "The Slide Rule," etc. Ninth Edition. 32mo, leather *6s.*

IRON AND STEEL CONSTRUCTIONAL WORK, as applied to Public, Private, and Domestic Buildings. By FRANCIS CAMPIN, C.E. Crown 8vo, cloth *3s. 6d.*

IRON AND STEEL GIRDERS. A Graphic Table for Facilitating the Computation of the Weights of Wrought Iron and Steel Girders, etc., for Parliamentary and other Estimates. By J. H. WATSON BUCK, M.Inst.C.E. On a Sheet *2s. 6d.*

IRON-PLATE WEIGHT TABLES. For Iron Shipbuilders, Engineers, and Iron Merchants. Containing the Calculated Weights of upwards of 150,000 different sizes of Iron Plates from 1 ft. by 6 in. by $\frac{1}{4}$ in. to 10 ft. by 5 ft. by 1 in. Worked out on the basis of 40 lbs. to the square foot of Iron 1 in. in thickness. By H. BURLINSON and W. H. SIMPSON. 4to, half-bound £1 5s.

IRRIGATION (PIONEER). A Manual of Information for Farmers in the Colonies. By E. O. MAWSON, M.Inst.C.E., Executive Engineer, Public Works Department, Bombay. With Chapters on Light Railways by E. R. CALTHROP, M.Inst.C.E., M.I.M.E. With Plates and Diagrams. Demy 8vo, cloth Net 10s. 6d.

VALUE OF IRRIGATION, AND SOURCES OF WATER SUPPLY—DAMS AND WEIRS—CANALS—UNDERGROUND WATER—METHODS OF IRRIGATION—SEWAGE IRRIGATION—IMPERIAL AUTOMATIC SLUICE GATES—THE CULTIVATION OF IRRIGATED CROPS, VEGETABLES, AND FRUIT TREES—LIGHT RAILWAYS FOR HEAVY TRAFFIC—USEFUL MEMORANDA AND DATA.

LATHE PRACTICE. A Complete and Practical Work on the Modern American Lathe. By OSCAR E. PERRIGO, M.E., Author of "Modern Machine Shop Construction, Equipment, and Management," etc. Medium 8vo, 424 pp., 315 Illustrations. Cloth Net 12s.

HISTORY OF THE LATHE UP TO THE INTRODUCTION OF SCREW THREADS—ITS DEVELOPMENT SINCE THE INTRODUCTION OF SCREW THREADS—CLASSIFICATION OF LATHES—LATHE DESIGN. THE BED AND ITS SUPPORTS—THE HEAD-STOCK CASTING, THE SPINDLE, AND SPINDLE-CONE—THE SPINDLE BEARINGS, THE BACK GEARS, AND THE TRIPLE-GEAR MECHANISM—THE TAIL STOCK, THE CARRIAGE, THE APRON, ETC.—TURNING RESTS, SUPPORTING RESTS, SHAFT STRAIGHTENERS, ETC.—LATHE ATTACHMENTS—RAPID CHANGE GEAR MECHANISMS—LATHE TOOLS, HIGH-SPEED STEEL, SPEEDS AND FEEDS, POWER FOR CUTTING TOOLS, ETC.—TESTING A LATHE—LATHE WORK—ENGINE LATHES—HEAVY LATHES—HIGH-SPEED LATHES—SPECIAL LATHES—REGULAR TURRET LATHES—SPECIAL TURRET LATHES—ELECTRICALLY-DRIVEN LATHES.

LATHE-WORK. A Practical Treatise on the Tools, Appliances, and Processes employed in the Art of Turning. By PAUL N. HASLUCK. Eighth Edition. Crown 8vo, cloth 5s.

LAW FOR ENGINEERS AND MANUFACTURERS. See EVERY MAN'S OWN LAWYER. A Handybook of the Principles of Law and Equity. By a Barrister. Fiftieth (1913) Edition, Revised and Enlarged, including Abstracts of the Legislation of 1912 of especial interest to Engineering Firms and Manufacturers. Large crown 8vo, cloth, 850 pages [Just Published. Net 6s. 8d.]

LEVELLING, PRINCIPLES AND PRACTICE OF. Showing its Application to Purposes of Railway and Civil Engineering in the Construction of Roads; with Mr. TELFORD'S Rules for the same. By FREDERICK W. SIMMS, M.Inst.C.E. Ninth Edition, with LAW'S Practical Examples for Setting-out Railway Curves, and TRAUTWINE'S Field Practice of Laying-out Circular Curves. With seven Plates and numerous Woodcuts. 8vo 8s. 6d.

LIGHTNING CONDUCTORS, MODERN. An Illustrated Supplement to the Report of the Lightning Research Committee of 1905, also the Phoenix Fire Office 1910 Rules, with Notes as to the Methods of Protection, and Specifications. By KILLINGWORTH HEDGES, M.Inst.C.E., M.I.E.E., Honorary Secretary to the Lightning Research Committee. Second Edition, with additions. 132 pp., with Illustrations. Medium 8vo, cloth Net 6s. 6d.

"... The information given is most valuable."—*Electrical Engineer.*

"The work now appears with some additions that noticeably enhance its value."—*Scotsman.*

- LOCOMOTIVE ENGINE.** The Autobiography of an old Locomotive Engine. BY ROBERT WEATHERBURN, M.I.M.E. With Illustrations and Portraits of GEORGE and ROBERT STEPHENSON. Crown 8vo. cloth Net 2s. 6d.
- LOCOMOTIVE ENGINE DEVELOPMENT.** A Popular Treatise on the Gradual Improvements made in Railway Engines between 1803 and 1903. By CLEMENT C. STRETTON, C.E. Sixth Edition, Revised and Enlarged. Crown 8vo, cloth Net 4s. 6d.
- LOCOMOTIVE ENGINE DRIVING.** A Practical Manual for Engineers in Charge of Locomotive Engines. By MICHAEL REYNOLDS, M.S.E. Twelfth Edition. Crown 8vo, cloth, 3s. 6d.; cloth boards 4s. 6d.
- LOCOMOTIVE ENGINES.** A Rudimentary Treatise on. By G. D. DEMPSEY, C.E. With large additions treating of the Modern Locomotive, by D. K. CLARK, M.Inst.C.E. With Illustrations. Crown 8vo, cloth 3s.
- LOCOMOTIVE (MODEL) ENGINEER,** Fireman and Engine-boy. Comprising a Historical Notice of the Pioneer Locomotive Engines and their Inventors. By MICHAEL REYNOLDS. Crown 8vo, cloth, 3s. 6d.; cloth boards 4s. 6d.
- LOCOMOTIVES, THE APPLICATION OF HIGHLY SUPERHEATED STEAM TO.** See STEAM.
- MACHINERY, DETAILS OF.** Comprising Instructions for the Execution of various Works in Iron in the Fitting Shop, Foundry, and Boiler Yard. By FRANCIS CAMPIN, C.E. Crown 8vo, cloth 3s.
- MACHINE SHOP TOOLS.** A Practical Treatise describing in every detail the Construction, Operation and Manipulation of both Hand and Machine Tools; being a work of Practical Instruction in all Classes of Modern Machine Shop Practice, including Chapters on Filing, Fitting and Scraping Surfaces; on Drills, Reamers, Taps and Dies; the Lathe and its Tools; Planers, Shapers and their Tools; Milling Machines and Cutters; Gear Cutters and Gear Cutting; Drilling Machines and Drill Work, &c. By W. H. VAN DERVOORT, M.E., Illustrated by 673 Engravings. Medium 8vo Net 21s.
- MAGNETOS FOR AUTOMOBILISTS:** How made and How used. A Handybook on their Construction and Management. By S. R. BOTTONE. Second Edition, Enlarged. 118 pages, with 52 Illustrations. Crown 8vo, cloth Net 2s.
- MARINE ENGINEERING.** An Elementary Manual for Young Marine Engineers and Apprentices. By J. S. BREWER. Crown 8vo, cloth 1s. 6d.
- MARINE ENGINEER'S GUIDE** for Board of Trade Examinations for Certificates of Competency. Containing all Latest Questions to Date, with Simple, Clear, and Correct Solutions; with Notes on Beams, Boilers, Mechanical Powers, and the latest B.T. Regulations. By A. C. WANNAN, C.E., Consulting Engineer, and D. LINDSAY, Southampton Marine Academy. Illustrated with Sketches. Fifth Edition, Revised and further Enlarged. Large Crown 8vo, cloth. In 2 volumes, sold separately.
- ARITHMETIC** [Just Published. Net 6s.
- ELEMENTARY'S, VERBALS, AND DRAWINGS.**
[Just Published. Net 6s.

MARINE ENGINEER'S POCKET-BOOK. Containing latest Board of Trade Rules and Data for Marine Engineers. By A. C. WANNAN. Fifth Edition, 186 pages, Illustrated. Square 18mo, with thumb Index, leather Net 4s. 6d.

MARINE ENGINES AND BOILERS. Their Design and Construction. A Handbook for the Use of Students, Engineers, and Naval Constructors. Based on the Work "Berechnung und Konstruktion der Schiffsmaschinen und Kessel," by Dr. G. BAUER, Engineer-in-Chief of the Vulcan Shipbuilding Yard, Stettin. Translated from the Second German Edition by E. M. DONKIN and S. BRYAN DONKIN, A.M.I.C.E. Edited by LESLIE S. ROBERTSON, Secretary to the Engineering Standards Committee, M.I.C.E., M.I.M.E., M.I.N.A., Etc. With numerous Illustrations and Tables. Medium 8vo, cloth Net 25s.

SUMMARY OF CONTENTS:—PART I. MAIN ENGINES: DETERMINATION OF CYLINDER DIMENSIONS—THE UTILISATION OF STEAM IN THE ENGINE—STROKE OF PISTON—NUMBER OF REVOLUTIONS—TURNING MOMENT—BALANCING OF THE MOVING PARTS—ARRANGEMENT OF MAIN ENGINES—DETAILS OF MAIN ENGINES—THE CYLINDER—VALVES—VARIOUS KINDS OF VALVE GEAR—PISTON RODS—PISTONS—CONNECTING ROD AND CROSSHEAD—VALVE GEAR RODS—BED PLATES—ENGINE COLUMNS—REVERSING AND TURNING GEAR. PART II. PUMPS: AIR, CIRCULATING FEED, AND AUXILIARY PUMPS. PART III.: SHAFTING, RESISTANCE OF SHIPS, PROPELLERS: THRUST SHAFT AND THRUST BLOCK—TUNNEL SHAFTS AND PLUMMER BLOCKS—SHAFT COUPLINGS—STERN TUBE—THE SCREW PROPELLER—CONSTRUCTION OF THE SCREW. PART IV. PIPES AND CONNECTIONS: GENERAL REMARKS, FLANGES, VALVES, ETC.—UNDER-WATER FITTINGS—MAIN STEAM, AUXILIARY STEAM, AND EXHAUST PIPING—FEED WATER, BILGE, BALLAST AND CIRCULATING PIPES. PART V. STEAM BOILERS: FIRING AND THE GENERATION OF STEAM—CYLINDRICAL BOILERS—LOCOMOTIVE BOILERS—WATER-TUBE BOILERS—SMALL TUBE WATER-TUBE BOILERS—SMOKE BOX—FUNNEL AND BOILER LAGGING—FORCED DRAUGHT—BOILER FITTINGS AND MOUNTINGS. PART VI. MEASURING INSTRUMENTS. PART VII. VARIOUS DETAILS: BOLTS, NUTS, SCREW THREADS, ETC.—PLATFORMS, GRATINGS, LADDERS—FOUNDATIONS—SEATINGS—LUBRICATION—VENTILATION OF ENGINE ROOMS—RULES FOR SPARE GEAR. PART VIII. ADDITIONAL TABLES.

MARINE ENGINES AND STEAM VESSELS. By R. MURRAY, C.E. Eighth Edition, thoroughly Revised, with Additions by the Author and by GEORGE CARLISLE, C.E. Crown 8vo, cloth 4s. 6d.

MARINE INDICATOR CARDS, containing an exhaustive course of Indicator Diagrams specially arranged for Board of Trade First-Class Candidates, and also intended for the use of Marine Engineers of all Grades. By J. W. SOTHERN, M.I.E.S., Author of "The Marine Steam Turbine," &c. 163 pages with 180 illustrations. Medium 8vo, cloth.

Net 5s.

MARINE STEAM TURBINE. A Practical Description of the Parsons Marine Turbine as presently constructed, fitted, and run, intended for the use of Students, Marine Engineers, Superintendent Engineers, Draughtsmen, Works' Managers, Foremen Engineers, and others. By J. W. SOTHERN, M.I.E.S., Principal, Sothern's Marine Engineering College, Glasgow. Illustrated by over 180 Diagrams, Photographs, and Detail Drawings. Third Edition, re-written up to date and greatly enlarged. 354 pages. Medium 8vo, cloth ... Net 12s. 6d.

MARINE STEAM TURBINES. Forming the Supplementary Volume to "Marine Engines and Boilers." By DR. G. BAUER, Director of the Vulcan Works, Stettin, and O. LASCHE, Director of the A.E.G. Turbine Works, Berlin, assisted by E. LUDWIG and H. VOGEL. Translated from the German and edited by M. G. S. SWALLOW. 214 pages. With 103 Illustrations and 18 Tables. Medium 8vo, cloth.

Net 10s. 6d.

"The book is one of the best on the subject of Steam Turbine design."—*Practical Engineer.*

"The work is solid from first page to last, and the book is one which every student of turbine theory and practice, and every manufacturer of Turbine machines should add to his library."—*Mechanical Engineer.*

MASONRY DAMS FROM INCEPTION TO COMPLETION. Including numerous Formulæ, Forms of Specification and Tender, Pocket Diagram of Forces, etc. For the use of Civil and Mining Engineers. By C. F. COURTNEY, M.Inst.C.E. 8vo, cloth ... 9s.

MASTING, MAST-MAKING, AND RIGGING OF SHIPS. Also Tables of Spars, Rigging, Blocks; Chain, Wire, and Hemp Ropes, etc., relative to every class of vessels. By R. KIPPING. Crown 8vo, cloth ... 2s.

MATERIALS AND CONSTRUCTION. A Theoretical and Practical Treatise on the Strains, Designing, and Erection of Works of Construction. By F. CAMPIN. Crown 8vo, cloth ... 3s.

MATERIALS, A TREATISE ON THE STRENGTH OF. By P. BARLOW, F.R.S., P. W. BARLOW, F.R.S., and W. H. BARLOW, F.R.S. Edited by WM. HUMBER, A.M.Inst.C.E. 8vo, cloth ... 18s.

MATHEMATICAL TABLES. For Trigonometrical, Astronomical, and Nautical Calculations; to which is prefixed a Treatise on Logarithms, by H. LAW, C.E. With Tables for Navigation and Nautical Astronomy. By Prof. J. R. YOUNG. Crown 8vo, cloth ... 4s.

MEASURES: BRITISH AND AMERICAN CUSTOMARY AND METRIC LEGAL MEASURES. For Commercial and Technical Purposes, forming the Measure Section of Part I. of "The Mechanical Engineer's Reference Book." By NELSON FOLEY, M.I.N.A. Folio, cloth ... Net 7s. 6d.

MECHANICAL ENGINEERING. Comprising Metallurgy, Moulding, Casting, Forging, Tools, Workshop Machinery, Mechanical Manipulation, Manufacture of the Steam Engine, etc. By FRANCIS CAMPIN, C.E. Third Edition. Crown 8vo, cloth ... 2s. 6d.

MECHANICAL ENGINEERING TERMS. LOCKWOOD'S DICTIONARY. Embracing terms current in the Drawing Office, Pattern Shop, Foundry, Fitting, Turning, Smiths', and Boiler Shops, etc. Comprising upwards of 6,000 Definitions. Edited by J. G. HÖRNER, A.M.I.M.E. Fourth Edition, Revised, with Additions. Crown 8vo, cloth. [Just Published. Net 7s. 6d.]

MECHANICAL ENGINEER'S COMPANION. Areas, Circumferences, Decimal Equivalents, in inches and feet, millimetres, squares, cubes, roots, etc.; Strength of Bolts, Weight of Iron, etc.; Weights, Measures, and other Data. Also Practical Rules for Engine Proportions. By R. EDWARDS, M.Inst.C.E. Fcap. 8vo, cloth. 3s. 6d.

MECHANICAL ENGINEER'S POCKET-BOOK. Comprising Tables, Formulæ, Rules, and Data: A Handy Book of Reference for Daily use in Engineering Practice. By the late D. KINNEAR CLARK, M.Inst.C.E. 1913 Edition, Revised and Enlarged. By H. H. P. POWLES, A.M.Inst.C.E., M.I.M.E. Small 8vo, 700 pp., Limp cloth. [Just Published. Net 4s. 6d.]

MATHEMATICAL TABLES—MEASUREMENT OF SURFACES AND SOLIDS—ENGLISH WEIGHTS AND MEASURES—FRENCH METRIC WEIGHTS AND MEASURES—FOREIGN WEIGHTS AND MEASURES—MONEYS—SPECIFIC GRAVITY, WEIGHT, AND VOLUME—MANUFACTURED METALS—STEEL PIPES—BOLTS AND NUTS—SUNDRY ARTICLES IN WROUGHT AND CAST IRON, COPPER, BRASS, LEAD, TIN, ZINC—STRENGTH OF MATERIALS—STRENGTH OF TIMBER—STRENGTH OF CAST IRON—STRENGTH OF WROUGHT IRON—STRENGTH OF STEEL—TENSILE STRENGTH OF COPPER, LEAD, ETC.—RESISTANCE OF STONES AND OTHER BUILDING MATERIALS—RIVETED JOINTS IN BOILER PLATES—BOILER SHELLS—WIRE ROPES AND HEMP ROPES—CHAINS AND CHAIN CABLES—FRAMING—HARDNESS OF METALS, ALLOYS, AND STONES—LABOUR OF ANIMALS—MECHANICAL PRINCIPLES—GRAVITY AND FALL OF BODIES—ACCELERATING AND RETARDING FORCES—MILL GEARING, SHAFTING, ETC.—TRANSMISSION OF MOTIVE POWER—HEAT—COMBUSTION: FUELS—WARMING, VENTILATION, COOKING STOVES—STEAM—STEAM ENGINES AND BOILERS—RAILWAYS—TRAMWAYS—STEAM SHIPS—PUMPING STEAM ENGINES AND PUMPS—COAL GAS—GAS ENGINES, ETC.—AIR IN MOTION—COMPRESSED AIR—HOT-AIR ENGINES—WATER POWER—SPEED OF CUTTING TOOLS—COLOURS—ELECTRICAL ENGINEERING.

MECHANICAL HANDLING OF MATERIAL. A Treatise on the Handling of Material such as Coal, Ore, Timber, etc., by Automatic or Semi-Automatic Machinery, together with the Various Accessories used in the Manipulation of such Plant, and Dealing fully with the Handling, Storing, and Warehousing of Grain. By G. F. ZIMMER, A.M.Inst.C.E. 528 pp. Royal 8vo, cloth, with 550 Illustrations (including Folding Plates) specially prepared for the Work ... *Net 25s.*

MECHANICS. Being a concise Exposition of the General Principles of Mechanical Science and their Applications. By C. TOMLINSON, F.R.S. Crown 8vo, cloth **1s. 6d.**

MECHANICS CONDENSED. A Selection of Formulæ, Rules, Tables, and Data for the Use of Engineering Students, etc. By W. G. C. HUGHES, A.M.I.C.E. Crown 8vo, cloth **2s. 6d.**

MECHANICS OF AIR MACHINERY. By Dr. J. WIESBACH and Prof. G. HERRMANN. Authorised Translation with an Appendix on American Practice by A. TROWBRIDGE, Ph.B., Adjunct Professor of Mechanical Engineering, Columbia University. Royal 8vo, cloth. *Net 18s.*

MECHANICS' WORKSHOP COMPANION. Comprising a great variety of the most Useful Rules and Formulæ in Mechanical Science, with numerous Tables of Practical Data and Calculated Results for Facilitating Mechanical Operations. By WILLIAM TEMPLETON, Author of "The Engineer's Practical Assistant," etc., etc. Nineteenth Edition, Revised, Modernised, and considerably Enlarged by W. S. HUTTON, C.E., Author of "The Works' Manager's Handbook," etc. Fcap. 8vo, nearly 500 pp., with 8 Plates and upwards of 270 Diagrams, leather *Net 5s.*

MECHANISM AND MACHINE TOOLS. By T. BAKER, C.E. With Remarks on Tools and Machinery by J. NASMYTH, C.E. Crown 8vo, cloth **2s. 6d.**

MENSURATION AND MEASURING. With the Mensuration and Levelling of Land for the Purposes of Modern Engineering. By T. BAKER, C.E. New Edition by E. NUGENT, C.E. Crown 8vo, cloth... .. **1s. 6d.**

METAL-TURNING. A Practical Handbook for Engineers, Technical Students, and Amateurs. By JOSEPH HORNER, A.M.I.Mech.E., Author of "Pattern Making," etc. Large Crown 8vo, cloth, with 488 Illustrations *Net 9s.*

SUMMARY OF CONTENTS:—INTRODUCTION—RELATIONS OF TURNERY AND MACHINE SHOP—**SEC. I. THE LATHE, ITS WORK AND TOOLS—**FORMS AND FUNCTIONS OF TOOLS—REMARKS ON TURNING IN GENERAL—**SEC. II. TURNING BETWEEN CENTRES—**CENTRING AND DRIVING—USE OF STEADIES—EXAMPLES OF TURNING INVOLVING LINING-OUT FOR CENTRES—MANDREL WORK—**SEC. III. WORK SUPPORTED AT ONE END—**FACE PLATE TURNING—ANGLE PLATE TURNING—INDEPENDENT JAW CHUCKS—CONCENTRIC, UNIVERSAL, TOGGLE, AND APPLIED CHUCKS—**SEC. IV. INTERNAL WORK—**DRILLING, BORING, AND ALLIED OPERATIONS—**SEC. V. SCREW CUTTINGS AND TURRET WORK—**SEC. VI. MISCELLANEOUS—SPECIAL WORK—MEASUREMENT, GRINDING—TOOL HOLDERS—SPEED AND FEEDS, TOOL STEELS—STEEL MAKERS' INSTRUCTIONS.

METRIC TABLES. In which the British Standard Measures and Weights are compared with those of the Metric System at present in Use on the Continent. By C. H. DOWLING, C.E. 8vo, cloth. **10s. 6d.**

MILLING MACHINES: their Design, Construction, and Working. A Handbook for Practical Men and Engineering Students. By JOSEPH HORNER, A.M.I.Mech.E., Author of "Pattern Making," etc. With 269 Illustrations. Medium 8vo, cloth ... *Net 12s. 6d.*

MOTOR CAR (THE MODERN), ITS MANAGEMENT, MECHANISM AND MAINTENANCE. A Practical Handbook for the Use of Owners and Drivers. By W. GALLOWAY DUNCAN, M.I.M.E., M.I.A.E., Lecturer on Automobile Engineering, Willesden Polytechnic. Late Principal of H.M. Government School of Engineering, Dacca, India. Second Edition, Revised. 120 pages, with Illustrations. Crown 8vo, cloth... .. *[Just Published. Net 2s. 6d.]*

MOTOR CAR CATECHISM. Containing about 320 Questions and Answers Explaining the Construction and Working of a Modern Motor Car, with a chapter on Motor Cycles. For the Use of Owners, Drivers, and Students. By JOHN HENRY KNIGHT. Fourth Edition, Revised. Crown 8vo, with Illustrations ... *[Just Published. Net 1s. 6d.]*

MOTOR CAR CONSTRUCTION. A Practical Manual for Engineers, Students, and Motor Car Owners. With Notes on Wind Resistance and Body Design. By ROBERT W. A. BREWER, Fellow of the Society of Engineers (Gold Medallist and Bessemer Prizeman), Assoc.M.Inst.C.E., M.I.Mech.E., M.I.Automobile E., Author of "The Art of Aviation." 25c pp. With numerous Illustrations. Demy 8vo, cloth. *[Just Published. Net 5s.]*

HISTORY OF THE INTERNAL COMBUSTION ENGINE—MECHANICAL DETAILS OF CONSTRUCTION—CONNECTING RODS, CRANKS AND VALVES—VALVE ACTUATING MECHANISM—STRATIFICATION—THERMAL EFFICIENCY—CAUSE AND EXTENT OF HEAT LOSSES—TESTING OF GAS ENGINES AND CALCULATIONS OF RESULTS—IGNITION MECHANISM—POWER AND WEIGHT OF PETROL ENGINES—FRICTION AND LUBRICATION OF ENGINES—TWO-CYCLE AND FOUR-CYCLE ENGINES CONTRASTED—CLUTCHES AND CHANGE SPEED GEARS—TRANSMISSION GEAR—LIVE AXLES, BEVEL, AND WORM DRIVE—THE DIFFERENTIAL GEAR—BRAKES—A REVIEW OF MODERN PRACTICE—FRAMES—SUSPENSION—FRONT AXLES AND STEERING GEARS—RADIATION—CARBURATION—LIQUID FUEL—CARBURETTORS AND THE FLOW OF FUEL—WIND RESISTANCE AND BODY DESIGN.

MOTOR CARS FOR COMMON ROADS. By A. J. WALLIS-TAYLER, A.M.Inst.C.E. 212 pp., with 76 Illustrations. Crown 8vo, cloth... .. *4s. 6d.*

MOTOR CARS; THE GASOLINE AUTOMOBILE. A Practical Discussion of the Development and Present Status of the Automobile. By V. LOUGHEED, Founder Member, Society of Automobile Engineers, and MORRIS A. HALL, American Society of Mechanical Engineers. 318 pp., profusely Illustrated. Royal 8vo, cloth.

[Just Published. Net 8s. 6d.]

MOTOR VEHICLES FOR BUSINESS PURPOSES. A Practical Handbook for those interested in the Transport of Passengers and Goods. By A. J. WALLIS-TAYLER, A.M.Inst.C.E. With 134 Illustrations. Demy 8vo, cloth *Net 9s.*

NAVAL ARCHITECT'S AND SHIPBUILDER'S POCKET-BOOK. Of Formulæ, Rules, and Tables, and Marine Engineer's and Surveyor's Handy Book of Reference. By CLEMENT MACKROW, M.I.N.A. Tenth Edition. Fcap., leather *Net 12s. 6d.*

SIGNS AND SYMBOLS, DECIMAL FRACTIONS—TRIGONOMETRY—PRACTICAL GEOMETRY—MENSURATION—CENTRES AND MOMENTS OF FIGURES—MOMENTS OF INERTIA AND RADII OF GYRATION—ALGEBRAICAL EXPRESSIONS FOR SIMPSON'S RULES—MECHANICAL PRINCIPLES—CENTRE OF GRAVITY—LAWS OF MOTION—DISPLACEMENT, CENTRE OF BUOYANCY—CENTRE OF GRAVITY OF SHIP'S HULL—STABILITY CURVES AND METACENTRES—SEA AND SHALLOW-WATER WAVES—ROLLING OF SHIPS—PROPULSION AND RESISTANCE OF VESSELS—SPEED TRIALS—SAILING, CENTRE OF EFFORT—DISTANCES DOWN RIVERS, COAST LINES—STEERING AND RUDERS OF VESSELS—LAUNCHING CALCULATIONS AND VELOCITIES—WEIGHT OF MATERIAL AND GEAR—GUN PARTICULARS AND WEIGHT—STANDARD GAUGES—RIVETED JOINTS AND RIVETING—STRENGTH AND TESTS OF MATERIALS—BINDING AND SHEARING STRESSES—STRENGTH OF SHAFTING, PILLARS, WHEELS, ETC., ETC.

- NAVAL ARCHITECTURE.** An Exposition of the Elementary Principles. By J. PEAKE. Crown 8vo, cloth 3s. 6d.
- NAVIGATION AND NAUTICAL ASTRONOMY.** In Theory and Practice. By Prof. J. R. YOUNG. Crown 8vo, cloth. 2s. 6d.
- NAVIGATION, PRACTICAL.** Consisting of the Sailor's Sea Book, by J. GREENWOOD and W. H. ROSSER; together with Mathematical and Nautical Tables for the Working of the Problems, by H. LAW, C.E., and Prof. J. R. YOUNG 7s.
- PATTERN MAKING.** Embracing the Main Types of Engineering Construction, and including Gearing, Engine Work, Sheaves and Pulleys, Pipes and Columns, Screws, Machine Parts, Pumps and Cocks, the Moulding of Patterns in Loam and Greensand, Weight of Castings, etc. By J. G. HORNER, A.M.I.M.E. Fourth Edition, thoroughly Revised and much Enlarged. 420 pp., with about 500 Illustrations. Large Crown 8vo, cloth Net 7s. 6d.
- PATTERN MAKING.** A Practical Work on the Art of Making Patterns for Engineering and Foundry Work, including (among other matter) Materials and Tools, Wood Patterns, Metal Patterns, Pattern Shop Mathematics, Cost, Care, etc., of Patterns. By F. W. BARROWS. Fully Illustrated by Engravings made from Special Drawings by the Author. Crown 8vo, cloth Net 6s.
- PETROL AIR GAS.** A Practical Handbook on the Installation and Working of Air Gas Lighting Systems for Country Houses. By HENRY O'CONNOR, F.R.S.E., A.M.Inst.C.E., &c., author of "The Gas Engineer's Pocket Book." Second Edition, Revised and Enlarged. 100 pages with Illustrations. Crown 8vo, cloth. [Just Published. Net 1s. 6d.]
- PETROLEUM MINING AND OIL-FIELD DEVELOPMENT.** A Guide to the Exploration of Petroleum Lands, and a Study of the Engineering Problems connected with the Winning of Petroleum. Including Statistical Data of important Oil Fields. Notes on the Origin and Distribution of Petroleum, and a description of the Methods of Utilising Oil and Gas Fuel. By A. BEEBY THOMPSON, A.M.I.Mech.E., F.G.S., Author of "The Oil Fields of Russia." 384 pages, 114 Illustrations, including 22 full-page plates. Demy 8vo, cloth. Net 15s.
- PIONEER ENGINEERING.** A Treatise on the Engineering Operations connected with the Settlement of Waste Lands in New Countries. By E. DOBSON, M.Inst.C.E. Second Edition. Crown 8vo, cloth 4s. 6d.
- PNEUMATICS.** Including Acoustics and the Phenomena of Wind Currents, for the Use of Beginners. By CHARLES TOMLINSON, F.R.S. Crown 8vo, cloth 1s. 6d.
- PORTLAND CEMENT, THE MODERN MANUFACTURE OF.** A Handbook for Manufacturers, Users, and all interested in Portland Cement. By PERCY C. H. WEST, Fellow of the Chemical Society and of the Society of Chemical Industry. Vol. I. "Machinery and Kilns." 280 pages, with 159 Illustrations and numerous tables. Royal 8vo, cloth Net 12s. 6d.
- PRODUCER GAS PRACTICE (AMERICAN) AND INDUSTRIAL GAS ENGINEERING.** By NISBET LATTA, M.Amer. Soc.M.E., M.Amer. Gas Inst. 558 pp., with 247 Illustrations. Demy 4to, cloth Net 25s.

PRODUCER GAS PRACTICE.—*continued.*

PRODUCER OPERATION—CLEANING THE GAS—WORKS DETAILS—PRODUCER TYPES—MOVING GASES—SOLID FUELS—PHYSICAL PROPERTIES OF GASES—CHEMICAL PROPERTIES OF GASES—GAS ANALYSIS—GAS POWER—GAS ENGINES—INDUSTRIAL GAS APPLICATIONS—FURNACES AND KILNS—BURNING LIME AND CEMENT—PRE-HEATING AIR—DOHERTY COMBUSTION ECONOMIZER—COMBUSTION IN FURNACES—HEAT—TEMPERATURE, RADIATION, AND CONDUCTION—HEAT MEASUREMENTS; PYROMETRY AND CALORIMETRY—PIPES, FLUES, AND CHIMNEYS—MATERIALS: FIRECLAY, MASONRY, WEIGHTS. AND ROPE—USEFUL TABLES—OIL FUEL PRODUCER GAS.

PRODUCER GAS. See also GAS ENGINES AND PRODUCER GAS PLANTS.

PUMPS AND PUMPING. A Handbook for Pump Users. Being Notes on Selection, Construction, and Management. By M. POWIS BALE, M.Inst.C.E., M.I.Mech.E. Sixth Edition. Crown 8vo, cloth, **3s. 6d.**

PUNCHES, DIES, AND TOOLS FOR MANUFACTURING IN PRESSES. By JOSEPH V. WOODWORTH. Medium 8vo, cloth, 482 pages with 700 Illustrations *Net 16s.*

RECLAMATION OF LAND FROM TIDAL WATERS. A Handbook for Engineers, Landed Proprietors, and others interested in Works of Reclamation. By A. BEAZELEY, M.Inst.C.E. 8vo, cloth *Net 10s. 6d.*

RECOIL OF GUNS WITH RECOIL CYLINDERS, THE THEORY OF. By Professor F. RAUSENBERGER. Specially printed from "Artilleristische Monatshefte." Translated by ALFRED SLATER. 100 pages, with 3 Plates. Demy 8vo, cloth *Net 10s. 6d.*

REFRIGERATION AND ICE-MAKING POCKET-BOOK. By A. J. WALLIS-TAYLER, A.M.Inst.C.E., Author of "Refrigerating and Ice-making Machinery," etc. Fifth Edition, Revised. Cr. 8vo, cloth. *Net 3s. 6d.*

REFRIGERATION, COLD STORAGE, AND ICE-MAKING. A Practical Treatise on the Art and Science of Refrigeration. By A. J. WALLIS-TAYLER, A.M.Inst.C.E. Containing the Third Edition of "Refrigerating and Ice-Making Machinery." Third Edition, Thoroughly Revised. 654 pp., 414 Illus. Medium 8vo, cloth. *Net 10s. 6d.*

REINFORCED CONCRETE. A Handbook for Architects, Engineers and Contractors. By F. D. WARREN, Massachusetts Institute of Technology, with Illustrations, 271 pages. Crown 8vo cloth. *Net 10s. 6d.*

REINFORCED CONCRETE DESIGN. A Graphical Handbook by JOHN HAWKESWORTH, C.E., consisting of a series of Plates showing graphically, by means of plotted curves, the required design for Slabs, Beams and Columns, under various conditions of external loading, together with practical examples explaining the method of using each Plate. With an Appendix containing the requirements of the Building Code of New York City in regard to Reinforced Concrete. 64 pages. 15 Full-page Plates. 4to, cloth... .. *Net 12s.*

REINFORCED CONCRETE DESIGN SIMPLIFIED. Diagrams, Tables, and other Data for Designing and Checking accurately and speedily. By JOHN C. GAMMON, B.Sc. Eng. (London); Assoc. City Guilds Institute; Member of the Concrete Institute; Assistant Engineer, Public Works Department, India. With an Introduction by H. KEMPTON DYSON, Secretary of The Concrete Institute; Lecturer on Reinforced Concrete, London County Council School of Building. Demy 4to, cloth. 122 pages. With Thumb Index. ... *Net 10s. 6d.*

- REINFORCED CONCRETE DIAGRAMS.** For the Calculation of Beams, Slabs, and Columns in Reinforced Concrete. By G. S. COLEMAN, A.M.Inst.C.E. Royal 4to, cloth ... *Net* 3s. 6d.
- RIVER BARS.** The Causes of their Formation, and their Treatment by "Induced Tidal Scour"; with a Description of the Successful Reduction by this Method of the Bar at Dublin. By I. J. MANN, Assist. Eng. to the Dublin Port and Docks Board. Royal 8vo, cloth. 7s. 6d.
- ROADS AND STREETS.** By H. LAW, C.E., and D. K. CLARK, C.E. Revised, with Additional Chapters by A. J. WALLIS-TAYLER, A.M.Inst.C.E. Seventh Edition. Crown 8vo, cloth 6s.
- ROOFS OF WOOD AND IRON.** Deduced chiefly from the Works of Robison, Tredgold, and Humber. By E. W. TARN, M.A., Architect. Fifth Edition. Crown 8vo, cloth 1s. 6d.
- SAFE RAILWAY WORKING.** A Treatise on Railway Accidents, their Cause and Prevention; with a Description of Modern Appliances and Systems. By CLEMENT E. STRETTON, C.E. Third Edition, Enlarged. Crown 8vo, cloth 3s. 6d.
- SAFE USE OF STEAM.** Containing Rules for Unprofessional Steam Users. By an ENGINEER. Eighth Edition. Sewed 6d.
- SAILMAKING.** By SAMUEL B. SADLER, Practical Sailmaker, late in the employment of Messrs. Ratsey and Laphorne, of Cowes and Gosport. Second Edition, Revised. 4to, cloth ... *Net* 12s. 6d.
- SAILOR'S SEA BOOK.** A Rudimentary Treatise on Navigation. By JAMES GREENWOOD, B.A. With numerous Woodcuts and Coloured Plates. New and Enlarged Edition. By W. H. ROSSER. Crown 8vo cloth 2s. 6d.
- SAILS AND SAILMAKING.** With Draughting, and the Centre of Effort of the Sails. Weights and Sizes of Ropes; Mastng, Rigging and Sails of Steam Vessels, etc. By R. KIPPING, N.A. Crown 8vo, cloth 2s. 6d.
- SCREW-THREADS,** and Methods of Producing Them. With numerous Tables and complete Directions for using Screw-Cutting Lathes. By PAUL N. HASLUCK, Author of "Lathe-Work," etc. Sixth Edition. Waistcoat-pocket size 1s. 6d.
- SEA TERMS, PHRASES, AND WORDS** (Technical Dictionary. French-English, English-French), used in the English and French Languages. For the Use of Seamen, Engineers, Pilots, Shipbuilders, Shipowners, and Shipbrokers. Compiled by W. PIRRIE, late of the African Steamship Company. Fcap. 8vo, cloth 5s.
- SEWERAGE OF SEA COAST TOWNS.** By HENRY C. ADAMS, A.M.Inst.C.E., M.I.Mech.E., A.M.I.E.E., M.R.San.Inst., &c. 132 pages, with Illustrations. Crown 8vo, cloth *Net* 5s.
- SEWERAGE SYSTEMS.** Their Design and Construction. A Practical Treatise upon the Principles of the Design, Construction, and Maintenance of Town Sewage Systems, with Examples of Existing Works. By HUGH S. WATSON, A.M.Inst.C.E. With Legal Notes by ELIDYR B. HERBERT, Barrister-at-Law. 330 pages. Illustrated by 150 Diagrams and Working Drawings Royal 8vo, cloth. *Net* 10s. 6d.

- SHIPBUILDING INDUSTRY OF GERMANY.** Compiled and Edited by G. LEHMANN-FELSKOWSKI. With Coloured Prints, Art Supplements, and numerous Illustrations throughout the text. Super-royal 4to, cloth *Net 10s. 6d.*
- SHIPS AND BOATS.** By W. BLAND. With numerous Illustrations and Models. Tenth Edition. Crown 8vo, cloth *1s. 6d.*
- SHIPS FOR OCEAN AND RIVER SERVICE.** Principles of the Construction of. By H. A. SOMMERFELDT. Crown 8vo. *1s. 6d.*
- ATLAS OF ENGRAVINGS.** To illustrate the above. Twelve large folding Plates. Royal 4to, cloth *7s. 6d.*
- SMITHY AND FORGE.** Including the Farrier's Art and Coach Smithing. By W. J. E. CRANE. Crown 8vo, cloth *2s. 6d.*
- STATIONARY ENGINE DRIVING.** A Practical Manual for Engineers in Charge of Stationary Engines. By MICHAEL REYNOLDS, M.S.E. Eighth Edition. Crown 8vo, cloth *3s. 6d.*; cloth boards *4s. 6d.*
- STATIONARY ENGINES.** A Practical Handbook of their Care and Management for Men-in-Charge. By C. HURST. Crown 8vo. *Net 1s.*
- STEAM: THE APPLICATION OF HIGHLY SUPER-HEATED STEAM TO LOCOMOTIVES.** Being a reprint from a Series of Articles appearing in "The Engineer." By ROBERT GARBE, Privy Councillor, Prussian State Railways. Translated from the German. Edited by LESLIE S. ROBERTSON, Secretary of the Engineering Standards Committee, M.Inst.C.E., M.I.Mech.E., M.Inst.N.A., etc. Medium 8vo, cloth *7s. 6d.*
- STEAM AND THE STEAM ENGINE.** Stationary and Portable. Being an Extension of the Treatise on the Steam Engine of Mr. J. SEWELL. By D. K. CLARK, C.E. Fourth Edition. Crown 8vo, cloth *3s. 6d.*
- STEAM AND MACHINERY MANAGEMENT.** A Guide to the Arrangement and Economical Management of Machinery, with Hints on Construction and Selection. By M. POWIS BALE, M.Inst.M.E. Crown 8vo, cloth *2s. 6d.*
- STEAM ENGINE.** A Practical Handbook compiled with especial Reference to Small and Medium-sized Engines. For the Use of Engine Makers, Mechanical Draughtsmen, Engineering Students, and users of Steam Power. By HERMAN HAEDER, C.E. Translated from the German, with additions and alterations, by H. H. P. POWLES, A.M.I.C.E., M.I.M.E. Third Edition, Revised. With nearly 1,100 Illustrations. Crown 8vo, cloth *Net 7s. 6d.*
- "This is an excellent book, and should be in the hands of all who are interested in the construction and design of medium-sized stationary engines. . . . A careful study of its contents and the arrangement of the sections leads to the conclusion that there is probably no other book like it in this country. The volume aims at showing the results of practical experience, and it certainly may claim a complete achievement of this idea."—*Nature.*
- STEAM ENGINE.** A Treatise on the Mathematical Theory of, with Rules and Examples for Practical Men. By T. BAKER, C.E. Crown 8vo, cloth *1s. 6d.*
- STEAM ENGINE.** For the Use of Beginners. By Dr. LARDNER. Crown 8vo, cloth *1s. 6d.*

STEAM ENGINE. A Text-Book on the Steam Engine, with a Supplement on Gas Engines and Part II. on Heat Engines. By T. M. GOODEVE, M.A., Barrister-at-Law, Professor of Mechanics at the Royal College of Science, London; Author of "The Principles of Mechanics," "The Elements of Mechanism," etc. Fourteenth Edition. Crown 8vo, cloth 6s.

STEAM ENGINE (PORTABLE): ITS CONSTRUCTION AND MANAGEMENT. A Practical Manual for Owners and Users of Steam Engines generally. By W. D. WANSBROUGH. 180 pages, with 118 Illustrations. Demy 8vo, cloth.

STEAM ENGINEERING IN THEORY AND PRACTICE. By GARDNER D. HISCOX, M.E. With Chapters on Electrical Engineering. By NEWTON HARRISON, E.E., Author of "Electric Wiring, Diagrams, and Switchboards." 450 pages. Over 400 Detailed Engravings. *Net 12s. 6d.*

HISTORICAL—STEAM AND ITS PROPERTIES—APPLIANCES FOR THE GENERATION OF STEAM—TYPES OF BOILERS—CHIMNEY AND ITS WORK—HEAT ECONOMY OF THE FEED WATER—STEAM PUMPS AND THEIR WORK—INCORUSTATION AND ITS WORK—STEAM ABOVE ATMOSPHERIC PRESSURE—FLOW OF STEAM FROM NOZZLES—SUPERHEATED STEAM AND ITS WORK—ADIABATIC EXPANSION OF STEAM—INDICATOR AND ITS WORK—STEAM ENGINE PROPORTIONS—SLIDE VALVE ENGINES AND VALVE MOTION—CORLISS ENGINE AND ITS VALVE GEAR—COMPOUND ENGINE AND ITS THEORY—TRIPLE AND MULTIPLE EXPANSION ENGINE—STEAM TURBINE—REFRIGERATION—ELEVATORS AND THEIR MANAGEMENT—COST OF POWER—STEAM ENGINE TROUBLES—ELECTRIC POWER AND ELECTRIC PLANTS.

STEAM TURBINE. See MARINE STEAM TURBINE.

STONE BLASTING AND QUARRYING. For Building and other Purposes. With Remarks on the Blowing up of Bridges. By Gen. Sir J. BURGOYNE, K.C.B. Crown 8vo, cloth 1s. 6d.

STONE QUARRYING AND THE PREPARATION OF STONE FOR THE MARKET. By ALLAN GREENWELL, A.M.Inst.C.E., and Dr. J. V. ELSDEN. [*In Preparation.*] Price about *Net 10s. 6d.*

STONE-WORKING MACHINERY. A Manual dealing with the Rapid and Economical Conversion of Stone. With Hints on the Arrangement and Management of Stone Works. By M. POWIS BALE, M.Inst.C.E. Crown 8vo, cloth 9s.

STRAINS, HANDY BOOK FOR THE CALCULATION OF. In Girders and Similar Structures and their Strength. Consisting of Formulæ and Corresponding Diagrams, with numerous details for Practical Application, etc. By WILLIAM HUMBER, A.M.Inst.C.E., etc. Sixth Edition. Crown 8vo, with nearly 100 Woodcuts and 3 Plates, cloth 7s. 6d.

STRAINS ON STRUCTURES OF IRONWORK. With Practical Remarks on Iron Construction. By F. W. SHEILDS, M.Inst.C.E. 8vo, cloth 5s.

SUBMARINE TELEGRAPHS. Their History, Construction, and Working, together with an appendix on "Wireless Telegraphy." Compiled from Authoritative and Exclusive Sources. By CHARLES BRIGHT, F.R.S.E., M.Inst.C.E., M.I.Mech.E., M.I.E.E. Super royal 8vo, nearly 800 pages, fully Illustrated, including a large number of Maps and Folding Plates, strongly bound in cloth *Net £3 3s.*

SUPERHEATED STEAM, THE APPLICATION OF, TO LOCOMOTIVES. See STEAM.

SURVEYING AS PRACTISED BY CIVIL ENGINEERS AND SURVEYORS. Including the Setting-out of Works for Construction and Surveys Abroad, with many Examples taken from Actual Practice. A Handbook for Use in the Field and the Office, intended also as a Text-book for Students. By JOHN WHITELAW, Jun., A.M.Inst.C.E., Author of "Points and Crossings." With about 260 Illustrations. Second Edition. Demy 8vo, cloth Net 10s. 6d.

SURVEYING WITH THE CHAIN ONLY—SURVEYING WITH THE AID OF ANGULAR INSTRUMENTS—LEVELLING—ADJUSTMENT OF INSTRUMENTS—RAILWAY (INCLUDING ROAD) SURVEYS AND SETTING OUT—TACHEOMETRY OR STADIA SURVEYING—TUNNEL ALIGNMENT AND SETTING OUT—SURVEYS FOR WATER SUPPLY WORKS—HYDROGRAPHICAL OR MARINE SURVEYING—ASTRONOMICAL OBSERVATIONS USED IN SURVEYING—EXPLANATION OF ASTRONOMICAL TERMS—SURVEYS ABROAD IN JUNGLE, DENSE FOREST, AND UNMAPPED OPEN COUNTRY—TRIGONOMETRICAL OR GEODETIC SURVEYS.

SURVEYING SHEETS FOR PROFESSIONAL AND EDUCATIONAL USE. A series of 26 Blank Ruled Forms for use in the Field, of which 20 are ruled under the following headings:—Chaining; Traverse; Prismatic Compass; Tacheometer; Setting-out Curve; Levelling. By a Professional Instructor. Oblong royal 8vo, paper wrapper with stiff back... .. Net 1s. 6d.

SURVEYING, LAND AND ENGINEERING. For Students and Practical Use. By T. BAKER, C.E. Twentieth Edition, by F. E. DIXON, A.M.Inst.C.E. With Plates and Diagrams. Crown 8vo, 2s.

SURVEYING, LAND AND MARINE. In Reference to the Preparation of Plans for Roads and Railways; Canals, Rivers, Towns Water Supplies; Docks and Harbours. With Description and Use of Surveying Instruments. By W. DAVIS HASKOLL, C.E. Second Edition, Revised, with Additions. Large Crown 8vo, cloth 9s.

SURVEYING, LAND AND MINING. As applied to Collieries and other Mines. For Students, Colliery Officials and Mine Surveyors. By G. L. LESTON. 308 pp., with 207 Illustrations, and 3 folding Plates. Large crown 8vo, cloth. [Just Published. Net 6s.

SURVEYING, PRACTICAL. A Text-book for Students Preparing for Examinations or for Survey Work in the Colonies. By GEORGE W. USILL, A.M.Inst.C.E. Tenth Edition, thoroughly Revised and Enlarged by ALEX. BEAZELEY, M.Inst.C.E. With 4 Lithographic Plates and 360 Illustrations. Large crown 8vo, 7s. 6d. cloth; or, on thin paper, leather, gilt edges, rounded corners, for pocket use. 12s. 6d.

ORDINARY SURVEYING—SURVEYING INSTRUMENTS—TRIGONOMETRY REQUIRED IN SURVEYING—CHAIN-SURVEYING—THEODOLITE SURVEYING—TRAVERSING—TOWN-SURVEYING—LEVELLING—CONTOURING—SETTING OUT CURVES—OFFICE WORK—LAND QUANTITIES—COLONIAL LICENSING REGULATIONS—HYPSOMETER TABLES—INTRODUCTION TO TABLES OF NATURAL SINES, ETC.—NATURAL SINES AND CO-SINES—NATURAL TANGENTS AND CO-TANGENTS—NATURAL SECANTS AND CO-SECANTS.

SURVEYING, TRIGONOMETRICAL. An Outline of the Method of Conducting a Trigonometrical Survey. For the Formation of Geographical and Topographical Maps and Plans, Military Reconnaissance, Levelling, etc. By Lieut.-General FROME, R.E. Fourth Edition, Revised by Major-General Sir CHARLES WARREN. With 19 Plates and 115 Woodcuts. Royal 8vo, cloth 16s.

SURVEYING WITH THE TACHEOMETER. A Practical Manual for the Use of Civil and Military Engineers and Surveyors, including two series of Tables specially computed for the Reduction of Readings in Sexagesimal and in Centesimal Degrees. By NEIL KENNEDY, M.Inst.C.E. 112 pp. With Diagrams and Plates. Third Edition, Revised. Demy 8vo, cloth [Just Published. Net 10s. 6d.

SURVEY PRACTICE. For Reference in Surveying, Levelling, and Setting-out; and in Route Surveys of Travellers by Land and Sea. With Tables, Illustrations, and Records. By L. D'A. JACKSON, A.M.Inst.C.E. Third Edition. 8vo, cloth 12s. 6d.

SURVEYOR'S FIELD BOOK FOR ENGINEERS AND MINING SURVEYORS. Consisting of a Series of Tables, with Rules, Explanations of Systems, and Use of Theodolite for Traverse Surveying and Plotting the work with minute accuracy by means of Straight Edge and Set Square only; Levelling with the Theodolite, Setting-out Curves with and without the Theodolite, Earthwork Tables, etc. By W. DAVIS HASKOLL, C.E. With numerous Woodcuts. Fifth Edition, Enlarged. Crown 8vo, cloth 12s.

TECHNICAL TERMS, ENGLISH-FRENCH, FRENCH-ENGLISH: A Pocket Glossary; with Tables suitable for the Architectural, Engineering, Manufacturing, and Nautical Professions. By JOHN JAMES FLETCHER. Fourth Edition, 200 pp. Waistcoat-pocket size, limp leather 1s. 6d.

TECHNICAL TERMS, ENGLISH-GERMAN, GERMAN-ENGLISH: A Pocket Glossary suitable for the Engineering, Manufacturing, and Mining Industries. Compiled by J. G. HORNER, A.M.I.Mech.E., Translated and Revised by ALFRED SCHLOMANN, Editor of "Illustrated Technical Dictionaries in Six Languages." Waistcoat-pocket size [Nearly Ready.]

TECHNICAL TERMS, ENGLISH-SPANISH, SPANISH-ENGLISH: A Pocket Glossary suitable for the Engineering, Manufacturing, and Mining Industries. By R. D. MONTEVERDE, B.A. (Madrid). 316 pp. Waistcoat-pocket size, limp leather. Net 2s. 6d.

TELEPHONES: THEIR CONSTRUCTION, INSTALLATION, WIRING, OPERATION AND MAINTENANCE. A Practical Reference Book and Guide for Electricians, Wiremen, Engineers, Contractors, Architects, and others interested in Standard Telephone Practice. By W. H. RADCLIFFE and H. C. CUSHING, JR. 180 pages. With 125 Illustrations. Fcap. 8vo, cloth Net 4s. 6d.

TELEPHONES: FIELD TELEPHONES FOR ARMY USE; INCLUDING AN ELEMENTARY COURSE IN ELECTRICITY AND MAGNETISM. By Lieut. E. J. STEVENS, R.A., A.M.I.E.E., Instructor, School of Signalling, Aldershot, Late Instructor in Electricity, Ordnance College, Woolwich. Second Edition, Revised and Enlarged. Crown 8vo, cloth, 138 pp. With Illustrations

[Just Published. Net 2s. 6d.]

BATTERIES—ELECTRICAL CIRCUITS—MAGNETISM—INDUCTION—MICROPHONES AND RECEIVERS—PORTABLE AND FIELD TELEPHONE SETS—SELF-INDUCTION, INDUCTIVE CAPACITY—STEVENS-LYON SIGNAL LAMP, ETC.

TELEPHONY: A COMPREHENSIVE AND DETAILED EXPOSITION OF THE THEORY AND PRACTICE OF THE TELEPHONE ART. By SAMUEL G. MCMEEN, Memb. Am. Inst. Electrical Engineers, and KEMPSTER B. MILLER, Memb. Am. Inst. Electrical Engineers. 950 pp., with 670 Illustrations. Royal 8vo, cloth.

[Just Published. Net 17s.]

*. Graphic in its treatment, this work is easy to understand, and will add to the knowledge of the experienced telephone operator. It covers the Installation, maintenance and operation of all types of telephone systems.

TELEPHONY. See also WIRELESS TELEPHONY and WIRELESS TELEGRAPHY.

THREE PHASE TRANSMISSION. See ELECTRICAL TRANSMISSION OF ENERGY.

TOOLS FOR ENGINEERS AND WOODWORKERS. Including Modern Instruments of Measurement. By JOSEPH HORNER, A.M.Inst.M.E., Author of "Pattern Making," etc. Demy 8vo, with 456 Illustrations Net 9s.

TOOTHED GEARING. A Practical Handbook for Offices and Workshops. By J. HORNER, A.M.I.M.E. Second Edition, with a New Chapter on Recent Practice. With 184 Illustrations. Crown 8vo, cloth. 6s.

TRAMWAYS: THEIR CONSTRUCTION AND WORKING. Embracing a Comprehensive History of the System; with an exhaustive Analysis of the Various Modes of Traction, including Horse Power, Steam, Cable Traction, Electric Traction, &c.; a Description of the Varieties of Rolling Stock; and ample Details of Cost and Working Expenses. New Edition, thoroughly revised, and including the Progress recently made in Tramway Construction, etc. By D. KINNEAR CLARK, M.Inst.C.E. With 400 Illustrations. 8vo, 780 pp. buckram ... 28s.

TRUSSES OF WOOD AND IRON. Practical Applications of Science in Determining the Stresses, Breaking Weights, Safe Loads, Scantlings, and Details of Construction. With Complete Working Drawings. By W. GRIFFITHS, R.I.B.A. Oblong 8vo, cloth. 4s. 6d.

TUNNELLING. A Practical Treatise. By CHARLES PRELINI, C.E. With additions by CHARLES S. HILL, C.E. With 150 Diagrams and Illustrations. Royal 8vo, cloth Net 16s.

TUNNELLING, PRACTICAL. Explaining in detail Setting-out the Works, Shaft-sinking, and Heading-driving, Ranging the Lines and Levelling underground, Sub-Excavating, Timbering and the Construction of the Brickwork of Tunnels. By F. W. SIMMS, M.Inst.C.E. Fourth Edition, Revised and Further Extended, including the most recent (1895) Examples of Sub-aqueous and other Tunnels, by D. KINNEAR CLARK, M.Inst.C.E. With 34 Folding Plates. Imperial 8vo, cloth ... £2 2s.

TUNNEL SHAFTS. A Practical and Theoretical Essay on the Construction of large Tunnel Shafts. By J. H. WATSON BUCK, M.Inst.C.E., Resident Engineer, L. and N. W. R. With Folding Plates, 8vo, cloth 12s.

WAGES TABLES. At 54, 52, 50 and 48 Hours per Week. Showing the Amounts of Wages from One quarter of an hour to Sixty-four hours, in each case at Rates of Wages advancing by One Shilling from 4s. to 55s. per week. By THOS. GARBUTT, Accountant. Square Crown 8vo, half-bound 6s.

WATER ENGINEERING. A Practical Treatise on the Measurement, Storage, Conveyance, and Utilisation of Water for the Supply of Towns, for Mill Power, and for other Purposes. By CHARLES SLAGG, A.M.Inst.C.E. Second Edition. Crown 8vo, cloth 7s. 6d.

WATER, FLOW OF. A New Theory of the Motion of Water under Pressure and in Open Conduits and its practical Application. By LOUIS SCHMER, Civil and Irrigation Engineer. 234 pages, with Illustrations. Medium 8vo, cloth Net 12s. 6d.

WATER, POWER OF. As Applied to Drive Flour Mills and to give Motion to Turbines and other Hydrostatic Engines. By JOSEPH GLYNN, F.R.S., etc. New Edition. Illustrated. Crown 8vo, cloth 2s.

WATER SUPPLY OF CITIES AND TOWNS. By WILLIAM HUMBER, A.M.Inst.C.E. and M.Inst.M.E., Author of "Cast and Wrought Iron Bridge Construction," etc., etc. Illustrated with 50 Double Plates, 1 Single Plate, Coloured Frontispiece, and upwards of 250 Woodcuts, and containing 400 pp. of Text. Imperial 4to, elegantly and substantially half-bound in morocco Net £6 6s.

LIST OF CONTENTS:—I. HISTORICAL SKETCH OF SOME OF THE MEANS THAT HAVE BEEN ADOPTED FOR THE SUPPLY OF WATER TO CITIES AND TOWNS—II. WATER AND THE FOREIGN MATTER USUALLY ASSOCIATED WITH IT.—III. RAINFALL AND EVAPORATION.—IV. SPRINGS AND THE WATER-BEARING FORMATIONS OF VARIOUS DISTRICTS.—V. MEASUREMENT AND ESTIMATION OF THE FLOW OF WATER.—VI. ON THE SELECTION OF THE SOURCE OF SUPPLY.—VII. WELLS.—VIII. RESERVOIRS.—IX. THE PURIFICATION OF WATER.—X. PUMPS.—XI. PUMPING MACHINERY.—XII. CONDUITS.—XIII. DISTRIBUTION OF WATER.—XIV. METERS, SERVICE PIPES, AND HOUSE FITTINGS.—XV. THE LAW AND ECONOMY OF WATER WORKS.—XVI. CONSTANT AND INTERMITTENT SUPPLY.—XVII. DESCRIPTION OF PLATES—APPENDICES, GIVING TABLES OF RATES OF SUPPLY, VELOCITIES, ETC., ETC., TOGETHER WITH SPECIFICATIONS OF SEVERAL WORKS ILLUSTRATED, AMONG WHICH WILL BE FOUND: ABERDEEN, BIDEFORD, CANTERBURY, DUNDEE, HALIFAX, LAMBETH, ROTHERHAM, DUBLIN, AND OTHERS.

"The most systematic and valuable work upon water supply hitherto produced in English, or in any other language. Mr. Humber's work is characterised almost throughout by an exhaustiveness much more distinctive of French and German than of English technical treatises."—*Engineer*.

WATER SUPPLY OF TOWNS AND THE CONSTRUCTION OF WATERWORKS. A Practical Treatise for the Use of Engineers and Students of Engineering. By W. K. BURTON, A.M.Inst.C.E., Consulting Engineer to the Tokyo Waterworks. Third Edition, Revised. Edited by ALLAN GREENWELL, F.G.S., A.M.Inst.C.E., with numerous Plates and Illustrations. Super-royal 8vo, buckram. 25s.

I. INTRODUCTORY.—II. DIFFERENT QUALITIES OF WATER.—III. QUANTITY OF WATER TO BE PROVIDED.—IV. ON ASCERTAINING WHETHER A PROPOSED SOURCE OF SUPPLY IS SUFFICIENT.—V. ON ESTIMATING THE STORAGE CAPACITY REQUIRED TO BE PROVIDED.—VI. CLASSIFICATION OF WATERWORKS.—VII. IMPOUNDING RESERVOIRS.—VIII. EARTHWORK DAMS.—IX. MASONRY DAMS.—X. THE PURIFICATION OF WATER.—XI. SETTLING RESERVOIRS.—XII. SAND FILTRATION.—XIII. PURIFICATION OF WATER BY ACTION OF IRON, SOFTENING OF WATER BY ACTION OF LIME, NATURAL FILTRATION.—XIV. SERVICE OR CLEAN WATER RESERVOIRS—WATER TOWERS—STAND PIPES.—XV. THE CONNECTION OF SETTLING RESERVOIRS, FILTER BEDS AND SERVICE RESERVOIRS.—XVI. PUMPING MACHINERY.—XVII. FLOW OF WATER IN CONDUITS—PIPES AND OPEN CHANNELS.—XVIII. DISTRIBUTION SYSTEMS.—XIX. SPECIAL PROVISIONS FOR THE EXTINCTION OF FIRES.—XX. PIPES FOR WATERWORKS.—XXI. PREVENTION OF WASTE OF WATER.—XXII. VARIOUS APPLIANCES USED IN CONNECTION WITH WATERWORKS.

APPENDIX I. By PROF. JOHN MILNE, F.R.S.—CONSIDERATIONS CONCERNING THE PROBABLE EFFECTS OF EARTHQUAKES ON WATERWORKS AND THE SPECIAL PRECAUTIONS TO BE TAKEN IN EARTHQUAKE COUNTRIES.

APPENDIX II. By JOHN DE RIJKE, C.E.—ON SAND DUNES AND DUNE SANDS AS A SOURCE OF WATER SUPPLY.

"We congratulate the author upon the practical commonsense shown in the preparation of this work. . . . The plates and diagrams have evidently been prepared with great care, and cannot fail to be of great assistance to the student."—*Builder*.

WATER SUPPLY, RURAL. A Practical Handbook on the Supply of Water and Construction of Water Works for small Country Districts. By ALLAN GREENWELL, A.M.Inst.C.E., and W. T. CURRY, A.M.Inst.C.E., F.G.S. With Illustrations. Second Edition, Revised. Crown 8vo, cloth 5s.

"The volume contains valuable information upon all matters connected with water supply. . . . It is full of details on points which are continually before water-works engineers."—*Nature*.

WELLS AND WELL-SINKING. By J. G. SWINDELL, A.R.I.B.A., and G. R. BURNELL, C.E. Revised Edition. Crown 8vo, cloth 2s.

WIRELESS TELEGRAPHY: ITS THEORY AND PRACTICE. A Handbook for the use of Electrical Engineers, Students, and Operators. By JAMES ERSKINE-MURRAY, D.Sc., Fellow of the Royal Society of Edinburgh, Member of the Institution of Electrical Engineers. Fourth Edition, Revised and considerably Enlarged. 450 pages, with 195 Diagrams and Illustrations. Demy 8vo, cloth.

[Just Published. Net 10s. 6d.]

ADAPTATIONS OF THE ELECTRIC CURRENT TO TELEGRAPHY—EARLIER ATTEMPTS AT WIRELESS TELEGRAPHY—APPARATUS USED IN THE PRODUCTION OF HIGH FREQUENCY CURRENTS—DETECTION OF SHORT-LIVED CURRENTS OF HIGH FREQUENCY BY MEANS OF IMPERFECT ELECTRICAL CONTACTS—DETECTION OF OSCILLATORY CURRENTS OF HIGH FREQUENCY BY THEIR EFFECTS ON MAGNETISED IRON—THERMOMETRIC DETECTORS OF OSCILLATORY CURRENTS OF HIGH FREQUENCY—ELECTROLYTIC DETECTORS AND CRYSTALLINE RECTIFIERS—THE MARCONI SYSTEM—THE LODGE-MUIRHEAD SYSTEM—THE FESSENDEN SYSTEM—THE HOZIER-BROWN SYSTEM—WIRELESS TELEGRAPHY IN ALASKA—THE DE FOREST SYSTEM—THE POULSEN SYSTEM—THE TELEFUNKEN SYSTEM—THE LEVEL AND OTHER SHOCK-EXCITATION SYSTEMS—DIRECTED SYSTEMS—SOME POINTS IN THE THEORY OF JIGS AND JIGGERS—ON THEORIES OF TRANSMISSION—WORLD-WAVE TELEGRAPHY—ADJUSTMENTS, ELECTRICAL MEASUREMENTS AND FAULT TESTING—ON THE CALCULATION OF A SYNTONIC WIRELESS TELEGRAPH STATION—TABLES AND NOTES.

“... A serious and meritorious contribution to the literature on this subject. The Author brings to bear not only great practical knowledge, gained by experience in the operation of wireless telegraph stations, but also a very sound knowledge of the principles and phenomena of physical science. His work is thoroughly scientific in its treatment, shows much originality throughout, and merits the close attention of all students of the subject.”—*Engineering*.

WIRELESS TELEPHONES AND HOW THEY WORK.

By JAMES ERSKINE MURRAY, D.Sc., F.R.S.E., M.I.E.E., Lecturer on Wireless Telegraphy and Telephony at the Northampton Institute, London; Fellow of the Physical Society of London; Author of “Wireless Telegraphy,” and Translator of Herr Ruhmer’s “Wireless Telephony.” Second Edition, Revised. 76 pages. With Illustrations and Two Plates. Crown 8vo, cloth Net 1s. 6d.

HOW WE HEAR—HISTORICAL—THE CONVERSION OF SOUND INTO ELECTRIC WAVES—WIRELESS TRANSMISSION—THE PRODUCTION OF ALTERNATING CURRENTS OF HIGH FREQUENCY—HOW THE ELECTRIC WAVES ARE RADIATED AND RECEIVED—THE RECEIVING INSTRUMENTS—DETECTORS—ACHIEVEMENTS AND EXPECTATIONS—GLOSSARY OF TECHNICAL WORDS—INDEX.

WIRELESS TELEPHONY IN THEORY AND PRACTICE. By ERNST RUHMER. Translated from the German by J. ERSKINE-MURRAY, D.Sc., M.I.E.E., etc. Author of “A Handbook of Wireless Telegraphy.” With numerous Illustrations. Demy 8vo, cloth... .. Net 10s. 6d.

“A very full descriptive account of the experimental work which has been carried out on Wireless Telephony is to be found in Professor Ruhmer’s book. . . . The volume is profusely illustrated by both photographs and drawings, and should prove a useful reference Work for those directly or indirectly interested in the subject.”—*Nature*.

“The explanations and discussions are all clear and simple, and the whole volume is a very readable record of important and interesting work.”—*Engineering*.

WORKSHOP PRACTICE. As applied to Marine, Land, and Locomotive Engines, Floating Docks, Dredging Machines, Bridges, Shipbuilding, etc. By J. G. WINTON. Fourth Edition, Illustrated. Crown 8vo, cloth 3s. 6d.

WORKS’ MANAGER’S HANDBOOK. Comprising Modern Rules, Tables, and Data. For Engineers, Millwrights, and Boiler Makers; Toolmakers, Machinists, and Metal Workers; Iron and Brass Founders, etc. By W. S. HUTTON, Civil and Mechanical Engineer, Author of “The Practical Engineer’s Handbook,” Seventh Edition, carefully Revised and Enlarged. Medium 8vo, strongly bound 15s.

STATIONARY AND LOCOMOTIVE STEAM-ENGINES, GAS PRODUCERS, GAS-ENGINES, OIL-ENGINES, ETC.—HYDRAULIC MEMORANDA: PIPES, PUMPS, WATER-POWER, ETC.—MILLWORK: SHAFTING, GEARING, PULLEYS, ETC.—STEAM BOILERS, SAFETY VALVES, FACTORY CHIMNEYS, ETC.—HEAT, WARMING, AND VENTILATION—MELTING, CUTTING, AND FINISHING METALS—ALLOYS AND CASTING—WHEEL-CUTTING, SCREW-CUTTING, ETC.—STRENGTH AND WEIGHT OF MATERIALS—WORKSHOP DATA, ETC.

PUBLICATIONS OF THE ENGINEERING STANDARDS COMMITTEE.

MESSRS. CROSBY LOCKWOOD and SON, having been appointed OFFICIAL PUBLISHERS to the ENGINEERING STANDARDS COMMITTEE, beg to invite attention to the List given below.

The Reports are Foolscap Folio, Sewed, except where otherwise stated.

Reports already published —

1. BRITISH STANDARD SECTIONS (9 lists). (*Included in No. 6.*)—
ANGLES, EQUAL AND UNEQUAL—BULB ANGLES, TEES AND PLATES—Z
AND T BARS—CHANNELS—BEAMS 1s. Net.
2. TRAMWAY RAILS AND FISH-PLATES 21s. Net.
3. REPORT ON THE INFLUENCE OF GAUGE LENGTH. By
Professor W. C. UNWIN, F.R.S. 5s. Net.
4. PROPERTIES OF STANDARD BEAMS. (*Included in No. 6.*)
Demy 8vo, sewed 1s. Net.
5. STANDARD LOCOMOTIVES FOR INDIAN RAILWAYS.
6. PROPERTIES OF BRITISH STANDARD SECTIONS. *Superseded.*
and Definitions, Tables, and Formulæ. *Demy 8vo, cloth* 2s. 6d. Net.
7. TABLES OF BRITISH STANDARD COPPER CON-
DUCTORS 5s. Net.
8. TUBULAR TRAMWAY POLES 5s. Net.
9. BULL-HEADED RAILWAY RAILS 21s. Net.
10. TABLES OF PIPE FLANGES 2s. 6d. Net.
11. FLAT-BOTTOMED RAILWAY RAILS 21s. Net.
12. SPECIFICATION FOR PORTLAND CEMENT 5s. Net.
13. STRUCTURAL STEEL FOR SHIPBUILDING 5s. Net.
14. STRUCTURAL STEEL FOR MARINE BOILERS 5s. Net.
15. STRUCTURAL STEEL FOR BRIDGES AND GENERAL BUILD-
ING CONSTRUCTION 5s. Net.
16. SPECIFICATIONS AND TABLES FOR TELEGRAPH
MATERIALS 21s. Net.
17. INTERIM REPORT ON ELECTRICAL MACHINERY
19. REPORT ON TEMPERATURE EXPERIMENTS ON FIELD *Superseded.*
COILS OF ELECTRICAL MACHINES ... 10s. 6d. Net.
20. BRITISH STANDARD SCREW THREADS ... 2s. 6d. Net.
21. BRITISH STANDARD PIPE THREADS ... 2s. 6d. Net.
22. REPORT ON EFFECT OF TEMPERATURE ON INSULATING
MATERIALS 5s. Net.
23. STANDARDS FOR TROLLEY GROOVE AND WIRE 1s. Net.
24. MATERIAL USED IN THE CONSTRUCTION OF RAILWAY
ROLLING STOCK 21s. Net.
25. ERRORS IN WORKMANSHIP. Based on Measurements carried out
for the Committee by the National Physical Laboratory 10s. 6d. Net.
26. SECOND REPORT ON STANDARD LOCOMOTIVES FOR
INDIAN RAILWAYS *Superseded.*
27. STANDARD SYSTEMS OF LIMIT GAUGES FOR RUNNING
FITS 5s. Net.
28. NUTS, BOLT-HEADS, AND SPANNERS 2s. 6d. Net.
29. INGOT STEEL FORGINGS FOR MARINE PURPOSES. 5s. Net.

PUBLICATIONS OF THE ENGINEERING STANDARDS COMMITTEE—(contd.)

30. INGOT STEEL CASTINGS FOR MARINE PURPOSES. 5s. Net.
31. STEEL CONDUITS FOR ELECTRICAL WIRING ... 5s. Net.
32. STEEL BARS (for use in Automatic Machines) ... 2s. 6d. Net.
33. CARBON FILAMENT GLOW LAMPS ... 5s. Net.
35. COPPER ALLOY BARS (for use in Automatic Machines) 2s. 6d. Net.
36. STANDARDS FOR ELECTRICAL MACHINERY. 2s. 6d. Net.
37. CONSUMERS' ELECTRIC SUPPLY METERS (Motor Type for Continuous and Single-Phase Circuits) ... 5s. Net.
38. LIMIT GAUGES FOR SCREW THREADS ... 5s. Net.
39. COMBINED REPORTS ON SCREW THREADS (containing Reports Nos. 20, 28, 38) ... 7s. 6d. Net.
40. CAST IRON SPIGOT AND SOCKET LOW PRESSURE HEATING PIPES ... 2s. 6d. Net.
41. CAST IRON SPIGOT AND SOCKET FLUE OR SMOKE PIPES ... 2s. 6d. Net.
42. RECIPROCATING STEAM ENGINES FOR ELECTRICAL PURPOSES ... 5s. Net.
43. CHARCOAL IRON LAPWELDED BOILER TUBES 2s. 6d. Net.
44. CAST IRON PIPES FOR HYDRAULIC POWER ... 5s. Net.
45. STANDARD DIMENSIONS FOR THE THREADS OF SPARKING PLUGS (FOR INTERNAL COMBUSTION ENGINES) 2s. 6d. Net.
46. KEYS AND KEYWAYS ... 2s. 6d. Net.
47. STEEL FISHPLATES FOR BULL-HEAD AND FLAT-BOTTOM RAILWAY RAILS ... 10s. 6d. Net.
48. WROUGHT IRON OF SMITHING QUALITY FOR SHIP-BUILDING (Grade D) ... 2s. 6d. Net.
49. AMMETERS AND VOLTMETERS ... 5s. Net.
50. THIRD REPORT ON STANDARD LOCOMOTIVES FOR INDIAN RAILWAYS. Incorporating Reports Nos. 5 and 26. 21s. Net.
51. WROUGHT IRON FOR USE IN RAILWAY ROLLING STOCK. "Best Yorkshire" and Grades A., B. and C. ... 10s. 6d. Net.
52. BAYONET SOCKET LAMP-HOLDERS AND CAPS ... 5s. Net.
53. COLD DRAWN WELDLESS STEEL TUBES FOR LOCOMOTIVE BOILERS ... 2s. 6d. Net.
54. THREADS, NUTS AND BOLT HEADS FOR USE IN AUTOMOBILE CONSTRUCTION ... 2s. 6d. Net.
55. HARD-DRAWN COPPER AND BRONZE WIRE 10s. 6d. Net.
56. DEFINITIONS OF YIELD POINT AND ELASTIC LIMIT. *Gratis.*
57. HEADS FOR SMALL SCREWS ... 2s. 6d. Net.
58. CAST IRON SPIGOT AND SOCKET SOIL PIPES ... 5s. Net.
59. SPIGOT AND SOCKET WASTE AND VENTILATING PIPES FOR OTHER THAN SOIL PURPOSES ... 5s. Net.
60. REPORT OF EXPERIMENTS ON TUNGSTEN FILAMENT GLOW LAMPS (in two parts) ... 21s. 0d. Net.
61. COPPER TUBES AND THEIR SCREW THREADS ... 2s. 6d. Net.

London: Crosby Lockwood & Son,
7, STATIONERS' HALL COURT, LUDGATE HILL, E.C.
and 5, Broadway, Westminster, S.W.

THE BRITISH

Telegrams: "HUMBOLDTIA, LONDON."

HUMBOLDT

Telephone: 272 Central.

ENGINEERING CO. LTD.

Dixon House, Lloyd's Avenue, London, E.C.

SO₂, NH₃, and CO₂

ICE & REFRIGERATING MACHINERY

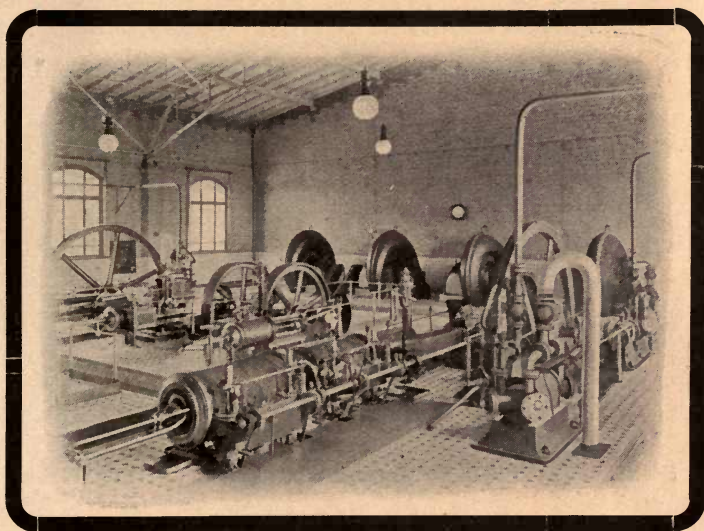

Refrigerating Machines at Cologne Municipal Abattoirs.

**COMPLETE PLANTS for any Refrigerating
Purpose on Land, Rail, or Water.**

NUMEROUS HIGHEST REFERENCES FROM PLANTS ERECTED
IN ALL PARTS OF THE WORLD.

Founded 1856.

4,000 hands employed.

UNIVERSITY OF CALIFORNIA LIBRARY
BERKELEY

Return to desk from which borrowed.
This book is DUE on the last date stamped below.

7 Apr 52 V W

10 Apr 52 LU

MAR 15 1977 5 C

REC. CIR. 7 DEC 8 '76

LD 21-95m-11,'50(2877s16)476

SEND FOR CATALOGUE, No. 109
MANUFACTURERS

The RUBEROID Co. Ltd.

81 and 83 KNIGHTRIDER ST., LONDON, E.C.
WORKS - - BRIMSDOWN, MIDDLESEX

TRADE **STANLEY** MARK

The Largest Manufacturers of
Surveying and Drawing Instruments
in the World.

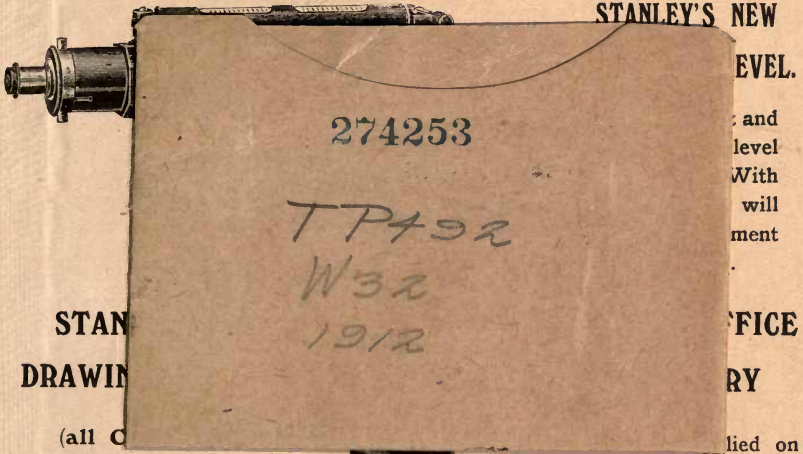

STAN
DRAWING

(all C

The result of over thirty
years' experience.

the most favourable terms.
A very large Stock kept.

Please send for our
"K57" Catalogue, and
compare our prices
with those of other
FIRST-CLASS Makers



We were awarded
Four Grands Prix
and a Gold Medal at
the Turin Exhibition,
1911.

REFRIGERATOR THERMOMETERS

a speciality. Patent Alarm Thermometers can be set to ANY temperature, and an alarm given at any distance immediately the temperature rises above that point.

W. F. STANLEY & CO. Ltd., Great Turnstile, Holborn, London, Eng.

Showrooms: 286 HIGH HOLBORN, LONDON, W.C.

