



3 1761 06704383 6



Digitized by the Internet Archive  
in 2007 with funding from  
Microsoft Corporation







PHARMACEUTICAL BOTANY

---

YOUNGKEN



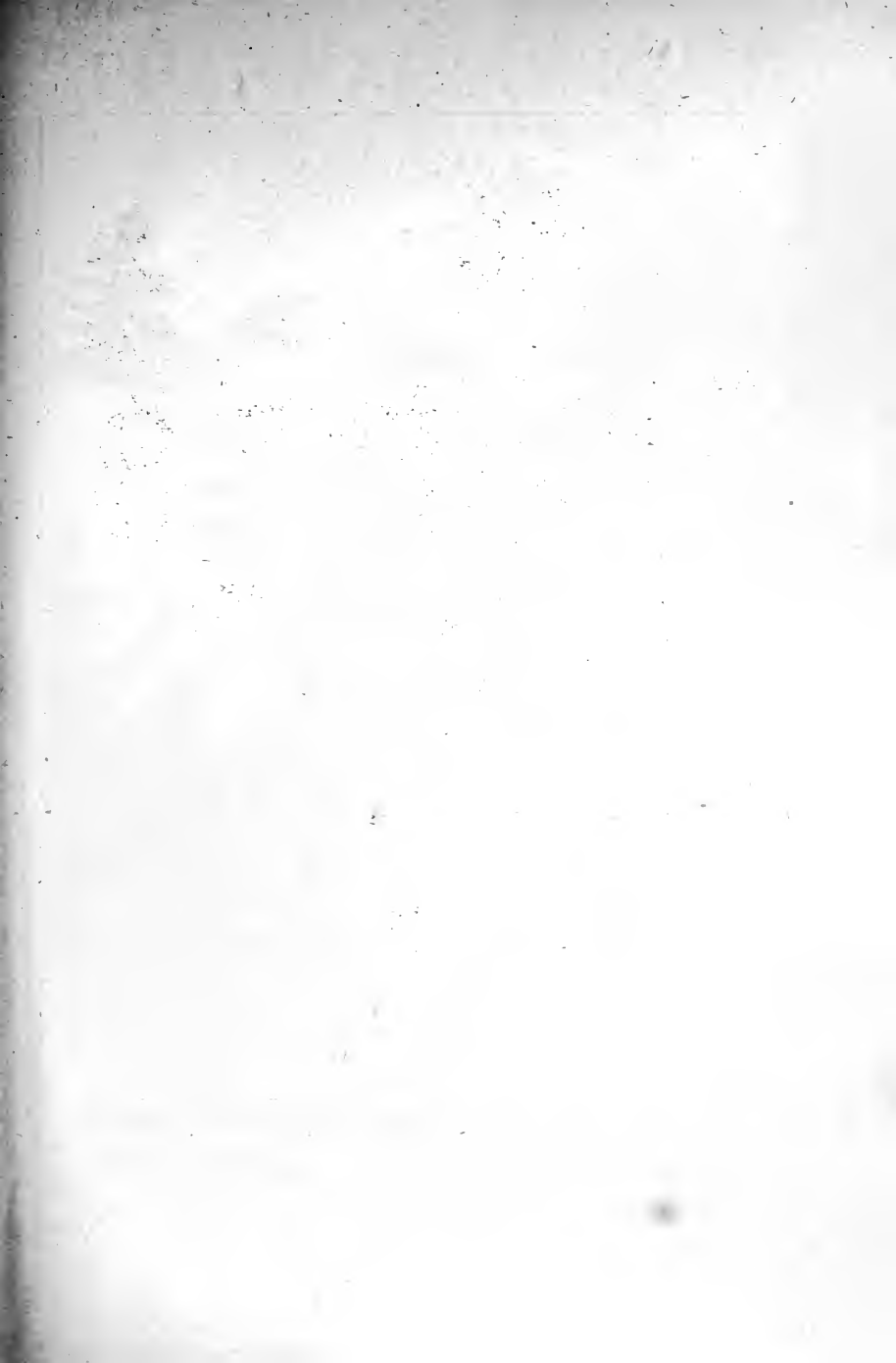



*Dryopteris marginalis*, one of the ferns whose rhizome and stipes constitute the drug, *Aspidium*.

(Frontispiece)

MPha.  
Y

# PHARMACEUTICAL BOTANY

A TEXT-BOOK FOR STUDENTS OF  
PHARMACY AND SCIENCE

BY

HEBER. W. YOUNGKEN, A.M., M.S., Ph.M., Ph.D.  
PROFESSOR OF BOTANY AND PHARMACOGNOSY AND DIRECTOR OF THE MICROSCOPICAL  
LABORATORIES IN THE PHILADELPHIA COLLEGE OF PHARMACY AND SCIENCE

177724.

26. 1. 23.

THIRD EDITION, REVISED AND ENLARGED  
WITH 238 ILLUSTRATIONS  
AND GLOSSARY OF BOTANICAL TERMS

PHILADELPHIA  
P. BLAKISTON'S SON & CO.  
1012 WALNUT STREET

1921  
1921  
1921

TM

1921

COPYRIGHT, 1921, BY P. BLAKISTON'S SON & CO.

---

"The use in this volume of certain portions of the text of the United States Pharmacopœia is by virtue of permission received from the Board of Trustees of the United States Pharmacopœial Convention. The said Board of Trustees is not responsible for any inaccuracy of quotation nor for any errors in the statement of quantities or percentage strengths."

## PREFACE TO THE THIRD EDITION

The author has first endeavored to present in a clear, systematic way those fundamental principles of structural and taxonomic botany which serve as a key to the approach of pharmacognic problems. But he has not been unmindful that the use of the work has extended to academic institutions and, so, in this edition, has broadened the scope of the former text. To this end about ninety additional pages of subject matter have been introduced. Several old cuts have been removed. Forty-three new ones have been inserted. Hypothetical discussions have been avoided which saves time for the reader.

The arrangement and plan of the chapters are similar to that of the former edition, in order to adapt the work to several methods of approach. Chapter I on "Fundamental Considerations" has been augmented by treatises on Botanical Nomenclature, Paraffine and Celloidin Imbedding, Sectioning, Staining and Mounting, Microtomes and other information dealing with the preparation of materials for microscopic examination.

Ten pages have been added to Chapter V on Cytology. Under "Protoplasm and its Properties," six pages have been written on the subject of Irritability and Irritable Reactions. Under "Non-Protoplasmic Cell Contents" several additional commercial starches are discussed and two original plates on starch grains added. Additional cuts on Collenchyma, Stone Cells, Sclerenchyma Fibers, Trichomes and Fibrovascular Bundles have been inserted in Chapter VI.

Nine additional pages of subject matter and illustrations have been added to Chapter VII. Original figures of all of the important types of fruits appear here for the first time.

Chapter VIII on "Taxonomy" has been increased by seven pages of new data, and the whole former text carefully revised.

Chapter IX on "Ecology" has been newly introduced as has also a Glossary of Botanical Terms. The index has been so planned as to make the information contained in this book readily accessible.

To the authors of works from which cuts were borrowed the writer's thanks are due.

H. W. Y.



## PREFACE TO THE SECOND EDITION

The appearance of the United States Pharmacopœia IX and the National Formulary IV, with the many changes in the lists and definitions of officially recognized vegetable drugs made it necessary to revise the former edition of this work.

In the course of revision, the writer has taken cognizance of the growing importance of Botany in the curricula of pharmaceutical institutions and has accordingly expanded upon the subject matter of the former text.

With the adoption for the first time by the new United States Pharmacopœia of pharmacognic standards for numerous drugs, Pharmacognosy has risen to the forefront in this country as a science. While its proper comprehension requires laboratory instruction in chemistry, physics, and crystallography as well as botany, nevertheless a rather extended foundation in structural botany stands out preëminently as the most needed requirement.

The work has been for the most part remodeled. Chapter I deals with Fundamental Considerations. Chapter II is devoted to the life history of the Male Fern, a median type of plant, the consideration of which, after the students have received fundamental practice in the use of the microscope, the writer has found commendable, for it not only gives beginners a working knowledge of structures and functions, the homologies and analogies of which will be met in the later study of forms of higher and lower domain, but holds their interest on account of its economic importance.

The life history of a type of Gymnosperm, White Pine, is next taken up in Chapter III. Chapter IV considers the life history of an Angiosperm as well as coördinates the resemblances and differences between Gymnosperms and Angiosperms. Chapters V, VI and VII are devoted respectively to Vegetable Cytology, Plant Tissues and Plant Organs and Organisms. Among the many additions to

the topics included in these might be mentioned a treatise on Cell Formation and Reproduction including Indirect Nuclear Division, twenty pages on Non-Protoplasmic Cell Contents, the consideration of Woods, Root Tubercles, the gross structure and histology of different types of leaves, broad histologic differences between Monocotyl and Dicotyl leaves, the histology of floral parts and the histology of types of fruits and seeds. Chapter VIII on Taxonomy has been increased by the addition of 144 pages. Several new families of drug-yielding plants have been added and the treatment of family characteristics has in the majority of instances been broadened. The habitats of drug-yielding plants have been added. In that portion of the tables dealing with the names of official drugs, those official in the National Formulary have been so designated by the abbreviation N. F., to distinguish them from others that may occur in the same portion of the table and which are official in the Pharmacopœia.

In keeping with the increased size of the book, many new illustrations have been introduced. A number of these are original drawings, photographs and photomicrographs. To the authors of other works from which cuts were borrowed, the writer's thanks are due.

The writer in conclusion desires to thank Dr. John M. Macfarlane, head of the Botanical Department of the University of Pennsylvania, for valuable suggestions during the preparation of portions of the text.

H. W. Y.

# CONTENTS

## CHAPTER I

### FUNDAMENTAL CONSIDERATIONS

|   | PAGES |
|---|-------|
| DEPARTMENTS OF BOTANICAL INQUIRY.—1. Morphology (Gross Anatomy, Histology, Cytology). 2. Physiology. 3. Taxonomy or Systematic Botany. 4. Ecology. 5. Genetics. 6. Phytopathology. 7. Phytogeography. 8. Phytopalæontology. 9. Etiology. 10. Economic Botany and its subdivisions.....  | 1-2   |
| PRINCIPLES OF CLASSIFICATION.—Natural System: species; genus; family; order; class; subdivision; division; variety; race; hybrid.....   | 2-3   |
| OUTLINE OF PLANT GROUPS.....  | 3-4   |
| BOTANICAL NOMENCLATURE.....   | 4-7   |
| THE MICROSCOPE.—Definition. The simple microscope. The dissection microscope. The compound microscope: its construction and use. The binocular microscope. Rules for the care of the microscope.....  | 7-14  |
| MAKING OF SECTIONS.—Free hand sectioning. Kinds of sections. Microtomes (hand, sliding and rotary), their construction and use.....   | 15-20 |
| THE TECHNIQUE OF MAKING A TEMPORARY MOUNT.....  | 20    |
| THE TECHNIQUE OF MAKING PERMANENT MOUNTS.—The mounting medium; Staining. Method for the Preparation of a Canada Balsam Mount. Method for the Preparation of a Glycerin-Gelatin Mount. Technique of Fixing, Dehydrating, Hardening and Imbedding in Paraffine. Technique of Sectioning and Mounting Material Imbedded in Paraffine. Method for the Staining and Mounting of Material in Paraffine Ribbons affixed to slide. Imbedding in Celloidin. Sectioning Celloidin Material. Staining and Mounting Celloidin Sections..... | 20-30 |
| DESILICIFICATION. SCHULZE'S MACERATION PROCESS..  | 30-31 |
| MICROMETRY.—Unit of microscopical measurement. Standardization of the Ocular Micrometer.....  | 31-32 |

## CHAPTER II

## LIFE HISTORY OF THE MALE FERN

|   | PAGES |
|---|-------|
| <b>HISTORY OF THE SPOROPHYTE OR ASEXUAL GENERATION.</b>   |       |
| —Gross structure of stem. Histology of mature stem. Histology of growing apex. Histology of mature root. Histology of root apex. Continuity of crude sap flow. Histology of stipe. Histology of lamina. Comparative physiology of root, stem and leaf. Gross structure and histology of the sori and sporangia. Rupture of sporangium and spore dissemination. <b>HISTORY OF THE GAMETOPHYTE OR SEXUAL GENERATION.</b> —Origin of new sporophyte or diploid plant from fertilized egg. Growth of seedling into mature sporophyte. Alternation of generations..... | 33-44 |

## CHAPTER III

## LIFE HISTORY OF A GYMNOSPERM (PINUS STROBUS)

|   |       |
|---|-------|
| <b>DESCRIPTION OF THE WHITE PINE TREE (SPOROPHYTE).</b>   |       |
| —Staminate cones. Carpellate cones. <b>DESCRIPTION OF THE GAMETOPHYTE GENERATION.</b> —The Male Gametophyte. The Female Gametophyte. Fertilization. Seed Formation and Distribution. <b>GERMINATION OF THE SEED</b> ..... | 45-52 |

## CHAPTER IV

## LIFE HISTORY OF AN ANGIOSPERM

|   |       |
|---|-------|
| <b>DESCRIPTION OF THE DOG'S TOOTH VIOLET.</b> —Development of Female Gametophyte. Maturation of the Pollen Grain and formation of the Male Gametophyte. Pollination and Fertilization. Ripening of the Ovule to form the Seed and of the Ovary to form the Fruit. Germination of the Seed and development of the Mature Sporophyte..... | 53-58 |
| <b>RESEMBLANCES BETWEEN GYMNOSPERMS AND ANGIOSPERMS</b> .....   | 58    |
| <b>FUNDAMENTAL DIFFERENCES BETWEEN GYMNOSPERMS AND ANGIOSPERMS</b> .....  | 58-59 |

## CHAPTER V

## VEGETABLE CYTOLOGY

PAGES

|   |       |
|---|-------|
| VEGETABLE CYTOLOGY.—Definition. The Plant Cell as the Fundamental Unit. A typical Plant Cell.....   | 60-61 |
| PROTOPLASM AND ITS PROPERTIES.—Structure. Metabolism. Irritability (Thermotropism, Chemotropism, Sitotropism, Hydrotropism, Heliotropism, Geotropism, Galvanotropism, Thigmotropism.) Reproduction.....   | 62-68 |
| PROTOPLASMIC CELL CONTENTS.—Cytoplasm; nucleus; nucleolus; plastids (leucoplasts, chloroplasts, chromoplasts)   | 68-70 |
| CELL FORMATION AND REPRODUCTION.—Asexual and sexual cells. Reproduction defined. Asexual Reproduction: Fission; Gemmation; Free Cell Formation; Rejuvenescence. Sexual Reproduction: Conjugation and Fertilization.....   | 70-71 |
| INDIRECT NUCLEAR DIVISION.....  | 71-74 |
| NON-PROTOPLASMIC CELL CONTENTS.—Sugars. Starch. Inulin. Hesperidin. Strophanthin. Salicin. Saponin. Coniferin. Digitoxin. Characteristics of Glucosides. Alkaloids and their properties. The alkaloids, Strychnine, Veratrine, Nicotine, Caffeine, Cocaine, Aconitine, Colchicine. Glucoalkaloids. Asparagine. Calcium Oxalate. Cystoliths. Silica. Tannins. Proteins. Aleurone Grains. Mucilages and Gums. Fixed Oils and Fats. Volatile Oils. Resins. Oleoresins. Gum Resins. Balsams. Pigments. Latex. Enzymes. Classification of Enzymes..... | 74-96 |
| CELL WALLS.—Their formation and composition. Growth in area and thickness. Various kinds of cell walls and behavior of each to micro-chemic reagents.....   | 96-98 |

## CHAPTER VI

## PLANT TISSUES

|  |        |
|--|--------|
| PLANT TISSUES.—Tissue defined. The Tissues of Spermatophytes and Pteridophytes: Generative Tissues. List of Tissues..... | 99-100 |
| MERISTEM.—Definition. Primary and secondary meristems; their distribution.....   | 100    |

|  | PAGES   |
|--|---------|
| PARENCHYMA.—Definition; ordinary parenchyma; assimilation parenchyma; conducting parenchyma; reserve parenchyma; their structure, distribution and function. . . . . | 101-103 |
| COLLENCHYMA.—Definition, function and distribution. . . . .  | 103     |
| SCLERENCHYMA.—Definition; stone cells; sclerenchyma fibers; wood fibers; bast fibers; their distribution. . . . .  | 103-106 |
| EPIDERMIS.—Definition; transpiration and water stomata; epidermal papillæ; trichomes; scales; their distribution and functions. . . . .                              | 106-109 |
| ENDODERMIS.—Definition, distribution and functions . . . . .   | 109-110 |
| CORK.—Definition; its derivation, function and distribution . . . . .  | 110     |
| LATICIFEROUS TISSUE.—The structure, origin, distribution of latex cells, laticiferous vessels and secretory cells. Latex . . . . .                                   | 110-112 |
| SIEVE (LEPTOME OR CRIBIFORM) TISSUE.—Definition; distribution; function . . . . .  | 112     |
| TRACHEARY TISSUE.—Tracheæ: Definition, function and classification; Tracheids: Definition and function. . . . .  | 112-116 |
| MEDULLARY RAYS.—Primary and Secondary; their distribution and functions . . . . .  | 116-117 |
| FIBRO-VASCULAR BUNDLES.—Definition of the various types; the distribution of each type; Xylem and Phlœm. . . . .   | 117-119 |
| SECRETION SACS.—Definition and distribution . . . . .  | 119     |
| INTERCELLULAR AIR SPACES.—Definition; schizogenous and lysigenous air spaces; their relative size. . . . .   | 119     |
| SECRETION RESERVOIRS.—Definition; structure; internal glands; secretion canals . . . . .   | 119-120 |
| CLASSIFICATION OF TISSUES ACCORDING TO FUNCTION . . . . .  | 120     |

## CHAPTER VII

## PLANT ORGANS AND ORGANISMS

|  |     |
|--|-----|
| PLANT ORGANS AND ORGANISMS.—Organ and organism defined. Vegetative Organs: Roots, stems and leaves. Reproductive Organs: Flower, fruit and seed. Embryo and its parts; function of the cotyledon . . . . . | 121 |
|--|-----|

|  | PAGES   |
|--|---------|
| THE ROOT.—Definition; functions; root hairs; root cap; generative tissues; differences between root and stem. . . . .  | 121-123 |
| CLASSIFICATION OF ROOTS AS TO FORM.—Primary root; tap root; secondary roots; fibrous and fleshy roots; anomalous roots; adventitious roots; epiphytic roots; haustoria. . . . .  | 123-124 |
| CLASSIFICATION OF PLANTS ACCORDING TO DURATION OF ROOT.—Annual; Biennial; Perennial . . . . .  | 124     |
| ROOT HISTOLOGY.—A. <i>Monocotyledons</i> . B. <i>Dicotyledons</i> ; Histology and Development of the California Privet root; Abnormal structure of Dicotyl roots; Histology of a Dicotyl Tuberos Root, <i>Aconitum</i> . . . . .   | 124-132 |
| ROOT TUBERCLES.—Definition; occurrence on roots of Leguminosæ, Myricaceæ, etc.; their etiology. . . . .  | 132-135 |
| THE BUD.—Definition; plumule, scaly buds, naked buds; Classification of Buds According to Position on Stem: terminal bud; axillary or lateral bud; adventitious bud; accessory bud. Classification of Buds According to Development: leaf bud; flower bud and mixed bud. Classification of Buds According to their Arrangement on the Stem: alternate; opposite; whorled. . . . .  | 135-136 |
| THE STEM.—Definition; direction of growth; functions; size; nodes and internodes; stem elongation; duration of stems; stem modifications; above ground stems; herb and tree defined; underground stems; exogenous and endogenous stems. . . . .  | 136-140 |
| STEM HISTOLOGY.—Annual Dicotyl; Perennial Dicotyl; Exceptional Types of Dicotyl Stems; Lenticels and Their Formation; Annual Thickening of Stems; Method of formation; "Annual Ring." Bark: Definition; zones; Periderm; Phloem; Histology of <i>Cascara Sagrada</i> bark. Wood: alburnum; duramen; microscopic characteristics of Angiospermous and Gymnospermous woods; Histology of Typical Herbaceous Monocotyl Stems; Histology of Typical Woody Monocotyl Stem . . . . . | 140-154 |
| THE LEAF.—Definition; leaf functions: photosynthesis; assimilation; respiration; transpiration . . . . .   | 155     |
| TYPES OF LEAVES DEVELOPED IN ANGIOSPERMS.—Cotyledons; Scale leaves; Foliage leaves; Bract leaves: bracts and bracteoles; Sepals; Petals; Microsporophylls; Megasporophylls   | 155-156 |

|  | PAGES   |
|--|---------|
| ORIGIN AND DEVELOPMENT OF LEAVES.—Primordial leaf.<br>Its formation . . . . .  | 156     |
| PHYLLOTAXY.—Definition; spiral law of leaf arrangement; alternate;<br>opposite, decussate; whorled; fascicled; leaf rank. . . . .  | 156-157 |
| VERNATION.—Definition; inflexed or reclinate; conduplicate; con-<br>volute; circinate; plicate; involute; revolute . . . . .   | 157-158 |
| THE COMPLETE LEAF.—Its parts; sessile; petiolate; exstipulate;<br>stipulate . . . . .  | 158-159 |
| LEAF VENATION.—Furcate; parallel; reticulate; pinni-veined;<br>palmately veined; anastomosing veins . . . . .  | 159     |
| LEAF INSERTION.—Definition; radical; cauline; ramal; perfoliate;<br>amplexicaul; connate-perfoliate; equitant . . . . .  | 159-161 |
| FORMS OF LEAVES.—Simple and Compound. (a) General Outline:<br>ovate; linear; lanceolate; elliptical; oblong; inequilateral; or-<br>bicular; peltate; filiform; oblanceolate; cuneate; spatulate; en-<br>siform; acerose; deltoid. (b) Apex: acute; acuminate; obtuse;<br>truncate; mucronate; cuspidate; aristate; emarginate; retuse;<br>obcordate. (c) Base: cordate; reniform; hastate; auriculate;<br>sagittate. (d) Margin: entire, serrate; dentate; crenate;<br>repand; sinuate; incised; runcinate; lobed; cleft; parted; di-<br>vided. Forms of Compound Leaves . . . . . | 161-166 |
| LEAF TEXTURE.—Membranous; succulent; coriaceous . . . . .  | 166     |
| LEAF COLOR.—Variations in color . . . . .  | 166     |
| LEAF SURFACE.—Glabrous; glaucous; pellucid-punctate; scabrous;<br>pubescent; villose; sericious; hispid; tomentose; spinose;<br>rugose; verrucose. . . . .   | 166     |
| DURATION OF LEAVES.—Persistent or evergreen; deciduous; cadu-<br>cous; fugacious. . . . .  | 167     |
| GROSS STRUCTURE AND HISTOLOGY OF THE LEAF PETIOLE.<br>—In Monocotyledons. In Dicotyledons. Pulvinus. Peri-<br>cladium. . . . .   | 167-168 |
| STIPULES.—Definition; lateral; free-lateral; lateral-adnate; lateral-<br>connate; lateral interpetiolar. Axillary; ochrea. Modified<br>Stipules. . . . .   | 168-169 |



|   |         |
|---|---------|
| THE LAMINA.—Definition. Mode of Development of the Lamina of Leaves: Dorsoventral; convergent; centric; bifacial; reversed; ob-dorsoventral. A. Dorsoventral: (a) Dorsoventral Umbrophytic; (b) Dorsoventral Mesophytic; (c) Dorsoventral Xerophytic; (d) Dorsoventral Hydrophytic. Gross Structure and Histology of Different Types of Dorsoventral Leaf Blades. Gross Structure and Histology of the following types: B. Convergent; C. Centric; D. Bifacial. . . . . | 169-173 |
| STRUCTURE AND DEVELOPMENT OF STOMATA . . . . .  | 173-176 |
| HISTOLOGIC DIFFERENCES BETWEEN LEAVES OF DICOTYLEDONS AND MONOCOTYLEDONS . . . . .  | 176     |
| INFLORESCENCE.—Definition; Parts of Inflorescences; Determinate; Indeterminate; Mixed Forms of Indeterminate and Determinate Inflorescences . . . . .   | 177-180 |
| PRÆFLORATION.—Convolute; involute; revolute; plicate; imbricate; valvate; vexillary; contorted. . . . .   | 180     |
| THE FLOWER.—Definition; floral parts; essential organs; complete; perfect; hermaphrodite; regular; symmetrical; imperfect; double; staminate; pistillate; neutral; connation; adnation. . . . .   | 181-183 |
| THE RECEPTACLE, TORUS OR THALAMUS.—Definition; variations in structure; anthophore; gonophore; gynophore; carpophore. . . . .   | 183     |
| THE PERIGONE.—Definition; dichlamydeous; monochlamydeous . . . . .  | 183     |
| THE CALYX.—Definition; parts; physical characteristics; connation; kinds and forms; persistence; adnation; sepaline spurs; sepaline stipules; sepaline position . . . . .   | 183-185 |
| THE COROLLA.—Definition; parts; physical characteristics; functions. Forms of the Corolla and Perianth. . . . .   | 185-188 |
| THE ANDRŒCIUM OR STAMEN SYSTEM.—Definition; parts; terms denoting number of stamens in flower; insertion of stamens; proportions of stamens; connation of stamens; stamen color. Gross Structure and Histology of the Filament. Gross Structure and Histology of the Anther. Anther Dehiscence. Development of the Anther. Attachment of Anther. Pollen: description; forms . . . . .   | 188-195 |

|   | PAGES   |
|---|---------|
| THE GYNÆCIUM OR PISTIL SYSTEM.—Definition; Gymnospermous and Angiospermous; parts; the pistil a modified leaf; carpel; dehiscence; apocarpous and syncarpous pistils; terms denoting the number of carpels entering into the formation of the pistil; compound pistils; ovules or megasori as transformed buds; position of ovules in ovary; Gymnospermous and Angiospermous ovules; structure of Angiospermous ovule; shape of ovule . . . . . | 195-197 |
| THE PLACENTA.—Definition; types of placenta arrangement . . .   | 197     |
| THE STYLE.—Definition; style-arms; relation to carpels forming the gynœcium; variations from typical styler development . . .   | 198     |
| THE STIGMA.—Definition; forms in wind- and animal-pollinated flowers; stigmatic papillæ . . . . .   | 199     |
| POLLINATION.—Definition; Close and Cross Pollination; terms applied to plants pollinated by various agencies . . . . .  | 199-200 |
| MATURATION OF THE POLLEN GRAIN AND FORMATION OF MALE GAMETOPHYTE . . . . .  | 200     |
| MATURATION OF THE EMBRYO SAC AND FORMATION OF THE FEMALE GAMETOPHYTE . . . . .  | 200     |
| FERTILIZATION IN ANGIOSPERMS.—Process; formation of embryo and endosperm . . . . .  | 200-201 |
| THE FRUIT.—Definition; modifications . . . . .  | 202     |
| FRUIT STRUCTURE.—Pericarp; pseudocarp; anthocarp; epicarp; mesocarp; endocarp; sarcocarp; putamen; sutures; valves; dehiscence . . . . .  | 202-204 |
| CLASSIFICATION OF FRUITS.—Simple; Aggregate; Multiple; dry dehiscent; dry indehiscent; fleshy indehiscent. Forms of Simple Fruits: capsular; schizocarpic; achenial; baccate; drupaceous. Etærio. Forms of Multiple Fruits; strobile or cone; sorosis; syconium; galbalus . . . . .   | 204-211 |
| HISTOLOGY OF A CAPSULE, VANILLA . . . . .   | 211-212 |
| HISTOLOGY OF A MERICARP, FŒNICULUM . . . . .  | 212-213 |
| THE SEED.—Definition; structure; functions; appendages . . . . .  | 213-214 |
| MODE OF FORMATION OF DIFFERENT TYPES OF ALBUMEN.<br>—Perispermic; endospermic; perispermic and endospermic; exalbuminous and albuminous seeds . . . . .   | 214-215 |

|  |         |
|--|---------|
| A MONOCOTYL SEED.—Its gross structure and histology. . . . . | 215-216 |
| A MONOCOTYL SEEDLING.—Germination and structure. . . . .     | 216-217 |
| A DICOTYL SEED.—Its gross structure and histology. . . . .   | 217-218 |

## CHAPTER VIII

## TAXONOMY

|   |         |
|---|---------|
| THALLOPHYTA.—Definition. Characters of the Protophyta, Myxomycetes, Algæ, Fungi and Lichenes. The Mounting and Staining of Bacteria. Life histories of representative types of Thallophytes. Plants of the group yielding drugs and economic products . . . . .   | 219-282 |
| BRYOPHYTA.—Definition. Characters of the Hepaticæ and Musci. Life history of a typical true moss . . . . .  | 282-287 |
| PTERIDOPHYTA.—Definition. Characters of the Lycopodiinæ, Equisetinæ and Filicinæ. Life history of a typical fern. Plants of the group yielding official drugs . . . . .   | 287-292 |
| SPERMATOPHYTA (PHANEROGAMIA).—Definition. Characteristics of the Gymnosperms and of the Order and Family yielding important drugs and economic products. Table of official and unofficial drugs yielded by Gymnosperms including part of plants used, botanical origins and habitats. Characteristics of the Angiosperms and of the classes and families yielding drugs. Tables of official and unofficial drugs with the names of the plants, parts constituting the drugs and habitats. . . . . | 292-407 |

## CHAPTER IX

## ECOLOGY

|  |         |
|--|---------|
| PLANT ASSOCIATIONS.—Definition. Classification based on relation plant associations have assumed in regard to water. Characteristics of Hydrophytes, Helophytes, Halophytes, Xerophytes, Mesophytes and Tropophytes. . . . . | 408-412 |
| GLOSSARY. . . . .  | 412-440 |
| INDEX. . . . .   | 441-479 |

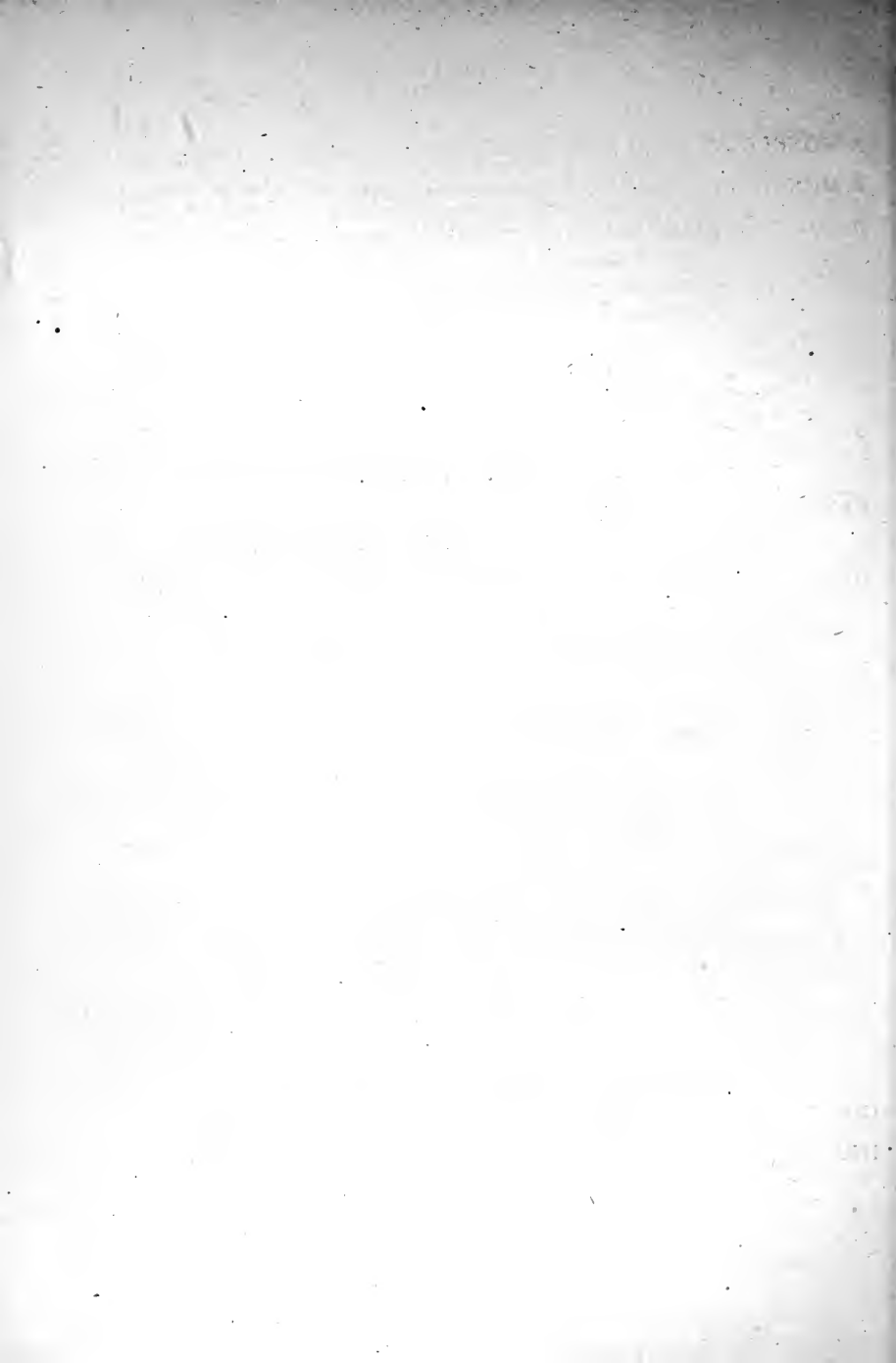

## ERRATA

- Page 18—Last word of last line, for '9' read '10'.
- Page 81—Second column, second line, for 'ellipticolar' read 'elliptical or'.
- Page 125—Second line of legend to figure, for 'rendodermis' read 'endodermis'.
- Page 130—Second line of legend to figure, for 'in Fig. 61' read 'in Fig. 62'.
- Page 138—Ninth line from bottom, for 'suffruitoose' read 'suffruticose.'
- Page 183—Thirteenth line from bottom, for 'If' read 'In'.
- Page 183—Seventh line from bottom, for '*monochalmydeous*' read '*monochlamydeous*'.
- Page 245—Second line from top, for '*archegonia*' read '*oögonium*'.
- Page 355—Fifth and sixth lines from bottom of second column, for 'Volatile' read 'Fixed'.
- Page 378—Eight line from top should be placed beneath *Apia Fructus*.
- Page 418—Tenth line from top, for 'nucleus' read 'nucellus'.



# PHARMACEUTICAL BOTANY

---

## CHAPTER I

### FUNDAMENTAL CONSIDERATIONS

#### Botany is the Science which Treats of Plants

#### DEPARTMENTS OF BOTANICAL INQUIRY

1. **Morphology** treats of the parts, or structure of plants. It is divided into:

(a) **Macromorphology** or **Gross Anatomy** which deals with the external characters of plants or their parts; (b) **Micromorphology** or **Histology** which considers the minute or microscopical structure of plants and plant tissues; and (c) **Cytology** which treats of plant cells and their contents.

2. **Physiology** deals with the study of the life processes or functions of plants. It explains how the various parts of plants perform their work of growth, reproduction, and the preparation of food for the support of animal life from substances not adapted to that use.

3. **Taxonomy** or **Systematic Botany** considers the classification or arrangement of plants in groups or ranks in accordance with their relationships to one another.

4. **Ecology** treats of plants and their parts in relation to their environment.

5. **Plant Genetics** seeks to account for the resemblances and differences which are exhibited by plants related by descent.

6. **Phytopathology** treats of diseases of plants.

7. **Phytogeography** or **Plant Geography** treats of the distribution of plants upon the earth. The center of distribution for each species of plant is the *habitat* or the original source from which it spreads, often over widely distant regions. When plants grow in their native countries they are said to be *indigenous* to those regions. When they grow in a locality other than their original home they are said to be *naturalized*.

8. **Phytopalæontology** or **Geological Botany** treats of plants of former ages of the earth's history traceable in their fossil remains.

9. **Etiology** is the study of the causes of various phenomena exhibited by plants.

10. **Economic** or **Applied Botany** deals with the science from a practical standpoint, showing the special adaptation of the vegetable kingdom to the needs of everyday life. It comprises a number of subdivisions, viz.: **Agricultural Botany**, **Horticulture**, **Forestry**, **Plant Breeding**, and **Pharmaceutical Botany**. **Pharmaceutical Botany** considers plants or their parts with reference to their use as drugs. It interlocks very closely with other departments of botanical science.

### PRINCIPLES OF CLASSIFICATION

The classification of plants is an attempt to express the exact kinship which is believed to exist among them. By grouping together those plants which are in some respects similar and combining these groups with others, it is possible to form something like an orderly system of classification. Such a system based upon natural resemblances is called a **natural system**. In a natural system of classification every individual plant belongs to a *species*, every species to a *genus*, every genus to a *family*, every family to an *order*, every order to a *class*, every class to a *division*. In many instances species may be subdivided into *varieties* or races. The crossing of two varieties or species, rarely of two genera, gives rise to a *hybrid*. Thus, the species *Papaver somniferum* which yields the opium of the Pharmacopœia belongs to the genus *Papaver*, being placed in this genus with other species which have one or more essential characteristics in common. The genera *Papaver*, *Sanguinaria* and *Chelidonium*, while differing from each other in certain essential respects, nevertheless agree in other particulars such as having latex, perfect flowers, capsular fruits, etc., and so are placed in the *Papaveraceæ* family. The *Papaveraceæ* family and the *Fumariaceæ* family are closely allied, the latter only differing from the former in having irregular petals, usually diadelphous stamens and non-oily albumen and so both of these families are placed in the order *Papaverales*. The orders *Papaverales*, *Geraniales*, *Sapindales*, *Rhamnales*, etc., are



related by a common structure namely, two seed leaves or cotyledons and so are grouped together under the class *Dicotyledoneæ*. The *Dicotyledoneæ* differ from the *Monocotyledoneæ* in that the latter group possess but one cotyledon; but both classes agree in having covered ovules and seeds, and so are placed in the subdivision *Angiospermæ*. The *Angiospermæ* differ from the *Gymnospermæ* in that the latter possess naked ovules and seeds; but both of these subdivisions agree in producing real flowers and seeds. For these reasons they are placed in the division **Spermatophyta** of the Vegetable Kingdom.

OUTLINE OF PLANT GROUPS

|                          |   |                |   |                  |
|--------------------------|---|----------------|---|------------------|
| <b>I. Thallophyta</b>    | { | 1. Protophyta  | { | Bacteria         |
|                          |   |                |   | Cyanophyceæ      |
|                          |   | 2. Myxomycetes |   | Acrasiales       |
|                          |   |                |   | Phycomyxales     |
|                          |   |                |   | Myxogastrales    |
| <b>II. Bryophyta</b>     | { | 3. Algæ        | { | Chlorophyceæ     |
|                          |   |                |   | Phæophyceæ       |
|                          |   |                |   | Rhodophyceæ      |
|                          |   | 4. Fungi       | { | Phycomycetes     |
|                          |   |                |   | Ascomycetes      |
| <b>III. Pteridophyta</b> | { | 5. Lichenes    | { | Basidiomycetes   |
|                          |   |                |   | Fungi Imperfecti |
|                          |   |                |   | Crustaceous      |
|                          |   |                |   | Foliaceous       |
|                          |   |                |   | Fruticose        |
| <b>IV. Bryophyta</b>     | { | 1. Hepaticæ    | { | Marchantiales    |
|                          |   |                |   | Jungermanniales  |
| <b>V. Bryophyta</b>      | { | 2. Musci       | { | Anthocerotales   |
|                          |   |                |   | Sphagnales       |
| <b>VI. Pteridophyta</b>  | { | 1. Lycopodineæ | { | Andrææales       |
|                          |   |                |   | Bryales          |
|                          |   |                |   | Lycopodialès     |
|                          |   | 2. Equisetineæ | { | Selaginales      |
|                          |   |                |   | Isoetales        |
| 3. Filicineæ             | { | Equisetales    |   |                  |
|                          |   | Ophioglossales |   |                  |
|                          |   | Filicales      |   |                  |

|                   |                |                 |
|-------------------|----------------|-----------------|
| IV. Spermatophyta | 1. Gymnospermæ | Cycadales       |
|                   |                | Ginkgoales      |
|                   | 2. Angiospermæ | Coniferales     |
|                   |                | Gnetales        |
|                   |                | Monocotyledoneæ |
|                   |                | Dicotyledoneæ   |

### BOTANICAL NOMENCLATURE

Before Carl von Linné, (Linnaeus) the great Swedish naturalist, brought forth the binomial plan of nomenclature, no uniformity existed in the assignment of plant names. Among the pre-Linnean botanists there were some who designated plants by single names, others who employed sentences in naming them, some of which were quite lengthy, and a number who adhered to the practice of naming them in their own modern tongue. The result was quite obvious, a number of systems were employed and confusion prevailed among students. According to the binomial plan which has been universally adopted, every plant belongs to a species which is given two Latin names. The first name is the name of the genus or generic name, the second, the name of the species or specific name. The generic name corresponds, in the naming of persons, to the surname or family name, while the specific name is analogous to the given name. Thus, the Wild Cherry is named *Prunus serotina*, *Prunus* representing the name of the genus, *serotina* the specific name or kind of *Prunus*. The name of the genus (pl. genera) is always a substantive in the singular number and must not be applied to more than one genus. Its spelling should begin with a capital letter. Genera names may be taken from any source whatever. Some, like *Fagus* for the Beech genus, and *Acer* for the Maple, are of Latin origin. Others have been latinized from other languages. Some have been named after some therapeutic property, their roots, leaves, flowers or seeds were thought to possess; for example, *Jateorhiza*, a latinized compound of two greek words, *ιάτεια*, healing, + *ρίζα*, root, because of the healing virtues of the root. A number have had names ascribed to them because of some peculiarity of structure, color, taste, odor, behavior, habit or appearance of the plant or portion thereof.

Thus, *Eriodictyon* (from Gr. ἔριον, wool + δίκτυον, net) alludes to its woolly, netted veined leaves; *Melaleuca* (from Gr. μέλας, black, + λευκός, white) alludes to the black bark of the trunk and white bark of the branches; *Marrubium* (from Hebrew *marrob*, bitter) refers to its bitter sap; *Barosma* (from Gr. βαρύς, heavy + οσμή, odor) in allusion to its strong smell; *Epiphegus* (from Gr. ἐπί, upon, + φηγός, the beech) alludes to its growth on the roots of that tree; *Impatiens* (from Lat. *in*, not and *patiens*, enduring) refers to the sudden bursting of the capsules of this genus when touched; *Lycopodium* (from Gr. λύκος, a wolf, + πούς, a foot) pertains to the appearance of the shoots of this genus. Many have been named in honor of eminent naturalists or friends of these, or other noted persons. For example, *Collinsonia* was named in honor of Peter Collinson, an English botanist of the 18th century; *Dioscorea* in honor of Dioscorides, the Greek naturalist; *Paullinia* after Paullini, a German botanist of the 17th century; *Cinchona* in honor of the countess of Chinchon, who brought the bark to Europe in 1640 and *Jeffersonia*, in honor of Thomas Jefferson.

The specific names are for the most part adjectives which agree with the names of genera to which they belong in case, gender, etc. They may, however, be nouns and in a few instances consist of two nouns or a noun and an adjective. If an adjective it should begin with a small letter, as in *Rhus glabra* and *Euonymus atropurpureus*. When the specific name is a noun, it may either be a proper noun in the genitive case when it should begin with a capital, as *Garcinia Hanburyi*; or it may be a common noun in the genitive, when it should begin with a small letter, as *Grindelia camporum*; or the noun may be in apposition to the generic name and so in the same case, as *Cytisus scoparius*. Names that had formerly been used for genera but since reduced to species are always capitalized, whether originally proper nouns or not, as *Aristolochia Serpentaria* and *Anacyclus Pyrethrum*. In cases where two nouns make up the specific name, the first of these is in the nominative case, the second in the genitive, the two names being connected by a hyphen, as *Capsella bursa-pastoris*. The botanical name of the species yielding the drug, *Aspidosperma*, (*Aspidosperma Quebracho-blanco*) will serve as an example of the specific portion of the names being composed of a noun and an ad-

jective. Specific names taken from names of persons should always begin with a capital.

Names of varieties are applied in three different ways. Either the name of the species is given and followed by the prefix *var.* before the varietal name, as *Chenopodium ambrosioides* var. *anthelminticum*; or the varietal name may be appended to the name of the species, as *Chenopodium ambrosioides anthelminticum*; or the varietal name may be placed immediately after the name of the genus and the specific name dropped, as *Chenopodium anthelminticum*.

It frequently happens that a botanist is careless in naming a species, and, without ascertaining whether the same name has been assigned to another species, applies it to his, thus causing duplication. For example, there are two distinct species of plants named *Prunus virginiana*, one of these, the Wild Black Cherry, the other, the Choke Cherry. In this instance the name *Prunus virginiana* does not tell us which species the writer or speaker refers to. It might be the Choke Cherry named "*Prunus virginiana*" by Linnaeus or the Wild Black Cherry named "*Prunus virginiana*" by Miller at a later date. Accordingly, it is necessary to add to the name of the species the author's name. Thus, *Prunus virginiana* Linné refers to the Choke Cherry while *Prunus virginiana* Miller refers to the Wild Black Cherry. In this connection it is customary to abbreviate the name of the author thus, L. for Linné, Mill. for Miller, Ait. for Aiton, Loisel. for Loiseleur-Deslongchamps, or Tourn. for Tournefort.

Whenever a plant is transferred from one genus to another, it must retain its original specific name, unless the genus to which it is transferred already possesses a species with that name, in which case a new specific name must be given it. Moreover, the name of the botanist who assigned the original specific name but placed it under a different genus must be placed in parenthesis between the specific name and the name of the botanist who later connects it with another genus. For example, we read as the official definition for Purging Cassia in the National Formulary IV—"The dried fruit of *Cathartocarpus Fistula* (Linné) Persoon." The significance of the name Linné in parenthesis is that he had previously given the specific name *Fistula* to the plant indicated but placed it under a different genus, which genus happened to be *Cassia*. Therefore Persoon,

in connecting it up with another genus *Carthartocarpus*, avoided binomial duplication by interjecting Linné parenthetically between his name and the specific name *Fistula*.

The names of families are designated by the name of one of their principal genera or ancient generic names with the ending *aceae*, e.g., *Ranunculaceae* from *Ranunculus*, *Malvaceae* from *Malva*, etc. The following names, because of long usage, are exceptions to the rule: *Palmae*, *Gramineae*, *Guttiferae*, *Umbelliferae*, *Labiatae*, and *Compositae*.

Orders are generally designated by the name of one of their principal families, with the ending *ales*, e.g., *Rhamnales* from *Rhamnaceae*, *Rosales* from *Rosaceae*. Suborders are likewise designated, but with the ending—*inae*, e.g., *Malvinae* from *Malvaceae*. Other older endings may, however, be retained for these names providing they do not lead to confusion or error.

Names of classes, subclasses, divisions and subdivisions are designated from one of their characters by words of Latin or Greek origin, some similarity of form and ending being given to those that designate groups of the same nature, as *Monocotyledoneae*, *Dicotyledoneae*; *Archichlamydeae*, *Metachlamydeae*; *Thallophyta*, *Spermatophyta*; *Gymnospermae*; *Angiospermae*.

In the case of Cryptogams the use of old family names as *Algae*, *Fungi*, *Lichens*, *Musci*, etc. is permissible for designating groups above the rank of family.

## THE MICROSCOPE

A microscope is an optical instrument, consisting of a lens, or combination of lenses, for making an enlarged image of an object which is too minute to be viewed by the naked eye.

Microscopes are of two kinds, viz.: simple and compound.

### THE SIMPLE MICROSCOPE

This consists simply of a convex lens or several combined into a system and appropriately mounted. A good example of a simple microscope is a reading glass. This type of simple microscope is valuable in field work, in the examination of dried herbarium material or the external characters of crude drugs, where only a low magnification of the object is required.

But when flowers or other plant parts are to be dissected, it is necessary to have both hands free. To meet this need various forms of stands have been devised which have been combined with an arm and lens to constitute what are known as "Dissecting Microscopes." One of the simpler forms of these is shown in Figs. 1 and 2. It consists of a low wooden stand with inclined sides that furnish convenient hand rests for the operator. In the center of



FIG. 1.—Front view of a dissecting microscope. Description in text.

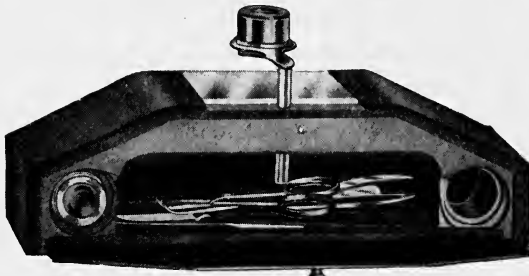

FIG. 2.—Rear view of same.

the upper surface of the stand is a glass plate on which the object to be dissected is placed. Beneath this a mirror is set which reflects light to the object. On either side of the mirror is a hollow cut out which permits light to strike the mirror from various angles. A lens arm fits in an aperture just behind the center of the glass plate. The carrier on the end of the horizontal portion of this accommodates the magnifier. The arm can be moved up and down or from side to side in securing a focus. The rear of the block is hollowed out, providing a convenient receptacle for dissecting tools.

## THE COMPOUND MICROSCOPE

A. *Its Construction:*

The principal parts of a compound microscope are:

1. The *base*, generally horseshoe shaped, which rests on the table.
2. The *pillar*, an upright bar, which is attached to the base below and supports the rest of the instrument.
3. The *stage*, a horizontal shelf upon which is placed the preparation or slide to be examined. The stage is perforated in the center for transmitting light reflected up by the mirror. On the stage are two clips for holding the glass slide.

4. The *mirror*, situated below the stage, by which the light is reflected upward through the opening in the stage.

5. The *diaphragm*, inserted in the opening of the stage or attached to its lower face, and used to regulate the amount of light reflected by the mirror.

6. The *body tube*, a cylinder which holds the *draw tube* and *lenses* and moves up and down perpendicularly above the opening in the stage. The tube is raised or lowered either by sliding it back and forth with a twisting movement or by a *rack and pinion* mechanism. The latter is called the *coarse adjustment*.

7. The *fine adjustment*, a micrometer screw back of the tube, which, on being turned, produces a very small motion of the entire framework which holds the body tube.

8. The *oculars* or *eyepieces* which slip into the upper end of the *draw tube*. Each of these consist of two plano-convex lenses, the lower one being the larger and known as the *field lens* because it increases the field of vision. The upper or smaller lens is called the *eye lens*. It magnifies the image formed by the objective. Midway between the field and eye lens is a *perforated diaphragm*, the object of which is to cut out edge rays from the image.

According to the system adopted by the maker, oculars are designated by numbers, as 1, 2, 3, 4, etc., or by figures which represent focal lengths.

9. The *objectives*, which screw into the bottom of the body tube or nose piece. They consist of a system of two, three or four lenses, some of which are simple, others compounded of a convex crown lens and a concave flint lens. Objectives like oculars are usually

designated by numbers or by figures, as  $\frac{1}{12}$ ,  $\frac{1}{6}$ ,  $\frac{2}{3}$ , etc., or in millimeters, as 2 mm., 4 mm., 16 mm., which represent focal lengths.

The smaller the number or fraction representing the focal length of an objective, the greater is its magnifying power.

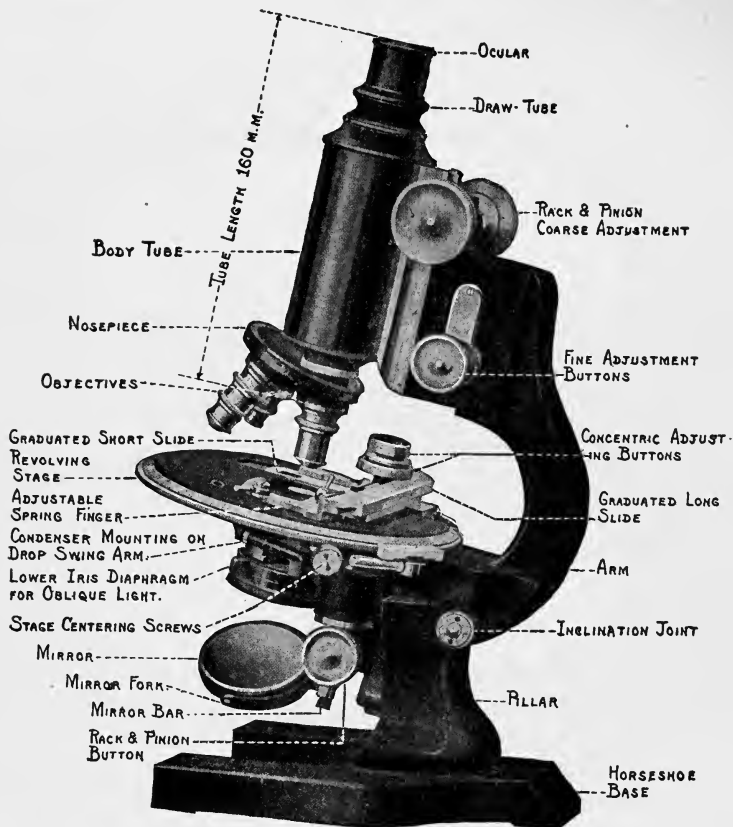

FIG. 3.—Illustrating the parts of a compound microscope.

Objectives are either *dry* lenses or *immersion* lenses. If an air space be present between the objective and the object, the lens is called a *dry* one; if a liquid is present between the objective and the object, the lens is called an *immersion* lens. If this liquid be oil,



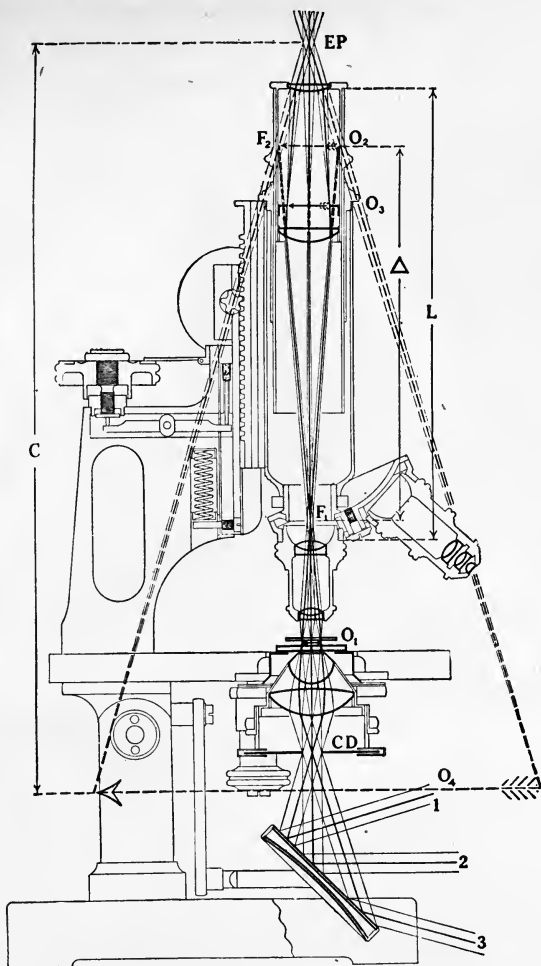

FIG. 4.—Diagram illustrating optics of a compound microscope in use.  $F_1$ , Upper focal plane of objective;  $F_2$ , Lower focal plane of eyepiece;  $\Delta$ , Optical tube length = distance between  $F_1$  and  $F_2$ ;  $O_1$ , object;  $O_2$ , real image in  $F_2$ , transposed by the collective lens, to  $O_3$ , real image in eyepiece diaphragm;  $O_4$ , virtual image formed at the projection distance  $C$ , 250 mm. from EP, eyepoint; CD, condenser diaphragm;  $L$ , mechanical tube length (160 mm.); 1, 2, 3, three pencils of parallel light coming from different points of a distant illuminant, for instance, a white cloud, which illuminate three different points of the object. (Courtesy of Bausch and Lomb Optical Co.)

the objective is called an *oil immersion objective*; if water, a *water immersion objective*.

Some microscopes are fitted up with a *nose piece*, capable of carrying two or three objectives, which may be revolved into place at the



FIG. 5.



FIG. 6.

FIG. 5.—Microscope lamp useful in illuminating opaque objects.

FIG. 6.—Compound microscope with binocular body, designed to relieve eyestrain for those spending many hours with the microscope. Each ocular inclines at an angle of 4 degrees from the perpendicular, which results in their converging to a point about 17 inches from eyes having the average pupillary separation. Adjustment for pupillary distance is accomplished by turning a knurled ring on the right hand ocular tube which gives a horizontal sliding movement of the oculars. The knurled ring on the left hand ocular tube provides a means of focusing one eyepiece independently of the other. (*Made by Spencer Lens Co.*)

lower end of the body tube. Others have a *condenser* which is employed to concentrate the light upon the object examined.

#### B. *Its use:*

1. Place the microscope on the table with the pillar nearest you.
2. Screw the objectives into the nose piece and slip an ocular into the upper end, if not already on instrument. Turn the lowest power objective into position.

3. Find the light by looking into the ocular (eye piece) and at the same time turning the mirror at such an angle that it reflects light from the window or lamp up through the opening in the stage to the objective. When opaque objects are to be illuminated, a stronger illumination is required than that usually afforded by an ordinary laboratory lamp or by the light from a window. For this purpose a microscope lamp, such as the Spencer no. 374 (see Fig. 5) is very satisfactory. Mirrors have two faces, a plane and a concave. Use the concave unless employing the condenser, when the plane mirror should always be used.

4. Regulate the quantity of light by the diaphragm. If too bright it must be cut off somewhat. The higher powers require brighter light than the lower.

5. Place the slide on the stage in a horizontal position with the object over the middle of the opening through which light is thrown from the mirror.

6. With the lower power in position, move the coarse adjustment until either the object or small solid particles on the slide appear distinctly, which means that the lenses are *in focus*. The object, if not under the lens, may now be brought into the field by moving the slide back and forth very slowly while looking through the ocular. To improve the focus, slowly turn the fine adjustment screw.

7. To focus with the high-power objective, first find the object with the low power and arrange in the center of the field. Put clips on slide without moving it. Raise the body tube by means of the coarse adjustment. Then turn the high-power objective into position. (If two objectives only accompany your instrument, the high-power is the longer one.) Lower the body tube carrying the objective until the objective front lens nearly touches the cover glass. A slight movement of the fine adjustment should show the object clearly. Never focus down with the high-power objective while looking through the ocular because of the danger of pressing it into the cover glass and ruining the delicately mounted lenses.

8. Accustom yourself to use both eyes indifferently and always keep both eyes open. If right handed, observe with the left eye, as it is more convenient in making drawings.

9. When the *oil immersion objective* is to be used, a small drop of

immersion oil (slightly evaporated cedar oil) should be placed on the cover glass directly above the object and the body tube should be run down with the coarse adjustment until the front lens of the immersion objective enters the drop and comes almost into contact with the cover glass. This should be done while watching the objective. Then look through the ocular and draw the objective up with the fine adjustment until the object comes into focus.

#### RULES FOR THE CARE OF THE MICROSCOPE

1. In carrying the microscope to or from your table, grasp it firmly by the pillar and hold in an erect position, so that the ocular which is fitted loosely into the draw tube may not fall out and its lenses become damaged.

2. Never allow the objective to touch the cover glass or the liquid in which the object is mounted.

3. Never touch the objective or ocular lenses with fingers or cloths.

4. Never change from lower to higher power objective without first ascertaining that the body tube has been raised sufficiently to allow the high power objective to be slipped into place without injury to the objective or mounts.

5. Never clean the microscope lenses or stand with cloths that have been used for removing surplus of alkali, acid or other reagent from slides.

6. Note whether the front lens of the objective is clean before attempting to use it. If soiled, breathe on the lens and gently wipe with an old, clean, soft handkerchief or lens paper. If the lens be soiled with balsam or some other sticky substance, moisten the handkerchief or lens paper with a drop of xylol, taking care to wipe it perfectly dry as soon as possible.

7. Do not let the objective remain long near corrosive liquids, such as strong solutions of iodine, corrosive sublimate, or mineral acids. Never examine objects lying in such fluids without putting on a cover glass.

8. Never lift the slide from the stage, but, after raising the objective, slide it off the stage without upward movement.

9. Never allow the *stand* (microscope without lenses) to be wetted with such substances as alcohol, soap, etc., which dissolve lacquer.

10. Keep the microscope covered when not in use.

### MAKING OF SECTIONS

*Free-hand Sectioning.*—Free-hand sections are usually satisfactory for the general examination of roots, stems, leaves, barks and many fruits and seeds. Material which is fresh may be sectioned at once, but dry material should be well soaked in warm water before using. Very hard material like heartwoods, the shells of nuts and seeds, may be softened in solution of caustic potash or ammonia water and then washed free of alkali before sectioning.

The object to be sectioned is held between the thumb and finger of the left hand. If tender and flexible, such as a flat leaf, it must be placed between the two flat surfaces of elder pith before sectioning. A segment of pith about an inch long is halved lengthwise with a sharp knife and a portion of the leaf is held between the halves of pith while the section is cut through pith and leaf. The pith is later separated from the leaf section. Sections through other delicate parts of plants may be made in the same way, only a groove should be made in the pith of such size as is necessary to hold the material firmly enough without crushing it. In certain instances, when, because of the smallness of the object and its resistance to cutting, good sections can not readily be made with the aid of pith, a small sized cork stopper can be used with better results. A hole just large enough to prevent the object from slipping is made in the center of the smaller end and the object inserted preparatory to sectioning. The upper surface of the razor is wetted with water or 50 per cent. alcohol. The razor, which should be real sharp, is held in the right hand and is drawn across the object with the edge toward the student and the blade sliding on the forefinger of the left hand. The sections should be cut as thin as possible. As soon as a number of sections have been cut, they can be transferred to a vessel of water with a camel's hair brush.

*Sectioning in Paraffine or Celloidin.*—When it is necessary to study the microscopic structure of very delicate plant parts, superior results can generally be obtained by imbedding the material in paraffine or celloidin, which is subsequently hardened, and sectioned by means of a sliding or rotary microtome.

## KINDS OF SECTIONS

1. A *transverse* or *cross-section* is one made horizontally through the object, hence its plane lies at right angles to the long axis.

2. A *radial-longitudinal* section is one which is made parallel to the long axis of the object in such a way that it lies in plane of the radius.

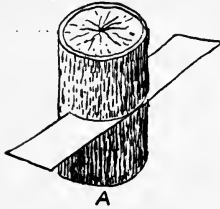

3. A *tangential-longitudinal* section is one made parallel to a plane tangent to the cylinder. This type of section is therefore prepared by cutting parallel to the outer long surface.

## MICROTOMES

Microtomes are instruments employed to facilitate the cutting of sections of organic tissues. The three most commonly used types are the hand, sliding and rotary microtomes.

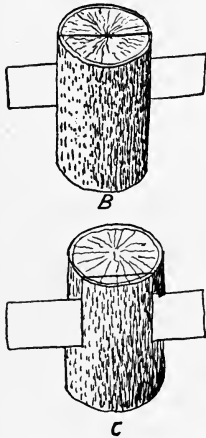

FIG. 7.—Showing the planes in which sections are cut, A, transversely; B, longitudinal radially; C, longitudinal tangentially. (After Stevens.)

*Hand Microtome.*—This type is shown in Fig. 8. If the object is sufficiently hard to bear the strain, it is placed directly in a clamp at the upper end of the tube that is tightened by the screw seen on the side of the tube, or it may first be inclosed in elder pith or cork and then clamped in. The object to be sectioned is raised a little at a time through the hole in the glass plate at the top by turning the finely graduated feed near the base of the tube. The section razor is then laid flat on the glass plate and pulled across the object with a long sliding motion.

The upper surface of the razor blade is kept wet with 50 per cent. alcohol and after several sections have been cut they can be swept by the finger or camels hair pencil to a dish of water. Each division of the feed represents 10 microns, so that the thickness of sections desired can be regulated by moving the feed, accordingly, just before each stroke of the razor.

*Sliding Microtome.*—This type of microtome (see Fig. 9) is adapted for cutting all kinds of sections. It consists of an iron supporting frame of horizontal and upright portions. The horizontal base rests on the table and is hollowed out to accommodate a drip pan that can readily be removed and cleaned.

The front of the upright portion exhibits a frame which accommodates a sliding feed mechanism to which is attached the object carrier. The top of the upright portion shows a V shaped bed which carries a solid iron block which can be readily slid along the bed when the latter is lubricated with paraffin oil. The upper surface of the block is grooved to accommodate the thumb screw. The microtome knife consists of a blade



FIG. 8.—Hand microtome. Description in text.

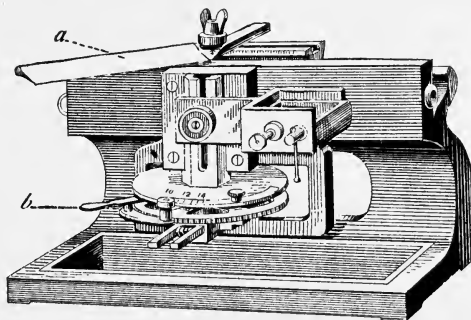

FIG. 9.—A sliding microtome. Blade (a); lever (b). (From McJunkin.)

portion, that is flat on its lower and hollow ground on its upper face, and a forked handle. The latter is slid into the stem of the thumb screw which has previously been slid into the groove of the block and its position adjusted. Sections of woody material can be cut directly on this microtome and placed in dilute alcohol. When paraffine sections are cut, the cutting edge of the knife should be parallel to the motion but when celloidin sections are desired the knife must be set at an oblique angle to the frame and drawn across the block with a long sliding motion. The knife

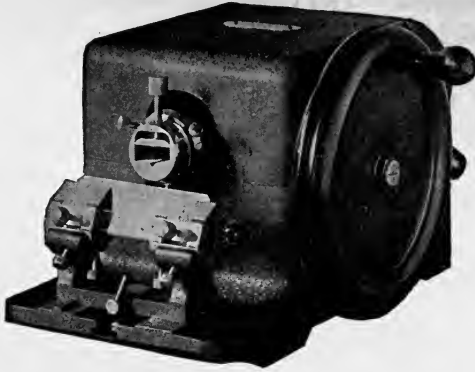

FIG. 10.—Rotary microtome. The feed mechanism is covered to protect the wearing parts from dust.

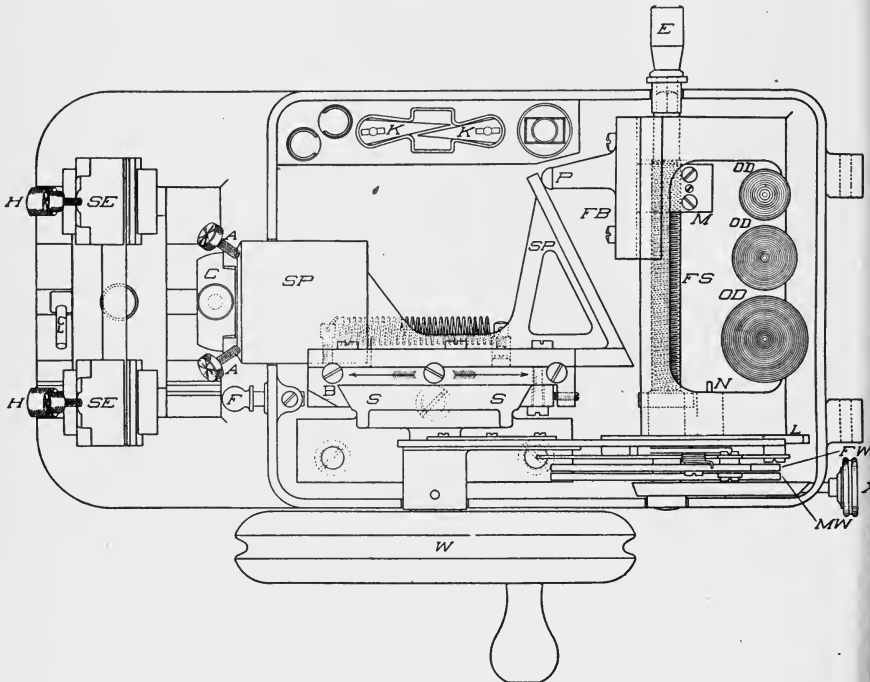

FIG. 11.—Plan of construction of rotary microtome shown in Fig. 9.



and the top of the celloidin block must be constantly kept wet with 80 per cent. alcohol.

The object is placed in the object carrier and clamped in. By means of the graduated disk at the base of the feed mechanism the thickness, in terms of microns, is regulated after each stroke of the razor.

*Rotary Microtome.*—When paraffin ribbons are desired, especially for the study of serial sections of material, the rotary microtome surpasses by far the efficiency of the sliding type of instrument. The Spencer Rotary Microtome No. 820 is shown in Fig. 10 and its plan of construction illustrated in Fig. 11. In this instrument the sliding part which carries the object clamp (SP) is carried up and down by the block (B). The feed mechanism consists of a rigid bearing, on which the feed block (FB) (of which the projection P is a part), is moved by the feed screw (FS). As this block travels toward the side on which the balance wheel (W) is located, the sliding part (SP) is forced forward towards the knife one-half as much. The polished surface set against the point (P) is arranged at the proper angle to accomplish this end. The screw, cut with two threads to the millimeter, is revolved by a ratchet feed wheel with 250 teeth. Each tooth represents a forward movement of the object of one micron. The feed can be set for sections from 1 micron to 60 microns thick, by turning the button at the back of the case until the number, representing the desired thickness, appears opposite the indicator at the small opening in the side of the case near the balance wheel. The total excursion of the feed is 37 mm. This allows a sufficient range for cutting a complete series of sections of a large object without the necessity of a break due to resetting the knife and feed mechanism. The object, after being placed in the object clamp, may be oriented to any desired angle. The clamp is held at its upper limit for orienting or trimming the block by pushing in the pin (F.) The whole knife support may readily be adjusted to and from the object, and is readily clamped in any location by a lever connected with an eccentric cam. The knife is fastened by two clamps and may be turned to any desired angle. The clamps can also be moved toward each other to bring them as near to the ribbon as desired to gain additional rigidity. The groove in the balance wheel is de-

signed for a cord or strap when it is desired to run the instrument by a motor.

### THE TECHNIQUE OF MAKING A TEMPORARY MOUNT

1. Place a drop or two of water (or reagent) in the center of a clean glass slide.

2. With the aid of a forceps take the section or very small quantity of the material to be examined and spread it on the drop of water.

3. Place a clean cover-glass over the material. In placing the cover-glass do not drop it flat upon the drop of water, but place one side of it down first and allow it to squeeze the water along under it.

4. Keep the top of the cover-glass dry.

When filamentous algæ or molds are to be examined, the material tends to cling together and must be carefully separated, in the drop of water, with dissection needles before the cover glass is placed over the material. In case a coarse ground drug is to be mounted the coarser particles should be first crushed in the water on the slide and subsequently teased apart with dissection needles.

Care should always be taken to see that the water or mounting medium used is not contaminated with foreign substances. This can best be practiced by examining the mounting medium under the microscope before the material to be examined is placed in it.

### THE TECHNIQUE OF MAKING PERMANENT MOUNTS

1. *The Mounting Medium.*—When a microscopic object is to be preserved permanently it must be kept from decaying and the fluid in which it is placed must be kept from evaporating. These conditions can be met by adding an antiseptic (2 per cent. acetic acid, or formaldehyde) to the water used in mounting and carefully sealing the cover glass with asphaltum or zinc white. As a rule, a better way is to use a mounting medium that will not evaporate, e.g., glycerine, glycerin gelatin or Canada balsam. These fluids have a high refractive index and so render the objects penetrated by them more transparent. This quality is generally an advantage, but for objects already almost transparent it is quite the reverse. Glycerine has the disadvantage of always remaining soft, so that the mount may at any time be spoiled by careless handling. Glycerin-gelatin

has the advantage of mixing readily with 50 per cent. glycerin in which the object should be placed before being mounted in this medium. It should be warmed on a water bath before using and the cover glass applied quickly after it is placed on the specimen. It cools rapidly and constitutes the quickest and simplest means of effecting a durable permanent mount. Its disadvantage is due mainly to its jelly like consistency which is frequently responsible for damaged mounts when the cover glass above the preparation is too greatly strained. Canada balsam, slowly becomes solid, so that the mount is exposed to no accident short of actual breakage. Balsam has the disadvantage of being non-miscible with water, so that before it can be used the object must be carefully dehydrated. Even after this is done, and the object lying in absolute alcohol, an oil must be used as an intermediate agent between alcohol and balsam.

2. *Staining*.—For two reasons it is generally better to stain plant tissues before mounting. Transparent tissues may become almost invisible in glycerine, glycerin-gelatin, or balsam, and different tissues take a stain differently. This being the case it becomes possible to stain one tissue and not another, or one tissue with one stain and another in the same section with a different stain, so that the different parts may be brought out like areas on a colored map. The most common stains are hæmatoxylin derived from logwood, and various anilin stains—safranin, fuchsin, eosin, iodine green, methyl-green, malachite green, etc.

#### METHOD FOR THE PREPARATION OF A CANADA BALSAM MOUNT

1. Stain object with 0.5 per cent. solution of safranin or fuchsin in 50 per cent. alcohol for from three to five minutes.
2. Wash out excess of stain and further dehydrate with 70 per cent. alcohol.
3. Stain with 0.5 per cent. solution of methyl-green, or malachite green, or iodine-green in 70 per cent. alcohol for twenty seconds or longer, depending upon the nature of the material.
4. Dehydrate and wash out excess of stain with 95 per cent. alcohol for two minutes.

5. Further dehydrate by placing material in absolute alcohol for one minute.

6. Clear in cedar oil for 1 minute. Blot up excess from around edge of section.

7. Mount in Canada balsam.

8. Label slide.

Should air-bubbles be detected in the balsam shortly after mounting, heat a dissection needle in a flame and touch each with its tip, when they will be found to disappear.

If too much Canada balsam has been used, some of it usually spreads beyond the edge of the cover-glass, or on its surface. In this event wait until the balsam hardens, when it can be scratched off with a knife, and the surface of the glass cleaned with a rag moistened with turpentine oil or xylol.

Should the Canada balsam become too thick, it can be thinned down with either xylol or benzol.

#### METHOD FOR THE PREPARATION OF A GLYCERIN-GELATIN MOUNT

1. Stain object with an aqueous solution of eosin.

2. Wash out excess of stain by moving the section about in a dish of water.

3. Transfer object to weak glycerin (glycerin 10 parts, water 90 parts) for 3 to 5 minutes.

4. Transfer object to 50 per cent. glycerin for 3 to 5 minutes.

5. Transfer object to concentrated glycerin for 5 minutes.

6. Remove excess of glycerin around object and mount in glycerin-gelatin. The slide and cover slip should be warmed before the glycerin-gelatin is dropped over the object and the cover slip quickly lowered. The preparation of Glycerin-Gelatin is as follows: Macerate 14 grams of gelatin in 84 mls of water for 2 hours, add 76 mls of glycerin and warm; add 2 mls of liquefied phenol, warm and stir for 15 minutes until clear. Filter while hot through glass-wool or filter paper and collect the filtrate in a wide mouthed bottle. Keep well stoppered so as to exclude dust.

Glycerin-Gelatin becomes solid when cool. For use warm the bottle in a water bath after first removing the stopper. A glass rod

sufficiently long to reach to the bottom of the bottle can be inserted in the cork and used for transferring the material to the slide.

7. Ring mount with zinc white or asphaltum at the edge of cover slip. If the cover slip is circular, this can best be done by means of a centering turn-table. A camel's hair brush is dipped into the zinc white or asphaltum and held to the margin of the cover slip while the slide fastened with clips to the turn table, is rotated with it.

#### 8. Label slide.

*If the objects or sections are such as not to be liable to shrink they can be transferred from water directly to glycerin-gelatin.*

### TECHNIQUE OF FIXING, DEHYDRATING, HARDENING AND IMBEDDING IN PARAFFIN

When the intention is to study the protoplasts in their natural form or the processes of cell division, the fresh material must be put through the various stages of fixation, hardening and imbedding before it is sectioned. The steps will now be considered in the order in which they must be carried out.

*Fixation.*—This is the process of killing and coagulating the protoplast. The essence of good fixation is in rapid killing. It should be simultaneous with coagulation or hardening so that the protoplast will not be modified by later treatment. Fixing fluids are always substances unknown to protoplasm *e.g.* poisons. The coagulation of protoplasmic structures is due to the fact that these are alkaline in reaction whereas the fixing fluid is acid. Fixing fluids must be judged not only as to killing and hardening but also as to reaction of tissues to stains afterward. Fluids that are mixtures make the best fixing agents. Among the fixing agents employed are the following: Osmic acid ( $\text{OsO}_4$ ) comes in sealed glass tubes containing 0.5 gm. or 1 gm. It has a very powerful odor and is easily affected by organic materials. It is used in 1 to 2 per cent. solutions and should be made up in distilled water. It fixes cytoplasm well but the nucleus not as good. Its disadvantage lies in its inability to penetrate rapidly.

Chromic acid ( $\text{CrO}_3$ ) in 0.5 to 1 per cent. aqueous solution is very favorable for nuclear structure but like osmic acid penetrates rather slowly. Picric acid  $\text{C}_6\text{H}_2(\text{OH})(\text{NO}_2)_3$  is one of the most penetrating

fixing fluids but has very little hardening power. It is employed in saturated aqueous solution.

Corrosive sublimate ( $\text{HgCl}_2$ ) in 0.2 per cent. aqueous or alcoholic solution penetrates and hardens rapidly but doesn't give as sharp optical differentiation as the others considered.

Absolute alcohol can be employed for very small objects that are dry. If the objects are moist shrinkage will follow.

Carnoy fluid; consisting of 6 parts absolute alcohol, 3 parts formaldehyde and 1 part of glacial acetic acid, can also be used for fixing small objects. It has the advantage of fixing these in about 10 minutes. Moreover the objects can be carried directly to absolute alcohol, thence to Paraffin and imbedded.

For most materials the Flemming fluids have proven very satisfactory and are the most generally employed. They are of two classes, viz; 1. Those that simply involve chromic acid and acetic acid (the chrome-acetic fluids) and 2. Those that involve chromic acid, acetic acid and osmic acid (the Chrome-Osmium-Acetic Fluids). The formulæ follow:

#### CHROME-ACETIC FLUIDS

|        |   |  |          |
|--------|---|--|----------|
| Strong | { | 1 per cent. Chromic acid solution..... | 100 mils |
|        |   | Glacial acetic acid.....               | 1 mil    |
| Medium | { | 1 per cent. Chromic acid solution..... | 70 mils  |
|        |   | 1 per cent. Glacial acetic acid.....   | 1 mil    |
|        |   | Distilled water.....                   | 29 mils  |
| Weak   | { | 1 per cent. Chromic acid solution..... | 25 mils  |
|        |   | 1 per cent. Glacial acetic acid.....   | 10 mils  |
|        |   | Distilled water.....                   | 65 mils  |

#### CHROME-OSMIUM-ACETIC FLUIDS

|        |   |  |         |
|--------|---|--|---------|
| Strong | { | 1 per cent. Chromic acid solution..... | 75 mils |
|        |   | 2 per cent. Osmic acid solution.....   | 20 mils |
|        |   | Glacial acetic acid.....               | 5 mils  |
| Weak   | { | 1 per cent. Chromic acid solution..... | 25 mils |
|        |   | 1 per cent. Osmic acid solution.....   | 10 mils |
|        |   | 1 per cent. Acetic acid solution.....  | 10 mils |
|        |   | Distilled water.....                   | 55 mils |

The acetic acid in all of the Flemming fluids is of great advantage since it penetrates very rapidly, carrying the chromic acid or chromic and osmic acids into the tissue depths, thus insuring complete fixation.

The material to be fixed should be cut into small pieces not longer than 5 mm. nor broader than 2 or 3 mm. The amount of fixation to be used should not be less than 15 times the bulk of the material to be fixed. The material should be placed in the fixing fluid immediately after it is gathered. One or two drachm homeopathic phials are convenient for the process. The material is kept in the fixing fluid for from 12 to 24 hours and then washed in small cheese cloth bags which are placed in running tap water for from 6 to 12 hours or over night.

**Dehydrating and Hardening.**—After washing the material, still kept in the bags, is placed in 10 per cent. alcohol for 1 hour and is then carried through a series of alcohols. Each of the series 10 per cent stronger than the one before it, remaining in each grade for  $1\frac{1}{2}$  to 2 hours until 70 per cent. alcohol is reached. Take out of bag and place in phial in 70 per cent. alcohol. If the material is not to be imbedded in paraffine immediately, it can remain in 70 per cent. or 85 per cent. alcohol (if very delicate) until needed. It is not safe to leave very valuable material in a grade below 70 per cent. over night. From the 70 per cent. alcohol it is carried to 85 per cent. to 95 per cent. to absolute alcohol, remaining in each at least 6 hours with 2 or 3 changes of the last.

**Clearing and Imbedding.**—In order to get the material from absolute alcohol into paraffine, some medium must be used which mixes with absolute alcohol and which also dissolves paraffine. Either oils such as cedar, clove or bergamot or substances like xylol, chloroform or benzol satisfy this requirement. To clear with xylol—transfer material from absolute alcohol to a mixture of  $\frac{3}{4}$  absolute alcohol and  $\frac{1}{4}$  xylol for 12 hours, then to mixture of equal parts of absolute alcohol and xylol for 12 hours, then to  $\frac{3}{4}$  xylol and  $\frac{1}{4}$  absolute alcohol for 12 hours to pure xylol for 12 hours. To phial containing material in pure xylol add paraffine in small pieces and put on top of paraffine bath sufficiently long until paraffine is melted. Then add more paraffine and put phial in paraffine bath at  $56^{\circ}\text{C}$ . over night.

Pour fluid off and add pure melted paraffine and repeat 2 or 3 times until rid of all trace of xylol. A tray is then prepared by taking a piece of paper and folding up its edges all around to the height of about a half inch. Half fill this on a cool surface with melted paraffine. Heat two dissection needles in bunsen flame and with these dispose pieces of material in orderly fashion over the crust which has by this time formed at the bottom of the tray. Blow upon the surface of the paraffine to harden it more quickly and as soon as the surface crust will bear it, plunge the tray into cold water. The material can now be left imbedded in paraffine until required for sectioning.

If cutting is to be done in a cool room, softer grades of paraffine with melting points between  $40^{\circ}$  and  $50^{\circ}\text{C}$ . should be used for imbedding. If on the other hand cutting is to be done at summer temperatures, the harder grades melting at between  $55^{\circ}$  and  $70^{\circ}\text{C}$ . should be employed.

#### TECHNIQUE OF SECTIONING AND MOUNTING MATERIAL IMBEDDED IN PARAFFINE

Strip off the paper tray from the imbedded material and cut out a block of paraffine containing the object which is to be sectioned, taking care to include at least 2 or 3 mm. of paraffine on all sides beyond the specimen. Take a segment of pine wood about an inch long and with a surface at one end about  $\frac{3}{8}$  in. square and coat the square area with melted paraffine. Warm the paraffine on the piece of pine wood and quickly press the paraffine block containing the specimen into this melted paraffine in the desired position for cutting. Heat a dissecting needle and apply this all around the base so that the paraffine block is firmly sealed to the wood. Dip paraffine block in cold water to harden. Now trim the paraffine block with a sharp scalpel so that the faces form right angles with each other. Adjust the wood in the clamp of the microtome and the microtome blade so that the top of the paraffine block just touches the near surface of the microtome knife. Make certain that the knife edge and the two opposite faces of the paraffine block are perfectly parallel. Now trim the remaining two sides of the block close to the object. Adjust the automatic feed of the rotary microtome by moving dial to num-



ber on scale representing thickness in microns desired of sections and turn wheel of microtome. It will be observed that the carrier moves up and down and with each downward movement slightly forward, causing the knife to cut sections which adhere in ribbons.

Transfer the ribbons by means of a camel's hair pencil or dissecting needle to a piece of dust free paper with the side downward which was next to the knife. The ribbons are now ready to be mounted on slides.

The slides to be used should only be those which are devoid of grease or dirt of any kind particularly on the surface upon which the ribbons are to be mounted. A very good plan is to keep a number of slides intended for this purpose submerged in a saturated solution of potassium dichromate in concentrated sulphuric acid. These can be taken out as needed and thoroughly rinsed with water.

With a clean cloth stretched over the forefinger vigorously rub one surface of each slide until perfectly dry and free of lint. Then place a small drop of Mayer's albumin fixative on clean surface and rub over the surface. (The formula for Mayer's Albumin Fixative is as follows: Egg white and Glycerin, equal parts, Carbolic acid 1 or 2 drops. Mix thoroughly.) Now flood the surface with water and cut the ribbons into segments of the desired length and arrange in rows on slide, being careful to have the segments somewhat shorter than the length of the cover slip because of tendency of paraffine to stretch when warmed. Warm slide gently by holding high above a bunsen flame or flame of an alcohol lamp until ribbons stretch out in smooth fashion. Absorb superfluous water from beneath ribbons with blotting paper held to their edges and at same time push the sections into even rows. Then leave the sections to dry for several hours or over night.

#### METHOD FOR THE STAINING AND MOUNTING OF MATERIAL IN PARAFFINE RIBBONS AFFIXED TO SLIDE

1. Gently heat the dry slides with paraffine ribbons adhering to the fixative, high above the Bunsen flame (with the ribbon side up).
2. Place the slide upright in a well of xylol or turpentine. The xylol or turpentine will dissolve the melted paraffine in a minute or two.

3. Take the slide out of the well, wipe off the under side and allow a stream of 95 per cent. alcohol to run over the upper side from a pipette.

4. Place the slide upright in a well of safranin for from four to twenty-four hours.

5. Take the slide out of the safranin well and extract excess of stain with 57 per cent. alcohol.

6. Place the slide in a well of gentian violet or methyl-green for a second or more. The time varies for different objects and can only be determined by trial.

7. Rinse slide with 70 per cent. alcohol from pipette.

8. Pour absolute alcohol over sections, follow with a few drops of clove oil, replace clove oil with cedar oil.

9. Mount in balsam.

10. Label slide.

#### IMBEDDING IN CELLOIDIN

Whenever material is unsuited for free hand sectioning and will not give good results when imbedded in paraffine on account of size, hardness, or brittleness, celloidin may be resorted to as an imbedding medium.

The technique employed is similar to that of the paraffine method so far as the preliminary fixing, hardening and dehydrating are concerned up to and including the 95 per cent. alcohol stage. From this point the various succeeding steps in the procedure are as follows:

1. Place material in equal parts of 95 per cent. alcohol and ether (known as ether-alcohol) for several hours.

2. Transfer to a 2 per cent. solution of celloidin in ether-alcohol, for 2-5 days.

3. Transfer to a 6 per cent. solution of celloidin in ether-alcohol, for 2-5 days.

4. Transfer to a 12 per cent. solution of celloidin in ether-alcohol, for 3-10 days.

5. Prepare a pine block sufficiently large in cross section to support the material and otherwise adapted to its being clamped in the object carrier of the microtome. Soak one end of this block in

ether-alcohol for a while and then dip it in the 2 per cent. celloidin solution.

6. Take the material from the thick celloidin and set it in proper position, for cutting the sections desired, on the prepared end of the block and allow the celloidin to thicken for a few seconds only.

7. Dip the celloidin end into the thick solution; remove and hold upright so that the new coating may spread out over the end of the block and solidify the union.

8. As soon as the celloidin has hardened a little to form a surface film, drop the preparation into a vessel of chloroform and allow to remain here 1 day.

9. Transfer preparation to a vessel containing equal parts of glycerin and 95 per cent. alcohol until required for sectioning.

#### SECTIONING CELLOIDIN MATERIAL

Clamp the block in the sliding microtome and set the knife obliquely so that the sections can be cut with a long sliding stroke. Keep the knife and top of the block wet with the alcohol-glycerin mixture and as soon as the sections are cut, sweep them with a camels hair pencil into a dish of 70 per cent. alcohol. The sections can be attached to a slide by placing the slide in a closed chamber over ether. The ether vapor dissolves the celloidin and causes the sections to adhere to the slide.

#### STAINING AND MOUNTING CELLOIDIN SECTIONS

1. Place sections in safranin solution for 1 day. This safranin solution should be made by dissolving as much safranin in 95 per cent. alcohol as it will take up and then diluting with an equal quantity of water.

2. Rinse sections in 50 per cent. alcohol to remove excess of stain.

3. Transfer them to Delafield's hæmatoxylin (made by dissolving 1 gram of hæmatoxylin in 6 mls of absolute alcohol and adding this gradually to 100 mls of a saturated aqueous solution of ammonia alum. This is left exposed for a week, filtered, 25 mls each of methyl alcohol and glycerin added, allowed to stand 6 hours, again filtered, and ripened about 2 months before using) for 10 minutes.

3. Rinse sections thoroughly first in water, then in 35 per cent. alcohol, then in 50 per cent. alcohol.
4. Put them quickly through acid alcohol (1 drop of HCl in 50 mls of 70 per cent alcohol).
5. Transfer to 70 per cent. alcohol for about 2 minutes.
6. Transfer to 85 per cent. alcohol for about 2 minutes.
7. Transfer to 95 per cent. alcohol for about 2 minutes.
8. Transfer to absolute alcohol for about 2 minutes.
9. Clear sections in a mixture of equal parts of cedar oil and phenol for at least 2 minutes.
10. Remove excess of clearing solution and mount in balsam.
11. Label slide.

#### DESILICIFICATION OF HARD WOODY MATERIALS

It frequently happens, even after prolonged maceration or boiling in alkaline solutions, that thin sections of hard roots, stems, woods or fruits are difficult or impossible to procure. This is due to the presence of deposits of silica and other mineral substances that usually occur in woody tissues. Therefore, it is of prime importance that these substances be removed as thoroughly as possible. For this purpose a 10 per cent. aqueous solution of commercial Hydrofluoric Acid (or stronger solutions up to the pure acid for very hard materials) is most useful. Small fruits or short segments of other hard materials are placed in this acid (which should be kept in a bottle coated internally with a thick layer of paraffine) for from 3 days to a week, depending on the size of the objects, with one or two changes of the acid. The acid is then washed out thoroughly with running water for 2 to 5 hours. This treatment completely frees the tissues of all mineral deposits without affecting the organic structure.

#### SCHULZE'S MACERATION PROCESS

This method is employed for the separation of cells. Radial-longitudinal sections, that may be cut with a pen knife, are placed in a beaker or test tube containing 50 mls of nitric acid of specific gravity 1.3 (about 2 volumes of nitric acid and 1 volume of water will serve purpose). To this add 1 gram of chlorate of potash crystals and heat gently until the reddish color which first appears

in the tissues has disappeared. Stop the action by pouring the whole of the contents into a vessel containing water and wash well with water. The cells can now be readily separated with dissection needles and mounted in water for examination. Do not mount in glycerine, for it makes the already bleached elements too transparent.

### MICROMETRY

The unit of length used in microscopic measurement is the *micron* ( $\mu$ ) which is one-thousandth part of a millimeter (0.001 mm.) or one twenty-five thousandth part of an inch.

In measuring microscopic objects it is necessary to make use of a micrometer of some kind. That pretty generally used is the *ocular micrometer*. It is a circle of glass suitable for insertion within the ocular with a scale etched on its surface. The scale is divided to tenths of a millimeter (0.1 mm.) or the entire surface of the glass may be etched with squares (0.1 mm.), the net micrometer.

### STANDARDIZATION OF OCULAR MICROMETER

The value of each division of the *ocular micrometer scale* must be ascertained for each optical combination (ocular, objective, and tube length) by the aid of a stage micrometer.

The *stage micrometer* is a slide with a scale engraved on it divided to hundredths of a millimeter (0.01 mm.), in some cases to tenths of a millimeter (0.1 mm.), every tenth line being made longer than intervening ones, to facilitate counting.

#### METHOD:

1. Insert the ocular micrometer within the tube of the ocular by placing it on the diaphragm of the ocular, and adjust the stage micrometer by placing it on the stage of the microscope.

2. Focus the scale of the stage micrometer accurately so that the lines of the two micrometers will appear in the same plane. Make the lines on the two micrometers parallel each other. This can often be done by turning the ocular to the right or left while looking into the microscope.

3. Make two of the lines on the ocular micrometer coincide with two on the stage micrometer. Note the number of included divisions.

4. Note the known value for each division of the stage micrometer scale which may either be etched on the stage micrometer or indicated on a label found pasted upon it. If the value indicated is 0.01 mm. ( $\frac{1}{100}$  mm.) then each division of the stage micrometer scale has a value of 10 microns; if 0.1 mm. ( $\frac{1}{10}$  mm.), 100 microns.

5. Multiply the number of included divisions of the stage micrometer scale by the value in microns given for each division and divide the result by the number of included divisions of the ocular micrometer scale. The quotient represents the value of each division of the ocular micrometer scale.

6. Note the optical combination (number of ocular, objective and tube length) used and keep a record of it with the calculated micrometer value. Repeat for each of the combinations.

To measure an object by this method read off the number of divisions it occupies of the ocular micrometer scale, and express the result in microns by looking up the recorded value for the optical combination used.

## CHAPTER II

### LIFE HISTORY OF THE MALE FERN [DRYOPTERIS (ASPIDIUM OR NEPHRODIUM) FILIX-MAS]

The Male Fern along with the Marginal Fern (*Dryopteris marginalis*) have long been known to the pharmaceutical and medical professions as the source of the drug **Aspidium**, a most valuable remedy for the expulsion of tapeworm. The parts of these plants employed are the rhizome and stipes which are collected in autumn, freed of the roots and dead portions and dried at a temperature not exceeding 70°C.

#### HISTORY OF THE SPOROPHYTE OR ASEXUAL GENERATION

**Gross Structure of Stem.**—The main axis of *Dryopteris Filix-mas* is the creeping underground stem or *rhizome* which is oblique or ascending in habit. It gives off numerous *roots* from its lower and posterior portions and *fronds* from its upper and anterior portions. Behind the fronds of the present year are to be noted the persistent stalk bases of fronds of previous seasons. *Lateral buds* are frequently to be noted connected with these. The roots are slender and brown with semi-transparent apices. They are inserted on the bases of the fronds, close to their junction with the stem. The growing end of the rhizome is called the anterior extremity and is marked by the presence of an *apical bud* overarched by young fronds. The opposite end is known as the posterior extremity and in the living plant is constantly decaying, as the anterior portion elongates.

**Histology of Mature Stem (Rhizome).**—Passing from periphery toward the center the following structures are to be observed:

1. **Epidermis**, a protective outer covering tissue, composed of a single layer of brownish polyhedral cells from which are given off scaly hairs.

2. **Outer Cortex** (hypodermis), a zone of several layers of thick-walled lignified cells separating the epidermis from the inner cortex beneath. Its main function is to support the epidermis.

3. **Inner cortex** of several layers of more or less isodiametric cells (cells of nearly the same length, breadth and thickness) with thin cellulose walls and containing stored starch surrounded by a proto-

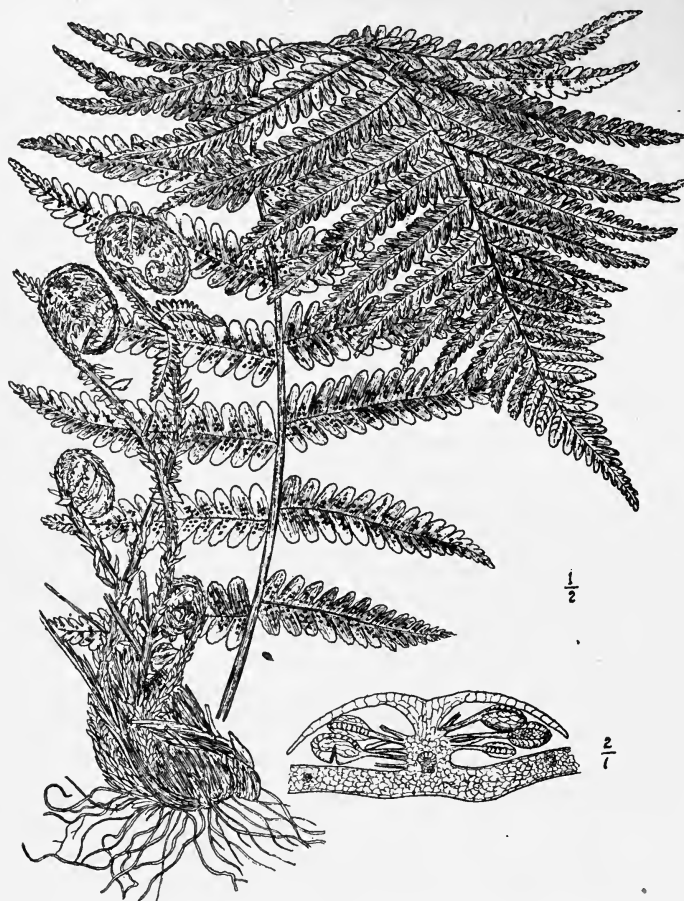

FIG. 12.—*Dryopteris filix-mas*—Plant and section through pinnule and sorus.  
(Sayre.)

plasmic investment. These cells conduct sap by osmosis and store food. Between the cells are to be noted intercellular-air-spaces, many of which contain internal glandular hairs.



4. **Fundamental tissue**, resembling the last in aspect and function.

5. **Vascular Bundles**.—These are of two kinds, viz.: stem bundles and leaf-trace bundles. Both are of elliptical outline, as seen in cross section, and are embedded in the parenchyma forming the broad central matrix. The stem bundles are comparatively broad and, as viewed in longitudinal sections, form a continuous network with good-sized meshes, each mesh being opposite the point of insertion of one of the leaves (See Fig. 13).

In transverse section these bundles are seen to be usually ten in number and arranged in an interrupted circle within the fundamental tissue. The leaf-trace bundles are comparatively narrow and are observed to come off of the stem-bundles and pass out through the cortex into the leaves (fronds).

When each bundle is examined under a high-power magnification it is seen to be composed of: (a) an *endodermis* or *bundle sheath*, a single layer of cells with yellowish walls and granular contents; (b) a *pericambium* or phloem sheath of one to three layers of delicate thin-walled cells, rich in protoplasm; (c) a *phloem*, a broad zone of tissue formed of *phloem* cells, with thin cellulose walls and protoplasmic contents, which convey sugar in solution from the leaves to the roots and broader *sieve tubes* which appear polygonal in transverse section and whose function is that of conveying soluble proteins in the same direction; (d) a *xylem* (wood) formed of thin-walled *xylem cells* which store food and *scalariform tubes* or *tracheids* which conduct crude sap (water with mineral salts in solution) from the roots to the leaves (fronds). Since the xylem is surrounded by the phloem, the fibro-vascular bundle is of the *concentric* type. Strictly speaking the endodermis and pericambium are accessory regions, surrounding, but not part of the bundle proper.

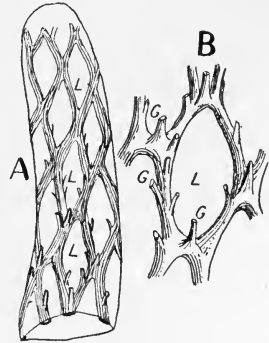

FIG. 13.—A. Cylindrical network of vascular bundles in the stem of *Dryopteris Filix-mas*. B. A portion of the same more highly magnified. At L are the interstices over which the leaves are inserted; at G are branches (leaf trace bundles) passing into the leaves from the main vascular bundles. (Sayre.)

**Histology of Growing Apex.**—When the bases of the leaves of the current year, the circinate leaves of the following year and the large mass of brown scales have been removed from around the apical bud of a well-grown plant, the following structures may readily be observed with a hand lens:

1. The **apical cone** (*punctum vegetationis*), a rounded papilla, which occupies a terminal position in the apical region.

2. The **young fronds**, arranged around the apical cone.

Upon removing the extreme apex of the apical cone with a sharp razor, mounting in dilute glycerine or water and examining under

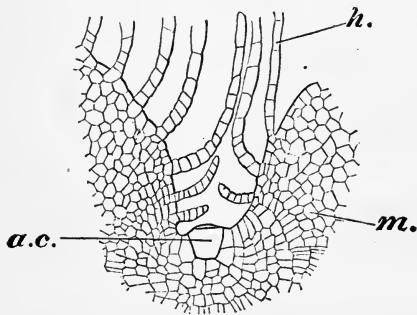

FIG. 14.—Apical cell of a fern rhizome in vertical longitudinal section. *a.c.*, apical cell; *h.*, hair; *m.*, meristem. (After Hofmeister.) Sedgwick & Wilson's *General Biology*, Henry Holt & Co.

low power, it will be noted that a large pyramidal cell occupies the center of the apical cone. This is the *apical cell* (Fig. 14). The cells surrounding it have been derived by segmentation (cell-division) from it, by means of walls parallel to its three sides; they are termed *segment cells* and in turn undergo further division and redivision to originate the entire stem tissue and leaf tissue. Step

by step the tissue cells become modified into epidermal, cortical, bundle and fundamental cells.

**Histology of Mature Root.**—Transverse sections cut some distance above the apex will present the following structures for examination:

1. **Epidermis**, of epidermal cells whose outer walls are brown. Some of these cells have grown out as root hairs which surround soil particles and absorb water with mineral salts in solution.

2. **Cortex**, of many layers of cortical parenchyma cells with brown walls. The outer layers of cells of this region are thin-walled, while the extreme inner ones are lignified and form a sclerenchymatous ring which surrounds the

3. **Endodermis**, a single layer of cells tangentially-elongated.
4. **Pericambium** (Pericycle), usually of two layers of thin-walled cells containing protoplasm and large nuclei. This region surrounds the
5. **Radial fibro-vascular bundle**, consisting of two phloem patches of phloem cells and sieve tubes on either side of two radial xylem arms of xylem cells, spiral tracheæ and scalariform tubes.
6. **Lateral rootlets**, which take origin in the pericambium.

**Histology of Root Apex.**—Microscopic examination shows this region to be composed of soft, pale, growing cells ending in the triangular *apex-cell* of the root. From the free base of the apex cell *segment cells* are cut off as *calyptragen* cells. These by dividing form the *root cap*. The root cap or *calyptra* consists of a mass of loosely attached cells which forms a protective covering around the tip of the root.

From the inner sloping sides of the apex cell the segment cells give origin to the *dermatogen*, which by repeated division of its cells, originates the *epidermis* (outer protective covering of the root), the *periblem*, originating *cortex* and the *plerome* originating the *bundle and related tissue*.

**Continuity of Crude Sap Flow.**—The *crude sap* (water with mineral salts in solution) penetrates the thin walls of the root hairs by osmosis and passes into the interior of hairs, thence into the root xylem and through this to stem xylem, thence through stem xylem into the leaves.

**Histology of Stipe (Petiole).**—This, in transverse section, passing from periphery toward the center, presents the following structural characteristics: (see Fig. 15).

1. **Epidermis**, a single layer of epidermal cells with dark brown outer walls.
2. **Outer cortex** (hypodermis), a wide band of small cells with lignified walls.
3. **Inner cortex**, similar to inner cortex of stem but devoid of leaf-trace bundle.
4. **Fundamental parenchyma**, similar to same region of stem, in which are embedded a number of *concentric fibro-vascular bundles* arranged in an interrupted circle. Each of these shows a central

xylem mass surrounded by an outer phloem mass. Each bundle is enveloped by a *pericambium* and an *endodermis* or bundle sheath.

**Histology of Lamina.**—In transverse and surface sections the *lamina* or blade shows the following structural details:

1. **Upper epidermis**, of wavy-walled, slightly chlorophylloid, flat upper epidermal cells, devoid of stomata, but with rather thick cuticle.

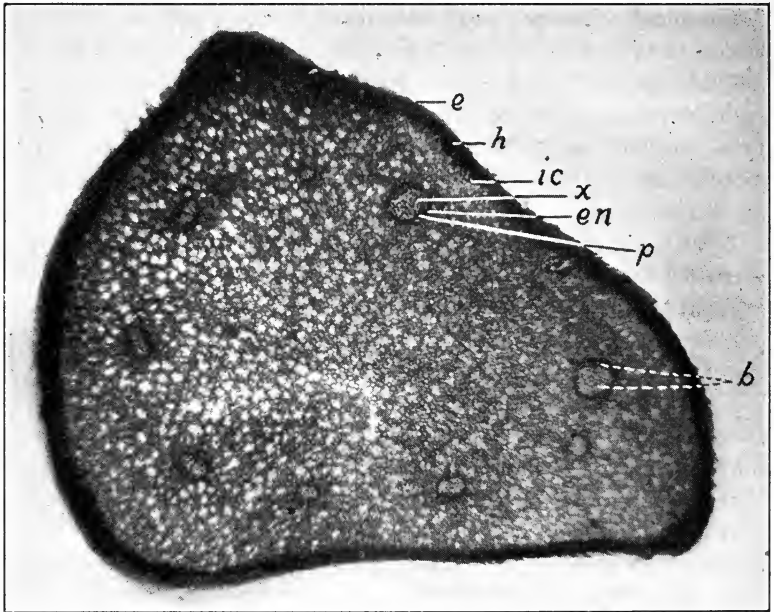

FIG. 15.—Transverse section of stipe of *Dryopteris Filix-mas* showing epidermis (*e*); hypodermis (*h*); inner cortex (*ic*); concentric fibrovascular bundles, one of which is shown at (*b*); endodermis (*en*); pericambium (*p*); xylem (*x*); and phloem (*p*). (Photomicrograph.)  $\times 50.4$ .

2. **Mesophyll**, of irregular shaped chlorophylloid cells, containing abundant chloroplasts. Intercellular-air-spaces are found between various cells which are larger in the lower than in the upper region. Internal glandular-hairs are frequently to be discerned in many of these spaces.

3. **Concentric vascular bundles** or laminar veins, that distribute sap to, and carry sap from the mesophyll. These are seen to be

embedded in the mesophyll. The xylem portion of each bundle is nearest to the upper surface of the leaf and so the bundles approach the collateral type.

4. **Endodermis**, a continuous layer of mesophyll cells which surrounds each bundle and binds it in place.

5. **Lower epidermis** of wavy-walled, flattened, chlorophylloid cells with thin cuticle and many *stomata* (breathing pores). Each **stoma** is surrounded by a pair of crescent-shaped *guard cells* which regulate its opening and closing. The upper and lower epidermis are continuous around the laminar margin.

**Comparative Physiology of Root, Stem and Leaf (Frond).**—The primary function of the roots of the Male Fern is that of absorption of water with mineral salts in solution. The secondary function is that of support for the stem, the tertiary, that of storing food-stuffs to tide the plant over the season when vegetative activities are lessened. Water is the most essential of all materials absorbed by vegetable organisms. It is found in the soil surrounding the soil particles with certain mineral salts dissolved in it. The delicate root-hairs with thin cellulose walls, protoplasmic lining and sap denser than the soil water, are firmly adherent to these particles. The soil water diffuses through these walls by osmosis and comes into relation with the *ectoplasm*, a delicate protoplasmic membrane, which has the power of selecting what it wants and rejecting what it does not need. In this way only such solutes as are of value to the plant are admitted. The water with mineral salts in solution, once within the root-hair protoplast, is called "crude sap." This passes through the hair into the cortical parenchyma cells which are in contact with the spiral ducts and scalariform tracheids. It passes from one cortex cell to another by osmosis and, under considerable root pressure, is forced into the spiral and scalariform tubes of the xylem. Therein it is conveyed upward by root pressure through the tracheids of the stem bundles into those of the leaves and finally osmoses into the leaf parenchyma cells (mesophyll).

Carbon dioxide, ( $\text{CO}_2$ ), from the air, enters the leaf through the stomata. From the stomata it moves through the intercellular-air-spaces to the mesophyll cells which line these, whence it is absorbed. Within the mesophyll cells are found small chloroplasts composed

of protoplasm and chlorophyll. The kinetic energy of the sun's rays is absorbed by the chlorophyll which is thus energized to break up the  $\text{CO}_2$  and  $\text{H}_2\text{O}$  into their component elements C, H and O, and rearrange them in such a way as to ultimately form sugar or starch. This process is called *photosynthesis*. According to von Baeyer,  $\text{CO}_2$  is split into C and  $\text{O}_2$ , the C being retained, the  $\text{O}_2$  given off. The nascent C is linked with  $\text{H}_2\text{O}$  to form  $\text{CH}_2\text{O}$  (formic-aldehyde); six molecules of this are then united to form grape sugar ( $\text{C}_6\text{H}_{12}\text{O}_6$ ). The formation of starch may be expressed by the following equation:  $6\text{CO}_2 + 5\text{H}_2\text{O} = \text{C}_6\text{H}_{10}\text{O}_5 + 6\text{O}_2$ . A portion of the grape sugar is removed from solution by the chloroplast and converted into starch which is stored up within it; another portion is used to nourish the protoplasm of the cell. But the greater portion of sugar manufactured descends in solution through the phloem cells of the bundles of the veins, mid-rib and stipe to the stem or roots, where it is removed from solution by the action of the leucoplasts which convert it into reserve starch. Sugar and starch, however, are not the only food materials manufactured in the leaf. Proteins are likewise formed. These are composed of carbon, hydrogen, oxygen, nitrogen, sulphur and sometimes phosphorus. They are formed from grape sugar with the addition of nitrogen and the other elements by the living protoplasm. The source of nitrogen, sulphur and phosphorus is the mineral salts which are found in the crude sap. These proteins descend through the sieve tubes of the veins, *midrib* and *petiole* to the stem and roots, nourishing all of these parts with protein material.

**Gross Structure and Histology of the Sori and Sporangia.**—The *sporangia* or spore cases are found clustered together in circular groups on the under surface of the *pinnules* nearer the mid-vein than the margin. Each group of sporangia is covered with a membranous expansion of the epidermis called the *indusium*. The whole is called a *sorus* (Fig. 12) (pl. sori) and contains many sporangia. Each *sporangium* is composed of: (a) the *stalk* of considerable length and usually comprising three rows of cells, outgrowths of the epidermis of the *pinnule*; and (b) the *head*, sub-globular and hollow, consisting for the most part of a covering of thin walled, flattened cells, within

which will be noted a marginal ring of cells, with walls having U-shaped thickenings, and called the *annulus*.

Within the sporangium are found the *spores*. Each spore is a single cell composed of an outer brown wall with band-like markings called an *exosporium*, an inner thinner wall or *endosporium*, and within this a mass of protoplasm containing a nucleus.

**Rupture of Sporangium and Spore Dissemination.**—As was previously indicated, each sporangial head has a row of cells with U-shaped thickenings around the margin called an annulus. As the sporangium matures the water escapes from the cells, pulling them together and holding the annulus like a bent spring. The thinner

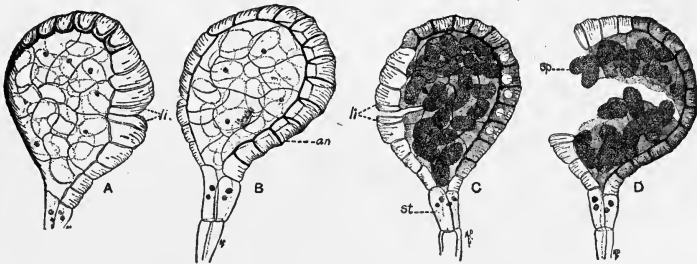

FIG. 16.—Sporangia of an undetermined species of fern; *li*, lip-cells; *an*, annulus; *st*, stalk; *sp*, mature spores. Each of the four nuclei in the upper cells of the stalk is in the terminal cell of one of the four rows of cells that compose the stalk. (Gäger.)

walled cells at the side of the spore case opposite the annulus, unable to stand the strain, are consequently torn; the annulus then straightens and a wide rent is made in the sporangium. The annulus then recoils and hurls the spores out of the sporangium. This closes the *sporophyte* generation.

**History of the Gametophyte or Sexual Generation.**—The fern spore, falling upon a moist surface, germinates, producing a delicate green septate filament called a *protonema*. One end of this structure shows larger cells, which, by the formation of oblique walls, cut out an apical cell of somewhat triangular shape. This is the growing point of what eventually becomes a mature, green, heart-shaped body called the "*prothallium*" or "*prothallus*." The prothallium, about the size of an infant's finger nail, develops on its under surface

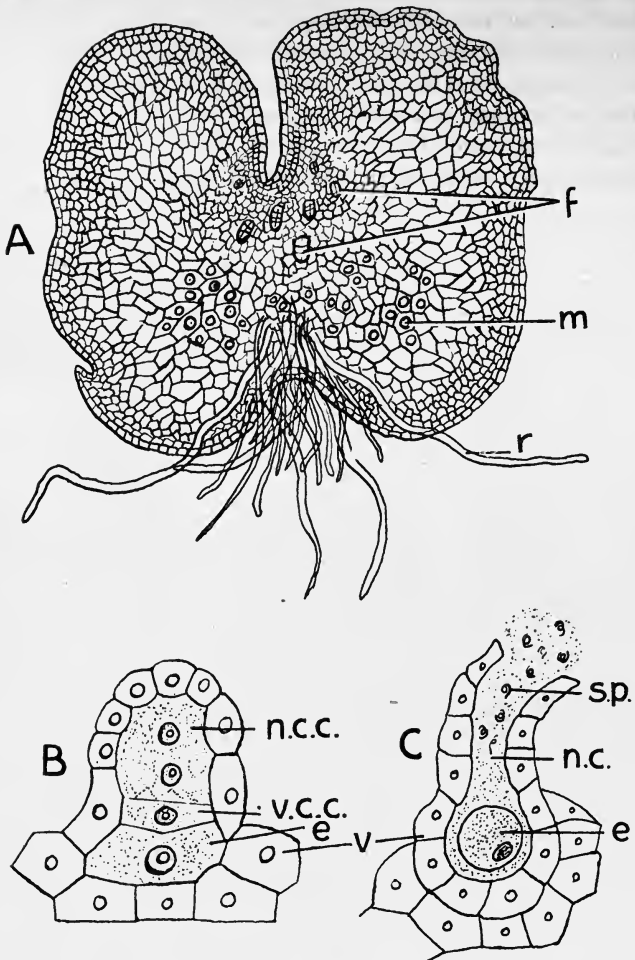

FIG. 17.—A, under surface of a fern prothallium showing archegonia (*f*) antheridia (*m*) and rhizoids (*r*); B, immature archegonium showing binucleate neck canal cell (*n.c.c.*), ventral canal cell (*v.c.c.*), and egg (*e*); C, mature archegonium showing sperms (*sp.*) moving through neck canal (*n.c.*) toward ovum (*e*); and venter (*v*). All highly magnified.



*antheridia*, or male sexual organs, *archegonia*, or female sexual organs, and *rhizoids* or hair-like absorptive structures. The antheridia appear three to five weeks after spore germination. They are hemispherical in shape and are situated among the rhizoids toward the posterior end. Each antheridium consists of a three-celled wall which completely surrounds the *spermatocytes* or mother-cells of the spermatozoids. Within each *spermatocyte* the protoplasm arranges itself in a spiral fashion forming a *spermatozoid*, a spiral, many ciliated, male sexual cell. From two to four weeks after the maturation of the antheridia, the *archegonia* make their appearance toward

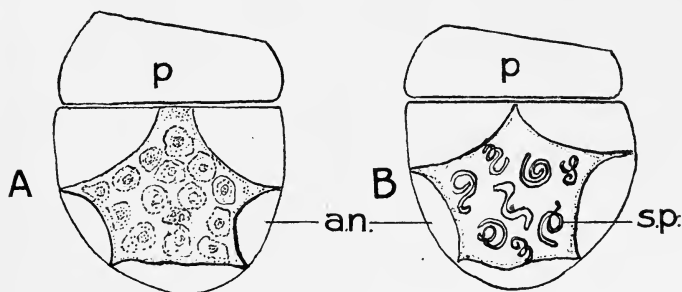

FIG. 18.—A, median longitudinal section through immature antheridium, and cell of prothallium showing prothallial cell (*p*), and antheridial wall surrounding a number of spermatocytes; B, similar section through mature antheridium and cell of prothallium showing fully developed spermatozoids (*sp.*) enclosed by wall of antheridium. Both highly magnified.

the indented apex of the lower prothallial surface as outgrowths of the *prothallial cushion*. Since they appear later than the antheridia they are not likely to be fertilized by spermatozoids from the antheridia of the same prothallium. Each *archegonium* is composed of a *venter*, *neck*, *neck canal-cells*, *ventral canal-cell*, and *ovum* or egg-cell. The neck is composed of cells arranged in four rows, forming a cylinder, one layer of cells thick. This protrudes from the surface of the prothallium and encloses the neck canal-cells and ventral canal-cell. The ovum is embedded in the prothallial cushion just beneath the ventral canal-cell. Upon the maturation of the archegonium, the canal cells are transformed into a mucilaginous substance which fills a canal extending from the outside opening (mouth) to the ovum.

During wet weather the mature antheridial wall bursts open and the many ciliated *spermatozoids* escape into the water. These moving in the water are drawn by the chemotactic malic acid to the mouths of the archegonia of another prothallus, and, passing down the canal of each of these, gather around the ovum. One, probably the best adapted, fuses with the ovum and fertilizes it forming an *oöspore* or fertilized egg.

**Origin of New Sporophyte or Diploid Plant from Fertilized Egg.**—

The fertilized egg now rapidly divides and redivides to form *octant* cells. The octant cells further divide to produce anteriorly a *stem rudiment* (one cell), *first leaf* (two cells), *second leaf* (one cell) and, posteriorly, *root rudiment* (one cell), *foot rudiment* (two cells) and *hair rudiments* (one cell).

**Growth of Seedling into Mature Sporophyte.**—The foot rudiment develops into the foot which obtains nourishment from the prothallium, upon which the young sporophyte is for a time parasitic. The root rudiment becomes the first root which grows downward into the soil. The stem and leaves turn upward. In a few weeks the prothallus decays and the sporophyte is established as an independent plant. More roots and leaves (fronds) are developed and ere long continued growth results in the formation of a mature sporophyte which presents for examination: (1) a *subterranean stem* bearing several *roots*; and (2) *ærial fronds*, each of which consists of a *stipe* or *petiole* and a *lamina* or *blade*, the latter divisible into *pinnæ* or *lobes* and *pinnules*, upon which last *sori* are developed.

**Alternation of Generations.**—It will be observed that in the life cycle of the Male Fern there occur two distinct generations, one, a sporophyte or asexual generation which begins with the *oöspore* and ends with the dispersion of asexual spores; a second, the gametophyte or sexual generation, beginning with the protonemal outgrowth of the spore and ending with the fertilization of the egg to form an *oöspore*. The sporophyte gives rise to the gametophyte which in turn gives origin to the sporophyte.

### CHAPTER III

#### LIFE HISTORY OF A GYMNOSPERM (*PINUS STROBUS*)

The White Pine frequently called the Weymouth Pine (*Pinus Strobus*), one of the principal timber trees of the Northern States

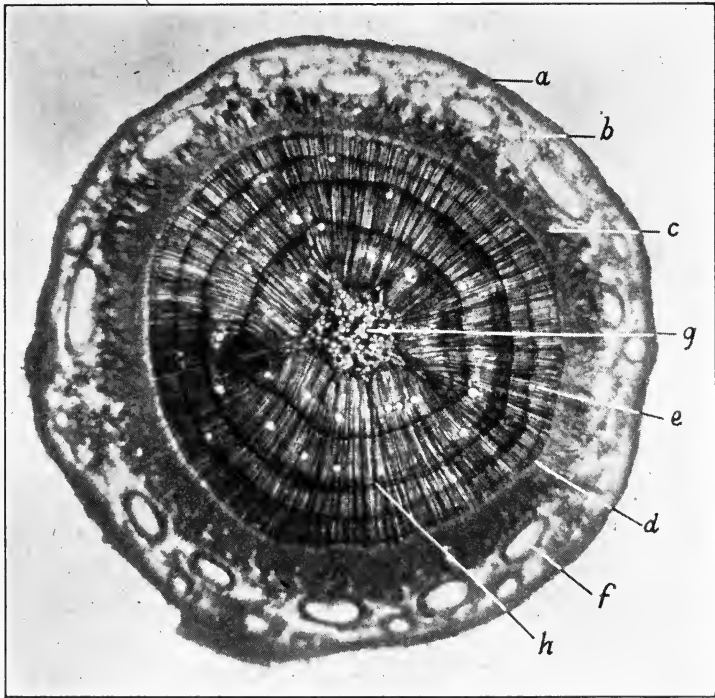

FIG. 19.—Transverse section of white pine stem of four years' growth, showing cork (*a*), cortex (*b*), phloem (*c*), cambium (*d*), xylem (*e*), secretion reservoir (*f*), pith (*g*) and medullary ray (*h*). (Photomicrograph.)  $\times 340$ .

and Canada, is also of value in pharmacy and medicine. The inner bark of its trunk and branches is used because of its valuable expectorant properties and is official in the N. F. IV.

DESCRIPTION OF THE WHITE PINE TREE (MATURE  
SPOROPHYTE)

From an underground spreading root system there arises an erect aerial *trunk* or stem that extends from the ground to the apex of the tree, ending in a terminal bud. The trunk rarely exceeds 3 feet in diameter and 125 feet in height and is averagely  $1\frac{1}{2}$  to 3 feet in

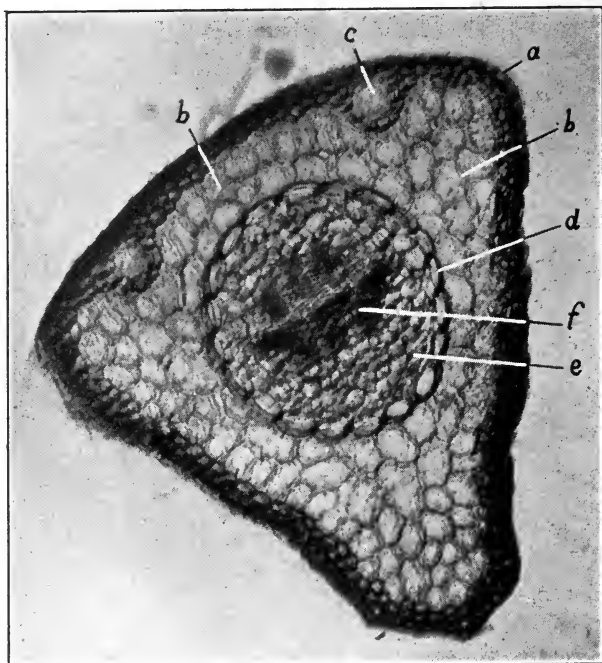

FIG. 20.—Transverse section of white pine needle (leaf) showing epidermis (a), infolded parenchyma cells of mesophyll (b, b'), oil reservoir (c), endodermis (d), clear cellular area (e) surrounding fibrovascular tissue in center (f).  $\times 400$ .

diameter and 50 to 90 feet high. At a varying distance above the soil, depending upon enviroanal conditions as well as the age of plant, whorls of lateral branches (three to seven in a whorl) are seen emanating from the trunk in horizontal fashion at various levels up to near the apex. These become, under conditions prevalent when the tree is grown in the open, gradually shorter until the summit is

reached, giving to the *crown* or upper part of the tree the appearance of a pyramid. These branches give rise to other branches which agree with the lateral branches in bearing, commonly, only scale like leaves as well as in ending in terminal buds. Another kind of branch, however, is found which is always shorter than the scaly branches. This type of branch is called a "*spur shoot*" and arises

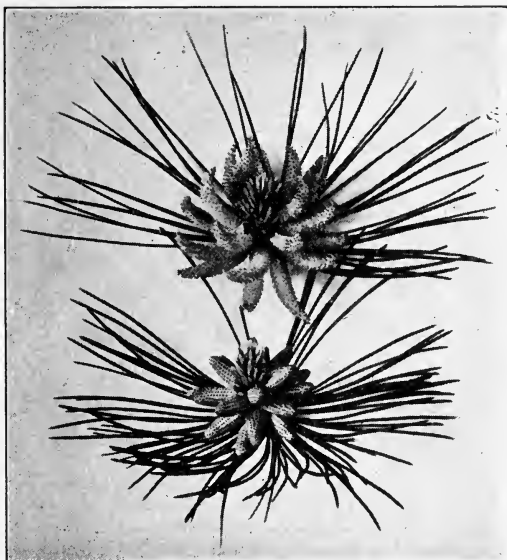

FIG. 21.—Staminate cones of the Austrian pine (*Pinus austriaca*). Below, before shedding pollen; above, after shedding. (Gager.)

from the former branches. The spur shoots bear the *needles* or *foliage leaves* which are light-green, when young, and bluish-green, soft, flexible,  $2\frac{1}{2}$  to 5 inches long, when mature. The "needles" occur in tufts (*fascicles*) of five, are triangular in cross-section, have finely *serrate* (*saw-toothed*) edges and are surrounded at the base by a deciduous sheath. These foliage leaves persist until the end of their second year, when they are shed with the spur shoot which bears them.

The white pine, like most of its allies among the Coniferae, bears cones. These structures are of two kinds, viz.: staminate and carpellate. Both kinds are produced on the same tree.

**Staminate Cones.**—The yellow, ovate, staminate cones appear about May and are clustered at the base of the new growth of the current season. Each consists of a main axis (modified branch) which bears spirals of scales (*microsporophylls* or *stamens*). On the

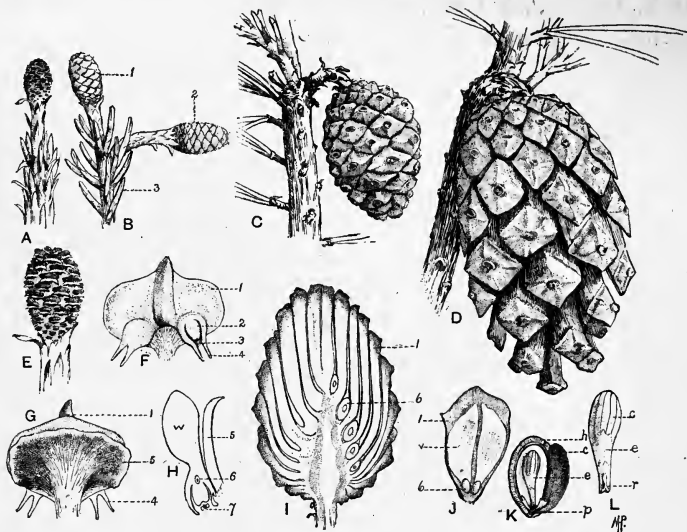

FIG. 22.—Scotch pine (*Pinus sylvestris*). A-D, stages in the development of the carpellate cone, and its carpotropic movements. E, very young carpellate cone much enlarged; F, ventral, G, dorsal views of a scale from E; 1, ovuliferous scale; 2, ovule (in longitudinal section); 3, pollen chamber and micropyle leading to the apex of the nucellus (megasporeangium); 4, integument of the ovule; G, 1, tip of ovuliferous scale; 5, bract; 4, integument; H, longitudinal section at right angles to the surface of the ovuliferous scale (diagrammatic); 6, megaspore; 7, pollen chamber; I, longitudinal section of a mature cone; 6, ovule; J, scale from a mature cone; 6, seed; w, wing of seed; K, dissection of mature seed; h, hard seed coat; c, dry membraneous remains of the nucellus, here folded back to show the endosperm and embryo; e, embryo; p, remains of nucellus; L, embryo; c, cotyledons; e, hypocotyl; r, root-end. (Gager.)

under surface of each scale are the spore-cases (*microsporangia*), which develop the *microspores* (*pollen grains*). Each pollen grain when mature consists of a central fertile cell and a pair of air-sacs or wings, one on either side of the fertile cell. The purpose of the latter is to give greater buoyancy in the air to the microspore.

**Carpellate Cones.**—The young carpellate cones appear in May or early June as pinkish-purple structures arranged in solitary fashion

or in small groups, lateral along the new growth. Each terminates a lateral axillary branch. A carpellate cone is composed of a main axis which bears spirals of scales, by some termed *megasporophylls* (*carpels*). Each scale is composed of an ovuliferous scale bearing two *ovules* or *megasori* and a bract. Each megasorus contains a



FIG. 23.—Mature carpellate cones of white pine showing separated scales.

*nucellus* or *megasporangium* which is surrounded by an integument, except at the apex where an opening, the micropyle is evident. The micropyle is the gateway to the *pollen chamber* which lies below it. Within the nucellus occurs a *megaspore* or *embryo sac*.

#### DESCRIPTION OF THE GAMETOPHYTE GENERATION

The Gametophyte generation of the White Pine begins with the development of the male and female gametophytes and terminates with the fertilization of the egg.

**The Male Gametophyte.**—The male gametophyte commences to form in the mature pollen grain before the pollen is shed. A series

of three nuclear divisions takes place which cut off two small prothallial cells (traces of one of which may be seen pushed up against the wall of the fertile cell of the pollen grain), a tube nucleus and a generative cell. At this stage the pollen is shed and some of it is carried by air currents to the carpellate cones where it sifts in between the ovule-bearing scales and accumulates at the scale bases. A number of the pollen grains are drawn close to the nucellus of the ovule by the drying up of the viscid fluid which fills the *pollen chamber*. In this fluid they germinate forming pollen tubes. The

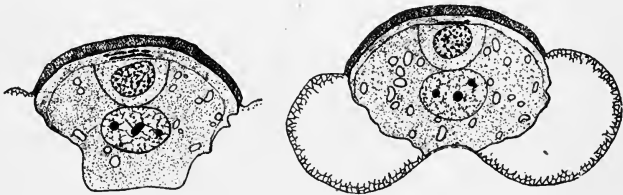

FIG. 24.—The white pine (*Pinus Strobilus*). Sections through mature pollen grains; at the left the remnants of two prothallial cells can be seen, while at the right all signs of the first cell have disappeared. Pollen collected June 9, 1898.  $\times$  about 600. (Gager, after Margaret C. Ferguson.)

transfer of pollen grains from the pollen sac to the pollen chamber and consequent germination therein is called *pollination*. The contents of a mature pollen-grain constitutes the male gametophyte.

**The Female Gametophyte.**—If the embryo sac be examined at about the time of pollination, it will be found to consist of a single cell containing a single nucleus surrounded by cytoplasm. Very shortly afterward, however, the nucleus divides repeatedly to form a large number of nuclei which are scattered throughout the cytoplasm. Each nucleus accumulates around itself a portion of the cytoplasm and ultimately cell walls are laid down and the entire embryo sac contains *endosperm* (prothallial) tissue. Toward the micropylar end of the endosperm (*prothallus*) originate several archegonia.

Each archegonium consists of a much-reduced neck of four cells and an egg (*ovum*) which lies embedded in the prothallus which forms a narrow layer of cells around it called the *jacket*. The contents of the mature embryo-sac constitutes the female gametophyte.



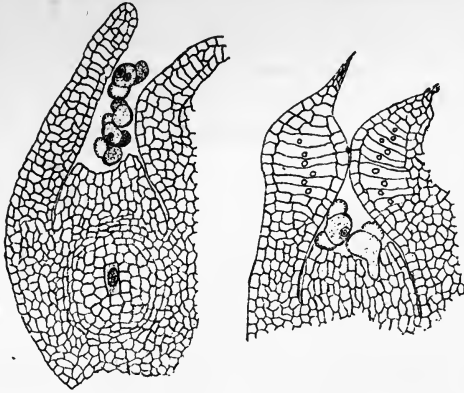

FIG. 25.—White pine (*Pinus Strobus*). At left, megasporangium with megaspore in the center; above, pollen grains in the micropyle and pollen chamber. At right, pollen grains beginning to germinate; the cells of the integument have  $\times$  enlarged and closed the micropyl. (Gager, after Margaret C. Ferguson.)

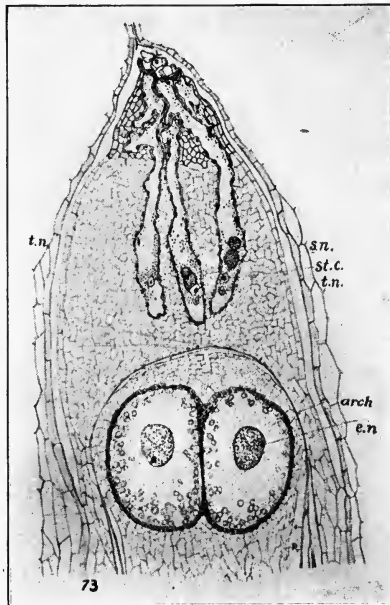

FIG. 26.—White pine (*Pinus Strobus*). Vertical section through the upper part of an ovule, shortly before fertilization. *s.n.*, sperm-nuclei; *st. c.*, stalk-cell; *t.n.*, tube-nucleus; *arch*, archegonium; *e.n.*, egg-nucleus. (Gager, after Margaret C. Ferguson.)

**Fertilization.**—About a year after pollination the pollen tubes, lying within the pollen chamber show signs of renewed activity. The tube nucleus passes to the tip of the tube. The generative-cell divides to form a body and a stalk-cell which pass into the tube. The body-cell later forms two sperm nuclei. While these changes are taking place the tube is penetrating the nucellus and growing toward the embryo sac with its contained female gametophyte. It finally enters it, passing between the neck-cells of the archegonium. The tip of the tube then breaks and the entire tube contents is emptied into the egg. One of the sperm nuclei fuses with the egg nucleus and fertilizes it forming an oöspore.

**Seed Formation and Distribution.**—The oöspore undergoes repeated divisions and forms the *embryo* or young sporophyte plant and a *suspensor* to which it is attached. The embryo is nourished by a portion of the prothallus but the greater part of the prothallus forms the endosperm tissue of the seed surrounding the embryo. The thin nucellus persists as an endosperm covering. The integument becomes modified to form the hard protective seed coat. A portion of the scale of the cone directly above and adjacent to the ovule forms a membranous wing which separates from the scale as part of the seed.

By this time (about two years after pollination) the scales of the cone, now quite woody, separate, the seeds are shaken out, and many are carried for a considerable distance by winds.

**Germination of the Seed.**—Under favorable conditions, the seeds absorb water and germinate in the spring following their dispersal. The hypocotyl of the embryo appears first, arching upward and downward, and, straightening out, draws the green cotyledons with it which spread out toward the light, while it grows into the soil to form the tap root and in time the remainder of the root system. Thus the seedling sporophyte is formed which in time develops into the mature White Pine tree.

## CHAPTER IV

### LIFE HISTORY OF AN ANGIOSPERM (*ERYTHRONIUM AMERICANUM*)

This attractive little plant, commonly called the Dog's Tooth Violet but related to the Lily, is found in the hollows of woods and may be seen in flower during the month of April in the Middle



FIG. 27.—Dog's-tooth violet (*Erythronium americanum*). Stages of development from the seed. 1-5 show the stage of development in each of five successive years. Full explanation in the text. 6, Bulb showing a surface bud (the sprout has been destroyed). (Gager After F. H. Blodgett.)

Atlantic States. It consists of an underground *stem* bearing *scales* (modified leaves) which is termed a *bulb*. From the lower surface of the bulb are given off numerous slender *rootlets* which penetrate the soil and from the upper surface, a pair of oblong lance-shaped

leaves of pale green color mottled with purple and white, and later, a flower stalk (*scape*), which bears upon its summit a single yellow, nodding flower, which is often marked with purple stripes. The flower consists of a *torus* or *receptacle* which will be observed as the upper swollen end of the flower stalk (*scape*). Inserted upon it, passing from periphery toward the center, will be noted four whorls of floral leaves which, in order, are *calyx*, *corolla*, *andræcium* and *gynæcium*. The calyx is composed of three lance-shaped and recurved yellow parts called *sepals*; the corolla of three similarly looking parts called *petals* which alternate in position with the sepals. Both of these whorls are collectively called the *perianth* or floral envelope. The andræcium or male system of organs is composed of two whorls or circles of structures called *microsporophylls* or *stamens*. There are three *stamens* in each whorl. The outer whorl of stamens will be found opposite the sepals while the inner will be observed opposite the petals. Each stamen (microsporophyll) consists of an awl-shaped stalk or *filament* bearing upon its summit an oblong-linear body called an *anther*. The anther consists of two lobes called *microsori*. Each lobe or microsorus contains two anther sacs or *microsporangia* in which when mature are to be found *microspores* or pollen grains. In the center of the flower will be noted the gynæcium or female system of organs. This, upon dissection, will be found to consist of three fused carpellary leaves termed *megasporophylls* (carpels) forming a somewhat flask-shaped structure called a *pistil*: The swollen basal portion of the pistil is called the *ovary*; the stalk which arises from it is called the style and the knob-like viscid summit of the style is termed the *stigma*.

Microscopical examination of sections of the ovary will reveal it to be composed of three chambers called *locules*, within each of which are to be noted several inverted *ovules*. Each of these ovules is developed upon a nourishing tissue termed "*placenta*" which connects the ovules to the inner angle of the wall of the locule. The ovule is composed of a central prominent *megasporangium* or *nucellus* which is almost completely invested by two upgrown integuments or coverings. The opening between the tips of the inner integument is called the *micropyle* (little gate). This is the gateway for the entrance of the pollen tube on its way to the nucellus. It is also

the exit door for the hypocotyl of the embryo after the fertilized and ripened ovule becomes a seed. Within the nucellus, if the sections examined have been properly fixed, will be found a *megaspore* or *embryo sac*.

**Development of the Female Gametophyte Through the Maturation of the Embryo Sac.**—In its immature condition the *embryo sac* (*megaspore*) contains a mass of protoplasm surrounding a nucleus. This nucleus undergoes three divisions forming as a result eight nuclei which ultimately arrange themselves within the protoplasm of the embryo sac as follows: three of them occupy a position at the apex, the lower nucleus of the group being that of the egg or *ovum*, the other two nuclei being the *synergids* or assisting nuclei; at the opposite end of the sac three nuclei known as *antipodals* take their position; the two remaining nuclei called *polar nuclei* take up a position near the center of the embryo sac. In this condition the contents of the embryo sac constitutes the *female gametophyte*. See Fig. 28 (1-8).

#### MATURATION OF THE POLLEN GRAIN AND FORMATION OF THE MALE GAMETOPHYTE

The pollen grains (microspores), within the anther sacs, all arise from a number of *tetrads* (groups of four) which are formed by the division and redivision of *pollen mother-cells* preceding them. Each pollen grain, after the tetrads have separated into their components, consists of an outer firm wall or *exosporium*, an inner wall or *endosporium*, within which will be found the region called the *fovilla*, which is nothing other than a mass of protoplasm containing a nucleus. Before the pollen is shed from the anther its protoplasmic contents undergo a series of changes leading up to the development of the male gametophyte. The nucleus and protoplasm enveloping it divides to form two cells, one a generative-cell containing a generative nucleus, the other a tube-cell containing a tube nucleus. The generative nucleus then divides to form two sperm nuclei and the partition wall between the two cells disappears. In this condition the protoplasmic contents of the pollen grain constitute the *male gametophyte*.

## POLLINATION AND FERTILIZATION

The mature pollen grains are discharged from the ripened anther through the splitting open of its wall. They are transferred to the stigma of the pistil of another *Erythronium* flower through the agency of insects. Here they germinate, each putting forth a tube

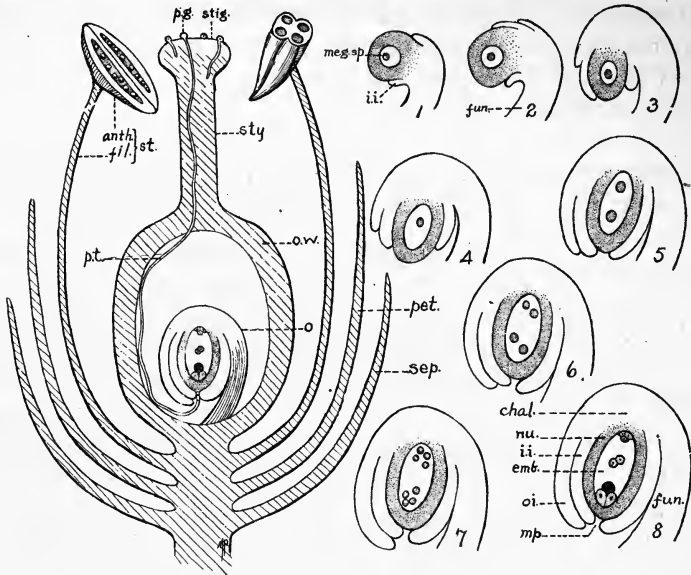

FIG. 28.—At the left, diagram of the anatomy of an angiospermous flower shortly after pollination; *anth.*, anther; *fil.*, filament; *st.*, stamen; *stig.*, stigma; *p.g.*, pollen grains germinating; *sty.*, style; *pt.*, pollen tube; *o.w.*, ovary wall; *o.*, ovule, containing embryo-sac; *pet.*, petal; *sep.*, sepal. 1-8, Stages in the development of the female gametophyte (embryo-sac); *meg.sp.*, megaspore-mothercell; *i.i.*, inner integument; *o.i.*, outer integument; *fun.*, funiculus; *chal.*, chalaza; *nu.*, nucellus (megasporangium); *emb.*, embryo-sac. All diagrammatic. (*Gager.*)

(pollen tube). The pollen tubes, carrying within it two sperm nuclei and a tube nucleus embedded in protoplasm, penetrate through the style canal until they reach the micropyles of various ovules. Each enters and passes through a micropyle, then piercing the nucellus, grows toward the embryo sac. The tip of the tube fuses with the end of the embryo sac and the two sperm nuclei are discharged into the sac. One of these sperm nuclei passes between

the synergids and fuses with the nucleus of the egg to form an *oöspore*. By this time the tube nucleus has disintegrated. The *oöspore* by repeated divisions develops into as many as four *embryos* or young sporophyte plants. Only one of these, however persists. The polar nuclei fuse to form the *endosperm nucleus* which soon undergoes rapid division into a large number of nuclei scattered about through the protoplasm of the embryo sac. Later cell walls are laid down and *endosperm* is formed. The endosperm cells soon become filled with abundant starch which is later to be utilized by the embryo during germination.

#### RIPENING OF THE OVULE TO FORM THE SEED AND OF THE OVARY TO FORM THE FRUIT

When the embryo and endosperm are being formed, the ovule enlarges and its integuments become modified to form a hard horny seed coat which encloses the endosperm surrounding the embryo. The ovary, containing the ovules, has by this time ripened to form a three-valved loculicidal capsule enclosing the seeds.

#### GERMINATION OF THE SEED AND DEVELOPMENT OF THE MATURE SPOROPHYTE

The seeds are fully developed by June or July when the capsule or fruit splits open to discharge them. They fall to the ground and lie dormant until the following spring when they germinate or commence to grow. Each seed absorbs water from the ground which stimulates the ferment amylase, contained in the endosperm cells, to break up the insoluble starch into soluble sugar which passes into solution and diffuses into the cells of the embryo, where the protoplasm changes it into additional protoplasm and so the embryo increases in size, therefore, *grows*. The pressure of the swollen endosperm and growing embryo becomes so great that the seed coat bursts; the hypocotyl emerges first, dragging the cylindrical cotyledon out of the seed coat and epicotyl with it. The hypocotyl elongates and extends itself into the soil where it develops a root near its tip. The tip enlarges through the storage of starch, manufactured by the green cotyledon and becomes a bulb. The bulb soon

develops within it a plumule, the cotyledon withers, and the young plant (seedling) passes the following winter in this condition.

During the next spring the plumule develops into a foliage leaf and the bulb gives rise from its base to several slender elongated *runners*, which, at their tips develop *runner bulbs*. These runner bulbs, the third year, give origin to another set of runners similar to those formed during the second year which also develop runner bulbs at their tips. A foliage leaf is also formed by each. The following spring (spring of fifth year) one of these bulbs develops into a mature sporophyte plant, bearing a single flower at the summit of its elongated scape. See Fig. 27.

#### RESEMBLANCES BETWEEN GYMNOSPERMS AND ANGIOSPERMS

1. In both are developed those structures in which there is no homologue, *e.g.*, flowers.
2. In both the flowers develop at least two sets of leaves (either on one or two plants of the same species) called sporophylla or sporophyll leaves; the stamens and carpels. The stamens or staminal leaves are also termed microsporophylls. The carpels or carpellate leaves are also known as megasporophylls.
3. Both groups produce microspores or pollen grains and megaspores or embryo sacs.
4. In both are developed on the evident generation, the plant or sporophyte and the gametophyte, the latter concealed within the megaspore of the sporophyte.
5. Both develop seeds with one or two seed coats.
6. In both groups there is developed from the fertilized egg an embryo which lies within the cavity of the megaspore.
7. In both there exists a root and a stem pericambium.
8. Both produce collateral vascular bundles. Very rarely do we meet with concentric bundles in the stem or leaf of Angiosperms.

#### FUNDAMENTAL DIFFERENCES BETWEEN GYMNOSPERMS AND ANGIOSPERMS

1. The flowers of Gymnosperms are often monœcious or diœcious but very rarely hermaphrodite, as in *Welwitschia*, whereas those of Angiosperms are usually hermaphrodite, rather rarely monœcious, still more rarely diœcious.



2. In the Gymnosperms the sporophylls are usually inserted either spirally or in whorls around a distinctly elongated axis, whereas in Angiosperms the sporophylls are condensed to short whorls or spirals set around a shortened axis, the floral axis or receptacle, torus or thalamus, or, as in the more modified Angiosperms, the floral axis may even become hollow.

3. In Gymnosperms the microsporophylls or stamens are usually sessile, whereas in Angiosperms the microsporophylls are nearly always stalked. Rarely do we find sessile anthers among Angiosperms, an instance of this being seen in Mistletoe (*Viscum*) where the anthers are set on the staminal leaf.

4. In Gymnosperms there is a traceable prothallus or gametophyte plant that later becomes the so-called "endosperm" of the gymnosperm, whereas in Angiosperms no recognizable prothallus has been proven to exist.

5. The stored food tissue in Gymnosperm seeds is prothallial tissue loaded with starch, etc., whereas in Angiosperm seeds the stored food tissue (endosperm) is a special formation after fertilization.

6. Gymnosperms bear naked ovules and seeds while Angiosperms bear covered ones.

7. In Gymnosperms there are distinct recognizable archegonia formed on or imbedded in the prothallus, whereas in Angiosperms there are no distinct archegonia, only an isolated egg or eggs.

8. In Gymnosperms there are not infrequently found several embryos from one fertilized egg. This condition is called *polyembryony*. Polyembryony is unknown in Angiosperms, only a *false polyembryony* being noticed.

9. In Gymnosperms the secondary xylem (wood) tissue of roots, stems and leaves consists either of punctated or scalariform cells, whereas in Angiosperms the secondary wood tissue may be varied in structural aspect.

## CHAPTER V

### VEGETABLE CYTOLOGY

*Vegetable Cytology* treats of plant cells and their contents.

#### THE PLANT CELL AS THE FUNDAMENTAL UNIT

Schleiden, in 1838, showed the cell to be the unit of plant structure. The bodies of all plants are composed of one or more of these fundamental units. Each cell consists of a mass of protoplasm which may or may not have a cell wall surrounding it. While most plant cells contain a nucleus and some contain a number of nuclei, the cells of the blue-green algæ and most of the bacteria have been found to lack definitely organized structures of this kind but rather contain chromatin within their protoplasm in a more or less diffuse or loosely aggregated condition.

#### A TYPICAL PLANT CELL

If we peel off a portion of the thin colorless skin or *epidermis* from the inner concave surface of an onion bulb scale, mount in water and examine under the microscope, we find it to be composed of a large number of similar cells which are separated from one another by means of lines, the bounding cell walls. Under high power each of these cells will exhibit the following characteristics:

An outer wall, highly refractile in nature and composed of *cellulose*; which surrounds the living matter or *protoplasm* (See Fig. 29). This wall is not living itself but is formed by the living matter of the cell. Somewhere within the protoplasm will be noted a denser-looking body. This is the *nucleus*. Within the nucleus will be seen one or more smaller highly refractile and definitely circumscribed *bodies*, the *nucleolus* or *nucleoli*. The protoplasm of the cell outside of the nucleus is called the "*cytoplasm*." It will be seen to be clear and

granular-looking. Within the cytoplasm will be observed a number of clear spaces. These are *vacuoles* and because they are filled with *cell sap* (water with nutrient substances in solution) are called "sap *vacuoles*."

Protoplasm is in intimate relation to water. The reaction of the cytoplasm to a bounding film of water between it and the cell wall forms the *outer plasma membrane* or *ectoplasm*, a clear homogeneous outer band of cytoplasm; the reaction of cytoplasm to the water

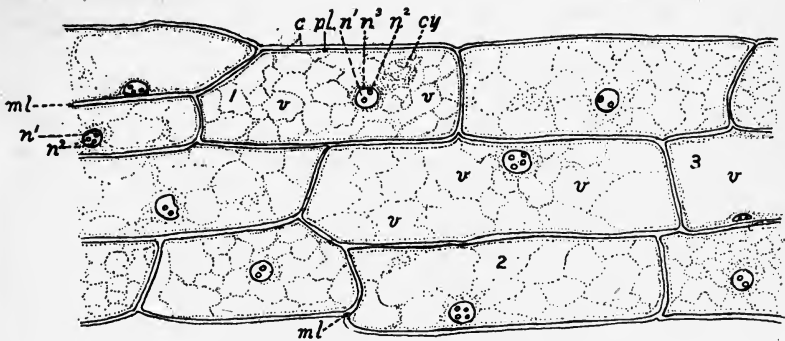

FIG. 29.—Portion of inner epidermis of Onion bulb scale showing cells at various stages of maturity. Young cell (1); old cell (3); cell intermediate in age between 1 and 3 (2); cell wall (*c*); outer plasma membrane (*pl*); middle lamella (*ml*); nucleus ( $n^1$ ); nucleolus ( $n^2$ ); nuclear membrane ( $n^3$ ); cytoplasm (*cy*); vacuole (*v*). Note that the young cell (1) shows numerous small vacuoles and spheroidal nucleus near center of cytoplasm. In 2 (cell of intermediate age) the cell has enlarged, larger vacuoles have formed thru the bursting of films of cytoplasm separating smaller ones, and the nucleus has moved toward the cell wall. In 3, the films have all burst, the cytoplasm and nucleus have been pushed up against the cell wall, the nucleus is flattened out, and a large vacuole appears in the center of the cell.

within the sap vacuoles forms the *vacuolar membranes*; the reaction of the dense protoplasm of the nucleus to the water in the cytoplasm around it forms the *nuclear membrane*. Upon mounting another portion of epidermis in iodine solution, removing the excess of stain and adding a drop of sulphuric acid and then examining under high power, we note that the cell walls of cellulose are stained a deep blue. A yellow line is evident in the middle of each cell wall and separates each cell from its bounding cells. This line is the *middle lamella* which is composed largely of *calcium pectate*.

## PROTOPLASM AND ITS PROPERTIES

**Protoplasm**, or living matter, is the more or less semi-fluid, viscid, foamy, and granular substance in which life resides. It is the "physical basis of life."

The peculiar properties which distinguish protoplasm from non-living matter are as follows:

1. **Structure**.—Protoplasm invariably exhibits structure. No portion of it, however small, has been found to be homogeneous. Each advance in microscopical technique reveals new complexities. The protoplasm of a single cell, far from being a single unit, must rather be looked upon as a microcosm.

2. **Metabolism**.—Perhaps the most significant peculiarity of living matter is found in its instability and the chemical changes which continually go on within it. It is constantly wasting away, and as constantly being built up. These losses and gains are not upon the exterior surface, but throughout its mass. Its growth and renewal are by *intussusception*, or the taking in of new particles, and storing them between those already present. A bit of protoplasm may retain its identity while all the matter of which it is composed is changed over and over. It is like a whirlpool or wave in a river which remains the same while the water of which it is composed changes continually. Metabolism has been aptly defined by Huxley as the whirlpool character of the organism.

3. **Irritability**.—All living matter responds to stimulation. When matter fails to be irritable or responsive to stimuli, we declare it to be dead. The stimuli that excite reactions in living matter are of two kinds, viz; intrinsic and extrinsic.

Intrinsic stimuli are inherited stimuli. They determine that the plant shall conform to a particular type, carry on certain activities, pass through a definite life cycle, and detach a portion of its own substance for the formation of new individuals of its kind.

Extrinsic stimuli initiate, inhibit, accelerate or modify the effects of intrinsic stimuli. They comprise agents of the external world such as cold, heat, chemicals, food, water, light, oxygen, electricity, gravity etc.

The irritable reactions manifested by protoplasm and living things to the effects of these external agents will now be considered briefly.

*Thermotropism* is the response of living substance to the stimulus of temperature. All living substance is influenced by variations in temperature. Freezing disintegrates it while excessive heat causes its coagulation. Active vital phenomena are therefore only evident within these extremes, the limits differing depending upon the endurance of the organism under examination. The lowest temperature at which the activity of an organism becomes evident is known as the minimum, that at which the activities are at their best, the optimum, and the highest at which they can be continued, the maximum. Some plants are able to endure greater extremes of temperature variation than others because of special adaptations. Thus, certain bacteria produce spores which resist exposure for an hour to the temperature of liquid hydrogen ( $-225^{\circ}\text{C}$ ) or to that of a hot air oven at  $100^{\circ}\text{C}$ . Many higher plants can endure moderately low temperatures by the development of a hairy covering; others which are killed by frost produce seeds which can endure rigid cold, still others adapt themselves to existence through periods of cold by passing through a latent stage in the form of bulbs, like the Squill or the Lily, or rhizomes, as the Blood Root or the Hellebores.

*Chemotropism* is the response of protoplasm to chemical stimulation. Any substances that possess the property of producing a deleterious effect upon protoplasm are termed poisons. Poisons may effect an immediate destructive combination with living substance when they are called *caustics*, or they may have an exciting or depressing effect which may eventually prove destructive without visible structural change, when they are termed *toxins*. Caustics may liquefy the protoplasm, as the alkalis, or coagulate it, as the acids or salts of metals. When well diluted, chemicals may occasion no destructive effects, but may call forth positive or negative responses, known as positive or negative chemotropism.

Thus, Pfeffer, working with the motile sperms of ferns, found that if a capillary tube, containing a solution of malic acid be introduced into water containing them, the sperms moved toward it and entered. It is now generally believed that the motile male sexual cells of all flowerless plants are attracted to the appropriate female sexual cells by means of positive chemotropic influences. Among flowering plants, it has been observed that pollen grains brought by various

agencies from anthers to stigmas of certain plants of different species will not germinate but when they are carried from one plant to another of the same species or variety they readily send their pollen tubes through stigma and style to the ovule below. In the former instance, negative chemotropism is illustrated, while, in the latter, positive chemotropism is shown.

*Sitotropism* is the reaction of living matter to the influence of food. Hertwig found that if a fine capillary tube be filled with a 1 per cent. solution of asparagin or beef extract and held in contact with a drop of water containing certain bacteria, a mass of these soon plugged the mouth of the tube. His experiment shows that these organisms moved from a poorer to a richer nutrient medium in response to a positive sitotropic influence. Oxytropism is the response to the stimulating influence of oxygen. We see evidence of this everywhere in nature. No living thing can continue to exist without this element. A mistaken idea is often prevalent regarding obligate anaerobic bacteria. Like all other bacteria or organisms, these plants require oxygen but can only assimilate it in its combined form. The tetanus bacillus is a good example. Aërobic bacteria, on the other hand, require free (uncombined) oxygen for assimilative purposes. Thus the tetanus organism grows in the depth of culture media, whereas the tubercle bacterium (an aerobe) grows only on the surface.

*Hydrotropism* is the response of protoplasm to the stimulus of water. This reaction is seen in both positive and negative phases in the slime molds. The vegetative stage of these lowly plants is characterized by a naked many nucleated mass of protoplasm, confining itself to the moist crevices of rotten logs etc. until the surface of the substratum becomes wet when and only when it will emerge. As soon, however, as its fruiting stage begins, the whole protoplasmic mass wells up from the substratum, away from moisture. The roots of young seedling plants show positive hydrotropism by growing toward moisture in the soil.

*Heliotropism* is the response of living substance to the stimulus of light. The stems of higher plants tend to grow toward the light and are, therefore, positively heliotropic, whereas the roots grow away from the source of light and so are negatively heliotropic.

*Geotropism* is the response of protoplasm to the stimulus of gravity. Roots of Pteridophytes and seed plants invariably grow downward toward the center of gravity and so are positively geotropic. The



FIG. 30.—Venus fly-traps, *Dionaea muscipula*, growing in field near Wilmington, N. C. (Photograph by Charles Palmer.)

fruiting organs of the fungi and the main stems of higher plants tend to grow perpendicular to the earth's surface and so are negatively geotropic. Branches of stems that assume a relation parallel

to the earth's surface are diageotropic. The Lima Bean, Sarsaparilla, Poison Ivy, and other plants whose stems twine about supports exhibit lateral geotropism in their horizontal curvatures.

*Galvanotropism* is the reaction of protoplasm to electrical stimuli. In this connection it may be said that the degree of response bears a definite relation to the intensity of the stimulus. No visible external electrotopic reactions have been observed in higher plants,

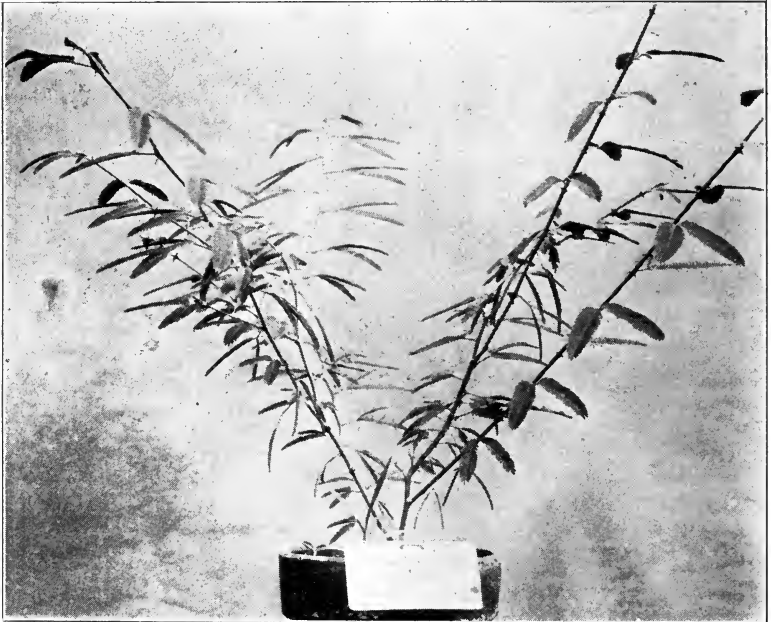

FIG. 31.—*Mimosa Spegazzini*. Note the expanded condition of the leaves before stimulation. (After Steckbeck.)

although when their cells are examined microscopically, the reaction becomes manifest. Kühne has shown that when an electric current is passed through the hairs of the Spiderwort, the cytoplasm becomes gathered into small globular masses.

*Thigmotropism* is the response of living matter to mechanical stimulation. Examples of this form of irritability appear to be far less common among plants than among animals. Certain species



of *Mimosa*, *Oxalis*, *Drosera*, *Desmodium* and *Dionæa muscipula* exhibit this phenomenon to a marked degree. A few instances only will be considered. When the tendrils of climbing plants come into contact with the uneven surface of solid bodies they are induced to coil. When the tentacles on a modified leaf of the Sundew (*Drosera*) are stimulated mechanically by an insect or artificially they are induced to curve over. If a good plant of the Venus Fly-trap (*Dionæa*)

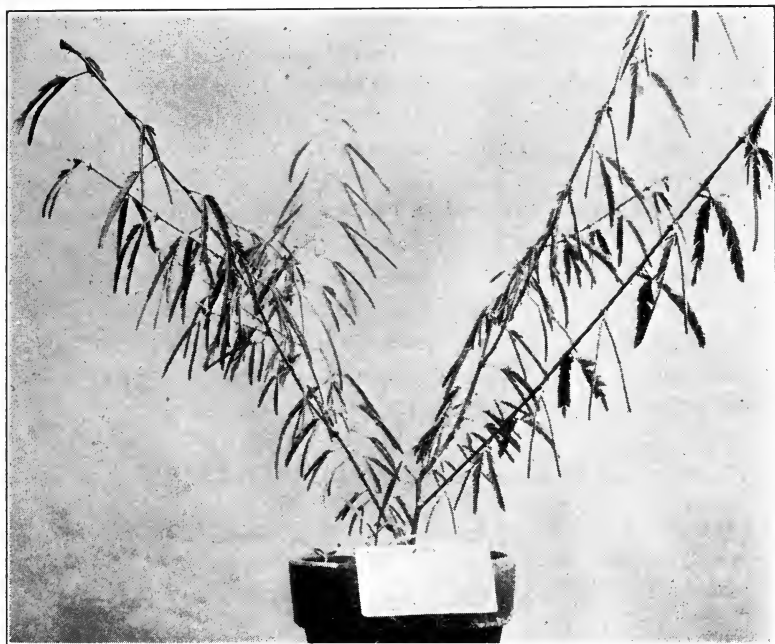

FIG.32.— *Mimosa Spegazzini*. After the application of a stimulus. Compare with Fig. 31. (After Steckbeck.)

is selected, it will be seen to possess leaves, the terminal portions of which are modified as traps for catching insects (Fig. 30). Hairs will be seen projecting from the upper surface of each valve of the hinged blade. If one of these hairs is touched with a pencil no reaction will be evident but if after a lapse of twenty seconds the hair is touched again, the 2 valves close. If the stamens of *Berberis* be touched near the base during their pollen shedding stage they will be observed to curve toward the stigma.

The most highly specialized form of thigmotropism observed in plants appears to be found in *Mimosa Spegazzini*, a member of the Bean family. According to Steckbeck "when a mechanical stimulus, such as a forceps pinch, is applied to one of the terminal secondary leaflets after a latent period of less than  $\frac{1}{4}$  second, the leaflet stimulated rises and its partner almost at the same time. The stimulus is then carried down the midrib, the pairs of secondary leaflets closing in order; in 9 seconds all the secondary leaflets have closed, the midribs converge followed in 3 seconds by a drop of the entire leaf. The stimulus moves up the other leaflet with the result that the secondary leaflets close in order." In 20 seconds after the stimulus has been applied all of the secondary leaflets are closed. The stimulus is propagated through the stem to other leaves."<sup>1</sup> (Figs. 31 and 32.)

4. **Reproduction.**—Protoplasm also shows a very remarkable ability to increase and to give off detached portions which retain the infinitely complex peculiarities and properties of the original. The process, moreover, may be continued indefinitely.

Other physiological characteristics might be added, but the above are mentioned as the most satisfactory criteria by which living may be distinguished from non-living matter.

### PROTOPLASMIC CELL CONTENTS

Protoplasm consists of four well-differentiated portions:

(a) **Cytoplasm**, or the foamy, often granular matrix of protoplasm outside of the nucleus.

(b) **Nucleus** or **Nucleoplasm**, a denser region of protoplasm containing chromatin, a substance staining heavily with certain basic dyes.

(c) **Nucleolus**, a small body of dense protoplasm within the nucleus.

(d) **Plastids**, composed of plastid plasm, small discoid, spheroidal, ellipsoidal or ribbon-shaped bodies scattered about in the cytoplasm.

<sup>1</sup> "The comparative histology and irritability of sensitive plants" by D. W. Steckbeck in Contributions from The Botanical Laboratory of the U. of Pa., vol. IV, No. 2, p. 217, 1919.

Sometimes, as in the cells of lower plants like the *Spirogyra*, plastids are large and are then called **chromatophores**.

According to the position of the cells in which plastids occur and the work they perform, they differ in color, viz:

**Leucoplasts** are colorless plastids found in the underground

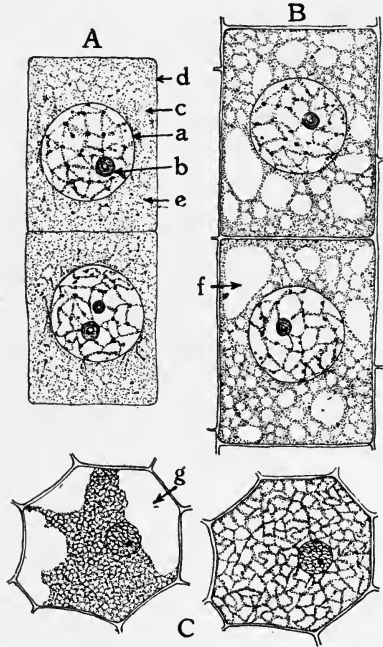

FIG. 33.—A, embryonic cells from onion root tip; *d*, plasmatic membrane; *c*, cytoplasm; *a*, nuclear membrane enclosing the thread-like nuclear reticulum; *b*, nucleolus; *e*, plastids (black dots scattered about). B, older cells farther back from the root tip. The cytoplasm is becoming vacuolate; *f*, vacuole. C, a cell from the epidermis of the mid-rib of *Tradescantia zebrina*, in its natural condition on the right, and plasmolyzed by a salt solution on the left; *g*, space left by the recedence of the cytoplasm from the wall; the plasma membrane can now be seen as a delicate membrane bounding the shrunken protoplast. All highly magnified. (*Stevens*.)

portions of a plant and also in seeds, and other regions given up to the storage of starch. Their function is to build up reserve starch from sugar and other carbohydrates as well as to change the reserve starch back into sugar when it is needed for the growth of the plant.

They are only evident after properly fixing and staining cells containing them.

**Chloroplastids** are plastids found in cells exposed to light and contain the green pigment, chlorophyll.

**Chromoplastids** are plastids found in cells independent of their relation to light or darkness and contain a yellow, orange or red pigment called chromophyll.

### CELL FORMATION AND REPRODUCTION

The cells of plants have all been derived from preëxisting cells. In the bacteria and many other low forms of plant life, the division of the cell always results in reproduction; in higher forms, however, it merely increases the size of the individual and so is a phenomenon of growth.

There are two kinds of cells formed by plants, viz.: *asexual* and *sexual*. Both of these are endowed with the possibilities of reproduction, although the former are frequently limited to the process of growth.

*Reproduction* is the power possessed by an organism of giving rise to new individuals. This may take place through the agency of either asexual or sexual cells and is accordingly asexual or sexual in character. Whenever a union of cells or their protoplasmic contents takes place the process is called "sexual reproduction;" if, however, there is a mere separation of a cell or cells from an individual which later form a new organism, the process is termed "asexual or vegetative reproduction."

There are four modes of asexual reproduction, viz.: *Fission*, *Gemmation*, *Free Cell Formation* and *Rejuvenescence*.

**Fission.**—This is the separation of a cell into two equal halves, each of which may grow to the size of the original parent cell from which it was derived. Fission is seen in the reproduction of bacteria, growth of many algæ and the formation of tissues of higher plants.

**Gemmation or Budding.**—This is the method of reproduction common among yeasts. The cell forms a protuberance called a bud which increases in size until it equals the size of the cell which formed it and then becomes detached, although frequently not until it has developed other buds and these still others.

**Free Cell Formation.**—This is a type of reproduction in which the nucleus and protoplasm become separated into two or more masses each of which forms a cell wall about itself. Seen in formation of ascospores within ascus of Ascomycetes and spores within spore cases of molds.

**Rejuvenescence.**—In this mode of reproduction the protoplasm of the cell becomes rounded out, escapes by rupture of the cell wall, forms cilia and moves about as a *zoöspore*. Later it loses its cilia, develops a cell wall and passes into a resting condition. Under favorable circumstances it grows into a new organism. It is found in *Aedogonium*, *Ectocarpus*, etc.

There are two kinds of sexual reproduction, viz.: *Conjugation* and *Fertilization*. In both of these the sexual cells called *gametes* or their nuclei come together and their protoplasm blends to form a new cell. This is the common method seen in higher plants.

**Conjugation.**—A union of two gametes, alike in character, the product being a *zygote* or *zygospore*. This method of reproduction is seen in the molds, *Spirogyra*, *Zygnema* and Diatoms.

**Fertilization.**—A union of two unlike gametes or their nuclei, the product being an oöspore. One gamete, the male sexual cell, is smaller and active, while the other, the female sexual cell, is larger and passive. This process is seen among the higher and many of the lower plants.

#### INDIRECT NUCLEAR DIVISION (MITOSIS OR KARYOKINESIS)

This is the general method of division seen in the formation of tissues of higher plants.

The process begins in the nucleus and ends with the formation of a cell wall dividing the new-formed cells.

When we examine a cell in its *resting stage* we find the nucleus more or less spherical in shape, surrounded by a *nuclear membrane* and containing a *nuclear network*, *nuclear sap* and one or more *nucleoli*. The nuclear network consists of a colorless network of *linin* adhering to which are numerous minute granules called *chromatin* which take the stain of a basic dye. Surrounding the nucleus is the *cytoplasm*.

As the cell commences to divide, the nucleus elongates and the

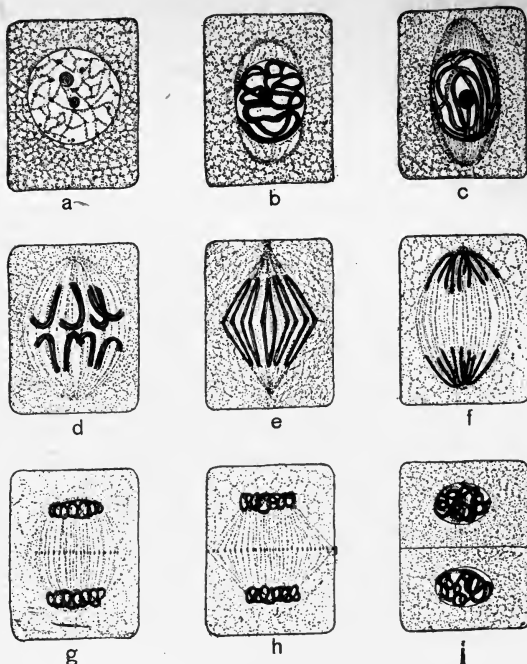

FIG. 34.—Semi-diagrammatic representation of nuclear and cell-division, *a*, resting cell ready to begin division; *b*, the nuclear reticulum is assuming the form of a thickened thread, and the cytoplasm at opposite poles is becoming thread-like to form the spindle fibers; *c*, the nuclear thread has divided longitudinally through the middle, and the spindle fibers have become more definite; *d*, the nuclear membrane and the nucleolus have disappeared, and the nuclear thread has become segmented into chromosomes which are assembling at the equator or the cell. All of the phases of division thus far are called *prophases*. *e*, the metaphase, where the longitudinal halves of the chromosomes are being drawn apart preparatory to their journey toward the opposite poles; *f*, the anaphase, or movement of the chromosomes toward the poles, is about completed, connecting fibers extend from pole to pole; *g*, telophase where the chromosomes have begun to spin out in the form of a nuclear reticulum. The connecting fibers have begun to thicken in the equatorial plane; *h*, the connecting fibers have spread out and come into contact with the wall of the mother cell in the equatorial plane, and the thickening of the fibers throughout this plane has made a complete cell plate within which the dividing wall will be produced; *i*, a nuclear membrane has been formed about each daughter nucleus, and the dividing cell-wall is completed. The two daughter cells are now ready to grow to the size of the parent cell in *a*, when the daughter nuclei will appear as does the nucleus there. All highly magnified. (Stevens.)

linin threads of the nuclear reticulum shorten, drawing the chromatin granules together into a thickened twisted chromatic thread. This thread splits transversely and thus becomes divided into a number of rods termed *chromosomes*. Each of these then splits into two longitudinal halves that may be termed the *daughter-chromosomes*. They lie within the nuclear cavity united by delicate threads. There now begins a phenomenon concerned with the cytoplasm which is primarily a process of spindle formation. The granular cytoplasm accumulates at the poles of the elongated nucleus forming the *cytoplasmic caps*. Presently it begins to show a fibrillar structure, the threads extending outward around the periphery of the nucleus forming an umbrella-like arrangement of fibers from both cytoplasmic caps. With the formation of fibers comes a breaking down of the nuclear membrane and in consequence the fibers enter the nuclear cavity and organize the *spindle*. Some of the fibers become attached to the split chromosomes and push, draw or pull them to the *equatorial plate*, halfway between the poles. Meanwhile the nucleolus disappears. As the chromosomes line up at the *equatorial plate* their daughter halves are drawn apart in V-shaped fashion. The split extends and eventually one daughter-chromosome is drawn to one pole and the remaining half to the other. At the respective poles the daughter chromosomes form a dense compact knot. A cell membrane, composed of material contributed largely through the shrinking of the spindle fibers, is now formed through the middle of the spindle. This soon splits to form a thin vacuole lying between the two membranes (the *plasma membranes*). Presently there appears within the vacuole and between the membranes a carbohydrate substance. On either side of this deposit the plasma membranes form a cellulose membrane. The flattened vacuole extends toward the periphery and ultimately a complete cell wall is formed.

The dense compact knots of chromosomes at the poles of the spindle, that are to form the daughter-nuclei, now begin to expand and clear mesh-like spaces to appear between the expanding threads. As this process advances the chromosome substance becomes distributed throughout the nuclear cavity. It is soon possible to distinguish the chromatin from the linin. Eventually an irregular

network of linin carrying chromatin granules is formed through the area of the nucleus. A nuclear membrane also is formed and the nucleolus reappears. The spindle fibers disappear. The daughter-nuclei increase in size and each *daughter-cell* formed by this process now assumes the resting stage.

### NON-PROTOPLASMIC CELL CONTENTS

1. **Sugars.**—*Sugars* comprise a group of crystalline substances found in the cell sap of many plants either free or in combination with glucosides. They may be divided into two main groups: monosaccharoses and disaccharoses. To the former belong simple sugars containing two to nine atoms of carbon, which are known respectively as bioses, trioses, tetroses, pentoses, hexoses, etc. Of these the hexoses ( $C_6H_{12}O_6$ ) are the most important and of wide distribution. Examples of the hexoses found in drug plants are: (a) dextrose (grape sugar), found in the leaves, stems, fruits, sprouting grains and nectaries of flowers of nearly all plants; (b) fructose (levulose or fruit-sugar), commonly associated with dextrose; (c) d-mannose, found in the saccharine exudation of the Manna Ash (*Fraxinus Ornus*); and (d) sorbinose, found in ripe Mountain Ash berries. Upon evaporating the sap or treating the parts containing these principles with alcohol they can be crystallized out.

Flückiger's Micro-chemic Test for the determination of different kinds of sugars: Dissolve a small portion of copper tartrate in a drop of sodium hydrate on a glass slide; in this place the section and put on the cover slip. If fructose is present cuprous oxide crystals will at once be formed without warming. If grape sugar is also present a gentle warming will produce another crop of reddish-yellow crystals. If dextrin be present continued heating will still further augment the number of crystals. Cane sugar and mannite, on the other hand, will respond negatively to this test. The *zymase* of yeasts is capable of fermenting dextrose, levulose and d-mannose forming carbon dioxide and alcohol. Sorbinose is claimed to be non-fermentable.

The disaccharoses, having the chemical formula of  $C_{12}H_{22}O_{11}$ , include sucrose, maltose, trehalose, melibiose, touranose and agavose. Of these *sucrose* is the most important. It is found in the stems of



sugar cane, sorghum, corn and Mexican grass; in many fleshy roots notably the sugar beet; in the sap of the sugar maple and various palms including *Cocos nucifera*, *Phœnix sylvestris*, *Arenga saccharifera*; in various fruits, as apples, cherries, figs, etc., in the nectaries of certain flowers; in honey; and in a number of seeds. It crystallizes in monoclinic prisms or pyramids. When sections of plant parts containing cane sugar are placed for a few seconds in a saturated solution of copper sulphate, then quickly rinsed in water, transferred to a solution of 1 part of KOH in 1 part of water, and heated to boiling, the cells containing the sugar take on a sky-blue color. *Invertase* of the yeast reduces cane sugar to dextrose and levulose and *zymase* of the same plant ferments these forming carbon dioxide and alcohol.

**Maltose** is found in the germinating grains of barley and other cereals as a product of the action of the ferment diastase on starch. It reduces Fehling's solution, forming cuprous oxide, but one-third less with equal weights.

**Trehalose** or mycose is found in ergot, *Boletus edulis*, the Oriental Trehala and various other fungi.

**Melibiose** is formed with fructose upon hydrolyzing the trisaccharose melitose which occurs in the molasses of sugar manufacture and in Australian manna.

**Touranose** is produced upon hydrolyzing melizitose, a trisaccharose which occurs in Persian manna, and

**Agavose** is found in the cell sap of the American Century Plant, *Agave americana*.

2. **Starch**.—Starch is a carbohydrate having the chemical formula of  $(C_6H_{10}O_5)_n$  which is generally found as the first visible product of photosynthesis in most green plants. It is found in the chloroplasts and chromatophores of green parts in the form of minute granules. This kind of starch is known as **Assimilation Starch**. Assimilation starch is dissolved during darkness within the chloroplasts by the action of ferments and passes into solution as a glucose which is conveyed downward to those parts of the plant requiring food. In its descent some of it is stored up in medullary ray cells, and in various parts of the xylem, phloem, pith and cortex in the form of small grains. Considerable, however, is carried down to

the underground parts, such as rhizomes, tubers, corms, bulbs or roots, where the leucoplasts store it in the form of larger-sized grains called **Reserve Starch**. This type of starch is generally characteristic for the plant in which it is found. It constitutes stored-up food for the plant during that period of the year when the vegetative processes are more or less dormant.

**Structure and Composition of Starch.**—Starch grains vary in shape from spheroidal to oval to chonchoidal to polygonal. They

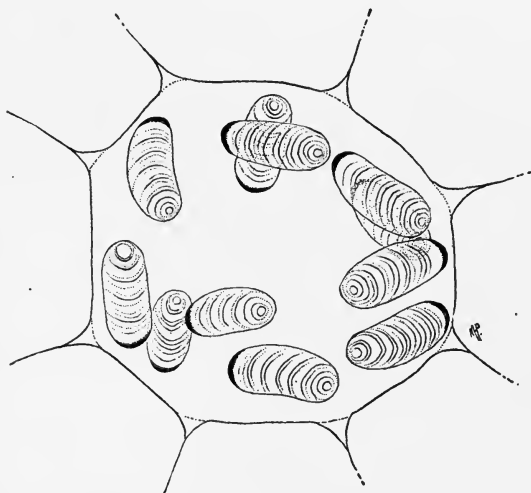

FIG. 35.—Cell of *Pellionia Daveauana*, showing starch-grains. The black, crescent-shaped body on the end of each grain is the *leucoplast*. Greatly enlarged. (Gager.)

are composed of layers of soluble carbohydrate material and probably other substances called "*lamellæ*," separated from each other by a *colloidal substance* resembling a mucilage in its behavior toward aniline dyes. They contain a more or less distinct highly refractile point of origin or growth called the "*hilum*," which also takes the stain of an aniline dye. The layers of carbohydrate material stain variously, blue, indigo, purple, etc., with different strengths of iodine solutions. Each grain is covered with a stainable elastic membrane.

Starch grains may be grouped, according to the condition in which they are found in the cells of storage regions into three kinds, viz.: *simple starch grains*, *compound starch grains* and *fill starch grains*.

Simple starch grains are such as occur singly. Compound starch grains occur in groups of two, three, four, five, six or more and are designated as two, three, four, five, six, etc., compound, according to the number of grains making up the group. Fill starch grains are small grains filling up the spaces between the larger grains in storage cells. These are common in commercial starches.

**Method of Examining Reserve Starches.**—Many of the reserve starches are used commercially, such as potato, corn, rice, maranta, oat, wheat, sago, tapioca, etc., and it frequently becomes necessary for the microscopist to determine their purity or their presence in a sample of food or drug. The following characteristics should be noted in determining the identity or source of the starch.

1. The shape of the grain.
2. Whether simple or compound or both; if compound, the number or range in numbers of grains composing it.
3. The size of the grain in microns.
4. The position of the hilum, if distinct; whether central or eccentric (outside of the center).
5. The shape of the hilum and the degree to which it is often fissured.
6. The nature of the lamellæ, whether distinct or indistinct; if distinct whether concentric (surrounding the hilum) or eccentric (apparently ending in the margin and not surrounding the hilum), or both, as in potato starch.
7. The color of the grains when stained with dilute iodine solutions; whether indigo, blue, purple, red or yellowish-red, etc.
8. The appearance under polarized light.
9. The temperature at which the paste is formed.
10. The consistency of the paste.

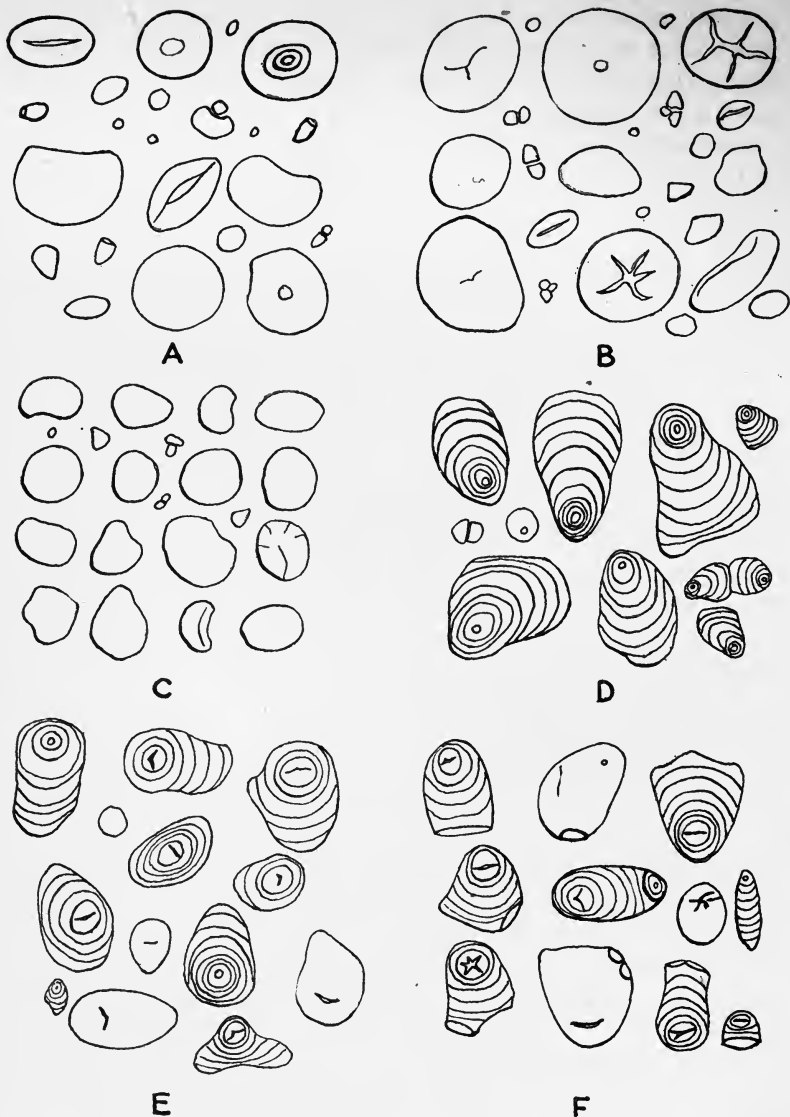

FIG. 36.—A, wheat starch grains; B, rye starch; C, barley starch; D, potato starch; E, Maranta starch; F, Sago starch. . Explanation in text.

## CHARACTERISTICS OF IMPORTANT COMMERCIAL STARCHES

**Potato Starch** (*Solanum tuberosum*)

Mostly simple, conchoidal or ellipsoidal, with occasional spheroidal and two- to three-compound grains.

Size: 5 to 125 $\mu$

Hilum: circular, at smaller end of grain.

Lamellæ: concentric and eccentric.

Polarization cross very distinct; beautiful play of colors with selenite plate.

**Maranta Starch** (*Maranta arundinacea*)

Ellipsoidal to ovoid.

Simple.

Size: 10 to 65 $\mu$ .

Hilum: a transverse or crescent-shaped cleft in center or near broad end of grain.

Lamellæ: usually indistinct.

Polarization cross very distinct; fine play of colors with selenite plate.

**Corn Starch** (*Zea Mays*)

Polygonal to rounded.

10 to 35 $\mu$ . Most grains over 15 $\mu$  in diameter.

Simple.

Hilum: circular or a two- to five-rayed cleft.

Lamellæ: indistinct.

Polarization cross distinct but no marked play of color with selenite plate.

**Rice Starch** (*Oryza sativa*)

Polygonal..

2 to 10 $\mu$  in diameter.

Simple or two- to many-compound.

Hilum: usually indistinct, occasionally a central cleft.

Lamellæ: indistinct.

Polarization cross distinct but no play of colors with selenite plate.

**Wheat Starch** (*Triticum sativum*)

Circular grains appearing lenticular shaped on edge view; simple.

Large grains 28 to 45 $\mu$  in diameter.

Hilum: central, appearing as dot, but usually indistinct.

Lamellæ: generally indistinct, when present concentric.

Polarization cross indistinct; no play of colors with selenite plate.

**Rye Starch** (*Secale cereale*)

Grains having a similar shape to those of wheat starch but many larger; simple.

Large grains 20 to 52 $\mu$  in diameter.

Hilum: a star-shaped central cleft or indistinct in some grains.

Lamellæ: concentric.

Polarization cross distinct.

**Barley Starch** (*Hordeum distichon*)

Grains having a similar shape to those of wheat starch but frequently tending to bulge on one side and so appear sub-reniform; large grains smaller; simple.

Grains appear elliptical to lemon shaped in edge view. Large grains usually 18 to 25 $\mu$ , occasionally up to 30 $\mu$  in length.

Hilum: centric or circular or cleft, often indistinct.

Lamellæ: concentric, often indistinct.

Polarization cross distinct.

**Buckwheat Starch** (*Fagopyrum esculentum*)

Grains simple and compound.

Simple grains polygonal or rounded polygonal.

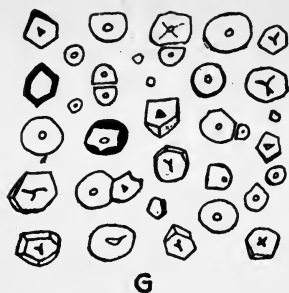

G

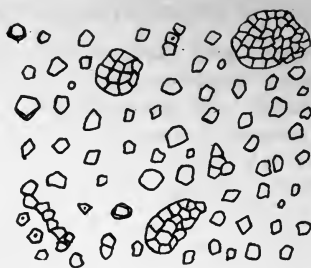

H



I

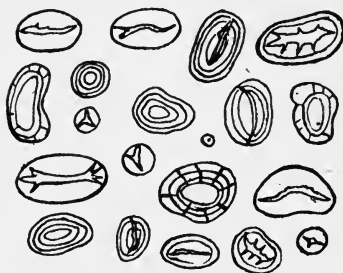

J

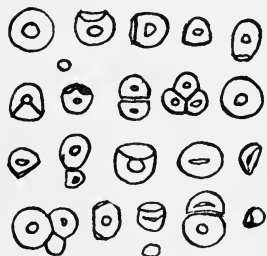

K

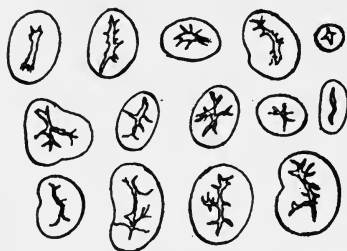

L

FIG. 37.—G, corn starch; H, rice starch; I, corn dextrin; J, pea starch; K, cassava starch; L, bean starch. Explanation in text.

Compound grains more or less rod-shaped.

2 to  $15\mu$  in diameter.

Hilum: central.

Lamellæ: generally indistinct.

Polarization cross distinct.

**Cassava Starch** (*Manihot utilissima*)

Grains rounded, truncated on one side.

Simple or two- to three- or four- to eight-compound.

6 to  $35\mu$  in diameter.

Hilum: central, circular or triangular with radiating clefts frequently.

Lamellæ: indistinct.

Polarization cross prominent.

**Bean Starch** (*Phaseolus vulgaris*)

Ovoid, ellipsoidal or reniform shaped-simple grains, occasionally obscurely 3- or 4-sided.

25 to  $60\mu$  in length. Generally from  $30-35\mu$ .

Hilum: central, elongated with branching clefts.

Lamellæ: distinct, concentric. In some indistinct.

Polarization crosses shaped thus, X

**Pea Starch** (*Pisum sativum*)

Oval-oblong, elliptical sub-reniform.

$15-51\mu$  in length. Generally from  $20-40\mu$ .

Hilum: similar to that of bean starch but less cleft or simply elongated.

Lamellæ: distinct, concentric.

Polarization crosses similar to bean starch.

**Canna Starch** (*Canna edulis* and other species of *Canna*)

Broadly elliptical, flattened, with beak or obtuse angle at one end.  $50$  to  $135\mu$  in length.

Hilum: excentric near narrower end.

Lamellæ: concentric and excentric.

Polarization cross very distinct; fine play of colors with selenite plate.

**Sago Starch** (*Metroxylon Sagu*)

Ovoid, muller shaped, or irregularly 3 or 4 sided with rounded angles.

Some more or less gelatinised.

Simple or 2, 3 or 4-compound

$30-60\mu$  long.

Hilum: eccentric often altered by gelatinisation.

Lamellæ: Excentric and concentric.

Polarization cross distinct.

4. **Dextrin.**—Dextrin is a carbohydrate made from starch (chiefly from corn or potato starch) by the application of heat (yellow dextrin) or by treatment with both heat and acids (white dextrin). It forms a paste with water, the yellow variety tending to swell up and dissolve much more readily than the white. When examined microscopically in alcohol mounts, the grains, while conforming in general outline to those of the type of starch from which the dextrin was prepared, nevertheless show more conspicuous striations and clefts. Corn dextrin shows distinct striations, whereas striations

in corn starch are absent. The grains take on a red coloration with iodine solutions.

5. **Amylodextrin.**—This is a carbohydrate intermediate in properties between starch and dextrin. It occurs in the form of small irregularly shaped granules, in Mace, that take on a reddish brown to reddish violet color with iodine solutions.

6. **Inulin.**—Inulin is a carbohydrate isomeric with starch which has the chemical formula of  $C_{12}H_{20}O_{10}$ . It is found dissolved in the cell sap of many plants, especially those of the *Compositæ*. If pieces of a plant part containing this substance be placed directly in alcohol for at least a week, then sectioned and mounted in alcohol, sphærocrystals of inulin will be seen applied to the walls of the cells. When these sections are treated with a 25 per cent. solution of alpha naphthol and 2 or 3 drops of strong  $H_2SO_4$ , the sphærocrystals will dissolve with a violet color. Fehling's solution is not reduced by inulin.

7. **Hesperidin.**—Hesperidin is a glucoside having the chemical formula of  $C_{21}H_{26}O_{12}$ . Like inulin it occurs in solution within the cell sap. It is found in abundance in the Rutaceæ family but occurs in many other plants. If sections of alcoholic material containing this substance such as Buchu leaves or unripe orange peel, are mounted in alcohol and examined, sphærocrystals will be seen. If these are then treated with a drop of alpha naphthol solution and 2 or 3 drops of strong  $H_2SO_4$ , they dissolve with a yellow color. The same coloration is evident when 5 per cent. solution of KOH is substituted for the alpha naphthol and  $H_2SO_4$ .

8. **Strophanthin.**—This is a glucoside occurring in the cell sap of the endosperm of *Strophanthus Kombe*, *S. hispidus* and other species of *Strophanthus*. If sections of fresh *Strophanthus* seeds are mounted in a drop of water and then transferred to a drop of concentrated  $H_2SO_4$ , the cells containing strophanthin will assume a bright green color.

9. **Salicin.**—Salicin is a glucoside occurring in the cell sap of the bark and leaves of the Willows and Poplars. Sections of these mounted in concentrated  $H_2SO_4$  will show a red coloration in the cells containing this substance. If water be added a red powder is thrown down.



10. **Saponin**, another glucoside, found in Soap Bark, Senega, Saponaria and other drugs also takes a red color with strong  $H_2SO_4$ .

11. **Coniferin** is a glucoside, occurring in the cell sap of the spruce, pine, and other plants of the *Coniferæ*. If sections containing it are first treated with a solution of phenol and then with sulphuric acid, the cells containing it take on a deep blue color.

12. **Digitoxin**, a glucoside found in the leaves of *Digitalis purpurea*, is colored green with hydrochloric acid.

The *glucosides* are very numerous. Those listed above represent but a few examples. They arise in the cell sap of plants containing them as products of constructive metabolism (anabolism) and are thought by many to have the function of protecting plants against the ravages of animals. Some are known to serve as reserve food. All glucosides are characterized by the property of being split up into glucose and other substances when acted upon by a ferment, dilute acids or alkalis.

13. **Alkaloids**.—Chemically, these are basic carbonaceous amines which like glucosides are products of metabolism. Their method of formation in plants is uncertain. Some hold that they are katabolic products, resulting from the breaking down of tissues, while others believe them anabolic in character. They undoubtedly serve as defensive agents in plants containing them on account of their bitter taste and poisonous properties.

#### *Properties of Alkaloids*

Alkaloids are invariably found in combination with acids forming salts which dissolve in water or alcohol. They are composed of carbon, hydrogen and nitrogen. Some contain oxygen. They are precipitated from saline solutions by the addition of alkalis. They are mostly colorless and crystallizable. They can be precipitated by one or more of the following alkaloidal reagents: tannic acid, gold chloride, phospho-molybdic acid, picric acid and potassio-mercuric iodide.

#### *Examples of Alkaloids*

**Strychnine**.—This alkaloid, with a chemical formula of  $C_{21}H_{22}N_2O_2$ , occurs in the seeds of *Strychnos nux vomica*, *Strychnos Ignatii* and other species of *Strychnos*. When sections of strychnine con-

taining seeds, previously treated with petroleum ether and absolute alcohol, are mounted in a solution of 1 Gm. ammonium vanadate in 100 mils of sulphuric acid, they take on a violet-red color which later changes to brown.

**Veratrine.**—This alkaloid, with a composition of  $C_{37}H_{53}NO_{11}$ , is found in various parenchyma cells of *Veratrum album*. If sections of the rhizome or roots are mounted in 2 drops of water and a drop of concentrated  $H_2SO_4$  and examined microscopically on a glass slide, the cell contents and walls of the *cells* which contain this substance first take a yellow color which soon changes to an orange-red and then to a violet.

**Nicotine.**—This is a volatile alkaloid having the formula of  $C_{10}H_{14}N_2$  which is found in the *Nicotiana* genus of the Nightshade family. Sections of tobacco leaves or stems mounted in dilute Lugol's solution will show first a carmine-red color and then a reddish-brown precipitate which in time loses its color.

**Caffeine.**—This alkaloid, with a formula of  $C_8H_{10}N_4O_2 + H_2O$ , occurs in *Thea*, *Coffea*, *Cola*, *Sterculea*, *Ilex* and *Neea*. If thin sections containing it are placed on a glass slide in 2 or 3 drops of concentrated hydrochloric acid and gently heated and then 2 or 3 drops of gold chloride solution are added, the sections then pushed to the side and the liquid allowed to evaporate, slender yellowish branching needles of caffeine gold chloride will be seen to separate.

**Cocaine.**—This narcotic alkaloid, having the formula  $C_{17}H_{21}NO_4$ , is found in the leaves of *Erythroxylon Coca* and *E. Truxillense*. If sections of these leaves are prepared in the same manner as indicated for those containing Caffeine, but platinum chloride solution substituted for that of gold chloride, large feathers or plumes of cocaine-chloro-platinate will be seen separating.

**Aconitine** ( $C_{33}H_{43}NO_{12}$ ) is found in various parts of *Aconitum Napellus*. It is particularly abundant in the tuberous root of this plant. If sections of aconite root are treated on a glass slide with solution of potassium permanganate, a red precipitate of aconitine permanganate will appear in the cells containing this alkaloid.

**Colchicine** ( $C_{22}H_{25}NO_6$ ).—This alkaloid occurs in the corm and seeds of *Colchicum autumnale*. It is very abundant in the cells surrounding the fibro-vascular bundles of the corm. If a section of

either corm or seed be treated with a mixture of 1 part of  $H_2SO_4$  and 3 parts of  $H_2O$ , the cells containing colchicine will be colored yellow. If a crystal of  $KNO_3$  then be added the color will change to a brownish-violet.

10. **Gluco-alkaloids.**—These are compounds intermediate in nature between alkaloids and glucosides, having characteristics of each. To this group belongs solanine ( $C_{28}H_{47}NO_{11}$ ) which is found in *Solanum nigrum*, *Solanum Dulcamara*, *Solanum carolinense* and other species of the *Solanacea*. When sections of those plant parts which contain this constituent are mounted in a solution of 1 part of ammonium vanadate in 1000 parts of a mixture of 49 parts of sulphuric acid with 18 parts of water, the cells containing solanin take on a yellow color which changes successively to orange, various shades of red, blue-violet, grayish-blue and then disappears.

14. **Asparagine** ( $C_4H_8N_2 + H_2O$ ).—This is an amino compound of crystalline nature which occurs widely in the plant kingdom. It has been found in certain of the slime molds and fungi, in the roots of *Althæa officinalis* and *Atropa belladonna*, in young shoots of *Asparagus*, in the seeds of *Castanea dentata*, in the tubers of *Solanum tuberosum* and varieties of *Dahlia*, and is known to play an important part in metabolism. Stevens claims that proteids are reduced for the most part to asparagine during seed germination.<sup>1</sup> If thick sections are cut from a plant part containing this substance and mounted in alcohol, rhombohedral crystals of asparagin in the form of plates will be deposited upon the evaporation of the alcohol. If to these a few drops of a saturated solution of asparagine are added the crystals already formed will increase in size. To get satisfactory results the saturated solution must be of the same temperature as the mount.

15. **Calcium Oxalate.**—This substance occurs in many plants always in the form of crystals. It is apparently formed by the reaction of salts of calcium, which have found their way into the cell sap from the soil, with oxalic acid which is manufactured by the plant. Calcium oxalate crystals dissolve readily in mineral acids without effervescence. They are insoluble in acetic acid or water.

<sup>1</sup> Stevens' Plant Anatomy, 3d Edit., p. 189.

These crystals are classified according to form and belong either to the monoclinic or tetragonal system (See Fig. 38).

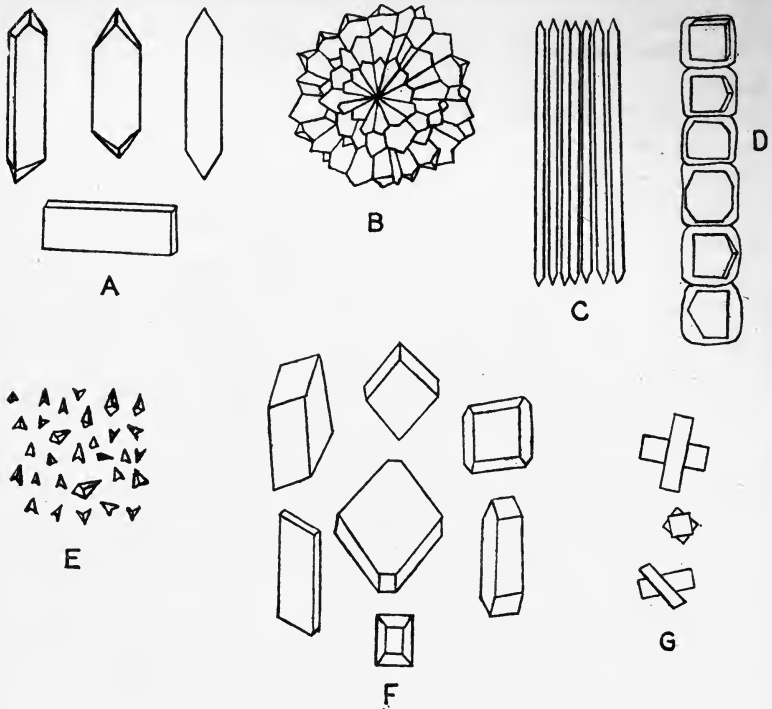

FIG. 38.—Various forms of calcium oxalate crystals. A, styloids from the bark of *Quillaja saponaria*; B, rosette aggregate from rhizome of *Rheum officinale*; C, raphide from the bulb of *Urginea maritima*; D, crystal fiber as seen in longitudinal section in either the xylem or phloem regions of *Glycyrrhiza*; E, micro-crystals (crystal sand) isolated from the parenchyma of *Belladonna* root; F, monoclinic prisms; and G, twin-crystals from leaves of *Hyoscyamus niger*. All highly magnified.

*Crystals belonging to the Monoclinic System and Examples of Drugs Containing them:*

1. Solitary—*Hyoscyamus*, *Acer Spicatum*, *Viburnum Prunifolium*.
2. Rosette Aggregates—*Althæa*, *Gossypii Cortex*, *Stramonium*, *Granatum*, *Rheum*, *Feniculum*, *Viburnum*.
3. Columnar (Styloids)—*Quillaja*.

4. Raphides—Convallaria, Sarsaparilla, Veratrum, Scilla, Phytolacca.

5. Micro-crystals (Crystal sand)—Belladonnæ Radix, Cinchona, Stramonium, Phytolacca, Capsicum.

6. Crystal Fibers—Cascara Sagrada, Prunus Virginiana, Glycyrrhiza, Aspidosperma.

7. Membrane Crystals—Aurantii Dulcis Cortex, Limonis Cortex, Condurango.

*Solitary crystals*, usually in the form of rhombohedra, occasionally in twin crystals, occur as sharp angular bodies, each one often completely filling up the lumen of a cell.

*Rosette aggregates* consist of numerous small prisms or pyramids, or hemihedral crystals arranged around a central axis, appearing like a rosette or star.

*Columnar crystals* or styloids are elongated prisms.

*Raphides* are groups of acicular or needle-shaped crystals, which occur in long thin-walled cells containing mucilage. They are more frequently found in Monocotyledons than in any other plant group. *Micro-crystals* (sphenoidal micro-crystals or crystal sand) are minute arrow-shaped or deltoid forms completely filling the parenchyma cells in which they occur and giving these a grayish-black appearance.

*Crystal fibers* are longitudinal rows of superimposed parenchyma cells each of which contains a single monoclinic prism or rosette aggregate. Crystal fibers are found adjacent to sclerenchyma fibers such as bast or woody fibers.

*Membrane crystals* are monoclinic prisms, each of which is surrounded by a wall or membrane. In the process of formation a crystal first is formed in the cell sap and then numerous oil globules make their appearance in the protoplasm surrounding it; later some of the walls of the cell grow around the crystal and completely envelop it.

16. **Cystoliths.**—Cystoliths are clustered bodies formed by the thickening of the cell wall at a certain point and subsequent in-growth which latter forms a cellulose skeleton consisting of a stalk and body. Silica is subsequently deposited on the stalk while calcium carbonate is piled up on the body in layers, forming an irregu-

lar spheroidal or ellipsoidal deposit. These structures are abundantly found in the plants of the Nettle Family and constitute a leading peculiarity of the same (see Fig. 87).

Hair cystoliths differ from the average type in that they are devoid of a stalk. Such are seen in the non-glandular hairs of *Cannabis sativa*.

The calcium carbonate incrustation of a cystolith dissolves with effervescence on the addition of a mineral or organic acid.

17. **Silica.**—Silica ( $\text{SiO}_2$ ) occurs in a number of plants either as an incrustation in the cell wall as in Diatoms, the *Equisetineæ* and *Gramineæ* or more rarely in the form "silica bodies" such as are found in certain Palms, Orchids and *Tristicha*. It is insoluble in all the acids except hydrofluoric. It may be obtained in pure form by placing tissue containing it in a drop or two of concentrated sulphuric acid and after a time treating with successively stronger solutions of chromic acid (starting with 25 per cent.) and then washing with water and alcohol.

18. **Tannins.**—Tannins are amorphous substances occurring in plants having an astringent taste, and turning dark blue or green with iron salts. They occur in greatest quantity in the bark of exogens, and in gall formations. They are soluble in water, alcohol glycerine, and a mixture of alcohol and ether. They are almost insoluble in absolute ether and chloroform. They give insoluble precipitates with organic bases such as alkaloids and with most of the salts of the heavy metals.

According to their behavior with solution of iron chloride or other soluble iron salts two kinds of tannic acid are recognized: (a) a form of tannic acid giving a blue color, as that which is found in Rhus, Castanea, Granatum, Galla, etc.; (b) another tannic acid producing a green coloration, as that found in Krameria, Kino, Mangrove bark, Quercus, Catechu, etc.

If sections are placed in a 7 per cent. solution of copper acetate for a week or more, then placed on a slide in 0.5 per cent. aqueous solution of ferric chloride, and after a while washed with water and mounted in glycerin, an insoluble brownish precipitate will be produced in those cells containing tannin.

19. **Proteins.**—Proteins are complex nitrogenous substances forming the most important of the reserve foods of plants. They are found in all the living and many of the dead cells of plants, although most abundant in seeds. Protoplasm, itself, is composed largely of these substances. They all contain carbon, hydrogen, oxygen, nitrogen and sulphur, and many contain in addition phosphorus. They are formed by the addition of nitrogen, sulphur and frequently phosphorus to elements of grape sugar. The nitrogen, sulphur and phosphorous elements are obtained from nitrates, sulphates and phosphates which are dissolved in the water taken in through the roots. The names of proteins recorded may be found by the hundreds. These are grouped into chemical classes, the most important of which from the standpoint of their occurrence in plants are the *globulins*, *albumens*, *glutelins*, *nucleins*, and *gliadins*. Of these the *globulins* are found most extensively. Globulins are insoluble in water but soluble in sodium chloride solutions. They do not coagulate upon the application of heat.

Albumens are soluble in water and coagulate with heat.

Glutelins are insoluble in water, sodium chloride solution and strong alcohol.

Gliadins are nearly or wholly insoluble in water but soluble in 70 to 90 per cent. alcohol.

Nucleins are insoluble in water but soluble in alkaline solutions.

The following tests are of value in determining the presence of proteins.

Lugol's solution stains proteins yellow or brown.

Concentrated nitric acid stains proteins yellow. This color becomes deeper upon the addition of ammonia water.

Million's reagent stains proteins a brick-red.

Concentrated solution of nickel sulphate colors proteins yellow or blue.

If sections are placed for an hour or two in a solution of 1 Gm. of sodium phospho-molybdate in 90 Gm. of distilled water and 5 Gm. of nitric acid, the proteid substances appear as yellowish granules.

The *globulins* (phytoglobulins) frequently occur in bodies called "aleurone grains."

## ALEURONE GRAINS

Aleurone grains are small bodies found in seeds particularly those containing oil, and like starch grains often are characteristic of the genus or species. Each aleurone grain consists of a ground substance (composed of amorphous proteid matter soluble in water, dilute alkali or acid), in which are usually embedded one or more *phyto-globulins* (insoluble in cold water, but soluble in less than 1 per cent. solution of an alkali, in dilute HCl and acetic acid), one or more transparent globular *globoids* composed of Ca and Mg phosphate

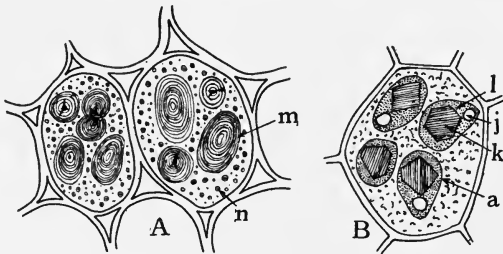

FIG. 39.—To show aleurone grains. *A*, cells from cotyledon of seed of garden bean; *n*, aleurone grains; *m*, starch; *B*, cells from endosperm of castor bean; *a*, *a*, aleurone grain; *l*, ground substance; *k*, phytoglobulin; *i*, globoid. (*A*, After Sachs; *B*, after Frank.)

(insoluble in water and dilute potash solution but soluble in 1 per cent. acetic acid solution), and frequently a crystal of *calcium oxalate*, the whole being enclosed by a *protoplasmic membrane* (soluble in water). (Fig. 39*B*.)

The proteins insoluble in the cell-sap water are made soluble for translocation by means of *proteolytic enzymes* which change them into proteoses and peptones.

20. **Mucilages and gums** are those substances occurring in plants which are soluble in water or swell in it, and which are precipitated by alcohol.

Mucilage is formed in plants in several ways, viz.; either as a product of the protoplasm, as a disorganization product of some of the carbohydrates, as a secondary thickening or addition to the cell wall, or as a metamorphosis of it. In the first two cases the mucilage is called *cell-content mucilage*; in the last two, *membrane mucilage*.



Mucilage is stored as reserve food in the tubers of Salep and many other Orchids and also in the seeds of some species of the Leguminosæ.

**Cell-content mucilage** has been found in the leaves of *Alœ*, the rhizomes of *Triticum*, the bulb scales of *Squill* and *Onion* and in certain cells of many other Monocotyledons, especially those containing raphides.

**Membrane mucilage** has been observed in *Barosma*, *Ulmus*, *Althœa*, *Linum*, *Astragalus*, and *Acacia* species, in the Blue-green Algæ, and many of the Brown and Red Algæ.

When mucilage is collected in the form of an exudate from shrubs and trees it constitutes what is termed a *gum*. Many of these gums are used in pharmacy, medicine and the arts. The three most important from a pharmaceutical standpoint are: **Acacia**, yielded by *Acacia Senegal* and other species of *Acacia*; **Tragacanth**, yielded by *Astragalus gummifer* and other Asiatic species of *Astragalus*; and **Cherry Gum**, obtained from *Prunus Cerasus* and its varieties.

Mucilage may be demonstrated in plant tissues containing it by placing sections of these in a deep blue solution of methylene-blue in equal parts of alcohol, glycerin and water on a glass slide, allowing them to remain in the solution for several minutes, then draining off the stain and mounting in glycerin. Those cells containing mucilage will exhibit bluish contents.

21. **Fixed Oils and Fats.**—These are fatty acid-esters of glycerin which are found in the vacuoles of cells or formed with the cell walls from which they may be liberated as globules upon treating sections with chloral hydrate or sulphuric acid or heating them. They are quite soluble in ether, chloroform, benzol, acetone and volatile oils but insoluble in water, and, with the exception of castor oil, insoluble in alcohol. They are readily distinguished from the volatile oils in that they leave a greasy stain upon paper which does not disappear. Fixed oils and fats take a brownish to black color with osmic acid, a red color with alkannin or Sudan III and a blue color with cyanin. In *Vaucheria*, the Diatoms and a few of the other Thallophytes, fixed oil is formed in the chromatophores instead of starch as the first visible product of photosynthesis. In higher plants it is generally found in storage regions, such as the

parenchyma of seeds, fruits and the medullary ray cells and parenchyma of barks, roots and rhizomes.

22. **Volatile Oils.**—These are volatile odoriferous principles found in various parts of numerous plants which arise either as a direct product of the protoplasm or through a decomposition of a layer of the cell wall which Tschirch designates a “resinogenous layer.” They are readily distilled from plants, together with watery vapor, are slightly soluble in water, but very soluble in fixed oils, ether, chloroform, glacial acetic acid, naphtha, alcohol, benzin and benzol. They leave a spot on paper which, however, soon disappears. They respond to osmic acid, alkannin, Sudan III, and cyanin stains similar to the fixed oils and fats.

Volatile oils may be grouped into four classes:

A. **Pinenes or Terpenes**, containing carbon and hydrogen and having the formula of  $C_{10}H_{16}$ . Examples: Oil of Turpentine and various other volatile oils occurring in coniferous plants.

B. **Oxygenated oils**, containing carbon, hydrogen and oxygen. Examples: Oil of cassia and other cinnamons.

C. **Nitrogenated oils**, containing carbon, hydrogen and oxygen with nitrogen (from HCN). Example: Oil of Bitter Almonds.

D. **Sulphurated oils**, containing carbon, hydrogen and sulphur. Example: Volatile oil of mustard.

23. **Resins, Oleoresins, Gum Resins, and Balsams.**—These substances represent products of metabolism in many plants which are formed either normally as Turpentine, Asafœtida, Mastiche, etc., or as a result of pathological processes through injury to the plant tissues as Styrax, Benzoin, Balsam of Tolu and Peru, etc. They occur usually in special cavities such as secretion cells, glands, or secretion reservoirs.

**Resins** are insoluble in water but mostly soluble in alcohol. They combine with alkalię to form soap. Many of them are oxidized oils of plants. Examples: Guaiacum, Resina.

**Oleoresins** are mixtures of oil and resin. Examples: Terebinthina, Terebinthina Canadensis.

**Gum resins** are natural compounds of resin, gum and oil. Examples: Asafœtida, Myrrha, Cambogia.

**Balsams** are mixtures of resins with cinnamic or benzoic acid or both and generally a volatile oil. Examples: Balsamum Tolu-  
tanum, Styrax, Balsamum Peruvianum.

If sections of a resin containing plant part are placed in a saturated aqueous solution of copper acetate for a week or two and mounted in dilute glycerin, the resin will be stained an emerald green.

24. **Pigments.**—These are substances which give color to various plant parts in which they are found. They occur either in special protoplasmic structures, as chloroplasts, chromoplasts or chromatophores, or dissolved in the cell sap. Of the pigments named the following will be considered: Chlorophyll, Xanthophyll, Chromophyll, Etiolin, Anthocyanin, Phycocyanin, Phycophæin, and Phycærythrin.

**Chlorophyll** is the yellowish-green pigment found in the chloroplastids or chromatophores of leaves or other green parts of plants. Its composition is not definitely known although it yields products similar to the hæmoglobin of the blood when decomposed. Iron is known to be essential to its formation. If an equal portion of xylene be added to a fresh alcoholic solution of chlorophyll and the mixture shaken, the chlorophyll in solution will break up into a yellowish and greenish portion. The greenish portion dissolves in the xylene which rises forming the upper stratum, while the yellowish portion dissolves in the alcohol forming the lower stratum. To this isolated greenish portion of chlorophyll has been given the name of "chlorophyllin" while the yellowish portion has been designated "xanthophyll."

Chlorophyllin when examined spectroscopically produces absorption bands in the red, orange, yellow and green of the spectrum, the broadest and most distinct band being in the red.

**Chromophyll** also called "*xanthophyll*" and "*carotin*" is the yellow or orange pigment found in chromoplastids. By some the term carotin is limited to the orange pigment found in the carrot. Sulphuric acid forms a blue color with chromophyll.

**Etiolin** is a pale yellow pigment which appears when green plants are kept for some time in darkness. It is probably identical with xanthophyll.

**Anthocyanins** are applied to the blue, purple and red pigments which occur in the cell sap. The character of the color is claimed to be due to the alkalinity or acidity of the cell sap.

**Phycocyanin** is the blue pigment found in the blue-green algæ, associated with chlorophyll. It is soluble in water.

**Phycophæin** is the brown pigment found in the brown algæ.

**Phycerythrin** is the red pigment found in many of the red algæ.

The last two are always associated with chlorophyll but frequently conceal it.

25. **Latex**.—This is an emulsion of varying composition and color found in special passages, as latex cells and laticiferous vessels of many plants. It may contain starch, sugar, proteid, oil, enzymes, tannins, alkaloids, gum, resins, caoutchouc and mineral salts. The color may be absent as in *Oleander*; whitish as in *Asclepias*, *Papaver*, *Hevea*, and *Apocynum*; yellowish to orange as in *Celandine*, or red as in *Sanguinaria*.

Chlor-zinc-iodine solution imparts to latex a wine red color.

The latex of the following plants is of value to pharmacy and the arts:

*Papaver somniferum* and its variety *album* which yields **Opium**. That from the unripe capsules is alone used for this drug.

*Palaquium Gutta* which yields **Gutta Percha**.

*Hevea* species, *Ficus elastica*, *Landolphia* species, *Castilloa elastica*, *Hancornia speciosa*, *Forsteronia* species, *Funtumia elastica* and *F. africana*, *Manihot* species, *Clitandra* species and various species of *Euphorbia* furnish most of the **Rubber** of commerce.

*Lactuca virosa* and other species of *Lactuca* yield the drug **Lactucarium**.

26. **Enzymes**.—An *enzyme* or *ferment* (according to Hepburn) is a soluble organic compound of biologic origin functioning as a thermolabile catalyst in solution. Ostwald has defined a catalyst as an agent which alters the rate of a reaction without itself entering into the final product, or which does not appear to take any immediate part in the reaction, remains unaltered at the end of the reaction and can be recovered again from the reaction product unaltered in quantity and quality. The biologic catalysts (enzymes)

differ from the inorganic catalysts in that they are sensitive to heat and light. According to Haas and Hill they are destroyed at 100°C. and most of them cannot be heated safely above 60°C. Enzymes are soluble in water, glycerin or dilute saline solutions. They are stimulated to activity by substances known as "activators" and their activity is checked by other substances called "paralyzers." Frequently the paralyzers consist of products of enzyme action. Cold inhibits and warmth accelerates enzyme action. Moisture must always be present for enzymic activity.

### CLASSIFICATION OF ENZYMES

A. According to Diffusibility through Cell Wall.

**Endocellular:** Those that cannot diffuse out of the cell. Example: Zymase of Yeast.

**Extracellular:** Those that can diffuse out of the cell. Example: Invertase of Yeast.

B. According to Kind of Substances Acted upon and Transformed.

#### 1. Carbohydrate enzymes:

**Diatase** found in the germinating seeds of barley and other grains and in *Aspergillus oryzae*, etc., converts starch to maltose and dextrin.

**Invertase**, secreted by yeasts, and found in younger parts of higher plants, transforms cane sugar, producing dextrose and levulose.

**Maltase**, found in malt and *Saccharomyces octosporus*, transforms maltose to dextrose.

**Trehalase**, found in *Polyporus*, hydrolyzes trehalose to dextrose.

**Cytase**, found in *Nux Vomica* seeds, in barley, dates, etc., decomposes hemicellulose and cellulose to galactose and mannose.

**Lactase**, found in Kephir grains, hydrolyzes lactose to dextrose and galactose.

**Inulase**, found in Compositaceous plants, transforms inulin to levulose.

**Zymase**, found in yeast, hydrolyzes glucose (dextrose and levulose) to alcohol and carbon dioxide.

## 2. Fat and Oil Ferment :

**Lipase** splits up fats and oils into fatty acids and glycerin. It is found in various mildews, molds and numerous oily seeds and other fatty-oil storage regions of higher plants.

## 3. Proteinaceous Ferments :

**Pepsin** converts proteids into proteoses and peptones.

**Trypsin**, found in yeast, *Boletus edulis*, *Amanita* species, etc., resolves proteins to peptones and amino-acids.

**Bromelin**, found in the fruit of the Pineapple and Papayin (Papain), found in the latex of the fruit of the Papaw, act similarly to trypsin.

**Nepenthin**, found in the pitchers of *Nepenthes* species, acts similarly to pepsin.

## 4. Glucoside Ferments :

**Emulsin** (synaptase), found in the seeds of the Bitter Almond, Cherry Laurel leaves, in the barks of the Wild Black Cherry and Choke Cherry and in other Rosaceous plant parts, in *Manihot utilissima*, *Polygala* species, etc., hydrolyzes the glucoside present (either amygdalin or l-mandelonitrile glucoside) to hydrocyanic acid, benzaldehyde and glucose.

**Myrosin** (myronase), found in the seeds of *Brassica nigra* and other members of the *Cruciferae*, converts the glucoside, Sinigrin, into ally-iso-sulphocyanide and glucose.

**Rhamnase**, found in *Rhamnus Frangula* and probably other species of *Rhamnus*, hydrolyzes the glucoside frangulin to rhamnose and emodin.

**Gaultherase**, found in *Gaultheria procumbens* and other Ericaceous plants, resolves the glucoside, gaultherin, to methyl-salicylate and glucose.

## CELL WALLS

The cell walls of plants make up the plant skeleton. They are all formed by the living contents of the cells (protoplasts) during cell-divisions. In most plants the cell wall when first formed consists of *cellulose*,  $(C_6H_{10}O_5)_n$ , a carbohydrate, or closely allied substances. It may remain of such composition or become modified to meet cer-

tain functions required of it. Thus, in the case of outer covering cells as epidermis and cork, whose function is that of protecting the underlying plant units, the walls become infiltrated with cutin and suberin, waxy-like substances, which make them impermeable to water and gases, as well as protect them against easy crushing. Again, in the case of stone cells and sclerenchyma fibers whose function is that of giving strength and support to the regions wherein found, the walls become infiltrated with lignin which increases their strength, hardness, and in the case of sclerenchyma fibers, their elasticity also. Moreover, in the case of the cells comprising the testa or outer seed coat of the pumpkin, squash, mustard and flax, etc., whose function is that of imbibing quantities of water, the walls undergo a mucilaginous modification.

**Growth in Area and Thickness.**—The cell wall when first formed is limited in both extent and thickness. As the protoplast within enlarges new particles are placed within the wall by the process called *intussusception*. This increases its area. New particles, also, are deposited on its surface which gradually increases its thickness. The latter process is known as *growth by apposition*.

VARIOUS KINDS OF CELL WALLS AND BEHAVIOR OF EACH TO MICRO-  
CHEMIC REAGENTS

| <i>Nature of wall</i>                         | <i>Where found</i>   | <i>Reagent and behavior toward same</i>  |
|---|--|--|
| Cellulose.....                                | Parenchyme cells, tri-<br>chomes such as<br>cotton, etc.                                   | Cuoxam dissolves it. Chlorzinc-<br>iodine solution imparts a blue or vio-<br>let color. Iodine solution followed<br>by sulphuric acid colors it blue.  |
| Lignocellulose<br>(Lignified wall).           | Woody parts of<br>plants, such as stem<br>cells, bast fibers,<br>wood fibers, etc.         | Phloroglucin with HCl imparts a red<br>color except to bast fibers of flax.<br>Corallin-soda solution imparts pink<br>color. Aniline sulphate with H <sub>2</sub> SO <sub>4</sub><br>colors it a golden-yellow. Chlorzinc-<br>iodine imparts a yellow color.               |
| Reserve cellulose                             | Found in certain seeds<br>such as nux vomica,<br>ignatia, ivory nut, date,<br>coffee, etc. | As for cellulose.  |
| Mucilaginous<br>modification of<br>cellulose. | In various parts of<br>plants.   | Alcoholic or glycerin solution of meth-<br>ylene-blue imparts a blue color.  |
| Suberized walls..                             | In cork, wounded<br>areas of plants, endo-<br>dermis.                                      | Alcoholic extract of chlorophyll, in the<br>dark, imparts a green color. Alcannin<br>and Sudan III impart a red coloration.<br>Converted into yellowish drop-<br>plets and granular masses upon heat-<br>ing with a strong solution of KOH.<br>Sulphuric acid is resisted. |
| Cutinized walls..                             | Forming outer walls<br>of many epidermal<br>cells.   | As for suberized walls.  |
| Callus of sieve<br>plates.                    | Plates of sieve tubes.   | Corallin-soda solution imparts pink<br>color.  |
| Silicified walls . .                          | Epidermis of Equi-<br>setaceæ, Gramineæ,<br>etc.; Diatoms.                                 | Soluble in hydrofluoric acid.  |



## CHAPTER VI

### PLANT TISSUES

A **tissue** is an aggregation of cells of common source, structure and function in intimate union.

#### THE TISSUES OF SPERMATOPHYTES AND PTERIDOPHYTES

The tissues of seed plants and pteridophytes are all derived from a fertilized egg (oöspore) which has undergone repeated divisions. At first either an apical cell arises or a mass of cells is formed which are essentially alike, but gradually we find that a division of labor has become operative setting aside many different groups of cells, each group of which has its particular rôle to perform in the economy of the whole. Each group of cells similar in source, structure and function is called a tissue. The tissues found in higher plants range from those whose component cells are more or less rounded, in a rapid state of division, and whose thin cellulose cell walls enclose a mass of protoplasm, devoid of vacuoles, or with exceeding small ones to those whose cells through various physical and chemical factors become compressed, elongated, and highly modified in respect to their contents and walls.

As was shown by Hanstein,<sup>1</sup> the embryo of Angiosperms, while still constituted of only a few cells in the process of division, becomes differentiated into three layers of cells which differ in their arrangement and direction of division; these were called by him, *Dermatogen*, *Periblem* and *Plerome*. In roots a fourth layer of cells is sometimes evident at the apex. This was termed by Janczewski<sup>2</sup> the *Calyptrogen* layer. These primary layers or groups of cells are called primary *meristems* or *generative tissues*. They are composed

<sup>1</sup> Hanstein, "Die Scheitelzellgruppe im Vegetationspunkt der Phanerogamen," Bonn, 1868.

<sup>2</sup> Am. Sci. Nat. 5 série, tom. xx.

of more or less rounded cells having delicate cell walls of cellulose which enclose protoplasm and nucleus and wherever found in living embryos are in a rapid state of division.

The generative tissues are found in the growing apices of plant organs, such as root, stem and leaf apex. By the division and redivisions of their cells they give rise to the mature or adult tissues of plants.

1. **Dermatogen** originates epidermal tissue and derivative structures such as stomata, non-glandular and glandular hairs, glands, and cork cambium.

2. **Periblem** originates cortex tissue, chlorophylloid cells (chlorenchyma) colloid cells (collenchyma), strengthening cells (sclerenchyma), crystal cells (raphiderchyma) latex cells (lacterchyma), endodermis and cork cambium.

3. **Plerome** originates fibro-vascular bundles, fundamental tissue, pericambium and cambium.

According to structure the following tissues are found in various forms of higher plants:

- |                        |                                     |
|------------------------|-------------------------------------|
| 1. <b>Meristem</b>     | 7. <b>Cork</b>                      |
| 2. <b>Parenchyma</b>   | 8. <b>Laticiferous tissue</b>       |
| 3. <b>Collenchyma</b>  | 9. <b>Cribiform or sieve tissue</b> |
| 4. <b>Sclerenchyma</b> | 10. <b>Tracheary tissue</b>         |
| 5. <b>Epidermis</b>    | 11. <b>Medullary rays</b>           |
| 6. <b>Endodermis</b>   |                                     |

### MERISTEM

**Meristem**, frequently called embryonic tissue, is undifferentiated tissue composed of cells in the state of rapid division. It is found in the growing apices of roots, stems and leaves and is in these regions called *primary meristem*, since it is the first meristem to appear. Such meristem gives rise to the permanent or mature tissues of plants and retains the power of independent growth and capacity for division as long as the plant part survives which contains it. Meristem is also found in other regions of plant organs such as the cambium, cork cambium and pericambium and is there called *secondary meristem*. Secondary meristem loses with its development the power of division and independent growth.

## PARENCHYMA

**Parenchyma** or **Fundamental Tissue** is the soft tissue of plants, consisting of cells about equal in length, breadth and thickness (isodiametric) with thin cellulose cell walls enclosing protoplasm and a nucleus and frequently substances of a non-protoplasmic nature. There are four generally recognized types of parenchyma, viz.:

**Ordinary Parenchyma (Soft Ground Tissue, Fundamental Tissue).**—Next to the meristem this is the least modified of all plant tissues. It is generally composed of thin-walled cells, commonly polyhedral or spheroidal in form and often of approximately the same length, breadth, and thickness (isodiametric), the cell walls are composed of cellulose which is usually unmodified. Occasionally the outline of the cells is star-shaped, as in the Wood Rush or Pickereel Weed or the cells may be several times as long as wide, as in Pelargonium, etc. Moreover, markings may occur on the walls. These may be of the nature of pores, as in the parenchyma cells of the pith of the Elder or Sassafras, annular or reticulate thickenings, as in the Mistletoe, or spiral thickenings, as in certain Orchids. Protoplasm and a nucleus are always present, but in old cells are only seen as a thin layer pushed up against the cell wall. Ordinary Parenchyma may be seen composing the soft tissues of roots, stems, and barks.

**Assimilation Parenchyma (Chlorophyll or Chromophyll Parenchyma, Chlorenchyma).**—This form of parenchyma tissue is found in foliage leaves, floral leaves, in the outer region of young green stems and fruits. Its cells are thin walled and vary in shape from more or less isodiametric to irregular and elongated forms. The cells always contain chloroplasts or plastids, in whose pores may be found some other coloring substance.

**Conducting Parenchyma.**—This type of parenchyma functions in the rapid translocation of food materials to distant regions in the plant. It includes the *wood parenchyma cells* of the *xylem* which convey a portion of the crude sap (water with mineral salts in solution) and the *phloem parenchyma* (soft bast) which transports the elaborated sap (carbohydrate and proteid material in solution). Conducting parenchyma cells differ from those of ordinary paren-

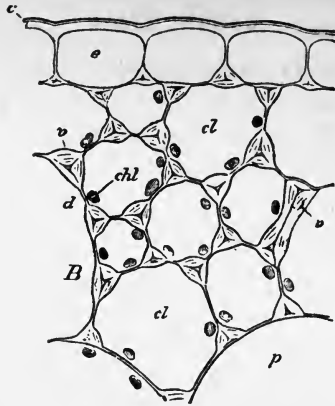

FIG. 40.—Transverse section of part of leaf-stalk of a begonia. *e*, Epidermis; *c*, cuticle; *B*, collenchyma, with walls thickened at the angles *v*, *chl*, chloroplasts. (Sayre after Vines.)

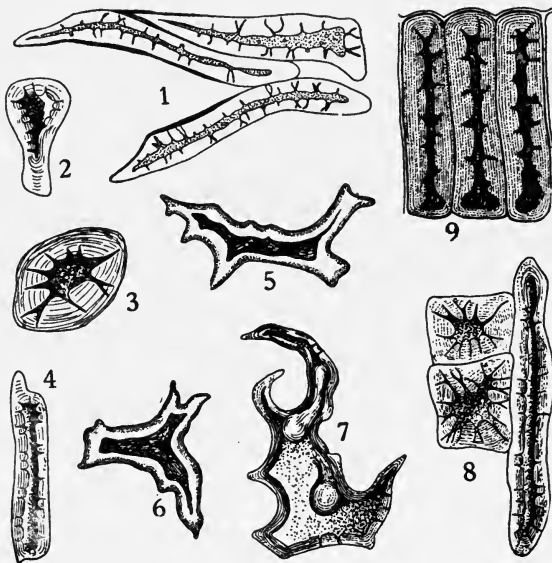

FIG. 41.—Stone cells from different sources. 1. From coffee; 2, 3, and 4, from stem of clove; 5 and 6, from tea leaf; 7, 8, and 9, from powdered star-anise seed. (Stevens, after Moeller).

chyma in being usually more elongated and in conducting soluble food materials with greater celerity.

**Reserve Parenchyma.**—This resembles ordinary parenchyma in many particulars of structure but differs from it mainly by its cells being filled with starch, protein crystals, or oil globules. It is usually found in seeds, fleshy roots, or underground stems such as tubers, corms, and bulbs.

**Collenchyma.**—This form of tissue is characterized by its cells being prismatic, more elongated than ordinary parenchyma, and thickened in their angles with a colloidal substance. The cells, like those of parenchyma tissue contain protoplasm and a nucleus, and frequently chloroplasts (Fig. 40). Collenchyma is generally found underneath the epidermis, and gives strength to that tissue. It is frequently observed forming the "ribs" of stems and fruits of the *Umbelliferae* and "ribs" of stems of the *Labiatae*. In many leaves it has been found as the supporting and strengthening tissue between the stronger veins and the epidermis.

**Sclerenchyma** or stony tissue comprises a variety of supporting elements having thickened cell walls composed of lignocellulose. When first formed these cells resemble those of ordinary parenchyma in having walls of pure cellulose, but later *lignin* becomes deposited on the inner surface of the walls in one or more layers. (Occasionally as in the rhizomes of Ginger no lignin is deposited on the walls of the sclerenchyma fibers). When sclerenchyma is composed of cells which are more or less isodiametric or moderately elongated, with thickened lignified walls and conspicuous pores, its elements are called **Stone Cells**. Stone cells are distributed in fruits, seeds and barks of many plants, rarely in woods. They have been found forming the gritty particles in the "flesh" of certain fruits as the Pear, the endocarp or stone region of drupaceous fruits as the Olive, Peach, Cubeb, Pepper, etc., the hard portions of seed coats as in *Physostigma*, Walnuts, etc. Each stone cell presents for examination a cell wall of cellulose with one or several layers of lignin on its inner surface which surround a *central lumen*. The latter is in communication with radial *pore canals* leading outward to the middle lamella. Longitudinal pore canals are also evident.

When sclerenchyma is composed of cells which are greatly elon-

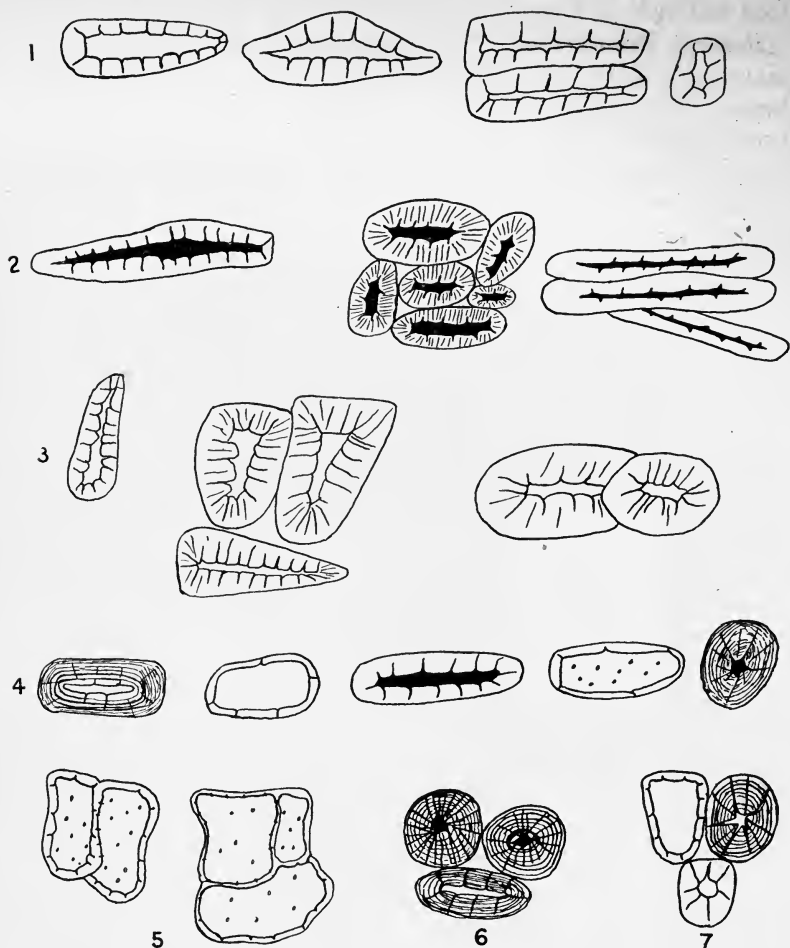

FIG. 42.—Stone cells from various sources. 1, From olive pit; 2, from coconut endocarp; 3, from flesh of pear; 4, from aconite root; 5, from capsicum; 6, from hazelnut; 7, from allspice. (Drawing by Hoffstein.)

gated and more or less obtusely or taper ended, its component elements are termed **Scierenchyma fibers**. These fibers are frequently spindle-shaped, contain air and exhibit oblique slits in their walls. They are either polygonal, rectangular or somewhat rounded in

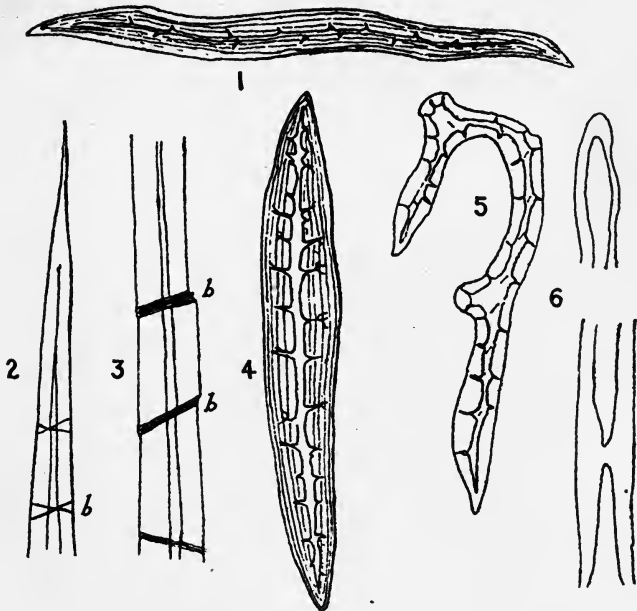

FIG. 43.—Sclerenchyma fibers from different sources. 1, From powdered cinnamon bark; 2, End of bast fiber of flax stem showing transverse markings (*b*); 3, middle portion of flax fiber showing characteristic cross markings at *b*; 4, bast fiber from cinchona bark; 5, branched bast fiber from choke cherry bark; 6, above, end, and below, median portion of bast fiber of jute. All highly magnified.

transverse section. They occur in various parts of roots, stems, leaves, fruits and seeds as supporting elements. When sclerenchyma fibers occur in the xylem region of fibro-vascular bundles they are termed *Wood Fibers*; when they appear in the phloem region, *Bast Fibers*.

## EPIDERMIS

**Epidermis** is the outer covering tissue of a plant and is protective in function. Its cells may be brick-shaped, polygonal, equilateral or wavy in outline. Their outer walls are frequently cutinized (infiltrated with a waxy-like substance called cutin). Among the epidermal cells of leaves and young green stems may be found numerous pores or *stomata* (sing. stoma) surrounded by pairs of crescent-

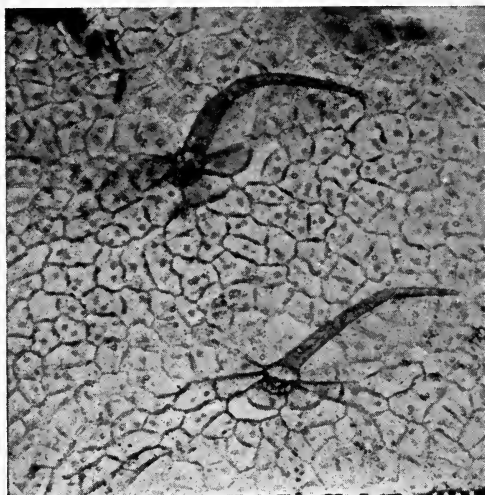

FIG. 44.—Upper epidermis of *Comptonia asplenifolia* leaf (surface view) showing epidermal cells and two non-glandular trichomes.

shaped cells, called guard cells. The stomata are in direct communication with air chambers beneath them which in turn are in communication with intercellular spaces of the tissue beneath. The function of the stomata is to give off watery vapor and take in or give off carbon dioxide, water and oxygen. In addition to stomata some leaves possess groups of *water stomata* which differ from *transpiration stomata* in that they always remain open, are circular in outline, give off water in droplets directly, and lie over a quantity of small-celled glandular material which is in connection with one or more fibro-vascular bundles. Examples: Leaves of *Crassula*, *Saxifraga* and *Ficus*.



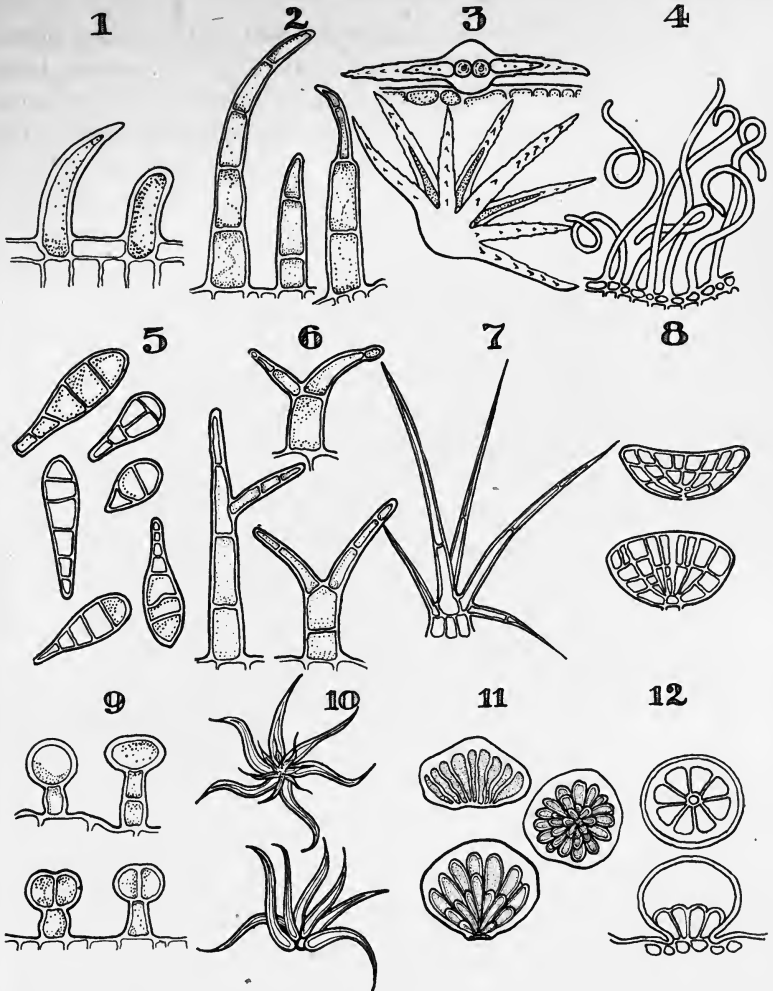

FIG. 45.—Trichomes from different sources. 1, Unicellular non-glandular trichomes as seen growing out of epidermal cells of *Senna*; 2, uniseriate non-glandular trichomes of *Digitalis*; 3, unicellular stellate trichomes from *Deutzia scabra*; 4, unicellular twisted trichomes from lower epidermis of *Eriodictyon*; 5, clavate non-glandular trichomes from scraping of epidermis of the fruits of *Rhus glabra*; 6, 2-branched trichomes of *Hyoscyamus muticus*, a substitute for Henbane; 7, branched multicellular trichome of *Marrubium*; 8, glandular trichomes from strobile of *Humulus* (Lupulin); 9, glandular trichomes from leaves of *Digitalis purpurea*; 10, aggregate, non-glandular trichomes of *Kamala*; 11, lateral view (to left) and vertical view (to right) of glandular trichomes of *Kamala*; 12, vertical view (above) and profile view (below) of 8-celled glandular hair from *Mentha piperita*. All highly magnified.

The epidermis of leaves, stems, fruits, and seeds of many plants frequently give rise to outgrowths in the form of papillæ, hairs and scales. *Epidermal papillæ* are short protuberances of epidermal cells. They may be seen to advantage on the upper epidermis of the

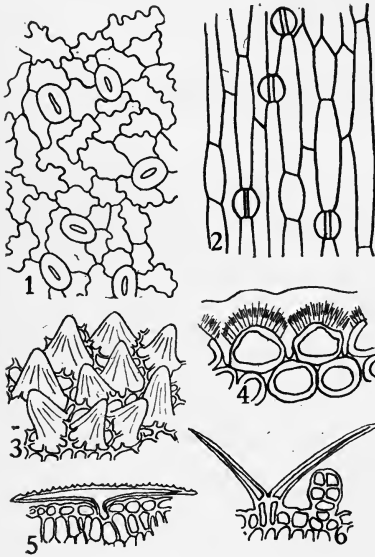

FIG. 46.

FIG. 46.—1, Epidermis of oak leaf; 2, epidermis of Iris leaf, both viewed from the surface; 3, group of cells from petal of *Viola tricolor*; 4, two epidermal cells in cross-section showing thickened outer wall differentiated into three layers, namely, an outer cuticle, cutinized layer (shaded), and an inner cellulose layer; 5 and 6, epidermal outgrowths in the form of scales and hairs. (1, 2, 6 after Stevens, 3 after Strasburger, 4 after Sachs, and 5 after de Bary.)

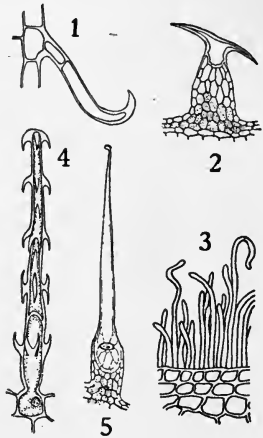

FIG. 47.

FIG. 47.—Different forms of epidermal outgrowths. 1, Hooked hair from *Phaseolus multiflorus*; 2, climbing hair from stem of *Humulus Lupulus*; 3, rod-like wax coating from the stem of *Saccharum officinarum*; 4, climbing hair of *Loasa hispida*; 5, stinging hair of *Urtica urens*. (Fig. 3 after de Bary; the remainder from Haberlandt.)

ligulate corolla of various species of *Chrysanthemum*, on the lower epidermis of the foliage leaves of species of *Erythroxylon* and upon the upper epidermis of the petals of the Pansy (*Viola tricolor*). **Epidermal hairs** or **trichomes** are more elongated outgrowths of one or more epidermal cells. They may be unicellular (Cotton) or

multicellular, non-glandular (simple) or glandular. The *non-glandular* hairs may be of various shapes, viz.: clavate (club-shaped) as on *Rhus glabra* fruits; stellate (or star-shaped) as on *Deutzia* leaves; candelabra-shaped, as on Mullein leaves; filiform as on *Hyoscyamus*, *Belladonna* and *Digitalis* leaves; hooked, as on stems of *Phaseolus multiflorus* or Hops; barbed, as on the stems of *Loasa* species; or tufted, as found on the leaves of *Marrubium vulgare*. They may be simple as in Cotton, etc., or branched as in *Hyoscyamus muticus*.

The *glandular hairs* comprise those whose terminal cell or cells are modified into a more or less globular gland for gummy, resinous or oily deposits. They are generally composed of a stalk and a head region although rarely the stalk may be absent. The stalk may be unicellular, bicellular or uniseriate (consisting of a series of superimposed cells). The head varies from a one- to many-celled structure. The drug *Lupulin* consists of the glandular hairs separated from the strobiles of *Humulus lupulus*.

**Scales** are flat outgrowths of the epidermis composed of one or several layers of cells. They occur attached to the stipes of *Aspidium*, *Osmunda* and other ferns, where they are called "chaff scales." They are also found on a number of higher plants.

Plant hairs are adapted to many different purposes. They may absorb nourishment in the form of moisture and mineral matter in solution, e.g., root hairs. Those which serve as a protection to the plant may be barbed and silicified, rendering them unfit for animal food, or, as in the nettle, charged with an irritating fluid, penetrating the skin when touched, injecting the poison into the wound. A dense covering of hairs also prevents the ravages of insects and the clogging of the stomata by an accumulation of dust. They fill an important office in the dispersion of seeds and fruits, as with their aid such seeds as those of the milkweed and *Apocynum* are readily scattered by the wind.

The reproductive organs of many Cryptogams are modified hairs, as the sporangia of Ferns.

#### ENDODERMIS

**Endodermis** is the "starch sheath" layer of cells, constituting the innermost layer of the cortex. In Angiospermous stems it

usually resembles the other parenchyma layers of cortex as to structural characteristics, save that it frequently contains more starch. In fern stems, roots of Monocotyledons and of Dicotyledons of primary growth, however, its cells are clearly distinguished from the other cells of the primary cortex by their elongated form and suberized (occasionally lignified) radial walls. In the roots of Mexican Sarsaparilla the inner as well as the radial walls are suberized; in those of the Hcnduras variety, inner, radial and outer walls all show suberization. Endodermal tissue is devoid of intercellular-air-spaces. Its cells contain protoplasm and nucleus. Its functions seem to be to give protection to the stele (tissues within it) and to reduce permeability between primary cortex and stele.

### CORK

**Cork** or suberous tissue is composed of cells of tabular shape, whose walls possess suberized layers. Its cells are mostly filled with air containing a yellow or brownish substance. It is derived from the phellogen or cork cambium which cuts off cork cells outwardly. Cork tissue is devoid of intercellular-air-spaces. It forms a protective covering to the roots of secondary growth, stems (after the first season) of Dicotyledons and Gymnosperms, and wounds of stems and branches. Living cork cells contain protoplasm and cell sap while dead cork cells are filled with air.

The walls of cork cells resist the action of concentrated sulphuric acid. They are colored green, when in contact with alcoholic extract of chlorophyll for several days in the dark.

### LATICIFEROUS TISSUE

This form of tissue comprises either *latex cells*, *laticiferous vessels*, or *secretory cells* differing from each other in origin and method of development. **Latex cells** are elongated tubes which take their origin from meristematic cells of the embryo. Elongating with the growth of the plant, they branch in various directions and traverse at maturity all of its organs. Such cells are abundant in the following families: *Apcoynaceæ*, *Asclepiadaceæ*, *Urticaceæ* and *Euphorbiaceæ*.

**Laticiferous vessels** are long simple or branching tubes, which owe their origin to chains of superimposed cells whose transverse walls

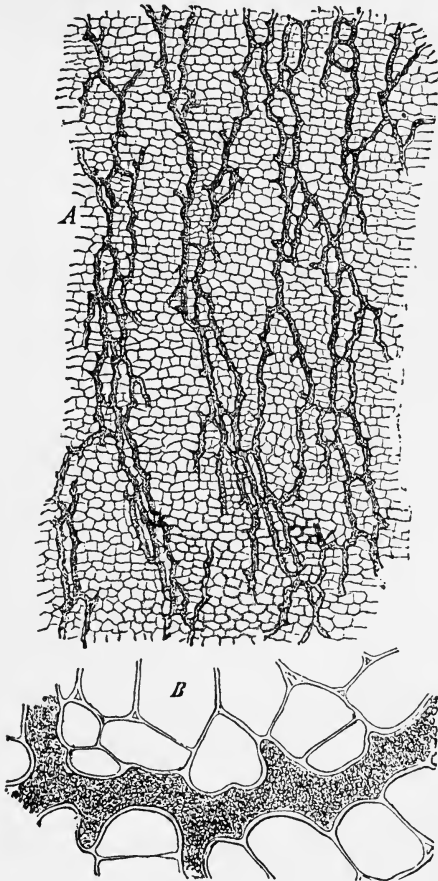

FIG. 48.—Laticiferous vessels from the cortex of root of *Scorozonora hispanica*. A, As seen under low power, and B, a smaller portion under high power. (Stevens, after Sachs.)

have early become absorbed, the lumina of the cells then becoming filled with latex. They are found in various parts of roots, stems, and leaves. When branched the branches connect with those of

other tubes forming anastomosing network. These vessels occur in the following families: *Compositæ*, *Papaveraceæ*, *Campānulaceæ*, *Convolvulaceæ*, *Euphorbiaceæ*, *Araceæ*, *Oleaceæ*, *Geraniaceæ*, and *Musaceæ*.

Secretory cells with a latex-like content are probably of secondary origin in plants. They resemble in many respects latex cells and are seen in various species of the *Celastraceæ*, *Urticaceæ*, *Tiliaceæ*, and *Oleaceæ* families.

All laticiferous elements contain a colorless, milky-white, or otherwise colored emulsion of gum-resins, fat, wax, coatchouc and in some cases, alkaloids, tannins, salts, ferments, etc. This emulsion is called "*latex*."

#### SIEVE (LEPTOME OR CRIBIFORM) TISSUE

This tissue found in the phloem (rarely in the xylem) region of fibro-vascular bundles consists of superimposed, elongated, tubular cells whose longitudinal walls are thin and composed of cellulose and whose transverse walls, called "*sieve plates*," are perforated, permitting of the passage of proteids from one cell to another. Occasionally sieve plates are formed on the longitudinal walls. Sieve tubes are usually accompanied by companion cells excepting in Pteridophytes and Gymnosperms. Both companion cells and sieve tubes arise by the division of the same mother-cell. The companion cells may be distinguished from the sieve tubes by their abundant protoplasmic contents, and also by the fact that they retain their nuclei after complete maturation. Besides sieve tubes, companion cells, and bast fibers, parenchyma cells are often found in the phloem.

#### TRACHEARY TISSUE

The tracheary tissue of plants comprises two kinds of elements, the *tracheæ* (ducts or vessels) and *tracheids*. Both of these conduct *crude sap* (water with mineral salts in solution). The *tracheæ* are very long tubes of a cylindrical or prismatic shape which are formed by the disintegration of the transverse walls between certain groups of superimposed cells, during the growth of the plant. The tubes frequently retain some of their transverse walls. The longitudinal

walls of these tubes are of varying thickness, usually, however, thinner than those of woody fibers. The thickness is due to an infil-

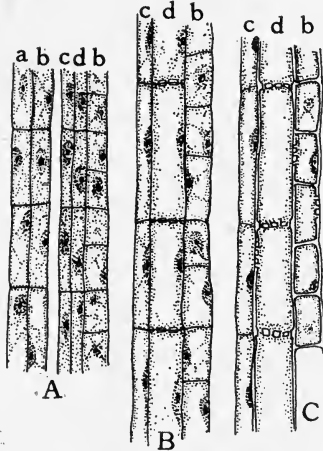

FIG. 49.

FIG. 49.—Stages in the development of sieve tubes, companion cells, and phloem parenchyma. A, a and b, Two rows of pterome cells; in c and d, a has divided longitudinally and c is to become companion cells; d, a sieve tube, and b, phloem parenchyma. B, c, Companion cells, and d, a beginning sieve tube from c and d, respectively in A. The cross-walls in d are pitted; b, phloem parenchyma grown larger than in A. C, The same as B with the pits in the cross-walls of the sieve tubes become perforations, and the nuclei gone from the cells composing the tube. (From Stevens.)

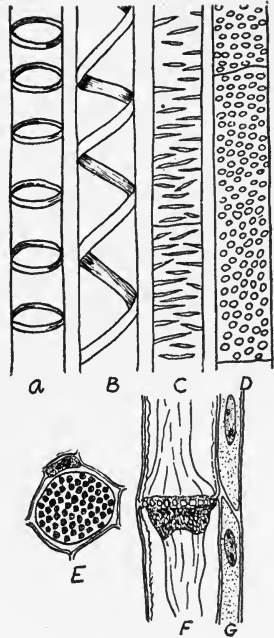

FIG. 50.

FIG. 50.—Vascular elements. A, annular tracheal tube; B, spiral trachea; C, reticulated tracheal tube; D, pitted tracheal tube; E, cross-section through plate of sieve tube, and adjoining companion cell; F, length-wise section of sieve tube; G, portions of two companion cells. (A, B, C, D, Robbins; E, F, and G, after Strasburger.)

tration of lignin upon the original cellulose wall. The walls show characteristic thickenings on their inner surfaces.

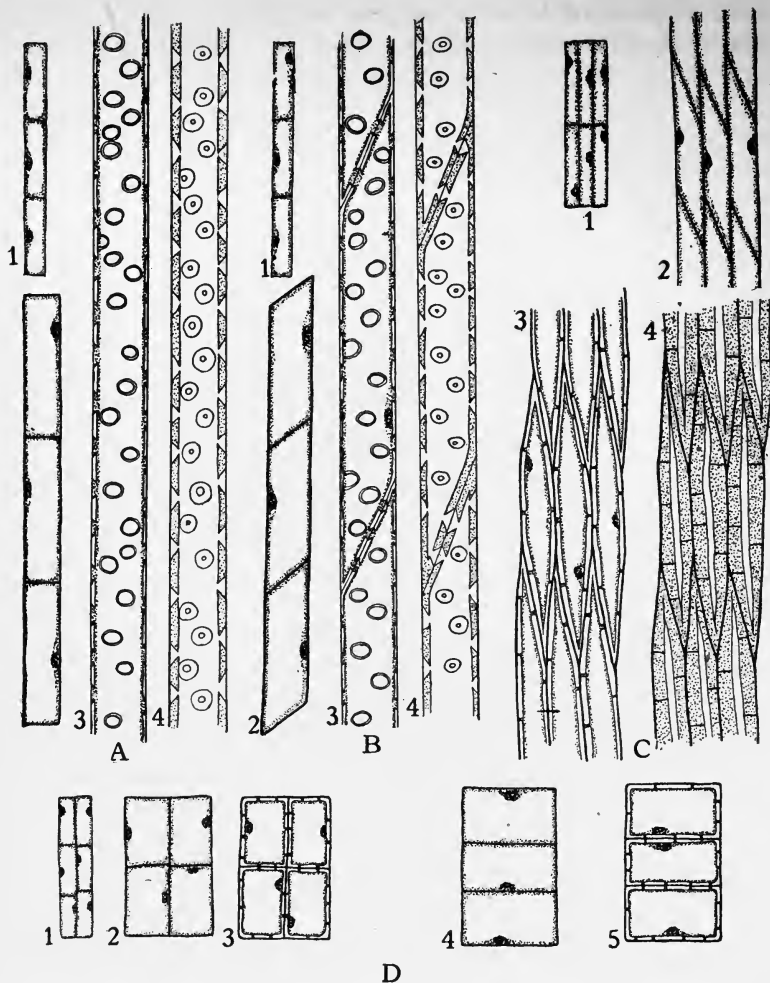

FIG. 51.—Stages in the development of the elements of the xylem. *A*, progressive steps in the development of a tracheal tube. 1, Row of plerome or cambial cells that are to take part in the formation of a tube; 2, the same at a later stage enlarged in all dimensions; 3, the cells in 2 have grown larger, their cross-walls have been dissolved out, and the wall has become thickened and pitted; 4, the walls in 3 have become more thickened, the pits have an overhanging border, the walls have become lignified as indicated by the stippling, and finally the protoplasts have disappeared, and the tube is mature and dead. *B*, Stages in the formation of tracheids from plerome or cambial cells. The steps



**Tracheæ** are classified according to their markings as follows:  
*Annular*, with ring-like thickenings.  
*Spiral*, with spiral thickenings.  
*Reticulate*, with reticulate thickenings.

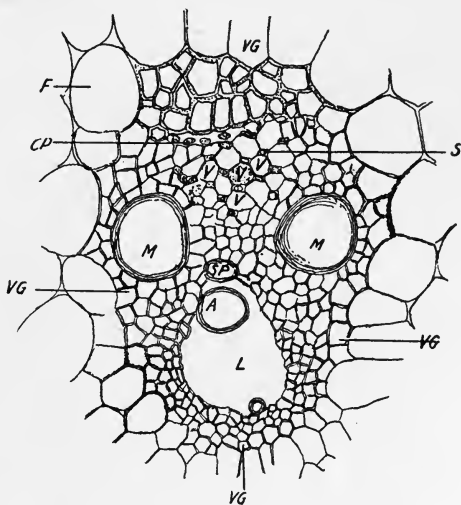

FIG. 52.—Closed collateral bundle of stem of *Zea mays*. VG, Bundle sheath; L, intercellular space; A, ring from an annular tracheal tube; SP, spiral tracheal tube; M, pitted vessels; V, sieve tubes; S, companion cells; CP, crushed primary sieve tubes; F, thin-walled parenchyma of the ground or fundamental tissue. (From Sayre after Strasburger.)

*Porous* or *pitted* with spherical or oblique slit pores.  
*Annulo-spiral*, with both ring and spiral thickenings.  
*Scalariform*, with ladder-like thickenings.

are the same as in A, excepting that the cross-walls remain and become pitted. C, steps in the development of wood fibers from cambial cells. 1, Cambial cells; 2, the same growth larger in all dimensions with cells shoving past each other as they elongate; 3, a later stage with cells longer and more pointed and walls becoming thickened and pitted; 4, complete wood fibers with walls more thickened than in the previous stage and lignified, as shown by the stippling. The protoplasts in this last stage have disappeared and the fibers are dead. D, steps in the formation of wood parenchyma from cambial or procambial cells. 1, Group of cambial or plerome cells; 2, the same enlarged in all dimensions; 3, the same with walls thickened and pitted; 4 and 5 show the same stages as 2 and 3, but here the cells have enlarged radially or tangentially more than they have vertically. The walls of these cells are apt to become lignified, but the cells are longer lived than the wood fibers. (From Stevens.)

**Tracheids** are undeveloped ducts having *bordered pores* and frequently scalariform thickenings. Like tracheæ their walls give the characteristic lignin reaction with phloroglucin and HCl. The bordered pores of coniferous tracheids (Fig. 77) exhibit a wall surrounding the pore which forms a dome shaped protrusion into the cell. Like tracheæ, also, tracheids convey water with mineral salts in solution. Tracheids and medullary rays make up most of the wood of Conifers.

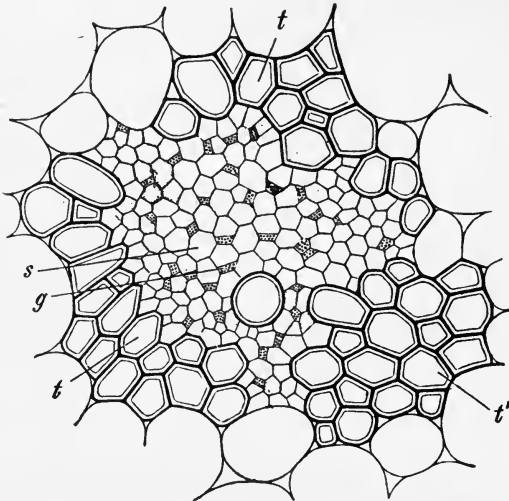

FIG. 53.—Transverse section of a concentric bundle from the rhizome of *Iris* (a monocotyledon). Xylem surrounding the phloem. *t*, Tracheæ; *t'*, protoxylem; *s*, sieve-tubes; *g*, companion cells of the internal phloem portion. (From Sayre after Vines.)

### MEDULLARY RAYS

These are bands of parenchyma cells which extend radially from the cortex to the pith (primary medullary rays) or from a part of the xylem to a part of the phloem (secondary medullary rays). In tangential-longitudinal sections they usually appear spindle shaped while in radial-longitudinal sections they are seen crossing the other elements. Their primary function is to supply the cambium and wood with elaborated sap formed in the leaves and conveyed away by the sieve tubes, and phloem parenchyma and to supply the cam-

bium and phloem with crude sap which passes up mainly through the tracheæ and tracheids from the absorptive regions of the roots. They furthermore serve as storage places for starch, alkaloids, resins, and other substances.

**Fibro-vascular Bundles** are groups of fibers, vessels and cells coursing through the various organs of a plant and serving for conduction

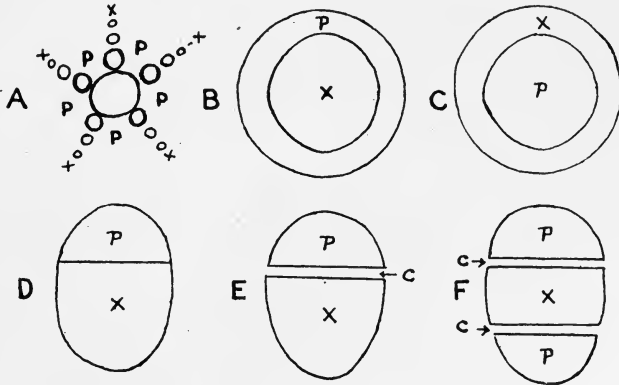

FIG. 54.—Diagrams illustrating the arrangement of the regions in different types of fibrovascular bundles. In each diagram x represents xylem; P, phloem and C, cambium. A, Radial bundle; B, concentric bundle of fern stem type; C, concentric bundle of monocotyl type; D, closed collateral bundle; E, open collateral bundle; F, bi-collateral bundle.

and support. According to the relative structural arrangement of their xylem and phloem masses they may be classed as follows:

I. *Closed collateral*, consisting of a mass of xylem lying alongside of a mass of phloem, the xylem facing toward the center, the phloem facing toward the exterior. Stems of most Monocotyledons and Horsetails.

II. *Open collateral*, consisting of a mass of xylem facing toward the pith and a mass of phloem facing toward the exterior and separated from each other by a cambium. Stems and leaves of Dicotyledons and roots of Dicotyls and Gymnosperms of secondary growth.

III. *Bicollateral*, characterized by a xylem mass being between an inner and an outer phloem mass. There are two layers of cambium cells, one between the xylem and inner phloem mass, the other

between the xylem and outer phloem mass. Seen chiefly in stems and leaves of the *Cucurbitaceæ* and *Solanaceæ*.

IV. *Concentric*, characterized by a central xylem mass surrounded by a phloem mass or *vice versa*. No cambium present.

(a) *Concentric*, with xylem central in bundle. Seen in stems and leaves of nearly all ferns and the *Lycopodiaceæ*.

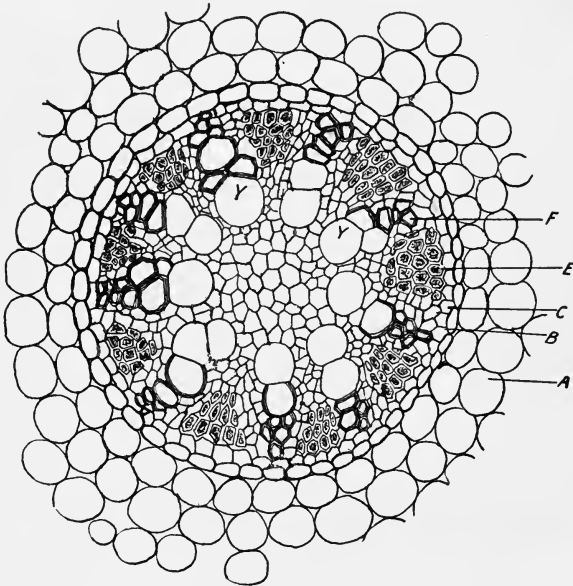

FIG. 55.—Cross-section through a portion of a root of *Acorus calamus*. A. Cortical parenchyma; B, endodermis; C, pericycle; E, phloem; F, xylem. At Y, Y, are large tracheal tubes, which were formed last, the narrow tubes near the periphery of the xylem being formed first. At the center of the root, within the circle of the radial vascular bundle, occur thin-walled parenchymatous pith cells. (From Sayre after Frank.)

(b) *Concentric*, with phloem central in bundle. Seen in stems and leaves of some *Monocotyledons*. Examples: Calamus and Convalaria rhizomes.

V. *Radial*, characterized by a number of xylem and phloem masses alternating with one another. Seen in the roots of all *Spermatophytes* and *Pteridophytes*.

*Xylem* is that part of a fibro-vascular bundle that contains wood cells and fibers. It may also contain tracheæ, tracheids, seldom sieve tubes.

*Phloem* is that part of a fibro-vascular bundle that contains sieve tubes, phloem cells, and often bast fibers.

#### SECRETION SACS (SECRETION CELLS)

These were formerly parenchyma cells which sooner or later lost their protoplasm and nucleus and became receptacles for oil, resin, oleoresin, mucilage or some other secretory substance. They are generally found in parenchyma regions of stems, roots, leaves, flower or fruit parts and frequently possess suberized walls. Good illustrations of these structures may be seen in Ginger and Calamus.

#### INTERCELLULAR AIR SPACES

Intercellular air spaces are cavities filled with air found between cells or groups of cells throughout the bodies of higher plants. Their function is to permit of the rapid movement of atmospheric gases through the entire plant body. They are formed either by the breaking down of the middle lamella of the cell walls, where several cells come together, and a later separation of the cells at these places (*Schizogenous intercellular-air-spaces*), or by a breaking down and disappearance of cell walls common to groups of cells (*lysigenous intercellular-air-spaces*). In terrestrial plants which live in middle regions (*mesophytes*) and in desert plants (*xerophytes*) the intercellular-air-spaces are averagely small and more or less angular. In plants of swamp or marsh habit they are medium-sized, while in those which live entirely in the water (*hydrophytes*) they are of large size and more or less rounded.

#### SECRETION RESERVOIRS

These structures are either found as globular or irregular spaces, as in Orange and Lemon Peel and Eucalyptus leaves, containing oil or oil and resin when they are called *internal glands*, or, as tube-like spaces filled with hydrocarbon principles such as are found in Pine leaves and stems, when they sometimes receive the name of *secretion*

*canals*. Occasionally they are named according to the nature of their contents—resin or oil canal or reservoir, etc. They are generally lined with a layer of cells, usually more or less flattened, which are characterized by possessing large nuclei. To this layer has been assigned the name “epithelium.”

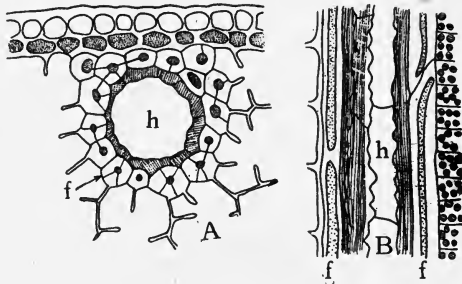

FIG. 56.—Resin duct (secretion reservoir) in leaf of *Pinus silvestris*, in cross section at A, and in longitudinal section at B; h, cavity surrounded by the secreting cells; f, f, sclerenchyma fibers surrounding and protecting the duct. (Stevens, after Haberlandt.)

**Classification of Tissues According to Function.**—According to their particular function, tissues may be classified as follows:

|                         |   |   |
|-------------------------|---|---|
| I. CONDUCTING TISSUES   | { | Parenchyma (fundamental tissue)<br>Medullary rays<br>Xylem cells (wood parenchyma)<br>Tracheæ (ducts)<br>Phloem cells<br>Sieve tubes<br>Companion cells |
| II. PROTECTIVE TISSUES  | { | Epidermis (outer cell walls cutinized)<br>Cork (suberized tissue)   |
| III. MECHANICAL TISSUES | { | Bast fibers<br>Wood fibers<br>Sclerenchyma fibers<br>Stone cells<br>Collenchyma   |

## CHAPTER VII

### PLANT ORGANS AND ORGANISMS

An *organ* is a part of an organism made up of several tissues and capable of performing some special work.

An *organism* is a living entity composed of different organs or parts with functions which are separate, but mutually dependent, and essential to the life of the individual.

The organs of flowering plants are either **Vegetative** or **Reproductive**. The vegetative organs of higher plants, are *roots*, *stems*, and *leaves*. They are concerned in the absorption and elaboration of food materials either for tissue-building or storage.

The reproductive organs of higher plants include those structures whose function it is to continue the species, viz.: the *flower*, *fruit* and *seed*.

The ripened seed is the product of reproductive processes, and the starting point in the life of all Spermatophytes. The living part of the seed is the *embryo*, which, when developed, consists of four parts, the *caulicle*, or rudimentary stem, the lower end of which is the beginning of the root, or *radicle*. At the upper extremity of the stem are one, two, or several thickened bodies, closely resembling leaves, known as *cotyledons*, and between these a small bud or *plumule*.

The function of the cotyledon is to build up nourishment for the rudimentary plantlet until it develops true leaves of its own.

### THE ROOT

The root is that part of the plant that grows into or toward the soil, that never develops leaves, rather rarely produces buds, and whose growing apex is covered by a cap.

The functions of a root are absorption, storage and support. Its principal function is the absorption of nutriment and to this end it generally has branches of rootlets covered with root-hairs which largely increase the absorbing surface. These root-hairs are of

minute and simple structure, being merely elongations of the epidermis of the root back of the root cap into slender tubes with thin walls.

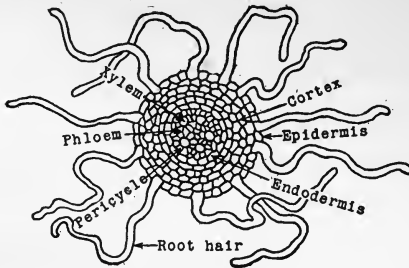

FIG. 57.—Cross-section of rootlet in the region of the root-hairs. (From Stevens.)

The tip of each rootlet is protected by a sheath- or scale-like covering known as the *root cap*, which not only protects the delicate growing point, but serves as a mechanical aid in pushing its way through

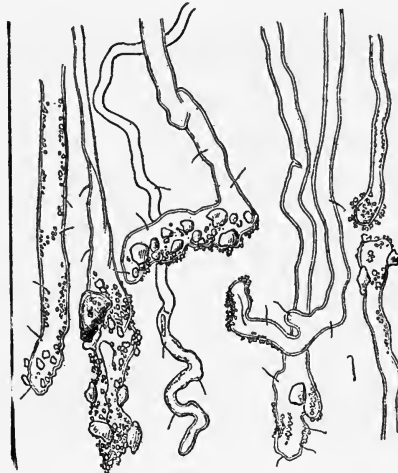

FIG. 58.—Root-hairs, with soil-particles adhering. (Gager, after Sachs.)

the soil. The generative tissues in the region of the root cap are: *plerome*, producing fibro-vascular tissue; *periblem*, producing cortex; *dermatogen*, producing epidermis; and *calyptrogen*, producing the root cap.



## DIFFERENCES BETWEEN ROOT AND STEM

*The Root*

1. Descending axis of plant.
2. Growing point sub-apical.
3. Contains no chlorophyll.
4. Branches arranged irregularly.
5. Does not bear leaves or leaf rudiments.
6. Structure comparatively simple.

*The Stem*

1. Ascending axis of plant.
2. Growing point apical.
3. Chlorophyll sometimes present.
4. Branches with mathematical regularity.
5. Bears leaves and modifications.
6. Structure better defined.

**Classification of Roots as to Form.**—1. *Primary or first root*, a direct downward growth from the seed, which, if greatly in excess of the lateral roots, is called the *main* or *tap root*. Examples: *Taraxacum*, Radish.

2. *Secondary roots* are produced by the later growths of the stem, such as are covered with soil and supplied with moisture. Both primary and secondary roots may be either fibrous or fleshy.

The grasses are good examples of plants having fibrous roots. Fleshy roots may be multiple, as those of the *Dahlia*, or may assume simple forms, as follows:

*Fusiform*, or *spindle-shaped*, like that of the radish or parsnip.

*Napiform*, or *turnip-shaped*, somewhat globular and becoming abruptly slender then terminating in a conical tap root, as the roots of the turnip.

*Conical*, having the largest diameter at the base then tapering, as in the Maple.

3. *Anomalous roots* are of irregular or unusual habits, subserving other purposes than the normal.

4. *Adventitious roots* are such as occur in abnormal places on the plant. Examples: Roots developing on *Bryophyllum* and *Begonia* leaves when placed in moist sand.

5. *Epiphytic roots*, the roots of epiphytes, common to tropical forests, for example, never reach the soil at all, but cling to the bark of trees and absorb nutriment from the air. Example: Roots of *Vanilla*.

6. The roots of parasitic plants are known as *Haustoria*. These penetrate the bark of plants upon which they find lodgement, known

as hosts, and absorb nutritious juices from them. The *Mistletoe*, *Dodder* and *Gerardia* are typical parasites.

**Duration of Root.**—Plants are classified according to the duration of the root, as follows:

1. *Annual plants* are *herbs* with roots containing no nourishment for future use. They complete their growth, producing flower, fruit and seed in a single season, then die.

2. *Biennial plants* develop but one set of aerial organs the first year, e.g., the leaves, and, as in the beet and turnip, etc., a large amount of reserve food material is stored in the root for the support of the plant the following season when it flowers, fruits and dies.

3. *Perennial plants* live indefinitely, as trees.

**Root Histology.—Monocotyledons.**—The histology of monocotyledonous roots varies, depending upon relations to their surroundings, which may be aquatic, semi-aquatic, mesophytic; or xerophytic. In this connection we will discuss only the type of greatest pharmacognic importance, i.e., the mesophytic type as seen in its most typical form in the transverse section of Honduras Sarsaparilla root.

Examining such a section from periphery toward the center, one notes the following:

1. *Epidermis* of a single layer of cells many of which give rise to root-hairs.

2. *Hypodermis* of two or three layers of cells whose walls are extremely thickened.

3. *Cortex*, consisting of a broad zone of parenchyma cells many of which contain starch grains.

4. *Endodermis* of one layer of endodermal cells whose walls are extremely thickened through the infiltration of suberin and lignin.

5. *Pericambium* of one or two layers of meristematic cells whose walls are extremely thin.

6. A *radial fibro-vascular* bundle of many alternating xylem and phloem patches and hence *polyarch*. The phloem tissue consists of phloem cells and sieve tubes. The xylem is composed of xylem cells, tracheæ and wood fibers.

7. *Medulla* or *pith* composed of parenchyma cells containing starch and often showing xylem patches cut off and enclosed within it.

**Dicotyledons.**—The typical dicotyl root is a tetrarch one, four xylem alternating with four phloem patches. These roots have an unlimited power of growth.

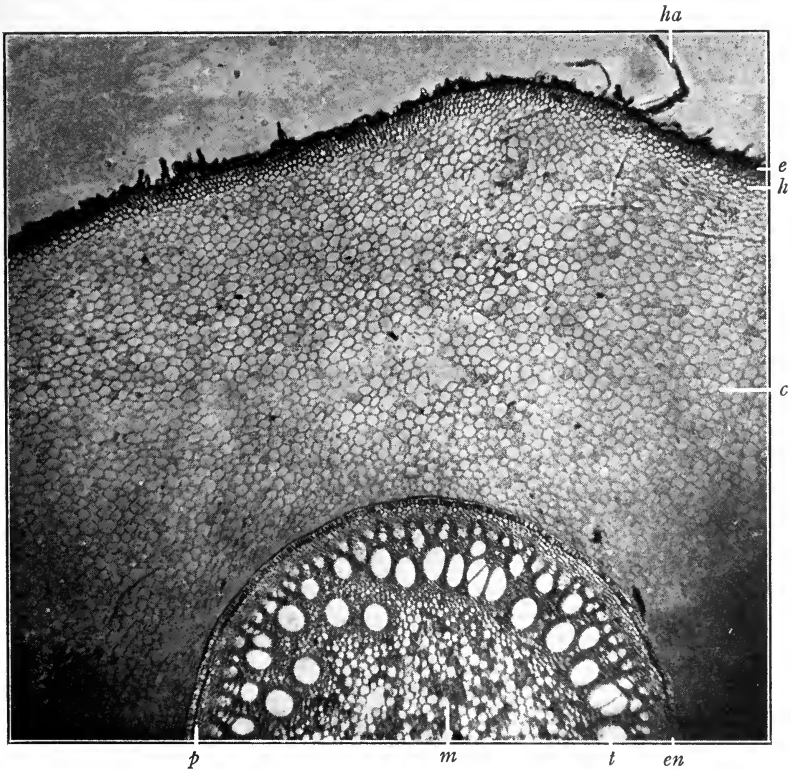

FIG. 59.—Part of a transverse section of Honduras sarsaparilla root showing epidermis (*e*), root hair (*ha*), hypodermis (*h*), cortex (*c*), endodermis (*en*), pericambium (*p*), trachea of one of the numerous xylem patches (*t*), and pith (*m*). The phloem patches are the small oval cellular areas wedged in between the outer portions of adjacent xylem masses. (Photomicrograph.)

#### A. Of Primary Growth.

A transverse section of a dicotyl root in its young growth shows the following structure from periphery toward center:

1. Epidermis with cutinized outer walls, the cells often elongating to form root-hairs.

2. Hypodermis.
3. Primary cortex with usually small intercellular spaces.
4. Endodermis, or innermost layer of cells of the cortex with lenticularly thickened radial walls.

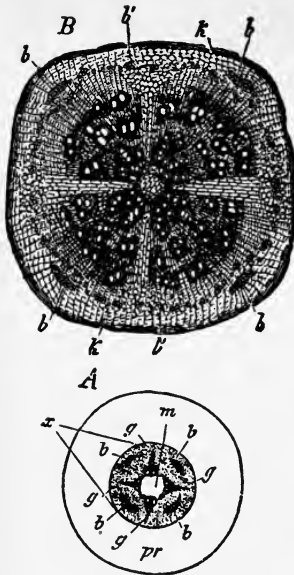

FIG. 60.—Cross-section of a young root of *Phaseolus multiflorus*. A, *pr*, cortex; *m*, pith; *x*, stele or central cylinder—all tissue within the pericycle, inclusive; *g*, primary xylem bundles; *b*, primary phloem bundles. B, cross-section of older portion of root; lettered as in A; *b'*, secondary phloem, *k*, cork. (Stevens, after Vines.)

5. Pericambium of one to two layers of actively growing cells which may produce side rootlets.

6. Radial fibro-vascular bundle of four, rarely two or three or five or six phloem patches alternating with as many xylem arms. Not uncommon to find bast or phloem fiber along outer face of each phloem patch. Xylem has spiral tracheæ, internal to these a few pitted vessels, then, as root ages, more pitted vessels, also xylem cells and wood fibers make their appearance.

7. Pith, a small zone of parenchyma cells.

B. *Of Secondary Growth* (Most official roots).

At about six weeks one notes cells dividing by tangential walls in the inner curve of phloem patches. This is intrafascicular cambium. A single layer of flattened cells starts to cut off on its inner side a quantity of secondary xylem and pushes out the patches of bast fibers, adds a little secondary phloem on the outer side. Secondary xylem finally fills up the patches between the arms. The patches of bast fibers get flattened out. The pericambium has a tendency to start division into an inner and outer layer. The outer layer becomes a cork cambium (phellogen) surrounding the bundle inside of the endodermis. It cuts off cork tissue on its outer face, hence all liquid material is prevented from filtering through and cortex including endodermis, as well as the

epidermis, shrivel and dry up and separate off at the age of two to three months. The cork cambium (phellogen) may lay down secondary cortex internal to itself and external to the phloem.

Patches of cells of the *inner layer* of *pericambium* divide rapidly and are called interfascicular cambium. These join the intrafascicular cambium to form a continuous cambium ring which then cuts off additional secondary xylem on its inner face and secondary phloem on its outer face pushing inward the first-formed or protoxylem and outward the first-formed or protophloem. The medullary rays become deepened.

Thus, in a transverse section made through a portion of a Dicotyl root showing *secondary growth*, the following regions are noted passing from periphery to center:

- |                        |                             |
|------------------------|-----------------------------|
|                        | 1. Cork                     |
|                        | 2. Cork cambium (phellogen) |
|                        | 3. Secondary cortex         |
| Fibro-vascular tissue. | 4. Protophloem              |
|                        | 5. Secondary phloem         |
|                        | 6. Cambium                  |
|                        | 7. Secondary xylem          |
|                        | 8. Protoxylem               |

Strands of cells extending radially from the cortex to the center of the section separating each open fibro-vascular bundle from its neighbors. These are called medullary rays.

#### **Histology and Development of a Dicotyl Root (California Privet)**

—A. Make a permanent mount of a T. S. of the root of the California Privet (*Ligustrum Californicum*) cut just above the root cap, and note the following structures, passing from periphery toward the center (see Fig. 61):

1. Epidermis, composed of a layer of epidermal cells whose outer walls have been infiltrated with a substance called *Cutin*.
2. Hypodermis, a layer of somewhat thick walled cells just beneath the epidermis.
3. Cortex, composed of cortical parenchyme cells with small angular intercellular air spaces.

4. Endodermis, or innermost layer of cells of the cortex, whose radial walls are lenticularly thickened.

5. Pericambium, of a layer of actively growing meristematic cells, which has the power of producing lateral rootlets.

6. Radial fibro-vascular bundle of five xylem arms alternating with as many phloem patches. Note the narrow spiral tracheæ in the xylem patches.

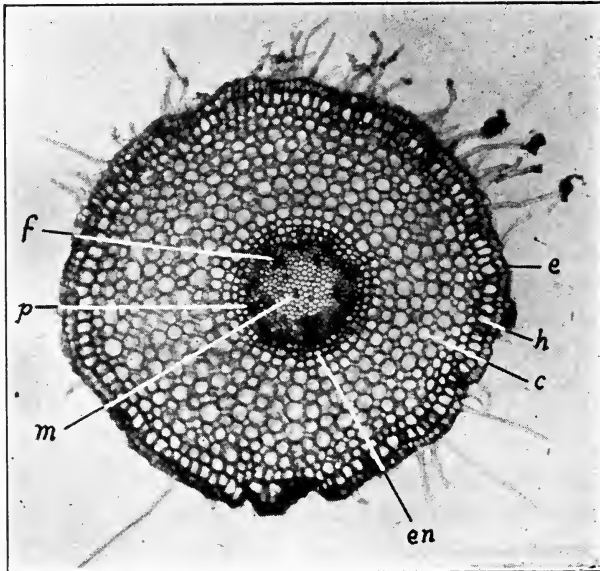

FIG. 61.—Photomicrograph of a transverse section of a California Privet root of primary growth showing epidermis (*e*); hypodermis (*h*); cortex (*c*); endodermis (*en*); pericambium (*p*); a xylem arm of the radial bundle (*f*) and pith (*m*).

The section you have just studied illustrated in general the appearance of any Dicotyl root of primary growth.

B. Mount permanently another T. S. cut through the same root a short distance above the first.

Note that this is somewhat larger in diameter. Observe the root hairs starting from the epidermis; a broad cortex; a large clear and open looking endodermis; then pericambium; next, a central patch of xylem showing a faint pentarch relation. Pushed out are five

phloem tracts. Each of these constitutes a mass of protophloem (first formed phloem). On the inner face of each phloem mass may be seen intrafascicular cambium. At the outer end of each xylem tract there has been cut off a patch of fine cambial cells (interfascicular cambium) which becomes joined to the intrafascicular cambium

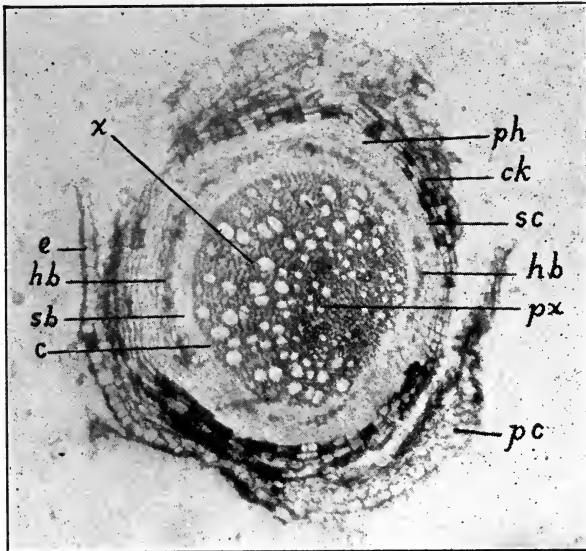

FIG. 62.—Photomicrograph of a transverse section of a California Privet root made about  $1\frac{1}{2}$  inches above the root tip and showing transition structure. The epidermis (*e*), primary cortex (*pc*) and endodermis are in the process of sluffing off, since cork (*ck*) has been laid down by the cork cambium (*ph*) directly beneath the endodermis. The cork cambium has also formed several layers of secondary cortex (*sc*) on its inner face. The protophloem represented largely by hard bast (*hb*) has been pushed out, while a small amount of secondary phloem represented by soft bast (*sb*) has been deposited beneath it by the cambium (*c*) which now is nearly circular in aspect. The protoxylem (*px*) has been pushed into the center by the encroaching secondary xylem (*x*) which has been laid down by the cambium on its inner face. Highly magnified.

to develop secondary phloem on the outer face and secondary xylem on the inner face.

C. Mount permanently a third T. S. out through the same root a short distance above the second. Note that this is still larger in diameter than the second. The pericambium has already divided

into an inner and an outer layer. The outer layer has become the cork cambium, cutting off cork on its outer face beneath the endodermis. Cork being an impermeable barrier to water has prevented the nourishing sap from percolating through to the endodermis, cortex and epidermis. These regions have consequently begun to sluff off. Note that the cambium has begun to spread out into the form

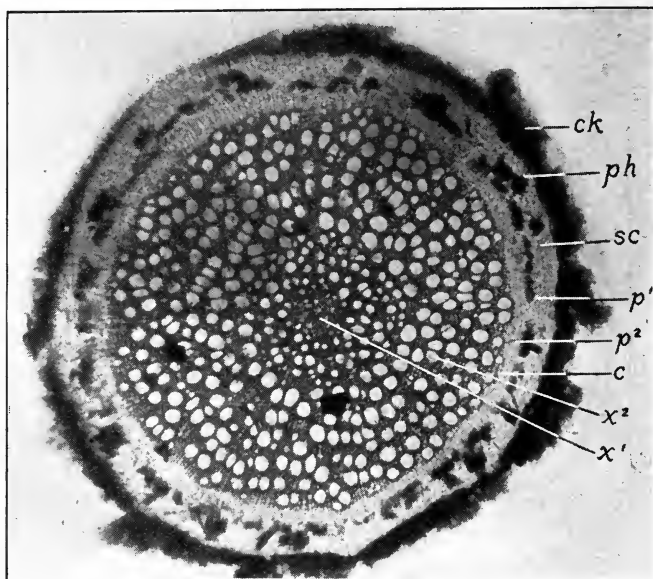

FIG. 63.—Transverse section of California Privet root made about an inch and a half above the section shown in Fig. 61 and showing secondary structure. Note that epidermis, primary cortex and endodermis have completely disappeared. Cork (*ck*); phellogen (*ph*); secondary cortex (*sc*); protophloem (*p'*); secondary phloem (*p*<sup>2</sup>); cambium (*c*); secondary xylem (*x*<sup>2</sup>) and protoxylem (*x'*). (Photomicrograph).

of a ring. More secondary xylem has been formed on its inner face and additional secondary phloem has appeared on its outer face. (Fig. 62.)

D. Make a permanent mount of a fourth T. S. cut through the same root some distance above the third. Note that the epidermis, primary cortex and endodermis have completely peeled off. Cork is found as the external bounding layer and underneath it, cork



cambium. This cork cambium has developed secondary cortex on its inner face. The cambium has assumed a circular aspect. Just beneath the secondary cortex will be found flattened patches of protophloem, and beneath these secondary phloem masses have

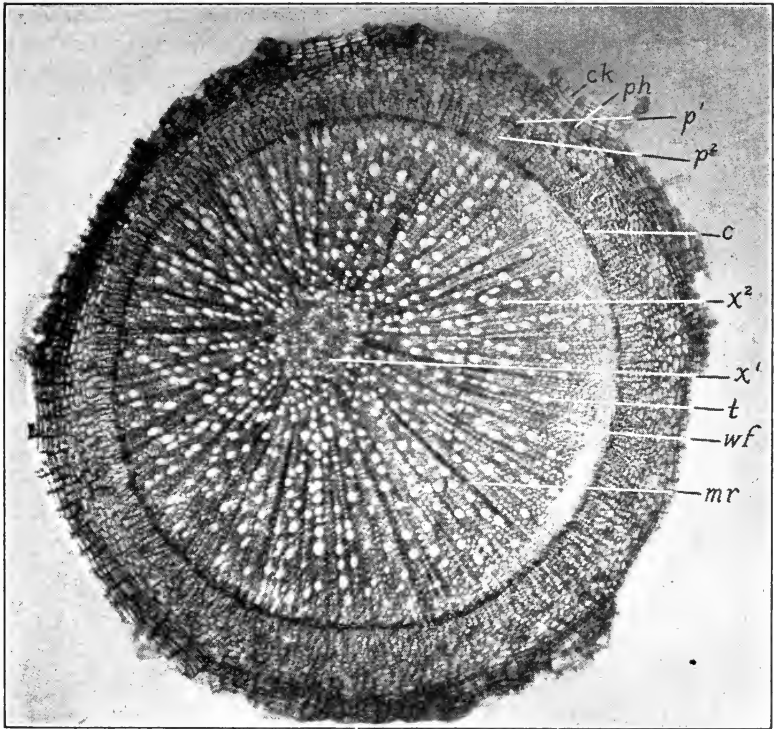

FIG. 64.—Photomicrograph of a transverse section of an old portion of California Privet root, showing completed secondary development. Note the prominent medullary rays (*mr*); cork (*ck*); phellogen (*ph*); secondary cortex (between *ph* and *p'*); protophloem (*p'*); secondary phloem (*p*<sup>2</sup>); cambium (*c*); secondary xylem (*x*<sup>2</sup>); tracheae (*t*); wood fibers (*wf*); and protoxylem (*x'*).

been formed through the activity of the cambium. The cambium has developed new or secondary xylem on its inner face which has pushed the first formed or protoxylem toward the center of the root. (Fig. 63.)

**Abnormal Structure of Dicotyl Roots.**—In certain Dicotyl roots as *Amaranthus*, Jalap, Pareira, and *Phytolacca*, after the normal bundle system has been formed, there then develop successive cambiums outside of these bundles, producing concentric series of open collateral bundles.

**Histology of a Dicotyl Tuberos Root (*Aconitum*).**—A transverse section made through the tuberos root of *Aconitum Napellus* near its middle shows a cork region of one or more layers of blackish or brownish cells; a broad cortex of two regions, viz.: an outer narrower and an inner broader zone. The narrower zone consists of from eight to fifteen layers of cortical parenchyma cells, interspersed among which are numerous irregular-shaped stone cells. Separating this zone from the broader one is an endodermis of a single layer of tangentially elongated endodermal cells. The broader zone consists of about twenty layers of parenchyme cells. Next, a five- to seven-angled cambium, within the angles of which and frequently scattered along the entire cambial line, occur collateral fibro-vascular bundles. In the center is found a broad five- to seven-rayed pith composed of parenchyma cells. The parenchyma cells of the cortical regions and pith contain single or two- to five-compound starch grains.

#### ROOT TUBERCLES

The roots of plants of the *Leguminosæ*, *Myricaceæ* as well as some species of *Aristolochiaceæ* and of the genera *Alnus* and *Ceanothus* are characterized by the appearance upon them of nodule-like swellings called *root tubercles*. In the case of the *Leguminosæ* the causative factor is a species of bacteria named *Pseudomonas radicola*. This is a motile rod-shaped organism which appears widely distributed in soils. It is apparently attracted to the root-hairs of leguminous plants by a chemotactic influence probably due to the secretions poured out by these structures. A number of these organisms penetrate the walls of the root-hairs by enzymic action. Upon entering the hairs they form *bacterial tubes* which branch and rebranch and extend into the middle cortex cells carrying the bacteria with them. Within the cortex cells the organisms multiply rapidly producing nest-like aggregations. Their presence here causes the formation of nodules or tubercles. Under oil-immersion magnification these

bacteria are found to exhibit variously shaped involution forms called *bacterioids*. They remain within the cells of the medio-cortex region gradually swelling up into *zoöglæa* masses, until finally their bodies break down into soluble nitrogenous substances which are partly absorbed and assimilated and partly stored as reserve nitrogenous food for the green leguminous plant.

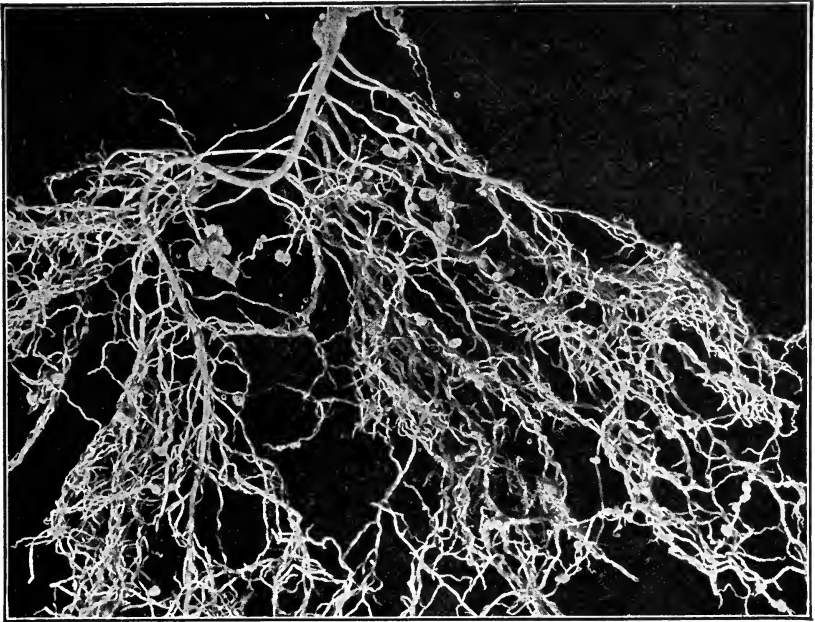

FIG. 65.—Root system of a legume showing tubercles. (Marshall.)

In the modern rotation of crops, plant growers plough under the leguminous crops or their nodule-producing roots which decay and enrich the soil with ample nitrogenous material to supply the next season's crop of nitrogen-consuming plants.

The writer has found tubercles on *Myrica cerifera*, *Myrica Caroliniensis* and *Myrica Macfarlanei* seedling primary roots of 5 to 6 months' growth, and from thence onward on the secondary roots inserted on the hypocotyl axis, on nearly all the adventitious roots of subterranean branches and on the subterranean branches of *Myrica*



FIG. 66.—*Ps. radicicola*. 1, From *Melilotus alba*; 2 and 3, from *Medicago sativa*; 4, from *Vicia villosa*. (Marshall, after Harrison and Barlow from Lipman.)

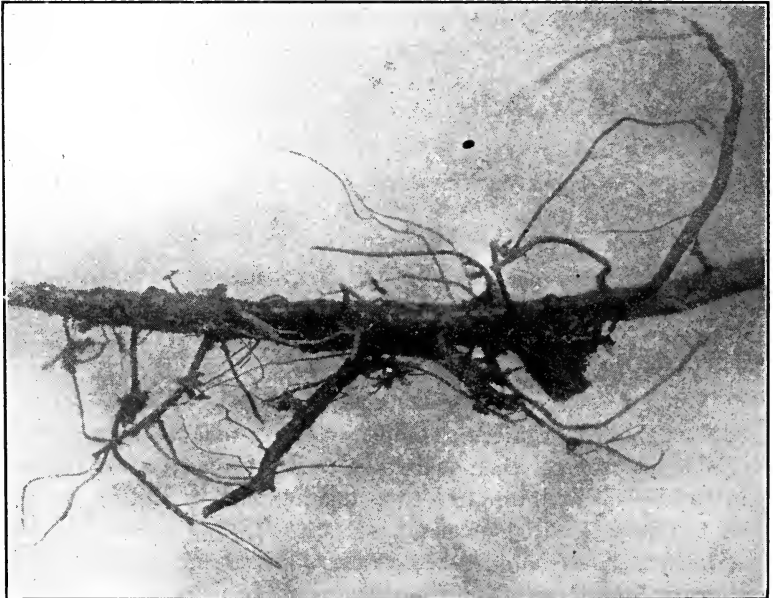

FIG. 67.—Tubercular clusters on underground stem and roots of *Myrica Macfarlanei* observed by the author at North Wildwood, N. J., Jan. 31, 1915.

*cerifera*, *M. Caroliniensis*, *M. Gale*, *M. Macfarlanei*, and *Comptonia asplenifolia*. The inciting organism has been isolated by him in pure culture according to Koch's postulates and named *Actinomyces Myricarum* Youngken.

The tubercles occur either singly, as is frequently the case on subterranean branches, in small groups the size of a pea, or in larger coralloid loose or compact clusters which frequently attain the size of a black walnut. Each tubercle is a short cylindrical blunt-ended root-like structure which branches di- or trichotomously after attaining a certain length. The branches frequently rebranch at their tips which grow out into long thread-like structures from 1-3 cm. in length that may also branch and become entwined about the roots of other plants. The color of the youngest tubercles is a pinkish-gray brown. As the tubercles become older their color changes to brown, dark-brown and even black. (For a detailed description of the *Myrica* and *Comptonia* tubercles and their inciting organism, consult, "The Comparative Morphology, Taxonomy and Distribution of the Myricaceæ of the Eastern United States" by Youngken, in Contributions from the Botanical Laboratory of the University of Pennsylvania, vol. iv, no. 2, 1919.)

## THE BUD

Buds are short young shoots with or without rudimentary leaves (bud scales) compactly arranged upon them.

The *plumule* represents the first bud on the initial stem or caulicle.

*Scaly buds* are such as have their outer leaf rudiments transformed into scales; there are often coated with a waxy or resinous substance without and a downy lining within, to protect them from sudden changes in climate. Buds of this character are common among shrubs and trees of temperate regions.

*Naked buds* are those which are devoid of protective scales. They are common to herbaceous plants.

*Classification of Buds According to Development.*—1. A *leaf bud* is a young shortened shoot bearing a number of small leaves. It is capable of elongating into a branch which bears leaves.

2. A *flower bud* is a rudimentary shoot bearing one or more concealed and unexpanded young flowers.

3. A *mixed bud* is a young shoot bearing concealed unexpanded leaves and flowers.

*Classification of Buds According to Position on the Stem.*—1. A *terminal bud* is one which is located on the end of a stem (shoot). It is capable of elongating into a shoot which bears leaves or both leaves and flowers.

2. An *axillary* or *lateral* bud is one which arises in the leaf axil. It is capable of giving rise to a side branch or to a flower. Occasionally axillary buds do not develop and are then called *dormant buds*.

3. An *adventitious bud* is one which occurs on some position of the stem other than at its apex or in the axil of a leaf. Such buds may be seen developing along the veins of a Begonia leaf or along the margin of a Bryophyllum leaf after these have been planted in moist soil for several days.

4. An *accessory* bud is an extra bud which forms in or near the leaf axil.

*Classification of Buds According to Their Arrangement on the Stem.*

1. When a single bud is found at each joint or *node* of a stem, the buds are said to be *alternate*.

2. When two buds are found at a node they are *opposite*.

3. When several buds occur at a node they are *whorled*.

## THE STEM

The stem is that part of the plant axis which bears leaves or modifications of leaves and its branches are usually arranged with mathematical regularity.

Stems usually grow toward the light and so are heliotropic.

The functions of a stem are to bear leaves or branches, connect roots with leaves, and conduct sap.

When the stem rises above ground and is apparent, the plant is said to be *caulescent*.

When no stem is visible, but only flower or leaf stalks, the plant is said to be *acaulescent*.

Stems vary in size from scarcely  $\frac{1}{25}$  inch in length, as in certain mosses, to a remarkable height of 400 feet or more. The giant Sequoia of California attains the height of 420 feet. Some of the

Eucalyptus trees of Australia and Tasmania are reported to attain the height of 500 feet.

**Nodes and Internodes.**—The nodes are the joints of stems. They represent the parts of the stem from which leaves or branches arise. Internodes are the parts of stems between nodes.

**Direction of Stem Growth.**—Generally the growth of the stem is erect. Very frequently it may be:

*Ascending*, or rising obliquely upward. Example: Saw Palmetto.

*Reclining*, or at first erect but afterward bending over and trailing upon the ground. Example: Raspberry.

*Procumbent*, lying wholly upon the ground. Example: Pipsissewa.

*Decumbent*, when the stem trails and the apex curves upward. Examples: Vines of the *Cucurbitaceæ*.

*Repent*, creeping upon the ground and rooting at the nodes, as the Strawberry.

**Stem Elongation.**—At the tip of the stem there is found a group of very actively dividing cells (meristem) which is the growing point of the stem. All the tissues of the stem are derived from the cells of the growing point whose activity gives rise in time to three generative regions which are from without, inward:

1. *Dermatogen*, forming epidermis;
2. *Periblem*, forming the cortex; and
3. *Plerome*, forming the fibro-vascular elements and pith.

**Duration of Stems.**

*Annual*, the stem of an herb whose life terminates with the season. Examples: Corn.

*Biennial*, where the stem dies at the end of the second year. Example: Burdock.

*Perennial*, when the stem lives for many years. Example: Oak.

**Stem Modifications.**—(1) twining, by elongation and marked circumnutation of young internodes as in *Convolvulus*, *Dodder*, etc. (2) Tendriliform by thread-like modification and sensitivity to contact of a side branch as in Passion flower, Squash, etc. (3) Spiny, by checking and hardening of a branch that may then become defensive ecologically as in hawthorn, honey locust, etc. (4) Aerial tuberous, in which one or more internodes, enlarge above ground and store reserve food as in pseudobulbs of orchids, *Vitis*

*gongyloides*, etc. (5) Subterranean tuberous in which a subterranean stem or branch enlarges as a food-storing center: (a) annual type, tuber as in potato, etc., corm as in crocus, etc.; (b) perennial type, bulbs as in lily (scaly) and onion or hyacinth (tunicated). (6) Phylloid or leaf-like in which flattening branch expansion occurs, when leaves become reduced in size as in *Asparagus*, *Ruscus*, etc. (7) Cactoid, in which reduced condensed branches or stems become swollen for water (and food) storage as in Cacti, *Euphorbia* sp., etc.

**Above-ground Stems.**—A *twining* stem winds around a support, as the stem of a bean or Morning Glory.

A *culm* is a jointed stem of the Grasses and Sedges.

A *climbing* or scandent stem grows upward by attaching itself to some support by means of aerial rootlets, tendrils or petioles. Examples: Ivy, Grape, etc.

The *scape* is a stem rising from the ground and bearing flowers but no leaves, as the dandelion, violet, or blood root.

A *tendril* is a modification of some special organ, as of a leaf stipule or branch, capable of coiling spirally and used by a plant in climbing. Present in the Grape, Pea, etc.

A *spine* or thorn is the indurated termination of a stem tapering to a point, as the thorns of the Honey Locust.

*Prickles* are outgrowths of the epidermis and cortex and are seen in the roses.

A *stolon* is a prostrate branch, the end of which, on coming in contact with the soil, takes root, so giving rise to a new plant. Examples: Currant and Raspberry.

An *herbaceous stem* is one which is soft in texture and readily broken. Example: *Convallaria majalis*.

An *undershrub* or *suffrutose* stem is a stem of small size and woody only at the base. Examples: Bitter-sweet, Thyme, etc.

A *shrubby* or *fruitcose* stem is a woody stem larger than the preceding and freely branching near the ground. Example: Lilac, etc.

A *trunk* is the woody main stem of a tree.

#### HERB AND TREE

A *tree* is a perennial woody plant of considerable size, attaining a height of 15 or more feet, and having as the above-ground parts a trunk and a crown of leafy branches.



There are two plans of branching in trees. When the trunk, or main stem, extends vertically upward to the tip, as it does in the junipers, spruces and other conical trees, the type of branching is called *excurrent*; when it divides into several more or less equal divisions as in the elm and other spreading trees, it is said to be deliquescent. The deliquescent plan is the more common one among our deciduous trees.

An *herb* is a plant whose stem does not become woody and permanent, but dies, at least down to the ground, after flowering.

**Underground Stems.**—A *rhizome* is a creeping underground stem, more or less scaly, sending off roots from its lower surface and stems from its upper. The rhizome grows horizontally, vertically or obliquely, bearing a terminal bud at its tip. Its upper surface is marked with the scars of the bases of aerial stems of previous years. Examples: Triticum, Rhubarb, etc.

The *tuber* is a short and excessively thickened underground stem, borne usually at the end of a slender, creeping branch, and having numerous eyes or buds. Example: Tubers of the Potato.

The *corm* is an underground stem excessively thickened and solid and characterized by the production of buds from the center of the upper surface and rootlets from the lower surface. Examples: Colchicum, Jack-in-the-Pulpit, etc.

A *bulb* is a very short and scaly stem, producing roots from the lower face and leaves and flower from the upper.

*Tunicated bulbs* are completely covered by broad scales which form concentric coatings. Examples: Onion, Squill, Daffodil.

*Scaly bulbs* have narrow imbricated scales, the outer ones not enclosing the inner. Example: Lily.

*Tubers and corms* are annual. *Bulbs and Rhizomes* are perennial.

**Exogenous and Endogenous Stems.**—*Exogenous stems* are typical of Gymnosperms and Dicotyledons and can increase materially in thickness due to presence of a cambium. Such stems show differentiation into an outer or cortical region and an inner or central cylinder region.

*Endogenous stems* are typical of most Monocotyledons and cannot increase materially in thickness due to absence of cambium. The limited increase in diameter that does take place is due to the en-

largement of the cells of the primary tissues. Such stems show no differentiation into cortical and central regions.

**Histology of Annual Dicotyl Stem.**—(In both annual and perennial dicotyledonous stems endodermis and pericambium are rarely seen since each has become so similar to cortex through passage of food, etc.)

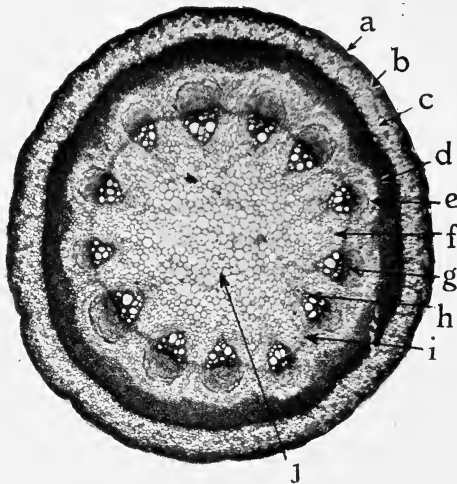

FIG. 68.—Photomicrograph of cross-section of stem of *Aristolochia siphon*, where cambial activity is just beginning. *a*, Epidermis; *b*, collenchyma; *c*, thin-walled parenchyma of the cortex, the innermost cell layer of which is the starch sheath or endodermis; *d*, sclerenchyma ring of the pericycle; *e*, thin-walled parenchyma of the pericycle; *f*, primary medullary ray; *g*, phloem; *h*, xylem; *i*, interfascicular cambium; *j*, medulla or pith.  $\times 20$ . (From Stevens.)

1. Epidermis, cutinized, with hairs.
2. Cortex composed of three zones: an outer or exocortex, whose cells are thin walled and contain chloroplasts; a middle or medio-cortex, consisting of cells of indurated walls giving extreme pliability and strength, an inner or endocortex, a very broad zone of thin- and thick-walled parenchyma cells.
3. The innermost layer of cells of the cortex called endodermis. (Not generally distinguishable.)
4. Pericambium. (Not generally distinguishable.)

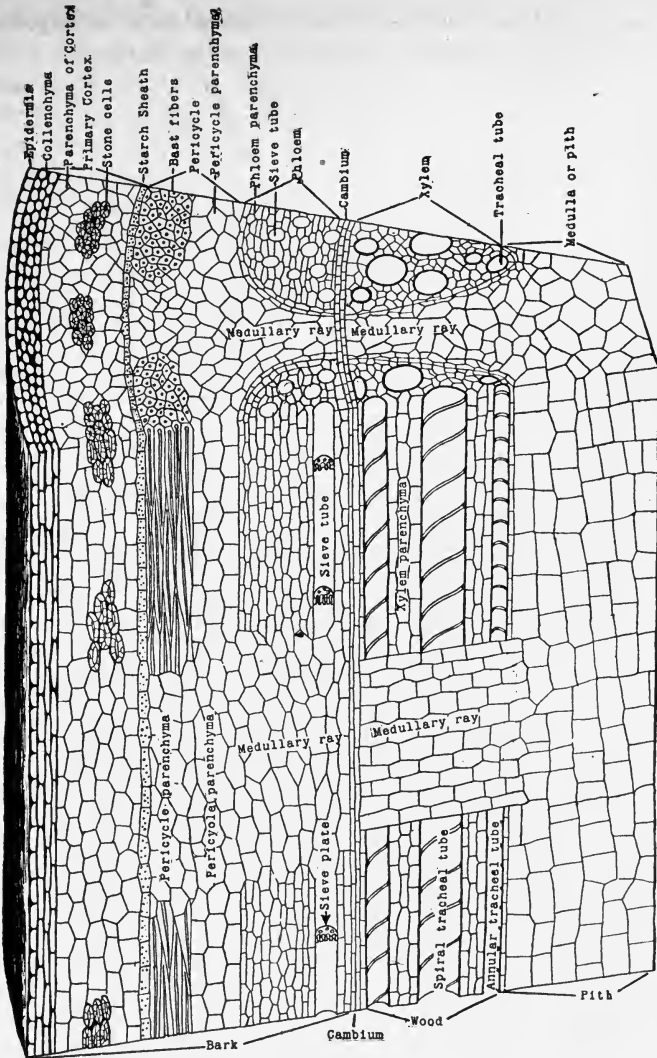

FIG. 69.—A diagram to show the character of the tissues and their disposition in a young stem of the typical dicotyledon type. (From Stevens.)

5. Fibro-vascular bundles of open collateral type arranged in a circle with primary medullary rays between the bundles.
6. Pith.

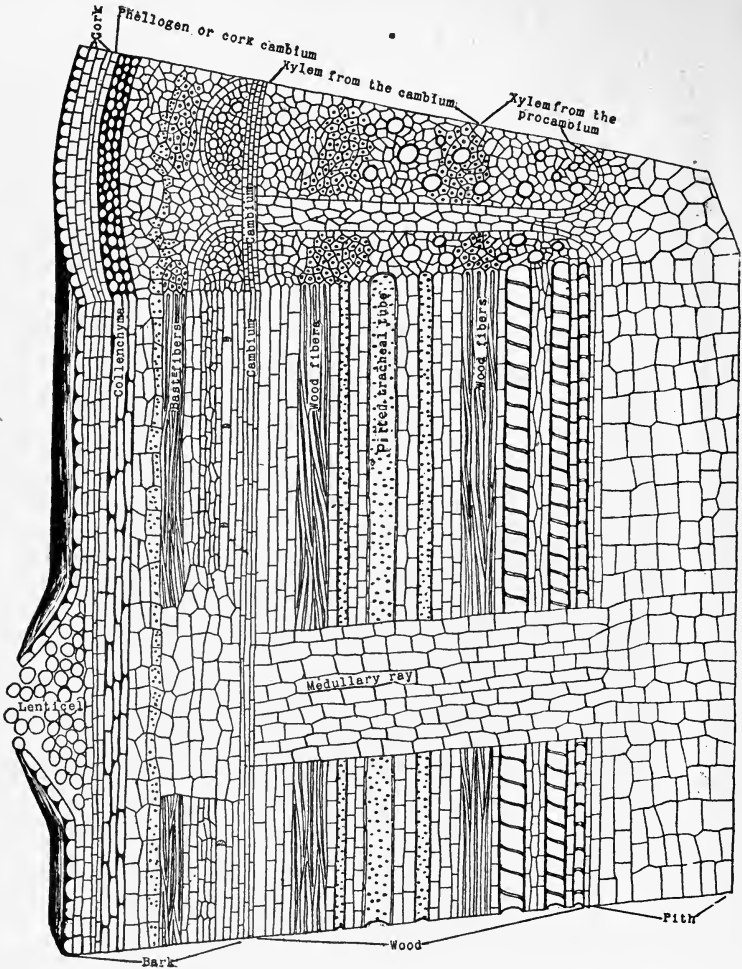

FIG. 70.—Diagram similar to the preceding but representing a later stage and showing the tissues formed by the cambium. (From Stevens.)

**Growth of Perennial Dicotyl Stem and its Histology.**—A perennial dicotyl stem in the first year does not differ in structure from an annual. By the close of the year a cork cambium (phellogen) has originated beside the epidermis. In origin of cork cambium—one of two methods: (a) either the epidermis may divide into an outer layer of cells that remains epidermis and an inner layer of cells that becomes cork cambium, or, (b) the outermost layer of cortex cells underneath the epidermis becomes active after being passive for one year, and lays down walls, the inner layer becoming cork cambium, the outer becoming a layer of cork. The cork cuts off water and food supplies from epidermis outside and so epidermis separates and falls off as a stringy layer. The cork cambium produces cork on its outer face and secondary cortex on its inner.

Between the bundles certain cells of the primary medullary rays become very active and form interfascicular cambium which joins the cambium of the first-formed bundles (intrafascicular cambium) to form a complete cambium ring. By the rapid multiplication of these cambial cells new (secondary) xylem is cut off internally and new (secondary) phloem externally, pushing inward the first-formed, or *protoxylem*, and outward the first-formed, or *protophloem*, thus increasing the diameter of the stem. The primary medullary rays are deepened. Cambium may also give rise to secondary medullary rays.

Sometimes, as in Grape Vines, Honeysuckles, and Asclepias, instead of cork cambium arising from outer cortex cells it may arise at any point in cortex. It is the origin of cork cambium at varying depths that causes extensive sheets of tissue to separate off. That is what gives the stringy appearance to the stems of climbers.

At close of first year in *Perennial Dicotyl Stem* we note:

- |                      |   |   |
|----------------------|---|---|
| Periblem development | { | 1. Epidermis—development of dermatogen or periblem—in process of peeling off, later on entirely absent.   |
|                      |   | 2. Cork tissue or periderm.   |
|                      |   | 3. Cork cambium or phellogen.   |
|                      |   | 4. Sometimes zone of thin-walled cells containing chloroplasts cut off by cork cambium on inner face and known as phelloderm.                               |
|                      |   | 5. Cortex—in perennial stem cells of cortex <i>may</i> undergo modification into mucilage cells, into tannin receptacles, crystal cells, spiral cells, etc. |

Plerome development

6. Fibro-vascular bundles of open collateral type which are now arranged into a compact circle, and between which are found primary and often secondary medullary rays.

From without inward the following tissues make up f. v. bundles.

Protophloem { Hard Bast—long tenacious bast fibers.

Secondary Phloem { Soft Bast—phloem cells and sieve tubes.

Cambium—active layer giving rise to secondary phloem on outer and secondary xylem or inner face, and adding to depth of med. rays.

Secondary xylem—wood fibers, pitted vessels, tracheids.

Protoxylem—spiral tracheæ.

7. Pith.

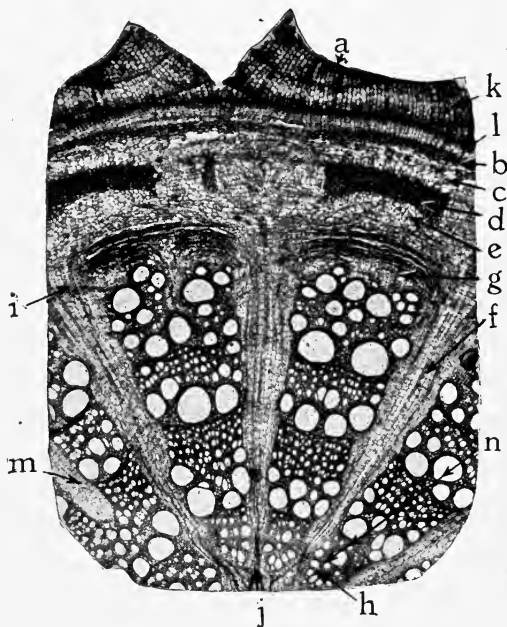

FIG. 71.—Portion of cross-section of four-year-old stem of *Aristolochia sipho*, as shown by the rings of growth in the wood. The letters are the same as in Fig. 68 but new tissues have been added by the activity of the cambium; and a cork cambium has arisen from the outermost collenchyma cells and given rise to cork. The new tissues are; *l*, cork cambium; *k*, cork; *g*, secondary phloem from the cambium, and just outside this is older crushed phloem; *n*, secondary xylem produced by the cambium; *m*, secondary medullary ray made by the cambium (notice that this does not extend to the pith). Half of the pith is shown. Notice how it has been crushed almost out of existence. Compare Figs. 68 and 71, tissue for tissue, to find out what changes the primary tissues undergo with age, and to what extent new tissues are added. Photomicrograph  $\times 20$ . (From Stevens.)

## EXCEPTIONAL TYPES OF DICOTYL STEMS

In a number of Dicotyledons and Gymnosperms, the secondary growth in thickness of the stem and frequently of the root differs from that which is found in the vast majority of species and so is called exceptional or anomalous.

In *Phytolacca*, etc., there first arises a ring of primary bundles with broad loose medullary rays. Then the stem cambium ceases its

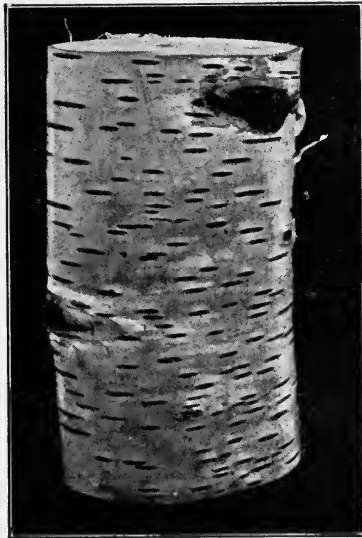

FIG. 72.—White birch (*Betula populifolia*). Portion of a branch showing the prominent lenticels. (Gager.)

activity, and, outside the bast of the bundles already formed in the pericambium or tissue developing from it, a new cambium starts to lay down another ring of bundles in rather irregular fashion. Then after developing a wavy ring of bundles and connecting tissue that cambium closes up. Still another cambium ring arises without this, and in a single season quite a number of these are found successively arranged in concentric fashion.

In *Gelsemium*, species of *Solanaceæ*, *Combretaceæ*, *Cucurbitaceæ*, etc., there arises a cambium on the inner face of the xylem which

forms *internal phloem* (or *intraxylary phloem*), thus giving rise to bicollateral bundles.

In *Strychnos Nux Vomica* internal phloem exactly as in *Gelsemium*, etc., appears but in addition *interxylary phloem* is developed. In the wood region of this plant axis the cambium starts at a certain age to lay down patches of phloem which become wedged in between xylem tissue as interxylary phloem.

**Lenticels and Their Formation.**—The epidermis in a great majority of cases produces stomata, apertures, surrounded by a pair of guard cells, which function as passages for gases and watery vapor from and to the active cells of the cortex beneath.

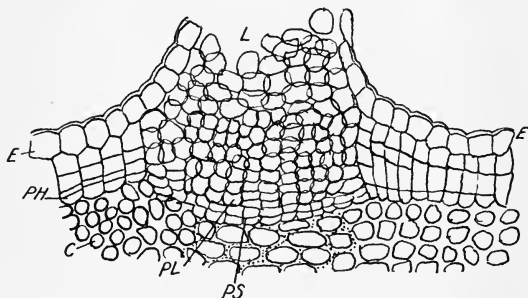

FIG. 73.—Cross-section through a lenticel of *Sambucus nigra*. *E*, Epidermis; *PH*, phellogen; *L*, loosely disposed cells of the lenticel; *PL*, cambium of the lenticel; *PS*, phelloderm; *C*, cortical parenchyma containing chlorophyll. (From Sayre after Strasburger.)

They very early originate in the region beneath the stomata as loosely arranged cells from cork cambium which swell up during rain and rupture, forming convex fissures in the cork layer, called lenticels.

The function of lenticels is similar to that of stomata, namely, to permit of aëration of delicate cells of the cortex beneath.

**Annual Thickening.**—In all woody exogenous stems such as trees and shrubs the persistent cambium gives rise to secondary xylem thickening every spring, summer and autumn. Soon a great cylinder of xylem arises which constitutes the wood of the trunk and branches. In the spring, growth is more active, and large ducts with little woody fiber are produced while in summer and autumn



growth is lessened and small ducts and much mechanical woody fiber are formed. Thus the open, loosely arranged product of the spring growth abuts on the densely arranged product of the last summer and autumn growth and the sharp contrast marks the periods of growth. To the spring, summer and autumn regions of growth of each year is given the term of "annual ring." By counting the number of these rings it is possible to estimate the age of the tree or branch.

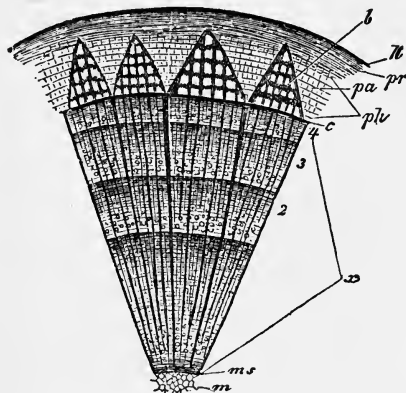

FIG. 74.—Part of a transverse section of a twig of the linden, four years old. *m*, Pith; *ms*, medullary sheath; *x*, secondary wood; *Ph*, phloem; 2, 3, 4, annual rings; *c*, cambium; *pa*, dilated outer ends of medullary rays; *b*, bast; *pr*, primary cortex; *k*, cork. (From Sayre after Vines.)

**Bark.**—Bark or bork is a term applied to all that portion of a woody exogenous plant axis outside of the cambium line.

In pharmacognic work, bark is divided into three zones, these from without inward being:

1. *Outer Bark* or *Cork*.
2. *Middle Bark* or *Cortical Parenchyma*.
3. *Inner Bark* or *Phloem*.

**Periderm.**—Periderm is a name applied to all the tissue produced externally by the cork cambium (*Phellogen*). This term appears often in pharmacognic and materia medica texts.

**Phelloderm.**—Phelloderm or secondary cortex is all that tissue produced by the cork cambium on its inner face. Its cells frequently contain chloroplasts.

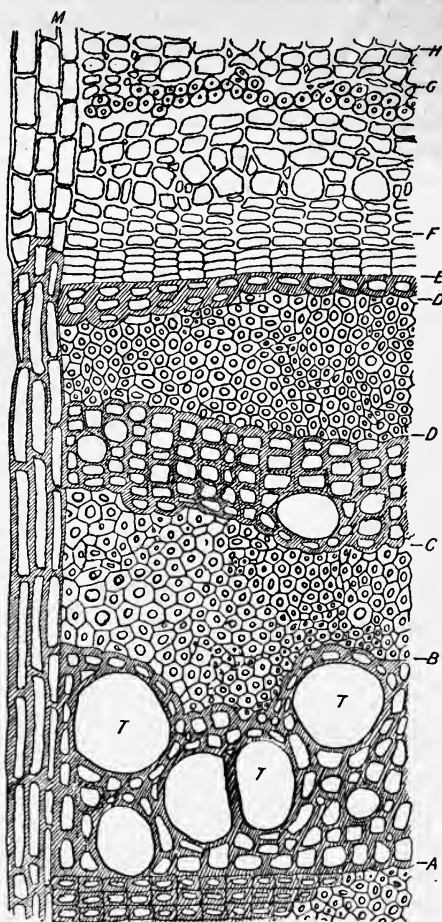

FIG. 75.—Part of a cross-section through branch of *Cytisus laburnum*. (The branch was cut from the tree at the end of October.) From A to E the last annual ring of wood; from A to B the spring growth with large tracheal tubes (T, T, T); between B and C and D and D are wood-fibers; between C and D and D and E, wood parenchyma; from E to F, cambium; F to G, phloem portion; G to H, cortical parenchyma; M, medullary ray. Below A the last wood-fibers and wood parenchyma formed the previous year. (From Sayre after Haberlandt.)

**Histology of a Typical Bark, *Cascara Sagrada*.**—*In transverse section* passing from outer to inner surface, the following structural characteristics are evident:

1. **Cork**, or outer bark, composed of several layers of rectangular cork cells. The most external layers are dead and appear black because they are filled with air. The inner layers of this region are living and contain brownish contents.

2. **Cork cambium** (phellogen), a layer of delicate cells with protoplasmic contents in the process of division.

3. **Cortex**, or middle bark, consisting of two regions, viz.: an outer zone of two or three rows of brownish collenchyma cells, and an inner broader *zone* of tangentially elongated cortical parenchyma cells. Imbedded within this zone will be noted numerous groups of stone cells.

4. **Phloem, or inner bark**, a very broad zone composed of irregular-shaped, elongated phloem masses separated from each other by medullary rays which converge in the outer phloem region. Each phloem mass consists of numerous sieve tubes and phloem cells, some of which latter contain spheroidal starch grains while others contain monoclinic prisms or rosette aggregates of calcium oxalate. Imbedded within the phloem masses in tier-like fashion will be noted groups of bast fibers, each group of which is surrounded by a row of crystal fibers, individual cells of which can only be made out in this kind of a section. Each of these contains a monoclinic prism of calcium oxalate. The medullary rays possess brownish contents which take a red color with an alkaline solution.

*In radial longitudinal section* a lengthwise view of the tissues will be seen. The medullary rays appear 15 to 25 cells in height and crossing at right angles to the other elements. The crystal fibers here will be seen to be composed of vertical rows of superimposed thin-walled cells each of which contains a monoclinic prism of calcium oxalate. The bast fibers appear elongated and taper ended and are associated with crystal fibers.

*In a tangential longitudinal section* which has been cut through the phloem, the exact range in width of the medullary rays may be ascertained. In this bark the medullary rays are spindle-shaped in tangential view and one to four cells in width.

**Wood.**—From a pharmacognic standpoint as well as that of the lumber trade, wood is all that portion of woody exogenous plant axis inside of the cambium line. In Dicotyl and Gymnosperm stems it therefore includes the xylem regions of the bundles, the

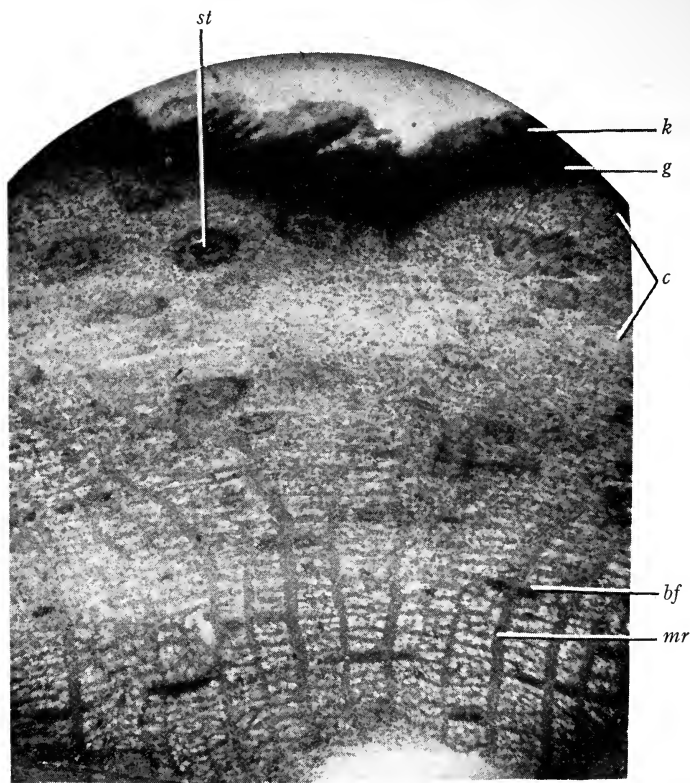

FIG. 76.—Photomicrograph of transverse section of Cascara Sagrada bark; *k*, cork; *g*, cork cambium; *c*, cortex; *st*, group of stone cells; *bf*, group of bast fibers; *mr*, medullary ray.

xylem portions of the medullary rays and the pith, while in the roots of secondary growth of these plants it comprises the xylem portions of the bundles and the xylem medullary rays.

As the cambium year after year adds new layers of wood to that already present on its inner face, the conveying of sap and storing

of starch, etc. is gradually relegated to the outer wood layers, since the inner layers, step by step, lose their protoplasmic contents and

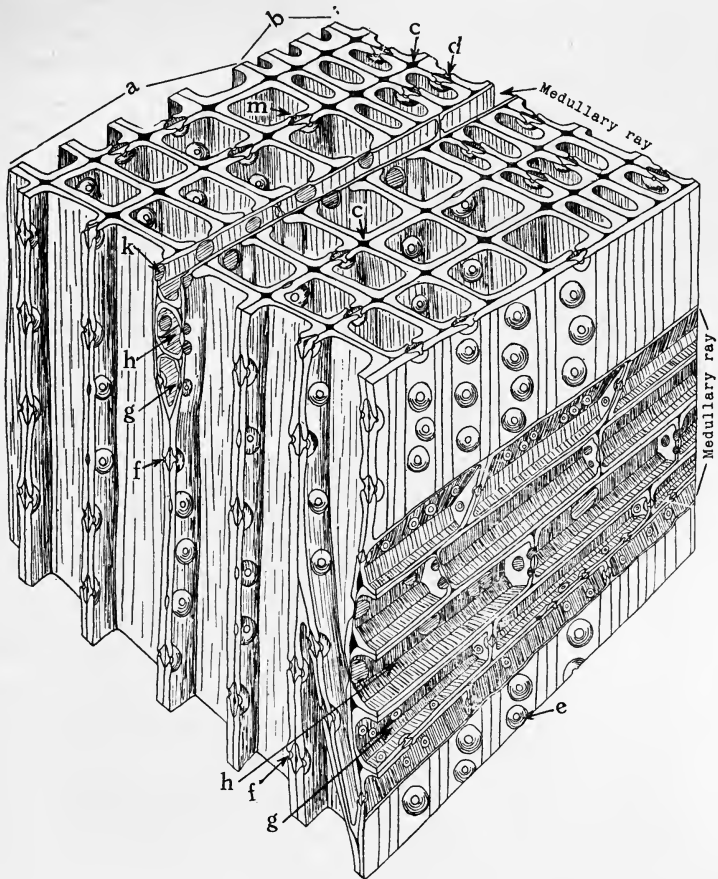

FIG. 77.—Diagrammatic representation of a block of pine wood highly magnified. *a*, Early growth; *b*, late growth; *c*, intercellular space; *d*, bordered pit in tangential wall of late growth; *m*, *f* and *e*, bordered pit in radial wall of early growth from different points of view; *h*, row of medullary cells for carrying food; *g*, row of medullary ray cells for carrying water; *k*, thin place in radial wall of ray cells that carry food (From Stevens.)

power of conducting sap and become filled with extractive, resinous and coloring matters. The outer whitish layers of wood which con-

tain living cells, functioning in the vegetative processes of the plant, constitute the *alburnum* or *sap-wood*. The drug Quassia is a good example of this kind of wood. The inner dead colored layers constitute the *duramen* or *heart-wood*. Important examples of this kind of wood used in pharmacy are Lignum Guaiaci, Hæmatoxylum, and Santalum Album.

**Microscopic Characteristics of Angiospermous and Gymnospermous Woods.**—The wood of Angiosperms is characterized by the presence of *tracheæ* (vessels) with various markings on their walls, particularly by small pits in the walls of some of the *tracheæ*, together with wood fibers, wood parenchyma and medullary rays.

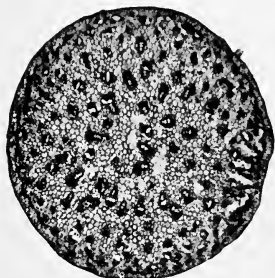

FIG. 78.—Photomicrograph of cross-section of very young cornstalk, where certain plerome strands have just gone over into vascular bundles. For comparison with Fig. 79. (Stevens.)

The wood of Gymnosperms is made up for the larger part of tracheids with bordered pits which latter are characterized in radial longitudinal section by the presence of two rings, one within the other. A single row of these is seen on the tracheid wall. Medullary rays, frequently diagnostic for different species and woody parenchyma cells, are also found.

**Histology of Typical Herbaceous Monocotyl Stems (Endogenous).**—Passing from exterior toward center the following structures are seen:

1. Epidermis whose cells are cutinized in their outer walls.
2. Hypodermis, generally collenchymatic.
3. Cortex.
4. Endodermis or innermost layer of cortex.
5. A large central zone of parenchyma matrix in which are found scattered fibro-vascular bundles of the closed collateral or rarely concentric type (amphivasal). In this latter type, which is typical of old monocotyl stems, the xylem grows completely around phloem so that phloem is found in the center and xylem without and surrounding it.

**Histology of a Typical Woody Monocotyl Stem.**—The stem of the Greenbrier, a woody monocotyl, will here be considered. In transverse section passing from periphery toward the center the following structural details will be noted:

1. *Epidermis*, of a single layer of epidermal cells whose outer walls are strongly cutinized. Cutin is a wax-like substance which forms a protective coat to the epidermis, preventing the evaporation of water, the ingress of destructive parasites, and injury from insects.

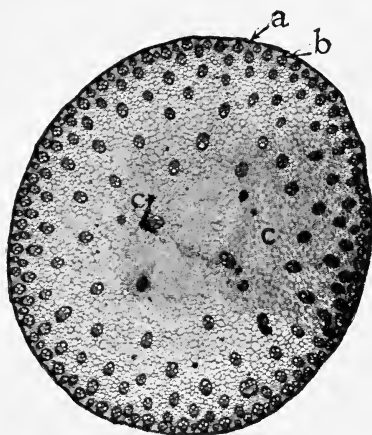

FIG. 79.—Cross-section of cornstalk stem; a, epidermis; b, cortex and c, ground tissue. (After Stevens.)

2. A *cortex*, composed of about ten or twelve layers of thick-walled parenchyma cells, the outer two or three layers of which are termed hypodermis.

3. An *endodermis*, wavy in character and composed of endodermal cells whose brownish walls are strongly suberized.

4. A sclerenchymatous *cylinder sheath* composed of somewhat separated masses of sclerenchymatous fibers and undeveloped fibrovascular bundles of the closed collateral type.

5. A *central matrix* of strongly thickened parenchyma cells in which are scattered, irregularly, numerous closed collateral bundles. Small starch grains will be found in the parenchyma cells. Examine a representative bundle, and note the two very large tracheæ and

several smaller ones in the xylem portion of the bundle which faces toward the center of the section. In the outer or phloem portion of the bundle will be seen an area of soft, small-celled sieve tubes and phloem parenchyme. The entire bundle is enclosed by a several

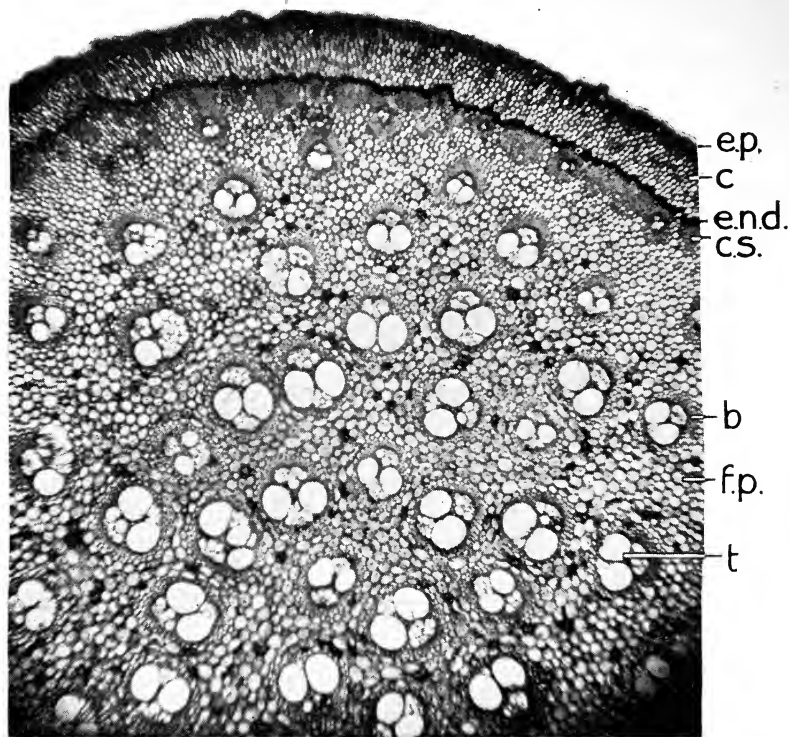

FIG. 80.—Photomicrograph of a representative portion of Greenbrier stem showing epidermis (*e.p.*), cortex (*c*), endodermis (*e.n.d.*), cylinder sheath (*c.s.*), sclerenchyma fibers of closed collateral bundle (*b*), fundamental parenchyma (*f.p.*), trachea (*t*).  $\times 22$ .

layered ring of sclerenchyma fibers, which on the inner face are called wood fibers, on the outer, bast fibers. The wood fibers constitute the supporting elements of the xylem, while the bast fibers are the supporting elements of the phloem.



## THE LEAF

The leaf is a usually flattened, rarely semi-centric, or centric-lateral expanse developed by the stem or by branches and in whose axil one or more branches arise.

Leaves seldom develop buds over their surface or along their margin and in connection therewith roots. The capacity for bud development is restricted to three families, viz.: *Crassulaceæ*, *Begoniaceæ* and *Gesneraceæ*.

*Leaf Functions.*—The most essential function of plants is the conversion of inorganic into organic matter; this takes place ordinarily in the green parts, containing chlorophyll, and in these when exposed to sunlight. Foliage is an adaptation for increasing the extent of green surface.

The functions of a leaf are photosynthesis, assimilation, respiration and transpiration.

**Photosynthesis** is the process possessed by all green leaves or other green parts of plants of building up sugar, starch or other complex organic substances by means of chlorophyll and sunlight. This process takes place in nature, only during sunlight.  $\text{CO}_2$  is taken in and O given off.

**Assimilation** is the process of converting food material into protoplasm.

**Respiration** or breathing is the gaseous interchange whereby all living organisms take in oxygen and give off carbon dioxide.

**Transpiration** is the giving off of watery vapor.

**Types of Leaves Developed in Angiosperms.**—These may be tabulated as follows:

1. Cotyledons (the primitive or seed leaves).
2. Scale leaves.
3. Foliage leaves.
4. Bract leaves: (*a*) primary at base of inflorescence: (*b*) bracteolar leaves at a base of individual flowers.
5. Sepals.
6. Petals.
7. Microsporophylls (stamens).
8. Megasporophylls (carpels).

**Cotyledons.**—Cotyledons are the first leaves to appear upon the ascending axis and are single in Monocotyledons, double in Dicotyledons. Occasionally, as in certain Maples, there may be three cotyledons shown. This is due to a splitting of one of the cotyledons. There exist no true cases of polycotyledony (development of many cotyledons) among Angiosperms, as in Gymnosperms. In Monocotyledons the single cotyledon is a terminal structure and truly axial in relation to the hypocotyl and radicle. From a primitively Monocotyl-like ancestry Dicotyledons develop a second cotyledon on the Epicotyledonary node. Later, by a suppression of the second node the second cotyledon is brought to the level of the first.

**Scale Leaves.**—Scale leaves are reduced foliage leaves. They are found on certain rhizomes, above ground stems, such as Dodder, etc., on bulbs, and forming the protective scales of scaly buds.

**Foliage Leaves.**—These are the common green leaves so familiar to all.

**Bract leaves** are modified leaves appearing on inflorescence axes.

**Sepals, petals, microsporophylls and megasporophylls** are floral leaves and will be treated at length under the subject of the flower.

**Origin and Development of Leaves.**—Leaves arise around the growing apex region of a stem or branch as lateral outgrowths, each consisting at first of a mass of cells called the primordial leaf. Through continued cell-division and differentiation of these cells in time the mature leaf is developed. The primordial leaf is formed by a portion of the dermatogen of the growing stem apex, which becomes epidermis, a portion of the periblem, producing mesophyll which grows into this, and a part of the plerome, which becomes vascular tissue within the mesophyll.

In the sub-divisions of cells around the growing stem-apex, the primordial leaves (primordia) do not arise exactly at the same time. There is a tendency toward spiral arrangement.

**Phyllotaxy.**—Phyllotaxy is the study of leaf arrangement upon the stem or branch, and this may be either alternate, opposite, whorled, or verticillate, or fascicled. It is a general law in the arrangement of leaves and of all other plant appendages that they are spirally disposed, or on a line which winds around the axis like the thread of a screw. The spiral line is formed by the union of

two motions, the circular and the longitudinal, and its most common modification is the circle.

In the *alternate* arrangement there is but one leaf produced at each node. Examples: Aconite, Magnolias.

*Opposite*, when a pair of leaves is developed at each node, on opposite sides of the stem. Examples: Mints, Lilac.

*Decussate*, when the leaves are arranged in pairs successively along the stem, at right angles to each other. Example: Thoroughwort.

*Whorled* or *Verticillate*, when three or more form a circle about the stem. Examples: Canada Lily and Culver's root.

*Fascicled* or *Tufted*, when a cluster of leaves is borne from a single node, as in the Larch and Pine.

The spiral arrangement is said to be two-ranked, when the third leaf is over the first, as in all Grasses; three-ranked, when the fourth is over the first. Example: Sedges. The five-ranked arrangement is the most common, and in this the sixth leaf is directly over the first, two turns being made around the stem to reach it. Example: Cherry, Apple, Peach, Oak and Willow, etc. As the distance between any two leaves is two-fifths of the circumference of the stem, the five-ranked arrangement is expressed by the fraction  $\frac{2}{5}$ . In the eight-ranked arrangement the ninth leaf stands over the first, and three turns are required to reach it, hence the fraction  $\frac{3}{8}$  expresses it. Of the series of fractions thus obtained, the numerator represents the number of turns to complete a cycle, or to reach the leaf which is directly over the first; the denominator, the number of perpendicular rows on the stem, or the number of leaves, counting along the spiral, from any one to the one directly above it.

**Vernation.**—*Præfoliation* or *Vernation* relates to the way in which leaves are disposed in the bud. A study of the individual leaf enables us to distinguish the following forms. When the apex is bent inward toward the base, as in the leaf of the Tulip Tree, it is said to be

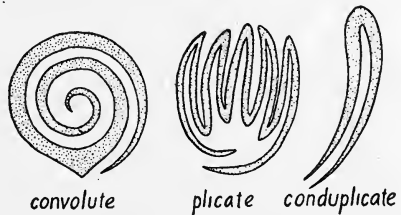

FIG. 81.—Three principal types of vernation. (Robbins.)

*inflexed* or *reclinate* *vernation*; if doubled on the midrib so that the two halves are brought together as in the Oak or Peach, it is *conduplicate*; when rolled inward from one margin to the other, as in the Wild Cherry, it is *convolute*; when rolled from apex to base, as in Ferns, it is *circinate*; when folded or plaited, like a fan as in Ricinus, Maples, Aralias, etc., it is *plicate*; if rolled inward from each margin toward the midrib on the upper side, as the leaves of the Apple or Violet, *involute*; when rolled outward from each margin as

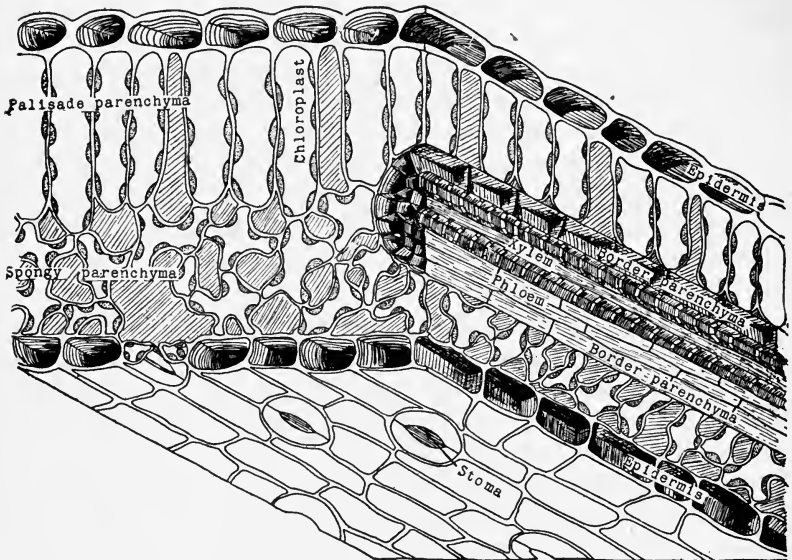

FIG. 82.—Stereogram of leaf structure. Part of a veinlet is shown on the right. Intercellular spaces are shaded. (From Stevens.)

Dock or Willow leaves, *revolute*. The inner surface is always that which will form the upper surface when expanded.

**The Complete Leaf.**—The leaf when complete consists of three parts, *lamina*, *petiole*, and *stipules*. The lamina or blade is the expansion of the stem into a more or less delicate framework, made up of the branching vessels of the petiole.

The petiole is the leaf stalk. The stipules are leaf-like appendages appearing at the base of the petiole.

The leaf of the Tulip Poplar or *Liriodendron* affords a good example of a *Complete Leaf*.

Sometimes the lamina or blade is attached directly to the stem by its base and is then said to be *sessile*. If the petiole is present, *petiolate*.

When leaf stipules are absent, the leaf is said to be *exstipulate*, when present, *stipulate*.

The petiole is seldom cylindrical in form, but usually channelled on the upper side, flattened, or compressed. The stipules are always in pairs and closely resemble the leaf in structure.

The blade of the leaf consists of the framework, made up of branching vessels of the petiole, which are woody tubes pervading the soft tissue called mesophyll, or leaf parenchyma, and serve not only as supports but as veins to conduct nutritive fluids. Veins are absent in simple leaves such as many of the Mosses.

**Leaf Venation.**—*Furcate* or *Forked Venation* is characteristic of many Ferns.

*Parallel Venation* is typical of the *Monocotyledons*, as Palms, Lilies, Grasses, etc.

*Reticulate* or *Netted Veins* characterize the *Dicotyledons*, as the Poplar or Oak. The primary veins in these are generally pinnate while the secondary ones and their branches are arranged in netted fashion.

*Pinni-veined* or *Feathered-veined* leaves consist of a mid-vein with lateral veinlets extending from mid-vein to margin at frequent intervals and in a regular manner. Example: Calla.

*Palmately Veined* leaves consist of a number of veins of nearly the same size, radiating from petiole to margin. Example: Maple leaf.

Veins are said to be *anastomosing* when they subdivide and join each other, as the veins near the margin of *Eucalyptus* leaves.

**Leaf Insertion.**—The point of attachment of the leaf to the stem is called the insertion. A leaf is:

*Radical*, when inserted upon an underground stem.

*Cauline*, when upon an aerial stem.

*Ramal*, when attached directly to a branch.

When the base of a sessile leaf is extended completely around the stem it is *perfoliate*, the stem appearing to pass through the blade. Example: *Uvularia perfoliata* or Mealy Bellwort.

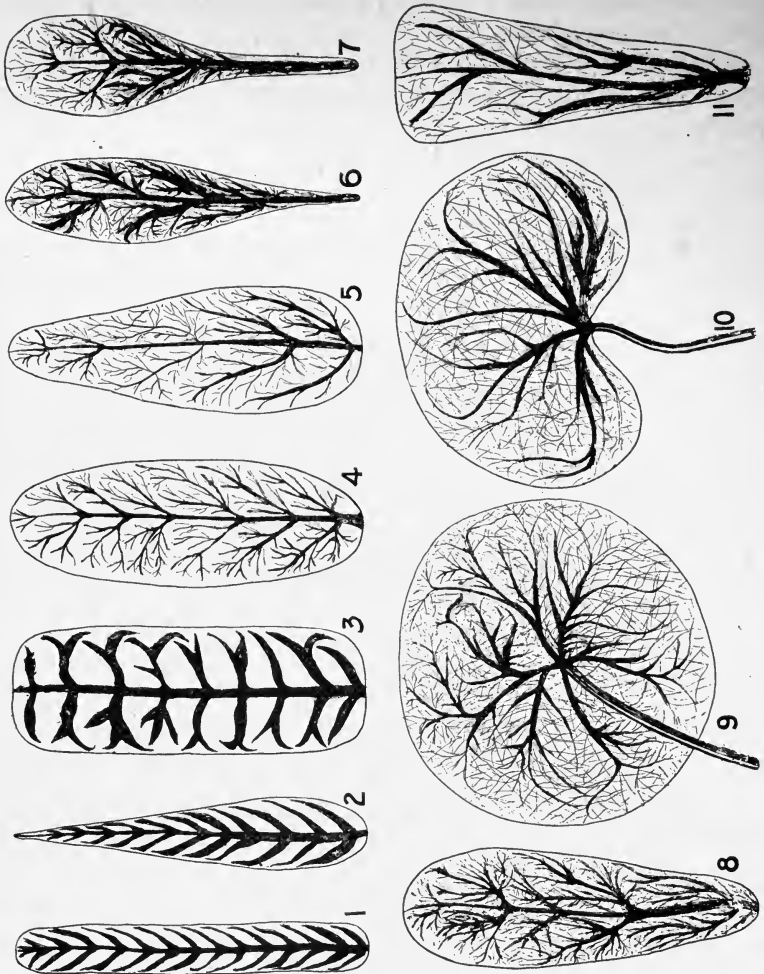

FIG. 83.—Leaf outlines: Linear (1); lanceolate (2); oblong (3); elliptical (4); ovate-lanceolate (5); oblanceolate (6); spatulate (7); obovate-lanceolate (8); orbicular (9); reniform (10); cuneate (11).

When a sessile leaf surrounds the stem more or less at the base, it is called *clasping* or *amplexicaul*. Example: Poppy (*Papaver somniferum*).

When the bases of two opposite leaves are so united as to form one piece, they are called *connate-perfoliate*, as *Eupatorium perfoliatum* or Boneset.

Leaves are called *equitant* when they are all radical and successively folded on each other toward their bases, as in *Iris sp.*

**The Forms of Leaves.**—*Simple leaves* are those having a single blade, either sessile or petiolate.

*Compound leaves* are divided into two or more distinct subdivisions called leaflets, which may be either sessile or petiolate.

Simple leaves and the separate blades of compound leaves are described as to general outline, apex, base, marginal indentations, surface and texture.

(a) *General Outline* (form viewed as a whole without regard to indentations of margin). Dependent upon kind of venation.

When the lower veins are longer and larger than the others, the leaf is *Ovate*, or Egg-shaped. Parallel-veined leaves are usually *linear*, long and narrow of nearly equal breadth throughout (*Linaria*), or *lanceolate*, like the linear with the exception that the broadest part is a little below the center. Example: Long Buchu.

*Elliptical*, somewhat longer than wide, with rounded ends and sides. Example: Leaf of Pear.

*Oblong*, when longer than broad, margins parallel. Example: Matico.

*Inequilateral*, margin longer on one side than the other, as the Hamamelis, Elm and Linden.

*Orbicular*, circular in shape. Example: Nasturtium.

*Peltate*, or shield-shaped, having the petiole inserted at the center of the lower surface of the lamina. Example: Podophyllum.

*Filiform*, or *thread-like*, very long and narrow, as Asparagus leaves.

*Ovate*, broadly elliptical. Example: Boldo. *Obovate*, reversely ovate. Examples: Short Buchu and Menyanthes.

*Oblanceolate*, reversely lanceolate. Example: Chimaphila.

*Cuneate*, shaped like a wedge with the point backward.

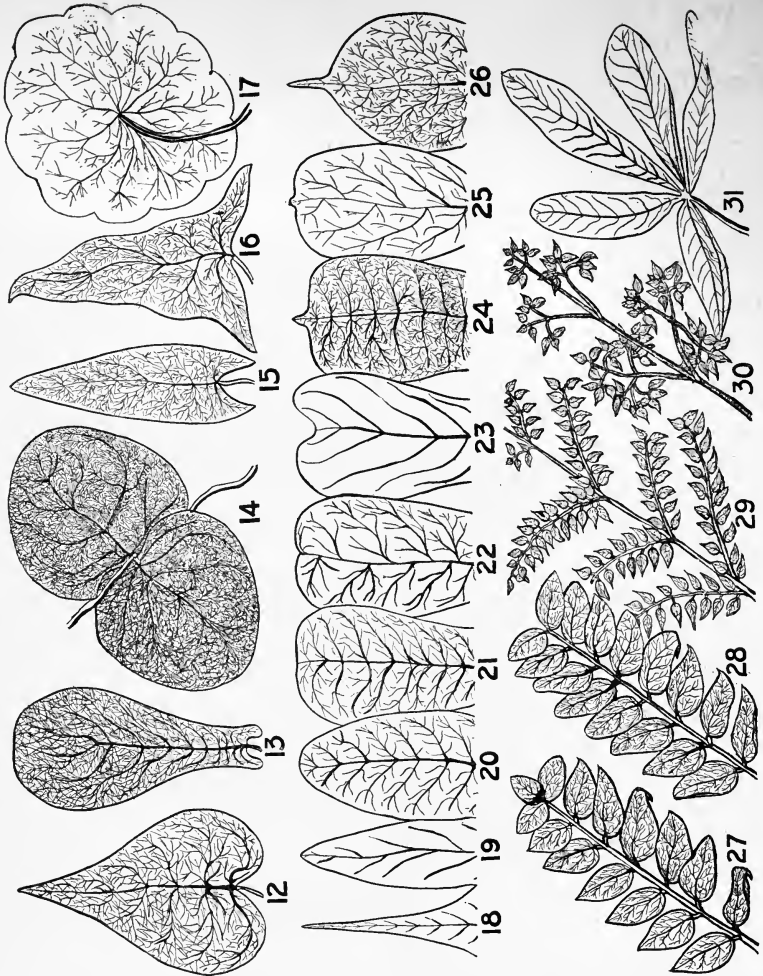

FIG. 84.—Leaf bases (12–17); leaf apices (18–26); compound leaves (27–31). Cordate (12); auriculate (13); connate-perfoliate (14); sagittate (15); hastate (16); peltate (17). Acuminate (18); acute (19); obtuse (20); truncate (21); retuse (22); emarginate (23); cuspidate (24); mucronate (25); aristate (26). Imparipinnate (27); paripinnate (28); bi-pinnate (29); decompound (30); palmately 5-foliolate (31).



*Spatulate*, like a spatula, with narrow base and broad rounded apex. Example: *Uva Ursi*.

*Ensiform*, when shaped like a sword. Example: *Calamus*.

*Acerose* or *acicular*, tipped with a needle-like point, as *Juniper*.

*Falcate*, sythe or sickle shaped as *Eucalyptus*.

*Deltoid*, when the shape of the Greek letter  $\Delta$ , as *Chenopodium*.

(b) **Apex of Leaf**.—*Acute*, when the margins form an acute angle at the tip of the leaf. Examples: *Eriodictyon*, *Digitalis*.

*Acuminate*, when the point is longer and more tapering than the acute. Examples: *Pellitory*, *Coffee*.

*Obtuse*, blunt or round. Example: *Long Buchu*.

*Truncate*, abruptly obtuse, as if cut square off. Example: *Melilotus* leaflets.

*Mucronate*, terminating in a short, soft point. Example: *Senna* leaflets.

*Cuspidate*, like the last, except that the point is long and rigid.

*Aristate*, with the apex terminating in a bristle.

*Emarginate*, notched. Example: *Pilocarpus*.

*Retuse*, with a broad, shallow sinus at the apex. Example: Petal of *Rosa gallica*.

*Obcordate*, inversely heart-shaped. Example: *Oxalis*.

(c) **Base or Leaf**.—*Cordate*, heart-shaped. Examples: *Lime* and *Coltsfoot*.

*Reniform*, kidney-shaped. Examples: *Ground Ivy*, *Asarum*.

*Hastate*, or halbert-shaped, when the lobes point outward from the petiole. Example: *Aristolochia Serpentina*.

*Auriculate*, having ear-like appendages at the base. Example: *Philodendron*.

*Sagittate*, arrow-shaped. Example: *Bindweed*.

*Cuneate*, wedge shaped. Examples: *Short Buchu* and *Uva Ursi*.

(d) **Margin of Leaf**.—*Entire*, when the margin is an even line. Example: *Belladonna*.

*Serrate*, with sharp teeth which incline forward like the teeth of a hand-saw. Examples: *Peppermint*, *Yerba Santa*, *Buchu*.

*Dentate*, or toothed, with outwardly projecting teeth. *Chestnut*.

*Crenate*, or Scalloped, similar to the preceding forms, but with the teeth much rounded. Examples: *Digitalis*, *Salvia*.

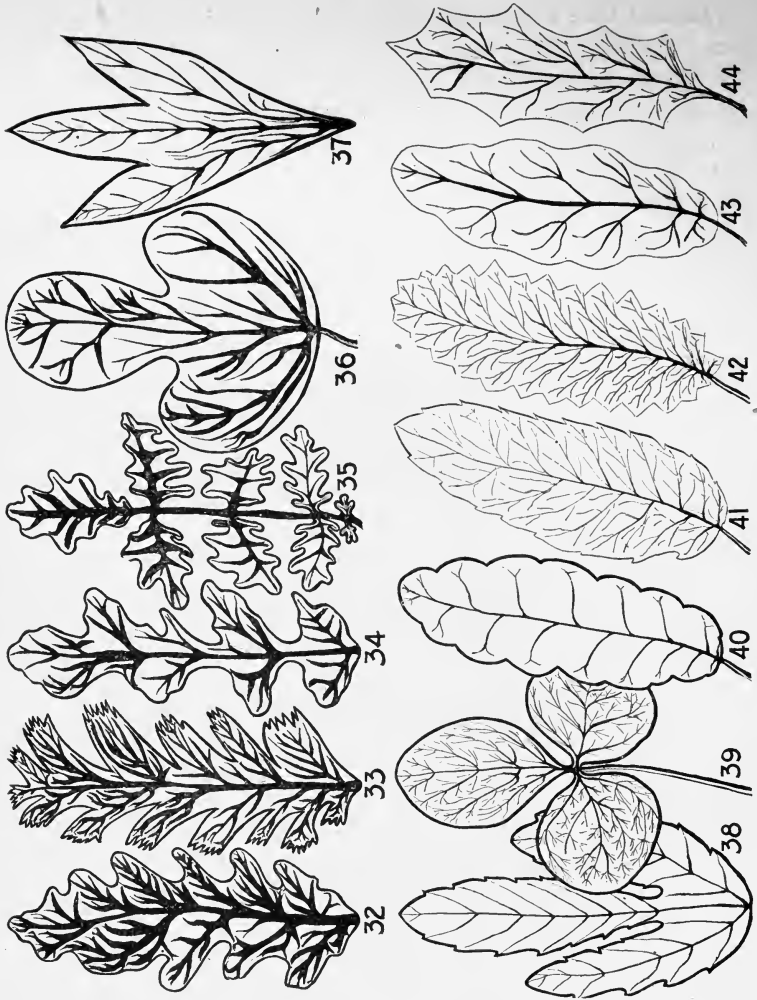

FIG. 85.—Leaf margins: Pinnately-lobed (32); pinnately-cleft (33); pinnately-parted (34); pinnately-divided (35); palmately tri-lobed (36); palmately tri-cleft (37); palmately 3-parted (38); palmately 3-divided (39); crenate (40); serrate (41); dentate (42); repand or undulate (43); sinuate-dentate (44).

*Repand*, or *Undulate*, margin—a wavy line. Example: *Hamelis*.

*Sinuate*, when the margin is more distinctly sinuous than the last. (*Stramonium*.)

*Incised*, cut by sharp, irregular incisions. Example: Hawthorn.

*Runcinate*, the peculiar form of pinnately incised leaf observed in the Dandelion and some other *Compositæ* in which the teeth are recurved.

A *Lobed* leaf is one in which the indentations extend toward the mid-rib, or the apex of the petiole, the segments or sinuses, or both, being rounded. Example: *Sassafras*.

*Cleft* is the same as lobed, except that the sinuses are deeper, and commonly acute. Example: Dandelion.

A *Parted* leaf is one in which the incisions extend nearly to the mid-rib or the petiole. Example: *Geranium maculatum*.

In the *Divided* leaf the incisions extend to the mid-rib, or the petiole, but the segments are not stalked. Example: Watercress.

If the venation is pinnate, the preceding forms may be described as pinnately incised, lobed, parted, or divided. If the venation is radiate, then the terms radiately or palmately lobed, incised, etc., are employed.

The transition from Simple to Compound Leaves is a very gradual one, so that in many instances it is difficult to determine whether a given form is to be regarded as simple or compound. The number and arrangement of the parts of a compound leaf correspond with the mode of venation, and the same descriptive terms are applied to outline, margin, etc., as in simple leaves.

Leaves are either *pinnately* or *palmately compounded*. The term pinnate is frequently given to the former while that of palmate is often assigned to the latter. They are said to be abruptly pinnate or *paripinnate* when the leaf is terminated by a pair of leaflets; odd pinnate or *imparipinnate* when it terminates with a single leaflet. When the leaflets are alternately large and small, the leaf is *interruptedly pinnate*, as the Potato leaf. When the terminal leaflet is the largest, and the remaining ones diminish in size toward the base the form is known as *lyrate*, illustrated in the leaf of the Turnip.

Palmately compound leaves have the leaflets attached to the

apex of the petiole. When these are two in number the leaf is *bifoliate*, or *binate*; if three in number, *trifoliate*, or *ternate*, as in *Menyanthes*; when four in number, *quadrifoliate*, etc. If each of the leaflets of a palmately compound leaf divides into three, the leaf is called *biterminate*; if this form again divides, a *triterminate* leaf results. Beyond this point the leaf is known as *decompound*. In the case of pinnately-compound leaves, when division progresses so as to separate what would be a leaflet into two or more, the leaf becomes *bipinnate*, as the compound leaves of *Acacia Senegal* or on the new wood of *Gleditschia*; if these become again divided, as in many *Acacia* species, the leaf is termed *tripinnate*. Examples of decompound leaves seen in *Cimicifuga* and Parsley.

**Leaf Texture.**—Leaves are described as:

*Membranous*, when thin and pliable, as *Coca*.

*Succulent*, when thick and fleshy, as *Aloes*, and *Live Forever*.

*Coriaceous*, when thick and leathery, as *Eucalyptus*, *Uva Ursi* and *Magnolia*.

**Leaf Color.**—*Petaloid*, when of some brilliant color different from the usual green, as the *Coleus* and *Begonia*, and other plants which are prized for the beauty of their foliage rather than their blossoms.

**Leaf Surface.**—Any plant surface is:

*Glabrous*, when perfectly smooth and free from hairs or protuberances. Example: *Tulip*.

*Glaucous*, when covered with bloom, as the *Cabbage* leaf.

*Pellucid-punctate*, when dotted with oil glands, as the leaves of the *Orange* family.

*Scabrous* leaves have a rough surface with minute, hard points.

*Pubescent*, covered with short, soft hairs. Example: *Strawberry*.

*Villose*, covered with long and shaggy hairs. Example: *Forget-me-not*.

*Sericious*, silky. Example: *Silverleaf*.

*Hispid*, when covered with short, stiff hairs. Example: *Borage*.

*Tomentose*, densely pubescent and felt-like, as the *Mullein* leaf.

*Spinose*, beset with spines, as in the *Thistle*.

*Rugose*, when wrinkled. Example: *Sage*.

*Verrucose*, covered with protuberances or warts, as the calyx of *Chenopodium*.

**Duration of Leaves.**—Leaves vary as to their period of duration. They are: *Persistent*, or *evergreen*, if they remain green on the tree for a year or more.

*Deciduous*, if unfolding in spring and falling in autumn.

*Caducous*, or *fugacious*, if falling early in the season.

**Parts of Typical Leaf.**—The parts of a typical leaf are *petiole* or leaf stalk, *lamina* or blade, and *stipules*.

**Gross Structure and Histology of the Petiole.**—The *petiole* in Monocotyledons is usually a broadened, sheathing basal structure which connects the lamina to the stem. Into this a set of closed collateral vascular bundles of the stem extend, these showing xylem uppermost and phloem beneath; but in the *Palmaceæ*, *Araceæ*, *Dioscoreaceæ* and *Musaceæ* the petiole in part or throughout may be much thickened, strengthened and developed as a semi-cylindric or cylindric structure frequently showing, as in *Palmaceæ*, generally, two sets of bundles. In all of these the petiole shows distinct scattered closed collateral bundles embedded in parenchyma and surrounded by epidermis. In the Monocotyl genus *Maranta* a special swelling is found at the apex of the petiole which is termed a *pulvinus*.

In Dicotyledons the petiole attains its most perfect development and here usually shows differentiation into a pulvinus or leaf cushion and stalk portion. The pulvinus is sensitive to environal stimuli and in some groups as *Oxalidaceæ* and *Leguminosæ* a gradual increase in sensitivity up to a perfect response can be traced. Moreover, in these, if we start with the simpler less sensitive pulvini and pass by stages to the most complex, we note that a special substance known as the *aggregation body* develops in the pulvinar cortex cells and that this substance undergoes rapid molecular change on stimulation of the leaf. The stalk portion of the petiole in Dicotyledons is usually plano-convex or nearly to quite circular in outline; rarely in certain families does it simulate Monocotyledons in becoming abruptly or gradually thinned or flattened or widened out so as to sheath round the stem. The most striking example of this is seen in the *Umbelliferæ* where the flattened sheathing leaf stalk is known as the *pericladium*. Such a structure is not peculiar to the *Umbelliferæ* for in many *Ranunculaceæ*, etc., a similar sheathing development is observed. The stalk may bear the laminar tissue on its extremity.

This is most commonly the rule, but when the plant is exposed to xerophytic conditions, as the Acacias of Australia, the stalk, instead of being cylindrical or sub-cylindrical, becomes flattened from side to side, until there is produced a bifacial vertically placed petiole, with a large green surface that wholly takes the place of the lamina.

The *petiolar structure* in primitive types of Dicotyls resembles that seen in Monocotyls except that the bundles are more condensed side by side. In these the petiole is somewhat dorsiventral, shows an external epidermis, a flattened cortex with a set of parallel vascular bundles, each with xylem uppermost and phloem below. From this we pass to another group in which the bundles form three-fourths of a circle and in which the upper bundles show incurving orientation, to still another in which, as in *Nepenthes*, all of the bundles form nearly a cylinder. Finally in *Ficus*, *Geranium*, *Podophyllum* and other plants showing completely formed cylindrical petioles, the bundles form a continuous ring enclosing pith and surrounded by cortex and epidermis, as in Dicotyl stems.

**Stipules.**—Stipules are lateral leafy or membranous outgrowths from the base of the petiole at its junction with the stem. They may be divided into two groups, viz.: *lateral* and *axillary*. The *lateral group* includes four types, namely, free lateral, lateral adnate, lateral connate and lateral interpetiolar.

Free lateral stipules are seen in *Leguminosæ*, *Rosaceæ*, Beeches, etc. They are free on either side of the petiole and supplied by vascular tissue from the petiolar bundle mass. In appearance and duration they may be either green, foliaceous and persistent or membranous to leathery, scale-like and caducous. Caducous scaly stipules only function as bud scales through the winter and fall in spring as the buds expand.

Lateral adnate stipules are such as fuse with and are carried up with the petiole as wing-like appendages. This type is seen in the genus *Rosa*, in Clovers, etc.

Lateral connate stipules are such as join and run up with the petiole to form a structure which is called a *ligule*. This structure is common to the Gramineæ or Grass family.

Lateral interpetiolar stipules are common to many species of the *Rubiaceæ*. In the genus *Cinchona* the leaves are opposite and orig-

inally had free lateral stipules which latter gradually fused with the stem, slid across it and adjacent stipules, then fused together to form a median structure on either side of the stem.

The *axillary group* represent stipules which stand in the axil of the leaf with the stem. Such may be free axillary structures, arising as distinct processes, or connate, when the two stipules unite at their margins and sheath the stem, as in many species of the *Polygonaceæ* such as Buckwheat, Rhubarb, Yellow Dock, Knot Weeds, etc. The sheath formed is called an *ochrea*.

**Modified Stipules.**—In some plants such as the Locust and several other trees and shrubs of the Legume family, the stipules become modified for defensive purposes as spines or prickles. In the Sarsaparilla-yielding plants and other species of the genus *Smilax* they undergo modification into tendrils which are useful in climbing.

*The Lamina.*—This as was previously indicated represents an expansion of the tissues of the petiole, but in sessile leaves is directly attached to the stem and so a direct stem outgrowth.

**Mode of Development of the Lamina of Leaves.**—The lamina of leaves develops in one of six ways.

1. Normal or Dorsoventral.
2. Convergent.
3. Centric.
4. Bifacial.
5. Reversed.
6. Ob-dorsi-ventral.

The first four will be considered.

A. **Dorsoventral** (the commonest).

(a) *Dorsoventral Umbrophytic.*—Flattened from above downward. Plants with such leafblades tend to grow in the shade.

(b) *Dorsoventral Mesophytic.*—Similar to the former, but plants usually grow directly in the open and exposed to sunlight and winds.

(c) *Dorsoventral Xerophytic.*—Similar to former, but plants not only grow exposed, but exposed to hot desert conditions or to cold vigorous conditions.

(d) *Dorsoventral Hydrophytic.*—All transitions between typical mesophytic forms to those of marshy places, to swamps and borders of streams and finally with leaves wholly emersed, the last a completely hydrophytic type.

**Gross Structure and Histology of Different Types of Dorsoventral Leaf Blades.**—1. **Umbrophytic.**—Characterized by leaves mostly undivided and having the largest and most continuous leaf expanse. Usually the deepest green leaves we have, to enable the leaves to

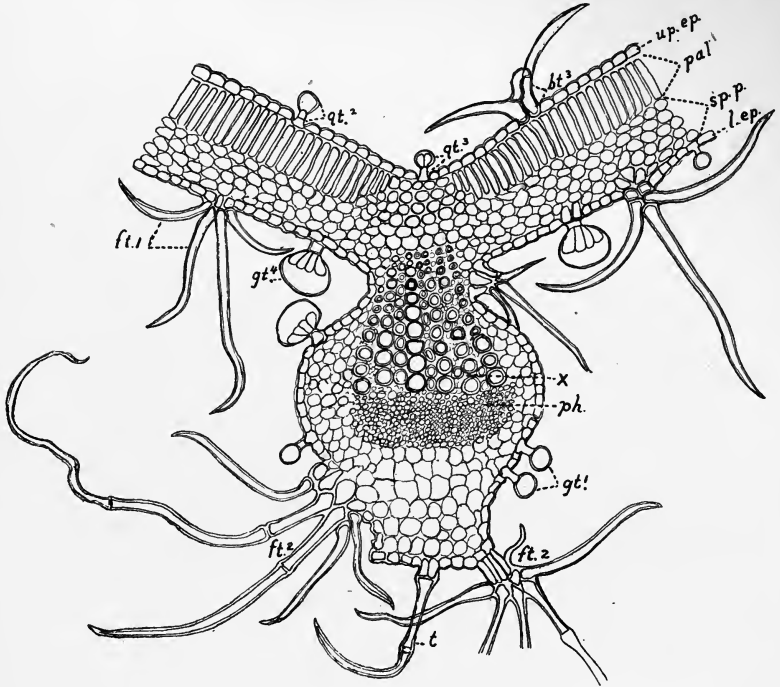

FIG. 86.—Transverse section through portion of dorsoventral leaf blade of horehound (*Marrubium vulgare*). Upper epidermis devoid of stomata (*up.ep.*); lower epidermis which possesses stomata (*l.ep.*); palisade parenchyma (*pal.*); spongy parenchyma (*sp.p.*); xylem (*x*) and phloem (*ph.*) regions of fibrovascular tissue of stronger vein; long-pointed non-glandular trichome (*l.*); branched trichomes (*ft.<sup>1</sup>*, *ft.<sup>2</sup>*, *ft.<sup>3</sup>*); several types of glandular trichomes (*gt.<sup>1</sup>*, *gt.<sup>2</sup>*, *gt.<sup>3</sup>*, *gt.<sup>4</sup>*).

absorb scattered and reduced rays that pass in through high trees and shrub overhead. Their texture is usually thin and soft. In microscopic structure they are covered with a cutinized epidermis which has all the stomata on the lower surface. The mesophyll is fairly spongy, the spongy parenchyma having decided intercellular



spaces. The lower epidermis is more or less hairy. Examples: Dog's Tooth Violet, Asteis.

2. **Mesophytic.**—Leaves tend to subdivision, either to slight or moderate lobing, seldom to complete subdivision in pinnate or tripinnate fashion. Example: Dandelion. In microscopic structure, they consist of an upper and lower epidermis, the upper epider-

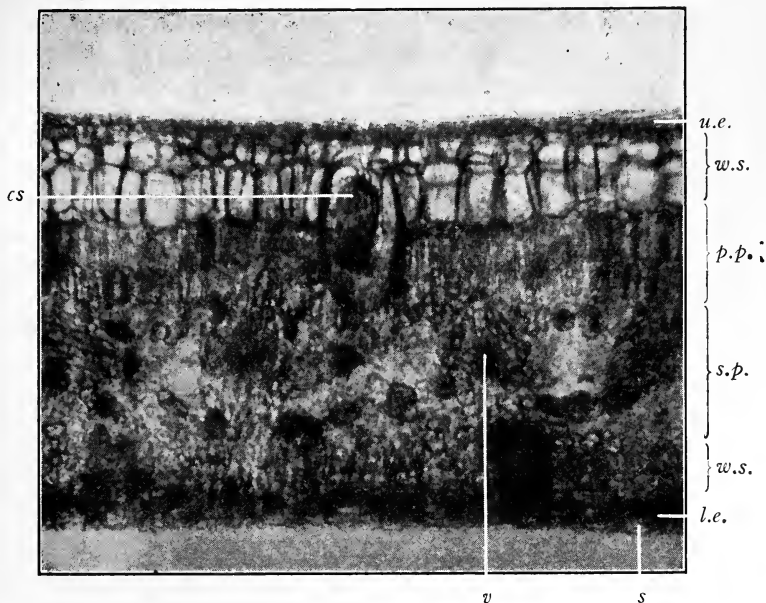

FIG. 87.—Photomicrograph of cross-section through a portion of the leaf of a xerophyte, *Ficus elastica*, showing upper epidermis (*u.e.*), water storage tissue (*w.s.*), cystolith suspended on stalk within a cystolith sac (*cys*), palisade parenchyma (*p.p.*), spongy parenchyma (*s.p.*), vein (*v*), lower epidermis (*l.e.*), and stoma (*s*). (Highly magnified.)

mis being the thicker of the two. The stomata are wholly or are mainly on the lower epidermis. Hairs are seldom seen. The palisade mesophyll is toward the upper surface, the spongy mesophyll toward the lower. The intercellular-air-spaces in the spongy parenchyma are small.

3. **Xerophytic.**—Leaves characterized by a thick upper and lower cuticle and by having their numerous, small stomata restricted to

the lower surface or present more or less equally on both surfaces, where they are sunken in depressions. They may be either firm, leathery, tough, fibrous, or may become swollen up in their mesophyll chiefly in their spongy parenchyme cells and store considerable mucilage. Examples: *Yucca*, *Ficus*, *Aloe*, *Agave*. Succulent forms like *Aloe* generally possess a thin but tenacious cuticle.

4. **Hydrophytic.**—All gradations are seen. In pond plants, such as the Water Lily, the leaves have long split petioles which bring the blade up to the surface of the water. The stomata are entirely on the upper surface. In *Ranunculus*, the lower leaves are cut up into filiform segments. These are devoid of stomata. Their mesophyll is soft, open, and spongy. The epidermis is quite thin. The upper leaves are floating, trilobed, and have stomata only on their upper surface. In *Utricularia*, some of the filiform submerged leaves are modified into bladders which trap insect larvæ and smaller Crustaceæ.

B. **Convergent.**—In *Phormium tenax*, the base of the blade is sheathing, it then converges and opens out above. In the various species of *Iris* the petiole is sheathing, the upper part being fused (mostly seen in monocotyls).

C. **Centric.**—*Succulent.*—Nearly always associated with Xerophytes.

*Xerophytic.*—Centric laminæ are produced gradually by an encroachment of the under on the upper surface, and the swelling of the whole. In a completely centric leaf of the succulent kind, like that of *Sedum*, the difference between the upper and lower surface is lost. Stomata are found scattered over the entire epidermis. The bundles are arranged in a circle, the mid-rib being in the center. A great deal of mucilage is found stored in the central cells. In a typical Xerophytic Centric leaf, like that of the Pine or *Sansevieria cylindrica*, the epidermis shows a thick cuticle; the stomata are sunken in cavities of the epidermis; the epidermis and leaf tissue are strengthened by scleroid bands in the centric mesophyll.

D. **Bifacial.**—Leaves with laminæ which stand edge on in relation to the sun's rays. The best illustrations are seen among dicotyledons, such as *Eucalyptus*, *Callistemon*, and other genera of *Myrtaceæ*. Both surfaces are similar, having stomata about equal in

number. The mesophyll is differentiated into a central spongy parenchyme containing bundles, and a zone of palisade cells on either side facing the epidermises.

**Structure and Development of Stomata.**—Stomata are slit-like openings in the epidermis of leaves or young green stems surrounded

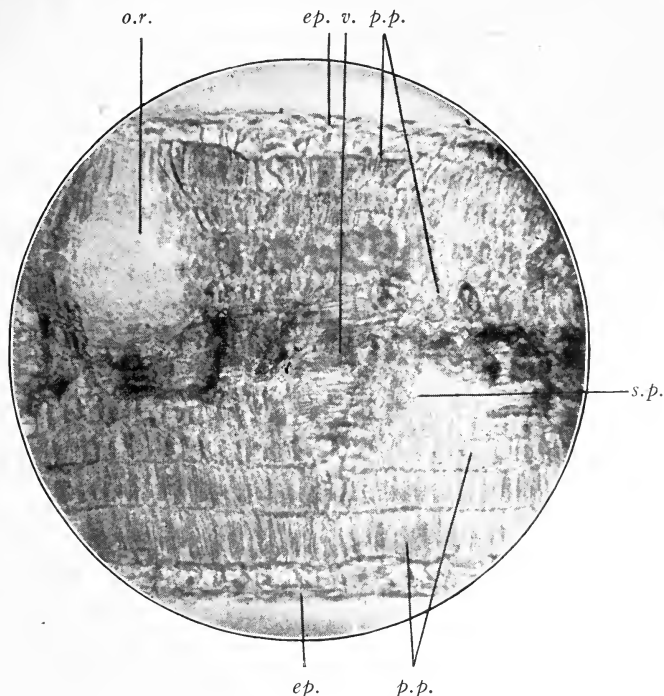

FIG. 88.—Photomicrograph of a transverse section of a bifacial leaf of *Eucalyptus globulus* showing epidermis (*ep.*), palisade parenchyma (*p.p.*), toward both surfaces, spongy parenchyma (*s.p.*), vein (*v*), and oil reservoir (*o.r.*) lined with secretory epithelium. (Highly magnified.)

by a pair of cells, called guard cells, whose sides opposite one another are concave. They form a communication between the intercellular-air-space (respiratory cavity) beneath them and the exterior. The slit-like opening taken with the guard cells, constitutes what is known as the stomatal apparatus.

The epidermal cells which abut on the stomatal apparatus are called *neighboring cells* or *subsidiary cells*. These in many cases, as in species of *Helleborus*, *Sambucus*, *Hyacinthus*, *Pæonia*, Ferns, etc., are very similar to the other epidermal cells, but in a large number of plants they differ in size, arrangement and shape from the other cells of the epidermis which do not abut upon the stomatal apparatus. In *Senna* they are two in number one larger than the other and arranged parallel to the guard cells of the stoma; in *Coca* a similar arrangement occurs but the cells are more even in size, nevertheless they lack the characteristic papillæ found on the other epidermal cells; in *Pilocarpus* they are usually four in number but quite narrow and more or less crescent-shaped; in *Uva Ursi* their number is usually seven to eight and their arrangement radial around the stomata apparatus.

On all dorsoventral leaves, the stomata arise more abundantly on the lower epidermis, less abundantly on the upper. Exceptions to this rule are due to the peculiar readaptation of the leaf to its surroundings. Thus, in the reversed types of leaves (twisted in a half circle) the stomata, formerly on the lower surface, have migrated to the upper surface which now has become the physiological lower surface.

In Umbrophytic (shade) plants the stomata are either wholly on the lower surface or partly so with a number on the upper surface. Where the plants are Mesophytic and exposed to dense sunlight and leaves remain dorsoventral, the stomata are on the lower surface; these stomata are large, if the surroundings are damp. If such plants live in dry soil and dry air, the stomata are of small size and numerous; if they dwell in dry soil in hot surroundings and dense light they are very small and frequently sunk. If the plants are Xerophytic and the leaves dorsoventral, the stomata are quite abundant, small, with narrow slit, and depressed below the level of the epidermis.

There are five types of stomatal development, viz.:

**First Type.**—Each primitive epidermal cell (or the majority, or only certain ones of the epidermis) at the close of the dermatogen stage, gradually lengthens and then cuts off a smaller from a larger cell. The smaller one is equilateral, has a very large nucleus, and is termed the *Stoma Mother-cell*; the larger, quadrangular, and called

the *Epidermal Daughter-cell*. The latter, upon maturing, becomes a normal epidermal cell. A partition is laid down lengthwise through the *Stoma Mother-cell* dividing it into two stomatal daughter-cells. The wall laid down lengthwise splits and thus forms the orifice of the stoma; the cells on either side of the orifice are called *Guard Cells*.

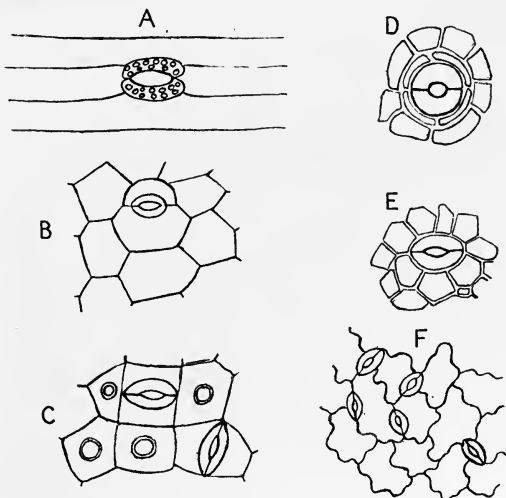

FIG. 89.—Types of stomatal apparatuses and neighboring cells from different sources. In A, a portion of the lower epidermis of Easter Lily leaf: The stomatal apparatus is surrounded by neighboring cells that are similar to other epidermal cells adjacent to them; in B, lower epidermis of Senna leaflet, note the two neighboring cells parallel to the guard cells, one being larger than the other; C, lower epidermis of Coca leaf showing two neighboring cells, parallel to the guard cells but nearly equal in size as well as papillated regular epidermal cells; D, lower epidermis of Pilocarpus showing rounded stomatal apparatus and four crescent-shaped neighboring cells; E, lower epidermis of Uva Ursi, showing eight neighboring cells arranged radiately around stomatal apparatus; F, lower epidermis of Stramonium.

These, while at first flat and inoperative, soon become bulged and crescent-shaped. This mode of development is seen in *Squill*, *Hyacinth*, *Daffodil*, *Sambucus*, *Silene*, etc.

**Second Type.**—After the cutting off of the stomal mother-cell there are cut off on either side portions of neighboring epidermal cells which form subsidiary cells to the stoma. This condition is seen in *Gramineæ*, *Cyperaceæ*, *Juncaceæ*, in various species of *Aloe*, *Musa* and *Proteaceæ*.

**Third Type.**—Instead of two parallel subsidiary cells, four are cut off, as in *Heliconia*, in species of *Tradescantia*, *Araucaria*, or four to five, as in *Ficus elastica*, or four to five or more, as in the *Coniferæ* and *Cycads*.

**Fourth Type.**—Instead of only four subsidiary cells, each of these again subdivides by parallel walls, more rarely by radial walls, into eight radiating subsidiary cells, as in *Maranta bicolor*, *Pothos argyræa*, some of *Proteaceæ*, etc.

**Fifth Type.**—The “stomal mother-cell” divides once or several times before becoming the true mother-cell of the stoma. As a result of the divisions there are also formed one or more subsidiary cells. This mode of development is seen in the *Labiataæ*, *Papilionaceæ*, *Cruciferæ*, *Solanaceæ*, *Crassulaceæ*, *Cactaceæ*, and *Begoniaceæ*, also in a number of ferns.

**Histologic Differences between Leaves of Dicotyledons and Monocotyledons.**—The following may be cited as broad comparative histologic differences between Dicotyl and Monocotyl leaves:

*Dicotyl Leaves*

*Monocotyl Leaves*

- |  |   |
|--|---|
| 1. Epidermal cells usually iso-diametric or sinuous.   | 1. Epidermal cells usually elongate and equilateral.  |
| 2. The stomata are on the whole more numerous but smaller.   | 2. Stomata larger.  |
| 3. Non-glandular and glandular hairs frequent, or upper but more frequent on lower surface, or both.                           | 3. Hairs rare in Monocotyls.  |
| 4. Leaf glands which excrete varied products are rather abundant.  | 4. Leaf glands rare and only seen as a rule on the sepals.  |
| 5. Water stomata over the upper surface, more rarely over the lower surface, are frequent, especially along margins of leaves. | 5. Water stomata absent or very rare. Present in some <i>Araceæ</i> .   |
| 6. Palisade and spongy parenchyma in dicotyledons are more distinct and palisade parenchyma is denser.                         | 6. Palisade and spongy parenchyma are less distinct and dense.  |
| 7. The vascular bundles, in their intrinsic elements, are more indurated but the accessory fibrous sheath is feebly developed. | 7. The vascular bundles, in their intrinsic elements, are less indurated. The fibrous sheath is strongly developed. |
| 8. A greater variety of accessory products of assimilation are developed.  | 8. A comparatively small variety of accessory products of assimilation are developed.                               |

## INFLORESCENCE

**Inflorescence or Anthotaxy.**—A typical flower consists of four whorls of leaves modified for the purpose of reproduction, and compactly placed on a stem. The terms Inflorescence and Anthotaxy are applied to the arrangement of the flowers and their position on the stem, both of which are governed by the same law which determines the arrangement of leaves. For this reason flower buds are always either terminal or axillary. In either case the bud may develop a solitary flower or a compound inflorescence consisting of several flowers.

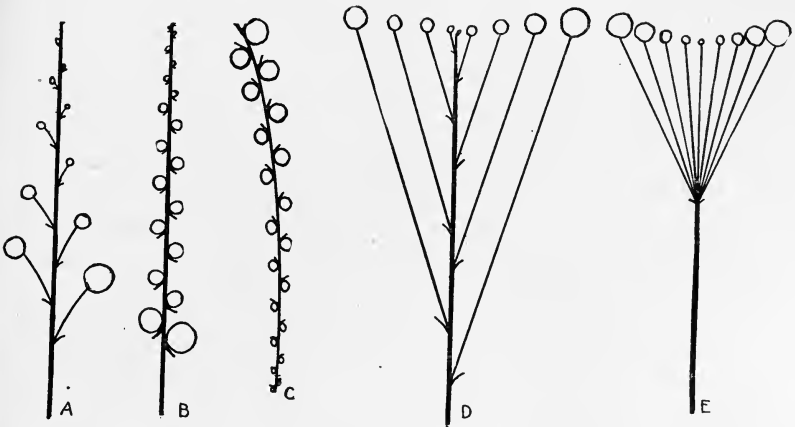

FIG. 90.—Types of indeterminate inflorescence. A, A raceme; B, a spike; C, a catkin; D, a corymb; E, an umbel. The flowers are represented by circles; the age of the flower is indicated by the size. (From Hamaker.)

*Determinate, cymose, descending, or centrifugal* inflorescence is that form in which the flower bud is terminal, and thus determines or completes the growth of the stem. Example: *Ricinus communis*.

*Indeterminate, ascending, or centripetal* inflorescence is that form in which the flower buds are axillary, while the terminal bud continues to develop and increase the growth of the stem indefinitely. Example: the Geranium.

*Mixed inflorescence* is a combination of the other two forms. Example: Horse Chestnut.

The flower stalk is known as the *peduncle*, and its prolongation the *rachis*, or axis of the inflorescence.

The flower stalk of a single flower of an inflorescence is called a *pedicel*. When borne without such support the flower is *sessile*.

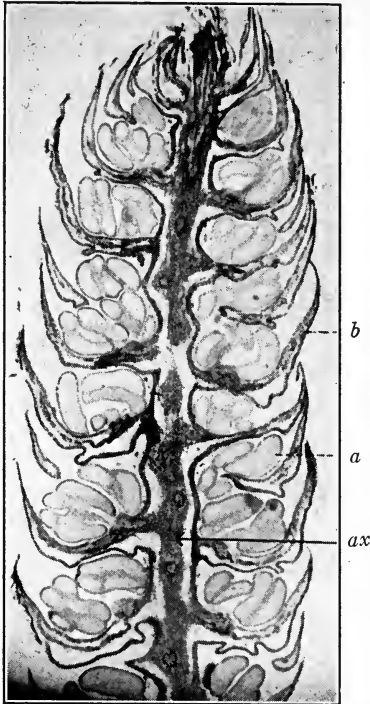

FIG. 91.—Photomicrograph of longitudinal section through a staminate catkin of *Comptonia asplenifolia*  $\times 10$ , showing catkin axis (*ax*), anther-lobe (*a*), and bract (*b*).

A peduncle rising from the ground is called a *scape*, previously mentioned under the subject of stems.

The modified leaves found on peduncles are termed *bracts*. These vary much the same as leaf forms, are described in a similar manner, and may be either green or colored. When collected in a whorl at the base of the peduncle they form an *involucre*, the parts of which are sometimes imbricated or overlapping, like shingles. This is generally green, but sometimes petaloid, as in the Dogwood. The modified leaves found on pedicels are called *bracteolar leaves*.

The *Spathe* is a large bract enveloping the inflorescence and often colored, as in the Calla, or membranous, as in the Daffodil.

**Indeterminate Inflorescences.**—In the indeterminate or axillary anthotaxy, either

flowers are produced from base to apex, those blossoming first which are lowest down on the rachis or from margin to center. The principal forms of this type are:

*Solitary Indeterminate.*—The simplest form of inflorescence in which a single flower springs from the axil of a leaf. A number of



these are generally developed on the same stem. Example: Periwinkle.

*Raceme*, or simple flower-cluster in which the flowers on pedicels of nearly equal length are arranged along an axis. Examples: *Convallaria*, *Cimicifuga*, and Currant.

*Corymb*, a short, broad cluster, differing from the raceme mainly in its shorter axis and longer lower pedicels, which give the cluster a flat appearance by bringing the individual florets to nearly the same level. Example: Cherry.

*Umbel*, which resembles the raceme, but has a very short axis, and the nearly equal pedicels radiate from it like the rays of an umbrella. Many examples of this mode of inflorescence are seen in the family *Umbelliferae*, as indicated by the name, including Anise, Fennel and other drug-yielding official plants.

A *Spike* is a cluster of flowers, sessile or nearly so, borne on an elongated axis. The Mullein and common Plantain afford good illustrations.

The *Catkin* or *Ament* resembles the *Spike*, but differs in that it has scaly instead of herbaceous bracts, as the staminate flowers of the Oak, Hazel, Willow, *Comptonia*, etc.

The *Head* or *Capitulum* is like a spike, except that it has the rachis shortened, so as to form a compact cluster of sessile flowers, as in the Dandelion, Marigold, Clover, and Burdock.

The *Strobile* is a compact flower cluster with large scales concealing the flowers, as the inflorescence of the Hop.

The *Spadix* is a thick, fleshy rachis with flowers closely sessile or embedded on it, usually with a spathe or sheathing bract. Example: *Calla*, *Acorus Calamus*, *Arum triphyllum*.

The compound raceme, particularly if irregularly compounded, is called a *panicle*. Ex. *Hagenia abyssinica*.

**Determinate Inflorescences.**—*Determinate Anthotaxy* is one in which the first flower that opens is the terminal one on the axis, the other appearing in succession from apex to base or from center to margin. The principal varieties are:

The *Solitary Determinate*, in which there is a single flower borne on the scape, as in the *Anemone*, or Windflower, and *Hydrastis*.

The *Cyme*, a flower cluster resembling a corymb, except that the

buds develop from center to circumference. Example: Elder. If the cyme be rounded, as in the Snowball, it is a globose cyme.

A *Scorpioid Cyme* imitates a raceme, having the flowers pedicelled and arranged along alternate sides of a lengthened axis.

A *Glomerule* is a cymose inflorescence of any sort which is condensed into a head, as the so-called head of *Cornus florida*.

A *Verticillaster* is a compact, cymose flower cluster which resembles a whorl, but really consists of two glomerules situated in the axils of opposite leaves. Clusters of this kind are seen in Catnip, Horehound, Peppermint and other plants of the *Labiatae*.

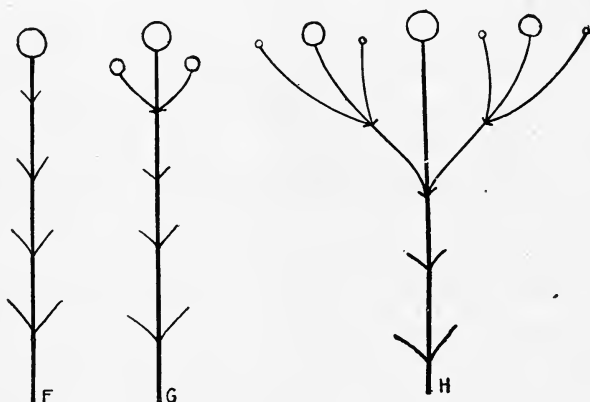

FIG. 92.—Cymose inflorescences. F, A terminal flower; G, a simple cyme; H, a compound cyme. (From Hamaker.)

The raceme, corymb, umbel, etc., are frequently compounded. The compound raceme, or raceme with branched pedicels, is called a panicle. Examples: Yucca and paniculate inflorescence of the Oat.

A *Thyrus* is a compact panicle, of a pyramidal or oblong shape. Examples: Lilac, Grape and *Rhus glabra*.

A *Mixed Anthotaxy* is one, in which the determinate and indeterminate plans are combined, and illustrations of this are of frequent occurrence.

The order of flower development is termed ascending when, as in the raceme, the blossoms open first at the lower point on the axis and continue to the apex. Examples: White Lily, and many other

plants of the same family. In the cyme the development is centrifugal, the central florets opening first, while in the corymb it is centripetal, or from margin to center.

### PREFLORATION

**Prefloration.**—By prefloration is meant the arrangement of the floral envelopes in the bud. It is to the flower bud what vernation is to the leaf bud, the same descriptive terms being largely employed, as convolute, involute, revolute, plicate, imbricate, etc.

In addition to those already defined, the following are important.

*Valvate Prefloration*, in which the margins meet but do not overlap. Of this variety the induplicate has its two margins rolled inward as in Clematis. In the reduplicate they are turned outward, as the sepals of Althaea.

*Vexillary*, the variety shown in the corolla of the Pea, where the two lower petals are overlapped by two lateral ones, and the four in turn overlapped by the larger upper ones.

*Contorted*, where one margin is invariably exterior and the other interior, giving the bud a twisted appearance, as in the Oleander and Phlox.

### THE FLOWER

The flower is a shoot which has undergone a series of changes so as to serve as a means for the propagation of the individual.

A *Typical or Complete Flower* possesses four whorls of floral leaves arranged upon a more or less shortened stem axis called a *receptacle*, *torus* or *thalamus*. These whorls passing from periphery toward the center are: *calyx*, composed of parts called sepals; *corolla*, composed of parts termed petals; *andræcium*, composed of parts called stamens or microsporopylls; and *gynæcium*, composed of one or more parts termed carpels or megasporophylls.

The stamens and carpels constitute the *essential* organs, and a flower is said to be *Perfect* when these are present and functional.

A *Hermaphrodite* flower is one which possesses both stamens and carpels which may or may not be functionally active. In some cases the stamens may alone be functional while in others the carpels only may function.

A *Regular Flower* possesses parts of each whorl of the same shape and size, as the flower of *Veratrum*.

It is *Symmetrical* when the parts of each whorl are of the same number, or multiples of the same number.

An *Imperfect Flower* shows one set of *essential* organs wanting.

When either petals or sepals, or both, are present in more than the usual number, the flower is said to be "*double*," as the cultivated

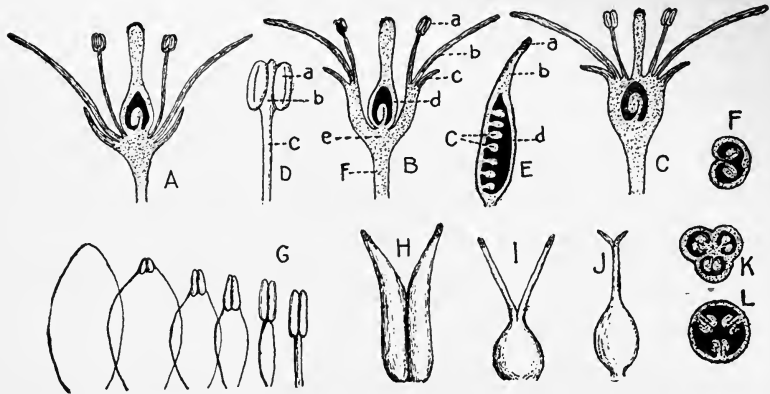

FIG. 93.—Diagrams of floral structures. A, Shows the relations of the floral parts in a hypogynous flower; B, the same in a perigynous flower; C, the same in an epigynous flower; D, a stamen; E, a simple pistil in longitudinal section; F, the same in cross-section; G, transitional forms between true petals (left) and true stamens (right); H, slight union of two carpels to form a compound pistil; I and J, union of carpels more complete; K and L, cross-sections of compound pistils, of three carpels. In B: a, stamen; b, petal; c, sepal; d, pistil; e, receptacle; f, pedicel. In D: a, anther cell; b, connective; c, filament. In E: a, stigma; b, style; c, ovules; d, ovary. (From Hamaker.)

Rose and Carnation. The doubling of flowers is brought about through cultivation and is due either to the transformation of stamens (as in cases cited), and occasionally of carpels into petals, to a division of the petals, or to the formation of a new series of petals.

If the pistils are present and stamens wanting, the flower is called *pistillate*, or female; if it possesses stamens but no pistil, it is described as *staminate*, or male; if both are absent, *neutral*, as marginal flowers of *Viburnum*. Some plants, as the *Begonias* and *Castor oil*, bear both staminate and pistillate flowers, and are called *Monœcious*.

When the staminate and pistillate flowers are borne on different plants of the same species, they are termed *Diœious*, as the Sassafras and Willow. When staminate, pistillate and hermaphrodite flowers are all borne on one plant, as on the Maple trees, they are *polygamous*.

**Connation and Adnation.**—In the development of the flowers of primitive species of flowering plants, the parts of each whorl are disjoined or separate from each other. In many higher types, however, the parts of the same whorl frequently become partly or completely united laterally. This condition is termed *connation*, *coalescence*, *cohesion* or *syngensis*. Illustrations of this may be seen in *Belladonna*, *Stramonium* and *Uva Ursi* flowers, where the petals have joined laterally to form gamopetalous corollas. When the one or more parts of different whorls are united, as of stamens with petals (*Rhammus*) or stamens with carpels (*Apocynum*) the union is called *adnation* or *adhesion*.

**The Receptacle.**—The *Receptacle*, *Torus* or *Thalamus* is a more or less shortened axis (branch) which bears the floral leaves. It is usually flat or convex, but may be conical and fleshy as in the Strawberry, concave as in the Rose and Fig or show a disc-like modification as in the Orange. The internodes of the receptacle in many species lengthen and separate various whorls. When the lengthening of the internode occurs between calyx and corolla, as in *Lychnis*, the structure resulting is called an *anthophore*; if between corolla and androœcium as in *Passiflora*, a *gonophore*; if between androœcium and gynœcium as in *Geum*, a *gynophore*. If the flowers of the *Umbelliferae* the receptacle elongates between the carpels producing the structure called a *carpopfore*.

**The Perigone.**—The perigone or perianth is the floral envelope consisting of calyx and corolla (when present).

When both whorls, *i.e.*, calyx and corolla, are present the flower is said to be *dichlamydeous*; if only calyx is present, *monochlamydeous*.

**The Calyx.**—The Calyx is the outer whorl of modified leaves. Its parts are called Sepals, and may be distinct (Chorisepalous, from a Greek word meaning disjoined) or more or less united (Gamosepalous). They are usually green—foliaceous or leaf-like—but may be brilliantly colored, hence the term petaloid (like the petals) is applied. Examples: Tulip, Larkspur, Columbine and Aconite.

In a *gamosepalous calyx*, when the union of sepals is incomplete, the united portion is called the *tube*, the free portion, the *limb*, the orifice of the tube, the *throat*.

In form the calyx may be regular or irregular; regular, if its parts are evenly developed, and irregular if its parts differ in size and shape. The more common forms are tubular, resembling a tube; rotate, or wheel-shape; campanulate, or bell-shaped; urceolate or urn-shape; hypocrateriform, or salver-shape; bilabiate, or two-lipped; corresponding to the different forms of corolla, under which examples illustrating each will be given.

The calyx usually remains after the corolla and stamens have fallen, sometimes even until the fruit matures—in either case it is said to be persistent. If it falls with the corolla and stamens, it is deciduous, and if when the flower opens, caducous, as in the Poppy and May-apple. It often more or less envelops the ovary or base of the pistil, and it is important, in plant analysis, to note the presence or absence of such a condition, which is indicated in a description by the terms inferior, or non-adherent (hypogynous), when free from the ovary and inserted upon the receptacle beneath it (the most simple and primitive position); half-superior, or half-adherent (perigynous), when it partially envelops the ovary, as in the Cherry; superior or adherent (epigynous), when it completely envelops it, as in the Colocynth, etc.

**Sepaline Spurs.**—Occasionally some or all of the sepals may become pouched and at length spurred as nectar receptacles or as receptacles for other parts that are nectariferous. Thus, in *Cruciferae* we occasionally see a slight pouching of the two lateral sepals. These act as nectar pouches for the nectar secreted by the knobs or girdles surrounding the short lateral stamens. These become deep pouches in *Lunaria* while in others the pouches become elongated spurs. Again, in *Delphinium*, the posterior sepal forms an elongated spur into which pass the two spurred nectariferous petals. In *Aconitum* the same sepal, instead of being spurred, forms an enlarged hood-like body (galea) arching over the flower like a helmet; into this pass the two hammer-shaped nectariferous petals.

**Sepaline Stipules.**—These structures are well developed and easily traceable in the more primitive herbaceous members of the Rose

family. Thus in *Potentilla*, *Fragaria*, *Geum*, etc., in addition to the normal calyx of five sepals, there is a supplementary *epicalyx* also of five parts. The five lobes of the epicalyx may be as large or larger than the sepals or smaller up to the disappearing point. Upon examining a few flowers of *Potentilla* or *Fragaria*, it will be observed that not infrequently one, sometimes two lobes of the epicalyx are bifid, or deeply cleft, or separated completely into two parts. The explanation is that the five sepals, after evolving in the flower bud, form at their bases two lateral swellings or *sepaline stipules*, which, as they grow, fuse in adjacent pairs, one stipule of one sepal joining with the adjacent stipule of another sepal to form five lobes.

**Sepaline Position.**—As already noted the most simple and primitive position for the sepals in relation to the floral parts is *hypogynous*, in which the sepals are inserted directly into the enlarged floral axis (receptacle) below the petals, stamens and carpels. But in the more primitive herbaceous *Rosaceæ*, *Leguminosæ*, etc., the floral axis forms a saucer-like transverse expansion which pushes out the sepals, petals and stamens on its edge. Thus originates the *perigynous* insertion of the sepals. In not a few higher *Rosaceæ*, *Saxifragaceæ*, *Crassulaceæ*, etc., the saucer-like floral axis becomes deepened and contracted into a cup-shaped structure (Cherry, Peach, Almond, Plum, etc.), and on the edge of this cup the sepals as well as the petals and stamens are inserted at different levels. Finally, in the Apple, Pear, Quince, etc., the greatly hollowed-out receptacle assumes a vase-shaped form and closes over the top of the ovary, at the same time lifting the sepals, petals, and stamens above the ovary. Here the sepals are *epigynous*.

**The Corolla.**—The Corolla is the inner floral envelope, usually delicate in texture, and showing more or less brilliant colors and combinations of color. Its parts are called Petals, and when the calyx closely resembles the corolla in structure and coloring they are together called the *Perianth*. The purpose of these envelopes is to protect the reproductive organs within, and also to aid in the fertilization of the flower, as their bright colors, fragrance and saccharine secretions serve to attract pollen-carrying insects.

*Forms of the Corolla and Perianth.*—When the petals are not united with each other, the corolla is said to be *Choripetalous*, *Apo-*

*petalous* or *Polypetalous*. When more or less united, it is *Camopetalous*, often called *Sympetalous*.

When the distinct petals are four in number, and arranged in the form of a cross, the corolla is called *Cruciform*. Example: Mustard and other plants belonging to the family *Cruciferae*.

The *Papilionaceous corolla* is so called because of a fancied resemblance to a butterfly. The irregularity in this form is very striking, and the petals bear special names: the largest one is the *vexillum*, or standard; the two beneath it the *alæ*, or wings; the two anterior, the *carina* or keel. Examples: Locust, Pea, and Clover.

*Orchidaceous* flowers are of peculiar irregularity, combining calyx and corolla. The petal in front of stamen and stigma, which differs from the others in form and secretes nectar, is called the *Labellum*. Examples: *Cypridedium* and other Orchids.

When calyx and corolla each consist of three parts closely resembling each other in form and color, as in the Tulip and Lily, the flower is called *Liliaceous*.

The *Ligulate* or *Strap-shaped corolla* is nearly confined to the family *Compositæ*. It is usually tubular at the base, the remainder resembling a single petal. Examples: Marigold, and Arnica Flowers.

*Labiate*, or *Bilabiate*, having two lips, the upper composed of two petals, the lower one of three. This form of corolla gives the name to the *Labiatae*, while in the family *Leguminosæ* this arrangement is sometimes reversed. The corolla may be either *ringent*, or gaping, as in Sage, or *personate*, when the throat is nearly closed by a projection of the lower lip, as in Snapdragon.

*Rotate*, *Wheel-shaped*, when the tube is short and the divisions of the limb radiate from it like the spokes of a wheel. Example: The Potato blossom.

*Crateriform*, *Saucer-shaped*, like the last, except that the margin is turned upward or cupped. Example: *Kalmia latifolia* (Mt. Laurel).

*Hypocrateriform*, or *Salver-shaped* (more correctly, hypocraterimorphous), when the tube is long and slender, as in Phlox or Trailing Arbutus and abruptly expands into a flat limb. The name is derived from that of the ancient Salver, or hypocraterium with the stem or handle beneath.



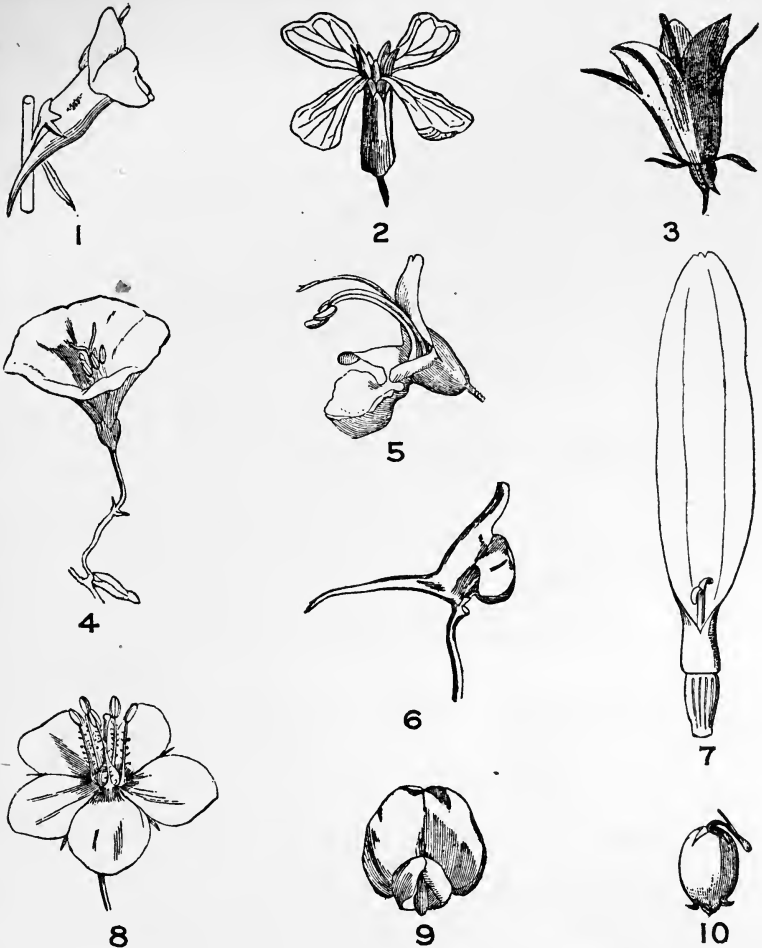

FIG. 94.—Illustrating various forms of the corolla. 1, Personate bilabiate corolla of *Linaria*; 2, cruciform corolla of *Rocket*; 3, campanulate corolla of *Harebell*; 4, infundibuliform corolla of *Bindweed*; 5, ringent bilabiate corolla of *Larkspur*; 6, Ligulate corolla of *Chrysanthemum*; 8, rotate corolla of *Pimpernel*; 9, papilionaceous corolla of *Irish Broom*; 10, urceolate corolla of *Heath*.

When of nearly cylindrical form, the corolla is *Tubular*, as in the Honeysuckle, and Stramonium.

*Funnel-form* (Infundibuliform), such as the corolla of the common Morning Glory, a tube gradually enlarging from the base upward into an expanded border or limb.

*Campanulate*, or *Bell-shaped*, a tube whose length is not more than twice the breadth, and which expands gradually from base to apex. Examples: Canterbury Bell, Harebell.

*Urceolate*, or *Urn-shaped*, when the tube is globose in shape and the limb at right angles to its axis, as in the official Uva Ursi, Chimaphila and Gaultheria.

*Caryophyllaceous*, when the corolla consists of five petals, each with a long slender claw expanding abruptly at its summit into a broad limb. Examples: Carnation and other members of the Pink family.

**The Andrœcium or Stamen System.**—*The andrœcium* is the single or double whorl of male organs situated within or above the corolla. It is composed of *stamens* or *microsporophylls*.

A complete stamen (Fig. 93D) consists of a more or less slender stalk portion called a *filament* and a terminal appendage called the *anther* or *microsoros*. The anther is generally vertically halved by an upgrowth of the filament, called the *connective*, dividing the anther into two *lobes*.

**Number of Stamens.**—When few in number, stamens are said to be *definite*; when very numerous, and not readily counted, they are *indefinite*. The following terms are in common use to express their number:

*Monandrous*, for a flower with but one stamen.

*Diandrous*, with two stamens.

*Triandrous*, with three.

*Tetrandrous*, with four.

*Pentandrous*, having five.

*Hexandrous*, six.

*Polyandrous*, an indefinite number.

The most primitive flowers have numerous stamens, but passing from these to those of more evolved families there occurs a gradual reduction from many to ten, as in *Caryophyllaceæ*, *Leguminosæ* and

some *Aceraceæ*, these being in two circles. In *Malvaceæ*, *Umbelliferæ* and other Apopetalous families as well as many Sympetalæ, the number five is typical. But in *Scrophulariaceæ*, while five are developed and fertile in *Verbascum*, four with a fifth staminode (sterile stamen) are found in the allied genus *Celsia*. In *Pentstemon* there are four didynamous fertile stamens and an equally long staminode. In *Scrophularia* the fifth staminode is reduced to a petaloid flap in the posterior part of the flower. In *Linaria* this exists only as a small knob at the base of the back part of the corolla and there secretes nectar. In most *Scrophulariaceæ* the fifth stamen is entirely absent and the four stamens left are didynamous; but in *Calceolaria* two of these are rudimentary and thread-like, the other two alone being well-developed and fertile. In *Veronica* three stamens are entirely absorbed and two only are left as fertile representatives.

**Insertion of Stamens.**—As to insertion the stamens may be:

*Hypogynous*, when inserted upon the receptacle below the base of the pistil (see Fig. 93A).

*Perigynous*, when inserted on the calyx or corolla above the base of and lateral to the pistil (see Fig. 93B).

*Epigynous*, when inserted above the ovary (see Fig. 93C).

*Gynandrous*, when inserted upon the pistil, as in Orchids and Aristolochia.

**Proportions of the Stamens.**—The stamens may be of equal length; unequal, or of different length.

*Didynamous*, when there are two pairs, one longer than the other.

Example: Snapdragon.

*Tetradynamous*, three pairs, two of the same length, the third shorter. Example: Mustard.

**Connation of Stamens.**—Terms denoting connection between stamens are:

*Monadelphous* (in one brotherhood), coalescence of the filaments into a tube. Example: *Lobelia*.

*Diadelphous* (in two brotherhoods), coalescence into two sets. Example: *Glycyrrhiza*.

*Triadelphous*, with filaments united into three sets. Example: St. John's Wort.

*Polyadelphous*, when there are several sets or branched bundles.  
Example: Orange.

*Syngenesious*, when the anthers cohere. Example: *Compositæ*.

**Color of Stamens.**—In most species the color of these organs is seldom pronounced owing to their delicate structure. It varies from greenish-yellow to yellow to white, through pink, pinkish-red, red, purple, purple-blue to blue. It is yellow, for instance, in *Sassafras*, *Cucumber* and *Golden Club*; greenish-yellow, yellow to red, in *Maples*; yellow-pink to pink and pinkish-red, in some *Mallows*; in *Azalea amena* the filaments are crimson-purple and the anthers, purple-blue; in the genus *Scilla* both filaments and anthers are blue.

**Gross Structure and Histology of the Filament.**—The filament may be cylindrical as in the *Rose*, awl-shaped as in *Tulip*, flat and with a dilated base as in the *Harebell*, three-toothed as in *Garlic*, appendiculate, when it bears an appendage as in *Chatostoma*, *Alyssum*, etc. The filament is covered with a protective epidermis containing stomata. Beneath this is a soft, loose cellular tissue, the mesophyll, and in the center a small vascular bundle, the pathway of food from the floral axis to the anther. In some cases the single bundle may split into two or three bundle parts.

**Gross Structure and Histology of the Anther.**—Each staminal leaf (microsporophyll) bears a special development or appendage as a rule on its extremity which is the *anther* or *microsorius*. This consists, fundamentally, of a median prolongation of the filament equal to the connective or placenta. This develops on either side a quantity of indusial tissue that grows out to form a covering substance that protects and carries two microsporangia on either side. An anther therefore consists of a median *connective* or placenta, producing on either side two *anther lobes* or indusial expansions. Each anther lobe encloses two pollen sacs or *microsporangia*, which, in some cases, remain distinct up to the dehiscence (splitting open) of the anther. Thus in *Butomus*, the anthers show four pollen chambers up to the time of dehiscence. Again in various species of *Lauraceæ*, the anthers remain four lobed and dehisce by four recurved lids. But in the great majority of Angiosperms each pair of pollen sacs fuse before dehiscence, owing to the breaking down of the partition between them, and so, at that time, show two-celled anthers. Still more

rarely the anthers may be two-celled in their young state and by the breaking down of the partition become one-celled, e.g., *Malvaceæ*.

Externally the mature anther is bounded by an *exothecium* or epidermis, often swollen, where lines of dehiscence occur, which may develop stomata, also hairs. Within it is a combined layer or set of one to often two or three, sometimes five or six cell layers (Agave, etc.) of indusial and sporangial cells, the *endothecium*. The outermost one to three layers of this become spirally, annularly or stellately thickened to form the elastic tissue of the anther, which, by pressure against the delicate epidermis or exothecium, causes ultimate rupture of the anther wall. Within the innermost endothelial layer, bounding each sporangium, is the *tapetum*, a single-celled layer. This, near the time of dehiscence, undergoes breaking down or absorption by developing *pollen* or microspore cells. Filling the cavities of the four sporangia are the mature pollen grains. The connective shows in or near its center a vascular bundle with xylem uppermost and phloem downward, surrounded by thin-walled cellular tissue, from which the indusial and sporangial substance has matured by extension.

**Anther Dehiscence.**—This is the breaking open of the anther to discharge the pollen.

When fully ripe the dividing partition between each pair of sporangia usually becomes thinned, flattened and ultimately breaks down, while the elastic and resistant endothecium, steadily pushing against the more delicate and now shrinking exothecium causes rupture where endothecium is absent, namely along opposite lines of the anther wall. Thus arises a line of anther dehiscence called *longitudinal anther dehiscence* on either side of the anther sacs. In the division *Solanææ* of the family *Solanaceæ* which includes Belladonna, in some of the *Ericaceæ* as *Rhododendron* and *Azalea*, etc., the anthers dehisce by small apical pores from which the pollen is shed. This kind of dehiscence is called *apical porous dehiscence*. Again, in *Lauraceæ* and *Berberidaceæ*, the anthers dehisce by recurved valves. This is called *valvular dehiscence*.

Moreover, in *Malvaceæ* the originally longitudinal anther is divided internally by a partition. It gradually swings on the filament so that eventually the anther is transverse and the partition becomes

absorbed, thus becoming a one-celled anther with *transverse dehiscence* in its mature state.

**Development of the Anther.**—Each stamen originates as a knob-like swelling from the receptacle between the petals and carpels. This swelling represents mainly future soral (anther) tissue. The filament develops later. When such a young sorus or anther is cut

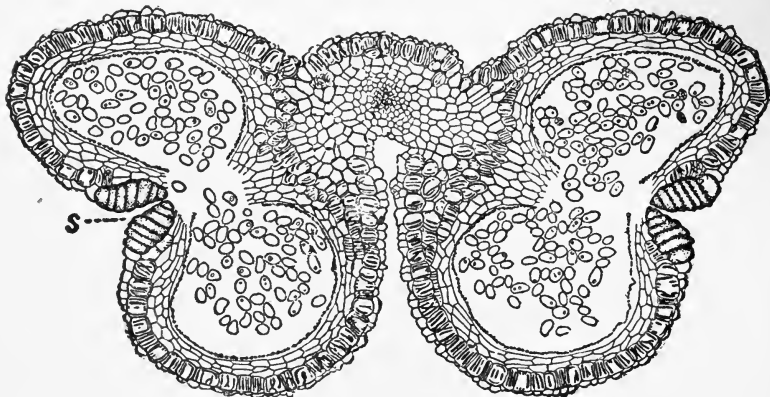

FIG. 95.—Cross-section of a mature lily anther. The pairs of pollen chambers unite to form two pollen sacs, filled with pollen grains; s, modified epidermal cells at line of splitting. (From a *Text-book of Botany* by Coulter, Barnes, and Cowles. Copyright by the American Book Company, Publishers.)

across and examined microscopically, it shows a mass of nearly similar cellular tissue in which the first observable changes are the following:

The surface dermatogen cells become somewhat flattened and regular to form the future epidermis or exothecium of the anther. About the same time some cells, by more rapid division in the middle of the anther substance, give rise to the elements of the vascular bundle in the connective. Then, along four longitudinal tracts, rows of cells remain undivided or only divide slowly as they increase in size and around them cells divide and redivide to form the future endothelial and covering tissue to the four sporangia. Next, the four sporangial tracts of undivided cells cut off from their outer surfaces a layer of enveloping cells, the *tapetum*. This consists of richly protoplasmic cells that form a covering to the *spore mother-cells*

within. Each spore mother-cell undergoes division and redivision into four spore daughter-cells, at the same time that reduction in the chromatin substance takes place in these cells. Thus originate *tetrads* (groups of four) of *spore daughter-cells* inside spore mother-cell wall. These continue to enlarge, press against the mother-cell wall which becomes converted into mucilage and each of the tetrad cells becomes in time a mature *microspore* or *pollen grain*.

During this time the entire anther is growing in size, the cells of the endothecium in one or more layers becomes thickened by lignin deposits to form a mechanical *endothecium*; the *tapetum* gradually breaks down and appears only, at length, as an irregular layer around the maturing pollen cells. When the anther is finally ripe the partition between each pair of microsporangia becomes narrowed, flattened and ruptured and thus numerous microspores or pollen grains fill two cavities, one on either side of the connective. The microspores or pollen grains at first show only a thin clear cellulose layer, but from this, by a differentiation of the exterior film, the *exospore* layer becomes cut off. This becomes cuticular. The cellulose inner layer (*endospore*), remains unaltered. In the development of the exospore, one to several deficiencies are usually left in it through which the endospore may protrude later as the rudiment of the pollen tube.

*Attachment of Anther*.—The attachment of the anther to the filament may be in one of several ways, as follows:

*Innate*, attached at its base to the apex of the filament.

*Adnate*, adherent throughout its length.

*Versatile*, when the anther is attached near its center to the top of the filament, so that it swings freely. The adnate and versatile are *introrse* when they face inward, *extrorse* when they face outward.

**Pollen**.—The pollen grains or microspores vary in form for different species and varieties and while they are averagely constant for these, nevertheless many exceptions have been recorded. The following are some of the commoner forms:

*Four Spore Daughter-cells*, hanging together as in the Cat Tail (*Typha*) forming a pollen grain.

*Elongated*, simple pollen grains as in *Zostera*.

*Dumb-bell-shaped*, as the pollen of the Pines.

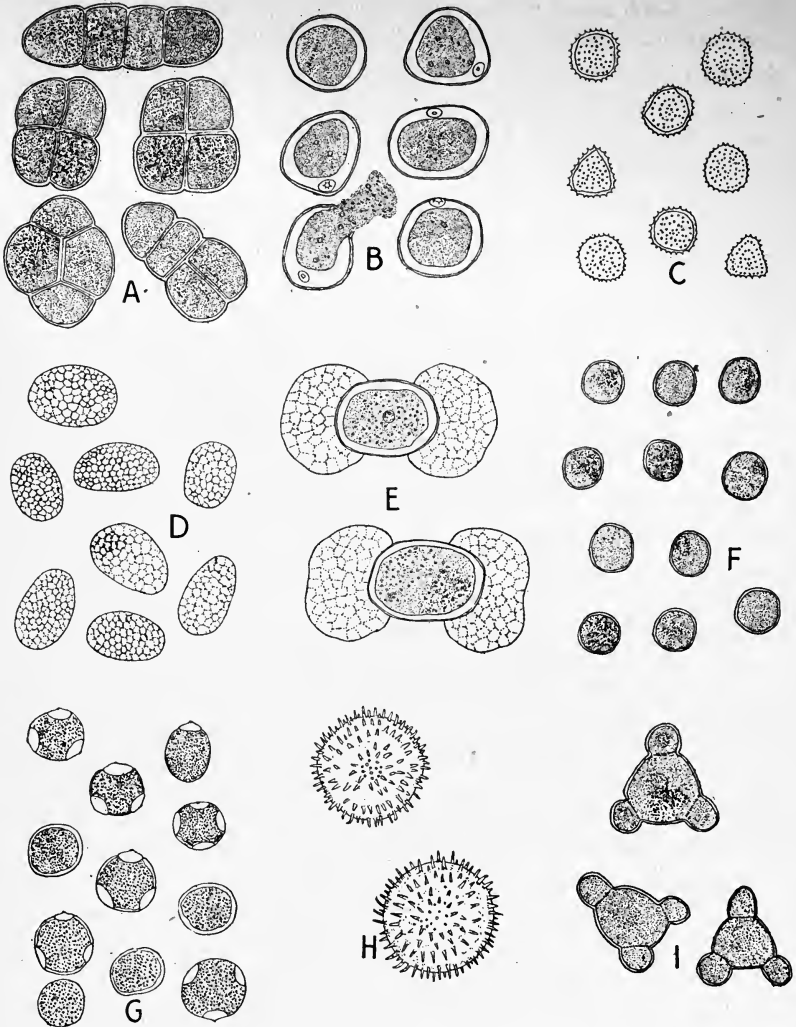

FIG. 96.—Various forms of pollen grains. Pollen from *Typha latifolia* (A), *Zea mays* (B), *Ambrosia elatior* (C), *Lilium philadelphicum* (D), *Pinus* (E), *Ranunculus bulbosus* (F), *Carpinus caroliniana* (G), *Althæa rosea* (H), *Oenothera biennis*, (I). All highly magnified. Drawing by Hogstad.



*Triangular*, as in the *Œnotheras*.

*Echinate*, as in the *Malvaceæ*.

*Spherical*, as in *Geranium*, Cinnamon and Sassafras.

*Lens-shaped*, as in the Lily.

*Spinose*, as in the *Compositæ*.

*Barrel-shaped*, as in *Polygala*.

Under the microscope the immature pollen grain generally consists of two membranes, an outer firmer one called the *exospore*, which may be variously marked and which possesses deficiencies in the form of "pores" or "clefts," and an inner delicate cellulose membrane called the *endospore*, which surrounds a protoplasmic interior in which are imbedded a nucleus, oil droplets and frequently starch or protein.

*Pollinia*.—These are agglutinated pollen masses which are common to the *Orchidaceæ* and *Asclepiadaceæ*.

The pollen of many plants, notably certain species of *Compositæ*, *Gramineæ* and *Rosaceæ*, has been shown to be responsible for "Hay Fever." At the present time serums, extracts and vaccines are manufactured from pollen to be used in the treatment of this disease.

**The Gynœcium or Pistil System.**—This is the female system of organs of flowering plants. It may consist of one or more modified leaves called carpels. Each *carpel* or *megasporophyll* is a female organ of reproduction. In the Spruce, Pine, etc., it consists of an open leaf or scale which bears but does not enclose the *ovules*. In angiosperms it forms a closed sac which envelops and protects the *ovules*, and when complete is composed of three parts, the ovary or hollow portion at the base enclosing the *ovules* or rudimentary seeds, the *stigma* or apical portion which receives the pollen grains, and the *style*, or connective which unites these two. The last is non-essential and when wanting the stigma is called sessile. The carpel clearly shows its relations to the leaf, though greatly changed in form. The lower portion of a leaf, when folded lengthwise with the margins incurved, represents the *ovary*; the infolded surface upon which the *ovules* are borne is the placenta, a prolongation of the tip of the leaf, the stigma, and the narrow intermediate portion, the style. *A leaf thus transformed into an ovule-bearing organ is called a carpel.* The carpels of the Columbine and Pea are made up of

single carpels. In the latter the young peas occupy a double row along one of the sutures (seams) of the pod. This portion corresponds to the infolded edge of the leaf, and the pod splits open along this line, called the ventral suture.

Dehiscence, or the natural opening of the carpel to let free the contained seeds, takes place also along the line which corresponds to the mid-rib of the leaf, the dorsal suture.

The gynœcium or Pistil may consist of a number of separate carpels, as in the buttercup or *Nymphaea* flowers, when it is said to be *apocarpous*; or the carpels composing it may be united together to form a single structure, as in the flowers of Belladonna and Orange, when it is called *syncarpous*.

If the pistil is composed of one carpel, it is called *monocarpellary*; if two carpels enter into its formation, it is said to be *dicarpellary*; if three; *tricarpellary*; if many, *polycarpellary*.

*Compound Pistils* are composed of carpels which have united to form them, and therefore their ovaries will usually have just as many cells (locules) as carpels. When each simple ovary has its placenta, or seed-bearing tissue, at the inner angle, the resulting compound ovary has as many axile or central placentaë as there are carpels, but all more or less consolidated into one. The partitions are called dissepiments and form part of the walls of the ovary. If, however, the carpels are joined by their edges, like the petals of a gamopetalous corolla, there will be but one cell, and the placenta will be parietal, or on the wall of the compound ovary.

The *ovules* or megasori are transformed buds, destined to become seeds in the mature fruit. Their number varies from one to hundreds. In position, they are erect, growing upward from the base of the ovary, as in the Compositæ; ascending, turning upward from the side of the ovary or cell; pendulous, like the last except that they turn downward; horizontal, when directed straight outward; suspended, hanging perpendicularly from the top of the ovary.

In Gymnosperms the ovules are naked; in Angiosperms they are enclosed in a seed vessel.

A complete angiospermous seed ovule which has not undergone maturation consists of a *nucellus* or body; two coats, the outer and inner *integuments*; and a *funiculus*, or stalk. Within the nucellus

is found the *embryo sac* or *megaspore* containing protoplasm and a nucleus. (See Fig. 97A).

The coats do not completely envelop the nucellus, but an opening at the apex, called the *foramen* or *micropyle* admits the pollen tube. The vascular plexus near the point where the coats are attached to each other and to the nucellus is called the *chalaza*. The *hilum* marks the point where the funiculus is joined to the ovule, and if attached to the ovule through a part of its length, the adherent portion is called the *raphe*. The shape of the ovule may be *orthotropous*, or straight; *campylotropous*, bent or curved; *amphitropous*, partly inverted; and *anatropous*, inverted. The last two forms are most common. A campylotropous ovule is one whose body is bent so that the hilum and micropyle are approximated.

*The Placenta*.—The placenta is the nutritive tissue connecting the ovules with the wall of the ovary. The various types of placenta arrangement (placentation) are grouped according to their relative complexity as follows: (1) Basilar, (2) Sutural, (3) Parietal, (4) Central, (5) Free Central.

Basilar placentation is well illustrated in the *Polygonaceæ* (Smart Weed, Rhubarb, etc.) in *Piper* and *Juglans*. Here, at the apex of the axis and in the center of the ovarian base, arises a single ovule from a small area of placental tissue.

Sutural placentation is seen in the *Leguminosæ* (Pea, Bean, etc.). Here each carpel has prolonged along its fused edges two cord-like placental twigs, from which start the funiculi or ovule stalks.

Parietal placentation is seen in *Gloxinia*, *Gesneria*, *Papaver*, etc. Here we find two or more carpels joined and placental tissue running up along edges of the fused carpels bearing the ovules.

Central or axile placentation is seen in *Campanulaceæ* (Lobelia), where the two, three, or more carpels have folded inward until they meet in the center and in the process have carried the originally parietal placenta with them. This then may form a central swelling bearing the ovules over the surface.

Free Central placentation occurs perfectly in the *Primulaceæ*, *Plantaginaceæ* and a few other families. In this the carpels simply cover over or roof in a central placental pillar around which the ovules are scattered.

**Style.**—The style is the portion of the carpel which connects the stigma with the ovary. It is usually thread-like but may also be considerably thickened. It frequently divides into branches in its upper part. These are called *style arms*. As many style arms as carpels may be present. In the one-carpelled pistil of some *Leguminosæ*, the usually bent-up style is the tapered prolongation of a single flower. Again, in the apocarpous carpels of many flowers of the *Ranunculaceæ*, each carpel bears a short to long stylar prolongation. When the carpels, however, are syncarpous the common styles tend to become more or less fused but usually show lobes, clefts or style arms at their extremities that indicate the number of carpels in each case which form the gynoecium.

In some plants remarkable variations from the typical stylar development may occur. Thus, in *Viola*, the end of the style is a swollen knob on the under surface of which is a concave stigma with a flap or peg. In the genus *Canna* the style is an elongate blade-like flattened body with a sub-terminal stigma. In forms of the *Campanulaceæ* the style is closely covered with so-called collecting hairs. On these the anthers deposit their pollen at an early period before the flowers have opened. Later, when the flowers open, insects remove the pollen after which the collecting hairs wither. The stigmas then curl apart to expose their viscid stigmatic hairs. In this instance there are two distinct and at separate times functioning hairs on the stylar prolongation, viz.: (a) *collecting stylar hairs*, functioning for pollen collection and distribution; and (b) *stigmatic hairs* for pollen reception from another flower. In *Vinca* the style swells near its extremity into a broad circular stigma and then is prolonged into a short *column* bearing a tuft of hairs that prevents the entrance of insect thieves into the flower. In the genus *Iris* the common style breaks up at the insertion of the perianth into three wide petaloid style arms. Each of these bifurcates at its extremity. On the lower or outer face of this is a transverse flap that bears the stigmatic papillæ. In *Physostigma* the style enlarges at its extremity into a flap-like swelling which bears a narrow stigmatic surface. Finally in *Sarracenia* the single style of the five-carpelled pistil enlarges above into a huge umbrella-like portion with five radiating ribs. At the extremity of each bifid end of each rib is a minute peg-like stigmatic surface.

**The Stigma.**—This is usually a viscid papillose surface of greater or less expanse functioning for pollen reception. In wind-pollinated flowers such as the grasses, the stigmas are the numerous feathery hairs which cover the ends of the styles and intended to catch flying pollen grains. In animal-pollinated flowers, the stigmas are usually small restricted knobs, lines or depressions. The stigmatic papillæ vary in size in different plants and even may vary on different individuals of the same species. Thus in the long styles of *Primula*, the stigmatic papillæ are elongated columnar hair-like structures, whereas in the short styles of short-styled flowers the papillæ are small knob-like cellular swellings.

### POLLINATION

Pollination is the transfer of pollen from anther to stigma and the consequent germination thereon. It is a necessary step to fertilization.

When the pollen is transferred to the stigma of its own flower the process is called *Close* or *Self-pollination*; if to a stigma of another flower, *Cross-pollination*. If fertilization follows, these processes are termed respectively, *Close* or *Self-fertilization* and *Cross-fertilization*. Close-fertilization means in time ruination to the race and happily is prevented in many cases by (a) the stamens and pistils standing in extraordinary relation to each other, (b) by the anthers and pistils maturing at different times, (c) by the pollen in many cases germinating better on the stigma of another flower than its own.

The agents which are responsible for cross-pollination are the wind, insects, water currents, small animals, and man.

*Wind-pollinated*, flowering plants are called *Anemophilous*; their pollen is dry and powdery, flowers inconspicuous and inodorous, as in the Pines, Wheat, Walnut, Hop, etc.

*Insect-pollinated plants* are called *Entomophilous*. These, being dependent upon the visits of insects for fertilization, possess brilliantly colored corollas, have fragrant odors, and secrete nectar, a sweet liquid very attractive to insects, which are adapted to this work through the possession of a pollen-carrying apparatus. Example: Orchids.

*Plants pollinated through the agency of water currents* are known as *Hydrophilous*. To this class belong such plants as live under water and which produce flowers at or near the surface of the same. Example: *Sparganium*.

*Animal-pollinated plants* are called *Zoöphilous*. Some plants like the *Nasturtium* and *Honeysuckle* are pollinated by humming birds.

Before the pollen grain has been deposited upon the stigma and during its germination thereon, a series of events affecting both the pollen grain and the embryo sac occur which result in the ultimate formation of the male and female gametophytes.

**Maturation of the Pollen Grain and Formation of the Male Gametophyte.**—The substance of the microspore (pollen grain) divides into two cells, the *mother* and *tube cells* of the future male gametophyte. The nucleus of the mother-cell divides to form two sperm nuclei. Within the tube cell is found a tube nucleus embedded in protoplasm. Upon germinating the partition disappears and the thin endospore, carrying within it the protoplasm in which are embedded the tube nucleus and two sperm nuclei, penetrates through a deficiency of the exospore. The contents of the pollen grain at this stage is called the *male gametophyte*.

**Maturation of the Embryo Sac and Formation of the Female Gametophyte.**—The *nucleus* of the megaspore or embryo sac undergoes division until eight *daughter-nuclei* are produced which are separated into the following groups:

(a) Three of these nuclei occupy a position at the apex, the lower nucleus of the group being the egg or ovum, the other two nuclei being the *synergids* or *assisting nuclei*.

(b) At the opposite end of the sac are three nuclei known as the *antipodals* which apparently have no special function.

(c) The two remaining nuclei (*polar nuclei*) form a group lying near the center of the embryo sac which unite to form a single *endosperm* nucleus from which, after fertilization, the endosperm or nourishing material is derived. This stage of the embryo sac constitutes the *female gametophyte*.

**Fertilization in Angiosperms.**—After the pollen grain reaches the stigma, the viscid moisture of the stigma excites the outgrowth of the male gametophyte which bursts through the coats of the pollen

grain forming a pollen tube. The pollen tube, carrying within its walls two sperm nuclei and one tube nucleus, penetrates through the loose cells of the style until it reaches the micropyle of the ovule, then piercing the nucellus, it enters the embryo sac. The tip of the tube breaks and one of the sperm nuclei unites with the egg to form the *öospore*. The *öospore* develops at once into an embryo or plantlet,

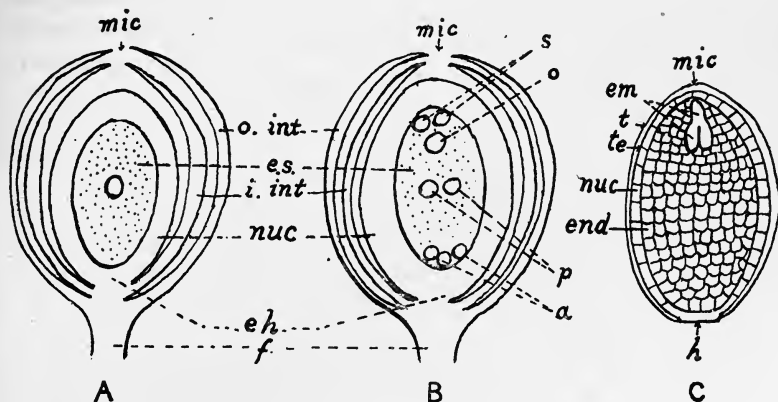

FIG. 97.—A, Immature angiospermous ovule; B, same, after embryo-sac (*e.s.*) has matured to form the female gametophyte; nucellus (*nuc*); outer integument (*o. int*); inner integument (*i. int*); embryo sac (*e.s.*); micropyle (*mic*); chalaza (*ch*); funiculus (*f*); synergids (*s*); ovum (*o*); polar nuclei (*p*); antipodals (*a*); C, fertilized and matured angiospermous ovule (seed). Note that the nucellus (*nuc*) has been pushed out by the encroachment of the embryo sac, in which endosperm has formed by the fusion of the two polar nuclei with the second sperm nucleus from the pollen tube which has later divided to form numerous nuclei scattered about in the protoplasm of the embryo sac and accumulated protoplasm and laid down walls, within which nourishment was stored; embryo (*em*) from fertilized ovum; testa (*t*) from outer integument; tegmen (*te*) from maturation of inner-integument; micropyle (*mic*); hilum or scar (*h*), after funiculus became detached.

which lies passive until the seed undergoes germination. The other sperm nucleus unites with the previously fused polar nuclei to form the endosperm nucleus which soon undergoes rapid division into a large number of nuclei that become scattered about through the protoplasm of the embryo sac. These accumulate protoplasm about them, cells walls are laid down, *endosperm* resulting.

## THE FRUIT

The fruit consists of the matured pistil (carpel or carpels) and contents, or ovarian portion thereof, but may include other organs of the flower which frequently are adnate to and ripen with it. Thus in the Apples, Pears and Quinces, the receptacle becomes thick and succulent, surrounds the carpels during the ripening process and forms the edible portion of these fruits. In Dandelion, Arnica, and many other members of the *Compositæ*, the modified calyx or *pappus* adheres to the ovary during its maturation into the fruit and renders the fruit buoyant. In *Gaultheria* the calyx becomes fleshy, surrounds the ovary, reddens, and forms the edible part of the fruit. In *Physalis* the calyx enlarges considerably and encloses the ovary in an inflated colored bladder. Involucres frequently persist around and mature with the fruits. These may be membranous as in *Anthemis*, *Matricaria* and other *Compositæ*, leathery and prickly as in the Chestnuts, scaly woody cups (cupules) as in the Oaks, or foliaceous cups as in the Filberts. Occasionally, as in the Fig, Osage Orange, Mulberry, etc., the fruit may consist of the ripened flower cluster or inflorescence.

## FRUIT STRUCTURE

The *Pericarp*, or *seed vessel*, is the ripened wall of the ovary, and in general the structure of the fruit wall resembles that of the ovary, but undergoes numerous modifications in the course of development.

The number of cells of the ovary may increase or decrease, the external surface may change from soft and hairy in the flower to hard, and become covered with sharp, stiff prickles, as in the *Datura Stramonium* or Jamestown weed. Transformations in consistence may take place and the texture of the wall of the ovary may become hard and bony as in the Filbert, leathery, as the rind of the Orange, or assume the forms seen in the Gourd, Peach, Grape, etc.

Frequently the pericarp consists for the most part of other elements than the ripened ovarian wall and is then termed a *pseudocarp* or *anthocarp*. The pericarp consists of three layers of different texture, viz.: *epicarp*, *mesocarp* and *endocarp*. The epicarp is the outer layer. The mesocarp the middle, and the endocarp the inner



layer. When the mesocarp is fleshy, as in the Peach, it is called the *sarcocarp*.

When the endocarp within the sarcocarp is hard, forming a shell or stone, this is termed a *putamen*.

**Sutures.**—The *ventral suture* is a line formed by the coherent edges of a carpellary leaf. The *dorsal suture* is the mid-rib of the carpel. *Parietal sutures* are lines or furrows frequently visible on the walls of fruits, formed by the ripening of a compound ovary. They occur between its dorsal sutures and indicate the places of union between adjacent septa or of two parietal placentæ.

**Valves.**—These are the parts into which the mature fruit separates to permit the escape of the seeds. Depending upon the number of these the fruit is said to be *univalved*, *bivalved*, *trivalved*, etc.

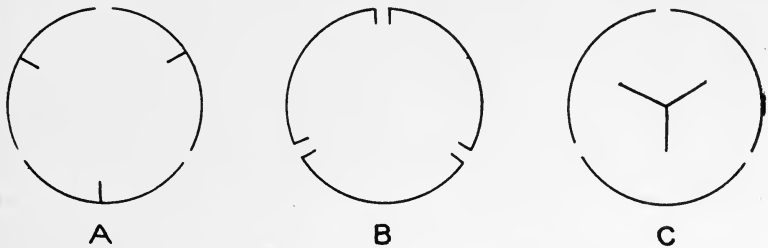

FIG. 98.—Diagrams illustrating three forms of valvular dehiscence. A, Loculicidal dehiscence showing each carpel split along its midrib or dorsal suture, the dissepiments remaining intact; B, septicidal dehiscence, in which splitting took place along the partitions; C, septifragal dehiscence, in which the valves broke away from the partitions.

**Dehiscence.**—This is the opening of the pericarp to allow the seeds to escape.

Fruits are either *Dehiscent* or *Indehiscent* according as they open to discharge their seeds spontaneously when ripe (dehiscent), or decay, thus freeing the seeds, or retain their seeds, the embryo piercing the pericarp in germination (*indehiscent*). Dehiscent fruits open regularly, or normally, when the pericarp splits vertically through the whole or a part of its length, along sutures or lines of coalescence of contiguous carpels. Legumes usually dehisce by both sutures. Irregular or abnormal dehiscence has no reference to normal sutures, as where it is *transverse* or *circumscissile*, extending around the cap-

sule either entirely or forming a hinged lid, as in *Hyoscyamus*, or detached.

*Dehiscence* is called *porous* or *apical* when the seeds escape through pores at the apex, as in the Poppy; *valvular*, when valve-like orifices form in the wall of the capsule. *Valvular dehiscence* is *septicidal*, when the constituent carpels of a pericarp become disjoined, and then open along their ventral suture. Example: *Colchicum*; *loculicidal*, dehiscence into loculi, or cells, in which each component carpel splits down its dorsal suture, and the dissepiments remain intact. Example: *Cardamon*; *septifragal dehiscence*, a breaking away of the valves from the septa or partitions. Example: *Orchids* (Fig. 98).

**Classification of Fruits** (according to structure).—*Simple fruits* result from the ripening of a single pistil in a flower.

*Aggregate fruits* are the product of all the carpel ripenings in one flower, the cluster of carpels being crowded on the ripened receptacle forming one mass, as in the Raspberry, Blackberry, and Strawberry.

*Multiple fruits* are those which are the product of the ripening of a flower cluster instead of a single flower.

Simple and Compound fruits are either Dry or Fleshy. The first may be divided into Dehiscent, those which split open when ripe; and Indehiscent, those which do not.

#### Simple Fruits:

- |           |   |                               |
|-----------|---|-------------------------------|
| Dry       | { | I. Capsular (dehiscing).      |
|           |   | II. Schizocarpic (splitting). |
|           |   | III. Achenial (indehiscent).  |
| Succulent | { | IV. Baccate (berries).        |
|           |   | V. Drupaceous (stone fruits). |

The **capsular** fruits include all of those, whether formed of one or more carpels, which burst open to let their seeds escape.

**Schizocarpic** or splitting fruits are those in which each carpel or each half carpel (in Labiatae) splits asunder from its neighbor and then falls to the ground. The split portion is one-seeded.

**Achenial** fruits are dry, one-celled, one-seeded and indehiscent at the time of final ripening.

**Baccate** fruits are such in which the endocarp always and the mesocarp usually becomes succulent and so the seeds lie in the pulp formed by the endocarp or endocarp and mesocarp combined.

**Drupaceous** fruits are those in which the endocarp is always fibrous or stony in consistence, while the mesocarp is more or less succulent. The endocarp may become cuticularized as in the Apples. The mesocarp may form stone cells lying in the midst of

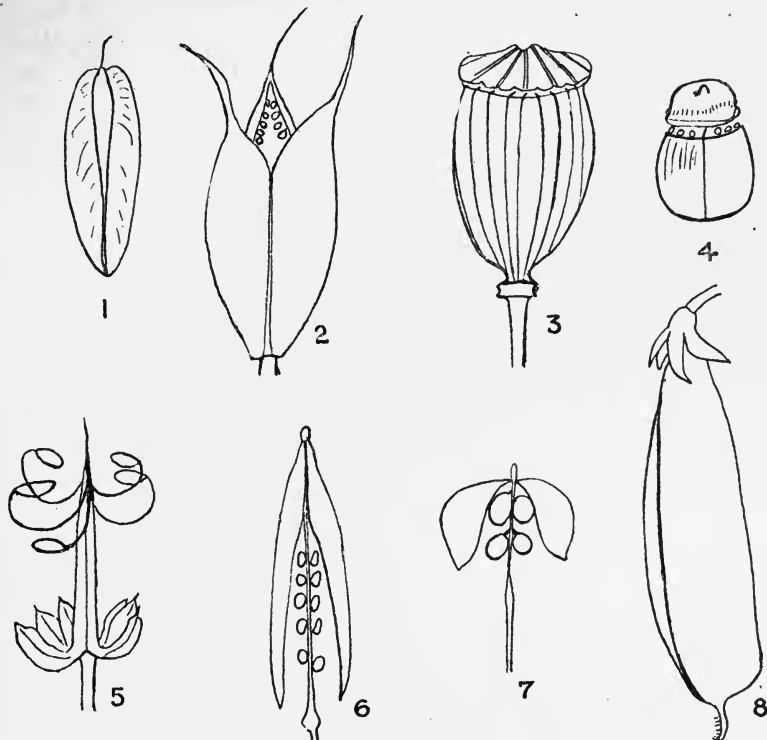

FIG. 99.—Types of capsular fruits. 1, Pod of Aconite; 2, Capsule of Colchicum showing septicial dehiscence; 3, capsule of poppy, having porous dehiscence; 4, pyxis of Henbane; 5, dehiscent regma of Geranium; 6, siliqua of Celandine showing valves opening from below upward; 7, silicule of Cochlearia; 8, egume of Pea.

soft parenchyma cells as in Pears; it may become hardened and thickened by lignin deposits to form fibers as in the Coconut, or it may become swollen and soft-succulent as in Peaches, Cherries, etc.

**I. Capsular Fruits.**—These may be simple, when composed of one carpel as the follicle and legume, or compound, when composed of two or more carpels as the capsule, pyxis, regma, siliqua or silicule

The **Follicle** or pod is a dry, simple capsular fruit formed of a single carpel which dehisces by one suture. This is usually the ventral suture as in *Aconite*, *Staphisagria*, *Larkspur* and some other *Ranunculacæ*, but may be the dorsal suture as in *Magnolia*, Fig. 99 (1).

A **Legume** is a dry simple capsular fruit formed of a single carpel and dehiscent by both ventral and dorsal sutures. Examples: Peas, Beans, etc. The legume is typical of most *Leguminosæ*, Fig. 99 (8).

A **Capsule** is a fruit formed of two or more carpels which dehisce longitudinally or by apical teeth or valves. Examples: *Cardamon*, Poppy, *Iris*, etc., Fig. 99 (2 and 3).

A **Pyxis** or **Pyxidium** is a capsular fruit formed of two or more carpels that dehisce transversely. Examples: *Hyoscyamus*, *Portulaca*. The upper portion forms a lid which fits upon the lower pot-like portion, Fig. 99 (4).

A **Regma** is a capsular fruit of two or more carpels that first splits into separate parts and then each of these dehisces. This type of fruit is typical of *Hura crepitans* (Sandbox), *Pelargonium* and *Geranium*, Fig. 99 (5).

A **Siliqua** is a long slender one or two-celled capsule, often with a spurious membranous septum (when two-celled) and two persistent parietal placentæ, the valves opening from below upward. Examples: *Chelidonium* and Wallflower, Fig. 99 (6).

A **Silicula** is a short siliqua in which the length is never much greater than the breadth. Example: *Cochlearia*. Fig. 99 (7).

II. **Schizocarpic Fruits**.—A **Carcerulus** or **Nutlet** is the typical fruit of the Labiatæ but is also seen in the Borraginacæ. The ovary that has become four-celled at the time of flowering matures into four little pieces which split asunder lengthwise. Each split part is composed of one-half of a ripened carpel, Fig. 100 (2).

A **Cremocarp** is the characteristic splitting fruit of the Umbelliferæ family. It consists of two inferior akenes or mericarps separated from each other by a forked stalk called a *carpophore*. These mericarps usually cling to the forks of the carpophore for a time after the cremocarp splits, but sooner or later fall, Fig. 100 (1).

A **Samara** is a winged splitting fruit. It may be one-carpelled as in the Elm, Ash, Tulip Poplar and Wafer Ash or two-carpelled as in the Maples, Fig. 100 (3 and 4).

A **Lomentum** or **Loment** is a splitting fruit that splits transversely into one-seeded portions. Seen in *Cruciferae*, in *Entada scandens*, *Cathartocarpus Fistula*, *Desmodium*, etc. of *Leguminosae*, Fig. 100 (5).

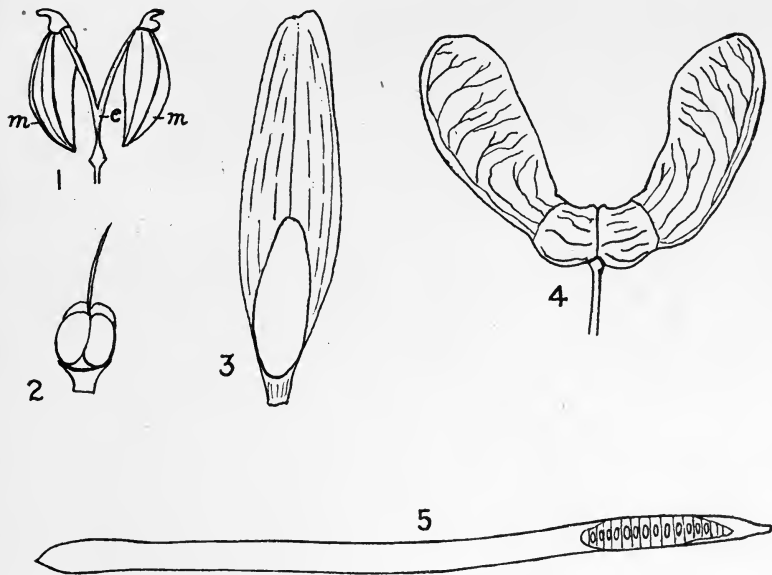

FIG. 100.—Schizocarpic fruits. 1, Cremocarp of Fennel, composed of two mericarps (*m*) and a split carpophore (*c*); 2, carcerulus of the Bugle; 3, one-carpelled samara of the Ash; 4, double samara of the maple; 5, loment of purging cassia, a portion of the pericarp being removed to show chambers, each containing a single seed.

III. **Achenial Fruits** (all indehiscent).—The **Akene** is a dry one-chambered, indehiscent fruit, in which the pericarp is firm and may or may not be united with the seed, the style remaining in many cases as an agent of dissemination, Fig. 101 (1). The latter may be long and feathery as in *Clematis* or be hooked. Examples of akenes: Fruits of the *Compositae*, *Anemone*, etc. The *Hip* of the

Roses consists of a number of akenes in a ripened concave receptacle.

The **Utricle** is like the akene, except that the enveloping calyx is loose and bladder-like. Example: *Chenopodium*, Fig. 101 (3).

A **Caryopsis** or **Grain** is similar to an akene but differs from it by the pericarp being always fused with the seed coat. This fruit is

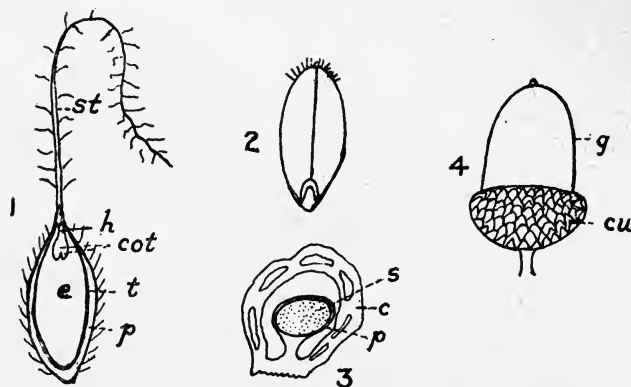

FIG. 101.—Achenial fruits. 1, Akene of *Pulsatilla* cut vertically, showing adherent feathery style (*st*), pericarp (*p*), testa (*t*), endosperm (*e*), hypocotyl (*h*) and cotyledons (*cot*) the last two structures making up the embryo; 2, caryopsis of wheat showing beard of hairs above and position of embryo of seed below; 3, utricle of *Chenopodium* cut vertically to show calyx (*c*), pericarp (*p*) and seed (*s*) regions; 4, nut of an oak consisting of a glans (*g*) and cupule (*cu*).

more likely than any other to be mistaken for a seed. Examples: Wheat, Corn, Barley, Oats and other members of the *Gramineæ*, Fig. 101 (2).

A **Nut** or **Glans** is a one-celled, one-seeded fruit with a leathery or stony pericarp. Examples: Oaks, Beeches, Chestnuts, Alders and Palms, Fig. 101 (4).

IV. **Baccate Fruits** (Succulent fruits in which the endocarp is always succulent and the mesocarp sometimes).—The **Berry** is a small fleshy fruit with a thin membranous epicarp and a succulent interior in which the seeds are imbedded. Examples: Capsicum, Tomato, Belladonna, Grape, Currant, etc.

An **Uva** is a berry from a superior ovary. Examples: Belladonna, Egg-plant, Tomato, Fig. 102 (1).

A **Bacca** is a berry from an inferior ovary. Examples: Gooseberry, Honeysuckle, Currant.

The **Pepo** or **Gourd Fruit** is a baccate fruit of large size which has developed from an inferior ovary. It is fleshy internally and has a tough or very hard rind. Examples: Fruits of the *Cucurbitaceae* and the Banana, Fig. 102 (2).

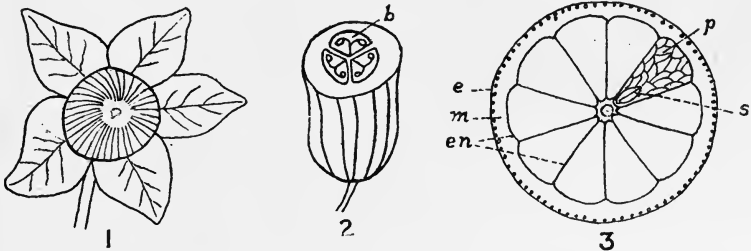

FIG. 102.—Baccate fruits. 1, berry (uva) of Belladonna with adherent calyx; 2, Pumpkin, cut transversely illustrating a pepo fruit; (*h*), a locule; 3, hesperidium fruit of the Orange cut transversely showing epicarp (*e*), mesocarp (*m*), endocarp (*en*), pulp (*p*), and seed (*s*).

The **Hesperidium** is a large thick-skinned succulent fruit with seeds embedded in the pulp but from a superior ovary. Examples: Orange, Grape-fruit, Lemon, etc. In each of these there is to be noted a glandular leathery epicarp, a sub-leathery mesocarp and an endocarp in the form of separate carpels. From the endocarp hairs grow inward into the carpellary cavities and become filled with succulence. The seeds lie amid the hair cells, Fig. 102 (3).

**V. Drupaceous Fruits** (Succulent fruits in which the mesocarp is more or less succulent, but the endocarp leathery or stony).—A **Drupe** is a one-celled, one-seeded drupaceous fruit such as the fruit of the Plum, Peach, Prune, Sabal, Rhus, Piper, Cherry, etc., whose endocarp or putamen is composed wholly of stone cells or stone cells and sclerenchyma fibers, Fig. 103 (1).

The **Pome** is a fleshy drupaceous fruit, two or more celled with fibrous or stony endocarp, the chief bulk of which consists of the

adherent torus. Quince, Apple and Pear are examples. The carpels constitute the core, and the fleshy part is developed from the torus, Fig. 103 (2).

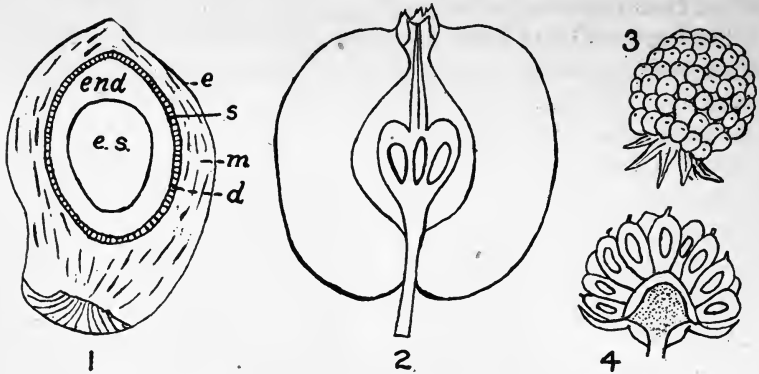

FIG. 103.—1, Drupe of cocoanut cut vertically, showing epicarp (*e*), mesocarp (*m*), stony endocarp (*d*) seed coat (*s*), endosperm (*end*), and embryo sac cavity (*e.s.*) which in the mature seed contains a nutritive fluid. 2, Pome of an apple cut vertically to show core composed of 5 ripened carpels and flesh of matured torus. 3, Æstrio of raspberry. 4, Same, cut vertically to show arrangement of the little drupes on fleshy receptacle.

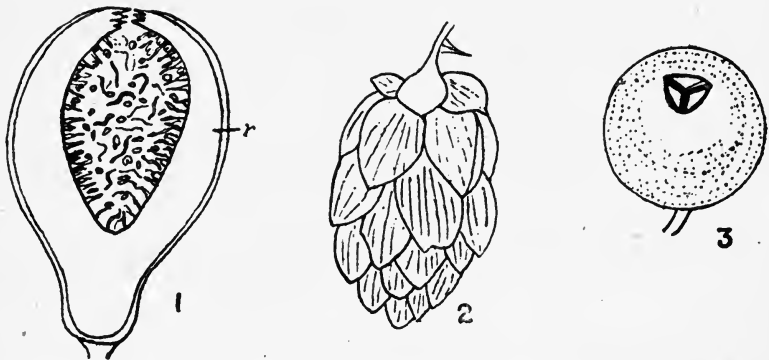

FIG. 104.—Multiple fruits. 1, Syconium of Fig cut vertically to show hollowed out receptacle (*r*) of ripened flower cluster; 2, strobile of the hop; 3, galbalus of Juniper.

**Aggregate Fruits.**—An **Æstrio** consists of a collection of little drupes on a torus of a single flower. Examples: Raspberry, Blackberry, etc., Fig. 103 (3 and 4).



**Multiple Fruits.**—The **Syconium** is a multiple fruit consisting of a succulent hollow torus enclosed within which are akene-like bodies, products of many flowers. Example: Fig. 104 (1).

The **Sorosis** is represented by the Mulberry, Osage Orange, etc., the grains of which are not the ovaries of a single flower, as in the Blackberry, but belong to as many separate flowers. In the Pineapple all the parts are blended into a fleshy, juicy, seedless mass, and the plant is propagated by cuttings.

The **Strobile** or **Cone** is a scaly, multiple fruit consisting of a scale-bearing axis, each scale enclosing one or more seeds. The name is applied to the fruit of the Hop, Fig. 104 (2), and also to the fruit of the *Coniferae* in which the naked seeds are borne on the upper surface of the woody scales.

A **Galbalus** is a more or less globular multiple fruit formed of fleshy connate scales, as in Juniper, Fig. 104 (3).

**Histology of a Capsule, Vanilla.**—The Vanilla fruit is a one-celled capsule formed by the union of three carpellary leaves and dehiscing by two unequal longitudinal valves.

**Microscopic Appearance of a Transverse Section.**—Passing from periphery toward the center, the following structures present themselves:

1. **Epicarp**, consisting of *epidermis* and *hypodermis*. The *epidermis* consists of a layer of thick-walled epidermal cells whose outer walls show the presence of a thin yellow cuticle. Stomata are present in this tissue. The epidermal cells contain protoplasm and brownish bodies. Some also contain small prisms of calcium oxalate and a few, vanillin crystals. The *hypodermis* is composed of one to several layers of collenchymatic cells with dark-colored contents. Its cells are somewhat larger than those of the epidermis and thicker-walled.

2. **Mesocarp**, a broad region of somewhat loosely arranged large, thin-walled parenchyma cells becoming smaller in the inner zone of this region. Most of these cells contain brownish contents but some possess long raphides of calcium oxalate. If the section be mounted in phloroglucin solution (5 per cent.) and a drop of strong sulphuric acid is added, a carmine-red color will be observed showing the presence of vanillin in this region. Several closed collateral bundles will be seen coursing through the mesocarp.

3. **Endocarp**, an irregular line of inner epidermal cells which is differentiated into two regions, the interplacental region and the placental region. The interplacental (inner) epidermis shows its cells elongated into numerous thin-walled glandular hairs which contain an abundance of balsam; the placental region covers the six bifid *placentæ* which extend into the cavity of the capsule. Its (inner) epidermis is composed of mucilaginous cells.

4. **Seeds**.—These are minute blackish bodies attached to the placental twigs of the *placentæ*. Some of them may have been torn off in cutting the section.

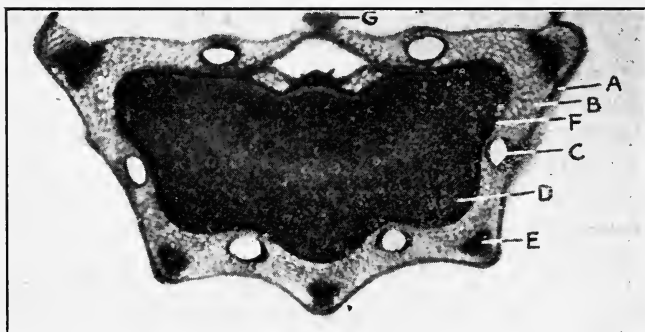

FIG. 105.—Photomicrograph of a transverse section of a mericarp of *Foeniculum vulgare*, showing epicarp (A), mesocarp (B), endocarp (F), vitta (C), endosperm of seed (D), carpophore (G) and fibro-vascular bundle in primary rib (E). (Highly magnified.)

**Histology of a Typical Mericarp, *Foeniculum*.**—This five-angled fruit, in transverse section, shows a concave commissural and convex dorsal surface. Passing from the surfaces toward the center we note:

1. *Epicarp*, or outer covering tissue, composed of colorless epidermal cells and small stomata. The epidermal cells in cross-section appear rectangular, while in surface view they are both polygonal and rectangular.

2. *Mesocarp*, of several layers of thin-walled colorless isodiametric cells, beneath which are two to several additional layers of thicker-walled cells with brownish walls. Through the angles or rib portions of the mesocarp extend the fibro-vascular bundles.

Between each fibro-vascular bundle and the tip of each rib will be found a zone of collenchyma cells. In the mesocarp between each two ribs on the dorsal side occurs a single *vitta* or oil tube which is lined with a layer of brownish polygonal cells. These *vittæ* contain the official oil of fennel. Two *vittæ* generally occur in the mesocarp of the commissural side although four are reported to have been found in this region of some fennel fruits.

3. *Endocarp*, a narrow layer of cells, transversely elongated, except over the regions of bundles where they may be seen elongated in several directions.

4. *Spermoderm* or *Seed Coat*, consisting of a layer of somewhat broadened epidermal cells attached to the endocarp and several layers of collapsed cells which are only well defined in the region of the *raphe*.

5. *Endosperm*, a central mass of more or less polygonal cells containing aleurone grains and oil globules. Each aleurone grain contains a rosette aggregate of calcium oxalate and one or two globoids.

6. Embryo, embedded in the endosperm of the upper region of the seed.

## THE SEED

A *seed* is a matured megasorus (ovule) borne by the sporophyte of a spermatophytic plant, enclosing a megaspore (embryo sac) within which a fertilized egg of the succeeding gametophyte generation has segmented to form a new sporophyte plant. The purpose of the seed is to insure the continuation and distribution of the species. Like the ovule, it consists of a nucellus or kernel enclosed by integuments, and the descriptive terms used are the same. The seed coats, corresponding to those of the ovule, are one or two in number. If but one seed coat is present it is termed the *spermoderm*. If two are present, the outer one is called the *testa*, and the inner one the *tegmen*. The *testa*, or outer seed shell, differs greatly in form and texture. If thick and hard, it is crustaceous; if smooth and glossy, it is polished; if roughened, it may be pitted, furrowed, hairy, reticulate, etc.

The *testa* may often present outgrowths or seed appendages whose functions are to make the seeds buoyant, whereby they may be dis-

seminated by wind currents. Examples of these are seen in the Milkweed, which has a tuft of hairs at one end of the seed called a *Coma*, and in the official **Strophanthus**, which has a long bristle-like appendage attached to one end of the seed and called an *awn*. The wart-like appendage at the hilum or micropyle, as in Castor Oil Seed, is called the *Caruncle*.

The tegmen or inner coat surrounds the nucellus closely and is generally soft and delicate.

A third integument, or accessory seed covering outside of the testa, is occasionally present and is called the *Aril*. Example: *Euonymus* (succulent).

When such an integument arises from the dilatation of the micropyle of the seed, as in the Nutmeg, it is known as an *Arillode*.

The *Nucellus* or *Kernel* consists of tissue containing albumen, when this substance is present, and the *embryo*. Albumen is the name given the nutritive matter stored in the seed. The funiculus or seed stalk is usually absent in the official seeds. The scar left by its separation is called the *hilum*. When the funiculus is continued along the outer seed coat, it is called the *raphe*.

#### MODE OF FORMATION OF DIFFERENT TYPES OF ALBUMEN

If the egg-cell within the embryo sac segments and grows into the embryo and, stretching, fills up the cavity without food material laid down around it, it happens that the nutritive material lingers in the cells of the nucellus, pressing around the embryo. This is called *Perispermic albumen*. Seen in the *Polygonaceæ*.

In by far the greater number of Angiosperms, the endosperm nucleus, after double fertilization, divides and redivides, giving rise to numerous nuclei imbedded in the protoplasm of the embryo sac, outside of the developing embryo. Gathering protoplasm about themselves and laying down cell walls they form the endosperm tissue outside of the embryo. Into this tissue food is passed constituting the *Endospermic albumen*.

In the *Marantaceæ*, *Piperaceæ*, etc., nutritive material is passed into the nucellar cells causing them to swell up, while to one side a small patch of endosperm tissue accommodates a moderate amount

of nourishing substance, thus resulting in the formation of abundant perisperm and a small reduced *endosperm*.

*Exalbuminous seeds* are those in which the albumen is stored in the embryo during the growth of the seed. Such seeds show the fleshy embryo taking up all or nearly all the room within the seed coat. Examples: **Physostigma, Amygdala**, etc.

*Albuminous seeds* are those in which the nourishment is not stored in the embryo until germination takes place. Such seeds show a larger nourishing tissue region and a smaller embryo region. Examples: **Nux Vomica, Myristica, Linum**, etc.

**Gross Structure of a Monocotyl Seed** (*With fruit wall attached*), *Indian Corn*.—The ripened seed of Indian Corn is surrounded by a thin, tough pericarp which is firmly adherent to and inseparable from the *Spermoderm* or seed coat. Because of this fact, while in reality a fruit called a caryopsis or grain, this structure is sometimes erroneously termed a seed.

The mature grain of most varieties of Indian Corn is flattened and somewhat triangular in outline, the summit being broad and the base comparatively narrow. The summit is indented and often marked by a small point which represents a vestige of the style. The basal or "tip" region marks the part of the grain which was inserted into the cob. Upon it may be found papery chaff, representing parts of the pistillate spikelets. The groove noted on the broader surface indicates the position of the embryo.

**Histology of the Indian Corn Seed** (*With fruit wall attached*).—If a longitudinal section be cut through the lesser diameter of a soaked grain, the following histologic characteristics will be observed:

1. The *Pericarp* or ripened ovarian wall which, alike with all other grains, adheres firmly to the wall of the seed forming a portion of the skin of the grain. The pericarp comprises an outer epicarp of elongated cells with thin cuticle, a mesocarp of thicker walled cells without, becoming thinner within, and a layer of tube cells.

2. The *Spermoderm* or seed coat, a single layer of delicate elongated cells.

3. The *Perisperm*, another layer directly underneath the *Spermoderm*, difficult to distinguish without special treatment, and representing the ripened nucellar tissue of the ovule.

4. The *Endosperm* or nourishing tissue, consisting of: (a) The Aleurone Layer, for the most part a single row of cells, containing aleurone grains. Some of the cells may be seen to be divided by tangential partitions. (b) Starch Parenchyma, consisting of two regions: an outer horny zone composed of cells containing for the most part polygonal starch grains and oil droplets; and an inner mealy zone of cells with mostly rounded starch grains.

5. The *Embryo*, consisting of a single shield-shaped cotyledon adjoining the endosperm, the plumule or rudimentary bud at the end of the caulicle or rudimentary stem and the radicle or rudimentary root, with its tip covered by a root cap. Continuous with the root cap is a root sheath or *coleorhiza*. The cotyledon or seed leaf consists of two parts: the *scutellum* which lies next to the endosperm, and is an organ of absorption; and the *sheathing portion* which surrounds and protects the rest of the embryo.

The embryo contains oil and proteids, but no starch.

If a similar longitudinal section of a soaked grain be mounted in dilute iodine solution, the contents of the aleurone cells will be colored yellow indicating their proteid nature, while the starch grains will take on a blue to violet coloration. The endosperm will be observed taking up most of the room within the seed coat. The contents of its cells are not baled out to the embryo until after germination begins. Indian Corn is therefore an *albuminous seed*.

#### A MONOCOTYL SEEDLING

**Germination.**—When any viable seed is planted in suitable soil, and furnished with oxygen and water and a certain degree of heat, *germination* takes place. In the presence of moisture, etc., the seed swells, the ferments present within the cells of the endosperm then change the insoluble proteid, starch, and oil to soluble materials, which, in the case of Indian Corn, are absorbed in solution by the scutellum which bales this nourishment out to other parts of the growing embryo, there to be used in part in constructing new tissues, and in part to be consumed by oxidation or respiration. The process of respiration or breathing takes place when the plant takes in oxygen and gives off carbon dioxide. The oxygen oxidizes the tissues

with an accompanying release of energy, which latter is necessary to life and growth.

The combined pericarp and spermoderm bursts opposite the tip of the radicle, and the radicle, piercing through the cotyledonary sheath, protrudes. The cleft in the coat lengthens to the point opposite the tip of the plumule, which also protrudes after bursting through the cotyledonary sheath. The radicle, next, grows downward into the soil forming the primary root, and develops upon itself secondary or lateral roots, all of which give rise to root-hairs just above their root caps. Additional lateral roots emerge above the scutellar region which ere long attain the size of the first or primary root. The caulicle, carrying upon its tip the plumule, elongates and forms the stem; the leaves of the plumule spread out and turn green to function as foliage leaves. The perforated cotyledonary sheath grows out surrounding both the root and the stem for a portion of their length. By this time all or nearly all of the nourishment stored in the endosperm has been absorbed and assimilated by the young seedling and the coat and scutellum, left behind, gradually decay and disappear. The root-hairs absorb nourishment from the soil, the green leaves build up carbohydrates, prop-roots make their appearance at the first node (joint) above ground, and the seedling grows larger.

#### **Gross Structure of a Dicotyl Seed, *Phaseolus lunatus* (Lima Bean).**

—The Lima Bean Seed shows a flattened-ovate to somewhat reniform outline. Externally it exhibits a polished seed coat which is perforated on its basal side by a minute pore called the *micropyle* or *foramen*. Just below this pore will be noted the *hilum* or scar which represents the point of detachment from the *funiculus* or stalk, which connected the seed during its growth with the wall of the fruit. Upon soaking the seed in water, it is possible to remove the *seed coat* or *spermoderm*. This done, the embryo will be exposed. The *two fleshy cotyledons* are first seen. Upon spreading these out, convex sides down, the rest of the embryo, consisting of a thin leafy structure surrounding a bud and called the *plumule*, the *caulicle* or rudimentary stem and in line with the latter, the *radicle*, or rudimentary root, will be seen.

**Histology of the Lima Bean Seed.**—In transverse sections, the following microscopic structures will be evident:

1. *Spermoderm* of three regions, viz.: Palisade cells, Column cells, and Spongy Parenchyma. The palisade cell layer is composed of vertically elongated thick-walled cells which are covered on their outer faces by a clear glistening cuticle. The cells are 60 to 80 $\mu$  long and 12 to 20 $\mu$  wide. The column cells, found forming a layer directly beneath the palisade zone, are hour-glass-shaped and 25 to 35 $\mu$  long by 14 to 35 $\mu$  wide.

The *spongy parenchyma* forms a zone of several layers of thin-walled parenchyma cells, the cells of the outer and inner layers being considerably smaller than the middle layers.

2. *Embryo*, the two cotyledons of which make up the greatest bulk. These are composed of an epidermis covering over a region of mesophyll. The mesophyll is constituted of moderately thick-walled cells which contain ellipsoidal and kidney-shaped starch grains up to 65 $\mu$  in length. A conspicuous branching cleft will be seen in the larger grains.

In the Lima Bean, the nourishment is stored in the embryo during the growth of the seed. It is, therefore, *exalbuminous*.



## CHAPTER VIII

### TAXONOMY

#### DIVISION I.—THALLOPHYTA

Plants, the greater number of which, consist of a *thallus*, a body undifferentiated into root, stem or leaf. The group nearest to the beginning of the plant kingdom presenting forms showing rudimentary structures which are modified through division of labor, differentiation, etc., in higher groups.

#### SUBDIVISION I.—PROTOPHYTA (SCHIZOPHYTA)

A large assemblage of "fission plants" comprising the bacteria and blue-green algæ. In the simplest types no nucleus is present, but as we arise in scale through the bacteria and blue-green algæ, there is to be observed an open granular, gradually growing to a crescentic, chromatin mass that may be called a nucleus. A common method of asexual reproduction is possessed by these plants whereby the cell cleaves or splits into two parts, each of which then becomes a separate and independent organism.

#### I. SCHIZOMYCETES—BACTERIA

Bacteria are minute, unicellular, colorless, rarely weakly red or green colored, non-nucleate vegetable organisms destitute of chlorophyll. They serve as agents of decay and fermentation and are frequently employed in industrial processes. According to the various phenomena they produce, they may be classified as follows: (a) Zymogens producing fermentation; (b) Aerogens producing gas; (c) Photogens producing light; (d) Chromogens producing color; (e) Saprogens, producing putrefaction; (f) Pathogens, producing disease.

#### Physical Appearance of Bacterial Colonies and Individual Forms.

Because of their minute size—a space the size of a pinhead may

hold eight billion of them—the student commences his study of bacterial growths in colonies or cultures, each kind possessing characteristics by which they may be distinguished and differentiated.

The individuals in the colony, depending upon the kind of bacteria under examination, may be globular, rod-shaped, or spiral. Bacteria are classed according to form into the following families and genera.



FIG. 106.—Types of micrococci. (After Williams.)

**Family I.—Coccaceæ.**—Cells in their free condition globular, becoming but slightly elongated before division. Cell-division in one, two or three directions of space.

A. Cells without Flagella.

1. Division only in one direction of space forming an aggregation resembling a chain of beads—*Streptococcus*.

2. Division in two directions of space forming an aggregation resembling a cluster of grapes—*Staphylococcus*.



FIG. 107.—Types of bacilli. (After Williams.)

3. Division in three directions of space forming a package-shaped or cubical aggregation—*Sarcina*.

B. Cells with Flagella.

1. Division in two directions of space—*Planococcus*.

2. Division in three directions of space—*Planosarcina*.

**Family II.—Bacteriaceæ.**—Cells longer than broad, generally two to six times, straight or only with an angular bend, never curved or spiral, division only at right angles to axis or rod; with or without flagella and endospores.

1. Flagella and endospores absent—*Bacterium*.

2. Flagella and endospores present—*Bacillus*.

**Family III.—Spirillaceæ.**—Cells curved or spirally bent, generally motile through polar flagella.

1. Cells stiff, not flexible.

(a) Cells without flagella—*Spirosoma*.

(b) Cells with one, very rarely with two polar flagella—*Microspira*.

(c) Cells with a bundle of polar flagella—*Spirillum*.

2. Cells flexible, spiral very close—*Spirochæta*.

**Family IV.—Mycobacteriaceæ.**—Cells short or long cylindrical or clavate-cuneate in form, without a sheath surrounding the chains of individuals, without endospores, with true dichotomous branching.

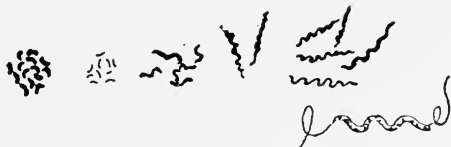

FIG. 108.—Types of spirilla. (After Williams.)

A. In cultures possessing the characters of true bacteria. Growth on solid media smooth, flat, spreading. Rod with swollen ends, or cuneate or clavate forms—*Corynebacterium*.

B. Cultures on solid media raised, folded or warty. Generally short slender rods, rarely short branched. Take the tubercle stain—*Mycobacterium*.

**Family V.—Chlamydobacteriaceæ.**—Thread-like, composed of individual cells, surrounded by a sheath. Simple or with true branching. Ordinary vegetative growth by division in only one direction of space, *i.e.*, at right angles to the longer axis.

A. Cell contents without sulphur granules.

1. Filaments unbranched.

(a) Cell-division only in one direction of space.

(b) Cell-division in gonidial formation in three directions of space—*Streptothrix*.

\*Marine forms with cells surrounded by a very delicate hardly discernible sheath—*Phragmidiothrix*.

**\*\*Fresh-water forms with easily discernible sheath—Crenothrix.**

2. Filaments branched.

B. Cell contents with sulphur granules—Thiothrix.

**Family VI.—Beggiatoaceæ.**—Thread-like, without a capsule, but with an undulating membrane. Cell contents show sulphur granules.

A. Threads apparently not septated, septa only faintly visible with iodine staining. Colorless or faintly rose-colored—Beggiatoa.

**Sporulation.**—A large number of bacteria possess the power of developing into a resting stage by a process known as sporulation or spore formation. Sporulation is regarded as a method of resisting unfavorable environment. This is illustrated by the anthrax bacilli which are readily killed in twenty minutes by a 10 per cent. solution of carbolic acid, and able, when in the spore condition, to resist the same disinfectant for a long period in a concentration of 50 per cent. And, while the vegetative forms show little more resistance against moist heat than the vegetative form of other bacteria, the spores will withstand the action of live steam for as long as ten to twelve minutes or more.

Whenever the spores are brought into favorable condition for bacterial growth, as to temperature, moisture and nutrition, they return to the vegetative form and then are capable of multiplication by fission in the ordinary way.

**Reproduction.**—Bacteria multiply and reproduce themselves by cleavage or fission. A young individual increases in size up to the limits of the adult form, when by simple cleavage at right angles to the long axis, the cell divides into two individuals.

**Morphology Due to Cleavage.**—According to limitations imposed by cleavate directors, the cocci assume a chain appearance, or a grape-like appearance, or an arrangement in packets or cubes having three diameters. This gives rise to the

*Staphylococcus* (plural, *staphylococci*), from a Greek word referring to the shape of a bunch of grapes.

*Streptococcus* (plural, *streptococci*), from a Greek word meaning chain-shaped.

*Sarcina*, package-shaped or cubical.

**Form of Cell Groups after Cleavage.**—The individual bacteria after cleavage may separate, or cohere. The amount of cohesion, together with the plane of cleavage, determines the various forms of the cell groups. Thus, among the cocci, diplo- or double forms may result giving rise to distinguishing morphological characteristics. Similarly among the bacilli characteristic forms result as single individuals and others which form chains of various lengths.

**Rapidity of Growth and Multiplication.**—The rapidity with which bacteria grow and multiply is dependent upon species and environment. The rapidity of the growth is surprising. Under favorable conditions they may elongate and divide every twenty or thirty minutes. If they should continue to reproduce at this rate for twenty-four hours a single individual would have 17 million descendants. If each of these should continue to grow at the same rate, each would have in twenty-four hours more, 17 million offspring, and then the numbers would develop beyond conception. However, such multiplication is not possible under natural or even artificial conditions, both on account of lack of nutritive material and because of the inhibition of the growth of the bacteria by their own products. If they did multiply at this rate in a few days there would be no room in the world but bacteria.

**Chemical Composition of Bacteria.**—The quantitative chemical composition of bacteria is subject to wide variations, dependent upon the nutritive materials furnished them. About 80 to 85 per cent. of the bacterial body is water; proteid substances constitute about 50 to 80 per cent. of the dry residue. When these are extracted, there remain fats, in some cases wax, in some bacteria traces of cellulose appear, and the remainder consists of 1 to 2 per cent. ash.

The proteids consist partly of nucleo-proteids, globulins, and protein substances differing materially from ordinary proteids. Toxic substances known as endotoxins to distinguish them from bacterial poisons secreted by certain bacteria during the process of growth, also occur.

SOME BACTERIA PRODUCING DISEASES IN MAN OR THE  
LOWER ANIMALS

| <i>Organism</i>                                   | <i>Disease</i>                              |
|---|---|
| Staphylococcus pyogenes aureus.....               | Boils, abscesses, carbuncles                |
| Streptococcus erysipelatis.....                   | Erysipelas                                  |
| Micrococcus meningitidis.....                     | Cerebrospinal meningitis                    |
| Micrococcus gonorrhœæ.....                        | Gonorrhœa                                   |
| Micrococcus melitensis.....                       | Malta fever                                 |
| Micrococcus catarrhalis.....                      | Catarrh                                     |
| Bacillus anthracis.....                           | Anthrax                                     |
| Bacterium diphtheriæ.....                         | Diphtheria                                  |
| Bacillus typhosus.....                            | Typhoid fever                               |
| Bacterium influenza.....                          | Influenza                                   |
| Bacillus tetani.....                              | Tetanus                                     |
| Bacillus lepræ.....                               | Leprosy                                     |
| Bacillus chauvei.....                             | "Blackleg" of cattle                        |
| Bacillus aërogenes capsulatus.....                | Emphysematous gangrene                      |
| Bacterium tuberculosis.....                       | Tuberculosis                                |
| Bacterium mallei.....                             | Glanders                                    |
| Streptococcus pneumoniae (Diplococcus pneumoniae) | Pneumonia (croupous or fibrinous pneumonia) |
| Spirillum cholerae asiaticæ.....                  | Cholera                                     |
| Spirillum obermeieri.....                         | Relapsing fever                             |
| Streptothrix (Actinomyces) bovis.....             | Actinomycosis in cattle                     |

*Some Bacteria Producing Diseases in Plants*

|                             |  |
|-----------------------------|--|
| Actinomyces Myricarum.....  | Tubercles upon and lesions within Myrica and Comptonia |
| Bacterium tumefaciens.....  | Crown gall   |
| Bacterium savastanoi.....   | Olive knot   |
| Bacillus amylovorus.....    | Pear blight  |
| Pseudomonas juglandis.....  | Walnut blight  |
| Bacillus Solanacearum.....  | Wilt of Solanaceæ                                      |
| Bacillus tracheiphilus..... | Wilt of Cucurbits                                      |
| Pseudomonas Stewarti.....   | Wilt of Sweet Corn                                     |

**Mounting and Staining of Bacteria.**—The mounting and staining of bacteria may be accomplished as follows:

1. Take the square or round cover slip, which has been previously cleaned, out of the alcohol pot. Dry it between filter paper.
2. Hold it in the bacteriologic forceps, which is so constructed that a spring holds the cover slip firmly while an enlargement of the wire

handle permits the placing of the forceps on the table while the culture material is obtained.

3. Place several drops of distilled water on the cover slip and add a loop full of the organism secured from the pure culture in a test tube as follows:

4. Remove the cotton plug by the third and fourth fingers of the left hand.

5. Hold the open test tube between the thumb and forefinger of the left hand.

6. By means of a previously flamed platinum needle, remove a little of the culture from the surface of the culture media.

7. Replace the cotton plug.

8. Add the culture media to the drop of distilled water on the cover slip and distribute this material by stirring.

9. Evaporate the water on the cover slip to dryness by holding it some distance above the Bunsen flame and slowly enough to prevent connection circles being formed by the material affixed to the cover.

10. Pass the cover glass three times through the Bunsen flame.

11. Apply the stain, which should remain long enough to stain the objects.

12. Wash off the stain with distilled water.

13. Dry the cover glass above the flame.

14. Apply a drop of balsam, turn the cover slip over and drop it on to the center of a glass slide previously provided and cleaned for this purpose.

**Gram's Method.**—This is a method of differential bleaching after a stain. The cover glass preparations or sections are passed from absolute alcohol into Ehrlich's anilin gentian violet, where they remain one to three minutes, except tubercle bacilli preparations which remain commonly twelve to twenty-four hours. They are then placed for one to three minutes (occasionally five minutes) in iodine potassium iodide water (iodine crystals 1, potass. iodide 2, water 300), with or without washing lightly in alcohol. In this they remain one to three minutes. They are then placed in absolute alcohol until sufficiently bleached, after which they are cleared in clove oil and mounted in balsam.

Certain organisms, when stained by this method give up the stain

and are called "Gram negative; " others retain the color and are called "Gram positive." Examples of the latter are *B. diphtheriæ*, *Bacillus anthracis*, and *Bacillus tetani*.

**Stains.**—One of the most useful bacteriologic stains is *Ziehl's Carbol Fuchsin*, prepared as follows:

Fuchsin (basic), 1.

Absolute Alcohol, 1.

Carbolic Acid (5 per cent. aqueous solution), 100.

The fuchsin should be dissolved first in the alcohol and then the two fluids mixed.

**Ehrlich's Anilin Water Gentian Violet.**—Anilin Oil Water, 75 parts.

Sat. Sol. Gentian Violet in Alcohol, 25 parts.

Anilin oil water is made by adding 2 mls anilin to 98 mls distilled water; shake violently. Filter through filter paper several times.

**Löffler's Methylene-blue.**—

Sat. sol. Methylene-blue in Alcohol . . . . . 30 mls

Sol. KOH in distilled water (1:10,000). . . . . 100 mls

Mix the solutions.

**Stain for "Acid Proof" Bacteria Including *B. Tuberculosis*.**—

1. Flood the cover glass with *Ziehl's carbol fuchsin* and boil over the flame for thirty seconds.

2. Wash and decolorize with a 2 per cent. solution of HCl in 80 to 95 per cent. alcohol until the thinner portions of the film show no red color.

3. Wash in water.

4. Counter stain for contrast with *Löffler's Methylene-blue*.

5. Wash and examine.

**Van Ermengem's Flagella Stain.**—1. Mordant:

Osmic acid (2 per cent. aqueous solution). . . . . 50

Tannin (10 to 25 per cent. in water). . . . . 100

Four drops of glacial acetic acid may be added to this.

2. Silver Bath:

Dissolve 0.25 to 0.5 per cent. nitrate of silver in distilled water in a clean bottle.



## 3. Reducing and Strengthening Bath:

|                           |     |
|---------------------------|-----|
| Gallic acid.....          | 5   |
| Tannin.....               | 3   |
| Fused sodium acetate..... | 10  |
| Distilled water.....      | 350 |

The flamed cover glass is first covered with the mordant for one-half hour, or if in a thermostat at 50°C. for five to ten minutes. The mordant is then carefully removed by thorough washing in water, alcohol and water. The cover (film side up) is now put into the silver bath (a few mils in a clean beaker or watch glass) for a few seconds, during which time it is gently agitated. Without rinsing it is next put into a few mils of the reducing solution and gently agitated until the fluid begins to blacken. It is then washed in water and examined. If not stained deeply enough the cover is returned to the silver bath. It is finally dried and mounted in balsam. All the dishes must be scrupulously clean. The fluids must not be contaminated by the fingers nor by dipping iron or steel instruments into them.

**Broca's Differential Stain.**—

|                               |         |
|-------------------------------|---------|
| Löffler's Methylene Blue..... | 80 mils |
| Ziehl's Carbol Fuchsin.....   | 10 mils |

Mix the solutions.

This stain differentiates between dead and living bacteria. Dead bacteria take on a red coloration and living bacteria a blue color.

## 2. CYANOPHYCEÆ

Plants which are sometimes termed *blue-green algæ*. They contain chlorophyll, a green pigment, and phycocyanin, a blue pigment, a combination giving a blue-green aspect to the plants of this group. Found everywhere in fresh and salt water and also on damp logs, rocks, bark of trees, stone walls, etc. Examples: *Oscillatoria*, *Glæocapsa*, and *Nostoc*.

**Glæocapsa.**—This blue-green alga is commonly found on old, damp flower pots in greenhouses and on damp rocks and walls

near springs, where it forms slimy masses. Under the microscope a mount of *Gloëocapsa* will be seen to consist of isolated protoplasts and groups of protoplasts, surrounded by concentric gelatinous

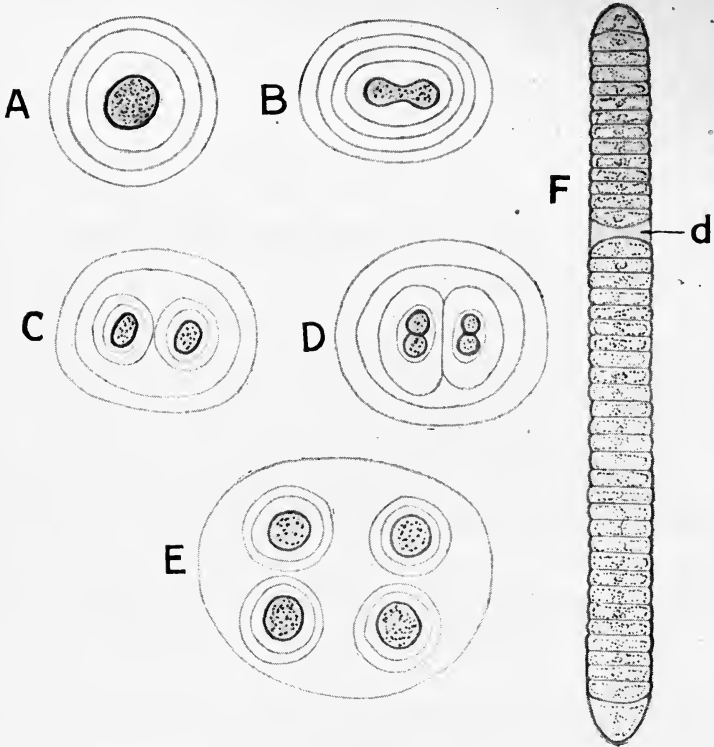

FIG. 109.—A, B, C, D, E, *Gloëocapsa*; F, *Oscillatoria* showing a dead cell (d) which marks a place of separation into segments. (A), *Gloëocapsa*, parent cell composed of central protoplast containing scattered chromatin granules, surrounded by cell wall and 3 mucliaginous envelopes; (B), parent cell is shown elongated, the protoplast in process of division to form two daughter protoplasts; (C), daughter protoplasts, each surrounded by two gelatinous envelopes and both within the original parent envelopes; (D) the daughter protoplasts shown in C have just divided to form granddaughter protoplasts which have later separated, each forming envelopes of its own but all four encircled by the parent envelope.

envelopes. Each protoplast consists of a protoplasmic mass which contains blue and green pigments. No definitely organized nucleus is apparent but chromatin in the form of granules is scat-

tered through the protoplasm. The whole is surrounded by a cell wall which undergoes mucilaginous modification producing thus the soft gelatinous envelopes which encircle parent-, daughter-, grand-daughter- and even great-grand-daughter-cells.

**Oscillatoria.**—Oscillatoria is a blue-green filamentous organism found abundantly on the surface of the mud of drains and ditches as well as in ponds where the water is foul. The filament is slender and composed of compactly arranged disc-shaped cells which are all alike, excepting the terminal ones which appear rounded off. The filaments tend to be agglomerated in thick felts or gelatinous masses and each possesses peculiar oscillating and forward movements. At the time of reproduction the filament breaks up transversely into short segments, each of which, by fission occurring among its cells, grows into a new filament.

**Nostoc.**—Nostoc occurs on the damp ground bordering streams or in slow bodies of water as greenish or brownish tough gelatinous masses varying in size from a pea to a hen's egg. When one of these masses is dissected and examined microscopically, it is seen to contain, imbedded in a gelatinous matrix, numerous serpentine filaments, composed of spherical or elliptical cells loosely attached to each other in chain-like fashion. Most of the cells are of the blue-green vegetative kind but there occur at intervals larger cells, often devoid of protoplasm which are termed *heterocysts*. Frequently the filaments break apart on either side of the heterocyst, setting free segments of cells which grow into new filaments.



FIG. 110.—*Nostoc*. (*h*), a heterocyst.

## SUBDIVISION II.—MYXOMYCETES, OR SLIME MOLDS

Terrestrial or aquatic organisms, frequently classified as belonging to the animal kingdom and found commonly on decaying wood, leaves, or humous soil in forests. Their vegetative body consists of a naked, multinucleated mass of protoplasm called the *plasmodium*, which has a creeping and rolling amœboid motion, putting out and retracting regions of its body called *pseudopodia*. The size of the plasmodium varies from a ten-cent piece to several square feet of surface. It is net-like, the net being of irregular dimensions. Like the amœba the outer portion of the plasmodium is clear and

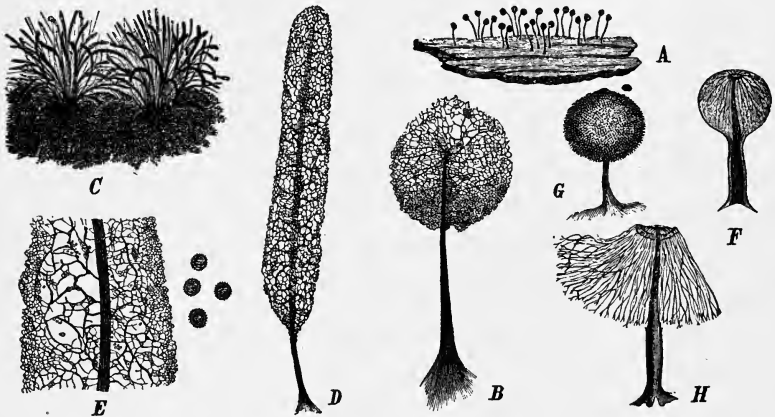

FIG. III.—A, B, *Comatricha nigra*. A, Sporangium, natural size; B, capillitium, 20/1; C, E, *Stemonitis fusca*; C, sporangium, natural size; D and E, capillitia, 5/1, 20/1; F, H, *Enderthema papillatum*, F, unripe; G, mature sporangium, 10/1; H, capillitium, 20/1. (C, D, after nature. A, F, G, H, after Rostafinski; B, E, after de Bary in *Die natürlichen Pflanzenfamilien* I. 1, p. 26.)

watery and known as the *ectoplasm*, the inner portion is granular and called the *endoplasm*. Like the amœba and unlike other plants, this slimy body engulfs solid food by means of its pseudopodia instead of admitting it in solution. It is extremely sensitive to light being negatively heliotropic, *i.e.*, turning away from the sun's rays. At the time of reproduction, the plasmodium creeps to the surface. The whole plasmodium then forms one or more fructifications. These fructifications vary from cushion-like masses (*æthallia*)

to more elevated bodies in which the net-like structure of the plasmodium is preserved (*plasmodiocarps*) to stalked *sporangia* (spore cases). All of the fructifications, however, produce *spores*. During wet weather amœboid protoplasts (*swarm spores*) escape from the spores, each developing a single *cilium* and moving actively about. In time the cilia disappear and these swarm spores coalesce in smaller than larger groups to form a plasmodium.

### SUBDIVISION III.—ALGÆ

Low forms of thallophytes of terrestrial and aquatic distribution consisting for the most part of single cells or rows of single cells joined end to end to form filaments. The higher forms, however, possess structures, which might be compared to stems and leaves of higher plants although more rudimentary in structure. They contain chlorophyll or some other pigment, and so can use the  $\text{CO}_2$  and  $\text{H}_2\text{O}$  in the same manner as higher plants, *e.g.*, in assimilating and providing for their own nutrition. Archeogonia are absent in this group.

### CLASS I.—CHLOROPHYCEÆ, THE GREEN ALGÆ

Green algæ are unicellular (sometimes motile), filamentous, colonial, or sheet-like water plants characterized by the presence of solitary, or numerous chloroplasts in the cells, which compose the thallus. These chloroplasts vary considerably in form, being in some cases spiral bands, in other star-shaped, in others like a napkin ring, and in others granular. In the chloroplasts of most green algæ are pyrenoids, which consist of a central crystalline portion of protein (aleurone-like) surrounded by a starchy envelope of variable magnitude. These are called starch centers and the starch is frequently in the form of rounded, or angular grains. The nutrition of these algæ is autotrophic. There is a definite nucleus present, but in the coenocytic forms the nuclei may be many within the confines of the cell wall. The motile cells have one to many cilia, as likewise some of the reproductive cells. Reproduction is by cell division, the formation of zoöspores (motile cells), by zygospores

produced by conjugation, by egg cell and sperm cell union (oospores) oogamous reproduction. Green algæ live mostly in fresh water. Some live in brackish water and a few in the sea. Some are associated with fungi to form lichens.

1. **Order Protococcales or One-celled Green Algæ.**—This order contains nearly all of the one-celled green algæ excepting the diatoms and desmids.

**Family Pleurococcaceæ.**—*Pleurococcus vulgaris* is a one-celled green alga, millions of which, living together in colonial fashion, constitute the so-called "green stain" that is common on the north sides of tree trunks, stone walls and fences. Each organism consists of a protoplast surrounded by a cell wall of cellulose. The protoplast contains a chromatophore, cytoplasm and nucleus. Reproduction takes place by the protoplast dividing into two equal parts and laying down a cell wall forming two daughter-protoplasts. These may again divide to form four granddaughter-protoplasts. Still another division may occur as a result of which eight great-granddaughter-protoplasts are formed which frequently adhere to one another forming colonies.

2. **Order Volvocales.**—This order comprises free-swimming aquatic forms whose vegetative cells are bi-ciliated, green, more or less spherical or compressed. Some of the organisms like *Spharella* and *Chlamydomonas* consist of single cells bearing a pair of cilia, while others like *Pandorina*, *Eudorina* and *Volvox* show varying degrees of colony formation. Reproduction sexual or asexual.

*Volvox globator*, a typical representative of this order, is found in fresh water pools as a tiny, hollow, spherical, green colony about  $\frac{1}{50}$  to  $\frac{1}{30}$  of an inch in diameter. When examined under the microscope (Fig. 112), it is found to consist of hundreds of green, more or less spherical cells, united by fine strands of cytoplasm (protoplasmic bridges), the whole being enveloped by a gelatinous sheath. The peripheral cells are provided with cilia, in order that the colony may rotate and roll through the water. In a young colony, all of the cells are alike, each consisting of a mucilaginous-like cell-wall enclosing cytoplasm, a nucleus, a chloroplast and often a red pigment spot. In a mature colony, however, throughout the greater part of its existence, two kinds of cells may be discerned:

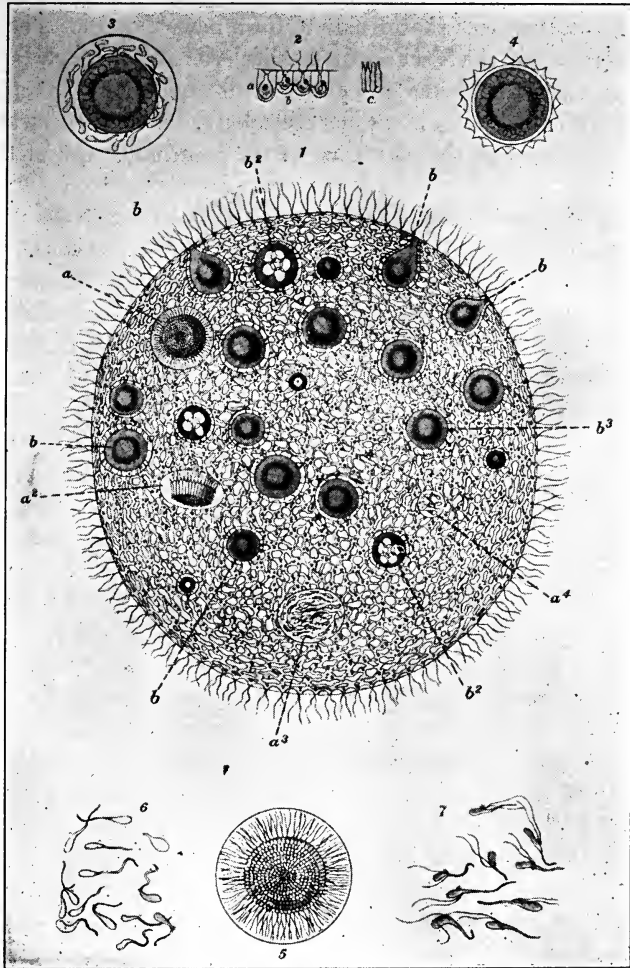

FIG. 112.—*Volvox globator*. Mature colony in center (1); sexual cells (2a); endochrome of primary cell has resolved itself into a cluster of secondary cells (1a, a<sup>2</sup> and 5); antherozoids (6, 7); bundle separated into component antherozoids in cavity of primary cell (1a<sup>3</sup>); breaking of wall of primary cell showing escape of antherozoids into cavity of volvox sphere (1a<sup>4</sup>); egg cells (1b, b); flask shaped germ (egg) cells with large vacuoles in protoplasm (1b<sup>2</sup>, b<sup>2</sup>); globular egg cell prepared to pass into cavity of volvox sphere (b<sup>3</sup>); antherozoids collected about egg cell (3); oöspore (4). (Carpenter.)

small, sterile, vegetative cells that do not divide and from 10 to 12 larger vegetative ones that divide to form new colonies. The latter slip inward below the level of the smaller cells and through repeated divisions form a number of ciliated cells jointed by cytoplasmic threads, which in reality is a miniature colony. This then escapes to the exterior through the rupturing of the gelatinous wall of the old colony.

During autumn of the year, certain of the ordinary cells undergo differentiation, some to form sperm cells, others, egg-cells. When about three times the size of the ordinary sterile cells, the sperm cells divide repeatedly to form a cluster of elongated secondary cells [Fig. 112 (1a, a<sup>2</sup> and 5),] each of which contains an orange colored *endochrome* with a red corpuscle and an elongated beak, bearing a pair of *flagella* (lash-like processes). The cluster in time separates into motile antherozoids [Fig. 112 (6, 7)] which finally escape into the cavity of the volvox sphere through rupture of the investing wall. The flask-shaped egg cells (1b, b) increase greatly in size without dividing. Each shows vacuoles, then becomes filled with a dark green pigment, becomes spherical and acquires a gelatinous envelope. It then passes into the cavity of the sphere where it is surrounded by numerous antherozoids (3) and is finally fertilized.

The product of this fertilization is an oöspore (4) which ere long becomes covered with an internal smooth membrane and a thicker external spinose coat. The chlorophyll within then disappears and starch and a reddish- or orange-colored oil make their appearance. Up to 40 of these oöspores have been observed in a single volvox sphere. Not long after the formation of these oöspores the whole parent colony breaks up and the oöspores fall to the bottom of the pool to pass the winter season. As early as February each oöspore germinates to form another volvox colony, which repeats the life cycle described.

3. **Order Confervales.**—In this order are included a variety of green filamentous and membranous forms some of which show sexual reproduction.

**Family Ulothricaceæ.**—*Ulothrix zonata*, a typical representative of this family, is a filamentous organism found growing on stones around ponds, on rocks along the shores of lakes, in slow-moving



streams, etc. Each filament is unbranched and consists of a row of short cells, one of the terminal cells, called the rhizoid cell, being elongated and serving as an attachment structure. Each cell consists of a cell wall of cellulose enclosing cytoplasm, a nucleus and a wide band-shaped green chromatophore, more or less cylindrical in shape. The chromatophore lies next to the cell wall and contains *pyrenoids* or starch-forming centers. The filament grows in length by the fission of its various component cells. After attaining a certain size it reproduces either asexually or sexually. Asexual reproduction takes place by certain cells becoming altered in their protoplasmic contents, through division, to form rounded or pear-shaped *zoöspores*. Each *zoöspore* contains a red pigment spot and

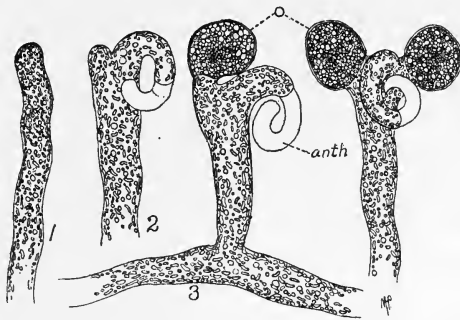

FIG. 113.—*Vaucheria terrestris*. *anth*, antheridium (empty); *o*, oögonia. (Gager.)

bears four cilia (protoplasmic outgrowths). The *zoöspores* escape into the water by lateral openings in the walls of cells containing them. They swim rapidly about, propelled by their cilia, and ere long attach themselves to various objects and grow into *Ulothrix* filaments. The sexual method of reproduction is effected through the production of many *gametes*, in cells of the filament, which resemble the *zoöspores* in shape but differ from them in being smaller and possessing but two cilia. These escape into the water, and, after swimming about for a short time come together in pairs and fuse with one another. The product of the fusion of each pair of these like gametes is termed a *zygospore*. The *zygospore* swims about but finally comes to rest, remaining quiescent for a considerable length of time. It then enlarges and its protoplasmic content

divides to form several zoöspores which, escaping from the cell, swim about for a while and finally, attaching themselves to objects, grow into filamentous *Ulothrix* organisms.

4: **Order Conjugales.**—To this order belong the desmids and pond scums which are distinguished from other green algæ by presenting no motile stages in their life histories. They are all of fresh-water habit and reproduce by conjugation.

**Family Desmidiaceæ.**—The desmid family includes a number of genera of unicellular as well as filamentous green plants that present a variety of shapes. Each unicellular desmid is characterized by being composed of two like halves frequently separated by each other by a constriction called the *isthmus*. In each half there is a *chromatophore* containing *pyrenoids*. The *nucleus* is found in the isthmus. Reproduction is accomplished either asexually by fission or sexually by conjugation.

**Family Zygnemaceæ.**—This is a family of pond scums including the well-known genera, *Spirogyra* and *Zygnema*.

*Spirogyra* or *Brooksilk* is a filamentous organism found suspended or floating in masses in quiet water. Each filament when examined microscopically will be found to consist of more or less elongated cylindrical cells arranged end to end, the terminal cells having rounded extremities. Each cell has a cell wall of cellulose within which is to be found a thin film of *ectoplasm*. One or more spirally shaped *chromatophores* will be seen directly within this area. Each chromatophore contains *chlorophyll* and a number of *pyrenoids*. In the center of the cell the *nucleus* is found. Fine strands of protoplasm hold it in place and run out to the ectoplasm.

Under favorable circumstances the cells of *Spirogyra* increase rather rapidly in length. Abnormally long cells are not seen, however, because the elongating cells speedily divide, forming two daughter-cells. Under the best of conditions, division may occur every night. In this way the filaments are rapidly made longer. Sooner or later they break and in this way the plant multiplies.

*Spirogyra* has also a process of sexual reproduction known as conjugation. This process occurs normally from March to June and July, but can be induced in the laboratory by allowing the water in the vessel in which it is growing to slowly evaporate. Two fila-

ments arrange themselves side by side, and the cells lying opposite each other undergo internal changes so as to form *gametes* or sexual cells. Each protrudes a process or *conjugation tube*; these unite

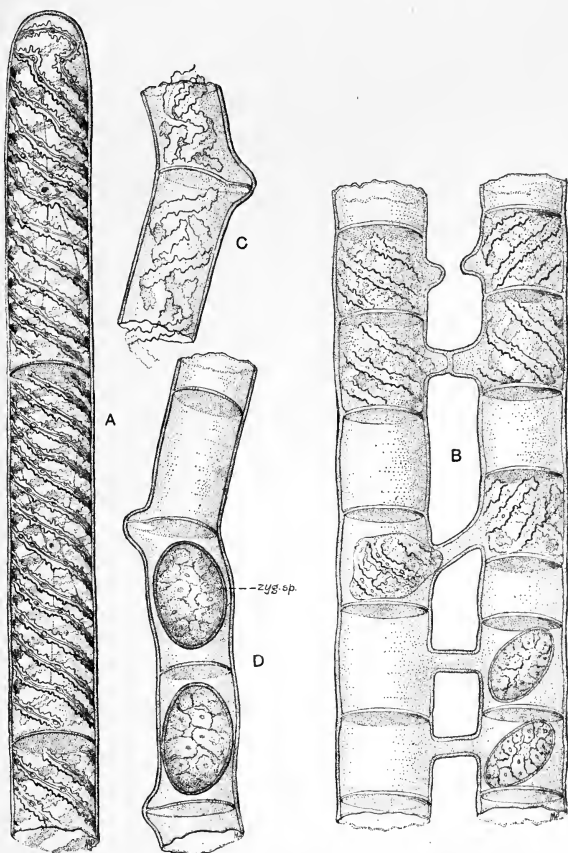

FIG. 114.—*Spirogyra* sp. A, terminal portion of vegetative filament; B, stages of scalariform conjugation; C, preparation for lateral conjugation; D, zygospores formed by lateral conjugation. (Gager.)

and the protoplasm from one cell passes over and coalesces with that in the cell opposite. The result of the process is a new cell called a *zygospore* or *zygote*. This is set free by decay of the walls of the old

cell and falls to the bottom of the water, there to undergo a resting stage until favorable conditions for growth arise.

5. **Order Diatomales.**—**Family Diatomaceæ.**—This family comprises several thousand species of unicellular plants called *Diatoms* which are found in fresh, brackish and salt water, forming much of the diet of small animals. While unicellular, they frequently are united in colonies. They all possess chromatophores containing

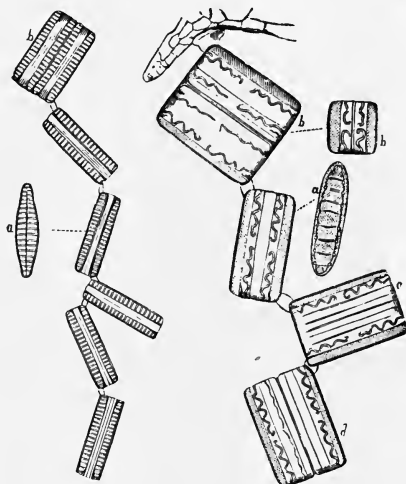

FIG. 115.—Two species of Diatoms. To left, *Diatoma vulgare*; a, side view of frustule; b, frustule undergoing division. To right, *Grammatophora serpentina*: a, front and side views of single frustule; b, b, front and end views of divided frustule; c, frustule about to undergo division; d, frustule completely divided. (After Carpenter.)

chlorophyll but this green pigment is often obscured by the presence also of a brown pigment.

The most striking peculiarity of the group is the structure of the enclosing cell wall. This is in the form of a siliceous case consisting of two *valves* which fit into each other like the halves of a pill box. The valves, which are beautifully sculptured, are similar except that one is slightly larger than the other so as to fit over it. Diatoms vary in form being either circular, linear, elliptical, cylindrical, rhomboidal, triangular or fan-shaped, etc. Some are borne on the

ends of stalks, while others are held in gelatinous masses. Their siliceous skeleta are deposited constantly on the floor of ponds, rivers, lakes and seas, often in such abundance as to form Diatomaceous earths or Kieselguhrs (Siliceous Earths). Huge geological deposits of this material have been found in various parts of the world. The most remarkable for extent as well as for the number and beauty of the species contained in it is that at Richmond, Virginia. It is in many places 25 to 40 feet in depth and extends for many miles.

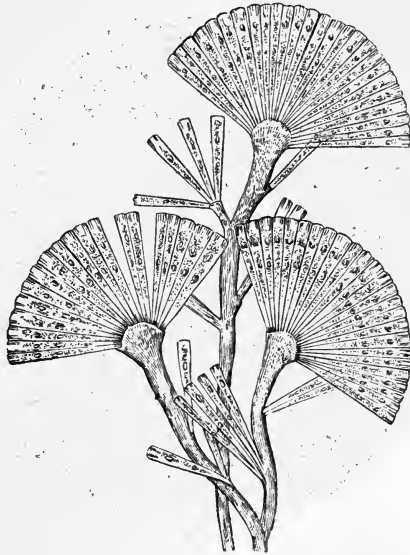

FIG. 116.—*Lismophora flabellata*, a diatom with wedge-shaped frustules borne on the ends of stalks, producing a fan-like arrangement. (After Carpenter.)

Many of the diatomaceous earths are useful as absorbent and polishing powders. The United States Pharmacopœia IX recognizes, under the name of *Terra Silicea Purificata* (Purified Siliceous Earth), a powder consisting of the frustules and fragments of diatoms which has been purified by boiling with diluted hydrochloric acid, washed and calcined.

*Diatoms* exhibit two modes of reproduction; viz., fission and formation of an *auxospore*. The more common method is that of

fission but this is peculiar for these plants. The cell-contents within the siliceous case separate into two distinct masses and the valves separate slightly from each other. As the two daughter-masses become more and more developed, the valves of the parent-cell are pushed more widely apart. Each of the two masses secretes for itself a new valve on the side opposite to the original valve. When the process is completed the girdle of the parent-diatom separates



FIG. 117.—Fossil diatoms: *a, a, a*, *Gaillonella procera* and *G. granulata*; *b, b*, *Surirella plicata*; *c*, *Surirella craticula*; *d, d, d*, *Gaillonella (Melosira) biseriata* (side view); *e*, *Gomphonema gracile*; *f*, *Cocconema fusidium*; *g*, *Tabellaria vulgaris*; *h*, *Pinnularia dactylus*; *i*, *Pinnularia nobilis*; *k*, *Surirella caledonica*; *l*, *Synedra ulna*. (After Carpenter.)

and the two daughter-diatoms thus become independent plants. Each of these possesses one of the parent valves and a second, which it has formed itself more or less parallel to the first.

In a number of species, repeated fission results in the formation of succeedingly smaller and weaker individuals. This process, however, goes on only for a certain number of generations until the decrease of size has reached a limit for the species, when the

plant is rejuvenated by the formation of an *auxospore*. This may be formed with or without the conjugation of two parent-protoplasts. In either case the auxospore resulting undergoes a resting stage after which it develops new valves. The newly formed diatom is then several times the size of the individual or individuals which contributed to its formation and is endowed with renewed vigor for growth and division.

6. **Order Siphonales** (*Siphon Algæ*).—This group is characterized by the peculiarity that the organisms constituting it possess protoplasm containing myriads of nuclei within a common filament or cell cavity not segmented by cell walls. The term *canocyte* has been given to such structures which consist of a many-nucleated mass of protoplasm surrounded by a cell wall. Some of the siphon algæ reproduce by zoöspore formation, others by conjugation as well as zoöspore formation while *Vaucheria*, the green felt, stands out alone in reproducing both by the formation of a single zoöspore and by the production also of *oögonia* and *antheridia* with resultant fertilization. (Fig. 113).

7. **Order Charales** (*The Stoneworts*).—**Family Characeæ**.—The highest group of algæ, possessing forms which are differentiated into stems, leaves and rhizoids.

*Chara*, a type of this family, is a submerged fresh-water plant which fastens itself to the muddy bottom of ponds, ditches and slow streams by means of slender filaments called rhizoids. From these there arises a many noded (jointed) stem which bears whorls of slender green leaves at its nodes. Branches are also found issuing from some of the nodes which duplicate in appearance the main stem. Reproduction is either asexual or sexual. Asexual reproduction is accomplished by means of tuber-like bodies borne on submerged parts or by special branches which form *rhizoids* on their lower nodes and later become separated from the parent plant. Sexual reproduction is effected through the formation of *oögonia* (female sex organs) and *antheridia* (male sex organs). These in some species are borne on the same plant; in others, on different plants. In all cases the sexual organs are produced at the nodes. The oögonium develops within itself a large *ovum* or egg. The antheridium produces within its wall numerous motile sperms.

Upon the maturation of the antheridium the sperms are liberated into the water, and, propelled by their cilia, find their way to the oögonia which they enter, the one best adapted fusing with the egg in each case and fertilizing it. The resultant cell is called the *oöspore*. This undergoes a resting stage and later germinates as a *proembryo*. The proembryo consists of a simple filament and a long rhizoidal cell. From this proembryo, the adult stem arises as a side branch.

## CLASS II.—PHAEOPHYCÆ, THE BROWN ALGÆ

Mostly marine forms showing great diversity in the form of their vegetative bodies. They occur for the most part in salt water between the high and low tide marks. Their bodies are usually fixed to some support in the water by means of a holdfast, and are often highly differentiated both as to form and tissues. Some reach hundreds of feet in length as, for example, *Macrocystis* which grows in the Pacific Ocean off the coast of California. They all contain the brown pigment called *phycophæin* and the green pigment, *chlorophyll* both of which are present in their chromatophores. A yellowish pigment called *phycoxanthin* has also been isolated from some of the species. Many of the kelps and rockweeds belonging to this class have long been sources of iodine, potash and sodium.

**A Filamentous Brown Alga, *Ectocarpus Siliculosus*.**—*Ectocarpus* occurs as tufts of branching filaments, each of which is many-celled. These tufts are found on eelgrass or other algæ as well as attached to pilings of wharves in salt water. It is a striking illustration of the simplest form of brown algæ and serves to show the beginning of a more complex form of reproduction than that observed in the forms studied up to this time. On examination of a filament we find it to consist of many cells joined end to end. A single cell has a cell wall of cellulose. Just within the cell wall there is a layer of protoplasm. Going toward the center we find an irregular chromatophore containing a brown pigment called *phycophæin*. From certain cells of the filament spherical *sporangia* (spore cases) arise, which are unicellular. They contain numerous biciliate *zoöspores*, which escape into the sea water, move about and later



develop into new *Ectocarpus* plants. Along the filaments several branches will be seen. Some of these have undergone division into several cells and these again into still smaller cells until many-celled chambers have resulted, which are called *plurilocular sporangia*.

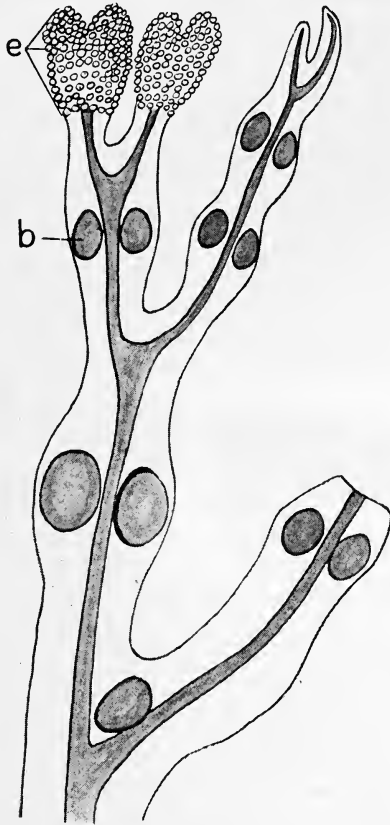

FIG. 118.—End of large branch of *Fucus vesiculosus* (natural size); *e*, receptacle; *b*, air bladder.

Each cell of a plurilocular sporangium contains a *gamete* or sexual cell, which resembles in many details a zoöspore. When the sporangium matures these gametes are discharged into the salt water. They fuse together in pairs and form *zygospores*. Each zygospore

undergoes a resting stage and upon the advent of favorable conditions develops into a new *Ectocarpus* filament.

**Fucus Vesiculosus (The Bladder Wrack).**—This form, a brown alga, occurs as a flat thallus, which forks repeatedly, a type of

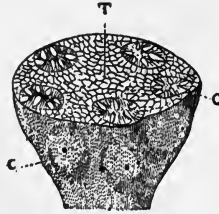

FIG. 119.—*Fucus vesiculosus*. Receptacle cut transversely. *c*, conceptacle, *T*, cellular thickness. (Magnified.)

branching called dichotomous. It grows near the surface of sea water, attached to rocks or to mussels along banks by means of a basal *disc-shaped holdfast*. In the upper branches of the thallus are

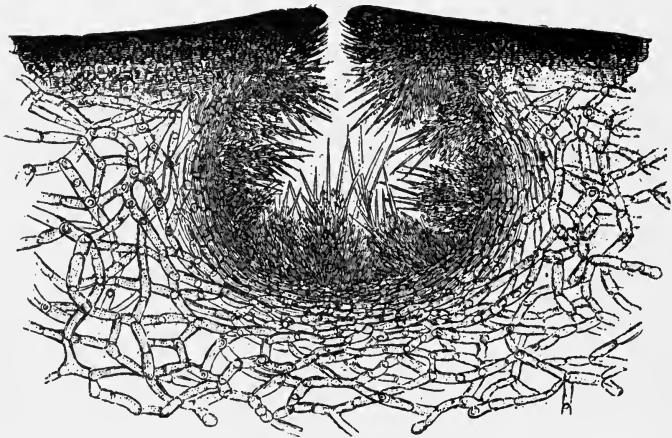

FIG. 120.—*Fucus vesiculosus*. Section of a male conceptacle lined with branched paraphyses which bear the antheridia (highly magnified).

to be found *air bladders* which are more or less spherical and usually in pairs. The tips of old branches become swollen and are termed *receptacles*. They are dotted over with minute cavities called *con-*

*ceptacles*. Within these conceptacles the *antheridia*, or male sexual organs, and the *archegonia*, or female sexual organs, are produced. The conceptacles also contain numerous branching filaments called

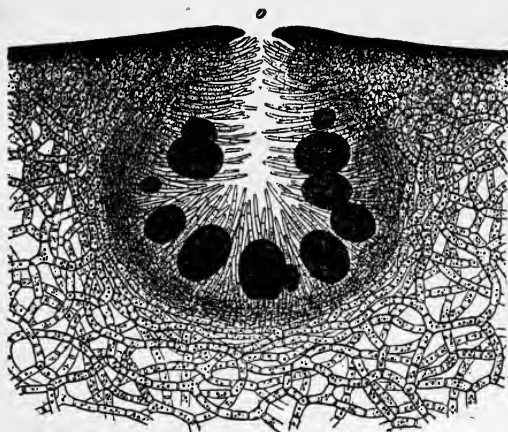

FIG. 121.—*Fucus vesiculosus*. Section of a female conceptacle. *o*, osteole by which the eggs escape. The oval shaped dark objects represent oögonia in different stages of maturity (highly magnified).

*paraphyses*, which arise from the cells lining the cavities. The antheridia are found as outgrowths of these paraphyses and produce *sperms* or male sexual cells. The *oögonium* is a large, globular,

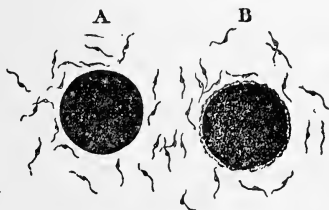

FIG. 122.—*Fucus vesiculosus*. Fertilization. *A*, egg approached by biflagellated sperms; *B*, sperms attached to egg and surrounding it prior to fertilization (highly magnified).

stalked cell and produces eight eggs, each of which is a female sexual cell. The eggs and sperm escape into the sea water. The eggs float and are surrounded by myriads of sperms. One sperm, only,

gains an entrance, after which its nucleus fuses with that of the egg to form an oöspore. The oöspore at once develops into a new *Fucus* plant.

### CLASS III.—RHODOPHYCEÆ, THE RED ALGÆ

A greatly diversified group comprising the majority of marine algæ but represented also by some fresh-water forms. The marine red algæ are generally found at or just beyond the low water mark. Their vegetative bodies vary from simple branching filaments through all gradations to forms differentiated into branching stems, holdfasts and leaves. It has been observed that many of the higher types are composed of numerous filaments which are arranged so closely and connected so intimately by protoplasmic processes as to resemble the tissues of plants higher up. Their color may be red, purple, violet, or reddish-brown or even green and is due to the presence of phycoerythrin, a red pigment, which is found in the chromatophores with but frequently masking the chlorophyll.

*Chondrus crispus* and *Gigartina mamillosa* yield the official drug **Chondrus**, Irish Moss or Carrageen. Both are purplish-red in color. Each consists of a dichotomously branched thallus the lower portion of which is differentiated as a stipe or stalk; the basal portion of which, called the holdfast, clings to the rock. The upper part is several times forked and its terminal segments appear notched or bilobed. Scattered here and there over the segments of the thallus will be noted sporangia which, when mature, contain *tetraspores*. In *Chondrus crispus* the sporangia are elliptical and embedded in the thallus near its surface, whereas in *Gigartina* they are ovate and project outward from the surface of the segments. Upon the ripening of these structures the spores are discharged into the sea water. These sooner or later germinate into new *Chondrus* or *Gogartina* organisms.

The dried mucilaginous substance extracted from *Gracilaria lichenoides*, *Gelidium* and *Gloiopeltis* and other species of red algæ growing in the sea along the eastern coast of Asia constitutes the drug **Agar**, a most valuable ingredient in culture media as well as a laxative.

*Rhodymenia palmata* or Irish Dulse is a purplish-red, flat, membranous, palmately cleft or dichotomous red alga growing on the tissues of other algæ along northern shores of the Atlantic between the low- and high-tide marks.

#### SUBDIVISION IV.—FUNGI

This great assemblage of thallophytes is characterized by the total absence of chlorophyll and so its members possess no independent power of manufacturing food materials such as starches, sugars, etc., from  $\text{CO}_2$  and  $\text{H}_2\text{O}$ . Consequently they are either *parasites*, depending for their nourishment upon other living plants or animals, called *hosts*; or *saprophytes*, depending upon decaying animal or vegetable matter in solution. Some forms are able to live either as saprophytes or parasites while others are restricted to either the parasitic or saprophytic habit. The vegetative body of a fungus is known as a *mycelium*. It consists of interlacing and branching filaments called *hyphæ*, which ramify through decaying matter or invade the tissues of living organisms and derive nourishment therefrom. In the cases of parasites, the absorbing connections which are more or less specialized and definite are called *haustoria*. In the higher forms the hyphæ become consolidated into false tissues, and assume definite shapes according to the species. Of this character are the fructifying organs which constitute the above ground parts of Puff Balls, Cup Fungi, Mushrooms, etc. There are four classes of Fungi, viz.: Phycomycetes, Ascomycetes, Basidiomycetes and Fungi Imperfecti.

#### CLASS I.—PHYCOMYCETES, OR ALGA-LIKE FUNGI

The Phycomycetes represent a small group of fungi showing close affinity with the green algæ. Their mycelium is composed of cœnocytic hyphæ, which suggests a close relation with the Siphonales group of green algæ. Their sexual organs are likewise similar in structure. Transverse septa appear upon the formation of reproductive organs separating these structures from the vegetative hyphæ.

## SUB-CLASS A.—ZYGOMYCETES

(Sexual apparatus shows isogamy)

**Order I.—Mucorales**, the black molds, mostly saprophytic. Examples: *Mucor Mucedo*, *Rhizopus nigricans*, *Thamnidium*, *Pilobolus*.

*Rhizopus nigricans* (Mucor stolonifer), commonly known as "Black Mold" or "Black Bread Mold," is frequently found on bread, jellies, syrups, acetic pharmaceutical extracts and other substrata, where it forms a dense thready *mycelium* bearing numerous black tiny spore cases. The source of this mold is the spores, which are found in the air or water with which the attacked substratum is

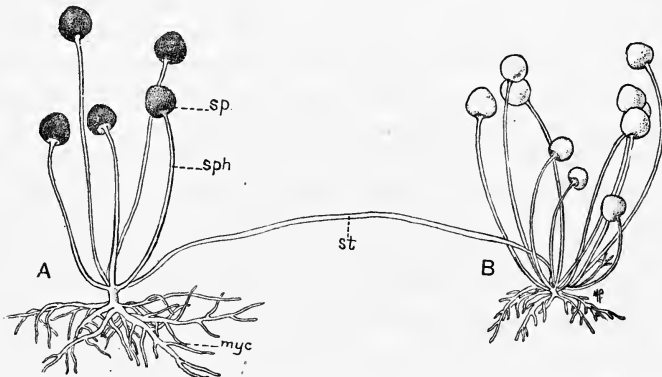

FIG. 123.—Black mold (*Rhizopus nigricans*). A, older plant; *myc*, mycelia; *sph*, sporangiophore; *sp*, sporangium; *st*, stoloniferous hypha produced by A, and giving rise at its tip to a new plant, B. Greatly enlarged. (Gager.)

in contact. Each of these, upon germinating, sprouts out and forms three kinds of hyphæ, viz.: *rhizoidal* or *submerged hyphæ*, *sporangiophores* or *aerial hyphæ* and *stoloniferous hyphæ*. The branching rhizoidal hyphæ penetrate the substratum and secrete a diastatic ferment that changes the water insoluble carbohydrate materials into a soluble sugar which passes into solution and is absorbed by their walls. This, upon entering the hyphæ, is converted into protoplasm, and so the mold increases in size. Sporangiophores or aerial hyphæ arise vertically or obliquely from a bulged-out common base of the rhizoidal hyphæ. Each of these when mature

bears upon its summit a spheroidal *sporangium* containing numerous small brownish multinucleate spores called *endospores*. The wall of the sporangium is beset with asperites of calcium oxalate. Springing from the base of the sporangiophores or aerial hyphæ one or more stoloniferous hyphæ traverse a portion of the surface of the substratum and their tips, coming in contact with the substratum, swell up forming an adhesive organ or *appressorium* which branches out below into a cluster of spreading submerged hyphæ and above into several aerial hyphæ bearing sporangia. This method of growth proceeds until the entire surface of the nutritive medium is covered with a dense fluffy mycelium.

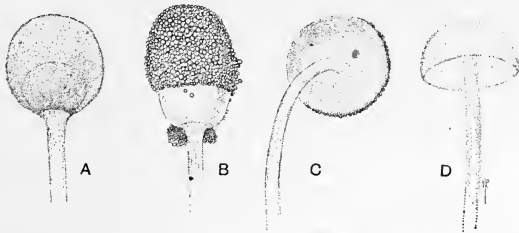

FIG. 124.—*Rhizopus nigricans*. A, Young sporangium, showing columella within; B, older sporangium, with the wall removed, showing ripe spores covering the columella; C, D, views of the collapsed columella after dissemination of the spores. (Gager.)

*Rhizopus* reproduces by two methods. The most common one is that of internal cell formation. In this asexual method a transverse wall is laid down in the sporangiophore near its tip. The terminal cell thus formed swells up, becoming globular in shape and its protoplasmic contents become changed to form numerous spores within the wall of the sporangium or enlarged terminal cell of the sporangiophore. The partition wall, separating the lumen of the sporangium from that of the sporangiophore, bulges into the sporangium as a dome-shaped structure, which is termed the *columella*. Upon the ripening of the spores the wall of the spore case bursts, liberating them. These, falling upon moist nutrient substrata, germinate and ultimately form new *Rhizopus* plants. Under certain conditions *Rhizopus* reproduces sexually. Thicker and shorter club-shaped hyphæ arise on opposite branches of the mycelium. A partition

wall is laid down in each of these a short distance from its tip and the contents of each end-cell then becomes a gamete or sexual cell. The apical cells of the tips of opposite hyphæ then meet, a solution of the cell walls at the point of contact takes place and the gametes of both end-cells fuse to form a *zygospore*. This enlarges and develops a highly resistant wall. After a period of rest, upon coming into contact with a nutrient medium, it germinates into an elongated sporangiophore which develops a sporangium at its summit.

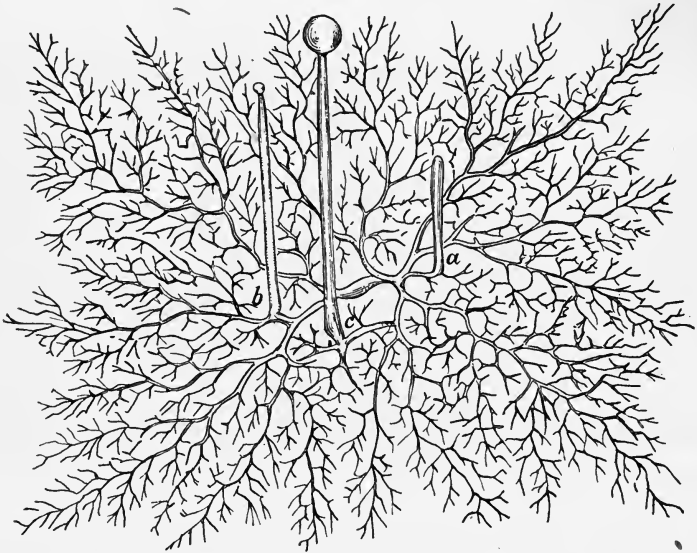

FIG. 125.—*Mucor mucedo*, showing mycelium and sporangiophores. (Palladij.)

*Mucor mucedo*, another closely allied species, found growing on old nuts, fleshy fruits, bread and horse manure, resembles *Rhizopus nigricans* in many respects but differs from it by the formation of sporangiophores singly instead of in clusters.

*Thamnidium* differs from *Rhizopus* and *Mucor* in the development of two kinds of sporangia, *microsporangia* and *megasporangia*. The sporangiophore produces a terminal large megasporangium possessing a columella and whorls of side branches which bear smaller microsporangia in which the columella is frequently wanting.



## SUB-CLASS B.—OÖMYCETES

(Sexual apparatus heterogamous)

**Order 1.—Chytridiales.**—Example: *Synchytrium*, a form parasitic on seed plants and forming blister-like swellings.

**Order 2.—Saprolegniales.**—Water molds which attack fishes, frogs, water insects, and decaying plants and animals. Example: *Saprolegnia*.

**Order 3.—Peronosporales.**—Mildews, destructive parasites, living in the tissues of their hosts and effecting pathologic changes. Example: *Albugo*, the blister blight, a white rust attacking members of the *Cruciferae* and *Phytophthora*, producing potato rot.

## CLASS II.—ASCOMYCETES, THE SAC FUNGI

Mycelium composed of septate filaments and life history characterized by the appearance of a sac called an *ascus* in which *ascospores* are formed. The largest class of fungi.

**Order 1.—Protoascales.**—Plants with asci borne free or at the ends of hyphæ, definite fruiting bodies being absent. Each ascus usually develops four ascospores. To this order belong *Exoascus*, which is responsible for the abnormal development of tufted masses of branches on a number of trees and shrubs, and the *yeasts* (Saccharomycetaceæ) many of which produce fermentation.

**Yeasts** are unicellular plants of spheroidal, oval, elliptical, pyriform or sausage shape which reproduce by budding. They occur either in the wild or cultivated condition and are generally found capable of breaking down some form of sugar into alcohol and carbon dioxide.

According to the kind or kinds of sugar fermented Hansen in 1888 classified the yeasts as follows:

1. Species which ferment dextrose, maltose and saccharose: *Saccharomyces cerevisiæ* I, *S. ellipsoideus* I, *S. ellipsoideus* II, *S. pastorianus* I, *S. pastorianus* II, *S. pastorianus* III.

2. Species which ferment dextrose and saccharose, but not maltose: *Saccharomyces marxianus*, *S. exiguus*, *S. saturanus*, *S. Ludwigii*.

3. Species which ferment dextrose, but neither saccharose nor maltose: *Saccharomyces mali* Duclauxii.

4. Species which ferment dextrose and maltose, but not saccharose: *Saccharomyces* n. sp. obtained from the stomach of the honey-bee.

5. Species which ferment neither maltose, dextrose nor saccharose: *Saccharomyces anomalus* var. *belgicus*, *S. farinosus*, *S. hyalosporus*, *S. membranifaciens*.

The two most important yeasts in the fermentation industries are *Saccharomyces cerevisiæ* and *Saccharomyces ellipsoideus*.

*Saccharomyces cerevisiæ*, commonly called Brewer's Yeast, is a cultivated species with many strains. It is used extensively in the brewing and baking industries and in recent years has met with considerable esteem by the medical profession in the treatment of certain skin diseases.

When examined under the microscope it is found to be somewhat spheroidal to ellipsoidal in outline, 8 to 12 $\mu$  long, and 8 to 10 $\mu$  broad. It consists of an outer cell wall of *fungous cellulose* enclosing cytoplasm and a nucleus, the latter invisible without special staining. The cytoplasm is differentiated into a clear outer membrane lying directly within the cell wall and termed the *ectoplasm* and an inner granular region, the *endoplasm*. In the young condition of the yeast cell numerous glycogen vacuoles are found scattered more or less uniformly throughout this region but as the cell matures these coalesce, until, in a very old cell, a huge glycogen vacuole may be seen occupying most of the interior, with the cytoplasm and nucleus pushed up against the cell wall and forming there a very narrow layer.

Yeast plants grow in dilute saccharine solutions containing dissolved nitrogenous substances such as beerwort, Pasteur's solution, grape juice, etc. Here they are constantly wasting away and as constantly being built up. The question may well arise: "How do they obtain the material necessary for growth and repair?" The answer, in a general way, is not difficult. The fluid in which they live is a solution of sugars and of nitrogenous and other matters. The cell walls are readily permeable. Food substances diffuse through it into the cell, and by a series of changes (which, indeed, it is no easy matter to understand) are converted into new living substance. The waste products likewise diffuse readily outward.

This method of nutrition is called saprophytic, and the yeast plant is said to be a saprophyte.

A striking fact must be briefly mentioned in connection with the metabolism of yeast. Many organisms exercise a profound effect on the medium in which they live. Yeast causes a wholesale destruction of sugar in the surrounding fluid. One of the decomposition

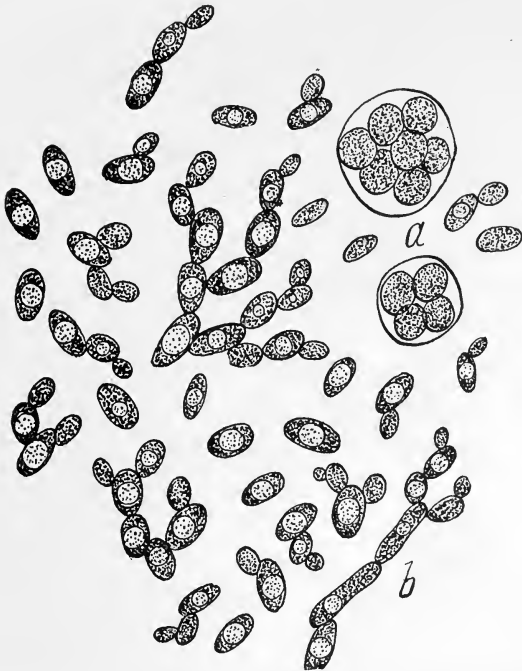

FIG. 126.—Yeast, *Saccharomyces cerevisiae*, the variety known as brewers' bottom yeast; a, spore formation; b, elongated cells. (After Schneider, *Pharmaceutical Bacteriology*.)

products of sugar is alcohol. The alcohol of commerce is produced by the activity of this plant.

*Saccharomyces* has its times of danger and stress when the cells perish in great numbers from cold, starvation, poisons, etc. If not too suddenly exposed, however, they are able to meet adverse conditions by eliminating most of their water, suspending physiological

processes, and becoming dormant. Sometimes they enter the resting condition after a process of division, when each cell divides into four parts, each of which becomes nearly dry and is surrounded by a thick wall. Such cells are called *ascospores*, and their production serves both as a method of multiplying the plant and of tiding over adverse conditions. They can survive for a long time without food or water, and can endure higher temperatures than the active cells and almost any degree of cold.

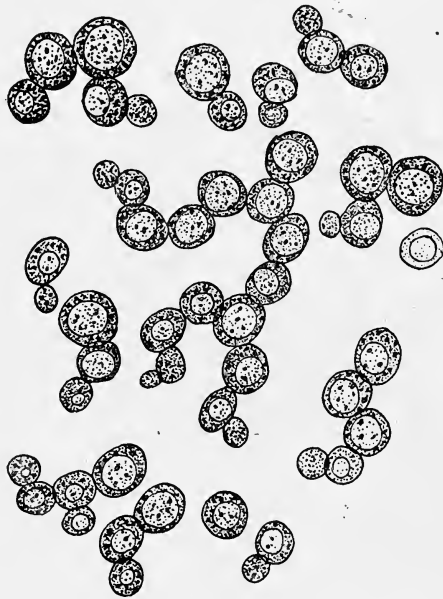

FIG. 127.—*Saccharomyces cerevisiae*. The form or variety known as brewers' top yeast. (*Oberhefe*.)

The dried cells and spores float in the air as dust and so accomplish a dispersal of the organism. Doubtless most of them never again meet suitable environment and so sooner or later perish. But some will fall into favorable conditions and be able to multiply enormously again, and so the species is continued.

The general method of reproduction in *Saccharomyces* is that of *gemination* or *budding*. A small protuberance of the cell wall com-

mences to form on the parent-cell. This grows larger and a portion of the cytoplasm and nuclear material pass into it. Eventually a daughter-bud, which may assume the size of the parent-cell, is formed. This generally adheres to the parent-cell and produces one or more granddaughter-buds which in turn may produce great-granddaughter-buds before separation from the parent-cell takes place.

There are two varieties of brewer's yeast, viz.: Top yeasts and Bottom yeasts. Top yeasts grow on or near the surface of the liquid

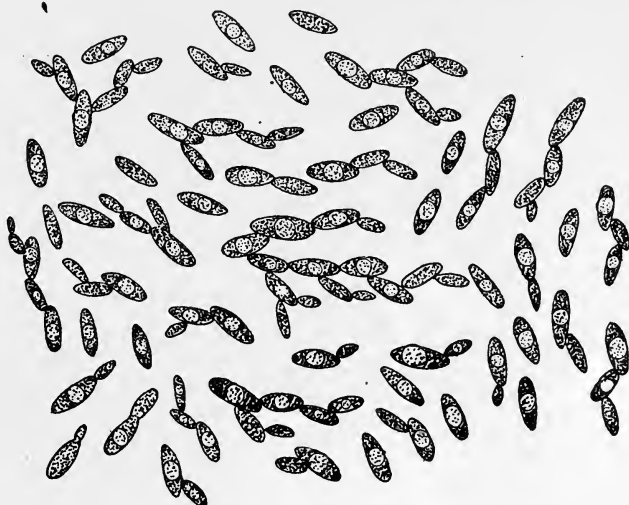

FIG. 128.—*Saccharomyces ellipsoideus*. A common yeast found on grapes, jams, jellies, etc. Budding process is shown in many of the cells as also the vacuoles. (Schneider, *Pharmaceutical Bacteriology*.)

and produce rapid fermentation at summer temperatures causing great quantities of carbon dioxide to arise to the surface and thus forming the froth which is characteristic of ale, stout and porter.

Bottom yeasts grow at about 4°C. at or near the bottom of the vat. They are used in the manufacture of lager beers.

*Compressed yeast* (*Cerevisiæ Fermentum Compressum*) N. F. consists of the moist, living cells of *Saccharomyces cerevisiæ* or of other species of *Saccharomyces*, combined with a starchy or absorbent base.

*Saccharomyces ellipsoideus* is a wild species, several varieties of which are found growing on grapes especially in districts where wine is produced. It is termed the true wine yeast to distinguish it from other wild species found in grape juice, like *S. apiculatus* and *S. membranifaciens* which exert a deleterious effect in wine production. Its cells are ellipsoidal,  $6\mu$  long, occurring singly or in rows of several generations, which are rather loosely joined.

**Order 2.**—**Pezizales** or cup fungi. Examples: *Peziza*, *Lachnea* and *Ascobolus*.

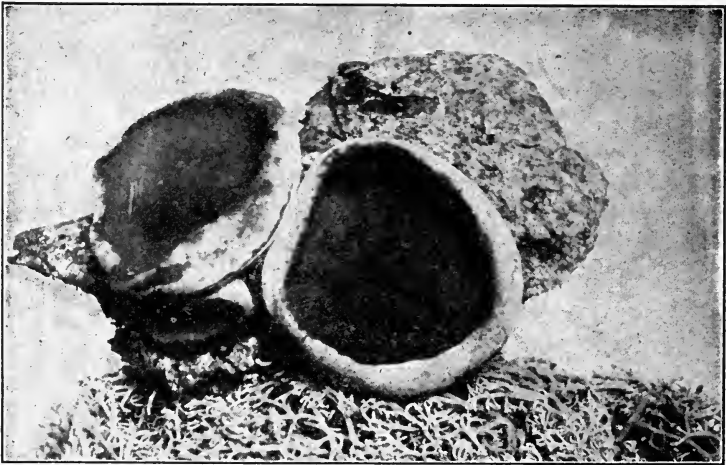

FIG. 129.—Saucer-shaped fruit-bodies of *Peziza repanda*. (Harshberger, from Photo by W. H. Walmsley.)

Parasitic or saprophytic plants, whose vegetative bodies consist of a mycelium ramifying through the substratum and whose above ground fruiting bodies are sessile or stalked, cup or saucer-shaped structure termed *apothecia* (sing. *apothecium*), in which a fruiting membrane (*hymenium*) lines the concave upper surface. The asci are usually eight-spored and separated from each other by filamentous structures called *paraphyses*. (Figs. 129 and 130.)

**Order 3.**—**Plectascales**, the blue and green molds. Examples: *Aspergillus* and *Penicillium*.

**Penicillium glaucum** (green mold or mildew), a type of mildew, belonging to the Ascomycetes class of Fungi, forms sage-green crusts on bread, jellies, old boots, gloves, and various pharmaceutical preparations. It consists of a felt-like mass of interlaced tubular

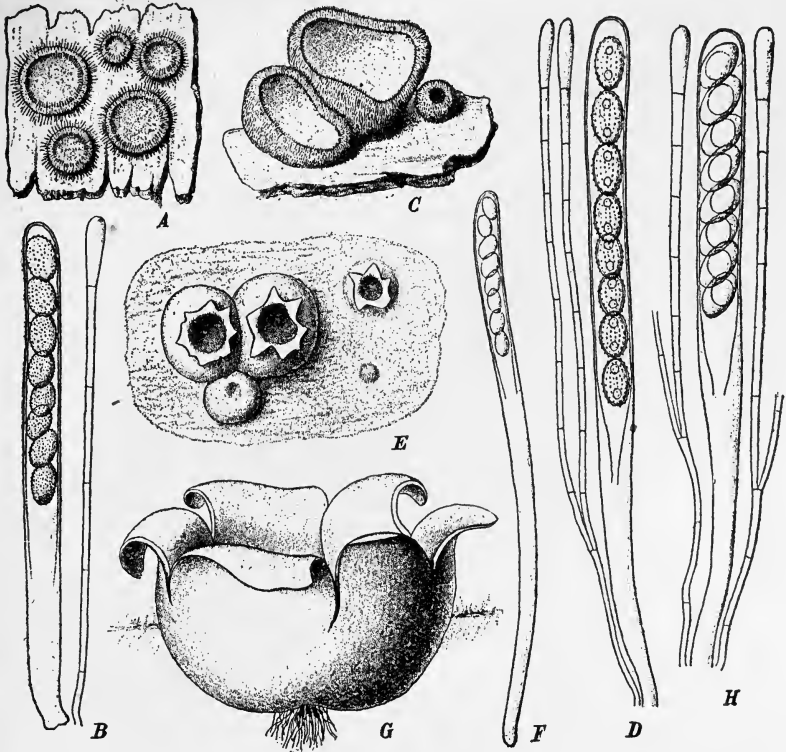

FIG. 130.—A, B, *Lachnea scutellata*. A, Habit; B, ascus with paraphysis; C, D, *Lachnea hemispherica*; C, habit; D, ascus with paraphysis; E, *Sarcosphaera arenosa* habit; F, G, *Sarcosphaera coronaria*; F, ascus; G, habit; H, *Sarcosphaera arenicola* ascus with paraphysis. (See *Die natürlichen Pflanzenfamilien* I, 1, p. 181.) (Harshberger.)

hyphæ called a *mycelium*. From the mycelium numerous hyphæ project into the air and bear a green powder, the spores. These hyphæ are called *aerial hyphæ*. Other hyphæ grow down into the substratum and are called *submerged hyphæ*.

When a small portion of the mycelium is mounted in 10 per cent. alcohol and observed under the high-power objective, it will be noted that each hypha has a transparent wall and protoplasmic contents and is divided by transverse septa into a number of cells. Each cell contains protoplasm, which is differentiated into cytoplasm (cell

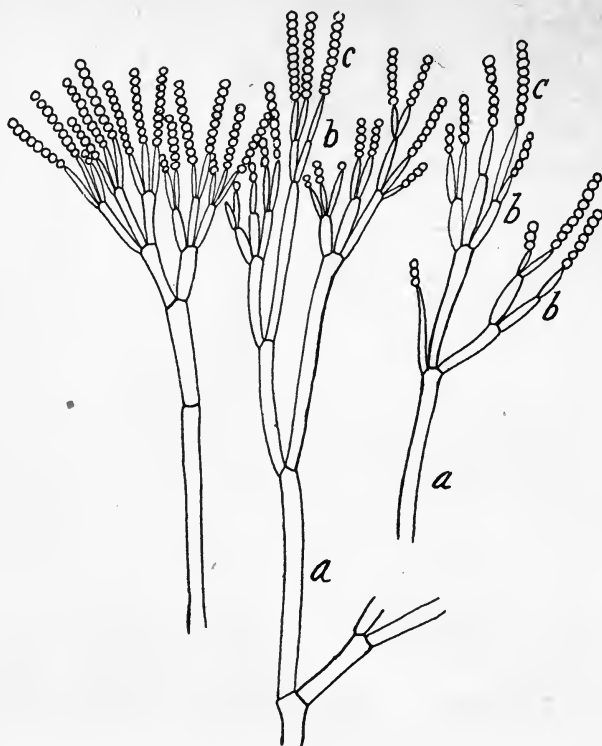

FIG. 131.—Three aerial hyphæ showing the characteristic brush-like branching and spore formation of *Penicillium glaucum*. This fungus is a true saprophyte and is never found on living fruits or vegetables. *a*, Conidiophore branching above into secondary conidiophores; *b*, sterigmata; *c*, conidiospores. (Schneider.)

protoplasm) and several nuclei. In the cytoplasm will be seen several large clear spaces. These are vacuoles and contain water with nutritive substances in solution, called *cell sap*. Each hypha with its branches is clearly distinct from every other one.



The aerial hyphæ bear brush-like branches, which become constricted on their ends into a moniliform aggregation of rounded spores appearing like a row of beads. Each aerial hypha is composed of a vertical septate branch of the mycelium called the *conidiophore*, branches of this, which are called *secondary conidiophores*, and chains of spores at the tips of *sterigmata* (cells bearing conidia) which are called *conidia* or *conidiospores*. The conidia form the loose green powder characteristic of *Penicillium*.

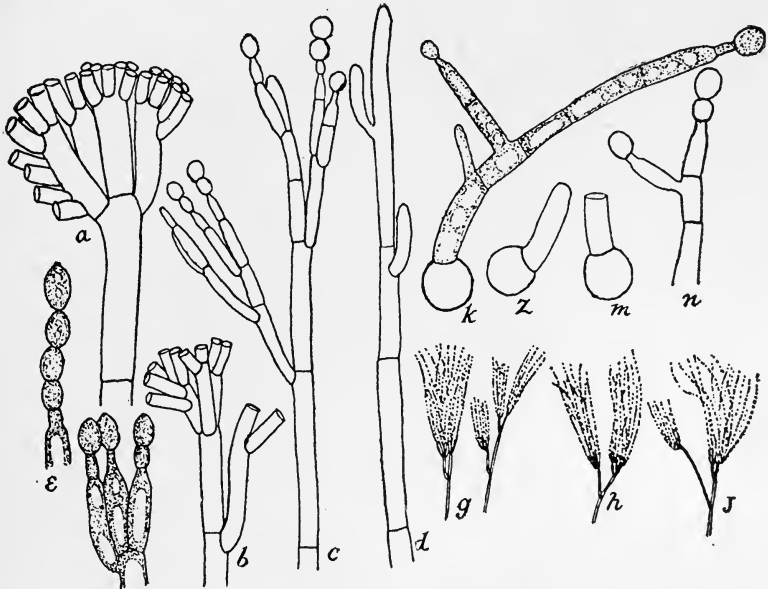

FIG. 132.—*Penicillium Roqueforti*. *a*, Part of a conidiophore; *b*, *c*, other types of branching; *d*, young conidiophore, just branching, *e*, *f*, conidiiferous cells; *g*, *h*, *j*, diagrams of types of fructification. *k*, *l*, *m*, *n*, geminating spores. (After Thom.)

A number of species of *Penicillium* are useful in the arts. *Penicillium roqueforti* is the principal ripening agent of Roquefort, Gorgonzola and Stilton cheeses. It possesses blue-green globular conidia 4 to 5 $\mu$  in diameter.

*Penicillium camemberti* is the principal agent in the ripening of Camembert cheese. It possesses ellipsoidal bluish-green conidia 4.5 to 5.5 $\mu$  in diameter.

*Penicillium brevicaulis* grows on old moist paper and has been used to detect the presence of arsenic, for when grown in media containing this element, it develops the compound, diethylarsine. It is yellowish-brown in color and its conidia are rough and spiny.

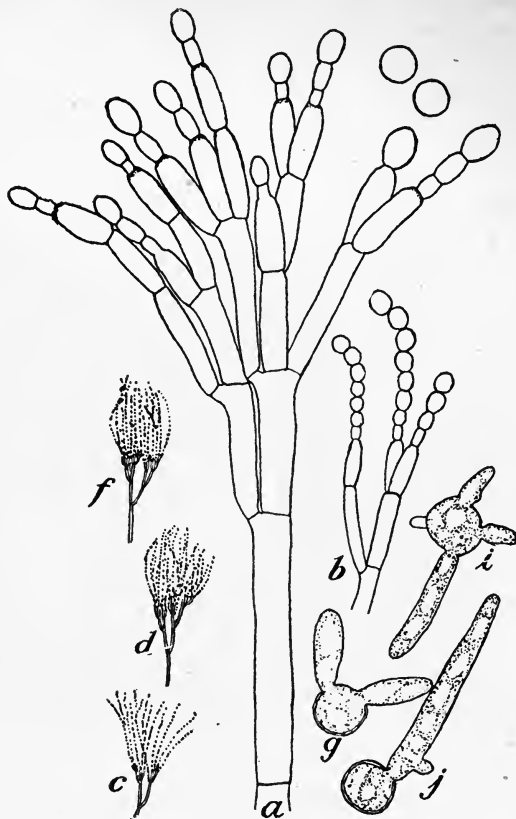

FIG. 133.—*Penicillium Camemberti*. a, Conidiophore with common type of branching with conidiospores; (b), a common less-branched form; c, d, f, diagrams of large fructifications; g, i, j, germinating conidiospores. (From Bull. 82, Bureau of Animal Industry, also After Thom.)

*Penicillium expansum* is often found on decaying apples where it produces brownish coremia.

*Aspergillus herbariorum*.—This green mold also named *Aspergillus glaucus* and *Eurotium Aspergillus glaucus* is frequently found on

fleshy drugs which have not been properly dried. It has also been observed on dried herbarium material, old extracts, on jams, jellies, tobacco, cotton-seed meal, old leather, stale black bread, etc. Like *Penicillium* its vegetative body consists of a mycelium consisting of aerial and submerged hyphæ. It differs from *Penicillium*, however, mainly in not possessing septated conidiophores and by the upper portion of the conidiophores being globular. Upon the globular extremity of the conidiophores are placed numerous elongated sterigmata which bear chains of grayish-green conidia. These are spherical and prickly and range from 7 to  $30\mu$  in diameter. Under certain

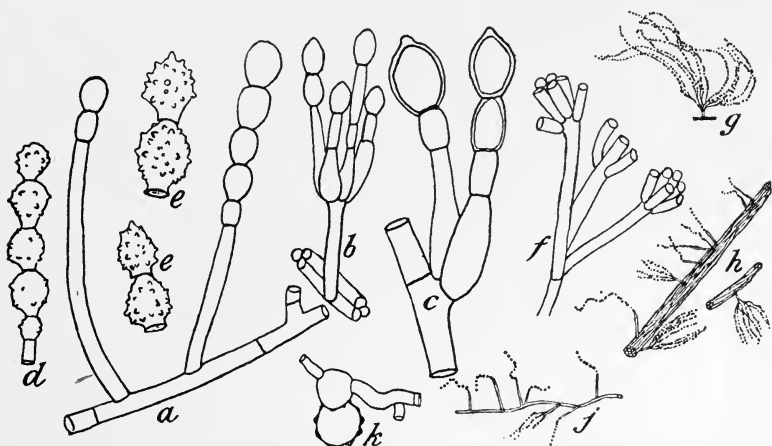

FIG. 134.—*Penicillium brevicaulis*. *a*, Conidiophores and simple chains of conidiospores; *b*, *f*, more complex conidial fructifications; *c*, two young chains of conidiospores; *d*, *e*, echinulate conidiospores; *g*, *h*, *j*, sketches of forms and habits of conidial fructifications; *k*, germinated conidiospores. (After Thom.)

conditions closed brownish fruit bodies called *perithecia* are produced. These arise on the surface of the substratum from spirally coiled hyphæ and when mature possess numerous *asci*, each of which contains five to eight ellipsoidal *ascospores*.

*Aspergillus oryzae* is a yellowish-green to brown mold which secretes diastase, a valuable digestive ferment, having the power of converting starch into sugar and dextrin. For centuries the Japanese have employed this species in the preparation of rice mash for

Saké, as well as in manufacture of Miso and Soja sauce. The spherical conidiospores are 6 to 7 $\mu$  in diameter and of a yellowish-green color.

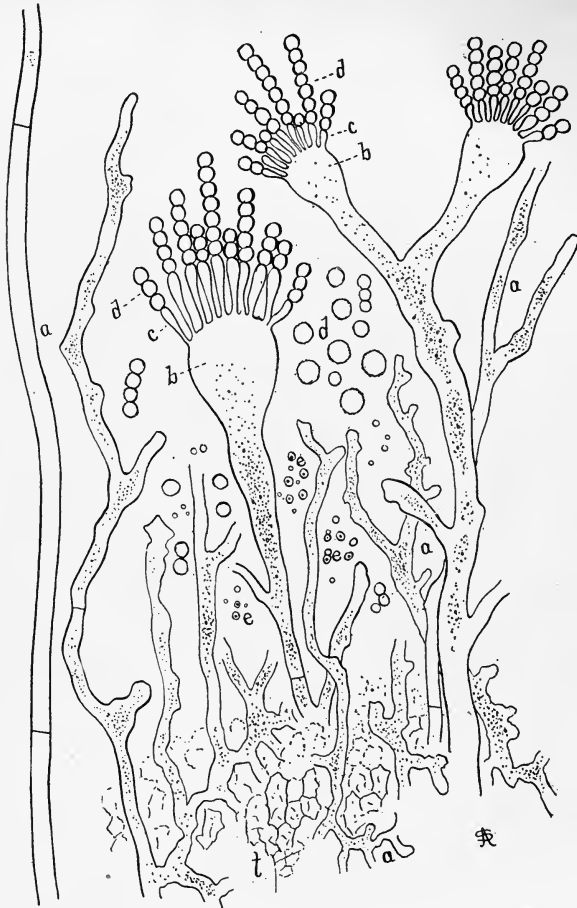

FIG. 135.—*Aspergillus oryzae* associated with yeasts in the making of the Japanese beverage Saké. Vegetative hyphæ (a) and spore-forming hyphæ (b, c, d) are shown. (Schneider, *Pharmaceutical Bacteriology*.)

*Aspergillus fumigatus* is a pathogenic species which produces a disease in birds, horses, cattle and even though rarely in man that is

called aspergillosis. The organ most prone to infection by this organism is the lung, although the skin, cornea, ears and other parts

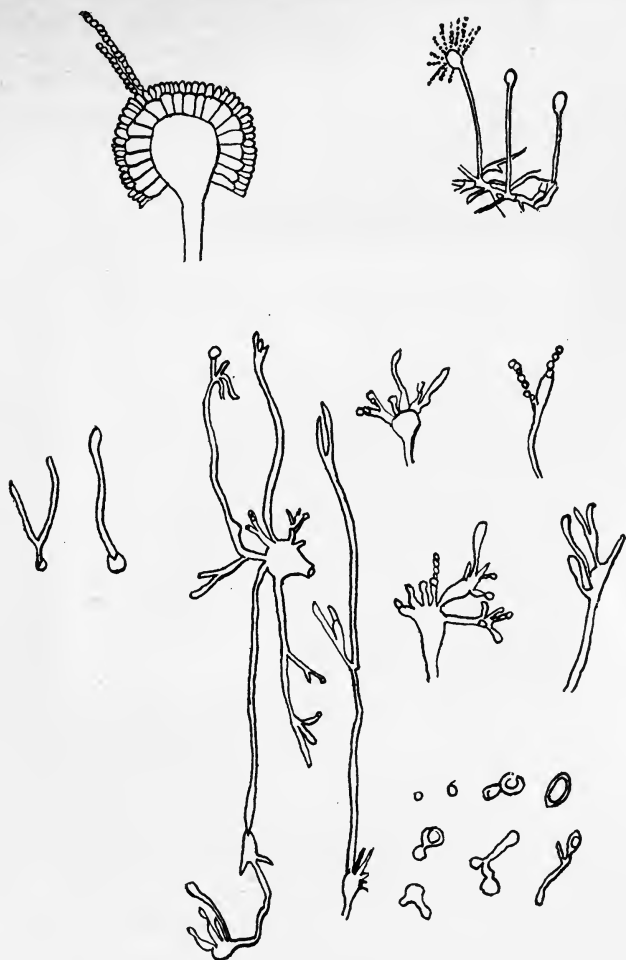

FIG. 136.—*Sterigmatocystis niger* (*Aspergillus niger*) showing conidiophores and conidiospores formation with stages in germination of spores. (Harshberger, after Henri Coupin.)

are also subject to its parasitic influence. It produces short conidiophores with sterigmata bearing long chains of rounded, colorless

conidia 2.5 to 3 $\mu$  in diameter. Harshberger<sup>1</sup> cites the presence of perithecia in this organism which are nut-brown, globular, 250 to 350 $\mu$  in diameter, and inclose oval thin-skinned asci with eight red lenticular ascospores each of which has a diameter of 4 to 5 $\mu$ .

*Aspergillus niger* (*Sterigmatocystis niger*) develops dark brown mycelial masses in which are to be noted slender conidiophores bearing handle-shaped, branched sterigmata that cut off from their tips chains of rounded black-brown conidia 3.5 to 5 $\mu$  in diameter. This fungus has been found to produce suppurative inflammation of the



FIG. 137.—The morel, *Morchella esculenta*. (Gager, from photo by W. A. Merrill.)

external and middle portions of the human ear. It is also a cause of cork disease, so often imparting a disagreeable taste to bottled beverages.

**Order 4.—Tuberales, the truffles.** Fungi whose septate mycelium is often connected with the roots of trees forming the structure known as *mycorrhiza*. Several species of the genus *Tuber* growing in woods of France, Germany and Italy produce tuberous subterranean bodies called Truffles, which are highly prized as a table delicacy by the inhabitants of these countries.

**Order 5.—Helvellales, the saddle fungi.** Fleshy fungi entirely

<sup>1</sup>"Mycology and Plant Pathology" p. 147.

saprophytic, living attached to leaf mold or growing in humous soil or, in a few cases, on decaying wood. The fleshy fruiting bodies (ascocarps) are divided into stalk (*stipe*) and cap (*pileus*) portions. The external surface of the cap is covered with a layer of asci and paraphyses which together constitute the ascigeral layer. To this group belong the Morels and the Earth Tongues.

One of the Morels, *Morchella esculenta*, is frequently found in fire-swept woods. Its fruiting body consists of a hollow, externally ridged stipe, bearing upon its summit a fleshy pileus whose outer surface is honeycombed with ridges and depressions. The depressions are covered with an ascigeral layer composed of asci and paraphyses. This species is edible.

**Order 6.—Pyrenomycetales**, the mildews and black fungi common as superficial parasites on various parts of plants. To the black fungi division of this order the Ergot fungus, *Claviceps purpurea* belongs.

**Life History of Claviceps Purpurea.**—Through the agency of winds or insects the spores (ascospores or conidia) of this organism are brought to the young ovaries of the rye (*Secale cereale*). They germinate into long filaments called hyphæ, which, becoming entangled to form a *mycelium*, spread over the ovary, enter it superficially, secrete a ferment, and cause decomposition of its tissue and the resultant formation of a yellow-mucous substance called honey-dew, which surrounds chains of moniliform reproductive bodies known as conidia. The honey-dew attracts certain insects which disseminate the disease to other heads of grain.

The mycelial threads penetrate deeper and deeper into the ovary and soon form a dense tissue which gradually consumes the entire substance of the ovary and hardens into a purple, somewhat curved body called a *sclerotium*, or official ergot—the resting stage of the fungus, *Claviceps*.

The ergot falls to the ground and in the following spring sprouts into several long stalked, globular heads called *stromata* or *ascocarps*. Each (fruiting) head or ascocarp has imbedded in its surface numerous flask-shaped invaginations called *perithecia*, from the bases of which several sacs or *asci* develop. Within each ascus are developed eight filiform spores (*ascospores*) which, when the ascus

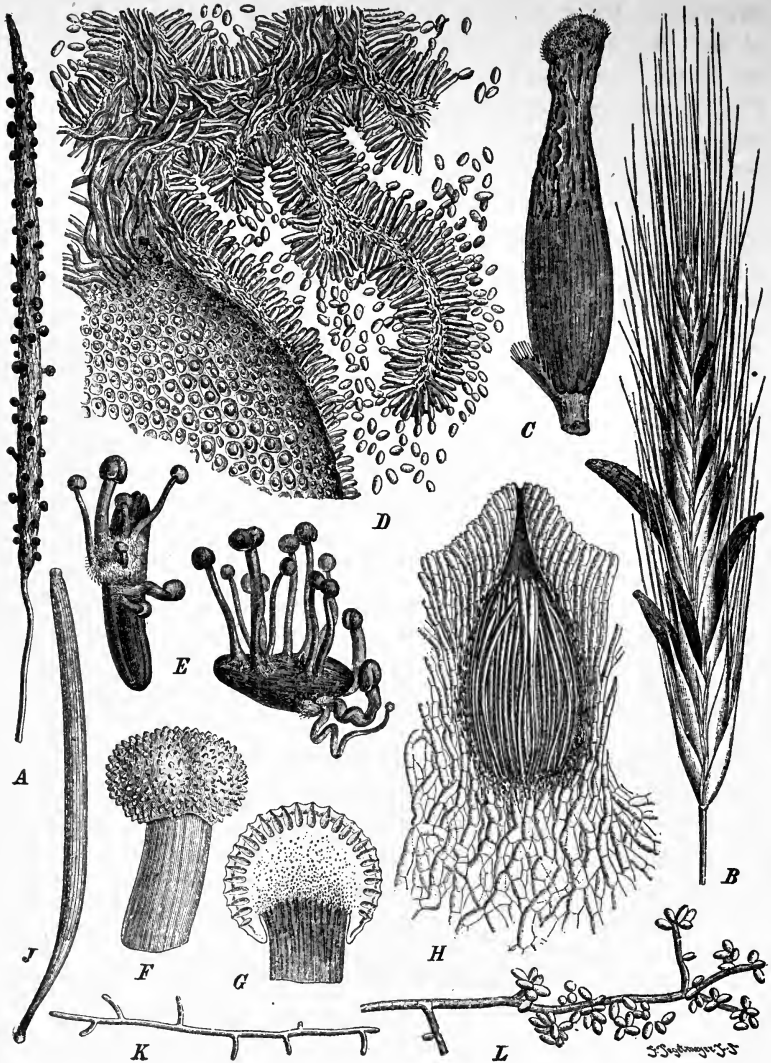

FIG. 138.—A, *Balansia claviceps* on ear of *Paspalum*; B-L, *Claviceps purpurea*; E, sclerotium; C, sclerotium with *Sphaecelia*; D, cross-section of sphaecelial layer; E, sprouting sclerotium; F, head of stroma from sclerotium; G, section of same; H, section of perithecium; J, ascus; K, germinating ascospore; C, conidiospores produced on mycelium. (See *Die natürlichen Pflanzenfamilien I, 1, p. 371.*)



ruptures, are discharged and are carried by the wind to other fields of grain, there to begin over a new life cycle.

### CLASS III.—BASIDIOMYCETES, OR BASIDIA FUNGI

This large class of fungi, including the smuts, rusts, mushrooms, gill and tooth fungi, etc., is characterized by the occurrence of a basidium in the life history. A *basidium* is the swollen end of a hypha consisting of one or four cells and giving rise to branches called sterigmata, each of which cuts off at its tip a spore, called a *basidiospore*. In addition to the basidiospores, some forms also produce spores termed *chlamydo-spores*.

#### SUB-CLASS A.—PROTOBASIDIOMYCETES

(Basidium four-celled, each bearing a spore)

**Order I.—Ustilaginales**, the smuts. Destructive parasites which attack the flowers of various cereals, occasionally other parts of these plants. Example: *Ustilago Maydis*, the corn smut. The basidiospores in this group are borne on *promycelia*.

**Ustilago Maydis (Ustilago Zeæ) (Corn Smut)**.—Corn smut is a destructive parasite which for a long time was supposed to be confined to the Indian Corn, but which now is known to occur on Mexican Grass. It is the only smut useful in medicine. The mycelium of the fungus extends through all parts of the infected host through the intercellular-air-spaces and produces large tumor-like masses on the ears, tassels, husk, leaves and stem. Each mass is filled with spores and covered with a tightly appressed membrane which has a whitish appearance like German silver. The spores are at first a dark olive-green, but on maturity are dark brown. They are sub-spherical and show prominent spines. They arise by the division of the septate mycelium into thick-walled echinulate resting spores called *chlamydo-spores* or *brand spores*. These spores fall to the ground and pass the winter. In the spring each germinates into a three- or four-celled filament called a *promycelium*, from the cells of which *basidiospores* arise. The basidiospores develop a mycelium which penetrates the seedling of the host plant.

Order 2.—Uredinales, the rusts. Obligate parasites possessing a septated branched mycelium which ramifies through the inter-

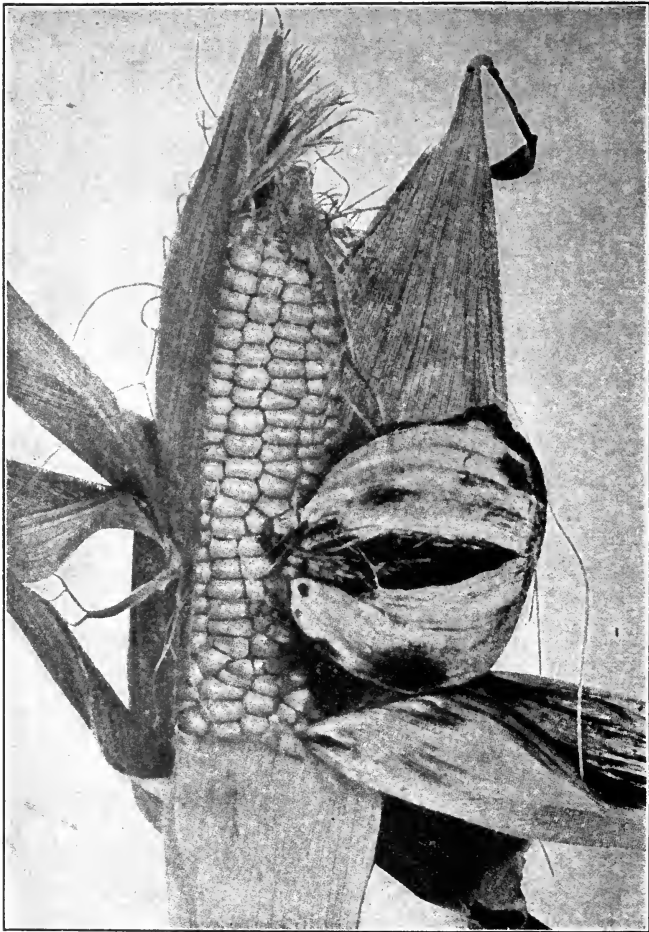

FIG. 139.—Smut boil of *Ustilago zeæ* on ear of corn, developed from one infected kernel. (After Jackson, F. S., Bull. 83, Del. Coll. Agric. Exper. Stat., December, 1908.)

cellular-air-spaces of the host and sends haustoria into the cell cavities. The different stages of their life cycle are either restricted

to one host or distributed between two or more hosts. An outline of the life history of the wheat rust will give an idea of the peculiarities of the group.

**The Wheat Rust (*Puccinia Graminis*).**—If we examine the wheat plant just before harvest we will find on the stems and leaves

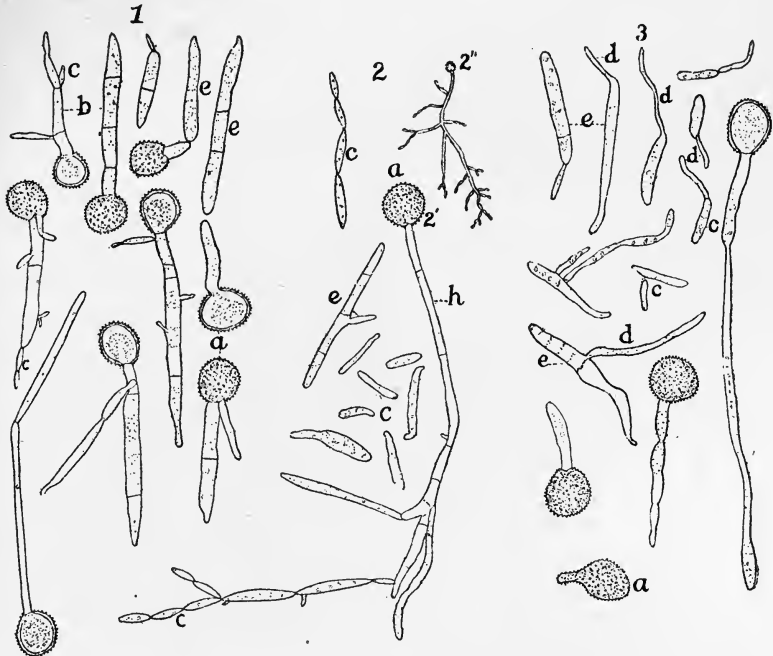

FIG. 140.—Germination of the chlamydospores of corn smut (*Ustilago zeae*); 1, Various stages in germination from corn 3 days after being placed in water; 2, spores germinated in contact with air; 3, several days after spores were placed in  $\frac{1}{20}$  per cent. acetic acid, formation of infection threads. a, Spores; b, promycelia; c, basidiospores; d, infection threads; e, detached pieces of mycelia. (After Bull. 57, Univ. Ill. Agric. Exper. Stat., March, 1900.)

some rust-red lines. The presence of the mycelium of the fungus in the intercellular spaces of the host does not kill the host directly or appear to stunt its growth, but the effect of the parasite on the host is seen when the grains mature. The grains are small and mushy, due to the fact that the nutrition of the host had been disturbed and the formation of starch in the grains inhibited. The

mycelium is localized and gives rise underneath the epidermis to rounded egg-shaped spores attached to it by short pedicels. The spores are produced in such numbers that the space beneath is too confined. As the long epidermal cells of grasses run longitudinally, the pressure of the spore masses from within causes the epidermis to crack and its edges become turned back. Through the resultant cleft the *summer spores* or *uredospores* are thrust out. These uredospores are orange-brown in color and covered with minute spines. The mass of them has been called a *uredinium*. These spores are

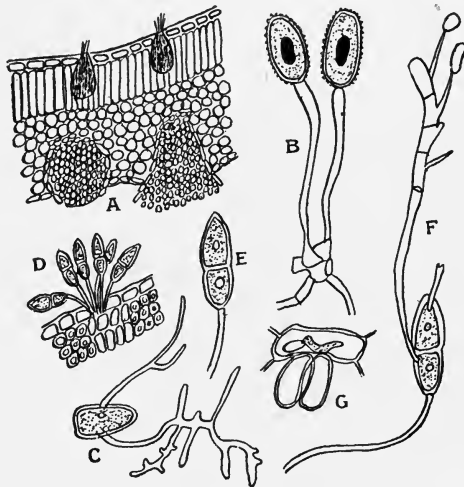

FIG. 141.—Spore forms of wheat rust, *Puccinia graminis*. A, Section through barberry leaf showing pycnia on upper surface and aecia on lower; B, two uredinio spores; C, germinating urediniospore; D, teliosorus showing several teliospores; E, single two-celled teliospore; F, germinating teliospore with four-celled basidium and two basidiospores; G, basidiospore growing on barberry leaf. (Harshberger, adapted from deBary.)

detached from the pedicels and blown by the wind to healthy plants. After summer is over and dry weather comes on, an examination of stubble in the field (blades of grass and stems of wheat left carelessly), these rust-red lines are replaced by brownish-black spores called *teleutospores* (teliospores). A mass of these is known as a telium.

The summer stage on wheat is known as *Uredo linearis*.

The autumn stage on wheat is known as *Puccinia graminis*.

The teleutospores are two-celled and have thick walls and persistent pedicels. They remain attached to the stubble until the following spring and then either one or both cells composing them produce an outgrowth known as a promycelium (nothing but a basidium divided transversely into four cells). Each cell of the basidium is capable of producing a branch, at the tip of which a basidiospore is formed. These basidiospores are blown to the Barberry (*Berberis*) and infect the leaves of this plant. The mycelium runs in the intercellular-air-spaces and causes the appearance of a number of small depressions on the upper side of the leaf. These in section are a rich chocolate brown and known as *spermagonia*. In the center of a spermagonium are produced hyphæ, which project out to its orifice and obstruct off minute spores called *spermacia*. On the opposite side of the leaf cup-shaped depressions are formed, each with a limiting membrane (peridium). Within the cup-shaped depression thousands of spores are formed in chains closely packed together. These are the æcidiospores (æciospores). The cluster cup is called an *Æcidium* (*Æcium*). These æciospores are conveyed to wheat and cause infection, thus completing the life cycle. It has been observed that in America the uredospores or summer spores may winter over and infect healthy plants, so that the Barberry phase is completely eliminated from the life cycle.

**Order 3.—Auriculariales.**—The so-called “ear fungi” which occur on the bark of many plants, on wooden fences, etc., as auriculate growths which when young are jelly-like and brilliantly colored, when old, hard, grayish and considerably wrinkled. The ear-like fruiting body is known as the *sporophore*. Its internal surface is lined with a hymenium or fruiting body consisting of numerous four-celled basidia, each of which cuts off at its tip a basidiospore.

**Order 4.—Tremellales.**—Saprophytes which live on decaying wood as moist, soft, quivering, gelatinous growths becoming later dry and horny.

#### SUB-CLASS B.—AUTOBASIDIOMYCETES

(Mostly fleshy forms characterized by one-celled basidia with generally four, occasionally six, eight or two sterigmata each of which cuts off a basidiospore at its tip.)

## Division a.—Hymenomycetes

(Hymenium or spore-bearing surface exposed)

This division of Autobasidiomycete or higher basidiomycete fungi comprises the following orders: Dacromycetales, Exobasidiales, Thelephorales, Clavariales and Agaricales.

**Order 1.—Dacromycetales.**—This order includes the “weeping fungi.” One of the most common is *Dacromyces deliquescens* which

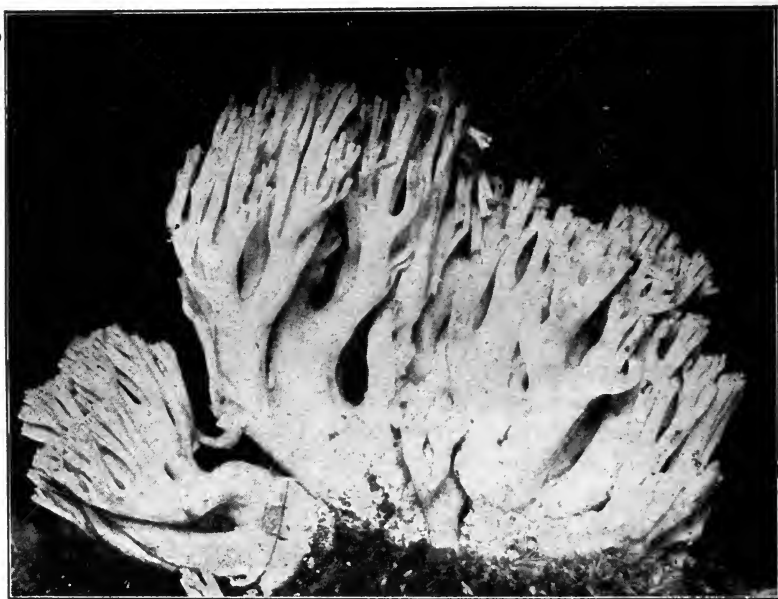

FIG. 142.—Coral-like fruit-bodies of *Clavaria flava*. (Harshberger, from Photo by W. H. Walmsley.)

occurs as a gelatinous body of bright red color on dead wood. The basidiospores are formed during a wet period and the fungus swells up in the water forming a slimy mass. In addition to basidiospores the mycelium may break up into oidiospores, if the wet period is prolonged. In consisting of slimy gelatinous masses the “weeping fungi” approach the *Tremellaceae* but are distinguished from them

in the basidium being undivided in the former and divided in the latter.

**Order 2.—Exobasidiales.**—This group is found growing parasitically on shrubs especially those of the heath family. The mycelium lives in the tissues of the stems, leaves, sepals and petals and produces spongy fleshy yellowish or brownish galls which are popularly called "Azalea apples." The galls are edible. They are covered with a hymenium.



FIG. 143.—*Boletus felleus* in three stages of development. (After Patterson, *Flora W. and Charles, Vera K.*, Bull. 175, U. S. Dept. Agric., pl. xxxi, Apr. 29, 1915.)

**Order 3.—Thelephorales**, forms appearing on tree trunks as leathery incrustations or as bracts on the ground, old logs, etc.

**Order 4.—Clavariales**, the coral or fairy club fungi. Fleshy coral or club-shaped forms, all of which are saprophytes found in woods growing in bunches out of leaf mold. They are all edible and of a white, yellow or some other brilliant color. (See fig. 142.)

**Order 5.—Agaricales**, the mushroom or toadstool alliance. Alike with the other members of the Basidiomycetes, the plant body consists of the mycelium, ramifying through the substratum, but the part which rises above the surface (the Sporophore) is in most cases differentiated into a stalk-like body called a stipe bearing upon its summit a cap or pileus, the latter having special surfaces for the hymenium.

**Family I.—Hydnaceæ**, or tooth fungi. This group is characterized by the hymenium being placed over purple-like, spiny or long digitate projections of the pileus. Many of the species of the genus *Hydnum* are edible.

**Family II.—Polyporaceæ**, or pore fungi. The sporophores or fruiting bodies of these fungi are various. They may be entirely supinate with pores or shallow depressions on their upper surfaces (*Merulius*), or mushroom-like (*Boletus*), or of the nature of woody (*Fomes*) or fleshy (*Fistulina*) brackets. In all cases the hymenium or basidial layer lines the inner surface of pores.

The sporophore of *Polyporus officinalis*, when deprived of its outer rind and dried, constitutes the official N.F. drug **AGARICUS**. This species grows abundantly on various species of pines, spruces and larches.

**Family III.—Agaricaceæ**, the gill family, in which the hymenium covers blade-like plates of the pileus, called *gills*, generally occurring on the under surface of the same. Examples: *Agaricus campestris*, the common edible mushroom of fields; *Amanita muscaria* and *Amanita phalloides*, both of which are poisonous.

**Agaricus Campestris (Common Mushroom).**—This plant is an edible gill fungus which grows in open, grassy fields during late summer and early autumn. It is never found in the forest or on trees or fallen trunks, seldom in the mountains. The cultivated form grows in specially constructed houses made of boards. A corridor runs through these houses so that the mushroom beds can be easily reached. In the growth of mushrooms tons of horse manure are used. This is covered with loamy soil  $1\frac{1}{2}$  inches thick. The whole mass is compacted together. Into the resultant beds is introduced English-grown spawn, which comes in flat brick-shaped masses (horse manure through which mycelium has grown). Pieces of these



“bricks” are put in the horse manure bed only after the heat has first disappeared. The beds are then watered well and in a short time the *sporophores* or fruiting bodies of the fungus spring up.

The mycelium or vegetative body of *Agaricus* which develops in the soil from spores (basidiospores) is white and thready. On this mycelium develops little buttons, first about the size of a pin head, becoming later pea size and then assuming a pear-shaped form. At this stage the sporophore consists of a cylindrical solid stipe or stalk and a pileus or cap. The border of the pileus is joined to the stipe



FIG. 144.—Meadow mushroom (*Agaricus campestris* L.). A, view showing under side of pileus; g, gills; a, annulus, or remains of the veil attached to the stipe; B, side view; s, stipe; a, annulus; p, margin of pileus, showing at intervals the remains of the veil. (Gager, after W. A. Murrill.)

by means of a “partial veil.” Within this veil is found a circular cavity, into which the gills grow. At first the stipe grows faster than the rest of the fruiting body. The pileus expands transversely and the gills keep pace. After a while the veil ruptures, leaving a portion attached to the stipe. This constitutes the *annulus* or *ring* (true annulus). The hyphæ in the pileus form the *Tela contexta*. If we make a section through a gill, the hyphæ are seen to run longitudinally. The central part is called the *trama*; next and outside trama is the *sub-hymenium*; next, *hymenium*, consisting of *basidia* (hence a

basidial layer). Each basidium bears one or two little points known as sterigmata. Each sterigma bears a purplish-brown basidiospore. The basidiospores falling to the ground germinate into hyphæ and these become interlaced to form a mycelium.

In the wild mushroom the gills are at first pink, in cultivated, fawn-colored. Ultimately in the wild form the gills turn brownish. The spores are purplish-brown. The color of the stipe and upper surface of the pileus varies from whitish to a drab color.

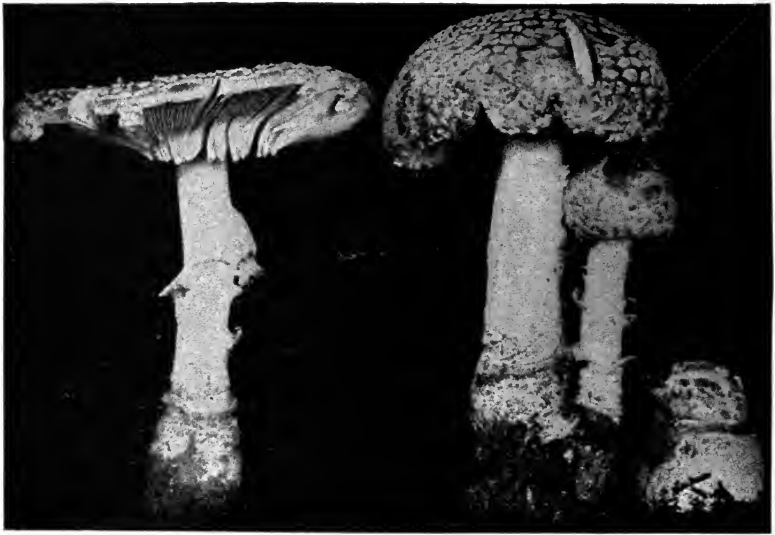

FIG. 145.—Deadly amanita (*Amanita muscaria*) showing volva at base of stem and frill, like stem ring. (After Chestnut, V. K., *Bull. 175, U. S. Dept. Agric., pl. i, Apr. 29, 1915.*)

**The Amanitas (Poisonous Fungi).**—*Amanita muscaria* and *Amanita phalloides*, commonly known as the “fly agaric” and the “deadly agaric” respectively, are very poisonous forms. *Amanita muscaria* is common in coniferous forests, although may occasionally be found in grassy places. It occurs singly and not in groups. *Amanita phalloides* is found in woods and borders of fields and, like the fly agaric, occurs singly and not in groups.

Each of these have fruiting bodies (sporophores), which begin at

the surface of the ground as a button similar to that of the edible mushroom. This enlarges and assumes a dumbbell shape. The whole button is covered by an outer veil, known as the *velum universale*, which encloses the pileus, gills and stipe. As the stipe lengthens more rapidly than the pileus, the upper part of the veil is stretched and finally breaks in its middle portion. The lower part remains as



FIG. 146.—The deadly amanita, *Amanita phalloides*. Note the cup at the base of the stipe. (Gager, from photo by E. M. Kittredge.)

a cup, out of which the stipe grows. The upper part is carried up as shreds adhering to the margin of the pileus. The lower part is called the *volva* or death cup. The annulus present is a false annulus, for it represents a peeling down of the upper part of the stipe. Both have chalk-white gills, a white stipe, and white spores.

The pileus of *Amanita muscaria* is yellow, or orange-red; the surface is smooth, with prominent warty scales.

The pileus of *Amanita phalloides* varies from dull yellow to olive to pure white. It does not possess the warty scales found in the *Amanita muscaria*, but occasionally has a few membranous patches.

#### Division b.—Gasteromycetes

(Hymenium inclosed)

**Order 1.—Lycoperdales, or puff ball alliance.** This order includes a number of interesting parasites and saprophytes the most common of which are the earth stars belonging to the genus *Geaster* and the

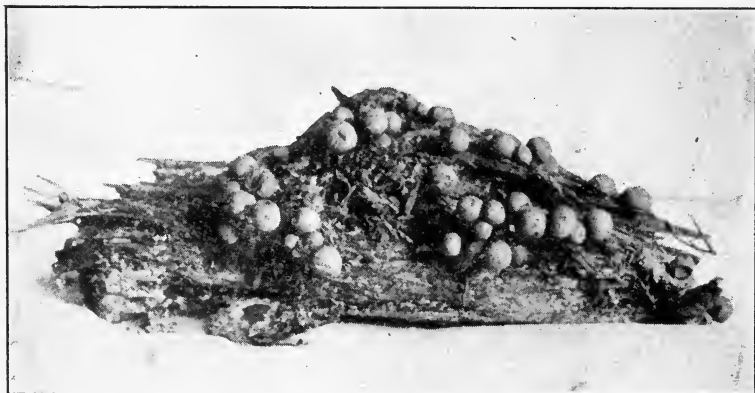

FIG. 147.—A colony of Puff Balls, *Lycoperdon*, growing saprophytically upon a portion of a rotten log. (Photograph by author.)

puff balls, the most common form being *Lycoperdon*. In these, the fruiting sporophore consists for the most part of a shell-like covering called the *peridium*, composed of an outer layer or *exoperidium* and an inner layer or *endoperidium*. The peridium in the unripe condition of the sporophore covers a mass of soft cellular tissue called the *gleba*. Upon the ripening of this mass, the interior is seen to be divided into many-branched compartments that are separated from each other by walls made up of branched hyphæ. These walls are lined with a hymenium composed of many basidia, each of which

constricts off usually four basidiospores. The earth stars differ from the puff balls in possessing an outer wall or exoperidium which splits in star-shaped fashion.

**Order 2.—Nidulariales**, the nest fungi. A group of Gasteromycetes whose sporophores are crucible- or crater-like. These arise from a subterranean mycelium and show an outer and inner peridial layer. The outer peridium is roughened at its base. The inner peridium is leathery and may or may not be continued over the top. When mature the crucible-like body shows black seed-like bodies inside which resemble eggs in a bird's nest. Each one of these is connected with the inner peridium by a cord which resembles the umbilical cord of an animal. These inner bodies are called *peridiola* (sing. *peridiolum*). Each peridiolum consists of a hard glistening outer layer and a spongy inner layer surrounding a cavity into which basidia and basidiospores project. These fungi are found in stiff clayey soil.

**Order 3.—Phallales**, the carrion or stink-horn fungi. This, the highest group of the Autobasidiomycetes, consists of highly and characteristically colored forms which, when mature, emit most vile and penetrating odors. The fruiting body, in each instance, begins as an egg-shaped structure which starts its growth from a widely spread underground mycelium of chalky-white color. As the "eggs" enlarge they push above the surface of the ground. The central portion, elongating, then breaks through the outer or peridial portion, which remains as a cup or volva at the base of the mature fruit body. Upon the summit of the central stalk rests the

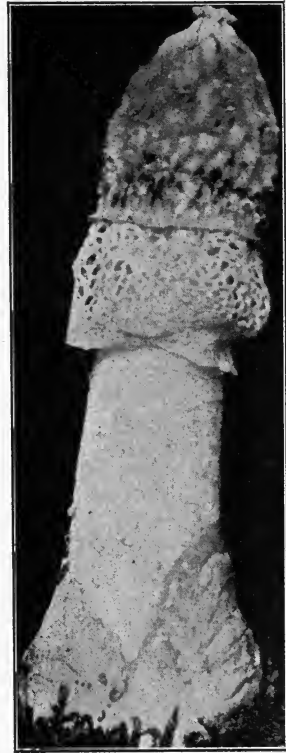

FIG. 148.—Mature stink-horn, *Dictyophora duplicata*. (Harshberger, from photo. by W. H. Walmsley.)

cup-like many-chambered gleba. The basidiospores are imbedded in a greenish fetid slime formed by a mucilaginous disintegration of the substance of the hymenium. This fetid green material is attractive to carrion flies which visit the plants and remove the material with its embedded spores. The latter will not germinate until after passing through the alimentary canal of these flies.

#### CLASS IV.—FUNGI IMPERFECTI

An assemblage of varied forms, the life histories of most of which are imperfectly understood. In this group are included numerous parasites which produce diseases in crop plants.

#### SUBDIVISION V.—LICHENS, THE LICHENS

Lichens are variously colored, usually dry and leathery plants, consisting of symbioses of algæ and fungi. In each case the fungus

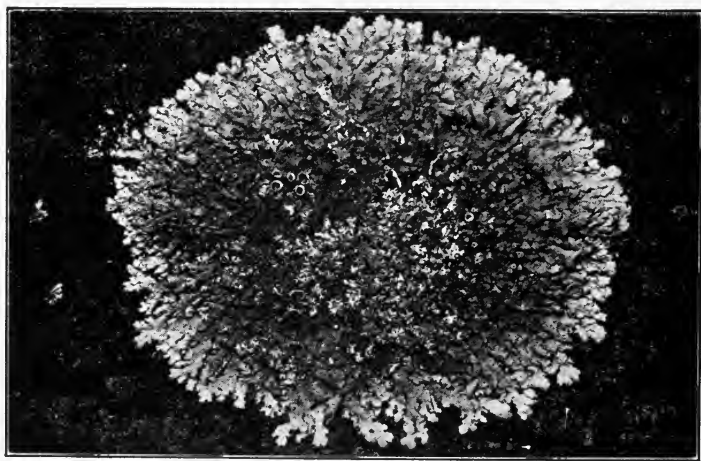

FIG. 149.—A foliaceous lichen, *Physica stellaris* (L.) Nyb., growing on a rock. The cup-shaped structures are the fruiting bodies (apothecia). At the left are seen two very young plants. (Gager.)

derives its food from materials manufactured by the algæ and in return extracts water from the substratum and shares it with the algæ. The association is therefore mutually beneficial. Blue-green and Protococcus forms of Green Algæ and Ascomycete Fungi are for the most part concerned in lichen formation.

Lichens are found on the bark of trees, on rocks, logs, old fences, etc. The body of a lichen shows a differentiation into two regions: a more or less compact row of cells on both surfaces, called the epidermis; and an inner portion composed of the mycelium of the fungus. The alga is imbedded in this portion. In most cases the spores are borne in asci, which are themselves found in closed or open *Apothecia*.

Scales or *soredia* are found on many lichens. These consist of a network of hyphæ enclosing algal cells. By becoming detached from the parent plant, they develop new lichens and so constitute a means of vegetative propagation.



FIG. 150.—*Cetraria islandica*. (Sayre.)

According to the manner of growth of the thallus and nature of attachment to the substratum, three different sub-groups of lichens may be distinguished, viz.: (1) Foliaceous where the thallus is flat, leathery and leaf-like and attached to the substratum at different points. To this group belong *Physcia* and *Parmelia*. (2) Crustaceous, where the thallus closely adheres to rocks and bark of trees. To this group belong *Graphis* and *Pertusaria*. (3) Fruticose, where the thallus is upright and branching. To the last group belong *Cetraria islandica*, species of *Cladonia*, and *Usnea*.

To the pharmacist and chemist lichens are chiefly of interest because of the coloring principles which they contain. Species of *Lecanora* and *Rocella tinctoria* yield, when subjected to fermentation,

the dyes orcein and litmus. Litmus is one of the best indicators in volumetric analysis. Cudbear, a purplish-red powder, used extensively for coloring pharmaceutical preparations in the form of tincture, is prepared by treating species of *Rocella*, *Lecanora* or other lichens with ammonia water. Other lichens, such as *Cetraria islandica*, various species of *Parmelia*, *Usnea* and *Alectoria*, have been used in medicine because of demulcent principles which they contain.

## DIVISION II.—BRYOPHYTA

Plants showing a beginning of definite alternation of generations, *i.e.*, gametophyte (sexual phase) alternating with sporophyte

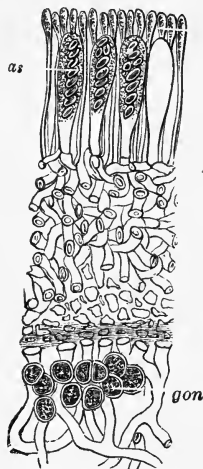

FIG. 151.

FIG. 151.—Section of thallus of *Cetraria islandica* through an apothecium. *as*, Asci, three of which contain ascospores. *gon*, Gonidia. The inner (central portion shows the mycelial threads of a fungus entangling the alga. (Sayre.)

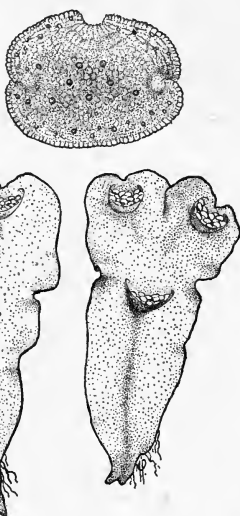

FIG. 152.

FIG. 152.—A liverwort (*Lunularia*). Below, portions of the thallus, showing the lunar-shaped cupules, with brood-buds, or gemmæ. Above a single gemma, greatly magnified. (Gager.)

(asexual phase of development) in their life history, the two phases being combined in one plant. The female sexual cell is always lodged in an *archegonium* (a multicellular female sexual organ).



## SUBDIVISION I.—HEPATICÆ OR LIVERWORTS

Plants of aquatic or terrestrial habit whose bodies consist of a rather flat, furchate branching thallus or leafy branch which is dorsoventral (having distinct upper and lower surface); the upper surface consists of several layers of cells containing chlorophyll, which gives the green color to the plants; the lower surface gives origin to hair-like outgrowths of the epidermal cells serving as absorptive parts and called *rhizoids*. Upon the dorsal surface of this thaloid body (the gametophyte) cup-like structures are produced called *cupules* which contain special reproductive bodies called *gemmae*, these being able to develop into new gametophytes. The sex organs are of two kinds, male and female. The male organs are termed antheridia, the female, archegonia. The antheridia are more or less club-shaped, somewhat stalked organs consisting of an outer layer of sterile cells investing a mass of sperm mother-cells from which are formed the spirally curved biciliate antherozoids, or male sexual cells. The archegonia are flask-shaped organs consisting of an investing layer of sterile cells surrounding an axile row of cells, the neck-canal cells, ventral-canal cells and the egg or female sexual cells. Every cell of the axial row breaks down in the process of maturation with the exception of the egg which remains in the basal portion. Both antheridia and archegonia generally arise on special stalks above the dorsal surface. After the egg is fertilized by a antherozoid, the young embryo resulting grows into a *sporogonium* (the sporophyte) consisting of a stalk portion partly imbedded in the archegonium surmounting a sporangium or capsule in which spores are produced. When mature the capsule splits open discharging the spores. The spores on germination develop into a *protonema* or filamentous outgrowth which later develops the thallus.

**Order 1.**—**Marchantiales**, including *Marchantia* and *Riccia*.

**Order 2.**—**Jungermanniales**, the leafy liverworts, including *Porella*.

**Order 3.**—**Anthocerotales**, having the most complex sporophyte generations among liverworts, including *Anthoceros*, and *Megaceros*.

## SUBDIVISION II.—MUSCI OR MOSSES

Plants found on the ground, on rocks, trees and in running water. Their life histories consist of two generations, gametophyte and

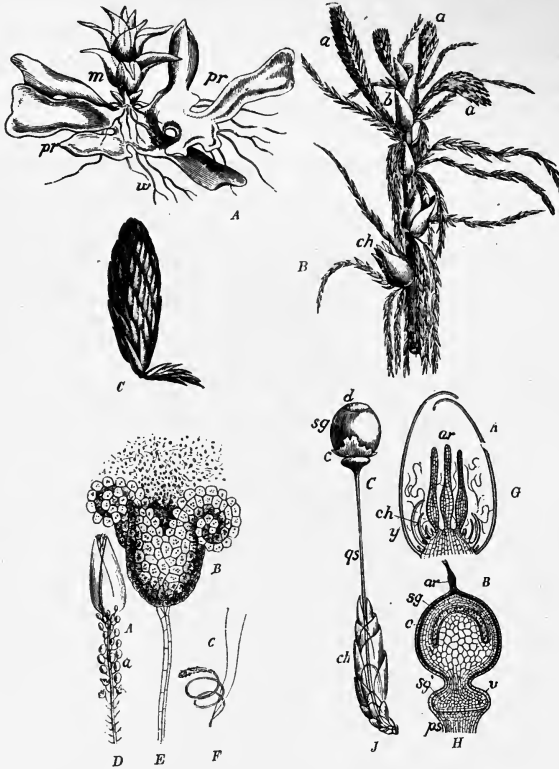

FIG. 153.—*Sphagnum acutifolium*, Ehrb. A, prothallus (*pr*), with a young leafy branch just developing from it; B, portion of a leafy plant; *a*, male cones; *ch*, female branches; C, male branch or cone, enlarged with a portion of the vegetative branch adhering to its base; D, the same, with a portion of the leaves removed so as to disclose the antheridia; E, antheridium discharging spores; F, a single sperm; G, longitudinal section of a female branch, showing the archegonia (*ar*); H, longitudinal section through a sporogonium; *sg*<sup>1</sup>, the foot; *ps*, pseudopodium; *c*, calyptra; *sg*, sporogonium, with dome of sporogenous tissue; *ar*, old neck of the archegonium; J, *Sphagnum squarrosum* Pers.; *d*, operculum; *c*, remains of calyptra; *qs*, mature pseudopodium; *ch*, perichætium. (Gager, from Schimper.)

sporophyte similar to the liverworts but differ from liverworts, generally, by the ever-present differentiation of the gametophyte

body into distinct stem and simple leaves, and the formation of the sexual organs at the end of an axis of a shoot. They are either *monœcious*, when both kinds of sexual organs are borne on the same plant,

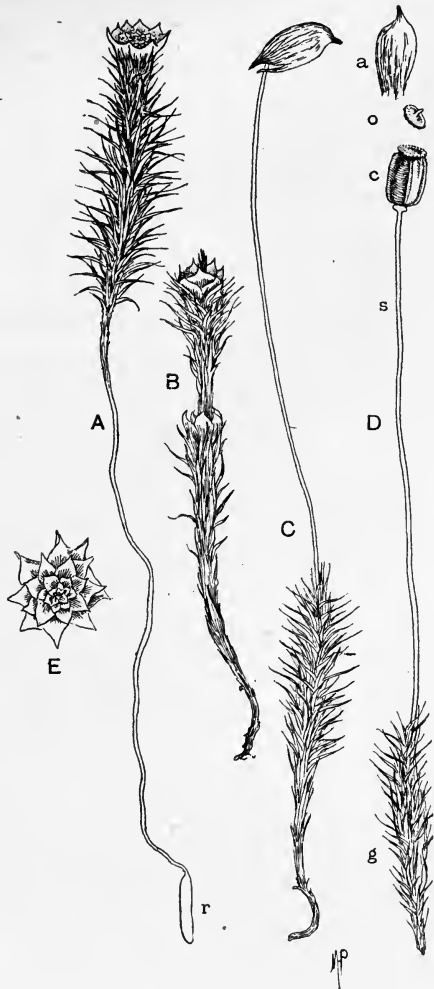

FIG. 154.—Hair-cap moss (*Polytrichum commune*). A, male plant; B, same, proliferating; C, female plant, bearing sporogonium; D, same; g, gametophyte; s, seta; c, capsule; o, operculum; a, calyptra; E, top view of male plant. (Gager.).

or *diœcious*, in which case the antheridia and archegonia arise on different plants.

**Order 1.**—**Sphagnales**, or Bog Mosses, including the simple genus, *Sphagnum*. Pale mosses of swampy habit whose upper extremities repeat their growth periodically while their lower portions die away gradually and form peat, hence their frequent name of Peat Mosses.

A number of species of *Sphagnum* have been recently employed in surgery as absorbents in place of gauze. For this purpose they must be thoroughly cleaned and sterilized.

**Order 2.**—**Andreæales**, including the single genus *Andreæa*, of xerophytic habit, occurring on siliceous rock.

**Order 3.**—**Bryales**, or true mosses, comprising<sup>1</sup> the most highly evolved type of bryophytes. Examples: *Polytrichum*, *Funaria*, *Hypnum*, and *Mnium*.

#### **Life History of Polytrichum Commune (A Typical True Moss).—**

*Polytrichum commune* is quite common in woods, forming a carpet-like covering on the ground beneath tall tree canopies. It is diœcious, the plants being of two kinds, male and female.

Beginning with a spore which has fallen to the damp soil, we note its beginning of growth (germination) as a green filamentous body called a *protonema*. This protonema soon becomes branched, giving rise to hair-like outgrowths from its lower portion called *rhizoids* and *lateral buds* above these which grow into leafy stems commonly known as "moss plants." At the tips of some of these leafy stems *antheridia* (male sexual organs) are formed while on others *archegonia* (female sexual organs) are formed. These organs are surrounded at the tips by delicate hairy processes called *paraphyses* as well as leaves for protection. The antheridia bear the antherozoids, the archegonia, the eggs or ova, as in the liverworts. When an abundance of moisture is present, the antherozoids are liberated from the antheridia, swim through the water to an archegonium and descend the neck canal, one fertilizing the egg by uniting with it. This completes the sexual or gametophyte generation. The fertilized egg now undergoes division until an elongated stalk bearing upon its summit a capsule is finally produced, this being known as the *sporogonium*. The base of the stalk remains imbedded in the basal portion of the archegonium, at the tip of the leafy

stalk, and forms a *foot* or absorbing process. In growing upward the sporogonium ruptures the neck of the archegonium and carries it upward as the covering of the capsule, or *calyptra*. The calyptra is thrown off before the spores are matured within the capsule. The upper part of the capsule becomes converted into a lid or *operculum* at the margin of which an *annulus* or ring of cells forms. The cells of the annulus are hygroscopic and expand at maturity, throwing off the lid and allowing the *spores* to escape. This completes



FIG. 155.—Protonemata of a moss bearing young gametophyte bud. (Gager.)

the asexual or sporophyte generation. The spores falling to the damp soil germinate into protonemata, thus completing the life cycle in which is seen an alteration of generations, the two phases, gametophyte alternating with sporophyte.

### DIVISION III.—PTERIDOPHYTA

The most highly developed cryptogams showing a distinct alteration of generations in their life history. They differ from the Bryophytes in presenting independent, leafy, vascular, root-bearing sporophytes.

## SUBDIVISION I.—LYCOPODINEÆ OR CLUB MOSSES

Small perennial, vascular, dichotomously branched herbs with stems thickly covered with awl-shaped leaves. The earliest forms of vascular plants differing from ferns in being comparatively simple in structure, of small size, leaves sessile and usually possessing a single vein. Except in a few instances the sporangia are borne on leaves, crowded together and forming cones or spikes at the ends of the branches—Homosporous.



FIG. 156.—*Lycopodium clavatum*. (Gager.)

**Family I.—Lycopodiaceæ**, including the single genus *Lycopodium* with widely distributed species. The spores of *Lycopodium clavatum* are official.

**Family II.—Selaginellaceæ**, including the single genus *Selaginella* with species for the greater part tropical. Plants similar in habit to the Lycopodiaceæ but showing heterospory.

**Family III.—Isoetaceæ**, including the single genus *Isoetes* whose species are plants with short and tuberous stems giving rise to a tuft

of branching roots below and a thick rosette of long, stiff awl-shaped leaves above—Heterosporous.

SUBDIVISION II.—EQUISETINEÆ

(The Horsetails or Scouring Rushes)

The Equisetineæ, commonly known as the Horsetails or Scouring rushes, are perennial plants with hollow, cylindrical, jointed and

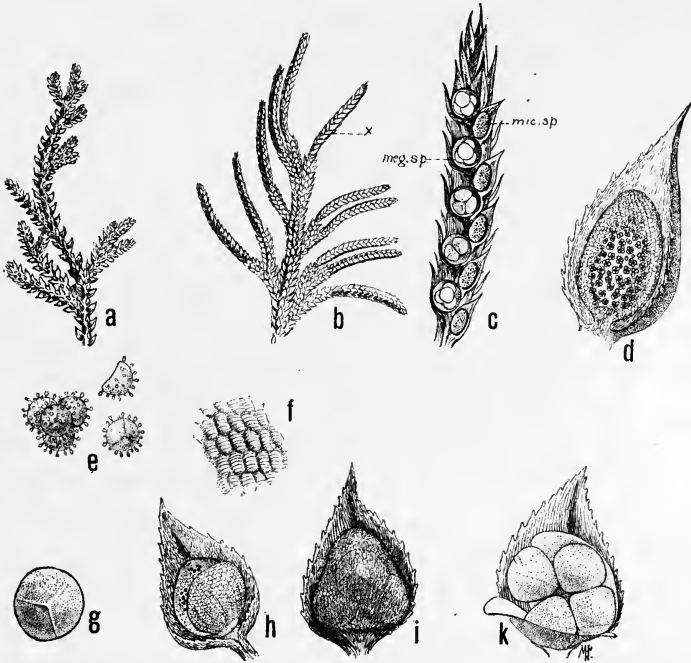

FIG. 157.—*Selaginella Martensii*. *a*, vegetative branch; *b*, portion of the stem, bearing cones (*x*); *c*, longitudinal section of a cone, showing microsporangia (*mic. sp.*) in the axils of microsporophylls, and megasporangia in the axils of megasporophylls; *d*, microsporangium with microsporophyll; *e*, microspores; *f*, portion of wall of sporangium, greatly magnified; *g*, megaspore; *h*, microsporangium opened, and most of the microspores scattered; *i*, megasporangium, with mega-sporophyll; *k*, same, opened, showing the four megaspores. (*Gager.*)

fluted stems, sheath-like whorls of united leaves and terminal cone-like fructifications. Their bodies contain large amounts of silicon, hence the name scouring rushes.

In some varieties the fruiting cone is borne on the ordinary stem, in others on a special stem of slightly different form. In the latter the spores are provided with elaters, which, being hygroscopic, coil and uncoil with increase or decrease in the amount of moisture present, thus aiding in the ejection of spores from the sporangia. The number of species is small and included under one genus, *Equisetum*. (See fig. 158.)

### SUBDIVISION III.—FILICINEÆ

The group Filicineæ is the largest among the vascular cryptogams and includes all the plants commonly known as Ferns. The main axis of a typical fern is a creeping underground stem or *rhizome* which at its various nodes bears *rootlets* below and *fronds* above. These fronds are highly developed, each being provided with a petiole-like portion called a *stipe* which is extended into a *lamina* usually showing a forked venation. Some ferns possess laminae which are lobed, each lobe being called a *pinna*. If a pinna be further divided, its divisions are called *pinnules*. The unfolding of a frond is circinate and it increases in length by apical growth. On the under surface of the laminae, pinnae, or pinnules may be seen small brown patches each of which is called a *sorus*, and usually covered by a membrane called the *indusium*. Each sorus consists of a number of *sporangia* (spore cases) developed from epidermal cells. In some ferns the entire leaf becomes a spore-bearing organ (sporophyll). Most sporangia have a row of cells around the margin, the whole being called the *annulus*. Each cell of the annulus has a U-shaped thickened cell wall. Water is present within these cells and when it evaporates it pulls the cell walls together, straightening the ring and tearing open the weak side. The annulus then recoils and hurls the spores out of the sporangium. Upon coming into contact with damp earth each spore germinates, producing a green septate filament called a *protonema*. This later becomes a green heart-shaped body called a *prothallus*. It develops on its under surface *antheridia* or male organs and *archegonia* or female organs as well as numerous *rhizoids*. Within the antheridia are developed motile *sperms*, while *ova* are produced within the archegonia. The many ciliate sperms escape from the antheridia of one prothallus during a



wet season, and, moving through the water, are drawn by a chemotactic influence to the archegonia of another prothallus, pass down the neck canals of these and fuse with the ova, fertilizing them. The fertilized egg or oöspore divides and redivides and soon becomes differentiated into stem-bud, first leaf, root, and *foot*. The foot

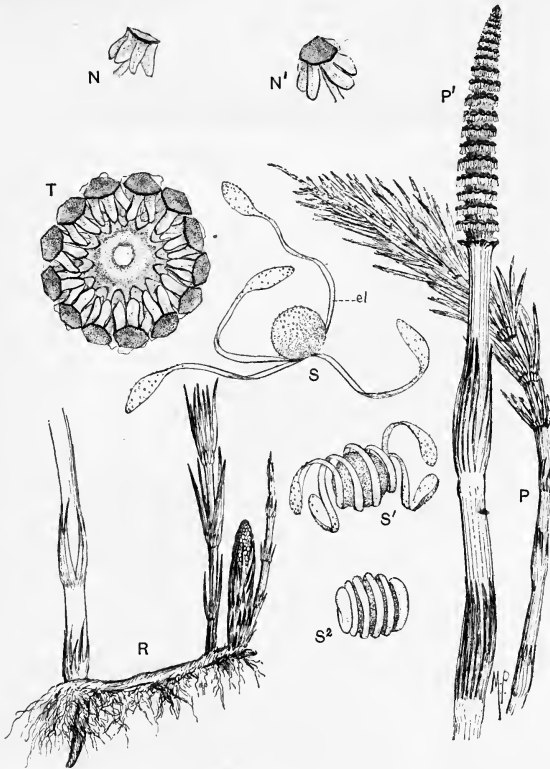

FIG. 158.—*Equisetum arvense*. P, sterile branch; P<sup>1</sup>, fertile branch with strobilus, or cone; R, rhizome (underground); T, cross-section of cone, showing insertion of sporophylls in a whorl; N, N<sup>1</sup>, sporophylls with pendant sporangia; S, S<sup>1</sup>, S<sup>2</sup>, spores with coiled elaters (el). (Gager.)

obtains nourishment from the prothallus until the root grows into the soil, when it atrophies, and the sporophyte becomes independent. Unequal growth and division of labor continue until a highly differentiated sporophyte results, the mature "fern plant."

### ORDER 1.—FILICALES OR TRUE FERNS (HOMOSPOROUS)

*Family Polypodiaceæ.*—Sporangia with annulus vertical and incomplete.

The rhizomes and stipes of *Dryopteris filix-mas* and *Dryopteris marginalis* are official in the U. S. P. The fibro-vascular bundles of these are concentric in type but differ from the concentric fibro-vascular bundles of some monocotyledons in that xylem is innermost and phloem surrounds the xylem.

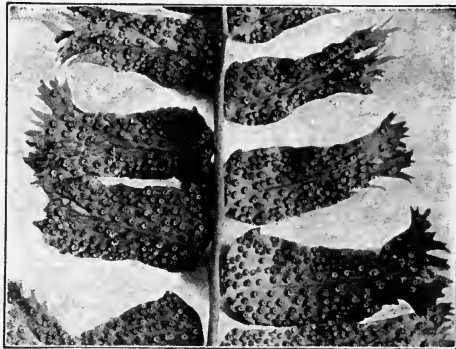

FIG. 159.—*Cyrtomium falcatum*. Under (dorsal) surface of a portion of a sporophyll, showing the numerous sori on the pinnae. (Gager.)

### ORDER 2.—HYDROPTERALES OR WATER FERNS (HETEROSPOROUS)

*Family Salviniaceæ.* Floating ferns with broad floating leaves and submerged dissected leaves which bear sporocarps. Examples: *Salvinia* and *Azolla*.

### DIVISION IV.—SPERMATOPHYTA (PHANEROGAMIA)

Plants producing real flowers and seeds. The highest evolved division of the vegetable kingdom.

#### SUBDIVISION I.—GYMNOSPERMÆ—THE GYMNOSPERMS

The Gymnosperms comprise an ancient and historic group of seed plants which were more numerous in the Triassic and Carboniferous

periods than now. They differ from the Angiosperms in several respects, viz.: they bear naked ovules on the edges or flat surfaces of leaves called carpels, while Angiosperms bear covered ones; each megaspore produces within itself a bulky prothallus, in the upper portion of which originate one or more archegonia, while in Angiosperms no recognizable prothallus has been proven to exist; the stored food tissue within their seeds is prothallial tissue loaded with starch, etc., while that in Angiosperm seeds (endosperm) is developed from the endosperm nucleus; the mode of growth of their stems is always indefinite while that of Angiosperms is either indefinite or definite.

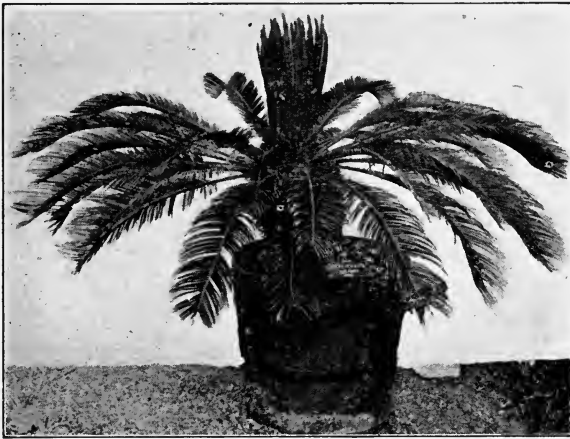

FIG. 160.—*Cycas revoluta*, showing terminal bud of foliage-leaves just opening. (Gager.)

The groups still extant are the Cycads or Fern Palms, the Gnetums, the Ephedras, the Ginkgos and the Conifers. Of these the Conifers comprising over 300 species are the most numerous. Many of them yield valuable products to pharmacy and the arts.

The Conifers include the pines, spruces, hemlocks, cedars, firs, arbor vitæ, chamæcyparis, and larches. All of their number are evergreen except the larches, which drop their foliage upon the advent of winter.

**I. Order Coniferales.**—Trees with a single upright stem which develops side branches that spread out horizontally and taper to a point at the summit, giving the crown of the tree the appearance of a huge cone, rarely shrubs.

*Pinaceæ (Coniferæ) or Pine Family.*—Trees or shrubs with resinous juice whose wood is characterized by being composed largely of tracheids with bordered pits. Leaves entire, awl- or needle-shaped frequently fascicled, exstipulate, usually evergreen. Flowers, monoëcious or rarely diëcious, achlamydeous, in cones. Staminate



FIG. 161.—Inflorescences of the pine. 1, Terminal twig; 2, ovulate cone; 3, staminate cone; 4, two-year-old cone. (Hamaker.)

cone of a large number of microsporophylls (stamens) closely packed together and arranged spirally around a central axis, each stamen bearing usually two pollen sacs. Carpellate cone composed of spirally arranged scales, each of which bears a pair of naked ovules (megaspores) near the base of its upper face, or, ovules springing from a cupuliform disc. Fruit a cone with woody or fleshy scales (*Pinus*, *Thuja*, *Abies*, *Picea*, etc.), a galbanus (*Juniperus*) or a drupe composed of the thickened and fleshy disc surrounding an erect seed (*Taxus*). Seeds albuminous. Embryo with two or more cotyledons.

| Official drug                                 | Part used                                | Botanical origin  | Habitat   |
|---|--|---|---|
| Terebinthina N.F.                             | Concrete oleoresin                       | <i>Pinus palustris</i><br>and other species<br>of <i>Pinus</i>        | Southern United<br>States   |
| Resina  | Resin                                    | <i>Pinus palustris</i><br>and other species<br>of <i>Pinus</i>        | Southern United<br>States   |
| Oleum Tere-<br>binthinæ                       | Volatile oil                             | <i>Pinus palustris</i><br>and other species<br>of <i>Pinus</i>        | Southern United<br>States   |
| Pix Liquida . .                               | Product of destruc-<br>tive distillation | <i>Pinus palustris</i><br>and other species<br>of <i>Pinus</i>        | Southern United<br>States   |
| <i>Pinus Alba</i> N.F.                        | Inner bark                               | <i>Pinus Strobus</i>  | United States and<br>Canada                                       |
| Oleum Pini Pumi-<br>lionis                    | Volatile oil                             | <i>Pinus montana</i>  | Tyrolese Alps   |
| Terebinthina<br><i>Laricis</i> N.F.           | Oleoresin                                | <i>Larix europæa</i>  | Alps and<br>Carpathians   |
| <i>Juniperus</i> N.F.                         | Fruit                                    | <i>Juniperus</i><br><i>communis</i>                                   | } North America,<br>Europe and Asia                               |
| Oleum Juniperi                                | Volatile oil                             | <i>Juniperus</i><br><i>communis</i>                                   |   |
| Oleum Cadinum<br><i>Thuja</i> N.F.            | Empyreumatic oil<br>Leafy young twigs    | <i>Juniperus Oxycedrus</i><br><i>Thuja occidentalis</i>               | So. Europe<br>United States and<br>Canada                         |
| Oil of Cedarwood                              | Oil from wood                            | <i>Juniperus</i><br>Virginiana  | North America   |
| <b>Unofficial drug</b>                        |  |   |   |
| Sabina  | Tops                                     | <i>Juniperus Sabina</i>   | Europe  |
| Pix Burgundica                                | Resinous exudate                         | <i>Abies excelsa</i>  | Europe and Asia   |
| Terebinthina<br><i>Canadensis</i>             | Liquid oleoresin                         | <i>Abies balsamea</i>   | Northern United<br>States and Canada                              |
| Sandaraca                                     | Resinous exudate                         | <i>Callitris</i><br><i>quadrivalvis</i>                               | Africa  |
| Dammar  | Resinous exudate                         | <i>Agathis</i><br><i>loranthifolia</i>                                | E. India  |
| Succinum (Amber)<br>Bordeaux                  | Fossil resin<br>Concrete oleoresin       | <i>Pinites succinifer</i><br><i>Pinus maritima</i>                    | Basin of Baltic<br>France   |
| Turpentine                                    |  |   |   |
| Pix <i>Canadensis</i><br><i>Oregon</i> Balsam | Oleoresin<br>Oleoresin                   | <i>Tsuga canadensis</i><br><i>Pseudotsuga</i><br><i>mucronata</i>     | North America<br>Western United<br>States and<br>British Columbia |
| Spruce Gum                                    | Gum                                      | <i>Picea canadensis</i><br><i>Picea mariana</i><br><i>Picea rubra</i> | } Canada and New<br>England                                       |

## SUBDIVISION II.—ANGIOSPERMÆ OR ANGIOSPERMS

(Plants with covered seeds).

## CLASS A.—MONOCOTYLEDONEÆ

A class of Angiosperms characterized by the following peculiarities:

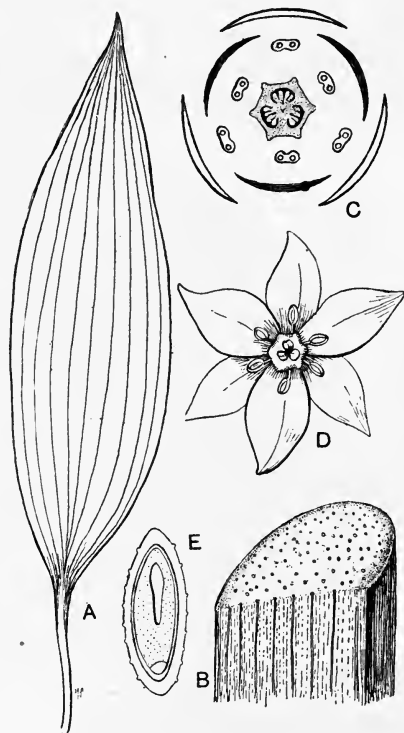

FIG. 162.—Morphology of the typical monocotyledonous plant. *A*, leaf, parallel-veined; *B*, portion of stem, showing irregular distribution of vascular bundles; *C*, ground plan of flower (the parts in 3's); *D*, top view of flower; *E*, seed, showing monocotyledonous embryo. (*Gager.*)

One cotyledon or seed leaf in the embryo.

Stems endogenous with closed collateral or concentric fibro-vascular bundles, which are scattered.

Leaves generally parallel veined.

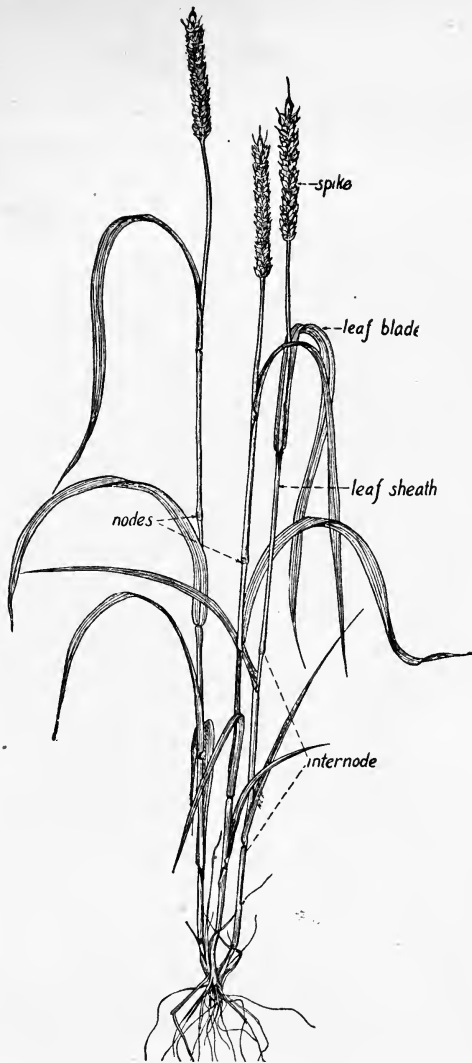

FIG. 163.—Wheat plant showing the general habit of grasses. (*Robbins.*)

Flowers trimerous (having the parts of each whorl in threes or multiple thereof).

Secondary growth in roots generally absent.

Medullary rays generally absent.

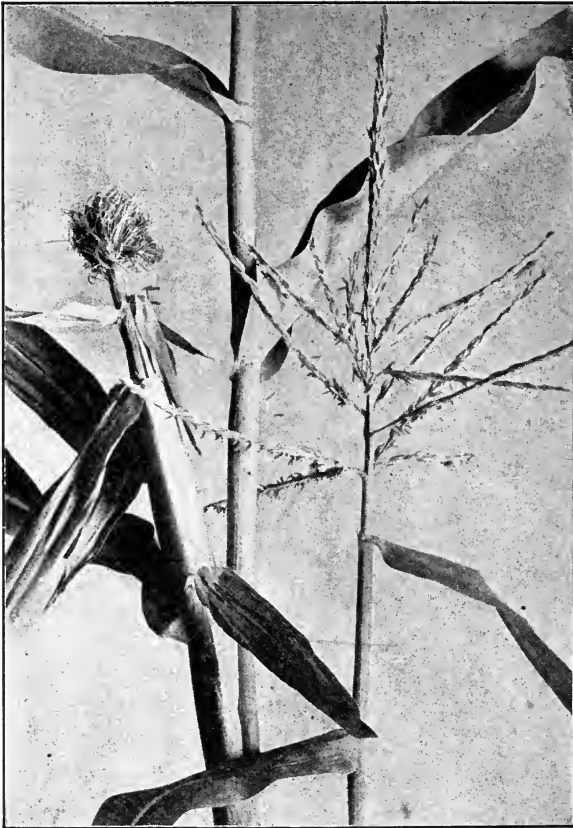

FIG. 164.—Pistillate and staminate inflorescences of corn (*Zea mays*).  
(Robbins.)

**I. Order Graminales.**—*Gramineæ* or *Grass Family*.—Mostly herbs with cylindric, hollow jointed stems whose nodes are swollen. The leaves are alternate, with long split sheaths and a ligule. Flow-



ers generally hermaphroditic and borne in spikelets, making up a spicate inflorescence. Lowest floral leaves of each spikelet are called glumes, which are empty and paired. Fruit, a caryopsis or grain. Embryo with scutellum. Seeds, albuminous. Seed coat fused with fruit coat to form one layer.

| Official drug | Part used                            | Botanical name          | Habitat         |
|---------------|--------------------------------------|-------------------------|-----------------|
| Triticum      | Rhizome and roots                    | Agropyron repens        | Europe and Asia |
| Saccharum     | Refined sugar                        | Saccharum officinarum   | Tropics         |
|               |                                      | Beta vulgaris var. Rapa | Germany         |
|               |                                      | and Sorghum sp.         | Asia and Africa |
| Maltum        | Seed, partially germinated and dried | Hordeum sativum         | Asia            |
| Amylum        | Starch                               | Zea Mays                | Mexico          |
| Zea N.F.      | Styles and stigmas                   | Zea Mays                | Mexico          |

**II. Order Principles.**—*Palmeæ* or *Palm Family*.—Tropical or subtropical shrubs, rarely trees, having unbranched trunks which are terminated by a crown of leaves, in the axils of which the flowers are produced. The leaves are well developed with pinnate or palmate blades and a fibrous sheathed clasping petiole. The flowers are small, of one or two sexes, and crowded on a spike or spadix, which is subtended by a large bract, or spathe which may become woody, as in the Cocoanut Palm. The perianth consists of 6 parts in 2 whorls (3 sepals and 3 petals) or it may be inconspicuous or absent. The stamens are 6 in number, rarely 3, inserted below the ovary. The ovary is superior, of 3 cells, with central placenta. The fruit is either a nut, with leathery epicarp, fibrous or cellular mesocarp and thin membranous endocarp, or a drupe (Cocoanut) with leathery epicarp, broadly fibrous mesocarp and stony endocarp, or a berry as in the Date Palm, *Phoenix*, with membranous epicarp, succulent mesocarp and soft succulent endocarp. The seeds are albuminous with the reserve food frequently in the form of hard cellulose (ivory-nut-palm).

| Official drug     | Part used         | Botanical name             | Habitat                   |
|-------------------|-------------------|----------------------------|---------------------------|
| Sabal             | Fruit (drupe)     | <i>Serenoa serrulata</i>   | South Carolina to Florida |
| <b>Unofficial</b> |                   |                            |                           |
| Dragon's Blood    | Inspissated juice | <i>Calamus Draco</i>       | East Indies               |
| Cocanut oil       | Fixed oil         | <i>Cocos nucifera</i>      | Tropics                   |
| Carnauba wax      | Wax from leaves   | <i>Copernicia cerifera</i> | Brazil                    |
| Areca nut         | Seed              | <i>Areca Catechu</i>       | Asia and East Indies      |
| Palm oil          | Fixed oil         | <i>Elæis guineensis</i>    | West Africa               |



FIG. 165.—Sabal palmetto. This palm, which appears in the center of the figure, yields the official drug, sabal. In the right distance a barragona palm. Cuba. (Gager.)

III. Order Arales.—*Araceæ* or *Arum* Family.—Perennial herbs with fleshy rhizomes or corms, and long petioled leaves, containing an acrid or pungent juice. Flowers crowded on a spadix, which is usually surrounded by a spathe. Fruit a berry. Seeds with large fleshy embryo.

| Unofficial drug | Part used        | Botanical name                  | Habitat                        |
|-----------------|------------------|---------------------------------|--------------------------------|
| Calamus         | Unpeeled rhizome | <i>Acorus calamus</i>           | Europe, Asia,<br>North America |
| Skunk cabbage   | Rhizome          | <i>Symplocarpus<br/>fœtidus</i> | North America                  |
| Indian turnip   | Corm!            | <i>Arisæma<br/>triphyllum</i>   | North America                  |

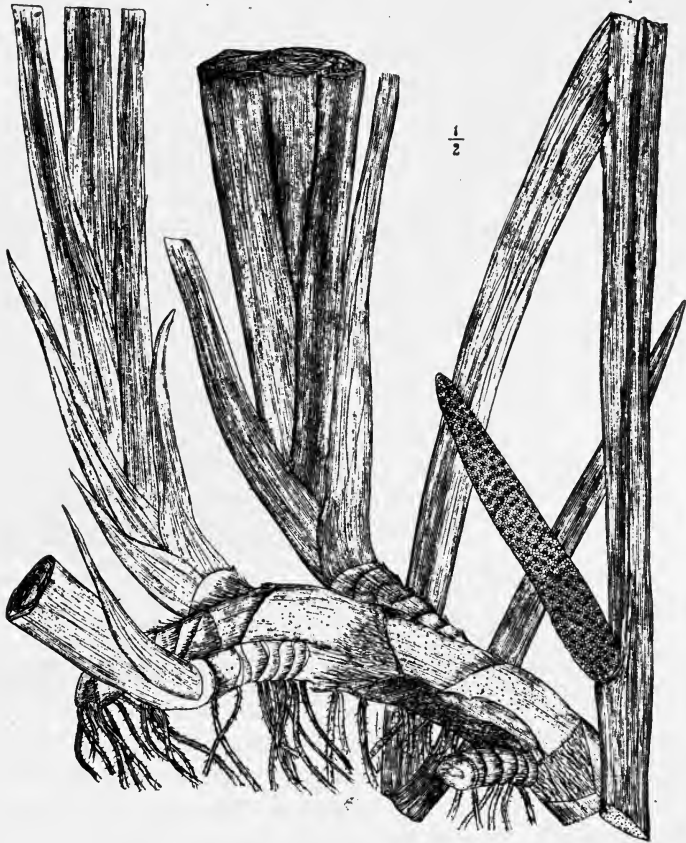

FIG. 166.—*Acorus calamus*. (Sayre.)

IV. Order Liliales.—*Liliaceæ* or *Lily Family*.—Herbs (*Lilium*), shrubs (*Yucca*), or trees (*Dracena Draco*), with regular and symmetrical almost always six-anded flowers. Stem either short,

creeping underground (*Polygonatum*), or, swelling up and forming bulbs (Hyacinth), or corms (*Colchicum*), or, stem may elongate above ground and become wiry and herbaceous or semi-shrubby as *Smilax*, or the stem may remain short giving rise to thick fleshy and sap-storing leaves as in *Aloe*. Leaves linear to lanceolate, ovate rarely wider, divisible into sheathing base, narrow petiole and ex-

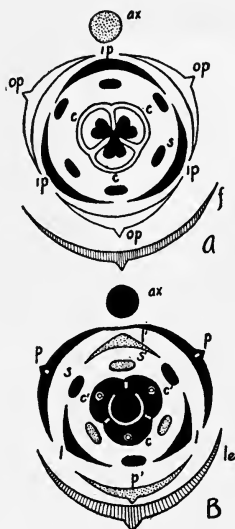

FIG. 167.—Diagram of A, lily flower, and B, grass flower, showing homologous structures. A, *f*, bract; *ax*, axis; *op*, outer perianth; *ip*, inner perianth; *s*, stamens; (*c*) tricarpeal ovary. B, shaded structures are aborted; *le*, lemma (bract); *ax*, axis; *p* and *p'*, palea (outer perianth); *l* and *l'*, lodicules (inner perianth); *s* and *s'*, two whorls of stamens; *c*, tricarpeal ovary. (A, Robbins. B, after Shuster.)

panded blade. Venation, parallel, becoming in some ovate leaves parallel with oblique connections, reticulate or highly reticulate as in *Smilax*, etc. The perianth is parted into six segments, the calyx and corolla being alike in color. Anthers introrse. Ovary three-locular with a single style. Fruit a three-locular, loculicidally dehiscent capsule (*Lilium*, etc.) or rarely a berry (*Asparagus*, etc.). Seeds usually numerous, albuminous.

| Official drug   | Part used         | Botanical name   | Habitat   |
|-----------------|-------------------|--|---|
| Sarsaparilla    | Root              | {<br><i>Smilax medica</i><br><i>Smilax ornata</i><br><i>Smilax officinalis</i> | Mexico<br>Costa Rica<br>Guatemala,<br>Honduras and<br>Nicaragua |
| Veratrum        | Rhizome and roots | <i>Veratrum viride</i>   | United States   |
| Colchici Cormus | Corm              | <i>Colchicum autumnale</i>   | Mediterranean Basin   |

| Official drug           | Part used                   | Botanical name   | Habitat  |
|-------------------------|-----------------------------|--|--|
| Colchici Semen          | Seed                        | <i>Colchicum autumnale</i>   | Mediterranean Basin  |
| Aloe                    | Inspissated juice of leaves | {<br><i>Aloe vera</i><br><i>Aloe Perryi</i><br><br><i>Aloe ferox</i> | Dutch West Indies<br>Socotra and East Africa<br>South Africa |
| Scilla                  | Bulb                        | <i>Urginea maritima</i>  | Mediterranean Basin  |
| Veratrina               | Mixture of alkaloids        | <i>Asagræa officinalis</i>   | Mexico and Central America                                   |
| Convallariæ Radix N.F.  | Rhizome and roots           | {<br><i>Convallaria majalis</i>                                      | {<br>Europe, Asia,<br>United States                          |
| Convallariæ Flores N.F. | Inflorescence               |  |  |
| Trillium N.F.           | Rhizome and roots           | <i>Trillium erectum</i>  | North America  |
| Allium N.F.             | Bulb (fresh)                | <i>Allium sativum</i>  | Europe, Asia<br>North America                                |
| Aletris N.F.            | Rhizome and roots           | <i>Aletris farinosa</i>  | Eastern United States  |
| Helonias N.F.           | Rhizome and roots           | <i>Chamælerium luteum</i>  | Eastern United States  |

*Dioscoreaceæ* or *Yam Family*.—Herbs or shrubs with twining stems arising from large tuberous roots or knotted rootstocks. Leaves ribbed and netted-veined. Flowers small, diœcious, regular, having a six-cleft calyx-like perianth, six stamens and a three-celled ovary. Fruit usually a membranous three-angled or winged capsule.

| Official drug  | Part used | Botanical name           | Habitat       |
|----------------|-----------|--------------------------|---------------|
| Dioscorea N.F. | Rhizome   | <i>Dioscorea villosa</i> | United States |

*Iridaceæ* or *Iris Family*.—Perennial herbs with equitant two-ranked leaves and regular or irregular flowers which are showy. Fruit a three-celled, loculicidal, many-seeded capsule. Rootstocks, tubers, or corms mostly acrid.

| Official drug           | Part used      | Botanical name  | Habitat                  |
|-------------------------|----------------|---|--------------------------|
| Iris N.F.               | Peeled rhizome | { Iris florentina<br>Iris pallida<br>Iris germanica } | Europe                   |
| Iris Versicolor<br>N.F. | Rhizome        | Iris versicolor                                       | Eastern United<br>States |
| Crocus N.F.             | Stigmas        | Crocus sativus  | Mediterranean<br>Basin   |

**V. Order Scitaminales.**—*Zingiberaceæ* or *Ginger Family*.—Tropical plants, perennial herbs, with fleshy rhizomes and large elliptical pinnately-veined leaves. The leaf sheaths are folded tightly around each other so as to give the appearance of a stem. Flowers, very irregular, trimerous; sepals three short, often green; petals three, elongate, often fused below; stamens three to four abortive, petaloid, one often absent, a sixth alone fertile and stamen-like. The petaloid stamens constitute the most attractive parts of the flower. Pistil, inferior, tricarpellary. Fruit, a capsule. Seeds, albuminous with both perispermic and endospermic albumen.

| Official drug                     | Part used        | Botanical name          | Habitat          |
|-----------------------------------|------------------|-------------------------|------------------|
| Zingiber                          | Rhizome          | Zingiber officinale     | Asia             |
| Cardamomi<br>Semen                | Seeds            | Elettaria<br>Cardamomum | Indo-China       |
| Galanga N.F.                      | Rhizome          | Alpinia<br>officinarum  | Asia             |
| Zedoaria N.F.                     | Rhizome          | Curcuma Zedoaria        | Asia, Madagascar |
| <b>Unofficial drug</b><br>Curcuma | Prepared rhizome | Curcuma longa           | South Asia       |

VI. Order Orchidales.—*Orchidaceæ* or *Orchid Family*.—Perennial herbs of terrestrial or terrestrial saprophytic or epiphytic growth,



FIG. 168.—*Smilax officinalis*—Portion of vine and rhizome. (Sayre.)

having grotesque flowers. Roots fibrous or tuberous often saprophytic in relation, or aerial and with velamen. Stems and branches

upright, in epiphytic types, often forming pseudobulbs. Leaves alternate, entire, parallel-veined, sheathing at base, rarely reduced to yellowish or pale scales in saprophytes. Flowers irregular, usu-

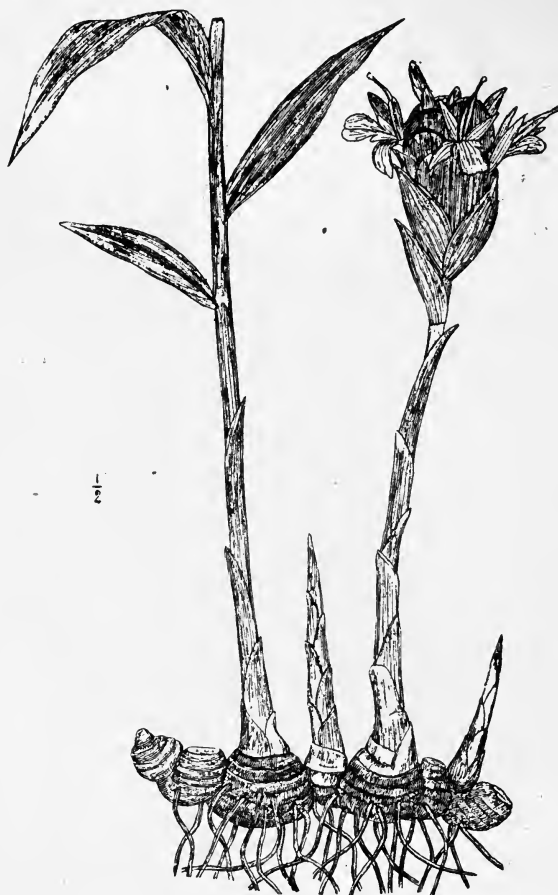

FIG. 169.—*Zingiber officinale*. (Sayre.)

ally attractive, entomophilous, arranged in elongated spikes or racemes, trimerous. Sepals, three usually similar; petals three of which two often resemble sepals, third is variously, often greatly



modified and fused with two outer petaloid stamens as a labellum or lighting-board for insects. Third stamen of outer whorl fertile (*Orchideæ*) or a barren knob (*Cypripediæ*); pollen of fertile anther agglutinate as pollinia. Three stamens of inner circle barren and petaloid or one absent (*Cypripediæ*). Stamens all epigynous and

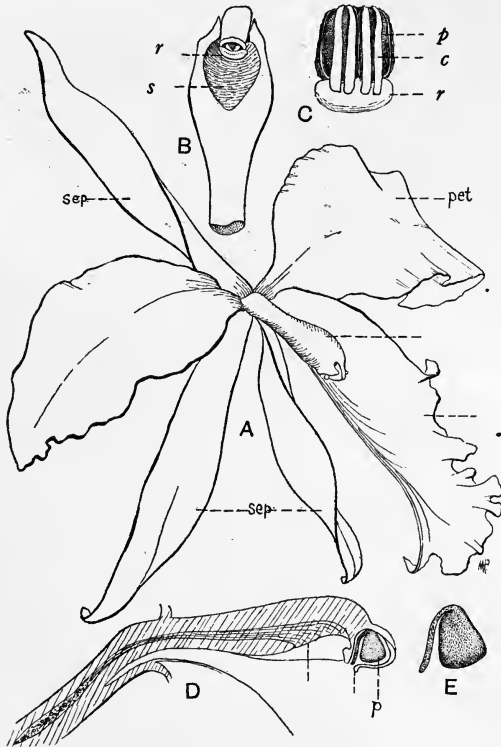

FIG. 170.—Floral organs of an orchid (*Cattleya* sp.). A, the entire flower; *sep*, sepal; *pet*, petal; B, column, showing *s*, stigma and *r*, the rostellum (beak), with the small glands at the tip; to the glands are attached the four strap-shaped caudicles of the pollinia; C, pollinia, with the four caudicles; below, the gland; D, longitudinal section of the column; *p*, pollinium; E, the same, enlarged. (Gager.)

often three are fused with the style as gynandrium. Carpels three, syncarpous, with inferior, three rarely four, one (usually)-celled ovary. Fruit a capsule, three-valved and one-celled. Seeds minute, abundant and wind disseminated.

| Official drug    | Part used         | Botanical name                 | Habitat       |
|------------------|-------------------|--------------------------------|---------------|
| Vanilla N.F.     | Fruit             | <i>Vanilla Planifolia</i>      | Mexico        |
| Cypripedium N.F. | Rhizome and roots | <i>Cypripedium hirsutum</i>    | United States |
|                  |                   | <i>Cypripedium parviflorum</i> |               |



FIG. 171.—*Vanilla planifolia*—Branch showing leaves and flowers. (Sayre.)

#### CLASS B.—DICOTYLEDONEÆ

Plants having the following characteristics:  
 Two-seed leaves (cotyledons) in embryo.  
 Netted-veined leaves.

Stems, and roots of secondary growth with open collateral fibrovascular bundles, radially arranged about pith.

Exogenous stems.

Medullary rays present.

Cambium.

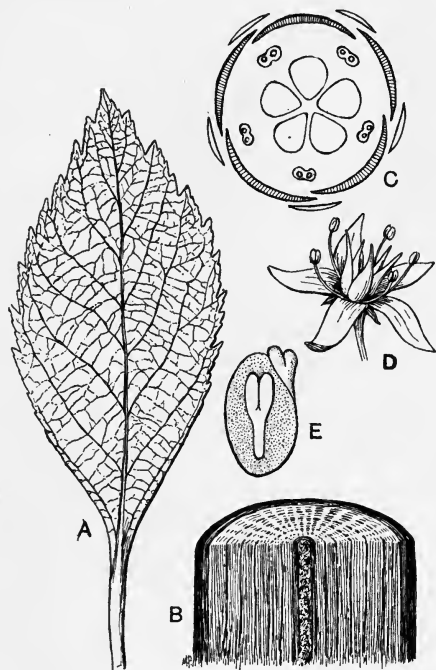

FIG. 172.—Morphology of a typical dicotyledonous plant. A, leaf, pinnately-netted veined; B, portion of stem, showing concentric layers of wood; C, ground-plan of flower (the parts in 5's); D, perspective of flower; E, longitudinal section of seed, showing dicotyledonous embryo. (*Gager.*)

Roots developing secondary structure.

Flowers tetra- or pentamerous (parts of each whorl, four or five or multiple thereof).

SUB-CLASS A.—ARCHICHLAMYDEÆ

Those dicotyledonous plants in which the petals are distinct and separate from one another or are entirely wanting. That group of

the Archichlamydeæ whose flowers show the absence of petals and frequently of sepals is called the Apetalæ. The group whose plants have flowers showing the parts of their corolla (petals) separate and distinct is called the Choripetalæ.



FIG. 173.—*Piper cubeba*—Fruiting branch and fruit (enlarged). (Sayre.)

I. Order Piperales.—*Piperaceæ* or *Pepper Family*.—A family of aromatic herbs and shrubs with jointed stems, opposite, verticillate, or sometimes alternate leaves without stipules, and spiked inconspicuous, wind-pollinated flowers. The characteristic fruit is a berry

enclosing a single upright seed with abundant perisperm (from megasporangial tissue) and reduced endosperm (from matured embryo sac).

| Official drug | Part used         | Botanical name             | Habitat                 |
|---------------|-------------------|----------------------------|-------------------------|
| Cubeba        | Unripe fruit      | <i>Piper Cubeba</i>        | Borneo, Java<br>Sumatra |
| Piper         | Unripe fruit      | <i>Piper nigrum</i>        | Cochin-China,<br>India  |
| Kava N.F.     | Rhizome and roots | <i>Piper methysticum</i>   | South Sea Islands       |
| Matico N.F.   | Leaves            | <i>Piper angustifolium</i> | Peru, Bolivia           |



FIG. 174.—Willow (*Salix*). Leafy branch, bearing two pistillate catkins, Staminate flower above, at the left; pistillate flower below, at the right. (Gager after Britton and Brown.)

**II. Order Salicales.**—*Salicaceæ* or *Willow Family*.—Shrubs or trees of temperate or cold regions, with upright woody stems. Bark often containing bitter principles (Salicin etc.).

Leaves alternate, simple, entire, stipulate; stipules rarely green, persistent, usually functioning as winter bud-scales and falling in spring.

Inflorescences diœcious spikes, so on separate plants. Staminate spikes forming deciduous catkins of yellowish flowers, pistillate as persistent spikes of green flowers, at length maturing fruit.

Flowers of catkins numerous, each of two to five (Willow) or six to fifteen (Poplar) stamens in axil of a small bract leaf, sometimes with small nectar knob or girdle at base; pollen abundant, hence plants anemophilous, rarely entomophilous. Pistillate flowers green, each of a bicarpellate pistil in axil of bract, ovary one-celled with parietal placentation, style simple, stigma bilobed.

Fruit a capsule dehiscent longitudinally. Seeds small, exalbuminous, surrounded by a tuft of hairs for dissemination.

| Official drug        | Part used        | Botanical name   | Habitat               |               |   |               |         |             |
|----------------------|------------------|--|-----------------------|---------------|---|---------------|---------|-------------|
| Salicin              | Glucoside        | Several species of Salix and Populus   | Europe, North America |               |   |               |         |             |
| Populi Gemmæ<br>N.F. | Closed leaf buds | <table border="0"> <tr> <td rowspan="3" style="font-size: 3em; vertical-align: middle;">{</td> <td>Populus nigra</td> <td rowspan="3" style="font-size: 3em; vertical-align: middle;">}</td> <td rowspan="3">North America</td> </tr> <tr> <td>Populus</td> </tr> <tr> <td>balsamifera</td> </tr> </table> | {                     | Populus nigra | } | North America | Populus | balsamifera |
| {                    | Populus nigra    | }  |                       | North America |   |               |         |             |
|                      | Populus          |  |                       |               |   |               |         |             |
|                      | balsamifera      |  |                       |               |   |               |         |             |
| Unofficial drug      |                  |  |                       |               |   |               |         |             |
| Salix                | Bark             | Salix alba   | Europe                |               |   |               |         |             |

III. Order **Myricales**.—*Myricaceæ* or *Bayberry Family*.—Dicecious or sometimes monœcious, aromatic shrubs or trees with watery juice and possessing underground branches which arch downward then upward producing many suckers. Roots fibrous and bearing many short rootlets upon which are frequently found coralloid clusters of tubercles containing the *Actinomyces Myricarum* Youngken. Leaves alternate, revolute in veneration, serrate, irregularly dentate, lobed or entire, rarely pinnatifid, pinnately and reticulately veined, pellucid punctate, evergreen or deciduous, generally exstipulate, rarely stipulate. Flowers naked, unisexual, monœcious or diœcious, in the axils of unisexual or androgynous aments from scaly buds formed in the summer in the axils of the leaves of the year, remaining covered during the winter and opening in March or April before or with the unfolding of the leaves of the year.

Staminate flowers in elongated catkins, each consisting of two to eight stamens inserted on the torus-like base of the oval to oval-lanceolate bracts of the catkin, usually subtended by two or four or rarely by numerous bracteoles; filaments short or elongated,

filiform, free or connate at the base into a short stipe; anthers ovoid, erect, two celled, extrorse, showing longitudinal dehiscence. Pistillate flowers in ovoid or ovoid-globular catkins. Gynæcium of two united carpels on a bract. Ovary sessile, unicellular, subtended by two lateral bracteoles which persist under the fruit, or by eight



FIG. 175.—Two *Myrica cerifera* trees growing in a field near a brackish swamp at Rio Grande, N. J. Photographed by author July 26, 1914.

linear subulate bracteoles, accrescent, and forming a lacinate involucre inclosing the fruit; styles short and dividing into two elongated style arms which bear stigmatic surfaces on their inner face; ovule orthotropous, solitary, with a basilar placenta and superior micropyle. Fruit an akene or ceriferous nut. Pericarp

covered with glandular emergences which secrete wax or fleshy emergences, smooth and lustrous or smooth, glandular. Seed



FIG. 176.—Fructiferous branches of *Myrica Caroliniensis* (to left) and *Myrica cerifera* (to right) as they appear in early winter. The former species is deciduous, while the latter is evergreen. Collected by author at Wildwood, N. J., Dec. 16, 1914.

erect, exalbuminous, covered with a thin testa. Embryo straight, cotyledons thick, plano-convex; radicle short, superior.

There are two distinct genera of this family, e.g., *Myrica* and *Comptonia*.



| Official drug | Part used    | Botanical name         | Habitat               |
|---------------|--------------|------------------------|-----------------------|
| Myrica N.F.   | Bark of root | <i>Myrica cerifera</i> | Eastern United States |



FIG. 177.—Fructiferous branch of *Myrica Gale*, showing mature pistillate catkins and nature of leaves. Collected at the south end of Peak's Island in Casco Bay, Maine, September, 1913.

IV. Order Juglandales.—JUGLANDACEÆ.—A family of apetalous exogenous trees—the walnut family—with alternate odd-pinnate leaves and monœcious flowers, the sterile in catkins, the fertile solitary or in a small cluster or spike. The fruit is a dry drupe with

a bony nut-shell and a four-lobed seed. It embraces five genera, of which *Carya* (Hicoria) and *Juglans* are represented in the United States, and about 35 species.

| Official drug | Part used       | Botanical name  | Habitat       |
|---------------|-----------------|-----------------|---------------|
| Juglans N. F. | Inner root bark | Juglans cinerea | United States |

*Betulaceæ* or *Birch Family*.—A family of aromatic trees or shrubs distinguished by monœcious flowers with scaly bracts and astringent resinous bark. Differs from *Fagaceæ* by superior ovary and absence of cupule. To this family belong the hazelnuts, birches, alders, the ironwood, and the hornbean.

| Official drug                        | Part used    | Botanical name | Habitat       |
|--------------------------------------|--------------|----------------|---------------|
| (Oleum Betulæ)<br>Methylis salicylas | Volatile oil | Betula lenta   | North America |

V. **Order Fagales**.—*Fagaceæ* or *Beech Family* (*Cupuliferæ*).—*Beeches*, *Chestnuts*, *Oaks*, the trees of this family are found in the temperate forests of the eastern and western hemispheres and comprise about 368 species. North America has over 50 species of oaks; 2 species of Chestnuts; 1 species of beech and 1 species of golden-leaved chestnut. The most important American oaks used for building, for furniture, for cooperage, for wagons, for tanning leather etc. are white oak, *Quercus alba*; chestnut oak, *Q. prinus*, black oak, *Q. velutina*; live oak, *Q. virginiana*; swamp white oak, *Q. platanoides*; cow oak, *Q. Michauxii*, and the two Pacific coast oaks, *Q. chrysolepis* and post oak, *Q. garryana*. The uses of the fast disappearing Chestnut, *Castanea dentata*, are well known. The wood of the beech, *Fagus grandifolia*, is used for chairs, tool handles, plane stocks, shoe lasts and for fuel. The nuts (mast) fatten hogs and feed wild animals and birds. The cork of commerce is obtained from the bark of *Quercus Suber* and *Quercus occidentalis*, plants indigenous to Spain and France.

The above trees are all monœcious, that is the staminate (male) and pistillate (female) flowers are distinct from each other, but borne on the same tree. Most of the species are trees, a few oaks are shrubs. The leaves are simple, netted-veined and alternate. A pair of deciduous stipules are found at the base of the leaf-stalk

(petiole). The margins of the chestnut and beech leaves are sharply cut with large teeth. The leaves of the oaks divide the genus into two groups, viz.—the white oaks with rounded lobed leaves and

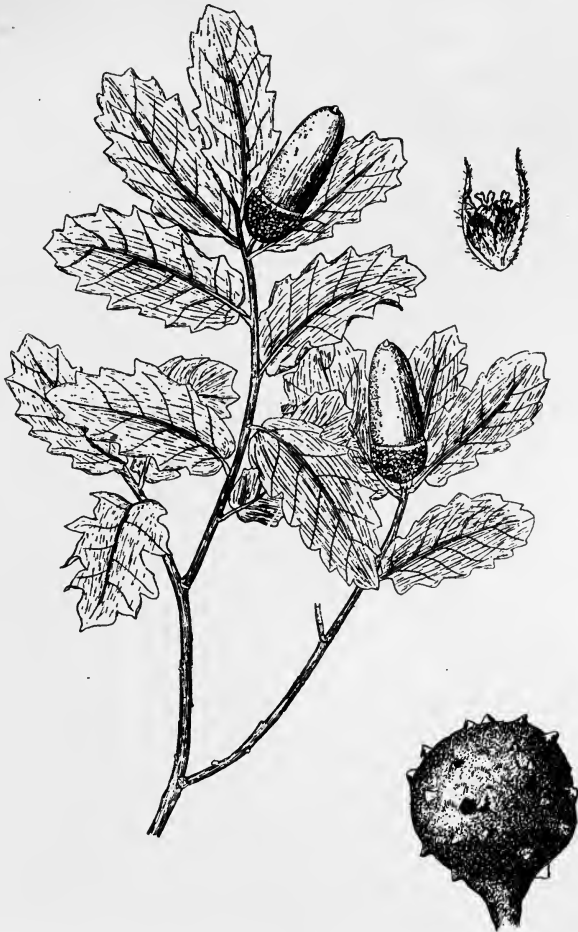

FIG. 178.—*Quercus infectoria*—Branch and nutgall. (Sayre.)

annual acorn production, and the black oaks with sharp bristle-tipped lobes and biennial acorn production. The male flowers are in dangling heads (beech), or in catkins (chestnut and oaks). The

male flowers have a united perianth, which is 4-6 parted and encloses an indefinite number of undivided stamens. The female



FIG. 179.—Hop (*Humulus lupulus*). A, portion of plant showing pistillate inflorescences; B, staminate inflorescence; C, rachis of pistillate inflorescence ("hop"). (Robbins.)

flowers have a superior 6-parted perianth; the pistil consisting of 3 carpels with a corresponding number of stigmas. The ovary is

3-6 celled and each cell has 2 pendulous ovules. The fruit is a one-seeded nut. The cup, or cupule, in the beech is 4 sided and covered externally with weak spines and encloses two 3 sided seeds. The cupule in the chestnut forms the spiny bur, which splits into 4 valves at maturity, enclosing 3 nuts. The cupule in the oak is saucer, or cup-shaped, and encloses a single rounded nut, or acorn. The seeds are exalbuminous and the cotyledons are thick and fleshy, edible in the beech, chestnut and a few of the oaks.

| Official drug | Part used   | Botanical name     | Habitat       |
|---------------|-------------|--------------------|---------------|
| Galla         | Excrescence | Quercus infectoria | Europe        |
| Castanea N.F. | Leaves      | Castanea dentata   | North America |
| Quercus N.F.  | Bark        | Quercus alba       | North America |

**VI. Order Urticales.**—*Ulmaceæ* or *Elm Family*.—Forest trees indigenous to the temperate and tropical zones, characterized by being woody plants, with pinnately-veined leaves and caducous stipules and without milky juice. Their flowers are unisexual or hermaphroditic with six or four parts to the perianth. Fruit a samara.

| Official drug | Part used  | Botanical name | Habitat                  |
|---------------|------------|----------------|--------------------------|
| Ulmus         | Inner bark | Ulmus fulva    | United States and Canada |

*Moraceæ* or *Mulberry Family*.—Mostly shrubs or trees, rarely herbs, perennials, many of them containing a milky juice, with small axillary, clustered or solitary unisexual flowers, variously colored; leaves ovate with serrate margin and having caducous stipules; fruit an akene enclosed by the perianth.

| Official drug  | Part used                          | Botanical name                 | Habitat                         |
|----------------|------------------------------------|--------------------------------|---------------------------------|
| Cannabis       | Flowering tops of pistillate plant | Cannabis sativa                | } Asia                          |
|                |                                    | Cannabis sativa<br>var. indica |                                 |
| Ficus N.F.     | Fruit                              | Ficus Carica                   | Persia                          |
| Humulus        | Strobile                           | Humulus lupulus                | { Europe, Asia<br>North America |
| Lupulinum N.F. | Glandular trichome                 | Humulus lupulus                |                                 |

**VII. Order Santalales.**—*Santalaceæ* or *Sandalwood Family*.—Herbs, shrubs or trees having entire exstipulate leaves, greenish

flowers and oily seeds. Many are parasitic on the roots of other plants:

| Official drug       | Part used    | Botanical name   | Habitat                 |
|---------------------|--------------|------------------|-------------------------|
| Oleum Santali       | Volatile oil | } Santalum album | { India and East Indies |
| Santalum Album N.F. | Heartwood    |                  |                         |

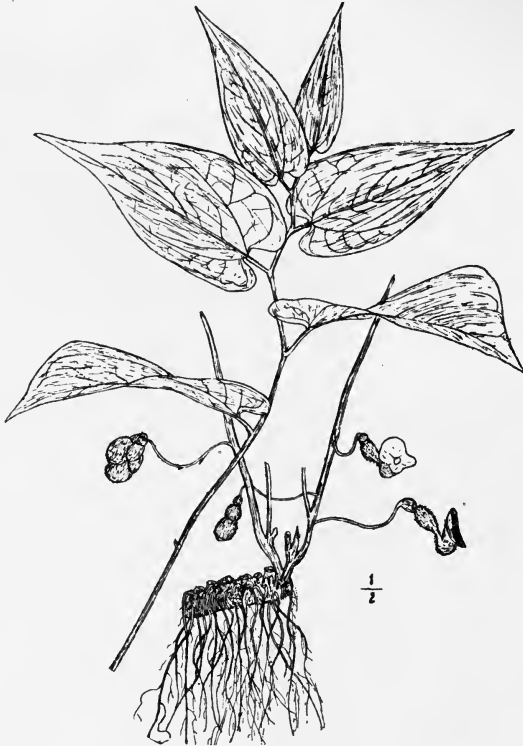

FIG. 180.—*Aristolochia serpentaria*. (Sayre.)

VIII. Order Aristolochiales.—*Aristolochiaceæ* or *Birthwort Family*.  
 —Herbs or twining semi-woody or woody plants, having more or less swollen nodes from which spring cordate or reniform or ovate leaves. Flowers regular (*Asarum*, etc.) or irregular (*Aristolochia*) often offensively smelling. Fruit a capsule. Seeds with copious albumen and minute embryo.

| Official drug | Part used         | Botanical name   | Habitat       |
|---------------|-------------------|--|---------------|
| Serpentaria   | Rhizome and roots | <div style="display: flex; align-items: center;"> <div style="font-size: 3em; margin-right: 5px;">}</div> <div style="margin-left: 5px;">           Aristolochia<br/>           Serpentina<br/>           Aristolochia<br/>           reticulata         </div> </div> | United States |
| Asarum N.F.   | Rhizome and roots | Asarum canadensis  | United States |

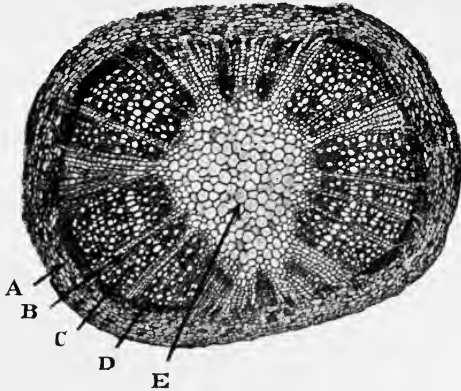

FIG. 181.—Serpentina—Cross-section of rhizome. (25 diam.) A, parenchyma of cortex; B, medullary ray; C, xylem; D, phloem; E, medulla. (Sayre.)

**IX. Order Polygonales.**—*Polygonaceæ* Family.—Usually herbs (*Polygonum*, *Rumex*, etc.) rarely trees (*Coccoloba uvifera* and *C. platyclada*) or shrubs (*Muhlenbeckia*, *Brunnichia*) having strong vertical tap roots and spreading secondary roots more or less provided with tannin compounds. Stems elongate, green, to woody, rarely flattened, leathery, phylloidal (*Muhlenbeckia platyclada*) still more rarely tendriform (*Antigonum leptopus*). Leaves alternate rarely opposite or whorled (*Eriogonum*), entire, rarely lobed (*Rheum palmatum*, *Rumex acetosella*), petiolate, rarely sessile, and stipulate. Stipules fused and forming a greenish membranous upgrowth (*ocrea*) which sheaths the stem. Inflorescence racemose with many dense scorpioid or helicoid cymes, which in some forms condense into single flowers. Flowers regular, pentamerous, with simple calyx, becoming trimerous with two whorls of three sepals each. Stamens varying from fifteen or twelve to nine or six more rarely to five, four, three to one (*Kanigia*), hypogynous, more

rarely by enlargement of receptacle and slight fusion of sepals, perigynous. Pistil tri- to bicarpellate often three- to two-sided, ovary one-celled with one ovule. Styles three, rarely two, radiating penicillate in wind-pollinated inconspicuous flowers, becoming condensed knob-like in conspicuous insect-pollinated flowers. Fruit a triangular or biconvex akene often crowned by persistent styles and surrounded by persistent closely applied sepals. Seeds solitary, albuminous, with straight embryo, or in *Rumex*, curved embryo.

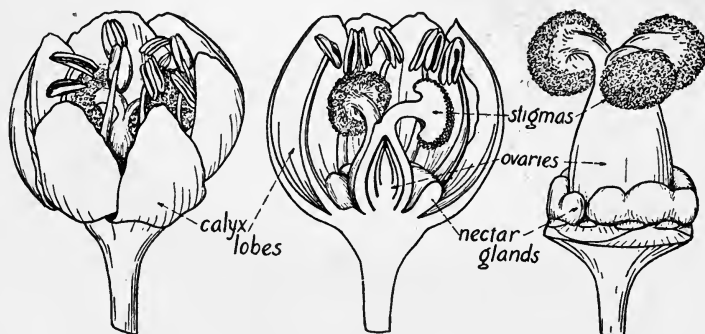

FIG. 182.—Rhubarb (*Rheum*) flower, external view, median lengthwise section, and with perianth and stamens removed. (*Robbins, after Lürssen.*)

| Official drug     | Part used | Botanical name   | Habitat          |
|-------------------|-----------|--|------------------|
| Rheum             | Rhizome   | Rheum officinale   | China and Thibet |
|                   |           | Rheum palmatum and the variety tanguticum and probably other species |                  |
| Rumex N.F.        | Root      | Rumex crispus  | Europe           |
|                   |           | Rumex obtusifolius   |                  |
|                   |           |  |                  |
| <b>Unofficial</b> |           |  |                  |
| Bistorta          | Rhizome   | Polygonum Bistorta   | Europe and Asia  |

**X. Order Chenopodiales** (*Centrosperma*).—*Chenopodiaceæ* or *Goosefoot Family*.—Usually herbaceous halophytes or shore growers,



growing also in any alkaline soil, more rarely shrubs (*Atriplex*) or low trees (*Haloxylon*).

Among them are several garden vegetables (*Spinach*, *Beets*, *Mangels*) and a number of weeds. Leaves alternate to opposite sometimes reduced to teeth, entire or lobed. Inflorescence spikes



FIG. 183.—*Phytolacca decandra* (in foreground), growing in damp woodland.

or short racemes of condensed cymes. Flowers regular, usually small and greenish. They are either perfect (*Beta*), monœcious (*Chenopodium*), dioecious (*Atriplex* sp.), or polygamous (*Kochia*). Fruit a utricle. Seed albuminous.

| Official drug                    | Part used     | Botanical name                | Habitat       |
|----------------------------------|---------------|-------------------------------|---------------|
| Oleum Chenopodii                 | Volatile oil  | Chenopodium<br>anthelminticum | United States |
| Saccharum                        | Refined sugar | Beta vulgaris                 | Europe        |
| <b>Unofficial</b><br>Chenopodium | Fruit         | Chenopodium<br>anthelminticum | United States |

*Phytolaccaceæ*.—A family of apetalous trees, shrubs, or woody herbs—the pokeweed family—with alternate entire leaves, and flowers resembling those of the goosefoot family (*Chenopodiaceæ*), but differing in having the several-celled ovary composed of carpels united in a ring, and forming a berry in fruit. It embraces 21 genera, and 55 species, tropical and sub-tropical.

| Official drug   | Part used | Botanical name         | Habitat       |
|-----------------|-----------|------------------------|---------------|
| Phytolacca N.F. | Root      | Phytolacca<br>decandra | North America |

**XI. Order Ranales.**—*Magnoliaceæ* or *Magnolia Family*.—Trees and shrubs having alternate leaves and single large flowers with calyx and corolla colored alike. Sepals and petals deciduous, anthers adnate. Carpels and stamens numerous. Bark aromatic and bitter. Fruit a collection of follicles dehiscing dorsally.

| Official drug                      | Part used    | Botanical name | Habitat       |
|------------------------------------|--------------|----------------|---------------|
| Oleum anisi                        | Volatile oil | Illicium verum | South China   |
| <b>Unofficial</b><br>Winter's Bark | Bark         | Drimys Winteri | South America |

*Ranunculaceæ* or *Buttercup Family*.—Herbs, rarely shrubs (*Clematis*) with acrid, poisonous, watery juices and with alternate, rarely opposite, simple, rarely compound, exstipulate leaves. Flowers pentamerous, regular to irregular, incomplete to complete, aposepalous and apopetalous. Sepals five—rarely more or less—green to petaloid, regular, passing to irregular (Larkspur, Monkshood). Petals none or five, regular to rarely irregular, often nectariferous and with nectariferous petals often variously transformed. Stamens indefinite, hypogynous. Pistil of many to few apocarpous carpels, each carpel with one to several ovules. Fruit a collection of achenes (*Ranunculus*, *Anemonella*), or a collection of follicles

(Columbine, Larkspur, Peony) or rarely a berry as in Baneberry (*Actæa*). Seeds albuminous.



FIG. 184.—Above ground portion of *Aconitum Napellus* showing palmately-divided leaves and hooded flowers.

| Official drug | Part used         | Botanical name                 | Habitat                             |
|---------------|-------------------|--------------------------------|-------------------------------------|
| Hydrastis     | Rhizome and roots | <i>Hydrastis canadensis</i>    | Eastern United States and Canada    |
| Aconitum      | Tuberous root     | <i>Aconitum Napellus</i>       | Europe, Asia, Western North America |
| Staphisagria  | Seed              | <i>Delphinium Staphisagria</i> | South Europe, Asia Minor            |
| Cimicifuga    | Rhizome and root  | <i>Cimicifuga racemosa</i>     | North America, Europe, Asia         |



FIG. 185.—*Cimicifuga racemosa*—Plant and rhizome. Note the pinnately decompound leaf and the wand-like racemes which bear white flowers. (Sayre.)

| Official drug     | Part used                 | Botanical name   | Habitat                                   |
|-------------------|---------------------------|--|---|
| Pulsatilla N.F.   | Entire herb               | { Anemone<br>Pulsatilla<br>Anemone<br>Ludoviciana<br>Anemone pratensis } | { Europe                                  |
| Coptis N.F.       | Entire herb               | Coptis trifolia  | United States and<br>Canada               |
| Adonis N.F.       | Entire herb               | Adonis vernalis  | Europe                                    |
| Delphinium N.F.   | Seeds                     | { Delphinium<br>Consolida<br>Delphinium<br>Ajacis }                      | { Europe                                  |
| <b>Unofficial</b> |                           |  |   |
| Aconiti Folia     | Leaves and flower<br>tops | Aconitum<br>Napellus   | Europe, Asia,<br>western North<br>America |
| Helleborus        | Rhizome and roots         | Helleborus niger   | Alps                                      |

*Berberidaceæ* or *Barberry Family*.—Herbs and woody plants with watery juices and alternate, or radical, simple or compound leaves often bearing spines or barbs, which give them a barbed appearance. Fruit a berry or capsule.

| Official drug        | Part used         | Botanical name                                | Habitat                  |
|----------------------|-------------------|---|--------------------------|
| Berberis N.F.        | Rhizome and roots | Berberis species of<br>the Sect.<br>Odostemon | Western North<br>America |
| Podophyllum          | Rhizome and roots | Podophyllum<br>peltatum                       | Eastern North<br>America |
| Caulophyllum<br>N.F. | Rhizome and roots | Caulophyllum<br>thalictroides                 | Eastern United<br>States |

*Menispermaceæ*, or *Moonseed Family*.—Choripetalous woody, climbing, tropical plants with alternate, exstipulate, simple often peltate leaves. Flowers green to white. Fruit a one-seeded succulent drupe. Seeds albuminous. They usually contain tonic, narcotic or poisonous bitter principles.



FIG. 186.—*Podophyllum peltatum*. Entire plant, above ground portion, and fruit. Note the flowering stems bearing in each instance two one-sided leaves and a nodding flower from the forks. This plant also sends up from its rhizome flowerless stems each of which terminates in a 7-9 lobed peltate leaf.

| Official drug     | Part used         | Botanical name                  | Habitat                  |
|-------------------|-------------------|---------------------------------|--------------------------|
| Calumba           | Root              | <i>Jateorhiza palmata</i>       | East Africa              |
| Pareira N.F.      | Root              | <i>Chondodendron tomentosum</i> | Peru and Brazil          |
| Cocculus N.F.     | Fruit             | <i>Anamirta cocculus</i>        | Asia                     |
| <b>Unofficial</b> |                   |                                 |                          |
| Menispermum       | Rhizome and roots | <i>Menispermum canadense</i>    | United States and Canada |

*Myristicaceæ* or *Nutmeg Family*.—An order of apetalous trees comprising the single genus *Myristica*, of about 80 species.

*Myristica*.—A large tropical genus of fragrant, apetalous trees—the nutmegs—coextensive with the nutmeg family, having alternate,



FIG. 187.—*Jateorhiza palmata*—Portion of vine. Note tendril for winding about a support as this plant climbs. (Sayre.)

entire, often punctate leaves, small dicœious regular flowers, and a succulent, two-valved, one-celled fruit with a solitary seed, usually covered by a fleshy arillus.

*M. fragrans*, a handsome tree, 20 to 30 feet high, of the Malay archipelago, supplies the nutmegs and mace of commerce.

| Official drug   | Part used      | Botanical name            | Habitat           |
|-----------------|----------------|---------------------------|-------------------|
| Myristica       | Kernel of seed | <i>Myristica fragrans</i> | } Molluca Islands |
| Oleum Myristicæ | Volatile oil   | <i>Myristica fragrans</i> |                   |
| Macis N.F.      | Arillode       | <i>Myristica fragrans</i> |                   |



FIG. 188.—*Myristica fragrans*—Branch and fruit. (Sayre.)

*Lauraceæ* or *Spicebush Family*.—Shrubs or trees of sub-tropical or tropical, rarely of temperate regions. Bark, wood and leaves rich in spicy aromatic hydrocarbon oils. Leaves alternate, simple, entire, often leathery shining. Inflorescences usually cymose clus-



ters. Flowers small, green, yellow or rarely whitish, hermaphrodite or more or less dioecious, regular calyx alone present as a floral whorl, of three to six small sepals. Stamens four to twelve in several rows of three to four each; anthers opening by recurved valves (valvular



FIG. 189.—*Cinnamomum zeylanicum*—Branch. (Sayre.)

dehiscence). Pistil monocarpilary, ovary superior one-celled with solitary pendulous ovule, style simple with usually rounded stigma. Fruit a succulent berry (Spicebush and "Bacca laurea") or a succulent drupe (Sassafras).

| Official drug             | Part used      | Botanical name                         | Habitat                 |
|---------------------------|----------------|--|-------------------------|
| Camphora                  | Ketone         | Cinnamomum<br>Camphora                 | Eastern Asia            |
| Sassafras                 | Bark of root   | Sassafras<br>variifolium               | North America           |
| Sassafras Medulla<br>N.F. | Pith           | Sassafras<br>variifolium               | North America           |
| Cinnamomum<br>Zeylanicum  | Bark           | Cinnamomum<br>Zeylanicum               | Ceylon                  |
| Cinnamomum<br>Saigoncum   | Bark           | Undetermined<br>species of<br>cinnamon | China                   |
| Oleum Cinnamomi           | Volatile oil   | Cinnamomum<br>cassia                   | China                   |
| <b>Unofficial</b>         |                |  |                         |
| Coto                      | Bark           | Sp. undetermined                       | Bolivia                 |
| Laurus                    | Leaves         | Laurus nobilis                         | Europe<br>North America |
| Fagot cassia              | Bark           | Cinnamomum<br>Burmanii                 | Asia                    |
| Clove Bark                | Bark           | Dicypellium<br>caryophyllatum          | Brazil                  |
| Cassia Buds               | Immature fruit | Cinnamomum<br>Loureirii                | China                   |

**XII. Order Rhœadales (Papaverales).**—*Papaveraceæ* or *Poppy Family*.—Herbs or low shrubs. Root only, in some cases root and stem, and in still others the entire plant, traversed by anastomosing latex tubes that contain a milky juice varying from white (*Papaver*) or pale-yellow (*Chelidonium*) to red (*Bloodroot*). Latex tubes wholly confined to cortex or phloem but occasionally sending branches into the medullary rays, rarely into the pith of the plant. Leaves alternate varying from simple (*Platystemon*) to pinnatifid, pinnatipartite or even pinnately compound. Inflorescence varying from a loose raceme or panicle of cymes to a raceme of cymes or condensing until, as in *Papaver*, only one large terminal flower is left. Flowers regular, tetramerous or dimerous. Sepals typically two more rarely three. Petals typically four, more rarely six. Stamens indefinite in most forms hypogynous except in California Poppy (*Eschscholtzia*) where hypogyny is modified into perigyny. Pistil of sixteen to four, rarely two carpels generally fused together. Placenta parietal. Ovules

numerous, anatropous, Fruit a capsule except in *Platystemon* which has follicles. Seeds richly albuminous.



FIG. 190.—*Papaver Somniferum*—Flowering branch and fruit. (Sayre.)

| Official drug     | Part used               | Botanical name                                      | Habitat                         |
|-------------------|-------------------------|---|---------------------------------|
| Opium             | Air-dried milky exudate | <i>Papaver somniferum</i> and its <i>var. album</i> | Eastern Mediterranean countries |
| Sanguinaria       | Rhizome and roots       | <i>Sanguinaria canadensis</i>                       |                                 |
| <b>Unofficial</b> |                         |   |                                 |
| Chelidonium       | Entire flowering plant  | <i>Chelidonium majus</i>                            | United States and Canada        |
| Maw seed          | Seeds                   | <i>Papaver somniferum album</i>                     | <i>vide supra</i>               |

*Fumariaceæ* or *Fumitory Family*.—Delicate herbs rarely shrubs containing milky watery to watery latex. Leaves more or less compound. Inflorescence a raceme or spike. Flowers irregular, zygomorphic, one or both of the petals of which having a spur. Fruit a one-chambered capsule. Seeds albuminous. Idioblasts common.

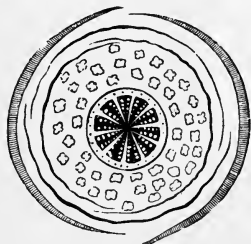

FIG. 191.—Transverse section of flower of Poppy. (Sayre.)



FIG. 192.—Gynecium of Poppy, with one stamen remaining. (Sayre.)

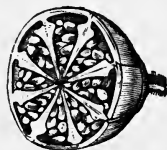

FIG. 193.—Transverse section of ovary of Poppy. (Sayre.)

| Official drug  | Part used  | Botanical name | Habitat                     |
|----------------|--|----------------|-----------------------------|
| Corydalis N.F. | Tubers of <i>Dicentra</i> ( <i>Bicuculla</i> )<br><i>canadensis</i><br>Bulbs of <i>Dicentra Cucullaria</i> |                | United States and<br>Canada |

*Cruciferae* or *Mustard Family*.—Herbs, rarely shrubs, mostly of temperate regions. Stem and branches upright or diffuse spreading (*Arabis*). Leaves alternate, simple rarely compound, exstipulate, entire or toothed, often more or less hairy. Inflorescence at first a corymb or shortened raceme, later elongating into a loose raceme. Bracts at base rarely reduced, usually absent. Flowers regular—rarely irregular (Candytuft)—tetramerous. Sepals four, green, equal or two laterals, at times pouched as nectar receptacles. Petals four, yellow to white or to pink or purple, cruciform, often divisible into claw and blade. Stamens six to four long anteroposterior, two short lateral and often with nectar knobs or discs, hence termed tetradynamous, insertion hypogynous. Pistil syncarpous bicarpellate, superior, carpels lateral. Ovary one-celled but falsely two-celled by a placental replum, style simple, stigma rounded or bifid or bilobed. Ovules several, rarely few, attached to marginal

placenta. Fruit a capsule—rarely indehiscent—bursting lengthwise by two valves. Seeds exalbuminous.

| Official drug   | Part used | Botanical name | Habitat         |
|-----------------|-----------|----------------|-----------------|
| Sinapis Alba    | Seed      | Sinapis alba   | Europe and Asia |
| Sinapis Nigra   | Seed      | Brassica nigra | Europe and Asia |
| Unofficial drug |           |                |                 |
| Semenæ Rapæ     | Seed      | Brassica napus | Europe and Asia |



FIG. 194.—*Brassica nigra*—Branch. (Sayre.)

XIII. Order Sarraceniales.—*Droseraceæ* or *Sundew Family*.—Herbs (*Drosera*, *Dionaea*, etc.) rarely shrubs (*Roridula* of South Africa), growing in bogs or swamps or purely aquatic in habit (*Aldrovanda*). Leaves, either rosettes or more or less scattered in alternate fashion over stem, usually glandular-hairy or sensitive-hairy and insectivorous. Inflorescence a loose raceme or cymose

umbel. Flowers regular, pentamerous; sepals five, aposepalous green; petals apopetalous, varying from white to whitish-pink, pink scarlet, purple to bluish-purple; stamens varying from fifteen to five hypogynous pistil syncarpous of five to three, rarely fewer carpels. Fruit a capsule. Seeds albuminous.

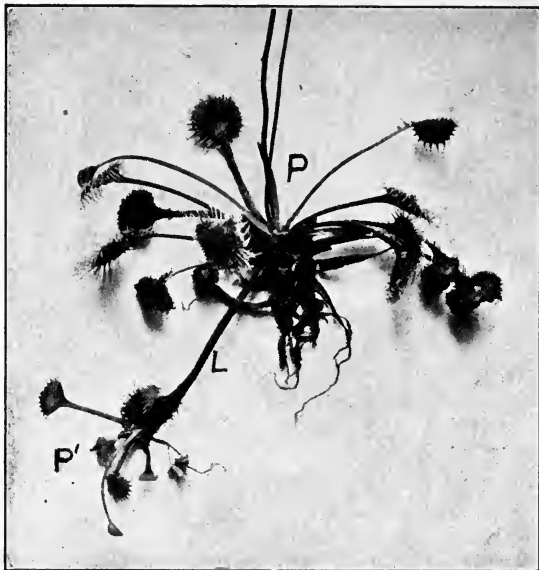

FIG. 195.—*Drosera rotundifolia*. Production of a young plant from the leaf of an older plant. (Gager.)

| Official drug | Part used    | Botanical origin  | Habitat                         |
|---------------|--------------|---|---------------------------------|
| Drosera N.F.  | Entire plant | {<br><i>Drosera rotundifolia</i><br><i>Drosera intermedia</i><br><i>Drosera longifolia</i><br>} | Eastern and western Hemispheres |

XIV. Order Rosales.—*Saxifragaceæ* or *Saxifrage Family*.—Herbs (*Saxifraga*, *Mitella*, etc.) or shrubs (*Hydrangea*, *Ribes*, *Philadelphus*, etc.) rich in tannin content, with opposite or alternate leaves usually devoid of stipules. Both stamens and petals are generally inserted on the calyx. Fruit a follicle, capsule, or berry. Seeds with copious albumen.

| Official drug  | Part used         | Botanical name           | Habitat       |
|----------------|-------------------|--------------------------|---------------|
| Hydrangea N.F. | Rhizome and roots | Hydrangea<br>arborescens | United States |

*Hamamelidacæ* or *Witchazel* Family.—Shrubs or small or large trees. Leaves, simple, alternate and pinnately veined; stipules deciduous to caducous, paired and slightly fused at the bases of



FIG. 196.—*Liquidambar orientalis*—Branch. (Sayre.)

petioles. Flowers frequently yellow to yellowish-white, in axillary clusters or heads or spikes, hermaphrodite or monœcious; sepals and petals five to four rarely indefinite, superior (petals absent in *Fothergilla*); stamens twice as many as the petals but the outer row alone fertile, the inner row being more or less barren and scale-like; gynœcium of two carpels united below. Fruit a two-beaked, two-

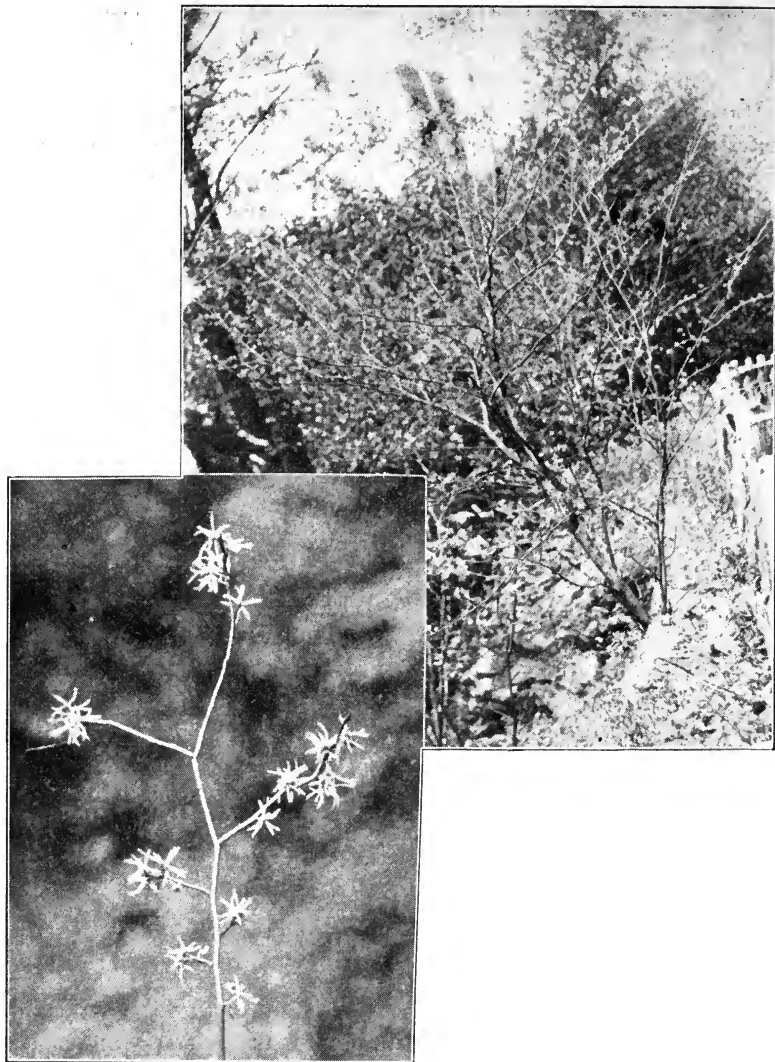

FIG. 197.—*Hamamelis virginiana*. Upper figure shows this shrub as it appears in autumn after the leaves have fallen. Note that the plant is in blossom. Lower figure shows a flowering branch from the same plant. The bright yellow flowers occur in axillary clusters appearing at the same time as the ripening of fruits from blossoms of the previous year.



celled woody capsule dehiscing at the summit, with a bony seed in each cell, or several, only one or two of them ripening.

| Official drug          | Part used                       | Botanical name         | Habitat                  |
|------------------------|---------------------------------|------------------------|--------------------------|
| Styrax                 | Balsam from wood and inner bark | Liquidambar orientalis | The Levant               |
| Hamamelidis Folia N.F. | Leaves                          | Hamamelis virginiana   | United States and Canada |

*Rosaceæ* or *Rose Family*.—Herbs, shrubs, or trees mostly of temperate regions. Stem and branches upright or creeping (Strawberry, Cinquefoil), herbaceous to woody. Leaves alternate, stipulate (stipules green persistent to scaly deciduous), compound condensing to "simple." Flowers regular, pentamerous; sepals and petals five—rarely four—inferior to ovary becoming by stages superior to it. Sepals green—at times with epicalyx (Strawberry, Cinquefoil, etc.), persistent round fruit. Petals usually yellow to white or to pink, crimson, rarely purple, rosaceous, deciduous. Stamens indefinite, perigynous (Strawberry, etc.), to semi-epigynous (Rose, Peach, etc.), and epigynous (Apple, Pear). Pistil apocarpous with many (Strawberry, Rose) carpels or fewer to five (Apple), or two to one (Plum, Cherry), becoming falsely fused by union with up-growing receptacle (Hawthorn, Apple). Fruit a collection of achenes on dry (Cinquefoil) or succulent receptacle (Strawberry), or dry follicles (Bridal Wreath), or drupels (Blackberry), or a drupe (Peach, Plum, Cherry), or a pome (Apple, Pear). Seeds exalbuminous embryo filling seed cavity.

| Official drug     | Part used                      | Botanical name                                     | Habitat                  |
|-------------------|--------------------------------|--|--------------------------|
| Amygdala Dulcis   | Seed                           | Prunus amygdalus variety dulcis                    | Asia                     |
| Prunus Virginiana | Bark                           | Prunus serotina                                    | United States and Canada |
| Rubus N.F.        | Bark of rhizome                | Rubus villosus, R. cuneifolius, and R. nigrobaccus | United States            |
| Quillaja N.F.     | Bark                           | Quillaja Saponaria                                 | Chile and Peru           |
| Brayera N.F.      | Panicles of pistillate flowers | Hagenia abyssinica                                 | Abyssinia                |
| Rosa Gallica      | Petals                         | Rosa gallica                                       | Southern Europe          |

| Official drug             | Part used      | Botanical name                             | Habitat                      |
|---------------------------|----------------|--|------------------------------|
| Rubi Fructus<br>N.F.      | Fresh fruit    | Rubus nigrobaccus<br>and Rubus<br>villosus | United States                |
| Succus Pomorum<br>N.F.    | Juice of Fruit | Pyrus Malus<br>(cultiv. var's.)            | Cultivated                   |
| Rubi Idæi<br>Fructus N.F. | Juice of Fruit | Rubus Idæus and<br>Rubus strigosus         | Europe and Asia              |
| Prunum N.F.               | Fruit          | Prunus domestica                           | Southern Europe              |
| Amygdala Amara            | Seed           | Prunus amygdalus<br>var. amara.            | Asia Minor, Persia,<br>Syria |



FIG. 198.—*Quillaja saponaria*—Branch. (Sayre.)

| Unofficial drug | Part used      | Botanical name               | Habitat           |
|-----------------|----------------|------------------------------|-------------------|
| Cydonium        | Seed           | <i>Cydonia vulgaris</i>      | Cultivated widely |
| Rosa Centifolia | Petals         | <i>Rosa centifolia</i>       | Western Asia      |
| Rosa Canina     | Spurious Fruit | <i>Rosa canina</i>           | Europe            |
| Tormentilla     | Rhizome        | <i>Potentilla silvestris</i> | Europe and Asia   |



FIG. 199.—*Prunus domestica*—Fruiting branch and flowering branch. (Sayre.)

*Léguminosæ* or Pea Family (*Fabacæ*).—Herbs, shrubs or trees of all regions, with tubercled roots. Stem usually erect, rarely creeping (*Trifolium repens*). Leaves alternate, compound—rarely simple—stipulate, sometimes tendriform or reduced to phylloid petioles (*Acacia* sp.). Inflorescence a raceme, at times, condensed almost to a head or capitulum (Sp. of clover, *Mimosa*, etc.). Flowers pentamerous (rarely four), regular (*Mimoseæ*), to irregular (*Cæsalpineæ*, *Papilionacæ*). Sepals five united, green; petals five (rarely four) variously related, in *Papilionacæ* one superior, external, posterior—standard or vexillum, two lateral forms wings or alæ, two inferior internal and anterior slightly adherent form keel. Stamens

ten to four, free or in Papilionaceæ united by filaments into a monadelphous (ten) or a diadelphous (nine to one) tube, inserted perigynously. Pistil monocarpellary; ovary with sutural placentation, style simple. Seeds exalbuminous.



FIG. 200.—*Glycyrrhiza glabra*—Branch. (Sayre.)

| Official drug | Part used       | Botanical name  | Habitat |
|---------------|-----------------|---|---------|
| Acacia        | Gummy exudation | Acacia Senegal<br>and other African<br>species        | Africa  |
| Tragacantha   | Gummy exudation | Astragalus gum-<br>mifer and other<br>Asiatic species | Asia    |

| Official drug       | Part used         | Botanical name           | Habitat                   |
|---------------------|-------------------|--------------------------|---------------------------|
| Balsamum Peruvianum | Balsam            | Toluifera Pereiræ        | Central America           |
| Balsamum Tolutanum  | Balsam            | Toluifera Balsamum       | Columbia                  |
| Hæmatoxylon N.F.    | Heartwood         | Hæmatoxylon campechianum | Central America           |
| Santalum Rubrum     | Heartwood         | Pterocarpus santalinus   | Indo China                |
| Glycyrrhiza         | Rhizome and roots | Glycyrrhiza glabra       | Spain and France          |
|                     |                   | Glycyrrhiza glandulifera | Southwestern Asia, Russia |
| Senna               | Leaflets          | Cassia acutifolia        | Egypt                     |
|                     |                   | Cassia angustifolia      | Arabia and India          |
| Cassia Fistula N.F. | Fruit             | Cathartocarpus fistula   | India                     |

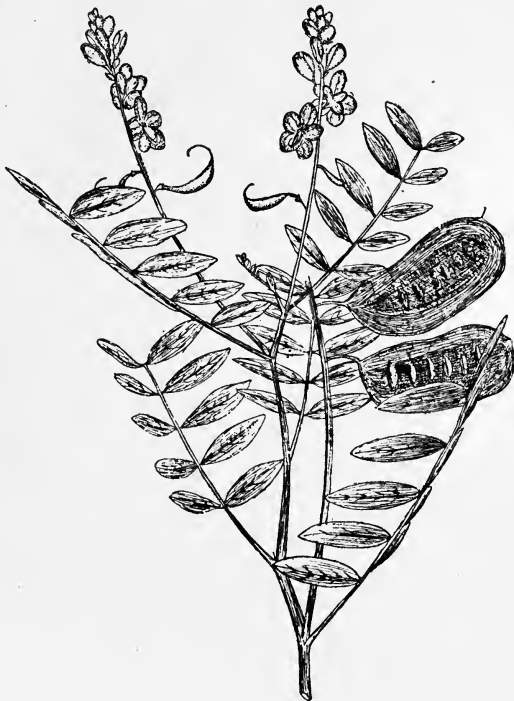

FIG. 201.—*Cassia acutifolia*—Branch showing flower and fruit. (Sayre.)

| Official drug     | Part used                      | Botanical name             | Habitat                              |
|-------------------|--------------------------------|----------------------------|--------------------------------------|
| Tamarindus N.F.   | Pulp of fruit                  | Tamarindus indica          | Tropical Africa                      |
| Copaiba           | Oleoresin                      | Copaiba species            | South America                        |
| Chrysarobinum     | Neutral principle              | Vouacapoua<br>Araroba      | Brazil                               |
| Physostigma       | Seed                           | Physostigma<br>venenosum   | Africa                               |
| Kino              | Inspissated juice              | Pterocarpus<br>Marsupium   | India and Ceylon                     |
| Scoparius N.F.    | Tops                           | Cytisus scoparius          | Europe                               |
| Trifolium N.F.    | Inflorescence                  | Trifolium pratense         | United States                        |
| Galega N.F.       | Flowering tops                 | Galega officinalis         | Southern Europe                      |
| Baptisia N.F.     | Roots                          | Baptisia tinctoria         | Eastern United States and<br>Canada  |
| Krameria N.F.     | Root                           | Krameria triandra          | Peru and Bolivia                     |
|                   |                                | Krameria Ixina             | United States of<br>Colombia, Brazil |
|                   |                                | Krameria argentea          | Brazil                               |
| <b>Unofficial</b> |                                |                            |                                      |
| Fœnum græcum      | Seed                           | Trigonella<br>Fœnum-græcum | Mediterranean<br>region              |
| Piscidia          | Bark                           | Piscidia Erythrina         | West Indies                          |
| Indigo            | Coloring matter                | Indigofera tinctoria       | India                                |
| Melilotus         | Leaves and flower-<br>ing tops | Melilotus officinalis      | Europe                               |
| Soy Bean          | Seeds                          | Glycine hispida            | United States and<br>Europe          |
| Abrus             | Seeds                          | Abrus precatorious         | Tropics and sub-<br>tropics          |
| Catechu           | Extract                        | Acacia Catechu             | India                                |
| Mucuna            | Hairs from fruits              | Mucuna pruriens            | East and West<br>Indies              |

**XV. Order Geraniales (Gruinales).—Geraniaceæ or Geranium Family.**—Herbaceous, rarely semi-succulent sub-shrubby plants. Stems cylindrical, often hairy or glandular hairy. Leaves alternate, to opposite, stipulate; venation from pinnate to palmate, so leaf shape from ovate to pinnatifid to pinnatipartite to sub-palmatifid to palmatifartite to compound palmate. Inflorescence either a dichel-  
sial or scorpioid cyme. Flowers regular pentamerous (*Geranium*)

to irregular pentamerous (*Pelargonium*); sepals five, aposepalous; petals five, apopetalous, varying in color from greenish-white or pink-red to scarlet, scarlet-crimson to crimson-purple; stamens with anthers ten or five, hypogynous or inserted into slightly developed hypogynous disc; pistil pentacarpellary, ovary five-celled with two,



FIG. 202.—*Physostigma venenosum*—Portion of plant and fruit. (Sayre.)

rarely one ovule in each cell, styles elongate, fused round a styler column of receptacle then continued as a styler tip which splits into five stigmatic surfaces. Fruit a regma rarely a simple capsule. Regma splits into five recurved carpels, each then dehiscent to set free two or one seeds. Seeds exalbuminous.

| Official drug               | Part used    | Botanical name               | Habitat                  |
|-----------------------------|--------------|------------------------------|--------------------------|
| Geranium N.F.<br>Unofficial | Rhizome      | Geranium maculatum           | North America.           |
| Oil of Rose<br>Geranium     | Volatile oil | Pelargonium<br>odoratissimum | Mediterranean<br>regions |
|                             |              | Pelargonium Radula           |                          |
|                             |              | Pelargonium<br>capitatum     |                          |



FIG. 203.—*Linum usitatissimum*. (Sayre.)

*Linaceæ* or *Flax Family*.—Herbs with slender stems and alternate, simple, narrow leaves. Inflorescence cymose with regular pentamerous flowers; pistil five-carpelled with a five-celled ovary containing two ovules in each cavity and having a single style with knob-like stigma. While the flower is still in bud condition or soon after, there commences an ingrowth of the mid-rib of each carpel



which proceeds until, when plant is in fruit, there are formed 10 cavities each enclosing a seed. Seeds, anatropous, mucilaginous, flattened, containing a large embryo and slight albumen.

| Official drug | Part used | Botanical name      | Habitat           |
|---------------|-----------|---------------------|-------------------|
| Linum         | Seeds     | Linum usitatissimum | Temperate regions |
| Oeum Lini     | Fixed oil | Linum usitatissimum |                   |

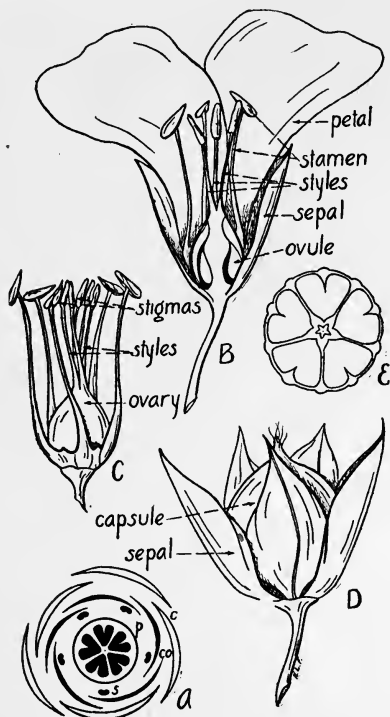

FIG. 204.—Flax. A, floral diagram—*c*, calyx; *co*, corolla; *s*, stamens; *p*, pistil. B, median lengthwise section of flower. C, calyx and corolla removed. D, fruit, external view. E, cross-section of fruit. (Robbins.)

*Erythroxylaceæ* or *Coca Family*.—Shrubs (*Erythroxylon*) or trees with alternate, simple, entire, glabrous and pinnately veined leaves. Flowers regular, hermaphroditic, each with five sepals, five hypogynous petals, ten stamens and a two- to three-celled ovary subtend-

ing three styles, each with a capitate stigma. Fruit an ovoid, angular, one celled drupe containing a single seed.

| Official drug     | Part used | Botanical origin                       | Habitat          |
|-------------------|-----------|--|------------------|
| Cocaina           | Alkaloid  | Erythroxyton Coca<br>and its varieties | Peru and Bolivia |
| <b>Unofficial</b> |           |  |                  |
| Coca              | Leaves    | Erythroxyton Coca<br>and its varieties | Peru and Bolivia |

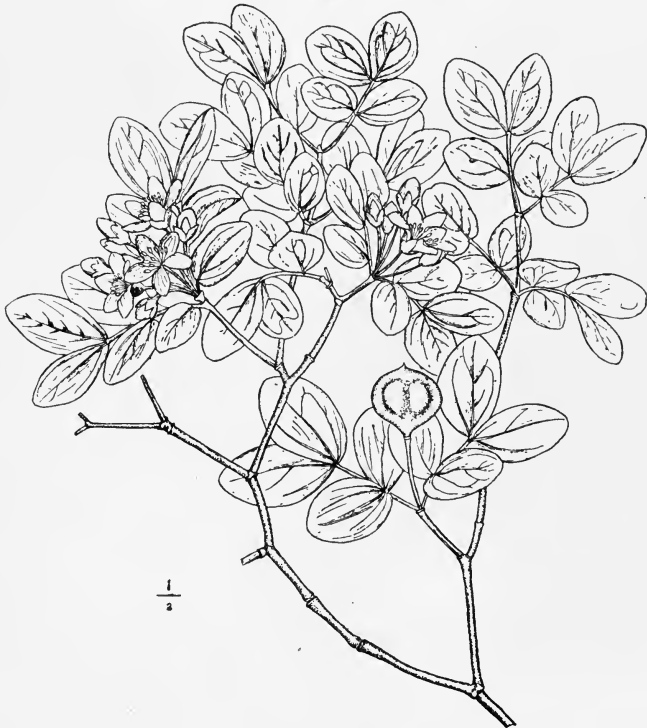

FIG. 205.—*Guaiacum sanctum*—Flowering branch. (Sayre.)

*Zygophyllaceæ* or *Caltrop* Family.—Herbs, shrubs or trees (*Guaia-cum*) having jointed, often divaricate branches. Leaves usually opposite, stipulate and compound. Flowers regular or irregular,

pentamerous, white, yellow, red or blue (*G. officinale*). Fruit a capsule.

| Official drug           | Part used     | Botanical origin  | Habitat                                 |
|-------------------------|---------------|---|---|
| Guaiacum                | Resin of wood | { <i>Guaiacum officinale</i><br><i>Guaiacum sanctum</i> | { Tropical and sub-<br>tropical America |
| Guaiaci Lignum<br>N. F. | Heartwood     | <i>G. officinale</i> and <i>G. sanctum</i>              | Tropical and sub-<br>tropical America   |



FIG. 206.—*Citrus Aurantium*—Branch. (Sayre.)

*Rutaceæ* or *Rue Family*.—Herbs (*Ruta*, *Diosma*, *Barosma*) or shrubs (*Xanthoxylum*) or trees (*Citrus*). Stems upright, often wiry xerophytic, in sub-family *Ruteæ*, elongated and spiny in sub-family *Zanthoxyleæ*, woody and green in sub-family—*Aurantieæ*. Leaves alternate or opposite, simple (*Ruta*), rarely whorled (*Pilocarpus*) or

pinnatifid, as in *Ruta graveolens*, or pinnate, as lower parts of *Ruta graveolens*, becoming reduced pinnate in *Citrus Aurantium*. Leaves exstipulate or with spiny stipules (*Xanthoxylum*). Stems and leaves abound in more or less sunken glands. Flowers pentamerous, varying in color from yellow in *Ruta* to white in *Citrus* to pink (*Barosma betulina*) or pink crimson as in some *Barosma* and *Diosma* species, rarely to pinkish-purple (*Pilocarpus*); sepals five, aposepalous becoming in *Citrus* more or less synsepalous; petals five, apopetalous becoming more or less synpetalous and tubular (*Correa grandiflora*); stamens five, simple or with expanded bases, lobed, or lobes developed as staminal stipules and more or less split (*Citrus*); pistil of ten, five, three or two carpels, ovary as many-celled. Fruit a capsule (*Dittany*, *Xanthoxylum*), berry (*Citrus*) or rarely a samara (*Ptelea*). Seeds albuminous or exalbuminous. Many of the plants contain volatile oils in their secretory cavities.



FIG. 207.—*Barosma betulina*—  
Branch and flower. (Sayre.)

| Official drug             | Part used                   | Botanical origin                                       | Habitat        |
|---------------------------|-----------------------------|--|----------------|
| Aurantii Dulcis<br>Cortex | Outer rind of<br>ripe fruit | Citrus Aurantium<br>sinensis                           | Sub-tropics    |
| Aurantii Amari<br>Cortex  | Rind of fruit               | Citrus Aurantium<br>amara                              | Northern India |
| Limonis Cortex            | Outer rind of<br>ripe fruit | Citrus medica<br>Limonum                               | Northern India |
| Pilocarpus                | Leaflets                    | { Pilocarpus Jaborandi<br>Pilocarpus<br>microphyllus } | Brazil         |
| Buchu                     | Leaves                      | { Barosma betulina<br>and B.serratifolia }             | Cape Colony    |

| Official drug              | Part used    | Botanical origin           | Habitat                |
|----------------------------|--------------|----------------------------|------------------------|
| Xanthoxylum                | Bark         | Xanthoxylum americanum     | Northern United States |
|                            |              | Xanthoxylum Clava-Herculis | Southern United States |
| Oleum Bergamottæ N.F.      | Volatile oil | Citrus Aurantium Bergamia  | France, Italy          |
| Oleum Aurantii Florum N.F. | Volatile oil | Citrus Aurantium amara     | Northern India         |
| Succus Citri N.F.          | Juice        | Citrus medica acida        | Asia                   |
| Xanthoxyli Fructus N.F.    | } Capsules   | Xanthoxylum americanum     | Northern United States |
|                            |              | Xanthoxylum Clava-Herculis | Southern United States |
| <b>Unofficial</b>          |              |                            |                        |
| Ruta                       | Leaves       | Ruta graveolens            | Southern Europe        |
| Ptelea                     | Bark of root | Ptelea trifoliata          | North America          |
| Belæ Fructus               | Unripe fruit | Ægle Marmelos              | Malabar, Coromandel    |

*Simarubaceæ* or *Ailanthus* Family.—A family of chiefly tropical shrubs or trees containing bitter principles. The leaves are alternate and pinnate. The flowers are dicæious or polygamous and arranged in axillary panicles (*Picrasma excelsa*) or racemes (*Quassia amara*). The plants are distinguished from those of the *Rutaceæ* by the absence of secretory cavities.

| Official drug     | Part used    | Botanical origin     | Habitat                              |
|-------------------|--------------|----------------------|--------------------------------------|
| Quassia           | Wood         | Picrasma excelsa     | West Indies                          |
|                   |              | Quassia amara        | Surinam                              |
| <b>Unofficial</b> |              |                      |                                      |
| Simaruba          | Bark of root | Simaruba officinalis | South America                        |
|                   |              | Simaruba amara       | Central America, Bahamas and Florida |

*Burseraceæ* or *Myrrh* Family.—Shrubs and trees of tropical climes having secretion reservoirs in their bark. Leaves alternate and compound. Flowers small, regular and hermaphrodite, arranged in racemes or panicles. Fruit a drupe.

| Official drug                 | Part used | Botanical origin          | Habitat                |
|-------------------------------|-----------|---------------------------|------------------------|
| Myrrha                        | Gum resin | <i>Commiphora</i> species | East Africa and Arabia |
| <b>Unofficial</b><br>Olibanum | Gum resin | <i>Boswellia carterii</i> | East Africa and Arabia |



FIG. 208.—*Picrosma excelsa*—Branch. (Sayre.)

*Meliaceæ* or *Mahogany Family*.—Tropical trees or shrubs with wood often hard, colored and odoriferous. Leaves alternate, ex-

stipulate, pinnately compound, rarely simple and entire. Inflorescence a terminal or axillary raceme. Flowers hermaphrodite or rarely polygamo-diœcious, regular; sepals five to four, small; petals usually five to four, hypogynous; stamens generally ten to eight



 $\frac{1}{2}$ 

FIG. 209.—*Commiphora myrrha*—Branch. (Sayre.)

rarely five, very rarely twenty to sixteen, inserted outside the base of the hypogynous disc; filaments united into a tube; carpels usually five to three; style simple; ovary free, usually five-to three-celled. Fruit a drupe (*Melia*), berry (*Vavaca*), or capsule (*Cedrella*). Seeds exalbuminous or with fleshy albumen.

| Official drug  | Part used | Botanical origin | Habitat |
|----------------|-----------|------------------|---------|
| Cocillana N.F. | Bark      | Guarea Rusbyi    | Bolivia |

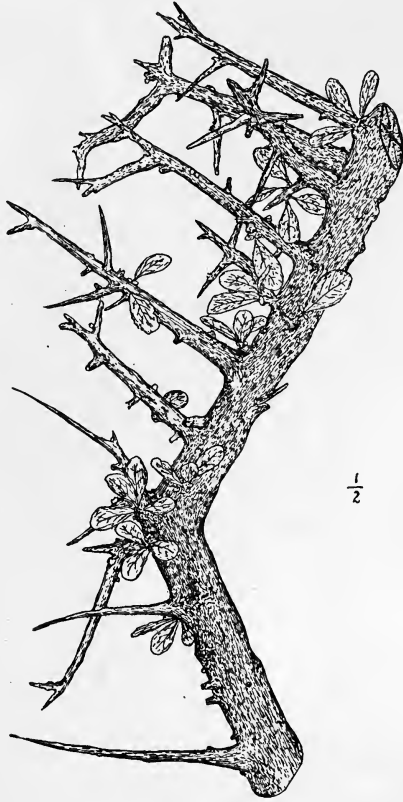
*Polygalaceæ* or *Milkwort Family*.—Herbs or shrubs with upright, herbaceous to woody stems often branching profusely, the branches



FIG. 210.—*Polygala senega*—Plant and rhizome (Sayre.)

occasionally becoming geotropic or subterranean and bearing cleistogamous flowers. Leaves simple, often lanceolate or linear, exstipulate, alternate. Inflorescence a raceme, spike (*Polygala*



*Senega*) or head (*P. lutea*). Flowers irregular, hermaphroditic with commonly eight stamens. Fruit a two-celled capsule (*P. Senega*), rarely a drupe or samara. Pollen grains barrel-shaped.

| Official drug | Part used | Botanical origin | Habitat                  |
|---------------|-----------|------------------|--------------------------|
| Senega        | Root      | Polygala Senega  | United States and Canada |

*Euphorbiaceæ* or *Spurge Family*.—Often herbaceous, more rarely shrubby, rather seldom arborescent plants. Stem, leaves and other parts in several genera traversed by latex canals that are either ramifying cells (*Euphorbias*) or laticiferous vessels (*Manihot*, *Hevea*, etc.) or rows of laticiferous sacs (*Micrandra*) and contain a white latex with acrid often poisonous contents or alkaloid or hydrocarbon, at times, rubber contents. Leaves alternate, exstipulate to stipulate, simple to pinnate or palmate. Inflorescence cymose. Flowers usually as in *Ricinus*, etc, pentamerous, diclinous; sepals five, green, aposepalous, becoming rudimentary or absent in *Anthostema* and *Euphorbia*. Petals none or five more or less petaloid; stamens numerous to ten to five or one (*Euphorbia*); pistil in pistillate flowers rarely of twenty to ten apocarpous or loosely syncarpous carpels (Sandbox tree), commonly of three syncarpous carpels with distinct radiate styles; ovary as many-celled as carpels with two to one ovules in each cell. Fruit a tricocoid regma or capsule, rarely winged, indehiscent, nut-like. Seeds with oily endosperm. Flowers at times surrounded and subtended by more or less petaloid and expanded bracts and bracteoles.

| Official name                | Part used        | Botanical origin                        | Habitat                |
|------------------------------|------------------|---|------------------------|
| Euphorbia<br>Pilulifera N.F. | Herb             | Euphorbia pilulifera                    | Tropics and subtropics |
| Stillingia                   | Root             | Stillingia sylvatica                    | Southern United States |
| Oleum Ricini                 | Volatile oil     | Ricinus communis                        | Asia and Africa        |
| Oleum Tiglii                 | Volatile oil     | Croton tiglium                          | Asia                   |
| Cascarilla N.F.              | Bark             | Croton Eluteria                         | West Indies            |
| <b>Unofficial</b>            |                  |   |                        |
| Tapioca                      | Starch           | Manihot utilissima                      | South America          |
| Kamala                       | Hairs of capsule | Mallotus<br>philippinensis              | Asia                   |
| Elastica                     | Prepared latex   | Hevea brasiliensis<br>and other species | Brazil                 |

**XVI. Order Sapindales.**—*Anacardiaceæ* or *Sumac Family*.—

Shrubs or trees producing in stems and leaves secretion contents that are either acrid watery or acrid opalescent or white viscid, viscid acrid and poisonous. Leaves alternate, rarely opposite, simple (*Rhus Cotinus*), three-foliolate (*Rhus toxicodendron*) or pinnate (*Rhus glabra*, *R. venenata*, etc.). Inflorescence frequently terminal and composed of racemes or cymes, often reduced to a simple raceme. Flowers small, clustered, green, greenish-white to greenish-yellow; sepals five, rarely six or four green, small; petals five smaller than sepals; stamens equal in number to the petals and alternate, rarely fewer, sometimes double in number, rarely indefinite, inserted hypogynously or upon an enlarged disc that surrounds or swells up between stamens and pistil; pistil monocarpellary more rarely bicarpellary, very rarely as in *Spondiææ* of ten to five carpels, ovary one-celled with single ovule. Fruit a drupe. Seeds exalbuminous with large embryo filling seed cavity.

| Official drug      | Part used                 | Botanical origin       | Habitat                  |
|--------------------|---------------------------|------------------------|--------------------------|
| Rhus Glabra N.F.   | Ripe fruits               | Rhus glabra            | Canada and United States |
| Mastiche N.F.      | Concrete resinous exudate | Pistacia Lentiscus     | Grecian Archipelago      |
| <b>Unofficial</b>  |                           |                        |                          |
| Chinese Galls      | Excrescences              | Rhus semialata         | China                    |
| Japanese Galls     | Excrescences              | Rhus japonica          | Japan                    |
| Rhus Typhina       | Ripe fruits               | Rhus typhina           | United States            |
| Acajou Gum         | Gum                       | Anacardium occidentale | West Indies              |
| Pistachio          | Seeds                     | Pistacia vera          | Western Asia             |
| Anacardium         | Fruit                     | Anacardium occidentale | West Indies              |
| Rhus Toxicodendron | Fresh leaflets            | Rhus toxicodendron     | United States            |

*Celastraceæ* or *Staff Tree Family*.—Shrubs (*Euonymus*), or shrubby climbers (*Celastrus*). Leaves alternate, rarely opposite, simple, entire or toothed. Inflorescence of axillary cymes or terminal racemes. Flowers perfect (*Euonymus*, *Pachistima*) or polygamo-dicæcious (*Celastrus*) greenish (*Celastrus*), greenish or yellowish-white (*Euonymus Europæus*), greenish-purple (*Euonymus americanus*) to dark-

purple (*Euonymus atropurpureus*); calyx four to five-lobed; corolla of four to five petals; stamens four to five, perigynous, inserted on a disc, which fills the base of the calyx and sometimes covers the ovary; ovary three- to five-celled. Fruit a two-to five-celled capsule. Seeds albuminous with fleshy succulent reddish aril (*Euonymus*, *Celastrus*) or white membranous aril (*Pachistima*).

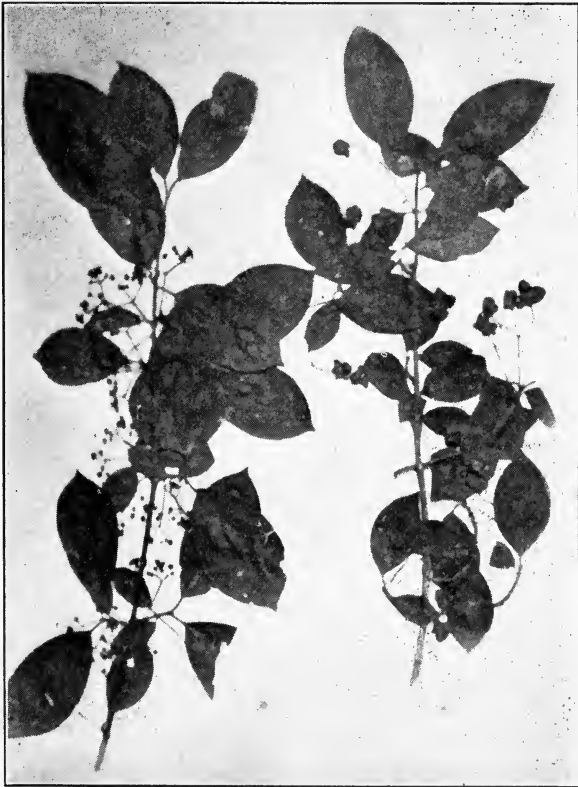

FIG. 211.—*Euonymus atropurpureus*. Flowering branch to left; fruiting branch to right.

| Official drug | Part used    | Botanical origin              | Habitat       |
|---------------|--------------|-------------------------------|---------------|
| Euonymus N.F. | Bark of root | <i>Euonymus atropurpureus</i> | United States |

*Sapindaceæ* or *Soapwort Family*.—Trees, shrubs, undershrubs or rarely herbs of tropical climes containing the glucoside saponin. Stem erect or climbing (*Paullinia*) often provided with tendrils. Leaves commonly alternate and compound. Flowers in racemes or panicles (*Paullinia*), perfect or polygamo-diœcious, yellowish in

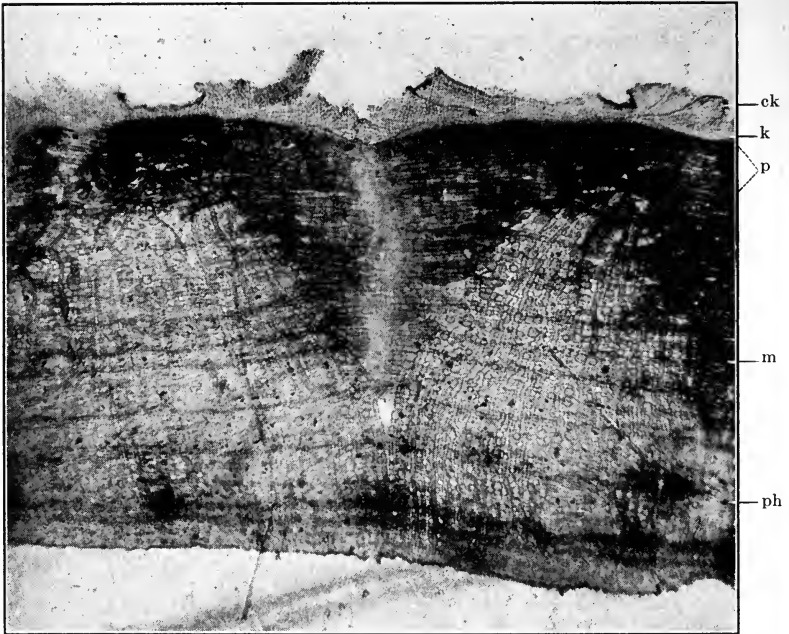

FIG. 212.—Cross section through root-bark of *Euonymus atropurpureus*. Note the two broad dome-shaped phloem patches, one on either side of a wedge-shaped primary medullary ray.

*Paullinia Cupana*. Fruit a capsule (*P. Cupana*), samara, drupe or berry. Seeds exalbuminous.

| Official drug | Part used                                   | Botanical origin        | Habitat |
|---------------|---|-------------------------|---------|
| Guarana       | Dried Paste,<br>chiefly of<br>crushed seeds | <i>Paullinia Cupana</i> | Brazil  |

*Aceraceæ* or *Maple Family*.—Chiefly trees, occasionally shrubs, of temperate regions with watery sap. Leaves opposite, simple and

palmately lobed, cleft (*Acer*) or pinnate (*Negundo*). Inflorescence a raceme condensing in some species to a capitulum of cymes. Flowers small, regular, polygamous or diœcious; sepals five to four green; petals none or five, variously colored; stamens usually eight, hypogynous or perigynous; nectar disc around stamens or between them and pistil; pistil bicarpellary with two-celled ovary. Fruit a samara. Seeds green, exalbuminous with coiled or folded embryo and long thin cotyledons.

| Unofficial drug | Part used | Botanical origin | Habitat       |
|-----------------|-----------|------------------|---------------|
| Acer Spicatum   | Bark      | Acer spicatum    | United States |

**XVII. Order Rhamnales.**—*Rhamnaceæ* or *Buckthorn Family*.—Shrubs or low trees usually of branching or spreading habit. Branches either cylindrical or long green or hardened, checked back and spinescent, occasionally, especially flowering branches developing tendrils for support. Leaves simple, usually alternate. Flowers hermaphrodite or more or less diclinous, pentamerous to tetramerous, greenish to greenish-yellow to yellowish-white; sepals five to four; petals five to four alternating with sepals; stamens five opposite the petals, perigynous; pistil either free in center of receptacular cup or more or less fused with it and so semi-inferior, ovary typically three-celled becoming rarely four-celled with two to one atropous ovules in each cavity. Fruit of three indehiscent cocci, each enclosing a single albuminous seed with straight embryo imbedded in albumen.

| Official drug              | Parts used | Botanical origin   | Habitat   |
|----------------------------|------------|--------------------|---|
| Cascara Sagrada            | Bark       | Rhamnus Purshiana  | Northern California to southwestern British America |
| Frangula                   | Bark       | Rhamnus Frangula   | Europe  |
| Rhamnus<br>Cathartica N.F. | Fruit      | Rhamnus cathartica | Asia and Africa                                     |

*Vitaceæ* or *Grape Family*.—Rarely tall herbaceous, usually shrubby and climbing, more rarely shrubby upright plants. Stems rarely short more usually elongate, feeble, rather brittle, climbing by tendrils which represent modified inflorescence shoots. Leaves

alternate, simple to lobed (either pinnately or more often palmately) to compound-pinnate or palmate. Perfect graded series of lanceolate leaves with pinnate veining to palmate veining; from pinnately veined to compound-pinnate; from palmately veined to compound-



FIG. 213.—*Rhamnus frangula*—Branch. (Sayre.)

palmate. Stipules greenish to membranous or none. Flowers in racemes of compressed cymes, hermaphrodite or diclinous, nearly always small, clustered, green to greenish-yellow or greenish-white, rarely otherwise; sepals five, rarely four, small to minute (mere rim of receptacle) more or less persistent. Petals five, deciduous to

caducous, typically distinct, in *Vitis* united by their tips into calypetroform corolla, so in June, as Grape Vine flowers expand, corolla splits at base into five lobes that separate below, being attached at tips, while whole becomes tumbled off by lengthening stamens. Pistil bicarpellate. Ovary two-celled, superior at or most sub-inferior. Ovules two to one, erect. Style short often more or less thickened with terminal, capitate, slightly two-lobed stigmas. Stamens equal to petals or sepals and opposite petals. Receptacle internal to stamens, often expanded into nectariferous girdle or, in *Vitis*, into receptacular knobs alternating with stamens. Fruit a berry rarely six- to three-celled, typically two-celled and with two to one seeds in each cavity. Seeds like ovules, erect, with bony testa. Embryo small, imbedded at base of cartilaginous albumen.

| Official drug         | Part used                        | Botanical origin              | Habitat    |
|-----------------------|----------------------------------|-------------------------------|------------|
| Vinum Xericum<br>N.F. | Fermented juice<br>of ripe fruit | Vitis species<br>(cultivated) | Cultivated |

**XVIII. Order Malvales.**—*Sterculiaceæ* or *Cola Family*.—Rarely herbs, usually shrubs or tall, often heavy trees with soft wood and broad annual rings. The cambium, in developing bast, produces one, two, three, four, or five alternating layers of hard and soft bast which in some species of this as well as the *Tiliaceæ* family form long finger-like processes pushing out into the cortex. Leaves alternate, sometimes simple and pinnately veined or passing to palmately veined or palmately compound. Flowers hermaphrodite; sepals five, sometimes surrounded by bracteoles forming an epicalyx; petals usually five; stamens typically five hypogynous, opposite petals, distinct or slightly fused in monadelphous fashion (*Melochia*, *Waltheria*) or, stamens subdivided above into few or numerous staminal leaflets, anthers two-celled; pistil many to ten- to five- or four-carpelled; carpels apocarpous or more usually partially or completely united. Fruit either follicles, or fused to form a capsule of ten or more, frequently five dehiscent carpels or, carpels splitting asunder into cocci or, becoming a woody capsular nut (*Theobroma*) or, rarely the fruit may become succulent. Seeds globose or subglobose and often provided with wings, arils or similar appendages; embryo straight, large and surrounded by scanty albumen.

| Official drug         | Part used | Botanical origin | Habitat          |
|-----------------------|-----------|------------------|------------------|
| Oleum<br>Theobromatis | Fixed oil | Theobroma Cacao  | Tropical America |



FIG. 214.—*Theobroma cacao*—Branch and fruit. (Sayre.)

|                       |   |  |                     |
|-----------------------|---|--|---------------------|
| Cacao Præparatum N.F. | Prepared powder from roasted kernels of seeds | <i>Theobroma Cacao</i> and other species | Tropical America    |
| Kola N.F.             | Cotyledons                                    | <i>Cola acuminata</i> and other species  | Africa, West Indies |



*Tiliaceæ* or *Linden Family*.—Shrubs or trees, rarely herbs, having stellate hairs on both stems and leaves. Leaves alternate, pinnately more rarely palmately veined, stipulate. Inflorescence cymose. Flowers hermaphrodite, more rarely, by absorption, more or less diclinous; sepals and petals five each, more rarely four, sepals deciduous; stamens five opposite the petals or, as in *Sterculiaceæ*, five phalanges of stamens representing subdivided stamens (*Tilia*), pistil of ten to five or two syncarpous carpels; ovary superior. Fruit either a nut-like drupe or drupe, rarely baccate.

| Unofficial drug | Part used     | Botanical origin | Habitat                  |
|-----------------|---------------|------------------|--------------------------|
| Tilia           | Inflorescence | Tilia species    | United States and Europe |

*Malvaceæ* or *Mallow Family*.—Herbs in temperate regions (*Malva rotundifolia*, *Althæa officinalis*, etc.), occasionally shrubs in temperate regions (*Hibiscus Syriacus*, etc.), frequently shrubs or tall trees in the tropics. Stems, as in *Sterculiaceæ* and *Tiliaceæ*, sometimes forming numerous layers of hard and soft bast. Leaves alternate and stipulate, ovate, ovate-cordate, orbicular or palmately compound; venation pinnate or palmate. Stems, roots and leaves contain mucilage cells. Inflorescence a raceme or fascicle of cymes. Flowers regular, pentamerous; calyx green, of five aposepalous sepals but frequently surrounded outside by an epicalyx. Both calyx and epicalyx are persistent. Corolla of five petals varying in color which are more or less fused with stamens at their bases; stamens monadelphous and forming an upright column enclosing the styles; anthers one-celled, dehiscing transversely; pollen grains echinate; pistil loosely or strongly syncarpous, rarely sub-apocarpous of thirty to five carpels. Fruit either a set of cocci, follicles or a capsule (*Gossypium*). Seeds albuminous with oily and mucilaginous albumen.



FIG. 215.—*Gossypium herbaceum*—Branch. (Sayre.)

| Official drug                 | Part used            | Botanical origin                                   | Habitat                                       |
|-------------------------------|----------------------|--|---|
| <i>Althæa</i>                 | Root (peeled)        | <i>Althæa officinalis</i>                          | Europe and Asia                               |
| <i>Althæa Folia</i> N.F.      | Leaves               | <i>Althæa officinalis</i>                          | Europe and Asia                               |
|                               |                      | Cultivated varieties of:                           |   |
|                               |                      | <i>Gossypium herbaceum</i>                         | Arabia, United States, East Indies            |
| <i>Gossypii Cortex</i> N.F.   | Bark of root         | <i>Gossypium Barbadense</i>                        | United States and Africa                      |
|                               |                      | <i>Gossypium arboreum</i>                          | Egypt, Arabia and India                       |
| <i>Gossypium Purificatum</i>  | Hairs of seed        | Cultivated varieties of <i>Gossypium herbaceum</i> | Arabia, East Indies, United States            |
| <i>Oleum Gossypii Seminis</i> | Fixed oil from seeds | Cultivated varieties of <i>Gossypium</i> species   | United States, Asia, Africa and South America |
| <i>Malva Folia</i> N. F.      | Leaves               | <i>Malva sylvestris</i>                            | Europe  |
|                               |                      | <i>Malva rotundifolia</i>                          |   |
| <b>Unofficial</b>             |                      |  |   |
| <i>Althæa Flores</i>          | Flowers              | <i>Althæa rosea</i>                                | Europe  |

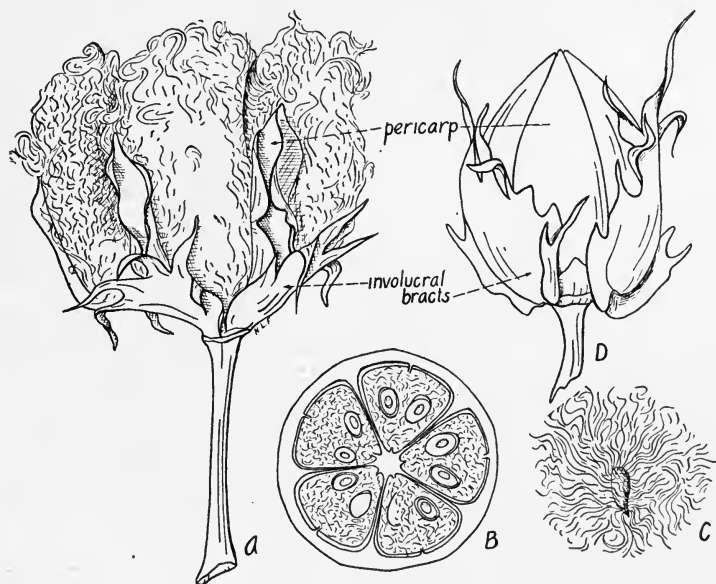

FIG. 216.—Upland cotton (*Gossypium hirsutum*). A, mature boll opened out; B, cross-section of young boll; C, single seed with fibers; D, young boll. (Robbins.)

**XIX. Order Parietales** (Ovaries of flower have parietal placentas.)—*Theaceæ* or *Tea Family* (*Ternstræmiaceæ*, *Cammeliaceæ*).—Evergreen shrubs or low branching or tall, often heavy trees with watery juice. Leaves for the most part alternate, evergreen, often leathery, sometimes membranous; stipules either bud scales and caducous or often absent; leaf margins sinuate or serrate (*Thea*). Inflorescence a raceme becoming by condensation terminal, one-flowered. Flowers regular, perfect, pentamerous; sepals five, rarely four to three, deciduous, occasionally subtended by bracteolar scales; petals five, brittle and succulent varying from greenish-white or greenish-yellow through yellow to white or, from whitish pink to pink, scarlet, crimson, very rarely a tendency toward purple; stamens typically five but, as they grow, they subdivide into staminal leaflets, so that in their mature condition they are apparently indefinite and mono- to polyadelphous; stamens inserted hypogynously or perigynously and opposite the petals; pistil of typically five syncarpous carpels but reduced in some species to four to three or two. Fruit usually a capsule (*Thea*), five- to three-celled, dehiscent longitudinally, more rarely a fleshy, semi-baccate, semi-drupaceous indehiscent fruit. Seeds with scanty or no albumen and often attached to inner angle of cells by projecting spongy placenta.

| Official drug     | Part used              | Botanical origin  | Habitat      |
|-------------------|------------------------|---|--------------|
| Caffeina          | Feebly basic substance | <i>Thea sinensis</i>                                      | Eastern Asia |
| <b>Unofficial</b> |                        |   |              |
| <i>Thea</i>       | Leaves                 | <i>Thea sinensis</i> var. <i>Bohea</i> and <i>viridis</i> | Eastern Asia |

*Guttiferæ* or *Gamboge Family*.—Tropical trees (*Garcinia*), rarely shrubs, containing resinous principles in resin canals found in cortex and pith. Leaves opposite, coriaceous. Flowers diœcious, generally pentamerous or tetramerous with usually five stamens which are subdivided. Fruit a berry (*Garcinia Hanburyi*), drupe or capsule. Seeds generally large; embryo large to huge, often with enlarged radicle and reduced or absorbed cotyledons.

| Official drug | Part used | Botanical origin         | Habitat                           |
|---------------|-----------|--------------------------|-----------------------------------|
| Cambogia      | Gum resin | <i>Garcinia Hanburyi</i> | { Malabar coast<br>and Travancore |

*Hypericaceæ* or *St. John's Wort Family*.—Herbs or shrubs of temperate climes with opposite (*Hypericum perforatum*) rarely whorled branches and balsamic, resinous juices, which, in the herbaceous species, are secreted by black or pellucid glands found in the

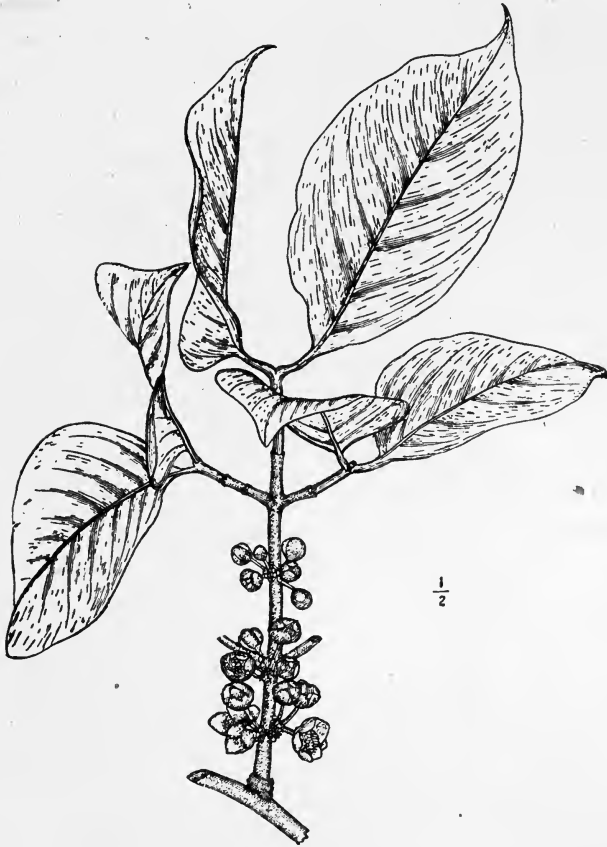

FIG. 217.—*Garcinia hanburii*—Branch. (Sayre.)

leaf parenchyma. Leaves entire, opposite, usually sessile, exstipulate, and dotted. Flowers, regular, hypogynous and arranged in panicles or forked cymes. Petals usually 5. Stamens usually indefinite, rarely definite, often in 3-5 sets, more rarely monadelphous

or free. Pistil of usually 3-5 carpels with 3-5 celled compound ovary and as many filiform styles as carpels. Fruit a capsule with usually septicial dehiscence (*Hypericum*) or a berry. Seeds small, numerous, anatropous and exalbuminous.

| Unofficial drug  | Part used    | Botanical origin            | Habitat |
|------------------|--------------|-----------------------------|---------|
| <i>Hypericum</i> | Entire plant | <i>Hypericum perforatum</i> | Europe  |

*Canellaceæ Family*.—Trees the bark of which contains aromatic principles. Leaves alternate, pellucid-punctate. Flowers regular, golden-yellow, and arranged in terminal or axillary cymes. Fruit a berry containing two to many seeds with oily and fleshy albumen.

| Official drug | Part used  | Botanical origin         | Habitat                      |
|---------------|------------|--------------------------|------------------------------|
| Canella N.F.  | Inner bark | <i>Canella Winterana</i> | { Florida and West<br>Indies |

*Bixaceæ Family*.—Tropical shrubs or trees. Leaves alternate, simple with minute or no stipules. Flowers hermaphrodite or unisexual, regular, stamens hypogynous, mostly indefinite with anthers opening by slits, rarely by one or two apical pores (*Bixa*). Fruit fleshy or dry. Seeds with fleshy albumen and sometimes covered with a fleshy arillus (*Bixa Orellana*).

| Unofficial drug | Part used            | Botanical origin          | Habitat                              |
|-----------------|----------------------|---------------------------|--------------------------------------|
| Annatto         | Coloring matter      | <i>Bixa Orellana</i>      | { Tropical America<br>and Madagascar |
| Chaulmoogra oil | Fixed oil from seeds | <i>Gynocardia odorata</i> | India                                |

*Violaceæ or Violet Family*.—Herbs or shrub. Stems upright, rarely creeping, spreading or acaulescent. Leaves either cauline or radical, stipulate, alternate, simple to pinnatifid or palmate. Flowers pentamerous, regular or irregular (*Viola*). Fruit a loculicidally dehiscent capsule (*Viola*) rarely baccate. Seeds albuminous.

| Unofficial drug | Part used   | Botanical origin      | Habitat           |
|-----------------|-------------|-----------------------|-------------------|
| <i>Viola</i>    | Entire herb | <i>Viola tricolor</i> | Temperate regions |

*Turneraceæ or Damiana Family*.—Tropical herbs, shrubs or trees. Leaves alternate, simple, petioled, exstipulate. Flowers perfect, regular, axillary, pentamerous with one-celled ovary. Fruit

a capsule with three valves. Seeds strophiolate with albuminous embryo.

| Official drug | Part used | Botanical origin                             | Habitat                          |
|---------------|-----------|--|----------------------------------|
| Damiana N.F.  | Leaves    | { Turnera diffusa<br>Turnera<br>aphrodisiaca | { Lower California<br>and Mexico |

*Passifloraceæ* or *Passion Flower Family*.—Herbaceous or woody vines climbing by tendrils. Leaves alternate, simple, entire, lobed or compound. Flowers perfect or imperfect, solitary; peduncles jointed at the flower; perianth petaloid with urceolate or tubular tube and four to five or eight to ten partite and two-seriate limb, the throat usually crowned by one or more series of subulate filaments which are frequently colored; gynophore elongating supporting the stamens and pistil. Fruit a one-celled berry (*Passiflora*) or three- to five-valved dehiscent capsule containing numerous seeds.

| Official drug   | Part used   | Botanical origin     | Habitat       |
|-----------------|-------------|----------------------|---------------|
| Passiflora N.F. | Entire herb | Passiflora incarnata | United States |

*Caricaceæ* or *Papaw Family*.—A family of latex-containing trees composed of two genera indigenous to tropical America. Of chief pharmaceutic interest is the species *Carica Papaya*, the Papaw or Melon tree, the fruit of which yields Papain, a valuable digestive ferment. This plant is a tree about 20 feet high which bears at its summit a cluster of deeply lobed petiolate leaves and diœcious flowers. The fruit is a berry, the size of one's head and contains an acrid milky juice from which papain can be precipitated by the addition of alcohol.

*Cistaceæ* or *Rock Rose Family*.—Herbs or shrubs whose stem and branches are often glandular, pubescent or tomentose, with simple or stellate trichomes. Leaves simple, entire, the lower ones opposite, upper alternate. Flowers perfect, regular, terminal, and solitary or in cymes or unilateral racemes; sepals five, the two external ones often bractiform or wanting; petals five (*Helianthemum*) rarely three or none (*Lechea*); stamens hypogynous, indefinite; carpels three to five, ovary free, one-celled. Fruit a one-celled, three- to five-valved capsule.

| Official drug        | Part used | Botanical origin          | Habitat                  |
|----------------------|-----------|---------------------------|--------------------------|
| Helianthemum<br>N.F. | Herb      | Helianthemum<br>canadense | Eastern United<br>States |

XX. Order Opuntiales.—*Cactaceæ* or *Cactus* Family.—Herbaceous rarely arborescent (*Cereus giganteus*) more or less succulent

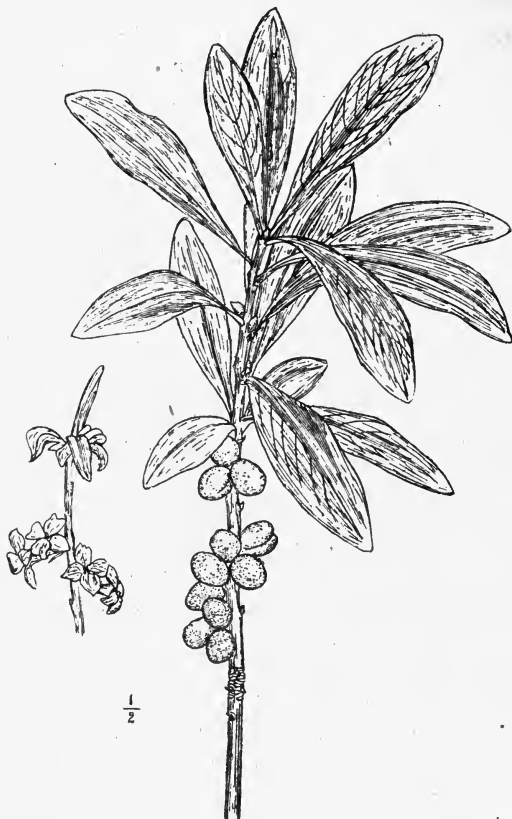

FIG. 218.—*Daphne mezereum*—Fruiting branch and flowers. (Sayre.)

plants living in warm, dry (*Peireskia*), usually desert situations, rarely becoming epiphytic and correspondingly modified. Stems accordingly varying from elongate, slightly enlarged, green (*Peireskia*) to flattened (*Cereus* and *Opuntia*), to condensed (*Echinocactus*,



*Echinocereus*, etc.), to greatly condensed (*Mamillaria*). Leaves alternate, stipulate or exstipulate, enlarged and more or less fleshy (*Peireskia*), becoming reduced, green and semicircular (*Opuntia*), or modified into spines, or wholly absorbed. Flowers, regular, solitary or fascicled in axils of leaves; sepals five; petals similar to sepals, petaloid, small to much enlarged, in color varying from yellow to white or from yellow to yellowish-pink, pink, scarlet or crimson; stamens indefinite, inserted at varying levels in the throat of a greatly expanded upgrown receptacle; pistil generally tricarpellary; ovary inferior, often deeply sunk in upgrown receptacular part; style thread-like, divided above into as many stigmas as carpels. Fruit a receptacular berry enclosing numerous small seeds. Seeds exalbuminous.

| Official drug | Part used       | Botanical origin               | Habitat            |
|---------------|-----------------|--------------------------------|--------------------|
| Cactus        | Fresh succulent | Cactus grandiflorus            | } Tropical America |
| Grandiflorus  | stems           | ( <i>Cereus grandiflorus</i> ) |                    |
| N.F.          |                 |                                |                    |

**XXI. Order Myrtales (Myrtifloræ).**—*Thymeleaceæ* or *Mezereum Family*.—Shrubs (*Daphne Mezereum*) or low trees, usually of branching habit, the stems developing long tenacious bast fibers. Leaves alternate, rarely opposite, coriaceous, simple, varying from lanceolate to ovate. Inflorescence a condensed raceme or spike. Flowers perfect, polygamous or diœcious, small with calyx alone of the perianth parts developed. This is crimson-purple in *Daphne Mezereum*. Sepals usually fused to form a tube or cup-shaped perianth. Stamens usually eight in two rows of four longer and four shorter (*Daphne Mezereum*) inserted on the calyx tube. Pistil monocarpellary; ovary superior mostly one-celled with a single pendulous ovule. Fruit a nut, drupe, or berry (*Daphne*).

| Official drug | Part used | Botanical origin  | Habitat           |
|---------------|-----------|---|-------------------|
| Mezereum      | Bark      | {<br>Daphne Mezereum<br>Daphne Gnidium<br>Daphne Laureola | } Europe and Asia |

*Punicaceæ* (*Lythraceæ*) or *Pomegranate Family*.—Herbs (*Cuphea*), shrubs (*Decadon*) or low trees (*Punica*). Leaves either alternate, opposite (*Punica*) or whorled, simple, usually lanceolate to ovate, entire, often glandular and viscous. Inflorescence a raceme, spike,

or condensed cyme. Flowers perfect, usually regular, but pass more or less to irregular, sometimes very irregular as in genus *Cuphea*; sepals five to four, more or less fused below in themselves and with calyx tube; petals commonly five, often frilled or crumpled, inserted on the mouth of the calyx tube; stamens fifteen, ten or five in alternate rows of five each, inserted hypogynously or perigynously; pistil six-, five-, four-, two-, rarely one-carpeled with as many cavities in the ovary and numerous small ovules; style elongate with pointed or knobbed stigma. Flowers of *Punica granatum* are scarlet in color. Fruit a baccate capsule (*Punica granatum*) or



FIG. 219.—*Punica granatum*—Branch with flowers. (Sayre.)

capsule, dehiscing longitudinally or transversely. Seeds exalbuminous.

| Official drug             | Part used     | Botanical origin        | Habitat       |
|---------------------------|---------------|-------------------------|---------------|
| Granatum                  | Bark          | <i>Punica Granatum</i>  | India         |
| <b>Unofficial</b>         |               |                         |               |
| Granati Fructus<br>Cortex | Rind of fruit | <i>Punica Granatum</i>  | India         |
| Henna                     | Leaves        | <i>Lawsonia inermis</i> | Egypt, Arabia |



FIG. 220.—*Eucalyptus globulus*—Branch. (Sayre.)

*Myrtaceæ* or *Myrtle Family*.—Rarely herbs (*Careya*) mostly shrubs or trees, some being the tallest trees known (*Eucalyptus*). Stems often tend to develop cork in flakes which separate much as in the Buttonwoods. Leaves rarely alternate nearly always oppo-



FIG. 221.—*Eugenia aromatica*. (Sayre.)

site, entire, often glistening, subcoriaceous to coriaceous (*Eucalyptus*, *Pimenta*, etc.), frequently edge-on in position upon branches. Inflorescence cymose, at times forming scorpioid cymes becoming condensed into small fascicles, or each cyme condensing into a solitary flower.

Flowers regular or very rarely irregular from the lop-sided development of the stamens. Symmetry rarely hexamerous, typically pentamerous, not infrequently reduced to tetramerous (*Clove*); sepals five, six or four, aposepalous, or synsepalous at base, superior, and inserted around the edge of an expanded, upgrown receptacular disc, varying from green and more or less expanded to short, thick fleshy (*Clove*) or reduced to teeth (*Eucalyptus*); petals equal in number to the sepals, more or less petaloid and enlarged, rarely reduced and wanting, varying in color from green through greenish-yellow to white (*Eugenia* species) or from whitish to pink, scarlet, crimson, purple and blue, petals sometimes synpetalous and cup-like, detaching as the flower opens; stamens usually indefinite and epigynous, varying in the color of their filaments as do the petals; pistil rarely of ten to six carpels usually of five, not infrequently, as in *Clove*, of four carpels; ovary inferior or semi-inferior, as many-celled as there are carpels and with central placentation; style elongate; stigma undivided. Fruit either a hard, woody indeshicent nut (*Brazil Nut*), a capsule dehiscing at apex (*Eucalyptus*) or berry (*Eugenia*). Seeds exalbuminous.

| Official drug     | Part used                          | Botanical origin                                | Habitat                                    |
|-------------------|------------------------------------|---|--|
| Eucalyptus        | Leaves                             | <i>Eucalyptus globulus</i>                      | Australia,                                 |
| Eucalyptol        | Organic oxide                      | <i>Eucalyptus globulus</i>                      | Tasmania                                   |
| Caryophyllus      | Flower buds                        | <i>Eugenia aromatica</i>                        | } Molucca Islands                          |
| Eugenol           | Aromatic phenol                    | <i>Eugenia aromatica</i>                        |  |
| Pimenta N.F.      | Fruit                              | <i>Pimenta officinalis</i>                      | West Indies;<br>Central America,<br>Mexico |
| Oleum Cajuputi    | Volatile oil from leaves and twigs | <i>Melaleuca</i><br><i>Leucadendron</i>         | East Indies                                |
| <b>Unofficial</b> |                                    |   |  |
| Myrcia            | Volatile oil and leaves            | <i>Myrcia acris</i>                             | West Indies                                |
| Eucalyptus Kino   | Inspissated juice                  | <i>Eucalyptus rostrata</i><br>and other species | Australia                                  |

*Combretaceæ* or *Myrobalans* Family.—Mostly tropical shrubs and trees containing considerable tannin. Leaves exstipulate, alternate or opposite, simple, pinnately veined, entire or toothed. Inflorescence a raceme, spike or head. Flowers regular, perfect

or imperfect. Fruit a drupe, frequently longitudinally winged, containing a single seed.

| Unofficial drug | Part used | Botanical origin       | Habitat |
|-----------------|-----------|------------------------|---------|
| Combretum       | Leaves    | Combretum<br>sundaicum | Sumatra |

**XXII. Order Umbellales or Umbellifloræ.**—*Araliaceæ* or *Ginseng Family*.—Herbs (*Panax quinquefolium*, *Hedera Helix*, *Aralia nudicaulis*, etc.), undershrubs (*Aralia hispida*, etc.), shrubs (*Fatsia horrida*), or trees (*Aralia spinosa*) with stems which are more or less hollow along internodes and solid at nodes. Leaves alternate, varying from simple to trifoliate or to multipinnate (tropical Aralias) or passing by telescoping into compound-palmate. Leaves serrate margined and along with stem they develop volatile oil, resin and gum contents in secretion reservoirs. Inflorescence varying from a raceme of umbels to a raceme and even to condensed racemose umbels. Flowers regular, generally pentamerous, small, generally inconspicuous, green, greenish-yellow to rarely white, usually hermaphrodite but sometimes polygamous or dioecious; sepals five, rarely four; petals five, rarely four, often greenish to greenish-yellow, occasionally white, seldom pink in color; stamens varying from indefinite to ten to commonly five, opposite sepals, and, like sepals, epigynous in insertion; anthers versatile; pistil occasionally fifteen- to ten-, usually five-carpellate; ovary as many celled with one or rarely two pendulous ovules in each cavity; styles distinct ending in knob-shaped stigmas. Fruit a berry. Seeds albuminous.

| Official drug     | Part used         | Botanical origin    | Habitat                          |
|-------------------|-------------------|---------------------|----------------------------------|
| Aralia N.F.       | Rhizome and roots | Aralia racemosa     | Eastern United States and Canada |
| <b>Unofficial</b> |                   |                     |                                  |
| Aralia Nudicaulis | Rhizome           | Aralia nudicaulis   | Eastern United States and Canada |
| Aralia Spinosa    | Bark              | Aralia spinosa      | Eastern United States            |
| Ginseng           | Root              | Panax quinquefolium | North America                    |
| Panax Repens      | Rhizome           | Panax repens        | Japan                            |

*Umbelliferae or Parsley Family.*—Herbs, rarely shrubs, often of rapid growth, and with upright, fistular (hollow at internodes, solid at nodes), often grooved and ridged stems. Leaves alternate, compound and usually much divided, exstipulate, but with expanded sheathing and flattened leaf base (Pericladium), that ensheathes the stem. Inflorescence a simple or often compound umbel surrounded by an involucre of bracts or of bracteoles. Flowers small, pentamerous, with inferior ovary and superior floral parts. Sepals minute, tooth-like, inserted above inferior ovary, or absorbed. Petals small, usually yellow to white, rarely pink to purple, distinct, each with inflexed tip. Stamens five, epigynous, inserted below a nectariferous, epigynous disc, incurved in bud. Carpels two, fused into bicarpellate pistil. Ovary two-celled, with one pendulous ovule in each cell, ovarian wall traversed by oleoresin canals; styles two, distinct above the nectar disc or stylopod. Fruit a dry, splitting fruit or cremocarp, that splits lengthwise into two mericarps which hang for a time by a forked carpophore. Seeds single in each mericarp, albuminous.

| Official drug          | Part used                                   | Botanical origin                          | Habitat                             |
|------------------------|---|---|-------------------------------------|
| Anisum                 | Ripe fruit                                  | Pimpinella Anisum                         | Asia Minor, Egypt and Greece        |
| Anethol N.F.           | { Methyl ether of<br>para-pro-phenyl phenol | { Pimpinella Anisum<br>Foeniculum vulgare |                                     |
| Foeniculum             |   |   | Nearly ripe fruit                   |
| Sumbul                 | Rhizome and roots                           | Ferula Sumbul                             | Turkestan                           |
| Carum                  | Fruit                                       | Carum Carvi                               | Europe, Asia                        |
| Conium N.F.            | Unripe fruit                                | Conium maculatum                          | Europe                              |
| Asafœtida              | Gum resin                                   | Ferula foetida, F. Asafœtida, etc.        | Persia and Afghanistan              |
| Coriandrum             | Ripe fruit                                  | Coriandrum sativum                        | Mediterranean and Caucasian regions |
| Petroselinum           | Ripe fruit                                  | Petroselinum sativum                      | Southern Europe<br>Asia Minor       |
| Petroselini Radix N.F. | Root  | Petroselinum sativum                      | Southern Europe,<br>Asia Minor      |
| Angelica Fructus       | Ripe fruit                                  | Angelica Archangel-                       | Northern Europe                     |

| Official drug       | Part used         | Botanical origin                                    | Habitat                  |
|---------------------|-------------------|---|--------------------------|
| N.F.                |                   | ica and other species of Angelica                   | and Siberia              |
| Angelicæ Radix N.F. | Rhizome and roots | Angelica atropurpurea and other species of Angelica | United States and Canada |
| Apii Fructus N.F.   | Ripe fruit        | Apium graveolens                                    | England                  |
| <b>Unofficial</b>   |                   |   |                          |
| Imperatoria         | Root              | Imperatoria Ostruthium                              | Europe                   |
| Pimpinella          | Roots             | { Pimpinella Saxifraga }<br>{ Pimpinella magna }    | Central Europe           |
| Ammoniacum          | Gum-resin         | Dorema Ammoniacum                                   | Persia                   |
| Galbanum            | Gum-resin         | Ferula galbaniflua                                  | Persia and Afghanistan   |
| Levisticum          | Root              | Levisticum officinale                               | Europe                   |

*Cornaceæ* or *Dogwood Family*.—Herbs (*Cornus canadensis*, etc.), shrubs (*Cornus sanguinea*, etc.) or trees (*Cornus florida*, *Nyssa sylvatica*, etc.). Leaves simple, alternate (Sour Gum), or opposite (Dogwoods). Inflorescence an umbel or head, the whole being surrounded by an enlarged and more or less petaloid involucre. Flowers regular, rarely pentamerous, more frequently tetramerous; sepals usually four, small tooth-like or absorbed; petals usually four, small, greenish to yellowish to white (*Cornus florida*), rarely pink or crimson; stamens four or five, alternate to the petals and inserted with the sepals and petals epigynously around and between the nectar disc; pistil syncarpous, bicarpellate, rarely tricarpellate; ovary as many celled with one pendulous ovule in each cavity; style usually simple, ending in rounded or slightly bilobed stigma. Fruit a two-seeded drupe. Seeds albuminous.

| Official drug | Part used    | Botanical origin | Habitat                          |
|---------------|--------------|------------------|----------------------------------|
| Cornus N.F.   | Bark of root | Cornus florida   | Eastern United States and Canada |

SUB-CLASS B.—SYMPETALÆ (GAMOPETALÆ OR METACHLAMYDEÆ)

A division of dicotyledonous plants in which the flowers possess both calyx and corolla, the latter with petals more or less united into one piece.



I. Order Ericales.—*Ericaceæ* or *Heath Family*.—Sub-herbaceous (*Chimaphila*), suffruticose (*Erica*), fruticose (*Azaleas*, *Kalmias*, etc.); rarely sub-arborescent (*Arbutus unedo* or Strawberry Tree) plants. Roots fibrous often saprophytically associated, rarely tuberous or more or less enlarged. Stem upright, ascending or creeping, more or less woody, rarely through saprophytic connection becoming soft, annual and pale above ground (*Monotropa uniflora*).

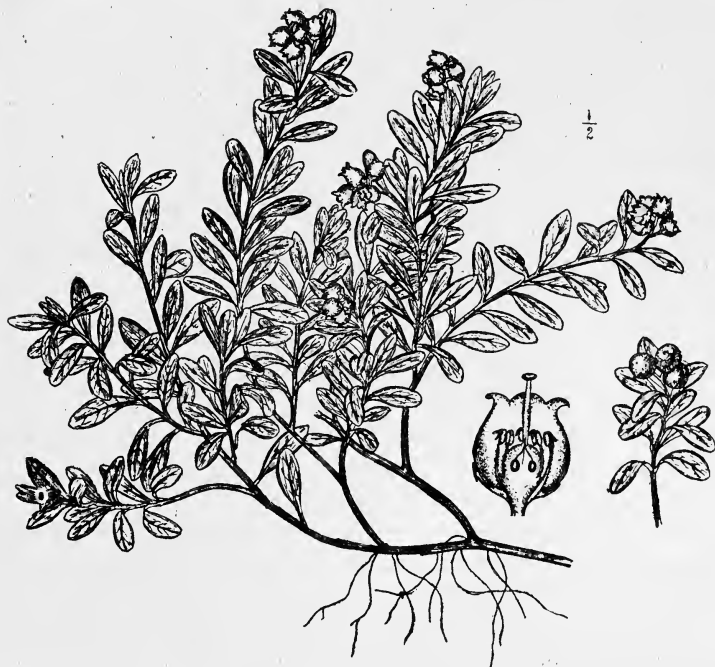

FIG. 222.—*Arctostaphylos uva ursi*—Branch, flower, and fruiting branch. (Sayre.)

Leaves alternate, simple, entire, exstipulate, rarely soft, delicate, herbaceous (*Azaleas*), usually leathery to wiry and evergreen, more rarely (*Pterospora*, *Monotropa*, etc.) becoming greenish-blue, bluish-yellow, yellowish-white to white and correspondingly saprophytic. Inflorescence typically a raceme (*Pyrola*, *Andromeda*, *Gaylussacia*, *Erica*, *Arctostaphylos Uva Ursi*, etc.) but raceme condensed into a racemose umbel (*Azalea*, etc.) or further reduced to a few flowers or, in the degraded saprophytic condition to one flower (*Monotropa*

*uniflora*): Flowers regular, passing to irregular (*Rhododendron*), pentamerous or tetramerous; sepals five to four, rarely fewer, apotosepalous, usually green, sometimes brightly petaloid; petals five more rarely four, slightly to deeply synpetalous, cup-shaped (*Kalmia*) to urceolate (*Arctostaphylos*, *Andromeda*, etc.), yellow to white or through yellow pink to scarlet to crimson to crimson-purple; stamens ten to eight in two circles of five to four each, becoming by absorption of inner circle, five to four only, hypogynous, epipetalous or epigynous; anthers two-celled, dehiscing by apical pores (*Arctostaphylos*) or apical slits; pollen sometimes agglutinated into long viscous threads; pistil five- to four-, rarely six- to eight carpels, superior, rarely semi-inferior to inferior (*Vaccinææ*); ovary as many celled as there are carpels; style elongated, filiform, usually five- to four lobed. Fruit a capsule (*Trailing Arbutus*), berry (*Vaccinium*) or false drupe (*Gaultheria*). Seeds small, anatropous

| Official drug      | Part used    | Botanical origin        | Habitat  |
|--------------------|--------------|-------------------------|--|
| Chimaphila N.F.    | Leaves       | Chimaphila umbellata    | United States, Canada, Northern Europe and Asia    |
| Uva Ursi           | Leaves       | Arctostaphylos Uva Ursi |  |
| Methylis Salicylas | Volatile oil | Gaultheria procumbens   | Northern United States and Canada, Europe and Asia |
| <b>Unofficial</b>  |              |                         |  |
| Gaultheria         | Leaves       | Gaultheria procumbens   | United States and Canada                           |

II. Order Ebenales.—*Sapotaceæ* or *Star Apple Family*.—Tropical shrubs or trees (*Palaquium*) characterized by the presence of laticiferous sacs in the pith and cortex of the stems and adjoining the veins of the leaves. Leaves alternate, exstipulate, evergreen and coriaceous. Flowers perfect, large and axillary. Fruit a berry (*Palaquium*) rarely a capsule (*Ponteria*).

| Official drug     | Part used                         | Botanical origin             | Habitat                    |
|-------------------|-----------------------------------|------------------------------|----------------------------|
| Gutta Percha N.F. | Purified coagulated milky exudate | Various species of Palaquium | Indo-China and East Indies |
|                   |                                   |                              |                            |

*Styracæ* or *Benzoin Family*.—Shrubs or low trees. Leaves alternate to opposite, entire, often acuminate. Flowers hermaphrodite, regular, rarely sub-irregular, either in condensed fascicles or solitary in the axils of the leaves; sepals and petals typically five each; corolla often white, rarely pinkish or yellowish; stamens many to four to two, perigynous or sub-hypogynous; pistil bicarpellary or four to five carpellate. Fruit either fleshy or dry, often winged and rarely as many-celled as there are carpels.

| Official drug | Part used      | Botanical origin                      | Habitat                 |
|---------------|----------------|---------------------------------------|-------------------------|
| Benzoinum     | Balsamic resin | { Styrax Benzoin<br>and other species | East Indies and<br>Siam |

III. Order *Contortæ* (*Gentianales*).—*Oleaceæ* or *Olive Family*.—Shrubs (*Forsythia*, *Chionanthus*, *Syringa*, etc.) or trees (*Fraxinus*, *Olea*, etc.) with stems possessing close white wood, and slightly swollen or enlarged nodes. Leaves opposite, decussate, simple, rarely pinnately compound (Ash). Inflorescence dichesial or scorpioid cymes but tending constantly toward condensation and so in the Lilac, the inflorescence becomes a clustered raceme of cymes (thyrsus). Flowers regular, pentamerous or tetramerous; sepals small, green, rarely petaloid, synsepalous; petals synpetalous, elongated into a narrow tube, expanding above into a stellate limb; stamens very rarely five, rarely four to three, nearly always two, epipetalous and high set on corolla tube; pistil bicarpellate, rarely of three to four carpels; ovary two-celled with two to one pendulous ovules in each cavity. Fruit either a capsule (Lilac), drupe (Olive), berry (Privet) or a winged indehiscent akene (Ash). Seeds with moderate to scanty albumen becoming occasionally exalbuminous.

| Official drug    | Part used                | Botanical origin      | Habitat                           |
|------------------|--------------------------|-----------------------|-----------------------------------|
| Manna            | Dried saccharine exudate | Fraxinus Ornus        | Southern Europe                   |
| Oleum Olivæ      | Fixed oil                | Olea Europæa          | Southern Europe, Algeria, Asia    |
| Chionanthus N.F. | Bark of root             | Chionanthus virginica | Southern United States            |
| Fraxinus N.F.    | Bark                     | Fraxinus Americana    | Northern United States and Canada |

*Loganiaceæ* or *Logania* Family.—Herbs (*Spigelia*, etc.), woody vines (*Gelsemium*, etc.) or trees (*Strychnos Nux Vomica*, etc.) with a bitter juice usually containing alkaloids. Stem, rarely herbaceous,

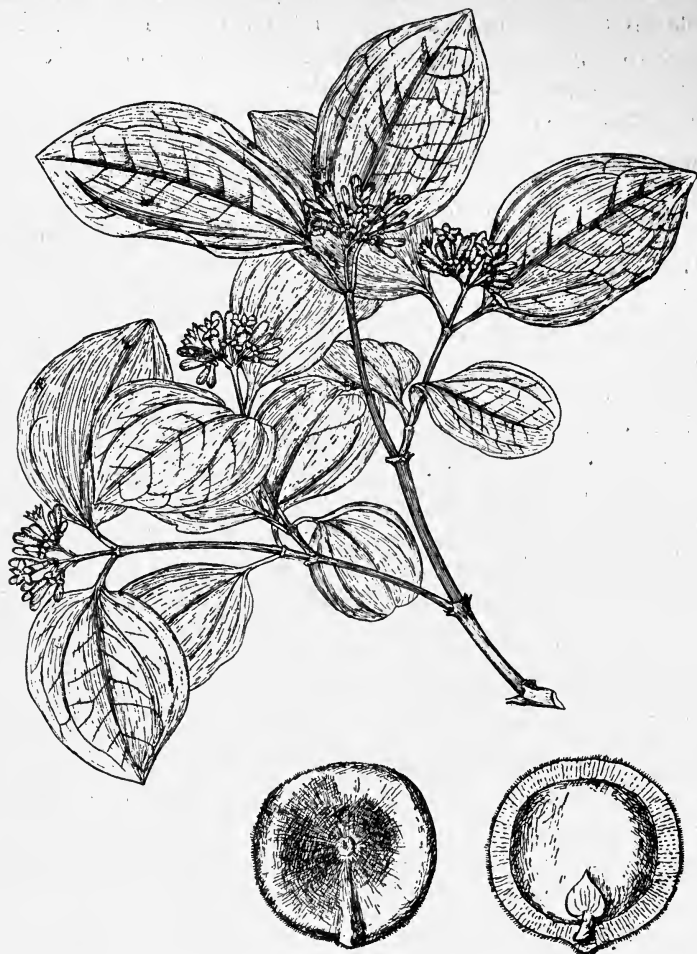

FIG. 223.—*Strychnos nux vomica*—Flowering branch and seeds. (Sayre.)

usually woody, often long climbing and rope-like (*Gelsemium*), usually with a bicollateral bundle system. Leaves opposite, stipulate

or exstipulate. Inflorescence racemose or cymose (*Spigelia*) (scorpioid cyme (*Strychnos*), sometimes condensed into solitary, axillary flowers. Flowers perfect, usually regular; calyx gamosepalous; corolla gamopetalous, hypogynous, rotate, campanulate or infundi-

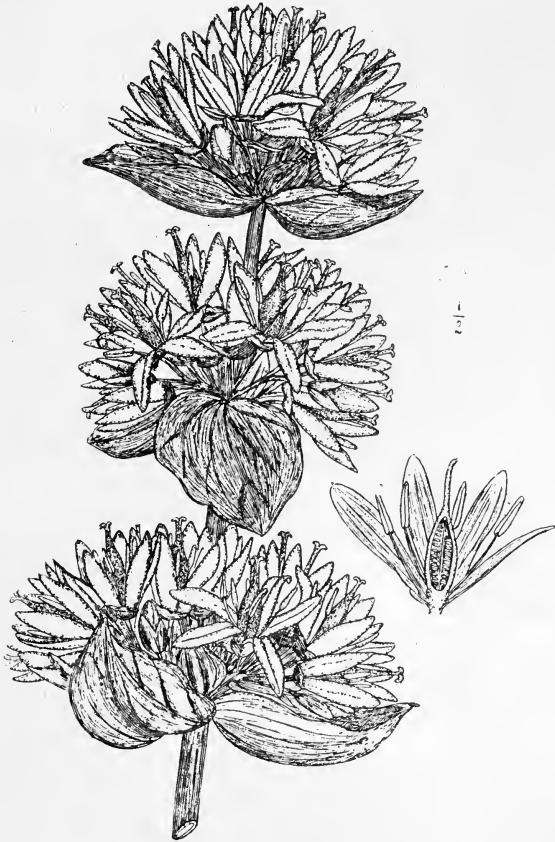

FIG. 224.—*Gentiana lutea*—Flowering head and dissected flower. (Sayre.)

buliform; stamens inserted on the corolla tube or throat and with thread-like filaments; ovary superior, two-celled; style elongate with bifid stigma; ovules numerous. Fruit usually a capsule, septicidally dehiscent (*Gelsemium sempervirens*), or loculicidally dehiscent (*Spige-*

*lia marilandica*), sometimes a berry (*Strychnos Nux Vomica*) or drupe. Seeds numerous or solitary, sometimes winged.

| Official drug | Part used         | Botanical origin       | Habitat                |
|---------------|-------------------|------------------------|------------------------|
| Nux Vomica    | Seeds             | Strychnos Nux Vomica   | East Indies            |
| Gelsemium     | Rhizome and roots | Gelsemium sempervirens | Southern United States |
| Spigelia      | Rhizome and roots | Spigelia marilandica   | Southern United States |
| Ignatia N.F.  | Seeds             | Strychnos Ignatii      | Philippine Islands     |

*Gentianaceæ* or *Gentian Family*.—Herbs often low-growing. Roots and short stems sometimes more or less thickened (*Gentiana lutea*). Leaves opposite, decussate, entire, exstipulate. Inflorescence cymose (*Gentiana lutea*) or condensing to a single, solitary, terminal flower (*Gentiana verna*, *G. acaulis*, etc.) Flowers regular, perfect, pentamerous or tetramerous, sepals five to four, green, more or less synsepalous, not infrequently everted or reflexed, corolla of five, rarely four petals, more or less synpetalous, in shape passing from open-stellate, as in *Gentiana lutea*, through many stages of connation to long-tubed, as in *Gentiana acaulis*; stamens five, epipetalous; pistil bicarpellate; ovary one-celled or incompletely two-celled; style more or less elongated with bilobed to divided stigma. Fruit a capsule. Seeds albuminous.

| Official drug   | Part used         | Botanical origin      | Habitat               |
|-----------------|-------------------|-----------------------|-----------------------|
| Gentiana        | Rhizome and roots | Gentiana lutea        | Europe and Asia Minor |
| Chirata N.F.    | Entire plant      | Swertia Chirayita     | Northern India        |
| Menyanthes N.F. | Leaves            | Menyanthes trifoliata | Europe and Asia       |
| Centaurium N.F. | Flowering plant   | Erythræa Centaurium   | Europe                |

#### Unofficial

|          |      |                    |                                  |
|----------|------|--------------------|----------------------------------|
| Sabbatia | Herb | Sabbatia angularis | Eastern United States and Canada |
|----------|------|--------------------|----------------------------------|

*Apocynaceæ* or *Dog Bane Family*.—Herbs, rarely shrubs, not infrequently clambering or climbing in habit (*Allamanda*). Stem and branches show bicollateral bundles. Stem, leaves and flowers have

latex tubes which ramify through the cortex and mesophyll tissues. Leaves alternate, opposite or verticillate, simple, entire, deciduous or evergreen. Inflorescence cymose. Flowers regular, pentamerous, rarely tetramerous; sepals five, gamosepalous, green, rarely sub-petaloid to petaloid; petals five, slightly to deeply gamopetalous, in



FIG. 225.—*Strophanthus hispidus*—Branch and seed with comose awn. (Sayre.)

shape varying from open tubular, stellate, to elongate tubular to elongate funnel-shaped, in color varying from greenish-yellow to white or from yellow to yellow-red to crimson to crimson-purple to nearly purple-blue; stamens five, epipetalous; pistil usually bicarpelate; ovary two-celled with central placentation; style more or less

elongate with terminal brush of hairs, knobbed or multifid; stigma circular band or circular spur beneath terminal style swelling. Fruit two follicles (*Apocynum*, etc.), a berry, drupe, or capsule. Seeds flattened, frequently hairy, albuminous.

| Official drug | Part used               | Botanical origin                               | Habitat                   |
|---------------|-------------------------|--|---------------------------|
| Strophanthus  | Seeds (deprived of awn) | Strophanthus<br>Kombe<br>Strophanthus hispidus | Africa                    |
| Strophanthin  | Glucoside               |  |                           |
| Apocynum N.F. | Rhizome and roots       | Apocynum cannabinum                            | United States and Canada  |
| Aspidosperma  | Bark                    | Aspidosperma<br>Quebracho blanco               | Central and South America |

*Asclepiadaceæ* or *Milkweed Family*.—Herbs or shrubs containing a milky juice, many species yielding rubber. Leaves entire, more or less fleshy, sometimes verticillate. Inflorescence usually a dichesial or scorpioid cyme. Flowers regular, pentamerous; sepals wooly, small, synsepalous; petals five, rarely four, synpetalous, elongated into awls; the corolla varying in shape from stellate to campanulate and in color from pale green to yellow, to greenish-brown, chocolate, or from white to yellow, to scarlet, to crimson, to purple, to blue; stamens five, epipetalous, fused in relation forming a cylindrical swollen mass around the central pistil; filaments flattened and furnished with a crown having various appendages; anthers two-celled, each cell containing a pollen mass (pollinium), adhering to the glandular prominences of the stigma; pistil bicarpellate, superior. Fruit typically two dry follicles (*Asclepias*), rarely becoming succulent or bladderly. Seeds numerous, compressed, imbricate with a comose appendage.

| Official drug   | Part used | Botanical origin        | Habitat          |
|-----------------|-----------|-------------------------|------------------|
| Asclepias N.F.  | Roots     | Asclepias tuberosa      | United States    |
| Condurango N.F. | Bark      | Marsdenia<br>Condurango | Peru and Ecuador |

IV. Order *Tubifloræ* or *Polemoniales*.—*Convolvulaceæ* or *Morning glory Family*.—Frequently herbaceous, more rarely sub-woody,



woody, perennial climbing plants with underground parts sometimes swollen into tuberous roots (Jalap, Sweet Potato, Wild Man of the Earth). Stems rarely short, upright or tufted, usually elongate and circumnutating in action. Vascular bundles frequently bicollateral. Leaves alternate, simple, exstipulate, varying from

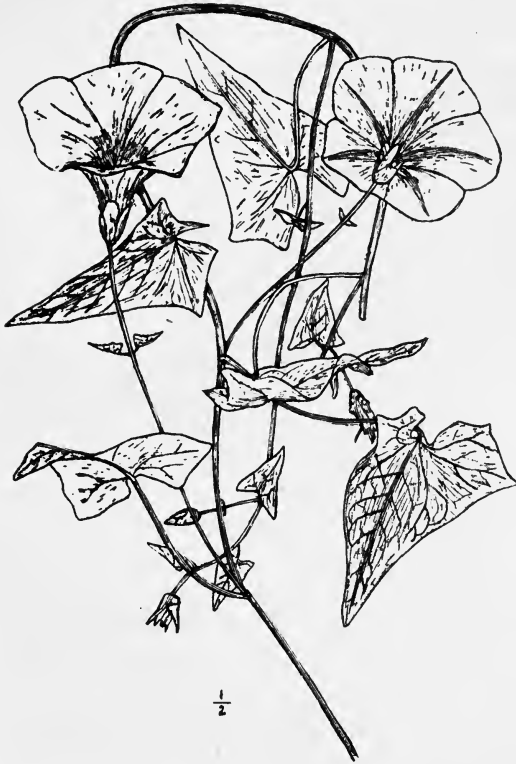

FIG. 226.—*Convolvulus scammonia*—Branch. (Sayre.)

cordate to cordate-sagittal, to broad reniform to reniform, palmately lobed to palmatifid to palmately-compound (*Ipomœa* shows all these transitions). Stem and leaves frequently contain a dull, viscous, watery to milky-white juice. Inflorescence a scorpioid cyme becoming reduced in some forms to a solitary flower. Flowers penta-

merous; sepals five, green, gamosepalous; corolla varying in shape from rotate to funnel-like with expanded mouth, in color from greenish-yellow to white or through yellowish-pink to scarlet, crimson, purple or blue; stamens five, often with the bases of the filaments expanded; pistil bicarpellate; ovary two celled, superior, often surrounded by a nectar girdle; style filiform with bilobed or bifid stigma. Fruit usually a capsule (*Exogonium*, etc.), dehiscent septifragally, rarely a berry. Seeds scantily albuminous to exalbuminous.

| Official drug     | Part used     | Botanical origin             | Habitat                        |
|-------------------|---------------|------------------------------|--------------------------------|
| Jalapa            | Tuberous root | <i>Exogonium Purga</i>       | Mexico                         |
| Scammoniaæ Radix  | Root          | <i>Convolvulus Scammonia</i> | } Asia Minor,<br>Greece, Syria |
| <b>Unofficial</b> |               |                              |                                |
| Male Jalap        | Root          | <i>Ipomœa orizabensis</i>    | Mexico                         |
| Tampico Jalap     | Root          | <i>Ipomœa simulans</i>       | Mexico                         |
| Wild Jalap        | Root          | <i>Ipomœa pandurata</i>      | United States                  |
| Turpeth Root      | Root          | <i>Operculina Turpethum</i>  | East Indies                    |

*Hydrophyllaceæ* or *Water Leaf Family*.—Annual, herbaceous, rarely perennial woody plants whose stems, branches, leaves and sepals are often viscid and glandular hairy. Leaves alternate, exstipulate, from simple linear to pinnatifid to pinnate. Inflorescence rarely expanded, usually scorpioid cymes. Flowers small to large, funnel-form in *Eriodictyon californicum*; sepals five, green; petals five, regular; corolla varying from small stellate with slightly fused petals to large rotate, campanulate or tubular, in color varying from greenish-white or yellow to rarely white, often pink, purple or blue; stamens five, rarely with alternate staminodes; pistil bicarpellate. Fruit a two-celled capsule dehiscent usually septically.

| Official drug | Part used | Botanical origin                | Habitat                   |
|---------------|-----------|---------------------------------|---------------------------|
| Eriodictyon   | Leaves    | <i>Eriodictyon californicum</i> | California and New Mexico |

*Borraginaceæ* or *Borage Family*.—Herbaceous (*Borraginææ* sub-family) or shrubby (*Heliotropææ* sub-family), plants forming a primary root and a single or often branched shoots. Leaves often divisible into expanded, sometimes large basal and alternate scattered cauline leaves. Each of these simple, exstipulate, often hairy,

rarely glabrous. Inflorescence a raceme of dichesial or scorpioid cymes, at times condensed into a dichesium of scorpioids or a simple scorpioid cyme. Flowers pentamerous, regular, passing to slight or marked irregularity (*Echium*); sepals five; green, slightly or



FIG. 227.—*Atropa belladonna*—Branch. (Sayre.)

deeply gamosepalous, often hairy; petals five, the corolla varying in shape from rotate with shallow tube (*Myosotis* and *Borage*), to tubular (*Symphytum*), to funnel-shaped in most species, in color, all transitions frequently purple-blue to blue; stamens five; pistil

bicarpellate, syncarpous, embryologically two-celled with two ovules in each cavity, but dorsal ingrowths divide ovary by time of flowering into four cells with one ovule in each cavity; style gynobasic. Fruit typically four-nutlets. Seeds solitary in each cavity and either scantily albuminous (*Heliotropææ*) or exalbuminous (*Borragineæ*).



FIG. 228.—*Hyoscyamus niger*—Flowering branch. (Sayre.)

| Unofficial                      | Part used     | Botanical origin                  | Habitat                     |
|---------------------------------|---------------|-----------------------------------|-----------------------------|
| Symphytum<br>(Comfrey)          | Root          | <i>Symphytum officinale</i>       | Europe and<br>United States |
| Cynoglossum<br>(Hound's tongue) | Herb and root | <i>Cynoglossum<br/>officinale</i> | United States               |
| Alkanet                         | Root          | <i>Alkanna tinctoria</i>          | So. Europe and Asia         |

*Solanaceæ* or *Nightshade Family*.—Stem herbaceous, rarely shrubby or arborescent, frequently with bicollateral bundles. Leaves alter-

nate, exstipulate, entire or more or less lobed, rarely compound; often glandular-hairy. Flowers in cymes; regular or rarely irregular (Petunia, Tobacco sps.), pentamerous, perfect, synphyllous; sepals green (rarely petaloid), rotate to tubular, usually persistent and accrescent; petals rotate (Solanum), to tubular (Atropa), to funnel-shaped (Tobacco), and so (1) open to all comers, or (2) to bees or wasps, or (3) to butterflies, moths; color, greenish-yellow, or greenish-white, to white, to pink, crimson, purple, rarely blue; stamens five, epipetalous, hypogynous, along with style usually forming nectar glands. Filaments short to long, anthers dehiscing longitudinally or by apical pores; pistil bicarpellate, syncarpous, with or without nectar girdle; superior ovary, two-celled with central placentation, ovules numerous, style more or less elongate with bilobed or bifid stigma. Fruit, a capsule (Tobacco, Thornapple, Henbane) dehiscing longitudinally or transversely; or a berry (potato, egg-plant, tomato, red pepper). Seeds albuminous.

| Official drug     | Part used                 | Botanical origin                   | Habitat  |
|-------------------|---------------------------|------------------------------------|--|
| Belladonnæ Folia  | Leaves                    | Atropa Belladonna                  | } Central and<br>Southern Europe<br>Asia Minor and<br>Persia |
| Belladonnæ Radix  | Root                      | Atropa Belladonna                  |  |
| Stramonium        | Leaves                    | Datura Stramonium<br>and D. Tatula | Asia and Tropical<br>America                                 |
| Hyoscyamus        | Leaves and<br>flower tops | Hyoscyamus niger                   | Europe, Asia   |
| Solanum N.F.      | Ripe fruit                | Solanum carolinense                | United States  |
| Capsicum          | Fruit                     | Capsicum frutescens                | Tropical America   |
| Dulcamara N.F.    | Twigs and stems           | Solanum Dulcamara                  | Europe and Asia  |
| <b>Unofficial</b> |                           |                                    |  |
| Duboisia          | Leaves                    | Duboisia myoporoides               | Australia  |
| Tabacum           | Leaves                    | Nicotiana tabacum                  | Tropical America   |
| Scopola           | Rhizome                   | Scopola Carniolica                 | Alps and<br>Carpathian Mts.                                  |
| Manaca            | Root                      | Brunfelsia Hopeana                 | Tropical America   |
| Paprika           | Fruit                     | Capsicum annum<br>varieties        | } America? culti-<br>vated                                   |
| Pimiento          | Fruit                     | Variety of Capsicum<br>annuum      |  |

*Scrophulariaceæ* or *Figwort Family*.—Herbs (*Linaria*, *Verbascum*, *Gerardia*, *Digitalis*, etc.), shrubs (shrubby *Veronicas*, etc.), rarely trees (*Paulownia imperialis*). Stem, branches and leaves usually green and independently vegetating, but in *Pedicularis*, *Gerardia*, *Euphrasia*, *Buchnera*, *Rhinanthus*, etc., the stem, leaves, and branches are condensed from the development of a parasitic root habit. Stems cylindrical to frequently quadrangular, especially when leaves are opposite. Leaves alternate to opposite and decussate, simple, exstipulate, often hairy, but becoming by drought or



FIG. 229.—Nightshade, or bittersweet (*Solanum Dulcamara*). (Gager.)

parasiticism reduced to scales or almost absorbed. Inflorescence a raceme of cymes (*Paulownia*) or a simple raceme (*Foxglove*, *Linaria*, etc.) or spike (*Verbascum Thapsus*) or, if leaves are opposite, often a whorl of axillary flowers or solitary axillary flowers. Flowers rarely regular, mostly irregular; calyx of five sepals condensed in *Veronica* to four through absorption of one sepal by fusion of two sepals; corolla of five to four petals, deeply synpetalous, varying from rotate (*Verbascum Blattaria*, etc.) to irregular tubular to elongate, irregular bilabiate to funnel-shaped. In color, corolla varies from greenish

to greenish-yellow or white (*Scrophularia*) to pure white or from red to purple to blue (*Veronica*). Stamens five, fertile, equal in length in a few *Verbascum* species or unequal in other *Verbascum* species to stamens four with a long sterile staminode (*Pentstemon*) to four didynamous stamens with a short petaloid staminode (*Scrophularia*) to four didynamous stamens with a minute often nectariferous staminode (*Linaria*), to frequently four didynamous stamens only, the two lateral or two anterior stamens stronger and longer (*Antirrhinum*) to two perfect stamens and two minute staminodes (*Calceolaria*) to two stamens alone developed (*Veronica*). Pistil bicarpellate; ovary two-celled with central placentation; style terminal with bilobed stigma; ovules numerous, small. Fruit a two-celled and usually many-seeded capsule. Seeds richly albuminous, anatropous or amphitropous.

| Official drug        | Part used             | Botanical origin  | Habitat                  |
|----------------------|-----------------------|---|--------------------------|
| Digitalis            | Leaves                | Digitalis purpurea  | Europe                   |
| Leptandra N.F.       | Rhizome and roots     | Veronica virginica  | United States and Canada |
| Verbasci Flores N.F. | Corollas with stamens | <div style="display: inline-block; vertical-align: middle;">           {<br/>           Verbascum<br/>           phlomoides<br/>           Verbascum<br/>           thapsiforme<br/>           Verbascum Thapsus<br/>           and other species of<br/>           Verbascum<br/>           }         </div> | Europe and Asia          |
| Verbasci Folia N.F.  | Leaves                | <div style="display: inline-block; vertical-align: middle;">           {<br/>           Verbascum Thapsus<br/>           and other species of<br/>           Verbascum<br/>           }         </div>  | Europe and Asia          |

*Pedaliaceæ* or *Sesame Family*.—Tropical herbs often thickly covered with viscous hairs. Leaves soft, usually alternate, more rarely opposite, exstipulate. Flowers irregular, pentamerous. Fruit a capsule (*Sesamum*, etc.), drupe, or rarely a one-seeded indehiscent nut. Seeds exalbuminous usually.

| Official drug            | Part used | Botanical origin                       | Habitat         |
|--------------------------|-----------|--|-----------------|
| Oleum Sesami (Benne Oil) | Fixed oil | Sesamum indicum (cultivated varieties) | Asia and Africa |

*Acanthaceæ* or *Acanthus Family*.—Usually herbaceous (*Ruellia*), rarely sub-woody or woody plants, occasionally bushy in habit, containing cystoliths in the mesophyll or epidermal cells of the leaves and in the parenchyma of the roots and stems. Leaves opposite,



FIG. 230.—*Digitalis purpurea* var. *gloxinaeflora*.



more rarely whorled, entire, exstipulate. Inflorescence a raceme of condensed cymes, becoming a simple raceme or spike, rarely condensed into a solitary terminal inflorescence. Flowers hermaphrodite, usually irregular; calyx five-cleft; corolla hypogynous, gamopetalous, more or less bilabiate, funnel-form and composed of five sepals; stamens usually four (*Ruellia*, etc.), occasionally reduced to two, as in genus *Dianthera*, didynamous or diandrous, epipetalous; pistil bicarpellate; ovary two-celled, superior, with numerous campylotropal ovules; style terminal, filiform. Fruit a capsule containing numerous curved seeds. The family is of pharmaceutic interest mainly because of *Ruellia ciliosa*, a pubescent perennial herb growing in the Eastern United States, whose rhizome and roots have frequently been admixed with or substituted for Spigelia.

*Verbenaceæ* or *Vervain Family*.—Herbs (*Verbena*), Shrubs (*Clardendron*), rarely trees (*Tectona* or Teak-wood) whose stems and branches are usually quadrangular and rarely scented. Leaves generally opposite, exstipulate, simple or compound. Inflorescence a terminal panicle of spikes (*Verbena hastata*), a cyme (*Callicarpa*) or head (*Lippia lanceolata*). Flowers white, pink or blue (*Verbena hastata*) irregular, more or less 2-lipped; calyx gamosepalous, tubular; corolla gamopetalous, hypogynous with a 4-5 fid limb; stamens generally 4, didynamous and inserted on the corolla tube or throat; pistil of 2-4 carpels, a terminal style and undivided stigma. Fruit a drupe or 2 to 4 celled berry, usually splitting into as many nutlets. Seeds exalbuminous.

| Official drug | Part used          | Botanical origin       | Habitat       |
|---------------|--------------------|------------------------|---------------|
| Verbena N. F. | Overground portion | <i>Verbena hastata</i> | United States |

*Labiata* (*Lamiaceæ*) or *Mint Family*.—Herbs producing creeping runners that spread out and root at the nodes. Stems quadrangular, rarely cylindrical in outline. Leaves opposite, decussate, mainly petiolate; leaf margin nearly always serrate, dentate or crenate. Stems and leaves further characterized by the presence of glandular hairs containing aromatic volatile oil. These hairs consist of a short one-celled stalk and a head (gland) of six or eight cells. Inflorescence a raceme or spike of verticillasters (double dichesial cymes) or, as in the Ground Ivy, a reduced verticillaster. Flowers typically

pentamerous, rarely tetramerous; sepals five, synsepalous, ribbed and forming a tubular regular or irregular bilabiate (Scullcap, etc.) calyx whose upper lip is bifid and lower trifid; corolla of five to four gamopetalous petals, hypogynous, frequently two-lipped, the upper lip bifid, the lower trifid; stamens four, didynamous, rarely one pair alone fertile and the other pair reduced, in some cases almost or



FIG. 231.—*Mentha piperita*—Flowering branch. (Sayre.)

quite to disappearing point (*Salvia* and *Monarda*); pistil bicarpellate, embryologically two-celled with two ovules in each cavity, becoming, at time of flowering, four-celled with one ovule in each cavity. Style embryologically terminal, but, upon opening of flower, deeply gynobasic, elongate, slender with two stigmatic surfaces. Fruit four nutlets enclosing as many exalbuminous seeds.

| Official drug     | Part used                                    | Botanical origin             | Habitat                          |
|-------------------|--|------------------------------|----------------------------------|
| Mentha Piperita   | Leaves and<br>flowering tops                 | Mentha piperita              | Europe                           |
| Mentha Viridis    | Leaves and<br>flowering tops                 | Mentha spicata               | Europe                           |
| Scutellaria N.F.  | Entire plant                                 | Scutellaria lateri-<br>flora | United States and<br>Canada      |
| Oleum Thymi       | Volatile oil from<br>flowering plant         | Thymus vulgaris              | Southern Europe                  |
| Oleum Rosmarini   | Volatile oil from<br>fresh flowering<br>tops | Rosmarinus<br>officinalis    | Mediterranean<br>Basin           |
| Oleum Lavendulae  | Volatile oil from<br>fresh flowering<br>tops | Lavendula vera               | Southern Europe                  |
| Cataria N.F.      | Leaves and<br>flowering tops                 | Nepeta Cataria               | Europe and Asia                  |
| <b>Unofficial</b> |  |                              |                                  |
| Salvia            | Leaves                                       | Salvia officinalis           | Southern Europe                  |
| Marrubium         | Leaves and<br>flowering tops                 | Marrubium vulgare            | Europe and Asia                  |
| Hedeoma           | Leaves and<br>flowering tops                 | Hedeoma pulegioides          | United States and<br>Canada      |
| Herba Majoranae   | Leaves and<br>flowering tops                 | Origanum Majorana            | Mediterranean<br>regions         |
| Collinsonia       | Rhizome and<br>roots                         | Collinsonia<br>canadense     | United States                    |
| Serphyllum        | Leaves and<br>flowering tops                 | Thymus Serphyllum            | Europe and Asia                  |
| Melissa           | Leaves and<br>flowering tops                 | Melissa officinalis          | Southern Europe,<br>Asia Minor   |
| Monarda           | Leaves and<br>flowering tops                 | Monarda punctata             | United States                    |
| Origanum          | Leaves and<br>flowering tops                 | Origanum vulgare             | Europe, Asia and<br>North Africa |
| Hyssopus          | Leaves and<br>flowering tops                 | Hyssopus officinalis         | Southern Europe                  |
| Summer Savory     | Leaves                                       | Satureia hortensis           | Southern Europe                  |
| Mountain Mint     | Leaves                                       | Pycnanthemum<br>Montanum     | United States                    |
| Sweet Basil       | Leaves                                       | Ocimum Basilicum             | Asia and Africa                  |
| Oil of Spike      | Vol. oil                                     | Lavendula Spica              | Europe                           |
| Motherwort        | Leaves and<br>flowering tops                 | Leonurus Cardiaca            | Europe                           |

**V. Order Rubiales.**—*Rubiaceæ* or *Madder Family*.—Herbs (*Galium*, *Mitchella*, etc.), shrubs (*Cephalanthus*, etc.), or trees (*Cinchona* species) with fibrous roots, sometimes, as in *Cephaëlis Ipecacuanha*, annularly enlarged. Roots, stems and to a less extent leaves rich in varied alkaloids, some of medicinal value. Leaves opposite, entire, stipulate and interpetiolate. Inflorescence a raceme of dichesial cymes occasionally condensing to scorpioids. Flowers perfect, often dimorphic, pentamerous or tetramerous; sepals five (*Cinchona*, etc.) but four in *Galium*, small, green, subtended with other flowers by one or two or more enlarged petaloid bracts; petals five (*Cinchona*, etc.) to four in *Galium*, stellate, varying from shallow rotate to elongate tubular or funnel-shaped with stellate limbs; stamens five to four, epipetalous; pistil nearly always bicarpellate, rarely of five to four carpels; ovary inferior, two-celled with central placentation; styles either distinct with knob-shaped stigmas or style elongate, filiform, ending in bilobed stigmas. Fruit varied, a capsule in *Cinchona*, a berry in *Coffee*, a drupe, or frequently, as in *Galium*, dry and splitting into nutlets; seeds albuminous, each with a curved embryo.

| Official drug            | Part used  | Botanical origin   | Habitat                             |
|--------------------------|--|--|-------------------------------------|
| Caffeina                 | Feebly basic principle                                   | <i>Coffea arabica</i>  | Eastern Africa                      |
| Cinchona                 | Bark   | { <i>Cinchona</i> Ledgeriana, <i>C. Calisaya</i> and hybrids of these with other <i>Cinchona</i> species } | South America                       |
| Official drug            | Part used  | Botanical origin   | Habitat                             |
| <i>Cinchona Rubra</i>    | Bark   | { <i>Cinchona succirubra</i> or its hybrids }  | South America                       |
| <i>Coffea Tosta</i> N.F. | Roasted seeds  | { <i>Coffea arabica</i> }<br>{ <i>Coffea liberica</i> }  | Eastern Africa                      |
| Gambir                   | { Prepared extract from decoctions of leaves and twigs } | { Ourouparia Gambir }  | East Indies                         |
| Ipecacuanha              | Root   | { <i>Cephaëlis Ipecacuanha</i> }<br>{ <i>Cephaëlis acuminata</i> }   | Brazil<br>United States of Columbia |

*Caprifoliaceæ* or *Honey Suckle Family*.—Shrubs or rarely herbs. Leaves entire, opposite, exstipulate or with delicate, attenuate or filiform stipules. Inflorescence varying from a raceme of shortened cymes to a capitulum. Flowers varying from regular and small



FIG. 232.—*Cephaelis ipecacuanha*—Plant and dried root. (Sayre.)

(*Sambucus*, *Viburnum*, etc.) to increasingly large, slightly irregular and ultimately very irregular in some *Loniceras* and in a few *Weigelas* and allies; calyx pentamerous, superior; corolla superior, gamopetalous, limb pentafid, small in *Viburnum* and *Sambucus* to

elongate, tubular or irregular infundibuliform in *Loniceras*; stamens five, inserted on tube of corolla and alternating with corolla segments; filaments equal or didynamous (in irregular flowers); ovary inferior, rarely five- to three-celled, usually three- or frequently two-celled; style terminal. Fruit a berry (*Viburnum*) from an inferior ovary, several celled, occasionally becoming one-celled with several to rarely one seed, or fruit a capsule (*Diervilla*, *Weigelia*). Seeds albuminous.

| Official drug                         | Part used | Botanical origin   | Habitat                                   |
|---------------------------------------|-----------|--|---|
| Sambucus N.F.                         | Flowers   | { <i>Sambucus canadensis</i><br><i>Sambucus nigra</i>              | { United States<br>Europe                 |
| <i>Viburnum</i><br><i>Prunifolium</i> | Bark      | { <i>Viburnum</i><br><i>prunifolium</i><br><i>Viburnum Lentago</i> | { Eastern and<br>central United<br>States |
| <i>Viburnum Opulus</i><br>N.F.        | Bark      | <i>Viburnum Opulus</i><br>var. <i>Americanum</i>                   | United States<br>and Canada               |



FIG. 233.—*Colocynthis*—Portion of vine and whole fruit. (Sayre.)

## VI. Order Campanulales.—

### *Cucurbitaceæ* or Gourd Family.—

Herbaceous, very often annual (*Colocynthis*, etc.), more rarely perennial (*Bryonia*, etc.), sometimes shrubby plants, the perennial and shrubby forms perennating by swollen roots, some of which are heavy and tuberous. Stems very usually grooved and ridged, often provided with roughened and barbed hairs. Tendrils are frequently produced in the axils of leaves from tendril axillary buds (Pumpkin, *Colocynthis*, Watermelon, Cucumber, Bryony, etc.). Leaves varying from entire, simple, usually deltoid to triangular through stages

of trilobate, pentalobate, deeply palmatifid to palmatipartite to seldom approaching compound (*Colocynthis*). Venation in nearly all cases

palmate. Leaves thin, herbaceous, much expanded, often hairy. Vascular bundles of petioles, branches and stems, bicollateral. Inflorescence either of loose cymes or more frequently racemes or spikes or entire axillary inflorescence may become solitary axillary. Flowers pentamerous, very rarely tetramerous, monœcious (*Bryonia alba*) or dioecious (*Bryonia dioica*); sepals five, gamosepalous, adnate to ovary; corolla of five, rarely four gamopetalous petals varying in size and shape from small to large campanulate or broadly cup-shaped (Cucumber) and in color from greenish-yellow to greenish white to pure yellow to yellowish-white to white; stamens typically five, epigynous, with anthers either joined by pairs or synantherous; carpels usually three; ovary inferior, one- to three-celled. Fruit a pepo (a berry from an inferior ovary with thick skin). Seeds flat and exalbuminous.

| Official drug            | Part used                | Botanical origin                         | Habitat                    |
|--------------------------|--------------------------|--|----------------------------|
| Bryonia N.F.             | Root                     | {<br>Bryonia alba<br>Bryonia dioica<br>} | Europe                     |
| Colocynthis              | Pulp of fruit            | Citrullus Colocynthis                    | Africa and Asia<br>Tropics |
| Pepo                     | Seeds                    | Cucurbita Pepo<br>(cultivated varieties) |                            |
| Elaterium                | Principle from elaterium | Ecballium<br>Elaterium                   | Mediterranean region       |
| <b>Unofficial</b>        |                          |  |                            |
| Watermelon Seed          | Seeds                    | Citrullus vulgaris                       | Southern Asia              |
| Momordica (Balsam apple) | Fruit                    | Momordica<br>Balsamina                   | East Indies                |

*Campanulaceæ or Bluebell Family.*—Herbs of annual or more commonly perennial growth rarely sub-shrubby or sub-woody in habit, frequently with laticiferous tubes containing a milky juice. Stem upright or feeble and spreading. Leaves alternate, simple, exstipulate. Inflorescence primitively a racemose cyme condensing into a raceme, to a sub-capitulum and ultimately to a capitulum. Flowers regular, campanulate to campanulate-elongate to elongate and deeply cleft in petals; sepals five, only slightly synsepalous, epigynous; petals five, campanulate to campanulate-tubular to tubular elongate to tubular and deeply cleft; corolla varying in color from greenish-

yellow to yellowish-white to white or again, from yellowish-purple (rarely through yellowish-pink or red) to purple to pure blue; stamens five, epigynous, usually free from corolla; nectary epigynous; pistil usually tricarpellary; ovary as many celled as number of carpels and with central placenta; style single elongate; stigmas as many as carpels. Fruit a capsule. Seeds albuminous. The plants contain inulin.

*Lobeliaceæ* or *Lobelia Family*.—Herbs, with inulin and latex contents, corresponding with *Campanulaceæ* in their vegetative parts, but differing from that group by having irregular flowers (pale blue in *Lobelia inflata*), anthers always synantherous and pistil always bicarpellate with two-celled ovary and bilobed or bilabiate stigma.

| Official drug | Part used                    | Botanical origin       | Habitat                     |
|---------------|------------------------------|------------------------|-----------------------------|
| Lobelia       | Leaves and<br>flowering tops | <i>Lobelia inflata</i> | United States and<br>Canada |

VII. Order **Aggregatæ**.—*Valerianaceæ* or *Valerian Family*.—Herbaceous often low succulent plants with creeping rhizomes, frequently strongly scented and possessing stimulating properties. Leaves frequently dimorphic; radical fascicled; cauline opposite; petiole dilated, exstipulate. Inflorescence a raceme of dichesial or scorpioid cymes. Flowers more or less irregular; calyx absent as such, but represented by a series of teeth that are incurved in the bud and flower and which expand later into a pappose crown and act in the fruit as a pappose disseminator; corolla pentamerous, gamopetalous, varying from rotate synpetalous to irregular tubular with petals diversely united, in color varying from greenish-white to white or pink (*Valeriana officinalis*) to crimson; stamens three to two or one (*Valerian*), epipetalous; pistil syncarpous; ovary usually one-celled, inferior; style filiform with three stigmatic surfaces. Fruit an akene from inferior ovary crowned by a persistent expanded pappose calyx rudiment. Seeds anatropous, exalbuminous.

| Official drug | Part used            | Botanical origin             | Habitat         |
|---------------|----------------------|------------------------------|-----------------|
| Valeriana     | Rhizome and<br>roots | <i>Valeriana officinalis</i> | Europe and Asia |

*Compositæ* (*Asteraceæ*) or *Daisy Family*.—Herbs, rarely shrubs or trees, of annual or perennial habit, and with watery or milky juice.



Inulin is present in cell sap of parenchyma. Leaves alternate, rarely opposite, simple to compound, exstipulate. Inflorescence a capitulum or a raceme of capitula, each capitulum surrounded by an involucre or protective whorl of bracts, and composed of numerous



FIG. 234.—*Valeriana officinalis*—Plant and rhizome. (Sayre.)

lum or a raceme of capitula, each capitulum surrounded by an involucre or protective whorl of bracts, and composed of numerous

florets that may be: (a) wholly regular, tubular and hermaphrodite (Thistle, etc.); or (b) central florets as in (a), but marginals strap-shaped or ligulate and usually pistillate (Daisy, Dahlia, etc.); or (c) florets all ligulate and hermaphrodite (Dandelion, Chicory, etc.); or (d) florets in part or in whole bilabiate (Mutisia, etc.). Flowers

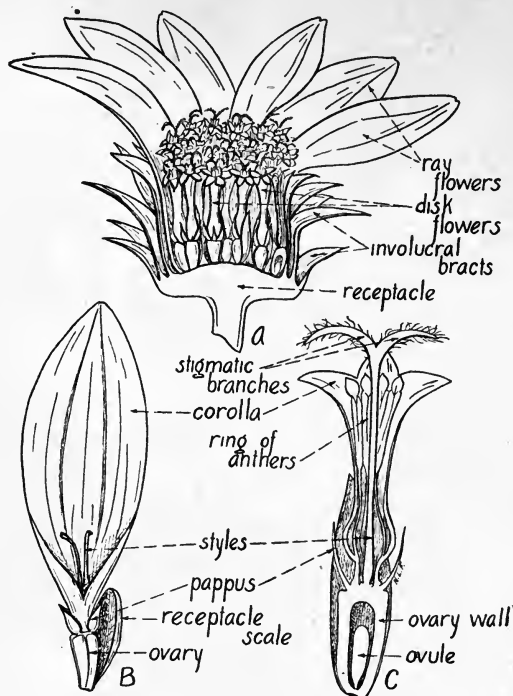

FIG. 235.—Capitulum of a composite Jerusalem artichoke (*Helianthus tuberosus*). A, lengthwise section of capitulum,  $\times 1$ ; B, ray flower,  $\times 6$ ; C, disk flower, cut lengthwise,  $\times 6$ . (A after Baillon, B and C, Robbins.)

small (florets) closely crowded, pentamerous, shaped as above, with ovary inferior and other floral parts superior. Sepals rudimentary, tooth-like (Sunflower), or reduced to a pappose or hairy rudiment above ovary that is functionless during flowering, but that expands in fruit as a hairy fruit disseminator (Dandelion, Thistle, etc.); or sepals wholly absorbed (Daisy). Petals synpetalous, tubular, ligu-

late or rarely bilabiate, greenish-yellow to white, or through pink-crimson and purple to blue (Chicory). Stamens five, epipetalous, filaments distinct, anthers united into an upright anther-box (so synantherous) into which pollen is shed before or during opening



FIG. 236.—*Matricaria chamomilla*—Branch and dissected flowers. (Sayre.)

of each floret. Carpels two, syncarpous, ovary inferior, one-celled with single ovule; style simple, at first short, later elongating and by collecting hairs sweeping pollen to top of anther box, then dividing into two stigmatic surfaces with stigmatic hairs for pollen reception.

Fruit an indehiscent achene often (Dandelion, Thistle) crowned by the pappose, calyx rudiment. Seed single, exalbuminous.

| Official drug     | Part used                                    | Botanical origin  | Habitat                                     |
|-------------------|--|---|---|
| Lactucarium       | Dried milk juice                             | <i>Lactuca virosa</i>   | Europe                                      |
| Arnica            | Flower heads                                 | <i>Arnica montana</i>   | Europe and northern Asia                    |
| Matricaria        | Flower heads                                 | <i>Matricaria</i><br><i>Chamomilla</i>  | Europe and western Asia                     |
| Calendula N.F.    | Ligulate florets                             | <i>Calendula officinalis</i>  | Mediterranean basin                         |
| Senecio N.F.      | Overground parts                             | <i>Senecio aureus</i>   | United States                               |
| Absinthium N.F.   | Leaves and flowering tops                    | <i>Artemisia</i><br><i>Absinthium</i>   | United States and Canada                    |
| Eupatorium N.F.   | Leaves and flowering tops                    | <i>Eupatorium</i><br><i>perfoliatum</i>   | North America                               |
| Grindelia         | Leaves and flowering tops                    | { <i>Grindelia camporum</i><br><i>Grindelia cuneifolia</i><br><i>Grindelia squarrosa</i> }                  | { Western North America }                   |
| Inula N.F.        | Rhizome and roots                            | <i>Inula</i> <i>Helenium</i>  | Europe and Asia                             |
| Taraxacum         | Rhizome and roots                            | <i>Taraxacum officinale</i>   | Europe and Asia                             |
| Echinacea N.F.    | Rhizome and roots                            | <i>Brauneria pallida</i>  | Central United States                       |
| Pyrethrum         | Root   | <i>Anacyclus</i><br><i>Pyrethrum</i>  | Northern Africa and southern Europe         |
| Lappa N.F.        | Root   | <i>Arctium</i> <i>Lappa</i> and other species of <i>Arctium</i>   | Europe and northern Asia                    |
| Farfara N.F.      | Leaves                                       | <i>Tussilago Farfara</i>  | Europe                                      |
| Santoninum        | Inner anhydride of santonic acid             | <i>Artemisia pauciflora</i>   | Russian Turkestan                           |
| <b>Unofficial</b> |  |   |   |
| Anthemis          | Flower heads                                 | <i>Anthemis nobilis</i>   | Europe                                      |
| Pyrethri Flores   | Flower heads (unexpanded or partly expanded) | { <i>Chrysanthemum cinerariifolium</i><br><i>Chrysanthemum roseum</i><br><i>Chrysanthemum Marschallii</i> } | { Dalmatia<br>Herzegovina<br>Western Asia } |

| Unofficial drug   | Part used                    | Botanical origin                   | Habitat              |
|-------------------|------------------------------|------------------------------------|----------------------|
| Santonica         | Unexpanded<br>flower heads   | <i>Artemisia pauciflora</i>        | Russian<br>Turkestan |
| Carthamus         | Tubular florets              | <i>Carthamus<br/>tinctorius</i>    | India                |
| Achillea          | Leaves and<br>flowering tops | <i>Achillea millefolium</i>        | Europe and Asia      |
| Tanacetum         | Leaves and<br>flowering tops | <i>Tanacetum vulgare</i>           | Europe               |
| Gnaphalium        | Leaves and<br>flowering tops | <i>Gnaphalium<br/>polycephalum</i> | North America        |
| Cichorium         | Rhizome and<br>roots         | <i>Cichorium Intybus</i>           | Europe               |
| Oleum Erigerontis | Volatile oil                 | <i>Erigeron canadensis</i>         | North America        |



FIG. 237.—Chicory (*Cichorium Intybus*). A, portion of flowering branch; B, basal leaf (runcinate-pinnatifid); C, median longitudinal section through a head, showing the insertion of the flowers; D, individual flower; E, fruit (ripened ovary), showing the persistent pappus (calyx) of short scales. (Gager.)

## CHAPTER IX

### ECOLOGY

Ecology is that department of biology which deals with the relations of plants and animals of various habitats to their environmental conditions. Every living thing is a creature of circumstance, dominated and controlled by heredity and environment. In order to exist and keep healthy it must adapt itself to the various factors of its surroundings. The environmental factors having to do with the existence and health of plants include soil constituents, air, moisture, light, range in temperature, gravity, surrounding animals and plants of other kinds.

A group of plants occurring in a common habitat constitutes what is termed a plant association or society. Plant associations may be classified either from the point of view of their order of development, as based upon the principle of succession, or upon their water relation. The latter method, appears to be the one more generally adopted, because of its ready application and will now be considered.

According, therefore, to the relation plant associations have assumed in regard to water, they may be grouped as follows:

1. *Hydrophytes* or water plants.
2. *Helophytes* or marsh plants.
3. *Halophytes* or salt plants.
4. *Xerophytes* or desert plants.
5. *Mesophytes* or intermediate plants.
6. *Tropophytes* or alternate plants.

**Hydrophytes.** The effect of an aquatic environment on the structure of water plants is most striking. The root systems are reduced both in length and number of branches. The root hairs of those immersed in the water are absent. The supportive action of the water is such that the fibrovascular elements of the stems, which usually function both for support and conduction of crude sap, are greatly reduced in size and strength. The leaves, stems and roots possess large air-spaces. The mesophyll of the leaves is

spongy and the chloroplasts motile. Stomata are entirely absent from leaves that are submerged and only present on the upper surface of floating ones, where they are nearly always open. Some of these plants have broad floating leaves and dissected submerged ones, often with thread-like divisions. The submerged parts are devoid of special protective walls *e.g.* those containing cutin or suberin. The cell sap has a low osmotic pressure. The submerged leaves often absorb more water than the roots. The free floating microscopic plants (blue-green algæ, bacteria, diatoms, desmids, etc.) form the plankton of our ponds, rivers and lakes. The free-swimming higher plants (the pleuston) comprise certain liverworts like *Riccia* and *Ricciocarpus*, water-ferns and such seed plants as the water-lettuce and water-hyacinth. The aquatic plants including the algæ, mosses and flowering plants, which live attached to rocks comprise the lithophilous benthos. Another class of aquatic plants (benthos) include those with true roots, which attach the plant to the substratum, and at most possess floating leaves. This type includes the water-lilies, the water-chestnut, the splatter docks, the floating-heart and the pondweeds.

**Helophytes.**—To this group belong plants typical to marshes. A marsh is an area with wet soil, wholly or partially covered with water and with annual or perennial herbs (never shrubs and trees) which are adjusted structurally to a mucky soil, lacking the usual supplies of oxygen. These plants likewise show an adjustment to a partial or periodical submergence. Like hydrophytes, marsh plants are for the most part perennial. They produce adventitious roots and possess horizontal rhizomes, or runners, and frequently have air chambers in roots, stems and leaves, so that they are adapted to meet the scarcity of air in wet soils. They also show a striking development of erect chlorophyll-bearing organs in the shape of leaves, in the flags, and stems, in the rushes.

The taller seed-like plants of the marsh-land, such as seed-grass (*Phragmites*), the bur-reed (*Sparganium*), the cat-tails (*Typha*), the blue flags (*Iris*), the sweet flag (*Acorus calamus*) and the papyrus (*Papyrus*) form associations known as fresh-water marshes, reed-marshes or fens. The channels or pools of water in amongst these amphibious plants are filled with true aquatic plants.

**Halophytes.**—The plants of this group live in a soil which is rich in soluble salt, usually common salt (NaCl), and on account of the fact that the osmotic force of the root is nearly inadequate to overcome that of the concentrated solution of the soil, the soil to such plants is physiologically dry. A halophyte in fact is one form of xerophyte. The most striking feature among halophytes is that they are nearly all succulent plants. The leaves of such plants, for example, are thick, fleshy and more or less translucent. They are rich in concentrated cell sap by which they are able to counteract the osmotic pull of the concentrated saline solution of the soils in which they live. Anatomically they are poor in chlorophyll, the intercellular-air-spaces are small and the palisade tissue is more abundant. Coatings of wax are found and a hairy covering, although infrequent, sometimes occurs. Coriaceous and glossy leaves, especially in tropical halophytes, are noteworthy, while in many salt-loving plants the stomata are sunken. Halophytes are found in our coastal salt marshes and on saline tidal flats in temperate and tropical countries and on the alkali flats of the interior of continents. Notable examples of these plants are the Salt Marsh Samphire, *Salicornia ambigua*, the Mangroves (*Rhizophora*) and the Bald Cypress (*Taxodium*).

**Xerophytes.**—The plants of this group, like the halophytes, are adjusted to live in a soil which is physiologically dry. The soil may owe this condition to its physical nature, such as porosity (sand), or to the presence of humic acids, or by chemical action, which inhibits the absorption of water. They are adapted to meet the conditions of strongest transpiration and most precarious water supply. To meet such conditions of physiological drought, the plants show various structural adaptations. In deserts, where the atmospheric precipitations are less than a certain limit, the plants acquire a xerophytic structure, such as succulency, water storage tissue, associated frequently with mucilage, lignified tissues, thick cuticle to the leaves depressed, stomata (frequently in pits), reduced transpiration surfaces and thorns. Mechanical tissues like wood and bast fibers attain their highest development in these plants. Cacti and the century plant (*Agave*) are types of xerophytes while many bog plants like the cranberry and Laborador tea, with leathery leaves, are xerophytic.



**Mesophytes.**—These are plants that grow in soil of an intermediate character which is neither specially acid, cold or saline, but is sufficiently well supplied with water and rich in the elements required for plant growth. Plants which grow under such conditions do not have structures by which transpiration is closely controlled. They have large leaves frequently toothed and incised, with numerous stomata usually on the lower surface and small intercellular air-spaces. The leaves and stems are usually of a fresh green color. Typical of the mesophytes are the grasses and most of the annual and biennial herbs of temperate regions.

**Tropophytes.**—This term was first introduced by Schimper in 1898 for land plants which have deciduous leaves and whose conditions of life are, according to the season of the year, alternately those of mesophytes and xerophytes. The mesophytic condition is found in summer, when the trees, shrubs and perennial herbs, included in this group, are in full leafage, and when, owing to the regular supply of rain during the growing season, the soil is plentifully supplied with water to meet the demands of these plants during the period of active transpiration. During the winter they are xerophytes. The cold of winter freezes the water in the soil so that the transpiration is reduced to a minimum, and this is associated with the fall of the leaves of the trees and shrubs and the death of the overground parts of the perennial herbs which spring up each year from their underground parts. The vegetation of cold temperate regions is mainly tropophytic.

The deciduous trees and shrubs also known as the broad-leaved plants and the summer-green plants form the principal tropophytes. The deciduous forests, which include the oaks, the beeches, the ashes, the maples, the walnuts, the chestnuts, cover a great part of eastern and western China, central Europe (England, France, Belgium, Germany) and eastern Australia, and are coincident with the countries occupied by the most civilized races of man, such as the Americans, Europeans, Chinese and Japanese. The cold temperate climatic conditions which have determined the distribution of the forest trees have been influential also in the development of the energetic races of mankind.

## GLOSSARY

- Abor'tion.**—The imperfect or non-development of an organ.
- Acaules'cent.**—Without an obvious aerial stem.
- Achene'** (akene).—A small, dry, one-celled indehiscent fruit in which the seed coat and pericarp (fruit wall) are not firmly attached.
- Achlamy'deous.**—Destitute of calyx and corolla.
- Acic'ular.**—Applied to crystals of calcium oxalate, etc. that are slenderly needle-shaped.
- Acrop'etal.**—Development from outside (below) toward the inside (above).
- Acu'minate.**—Tapering gradually to a long point.
- Acute'.**—Sharp-pointed, the point being less than a right angle.
- Ad'nate.**—Applied to the growing together of unlike parts.
- Adventi'tious.**—Applied to roots and buds that are out of their ordinary position.
- Aestiva'tion.**—Arrangement of the parts of the flower in the bud.
- Albu'men.**—Nutritive material stored in the embryo, endosperm, or perisperm.
- Al'ternate.**—Applied to leaves, buds, etc. that are arranged singly (one after another) at the nodes.
- Albur'num.**—Sapwood.
- Am'ent.**—A scaly spike-like inflorescence. Another name for catkin.
- Amor'phous.**—Without definite shape.
- Amphit'ropous** (ovules and seeds).—Half-inverted and straight, with the hilum about the middle, and micropyle terminal.
- Amplex'icaul.**—Clasping the stem.
- Anal'ogy.**—Resemblance in function.
- Anastomo'sing.**—Applied to veins that are connected with others by cross veins, so forming a network, as with the marginal veins of *Eucalyptus*.
- Anat'ropous.**—Inverted ovules or seeds with micropyle adjacent to hilum.
- Androe'cium.**—The male system of organs in a flower.
- Androg'ynous.**—Applied to inflorescences composed of both staminate and pistillate flowers.
- Anemophi'lous.**—Wind pollinated.
- Angiosperm'ous.**—Having ovules and seeds borne within a box-like covering, the pericarp.
- An'nual.**—Producing flowers, fruit and seed within a year from the time the seed germinated and then dying completely.
- An'nular.**—Ring-like.
- Ante'rior.**—The front region.
- An'ther.**—That portion of a stamen which bears the pollen.
- An'theridium.**—Male sexual organ of Thallophytes, Bryophytes and Pteridophytes.

- An'therozoid.**—A male sexual cell formed within an antheridium.
- An'thophore.**—A lengthened internode of the receptacle between calyx and corolla.
- Apet'alous.**—Without petals, as in the oaks, etc.
- Apocar'pous.**—Carpels separate and distinct.
- Apopet'alous.**—Petals separate and distinct.
- Aposep'alous.**—Sepals separate and distinct.
- Archeo'nium.**—A multicellular female sexual organ.
- Ar'il.**—An accessory seed covering outside of the testa and arising at or about the hilum, as in *Euonymus*.
- Ar'illode.**—A fake accessory seed covering outside of the testa, as in *Nutmeg*, and arising from the dilatation of the micropyle.
- Aris'tate.**—Having a stiff bristle-like termination.
- Ascend'ing.**—Growing obliquely upward.
- As'cus.**—Spore case of an Ascomycete fungus.
- Atavism.**—Reversion to ancestral type.
- Auric'ulate.**—Ear-like.
- Awn.**—A bristle-like structure that branches along its axis.
- Ax'il.**—Angle formed by branch, leaf or bud with the stem.
- Ax'illary.**—In the axil.
- Bac'cate.**—Berry-like.
- Bärb.**—A short bristle usually bent back.
- Bäst.**—Applied to the phloem region but mainly to the fibrous portion thereof.
- Beard'ed.**—Furnished with long hairs.
- Ber'ry.**—A fleshy fruit whose mesocarp and endocarp are fleshy and frequently succulent throughout, and with seeds imbedded therein, as *tomato*, *capsicum*, *belladonna*, etc.
- Bi.**—A prefix of the Latin language indicating two, twice or doubly.
- Bien'nia.**—Applied to plants that live for more than one year but not longer than two years.
- Bila'biate.**—Two lipped.
- Bläde.**—Expanded part of a leaf.
- Bloom.**—The whitish and waxy secretion of epidermal cells, as in the stems of *Sugar Cane* or the leaves of *Cabbage*.
- Bräct.**—A modified leaf, frequently scale-like, appearing on inflorescence axes.
- Brac'teole** (bracteolar leaf).—A modified leaf found on pedicels.
- Büd.**—A rudimentary stem.
- Bulb.**—A very short scaly underground stem.
- Bul'bils.**—Small underground bulbs, as in *garlic*.
- Bul'blets.**—Small above ground bulbs, as in the tree onions.
- Cadu'cous.**—Falling with the opening of the flower, as the calyx of *Papaver*.
- Ca'lyx.**—The outermost whorl of floral leaves.

- Cam'bium.**—The growing meristematic layer of a vascular bundle.
- Campan'ulate.**—Bell shaped.
- Campylo'tropous.**—Applied to ovules or seeds that are curved so as to bring the apex and base near together.
- Canes'cent.**—White or gray from a coating of fine hairs.
- Capillit'ium.**—A network of filaments among spores, as in slime molds, puff balls, etc.
- Cap'itate.**—Shaped like a head.
- Caprification.**—The process of pollinating figs artificially.
- Cap'sule.**—A dry, dehiscent fruit of two or more carpels.
- Car'pel.**—A transformed leaf bearing one or more ovules, a simple pistil; a part of a compound pistil.
- Car'pophore.**—A slender stalk, the prolongation of the receptacle, to which the inferior akenes (mericarps) of the *Umbelliferae* are attached.
- Caryop'sis.**—A dry, indehiscent, one seeded fruit of the grasses or cereals in which the fruit wall (pericarp) and seed coat firmly adhere.
- Cat'kin.**—A scaly spike of flowers.
- Cau'date.**—Tailed.
- Caules'cent.**—With an obvious aerial stem.
- Cau'line.**—Pertaining to the stem.
- Centrif'ugal.**—Applied to a flower cluster in which the terminal or central flower blossoms first.
- Centrip'etal.**—Applied to a flower cluster in which the lower or outer flowers bloom first.
- Chaff.**—The glumes and paleas of grains; the scaly hairs on the stipes of ferns; the bracts subtending each floret in some heads of *Compositae*.
- Chala'za.**—That portion of the ovule marked by the junction of the integuments with the nucellus.
- Chasmo'gamous.**—Pertaining to flowers that regularly open.
- Chlamy'dospore.**—Thick walled spore formed within the hyphae of smuts.
- Chlo'rophyll.**—The green coloring matter of all green plants.
- Chloroplas'tid.**—A protoplasmic body in the cells of green parts of plants containing chlorophyll.
- Chro'matin.**—That portion of the nucleus which is readily colored by a basic dye. The substance that carries the hereditary characters from parent to offspring.
- Chromoplas'tid.**—A protoplasmic body in the cells of certain parts of plants containing a pigment other than chlorophyll.
- Chro'mosome.**—One of the bodies into which the chromatin of the nucleus is resolved during indirect nuclear division.
- Cil'ia.**—Vibratory hair-like protoplasmic outgrowths of zoöspores, bacteria, gametes, etc.
- Circumnuta'tion.**—The repeated bending in different directions of the growing tips of stems of climbing plants.

- Cir'cinate.**—Rolled inward from apex toward base, as the young leaves of ferns.
- Circumscis'sile.**—Applied to the splitting open of capsules transversely into lid and pot portions.
- Clad'ode.**—A flattened branch which somewhat resembles a leaf.
- Claw.**—The narrowed base of some petals, as those of the Pink Family.
- Cleistog'amous.**—Applied to flowers that never open but are self fertilized, as in some Polygalas and Violets.
- Coch'lea.**—A spirally coiled legume.
- Coe'nocyte.**—A multinucleate cell.
- Cohe'sion.**—The union of parts of the same whorl.
- Co'hort.**—A group of natural orders.
- Coleorhi'za.**—A root sheath.
- Collat'eral.**—Applied to fibrovascular bundles in which the phloem and xylem masses are arranged side by side.
- Collen'chyma.**—Tissue composed of cells thickened at their angles.
- Columel'la.**—The end cell wall of an aerial hypha that bulges into the sporangium; also applied to the axis of a capsule.
- Col'umn.**—The united stamens and carpels in Orchids.
- Co'ma.**—A tuft of hairs, as found on the seeds of Milkweeds.
- Com'missure.**—The contiguous surfaces of two carpels as in the flowers and fruits of the Parsley Family.
- Concen'tric.**—Applied to several circles or whorls one within the other. Concentric fibrovascular bundles are those in which the xylem mass surrounds the phloem mass or vice versa.
- Concep'tacle.**—A sac bearing the fruiting organs in certain Algæ and Fungi.
- Condu'plicate.**—Folded together lengthwise as for example the bud leaves of the oak or peach.
- Conid'ia.**—Asexual spores cut off from the ends of hyphæ or sterigmata by Penicillium, Aspergillus, Peronospora, Claviceps, etc.
- Conid'iophore.**—A hypha bearing conidia.
- Conjuga'tion.**—One of the sexual methods of reproduction where two like sexual cells unite to form a zygospore.
- Con'cate.**—Applied to parts that have grown together, as the bases of two opposite leaves.
- Connect'ive.**—The continuation of the filament of the stamen that connects the two lobes of the anther.
- Conni'vent.**—Brought close together; converging.
- Con'volute.**—Rolled lengthwise from one edge as the leaves in the buds of the Wild Cherry and Plum.
- Cor'date.**—Heart shaped.
- Coria'ceous.**—Leathery in texture.
- Corm.**—A solid, swollen, fleshy underground stem.
- Corol'la.**—The inner whorl of floral envelopes composed of petals.

- Coro'na.**—A crown like appendage in the throat of the corolla, as in the flowers of *Narcissus* and *Silene*.
- Cor'tex.**—That region in dicotyl and gymnosperm roots of primary growth and in roots and stems of monocotyledons between epidermis and endodermis, in dicotyl and gymnosperm roots of secondary growth or in barks between cork cambium and phloem.
- Cor'ymb.**—A flat topped or convex centripetal inflorescence with the lowermost pedicels the longest.
- Cos'ta.**—A rib.
- Cotyle'don.**—A seed-leaf of the embryo.
- Crem'ocarp.**—The peculiar fruit of *Umbelliferae*, consisting of two inferior akenes (mericarps) separated from each other by a carpophore.
- Cre'nate.**—Applied to leaf margins having rounded teeth.
- Cren'ulate.**—The margin with fine rounded teeth.
- Crib'riform.**—Sieve like.
- Cru'ciform.**—Applied to the corolla or the calyx of flowers, the parts of which are arranged in the form of a cross.
- Crusta'ceous.**—Applied to the thallus of a lichen that closely adheres to the substratum.
- Cryp'togam.**—A plant belonging to one of the divisions of the vegetable kingdom below the Spermatophytes.
- Crys'talloid.**—A protein body found in the aleurone grains of seeds or underground parts.
- Culm.**—A jointed stem of a grass or sedge.
- Cu'neate.**—Wedge-shaped.
- Cu'pule.**—Applied to the concave involucre enclosing the glans of an acorn but also to other cup shaped parts of plants.
- Cu'ticle.**—A thin covering of a waxy substance called cutin on the outer wall of epidermal cells.
- Cus'pidate.**—Tipped with a sharp rigid point.
- Cyme.**—A more or less flat topped determinate inflorescence.
- Cy'mose.**—Cyme-like.
- Cytol'ogy.**—The study of cells and their contents.
- Cy'toplasm.**—The cell protoplasm outside of the nucleus.
- Decan'drous.**—Having ten stamens.
- Decid'uous.**—Applied to leaves which fall in autumn, to plants bearing such leaves and to the calyx and corolla which fall shortly after blossoming before the development of the fruit.
- Dec'linat.**—Curved or bent downward.
- Decom'pound'.**—Several times compounded, as the leaf-blades of *Cimicifuga*.
- Decum'bent.**—Erect at base, then lying on the ground, with the end rising.
- Decus'sate.**—Applied to opposite leaves when the pairs stand at right angles to each other along the stem.

- Dehis'cence.**—Splitting open.
- Deliques'cent.**—Applied to a tree whose trunk or main stem is lost in branches.
- Del'toid.**—Having the shape of the Greek letter Δ.
- Den'tate.**—Having broad acute marginal teeth pointing outward.
- Dentic'ulate.**—Finely dentate.
- Dermat'ogen.**—The generative tissue that gives rise to epidermis.
- Deter'minate.**—Applied to inflorescences on which flowering begins with the terminal bud, thus ending the elongation of the stem bearing the flowers.
- Diadel'phous.**—Applied to stamens whose filaments are united at their edges into two sets.
- Diageot'ropic.**—Applied to a plant organ that assumes a horizontal position.
- Dian'drous.**—Possessing two stamens.
- Di'astase.**—A ferment found in germinating seeds and fungal hyphæ which changes starch into maltose.
- Dichlamyd'eous.**—Pertaining to flowers that possess both calyx and corolla.
- Dichog'amy.**—The maturation of one set of sexual organs before the other.
- Dichot'omous.**—Forked.
- Dic'linous.**—Pertaining to the stamens and carpels being found in separate flowers.
- Dicot'yle'don.**—A plant whose embryo possesses two seed leaves or cotyledons.
- Dig'itate.**—Referring to a compound leaf whose leaflets come off at the end of the petiole.
- Dimor'phism.**—Having two forms of flowers, one with long styles and short stamens, the other with short styles and long stamens; the occurrence of two distinct forms.
- Dioe'cious.**—Applied to species having two kinds of individuals, male and female.
- Dissect'ed.**—Cut deeply into numerous divisions.
- Dissep'iment.**—A partition separating cells in a compound ovary or fruit.
- Dis'tichous.**—Pertaining to the arrangement of leaves in two rows.
- Divi'ded.**—Segmented to the mid-rib or base.
- Dorsoven'tral.**—Having distinct upper and lower surfaces.
- Dor'sum.**—The back of an organ. The lower surface of a foliage or floral leaf.
- Down'y.**—Covered densely with soft hairs.
- Drupe.**—A one-celled, one-seeded fruit whose endocarp is stony.
- Drupe'let.**—A small drupe.
- Duct.**—A tubular element found in the xylem region of a fibrovascular bundle.
- Dura'men.**—Heartwood.
- E- or Ex-**, A prefix meaning devoid of, outside of, or away from.
- Eccen'tric.**—Deviating from the center. Applied to the hila of starch grains which are outside of the center, also to woody plants which develop more rapidly on one side than on the other.
- Echin'ulate.**—Beset with small prickles or spines.

- Ech'inate.**—Beset with prickles or spines.
- Ec'toplasm.**—A clear layer of protoplasm just beneath the cell wall.
- Egg-Appara'tus.**—The ovum and two synergids at the micropylar end of the embryo sac.
- El'ater.**—An elastic spiral filament attached to the spores of some Liverworts and Horsetails and aiding in their dispersal when mature.
- Emar'ginate.**—Notched at the apex.
- Em'bryo.**—A rudimentary plant found within the seed.
- Embryol'ogy.**—The study of the embryo and its development.
- Em'bryo-sac.**—A large cell within the nucleus of the ovule in which the embryo is formed after fertilization.
- En'docarp.**—The inner layer of the pericarp.
- Endoder'mis.**—A layer of cells forming the innermost boundary of the cortex and surrounding the fibrovascular region.
- En'dogen.**—A Monocotyledon.
- Endog'enous.**—Applied to the axes of Monocotyl plants that do not increase materially in diameter.
- En'dophyte.**—A plant which grows within the tissues of another.
- En dosperm.**—A mass of cells formed in the embryo sac of ovules. they mature to form seeds.
- En'dospore** —The inner wall of a spore.
- Endothe'cium.**—A zone of one or more layers within the exothecium of an anther.
- En'siform.**—Sword-shaped.
- Entomoph'ilous.**—Insect pollinated.
- En'tophyte.**—See Endophyte.
- Ephem'eral.**—Lasting for a brief period (a day or so).
- Epica'lyx.**—A whorl of bracts resembling the calyx but below it.
- Epi'carp.**—The outer layer of the pericarp.
- Epicot'yl.**—The portion of the embryo axis above the cotyledon or cotyledons.
- Epider'mis.**—The outer covering layer of cells of plants, sometimes later replaced by cork.
- Epig'ynous.**—Applied to floral leaves that appear to be inserted upon the ovary.
- Epi'pet'alous.**—Upon the corolla.
- Epi'phyte.**—An air plant. A plant growing on another plant but not necessarily nourished by it.
- Epi'thelium.**—A delicate layer of cells lining an internal cavity.
- Eq'uitant.**—Applied to leaves, as in Iris, when they all spring from a rhizome and are successively folded on each other toward their bases.
- Eryth'rophyll.**—The red coloring matter of leaves.
- Estiva'tion (Aestiva'tion).**—The arrangements of the floral organs in the flower bud.
- Etae'rio.**—An aggregate fruit like the Raspberry or Blackberry, the product of a single flower, consisting of an aggregation of drupelets on a receptacle.
- E'tiolation.**—The bleaching of green parts of plants when kept in the dark for some time.



- Evolu'tion.**—The presumable theory that all forms of living things existing today have been derived from others previously existing, either by direct descent or by common ancestry.
- Exalbu'minous.**—Applied to a seed in which the nourishment is stored in the embryo during the growth of seed from the ovule stage.
- Excen'tric.**—See Eccentric.
- Excres'cence.**—A morbid outgrowth.
- Excre'tion.**—Getting rid of nitrogenous waste.
- Excur'rent.**—Applied to trees, the main stems of which do not disappear in branches but grow erect to the summit ending in a terminal bud. The opposite of Deliquescent.
- Exfo'liate.**—To shed layers of bark. To cast off layers of tissue.
- Ex'ine.**—The outer wall of a pollen grain.
- Ex'ocarp.**—The outer layer of the pericarp.
- Exog'eous.**—Applied to the axes of Gymnosperms and Dicotyledons which increase materially in diameter.
- Ex'ogens.**—Plants with exogenous axes.
- Exospor'ium.**—The outer wall of a spore.
- Exert'ed.**—Applied to stamens that protrude from the throat of the corolla.
- Exstip'ulate.**—Without stipules.
- Ex'tine.**—The outer coat of a pollen grain.
- Extrorse'.**—Applied to anthers which face outward, away from the gynœcium.
- Face.**—The free surface of an organ.
- Fal'cate.**—Scythe or sickle-shaped.
- Fam'ily.**—A sub-division of an order.
- Farina'ceous.**—Starchy or mealy.
- Fas'cicle.**—A bundle or cluster.
- Fascic'ular.**—Belonging to a bundle.
- Fascic'ulate.**—Clustered.
- Fec'ula.**—The nutritive part of a cereal.
- Fer'tile.**—Producing fruit or reproductive organs. Applied to flowers which contain functionally active stamens and carpels.
- Fertiliza'tion.**—That method of reproduction characterized by the union of two dissimilar gametes.
- Fi'brous.**—Fiber-like. Referring to root systems composed of many slender rootlets.
- Fibrovas'cular Bun'dle.**—A stringy group of fibers, vessels and cells coursing through the various organs of the higher plants and serving for support and conduction of sap.
- Fil'ament.**—The stalk of a stamen; a thread like structure.
- Filamen'tous.**—Thread-like.
- Fil'iform.**—Thread-like.
- Fim'briated.**—Fringed.

- Fis'sion.**—A form of division in which the cell separates into two equal or nearly equal parts.
- Flagel'lum.**—A whip like protoplasmic outgrowth of certain organisms or of zoöspores, serving as an organ of locomotion.
- Folia'ceous.**—Leaf-like.
- Fol'licle.**—A one chambered dry fruit that dehisces along one suture only.
- Fovil'la.**—The contents of a pollen grain.
- Frac'ture.**—The manner in which a root or other plant part breaks when subjected to sufficient pressure.
- Fron'd.**—The leaf of a fern.
- Fruit.**—A matured pistil, or ovarian portion thereof together with any closely adhering part.
- Fru'ticose.**—Shrubby.
- Fuga'cious.**—Falling off early.
- Fundamen'tal Tis'sue.**—Ground-tissue. The tissue of plants through which the fibrovascular bundles course.
- Funic'ulus.**—The stalk of an ovule.
- Fur'cate.**—Forked.
- Fu'siform.**—Enlarged in the middle and tapering toward either end.
- Gal'balus.**—A berry-like cone, as in *Juniperus*, formed by the coalescence of fleshy scales.
- Ga'leate.**—Helmet shaped.
- Gam'ete.**—A sexual cell.
- Gam'etophyte.**—The sexual generation.
- Gamopet'alous.**—Applied to a flower whose corolla is composed of petals which are more or less united at their edges.
- Gamosep'alous.**—Having the sepals more or less united at their margins.
- Gem'ma.**—An asexual bud-like structure found in the capules of Liverworts.
- Gemma'tion.**—The process of budding as seen in the yeasts.
- Gen'era.**—Plural of genus.
- Genic'ulate.**—Kneed.
- Geot'ropism.**—Response to the stimulus of gravity.
- Germina'tion.**—The sprouting of a spore or seed.
- Germ Cell.**—A reproductive cell as distinguished from a somatic or body cell.
- Gills.**—The spore bearing plates of a toadstool.
- Gla'brous.**—Smooth.
- Gland.**—A secreting structure.
- Glans.**—A nut.
- Glauc'ous.**—Covered with a bloom.
- Glo'boids.**—Small granules of calcium-magnesium phosphate found in aleurone grains
- Glob'ular.**—Spherical.
- Glom'erule.**—A head-like cyme.

- Glume.**—A floral bract of the grasses and sedges.
- Glu'ten.**—The proteid matter of cereals.
- Gonidium.**—Applied to the algal cells in lichens as well as to many forms of asexual reproductive bodies in flowerless plants
- Gon'ophore.**—An upgrowth of the receptacle between the corolla and stamens, as in *Passiflora*.
- Gynœci'um.**—The female sexual system of a flower.
- Gyn'ophore.**—An upgrowth of the receptac'le between gynœcium and andrœcium as in *Geum*.
- Gynoste'mium.**—The united stamens and style. The column of orchids.
- Hab'itat.**—The original home of a plant.
- Has'tate.**—Shaped like the head of a halberd, the basal lobes diverging.
- Head.**—An indeterminate form of inflorescence, as seen in the Daisy family, in which the flowers are in a dense cluster on the receptacle.
- Heliot'ropism.**—Response to the stimulus of light.
- Herba'rium.**—A classified collection of dried plant specimens.
- Hermaph'rodite.**—Applied to flowers which contain both sets of essential organs, not necessarily functionally active.
- Hesperid'ium.**—A large thick-skinned succulent fruit like the orange, lemon or grape-fruit.
- Heterocyst.**—A large cell, occurring in the filaments of Nostoc.
- Heterophyl'lous.**—Having more than one kind of foliage-leaves on the same plant.
- Heteros'porous.**—Producing asexual spores of more than one kind as in *Selaginella* and the rusts.
- Hex.**—A prefix of Greek origin meaning six.
- Hexag'ynous.**—Having six carpels or styles.
- Hexam'eros.**—Having the parts of the flower in 6's.
- Hexan'drous.**—Having six stamens.
- Hiberna'tion.**—Passing the winter in a dormant state of existence.
- Hi'lum.**—The scar of a seed, after the stalk of the ovule has fallen off. Also applied to the point of origin or growth of a starch grain.
- Hip.**—The fruit of a Rose, consisting of a number of akenes surrounded by a ripened concave receptacle.
- Hirsute.**—Covered with numerous long coarse hairs.
- His'pid.**—Beset with erect stiff hairs, as Borage.
- Histol'ogy.**—The study of tissues with the aid of the microscope.
- Homol'ogous.**—Having the same structural nature.
- Homos'porous.**—Producing asexual spores of only one kind.
- Hy'brid.**—A cross between two varieties or species, rarely between two genera of the same family.
- Hydroph'ilous.**—Applied to flowers that are pollinated through the agency of water currents.

**Hy'drophyte.**—A water-plant.

**Hydro'tropism.**—The response of a plant organ to the stimulus of moisture.

**Hygrosco'pic.**—The property possessed by certain cells or substances of absorbing moisture with avidity.

**Hyme'nium.**—A spore bearing membrane of a fungus.

**Hy'pha.**—A filament of the mycelium of a fungus.

**Hypo.**—A prefix of Greek origin meaning under.

**Hy'pocotyl.**—That part of an embryo p'antlet below the cotyledon or cotyledons.

**Hypocrater'iform.**—Applied to a calyx or corolla when the tube is long and slender and abruptly expands into a flat limb.

**Hypoder'mis.**—That portion of a plant organ directly beneath the epidermis.

**Hypoge'ous.**—Beneath the surface of the soil.

**Hypothe'cium.**—That portion of a thallus of a lichen directly beneath or around the apothecium.

**Hypog'ynous.**—Applied to the insertion of various floral parts on the receptacle and beneath the pistil.

**Id'ioblast.**—A cell which differs materially in form, size, character of cell wall, or contents from its neighbors in a tissue.

**Imbibi'tion.**—The taking in of water by organic bodies in such a manner as to cause them to swell up.

**Im'bricate.**—Overlapping like shingles.

**Immersed'.**—Growing entirely under water.

**Imparipin'nate.**—Applied to a pinnately compound leaf terminating with a single leaflet.

**Indef'inite.**—Applied to stamens and other organs of the flower, when too numerous to be conveniently counted.

**Indehis'cent.**—Not splitting open in a definite manner when ripe.

**Indig'e'nous.**—Native.

**Indu'sium.**—An outgrowth of the lower epidermis of many ferns that covers the cluster of sporangia.

**Inequilat'eral.**—Having unequal sides.

**Inflores'cence.**—The arrangement of the flowers on a plant.

**Infundib'uliform.**—Funnel shaped.

**Innate'.**—Applied to anthers that are attached by their base to the summit of the filament.

**Integ'ument.**—A covering.

**Intercel'lular.**—Between the cells.

**Interfaci'ular.**—Applied to a cambium layer which extends from one fibrovascular bundle to another in the stems of Dicotyledons and Gymnosperms.

**In'ternode.**—That portion of the stem between two nodes.

**Interrup'tedly-Pin'nate.**—Applied to a pinnate leaf that has either smaller or larger leaflets between those of usual size.

- In'tine.**—The inner coat of the pollen grain.
- In'tra.**—A prefix meaning within.
- Intrapet'iole.**—Applied to stipules that are between the petiole and the stem; also to buds that are beneath or inside of the base of the petiole.
- Introrse'.**—Applied to anthers that face toward the gynoecium.
- Intussuscep'tion.**—The formation of additional particles of protoplasm between those already present.
- In'ulin.**—A carbohydrate substance isomeric with starch found in the Compositæ and some other families.
- In'volucre.**—A whorl (or whorls) of bracts subtending a flower or flower cluster.
- Invol'ucel.**—A secondary involucre.
- In'volve.**—Applied to the arrangement of leaves within a bud when they are rolled inward from both sides.
- Irritabil'ity.**—That property of living matter whereby it responds to a stimulus.
- Isog'amy.**—The union of sexual cells of similar form.
- Isom'erous.**—Having the same number of parts in each whorl.
- Isostem'onous.**—Having the stamens and petals each in one whorl and of the same number.
- Isth'mus.**—Applied to the constricted portion between the two half cells in certain desmids.
- Karyokine'sis.**—Indirect nuclear division.
- Katab'olism.**—Destructive metabolism.
- Keel.**—Applied to a longitudinal ridge or elevation of cortical tissue of Senega root which extends from the crown downward. Also applied to the two inferior petals of a papilionaceous corolla which are more or less united into a body resembling the keel of a boat.
- Knee.**—A form of knot which projects upward into the air from the roots of certain trees that grow in wet soil notably the bald cypress.
- Label'lum.**—The large lip-like lower petal in the flower of an orchid.
- La'biate.**—Two lipped.
- La'bium.**—The lower lip of a labiate flower.
- Lacin'iate.**—Applied to the margins of leaves which are deeply cut into irregular narrow lobes.
- Lamel'la.**—A little plate. Applied to the layers of carbohydrate material in a starch grain which surround the growing point; also to the gills of a toadstool.
- Lam'ina.**—The blade or expanded part of any leaf.
- La'nate.**—Covered with long curled wool-like hairs.
- Lan'ceolate.**—Lance shaped.
- La'tex.**—The milk juice of a plant.
- Laticif'erous.**—Applied to the latex carrying tissue of a plant.
- Latifo'liate.**—Possessing broad leaves.

- Leaf.**—An expansion of the stem or branch in whose axil one or more branches arise.
- Leaf'let.**—A division of a compound leaf.
- Leaf-Trace.**—A fibrovascular bundle while on its way from the stem bundle to the leaf.
- Leg'ume.**—A dry, simple capsular fruit formed of a single carpel and dehiscent by both ventral and dorsal sutures.
- Len'ticels.**—Fissures in the cork of Dicotyledons formed by the swelling up and rupture of secondary cortex cells beneath.
- Lentic'ular.**—Having the shape of a double convex lens.
- Leu'coplast.**—A colorless plastid found in the cells of plants not exposed to light.
- Li'ane.**—A woody climber or twiner of tropical forests.
- Li'ber.**—The inner bark or phloem region of Gymnosperms and Dicotyledons.
- Li'briform-Cells.**—Those cells of the xylem that are thick walled and resemble bast-fibers.
- Lig'neous.**—Woody.
- Lig'nified.**—Covered with deposits of lignin.
- Lig'nin.**—A substance that adheres to the cellulose walls of certain cells and which is characterized by taking on a reddish coloration with phloroglucin and hydrochloric acid.
- Lig'ulate.**—Strap shaped.
- Lig'ule.**—A membranous appendage at the summit of the leaf-sheath in many grasses and cereals; a strap shaped corolla of a Composite.
- Liguliflo'rcus.**—Applied to Compositæ flower heads, as those of Dandelion and Chicory, which contain ligulate florets only.
- Limb.**—The spreading portion of a gamosepalous calyx or a gamopetalous corolla.
- Line.**—One-twelfth of an inch.
- Lin'ear.**—Many times longer than broad and with nearly parallel margins.
- Lobe.**—A division of a leaf or other flattened organ which is larger than a tooth but which is not a leaflet.
- Loc'ular.**—Having a cavity or cavities.
- Loculici'dal.**—Applied to the dehiscence of a capsule when it splits open along the dorsal suture.
- Loc'ulus.**—A cell or cavity of an anther, ovary, or fruit.
- Lo'ment.**—A modified jointed or multilocular legume that breaks open transversely into segments when mature.
- Lu'cid.**—Clear.
- Lu'niform.**—Half-moon or crescent shaped.
- Lu'rid.**—Dingy-brown.
- Lutes'cent.**—Yellowish.
- Ly'rate.**—Applied to a pinnatifid leaf, as that of the Turnip, in which the terminal lobe is the largest and the rest decreasing in size toward the base.
- Lysig'enuous.**—Applied to the formation of a type of intercellular-air-space

which originates through the breaking down of cell walls common to a group of cells.

**Macro.**—A prefix of Greek origin meaning large.

**Macrosporan'gium.**—A spore case containing one or more macrospores. (The nucellus in Spermatophytes.)

**Mac'rospores.**—The larger of the two different kinds of spores produced by some of the higher Pteridophytes and the Spermatophytes. (The embryo-sac in Spermatophytes).

**Macrospo'rophyll.**—The leaf bearing the macrosporangium. (The carpel in Spermatophytes.)

**Mac'ulate.**—Spotted.

**Ma'millate.**—Bearing teat-like protuberances.

**Marc'es'cent.**—Withering but not falling, dropping off.

**Marine'.**—Applied to plants which grow in the sea or ocean.

**Medul'la.**—Pith.

**Med'ullary.**—Pertaining to the pith.

**Med'ullary Rays.**—Strands of parenchyma connecting the cortex with the pith or a portion of the xylem with a portion of the phloem.

**Megasorus.**—The ovule.

**Megasporan'gium.**—See macrosporangium.

**Megaspore.**—See macrospore.

**Mem'branous.**—Thin, soft and flexible.

**Mer'icarp.**—One of the two inferior akenes which are found with the carpophore making up the cremocarp in Umbelliferae.

**Mer'istem.**—Formative tissue consisting of cells which in the living plant are in an active state of division.

**Meristemat'ic.**—Consisting of generative cells or meristem.

**Mes'ocarp.**—The middle layer of the fruit wall or pericarp.

**Mes'ophyll.**—All of the leaf parenchyma within the epidermis.

**Mes'tome.**—The conducting portion of a fibrovascular bundle.

**Metab'olism.**—The sum total of all the chemical changes which take place in a living plant.

**Metagen'esis.**—Alternation of generations. The production of sexual individuals by asexual means and asexual or neutral individuals by sexual means.

**Metamor'phosis.**—A change in the form or function of an organ or organism.

**Micro.**—A prefix of Greek origin meaning small.

**Mi'crobe.**—A minute vegetable or animal organism.

**Mi'cropyle.**—The opening between the coats of an ovule through which the pollen tube enters. The orifice or foramen in the seed coat through which the hypocotyl passes during germination.

**Microso'mes.**—Applied by Strasburger to minute particles in the protoplasm which have a high degree of refringency.

**Microso'rus.**—A lobe of the anther.

- Microsporan'gium.**—A spore case containing microspores. An anther sac.
- Mi'cros pore.**—A small spore found in a microsporangium. The pollen grain of a seed plant.
- Microspo'rophyll.**—A leaf bearing microsporangia. The stamen of seed plants.
- Mid'dle Lamel'la.**—A dividing line of calcium pectate between adjoining cells.
- Mid'rib.**—The large main central vein of a pinnately-veined leaf which is continuous with the leaf stalk.
- Mito'sis.**—Indirect nuclear division.
- Monadel'phous.**—Applied to stamens which are united by their filaments into one set as in the *Malvaceæ*.
- Monan'drous.**—Possessing only one stamen.
- Monan'thous.**—Having only a single flower on the peduncle.
- Monil'iform.**—Resembling a chain of beads.
- Mono.**—A prefix of Greek origin, meaning one or single.
- Monocar'pellary.**—Of one carpel.
- Monochlamy'deous.**—Possessing but one perianth whorl.
- Monoc'linous.**—Having both androecium and gynoecium.
- Monocotyled'onous.**—Having only one cotyledon or seed leaf.
- Monœ'cious.**—Having separate staminate and pistillate flowers on the same plant.
- Monoloc'ular.**—One chambered.
- Monom'erous.**—Applied to flowers having one part running through each whorl.
- Monopo'dium.**—A plant axis which elongates at the apex and sends off lateral branches in acropetal sequence.
- Monos'tichous.**—Arranged in one vertical row.
- Mu'ronate.**—Terminating abruptly in a small soft point.
- Multi.**—A prefix of Latin origin meaning many.
- Multicel'lular.**—Consisting of many cells.
- Multicip'ital.**—Many-headed; applied to a rhizome or root from which numerous stems arise.
- Multifa'rious.**—Composed of many diverse parts.
- Multiloc'ular.**—Many celled or chambered.
- Mul'tiple Fruit.**—A fruit composed of many small fruits, each the product of a separate flower, as in the Fig or Hop.
- Myce'lium.**—The vegetative body of a fungus consisting of intertangled hyphæ.
- Mycol'ogy.**—That branch of Botany that treats of the Fungi.
- Mycorrh'i'za.**—An association between the roots of certain plants and the mycelium of certain fungi which form an investment about their tips.
- Na'piform.**—Turnip-shaped. Somewhat globular, becoming abruptly slender and then terminating in a conical tap root.
- Nat'uralized.**—Applied to plants that have been introduced from another country.



- Navic'ular.**—Boat-shaped.
- Nec'tar.**—A sweet secretion by the flower.
- Nec'tary.**—The part of the flower which secretes nectar.
- Nerva'tion.**—The arrangement of veins in a leaf.
- Neu'tral.**—Said of flowers which possess neither stamens or carpels. Also applied to the asexual generation of plants.
- Niv'eous.**—Snow-white.
- Node.**—The place on the stem which normally shows outgrowths of a leaf, whorl of leaves or leaf modifications.
- Nodose'.**—Having swollen joints or knobs.
- Nod'ule.**—A small rounded body as a root tubercle.
- Nor'mal.**—Usual.
- Non**—Not.
- Nucel'lus.**—The body of an ovule.
- Nucif'erous.**—Nut-bearing.
- Nu'cleus.**—A dense region of protoplasm within the cell containing chromatin and usually definitely circumscribed.
- Nucle'olus.**—A small body of dense protoplasm within the nucleus.
- Nut.**—A dry, indehiscent, 1-celled, 1-seeded fruit with a stony or leathery pericarp.
- Nut'let.**—A small nut. The characteristic fruit of the *Labiatae*.
- Nutri'tion.**—That branch of Physiology which includes the absorption, distribution and assimilation of food stuffs.
- Ob.**—A prefix of Latin origin signifying inversion.
- Obcon'ical.**—Inversely cone-shaped.
- Obcor'date.**—Inversely heart-shaped.
- Oblan'ceolate.**—Lance-shaped with the broadest part toward the summit.
- Oblate'.**—Flattened at the ends or poles.
- Ob'ligate.**—Necessary, indispensable.
- Oblique'.**—Taking a position between erect and horizontal as in the case of many stems. More developed on one side than on the other as in certain leaf blades.
- Ob'long.**—Longer than broad with nearly parallel sides.
- Obo'vate.**—Ovate with the attachment at the narrower end.
- Obtuse'.**—Having a blunt or rounded end.
- O'chrea (o'crea).**—A sheathing stipule.
- Ontog'eny.**—The history of the development of an individual.
- O'öspore.**—The fertilized egg.
- Oper'culum.**—The transversely dehiscent lid or cover of a moss capsule.
- Orbic'ular.**—Circular.
- Or'der.**—A division of a class containing one or more families.
- Orthot'ropous.**—Applied to ovules or seeds which are erect, with the micropyle at the apex and the hilum coinciding with the chalaza.

- O'vary.**—The lower part of a pistil or carpel containing the ovules.
- O'vate.**—Shaped like a lengthwise section of a hen's egg and having the attachment at the broader end.
- O'vule.**—A transformed bud destined to become a seed after fertilization.
- O'vum.**—The female sexual cell.
- Pal'ate.**—A convex projection on the base of the lower lip of a personate corolla.
- Pa'lea (Pal'et).**—An inner bract of a Grass inflorescence which with the lemma incloses the flower.
- Palea'ceous.**—Chaffy.
- Pal'lid.**—Pale.
- Pal'mate.**—Divided or lobed in radiate fashion.
- Palmat'ifid.**—Palmately-cleft.
- Pandu'riform.**—Fiddle-shaped.
- Pan'icle.**—A compound raceme.
- Papilion'a'ceous.**—Having butterfly shaped flowers, as in the sub-family *Papilionaceæ* of the Leguminosæ.
- Pap'illose.**—Bearing small nipple-shaped protuberances.
- Pap'pus.**—The calyx of a Composite flower.
- Papyra'ceous.**—Papery.
- Paraph'ysis.**—A sterile filament found among reproductive organs in certain plants.
- Parasit'ic.**—Growing upon or within and deriving sustenance from another living organism.
- Paren'chyma.**—Soft cellular tissue whose units do not have tapering extremities.
- Pari'etal.**—Situated on or pertaining to the wall of an ovary or pericarp.
- Part'ed.**—Incised nearly to the mid-rib or base.
- Parthenogen'esis.**—The production of an embryo from an unfertilized egg.
- Pathol'ogy.**—The study of diseases.
- Pec'tinate.**—Comb-like.
- Ped'ate.**—Palmately parted or divided with two lateral lobes or divisions from each of which more or less linear divisions arise.
- Ped'icel.**—A branch of an inflorescence axis supporting a single flower.
- Pedun'cle.**—The main stalk of an inflorescence.
- Pellu'cid.**—Transparent, clear.
- Pel'tate.**—Shield shaped and attached by its lower surface to the support.
- Pen'dulous.**—Hanging nearly vertically downward as in the case of some ovules that hang from the sides of a locule.
- Pentam'erous.**—Applied to flowers having the number five or a multiple thereof running throughout each whorl.
- Pentan'drous.**—Having five stamens.
- Pe'po.**—A fruit of a Cucurbit; a gourd.
- Peren'nial.**—Living more than two years.
- Per'fect.**—Applied to flowers that contain both stamens and carpels.

- Perfo'liate.**—Applied to leaves which are united around the stem at their base.
- Per'ianth.**—The floral envelopes, calyx and corolla or calyx alone when corolla is absent.
- Per'iblem.**—A region of meristem lying between the dermatogen and plerome in the growing end of a root or stem. The meristem which gives rise to cortex.
- Pericam'bium.**—A zone of meristematic tissue lying just within the endodermis.
- Per'icarp.**—The wall of a ripened ovary or fruit surrounding the seed or seeds.
- Pericla'dium.**—A sheathing petiole.
- Per'icycle.**—A zone of formative tissue lying outside of the fibrovascular region and inside of the endodermis.
- Per'iderm.**—The cork tissue of plant axes.
- Perid'ium.**—The outer covering of certain fungus fructifications as puff-balls.
- Per'igone.**—See perianth.
- Perig'ynous.**—Applied to stamens and petals when they are adherent to the calyx throat, and so borne around the gynœcium.
- Per'isperm.**—The nourishing tissue of some seeds outside of the embryo sac and representing the nucellus of the ovule, which, during maturation has become laden with nutriment.
- Per'istome.**—The teeth around the mouth of the capsule in mosses.
- Perithe'cium.**—The receptacle containing asci in certain Ascomycetes.
- Persis'tant.**—Applied to parts of the flower which remain until the fruit ripens or to leaves which remain on the plant over winter.
- Per'sonate.**—Applied to a bilabiate corolla which has its throat closed by a convex projection on the base of the lower lip.
- Petal.**—One of the floral leaves of the corolla.
- Petaloid.**—Of some other color than green. Having the color of a petal.
- Pet'iole.**—A leaf stalk.
- Pet'iolule.**—The stalk of a leaflet.
- Phel'loderm.**—Secondary cortex containing chloroplasts formed by the cork cambium on its inner face.
- Phel'logen.**—The meristem which gives rise to cork and frequently secondary cortex; cork cambium.
- Phlo'em.**—That part of a fibrovascular bundle which contains sieve tissue and frequently bast fibers.
- Phloroglu'cin.**—A white crystalline substance having the formula of  $C_6H_6O_3$ , obtained by the decomposition of phloretin and from certain gummy extracts and used with hydrochloric acid as a test for lignin.
- Phycocy'anin.**—The blue pigment found in the Cyanophyceæ (Blue Green Algæ).
- Phycœryth'rin.**—The red pigment occurring in the Rhodophyceæ (Red Algæ).
- Phycophæ'in.**—The brown pigment found in the Phycophyceæ (Brown Algæ).
- Phycoxan'thin.**—A yellowish pigment occurring in some Algæ.
- Phyllocla'de.**—A flattened branch which resembles a leaf as in *Ruscus*.
- Phyl'lode.**—A dilated petiole.

- Phyl'lotaxy.**—The arrangement of leaves on stems.
- Phylloxan'thin.**—See xanthophyll.
- Phylog'eny.**—The history of the race.
- Phys'iology.**—The science which treats of the functions of living organisms.
- Phy'ton.**—A term given by Gaudichaud to an internode with a node at its upper extremity which bears one or more leaves, in the axils of which buds may appear.
- Pi'leus.**—The cap of a toadstool.
- Pilif'erous.**—Bearing hairs.
- Pilose'.**—Covered with long, straight and scattered hairs.
- Pin'nate.**—Applied to compound leaves when the leaflets are arranged along the mid-rib.
- Pinnat'ifid.**—Pinnately-cleft.
- Pinnatipar'tite.**—Pinnately-parted.
- Pinnat'isect.**—Pinnately-divided.
- Pin'nule.**—A secondary pinna.
- Pi'siform.**—Pea shaped.
- Pis'til.**—The central female organ of a flower consisting of one or more united carpels.
- Pis'tillate.**—Applied to flowers that possess one or more carpels but no fertile stamens.
- Placen'ta.**—The nourishing tissue which connects the ovules with the wall of the ovary.
- Placenta'tion.**—The arrangement of the placenta within the ovary or the pericarp.
- Plasmo'dium.**—A multinucleated naked mass of protoplasm having amœboid movement. The vegetative body of a Slime Mold.
- Plasmol'ysis.**—A contraction of the protoplasm of a cell due to the extraction of contained water under the influence of reagents of greater density than the protoplasmic sap.
- Plas'tid.**—Protoplasmic bodies of various shapes scattered about in the cytoplasm.
- Ple'rome.**—A meristem found in the apical regions of plant axes which gives rise to fibrovascular tissue.
- Pli'cate.**—Folded like a fan.
- Plumose'.**—Feathery.
- Plu'mule.**—The rudimentary bud between the cotyledons.
- Pluriloc'ular.**—Having more than one chamber or cell.
- Po'lar Body.**—A portion of a gamete budded off before fertilization.
- Pol'len.**—The fertilizing dust composed of cells produced in the anthers of flowers.
- Pollina'tion.**—The transfer of pollen from anther to stigma and subsequent germination thereon.

- Pollin'ium.**—A coherent mass of pollen grains in Orchids and Milkweeds, arranged as to be carried by insects.
- Poly.**—A prefix of Greek origin meaning many.
- Polyadel'phous.**—Applied to stamens which are united by their filaments into many sets.
- Polyan'drous.**—Having many stamens.
- Polyan'thous.**—Many flowered.
- Polyarch.**—Said of a radial fibrovascular bundle having many xylem and phloem rays.
- Polycar'pellary.**—Composed of 3 or more carpels.
- Polycar'pic.**—Fruiting successively.
- Polycephal'ic.**—Bearing many heads.
- Polycotyledon.**—A plant such as a Conifer which possesses more than 2 cotyledons or seed leaves.
- Polyem'bryony.**—Producing more than one embryo within a seed.
- Polyg'amous.**—Applied to species in which staminate, pistillate and hermaphrodite flowers are borne on the same plant.
- Polyg'onal.**—Having several or many angles.
- Polymor'phous.**—Having several to many different forms.
- Polypet'alous.**—Having distinct, disjoined petals.
- Pclyph'yllous.**—Many-leaved.
- Polysep'a'ous.**—Having distinct, disjoined sepals.
- Poly'stachous.**—Having many spikes.
- Polystem'onous.**—Possessing many more stamens than petals.
- Pome.**—A fleshy indehiscent fruit, two or more carpelled, with fibrous cartilaginous, or stony endocarp, the chief bulk of which consists of an adherent torus.
- Preflora'tion.**—See Aestivation.
- Prefolia'tion.**—See Vernation.
- Prick'le.**—A sharp, rigid outgrowth from the epidermis.
- Primor'dial.**—First formed.
- Primor'dial U'tricle.**—The outer plasma membrane. The outer layer of protoplasm adjacent to the cell wall.
- Procam'bium.**—The first formed fibrovascular tissue of any organ before differentiation has taken place into xylem and phloem.
- Procumbent.**—Lying flat on the ground.
- Proem'bryo.**—The primary stage in the development of *Chara* consisting of a single filament and a long rhizoidal cell. The suspensor in flowering plants.
- Promyce'lium.**—A short hyphal growth from resting spores of smuts or rusts upon which basidiospores are borne.
- Prosen'chyma.**—Tissue composed of elongated, taper-pointed cells.
- Protan'drous.**—A condition of hermaphrodite flowers in which the stamens mature before the carpels.

- Protog'ynous.**—Applied to hermaphrodite flowers in which the carpels are mature before the stamens.
- Prothal'lus** (Prothal'lium).—A thalloid body bearing antheridia and archegonia, produced by the germination of a spore of a Pteridophyte into a protonema which later undergoes differentiation.
- Protone'ma.**—A simple or branched green filament formed by the germination of a spore of a moss or fern.
- Protophlo'em.**—The first-formed phloem elements in a fibrovascular bundle.
- Pro'toplasm.**—Living matter.
- Pro'toplast.**—A term applied by Hanstein to the smallest body of protoplasm capable of individual action, either with or without a cell-wall, and either associated with other like units in a tissue or independent.
- Protoxy'lem.**—The first formed elements of xylem in a fibrovascular bundle.
- Prox'imal.**—Applied to the basal extremity. The attached end of an organ as opposed to the free or distal end.
- Pseudo.**—A prefix of Greek origin indicating spurious or false.
- Pseudo-Bulb.**—The fleshy bulb-like internode of an epiphytic Orchid.
- Pseu'docarp.**—A fruit which represents the product of the ripening of a single ovary as well as one or more accessory parts.
- Pseudoparen'chyma.**—A tissue consisting of the interlacing and compact hyphæ of a fungus.
- Puber'ulent.**—Covered with a fine, soft hairy coating.
- Pubes'cent.**—Covered with soft, short hairs.
- Pulvi'nus.**—An enlargement at the base of the petiole or petiolule of some leaves or leaflets, as in numerous *Leguminosæ*.
- Punc'tate.**—Dotted with small spots or minute pits.
- Pus'tular.**—Applied to surfaces having blister- or pimple-like elevations.
- Putamen.**—The stony endocarp of a drupe.
- Pyre'noids.**—Small, rounded, colorless, refractile granules embedded in the chromatophores of numerous Algæ and thought to be starch forming centers.
- Pyx'is.**—A capsule which dehisces transversely into pot and lid portions.
- Quad- or Quadri.**—A prefix of Latin origin signifying four.
- Quadran'gular.**—Four-angled.
- Quadrifo'liate.**—Applied to palmate leaves which have four leaflets arising from the summit of the petiole.
- Quinquefol'iate.**—Applied to any compound leaf that has five leaflets.
- Raceme'.**—An indeterminate inflorescence having pedicelled flowers arranged along a lengthened axis.
- Rac'emose.**—Arranged in racemes.
- Ra'chis.**—The extended portion of a peduncle.
- Rad'ical.**—Arising from the root or base of the stem.
- Rad'icle.**—The rudimentary root of an embryo plantlet.

- Ra'mal.**—Pertaining to a branch.
- Ra'mus.**—A branch.
- Ramose'.**—Branching.
- Rank.**—A row of leaves or other organs arranged vertically on a stem.
- Ra'phe (Rha'phe).**—The adherent portion of the ovule stalk in inverted and half inverted ovules and seeds.
- Raph'ides.**—Bundles of needle-shaped crystals.
- Recep'tacle.**—The shortened stem upon which the whorls of floral leaves are inserted.
- Receptac'ular.**—Pertaining to the receptacle.
- Rec'linat.**—Bent downward.
- Reclin'ing.**—See Recline.
- Recurved'.**—Curved outward or backward to a moderate extent.
- Reflexed'.**—Turned outward to backward more abruptly than Recurved.
- Reg'ma.**—A capsular fruit of 2 or more carpels that first splits into separate parts and then each of these dehisces.
- Rejuvenes'cence.**—Applied to a mode of reproduction in which the protoplasm of the cell becomes rounded out, escapes by rupture of the cell wall, forms cilia and moves about, in time developing into a new plant.
- Ren'iform.**—Kidney-shaped.
- Repand'.**—Having a slightly undulating margin.
- Re'pent.**—Creeping.
- Re'plum.**—A spurious membranous septum seen in Cruciferous fruits that persists after the valves have fallen away.
- Retic'ulate.**—Applied to markings or veins which are in the form of a network.
- Retuse'.**—Having a broad, shallow sinus at the apex.
- Rev'olute.**—Said of leaves in the bud when their margins are rolled backward.
- Rha'phe.**—See Raphe.
- Rhi'zoids.**—Absorptive organs of certain plants below the Pteridophytes that are analagous with roots of higher plants.
- Rhizome'.**—A creeping underground stem.
- Rhi'zomorphs.**—Root-like structures composed of united hyphæ and seen in certain fungi.
- Rib.**—A prominent vein or ridge.
- Rin'gent.**—Applied to the corolla of a bilabiate type whose throat is open and lips separated.
- Ripa'rious.**—Growing along the banks of rivers or other water-courses.
- Rosette'.**—A cluster of leaves or other organs.
- Ros'trate.**—Beaked.
- Ro'tate.**—Wheel-shaped.
- Rotund'.**—Rounded in outline.
- Ru'fous.**—Brownish-red.
- Rugose'.**—Wrinkled.

**Ru'minate.**—Applied to the albumen of certain seeds when the perisperm is found coursing through the endosperm in irregular fashion.

**Run'ciate.**—Applied to a pinnately-cleft leaf whose lobes are directed backward as in the Dandelion.

**Run'ner.**—A stem or branch which roots at intervals as it trails along the ground.

**Sac'cate.**—Pouch-like.

**Sag'ittate.**—Arrow-shaped.

**Sama'ra.**—A winged fruit.

**Sap'rophyte.**—An organism that lives upon decaying or dead organic matter.

**Sar'cocarp.**—The fleshy portion of a drupe or other fruit.

**Sca'brous.**—Said of leaves, etc. that are rough or harsh to the touch.

**Scalar'iform.**—Applied to tracheæ or tracheids whose walls show transversely arranged bars, resembling the rungs of a ladder.

**Scan'dent.**—Climbing.

**Scape.**—A naked peduncle arising from a root or underground stem.

**Sca'rious.**—Dry and membranous.

**Schiz'ocarp.**—A fruit that separates when mature into 2 or more indehiscent mericarps.

**Schizogenous.**—Said of intercellular-air-spaces or of reservoirs that are formed by the breaking down of the middle lamellæ of cells where several come together and the later separation of the cells at these places.

**Sci'on.**—A shoot intended for grafting.

**Scleren'chyma.**—Lignified tissue.

**Sclero'tium.**—A hardened mass of mycelium.

**Scor'pioid.**—Applied to certain cymes whose flowers are situated on alternate sides of the floral axis.

**Scutel'lum.**—A shield-shaped expansion of the hypocotyl of *Gramineæ*, which absorbs nourishment from the endosperm during germination and bales it out to the rest of the embryo.

**Sec'undine.**—The outer coat of the ovule.

**Seed.**—A fertilized and matured ovule containing an embryo.

**Se'pal.**—A leaf of the calyx.

**Se'pate.**—Possessing one or more partitions.

**Septic'dal.**—A mode of dehiscence in which the opening occurs along the line of junction of the carpels.

**Septifra'gal.**—A method of dehiscence in which the valves of a capsular fruit break away from the partitions or septa.

**Sep'tum.**—A partition between cavities in an ovary or fruit or between cells in a tissue.

**Seric'eous.**—Silky. Having a covering of fine, soft, appressed, silky hairs.

**Ser'rate.**—Toothed with teeth projecting toward the apex.

**Ser'ulate.**—Finely serrate.

**Ses'sile.**—Without a stalk.



- Se'ta.**—A bristle-like structure.
- Setig'erous.**—Bristle bearing.
- Sil'icle.**—A short silique.
- Sil'ique.**—The characteristic fruit of the *Cruciferae*, consisting of a capsule of 2 valves which separate from the replum in dehiscence.
- Sin'uate.**—Wavy margined.
- Soft Bast.**—The unligified portion of the phloem.
- Somat'ic Cells.**—The body cells of an individual, in distinction from reproductive cells.
- Sore'dium.**—A scale-like structure found on many lichens and consisting of a group of algæ cells surrounded by a network of hyphæ. When detached from the parent-plant it has the power of developing vegetatively into a mature lichen.
- Soro'sis.**—A multiple fruit, as represented by the Mulberry and Osage Orange, consisting of a swollen up, condensed and mature spike.
- So'rus.**—An aggregation of sporangia.
- Spa'dix.**—A fleshy spike more or less surrounded by a bract called a spathe.
- Spathe.**—A large bract that encloses or subtends an inflorescence.
- Spat'ulate.**—Said of flat leaves that are narrow at the base and become gradually broader toward the summit, which is rounded.
- Sperma'tophyte.**—A seed plant.
- Spermatozo'id.**—A male sexual cell. See Antherozoid.
- Spermatozo'on.**—Another name for Spermatozoid or Antherozoid.
- Sper'moderm.**—The covering of the seed.
- Sphace'lia.**—The conidia stage of *Claviceps*.
- Spic'ate.**—Arranged in a spike.
- Spic'ule.**—A small pointed outgrowth. A needle-shaped crystal.
- Spike.**—An indeterminate inflorescence consisting of sessile florets arranged along a lengthened axis.
- Spike'let.**—A secondary spike.
- Spine.**—A sharp, rigid termination of a branch as in the Honey Locust. A thorn.
- Spines'cent.**—Spiny in structure.
- Sporad'ic.**—Scattered.
- Sporan'giophore.**—The stalk or support of a sporangium.
- Sporan'gium.**—A spore case.
- Spore.**—An asexual or sexual reproductive cell usually with a highly resistant cell wall.
- Sporogo'nium.**—The asexual generation in Bryophytes and Pteridophytes.
- Spo'rophyll.**—A spore bearing leaf.
- Spur.**—A tubular or saccate appendage of some part of the flower, usually containing nectar.
- Squamose'.**—Scale-like.
- Sta'men.**—A male organ of the flower producing pollen.
- Stam'inode.**—An abortive and sterile stamen, or any body without an anther occupying the normal place of a stamen.

**Stel'late.**—Star-shaped.

**Stem.**—The ascending axis of a plant bearing leaves or leaf modifications.

**Ste'reome.**—The supporting elements of a fibrovascular bundle.

**Ster'ile.**—1. Unproductive, as a stamen without anther, flower without pistil, or pericarp without seeds. 2. Devoid of living organisms.

**Steriliza'tion.**—The process of ridding an object of all living organisms.

**Stig'ma.**—That part of a pistil or carpel which receives the pollen.

**Stipe.**—The stem of a moss; the stalk of a fern frond; the stalk of a toadstool or other fungus.

**Stip'ulate.**—Possessing stipules.

**Stip'ule.**—A modified leaf, usually blade-like and situated at the base of the leaf-stalk.

**Sto'lon.**—A slender running branch above or below the surface of the soil, either capable of taking root or bearing a bulb at its end.

**Stolonif'erous.**—Bearing stolons.

**Sto'ma.**—A breathing pore in the epidermis of higher plants.

**Stom'ata.**—Plural for stoma.

**Stomat'al Cham'ber.**—The intercellular-air-space directly beneath the stoma.

**Stri'ate.**—Marked with fine longitudinal lines or grooves.

**Strigose'.**—Covered with sharp and rigid appressed hairs.

**Strob'ile.**—A scaly multiple fruit consisting of a scale-bearing axis, each scale of which encloses one or more seeds. A cone.

**Style.**—That portion of a pistil connecting the ovary with the stigma.

**Stylopo'dium.**—The fleshy disk directly above the ovarian portion of an Umbelliferous fruit, formed by the expansion of the bases of the two styles.

**Sub.**—A prefix of Latin origin meaning under, below, subordinate, nearly or partially.

**Su'ber.**—Cork tissue.

**Subterra'nean.**—Beneath the surface of the soil.

**Su'bulate.**—Narrow and tapering to an acute end.

**Suc'culent.**—Soft and juicy or fleshy.

**Suc'ker.**—A shoot from the root or lower part of the stem or underground stem.

**Suffru'ticose.**—Applied to stems or plants that are woody at their base and herbaceous above.

**Sul'cate.**—Having longitudinal grooves.

**Super'rior.**—Said of an ovary that is not adherent to and above the calyx; also applied to a calyx which is situated on the upgrown receptacle above the ovary or to a tubular calyx whose limb appears to spring from the top of the ovary.

**Suspen'sor.**—A row of cells, representing the first development of the fertilized egg of a seed plant, upon the end of which an embryo is formed.

**Su'ture.**—The line of union of two carpels. The line of dehiscence.

**Swarm Spore.**—A spore which possesses one or more cilia for movement.

- Sycon'ium.**—The characteristic multiple fruit of the Fig, which consists of a fleshy, invaginated receptacle bearing numerous akenes.
- Symbio'sis.**—The living together of two individuals having a communion of life interests.
- Symmet'rical.**—Said of flowers when the parts of each whorl are of the same number or multiples of the same number.
- Sympet'alous.**—See Gamopetalous.
- Sym'physis.**—A union of parts.
- Syncar'pous.**—Said of fruits and gynœcia when they are formed of two or more united carpels.
- Syner'gids.**—Two nuclei in the upper region of the embryo sac above the egg nucleus.
- Syngene'sious.**—Said of stamens when their anthers are united.
- Syn'onym.**—Another name for the same thing.
- Synsep'alous.**—See Gamosepalous.
- Tab'ular.**—Flattened from above downward.
- Tape'tum.**—A layer of cells lining the cavity of an anther sac.
- Tap-Root.**—The main root coursing directly downward.
- Taxon'omy.**—The science of classification.
- Teg'men.**—The inner seed coat.
- Teleu'tospore.**—A spore produced by the Rusts toward the close of the season which forms a promycelium the next year.
- Ten'dril.**—A modified stem, stipule, leaf, or leaflet which has taken on the form of a slender appendage that is capable of coiling spirally around some object.
- Teratol'ogy.**—The study of monstrosities.
- Terete'.**—More or less cylindrical.
- Ter'minal.**—Pertaining to the end or apex.
- Ter'nate.**—In threes.
- Terres'trial.**—Growing on land.
- Tes'sellated.**—Marked like a checkerboard.
- Tes'ta.**—The outer seed coat.
- Tetra.**—A prefix of Greek origin signifying four.
- Tetracar'pellary.**—Having four carpels.
- Tetradyn'amous.**—Having six stamens, four of which are longer than the other two.
- Tetrag'onai.**—Four-angled.
- Tetram'erous.**—Said of flowers that have the number four or multiple thereof running through their various whorls.
- Tetran'drous.**—Having four stamens.
- Tetrapet'alous.**—Having four petals.
- Tetrasep'alous.**—Having four sepals.

- Te'trarch.**—Said of a radial fibrovascular bundle having 4 xylem and 4 phloem arms alternating with one another.
- Tet'raspores.**—Applied to the asexually produced spores of the *Florideæ* group of Red Algæ on account of being formed in groups of four in the mother cell.
- Tetras'tichous.**—Said of leaves when they are arranged in four vertical rows upon a stem.
- Thal'amus.**—Another name for receptacle.
- Thal'lus.**—A plant body showing no differentiation into root, stem, or leaf.
- Thermot'ropism.**—Response of living matter to the stimulus of heat or cold.
- Thorn.**—See Spine.
- Throat.**—The opening into the tube of a gamosepalous calyx or gamopetalous corolla.
- Thyr'sus.**—A compact panicle of flowers like the Lilac or Sumac.
- Tis'sue.**—An aggregation of cells of similar source, structure and function in intimate union.
- To'mentose.**—Covered with dense, matted, wooly hairs.
- Tor'tuous.**—Bent or twisted irregularly.
- To'rus.**—Another name for receptacle.
- Tra'chea.**—An elongated cylindrical or prismatic tube found in the fibrovascular system and serving for the conduction of crude sap.
- Tra'cheid.**—An undeveloped trachea usually with bordered pits.
- Transpira'tion.**—The giving off of watery vapor by the plant.
- Tri.**—Three.
- Triadel'phous.**—Having the filaments in 3 sets.
- Trian'drous.**—Possessing three stamens.
- Tri'arch.**—Applied to a radial fibrovascular bundle having three xylem and three phloem arms alternating with one another.
- Tricar'pellary.**—Possessing three carpels.
- Trich'oblast.**—An internal hair, like those projecting into the intercellular-air-spaces of the stems of certain Water Lilies.
- Trich'ogyne.**—A slender appendage to the carpogonium.
- Trich'ome.**—A plant hair.
- Trichot'omous.**—Three-branched or forked.
- Trifo'liate.**—Said of a compound leaf having three leaflets.
- Trimor'phous.**—Possessing three kinds of hermaphrodite flowers in the same species, differing in the relative length of their stamens and carpels.
- Tristichous.**—Three ranked.
- Triter'nate.**—Applied to a compound leaf whose petiole divides into three secondary petioles, each of which again divides into three tertiary petioles, each division bearing 3 leaflets.
- Trun'cate.**—Ending abruptly as if cut off or flattened at the summit.
- Tu'ber.**—A short excessively thickened end of an underground stem.
- Tu'bercle.**—A small wart-like outgrowth upon the rootlets, roots or subterranean stems of various plants.

**Tu'berous.**—Bearing or resembling tubers.

**Tu'nicated.**—Covered with successively overlapping coats as the bulb of an Onion.

**Tur'binate.**—Top-shaped.

**Turges'cent.**—Swelling.

**Tylo'sis.**—A protrusion of the wall of a cell through the pit in the wall of an adjacent vessel and appearing in the cavity of the latter.

**Type.**—An individual possessing the essential characteristics of the group to which it belongs.

**Um'bel.**—The typical inflorescence of the family Umbelliferae. A more or less flat topped indeterminate inflorescence in which the pedicels spread like the stays of an umbrella.

**Un'cifform.**—Hook-shaped.

**Un'dershrub.**—A low shrub-like plant whose base is woody and upper portion herbaceous.

**Un'dulate.**—Having a wavy margin.

**Uni.**—A prefix of Latin origin meaning one.

**Unilat'eral.**—One-sided.

**Uniloc'ular.**—One-celled.

**Unise'riate.**—Arranged in a single row, as the cells of some plant hairs.

**Ur'ceolate.**—Urn-shaped.

**Ure'dospore.**—A one-celled spore produced during the life history of a Rust.

**U'tricle.**—An akene with a bladderly pericarp as *Chenopodium* fruit.

**Vacuole.**—A cavity within the protoplasm of a cell usually containing cell sap.

**Valv'ate.**—Applied to the leaves of a flower in the bud stage when their margins meet but do not overlap.

**Valve.**—One of the halves of a diatom. One of the parts of a pericarp that splits open when ripe.

**Variety.**—A sub-species.

**Vas'culum.**—A collecting case used by botanists.

**Veg'etable.**—A plant.

**Vein.**—A strand of fibrovascular tissue in a leaf.

**Vala'men.**—An absorptive tissue composed of several layers of dead cells covering the roots of some tropical epiphytic orchids and aroids.

**Vena'tion.**—The arrangement of veins in a leaf.

**Ven'ter.**—The enlarged basal portion of an archegonium.

**Ven'tral Canal' Cell.**—A cell beneath the entrance of the neck portion of an archegonium.

**Vermic'ular.**—Worm-shaped.

**Verna'tion.**—The manner in which leaves are disposed in the bud.

**Ver'rucose.**—Wart-like.

**Verticillas'ter.**—A pair of dense cymes in the axils of opposite leaves.

**Vertic'illate.**—Whorled.

**Vessel.**—See trachea.

**Villose'.**—Covered with soft, thin, rather straight hairs.

**Virides'cent.**—Greenish.

**Vis'cid.**—Sticky.

**Vitta.**—An oil tube in the fruit of an Umbelliferous plant.

**Vol'va.**—The swollen base of the stipe in some toadstools.

**Xy'lem.**—That portion of a fibrovascular bundle which contains wood cells and fibers.

**Zoöglöe'a.**—A gelatinous mass of bacteria.

**Zo'öspore.**—A ciliated spore having the power of movement.

**Zyg'ospore.**—A spore resulting from the union of two like gametes.

**Zy'mogen.**—A microorganism capable of producing fermentation.

# INDEX

- Abies, 294  
Abies balsamea, 295  
    excelsa, 295  
Abrus precatorius, 344  
Absinthium N. F., 406  
Acacia, 91, 341, 342  
    Catechu, 344  
    Senegal, 91, 166, 342  
Acajou Gum, 356  
Acanthaceæ, 393  
Acanthus Family, 393  
Acer, 4, 359  
    spicatum, 359  
Aceraceæ, 358  
Achillea millefolium, 407  
Aconiti Folia, 327  
Aconitine, micro-chemic test for, 84  
Aconitum, 325  
    galea of, 184  
Aconitum Napellus, 325, 327  
Acorus calamus, 300, 409  
    Fig. of, 301  
Acrasiales, 3  
Actæa, 325  
Actinomyces Myricarum, 135, 224, 312  
Adhesion, 183  
Adnation, 183  
Adonis N. F., 327  
    vernalis, 327  
Æcidium, 271  
Æcium, 271  
Ægle Marmelos, 351  
Aerogens, 219  
Æthallia, 230  
Agar, 246  
Agaricaceæ, 274  
Agaricales, 274  
Agaricus, 274  
    campestris, 274, 276  
    Fig. of, 275  
Agathis loranthifolia, 295  
Agave, 410  
Agave americana, 75  
Agavose, 75  
Aggregatæ, 402  
Aggregation-body, 167  
Agropyron repens, 299  
Ailanthus Family, 351  
Akene, 207  
Albugo, 251  
Albumen, defined, 214  
    endospermic, 214  
    mode of formation, 214, 215  
    perispermic, 214  
    perispermic and endospermic, 215  
Albumens, 89  
Albuminum, 152  
Alcannin, 98  
Aldrovanda, 335  
Alectoria, 282  
Alettris farinosa, 303  
Aleurone grains, 90  
Alga-like Fungi, 247  
Algæ, 231  
    blue green, 227  
    brown, 242  
    green, 231  
    red, 246  
    siphon, 241  
Alkaloidal reagents, 83  
Alkaloids, definition of, 83  
    examples of, 83, 84  
    properties of, 83  
Alkanet, 390

- Allamanda, 384  
 Allium, 303  
     *sativum*, 303  
 Allyl-iso-sulphocyanide, 95  
 Aloe, 172, 303  
     *ferox*, 303  
     *Perryi*, 303  
     *vera*, 303  
 Alpinia officinarum, 304  
 Althæa, 91, 365  
     *Flores*, 365  
     *Folia*, 365  
     *officinalis*, 85, 365  
     *rosea*, 365  
 Amanita muscaria, 276, 278  
     Fig. of, 276  
     *phalloides*, 276, 278  
     Fig. of, 277  
 Amber, 295  
 Ament, 179  
 Ammoniacum, 378  
 Amygdala, 338  
     *Am ra*, 340  
     *Dulcis*, 338  
 Amygdalin, 96  
 Amylodextrin, 82  
 Amylum, 299  
 Anacardiaceæ, 356  
 Anacardium occidentale, 356  
 Anacyclus Pyrethrum, 5, 406  
 Anamirta cocculus, 328  
 Andreæales, 286  
 Andrœcium, 188  
 Andromeda, 379, 380  
 Anemone, 207  
 Anemone Ludoviciana, 327  
     *pratense*, 327  
     *Pulsatilla*, 327  
 Anemonella, 324  
 Anethol, 377  
 Angelica Archangelica, 377, 378  
     *atropurpurea*, 378  
 Angelicæ Fructus N. F., 377  
     *Radix N. F.*, 378  
 Angiosperm, life history of an, 53, 58  
 Angiospermous flower, diagram of  
     anatomy of, 56  
 Angiosperms, 296  
     distinctions from gymnosperms,  
         58, 59  
     resemblances between and gymno-  
         sperms, 58  
 Angiospermæ, 296  
 Aniline sulphate, 98  
 Anisum, 377  
 Annatto, 368  
 Annual ring, 147  
     thickening, 146, 147  
 Annulus, 275, 287, 290  
 Anthemis nobilis, 406  
 Anther, 188, 190  
     *adnate*, 193  
     attachment of, 193  
     dehiscence, 191  
     development of, 192  
     *extrorse*, 193  
     Fig. of, 192  
     gross structure of, 190  
     histology of, 190  
     *innate*, 193  
     *introrse*, 193  
     lobes, 190  
     syngenesious, 190  
     *versatile*, 193  
 Antheridia, 192, 194, 235  
 Anthocarp, 202  
 Anthoceros, 283  
 Anthocerotales, 283  
 Anthocyanins, 94  
 Anthophore, 183  
 Anthostema, 355  
 Anthotaxy, 177  
 Antigonum leptopus, 321  
 Antipodals, 55  
 Antirrhinum, 393  
 Apetalæ, 310  
 Apii Fructus, 378  
     *graveolens*, 378



- Apocynaceæ, 384  
 Apocynum, cannabinum, 386  
     latex of, 94  
 Apothecia, 256, 281  
 Apothecium, 256  
 Apple, 210, 338  
 Applied Botany, definition, 2  
 Apposition, growth by, 97  
 Appressorium, 249  
 Arabis, 334  
 Araceæ, 300  
 Arales, 300  
 Aralia N. F., 376  
     hispidula, 376  
     nudicaulis, 376  
     racemosa, 376  
     spinosa, 376  
 Araliaceæ, 376  
 Arbutus unedo, 379  
 Archegonia, 42  
 Archegonium, defined, 282  
 Archichlamydeæ, 309  
 Arctium Lappa, 406  
 Arctostaphylos, 380  
     Uva Ursi, 379, 380  
 Areca catechu, 300  
     nut, 300  
 Arenga saccharifera, 75  
 Aril, 214  
 Arillode, 214  
 Arisæma triphyllum, 301  
 Aristolochia, 320  
     reticulata, 321  
 Aristolochia, serpentaria, 5, 320  
     sipho, 140, 144  
 Arnica, 406  
     montana, 406  
 Artemisia Absinthium, 406  
     pauciflora, 406, 407  
 Arum Family, 300  
 Asafœtida, 377  
 Asagræa officinalis, 303  
 Asarum N. F., 321  
     canadensis, 321  
 Asarum, N. F., flower of, 320  
 Ascii, 251, 257  
 Asclepiadaceæ, 386  
 Asclepias, latex of, 94  
 Asclepias N. F., 386  
 Asclepias tuberosa, 386  
 Ascocarp, 265  
 Ascomycetes, 251  
 Ascospores, 251  
     of claviceps, 265, 266  
 Ascus, 251  
 Ash, 381  
     mountain, 74  
 Asparagine, 85  
 Asparagus, 85  
 Aspergillus, 256  
     fumigatus, 262  
     glaucus, 260  
     herbariorum, 260, 261  
     niger, 263, 264  
     oryzæ, 261, 262  
 Aspidium. See *Dryopteris*.  
 Aspidosperma Quebracho-blanco, 5,  
     386  
 Assimilation, defined, 155  
     parenchyma, 101  
 Asteraceæ, 402  
 Astragalus gummifer, 91  
 Atriplex, 323  
 Atropa, 391  
 Atropa Belladonna, 85, 391  
 Aurantieæ, 349  
 Aurantii Dulcis Cortex, 350  
     Amari Cortex, 350  
 Auriculariales, 271  
 Austrian Pine, Fig. of cones, 47  
 Autobasidiomycetes, 271  
 Auxospore, 239, 240  
 Awn, 214  
 Azalea, 191, 379  
     amena, 379  
     apples, 273  
 Azolla, 292

- Bacca, 209  
 Bacilli, anthrax, 222  
     disease producing, 224  
     types of, 220  
 Bacillus, 221  
 Bacteria, 219  
     chemical composition of, 223  
     classification according to form,  
         220, 222  
     disease producing, 224  
     forms of cell groups after cleavage,  
         223  
     morphology due to cleavage, 222  
     mounting and staining of, 224, 227  
     physical appearance of, 219, 222  
     rapidity of multiplication, 223  
     reproduction of, 222  
     sporulation, 222  
 Bacteriaceæ, 220  
 Bacterioids, 133  
 Bacterium, 220  
 Balansia claviceps, 266  
 Balsam Apple, 401  
 Balsamum Peruvianum, 343  
     Tolutanum, 343  
 Balsams, 92, 93  
 Banana, 209  
 Baneberry, 325  
 Baptisia tinctoria, 344  
 Barberry Family, 327  
 Bark, 147  
     cross-section of stem-bark of  
         *Cascara Sagrada*, 150  
     cross-section through root-bark of  
         *Euonymus atropurpureus*,  
         358  
 Barosma, 5, 349  
     *betulina*, 350  
     *serratifolia*, 351  
 Basidiomycetes, 267  
 Basidiospore, 267  
 Basidium, 267  
 Bast, fibers, 105  
     hard, 144  
     soft, 144  
 Bayberry Family, 312  
 Beech, 316  
 Beech Family, 316  
 Beets, 323  
 Begonia, leaf stalk of, 102  
     roots of, 123  
 Beggiatoa, 222  
 Beggiatoaceæ, 222  
 Belæ Fructus, 351  
 Belladonna, fruit of, 209  
 Belladonnæ Folia, 391  
     Radix, 391  
 Benzoin Family, 381  
 Benzoinum, 381  
 Berberidaceæ, 327  
 Berberis N. F., 327  
 Berry, 208  
 Beta, 323  
     *vulgaris*, 324  
     var. *Rapa*, 299  
 Betula lenta, 316  
 Betulaceæ, 316  
 Bicuculla canadensis, 334  
 Bifacial leaf blade, 172  
 Binomial plan of nomenclature, 4  
 Birch Family, 316  
 Birthwort Family, 320  
 Bistorta, 322  
 Bittersweet, 392  
 Bixa Orellana, 368  
 Bixaceæ, 368  
 Blackberry, 210, 338  
 Black Mold, 248, 249, 250  
 Bloodroot, 332  
 Blue Flag, 409  
 Blue Green Algæ, 227  
 Bluebell Family, 401  
 Bog Mosses, 286  
 Boletus, 274  
     *edulis*, 75  
     *felleus*, Fig. of, 273  
 Borage Family, 388  
 Borraginaceæ, 388

- Borragineæ, 388, 390  
 Boswellia carterii, 352  
 Botanical nomenclature, 4, 7  
 Botany, defined, 1  
     departments of inquiry, 1, 2  
 Bract, 178  
 Bracteolar leaf, 178  
 Branching, deliquescent, 139  
     excurrent, 139  
 Brassica napus 335  
     nigra, 96, 335  
 Brauneria pallida, 406  
 Brayera, 338  
 Bread mold, 248, 249, 250  
 Brewer's yeast, 254  
 Bridal wreath, 338  
 Bromelin, 96  
 Brooksilks, 236  
 Brown Algæ, 242  
 Brunfelsia Hopeana, 391  
 Brunnichia, 321  
 Bryales, 286  
 Bryonia N. F., 401  
 Bryonia alba, 401  
     dioica, 401  
 Bryony, 400  
 Bryophyllum, roots of, 123  
 Bryophyta, 282  
     outline of, 3  
 Buchnera, 392  
 Buchu, 350  
 Buckthorn Family, 359  
 Budding, 70  
 Bud, defined, 135  
 Buds, 135  
     accessory, 136  
     adventitious, 136  
     alternate, 136  
     axillary, 136  
     classifications of, 135, 136  
     flower, 135  
     leaf, 135  
     mixed, 136  
     naked, 135  
     Buds, scaly, 135  
         whorled, 136  
 Bulb, defined, 139  
     tunicated, 139  
     scaly, 139  
 Bur-reed, 409  
 Burseraceæ, 351  
 Butomus, anthers of, 190  
 Buttercup Family, 324  
  
 Cæsalpineæ, 341  
 Cacao Præparatum N. F., 362  
 Cactaceæ, 370  
 Cactus Family, 370  
     grandiflorus, 371  
 Caffaina, 366  
 Caffeine, 84  
     micro-chemic test for, 84  
 Calamus, 301  
 Calamus Draco, 300  
 Calceolaria, 189, 393  
 Calcium oxalate, types of crystals, 86  
     87  
     how formed, 85  
     tests for, 85  
 Calcium pectate, 61  
 Calendula officinalis, 406  
 California Poppy, 332  
 Callicarpa, 395  
 Callistemnon, 172  
 Callitris quadrivalvis, 295  
 Callus, 98  
 Caltrop Family, 348  
 Calumba, 328  
 Calyptra, of moss, 287  
 Calyptrogen, 99, 122  
 Calyx, bilabiate, 184  
     caducous, 184  
     campanulate, 184  
     chorisepalous, 183  
     deciduous, 184  
     defined, 183  
     epigynous, 184  
     gamosepalous, 183, 184

- Calyx, half-superior, 184  
   hypocrateriform, 184  
   hypogynous, 184  
   inferior, 184  
   irregular, 184  
   petaloid, 183  
   perigynous, 184  
   persistent, 184  
   regular, 184  
   rotate, 184  
   superior, 184  
 Cambogia, 366  
 Cammeliaceæ, 366  
 Campanulaceæ, 401  
   placentation in, 197  
 Campanulales, 400  
 Camphora, 332  
 Candytuft, 334  
 Cane sugar, micro-chemic test for,  
   74  
 Canella N. F., 368  
   Winterana, 368  
 Canellaceæ, 368  
 Canna, starch of, 81  
   style of, 198  
 Cannabis, 319  
   sativa, 88, 319  
   var. indica, 319  
 Capitulum, 179  
 Caprifoliaceæ, 399  
 Capsicum, 208  
   annuum, 391  
   frutescens, 391  
 Capsule, 206  
   histology of a, 211  
 Careya, 374  
 Carcerulus, 206  
 Cardamomii Semen, 304  
 Carica Papaya, 369  
 Caricaceæ, 369  
 Carina, 186  
 Carnauba wax, 300  
 Carnoy fluid, 24  
 Carotin, 93  
 Carpel, defined, 195  
 Carpophore, 183, 206  
 Carragheen, 246  
 Carrion fungi, 279  
 Carthamus tinctorius, 407  
 Carum, 377  
   Carvi, 377  
 Caruncle, 214  
 Carya, 316  
 Caryophyllus, 375  
 Caryopsis, 208  
 Cascara Sagrada, 359  
 Cascarilla, 355  
 Cassia acutifolia, 343  
   angustifolia, 343  
   Fistula, 343  
 Cassia buds, 332  
 Castanea, 88, 316, 319  
   dentata, 319  
 Castilloa, 94  
 Cat-tails, 409  
 Cataria N. F., 397  
 Catechu, 344  
 Cathartocarpus fistula, 6, 207, 343  
 Catkin, 179  
 Cattleya, 307  
 Caulicle, 121  
 Caulophyllum, 327  
   thalictroides, 327  
 Caustics, 63  
 Cedrella, 353  
 Celandine, latex of, 94  
 Celastraceæ, 356, 357  
 Celastrus, 356  
 Cell, typical plant, 60, 61  
   as a fundamental unit, 60  
   membranes, 61  
 Cell formation and reproduction, 70  
   resting stage of, 71, 72  
   sap, 61.  
 Cell walls, 96  
   behavior of, to micro-chemic re-  
   agents, 98  
   growth in area and thickness, 97

- Cell walls, various kinds of and behavior of each to micro-chemical reagents, 98
- Celloidin sections, 29
- Cells, epidermal-daughter, 175  
 neighboring, 174  
 of epidermis of onion-bulb scale, 61  
 subsidiary, 174  
 stoma-mother, 175
- Cellulose, 96, 98  
 ferment, 95  
 fungous, 252  
 mucilaginous modification of, 98  
 reserve, 98
- Celsia, 189
- Centaurium, 384
- Centrospermae, 322
- Cephaelis acuminata, 398  
 Ipecacuanha, 398
- Cephalanthus, 398
- Cereus, 370  
 giganteus, 370  
 grandiflorus, 371
- Cerevisiae Fermentum Compressum, 255
- Cetraria islandica, 281, 282  
 Fig. of, 281
- Chalaza, 197
- Chamaelirium luteum, 303
- Chara, 241, 242
- Characeae, 241
- Charales, 241
- Chaulmoogra oil, 368
- Chelidonium, 206, 332  
 majus, 333
- Chemotropism, 63
- Chenopodiaceae, 322
- Chenopodiales, 322
- Chenopodium, 324  
 anthelminticum, 324  
 Fig. of fruit, 208
- Cherry, 209, 338
- Cherry gum, 91
- Cherry laurel, emulsion in leaves of, 96
- Chestnut, 316
- Chicory, 404, 405
- Chimaphila, 379  
 umbellata, 380
- Chinese Galls, 356
- Chionanthus, 381  
 virginiana, 381
- Chionanthus N. F., 381
- Chirata, 384
- Chlamydobacteriaceae, 221
- Chlamydomonas, 232
- Chlamydospores, 267
- Chlorenchyma, 101
- Chlorophyceae, 231
- Chlorophyll, 93
- Chlorophyllin, 93
- Chloroplastids, 70
- Chlor-zinc-iodine, 98
- Choke cherry, 6, 96
- Chondodendron tomentosum, 328
- Chondrus crispus, 246
- Choripetalae, 310
- Chromatin, 71
- Chromatophores, 69
- Chrome-acetic fluids, 24
- Chromic acid, 23
- Chromophyll, 93  
 parenchyma, 101
- Chromoplastids, 70
- Chromogens, 219
- Chromosomes, 73
- Chrysanthemum, corolla of, 187
- Chrysanthemum cinerariifolium, 406  
 Marschallii, 406  
 roseum, 406
- Chrysarobinum, 344
- Chytridiales, 251
- Cichorium, 407  
 Intybus, 407
- Cimicifuga, 325  
 racemosa, 325  
 Fig. of, 326

- Cinchona, 5, 398  
   Calisaya, 398  
   Ledgeriana, 398  
   Rubra, 398  
   succirubra, 398  
 Cinnamomum Burmanii, 332  
   Camphora, 332  
   Cassia, 332  
   Loureirii, 332  
   Saigonicum, 332  
   Zeylanicum, 332  
 Cinquefoil, 338  
 Cistaceæ, 369  
 Citrullus colocynthis, 401  
   vulgaris, 401  
 Citrus, 349  
   Aurantium, 350  
   amara, 350  
   Bergamia, 351  
   sinensis, 350  
   medica Limomum, 350  
     acida, 351  
 Cladonia, 281  
 Clarodendron, 395  
 Class, 2  
 Classification, principles of, 2, 3  
 Clavaria flava, Fig. of, 272  
 Clavariales, 273  
 Claviceps purpurea, life history of,  
   265, 266, 267  
 Clematis, 207, 324  
 Clitandra, 94  
 Close fertilization, prevention of, 199  
 Clove, 375  
 Clove Bark, 332  
 Club Mosses, 288  
 Coalescence, 183  
 Coca, 348  
   leaf epidermis, 174, 175  
 Coca Family, 347  
 Cocaine, 84, 348  
 Coccaceæ, 220  
 Coccoloba platyclada, 321  
   uvifera, 321  
 Cocculus, 328  
 Cocillana, 354  
 Coconut oil, 300  
   fruit, 210  
 Cocos nucifera, 75, 300  
 Cœnocyte, 241  
 Coffea arabica, 398  
   libercia, 398  
 Coffea Tosta N. F., 398  
 Coffee, 398  
 Cohesion, 183  
 Cola Family, 361  
 Cola acuminata, 362  
 Colchici Cormus, 303  
   Semen, 303  
 Colchicum, 302  
 Colchicum autumnale, 84, 303  
 Colchicine, micro-chemic test for, 84  
 Colocynthis, 400  
 Colocynthis, 401  
 Collenchyma, 102, 103  
 Collinsonia, 5, 397  
 Columbine, 325  
 Columella, 249  
 Columnar crystals, 86  
 Coma, 214  
 Comatricha, 230  
 Combretaceæ, 375  
 Combretum, 376  
 Combretum sundaicum, 376  
 Comfrey, 390  
 Commiphora, 352  
 Commiphora myrrha, branch of, 353  
 Companion cells, 112, 113  
 Compositæ, 402  
   inulin in, 82  
 Compressed yeast, 255  
 Comptonia, 314  
 Comptonia asplenifolia, epidermis of  
   leaf, 106  
   photomicrograph of long-section  
   through staminate catkin of,  
   178  
 Conceptacles of Fucus, 244, 245

- Conducting parenchyma, 101  
 Conducting tissues, 120  
 Condurango, 386  
 Cone, defined, 211  
     figs. of, 47, 49  
 Confervales, 234  
 Conidia, 259  
 Conidiospores, 259  
 Coniferæ, 294  
 Coniferin, micro-chémic test for, 83  
 Coniferales, 294  
 Conifer, 293  
 Conium N. F., 377  
 Conium maculatum, 377  
 Conjugales, 236  
 Conjugation, 71, 237  
 Connation, 183  
 Connective, 188  
 Contortæ, 381  
 Convallaria majalis, 303  
 Convallariæ Radix, 303  
     Flores, 303  
 Convolvaceæ, 386  
 Convolvulus Scammonia, 387, 388  
 Copaiba, 344  
 Copernicia cerifera, 300  
 Copper acetate test for tannins, 88  
     test for resins, 93  
 Coptis, N. F., 327  
     trifoliata, 327  
 Coral fungi, 273  
 Corallin-soda solution, 98  
 Coriandrum, 377  
 Cork, defined, 110  
     microchemic tests for, 110  
 Cork cambium, origin in roots, 126  
     origin in stems, 143  
 Cork formation in roots, 126  
     in stems, 143  
 Corm, 139  
 Corn, inflorescence of, 298  
     smut, 267, 268, 269  
     starch, 79  
     stem, figs. of sections of, 152, 153
- Cornaceæ, 378  
 Cornus N. F., 378  
 Cornus canadensis, 378  
     florida, 378  
     sanguinea, 378  
 Corolla, defined, 185  
     apopetalous, 185  
     bilabiate, 186  
     campanulate, 187, 188  
     carophyllaceous, 188  
     choripetalous, 185  
     crateriform, 186  
     cruciform, 186, 187  
     forms of, 187  
 Corolla, gamopetalous, 186  
     hypocrateriform, 186  
     labiate, 186, 187  
     ligulate, 186, 187  
     infundibuliform, 187, 188  
     papilionaceous, 186, 187  
     persoate, 186  
     polypetalous, 186  
     ringent, 186, 187  
     rotate, 186, 187  
     urceolate, 187, 188  
 Correa grandiflora, 350  
 Corrosive sublimate, 24  
 Corydalis, 334  
 Corymb, 179  
 Corynebacterium, 221  
 Coto, 332  
 Cotyledons, 121, 156  
 Cremocarp, 206, 207  
 Crenothrix, 222  
 Cribiform tissue, 112  
 Crocus sativus, 304  
 Croton Eluteria, 355  
     tiglium, 355  
 Cruciferæ, 334  
 Crude sap, 39  
 Crystal fibers, 86, 87  
 Crystal sand, 86, 87  
 Cubeba, 311  
 Cucumber, 400, 401

- Cucurbita Pepo, 401  
 Cucurbitaceæ, 400  
 Cudbear, 282  
 Culm, 138  
 Cuoxam, 98  
 Cup Fungi, 256  
 Cuphea, 371, 372  
 Cupules, 283  
 Cupuliferæ, 316  
 Curcuma N. F., 304  
 Curcuma longa, 304  
     Zedoaria, 304  
 Currant, 208, 209  
 Cutin, 97  
 Cyanophyceæ, 227  
 Cycas revoluta, 293  
 Cydonia vulgaris, 341  
 Cydonium, 341  
 Cyme, 179  
     Scorpioid, 180  
 Cynoglossum officinale, 390  
 Cypress, 410  
 Cyripediæ, 307  
 Cyripedium N. F., 308  
     hirsutum, 308  
     parviflorum, 308  
 Cystolith, 87  
     hair, 88  
 Cytase, 95  
 Cytisus scoparius, 344  
 Cytology, 1, 60  
 Cytoplasm, 60, 68  
 Cytoplasmic caps, 73  
  
 d-mannose, 74  
 Dacromyces deliquescens, 272  
 Dacromycetales, 272  
 Dahlia, 85, 404  
 Daisy, 404  
 Daisy Family, 402  
 Damiana, 369  
 Dammar, 295  
 Dandelion, 404, 406  
  
 Daphne Gnidium, 371  
     Laureola, 371  
     Mezereum, 371  
         fig. of, 370  
 Date Palm, 299  
 Datura Stramonium, 391  
     Tatula, 391  
 Decadon, 371  
 Dehiscence, apical porous,  
     in anthers, 191  
     diagrams of valvular in fruits,  
         203  
     in fruits, 202, 204  
     longitudinal anther, 191  
     transverse anther, 192  
     valvular, 191  
 Delafield's hæmatoxylin, 29  
 Delphinium, 325  
     Ajacis, 327  
     consolida, 327  
     spur of, 184  
     Staphisagria, 325  
 Delphinium N. F., 325  
 Dermatogen, 100, 122  
 Desilicification of woody sections, 30  
 Desmidaceæ, 236  
 Determinate inflorescences, 179  
     solitary, 179  
 Deutzia, trichomes on leaves of, 107,  
     109  
 Dextrin, 81, 82  
     white, 81  
     yellow, 81  
 Dextrose, 74  
 Dianthera, 395  
 Diastase, 95  
 Diatoma vulgare, 238  
 Diatomaceæ, 238  
 Diatomaceous Earth, 239  
 Diatomales, 238  
 Diatoms, 91, 238, 239, 240, 241  
 Dicentra canadensis, 334  
     cucullaria, 334  
 Dicotyl Plant, morphology of type, 309



- Dicotyl Seed, gross structure of, 217  
 stems, 140, 147
- Dicotyledoneæ, characteristics of, 308,  
 309
- Dictyophora duplicata, 279
- Dicypellium carophyllatum, 332
- Diervilla, 400
- Differences between Gymnosperms  
 and Angiosperms, 58, 59  
 roots and stems, 123  
 histological, between leaves of  
 Dicotyls and Monocotyls,  
 176
- Digitalis, 392  
 purpurea, 393  
 trichomes of, 107  
 var. *gloxinæflora*, 394
- Digitoxin, micro-chemic test for, 83
- Dionæa muscipula, 65, 67, 335
- Dioscorea, 5, 303  
 villosa, 303
- Dioscoreaceæ, 303
- Diosma, 349, 350
- Dittany, 350
- Division, 2
- Dodder, 124, 137
- Dog Bane Family, 384
- Dogwood Family, 378
- Dog's Tooth Violet, life history of, 53,  
 58
- Dorema Ammoniacum, 378
- Dorsoventral leaf blades, 169
- Dracena Draco, 301
- Dragon's Blood, 300
- Drimys Winteri, 324
- Drosera, 335  
 effect of mechanical stimulus in,  
 67  
 longifolia, 336  
 intermedia, 336  
 rotundifolia, 336
- Droseraceæ, 335
- Drupe, 209  
 fig. of, 210
- Dryopteris Filix-mas, alternation of  
 generations in, 44  
 comparative physiology of root,  
 stem and leaf, 39, 40  
 fig. of, 34  
 gross structure of stem, 33  
 sori and sporangia, 40  
 growth of seedling into mature  
 sporophyte, 44  
 histology of growing apex, 36  
 lamina, 38  
 mature root, 36  
 stem, 33  
 root apex, 37  
 sori and sporangia, 40  
 stipe, 37  
 history of gametophyte genera-  
 tion, 41, 45  
 sporophyte generation, 33, 41
- Dryopteris Filix-mas, origin of new  
 sporophyte or diploid plant  
 from fertilized egg, 44  
 vascular bundles of, 35, 292
- Dryopteris marginalis (*frontispiece*),  
 292
- Duboisia myoporoides, 391
- Dulcamara, 391
- Duramen, 152
- Ear fungi, 271
- Earth Stars, 279
- Earth Tongues, 265
- Ebenales, 380
- Ecballium Elaterium, 401
- Echinacea, 406
- Echinocactus, 370
- Echinocereus, 371
- Echium, 389
- Ecology, 1, 408
- Economic Botany, 2
- Ectocarpus siliculosus, 242, 243
- Ectoplasm, 39
- Egg Plant, 391

- Ehrlich's Anilin Water Gentian Violet, 226  
*Elæis guineensis*, 300  
*Elastica*, 355  
*Elaterinum*, 401  
*Elettaria Cardamomum*, 304  
 Elm Family, 319  
 Embryo, 121  
 Embryo-sac, 49, 55, 197  
     maturation of, 55  
 Emulsin, 96  
 Endocarp, 202  
 Endodermis, 109, 110  
 Endospores, 220, 221  
 Endosporium, 41  
 Endothecium, 191  
*Entada scandens*, 207  
 Enzyme, 94  
 Enzymes, 94, 95  
     classification of, 95, 96  
 Epicalyx, 185  
 Epicarp, 202  
 Epidermal, outgrowths, 108-109  
     papillæ, 108  
     scales, 109  
 Epidermis, 106  
 Epiphegus, 5  
 Epithelium, 120  
 Equatorial plate, 73  
*Equisetineæ*, 289  
*Equisetum*, 290  
     arvense, 291  
 Ergot fungus, 265  
*Erica*, 379  
*Ericaceæ*, 379  
*Ericales*, 379  
*Erigeron canadensis*, 407  
*Eriodictyon*, 5  
*Eriodictyon californicum*, 388  
     trichomes of, 107  
*Eriogonum*, 321  
*Erythraea Centaurium*, 384  
*Erythronium Americanum*, life history  
     of, 53-58  
*Erythroxyloaceæ*, 347  
*Erythroxyton Coca*, 348  
*Eschscholtzia*, 332  
 Etereo, 210  
 Etiolin, 93  
 Etiology, 2  
*Eucalyptol*, 375  
*Eucalyptus*, 374, 375  
     globulus, 373, 375  
     lamina, 172  
     photomicrograph of trans. sect.  
         leaf-blade, 173  
     Kino, 375  
     rostrata, 375  
*Endorina*, 232  
*Eugenia aromatica*, 374, 375  
*Eugenol*, 375  
*Euonymus*, 356  
     Americanus, 356  
     atropurpureus, 357  
     Europæus, 356  
*Euonymus N. F.*, 357  
     Fig. of flowering and fruiting  
         branch, 357  
     Fig. of bark in cross-section, 358  
*Eupatorium*, 406  
     perfoliatum, 406  
*Euphorbia*, 355  
     Pilulifera, 355  
*Euphorbiaceæ*, 355  
*Euphrasia*, 392  
*Eurotium*, 260  
*Exoascus*, 251  
*Exobasidiales*, 273  
*Exogonium Purga*, 388  
*Exosporium*, 41  
*Exothecium*, 191  
*Fabaceæ*, 341  
*Fagaceæ*, 316  
*Fagales*, 316  
*Fagot Cassia*, 332  
*Fagus grandifolia*, 316  
 Families, naming of, 7

- Family, 2  
 Farfara, N. F., 406  
 Fats, 91  
 Fatsia horrida, 376  
 Ferment, 94  
 Ferments, 95  
     carbohydrate, 95  
     fat and oil, 96  
     glucoside, 96  
     proteinaceous, 96  
 Fern, antheridium, 43  
     apical cell, 36, 37  
     archegonium, 42, 43  
     foot of, 44  
     prothallium, 42  
     sperms of, 43  
 Ferns, 290  
     true, 292  
     water, 292, 409  
 Fern Palms, 293  
 Fertilization, defined, 71  
     in angiosperms, 200, 201  
     cross, 199  
     self, 199  
 Ferula, Asafœtida, 377  
     fœtida, 377  
     galbaniflua, 378  
     Sumbul, 377  
 Fibro-vascular bundles, definition, 117  
     bicollateral, 117, 118  
     closed collateral, 117  
     concentric, 118  
     diagrams of, 117  
     open, 117  
     radial, 118  
 Ficus N. F., 319  
     Carica, 319  
     elastica, 94, 171  
 Figwort Family, 392  
 Filament, 188  
     gross structure of, 190  
     histology of, 190  
 Filicales, 292  
 Filicineæ, 290  
 Fission, 70  
 Fistulina, 274  
 Fixation, 23  
 Fixing agents, 23-25  
 Fixed oils, 91  
     tests for, 91  
 Flax, 347  
     bast fibers of, 105  
 Flax Family, 346  
 Flemming fluids, 24, 25  
 Floral diagrams, 251  
 Flower, complete, 181  
     diandrous, 188  
     dichlamydeous, 183  
     double, 182  
     essential organs of, 181  
     hermaphrodite, 181  
     hexandrous, 188  
     imperfect, 182  
     liliaceous, 186  
     monochlamydeous, 183  
     neutral, 182  
     orchidaceous, 186  
     perfect, 181  
     pentandrous, 188  
     pistillate, 182  
     polyandrous, 188  
     regular, 182  
     stalk, 178  
     staminate, 182  
     symmetrical, 182  
 Fœniculum, histology of mericarp, 212  
     vulgate, 377  
 Fœnum græcum, 344  
 Foliage leaves, 156  
 Follicle, 206. (See pod.)  
 Foot, 291  
 Fomes, 274  
 Forestry, 2  
 Forsythia, 381  
 Fothergilla, 337  
 Fovilla, 55  
 Foxglove, 392  
 Fragaria, 185

- Frangula, 359  
 Fraxinus, 381  
     *Americana*, 381  
     *Ornus*, 74, 381  
 Free cell formation, 71  
 Frond, 33, 290  
 Fructose, 74  
 Fruit, classification of, 204  
 Fruit, definition, 202  
     structure, 202-213  
 Fruits, achenial, 204, 207, 208  
     aggregate, 204, 210  
     baccate, 204, 208, 209  
     capsular, 204, 205  
     drupaceous, 204, 205  
     multiple, 204, 210  
     schizocarpic, 204, 206, 207  
     simple, 204  
 Fucus vesiculosus, description  
     of, 244, 246  
     Figs. of, 243, 244, 245  
 Fumariaceæ, 334  
 Fumitory Family, 334  
 Fundamental considerations, 1-32  
     tissue, 101  
 Fungi, 247  
 Fungi Imperfecti, 280  
 Funiculus, 196, 214  
 Funtumia africana, 94  
     *elastica*, 94  
  
 Galanga, 304  
 Galbalus, defined, 211  
     fig. of, 210  
 Galbanum, 378  
 Galea, 184  
 Galega N. F., 344  
     *officinalis*, 344  
 Galium, 398  
 Galla, 319  
 Galls, Chinese, 356  
     Japanese, 356  
 Galvanotropism, 66  
 Gambir, 398  
  
 Gamboge family, 366  
 Gamete, 71, 237  
 Gametophyte, generation of Male  
     Fern, 44  
 Gamopetalæ, 378  
 Garcinia Hanburyi, 366, 367  
 Gasteromycetes, 278  
 Gaultherase, 96  
 Gaultheria, 380  
     *procumbens*, 96, 380  
 Gaultherin, 96  
 Gaylussacia, 379  
 Geaster, 278  
 Gelidium, 246  
 Gelsemium, 382, 384  
     *sempervirens*, 384  
     stem, 145  
 Gemmæ, 283  
 Gemmation, 70  
 Genetics, defined, 1  
 Gentiana, 384  
     *acaulis*, 384  
     *lutea*, 383, 384  
     *verna*, 384  
 Gentianaceæ, 384  
 Gentianales, 381  
 Genus, 2  
 Geological Botany, defined, 2  
 Geotropism, 65  
     lateral, 66  
 Geraniales, 344  
 Geranium, 344  
     *maculatum*, 346  
 Geranium Family, 344  
 Gerardia, 124, 392  
 Germination, 216  
 Gesneria, placentation in, 197  
 Geum, 183, 185  
 Gigartina mamilliosa, 246  
 Gills of mushrooms, 274, 275  
 Ginger, absence of lignin in scleren-  
     chyme fibers of, 103  
     Family, 304  
     Fig. of plant, 306

- Ginkgoales, 4  
 Ginseng, 376  
 Ginseng Family, 376  
 Glands, internal, 119  
 Glans, 208  
 Gleba, 278  
 Glæocapsa, 227, 228  
 Gliadins, 89  
 Globoid, 90  
 Globulins, 89  
 Gloiopeltis, 246  
 Glomerule, 180  
 Gloxinia, 197  
 Gluco-alkaloids, 85  
 Glucosides, characteristics of, 83  
 Glutelins, 89  
 Glycerin-Gelatin, 22  
 Glycine hispida, 344  
 Glycyrrhiza, 343  
     glabra, 343  
     glandulifera, 343  
 Gnaphalium polycephalum, 407  
 Gnetales, 4  
 Gnetums, 293  
 Gonophore, 183  
 Gooseberry, 209  
 Goosefoot Family, 322  
 Goosypii Cortex N. F., 365  
 Gossypium, 363  
     arboreum, 365  
     Barbadense, 365  
     herbaceum, 364, 365  
     hirsutum, 365  
 Gossypium Purificatum, 365  
 Gourd, 209  
 Gourd Family, 400  
 Gracilaria lichenoides, 246  
 Grain, 208  
 Graminales, 298  
 Gramineæ, 298  
     silica in, 88  
 Gram's method, 225  
 Granati Fructus Cortex, 372  
 Granatum, 372  
 Grape, 208  
 Grape Family, 359  
 Grape Fruit, 209  
 Grass Family, 247  
 Greenbrier, histology of stem, 153,  
     154  
 Green felt, 91, 241  
 Grindelia camporum, 406  
     cuneifolia, 406  
     squarrosa, 406  
 Gross anatomy, defined, 1  
 Ground Ivy, 395  
 Gruinales, 344  
 Guaiaci Lignum, 349  
 Guaiacum, 348  
 Guaiacum officinale, 349  
     sanctum, 349  
 Guarana, 358  
 Guard cells, 173  
 Guarea Rusbyi, 354  
 Gum resins, 92  
 Gums, 90, 91  
 Gutta Percha, 380  
 Guttiferæ, 366  
 Gynœcium, 195  
     apocarpous, 196  
     syncarpous, 196  
 Gynophore, 183  
 Gymnosperm, life history of a, 45-52  
 Gymnospermæ, 292  
 Gymnosperms, 292  
     differences from angiosperms, 58  
 Haas and Hill, 95  
 Habitat, defined, 1  
 Hæmatoxylon, 343  
     campechianum, 343  
 Hagenia abyssinica, 338  
 Hairs, aggregate, 107  
     barbed, 108, 109  
     branched, 107  
     candelabra shaped, 109  
     clavate, 107, 109  
     climbing, 108

- Hairs, glandular, 107  
     hooked, 108, 109  
     multicellular, 109  
     non-glandular, 109  
     root, 121, 122  
     stellate, 107, 109  
     stinging, 108  
     tufted, 109  
     unicellular, 107  
     uniseriate, 109
- Halophytes, 410
- Haloxylon, 323
- Hamamelidaceæ, 337
- Hamamelidis Folia, 338
- Hamamelis virginiana, 338
- Hancornia, 94
- Hanstein, 99
- Harebell, corolla of, 187
- Hard Bast, 144
- Harshberger, 264
- Haustoria, 123, 247
- Hawthorn, 338
- Head, defined, 179
- Heath Family, 379
- Hedeoma, 397
- Hedeoma pulegioides, 397
- Hedera Helix, 376
- Helianthemum, 369, 370  
     canadense, 370
- Helianthus tuberosus, 404
- Heliotropeæ, 388, 390
- Heliotropism, 64
- Helleborus niger, 327
- Helonias, 303
- Helophytes, 409
- Helvellales, 264
- Henbane, 391
- Henna, 372
- Hepaticæ, 283
- Hepburn, 94
- Herb, defined, 139
- Herba Majoranæ, 397
- Hertwig, 64
- Hesperidin, micro-chemic test for, 82.
- Hesperidium, 209
- Heterocysts, 229
- Hevea, 94
- Hevea braziliensis, 355
- Hibiscus Syriacus, 363
- Hilum,  
     of ovule, 19  
     of seed, 214  
     of starch grain, 76
- Hip, 207
- Histology, defined, 1  
     of Aconitum, 132  
     of a dicotyl root, 127, 131  
     of annual dicotyl stem, 140  
     of anther, 190  
     of Aristolochia Siphon stem, 140,  
         144  
     of bark, 149  
     of California Privet root, 127,  
         131  
     of Cascara Sagrada, 149
- Histology of dicotyl tuberous root, 132
- of dicotyl roots, of primary  
     growth, 125, 126  
     of secondary growth, 126, 127
- of dicotyl stems, 140, 146
- of fern lamina, 38, 39
- root, 36, 37
- sori and sporangia, 40, 41
- stem, 33, 36
- stipe, 37
- of filament, 190
- of fruits, 211, 213
- of Greenbrier stem, 153, 154
- of herbaceous monocotyl stem, 152
- of leaves, 167, 176
- of mericarp, 212
- of monocotyl stems, herbaceous,  
     152  
     woody, 153, 154
- of perennial dicotyl stem, 143, 144
- of seeds, 215, 218
- of Vanilla capsule, 211
- Holdfast, 244

- Honduras Sarsaparilla, histology of  
     root, 124  
 Honey dew, 265  
 Honeysuckle Family, 399  
     fruit, 209  
 Hordeum sativum, 299  
 Horsetails, 289  
 Host, 247  
 Hounds' tongue, 390  
 Humulus, 319  
     glandular trichomes of, 107, 109  
 Humulus lupulus, 109, 319  
 Hura crepitans, 206  
 Huxley, 62  
 Hyacinth, 302  
 Hybrid, 2  
 Hydnaceæ, 274  
 Hydnum, 274  
 Hydrangea, 336, 337  
     arborescens, 337  
 Hydrastis canadensis, 325  
 Hydrophytes, 408  
 Hydrophyllaceæ, 388  
 Hydropterales, 292  
 Hydrotropism, 64  
 Hymenium, 272, 275  
 Hymenomycetes, 272  
 Hyoscyamus, 391  
     muticus trichome, 107  
     niger, 391  
 Hypericaceæ, 367  
 Hypericum, 367, 368  
     perforatum, 368  
 Hypha, 247  
 Hyphæ, aerial, 248  
     stoloniferous, 248  
     submerged, 248  
 Hyssopus officinalis, 397  
  
 Ignatia, 384  
 Illicium verum, 324  
 Imbedding, celloidin, 28, 29  
     paraffine, 23, 26  
 Impatiens, 5  
  
 Indigenous, defined, 1  
 Indigo, 344  
 Indigofera tinctoria, 344  
 Indirect nuclear division, 71, 74  
 Indusium, 290  
 Inflorescence, defined, 177  
     ascending, 177  
     centrifugal, 177  
     centripetal, 177  
     cymose, 177  
     determinate, 177  
     descending, 177  
     indeterminate, 177  
     mixed, 177  
 Inflorescences, of Pine, 294  
     of Zea Mays, 298  
 Imperatoria Ostruthium, 378  
 Indehiscent fruit, 203  
 Indeterminate inflorescence, solitary.  
     178  
 Indian Corn, histology of seed, 215  
 Indian Turnip, 301  
 Indirect nuclear division, 71  
 Integuments of angiospermous ovule,  
     196  
 Intercellular-air-spaces, lysigenous. 119  
     schizogenous, 119  
 Internal glands, 199  
     phloem, 146  
 Internode, defined, 137  
 Intussusception, 62  
 Inula N. F., 406  
 Inula Helenium, 406  
 Inulase, 95  
 Inulin, 82  
 Invertase, 75, 95  
 Involucre, 178  
 Ipecacuanha, 398  
 Ipomœa, 388  
     orizabensis, 388  
     pandurata, 388  
     simulans, 388  
 Iridaceæ, 304  
 Iris, 304, 309

- Iris, concentric bundle from rhizome  
     of, 116  
     *florentina*, 304  
     *germanica*, 304  
     *pallida*, 304  
     *versicolor*, 304  
 Irish Broom, corolla of, 187  
     Dulse, 247  
     Moss, 246  
 Irritability, 62  
 Irritable reactions, 62, 68  
 Isœtaceæ, 288  
 Isœtes, 288  
  
 Jalapa, 388  
     Male, 388  
     Tampico, 388  
     Wild, 388  
 Janczewski, 99  
 Japanese Galls, 356  
 Jateorhiza palmata, 328  
 Jeffersonia, 5  
 Jerusalem Artichoke, 351  
 Jungermanniales, 283  
 Juglandaceæ, 315  
 Juglandales, 315  
*Juglans* N. F., 316  
     *cinerea*, 316  
 Juniperus, 294  
     *communis*, 295  
     *Oxycedrus*, 295  
     *Sabina*, 295  
     *Virginiana*, 295  
 Juniperus N. F., 295  
 Jute, bast fiber of, 105  
  
 Kalmia, 380  
 Kamala, 107, 355  
 Karyokinesis, 71, 74  
 Kava, 311  
 Kieselguhr, 239  
 Kino, 344  
 Kochia, 323  
*Kœnigia*, 321  
  
 Kola, 362  
*Krameria argentea*, 344  
     *Ixina*, 344  
     *triandra*, 344  
 Kühne, 66  
  
 Labellum, 186  
 Labiatæ, 395  
 Labrador tea, 410  
 Lachnea, 256  
     Fig. of, 257  
 Lactase, 95  
 Lactuca, 94  
     *virosa*, 94, 406  
 Lactucarium, 406  
 Lamellæ, of starch grain, 76  
 Lamiaceæ, 395  
 Lamina, defined, 169  
 Lamina, mode of development of, 169  
 Landolphia, 94  
 Lappa, 406  
*Larix Europæa*, 295  
 Larkspur, 324  
     corolla of, 187  
 Lateral rootlets, 123, 128  
 Latex, 94, 112  
     cells, 110  
     micro-chemic test for, 94  
 Laticiferous tissue, 110  
     vessels, 111  
 Lauraceæ, 330  
*Laurus*, 332  
*Lavendula vera*, 397  
     *spica*, 397  
*Lawsonia inermis*, 372  
 Leaf, color, 166  
     complete, 158  
     definition of, 155  
     exstipulate, 159  
     functions, 155  
     petaloid, 166  
     petiolate, 159  
     sessile, 159  
     stipulate, 159



- Leaf apex, 163  
   acuminate, 163  
   acute, 163  
   aristate, 163  
   cuspidate, 163  
   emarginate, 163  
   mucronate, 163  
   obcordate, 163  
   obtuse, 163  
   retuse, 163  
   truncate, 163  
 arrangement, 156  
   alternate, 157  
   decussate, 157  
   fascicled, 157  
   opposite, 157  
   verticillate, 157  
 base, 163  
   auriculate, 163  
   cordate, 163  
   cuneate, 163  
 Leaf base, hastate, 163  
   reniform, 163  
   sagittate, 163  
 duration, 167  
   caducous, 167  
   deciduous, 167  
   evergreen, 167  
   persistent, 167  
 insertion, 159, 161  
   amplexicaul, 161  
   cauline, 159  
   clasping, 161  
   connate-perfoliate, 161  
   equitant, 161  
   perfoliate, 159  
   radical, 159  
   ramal, 159  
 rank, 157  
 margin, 163, 165  
   crenate, 163  
   cleft, 165  
   dentate, 163  
   divided, 165  
 Leaf base, margin, entire, 163  
   incised, 165  
   lobed, 165  
   parted, 165  
   repand, 165  
   runcinate, 165  
   serrate, 163  
   sinuate, 165  
 outline, 161  
   acerose, 163  
   acicular, 163  
   cuneate, 161  
   deltoid, 163  
   elliptical, 161  
   ensiform, 163  
   falcate, 163  
   filiform, 161  
   inequilateral, 161  
   linear, 161  
   lanceolate, 161  
   oblong, 161  
   oblanceolate, 161  
   orbicular, 161  
   ovate, 161  
   peltate, 161  
   spatulate, 163  
 surface, 166  
   glabrous, 166  
   glaucous, 166  
   hispid, 166  
   pubescent, 166  
   pellucid-punctate, 166  
   rugose, 166  
   scabrous, 166  
   sericious, 166  
   spinose, 166  
   tomentose, 166  
   villose, 166  
   verrucose, 166  
 texture, 166  
   coriaceous, 166  
   membranous, 166  
   succulent, 166  
 venation, 159

- Leaf venation, anastomosing, 159  
 furchate, 159  
 palmate, 159  
 parallel, 159  
 pinni, 159  
 reticulate, 159
- Leaves, bifacial, 172, 173  
 binate, 166  
 bipinnate, 123, 126  
 biternate, 166  
 bract, 156  
 bracteolar, 155  
 centric, 172  
 compound, 161  
 palmately, 165  
 pinnately, 165  
 convergent, 169, 172  
 decomposed, 166  
 development of lamina of, 169  
 dorsoventral, 169  
 hydrophytic, 169, 172  
 mesophytic, 169, 171  
 umbrophytic, 169, 170  
 xerophytic, 169, 171  
 foliage, 156
- Leaves, imparipinnate, 165  
 interruptedly pinnate, 165  
 lyrate, 165  
 origin and development of,  
 156  
 palmate, 165  
 paripinnate, 165  
 pinnate, 165  
 primordial, 156  
 scale, 156  
 simple, 161  
 stomata of, 173  
 ternate, 166  
 trifoliate, 166  
 types of Angiospermous, 155  
 xerophytic, 169, 172
- Lecanora, 281  
 Lechea, 369  
 Legume, 206
- Leguminosæ, 341  
 placentation in, 197  
 root tubercles of, 132, 133
- Lemon, fruit of, 209  
 Lenticels, 146  
 Leptandra, 393  
 Leptome, 112  
 Leucoplastids, 69, 76  
 Levisticum, 378  
 officinale, 378
- Levulose, 74  
 Lichens, 280, 282  
 Licmophora, 239  
 Life history, of an angiosperm, 53, 58  
 of aspidium, 33, 45  
 of black mold, 248, 250  
 of claviceps purpurea, 265, 267  
 of fern, 33, 45  
 of gymnosperm, 45, 53  
 of moss, 286, 287  
 of mushrooms, 274, 278  
 of rust, 269, 271  
 of smut, 267
- Lignin, 97  
 Lignocellulose, 98  
 Ligule, 168  
 Lilac, 381  
 Liliaceæ, 301, 303  
 Liliales, 301  
 Lilium, 301  
 Lily Family, 301  
 Lima bean, histology of, 217, 218  
 Limb, 184  
 Limonis Cortex, 350  
 Linaceæ, 346  
 Linaria, 189, 392, 393  
 corolla of, 187  
 Linden Family, 363  
 stem, 147  
 Linin, 71  
 Linnæus, 4  
 Linum, 347  
 usitatissimum, 347  
 Lipase, 96

- Lippia lanceolata*, 395  
*Liquidambar orientalis*, 338  
     Fig. of, 337  
 Litmus, 282  
 Liverworts, 283  
*Lobelia inflata*, 402  
 Lobeliaceæ, 402  
 Loganiaceæ, 382  
 Loment, 207  
 Lomentum, 207  
*Lonicera*, 399  
*Lunaria*, 184  
*Lunularia*, Fig. of, 282  
*Lupulinum*, 319  
*Lychnis*, 183  
 Lycoperdales, 278  
*Lycoperdon*, 278  
 Lycopodiaceæ, 288  
*Lycopodium*, 5  
*Lycopodium clavatum*, 288  
 Lythraceæ, 371  
  
 Mace, 82  
*Macis*, 330  
*Macrocystis*, 242  
 Macromorphology, 1  
 Madder family, 398  
 Magnolia family, 324  
 Magnoliaceæ, 324  
 Mahogany Family, 352  
 Making of sections, 15  
 Male Fern, 33, 44  
 Male Jalap, 388  
*Mallotus philippinensis*, 355  
 Mallow Family, 363  
 Maltase, 95  
 Maltose, 75  
 Maltum, 299  
*Malva Folia* N. F., 365  
*Malva rotundifolia*, 363, 365  
     *sylvestris*, 365  
 Malvaceæ, 363  
     anthers of, 191  
 Malvales, 361  
  
*Mamillaria*, 371  
*Manaca*, 391  
 Mangels, 323  
 Mangroves, 410  
*Manihot*, 94, 355  
     *utilissima*, 81, 96, 355  
 Manna, 381  
 Maple, 4, 207  
 Maple Family, 358  
*Maranta arundinacea*, 79  
     starch, 79  
*Marchantia*, 283  
 Marchantiales, 283  
*Marrubium*, 5  
*Marrubium vulgare*, 109, 397  
*Marsdenia Condurango*, 386  
 Marsh, 409  
 Mastiche, 304  
 Matico, 311  
*Matricaria*, 406  
     *Chamomilla*, 405, 406  
 Maturation of pollen grain in Angio-  
     sperms, generally, 200  
     in *Erythronium*, 55  
     of embryo sac and formation of  
     female gametophyte, 200  
 Maw seed, 333  
 May Apple, calyx of, 184  
 Mayer's albumin fixative, 27  
 Mechanical tissues, 120  
 Medullary rays, 116  
*Megaceros*, 283  
*Megasorus*, 213  
 Megaspore, 49, 55, 197  
 Megasporophyll, defined, 195  
*Melaleuca*, 5  
*Melaeluca Leucadendron*, 375  
*Melia*, 353  
 Meliaceæ, 352  
 Melibiose, 75  
*Melilotus*, 344  
     *officinalis*, 344  
*Melissa officinalis*, 397  
*Melochia*, 361

- Melon tree, 369  
 Membrane crystals, 87  
 Menispermaceæ, 327  
 Menispermum, 328  
   canadense, 328  
 Mentha piperita, 397  
   Fig. of glandular trichomes, 107  
   spicata, 397  
   viridis, 397  
 Menyanthes trifoliata, 384  
 Mericarp, 206  
   histology of a, 212  
 Meristem, 100  
 Merulius, 274  
 Mesocarp, 202  
 Mesophytes, 411  
 Metabolism, 62  
 Metachlamydeæ, 378  
 Method for mounting and staining  
   bacteria, 224, 225  
   for preparation of Canada balsam  
   mount, 21  
   for the preparation of a glycerin-  
   gelatin mount, 22, 23  
   for fixing, dehydrating, hardening  
   and imbedding in paraffine,  
   23, 24, 25, 26  
   for sectioning and mounting ma-  
   terial imbedded in paraffine,  
   26, 27  
   for imbedding in celloidin, 28, 29  
   for sectioning celloidin material,  
   29  
   for staining and mounting cel-  
   loidin sections, 29, 30  
   of examining reserve starches, 77  
   for staining and mounting par-  
   affine material, affixed to  
   slide, 27, 28  
   Gram's, 225  
 Methylene Blue, 91, 98  
   Löffler's, 226  
 Methylo Salicylas, 316, 380  
 Mexican Grass, 75, 267  
 Mezereum, 371  
 Micrandra, 355  
 Micrococci, types of, 220  
 Micrococcus catarrhalis, 224  
   gonorrhœæ, 224  
   melitensis, 224  
   meningitidis, 224  
 Micro-crystals, 86, 87  
 Micrometer, ocular, 31  
   stage, 31  
 Micrometry, 31  
 Micromorphology, 1  
 Micron, 31  
 Micropyle, 197  
 Microscope, binocular, 12  
   care of, 14  
   compound, 9, 14  
   defined, 7  
   dissecting, 8  
   Figs. of, 8, 10, 11, 12  
   lamp, 12  
   rules for care of, 14  
   simple, 7  
 Microscopic measurement, 31, 32  
 Microsorium, 188, 190  
 Microsporangia, 190  
 Microspore, 193  
 Microsporophylls, 188  
 Microspira, 221  
 Microtomes, 16, 20  
   hand, 16, 17  
   rotary, 18, 19, 20  
   sliding, 17, 18  
 Middle lamella, 61  
 Milkweed Family, 386  
 Milkwort Family, 354  
 Mimosa, 66, 341  
   Spegazzini, 66, 67, 68  
   thigmotropic reactions in, 68  
 Mimoseæ, 341  
 Mint Family, 395  
 Mistletoe, 101, 124  
 Mitchella, 398  
 Mitella, 336

- Mitosis, 71, 74  
 Mold, black, 248  
     blue, 256  
     bread, 248  
     green, 256  
 Momordica Balsamina, 401  
 Monarda, 396  
     punctata, 397  
 Monkshood, 324  
 Monoclinic prisms, 86  
 Monocotyledon, morphology of typical  
     plants of, 296  
 Monocotyledoneæ, 296  
 Monotropa, 379  
     uniflora, 379  
 Moonseed Family, 327  
 Moraceæ, 319  
 Morchella esculenta, 265  
     Fig. of, 264  
 Morels, 265  
 Morning Glory Family, 386  
 Morphology, defined, 1  
 Mosses, 284, 287  
 Motherwort, 397  
 Mountain Ash, 74  
 Mountain Mint, 397  
 Mounts, Canada balsam, 21, 22  
     glycerin-gelatin, 22, 23  
     temporary, 20  
     permanent, 20, 23  
 Mucilage, 90, 91  
     cell content, 90, 91  
     defined, 90  
     membrane, 90, 91  
     micro-chemic test for, 91  
 Mucor mucedo, 250  
     stolonifer, 248  
 Mucorales, 248  
 Mucuna pruriens, 344  
 Muhlenbeckia, 321  
 Mulberry Family, 319  
 Musci, 284  
 Mushroom, 274, 275  
 Mustard, corolla of, 186  
 Mustard Family, 334  
     stamens of, 189  
 Mutisia, 404  
 Mycelium, 247  
 Mycobacteriaceæ, 221  
 Mycobacterium, 221  
 Mycorrhiza, 264  
 Myosotis, 389  
 Myrcia acris, 375  
 Myrica N. F., 315  
     Caroliniensis, 133, 314  
     cerifera, 133, 313, 314, 315  
     Gale, 315  
     Macfarlanei, 133  
 Myricaceæ, characters of family, 312,  
     315  
     root tubercles of, 132, 133, 134,  
     135, 312  
 Myricales, 312  
 Myrobalans Family, 375  
 Myristica, 215, 329, 330  
     fragrans, 329, 330  
 Myristicaceæ, 329  
 Myronase, 96  
 Myrosin, 96  
 Myrrh Family, 351  
 Myrrha, 352  
 Myrtaceæ, 374  
     laminæ of, 172  
 Myrtales, 371  
 Myrtifloræ, 371  
 Myrtle Family, 374  
 Myxogastrales, 3  
 Myxomycetes, 230  
 Natural system, 2  
 Naturalized, defined, 1  
 Neea, 84  
 Negundo, 359  
 Nepenthes, 96  
 Nepenthin, 96  
 Nepeta cataria, 397  
 Nephrodium. See *Dryopteris*.  
 Nest fungi, 279

- Nettle family, cystoliths in, 88  
 Nicotiana tabacum, 391  
 Nicotine, micro-chemic test for, 84  
 Nidulariales, 279  
 Nightshade, 391  
     Family, 390  
 Node, 137  
 Nomenclature, 4-7  
 Non-protoplasmic cell contents, 74-96  
 Nostoc, 229  
 Nucellus, 54, 196  
 Nuclear membrane, 61, 69  
 Nuclei, assisting, 200  
     polar, 200  
 Nucleins, 89  
 Nucleolus, 60, 61, 68  
 Nucleus, 60, 68  
     division, 71, 72  
     endosperm, 57  
 Nut, 208  
 Nutgall, Fig. of, 317  
 Nutlet, 206, 207  
 Nutmeg Family, 329  
 Nux Vomica, 215, 329, 384  
     Enzyme in, 95  
 Nyssa, 378  
  
 Oaks, 316  
     black, 317  
     white, 317  
 Ochrea, 169  
 Ocimum Basilicum, 397  
 Ocrea, 321  
 Octant cells, 44  
 Ocular micrometer, 31  
 Oedogonium, 71  
 Oil, benne, 393  
     bitter almond, 92  
     cassia, 92  
     cedarwood, 295  
     chaulmoogra, 368  
     cocoanut, 300  
     linseed, 347  
     mustard, 92  
  
 Oil, palm, 300  
     rose geranium, 346  
     spike, 397  
     turpentine, 92  
 Oils, fixed, 91  
     nitrogenated, 92  
     oxygenated, 92  
     sulphurated, 92  
     volatile, 92  
 Olea Europæa, 381  
 Oleaceæ, 381  
 Oleander, latex of, 94  
 Oleoresins, 92  
 Oleum anisi, 324  
     aurantii florum, 351  
     betulæ, 316  
     bergamottæ, 351  
     cadinum, 295  
     cajeputi, 375  
     chenopodii, 324  
     cinnamomi, 332  
     erigerontis, 407  
     gossypii seminis, 365  
     juniperi, 295  
     lavendulæ, 397  
     lini, 347  
     myristicæ, 330  
     olivæ, 381  
     pini pumilionis, 295  
     rosmarini, 397  
     ricini, 355  
     santali, 320  
     sesami, 393  
     terebinthinæ, 295  
     theobromatis, 362  
     thymi, 397  
     tiglii, 355  
 Olibanum, 352  
 Olive Family, 381  
 Oögonia, 241  
 Oögonium, 245  
 Oömycetes, 251  
 Oöspore, 234, 242  
 Operculina Turpethum, 388

- Operculum, 287  
 Ophioglossales, 3  
 Opium, 94, 333  
 Optical combination, 32  
 Opuntia, 370  
 Opuntiales, 370  
 Orcein, 282  
 Orchid family, 305  
     floral organs of, 307  
 Orchidaceæ, 305  
 Orchideæ, 307  
 Orange, fruit of, 210  
 Order, 2  
 Orders, naming of, 7  
 Ordinary Parenchyma, 101  
 Oregon balsam, 295  
 Organs, essential, 181  
     plant, 121  
     reproductive, 121  
     vegetative, 121  
 Origanum, 397  
     majorana, 397  
     vulgare, 397  
 Oscillatoria, 228, 229  
 Osmic acid, 23  
 Ostwald, 94  
 Ourouparia Gambir, 398  
 Outline of plant groups, 3, 4  
 Ovary, 195  
 Ovule, amphitropous, 197  
     anatropous, 197  
     campylotropous, 197  
     immature angiospermous, Fig.  
         of, 201  
     matured embryo sac in angio-  
         spermous ovule, Fig. of,  
         201  
     orthotropous, 197  
     shape of, 197  
 Ovules, 195  
     defined, 196  
     in angiosperms, 196  
     in gymnosperms, 196  
     position of, 196
- Ovum, 43  
 Oxytropism, 64  
 Pachistima, 356, 357  
 Palaquium, 380  
 Palm cocoanut, 299  
     Date, 299  
     Family, 299  
     oil, 300  
 Palmeæ, 299  
 Panax quinquefolium, 376  
     repens, 376  
 Pandorina, 232  
 Panicle, 179  
 Pansy, papillæ on epidermis. 108  
 Papaver, 332  
     latex of, 94  
     placentation in, 197  
     somniferum, 333  
 Papaveraceæ, 332  
 Papaverales, 332  
 Papain, 96, 369  
 Papaw, 96, 369  
 Papaw Family, 369  
 Papilionaceæ, 341, 342  
 Pappus, 202  
 Paprika, 391  
 Papyrus, 409  
 Paraphyses, 245, 256, 286  
 Parasite, 247  
 Pareira, 328  
 Parenchyma, 101  
     assimilation, 101  
     conducting, 101  
     ordinary, 101  
     phlœm, 101  
     reserve, 103  
     wood, 101  
 Parietales, 366  
 Parmelia, 282  
 Parsley Family, 377  
 Passiflora, 183, 369  
 Passiflora N. F., 369  
     incarnata, 369

- Passifloraceæ, 369  
 Passion Flower Family, 369  
 Pathogens, 219  
 Paullinia, 5  
 Paullinia Cupana, 358  
 Paulownia imperialis, 392  
 Pea Family, 341  
 Peach, 209, 338  
 Pear, 338  
     fruit of, 210  
     stone cells of, 104  
 Peat mosses, 286  
 Pedaliaceæ, 393  
 Pedicel, 178  
 Pedicularis, 392  
 Peduncle, 178  
 Peireskia, 370, 371  
 Pelargonium, 345  
     capitatum, 346  
     odoratissimum, 346  
     Radula, 346  
 Penicillium, 256  
     brevicaule, 260, 261  
     camemberti, 259, 260  
     expansum, 260  
     glaucum, 257, 258, 259  
     roqueforti, 259  
 Pentstemon, 189, 393  
 Peony, 325  
 Pepo, 209  
 Pepper Family, 310  
 Perianth, 185  
 Periblem, 100, 122  
 Pericambium, 37, 124, 126, 127, 128, 140  
 Pericarp, 202  
 Pericladium, 167, 377  
 Pericycle, 37, 140  
 Periderm, 147  
 Peridiolum, 279  
 Peridium, 278  
 Perigone, 183  
 Perithecia, 265, 266  
 Permanent mounts, preparation of, 20-  
     30  
 Peronosporales, 251  
 Pertusaria, 281  
 Petals, 185  
 Petiole, 167, 168  
 Petroselini Radix, 377  
 Petroselinum, 377  
     sativum, 377  
 Petunia, 391  
 Peziza, 256  
     repanda, Fig. of, 256  
 Pezizales, 256  
 Pfeffer, 63  
 Phæophyceæ, 242  
 Phallales, 279  
 Phanerogamia, 292  
 Pharmaceutical Botany, defined, 2  
 Phaseolus lunatus, structure of seed  
     of, 217, 218  
 Phaseolus multiflorus,  
     cross-sections of root of, 126  
 Phelloderm, 147  
 Philadelphus, 336  
 Phloem, defined, 119  
     internal, 145  
     interxylary, 146  
     intraxylary, 146  
     parenchyma, 101  
 Phloroglucin, 98  
 Phœnix, 295  
     sylvestris, 75  
 Photogens, 219  
 Photosynthesis, 40  
     defined, 155  
 Phragmidiothrix, 221  
 Phragmites, 409  
 Phycocyanin, 94  
 Phycoerythrin, 94  
 Phycophæin, 94, 242  
 Phycomycetes, 247  
 Phycoxanthin, 242  
 Phyllotaxy, 156  
 Physcia stellaris, Fig. of, 280  
 Physiology, defined, 1  
 Physostigma, 198, 344



- Physostigma, Fig. of, 345  
     venenosum, 344  
 Phytogeography, 1  
 Phytoglobulins, 89, 90  
 Phytolacca, 132, 324  
     decandra, 324  
     Fig. of, 323  
 Phytolaccaceæ, 324  
 Phytopalæontology, 2  
 Phytopathology, 1  
 Phytophthora, 251  
 Picea, 294  
     canadensis, 295  
     mariana, 295  
     rubra, 295  
 Pickerel weed, 101  
 Picrasma excelsa, 351  
 Picric acid, 23  
 Pigments, 93  
 Pileus, 274  
 Pilobolus, 248  
 Pilocarpus, 349, 350  
     Jaborandi, 350  
     microphyllus, 350  
     neighboring-cells of leaf epidermis,  
         174, 175  
 Pimenta, 374, 375  
     officinalis, 375  
 Pimiento, 391  
 Pimpinella, 378  
     Anisum, 377  
     magna, 378  
     Saxifraga, 378  
 Pinaceæ, 294  
 Pine, inflorescence of, 294  
     Family, 294  
     Stem, 45  
 Pineapple, 96  
 Pinenes, 92  
 Pinites succinifer, 295  
 Pinna, 290  
 Pinnule, 290  
 Pinus, 294  
     alba, 295  
     Pinus, austriaca, 47  
     maritima, 295  
     montana, 295  
     palustris, 295  
     sylvestris, 48  
     strobis, 45, 295  
 Piperaceæ, 310, 311  
 Piper angustifolium, 311  
     cubeba, 311  
     fruit of, 209  
     methysticum, 311  
     nigrum, 311  
     placentation of, 197  
 Piscidia Erythrina, 344  
 Pistacia vera, 356  
     lentiscus, 356  
 Pistachio, 356  
 Pistil, 196  
     dicarpellary, 196  
     monocarpellary, 196  
     polycarpellary, 196  
     tricarpellary, 196  
     system, 195  
 Pix Burgundica, 295  
     Canadensis, 295  
     Liquida, 295  
 Placenta, defined, 197  
 Placentation, 197  
 Plankton, 409  
 Planococcus, 220  
 Planosarcina, 220  
 Plant, acaulescent, 136  
     anemophilous, 199  
     annual, 124  
     biennial, 124  
     caulescent, 136  
     cell, 60  
     diœcious, 183  
     entomophilous, 199  
     geography, 1  
     hairs, 108, 109  
     hydrophilous, 200  
     indigenous, 1  
     monœcious, 182

- Plant, naturalized, 1  
 organs, 121-218  
 perennial, 124  
 tissues, 99-120  
 zoöphilous, 200
- Plantaginaceæ, placentation in, 197
- Plasma membranes, 61, 73
- Plasmodiocarp, 231
- Plasmodium, 230
- Plasmolysis, figure illustrating, 69
- Plastids, 68, 69
- Platystemon, 322
- Plectascales, 256
- Plerome, 100, 122
- Pleurococcaceæ, 232
- Pleurococcus, 232
- Pleuston, 409
- Plum, 209, 338
- Plumule, 121, 135
- Pod, 206  
 Fig. of, 205
- Podophyllum, 327  
 peltatum, 327, 328
- Polemoniales, 386
- Pollen, 54, 55, 193, 195  
 maturation of, 55
- Pollen grains, Fig. of, 194  
 germinating, 56  
 pine, 83
- Pollination, 50, 56, 199
- Pollinia, 195
- Polyembryony, 59
- Polygala, 96  
 lutea, 355  
 senega, 354, 355
- Polygalaceæ, 354
- Polygonaceæ, 197, 321
- Polygonales, 321
- Polygonatum, 302
- Polygonum, 321  
 Bistorta, 322
- Polypodiaceæ, 292
- Polyporaceæ, 274
- Polyporus, enzyme in, 95
- Polyporus, officinalis, 274
- Polytrichum commune, Fig. of, 285  
 life history of, 286, 287
- Pome, 209  
 of apple, Fig. of, 210
- Pomegranate Family, 371
- Ponteria, 380
- Poplar, 312
- Poppy, calyx of, 184  
 Family, 332
- Populi Gemmæ, 312
- Populus balsamifera, 312  
 nigra, 312
- Pore Fungi, 274
- Porella, 283
- Potato, 391
- Potentilla, 185  
 silvestris, 341
- Prefloration, 181
- Prefoliation, 157, 158
- Prickles, 138
- Primula, style of, 199
- Primulaceæ, placentation in, 197
- Principes, 299
- Principles of classification, 2, 3
- Privet, 381  
 California, 127
- Proembryo, 242
- Promycelium, 267
- Proportions of stamens, 189
- Protective tissues, 120
- Proteins, 40, 89  
 tests for, 89
- Prothallial cushion, 43
- Prothallus, 41, 290
- Protoascales, 251
- Protobasidiomycetes, 267
- Protococcales, 232
- Protonema, 41, 283
- Protophloem, 127, 129, 143
- Protophyta, 219
- Protoplasm, 62  
 properties of, 62, 68
- Protoplasmic cell contents, 68-70

- Protoxylem, 127, 129, 143  
 Prune, 209  
 Prunum N. F., 340  
 Prunus, 4  
     amygdalus var. amara, 340  
     cerasus, 91  
     domestica, 340, 341  
     serotina, 338  
     virginiana, 6  
 Pseudocarp, 202  
 Pseudobulbs, 137  
 Pseudomonas radiculicola, 132  
     Fig. of, 134  
 Pseudopodia, 230  
 Pseudotsuga mucronata, 295  
 Ptelea, 350  
     trifoliata, 351  
 Pteridophyta, 287-292  
 Pterocarpus marsupium, 344  
     santalinus, 343  
 Puccinia Graminis, 270  
 Puff Balls, 278  
 Pulsatilla, 327  
 Pulvinus, 167  
 Pumpkin, 400  
 Punica, 371  
     Granatum, 372  
 Punicaceæ, 371  
 Purging Cassia, 6  
 Purified Siliceous Earth, 239  
 Putamen, 202  
 Pycnanthemum Montanum, 397  
 Pyrenoid, 235, 236  
 Pyrenomycetales, 265  
 Pyrethri Flores, 406  
 Pyrethrum, 406  
 Pyrola, 380  
 Pyrus malus, 340  
 Pyxis, 206  
  
 Quassia, 351  
     amara, 351  
 Quercus N. F., 319  
     alba, 316, 319  
     Quercus, N. F., chrysolepis, 316  
         garryana, 316  
         infectoria, 317, 319  
         michauxii, 316  
         occidentalis, 316  
         platanoides, 316  
         prinus, 316  
         Suber, 316  
         velutina, 316  
         virginica, 316  
     Quillaja N. F., 338  
         Saponaria, 338  
 Quince, fruit of, 210  
  
 Raceme, 179  
 Rachis, 178  
 Radicle, 121  
 Ranales, 324  
 Ranunculaceæ, 324  
 Ranunculus, 324  
 Raphe, 197, 214  
 Raphides, 86, 87  
 Raspberry, 210  
     fruit of, 210  
 Receptacle, 183  
 Receptacles of Fucus, 243, 244  
 Regma, 205, 206  
 Rejuvenescence, 71  
 Reproduction, asexual, 70  
     defined, 68, 70  
     sexual, 70  
     vegetative, 42  
 Resin, micro-chemic test for, 93  
 Resina, 295  
 Resins, 92  
 Resinogenous layer, 92  
 Reserve cellulose, 98  
     parenchyma, 103  
     starches, 77-81  
 Respiration, 155  
 Rhamnales, 359  
 Rhamnase, 96  
 Rhamnose, 96

- Rhamnus cathartica*, 359  
     *Frangula*, 96, 359  
     *Purshiana*, 359  
*Rheum*, 322  
     *officinale*, 322  
     *palmatum*, 321, 322  
     *tanguticum*, 322  
*Rhinanthus*, 392  
*Rhizoids*, 283, 286, 290  
*Rhizome*, defined, 139  
*Rhizopora*, 410  
*Rhizopus*, 249  
     *nigricans*, 248  
*Rhododendron*, 191  
*Rhodophyceæ*, 246  
*Rhodymenia palmata*, 247  
*Rhœadales*, 332  
*Rhubarb*, 322  
*Rhus*, *cotinus*, 356  
     fruit of, 209  
     *Glabra* N. F., 356  
     *japonica*, 356  
     *semialata*, 356  
     *toxicodendron*, 356  
     *typhina*, 356  
     *venenata*, 356  
*Ribes*, 336  
*Riccia*, 283, 409  
*Riccicarpus*, 409  
*Ricinus communis*, 355  
*Rocella*, 281  
*Rock Rose Family*, 369  
*Root*, defined, 121  
     *adventitious*, 123  
     *anomalous*, 123  
     *California Privet*, 127-131  
     *cap*, 121, 122  
     *classification as to form*, 123  
     *conical*, 123  
     *distinction from stem*, 123  
     *duration of*, 124  
     *epiphytic*, 123  
     *functions*, 121  
     *fusiform*, 123  
     *Root*, generative tissues of, 122  
         *hairs*, 121, 122  
         *histology*, 124-132  
         *lateral*, 123  
         *primary*, 123  
         *secondary*, 123  
         *system*, 133  
         *tubercles*, 132-135  
*Roots*, *Dicotyledon*, 125  
     *abnormal structure in*, 132  
     *of parasitic plants*, 123  
     *of primary growth*, 125, 126  
     *of secondary growth*, 126, 127  
     *Monocotyledon*, 124  
     *multiple*, 123  
     *napiform*, 123  
     *nodule producing*, 132  
*Rootlet*, cross section of in region of  
     *root hairs*, 122  
*Roridula*, 335  
*Rosa canina*, 341  
     *centifolia*, 341  
     *gallica*, 338  
*Rosa Gallica*, 338  
*Rosaceæ*, 338  
*Rosales*, 336  
*Rose*, 338  
     *Family*, 338  
*Rosette aggregates*, 86, 87  
*Rosmarinus officinalis*, 397  
*Rubber*, 94  
*Rubi Fructus*, 340  
*Rubi Idæi Fructus*, 340  
*Rubiaceæ*, 398  
*Rubiales*, 398  
*Rubus* N. F., 338  
     *cuneifolius*, 338  
     *Idæus*, 340  
     *nigrobaccus*, 338  
     *strigosus*, 340  
     *villosus*, 338  
*Rue Family*, 349  
*Ruellia ciliosa*, 395  
*Rumex* N. F., 270

- Rumex, 321  
     acetosella, 321  
     crispus, 322  
     obtusifolius, 322  
 Rust, wheat, 269, 270, 271  
 Rusts, 268  
 Ruta, 349  
     graveolens, 351  
 Rutaceæ, 349  
     hesperidin in, 82  
 Ruteæ, 349  
  
 Sabal, 209, 300  
 Sabbatia angularis, 384  
 Sabina, 295  
 Saccharomyces anomalus, 252  
     apiculatus, 256  
     cerevisiæ, 251, 252, 253, 254  
     ellipsoideus, 251, 252, 256  
     exiguus, 251  
     farinosus, 252  
     hyalosporus, 252  
     Ludwigii, 251  
     mali Duclauxii, 251  
     marxianus, 251  
     membranifaciens, 252  
     octosporus, 95  
     pastorianus, 251  
 Saccharomycetaceæ, 251  
 Saccharum, 299, 324  
     officinarum, 299  
 Saddle Fungi, 264  
 Salep, 91  
 Salicaceæ, 311  
 Salicales, 311  
 Salicin, 82, 311, 312  
     micro-chemic test for, 82  
 Salicornia, 410  
 Salix, 312  
     alba, 312  
 Salvia, 396, 397  
     officinalis, 397  
 Salvina, 292  
 Samara, 207  
  
 Sambucus, 399, 400  
     canadensis, 400  
     nigra, 400  
 Samphire, 410  
 Sandalwood Family, 319  
 Sandaraca, 295  
 Sandbox, 206, 355  
 Sanguinaria canadensis, 333  
 Sansevieria cylindrica, leaf of, 172  
 Santalaceæ, 319  
 Santalales, 319  
 Santalum album, 320  
     Rubrum, 343  
 Santonica, 407  
 Santoninum, 406  
 Sap, cell, 258  
     crude, 39  
     elaborated, 116  
     nuclear, 71  
     vacuoles, 61  
 Sapindaceæ, 358  
 Sapindales, 356  
 Saponin, micro-chemic test for, 83  
 Sapotaceæ Family, 380  
 Saprogens, 219  
 Saprolegniales, 251  
 Saprophyte, 247  
 Sarcina, 220, 222  
 Sarcocarp, 203  
 Sarcosphæra, 257  
 Sarracenia, style of, 198  
 Sarraceniales, 335  
 Sarsaparilla, 303  
     endodermis of Mexican root, 110  
     of Honduras root, 110  
     Fig. of Honduras root in T. S., 125  
 Sassafras, 331, 332  
     Medulla, 332  
     variifolium, 332  
 Satureia hortensis, 397  
 Saw Palmetto Palm, Fig. of, 300  
 Saxifragaceæ, 336  
 Saxifrage, 336  
     Family, 336

- Scale leaves, 156  
 Scales, 109  
 Scammonia Radix, 388  
 Scape, 138  
 Schizomycetes, 219  
 Schizophyta, 219  
 Schleiden, 60  
 Schulze's process of maceration, 30, 31  
 Scilla, 303  
 Scitaminales, 304  
 Sclerenchyma, 103  
   fibers, 105  
 Sclerotium, 265  
 Scoparius, 344  
 Scopola Carniolica, 391  
 Scorpioid cyme, 180  
 Scotch Pine, 48  
 Scouring Rushes, 289  
 Scrophularia, 393  
 Scrophulariaceæ, 392  
 Scullcap, 396  
 Scutellaria lateriflora, 397  
 Secale cereale, 265  
 Secretion canals, 119, 120  
   reservoirs, 119, 120  
   sacs, 119  
 Secretory cells, 113  
 Sections, making of, 15  
   celloidin, 29  
   paraffine, 26, 27  
   radial-longitudinal, 16  
   tangential-longitudinal, 16  
   transverse, 16  
 Seed, 213  
   appendages, 213, 214  
   albuminous, 215  
   coats, 213, 214  
   defined, 213  
   Dicotyl, 217  
   exalbuminous, 215  
   germination, 216  
   histology, 215-218  
   Monocotyl, 215, 216  
 Seed-grass, 409  
 Seedling, 216, 217  
   of White Pine, 52  
 Selaginella, 288  
   Martensii, 289  
 Selaginellaceæ, 288  
 Semen Rapæ, 335  
 Senecio N. F., 406  
   aureus, 406  
 Senega, 355  
 Senna, 343  
   neighboring cells of, 174  
   stomatal apparatus of, 175  
   trichomes of, 107  
 Sepaline, position, 185  
   spurs, 184  
   stipules, 184  
 Sepals, 183  
   epigynous, 184  
   hypogynous, 184  
   perigynous, 184  
 Serenoa serrulata, 300  
 Serpentaria, 321  
 Serphyllum, 397  
 Sesame Family, 393  
 Sesamum indicum, 393  
 Sieve, 112  
   callus of plates, 98  
 Silica, 88  
 Siliceous Earths, 239  
 Silicule, 206  
 Siliqua, 206  
 Simaruba amara, 351  
   officinalis, 351  
 Simarubaceæ, 351  
 Sinapis alba, 335  
   nigra, 335  
 Sinigrin, 96  
 Siphonales, 241  
 Sitotropism, 64  
 Skunk Cabbage, 301  
 Slime Molds, 230  
 Smilax, 302  
   medica, 303  
   officinale, 303

- Smilax*, ornata, 303  
 Smuts, 267  
 Soapwort Family, 358  
 Soft bast, 144  
 Solanaceæ, 390  
 Solaneæ, 191  
 Solanine, micro-chemic test for, 85  
 Solanum N. F., 391  
 Solanum, 391  
     *carolinense*, 391  
     *Dulcamara*, 391  
     *tuberosum*, 85  
 Sorbinose, 74  
 Soredia, 281  
 Sorghum, 75, 299  
 Sorosis, 211  
 Sorus, 40, 290  
 Sour Gum, 378  
 Soy Bean, 344  
 Spadix, 179  
 Sparganium, 409  
 Spathe, 178  
 Species, 2  
 Spermacia, 271  
 Spermagonia, 271  
 Spermatoocyte, 43  
 Spermatophyta, 292  
     outline of, 4  
 Spermatozoid of fern, 43  
 Spermoderm, 213  
 Sperms, 245  
 Sphærella, 232  
 Sphagnales, 286  
 Sphagnum, 286  
     *acutifolium*, 284  
     *squarrosus*, 284  
 Spicebush, 331  
     Family, 330  
 Spiderwort, 66  
 Spigelia, 382, 383  
     *marilandica*, 384  
 Spike, 179  
 Spinach, 323  
 Spine, 138  
 Spirilla, types of, 221  
 Spirillum, 221  
     *cholerae asiaticæ*, 224  
     *obermeieri*, 224  
 Spirochæta, 221  
 Spirogyra, 236  
     life history of, 236, 237, 238  
 Spirosoma, 221  
 Sporangiohores, 248  
 Spore, 41  
     brand, 267  
 Sporogonium, 283, 286  
 Sporophore, 274  
 Sporophyte, 33, 44  
 Spruce Gum, 295  
 Spurge Family, 355  
 Spur shoot, 47  
 Spurs, sepaline, 184  
 Staff Tree Family, 356, 357  
 Stage micrometer, 31  
 Stain, for "acid proof" bacteria, 226  
     Broca's differential, 227  
     Delafield's hæmatoxylin, 29  
     Ehrlich's gentian violet, 226  
     Gram's, 225  
     Löffler's methylene-blue, 226  
     Van Ermengem's flagella, 226, 227  
     Ziehl's carbol-fuchsin, 226  
 Staining, 21, 22, 28, 29  
     of bacteria, 224-227  
 Stamen System, 188  
 Stamens, color of, 190  
     connation of, 189  
     definite, 188  
     diadelphous, 189  
     didynamous, 189  
     epigynous, 189  
     gynandrous, 189  
     histology of parts, 190-195  
     hypogynous, 189  
     indefinite, 188  
     insertion of, 189  
     monadelphous, 189  
     perigynous, 189

- Stamens, polyadelphous, 190  
 proportions of, 189  
 tetradynamous, 189  
 triadelphous, 189
- Standardization of ocular micrometer,  
 31
- Staphisagria, 325
- Staphylococcus, 220, 222  
 pyogenes aureus, 224
- Star Apple Family, 380
- Starch, 75  
 assimilation, 75  
 Barley, 78, 79  
 Bean, 80, 81  
 Buckwheat, 79  
 Canna, 81  
 Cassava, 80, 81  
 characteristics of commercial  
 kinds, 77-81  
 compound grains, 77  
 Corn, 79, 80  
 fill, 77  
 Maranta, 78, 79  
 Pea, 80, 81  
 Potato, 78, 79  
 Rice, 79, 80  
 Rye, 78, 79  
 Sago, 78, 81  
 reserve, 76  
 structure and composition of, 76  
 Wheat, 78, 79
- Steckbeck, 68
- Stem, defined, 136  
 direction of growth, 137  
 distinction from root, 123  
 functions, 136  
 generative tissues of, 137  
 modification of, 137, 138
- Stemonitis fusca, 230
- Stems, above-ground, 138  
 aerial-tuberous, 137  
 annual, 137, 138  
 ascending, 137  
 biennial, 137
- Stems, cactoid, 138  
 climbing, 138  
 decumbent, 137  
 duration of, 137  
 elongation of, 137  
 endogenous, 139, 140  
 exceptional types of dicotyl, 145,  
 146  
 exogenous, 139  
 fruticose, 138  
 herbaceous, 138  
 histology of annual dicotyl, 140-  
 142  
 of perennial dicotyl, 143-145  
 of herbaceous monocotyl, 152  
 of woody monocotyl, 153, 154  
 perennial, 138  
 phylloid, 138  
 procumbent, 137  
 reclining, 137  
 repent, 137  
 scandent, 138  
 size of, 136  
 spiny, 137  
 subterranean tuberous, 138  
 suffruticose, 138  
 tendriform, 137  
 twining, 137  
 underground, 139
- Sterculiaceæ, 361
- Sterigmata, 258, 259, 266
- Sterigmatocystis niger, 264<sup>1</sup>
- Stevens, 85
- Stigma, 196, 199  
 defined, 199  
 of animal pollinated flowers, 199  
 of wind pollinated flowers, 199  
 papillæ of, 199
- Stillingia, 355  
 sylvatica, 355
- Stimuli, extrinsic, 62  
 intrinsic, 62
- Stink horn, 279
- Stipe, 265, 274, 290



- Stipule, defined, 168  
 Stipules, 168, 169  
     axillary, 169  
     caducous scaly, 169  
     lateral, 168  
     modified, 169  
     sepaline, 184, 185  
 Stolon, 138  
 Stoma mother-cell, 174  
 Stomata, 106  
     structure and development of,  
         173-176  
     transpiration, 106  
     water, 106  
 Stone cells, 103  
 Stone cells, defined, 103  
     Figs. of, 102, 104  
 Stoneworts, 241  
 Stramonium, 391  
 Strawberry, 338  
 Streptococcus, 220, 222  
     erysipelatis, 224  
     pneumoniæ, 224  
 Streptothrix, 221  
     bovis, 224  
 Strobile, 210, 211  
 Stromata, 214  
 Strophanthin, micro-chemic test for,  
     82  
 Strophanthus, 386  
     hispidus, 385, 386  
     Kombe, 386  
 Strychnine, micro-chemic test for, 83  
 Strychnos Ignatii, 384  
     Nux Vomica, 382, 384  
 Style, 195, 198  
     arms, 198  
     collecting hairs of, 198  
     column, 198  
 Styloids, Fig. of, 86  
 Styracæ, 381  
 Styrax, 338  
     Benzoin, 381  
 Suberin, 97  
     Suberized walls, 98  
     Sub-hymenium, 275  
     Succinum, 295  
     Succus Citri, 351  
         Pomorum, 340  
     Sucrose, 74  
     Sudan III, 98  
     Sugar cane, 75  
     Sugars, 74  
         Flückiger's micro-chemic test for  
             determination of various  
             kinds of, 74  
     Sumac Family, 356  
     Sumbul, 377  
     Summer Savory, 397  
     Sundew, effect of stimulus applied to  
         tentacles of, 67  
     Surirella, 240  
     Sutures, 202  
     Swarm spores, 231  
     Sweet Basil, 397  
     Sweet Potato, 387  
     Swertia Chirayita, 384  
     Syconium, 210, 211  
     Sympetalæ, 378  
     Symphytum, 389, 390  
     Symplocarpus fœtidus, 301  
     Synchytrium, 251  
     Synedra, 240  
     Synergids, 55  
     Syringa, 381  
     Systematic Botany, 219-407  
         defined, 1  
     Tabacum, 391  
     Tamarindus, 344  
         indica, 344  
     Tanacetum, 407  
         vulgare, 407  
     Tannins, definition, 88  
         kinds of, 88  
         properties of, 88  
         tests for, 88  
     Tapetum, 191, 193

- Tapioca, 355  
 Taraxacum officinale, 406  
 Taxodium, 410  
 Taxonomy, defined, 1  
 Taxus, 294  
 Tea Family, 366  
 Teak-wood, 395  
 Tectona, 395  
 Tegmen, 213  
 Tela contexta, 275  
 Teleutospores, 270  
 Teliospores, 270  
 Tendril, 138  
 Terebinthina, 295  
     *Canadensis*, 295  
     *Laricis*, 295  
 Ternstroemiaceæ, 366  
 Terpenes, 92  
 Terra Silicea Purificata, 239  
 Testa, 213  
 Tetrads, 193  
 Tetraspores, 246  
 Thalamus, 183  
 Thallophyta, 219  
     outline of, 3  
 Thallus, 219  
 Thamnidium, 248, 250  
 Thea sinensis, 366  
 Theaceæ, 366  
 Thelephorales, 273  
 Theobroma, 361  
 Theobroma Cacao, 362  
 Thermotropism, 63  
 Thigmotropism, 66-68  
 Thiothrix, 222  
 Thistle, 404, 406  
 Thorn, 138  
 Thornapple, 391  
 Throat, 184  
 Thuja, 294, 295  
     *occidentalis*, 295  
 Thymeleaceæ, 371  
 Thymus Serphyllum, 397  
     *vulgaris*, 397  
 Thyrsus, 180  
 Tilia, 363  
 Tiliaceæ, 361, 363  
 Tissue, 99  
     assimilation parenchyma, 101  
     chlorenchyma, 101  
     collenchyma, 102, 103  
     conducting parenchyma, 101  
     cork, 110  
     cribiform, 112  
     embryonic, 100  
     endodermal, 110  
     epidermal, 106-109  
     fundamental, 101  
     generative, 99, 100  
     ground, 101  
     laticiferous, 110  
     medullary ray, 116  
     meristematic, 100  
     ordinary parenchyma, 101  
     reserve parenchyma, 103  
     sclerenchyma, 103-105  
     sieve, 112  
     stony, 103  
     suberous, 110  
     tracheary, 112, 116  
 Tissues, 99-120  
     classified accd. to function, 120  
 Tobacco, 391  
 Toluifera Balsamum, 343  
     *Pereiræ*, 343  
 Tomato, 208, 391  
 Tooth Fungi, 274  
 Tormentilla, 341  
 Torus, 183  
 Touranose, 75  
 Toxins, 63  
 Tracheæ, 112, 113, 115  
 Tracheary tissue, 112  
 Tracheids, 116, 151  
 Tradescantia zebrina, 69  
 Tragacanth, 91  
 Tragacantha, 342  
 Trailing Arbutus, 380

- Trama, 275  
 Transpiration, 155  
     Stomata, 106  
 Tree, 138  
 Trees, branching in, 139  
 Trehalase, 95  
 Trehalose, 75  
 Tremellaceæ, 272  
 Tremellales, 271  
 Trichomes, 107, 108, 109  
 Trifolium N. F., 344  
     pratense, 344  
     repens, 341  
 Trigonella Fœnum-græcum, 344  
 Trillium, 303  
 Tristicha, 88  
 Triticum, 299  
 Tropophytes, 411  
 True Mosses, 286  
 Truffles, 264  
 Trunk, 138  
 Trypsin, 96  
 Tschirch, 92  
 Tsuga canadensis, 295  
 Tuber, 139  
 Tuberales, 264  
 Tubifloræ, 386  
 Turnera aphrodisiaca, 369  
     diffusa, 369  
 Turneraceæ, 368  
 Turpentine, 295  
     Bordeaux, 295  
 Turpeth Root, 388  
 Tussilago Farfara, 406  
 Twin crystals, 86  
 Typha, 193, 194, 409  
  
 Ulmaceæ, 319  
 Ulmus, 91, 319  
     fulva, 319  
 Ulothricaceæ, 234  
 Ulothrix zonata, 234, 235  
 Umbel, 179  
 Umbellales, 376  
  
 Umbelliferæ, 377  
 Umbellifloræ, 376  
 Uredinales, 268  
 Uredinium, 270  
 Uredo linearis, 270  
 Uredospore, 270  
 Urginea maritima, 303  
 Urticales, 319  
 Usnea, 281, 282  
 Ustilaginales, 267  
 Ustilago Maydis, 267  
     Zeæ, 267  
     Fig. of, 268  
 Utricle, 208  
 Utricularia, 172  
 Uva, 209  
 Uva Ursi, 380  
     neighboring cells of leaf epidermis, 174, 175  
  
 Vaccineæ, 380  
 Vaccinium, 380  
 Vacuole, glycogen, 252  
 Vacuoles, sap, 61  
 Valerian Family, 402  
 Valeriana, 402  
     officinalis, 402  
 Valerianaceæ, 402  
 Valves of fruits, 202  
 Vanilla, 308  
     planifolia, 308  
     histology of fruit, 211, 212  
 Varieties, naming of, 6  
 Variety, 2  
 Vaucheria, 91, 241  
 Vaucheria terrestris, 235  
 Vavæa, 353  
 Veil, partial, 275  
     universal, 277  
 Venation, leaf, 159  
 Venus fly-trap, 65, 67  
 Veratrina, 303  
 Veratrine, micro-chemic test for, 84

- Veratrum, 303  
     album, 84  
     viride, 303  
 Verbasci Flores, 393  
     Folia, 393  
 Verbascum, 189, 393  
     Blattaria, 392, 393  
     phlomoides, 393  
     Thapsiforme, 393  
     Thapsus, 392, 393  
 Verbena N: F., 395  
     hastata, 395  
 Verbenaceæ, 395  
 Vernation, 157, 158  
 Veronica, 189, 392, 393  
     virginica, 393  
 Verticillaster, 180  
 Viburnum, 399  
     Lentago, 400  
     Opulus, 400  
     Prunifolium, 400  
 Vinca, style of, 198  
 Vinum Xericum, 361  
 Viola tricolor, 368  
     style of, 198  
 Violaceæ, 368  
 Viscum, 59  
 Vitaceæ, 359  
 Vitis, 361  
 Volatile oils, 92  
 Volvocales, 232  
 Volvox globator, life history of, 232-  
     234  
 Vouacapoua Araroba, 344  
  
 Walnut Family, 315  
 Waltheria, 361  
 Water Ferns, 292  
 Water Leaf Family, 388  
 Watermelon, 400  
     seed, 401  
 Water stomata, 106  
 Weigelia, 399, 400  
 Welwitchia, 58  
  
 Weymouth Pine, 45  
 Wheat, Fig. of plant, 297  
     rust, 269  
 Wheat, Fig. of fruit, 208  
     starch, 78, 79  
 White Pine, life history of, 45-52  
 Wild Black Cherry, 6, 96  
     Cherry, 4  
 Willow, 311, 312  
 Winter's Bark, 324  
 Witchhazel Family, 337  
 Wood, defined, 150  
     fibers, 105  
     heart-, 152  
     microscopic characters of angio-  
         spermous and gymnosper-  
         mous, 152  
     parenchyma, 101  
     pine, 151  
     sap-, 152  
 Wood Rush, parenchyma of, 101  
  
 Xanthophyll, 93  
 Xanthoxyli Fructus N. F., 351  
 Xanthoxylum, 350, 351  
     americanum, 351  
     Clava-Herculis, 351  
 Xerophytes, 410  
 Xylem, 119  
     stages in development of elements  
         of, 114  
  
 Yam Family, 393  
 Yeasts, bottom, 255  
     defined, 251  
     Hansen's classification of, 251, 252  
     top, 255  
 Yucca, 301  
  
 Zanthoxyleæ, 349  
 Zea N. F., 299  
     Mays, 299  
     bundle of stem of, 115  
     inflorescences of, 298

Zedoaria, 255  
Ziehl's Carbol-fuchsin, 226  
Zingiber, 304  
    officinale, 304  
    Fig. of, 306  
Zingiberaceæ, 304  
Zoöglæa, 133  
Zoöspore, 71

Zoöspores, 231, 235  
Zygnemaceæ, 236  
Zygomycetes, 248  
Zygophyllaceæ, 348  
Zygospore, 231, 235, 250  
Zygote, 71  
Zymase, 74, 95  
Zymogens, 219

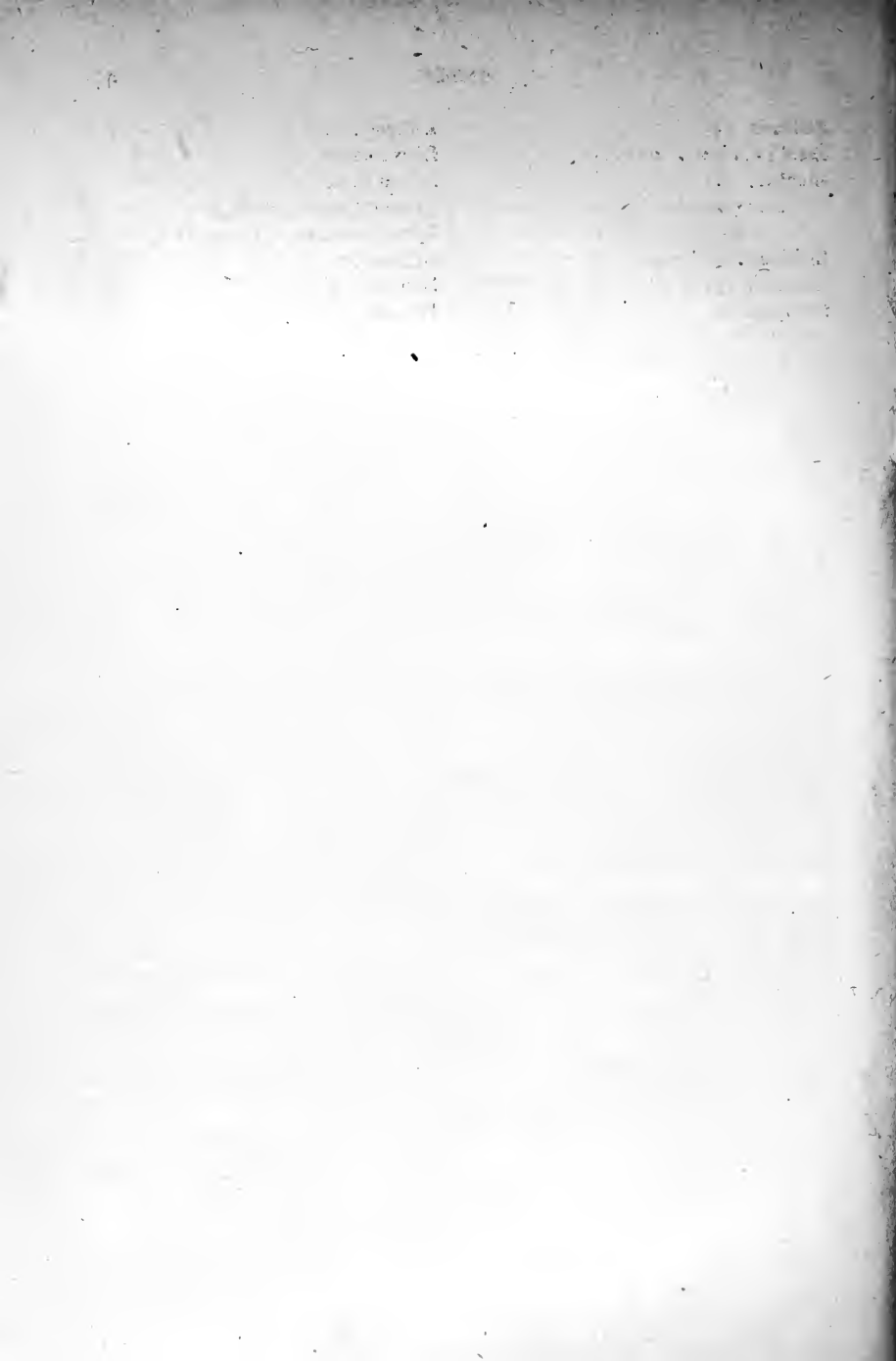







MP 43

Y.

177724

Author Youngken, Heber Wilkinson

Title Pharmaceutical botany.

University of Toronto  
Library

DO NOT  
REMOVE  
THE  
CARD  
FROM  
THIS  
POCKET

3-5415  
Pharmaceutical botany

Acme Library Card Pocket  
Under Pat. "Ref. Index File"  
Made by LIBRARY BUREAU

