

UC-NRLF

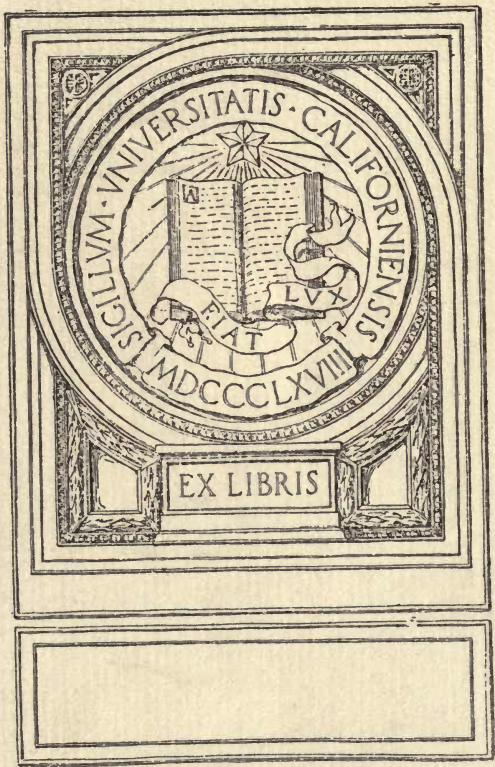

B 4 595 974





EX LIBRIS

MODERN
PUMPING AND HYDRAULIC MACHINERY.

Charles Griffin & Co., Limited, Publishers.

*** Note.—All prices are net, postage extra.*

WORKS BY EDWARD BUTLER, M.I.Mech.E.

SECOND EDITION. In Demy 8vo. Pp. i-xvi + 273. Profusely Illustrated. 21s.
INTERNAL COMBUSTION ENGINE DESIGN AND PRACTICE.

A full and detailed prospectus of this book may be had post free on application.

SECOND EDITION. In Demy 8vo. Handsome Cloth. Pp. i-viii + 288.
With over 190 Illustrations. 12s. 6d.

CARBURETTORS, VAPORISERS, AND VALVES *USED IN INTERNAL COMBUSTION ENGINES.*

"Mr. Butler writes with an intimate practical knowledge of his subject, and the book is one we have every pleasure in recommending."—*Mechanical Engineer.*

FOURTH EDITION. In Large Crown 8vo. Cloth. Pp. i-xvi + 310.
With 155 Illustrations. 12s. 6d.

OIL FUEL: Its Supply, Composition, and Application.

"Mr. Butler plunges into the details . . . with a completeness that makes him something of an ideal author in this respect."—*Gas and Oil Power.*

"It is a most useful book for all who are interested."—*Locomotive.*

WORKS ON HYDRAULICS, Etc.

THIRD EDITION, Thoroughly Revised and Enlarged. Pp. i-xvi + 227.
With 60 Plates and 71 other Illustrations. Handsome Cloth. 30s.

HYDRAULIC POWER AND HYDRAULIC MACHINERY.

BY HENRY ROBINSON, M.INST.C.E., F.G.S.

"The standard work on the application of water power."—*Cassier's Magazine.*

SECOND EDITION, Thoroughly Revised. In Cloth. With 126 Illustrations in the Text, and 41 Plates. 21s.

A TEXT-BOOK OF PRACTICAL HYDRAULICS,

*For the use of Mining Schools, Technical Colleges,
County, and Hydraulic Engineers.*

BY PROF. JAS. PARK, F.G.S., M.INST.M.M.

CONTENTS.—Some First Principles.—Definition of Terms.—Flow of Water Through Orifices.—Friction in Pipes and Channels.—The Discharge of Pipes.—Flow of Water in Open Channels.—Over Weirs and Notches.—In Rivers.—Construction of Pipes.—Construction of Flumes.—Construction of Ditches.—Masonry and Concrete Dams.—Earthen Dams.—Water Power and Water Prime Motors.—APPENDIX.—INDEX.

"A particularly full treatise on the use of water and water-power."—*Iron and Coal Trades Review*

SECOND EDITION. In Cloth. With 160 Illustrations, including 16 Plates, and with Many Tables. 15s.

CENTRIFUGAL PUMPING MACHINERY.

BY E. W. SARGEANT.

"The letterpress is commendably clear, as are the illustrations . . . sure to be of value."—*Shipbuilder.*

In Handsome Cloth. Fully Illustrated.

AUTOMATIC PUMPING

AND NOTES ON WATER ANALYSIS AND FILTRATION.

By W. WALKER FYFE.

LONDON: CHARLES GRIFFIN & CO., LTD., EXETER STREET, STRAND, W.C. 2.

MODERN PUMPING AND HYDRAULIC MACHINERY

*AS APPLIED TO ALL PURPOSES, WITH EXPLANATION OF THE
THEORETICAL PRINCIPLES INVOLVED, CONSTRUCTION,
WORKING, AND RELATIVE ADVANTAGES.*

BEING A PRACTICAL HANDBOOK FOR ENGINEERS,
DESIGNERS, AND OTHERS.

BY

EDWARD BUTLER, M.I.MECH.E.,

AUTHOR OF "CARBURETTORS, VAPORISERS, AND DISTRIBUTING VALVES"; "INTERNAL
COMBUSTION ENGINE; DESIGN AND PRACTICE," ETC.

SECOND EDITION, REVISED.

WITH 345 SETS OF ILLUSTRATIONS.



LONDON:
CHARLES GRIFFIN AND COMPANY, LIMITED;
EXETER STREET, STRAND, W.C.2.
1922.

[*All Rights Reserved.*]

TJ900

B8

1922

G. E. P.

PREFACE TO SECOND EDITION.

THE reception given to this book by the technical Press interested in the subject was most gratifying, and engineers engaged in the construction of pumping and hydraulic machinery, as well as advanced students, lost no time in obtaining copies. The outbreak of war just as the book was made known diverted interest to other subjects of more pressing need, yet, notwithstanding this and the trade slump which followed the war, a new edition is already called for. Developments in the art of building and operating hydraulic machinery have also been retarded, and it follows that for this edition only essential alterations are necessary. To practical engineers and designers the wealth of sectional views of machinery with which the subject is illustrated will appeal more than photographs of recent machines, designs and specialities. The subject is so wide that for special branches of it reference must be made to other books; thus, for *Centrifugal Pumps and Suction Dredgers* Mr. E. W. Sargeant's work should be consulted, and for *Automatic Pumping*, a new work now at press, by W. Walker Fyfe, will give full information. The available supply of water power and its possibilities has been forced upon the attention of engineers by the greatly increased cost of coal and the unceasing demand for power. In this edition, therefore, the theory and practice of the application of water power have been very extensively dealt with and graphically explained, as the author is of opinion that all manufacturing countries will need to give most careful consideration to this source of power.

E. B.

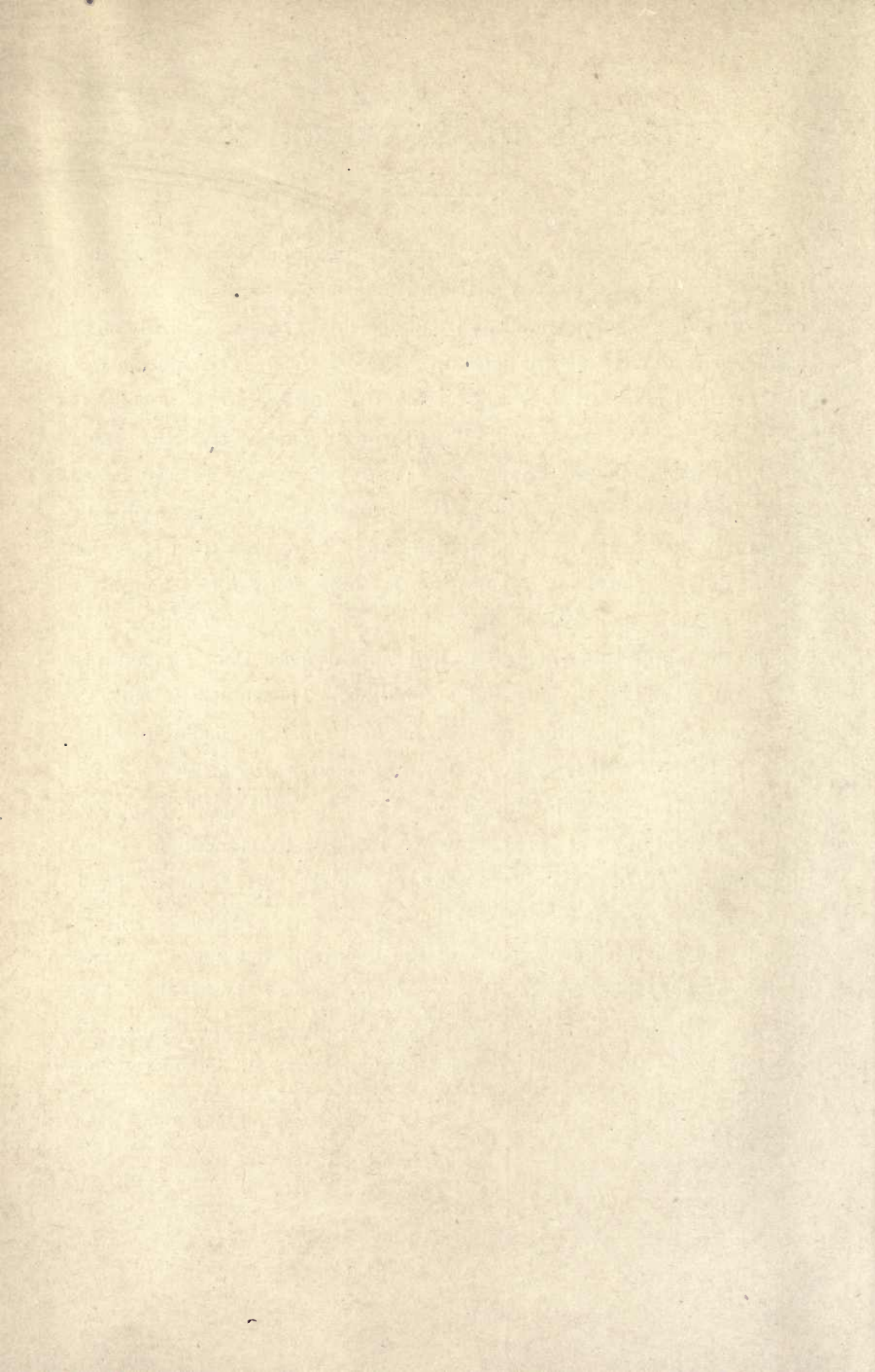

P R E F A C E.

THE object of this treatise is to present in a clear and concise form information specially useful to practical engineers, designers, and others engaged either in the construction or application of Pumping and Hydraulic Machinery for any of the numerous purposes, where-with this useful and, in many respects, indispensable class of machinery can be employed.

An impression of the extent and varied application of pumping and hydraulic machinery will be at once gathered by a glance at the Contents. This including, in addition to that used for water supply, wells, mines, etc.; drainage, irrigation, dredging, and reclamation work—all classes of direct-acting steam pumps, injectors, and condenser pumps; fire pumps, high-speed, and that useful class known as variable-delivery constant-speed pumps.

Besides rotary, centrifugal, and turbine pumps, there must also be included steam, air, gas, and hydraulic direct-displacement, or pulsator pumps, as well as air-lift or aeration pumps, together with the various appliances especially adapted for raising petroleum from deep wells. In all of these separate and distinct classes of pumps, in addition to a number of typical examples illustrating the most modern practice—the construction, working, and relative advantages have been impartially considered—an explanation has also been given wherever necessary of the theoretical principles involved.

The increasing use of internal-combustion power for automobile and maritime propulsion, a subject fully dealt with by the author in *The Evolution of the Internal Combustion Engine*, recently published,

lends additional interest to that part of the work devoted to a description and analysis of the various hydraulic power transmission systems in use. Hydraulic turbines, too, although not so important a subject perhaps for this country, constitutes, nevertheless, one of vital concern to many other parts of the world ; a chapter, therefore, has been included dealing extensively with the theory and possibilities of water power, together with a number of practical examples demonstrating the relative adaptability of the several types of motors available for varying conditions of pressure head and other factors.

It has been the endeavour of the author to treat exhaustively and systematically the whole range of pumping appliances, as well as the various machinery used in hydraulic transmission and generation of power. In so doing, a series of articles contributed to the *Mechanical Engineer* have been largely drawn upon, through the courtesy of the editor, and the author's thanks are here tendered, as also to the various firms who have kindly afforded information regarding their productions.

EDWARD BUTLER.

February, 1913.

CONTENTS.

CHAPTER I.

	PAGES
INTRODUCTORY REMARKS,	1-3

CHAPTER II.

EARLY DIRECT-ACTING STEAM PUMPING ENGINES,	4-15
------------------------------------------------------	------

CHAPTER III.

WATERWORKS PUMPING ENGINES, ROTARY CLASS,	16-37
-----------------------------------------------------	-------

CHAPTER IV.

WATERWORKS PUMPING ENGINES, DIRECT-ACTING DUPLEX CLASS,	38-51
-------------------------------------------------------------------	-------

CHAPTER V.

DIFFERENTIAL NON-ROTATIVE PUMPING ENGINES,	52-60
------------------------------------------------------	-------

CHAPTER VI.

MINE PUMPS, FORCE PUMPS, AND SINKING PUMPS,	61-74
-------------------------------------------------------	-------

CHAPTER VII.

SUCTION AND DELIVERY VALVES,	75-83
----------------------------------------	-------

CHAPTER VIII.

BORING APPLIANCES FOR ARTESIAN TUBE WELLS,	84-94
------------------------------------------------------	-------

CHAPTER IX.

ARTESIAN WELL OR BOREHOLE PLUNGER AND AIR-LIFT PUMPS,	95-120
-----------------------------------------------------------------	--------

CHAPTER X.

APPLIANCES FOR RAISING PETROLEUM FROM ARTESIAN OR BOREHOLE WELLS,	121-136
-----------------------------------------------------------------------------	---------

CHAPTER XI.

BOILER-FEED AND GENERAL SERVICE PLUNGER PUMPS,	137-181
----------------------------------------------------------	---------

CHAPTER XII.

INJECTORS, JET PUMPS, AND EJECTORS,	182-208
-----------------------------------------------	---------

CONTENTS.

	PAGES
CHAPTER XIII.	
VACUUM AND CONDENSER PUMPS,	209-234
CHAPTER XIV.	
HYDRAULIC POWER PUMPS, RAM PUMPS, AND STEAM, AIR, AND GAS-POWER DISPLACEMENT PUMPS,	235-266
CHAPTER XV.	
FIRE PUMPS AND HIGH-SPEED PLUNGER PUMPS,	267-299
CHAPTER XVI.	
VARIABLE-DELIVERY PUMPS AND VARIABLE TRANSMISSION BY HYDRAULIC POWER,	300-325
CHAPTER XVII.	
MASSE-CUITE, ROTARY, OSCILLATING, AND WIND-POWER PUMPS,	326-356
CHAPTER XVIII.	
LOW-LIFT AND HIGH-LIFT CENTRIFUGAL PUMPS,	357-398
CHAPTER XIX	
WATER WHEELS AND HYDRAULIC TURBINES,	399-460
APPENDIX,	461-462
INDEX,	463-475

LIST OF ILLUSTRATIONS.

BEAM-CONNECTED NON-ROTATIVE STEAM PUMPING ENGINES.

FIG.		PAGE
1.	Section showing earliest type of,	6
2.	„ details of steam and injection valve gears used in,	7
3.	„ improved form of,	8
4.	„ , with enclosed cylinder and separate condenser,	9
5.	„ early forms of compound cylinders,	10
6.	„ , with single-acting 3-valve steam-jacketed cylinder,	11
7.	Elevations showing comparative space occupied by beam- and direct-connected engines,	13
8.	„ compound and most modern type of,	14

ROTATORY WATERWORKS ENGINES.

9.	Balanced-action triple-expansion deep-level,	18
10.	Compound beam, with high- and low-lift pumps,	20
11.	„ with two single-acting ram-plunger high-lift pumps,	21
12.	Geared compound, Elevation of,	23
13.	„ plan view,	24
14.	Three-crank triple-expansion, Photo-view of,	25
15.	„ „ Cross-section of,	26
15a.	„ „ with separate sets of high- and low-service ram plungers,	27
16.	„ „ with double-acting high-lift pumps,	30
17.	„ „ with single-acting ram-plunger pumps,	31
17a.	„ „ Photo of,	32
18.	„ „ with single-acting ram-plunger pumps,	35
19.	Duplex beam-connected,	36
20.	Three-cylinder beam, for town drainage,	37

DUPLEX WATERWORKS ENGINES.

21.	Section showing compound horizontal, with hydraulic compensators,	39
22.	„ triple-expansion vertical, with four single-acting pumps,	42
24, 25.	„ „ with hydraulic-balancing plungers,	46, 47
26.	„ compound, with air-spring compensators,	49

DIFFERENTIAL PUMPING ENGINES.

28.	Section showing valve gear for,	54
29.	„ compound cylinders and action of the valve-gear of,	56
31.	„ triple-expansion, for Artesian well,	59

MINE PUMPS.

32.	Typical deep-level,	62
33.	Hollow-ram,	63
215-217.	Direct-coupled electrically-driven 3-throw,	290-293

		FORCE PUMPS.	
FIG.			PAGE
34.	Typical plunger and bucket,		64
35.	Double-acting ram,		65
36.	Three-throw deep-level, without foot valves,		66

SINKING PUMPS.

37.	Ram and plunger action direct-connected,	69
38.	Double-acting ram plunger direct-connected,	69
39.	Gear-driven,	71
40.	Turbine,	71
41.	Pulsator, with ball valve,	72
42.	„ with clapper valve,	73
186.	„ with saddle valve,	249

SUCTION AND DELIVERY VALVES.

43.	Quadruple-seated ring,	75
44.	Triple-tier beehive,	75
45.	Metal-backed rubber flap,	76
46.	Spring-seated copper flap,	76
213.	„ „ „ „	288
47.	Multiple gill pyramidal, metal ring,	77
48.	„ disc „	77
49.	„ mitre „	78
50.	„ hinged „	78
51.	„ gill „ rubber,	79
52.	Butterfly leather flap,	79
53.	Mitre, Common form of,	80
54.	Double-seated ring,	80
62.	„ „ for borehole pump,	96
55.	Grid, Common form of,	81
163.	„ for vacuum pump,	221
201.	„ for fire pump,	273
56.	Composite disc, waterworks type,	81
212.	Conical rubber composition plug,	287
162.	Part mechanically operated for vacuum pump,	220
168.	„ „ „ „	285
205.	Mechanically operated grid slide, for high-speed pump,	277
206.	„ poppet, for high-speed pump,	280
208.	„ „ „ „	282

BORING APPLIANCES FOR TUBE WELLS.

57.	Steam percussion, with pole and trestle action,	86
58.	Belt-driven percussion, with beam action,	87
59.	„ „ „ „	88
60.	Steam-driven percussion, with jumping actior,	90
61.	Rotary percussion, with abrasive action,	92

BOREHOLE PLUNGER PUMPS.

62.	Section showing, with double-seated valves,	96
63.	„ „ gas-driven, with counterpoise crank balancing gear,	98
64.	„ „ beam-connected, with counterpoise,	99
64.	„ „ sections of suction level balancing action for pump without foot valve,	99
65.	„ „ details of ram plunger used in double-acting balanced-action,	100
66.	„ „ „ with removable barrel,	100
67.	„ „ double plunger, with multiple valves,	102
68.	„ „ steam-driven balanced-action,	102
69.	„ „ details of plunger and plunger connections of double-acting,	104
70.	„ of Artesian well, showing direct-acting steam pump,	105
72.	„ of double-acting single plunger,	108

LIST OF ILLUSTRATIONS.

xiii

AIR-LIFT PUMPS.

FIG.		PAGE
73.	Section of well, showing steam-driven, with concentric tubes,	112
74.	“ “ “ “ with air and water tubes side-by-side,	113
75.	“ “ “ “ electrically-driven,	114
76.	“ “ “ “ steam-driven waterworks,	116
77.	“ of, with taper tube uptake,	130
83.	“ and arrangement of, for oil well,	130

APPLIANCES FOR RAISING PETROLEUM FROM DEEP WELLS.

78.	Arrangement of multiple plunger pump actuating gear,	122
79	“ “ derrick and winding gear for baler pump,	123
80.	Section of oil well with baler pump,	125
81.	“ of air-displacement pump,	126
82.	“ “ “ with automatic float distributor,	127
83.	“ and arrangement of air-lift pump,	130
84.	“ of endless band pump, belt driven,	134
85.	“ “ “ electrically driven,	135

DIRECT-ACTING SIMPLEX PUMPS.

29	Section of steam, with cataract-controlled telemotor operated distribution,	56
86.	“ “ with combined gear and shuttle-controlled distribution, by slide valve,	140
87.	“ “ “ “ “ “ “ “ “ “	140
90.	“ “ “ “ “ “ “ “ “ “	144
97.	“ “ “ “ “ “ “ “ “ “	151
98.	“ “ “ “ “ “ “ “ “ “	152
106.	“ “ “ “ “ “ “ “ “ “	161
96.	“ “ “ “ “ “ “ “ “ “ by piston valve,	150
88.	“ “ with gear-controlled pilot and shuttle-operated, main slide valve,	141
91.	“ “ “ “ “ “ “ “ “ “	145
101.	“ “ “ “ “ “ “ “ “ “	156
107.	“ “ “ “ “ “ “ “ “ “	162
94.	“ “ “ “ “ “ “ “ “ “ Corliss valve,	149
95.	“ “ “ “ “ “ “ “ “ “	149
99.	“ “ “ “ “ “ “ “ “ “ piston valve,	155
100.	“ “ “ “ “ “ “ “ “ “	155
89.	“ “ with all gear-controlled distribution, by slide valve,	142
89a.	“ “ “ “ “ “ “ “ “ “ by Corliss valve,	142
98a.	“ “ “ “ “ “ “ “ “ “ by oscillating valve,	153
92.	“ “ with tappet-controlled, shuttle-operated, slide valve distribution,	146
93.	“ “ “ “ “ “ “ “ “ “	147
104.	“ “ “ “ “ “ “ “ “ “	160
38.	“ “ with main piston controlled, shuttle-operated, piston valve distribution,	69
108.	“ “ “ “ “ “ “ “ “ “	164
102.	“ “ “ “ “ “ “ “ “ “ slide valve distribution,	158
176.	Section of hydraulic, with gear-controlled pilot, and shuttle-operated poppet valve distribution,	237
177.	“ “ with details of distributing valves,	237
179.	“ “ with tappet and shuttle-operated piston valve distribution,	240

DIRECT-ACTING DUPLEX PUMPS.

21.	Section of compound, with balanced action cross-over connected slide valves, and Corliss cut-off valves, with hydraulic compensator plungers,	39
22.	Elevation of six-cylinder pair of vertical beam-connected, with Corliss distribution,	42
24, 25.	Sections of six-cylinder vertical, with Corliss distribution and hydraulic-balancing plungers,	46, 47

FIG.	PAGE
26. Section of four-cylinder, with slide-valve distribution and air-pressure compensator,	49
109. " two-cylinder, with cross-over connected slide-valve distribution, . . .	166
110, 110a. Sections of two-cylinder, with piston-controlled cross-over distribution,	167, 168
111. Elevation and plan of two-cylinder, with part cross-over and part direct-connected slide-valve distribution,	170
112. Sections of two-cylinder, with part oscillating and part reciprocating single valve,	171
113, 117. " four-cylinder, with cross-over connected piston valves,	172, 175
114. " " " " " slide valves,	174
115. " water-end of, with inside packed ram plungers,	174
116. Section of water-end of, with water-sealed inside-packed plungers,	175

FLYWHEEL PUMPS.

118. Sections of three-crank steam-driven,	176
119. " two-crank steam-driven,	177
195, 196. " " " " " fire,	267, 268
121, 121a. " triple eccentric belt-driven,	178
122. " two-crank belt-driven,	179
123. " single-crank belt-driven,	180
206-211. " " " " " high-speed,	280-286
120. " water-end of double-acting,	177
123a. " " " " " diaphragm,	180

INJECTORS.

124. Section of, with plug-controlled sliding nozzle,	183
126, 127. Section of, with plug-controlled sliding nozzle, and single movement,	187
128, 129. Section of, with fixed nozzle, and synchronous-action regulating valves,	188, 189
130, 139. Section of, with split combining cone,	189, 197, 198
131, 136-138. Section of, known as restarting single-tube,	190, 195, 196
132, 133, 134. Section of, known as combined lifter and forcer,	192-194
139, 140. Section of, known as compound,	139, 140
141, 142. Section of, for exhaust steam, only,	200
143. Section showing simple form of,	201
144. " " " " " for bilge-water ejector,	203

EJECTOR CONDENSERS.

145-148. Sections showing typical forms of,	204-206
149-151. " " " " " barometrical,	206-208

CONDENSER VACUUM PLUNGER PUMPS.

152, 153, 155, 158, 160. Sections of jet,	210, 212, 214, 217, 219
152, 154. Sections of three-valve double-stage,	210, 213
169. Sections of three-valve triple-stage,	226
155, 167. Sections of bucket piston, without foot valves,	214, 225
156, 157, 160, 162. Sections of single-acting single-stage, without foot valves,	215, 217, 219, 220
158, 159, 161. Sections of double-acting single-stage, without foot valves,	217, 218, 220
165, 166. Sections of single-acting single-stage, without either head or foot valves,	223, 224
164. Sections of single-acting double-stage, without either head or foot valves,	222
167, 168. Sections of combined dry and wet single-stage,	225
169. Sections of combined dry and wet triple-stage,	226

CONDENSER VACUUM ROTARY PUMPS.

170-175. Sections showing typical examples of,	228-234
----------------------------------------------------------	---------

LIST OF ILLUSTRATIONS.

xv

HYDRAULIC MOMENTUM PUMPS.

FIG.	PAGE
180-184. Sections showing typical examples of,	242-246

STEAM-DISPLACEMENT OR PULSATOR PUMPS.

185, 188. Sections of single chamber,	249, 253
41, 42, 186. Sections of double chamber,	72, 73, 249

COMPRESSED-AIR DISPLACEMENT PUMPS.

81, 82. Section of, for raising petroleum,	126, 127
187. " for sewage and other effluent matter,	251
189. " twin, for lifting water,	254
190. " hydraulic-operated pressure distributor for same,	256

GAS-DISPLACEMENT PUMPS.

191-194b. Sections showing typical examples of,	258-265
-----------------------------------------------------------	---------

FIRE ENGINES AND PUMPS.

195-197. Sections of typical steam, crank-controlled,	267, 269
198. " " petrol-driven,	271-275

HIGH-SPEED PLUNGER PUMPS.

205. Section of, with multiple-ported slide valves for suction and delivery,	277
206-211. Sections and elevations of, with mechanically-closed multiple-ported lift valves,	280-286
212. Section of, utilising momentum effect of the water column for opening and closing the valves,	287
214. " with multiple-ported spring flap valves, for waterworks,	288
215-217. " " " " for mine,	290-292

GAS POWER PLUNGER PUMPS.

218. Section showing four-cylinder double-acting gas engine direct connected to double-acting two-throw piston pump,	295
219. " " single-cylinder double-acting gas engine direct connected to double-acting ram-plunger pump,	296
220. " " single-cylinder gas engine gear connected to three-throw pump,	298

VARIABLE-DELIVERY CONSTANT-SPEED PUMPS.

221, 227. Sections showing methods for obtaining, by a variable stroke,	301-312
229. " " " " by valve control,	315
230, 231. " " " " by differential control,	317, 318
224, 232. " " " " by varying the centre of revolving barrels,	306, 322

HYDRAULIC TRANSMITTERS.

225. Section showing radial pump combined with revolving cylinder motor,	308
232. " " reversible action pump or motor,	322
233. " " turbine pump combined with reversible turbine motor,	324
249. " " rotary pump combined with reversible rotary motor,	341

FIG.	PUMPS FOR THICK AND CORROSIVE LIQUIDS.	PAGE
90a, 108a.	Section showing direct-acting,	144, 165
123a.	" " " belt-driven diaphragm,	180
234, 235.	" " " " with plunger-controlled inlet,	326, 327
236.	Elevation showing, with endless chain,	328
237, 238.	Sections showing, with helicoidal action,	328, 329
239, 240.	Elevation showing, with rotary action,	330

ROTARY PUMPS.

237, 238.	Sections showing typical Archimedean,	328-329
239, 240, 244, 244a.	Sections showing typical, having one displacer drum and one control drum,	330, 334, 336
241-244.	Sections showing typical, having two displacer drums,	331-334
245, 246.	" " " " gear wheel,	337
247, 248.	" " " " " having sliding vane displacers,	339, 340
252.	" " " " " with roller displacers,	344
251-253.	" " " " " with hinged displacers,	344, 345
250, 251.	" " " " " with shuttle displacers,	343, 344
254.	" " " " " with eccentric displacers,	346
255.	" " " " " with plunger displacers,	347
261.	" " " " " typical scoop wheel,	357

MANUAL POWER OSCILLATING, DIAPHRAGM, AND WIND POWER PUMPS.

256.	Section showing quadruple-action wing,	348
257.	" " " " double-acting wing,	349
257.	" " " " " piston,	349
258.	" " " " " triple-action piston,	349
259.	" " " " " single-acting diaphragm,	350
260.	" " " " " details of driving gear of double-acting wind pump,	355

LOW-LIFT CENTRIFUGAL PUMPS.

262.	Section of steam-driven vertical irrigation,	359
269.	" " " " " electrically-driven vertical drainage,	366
275.	" " " " " vertical, with guide ring,	373
263.	Elevation of steam-driven reclamation,	361
264.	" " " " " belt-driven irrigation,	362
267.	" " " " " steam-driven graving dock,	364
268.	" " " " " electrically-driven drainage,	365
270.	Sections of belt-driven dredging,	368
271, 272.	Elevation and plan of dredging steamer,	369, 370
259, 266, 267, 270, 273, 274, 275	Sections showing various forms of impellers used in,	359, 363, 364, 368, 371, 373
282, 283.	Arrangements showing methods for priming,	382, 383

HIGH-LIFT CENTRIFUGAL PUMPS.

279.	Section showing single-stage, with guide ring,	379
281.	" " " " " " rings and twin impellers,	381
280.	Elevation showing single-stage, without guide ring,	380
284.	Sections showing multi-stage, with separately balanced double-eye impellers and guide rings,	385
285.	" " " " " " with disc valve to take up end balance,	387
287, 288.	" " " " " " with double set of impellers to take up end balance,	389, 390

LIST OF ILLUSTRATIONS.

xvii

FIG.	PAGE
289. Sections showing multi-stage, with separate balancing pistons,	391
291. " " " with balancing piston at suction end,	393
295. " " " with balancing piston at pressure end,	398
293. " " " with thrust bearing to take up end pressure,	395
283, 289a. Arrangements showing methods for priming,	383, 392

WATER-WHEELS.

296. Diagrammatic sections showing overshot, breast, and undershot,	400
-------------------------------------------------------------------------------	-----

HYDRAULIC TURBINES.

297, 298. Diagrammatic sections showing various types of,	403, 406
300. Elevation of vortex,	408
301. Sections of vortex,	409
302. " " diagonal-flow,	411
303. Arrangement of diagonal-flow,	412
306. " " mixed-flow, to replace water-wheel,	415
307. " " " for small generating station,	416
309. " " " with cylindrical gate control,	419
308. Plan views of mixed-flow, with a combination of fixed with movable guide blades,	417
310. Elevation of mixed-flow, with sliding cylindrical sluice gates,	420
311, 312. Sectional elevations of radial-axial-inflow horizontal, with movable guide blades,	421, 422
313. Sectional details of guide and impeller blades,	423
314. Elevation of same, showing arrangement of pressure-relay governor,	424
315, 316. " " and plan of single-wheel radial-axial-inflow, with movable guide blades and balancing piston,	425, 426
317. Sectional details of movable guide blades,	427
318. " " elevation of twin inward-flow horizontal,	428
320. Elevation of double-wheel inward-flow, with one vortex chamber and two discharge tubes,	430
321. Part sectional elevations of mixed-flow central discharge horizontal,	431
322. Cross-section of twin inward-flow vertical, with cylindrical gate control,	432
323. Arrangement of pair of same,	433
324. Section of single-wheel inward-flow vertical, with cylindrical gate control and balancing piston,	434
326. Arrangement of an installation of ten of same,	436
327. " " an installation of ten outward-flow,	438
328. Sections showing details of lower impeller and guide ring of same,	439
330. " " " single-wheel outward-flow,	442
331. " " " various sizes of multiple-jet outward-flow,	443
332. Elevation of double-jet outflow,	444
335. Sectional elevation and plan of double-wheel impulse,	448
339. Elevation and plan of impulse, used for centrifugal dehydrators,	452

IMPELLER WHEELS USED IN HYDRAULIC TURBINES.

297, 298. Diagrammatic sections of various types of,	403, 406
299. Elevation of vortex,	408
305. " " radial-axial or mixed-flow,	414
332. " " multiple-jet outflow,	444
333. " " impulse or jet-action,	445
334. " " buckets for same,	446

AUTOMATIC GOVERNORS AND SPEED REGULATORS USED IN HYDRAULIC TURBINES.

304, 325. Cross-section and plan of oil-pressure relay,	413, 435
318, 335, 337, 338, 341. Sectional elevation of water-pressure relay,	427, 448, 450, 451, 454
329, 344. Sectional elevation of ratchet-action relay,	440, 457
342. " " frictional effect relay,	455

FIG.	PAGE
343. Elevation of frictional-effect relay,	456
339, 345. " float-action relay,	452, 458
300, 301, 310, 331, 340. Sections showing hand-controlled speed regulators,	408, 409, 420, 443, 453

METHODS FOR PREVENTING HYDRAULIC CONCUSSION IN LONG PIPE LINES.

335, 336. Section illustrating, by synchronously opening a relief valve,	448, 449
341. " " by a deflecting hood,	454

CONSTRUCTIONAL DIAGRAMS.

28. Illustrating action of differential valve gear for simplex pumping engine,	54
30. " balancing action of differential pumping engine,	57
276. " vane curvature in centrifugal pump impeller,	377
297, 298. " vane curvature in hydraulic turbines,	403, 406

PRESSURE AND EFFICIENCY DIAGRAMS.

23. Illustrating action of hydraulic compensator in duplex pumps,	44
27. " " air-spring compensator in duplex pumps,	50
71. " " direct-acting borehole pump,	106
125. " " boiler-feed injectors,	184
228. " efficiency of variable-delivery pump,	313
265. " " centrifugal pump at constant speed,	362
277. " " centrifugal pump under throttled control,	378
278. " " self-regulating centrifugal pump,	379
286, 290, 292, 294. Illustrating action of multi-stage centrifugal pumps,	388, 392, 394, 396

THE
UNIVERSITY OF
CALIFORNIA

MODERN PUMPING

AND

HYDRAULIC MACHINERY.

CHAPTER I.

INTRODUCTORY REMARKS.

WATER has always been regarded as the first necessity of life, and any means that can be employed for raising and distributing it must rank as one of the most important considerations for communal or urban existence, there being very few cities indeed so favourably situated as to be able altogether to dispense with all such assistance, and there certainly is no form of motive power entirely independent of pumps. Recognising this, it is extremely difficult to realise how people of, say, quite recent times managed to get through life as well as they did without the many conveniences and comforts we moderns derive from the use of pumping machinery in one form or another, recognising that their knowledge of mechanics was a very little higher than that known to the ancients, who, there is good reason to believe, were undoubtedly acquainted with several mechanical devices for raising water, it being only necessary, for instance, to go as far as the British Museum to find some proof of this, where may be inspected, in a condition of remarkably good preservation, a double-barrel pump with bucket plungers and clack foot valves. The origin of which particular "find" is supposed to date back some 3,000 years or so, yet from its appearance, which affords evidence of skilful construction and scientific design, one would gather that the art of raising water by mechanical means was well known at that distant time. Scoop-wheels, too, are supposed to have been used by the Chinese for irrigation purposes at a very remote period, and indeed we have actual record of the use of the inclined Archimedean pump in Egypt before Hero's time, who describes in his work on pneumatics the effect of a vacuum, the construction and effects of various syphons, valves, etc.; a fire engine is also described by this philosopher, constructed with two cylinders having pistons whose rods were attached to a rocking beam. Hero also ascribes the credit to Ctesibus, to whom he was indebted for most of his knowledge of mechanics, for having made the discovery that the atmosphere had weight, and at a time, be it known, right back in the middle of the third century B.C.

The earliest method for raising water mechanically was probably an adaptation of the winch and bucket, apparatus of this kind having been in use from

quite prehistoric times down to the last century. Another adaptation of the bucket pump of Egyptian origin is the balanced pole dipper, and was largely used for irrigation purposes, the use of a balanced pole enabling the water raised to be delivered at any desired angle from the source of supply. The first pump capable of continuous action was probably worked by an endless chain or a rope carrying a series of cups or buckets, a form of pump still in use for raising semi-fluid or viscous substances.

The most notable improvement in the bucket pump was the addition of a filling valve, this being the first known application of a valve for any purpose whatsoever, and constitutes a form of pump known as a "baler," and now used for raising oil from deep wells.

The earliest form of lift pump with bucket-piston caused to reciprocate in a barrel was probably made in wood, an elm trunk properly seasoned and soaked in oil having been generally used for this purpose, owing to its durability. The improved form of lift pump with lead barrel, and wood sucker or bucket, fitted with a leather packing ring and flap-valve was first used for draining mines, the rising main being constructed out of elm trunks bored and coned together, from which practice is derived—in mine parlance—the term "pumptrees" to denote the rising mains or uptakes; the same material was also in general use for town distributing mains down to the seventies of the last century. Therefore, it will be seen that before the advent of steam power, bucket-piston lift pumps actuated by water wheels and animal power were in extensive use; also, that scoop-wheel, chain and screw pumps worked by wind power were in common use for draining the lowlands of Anglia, Holland, and elsewhere, and also for irrigation purposes; but the greatest incentive towards the discovery and development of another and better form of motive power engine was primarily due to the increasing need for a more efficient means for raising water from mines, a purpose that, owing to the comparatively high lifts necessary, required a proportionately greater power.

To such an extent, following the advent of steam power, has this development proceeded, that if all the various hydraulic appliances that have been devised for lifting and forcing water, as well as for generating and transmitting power therefrom, were recorded, it would be truly amazing and probably serve but an incommensurate purpose, as may be gathered from the eighteen following chapters—limited to the description of modern pumping and hydraulic machinery—the number and variety of appliances included would seem to be sufficient or even to exceed many of the requirements of the world for some time to come.

Water being incompressible and of considerable density, as well as possessing the lowest viscosity of any liquid of equal weight, is peculiarly adapted for many purposes other than the more pressing needs of life, such as producing and transmitting great pressures; but its greatest effect, it must be admitted, is produced from the force of gravitation combined with its other attributes, as it can be applied to generate power in such magnitude that if all the "Falls" of the world were fully utilised for this purpose, the power so generated would more than equal the combined effect of all the motive engines now deriving their forty million or so of indicated horse-power from the combustion of fuel; and although only about two million horse-power is at the present time generated by this means, it affords sufficient evidence that hydraulic power is destined to have in the near future a tremendous influence on the prosperity of manufacturing districts, bearing in mind that, whereas the generation of power by the consumption of fuel, which is going on at the rate of more than one

million tons for each day, since the process of combustion is not reversible must consequently result in a total loss to the world's fuel-power resources. Every ton of fuel once burned is irretrievably lost, and considering that at the present time that the consumption of fuel for the immediate purposes of power does not fall far short of 400,000,000 tons every year, there must be a time—and not so very distant either—when water power will have to be much more extensively utilised than now, recognising that it possesses the inestimable advantage over every kind of fuel power in having a complete cycle provided by nature in perpetuity.

CHAPTER II.

EARLY DIRECT-ACTING STEAM PUMPING ENGINES.

THE first application of steam power as a pumping engine was made by the Marquis of Worcester in 1663, who improved upon the ideas of one Solomon de Claus, a French engineer, Worcester having visited this misunderstood inventor in an asylum, where he was incarcerated as an impostor for importuning his betters and proclaiming too loudly the many advantages his country would derive in adopting his invention. Although far from the purpose of this chapter to describe with any approach to detail the various stages in the evolution of the power-driven pumping engine, yet an outline description of a few of the most prominent inventions made in connection with pioneer attempts to raise water by other and cheaper means than that known at that time will be of some interest.

The Worcester pumping engine consisted essentially of two principal elements—*i.e.*, the steam generator and a closed water chamber, the latter being located at a point below the water to be raised. The *modus operandi* of this engine, which can be explained without drawings, was to first fill this chamber with water by means of an inlet pipe provided for the purpose, when steam from the generator was admitted so as to be able to press on the surface of the water in this closed chamber, the water being thus forced out through an uptake pipe communicating at its lower end at a point near the bottom of the water chamber. In some of these engines two water chambers were used, each provided with a clack non-return valve and delivery pipe, which communicated with a water tank situated at a height at which water could be thus conveniently raised, the steam pipe from the boiler being connected by branches to each of the "pulsator" chambers, to which were fitted stopcocks that could be opened and closed by hand in an alternate manner, and by this means while one pulsator or water chamber was being emptied the other could be filled. A somewhat identical method for raising water was described by Montgolfier in 1816 for raising water by means of hot air caused to press direct on the surface of water in an enclosed chamber.

The next stage in the development of the pumping engine was Savery's improvement for utilising the force of the atmosphere, an engine on this principle being made in 1698; this differed from the foregoing in being more like the modern pulsometer, and consisted of a steam generator and closed water or pulsator chamber as before, but situated in this case about 20 feet to 28 feet above the surface of the water to be raised, and was connected by a steam pipe and stop cock to the boiler as in Worcester's engine. Savery, however, used a suction pipe provided with a non-return clack valve in addition to the ascension pipe; the action of this pump was as follows: (1) the pulsator chamber was filled with steam; (2) water was introduced in the form of spray for the purpose of condensing the steam and in this manner produce a vacuum; (3) water ascended into the chamber from the source of supply, and when this action ceased steam

was again admitted from the generator on to the surface of the water driven into the chamber by the force of the atmosphere, until (4) the steam pressure had displaced the water in forcing it up through a delivery pipe into a tank or sluice, placed at a height which depended on the pressure available; this never exceeded the distance of the pulsator above the suction supply, but practically doubled the efficiency of the pump as compared with the first attempt. In this connection it may be mentioned that the first description of a pumping engine worked by a vacuum produced by the condensation of the products of combustion of an explosive mixture of gas and air was by Samuel Brown, who between 1823 and 1826 proposed to raise water by this means for the purpose of driving a water-wheel.

The third and most important stage up to this time in the progress of the pumping engine was the application of the cylinder and piston; this appears to have been first suggested by Papin in 1698, who first proposed to use gunpowder behind a piston, and thus produce a vacuum for the purpose of raising water, but later showed the possibility of realising this effect by the use of steam; however, this idea was very soon after adopted by Thos. Newcomen, a Devonshire man, who made his first practical application of this principle from 1705 to 1712. *N.B.*—A working model of an improved Newcomen engine is to be seen at the Patents Museum, South Kensington, which consists of an open-topped cylinder fitted with a hemp-packed piston made as water-tight as its free movement will allow; this piston in the earlier forms communicated its motion by a chain to a quadrant at one end of an overhead beam, the other being utilised to balance the steam piston and to work a pump. This engine worked in the following manner:—Steam was at first admitted to the underside of the piston, which then, by means of the counterweight of the pump mechanism, made its up stroke; then water was sprayed into the cylinder, and thus condensing the steam; thirdly, by the resulting vacuum of from 6 to 9 lbs., the piston was forced down and the pump-bucket raised. Several pumping engines of this type were put down at various collieries up and down the country, and at the tin mines of Cornwall, from the time of its introduction—1705-1712—until as late as 1820, when three engines were put down at Farme Colliery, Rutherglen, near Glasgow—*i.e.*, nearly 60 years after Watt's discovery of the separate condenser. One of these engines was worked for nearly a century, and the other two were only dismantled 26 years ago. The largest had a 60-inch diameter cylinder, with a maximum stroke of 7 feet, and was supplied with steam from two haystack boilers, as shown in Fig. 1, at a pressure from $2\frac{1}{2}$ lbs. to 3 lbs. per square inch, the boilers being 30 feet and 25 feet in length respectively. The piston was packed in the usual way by old hemp-rope, kept in place by heavy iron segments, the piston being water-sealed, as found necessary with all engines of this construction, in order to keep out air from the cylinder. The first "Newcomen" of which there is any record was put down at Dudley Castle in 1712, and water-jacketed for the purpose of condensing the steam for the down stroke, but owing to the slowness of its action was afterwards fitted with a water injection: the second engine, having a cylinder 22 inches diameter, was put down at Nuneaton in 1715. The engine illustrated by Fig. 2 was installed at Caprington Colliery, Ayrshire, in 1806, and was continually in work until 12 years ago pumping from a pit 166 feet deep; the cylinder of this engine was 30 inches in diameter, and had a stroke from 4 feet 6 inches to 5 feet, and a speed of 11 to 12 double strokes per minute, and worked a pump of 9 inches diameter, the water-load being from 8 to 9 lbs. per square inch of the piston area. Another rather interesting instance may be given of one

of these engines which was erected at a colliery belonging to the Ashton Vale Iron Company, Bedminster, near Bristol, in the middle of the last century—viz., 1745—and is, judging from the illustration,* Fig. 2, a very remarkable example of early engineering art, especially as it had continued in almost unbroken service for practically $1\frac{1}{2}$ centuries. This engine had a cylinder 5 feet 6 inches diameter, with a maximum stroke of 8 feet, and was indicated as recently as 1895, at which date it was working with a vacuum of 9 lbs. to 10 lbs. per square inch, and developed 52 I.H.P. in pumping water from a depth of 700 feet in three stages by three pumps each 9 inches diameter.

Various improvements were made from time to time in the detailed construction of these engines; at first they were worked by hand, until by degrees

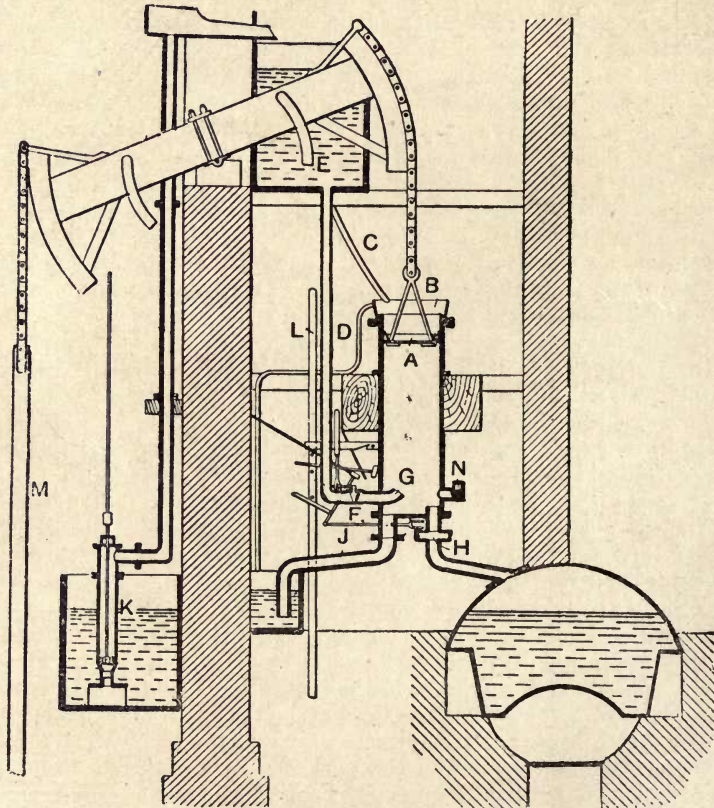

Fig. 1.—Early Type of "Newcomen" Pumping Engine.

A, Piston; B, the cup; C, water supply pipe to top of piston; D, overflow pipe from top of piston; E, injection cistern; F, injection pipe and valve; G, injection; H, regulator valve; J, eduction pipe; K, injection pump; L, plugtree which opens and shuts regulator and injection cocks; M, pump rod; N, snift.

means were discovered for actuating the steam inlet and water-injection valves mechanically. In all the old engines the eduction pipe from the cylinder was arranged with sufficient fall to prevent water from returning to the cylinder

* *Engineering*, October 25, 1895.

from the hot well, later engines being fitted with a short pipe and non-return valve, as shown in Fig. 3. Beighton, of Newcastle, made some considerable improvements in the valve mechanism on an engine put down at Low-Walker in 1718, and Smeaton, who formulated the present pump-duty equivalent, computed the duty of 15 engines in the Newcastle district in 1767, and two years later 18 other engines in Cornwall, and found the average power duty obtained at that time to be 7.4 million foot-lbs. per cwt. of coal; it may be also noted that at this stage eight of these engines had cylinders from 60-inch to 70-inch diameter, and that one "Newcomen" put down in 1775 at Chacewater in Cornwall had a cylinder 72 inches diameter, and showed an efficiency of 11,000,000, working on the old water-injection principle.

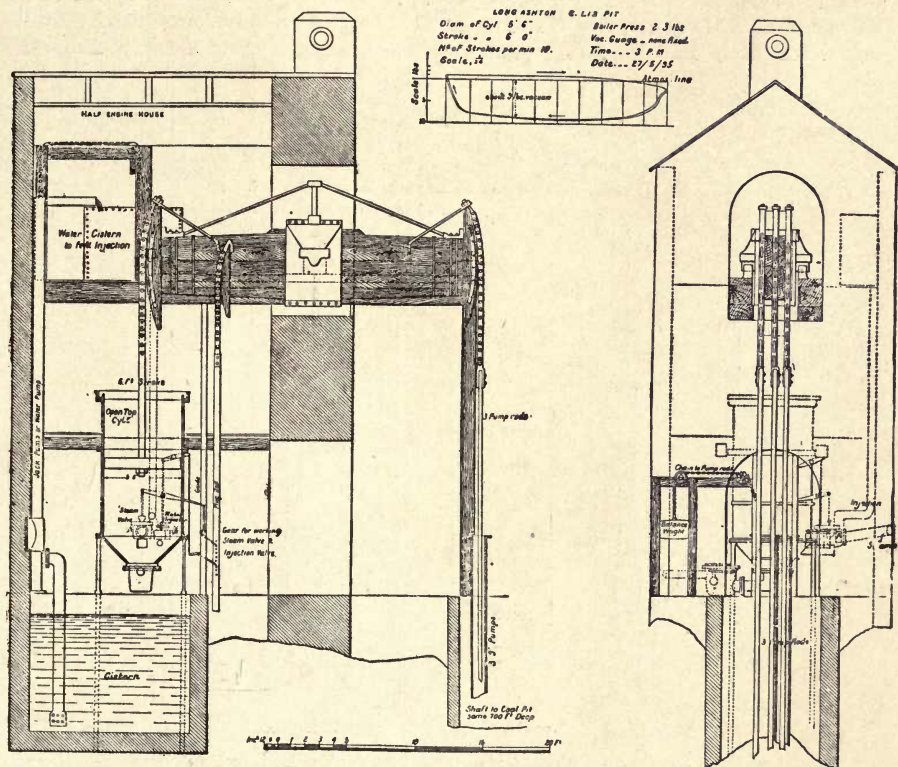

Fig. 2.—Section of Newcomen Pumping Engine, showing Details of Steam and Injection Valve Gear.

Although many detail improvements by Beighton, Potter, Hornblower, Smeaton, and others were introduced in the construction and working of the Newcomen engine, which, by-the-way, continued to be made for nearly a century after its inventor's death, it was destined for James Watt to advance the art of utilising steam power, the greatest step forward; for, like Newcomen, who obtained his first knowledge of the properties of steam while engaged in the construction of a Savery pump at Dartmouth, in 1702 or thereabouts, so, in like manner, did Watt, 60 years later, make his first acquaintance with the steam engine while repairing a Newcomen model. This was in 1763, and resulted

in his discovery of the separate condenser, which by one stride practically doubled the efficiency of the atmospheric steam-pumping engine. Watt realised that the great waste of steam in the Newcomen engine was caused by the condensation of live steam coming into contact with water on the cylinder bottom and the cold walls of the cylinder and piston after each down stroke, and conceived the idea of exhausting the steam into a separate chamber, fitted with a spray injection, and provided with a pump for removing the water and accumulating air.

During 1776-1779 Watt had already installed four of his improved pumping engines in Cornwall, and by 1800 had succeeded in raising the average power duty to nearly 24,000,000, one engine put down at Gwinear, with a 70-inch cylinder, giving a duty of over 30,000,000. A great demand sprang up for this more economical engine, which resulted in 1775 by the Soho Works being established for their manufacture. Although Watt engines gave such a marked

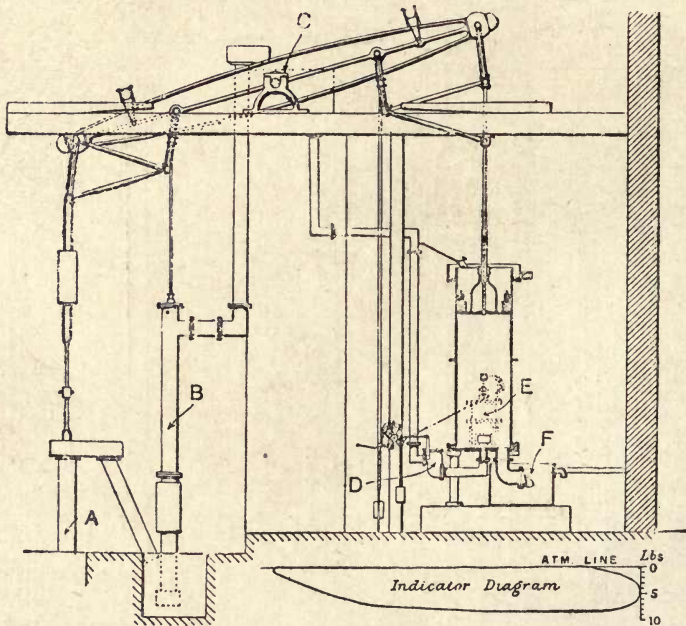

Fig. 3.—Improved Newcomen Engine.

A, Pit pump ; B, jack head pump ; C, injection tank ; D, injection valve ; E, steam valve ; F, hot well.

superiority over the Newcomen engine in economy, which, by-the-way, they very closely resembled, Newcomen engines still continued to be made for many years, and, strange to say, while Watt's first engines were put down in Cornwall, Newcomen's latest engines were installed in Scotland. Other improvements in pumping engines made by Watt were the parallel link-motion, shown on Fig. 3, which superseded the old chain attachments to quadrants, or "horse-heads," at the two ends of the beam, as shown in Figs. 1, 2, and 4, and the closed cylinder.

By thus using a separate condenser, he not only avoided considerable con-

densation on the upstroke, but by excluding air altogether from the cylinder was enabled to obtain a better vacuum on the down stroke, one of the greatest difficulties being experienced in all the early engines in keeping the piston from leaking air to the under-side of the piston. In the cylinder, which was closed at each end, steam was first admitted over the piston at a pressure varying from 3 to 7 lbs, and on the up stroke this steam was transferred to the space under the piston when the communicating valve was closed and another valve to the condenser opened, as shown in Fig. 4.

By this description it will be seen that Watt's single-acting pumping engine with a closed cylinder was the fore-runner of the well-known Cornish beam and

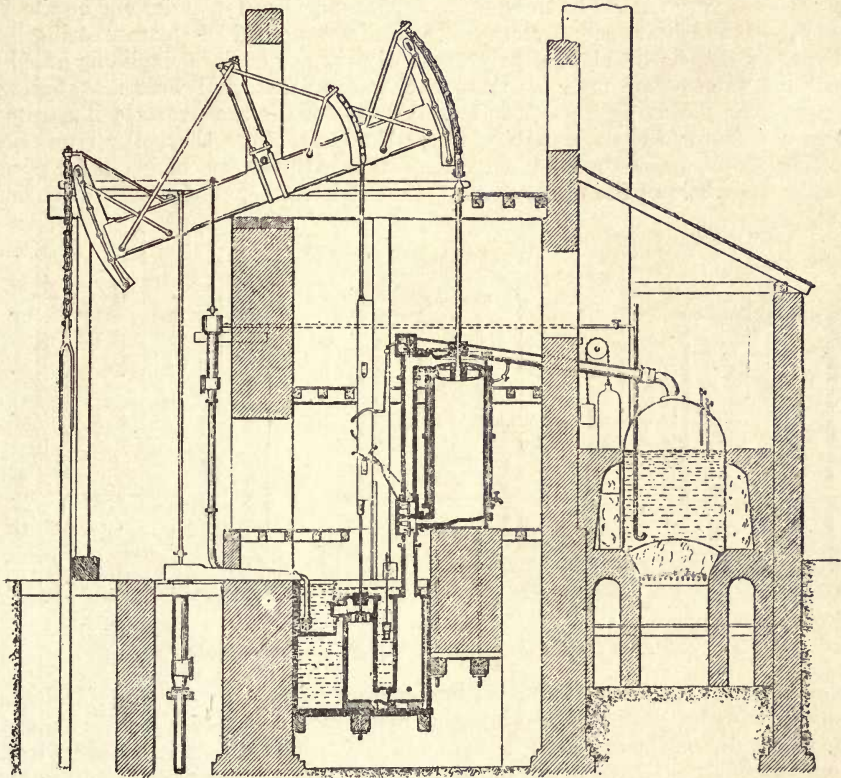

Fig. 4.—Early "Watt" Pumping Engine, with Enclosed Cylinder and Separate Condenser.

Bull engines so extensively used for mining and other purposes during the early part of the nineteenth century.

Watt always remained an advocate for low pressures and opposed the practice of using steam higher than 7 to 10 lbs. per square inch, and it is said his firm even tried to get Parliament to restrict the use of higher pressures than this owing to the danger of bursting the boilers. Trevithick, Hornblower, Sims, Bull, and others were in favour of higher pressures, and the first compound engine on the Woofe system was made by Hornblower in 1781, and later on several variations on the compound principle were tried, but did not develop any striking advantage

in economy, owing to the low pressures used. Three examples of cylinders for compound or double-expansion working are shown in Fig. 5. The outcome of all these experiments was the single-acting three-valve engine shown by Fig. 6. This rather cumbersome and simple type of engine has been put down in great numbers for draining mines, for waterworks, and for reclaiming lowlands. They work to best advantage when employed in operating deep-level pumps, owing to the method adopted of utilising the weight of the pump-rod and plunger to make the water stroke and partly to the design of the steam-jacketed cylinder, and in not exposing the live steam end to the frigorific influence of the condenser. The construction of the cylinder and disposition of valves is very similar to the design of Watt's enclosed cylinder engine shown by Fig. 3, and bears some resemblance to Sims' method of steam distribution shown by Fig. 5; in all the early types of pumping engines single- or double-beat lift valves were used for admission and exhaust, and were actuated by tappet gear shown by Figs. 4 and 6. The piston in the example illustrated is at a point on the down stroke, where the steam from the boiler is usually cut off, the under side being in communication with the jet condenser for practically the whole of the down stroke; thus it is seen that this type of engine

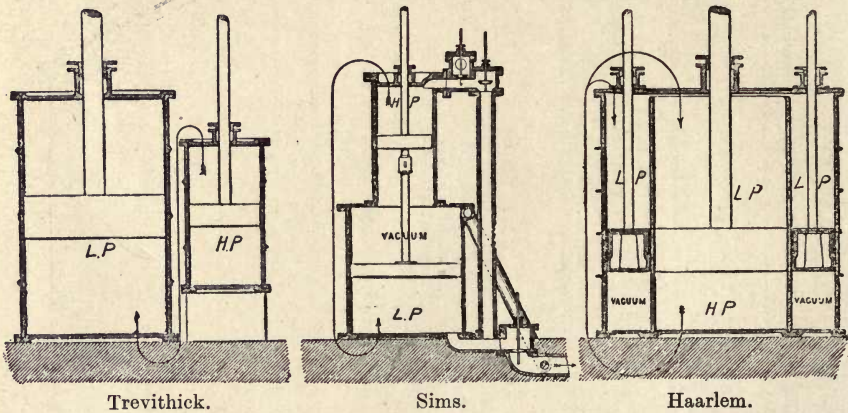

Fig. 5.—Early Types of Compound Cylinders used in Pumping Engines.

relies entirely on the counterpoise effect of its pump-rod and plunger to obtain the up stroke of the steam piston. The cylinder is completely jacketed round the barrel and on the top cover, the jacket space being fed with live steam direct from the boiler; the early cut-off is obtained by a trip-gear easily adjustable to close the steam admission at any point from one-fifth to one-third of the steam stroke, and during the greater part of the up stroke the transfer valve shown in Figs. 4 and 6 is open, thus placing the two sides of the piston in equilibrium, only closing sufficiently early to form a cushion, and thus arrest the motion of the heavy swinging beam used to continue the steam stroke after the early cut-off by its momentum.

The Cornish pumping engine works a pump of the plunger type; consequently the water load is overcome entirely by the counterpoise action of the pump end of the beam. Thus, when these engines are used in waterworks, it is necessary to provide a balancing weight, which is placed directly above the plunger, this counterpoise being filled with lead shot in sufficient quantity to complete the water stroke at the required speed, and varies accordingly to the

water head against which the engine is set to work. One peculiarity in this type of engine is the disparity in the velocity of the down and up strokes, the up stroke of the plunger—*i.e.*, the steam stroke—being usually from 60 to 80 per cent. faster than the down stroke or the water stroke, and for this reason the suction valve is made especially large, and in many cases two suction valves are employed and one delivery valve, each of the multiple-seat type, to be

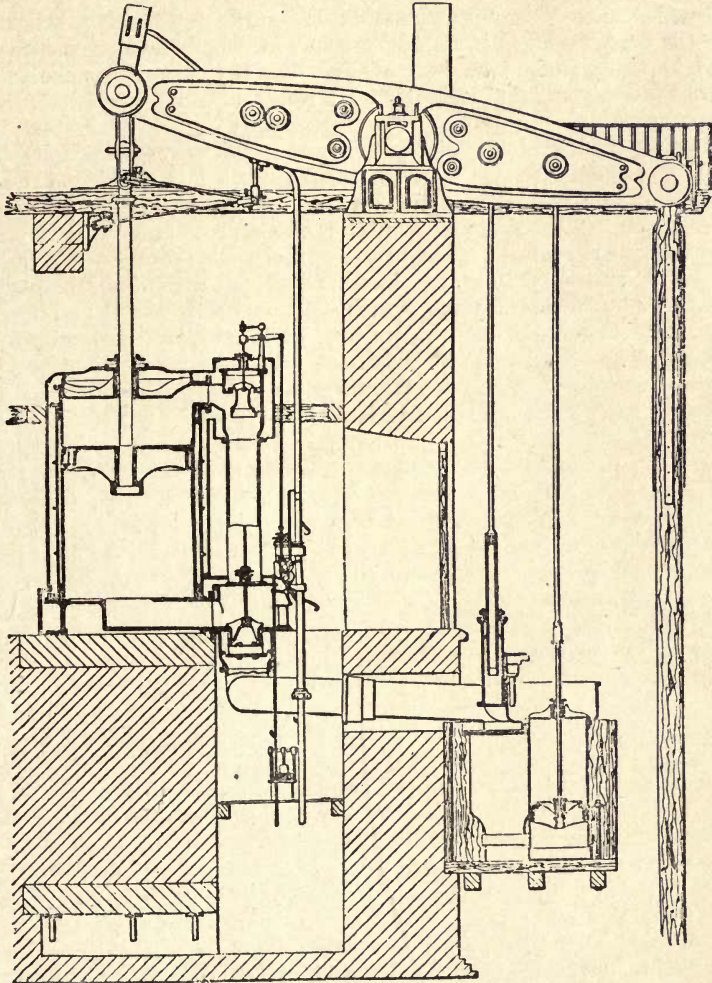

Fig. 6.—Cornish Pumping Engine, with Single-acting Steam-jacketed Cylinder.

described later. Although the steam pressure available for this class of engine is limited to from 40 to 45 lbs. per square inch when one cylinder is used, and the weight of the pump end of the beam found necessary in practice must preponderate by as much as 20 per cent. the resistance of the water load, yet it works with a fairly high economy when properly adjusted to its load, and has been found to be superior in this respect to the early makes of rotative engines,

and was on this account selected in 1840 for the purpose of draining the Haarlem Lake in Holland; three engines, with cylinders 12 feet diameter, and having a piston stroke of 10 feet, being used. These engines were constructed with compound concentrically-arranged cylinders, as shown in Fig. 5, steam being first supplied to the bottom end of the inner cylinder for the up stroke, and on the down stroke this cylinder was placed into communication with the top end of both cylinders, and thus acted equally upon the upper sides of both pistons, which moved together, the space below the outer piston being always open to the condenser. It is stated that an economy of nearly 90,000,000 was obtained in these engines on best Welsh coal, each being capable of lifting 60 tons of water per minute to a height of 15 feet, and worked from 9 to 10 double strokes per minute.

In 1836 the first of a long series of Cornish engines was put down at Old Ford by the East London Water Company, the Vauxhall and Southwark Company alone having more than a dozen engines with cylinders ranging from 36 to 112 inches diameter. The combined capacity of Cornish engines in the various waterworks of this country far exceeded any other type up till 30 years ago. The largest example of this type has been in continuous pumping duty at Battersea for upwards of 60 years, and is still apparently as good as new. This engine has a cylinder 112 inches diameter, while another at Kew Bridge has a cylinder 100 inches diameter, there being some 30 others of various sizes still in use at the several pumping stations under the control of the Metropolitan Water Board, and serve to distribute a large proportion of London's daily supply of 220,000,000 gallons of water, and equivalent to some 33 gallons for each man, woman, and child of this great city. There is no other type of pumping engine that creates such an impression of solidity, and certainly few are more durable, but the percussive shock of such large single-acting plungers on the water mains must be immense whatever the dimensions of the air chambers, there being too long a pause between the successive water strokes for the flow of water through the pipes to be made quite continuous, even with the aid of a hydraulic balancing column some 50 to 70 feet high, which is the method usually adopted with these engines for equalising the flow in town mains. To give some idea of this pulsating action, it must be considered that a 112-inch engine delivers 860 gallons at each water stroke, at a plunger velocity of from 110 to 130 feet per minute; or, in other words, a weight of water of nearly 4 tons is forced into the delivery main at intervals of three seconds. These engines, however, under some circumstances when worked in pairs lend themselves for synchronous action, when, of course, the combined effect of two engines is equivalent to one double-acting pump, provided both are delivering into one main. Although the manufacture of these engines has been discontinued since about 1885, when the latest of this type was put down at the Leicester Waterworks, there is every probability of their remaining in use for many years, and it may be noted in this connection that the Harvey Works, which was principally engaged in their manufacture, as well as the Soho Works, are both now closed.

The Bull pumping engine is of somewhat similar construction to the foregoing, but instead of having an overhead beam, is made direct acting, and is provided with one inverted steam cylinder of the triple-valve balanced type, the piston being directly connected to the bucket plunger of a pump placed below. Several engines of this construction are still to be met with in mines and various pumping stations, all of which are provided with a balancing beam and counterpoise arranged below the steam cylinder, and used for the dual purpose of controlling the velocity of the down stroke and assisting the up

stroke. In this engine (*vide* Fig. 7) the steam and water strokes work together and in this respect is quite the reverse to the action of the beam engine, which, as described, is worked on the water stroke by the deadweight alone of the pump mechanism. In point of economy and working, and in the distribution of steam, they resemble very closely the beam engine shown in Fig. 5, but are not liked so well, although they occupy much less room.

The best results are obtained in pumping engines of the single-acting beam type when working with a correctly adjusted cut-off to suit the exact load, again the velocity of the steam stroke must be high, or the deadweight of the moving parts excessive, and are on this account better adapted for pumping against

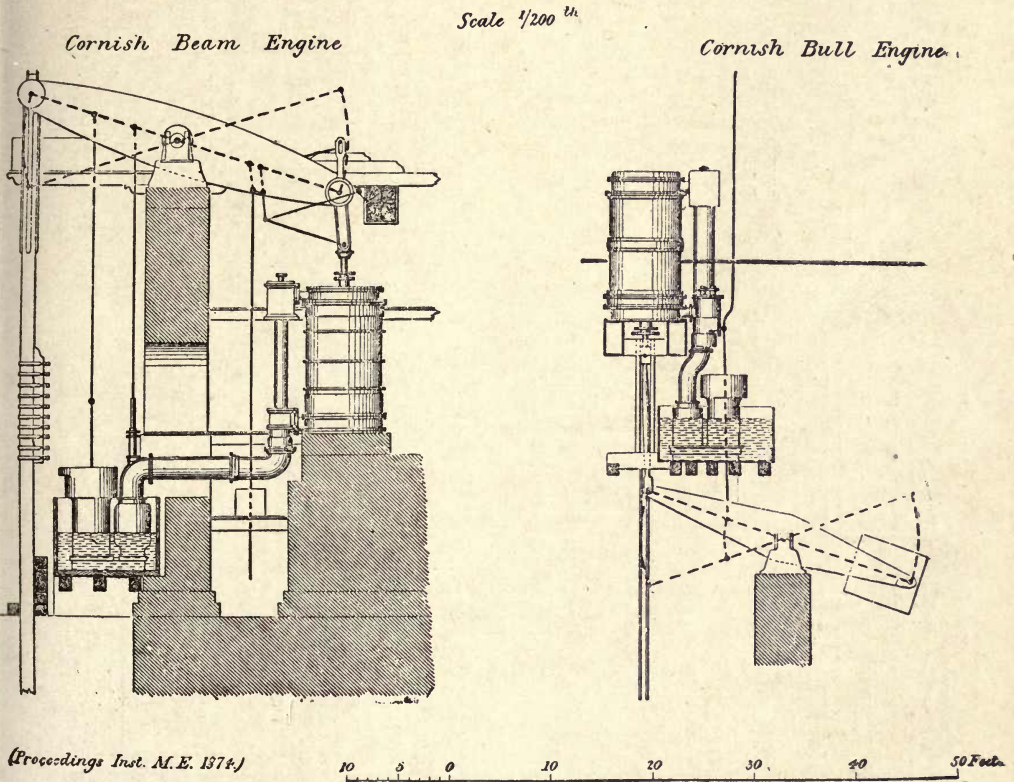

Fig. 7.—Sections showing Comparative Space occupied by Cornish and Bull Direct-acting Pumping Engines.

a constant water head than a variable resistance, as met with in charging town mains for instance; it is, therefore, found that in ordinary working many of these engines scarcely realise so good a result as often anticipated from a trial test under special conditions, and fall in many cases below an average duty of 60,000,000. However, in order to demonstrate the possibility of a higher average working efficiency being obtained, an improved type of engine, constructed on the compound balanced action principle, has been made by Messrs. Hathorn, Davey & Co., of Leeds, from the designs of Mr. Henry Davey, of Westminster. One of these engines was put down at the Basset Mines, Cornwall, in 1890, where

an economy is obtained under every-day working conditions which never falls below 90,000,000, and frequently exceeds a duty of 100,000,000 foot-lbs. per cwt. of ordinary steam coal. In this mine water has to be pumped from a depth of 1,000 feet at a rate of approximately 1,000 gallons per minute.

The general arrangement of the engine differs very materially from the old type with one single-acting cylinder, as will be seen from the illustration (Fig. 8). In this case there are two inverted cylinders, *h*, *l*, placed one at each end of a beam pivoted at the floor level of the engine-room. At the extremity of one end of the beam is pivoted the pump-rod *p*, where it receives a vertical motion of

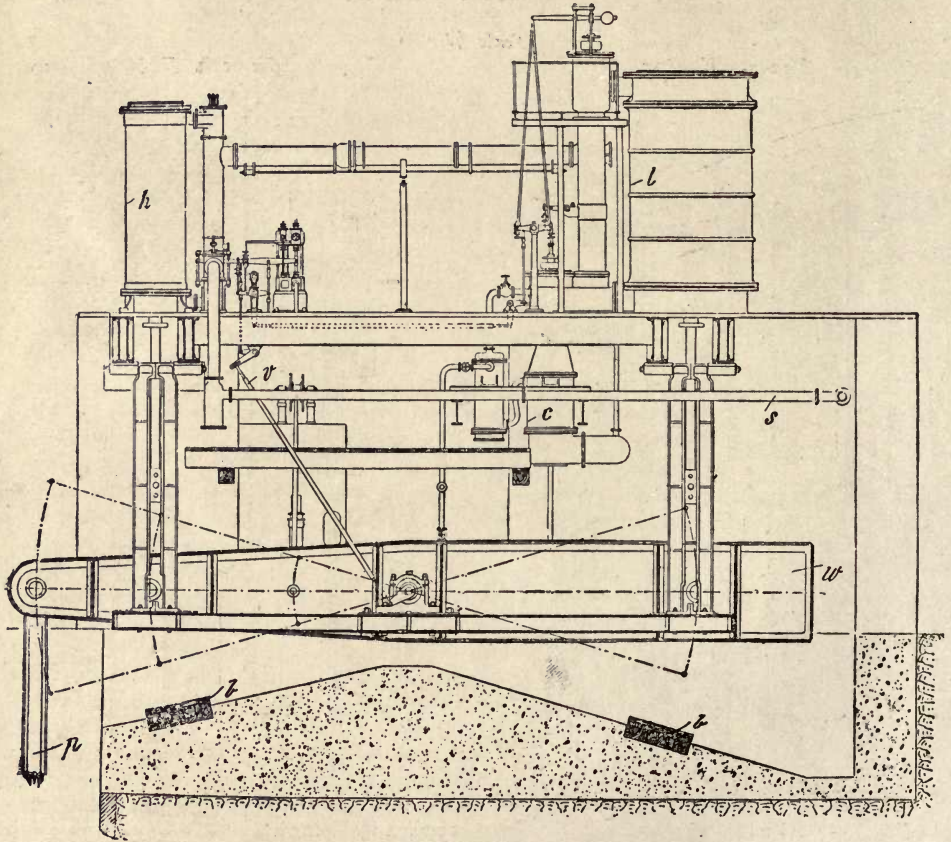

Fig. 8.—Davey Compound Beam Pumping Engine (Cornish Type).

13 feet. At another point closer in towards the centre of the beam is pivoted the connecting-rod of the high-pressure cylinder, which is 40 inches diameter, and receives a motion giving a stroke of 9 feet. At the other end of the beam is pivoted the connecting-rod of the low-pressure cylinder, which is 80 inches diameter, and where it receives a motion giving a stroke of 10 feet, each piston-rod being fitted with a crosshead, working between parallel guides formed in the cylinder columns. The total weight of the two pistons, plunger, beam, and rods is somewhere near 160 tons, which mass swings with a steady motion

each way at from 10 to 12 double strokes per minute. The cylinders are each constructed on the single-acting principle—viz., the high-pressure cylinder receives live steam, acting on the bottom side of the piston during the up stroke of the pump-rod; on the down stroke this steam is transferred to the top side of the high-pressure piston; on the succeeding up stroke of the pump plunger the steam is expanded against the top side of the low-pressure cylinder, whence it is transferred to the bottom side of the low-pressure cylinder on the succeeding down stroke of the pump plunger—i.e., the up stroke of the low-pressure cylinder—and exhausted into the condenser on the following stroke; by this cycle the temperature at each end of the pistons is maintained at a more constant degree than in a double-acting engine, the pressure at the top and bottom of the piston in each cylinder being balanced on alternate strokes, and accordingly both cylinders are single-acting only. Although the power of both cylinders is applied to the two ends of the beam simultaneously, it is necessary for the low-pressure end of the beam to be weighted, *vide w*, to partly counterpoise the long spear-rod *p* and plungers, the total length of the 1,000 feet lift being divided into stages of 200 feet, as in another mine worked under similar conditions, where one of the Davey improved compound single-acting beam engines, having cylinders of 45 and 90 inches, has been installed. In each case steam at 100 lbs. pressure is used, the distribution being by double-beat lift valves, actuated by the maker's "differential controlling gear," to be described later. There are in all five of these valves used—one high-pressure admission and one balancing valve to the high-pressure cylinder, and one admission, one balancing, and one exhaust valve to the low-pressure cylinder.

Another compound engine, of exactly similar type, but of even larger size, has been more recently put down at the Waihi Mines, New Zealand, the particulars of which are as follows:—High-pressure cylinder, 60 inches diameter by 6 feet stroke; low-pressure cylinder, 110 inches diameter by 12 feet stroke; ratio of high pressure to low pressure, 6·7 to 1; range of expansion, 14 times; steam pressure, 150 lbs. per square inch. Plunger ram pumps are arranged 23 inches in diameter by 12 feet stroke in two stages, the first pump being 700 feet from the surface, and are capable of raising 1,500 gallons per minute from a total depth of 1,550 feet at a speed of 7 double strokes per minute, when 730 P.H.P. are developed.

The buffer planks *b b*, placed on the pit floor, are only used for the purpose of arresting the motion of the beam when exceeding the limits of the working stroke, as in starting or in case of failure of the pump attachment. In ordinary working the action of these engines can be easily controlled to within an inch or so of its full stroke, and it will be seen that in applying these various improvements together with the compound principle to this useful and once popular type of mining engine, an advance has been made which may be safely said to have touched high-water mark in the development of the "non-rotative beam" pumping engine.

CHAPTER III.

WATERWORKS PUMPING ENGINES.

Rotatory Class.

ROTATIVE beam pumping engines were first made with single-acting cylinders, a few having been constructed to work on the atmospheric principle with water injection as far back as the latter end of the eighteenth century by the Coalbrookdale Iron Company, where one of these engines was occasionally used until 1879. Although Watt's engine with closed cylinder and separate condenser was so great an improvement on the old Newcomen, yet it was not such a success when applied to the flywheel pumping engine as with engines of the non-rotative beam type; Watt, therefore, on realising that the single-acting engine laboured under a great disadvantage on account of its want of balance and slow action, introduced his double-action engine, by which means he was enabled to dispense with the necessity for using a balance weight for the up stroke. The rotative beam pumping engine from that time has received many improvements, the principal advance consisting in the use of two cylinders arranged to work with double expansion; also a great number of water supply pumping engines have been built with two cylinders variously arranged in combination with an overhead beam and flywheel by the old firm of Boulton & Watt and others; as a notable instance of which may be mentioned a pair of large engines of this type supplied to the Grand Junction Waterworks of the Metropolitan Board, each capable of delivering from 3 to $3\frac{1}{2}$ millions of gallons per 24 hours. In these engines the two cylinders are both situated at one end of the beam, the pump-rod being pivoted at a point outside the crank connecting-rod, the crank having a radius of 3 feet 6 inches; the diameter of the high-pressure cylinder being 29 inches by 5 feet 7 inches stroke, and that of the low-pressure cylinder 48 inches diameter by 8 feet stroke. The pump is of the plunger and bucket pattern, more fully described in Chapter VI., the diameter of the plunger or ram being $21\frac{3}{8}$ inches, and the diameter of the bucket plunger $30\frac{1}{2}$ inches, which is, of course, single acting, while the high-lift end of the pump is double acting. The advantage of this form of pump consists in being double acting at its delivery end, while only requiring one suction valve and one valve in the bucket piston, the valves both being of the double-seated ring type. The diameter of the ram is proportioned to give half the area of the bucket, and it follows that, on the down stroke, one-half of the water transferred from the bottom of the bucket to the space above the piston is displaced by the ram plunger, and thus forced into the delivery main, and on the up stroke of the plunger and bucket the other half of the water above the bucket is lifted into the main by reason of the area of the bucket piston being twice as great as the area of the ram plunger. In combination with deep-level pumping engines this form of pump is often used as a relay to force the water from a sump, where it is lifted by the deep-level pump before being forced into the town-delivery pipes, this method being adopted at the Streatham pumping station, where

the machinery consists of two pairs of geared triple-expansion horizontal engines having cylinders $8\frac{1}{2}$, 13, and 25 inches by 2 feet stroke. These engines each drive separate pump crank shafts through helical steel wheels 8 and 12 feet diameter by 8 inches face, from which are worked two deep-level pumps, situated 140 feet below the surface, and having each a pair of bucket plungers of the concertina type, 15 inches diameter, both buckets having a stroke of 5 feet, thus the effective stroke of each pump is 10 feet; the advantage of this form of pump is the facility of removing the working parts for cleaning or repairs, there being no foot valve or delivery valve other than the valve in each bucket, which are driven by two balancing quadrants, the lower plunger being connected by a rod passing through the upper plunger, which is in turn connected by a tubular rod. These pumps deliver into a sump alongside the engines, whence the water is forced against a head of about 230 feet direct into the town main by a crank-driven differential pump, in which the diameter of bucket plunger is 2 feet 6 inches and the diameter of the ram plunger 1 foot 9 inches, with a stroke of 2 feet 6 inches; and has each a capacity of $1\frac{1}{4}$ millions of gallons per 24 hours when working at their normal speed of 12 revolutions per minute. The valves used in the force pumps are of the ring double-seated type shown by Fig. 54, which in this case are particularly suitable owing to the slow plunger speed of 60 feet per minute. It is noteworthy that the two sets of pumping machinery installed at this station was the last job carried out by the firm of Boulton & Watt, the engines having been running now for about twenty-five years.

In the design and arrangement of this class of engine, when considered apart from the pumps, lowness of first cost as in so many other cases is the predominating factor, the question whether the engine shall be horizontal or vertical being influenced as much by the bias of the designer as by other considerations—such as floor space. When it is necessary to pump the water supply from a deep level, in addition to forcing it into the surface main, the differential non-rotative type of pumping engine is very usually employed, and it is for such cases as this that the quadrant rotatory pumping engine, illustrated by Fig. 9, has been designed. This improved type of engine combines the advantages of the horizontal triple-expansion direct-acting differential with the steadiness of action and economy of the flywheel engine. The particular engine illustrated has been installed at the East Barnet Well. This engine, of which there is a duplicate, is capable of delivering $1\frac{1}{2}$ millions of gallons per 24 hours from a depth of 300 feet in the well, and delivering the same into a reservoir against a surface head of 250 feet. A special feature of these engines is that the whole of the low-lift pump work can be got at and drawn out, without in any way interfering with the engine mechanism. This is accomplished by having the high-pressure and intermediate-pressure cylinders attached to the outer ends of the bell cranks, and thus leaving the inner ends quite free. The engines are designed for a working steam pressure of 150 lbs. per square inch, the whole of the steam cylinders being steam jacketed, while steam-jacketed receivers are also fitted between the cylinders. The valve gear is of the latest type of Corliss trip gear, the trips of the high-pressure cylinder being directly controlled by a very sensitive governor. The low-lift pumps are of the single-acting bucket-plunger type, and deliver through a surface condenser into a tank just below the engine-room floor, from which the high-lift pump draws its water; which latter is a horizontal double-acting plunger pump with externally packed rams and multiple spring-closed valves. From the description it will be seen that this engine is constructed from a very unique design, one, in fact, for which can be claimed some special features, not only of novelty, but of great utility and interest.

Touching on this point a compound direct-acting engine was put down at Hebden Colliery by Messrs. Joicey, of Newcastle, in 1886, which was constructed to work without a flywheel, although provided with a crank shaft having two

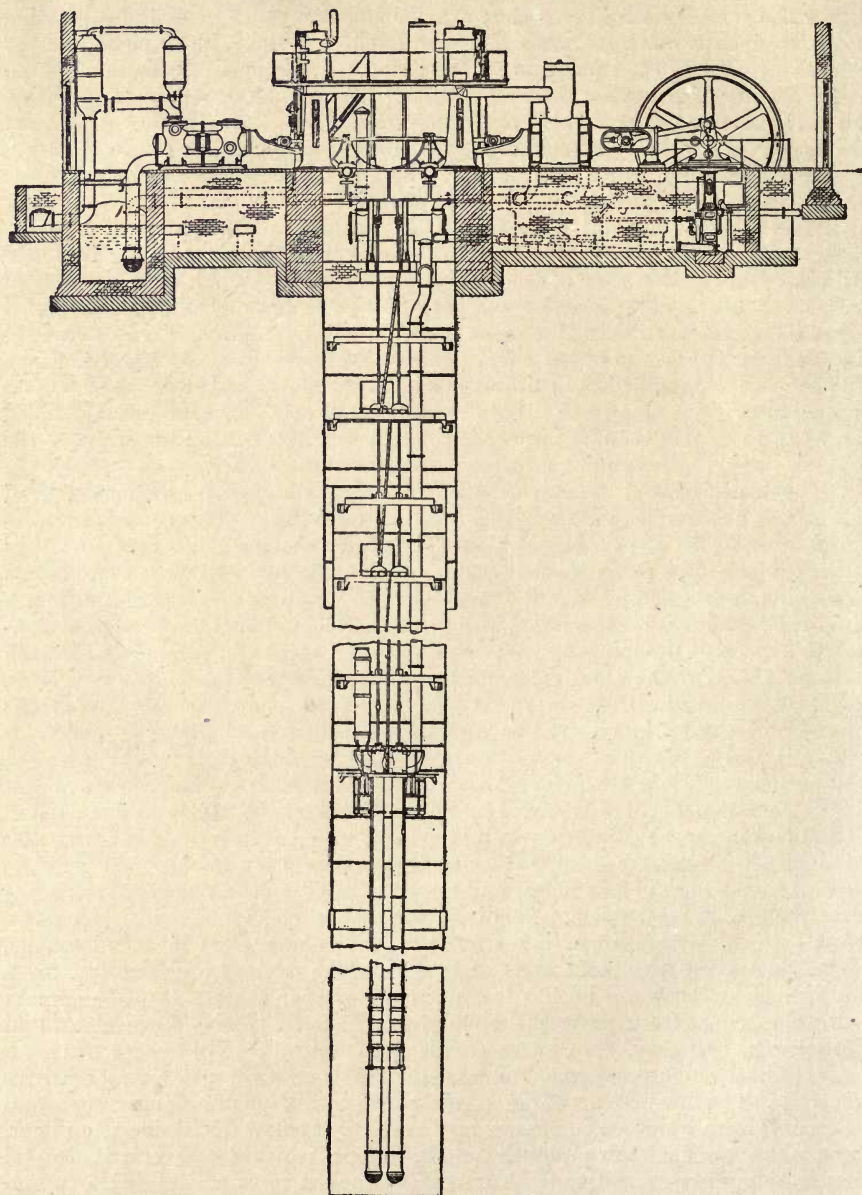

Fig. 9.—Sectional Elevation of Simpson Triple-Expansion Rotatory Deep-level Balanced Action Pumping Engine for the Barnet Gas and Water Company.

cranks at 90° , one of which was connected up to the piston of a small secondary engine, which was used solely for the purpose of turning the crank of the main engine over the centres, the crank shaft being utilised for actuating the distributing valves of both engines, and as no flywheel was used, the time taken in getting over the centres could be entirely regulated by the supply valve of the auxiliary engine. In this rather remarkable pumping engine the high-pressure cylinder was 20 inches diameter, and the low-pressure 48 inches by 5 feet stroke, which, of course, was never less than this; the pumps were of the directly connected double-acting outside packed ram plunger type of 10 inches diameter, and worked against a 1,100-foot water head. The engine, which is horizontal, was placed down in the mine at the 1,100-foot level, and worked well without compensators, as used in the high-duty duplex Worthingtons; without differential action, as employed in the direct-acting Davey simplex, and without flywheel, as used in the various types of rotatory pumping engines; consequently the crank shaft, which is comparatively small, is only used to control the working of the engine without regard to a high degree of expansion, and the principal advantage of a rotative engine, which is, of course, due to the steadying action of the flywheel, is therefore entirely lost in this case.

The compound rotative beam pumping engine (illustrated by Fig. 10) put down at the Chatham Waterworks by Messrs. Simpson & Co. in 1901, is designed to raise $3\frac{1}{3}$ millions of gallons per 24 hours from a well into reservoirs which give a total combined lift of 380 feet. In this case both the high-lift and low-lift pumps are of the bucket and plunger type with double-seated valves, the low-lift pump delivers into a tank placed outside the engine room, and on its way forcing the water through a surface condenser shown underneath the steam cylinders, the exhaust before entering the condensers passing through a tubular feed-water heater. The steam distribution is by Corliss trip gear, both steam cylinders being jacketed throughout, and the engine placed under the control of a sensitive governor situated alongside the high-pressure cylinder and immediately over the gear shaft used to actuate the distributing valves, and the plungers of both pumps are driven from points immediately adjacent to the crank connecting-rod, and thus relieves the beam of considerable vibration and strain. The illustration gives a capital idea, not only of the general design of this engine, but shows in a comprehensive manner the well-considered arrangement and fixing of both pumps as well as the construction of the foundation and building of this splendid example of rotative beam pumping engine with its 26-foot diameter flywheel.

The rotative beam compound pumping engine, illustrated by Fig. 11, represents a design of pump disposition for this type of engine of modern construction, this particular engine having cylinders $24\frac{1}{2}$ and 32 inches diameter by 2 feet $8\frac{1}{4}$ inches and 4 feet 6 inches stroke respectively. Of the two plunger pumps, the one located under the high-pressure cylinder is worked by a prolongation of the piston-rod, and the other direct from the beam by a connecting-rod, which is pivoted within the hollow plunger ram trunk fashion. Both of these single-acting ram plungers have a diameter of $16\frac{1}{2}$ inches and a stroke of 2 feet $8\frac{1}{4}$ inches, and pump against a water head (including friction of water in the pipes) of 300 feet, the engine running at the moderate speed of 15 revolutions per minute. Under these conditions the mechanical efficiency of these engines is 86 per cent., and the duty $98\frac{1}{2}$ millions per cwt. of Welsh coal. All the water from the pumps is circulated on its way to the delivery mains through the surface condenser (shown in the sectional cut) as in Fig. 10; also, in regard to the general construction of this engine it may be mentioned that the cylinders, entablature, columns, and

crank-shaft pillow blocks are bolted down to massive girders with broad bearing on the masonry; the entablature rests on and is bolted to piers built in the side wall, the spring beams extending into the end walls of the house. The engine

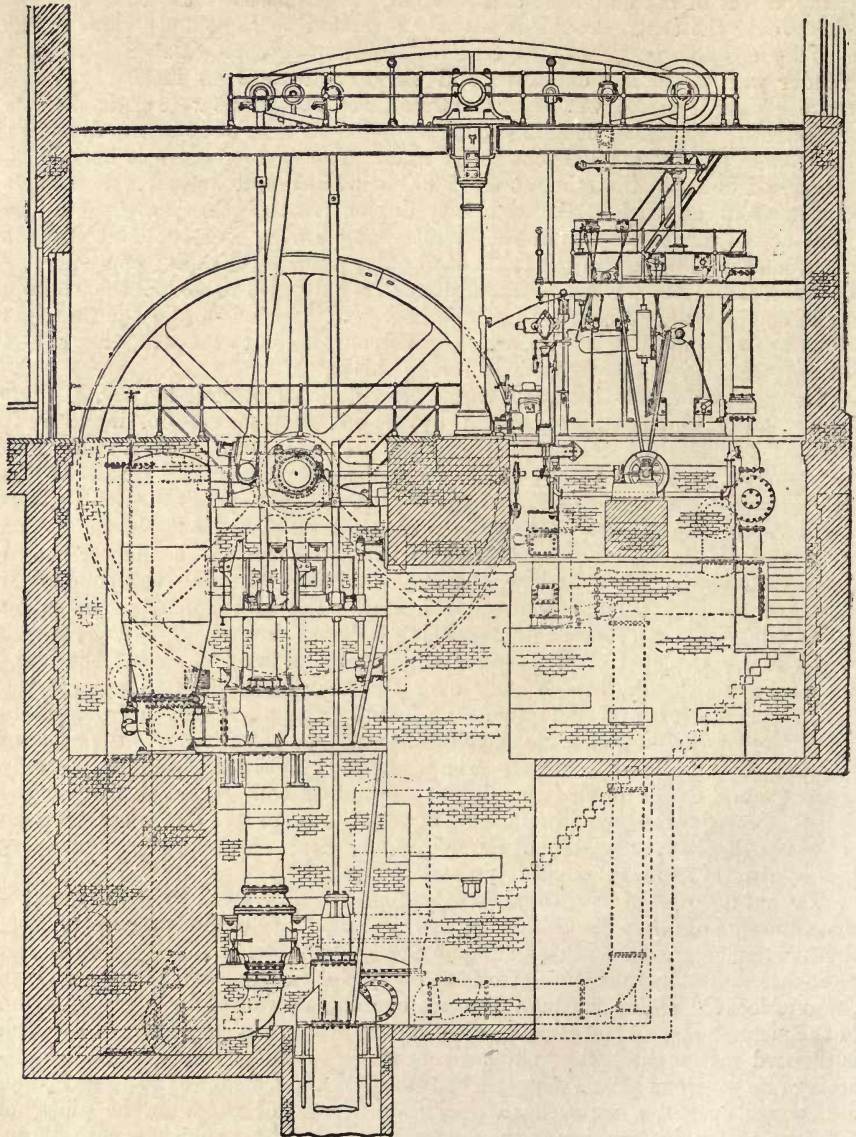

Fig. 10.—Compound Rotative Beam Pumping Engine, with Bucket and Plunger, High and Low-lift Pumps, for Chatham Waterworks.

beam is formed of two elliptical-shaped steel plates, each $2\frac{1}{4}$ inches thick, and held together by cast-iron distance pieces riveted through. Mild steel gudgeons

are fitted for the various centres, and securely keyed to their respective bosses, the crossheads of both cylinders being guided vertically by an improved design of Watt parallel motion, having close-ended links with adjustable cottered

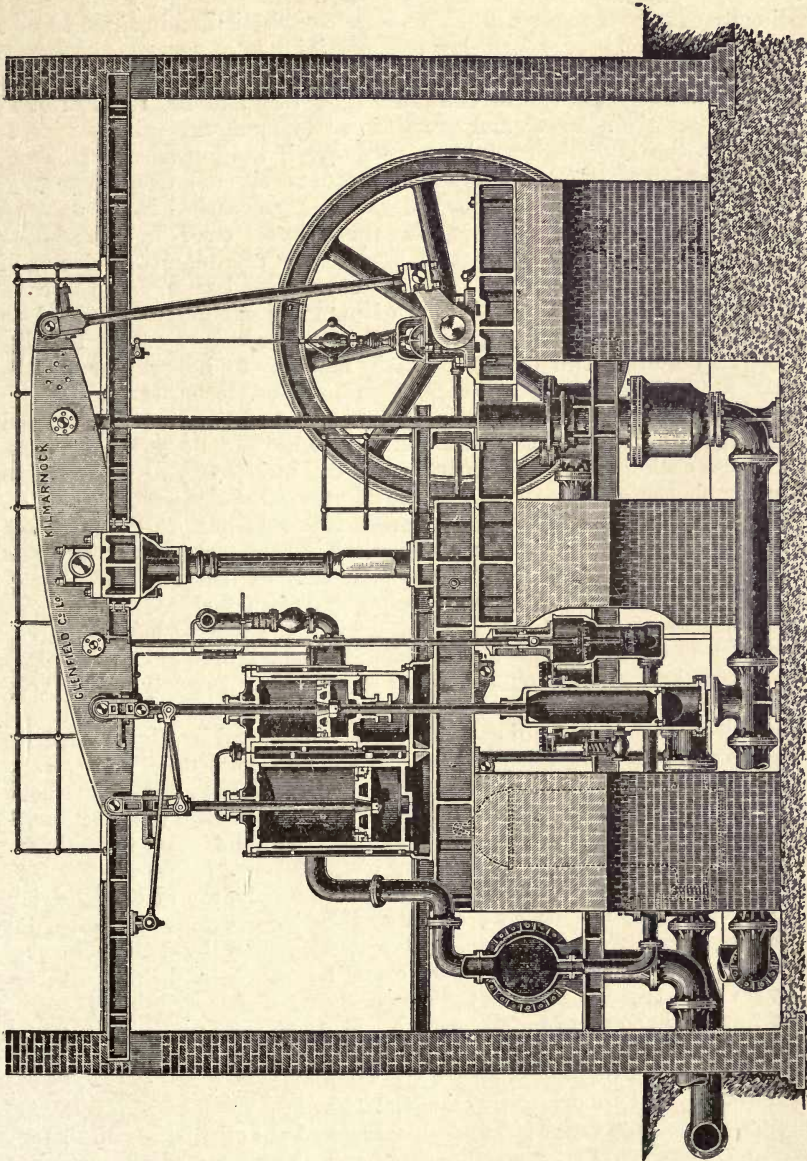

Fig. 11.—Compound Rotative Beam Pumping Engine, with Two Single-acting Ram-plunger High-lift Pumps.

filling blocks. A "Porter" governor, driven by spur and bevel gearing, is located immediately over the crank shaft, and controls a throttle valve on the high-pressure cylinder, the flywheel of 14 tons weight and 16 feet diameter

enabling the engine to turn the centres easily when running at a much slower speed than the normal and against the full water resistance.

Geared pumping engines have one great advantage—viz., in making it possible to speed up the engine—and by this means reduce its cost, for an engine when directly connected to a set of pumps is necessarily limited in speed to that of the plungers, which is very far below that obtaining in ordinary steam engine practice, the piston or plunger speed of the pump rarely exceeding 250 feet per minute in either American or Continental practice, and 100 to 220 feet in British, consequently a larger and proportionately more expensive engine is required to do the work than would be necessary if the pumps could be run faster. Nothing impresses one more than the immense size of a direct-connected rotary pumping engine for the power developed; so marked is this that an engine, for instance, of the marine type only indicates one-fourth the power when working a set of pumps direct as it would be capable of developing if speeded up to normal. However, there are other considerations in the case, and in general practice the geared type of pumping engine is not found so extensively used as one might expect, for the smaller engine entails the disadvantage of requiring two crank shafts, in addition to heavy gear wheels, and occupies a greater area of floor space than direct-connected types.

There is, notwithstanding, a possible advantage to be gained from geared plant, when, for instance, the engines and pumps are put down in duplicate, as in this case each engine can be arranged to drive either set of pumps, thus reducing the chance of a complete breakdown very considerably. A plant on these lines has just been installed at Portsmouth Harbour for pumping sea water in case of fire, and for other purposes. This plant consists of two sets of three-crank triple-expansion vertical steam engines and two three-throw geared pumping sets having plungers 16 inches by 3 feet 6 inches, and is capable of lifting 100 tons of water per hour 110 feet high, the gearing being arranged with two pinions on each engine shaft, which can be slid into gear with either or both pump-shaft wheels, an arrangement that may possibly prove very useful in an emergency.

A very interesting example of geared pumps is illustrated by Figs. 12 and 13, both engines and pumps in this case being of the horizontal type, and capable of raising $1\frac{1}{2}$ millions of gallons per 24 hours. These pumping sets, which have been supplied in duplicate by Messrs. Brazil, Holborows & Straker for the Shoreham Waterworks—the pumping station being situated at the foot of the hill near Old Shoreham and the reservoir on the brow of the hill, at a height of about 200 feet above the water level in the well or source of supply, are of the following description:—The engines, which are of double-cylinder compound horizontal type, with disc cranks and cylinders 13 and 22 inches by 24-inch stroke, run at 72 revolutions per minute under normal conditions, and drive a three-throw pump shaft through two pairs of cast-iron gear wheels with helical teeth, having a fine pitch, so as to obtain smooth and silent working, any clang and vibration being so reduced as to be barely perceptible. The pump barrels are $14\frac{3}{4}$ inches in diameter by 24-inch stroke, the three plungers being of the outside packed ram type, and are driven by cranks at 120° , at a speed of 24 revolutions per minute—i.e., at just under 100 feet plunger speed per minute. Both suction and delivery pipes are 12 inches diameter, and the valves of the multiple type, a separate set being used for each pump with a waterway capacity equal to the area of each plunger; both the suction and delivery sets of valves, which are gun-metal with mitre seats, are held down to seatings screwed into the casing floor by springs arranged under the seatings, the valves being guided by

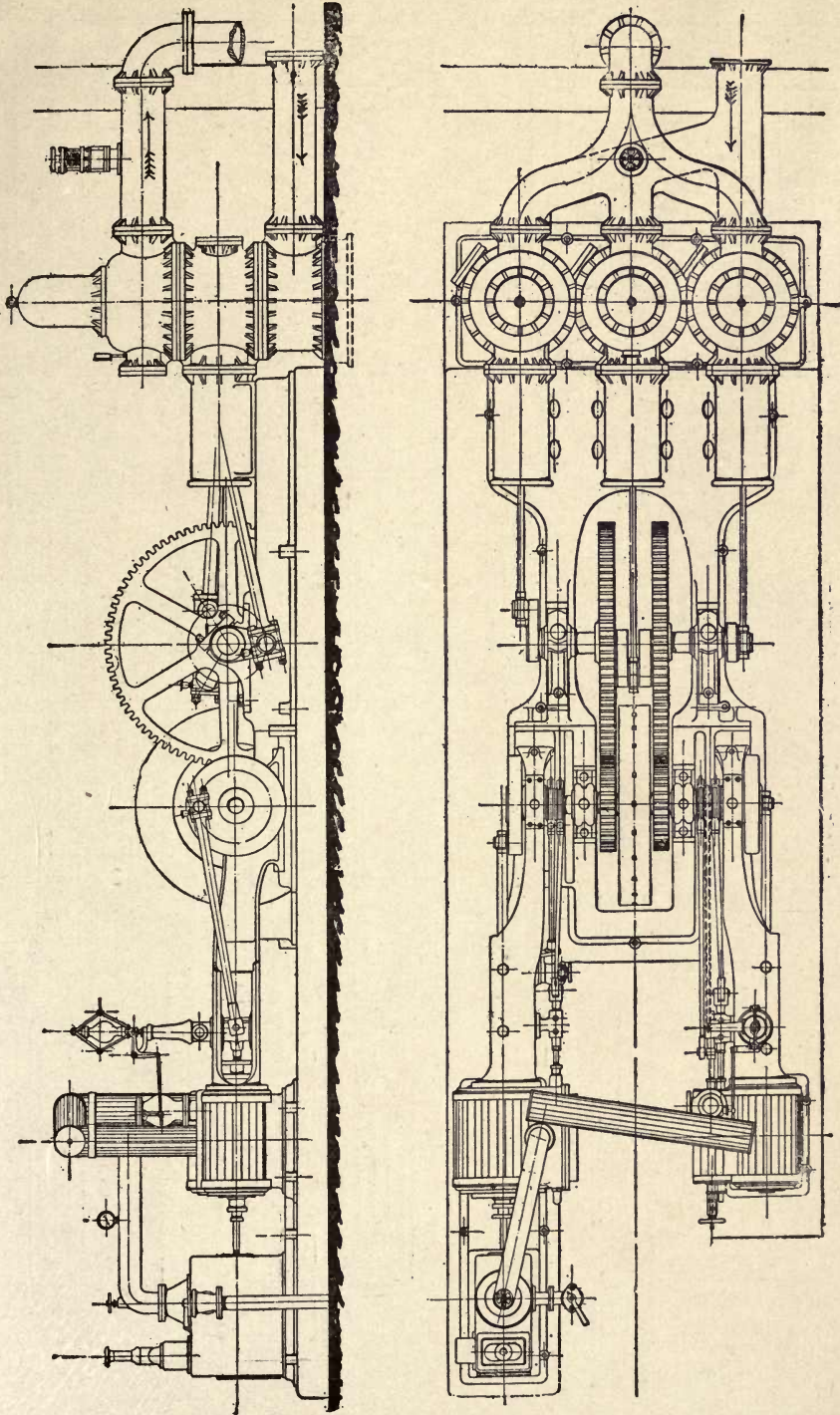

Fig. 12.—Three-throw Force Pumps for Shoreham.

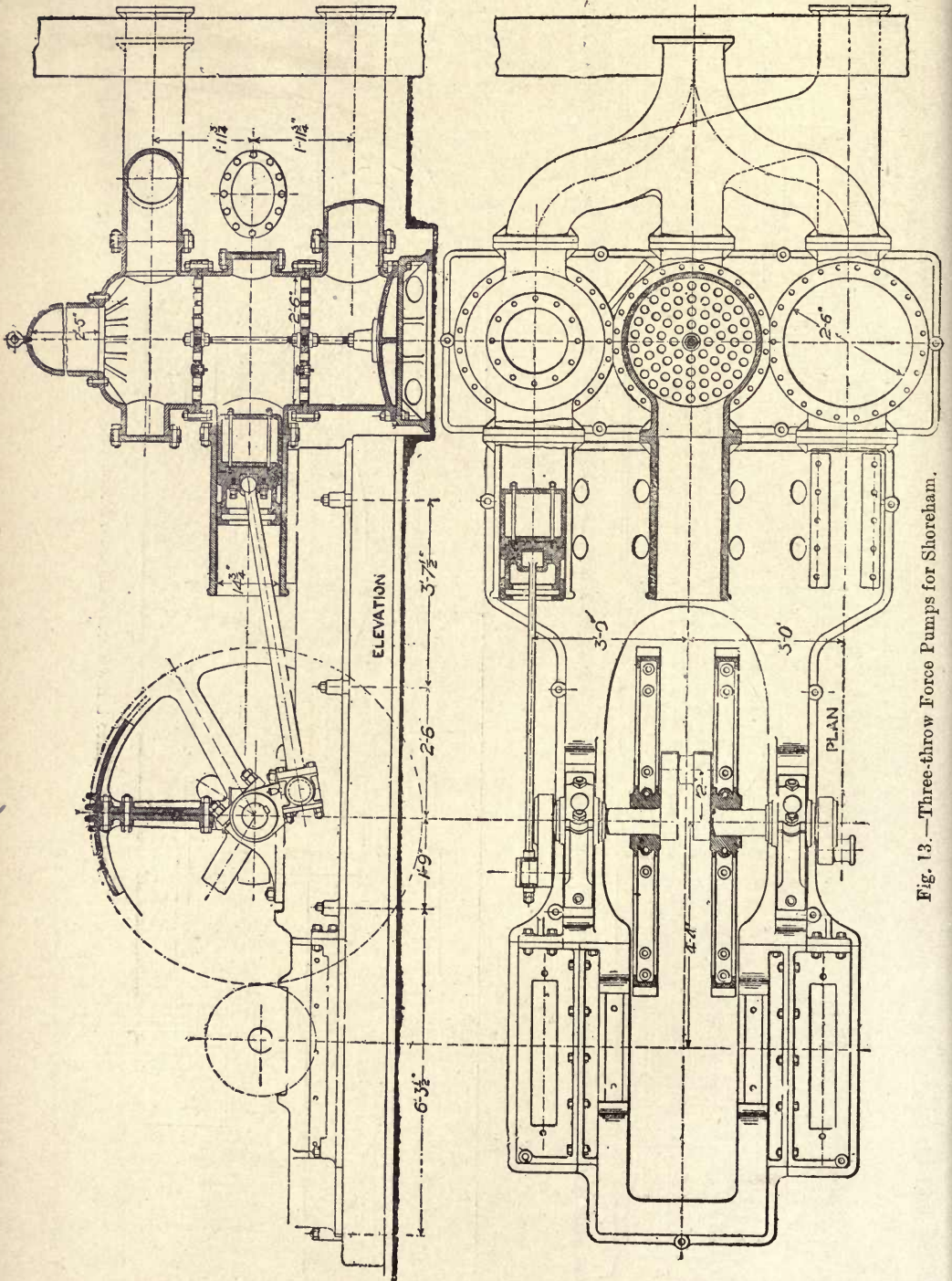

Fig. 13.—Three-throw Force Pumps for Shoreham.

vanes set at a slight angle. The engines exhaust into jet condensers, the air pumps being arranged tandem to the low-pressure cylinder, the whole thus forming a complete and very get-at-able set of pumps, the flywheel being located between the two pinions, and quite out of the way of the cylinder frames. It will be noted from this description, together with the assistance of the illustrations of these very simple and efficient force pumps, that the drive from the engines is centralised at two points between each pump crank, and that the design shows in several other ways evidence of very careful consideration.

What may be characterised as being the standard design for a direct-connected rotatory pumping engine is the vertical three-crank type with flywheels arranged between the bearings, as shown by Figs. 14 and 15, in which the two outer cranks are generally overhung, except in very large engines when the crank

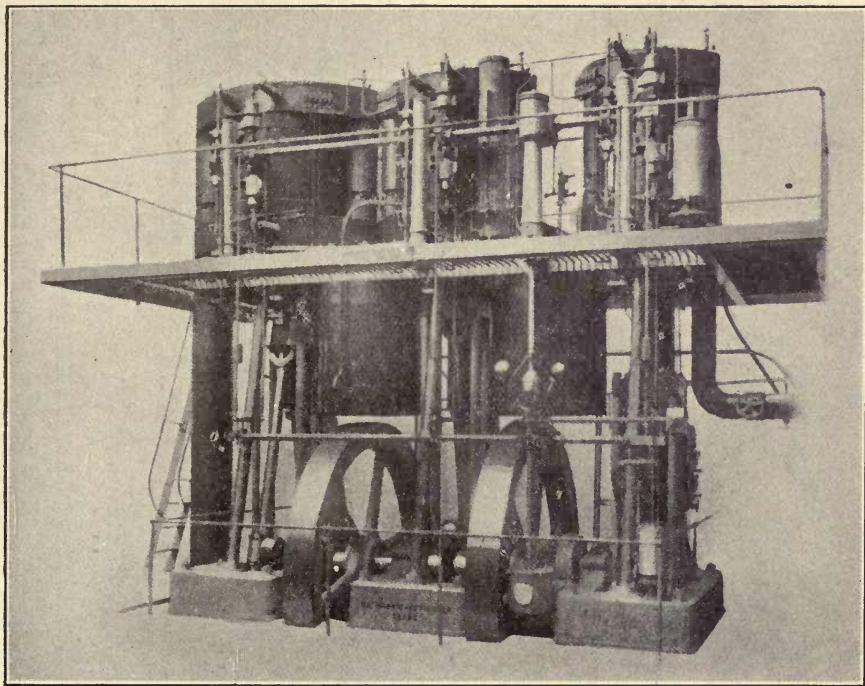

Fig. 14.—Three crank Triple-expansion Pumping Engine for Argentina.

shaft is built up in two separate parts, the pin of the centre crank of one part engaging with a bearing block fitted in the web of the other part; and accordingly, the shaft being divided in the middle, any difference in the adjustment, wear, or level in the two sets of bearings can be accommodated, there being four or six bearings for the complete shaft. In this design, as in all vertical engines directly connected to the pumps, two rods are used which connect on to cross-heads above and below the crank shaft, the rods being situated between the crank webs and bearings, and at opposite sides of the shaft in the usual way. The pumps, save in some exceptional cases, are of the single-acting ram plunger type, and may be used in two sets arranged one below the other to serve in the capacity of high- and low-lift pumps, when the depth does not

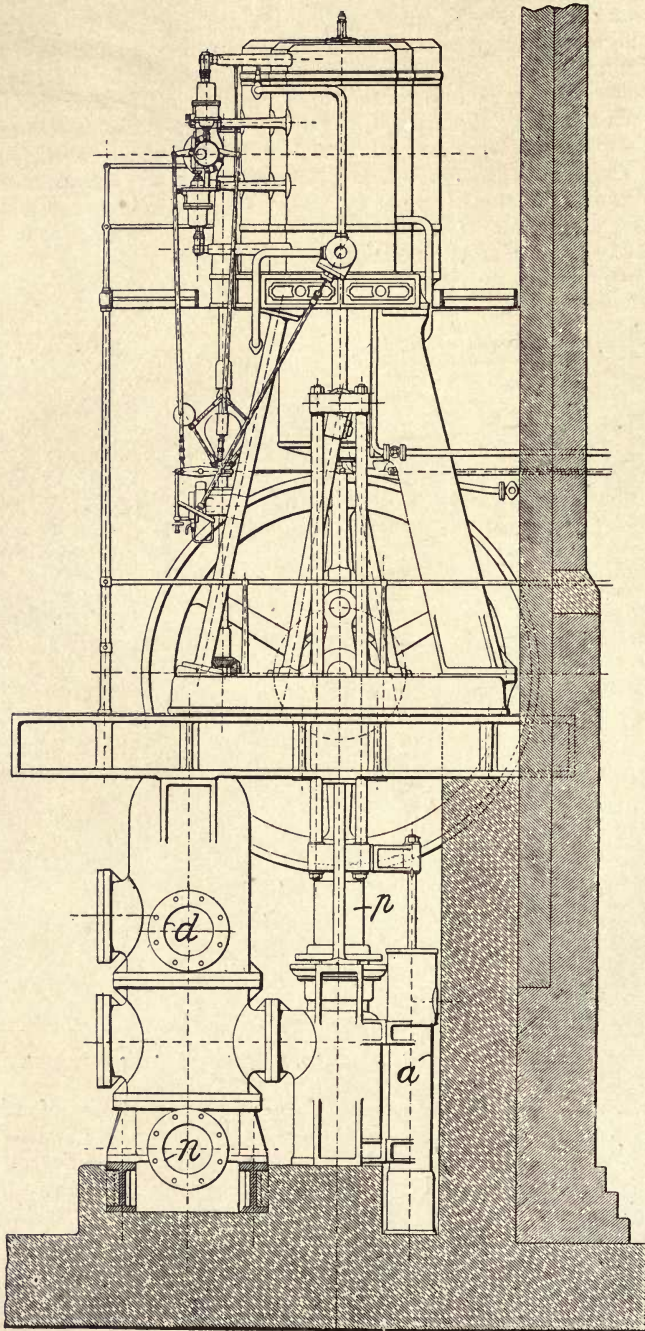

Fig. 15.—Cross Sectional Elevation of Three-crank Pumping Engine for Leeds Waterworks.

exceed 50 or 60 feet or so. An engine of this type has recently been supplied to the Consolidated Waterworks Company of Rosario de Santa Fe in Argentina, where it supplies this town with water from the river Panama at the rate of 4,000,000 gallons per 24 hours against a head on the high-lift pumps of 170 feet, including friction, and a head of 55 feet with the low-lift set of pumps.

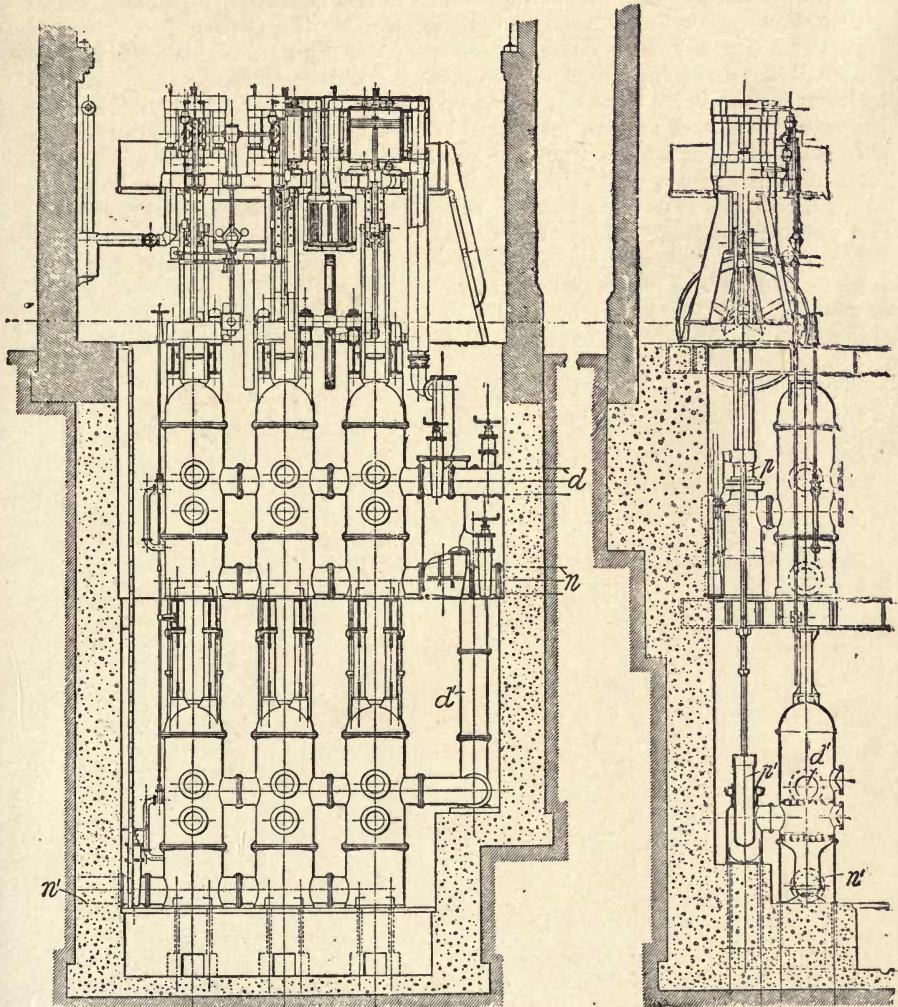

Fig. 15a.—Sectional Elevations of Three-crank Pumping Engines fitted with separate Sets of High- and Low-service Ram Plungers, for Rosario Waterworks, Argentina.

This engine is of the triple-expansion inverted vertical surface condensing type, as illustrated by Figs. 14 and 1b, with the exception of the low-lift pumps. The cylinders are respectively 15, 25, and 40 inches diameter, and drive three single-acting ram plungers 16 inches diameter for the high-lift and $16\frac{1}{2}$ inches in diameter for the low-lift (all having a stroke of 3 feet) at a speed.

of 36 revolutions per minute, which corresponds to a plunger speed of 216 feet per minute. The valves are gun-metal, faced with rubber, and are of the multiple type for both sets of pumps, and of a waterway capacity exceeding the area of the plungers. The three cranks are set at 120° , the two outer cranks being overhung as shown; and on the shaft are keyed two built-up flywheels, one situated between each pair of bearings and on each side of the middle crank. The distributing valves in each steam cylinder are of the Corliss type, operated by a Craig trip motion, and are opened positively by hardened steel dies fixed on small eccentric clips that engage with other corresponding dies attached to levers on the valve spindles; which eccentric clips receive their motion from the valve shaft, and, as seen, are placed in front of the cylinders, where they are driven by cut gear wheels from the crank shaft. By means of this improved form of a trip gear a very rapid steam opening is obtained, and the dies keep in good condition for years without renewing, owing to the sliding motion of one die upon another tending to keep the cut-off edges sharp. The exhaust valves are all operated by cams, and each steam valve is separately adjustable for lap, lead, cut-off, cushion, and release while running. An automatic safety controlling device operated by an hydraulic governor is fitted to cut off the steam supply, and destroy the vacuum in case of loss of load, resulting for instance from a fractured pipe.

The following particulars have been abstracted from a report on the working of this engine by Mr. Thos. Thomson, the company's resident engineer:—

Ratio of cylinders	1 : 2.86 : 7.35.
„ receiver capacity to I.P. cylinder,	2.27.
„ „ „ L.P. „	1.1.

All cylinders and receivers are steam-jacketed, the steam pressure at engine being 177 lbs. per square inch, and the superheat 53° F.

The pressure in H.P. receiver,	39.7 lbs.
„ „ I.P. „	3.7 „
Vacuum in surface condenser,	27.9 inches.
Indicated power of H.P. cylinder,	77.69 I.H.P.
„ „ I.P. „	66.33 „
„ „ L.P. „	85.98 „
Total for engine,	230 „
„ pumps,	212.5 „
Steam per pump H.P.,	12.28 lbs.
„ I.H.P.,	11.1 „
Mechanical efficiency,	91 per cent.
Thermo efficiency of indicated work,	20.8 „
„ „ actual work,	18.9 „
Actual duty per cwt. coal,	158 millions.

This is a remarkable and very creditable result for an engine of this size, and is usually only equalled by much larger engines.

The following particulars are also adduced from a report by Prof. Unwin on the running of a pair of similar engines supplied to the Leeds Corporation's Headingley Pumping Station in 1899, from the designs of Mr. A. Fowler, and will be interesting, as they indorse the very high economy obtained in other engines of this class:—Diameter—Cylinders, 15, 25, and 40 inches; pump rams, 13.48 inches; stroke, 3 feet. There are no low-lift pumps on these engines, and the

effective head of the high-lift pumps by the gauge measured 287 feet. The cut-off in high-pressure cylinder was $\cdot 28$; intermediate-pressure cylinder, $\cdot 28$; and low-pressure cylinder $\cdot 26$.

The indicated horse-power of H.P. cylinder,	. 52.4
" I.P. "	. 52.7
" L.P. "	. 78.5
Total indicated horse-power of engine,	. 183.7
" pumps,	. 166.7
Revolutions per minute,	. 34.6
Steam per I.H.P.,	. 11.9 lbs.
" P.H.P.,	. 13 "
Duty per cwt. coal,	. 125.35 millions.

The duty of the engine tested, if corrected to the equivalent of 9.5 lbs. evaporation per pound of coal, works out at 154,000,000, and is just under the result obtained in the Rosario engine, and approaches very nearly to the highest results obtained in American engines of this type, which are made in sizes up to 1,000 indicated horse-power, with in-between column flywheels, triple-expansion, and divided three-throw crank shafts. Several engines may be met with in the various water-supply stations of this and other countries of a similar build to this; but with only two cylinders working compound, these are carried by two columns, between which is located the flywheel, with the cranks both over-hung. In connection with this rather old type of pumping engine, double-acting pumps are usually fitted (the cranks being at 90°), and often the heavy single flywheel is not machined as in the case of many old beam engines with a rotation rarely exceeding 10 revolutions per minute in either case.

A modified form of pumping engine belonging to the vertical rotatory class, but with outside flywheels and known as the British or marine type, is widely adopted in modern pumping stations of large capacity. A splendid example of this class of engine is illustrated by the sectional cut (Fig. 16), which represents an elevation of one of three triple-expansion three-crank inverted vertical engines with direct-connected double-acting piston plunger pumps, supplied by the North-Eastern Marine Engine Co. to the Riverdale Pumping Station at Hampton-on-Thames. These engines, which are each capable of delivering 9,000,000 gallons per 24 hours against a water head of 280 feet, will work smoothly up to 25 revolutions per minute, and the largest of their class in this country, were built from the designs of Mr. James Restler, the engineer to the Vauxhall and Southwark district of the Metropolitan Water Board, another pair of engines of somewhat similar construction, but smaller and having two cranks, being installed at the Wandsworth relay station.

The cut illustrating the Riverdale engines has been reproduced from an engraving appearing in *The Engineer*, issued on August 2nd. 1901, from which the following particulars are taken:—The cylinders are respectively 20, 29, and 54 inches diameter, and the double-acting pumps $16\frac{1}{2}$ inches diameter, all having a stroke of 5 feet, and normally work at about 200 piston speed per minute. The crank shafts of these engines are 13 inches diameter at the bearings, which are 18 inches long; the crank pins, 12 inches diameter by 14 inches long; the crank webs, 22 inches wide by 8 inches thick; the flywheel at each end of the crank frame, which is 26 feet long, is 15 feet diameter by 12 inches wide, the rims being 15 inches deep, and is supported by an outside bearing. The steam distribution is by piston valves for the high-pressure and intermediate-pressure cylinders, and double-slide expansion valves for the

low-pressure cylinder. Each cylinder and valve chest is steam-jacketed, the cylinders also having jacketed covers. The ratio of expansion can be controlled from the floor level for all three cylinders, the attendant having within his reach at one point all the controlling levers and wheels necessary for stopping, starting, or for any steam adjustment. In addition to this a flyball governor prevents racing on a reduced load.

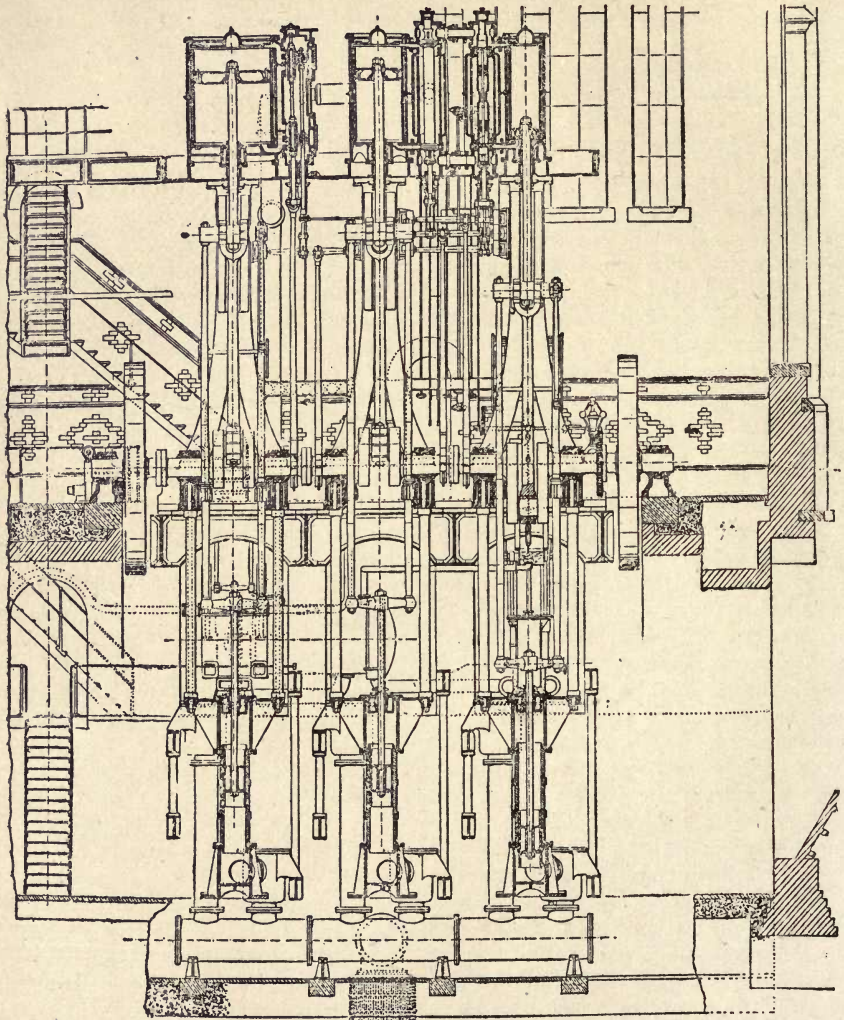

Fig. 16.—Sectional Elevation of Triple-expansion Three-crank Pumping Engine, with Double-acting High-lift Pumps, at the Riverdale Station, Hampton-on-Thames.

To give a better idea of the size of these engines, it may be stated that the engine-house is 125 feet long by 40 feet wide, and the length over the outside bearings of each engine is over 40 feet; the height from the engine floor to the cylinder covers is approximately 33 feet, and the depth to the pump floor 34 feet.

The pumps are each provided with two suction and two delivery valves of the multiple bee-hive pattern, similar in form to Fig. 44, but with only two tiers

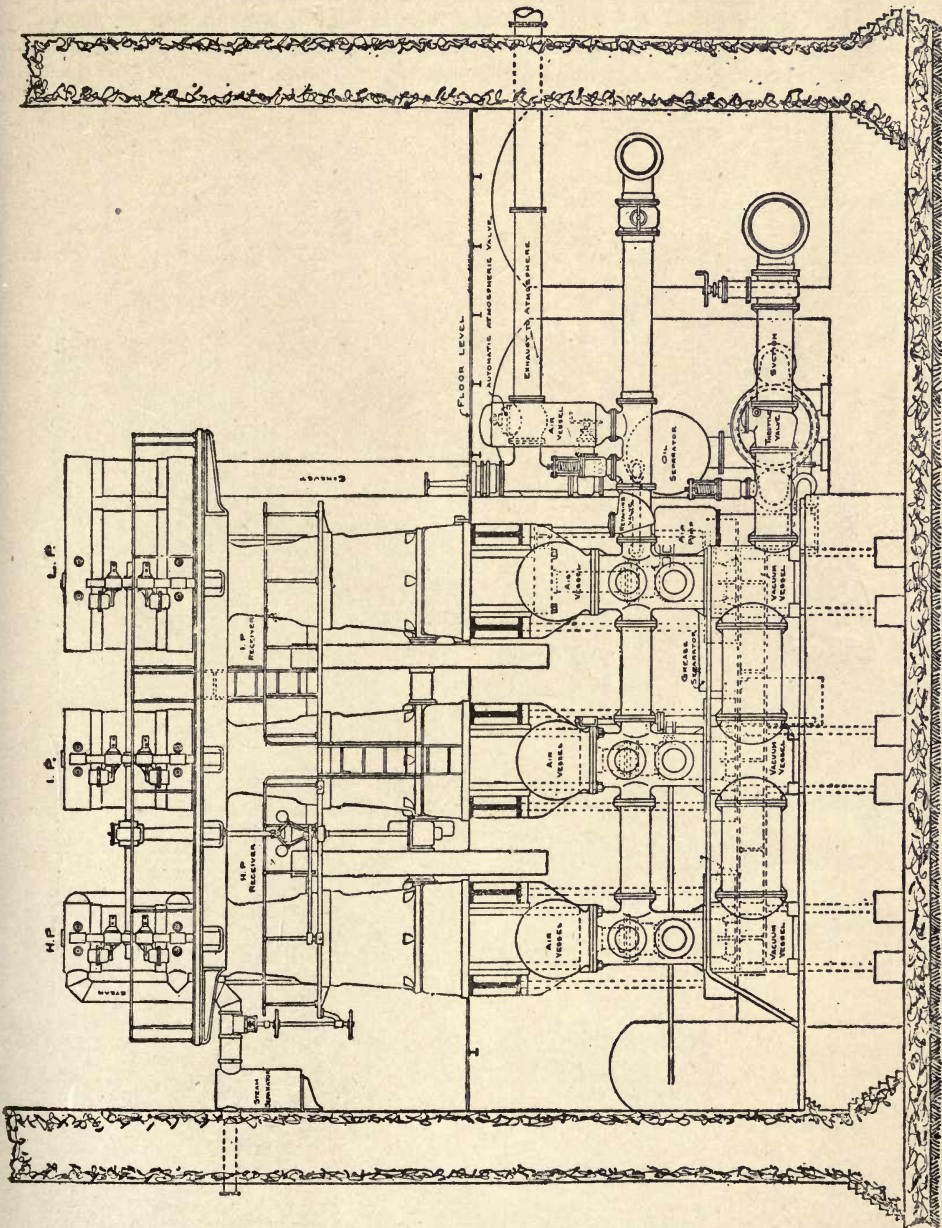

Fig. 17.—Elevation of One of Four Triple-expansion Pumping Engines for Johannesburg.

of valves, which are of the same pattern as shown by Fig. 56. There are ten valves in the bottom tier and six in the top tier of each valve box, each valve

being about 5 inches outside diameter, and are together capable of affording a waterway equal to about 60 per cent. of the area of the piston plungers, which are 18 inches long, and supplied with no other packing than water rings $\frac{3}{8}$ inch wide by $\frac{1}{8}$ inch deep, spaced $1\frac{1}{2}$ inches apart. The indicated horse-power of these engines when running at 20 revolutions per minute is approximately 500, which is equal to 450 effective or pump horse-power.

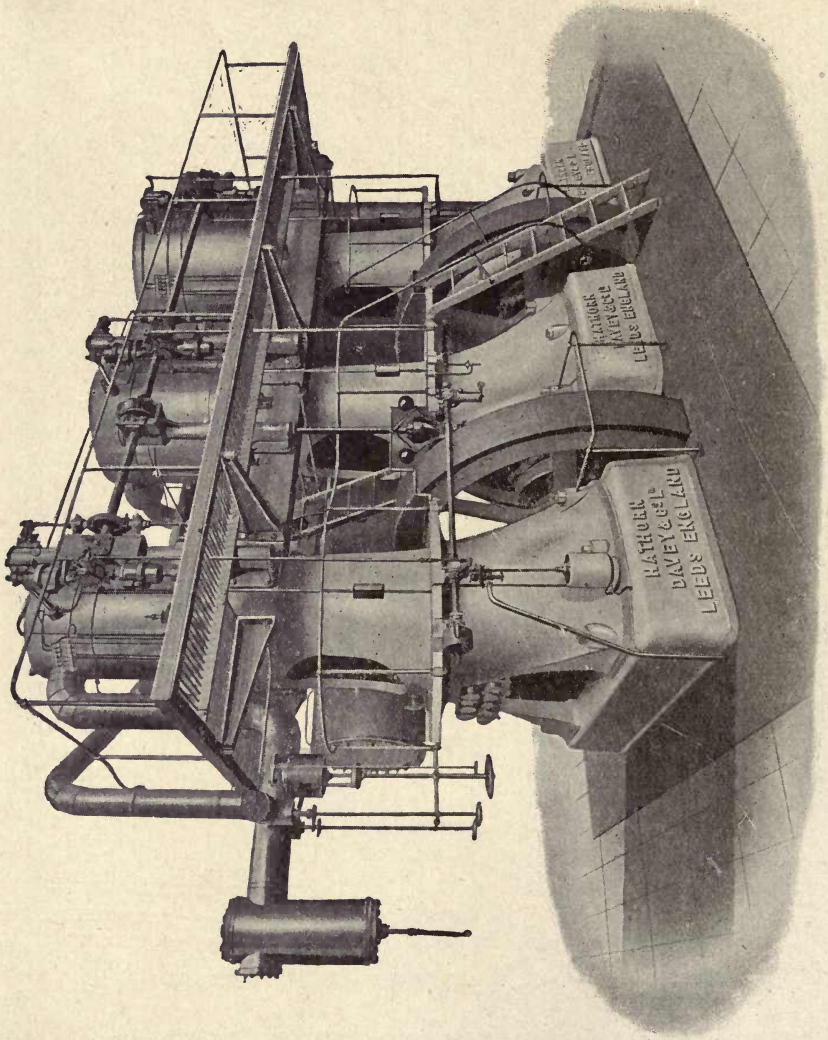

Fig. 17a.—General View of one of the "Rand" Pumping Engines.

Another pair of engines of this class—viz., with three cranks and outside flywheels, has recently been put down at the Patcham Waterworks, Brighton, from the designs of Mr. James Johnston. These engines differ in one respect from the foregoing in having low-lift or, rather, deep-level pumps as well as

high-lift pumps, the low-lift pumps, of which there are two, being worked by a fourth crank through a pair of balancing quadrants, after the fashion of the engine shown at Fig. 9 *ante*. The deep-level pumps are $22\frac{3}{4}$ inches diameter by 3 feet stroke, and are of the bucket type, with multiple valves 2 inches diameter by $\frac{3}{8}$ inch lift, arranged in a bee-hive box, and have a maximum lift of 175 feet; the high-lift pumps are of the single-acting ram plunger type, $15\frac{1}{4}$ inches diameter by 4 feet stroke, which are also supplied with small multiple valves of woodite and gun-metal seatings screwed into a bee-hive box, as shown by Fig. 44. The daily capacity of one of these engines is 3,000,000 gallons, against a total head of 500 feet, the three steam cylinders being respectively $21\frac{1}{2}$, $36\frac{1}{2}$, and 58 inches diameter by 4 feet stroke.

One of the most remarkable pumping engine installations has quite recently been put down by the Rand Water Board in Johannesburg, which, being situated at the top of a hill, necessitates an unparalleled height for the water to be pumped—viz., from 900 to 960 feet—and for this reason presents an excellent opportunity for demonstrating the superiority of the rotatory three-crank triple-expansion engine over other types when required to pump against a high-pressure head; in these four engines, however, the highest duty hitherto recorded has been exceeded, the guaranteed consumption of 11.5 lbs. of steam per pump or water horse-power having been improved upon in each engine under ordinary service conditions—a truly remarkable attainment, indeed, as will be realised by Prof. Orr's report below. In comparing the results obtained in these engines with the highest recorded with American pumping engines—viz., 181,000,000 foot-lbs. per 1,000 lbs. of steam—it must be borne in mind that that result was obtained in one of three sets at St. Louis, each capable of delivering 16.5 million gallons per 24 hours against a pressure head of 200 feet, whereas these engines of a much smaller size have only a daily output of 2.5 millions of gallons per 24 hours.

From the following Table it will be seen that the actual steam consumption per water-delivered horse-power is 10.904 lbs. at normal load, and 10.782 lbs. at overload, which amounts are respectively 5.18 and 6.24 per cent. below the guarantee given by the makers (Hathorn, Davey & Co.) of 11.5 lbs. of steam per P.H.P. per hour.

The consideration of rotatory pumping engines would be incomplete without some reference to a few of the many very large engines recently put down in the United States, where the prevailing practice is to favour the type shown by Figs. 14, 15, and 17, with in-between column flywheels and crank shaft carried by four or six bearings, the shaft being usually divided at the web of the centre crank where the join is by a bearing block with a slight movement. The steam distribution is by Corliss valves for high-pressure and intermediate-pressure cylinders and poppet valves for the low-pressure cylinder. The piston speed is usually 200 feet or higher per minute; the pumps of the single-acting plunger type and the valves of the multiple type as illustrated by Fig. 56.

At the Cincinnati Waterworks there are four triple-expansion pumping engines of this type, each of 1,000 I.H.P., 98 feet high, with a low-pressure cylinder 82 inches diameter by 8 feet stroke, and a speed of 256 feet per minute, the flywheels being 24 feet diameter, built up in eight segments. Corliss valves are placed in the covers of the high-pressure and intermediate-pressure cylinders, and multiple-seated poppets in the low-pressure cylinder, this being done to gain more steam way, and with less clearance than possible with other forms of valves.

At the Philadelphia Waterworks there are three sets of triples, same type

Report of Test of No. 2 Engine by Professor Orr.

Summary of Principal Results—Engine No. 2.

Steam cylinders: H.P. = 23 inches; I.P. = 43 inches; L.P. = 64 inches by 3 feet stroke.

	Normal Load. 1908.	Over-load. 1908.	Mean of Normal Load Tests on Four Engines.	Mean of Over-load Tests on Four Engines.
Date of test,	May 30th	May 31st
Test began,	10 a.m.	6.30 a.m.
Test ended,	8 p.m.	4.30 p.m.
Duration of test,	10 hours	10 hours
Barometer, inches of mercury,	25.3	25.3	25.24	25.25
Pressure of steam at engine stop valve— lbs. per square inch,	183.6	183.6	181.6	182.4
Vacuum (exhaust steam just entering con- denser), inches of mercury,	22.66	22.6	22.7	22.6
Temperature of steam at engine stop valve, degrees Fah.,	499.5	500	500	500
Revolutions per hour,	2028.6	2475.1	1925	2475
Revolutions per minute,	33.81	41.25	33.7	41.26
Piston speed, feet per minute,	202.9	247.5	202.3	247.5
Pump displacement per revolution—cubic feet,	7.0686	7.0686	7.068	7.068
Pump displacement per revolution (slip neglected), . . . lbs.	440.35	440.49	440.3	440.5
Water delivered per revolution, . . . lbs.	428.73	429.69	428.7	429.7
Water pumped per hour (slip neglected), lbs.	893,294	1,090,257	893,350	1,090,300
Water pumped per hour (actually delivered in Turffontein reservoir), . . . lbs.	869,722	1,063,526	869,700	1,063,500
Water pumped per hour (slip neglected), galls.	89,329	109,026	88,857	109,034
Water pumped per hour (actually delivered in Turffontein reservoir), . . . galls.	86,972	106,353	86,548	106,073
Slip of pump, per cent.	2.64	2.45	2.87	2.72
Effective head of water pumped, . . feet	929.7	975.5	914	975
Horse-power, water delivered (slip neglect- ed),	419.44	537.14	411.6	537
Horse-power, water delivered (actual), . .	408.37	523.97	400	522
Water collected from air pump discharge per hour, lbs.	3990.3	5080.8	4038	5246
Water collected from jacket and reheater drains per hour, lbs.	462.4	568.8	522	631
Steam consumption per hour, lbs.	4452.7	5649.6	10.47	10.35
Steam consumption per hour, per water delivered horse-power (slip neglected), lbs.	10.616	10.518	10.85	10.74
Steam consumption per water delivered horse-power (<i>i.e.</i> , for water actually de- livered to Turffontein reservoir), . . lbs.	10.904	10.782	11.08	10.94
Duty: Millions of foot-lbs. per 1,000 lbs. of steam, water delivered (slip ne- glected),	186.512	188.251	178.74	181.06
Duty: Millions of foot-lbs. per 1,000 lbs. of steam (water actually delivered in Turffontein reservoir),	181.591	183.634	173.6	176.1
Mechanical efficiency of steam engine, per cent.	97.9	97.49	96.6	96.4
Mechanical efficiency of pumps (slip neglected), per cent.	98.2	97.9	97.9	98.1
Mechanical efficiency of pumps (actual), per cent.	95.6	95.5	95	95.4

as foregoing, each to pump $16\frac{1}{2}$ millions of gallons, against a head of 160 feet. In these engines the low-pressure cylinders are 96 inches diameter by 5 feet 6 inches stroke; pump rams, 33 inches diameter, same stroke; valves as at Fig. 56, $4\frac{1}{2}$ inches diameter; steam pressure, 160 lbs., and duty 175 millions; weight of engine, just on 1,000 tons, *vide* Fig. 18.

At Chicago there are three sets of $13\frac{1}{2}$ million gallons daily capacity each; plungers, 42 inches diameter; stroke, 5 feet. At St. Louis there are three sets of the same type, each with a daily capacity of $16\frac{1}{2}$ million of gallons; 200 feet water head; pumps, 34 inches diameter by 6 feet stroke; piston speed, 198 feet per minute. In each of these sets—*i.e.*, complete engine and three pumps—there are nearly 1,200 valves, arranged in groups of 28 valves,

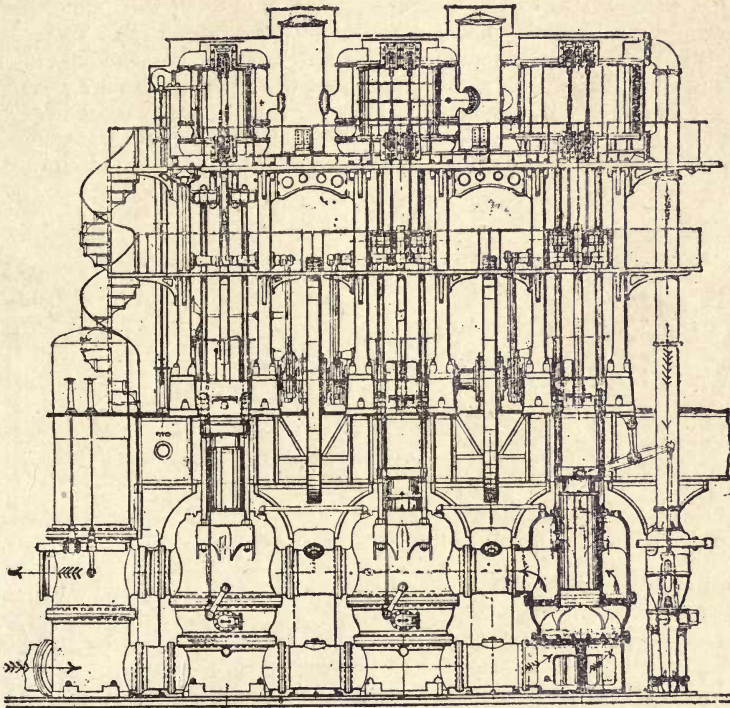

Fig. 18.—Triple-expansion High-duty Pumping Engine.

which are protected by a cage. The steam cylinders are 34, 62, and 94 inches diameter by 6 feet stroke; two flywheels, each 40 tons. And at Boston a pair of engines of 27 millions capacity each have cylinders 30, 56, and 87 inches diameter by 66 inches stroke; steam pressure, 185 lbs.; duty, 162 million gallons per cwt. Many other examples of smaller rotatory engines might be given.

In London it must be admitted there are some 20 pumping sets of the three-crank vertical type, ranging from 100 I.H.P. to 500 I.H.P., of which particulars of one at the New River Waterworks, Hornsey, may be useful as a comparison. This engine has cylinders 21, 34, and 52 inches diameter by 4 feet stroke, and three single-acting plunger pumps 27 inches diameter. On trial this engine developed a maximum of 326 I.H.P. at 25 revolutions per minute—*i.e.*, equal to 200 feet

per minute, and a maximum pump horse-power of 287. Duty per cwt. at an evaporation of 10 lbs., 170 millions, which is equal to the best results obtained with much larger engines above referred to, some particulars of which have been abstracted from the Proceedings Inst. M.E., 1905. Measurements of capacity and duty efficiency being stated in imperial gallons and per cwt. of coal on the basis of an evaporation of 10 lbs. of water per pound, which renders the comparison of results obtained from modern engines to those of the earlier pumping engines more simple. At the same time there can be no question that the unit adopted in the States of estimating the duty efficiency of a pumping set in terms of water raised per 1,000 lbs. of dry steam supplied to the engine gives a truer comparison, as it eliminates any uncertainty as to the efficiency of the generator.

A fairly representative illustration of American practice in the construction of water-supply engines is shown by Fig. 18, this representing one of four triple-expansion ram-plunger pumping engines supplied to the Queen Lane Pumping Station, Philadelphia, the dimensions of which engines are as follows:—Diameter high-pressure cylinder, 37 inches; diameter intermediate-pressure cylinder, 62 inches; diameter low-pressure, 96 inches; diameter water plungers, 34½ inches; stroke, 4.5 feet; revolutions per minute, 22.46; and corresponds

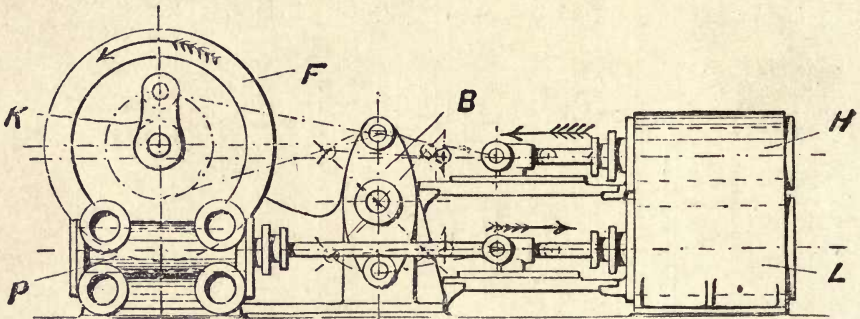
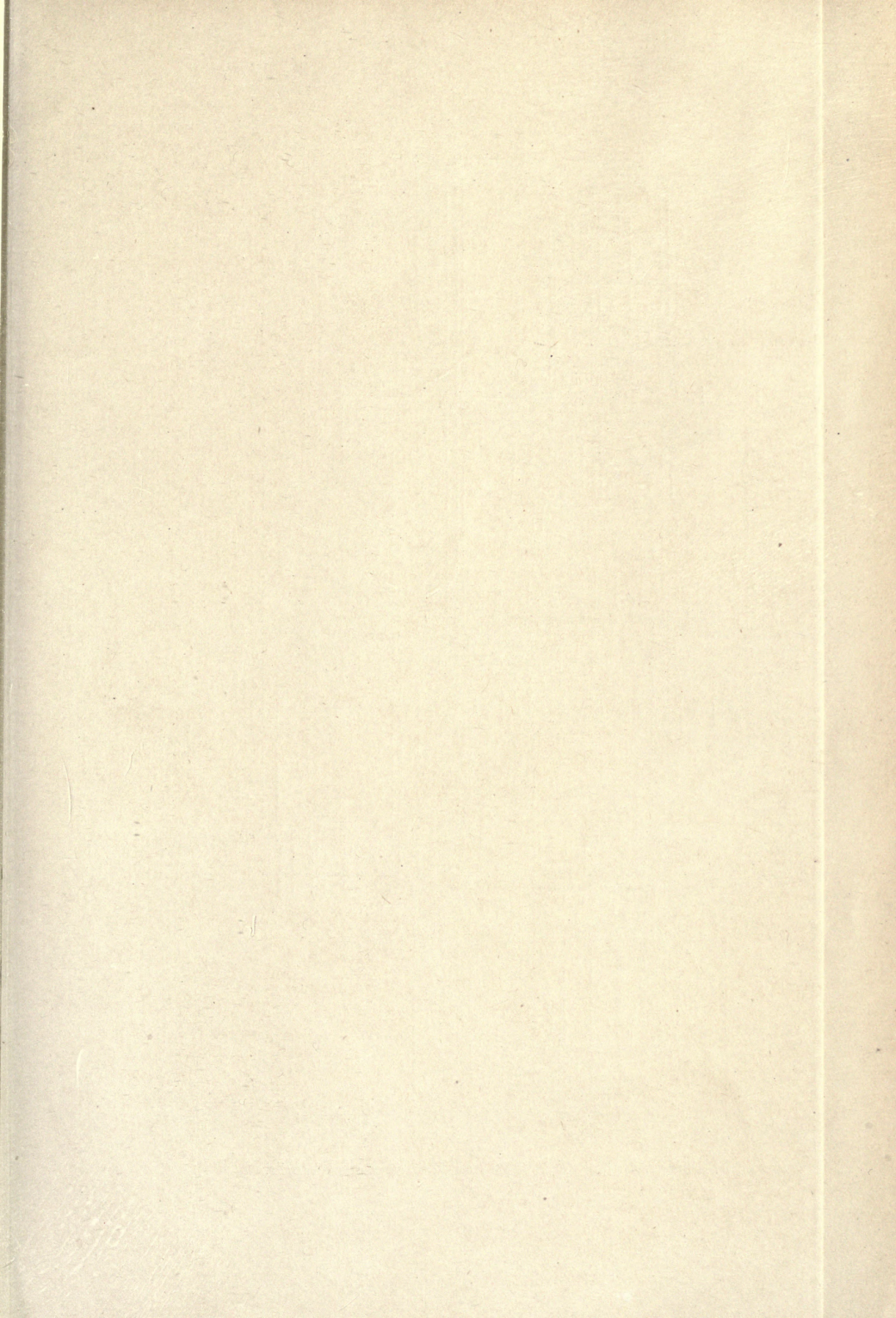

Fig. 19.—Rotative Duplex Pumping Engine.

to a speed of plunger travel of 202 feet per minute. In these engines there are 540 valves of the rubber-disc type, each 8 inches diameter, and giving a waterway area of 9 square inches, the total area of waterway both for the suction and discharge being 810 square inches, and is nearly equal to the area of the plunger—i.e., 936 square inches—the displacement of the three plungers for each engine being 63 gallons per revolution, and each engine is, therefore, equal to a capacity of 17.7 millions of gallons per diem. On a 24-hours' test of one of them this quantity was delivered against a pressure equal to a water head of 260 feet, this engine meanwhile indicating a little over 1,000 H.P. in the three steam cylinders and 933 H.P. in the pumps, thus showing a mechanical efficiency of 92 per cent.

In another engine a plunger speed equal to 273 feet per minute has been obtained, this high speed being made possible by fitting grid-iron suction and delivery valves, *vide* Chap. XV., Fig. 205, giving a waterway much exceeding the area of the plungers; these valves are actuated hydraulically—viz., each valve is provided with an actuating piston and cylinder using water from the force main. The water-motor cylinders used for this purpose are not capable of exerting enough power to traverse the valves until the pressure on them is



To face p. 37.]

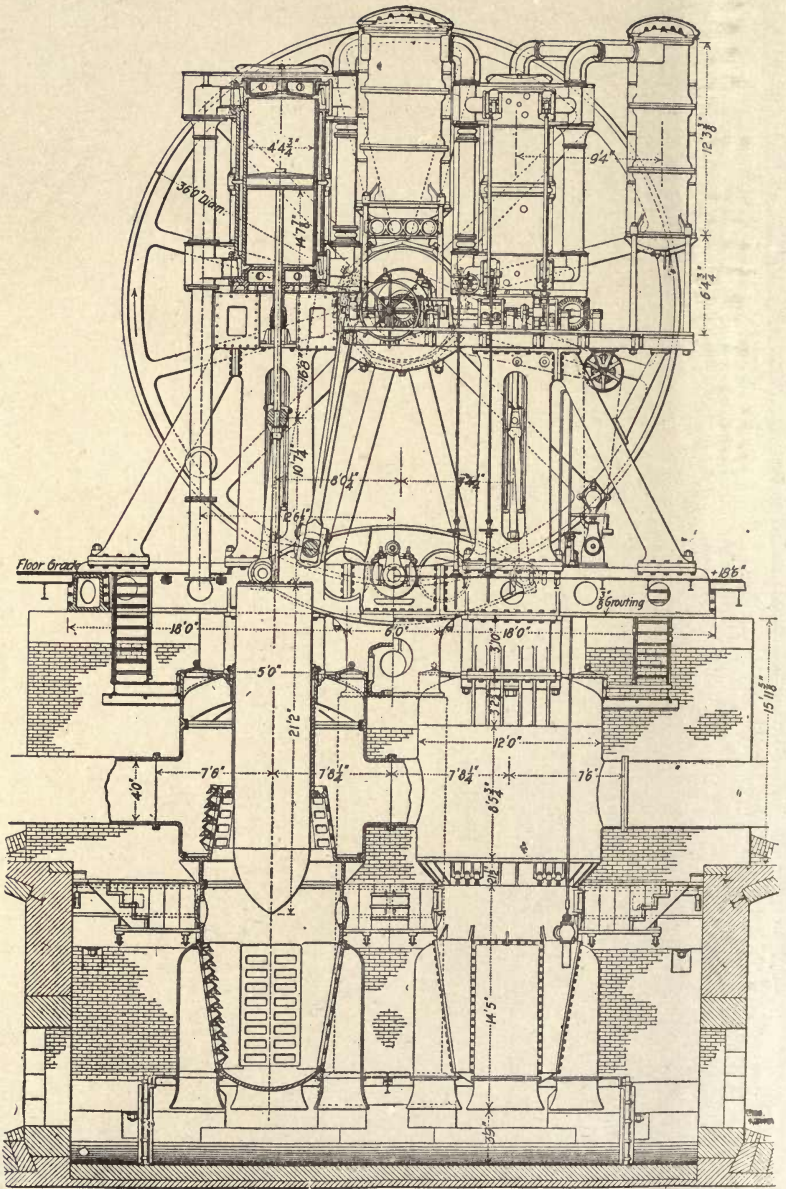
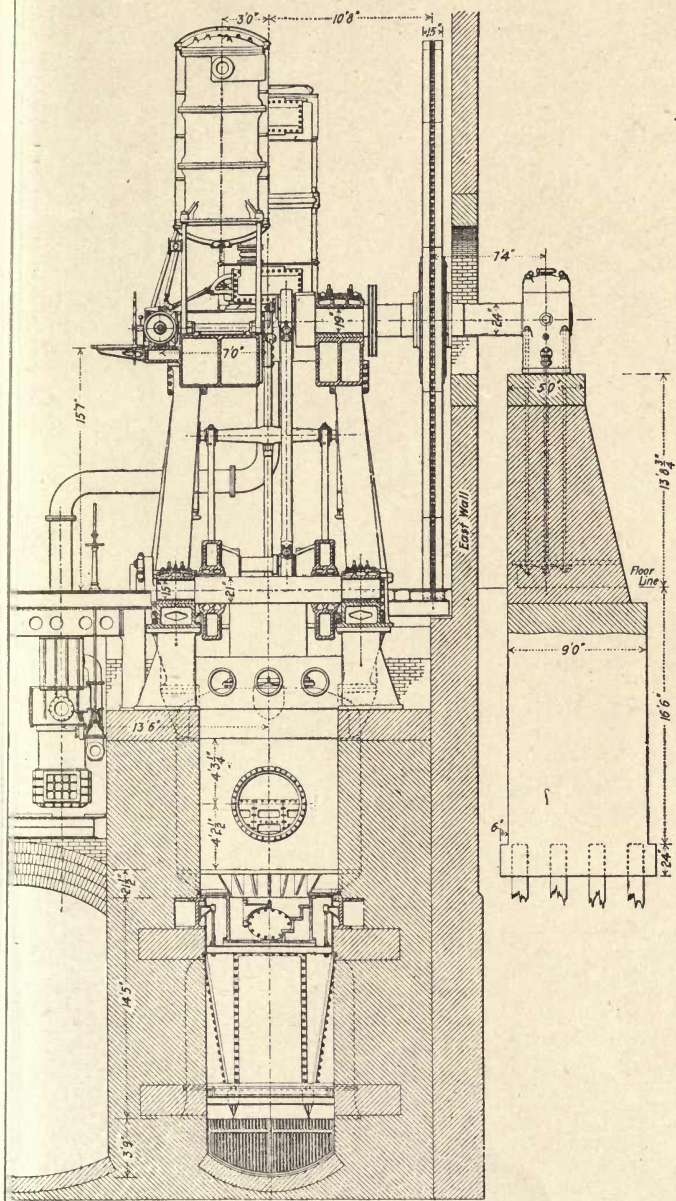

Fig. 20.—Sectional Elevations of Three-cylinder Rotative Beam Engine with T...



Single-acting Plunger Pumps for the Boston Main Drainage Works.

balanced ; at that instant—*i.e.*, when the ordinary rubber disc valves would commence to lift—these slide valves are raised slightly from their seats, and there being then no friction to prevent their movement, they are swiftly opened by the hydraulic plungers, these being controlled by cam-actuated lift valves to close at the correct moment ; the disadvantage sometimes experienced in pumping engines fitted with mechanically-actuated valves is practically removed in this engine, as the opening of the valves is automatically timed and works with entire smoothness and precision under the every-day conditions imposed on a water-supply engine.

There are some other rotatory pumping engines that may be described, such as the Holly type of horizontal beam engine, of which the latest design is to arrange two pairs of cross-compound cylinders H and L superposed to one another, as shown in Fig. 19, and to connect the crossheads of the four steam cylinders to a pair of walking beams B, the upper ends of which are connected to two overhung cranks K, a flywheel F being arranged centrally between the shaft bearings. The crank shaft is situated over the pair of double-acting piston-plunger pumps P, the plungers of which are directly connected to the high-pressure cylinder crossheads. This design is a little difficult to arrange suitably, and at its very best is complicated, although exceedingly compact for a flywheel engine. In action it resembles very closely two pairs of Blake Knowles duplex engines working together, the cranks being arranged at 90° , and the steam distribution by valves actuated from the crank shaft.

Yet another type of pumping engine is shown by the sectional cuts, Fig. 20, which example represents what is one of the largest reciprocating pumps in existence, and is used at the Boston Main Drainage Works, U.S.A. This engine, although having only two single-acting ram plungers, is capable of delivering 60 millions of imperial gallons per 24 hours against a head of from 40 to 50 feet, the two plungers being each 60 inches diameter by 10 feet stroke, and discharge into two 48-inch diameter delivery mains leading out in opposite directions. The valves for both suction and delivery are of the type shown by Fig. 45, there being 64 suction valves and 48 delivery valves, each 4 inches wide by about 17 to 20 inches long, and afford an aggregate waterway of 30 square feet for the suction area of each pump and 25 square feet for the delivery, this giving the exceptional proportions of 155 and 130 per cent. ratios of valve areas to plunger areas, and allows a plunger speed of nearly 300 feet per minute in an emergency such as caused by flooding. This engine is arranged with three steam cylinders, the high-pressure and intermediate-pressure cylinders of $18\frac{1}{2}$ and 33 inches diameter being directly over one plunger, and the low-pressure cylinder of $52\frac{3}{4}$ inches diameter over the other, the two sets being equalised by a beam, as shown in Fig. 19, connected to an overhung crank of 40-inch radius, for which the crank shaft measures 24 inches diameter between the 38-inch width bearings, and carries a 55-ton flywheel, 36 feet diameter by 15 inches wide. The engine is jet condensing, which is usual in American pumping engine practice, the air pump being 35 inches diameter by 24 inches stroke, and single-acting of the bucket type. In general design this engine approaches as near finality in compactness as possible, and could be easily doubled in capacity by arranging a set at each side of a central flywheel, the two sets working at 90° on to overhung cranks as in Fig. 19, and would then, as in that instance, present a type of rotatory pumping engine having a strong resemblance in its working to many of the non-rotative duplex class ; such engines having some advantage in being less subordinated to the structural arrangements required by flywheel and crank shaft than found in other types of rotatory engines.

CHAPTER IV.

WATERWORKS PUMPING ENGINES.

Direct-Acting Duplex Class.

A CLASS of pumping engine now very widely used in large central pumping stations consists of an improved form of the duplex direct-acting type, first introduced into this country in 1885, the underlying principle of which is the invention of Henry R. Worthington, who obtained a gold medal at the Centennial Exhibition, U.S.A., in 1876, and subsequently succeeded in getting it largely adopted by the American oil companies for pumping petroleum through the extensive pipe lines from the oil fields of Pennsylvania and elsewhere to the sea-board, owing to its smoothness of working and freedom from concussive action, an advantage obtained by utilising the piston movement of one engine to actuate the distributing valves of the other. Each complete engine consists of two separate sets of steam and pump cylinders, hence the term "duplex" used in naming pumps of this class.

Many waterworks and pumping stations in this country are equipped with modernised Worthington engines with compensating action. In describing this type of engine it is difficult to choose any one particular case among so many; a large installation in West Australia has, therefore, been taken as an interesting example—*e.g.*, the Coolgardie water supply, consisting of 20 high-duty pumping engines capable of delivering $5\frac{1}{2}$ millions of gallons of water through a main extending inland to the Gold Field District, a distance of 360 miles, and including several widely-separated townships; the whole of this plant having been supplied and installed by Messrs. Simpson & Co. This notable installation consists of eight stations distributed along this extensive pipe line at irregular intervals, increased difficulties having to be reckoned with in consequence of the tract laying across a waterless and extremely difficult country. The daily capacity of these engines amounts to over $5\frac{1}{2}$ millions of gallons in ordinary working, the water being pumped in stages through a steel pipe 30 inches diameter, against a total head, including friction, of 2,700 feet, the whole of the contract for completing this scheme, including all machinery, boilers, etc., having been carried out by this firm. *Appropos* of the indispensable desideratum for a daily supply of water in adequate quantity, it may be stated here that in this district, where gold has been found so plentifully, water has been known to be so scarce as to be worth actually 2s. for a single gallon previous to this plant being put down; now, thanks to Sir F. Forest and modern enterprise, a practically unlimited supply is available, and at a cost of less than 5s. per 1,000 gallons. In the construction of this pipe-line, let it be considered, over 60,000 separate pipes each 28 feet in length had to be properly laid and connected up, the weight of which, although averaging only $\frac{1}{4}$ inch thick, totalled up to 77,000 tons.

The engines which more closely concern the purpose of this treatise consist

of 12-inch triple-expansion horizontal Worthington's of the high-duty class, each engine having two high-pressure cylinders 16 inches diameter, two intermediate cylinders 25 inches, two low-pressure cylinders 46 inches, and two double-acting piston plunger pumps 15 inches diameter, each having a common

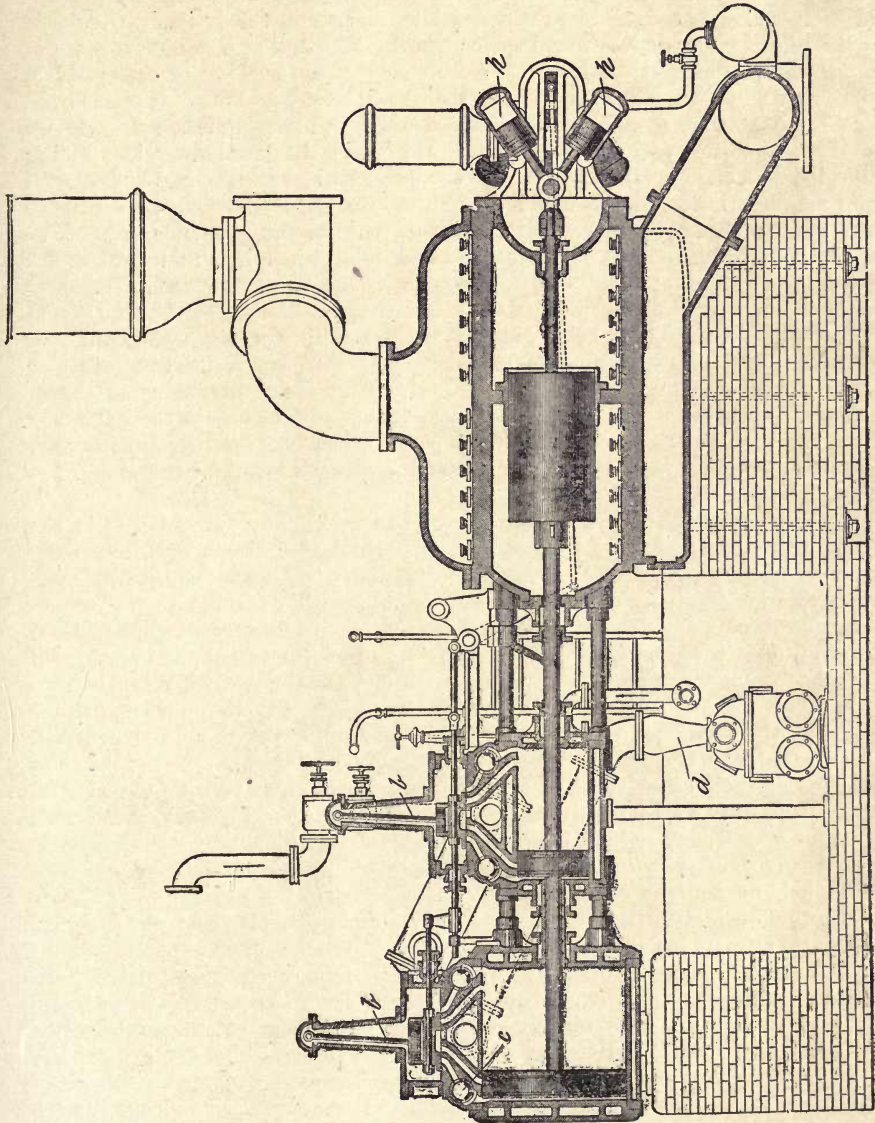

Fig. 21.—Section of Worthington High-duty Pumping Engine, showing Arrangement of Compound Steam Cylinders, Hydraulic Compensators, and Double-acting Pump.

stroke of 36 inches. In addition to these 12 engines, there are other 8 exactly similar in size, excepting that the pump plungers are made 21 inches diameter instead of 15 inches, these being used against a lower head. The indicated horse-power of each of these 20 engines works out at close on 300 when working

at their full capacity, and their general construction is very similar to the engine shown in Fig. 21. By means of plungers in the hydraulic compensators, as shown at *h*, sufficient power is stored during the first half of each stroke to enable the steam pistons to complete their full stroke after the steam has been cut off at from one-third to one-fourth ratio, and consequently fallen considerably below the average pressure, while, of course, the resistance opposed to the pump plungers has remained constant. The action of the two pairs of compensating plungers, so important for the efficient working of this class of pumping engine, will be gone into in further detail later on. It may be mentioned here, however, that, in combination with their use and an hydraulic safety device for destroying the vacuum, the engines are efficiently guarded against racing following on a sudden fall of pressure in the water main. It must not be gathered from the description of the working of these exceptionally economical engines that large pumping engines constructed on the duplex principle cannot be run without compensators, either on the hydraulic principle, as adopted in the Worthington high-duty pumping engines, or on the Heisler method of causing the cylinders to transmit a portion of their force from the side under full steam pressure to aid the other side, which is at this time working expansively, or again, as in the Odesse pumping engine described later, in which a compensating action is obtained by air pressure. The Holly duplex rotative engine shown by Fig. 19, it will be recollected, has also for its special object the balancing of the forces in the two sets of cylinders more fully when working expansively, and, indeed, this is the *raison d'être* of all the various forms of crank and fly-wheel pumping engines.

The advantage obtained by the use of the hydraulic compensators is the higher degree of expansion in combination with larger steam cylinders than found to be possible in duplex engines constructed without them. An interesting example of their efficiency can be stated with reference to the triple-expansion duplex engines put down in 1898 at the Grand Junction Waterworks at Hampton; these engines, having two sets of steam cylinders, 15, 23, and 36 inches diameter respectively, fitted with the usual form of Worthington-Corliss valve gear, and double-acting pumps of 22½ inches diameter; the stroke of these engines is 36 inches, and the number of double strokes per minute at which they can be worked 30, this giving a piston speed of 180 feet per minute, their capacity at this speed being 7½ millions of gallons per diem against a head of 150 feet. In order to prevent these engines from running at an undue speed on a sudden falling-off in the load or by mismanaged starting, a valve in communication with the condenser is automatically opened by a spring, held normally in compression by the pressure of the water in the delivery main acting on a governor plunger in a very simple manner, when the compensators also are put out of action.

One of the largest examples of Worthington pumping engines of the horizontal compound type was put down at the West Middlesex Waterworks in 1897, these having a daily output capacity of 18 millions of gallons against a head of 60 feet; the dimensions of the steam cylinders of these engines are 27 and 54 inches, and water plungers 39 inches, with a common stroke of 44 inches. In this case compensating cylinders are also used in combination with a variable cut-off gear on the high-pressure cylinder, together with a fixed degree of expansion for the low-pressure cylinder. These engines, on a sudden release of water pressure, as witnessed by the writer, are held in check to a very great extent indeed by the combined action of the compensators and hydraulic safety governor, as, with the extremely early cut-off used, the steam pistons

were incapable of completing the full stroke. Of course, as in all engines of the duplex type, the oscillation is quicker with a reduced load, but in this case, even with no water head at all, the pistons are cushioned so as to be prevented from concussion with the cylinder ends. In addition to these safety devices, an hydraulic governor, acted upon by the fluctuation of water pressure in the delivery pipe, and arranged to automatically control either the point of cut-off or the steam regulator, is very often adopted, thus making these engines still more independent of constant vigilance on the part of the engineer-in-charge.

The following data have been abstracted from Prof. Unwin's report on the working of an engine of this size:—Steam cylinders, 27 and 54 inches; double-acting ram plungers, 40 inches; stroke, 44 inches. Pump valves consisting of rubber discs held up to brass seats by brass discs and springs, the action of which is extremely smooth and efficient. The action of the pump plungers is, to a very considerable extent, assisted by the compensators, there being two hydraulic plungers for each cylinder 11 inches diameter, acted on by a pressure maintained at a constant of 120 lbs. per square inch. These engines, which are employed in delivering water from Hampton to Barnes, a distance of 9 miles, worked during the trials at a head varying from 50 to 65 feet; the mean speed of double strokes per minute was 17·6; the indicated horse-power, 296; the pump horse-power, 250, the mechanical efficiency being, therefore, ·84. The engine delivered over 19½ millions of gallons during the 24 hours under observation, the work done in this time equalling 106 millions per cwt.

The following notes are taken from E. A. Cowper's report on the working of a similar engine at the Metropolitan Water Board's New River District Station at Green Lanes, Stoke Newington. In this case the pressure on the compensator plungers was at the time of the trials 158 lbs. per square inch; the steam pressure, 80 lbs.; diameters of steam cylinder, 27 and 54 inches; water plungers, 28 inches; stroke, 42 inches; indicated horse-power, 330; pump horse-power, 301; mechanical efficiency, 91·5 per cent.; coal consumption, 2 lbs. per pump horse-power; and duty, 109 millions per cwt.

Pumping engines of the Worthington type have been supplied to most of the London pumping stations, in either vertical or horizontal form; of which the following particulars describe one of a pair of vertical triple-expansion engines, with quadruple single-acting plunger pumps, as illustrated by Fig. 22. In these engines the high-pressure cylinders are arranged over the intermediates, and together drive one single-acting plunger, the other being driven from the low-pressure cylinder. These engines are connected together in pairs by a beam, somewhat after the fashion of the Blake-Knowles pumps, and in this case two pairs of engines are arranged side by side to work on the duplex principle. There are thus for each complete engine six steam cylinders and four plungers; Corliss valves are used, as in the horizontal type, as well as the hydraulic compensators, for which there are eight plunger rams, the weight of the four sets of pistons, rods, and plungers being balanced in pairs by the two beams. One of these engines, tested at the West Middlesex Waterworks, Hampton-on-Thames, gave the following results:—Duty, 101 millions per cwt.; consumption per indicated horse-power 1·6 lbs., per pump horse-power 2·17 lbs.; mechanical efficiency, 73·6 per cent.; diameter steam cylinders, 18½, 29, and 45 inches; diameter plungers, 35 inches; stroke, 54 inches; the speed in double strokes per minute, 17·8. Total indicated horse-power, 288; total pump horse-power, 212; steam pressure, 77 lbs.; and mean lift of pumps, 51·4 feet. The engines worked with a total absence of thud or concussion, their action being so smooth as to be almost inaudible.

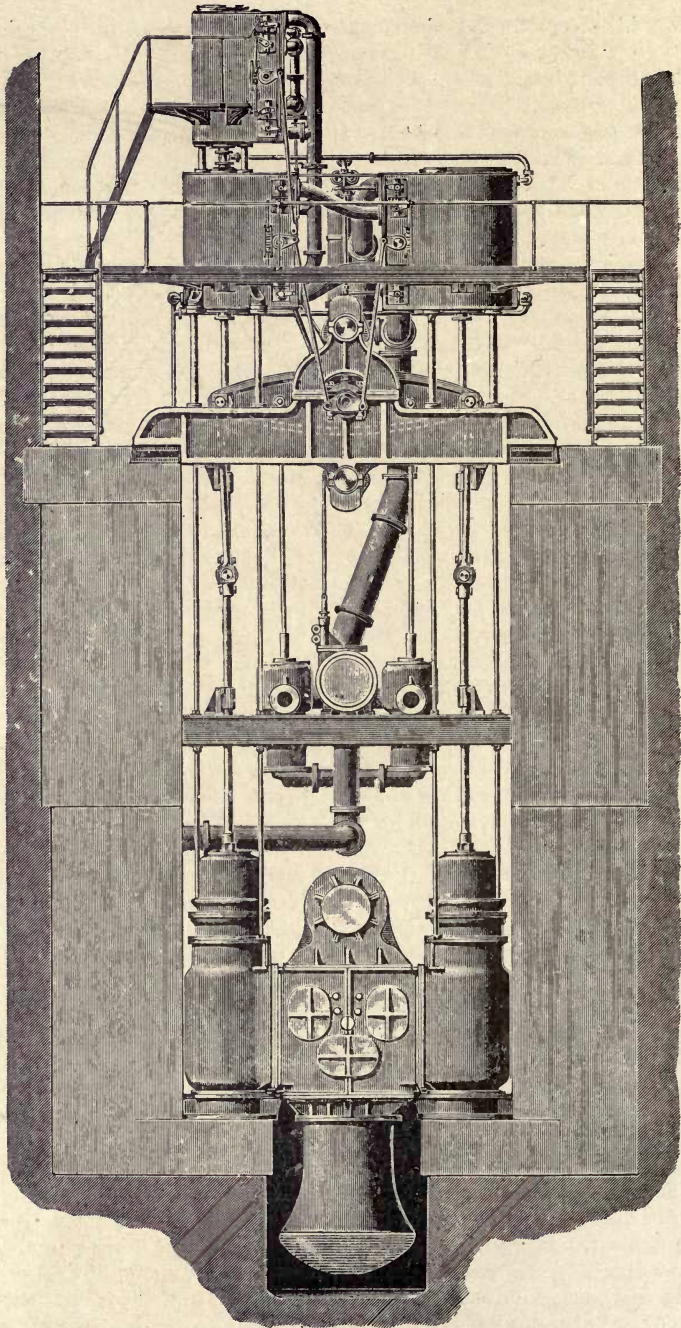

Fig. 22.—Sectional Elevation of Vertical Triple-expansion Worthington Pumping Engine, with Four Single-acting High-lift Pumps,

From observations made by the writer on the working of several large pumping engines of different types, there certainly seems to be a smoothness of action with engines of the direct-acting compensated class, both vertical and horizontal, which is rarely met with except in the highest class of three-crank flywheel engines. Duplex engines are, it is true, more sensitive to variations in load, and for this reason are not so well liked by some engineers for pumping direct into town mains, on account of the fluctuations of pressure to be met with, especially in cases where engines of different types are connected to deliver into a common main. This class of engine is, however, cheaper and much more compact than any form of crank engine can be, and, as an instance of their popularity, the Buda-Pesth Waterworks may be cited as being the largest pumping station in the world having engines of this class. The plant installed there for one of the main stations consists of six high-duty engines of the vertical type, each having a daily output of $6\frac{1}{2}$ millions of gallons. These engines are arranged to draw their supplies direct from the wells, four other engines of the horizontal type being used for raising the water to the necessary level (*i.e.*, to about 200 feet head) for supplying the town mains. To afford an idea of the enormous capacity of this station, it may be stated that the ultimate daily quantity of water to be raised from a double line of 100 wells, each 16 feet diameter, and extending along the bank of the Danube for a total distance of 8 miles, will be 53 millions of gallons per diem when completed.

The leading dimensions of these engines are as follows:—Steam cylinders, 18, 27, and 50 inches diameter; pump plungers, $22\frac{1}{2}$ inches diameter; stroke, 36 inches. Each engine is capable of delivering 6 millions of gallons per diem against a head of 243 feet, with an effective steam pressure of 160 lbs. per square inch and a piston speed of 130 feet per minute, the indicated horse-power being, therefore, in the neighbourhood of 300. The well-known Worthington construction is strictly adhered to, the two sets of three steam cylinders being arranged tandem wise, and the connections by single rods from the pump plungers to the low-pressure pistons, and double rods from the low-pressure to the intermediate-pressure pistons, and single rods again from the intermediate-pressure to the high-pressure pistons. This particular construction is followed to allow of the withdrawal of any one of the steam pistons without in any way having to dismantle the engine itself. Each cylinder is jacketed wherever possible, and to conduce to still further economy, the steam, in passing from one cylinder to the next, circulates through a tubular reheater, jacketed with live steam at full boiler pressure.

The valve motion of these engines is a modification of the Corliss type, the cylinders having two admission valves at the front and two exhaust valves at the back, the four valves being operated from a central wrist plate, which is actuated through the medium of links and rock shaft from the cross-head at the opposite side in the manner peculiar to this type of engine. The exhaust valves are opened and closed by links connecting the cranks on the valve spindle direct with the wrist plate, while the steam admission and cut-off valves are connected by links from their cranks to a secondary or arm crank fulcrumed on the wrist plate, and receiving its motion from its own side of the engine. By this arrangement the valves are opened by the motion imparted to the wrist plate from the opposite side of the engine, and are closed by a secondary motion derived from their own side of the engine; in this manner the cut-off can be made as rapid as desired, and all releasing devices, such as trip gears, are dispensed with.

The most important feature for the economical working of this class of engine

is the compensating action of the oscillating cylinders, previously referred to and now shown in diagrammatic fashion in Fig. 23. These cylinders are always

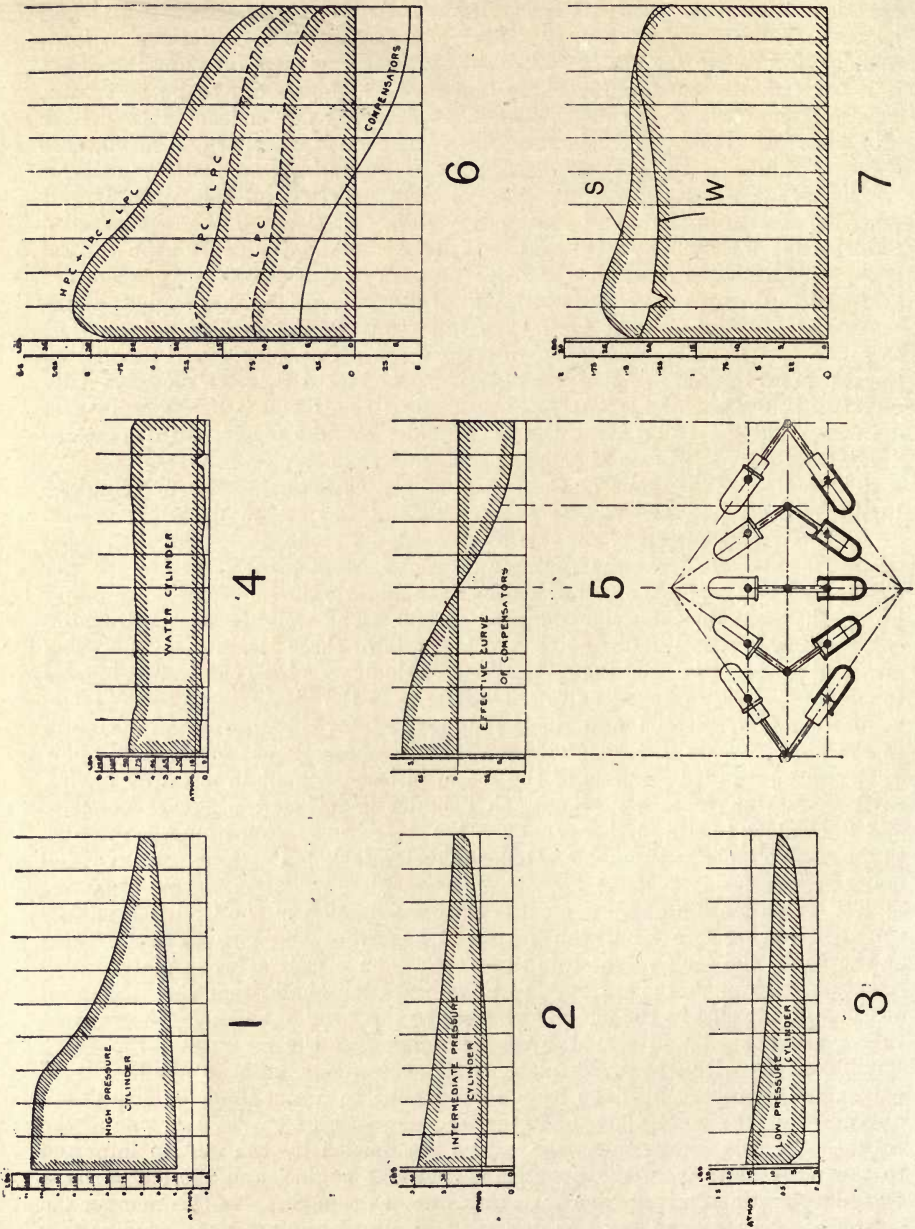

Fig. 23.—Steam Pump and Compensator Diagrams of Worthington High-duty Pumping Engine.

under constant pressure, so that the actual effect of the dual plungers on the piston-rod of the engine is determined by the various positions caused by the

oscillation at different points in the stroke. The diagram (view 5) shows the actual negative and positive effect of the hydraulic plungers. Diagrams 1, 2, and 3 are taken from the three steam cylinders; diagram 4 from the pump cylinder. Diagram 6 represents the combined effect of the three steam cylinders reduced to the area of the low-pressure cylinder only, the three-cylinder effects being shown superposed to form one diagram. Now, in diagram 7, the combined steam effect, minus and plus the effect of the hydraulic compensators, is indicated at S, this being the equivalent of diagram 6 modified by diagram 5. The line W in diagram 7 indicates the net pump cylinder resistance, and is the mean of the suction and delivery lines in diagram 4, the difference in the areas of S and W representing the mechanical efficiency between the indicated horsepower and the pump horsepower of the engine, and shows at a glance the proportion of power lost in engine friction. It will be noted that the net positive impulse effect, as indicated by the line S, is very nearly parallel to the line of resistance W, and, when allowance is made for the retarding and accelerating effect of momentum, this difference in parallelism will disappear altogether.

The closed ends of the oscillators H are connected by portways passing through the trunnions T to a central distributing chamber in communication with the differential accumulator A (see Figs. 24 and 25). From the diagrams 1, 2, 3, and 6, Fig. 23, can be seen the effect of the forces produced in the two sets of triple-expansion cylinders, both separately and collectively, and that the power absorbed and given out again by the equalising plungers H when subtracted from the left-hand side of the diagram and added to the right produces a propulsive effect of almost equally sustained force and nearly as constant in degree as the resistance opposed to the pump plungers. As the equalisers act in concert to resist the advance of the piston-rods of the engine during the first half of the stroke and assist it during the second half, and owing to their being placed opposite to one another, all lateral strain on the crossheads is obviated; at the beginning of the stroke when their angularity is greatest, the compensators exert their greatest influence, which gradually decreases as the steam pistons advance until at midstroke their influence is nil, then during the latter half of the stroke their action is in inverse order—*i.e.*, the power absorbed is again given back in an increasing ratio.

In order to limit the size of the compensating cylinders the pressure on the plungers is increased considerably above the pressure of the water in the delivery pipe by means of a differential accumulator, as shown at A, Fig. 25; to obtain this effect the accumulator ram is provided with a piston of about four times the area of the ram, and by this means the pressure acting on the compensator plungers is increased to the same degree. The top of the accumulator is in communication with the air bell B, consequently the action of the compensators immediately ceases in the event of the pressure in the service pipes falling away from any cause. An instance of this actually occurred with the 750 L.H.P. engines at the Brooklyn Waterworks, where the water main burst soon after the engines were first started, but resulted in the engines being almost immediately brought to a standstill, owing to the resultant inaction of the compensators and condensers.

In vertical engines of this type, the weight of the reciprocating parts is counterbalanced by hydraulic pressure acting upon the plunger rams R, which work in barrels situated directly under the pump-rod crossheads, as illustrated by Fig. 24; the double-acting piston plungers P being arranged below, and in order to economise space, are made cup-shaped to receive the lower ends of the balancing ram barrels R, and are connected to the pump-rod crossheads

by two pairs of side rods, partly shown in the sectional view of one of the pumps. The pressure required to obtain the necessary balancing effect is produced by compressed air, which is supplied by the same compressor as used for the air

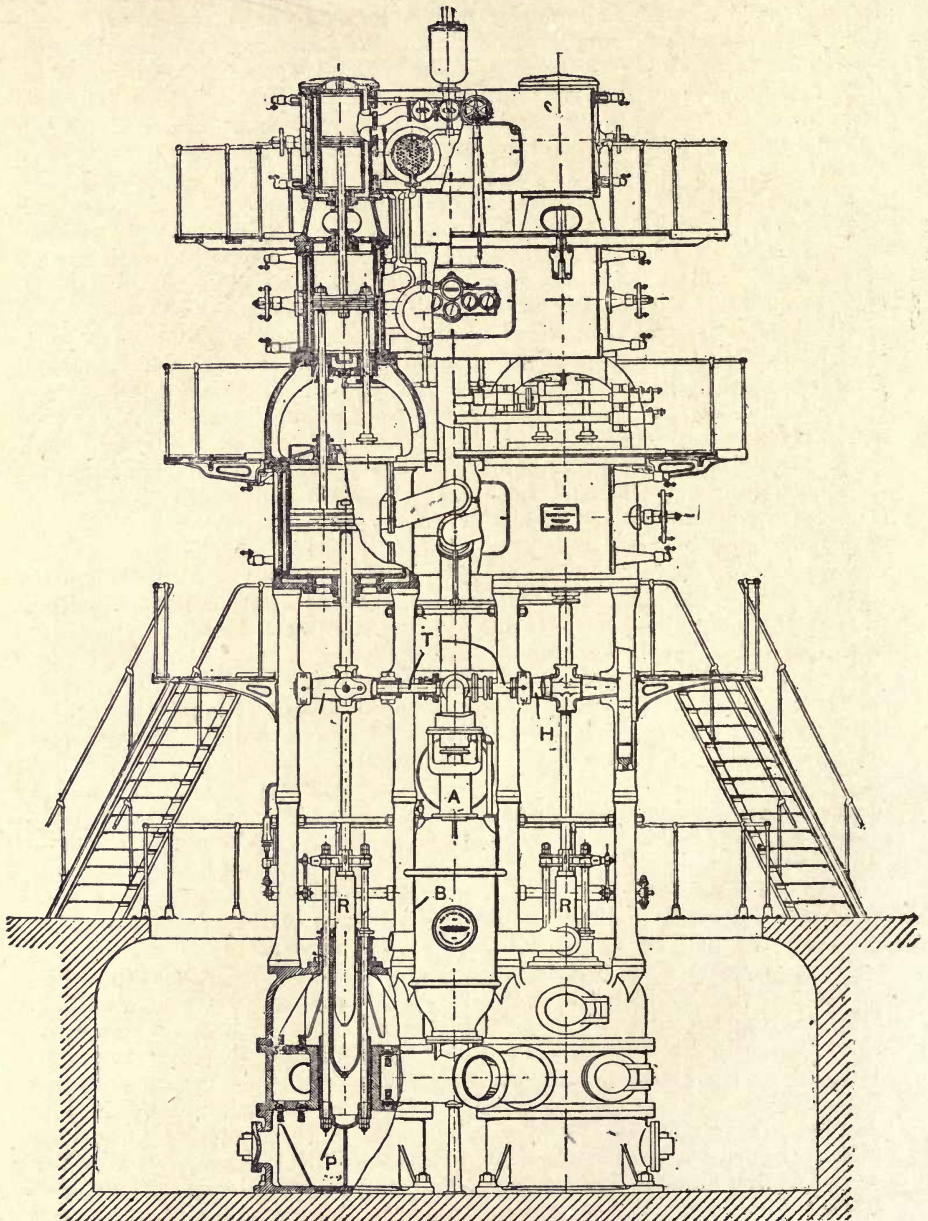

Fig. 24.—Section showing Arrangement of Steam Cylinders, Double-acting Air Pumps, and Hydraulic Balancing Plungers of Worthington Vertical Pumping Engine.

vessels and accumulator. In this manner, therefore, the entire weight of the vertical rods, pistons, and plungers can be floated so as to be exactly counterbalanced as desired, notwithstanding that the two sets of cylinders and pumps

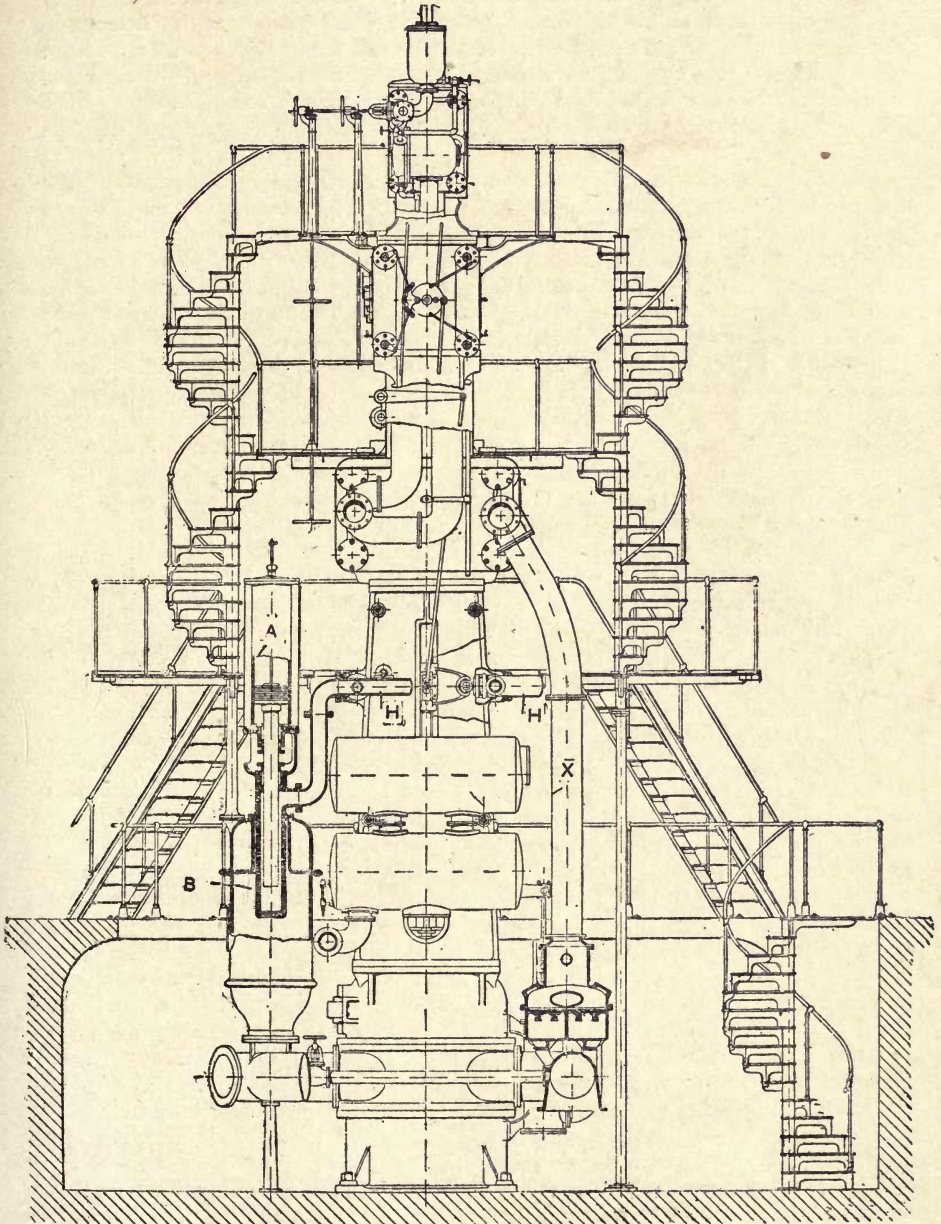

Fig. 25.—Section of Accumulator for Hydraulic Compensators of Worthington Vertical Pumping Engine.

constituting one complete engine, are, with the exception of their valve gear, entirely independent of one another. The valves used for the pumps of these engines are of the same rubber disc type as used for the horizontal engines, the area of waterway, both for suction and delivery, being approximately equal to the plunger area, and to this cause, in some degree, perhaps, may be attributed the marked absence of thud and water wump in their working as compared with crank engines running at an equal speed. The air pumps are actuated from beams connected directly to the main pump rods, a section of one of the jet condensers being shown by Fig. 25, where it will be recognised below the exhaust pipe X.

Turning now to American practice, we find much larger engines of the independently-balanced vertical type, as described and illustrated in the foregoing—the six sets at the Chicago Waterworks, for instance, have each a capacity of 18 millions of gallons per diem, and give a duty on trial equal to 144 millions per cwt. These engines have steam cylinders of 21, 33, and 60 inches diameter, and pump plungers of $34\frac{1}{2}$ inches diameter, with a stroke of 50 inches; other two sets of engines of exactly similar type are each designed to deliver 33 million gallons per diem, these being the largest direct-acting duplex engines of the vertical type in existence. Many other examples could be adduced, though sufficient has already been stated to give a very clear insight into the general construction and working of direct-acting pumping engines with hydraulic compensators in regard to their main features, yet, by entering more extensively into the various details making up the full construction of this very efficient, compact, and interesting machine, a great deal more might be said.

Duplex pumping engines without compensating action are made by the Dean Steam Pump Company and the Wilson-Snyder Manufacturing Company in both horizontal and vertical form, with triple-expansion, up to a capacity of seven millions of gallons per diem, but the arrangement of the steam cylinders in these engines is the converse to that adopted in the Worthingtons—*i.e.*, the low-pressure cylinders are situated at the end of the engine, then the intermediates, the high-pressure cylinders being arranged next the pumps. In the Dean, the low-pressure cylinder pistons are connected to cross-heads situated between the high-pressure cylinders and the pumps by double rods, which pass through the steam jackets of the intermediate-pressure cylinders and outside the high-pressure cylinders, the pistons of these cylinders being connected by single rods direct from the crossheads, an arrangement that does not appear to lend itself quite so conveniently for examination and removal of the pistons of the two sets of smaller cylinders. The steam distribution in the Dean pumping engines is generally effected by slide valves for the low-pressure and intermediate-pressure cylinders, the valves being balanced by pistons having pendulum rods, as shown at *b* in Fig. 21, while the high-pressure cylinders are controlled by a special form of Corliss valves provided with a variable cut-off gear; and in the Wilson-Snyder by piston valves. The pumps in these engines are not dissimilar to those already described, having double-acting piston plungers and multiple rubber-faced valves. In the Blake horizontal duplex mining engines the pumps are fitted with double-ram plungers, both ends outside packed, the two outend rams being connected to the rods carrying the steam pistons by side rods and crossheads.

Before concluding the consideration of duplex pumping engines of large capacity, such as required for distributing stations in large towns, there must be described another and equivalent form of balancing device, known as the Oddie compensator, which consists of an oil-sealed single-acting

air-spring plunger coupled to each of the two pump-rods through a system of toggle levers in such manner that power during the first half of the stroke is stored up in compressing a charge of air, which on again expanding during the second half of the stroke returns this power, thus equalising the thrust on the pump plunger during the whole stroke, and thereby permitting the employment of a higher range of expansion in the steam cylinders than would be possible without a compensator.

The construction of the air-spring compensator gear used in the Oddesse pump will be gathered from the sectional and diagrammatic illustrations, Figs. 26 and 27, in which (a) is an inverted plunger passing through the stuffing-box (b) into an oil chamber (c). On the downward stroke of (a) air under pressure is compressed between the surface of the contained oil and the space (d) under the hollow plunger (a), its lower edge remaining in continuous contact with the liquid below and is effectually sealed thereby. The motion of the air plunger is derived from a double pair of toggle links (t) connecting it with the pump-rod at a point between the steam and water glands of the pump, although obviously equally adapted to be connected to the pump-rod at either end. The toggle levers (t) are hinged to fixed fulcrums at (x), the two double links connecting midway to a bearing block at (y), free to slide in a stirrup (g), joining together the piston-rod and plunger crosshead, while the lower end is hinged at (z) to the air plunger.

In the sectional elevation (Fig. 26), the pump-rod is shown at mid-stroke, with the air plunger, therefore, depressed to its full extent against the pressure of air contained in (d), which, during the second half of the stroke of the pump-rod, is caused to expand, and in so doing to return a measure of energy stored during the compression of the air charge. The bottom-

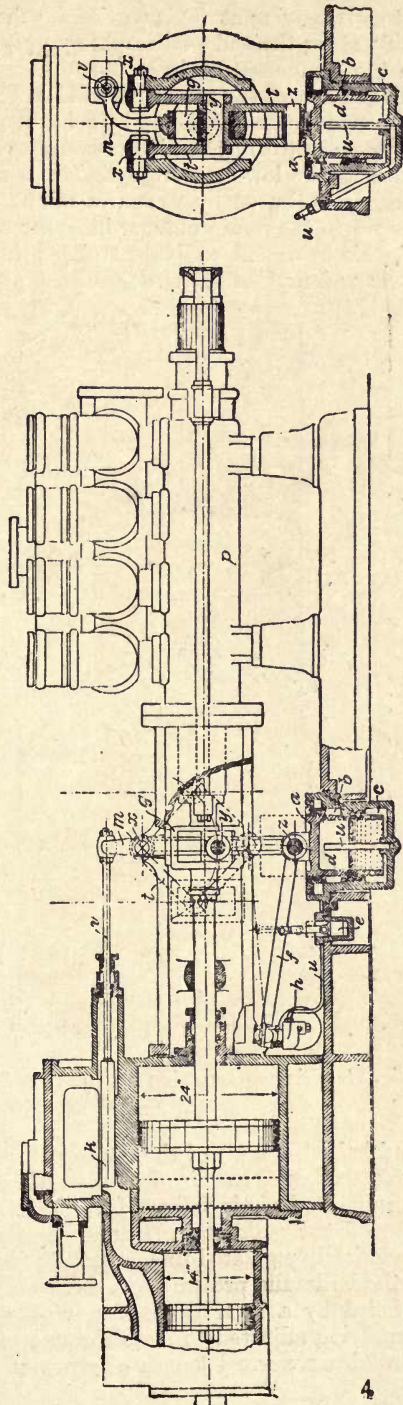

Fig. 26.—“Oddesse Compound,” 14 × 24 × 8 × 18 inches, Mine Pumping Engine, fitted with Air-spring Compensator.

end toggle bearing at (z) is carried by the radius rod (f), this bearing being free to slide along the end of the plunger (a); therefore, all end thrust is removed from the compensator piston.

The action of the air spring used in the Oddesse high-duty pumping engines will be made more intelligible by reference to the diagram, Fig. 27; in this, steam at a pressure (p) in the high-pressure cylinder is shown cut-off at (S), and expanded in the low-pressure cylinder to a point (x). By the action of the air spring, as indicated by pressures minus (c) and plus (c), the resultant thrust imparted to the pump plunger in either direction is represented by the pressure $p'x'$, this being the equivalent of $p-c$ during the compression stroke of the air plunger and first half-stroke (r) of the pump plunger, and to the corresponding

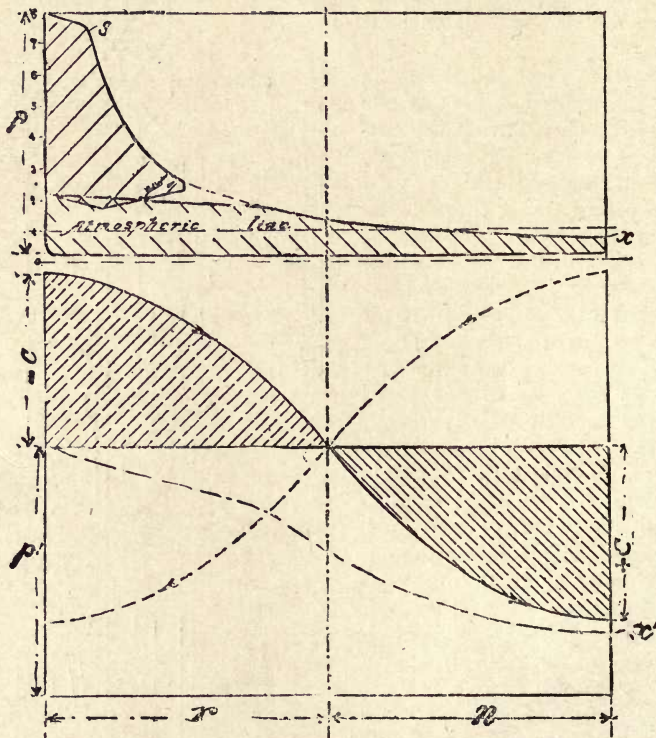

Fig. 27.—Diagrams showing Action of the Air-spring Compensator in an "Oddesse" Direct-acting Pump.

second half-stroke (n) of the pump plunger, by which it will be seen that there are two strokes of the air plunger to one of the pump plunger.

Compressed air is delivered at the required pressure by the small pump (e) driven off the radius arm (f), and can by a small relief valve shown at (h) be automatically regulated to compensate for the difference of mean steam pressure and the hydraulic pressure opposed to the pump plungers by a relief valve (h) controlled by a lever connection with the radius arm (f), the contact screw shown being adjusted to clear the end of the valve stem so long as the pump works with a normal length of stroke; but on the stroke of the main pump

exceeding this, the relief valve is opened to a corresponding degree by the increased oscillating action imparted to the radius arm (*f*), the opening varying as the stroke of the main pump exceeds normal.

The action of this form of compensator is thus seen to tend towards the maintenance of a constant length of stroke in the working of the pump under varying pressures, a most important feature in pumps of the direct-acting kind, as obviously any fore-shortening of the stroke results in steam waste due to increased clearances.

CHAPTER V.

DIFFERENTIAL NON-ROTATIVE PUMPING ENGINES.

PUMPING engines of the simplex differential non-rotative type are also largely used for purposes where large quantities of water have to be dealt with at high pressures, and owing to their peculiar construction are particularly adapted for working deep-level mine and well pumps, the differential horizontal engine having, it may be said, almost completely usurped the position once held by the vertical single-acting Cornish beam and Bull engines, to both of which the differential direct-acting engine compares to great advantage in respect of economy, more perfectly balanced action, and less first cost. Engines of this class are constructed with their steam cylinders arranged for working either compound or with triple-expansion all in one horizontal line, the piston-rod at one end connecting either on to a compensating oscillating disc or to the arms of a pair of quadrants, for the purpose of working deep-level pump plungers with a balanced action.

In connection with this class of engine there are several points of considerable importance—*e.g.*, the compensating method adopted for equating the power effect of the steam cylinders (when working with a high degree of expansion) to the constant load opposed by the pumps, combined with a differential controlling gear used in connection with the steam distribution.

In this class of pumping engine the power may be applied in direct line with a double-acting high-lift pump, or to low-lift pumps through a balancing motion, and comprise two distinguishing features—*viz.*, the method for controlling the steam distribution by a differential gear actuated by a secondary engine, and the method used for transmitting the motion from the piston-rod to a pair of deep-level pumps in such manner that the ratio of movement of the steam pistons in their relation to the movement of the pump plungers increases as the steam pistons advance towards the completion of each stroke, thus making it possible to use steam with a high degree of expansion; a result obtained in non-rotative beam engines by utilising the momentum of very heavy mechanism—by means of cranks and flywheels in rotatory engines and hydraulic compensators in high-duty duplex engines.

In describing the Davey differential valve gear used in these engines, it may be said to consist essentially of a small subsidiary engine, the speed of which can be regulated by means of a cataract cylinder to any desired rate, and of a pair of links having no fixed anchorage, but attached at one end to a rocking shaft and driven from and moving with the main engine, and at the other end to the small subsidiary engine. It is evident that, supposing the subsidiary engine and the main engine to be moving in opposite directions, a point at the centre of the links will not be moved exactly in accordance with either of them, but will have a mean or differential motion between the two. It is *ipso facto* from this central point that the valves receive their motion, and the arrangement is such that the valves are opened when the links are moved in the direction in which the subsidiary engine tends to move them, and closed when the links

are moved in the direction in which the main engine tends to move them. As before noted, the subsidiary engine is controlled by a cataract cylinder, and can, therefore, be set to move at a rate which will give the necessary valve opening when the main engine is working at any required speed, but directly this speed is exceeded, either let it be supposed from increase of steam pressure or decrease of load, the main engine will gain upon the subsidiary engine, the closing of the valves is accelerated, and as a consequence the steam is either throttled or cut off as the case may be; the gear, therefore, fulfils the additional function of a sensitive governor acting directly upon the steam valves. In combination with this subsidiary engine, there is a second small engine used to reverse the valve of the differential gear or first subsidiary engine; by this means the gear engine can be caused to make a pause after each stroke, and with it the main engine also, until the secondary engine has made its stroke. A second cataract cylinder enables the duration of the pause at the end of each stroke to be adjusted to a nicety, from a mere dwelling at the end of each stroke to a pause of 10 to 15 seconds or more, when for any reason it is desired to run the main engine dead slow.

However, in order to make the action of this gear thoroughly clear, it may be useful to append a description contained in one of Mr. Henry Davey's papers before the Institute of Mechanical Engineers, and can be better understood with reference to the four diagrammatic views A, B, C, and D, in Fig. 28. These views for clearness sake represent this gear as applied to an engine having only one cylinder, the subsidiary engine piston J being controlled by the cataract plunger K and the valve Q. The fulcrum P is assumed to be fixed in the following description, although it is in reality given a lateral movement by the second subsidiary engine referred to as being used to obtain the pausing action so essential for the smooth and efficient working of this class of engine.

The main slide valve G is actuated from the piston rod through a lever H working on a fixed centre, which reduces the motion to the required extent and reverses its direction. The valve spindle is not coupled direct to this lever, but to an intermediate lever L, which is jointed to the first lever H at one end; while the other end is jointed to the piston-rod of the subsidiary steam cylinder J, which has a motion independent of the engine cylinder, its slide valve I being actuated by a third lever N, coupled at one end to the intermediate lever L, and moving on a fixed centre P at the other end. The motion of the piston in the subsidiary cylinder J is controlled by a cataract cylinder K on the same piston-rod, by which the motion of this piston is made uniform throughout the stroke; also the regulating plug Q can be adjusted to give any desired time for the stroke. The intermediate lever L has not any fixed centre of motion, its outer end M being jointed to the piston-rod of the subsidiary cylinder J; hence the main valve G consequently receives a differential motion compounded of the separate motions given to the two ends of the lever L. If this lever had a fixed centre of motion at the outer end M, the steam would be cut off in the engine cylinder at a constant point in each stroke, on the closing of the slide valve by the motion derived from the engine piston-rod; but, inasmuch as the centre of motion at the outer end M of the lever shifts in the opposite direction with the movement of the subsidiary piston J, the piston of the cut-off point is shifted, and depends upon the position of the subsidiary piston at the moment when the slide valve closes. At the beginning of the engine stroke the subsidiary piston is moving in the same direction as the engine piston, as shown by the arrows in A, and in the instance of a light load as illustrated in B, the piston then having less resistance to encounter moves off at a higher

speed, and sooner overtakes the subsidiary piston moving at a constant speed under the control of the cataract; the closing of the main valve G is consequently accelerated, causing an earlier cut-off. But with a heavy load as in C. the engine piston encountering greater resistance moves off more slowly, and the subsidiary piston has time to advance further in its stroke before it is overtaken, thus retarding the closing of the main valve G and causing it to cut off

Diagrams illustrating action of Differential Valve Gear.

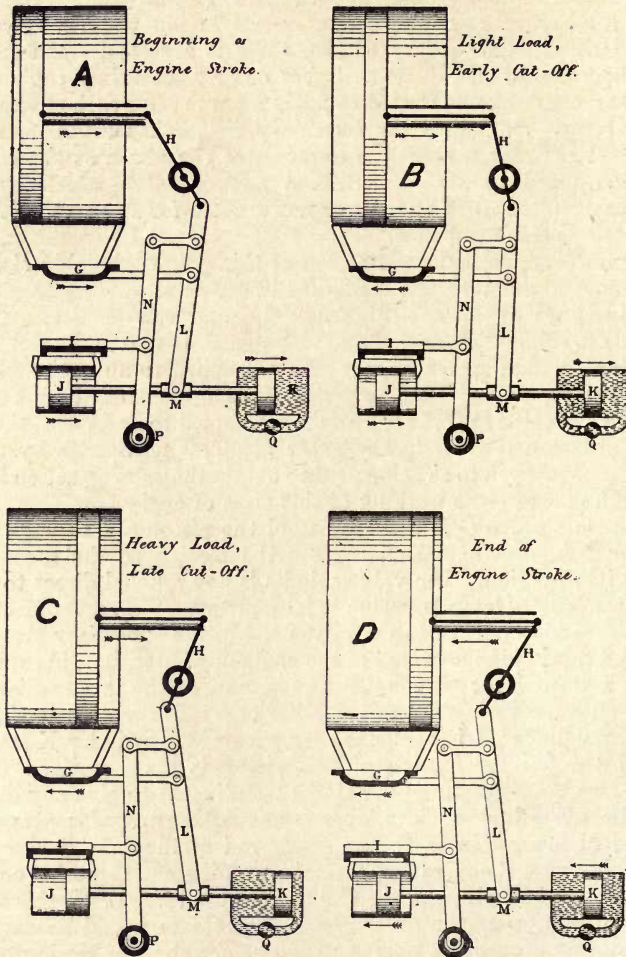

Fig. 28.—Davey Differential Valve Gear.

later. At the end of the engine stroke, as shown in D, the relative positions become reversed to that obtaining in A, in readiness for the commencement of the return stroke.

The force acting on the subsidiary piston J is much greater than that required for moving the slide valve, the excess being absorbed in driving the fluid in the cataract cylinder K through the small adjustable aperture Q; and as the

resistance of the fluid increases as the square of the velocity, a very small variation in the speed of the subsidiary piston can be effected by a considerable variation in the force upon it, so that the speed is maintained practically constant for a given adjustment of the cataract plug Q, although the boiler pressure of steam may vary. The main slide valve G is opened at the beginning of each stroke by the motion of the subsidiary piston, which is controlled by the cataract, and a pause is consequently given at the completion of each single stroke of the engine, and allows time for the large double-seated pump valves to settle on their seats. Slip in the water is by this means prevented, as well as concussion arising from the closing of the valves from a moving plunger. Freedom from shocks in pumps having long delivery pipes is an important point, and goes a long way towards the prevention of "bursts," in addition to giving a longer life to the engine.

In connection with the gear, as shown in Fig. 28, an independent steam starting or pausing cylinder is used to control the lateral position of the fulcrum P, the pausing engine being arranged below the fulcrum, which it controls by means of a rack gearing into a pinion on one end of a tubular shaft, the other end of the shaft being made with a screw thread, and by its rotation traverses the outer end of P of the lever N of the valve gear, and thereby opens the small slide valve I of the subsidiary cylinder J. The slide valve of the pausing cylinder is moved by tappets by means of a lever actuated by the same lever H that works the inner end of the intermediate lever L of the valve gear. The steam cylinder of the pausing or second subsidiary engine is itself also controlled by a cataract on the same piston-rod, and the length of pause after each stroke of the engine is consequently determined jointly by the two cataracts; the first regulating the time of opening the small slide valve I for starting the subsidiary piston J, after which this piston under the control of the other cataract has to travel a sufficient distance for opening the main slide G of the engine, the second cataract determining the mean speed of the engine under normal conditions of load and steam pressure.

The slide valve G of the high-pressure cylinder is provided with a couple of narrow ports through the back of the valve from end to end, as shown in Fig. 29, the effect of which is that, while the engine is pausing at the end of its stroke for the valve to be moved from mid position through the extent of the lap, a communication is established from one side of the piston to the other, so that, whatever the amount of clearance space left in front of the piston at the end of the stroke, it becomes all filled with steam that has just done its work behind the piston. This prevents the slight loss that would occur in having to fill the whole clearance with full boiler steam at the commencement of the return stroke; the initial steam has, therefore, only to raise the pressure in the clearance from the terminal pressure in the high-pressure cylinder, instead of from that of the low-pressure cylinder. A double-beat valve W is provided in the steam pipe, and actuated from the main valve spindle by means of a bell-crank lever and a pair of slotted connecting-rods X X, which are fitted with right and left-hand screws, and thus afford a ready means for adjusting the degree of expansion under normal conditions of working; the closing of the valve W also relieves the slide G from having to work under the full boiler pressure after the steam has been cut off. The slide valve Y of the low-pressure cylinder is balanced by means of a steel ring inserted in an annular groove Z on the back of the valve.

Simplex pumping engines with a differential valve gear on this principle are made by this firm with one steam cylinder (*i.e.*, to work on single expansion)

for purposes where a high economy in steam consumption is of secondary consideration, a case in point being an engine at the Kettering Waterworks, having a capacity equal to raising $1\frac{1}{2}$ millions of gallons per diem against a head of 40 feet; in this engine a double-acting piston-plunger pump is used, and as there is but the one steam cylinder the general design of this engine is exceedingly compact. For a water resistance involving a pressure higher than a maximum of 150 lbs. per square inch, the piston-plunger type of pump is not so suitable even with clear water, owing to the difficulty of avoiding slip. Messrs. Hathorn,

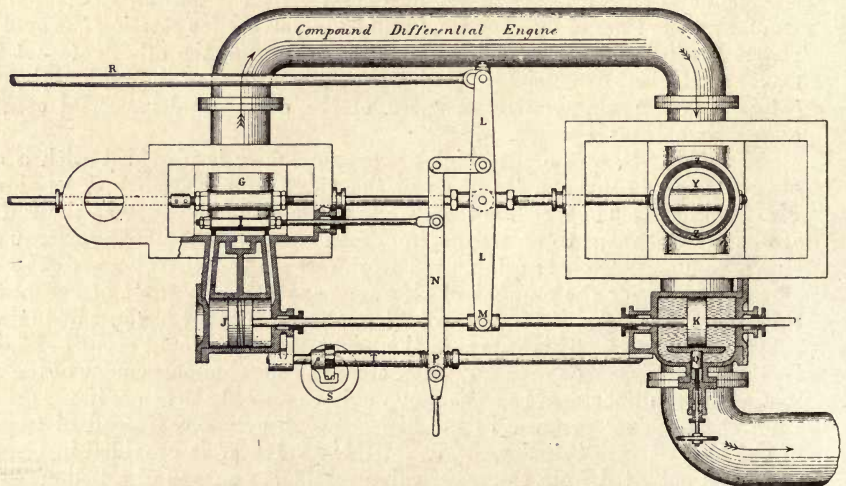
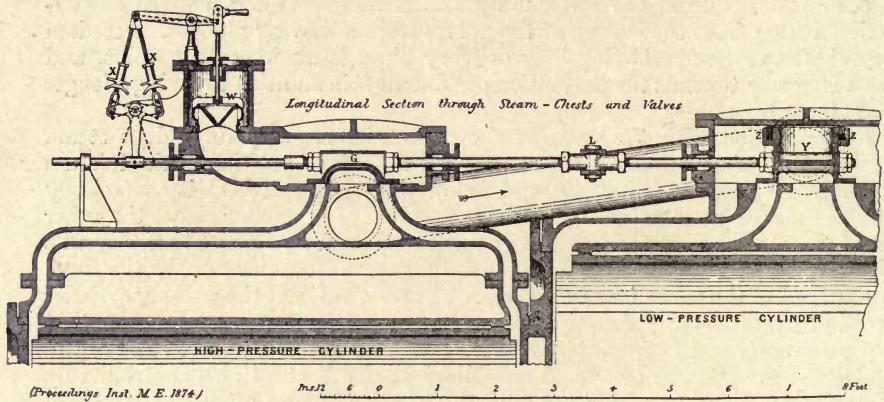

Fig. 29.—Sectional Elevation and Plan of Davey Compound Differential Engine, showing the Action of the Valve Gear.

Davey & Co. make compound and triple-expansion direct-acting engines with outside packed double-acting ram plunger pumps for dealing with the higher pressures involved in connection with mine drainage. An engine recently supplied to the Tranent Collieries, Scotland, may be referred to as a case in point, this engine being located 300 feet below the surface, and having to pump through 540 yards of piping.

However, engines of this class compare to more particular advantage in combination with a compensating high-duty balancing disc motion, the action of which transmission gear is illustrated clearly by the diagrammatic drawing, Fig. 30. Generally speaking, this high-duty attachment consists of an arrangement by which the steam pistons and pump bucket plungers are coupled

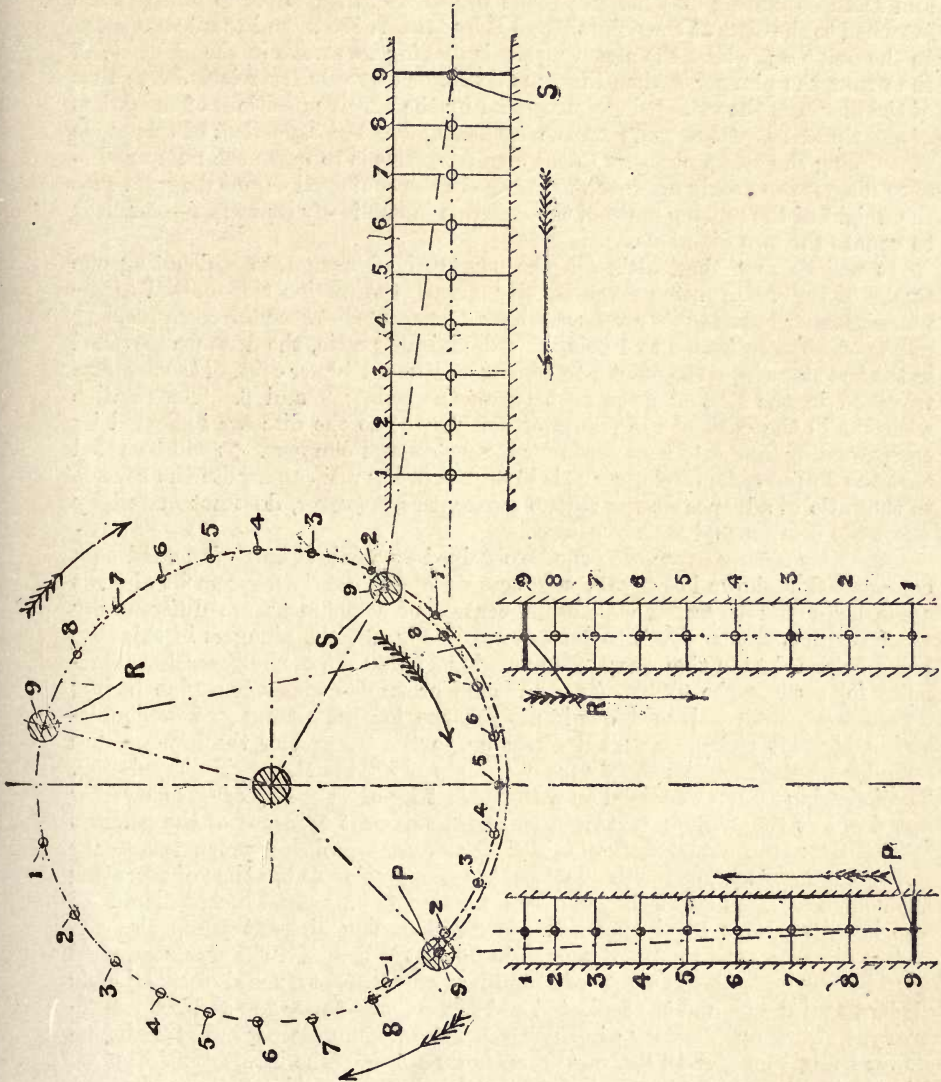

Fig. 30.—Diagram showing the Balancing Action of the Differential Pumping Engine.

together in such a way that the steam pistons get a mechanical advantage over the pump plunger as the stroke continues, in order to compensate for the gradually decreasing pressure of the expanding steam. For, whereas the force exerted by the engine piston decreases while the load is almost constant throughout the stroke, it is evident that the pistons must exert their combined force through

a distance constantly increasing relatively to the movement of the weight lifted, in order to be able to complete the stroke with a falling steam pressure, and to compensate for this effect means are required by which the steam pistons may move with a velocity varying relatively to that of the pump plungers. Referring now to the diagram, S is the steam piston, P and R the pump plungers, and D an oscillating disc moving about the centre E. The pump plungers are attached to the discs at the points P and R by means of rods, and the steam piston to the point S; whilst the steam piston is making its stroke in the direction of the arrow the plunger P then lifting is decreasing in velocity relatively to that of the piston S, the ratio being determined by the relative positions of the points of attachment P and R, and S on the oscillating disc D. The effect of this mode of coupling the pump plungers to the engine pistons is to make the pump resistance diagram so nearly approach the shape of the combined engine diagram that the weight of the moving parts of the engine is in itself—by its inertia—sufficient to equate the two diagrams.

It will be seen that, although the points of advance 1 to 9 denoting one stroke of the steam piston S are equally spaced, the motion transmitted to the pump plunger P during its ascent results in the spaces between the corresponding points of advance from 9 to 1 being in a diminishing ratio, the distance travelled in the last stage from the point 2 to 1 being only about 40 per cent. of the distance travelled in the first stage—*i.e.*, between the points 9 and 8. The relative positions in the path of the points of attachment to the disc are indicated by corresponding figures to those used for the piston and plungers. It will be noted that the down stroke of plunger R is in an increasing ratio and quite the reverse to the ratio of advance during the up stroke, this, however, does not materially affect the resultant advantage gained.

A similar differential motion can be obtained by a pair of balancing quadrants constructed as shown in Fig. 31: here instead of the usual arrangement of right angle bell-crank levers, the quadrant centres of attachment are differentially spaced with a similar effect to that shown in Fig. 29, the plungers in this case being balanced as in the other. The drawing Fig. 30 shows the general arrangement followed in the fixing of a compound or triple-expansion engine having differential action balanced quadrants for the low-lift pumps and a double-acting high-lift pump connected direct on to the tail-rod of the low-pressure cylinder which draws its supply from a pump alongside the engine foundation. The following results, obtained on a 48-hours' trial of an engine of this character put down at the Widnes Waterworks, afford sufficient evidence of the engine's capabilities: the actual duty obtained equals $109\frac{1}{2}$ millions, which is over 19 millions in excess of the requirements of the Corporation at the time of accepting the contract. This engine has two steam cylinders 32 and 60 inches diameter; two low-lift pumps $18\frac{1}{2}$ inches and one double-acting high-lift pump also $18\frac{1}{2}$ inches diameter, the stroke of each being 6 feet 6 inches. The water pumped per 24 hours is slightly in excess of $2\frac{1}{2}$ millions of gallons at a speed of 12.5 double strokes per minute, and the indicated and pump horse-power 230 and 200 respectively, showing an efficiency of 87 per cent., the steam used per indicated horse-power being 15.6 and 18 lbs. per pump horse-power. The illustration, Fig. 31, represents one of six sets supplied to the South Staffordshire Waterworks, and has cylinders 20 and 30 and 44 inches diameter; two borehole bucket plunger pumps and one double-acting piston-plunger pump, all of $15\frac{1}{2}$ inches diameter, the stroke common for both steam and water being 5 feet. The well pumps are placed at a level of 300 feet from the surface, although the actual lift required is only 67 feet; the high-lift pump, however, instead of having to do less than

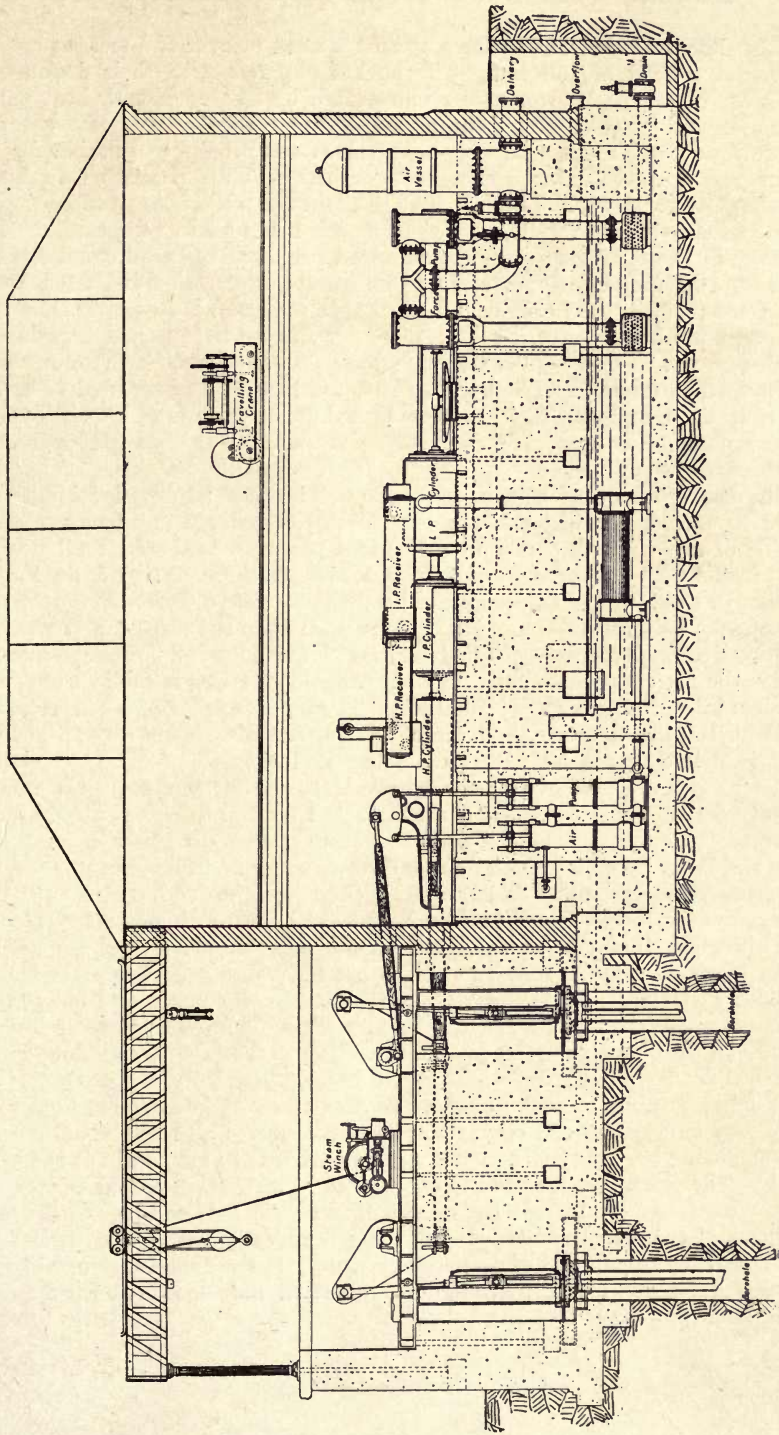

Fig. 31.—Davey Triple-expansion Differential Pumping Engine.

half the duty intended has to force against a head of over 320 feet, as against the contract head of 160 feet. The bucket plungers with their double-beat valves are of a type approximately represented by Fig. 34, double-beat valves being also used for the high-lift pump, and are found to work very satisfactorily. As previously pointed out, double-beat valves are peculiarly suitable for use in pumping engines having a slow beat, or better still if permitted a pausing period at the termination of each stroke. A 24-hours' trial of one of these engines afforded the following results, every precaution being taken to obtain absolute accuracy in the readings:—Gallons delivered per diem against a total head of 393 feet, 1.57 millions; equivalent pump horse-power, 129; indicated horse-power, 163; efficiency, 79 per cent.; steam per indicated horse-power, 14.3 lbs., and per pump horse-power, 18 lbs.; duty per cwt. on a 10 per cent. ratio, 123 millions nearly. These results, although good, do not show so high an efficiency as obtained in triple-expansion three-crank rotatory engines as used in water-supply stations, and may be in part accounted for by the use of low-lift bucket-plunger pumps having a restricted water-way seldom exceeding 40 per cent. of the area of the plungers.

The description of this class of engine, so well adapted for deep-level pumping, would be incomplete without some particulars of a large mining installation capable of dealing with 8 millions of gallons per diem against a total head of 2,000 feet, which has been equipped by Messrs. Hathorn, Davey & Co. for the Tasmanian Gold Mining Company:—This plant consists of three units, each unit consisting of a differential pumping engine placed upon the surface, and arranged to actuate through a pair of coupled quadrant levers four pairs of plunger pumps fixed in the shaft in such a manner as to be capable of raising $2\frac{1}{2}$ millions of gallons per diem in four stages, each of 500 feet. The engines are compound, receiving steam at 150 lbs. pressure, and are of exceptional dimensions—*e.g.*, the high-pressure cylinders are 50 inches diameter, and the low-pressure 108 inches diameter, with a stroke of 10 feet. The valves used for the steam distribution are of the double-beat type, and are actuated by the differential gear above described. Each engine is fitted with a separate surface condenser, having brass tubes and brass tube plates and independent air pumps. The pump work proper is of an exceedingly massive and interesting character, the quadrants, for instance, have arms each 15 feet centre to centre, and are built up of steel plates blocked with pitchpine, the main quadrant bearings being 18 inches diameter and 24 inches long. The spear rods themselves are 22 inches square, and in lengths of about 47 feet, the joints being made with steel spear plates and bolts in the ordinary manner. The pumps are fitted with outside packed ram plungers, each 20 inches diameter by 10 feet stroke. The valves are of the double-beat type, but arranged in multiple in separate boxes, there being eight suction and eight delivery valves to each plunger. By this means it is possible to get a full water-way and still to use comparatively small valves and small valve boxes, no part being too heavy to be readily dealt with by one man without the use of tackle. The rising main, which is of steel, is 16 inches internal diameter, and has welded flange joints. As the weight of the spear rods and plungers is much in excess of the water resistance, balancing beams are arranged on each level, and relieve the quadrants of unnecessary strain; the working efficiency of these engines is 83 per cent. in relation of indicated horse-power to the actual or water horse-power.

CHAPTER VI.

MINE-PUMPS, FORCE-PUMPS, AND SINKING-PUMPS.

THE necessity for draining tin mines and coal pits may be said to have been primarily responsible for the introduction into use of deep-level steam-actuated pumps, these being in the earlier stages all worked from engines located at the head of the pit shaft. Pumps of the bucket type with leather-packed plungers provided with leather-faced flap valves, as shown in Fig. 32, were at first principally used, the water head for each pump not generally exceeding 300 feet. On the introduction of improved engines, such as the Cornish beam single-acting class, ram plunger pumps were found to be more suitable, these lending themselves, together with the heavy spear rods used to connect the engine beam to the pumps, to obtain a complete balance of the water column in the rising main. Ram plunger pumps are even to this day more used than any other type in deep-level mines, owing to the greater facility of access to the valves, and to their being easier maintained in water-tight condition. In some instances, it is true, bucket plungers may be advantageously used to pump the water up the first stage, ram plungers being used to force the water from a sump, or from the head of the bucket plunger, as shown in Fig. 32, to the surface in one or more stages, according to the depth of the mine, a leap of 500 feet being seldom exceeded in one single stage.

In all the earlier types of non-rotative beam engines the usual practice was to connect up the pumps in series from one end of the working beam, the down stroke being performed entirely by the weight of the rods and plungers; the time taken for this was usually much longer than the up or steam stroke, this being done, as before explained, in order to obtain a more expansive working of the steam. For this reason it was customary to provide two valves for the suction or indoor strokes of a type similar to the annular-seated valve illustrated by Fig. 54, and one for the delivery or outdoor strokes; this form of valve, it may be stated, greatly contributed to the successful working of this class of engine. In the more modern method adopted of employing two sets of pumps actuated from spear rods which are connected to the arms of a pair of balancing quadrants, as shown in Fig. 31, a much smoother action is obtained, the engine being usually of the horizontal double-acting simplex type, of which the Davey differential pumping engine above described may be taken as a good example. Other reasons for using ram plunger pumps for draining mines are the following:— (1) They are less liable to become choked; (2) are more accessible for examining the valves; and (3) are easier to keep water-tight; although for low-lift pumps located in wells or boreholes for water-supply stations and the like, bucket-plunger pumps are employed under most circumstances, whether the actuating engine be of the rotative beam, simplex horizontal, vertical rotatory, or geared three-crank type. In usual pitwork practice a single ram plunger pump, as shown at (a) in Fig. 32, is put down, unless the mine exceeds in depth 400 to 600 feet, and is the type of pump adopted in connection with most of the early

*Cornish
Pitwork,
Plunger Pump*

*Ordinary Plunger
and Bucket Lift.*

Inverted Ram Pump.

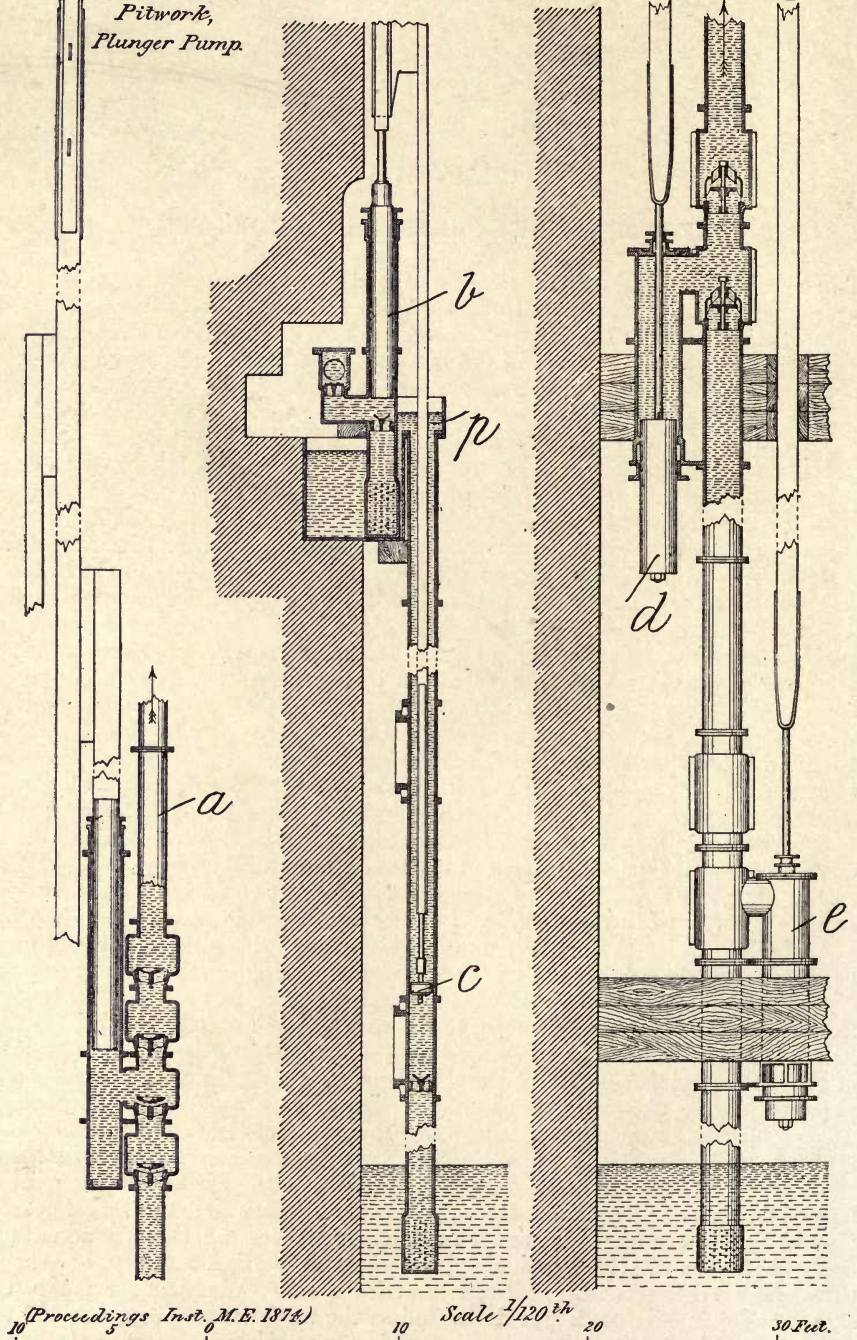

Fig. 32.—Typical Deep-level Mine Pumps.

direct-acting beam pumping installations. A later form for deep levels is, as shown at (d) and (e), this arrangement having the advantage of permitting the water to be lifted in stages, the lower pump discharging into the upper pump, thus halving the pressure on the plungers and delivery valves; although the plungers are shown inverted—a disposition that has some advantages—a similar series effect can be obtained with the direct form of ram plunger pump, the plungers in either case being connected to move in opposite directions.

Another form of relay pump is illustrated by (b) and (c), Fig. 32; in this example the low-level pump (c) is shown fitted with a bucket plunger, and to deliver into a sump (p), from which the upper pump (b), which may be fitted with either a bucket plunger or a ram plunger as shown, delivers the water to the pit-head. This is a method commonly adopted for deep levels, pumps being often placed in as many as four stages, at from 300 to 500 feet intervals.

In the form of ram plunger pump illustrated by Fig. 33, no foot valve is required other than the valve (v) fitted to the upper end of the hollow plunger (r), which is thus in part utilised as a suction pipe; the purpose in view for adopting this construction is to be able to withdraw the foot valve together with the plunger.

The form of pump commonly used for high lifts is one known as the bucket-and-plunger pump, which consists, as shown in Fig. 34, of a combination of ram plunger (P) and bucket plunger (K), the latter, of course,

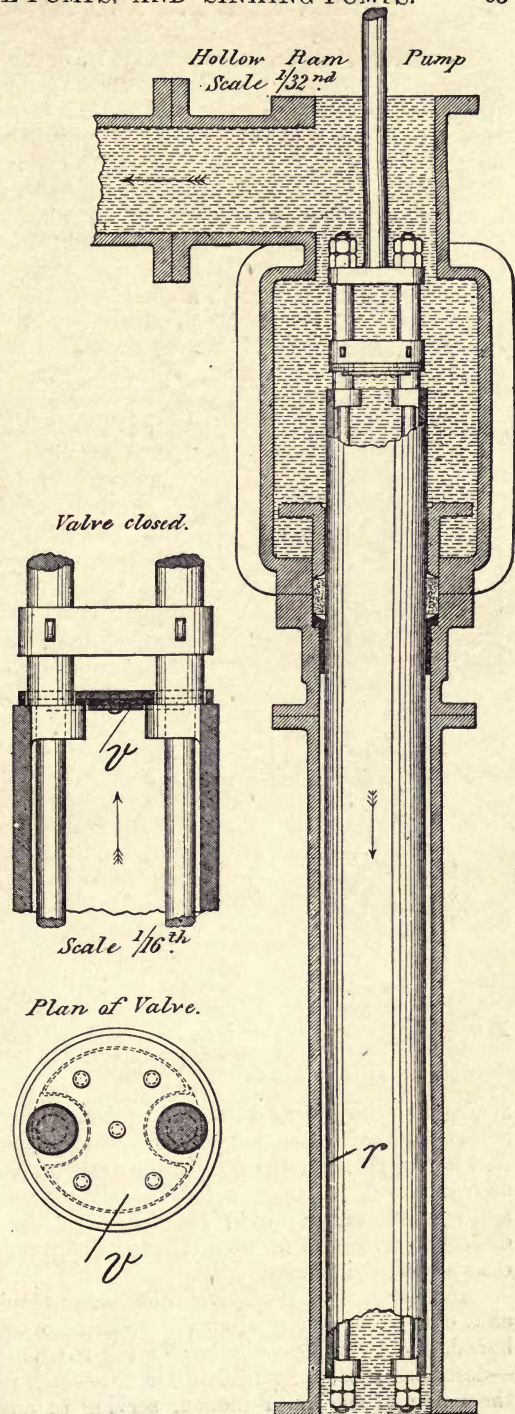

Fig. 33.—Hollow-ram Mine Pump.

being provided with a valve arranged to open on the down stroke; this type of pump acts as follows:—On the up stroke the bucket draws water through a foot valve, and on the down stroke this water is forced to the upper side of the bucket, (K), and it follows that as one-half the displacement above the bucket is caused by the ram plunger (P), one-half of the water so displaced is forced into the rising main, the other half being delivered on the up stroke; there is thus an equal rate of delivery at each stroke, although the pump is single-acting in regard to suction, and consequently only delivers a volume of water equal to the displacement of the single-acting bucket plunger. A similar effect can obviously be obtained with a combination of piston plunger and ram plunger; in this form of differential pump, however, water instead of passing through valves in the plunger, is forced through a passage outside the barrel to the space above the solid piston plunger, a ram plunger being used at the delivery end of the pump, as in the bucket-and-plunger type of pump. This form of pump was first used by Sir William Armstrong as an hydraulic pump, who used the rod as a ram plunger.

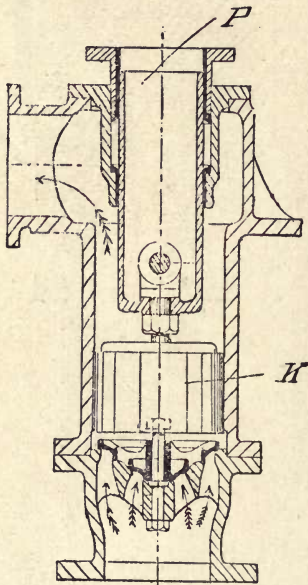

Fig. 34.—Typical Plunger and Bucket Force Pump, with Triple-seated Ring Valves.

A differential pump can also be constructed with two ram plungers, one of which is of twice the area of the other; the larger ram is single-acting, and forces at each down stroke half its displacement into the water space around the smaller ram, and half into the delivery main direct, and is a form of pump, as in the two former variations, that affords the advantage of a double-acting delivery with but two valves; whereas with a double-acting ram plunger pump, as shown in Fig. 35, two suction valves (*n*) and two delivery valves (*d*) are required.

A form of force pump that is entirely without foot valves is sometimes used for liquids containing solids liable to choke the valves; in pumps of this kind, which usually have two or three single-acting bucket plungers, the liquid is caused to pass through each bucket in succession, and consequently at twice the velocity for the same plunger speed as in an ordinary pump. In construction the top of each barrel is connected to the underside of the one next to it, and in action as the first plunger descends after a suction stroke, its fellow ascends, and thus draws water into the second barrel; on the second plunger descending, the first plunger ascends, and forces water from the first barrel through the connecting water-way and descending plunger into the second barrel, and thence to the delivery outlet; this pump is thus double-acting, although requiring for this effect two plungers, each provided with delivery valves, which, as in the form of pump shown by Fig. 33, can be withdrawn with the plungers.

Another form of deep-level force pump requiring no foot valve is that known as a concertina pump, from the to-and-fro action of two plungers in a single barrel, and thus is peculiarly adapted for borehole wells. In this useful pump—described more fully in Chapter IX.—each plunger is fitted with a lift valve, the valve in the lower plunger serving to admit water between the plungers

on the receding stroke, and the valve in the upper plunger opening on the in-stroke, thus the pump is double-acting at the delivery end, and delivers a volume of water equal to the combined stroke displacement of the two plungers, which are connected by quadrant levers, as shown in Fig. 31, the connection to the lower plunger being by a solid rod passing up through the upper plunger, which in turn is connected to one of the quadrant levers by a tubular rod.

There is another particularly useful form of pump for raising water from deep wells in connection with continuous town supply, which is notable in having both the suction and delivery valves carried in the plunger. Pumps of this type are provided with a double hollow plunger, the lower of which works in a barrel with a closed end, and is provided with inlet valves opening inwards, while the upper plunger is provided with a ring delivery valve; the annular space separating the divided plungers is placed in communication with the suction pipe, the action of the pump being as follows:—On the up stroke water is drawn into the closed lower barrel through the series of valves in the neck separating the two plungers, and is displaced during the down stroke through the delivery valve in the upper plunger, when again on the succeeding up stroke the water so displaced is forced into the rising main. In a modified pump of

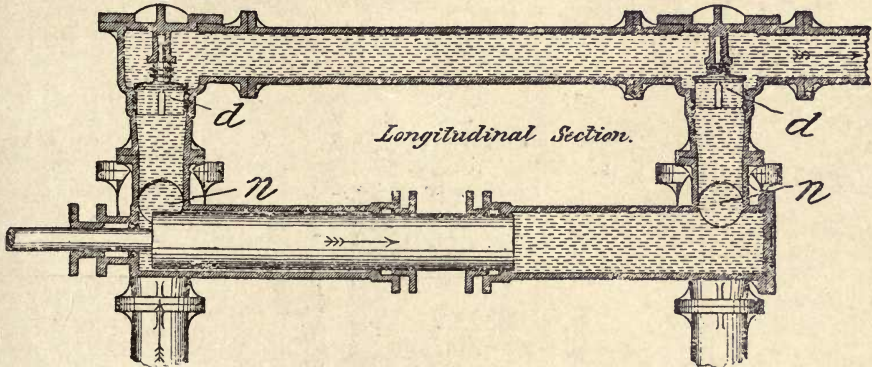

Fig. 35.—Double-acting Ram Force Pump.

this kind, known as the Ashley, *vide* Fig. 36, the double plunger is separated by a waist having an internal area of half the area of the plunger, which waist is cast in one piece with the plungers, and is of hexagonal form, each facet containing a row of small inlet valves *S V*, and the upper plunger with a double-beat delivery valve *D V*. In this form of pump an almost unlimited waterway can be provided by employing a number of inlet valves, and as the plunger speed of all pumps is limited to the velocity at which water will follow the plunger, it will be seen that a higher speed can be obtained with a pump of this form than with a pump using the ordinary foot valve; its principal advantage, however, consists in the ability for both sets of valves to be drawn up for examination or renewals, there being no foot valve required.

The Ashley pump, although represented as a 3-throw pump, is equally well adapted for being worked in pairs from balancing quadrant levers or otherwise. The particular set of pumps illustrated, represents one of a pair that have been supplied to the Brighton Corporation Waterworks; and are actuated direct from a vertical 3-crank triple-expansion engine at 25 revolutions per minute, at which speed they are capable of delivering 2,250,000 gallons per diem into

a sump 170 feet above the level of the water in the well where the pumps are fixed to girders built in the walls. The diameter of the pump barrels is $15\frac{1}{2}$ inches,

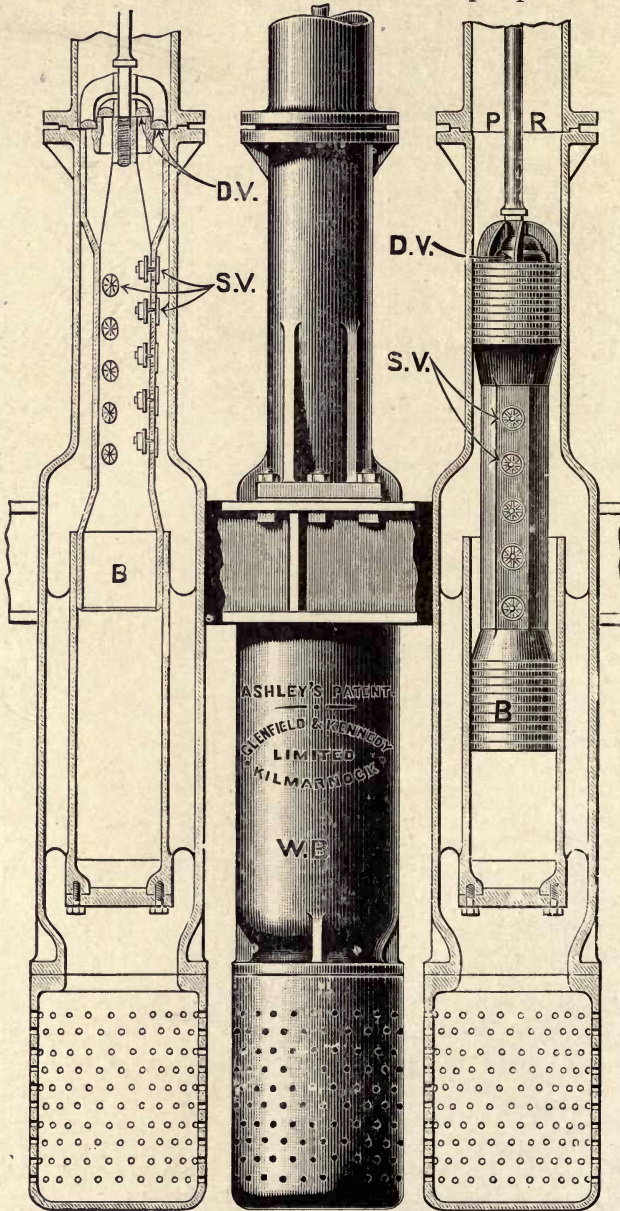

Fig. 36.—Ashley Deep-level Pump.

and the stroke 2 feet 6 inches, the plunger speed thus being 125 per minute. Altogether there have been eight sets, ranging in size from 8 to 23 inches diameter,

supplied to these works, and a further six sets to the East London Waterworks of similar type, but arranged with inlet openings in the waist of the shrouded jacket around the barrel, the pumps in this case resting on a pedestal bolted direct to foundations in the bottom of the wells 200 feet down.

The particular interest attached to the Ashley pump is in the form of the plunger, with its double piston and series of multiple suction valves placed between them, it being recognised that the speed limit to pump plungers is influenced to a greater extent by the available area of waterway in the suction inlet than by any other cause; in this rather unusual form of plunger, the construction is such as to afford a waterway capacity of any desired extent, and as the valves are situated at a point high above the bottom of the pump and are contained in the plunger itself, not only is there less liability of the valves being choked with sand or from other causes, but the pump is thereby adapted for being placed lower down in the well; and, moreover, owing to the fact that both suction and delivery valves are contained in the plunger, the whole can be removed at one operation. The plunger, as will be noted, consists of two water-tight pistons cast in one piece with a connecting throat of hexagonal form in which are inserted a series of brass seatings containing rubber disc suction valves S V, a multiple-seated delivery valve being fitted at the head of the plunger, having two annular waterway passages resembling closely the construction shown in Fig. 34; the upper end of the bucket is precisely similar to the ordinary pump, but the lower end, on the contrary, is seen to be quite free and open. The working barrel may either terminate in a suction rose, as shown, or the inlet for the water may be through openings in the jacket, the pump then resting on the bottom of the well without side supports; a point not to be overlooked is the location and arrangement of the inlet valves which escape much of the trouble liable to be caused by grit or sand, no very serious consequence resulting even if one or two of the valves do get temporarily held up.

The pumps so far described are worked by surface engines. There is, however, a growing practice to place electrically-driven pumps of the horizontal 3-throw type close down to their work, there being less loss in transmitting the necessary power by means of cables than has been experienced with carefully insulated steam pipes. The electric motors used for this purpose are obviously both water and spark proof, pumps of this type being found to afford a most convenient means for removing accumulating water, especially in such cases where they are not required to be constantly in use; and, further, as in many mines there is an electric installation for lighting the various galleries already put down, much of this plant can be brought into service for pumping purposes.

Another method now also being employed for pumping out water from deep levels is by high-lift centrifugal turbine pumps directly driven from electric motors. Centrifugal pumps with impeller wheels arranged in series on the turbine principle, although not so efficient as plunger pumps, have the great advantage of being far more compact and easier fixed; also, high-lift pumps of this class constructed in multiple series are now guaranteed to work with efficiencies up to 70 per cent. in raising water against heads up to 500 feet, the pumps being usually arranged in stages for lifts higher than this.

A suitable form of oil or gas-driven pumping set can also be used with excellent results, both in regard to economy and freedom from breakdown, the modern oil-fuel-engine gear-driven pumping set, now being considered to have an economical advantage over steam, or even gas, especially when only required to work intermittently. When required for use down in a coal pit, an oil engine must

obviously be constructed to start and work without the application of a flame, and, moreover, no part of the combustion chamber or exhaust pipe should be allowed to exceed a temperature of 700° to 800° F., in order to be entirely immune from any risk that may arise from the occasional explosive atmosphere of a coal mine. In the writer's experience a Butler oil engine of 20 H.P. made in accordance with the above standard has continued to work in a very satisfactory manner over a period of twenty years, pumping against a head of 500 feet at the Spring Well Colliery, Durham; this pump, however, is only used for temporary working, the time rarely exceeding 25 to 30 hours per week.

Apparatus for removing water percolating into wells, mine shafts, and other excavations during sinking operations—known as sinking pumps—constitute one of the most useful of all pumping appliances. Sinking pumps are made in many varieties, which may be roughly classified as follows:—(1) Steam plunger pumps; (2) electrically-driven centrifugal or turbine pumps; (3) pulsator pumps. Such pump in order to be adapted for this purpose must necessarily be entirely self-contained and capable of working without excessive vibration in a suspended position. Pumps of this class are usually provided with a telescopic suction pipe having a range of adjustment of a pipe length to enable the pump to be adapted to its work without having to be lowered for shorter distances. In large steam sinking pumps an exhaust pipe is usually carried up to the surface in addition to the steam and water delivery pipes, although for small pumps it is convenient to turn the exhaust into a condenser box forming a part of the suction pipe, a practice quite common in the States for sinking pumps of all sizes; by this means the pipe connections are reduced to that required in pulsators. It is owing to the simplified piping connections required in electrically-driven sinking pumps that they have such an advantage, there being in these practically only one pipe, and that a water pipe, which being cold is more convenient for piecing up than hot steam pipes.

The largest sinking pumps known to the writer are the Denaby-Davidson steam pumps, these being supplied in sizes capable of delivering up to 70,000 gallons per hour against a head of 300 feet or so; for depths beyond this it is usual to suspend a portable sump and to use a second pump on a lower stage, or even a third pump, according to the depth of the excavation; in which case the connections for the pump used on the upper stages can be made comparatively permanent, it only being necessary to adjust the pipes for the pump in use at the lowest level. One important requirement of a sinking pump is that of being (if steam-actuated) dead certain to start from any position, and be proof against the racket caused by racing when drawing above the water line. Obviously a desideratum in a pump suspended down a dark shaft is that of being very strongly made, and of having no unprotected mechanism, it being a class of pump probably exposed to the roughest usage imaginable, what with the loose method generally employed for fixing things up for operation, the liability of condensed water gaining access to the steam cylinder, and the suction pipe not being completely immersed. The Denaby pump, *vide* Fig. 37, consists of three hollow plungers, the upper pair R being stationary. Over these are sliding barrels connected by rods to the steam piston; a third plunger G projects from the lower end of these barrels V; this plunger works in a third barrel B, and is actuated, together with the first two barrels, by the steam piston. The third barrel is secured together with the pair of stationary plungers R to the steam cylinder E by means of connecting-rods; thus it will be seen there are two small barrels V in connection with the large ram G moving between the smaller rams R and the large barrel B, which are also connected together.

There is a series of india-rubber disc valves D in the junction between the smaller barrels and the large ram which constitute the delivery valves; and another series of valves S at the bottom of the large barrel constituting the suction valves.

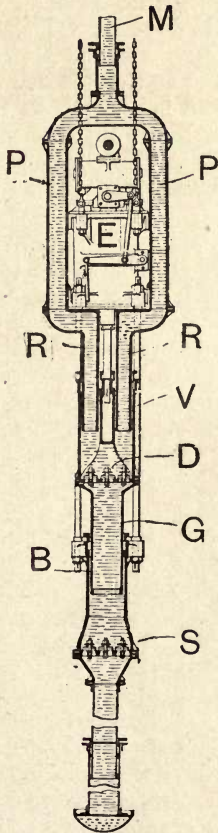

Fig. 37.—Denaby Sinking Pump.

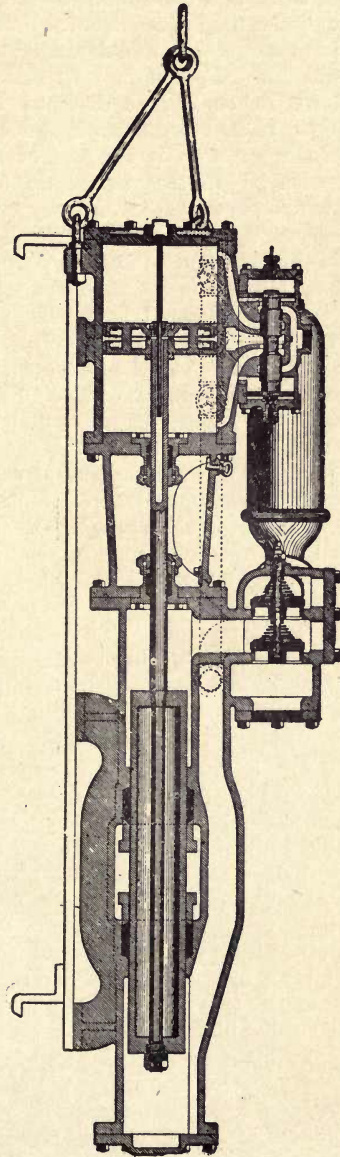

Fig. 38.—Marsh Sinking Pump.

The action of the Denaby pump is as follows:—As the plunger rises water follows it into the lower barrel B and at the same time the water in the hollow

plungers R is forced into the rising main P M. On the down stroke the water in the lower barrel B is forced through the lower plunger G and valves D into the upper barrels V and plungers R, and thence into the rising main; thus it will be seen, there is a continuous delivery on both the up and down strokes. The steam cylinder used is constructed on the same principle as for the Davidson simplex general purposes pump, described in Chapter XI., *vide* Fig. 96. In regard to the general dimensions, it may be stated that a 50,000 gallons per hour size pump is fitted with a 22-inch diameter by 27-inch stroke steam cylinder; a suction plunger 18 inches diameter, and two delivery plungers, each $8\frac{3}{4}$ inches diameter. Such a pump is capable of delivering this quantity at 35 strokes per minute with 80 lbs. steam pressure, and against a water head of 300 feet, which rate can be accelerated on emergency some 25 per cent. In this pump there will be seen a strong family likeness in the principle of the method of its operation to the ram and plunger type of pump, inasmuch as the area of the bottom hollow plunger is equal to twice the combined areas of the two upper fixed plungers; the bottom hollow ram, together with its series of delivery valves, corresponding to the bucket plunger and double-beat valve, and the two upper fixed plungers to the ram displacement plunger, as shown in Fig. 34, which it closely resembles, also in being double-acting at the delivery end and single-acting at the suction end. It may be remarked in parenthesis that this form of sinking pump has the advantage of being not only double-acting, but is more accessible than would appear at first sight, the three plungers being each outside packed, while both sets of multiple valves are easily got at through side doors not shown in the illustration.

A typical example of American sinking pump practice is shown by the sectional view, Fig. 38, representing a Marsh pump. In this pump there is a simple double-acting ram plunger, the barrel being cast in one piece and bolted direct to the steam cylinder. The water valves for both suction and delivery are arranged one over the other in a box situated at the front side of the pump immediately under the steam-distributing valve chest, a water portway being cast in the pump barrel communicating with the bottom plunger ram. The action of the steam valve calls for some description, it being entirely independent of actuating gear:—The distribution of steam is obtained by a double piston valve, which controls ports communicating with the two ends of the cylinder in the ordinary way; this valve is provided at either end with an actuating piston of about twice its diameter; the inner sides of these two pistons are placed in communication with the cylinder portways by means of passages controlled by small regulating plugs, the outer ends being provided with separate small port passages of their own, which communicate direct with the cylinder, and at a distance from either end equal to half the thickness of the main piston, which is made in halves with an annular space between. In order to admit steam between the two halves of the main piston at the required pressure for actuating the valve pistons, a small pipe is fixed to the outer cover which telescopes into the main piston-rod through a packed gland, and by this means the steam necessary for traversing the distributing valve is obtained, the main piston serving as a slide valve for the two valve pistons, which receive a positive movement in both directions without outside actuating gear of any sort. Another sinking pump of very similar construction, but fitted with a steam cylinder arranged with the Blake steam-thrown valve is made in sizes from $3\frac{1}{2}$ to 12 inches diameter of plunger, and with steam cylinders from 7 to 18 inches diameter, and are capable of delivering from 3,000 to 300,000 gallons per hour at a plunger speed of 100 feet per minute. In the Blake sinking pumps, as in the Marsh

speciality, there are no outside moving parts, the construction being adapted to withstand the rough usage to which all sinking pumps are exposed—*i.e.*, in being slung for continual change of working position.

A sinking pump of quite another pattern is shown at Fig. 39, this being a modification of the Ashley pump above described. For this purpose the pump is provided with a telescopic suction slide arranged to be regulated from the surface.

This pump is adapted for being actuated either direct from an engine or from a geared crank shaft at the surface, and can afterwards be conveniently used as a service pump if required. In this pump the connecting-rods for the plunger and the suction slide, together with the delivery pipe are built up in sections as the sinking operation progresses, intermediate stages being conveniently provided for by the sliding suction pipe.

An example of an electrically-driven centrifugal turbine sinking pump is illustrated by Fig. 40. This class of sinking pump is capable of

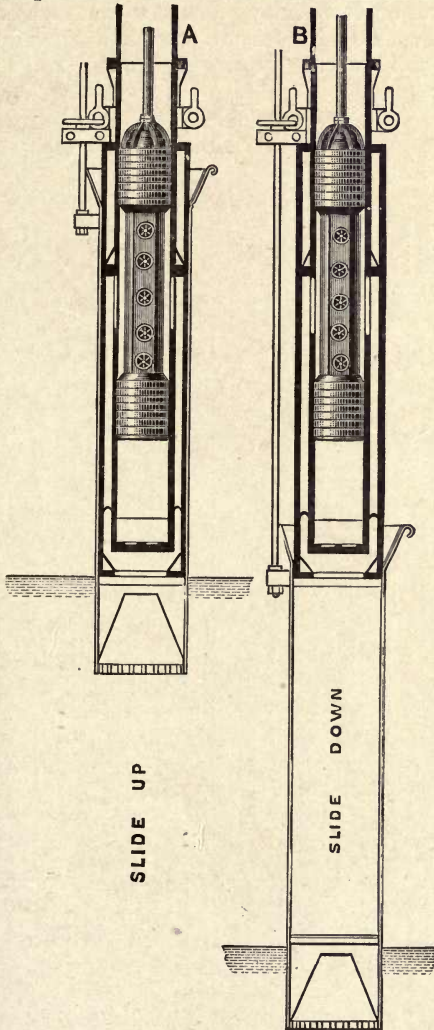

Fig. 39.—Ashley Sinking Pump

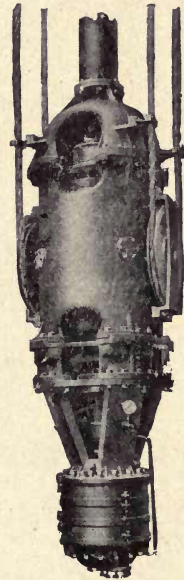

Fig. 40.—Electrically-driven Turbine Sinking Pump.

delivering against a head of 600 feet. A special feature in this pump is the method of cooling the electric motor by passing the water delivered by the pump up through an annular space provided in the motor casing; this method of cooling is found not only to be quite as efficient as by air ventilation, but is, in addition,

safer for mining work, as it enables the motor to be totally enclosed, so protecting the electrical portion of the machine from damp or mechanical injury. On each side of the motor casing are provided heavy steel pulleys, from which the pump and motor are hung in the shaft by steel ropes; the delivery column is in turn carried by the special form of breeches pipe shown above the motor, so that as in the case of a large pump the total weight can be supported in this manner, which, including the full column of water, may amount to as much as 40 or 50 tons. On this account it is, of course, necessary to provide a powerful winch or apparatus at bank for raising and lowering the sinking pump; and so

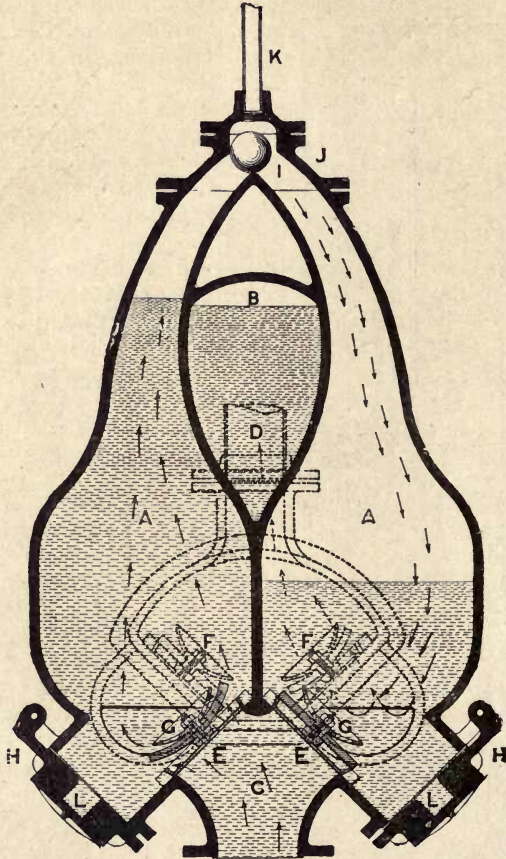

Fig. 41.—Pulsometer Sinking Pump.

as to obtain the greatest possible stability of the apparatus it is usual to fix steel clamps at frequent intervals on the column to serve as guides for the steel ropes.

A totally different variety of sinking-pump is to be found in the pulsator class of pumps, these constituting an extremely useful and cheap appliance for any temporary purpose, and are peculiarly adapted for the drainage of excavations, wells, and the like, during sinking operations. This form of pump, although not claiming as a strong point a very high economy, is, on the other hand, the most easily set to work, and moreover requires absolutely no provision

for attachment to the wall of the shaft as in other pumps, it sufficing merely to suspend the apparatus by means of a chain or rope running over a pulley block to the required level, when the water delivery pipe can be at once connected up to the surface, a flexible metallic pipe being conveniently used for the steam supply; there is, moreover, no occasion for an exhaust pipe.

Pulsator pumps are, however, limited as to the practical water head or height of delivery to within 100 feet, including suction, the most efficient results being obtained on a steam pressure of from 45 to 60 lbs. per square inch, and a water head from 15 to 60 feet or so, although it is common practice to test pulsator pumps up to a head of 90 to 100 feet. Obviously, with the higher pressures, a greater degree of condensation occurs, this class of pump, from its very nature, exposing the steam to a maximum of condensing surface.

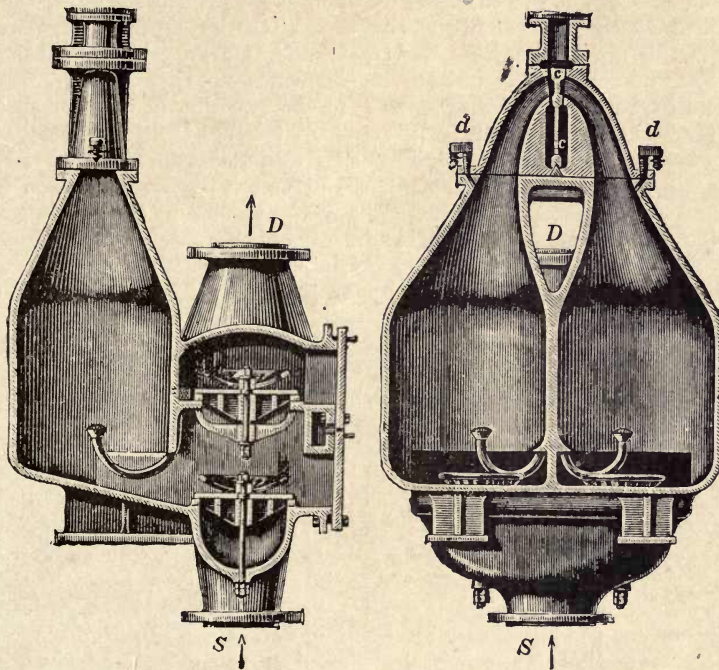

Fig. 42.—Sectional Views of Korting Pulsator Sinking Pump.

Pulsator pumps consist essentially of two cast-iron chambers of a pear-shaped form, and cast in one piece side by side; these are provided at the junctions of the two stems of the pear-shaped chambers with an oscillating steam valve or clapper, which is common to both sides, its action serving to open and close each mouth alternately, with the result that while steam is passing into one chamber the mouth of the other is closed. At the lower part of each chamber is arranged a suction valve, which separates it from the inlet opening, the chambers also branching off to a delivery valve leading to the delivery pipe. The action of a pulsator is as follows:—On referring to the sectional cuts, Figs. 41 and 42, which represent typical examples of present practice, and supposing either of these pumps to be primed and ready for starting—*i.e.*, having the chambers filled with water (for this class of pump will not generally start without this

being done if required to draw from a level much below the inlet)—now, on opening the valve, steam will enter at the apex K of the two chambers A A ; it will then pass either the ball valve I or clapper C, situated in the neck lying between the two throats, the action of the oscillating valve being to close one throat and open the other for the entrance of steam, which then presses upon the surface of the water, without, however, in any way ruffling it ; the steam thus forces the water gradually out through the back-pressure valve indicated at F, Fig. 41, into the delivery pipe D. When now the water has been depressed as far as the lower edge of the chamber, the surface becomes agitated, and the rate of condensation consequently increased, besides which a certain amount of steam escapes under the dividing wall between the delivery valve chamber and the two filling chambers A A ; this results in a sudden decrease of pressure in the chamber, to which steam is being supplied, and has the effect of drawing over the ball valve or oscillating clapper, as the case may be, and in this manner shutting off the steam. Immediately this takes place, the chamber just emptied condenses the steam now occupying the place of the water, which process may be expedited by the injection of a water spray by rose pipes, as shown in Fig. 42. The resultant vacuum then causes this side to fill with water from the suction pipe at S or C ; during this operation, the opposite chamber will be in turn emptied as before by steam pressure admitted by the oscillating valve controlling the entrances to the throats in the dividing necks. This action goes on repeatedly, each chamber being alternately filled and emptied in turn. In addition to the injection of water after each chamber is emptied, there is a further economy gained by air-sniffing valves situated in either throat, which serve the purpose in partially insulating or dividing the steam from the surface of the water to reduce the rate of condensation, and thus compensate for an extravagant consumption of steam.

Another method adopted for conducing to more economical working in the make known as the Pulsometer pump (the progenitor of this class) is to obtain an automatic cut-off by means of a cup valve situated in a chamber immediately above the oscillating ball valve I. This cup floats in a cylindrical seat, communication to the space underneath being adjusted by a small by-pass controlled by a small set-screw ; the action of this cup (termed the Grel valve) is to rise and close the mouth of the steam inlet on a slight reduction of pressure, which occurs after a degree of momentum has been imparted to the water, thus accelerating the inflow of steam, there then results a slight difference of pressure on the two sides of the cup. Pulsometer sinking pumps are made in various sizes to lift from 1,000 to 150,000 gallons per hour, the output being based on a lift of 20 feet. The quantity discharged diminishes by about 25 per cent. on the lift being increased to 70 feet or so, and for all practical purposes the height of lift is limited to a total head not exceeding 100 feet on a steam pressure of 65 lbs. when worked in single stage.

In an improved form of Pulsometer pump having chambers of considerably less capacity than usual, a construction that is compensated by an increased flow of injection water, a less degree of condensation is realised and higher economy obtained. In consequence also of its quicker action, this pump is suitable for steam pressures up to 100 lbs. per square inch, and water lifts up to 170 feet, the quantity of water capable of being discharged being about double on the total head being reduced to one-third and *vice versa*. In point of steam consumption, tests with pumps made by the Pulsometer Company show that less steam is required per water horse-power on 150 feet than on 90 feet total head, also that these pumps will start without priming on a suction lift not exceeding 16 to 18 feet.

CHAPTER VII.

SUCTION AND DELIVERY VALVES.

In connection with the working of large pumping engines, it cannot be said that there appears to be any very decided advantage in the use of one form of valve over another. For instance, under identically similar circumstances ring double-seated valves, such as shown by Fig. 43, are used side by side with the beehive arrangement of multiple valves shown by Fig. 44, these two forms of valves having an almost equal advantage in area of waterway, and are both adapted for either a suction or foot valve, or delivery or bucket valve. Referring to Fig. 43, the valve *V* (usually cast in gun-metal) is formed with two rings, each having two seats which rest—one on a seat on the outer ring of the seating

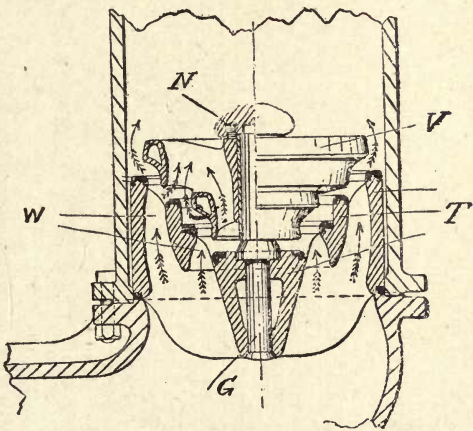

Fig. 43.—Quadruple-seated Suction Ring Valve.

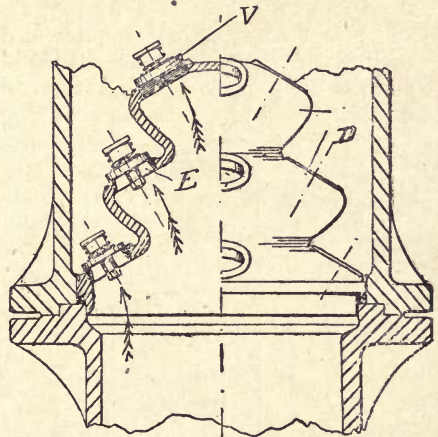

Fig. 44.—Triple Tier Beehive Multiple Valve Box.

T, two on the second ring, and one on a seat around the hub carrying the guide stem *G*; the seating *T* is in cast iron, and faced with gun-metal rings. In the illustration the valve is shown open to its fullest extent, and affords four ways *W* for the waterflow, as indicated by the arrows; water can thus flow past four seats, although there are only two annular openings *W* in the seatings *T*, and it will be clearly understood that an area of waterway more than equal to the area of the ports *W* is easily obtained without excessive lift, which in this case is shown to be limited by a buffer stop *N*. Valves of this type are sometimes made as shown in Fig. 34 *ante*, having only one ring, and thus present three openings for waterflow past the seats, which in that case must pass partly through a series of port openings between the ribs of the valve, and partly round the outer edge, the seating forming a part of the suction pipe, and is, except in this

respect, similar to Fig. 43. Ring valves are found to work very satisfactorily in direct-acting pumping engines, having a pause at the end of each stroke, and in rotative engines not exceeding 10 to 15 revolutions or so per minute; but when forced much beyond this limit they are prone to close on their seats with a thumping action not experienced to so great an extent with valves of the multiple class, as shown by Figs. 44 to 47. When fitted in a beehive form of valve box they are usually arranged in two or three tiers, around which are either fitted lift valves of from 2 to 4½ inches diameter, or a suitable form of flat valve. In the illustration, rubber or vulcanite valves V are shown, these being held down to gun-metal seating rings E, screwed into the ledges D of the valve box by springs; similarly also, gun-metal mitre-seated valves can be used. On the question of area of waterway obtainable, there is little to choose, as, when fitted in a plunger bucket, the ring double-seated valve will give from 35 to 45 per cent. the area of the plunger, according to the available area of opening between the seats, and multiple valves rather less than this, but depend, of course, on the number of tiers used.

Another form of multiple valve is the "flapper," illustrated by Fig. 45, which is a construction of valve and seating that affords good results in pumps used for low lifts, and one particularly appropriate for obtaining

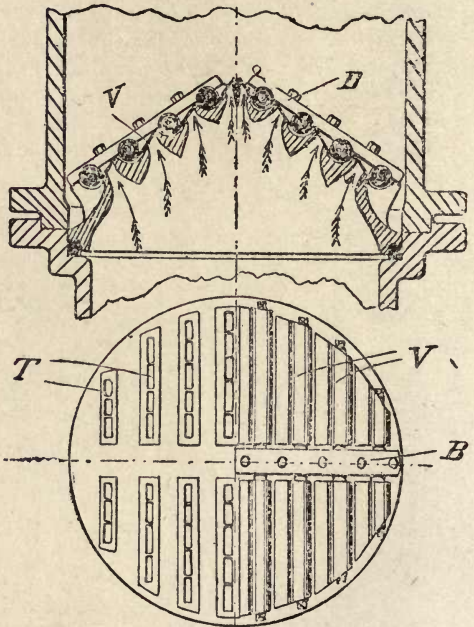

Fig. 46.—Arrangement of Spring-seated Copper Flap Gutermuth Valves.

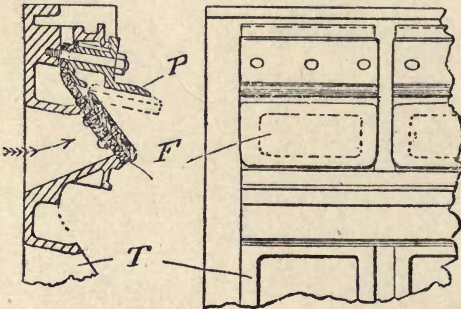

Fig. 45.—Arrangement of Metal-backed Rubber Flap Valves for Suction or Delivery.

a very large waterway. The valve F is formed of a specially prepared rubber, backed with a composition having a lead inset for the purpose of holding it down to its seat T, which is arranged at an angle of 45°; a stop-plate P is used to limit the lift with no spring, thus affording a very free opening. A similar class of valve is shown at Fig. 46, constructed out of thin hard copper sheeting of a gauge to suit the pressure, and is formed to fit over rectangular grid openings T; one end of the flapper is coiled to form a spring, and is threaded on to a spindle, having a groove engaging with the inner edge of the coil. These valves are usually carried in pairs, one at each end of the spindles, which are gripped by a bearing cap B, thus permitting an easy adjustment of the coil tension by means of a key fitting the squared ends of the spindles; in this manner the flappers V can be tuned, as it were, to give the best results. The illustration shows a form of valve

box adapted as a suction valve of a large pump, and can be lifted bodily out of the pump barrel or casing as in the case of Figs. 44 and 45.

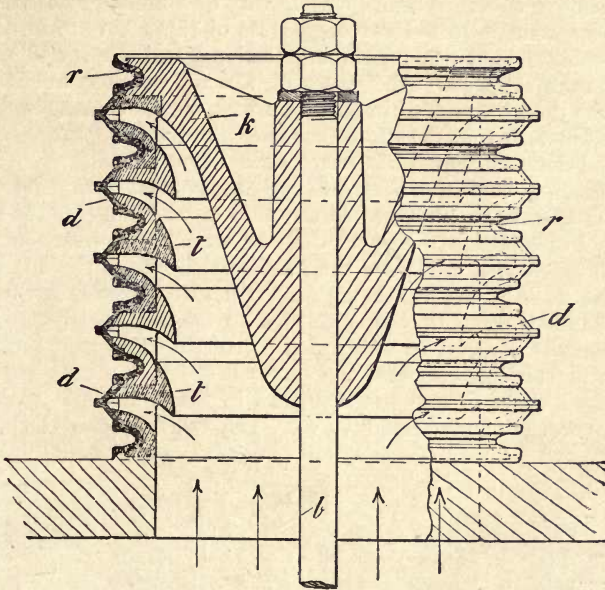

Fig. 47.—Witting Multiple Gill Suction or Delivery Valve.

The sectional valve shown at Fig. 48 was designed as an improvement on the single-seat type of valve for the purpose of reducing "thud" associated with high speeds; this valve is multiple and of a pyramidal formation, having an ordinary disc V, which fits over one or more wheel-shaped valves D, the rim

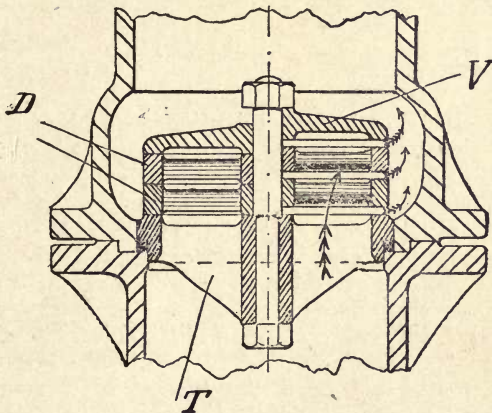

Fig. 48.—Half-sections, showing Multiple Disc Flat-seated Valves, Open and Closed.

edges of which when closed, as shown in the half-section form a water-tight fit to one another and to the seating T, the disc V closing over the rims D, which

in their turn close on to the seating T. When open for the waterflow, as, for instance, produced by the suction of a pump, the several sections of the valve separate as shown, and thus afford a waterway of a much greater area than can be obtained by a single-seated valve. Valves of this form are in use at several of the Metropolitan and other pumping stations, and are found to work very smoothly at normal speeds; the vanes of the rim sections are inclined about 5° to serve the dual purpose of imparting a whirling movement and of opposing a slight resistance to the waterflow to insure the requisite lift. Earlier forms of suction and delivery valves of the pyramidal type are shown by Figs. 49 and 50:—Here in each case the complete valve separates into three sections on opening, thus affording about double the area of waterway of the single-seated valve of equal diameter. In Fig. 49 the ring sections are mitre-seated, and are bored out to serve as a guide for the next section above them; each section, as well as the clack at the top, being provided with vanes. In this form, however, the pyramidal principle was not found to work as anticipated, there being too great an area opposed to the waterflow on the two ring sections, and in consequence of this, on opening, the water instead of raising each section as shown, lifted all more or less together, and in action resulted with little or no advantage over the single-seated valve. The triple-hinged clack, Fig. 50, is

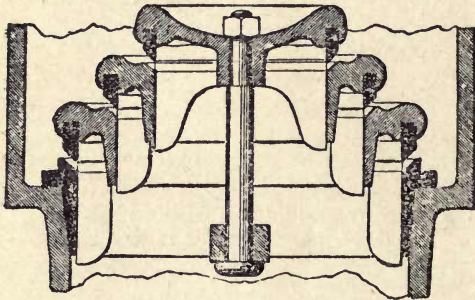

Fig. 49.—Pyramidal Arrangement of Mitre seated Valves.

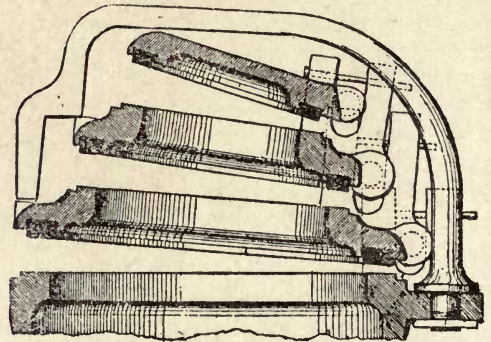

Fig. 50.—Pyramidal Arrangement of Rubber-faced Hinged Valves.

shown faced with rubber, each clack being independently controlled; thus the fault of all lifting together is prevented in this case; this form of multiple lift valve appears also to have been carefully designed, and to present some advantages, although it has long gone into disuse, possibly owing to the expense and complication of the fittings. The valve shown at Fig. 51, although constructed in sections and in pyramidal form, is an ordinary "gill" valve fitted with rubber rings, held in place by the several sections, which are in turn held down by bolts as shown; this valve affords a greater area of waterway for its diameter than any other valve, even when allowing for the obstruction of the numerous bars across the annular waterways.

Mechanically-actuated valves of the Riedler type, *vide* Fig. 206, have been used with some success in pumps of large size, but where the conditions of working impose a varying speed and water head the timing of these valves does not always synchronise harmoniously with the pump plunger and water column, such valves having in some cases been modified on this account to work automatically; there are, of course, other considerations to be taken into account

in a pump fitted with "timed" valves, such as provision for holding the water back when forcing against a head and for retaining water in the suction pipe at starting.

Probably the earliest form of suction and delivery valves were simple leather flaps, similar in form and arrangement to that used on present-day manual lift pumps; in the earlier makes of steam-driven mine pumps, hinged metallic valves faced with leather were used in the bucket plungers and for the suction inlet or foot valve, these being arranged back to back very much as shown in Fig. 52; which form of flap or butterfly valve was usually hinged on a brass seat provided with a guide stop to limit the opening. In a more modern application of the flap valve for drainage pumps, rubber composition flaps backed with lead are used, the flaps being arranged at an angle of 45°, over cover grid

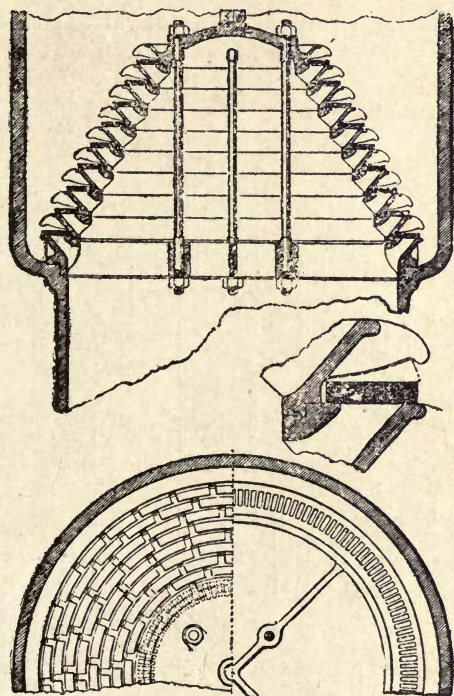

Fig. 51.—Pyramidal Arrangement of Rubber Ring or Gill Valves in Multiple Series.

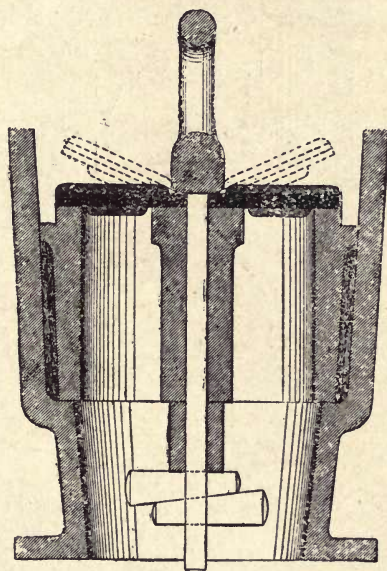

Fig. 52.—Butterfly Leather Flap Foot Valve.

seats in size from 2 to 4 inches wide by from 6 to 20 inches long, in manner shown in Fig. 45, and is a form of valve that lends itself for an exceptionally liberal waterway. The valve illustrated by Fig. 46 is another development of the flap valve, the flaps being formed of thin sheet copper, specially hardened and coiled at one end to form a spring hinge; valves of this type are known as "Gutermuth" flaps, and are arranged in group formation on removable plugs for specially high-speed plunger pumps as shown; this form of hinged flap valve is also adapted for bucket plungers, in which when arranged in pyramidal form they afford a larger area with a limited lift than any other valve; another advantage claimed is reduced water slip owing to their quick action. Another early form of

valve is the mushroom, known also as a stem valve when provided with a central guide rod, and as a stalk valve when cast with vane guides, as illustrated by Fig. 53; valves of this type are usually made in brass with mitre and flat seats, the stalk vanes being usually set at an angle to impart a slight twisting movement, and—being limited to a diameter of 6 inches or so (more usually to a less size), and to a lift from $\frac{1}{4}$ to $\frac{1}{2}$ inch—require in consequence to be in great number, in order to afford a waterway sufficient for modern practice.

The valve shown in Fig. 54 is an early form of multiple seat lift valve, variously known as multiple-beat, ring, crown, etc., and was first introduced to comply with the requirements of the Cornish pumping engines, in order to obtain the requisite strength and waterway capacity unobtainable with a single-beat valve; the quadruple-seated suction ring valve shown in Fig. 43 is the latest development of this type.

There have been various gill, band, and other flexible forms of valves intro-

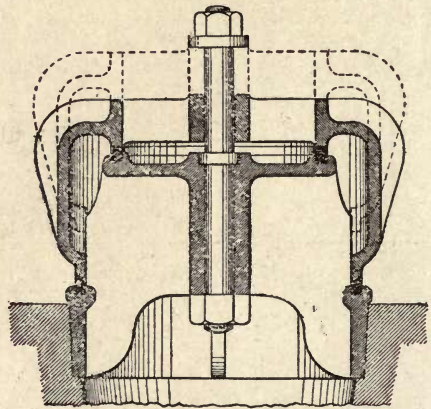
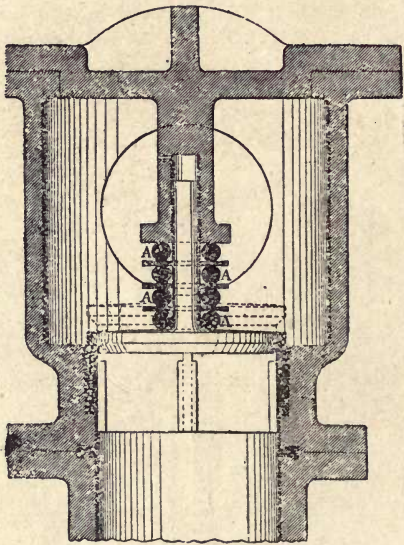

Fig. 53.—Common Form of Single Mitre Valve.

Fig. 54.—Double-seated Ring Valve.

duced from time to time, as the outcome of the desire to obtain an increased waterway capacity, smoother action, and greater freedom from water hammer. The gill valve, as shown in Fig. 51, consisting of a number of ring seats with rubber rings can be made to easily afford a waterway of greater capacity than the area of the valve base, but as in the case of band valves, consisting of a series of hat-shaped seats covered by elastic bands, have not been used to a great extent, owing to the expense of valve renewals, and to the high pressures now worked at. However, this type of valve has recently been much improved, and in its latest form (known as the "Witting" valve), owing to the smoothness of its action, has many compensating advantages for all high-speed pumps worked at pressures not exceeding present-day waterworks practice. The "Witting" valve, which is made in pyramidal form (as shown in Fig. 47), consists of a series of sectional metallic rings (*t*), one fitting within another, and to a height equal to about the diameter, which are held down

by a central bolt (*b*) and cap (*k*) to the pump body. The rings (*t*) are each provided with circumferential openings (*p*) separated by ribs, which openings are each normally closed against water return by a pair of metallic disc flaps (*d*), these, in addition to being held together by water pressure, are pressed together by a series of rubber bands (*r*) sprung into grooves around the sections (*t*). In action the parting of the discs (*d*) to permit the outflow of water is with five discs as shown, less than one-fifth that necessary with a single-beat valve, as the discs are somewhat larger in diameter than the base of the valve. The direction of waterflow is less subject to abrupt change than in the ordinary multiple-seated ring valve, and, moreover, as the discs are comparatively light, they oppose little resistance to movement and are quick in closing, both advantages equally shared with the spring coil flap valve above described. The flexible disc form of valve, such as shown in Fig. 55, first introduced as an ordinary water-pump valve, is now only used in condenser exhausting pumps, this form of valve with discs sufficiently flexible to allow a free way for the water, not being strong enough for the pressures used in waterworks' engines, even when provided with a grid seat, in which respect they compare with valves of the metallic disc or Kinghorn type, in being limited to comparatively low pressures. The form of valve for almost every kind of pump work now mostly used is what may be said to be a development of the flexible rubber disc valve just described, and as may be gathered by the illustration, Fig. 56,

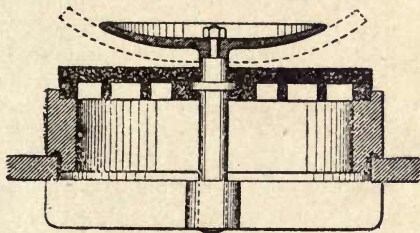

Fig. 55.—Grid or Diaphragm Valve.

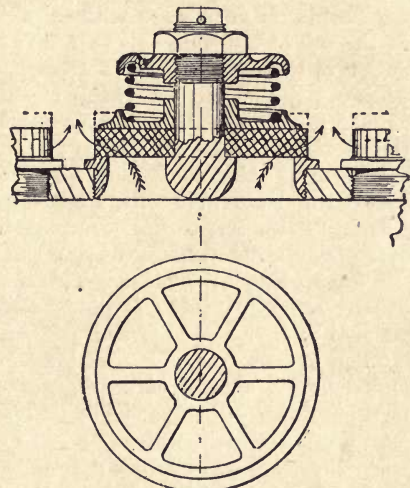

Fig. 56.—Modern Form of Suction or Delivery Composite Disc Valve, arranged in Multiple Series.

closely resembles it. This universally used form of valve, however, differs in an important detail—viz., in being faced with hard rubber or composition, and in being held up to its work by a spring—a construction that, provided the diameter of the valve does not exceed 5 or 6 inches, and that it is used in sufficient number to limit the lift to $\frac{3}{8}$ inch or so, renders this comparatively simple form of valve as silent in action and durable as any other.

The type of valve that has continued in favour for the longest time for use under ordinary pressure conditions met with in mining or water-supply engines, working with a slow beat, is undoubtedly some modification of the double-seated ring valve. Multiple-lift valves, however, on account of their limited "lift," are better suited and work with a smoother action at the speeds obtaining in the more modern pumping engines of the rotative class than the larger double-seated valves with their greatly increased lift. For example, a

quadruple-seated valve of 25 inches diameter is allowed a maximum lift of nearly $1\frac{3}{4}$ inches when its opening exceeds the area of waterway in its seating, the width of the annular portways being in this instance $2\frac{1}{2}$ inches, and total area of waterway 270 square inches, and the inside diameter of the three outer seats 24, 17, and $13\frac{1}{2}$ inches respectively. A valve of these dimensions works well in a pump with a plunger of 19 inches diameter by a stroke of 7 feet, and running at a maximum of 12 beats per minute. Again, in another pump, fitted with a beehive arrangement of "woodite" valves, 2 inches diameter by $\frac{3}{8}$ inch lift, a total of 120 valves are required to obtain the same waterway, the plunger speed being approximately the same in each case—*i.e.*, 140 feet per minute—but with this important difference, that this pump works with a beat of nearly 25 per minute, thus proving that the peculiarities of the two valve arrangements had been duly considered in designing these two engines. The suitability of the high-lift valve is even more pronounced in such cases as the Davey compound-beam engine, illustrated by Fig. 8, and other non-rotating engines provided with a pausing gear, so allowing ample time for the valves to settle properly on their seats after each stroke; but for rotative, duplex, and other pumping engines designed to work with a quicker beat there is an undoubted advantage in the use of multiple valves in one form or another, and to further soften the action of these engines the valves are for the most part either made of specially prepared rubber with a metallic backing, or, if in metal, are provided with a rubber facing, and in modern American practice is the form of valve finding the most favour for all classes of rotative and duplex pumping engines, where this form of valve consists of a rubber disc, which is supported by a brass disc grooved and provided with a bearing boss, the rubber disc being usually about 4 inches diameter, the size varying from 3 to $4\frac{1}{2}$ inches, and rests on a brass seat with six radial bars carrying the guide stem; on this is screwed a grooved cap for holding down a brass-wire spring to the required tension; the seats are usually screwed into valve plates in groups of from 10 to 30 valves, which are covered by a grid or cage, as a safeguard against a valve breaking loose. A great number of these valves are used as many as 500 being provided for both suction and delivery, a total of nearly 1,200 valves of 4 inches diameter being fitted in a pump having three single-acting plungers 34 inches diameter, this number affording an area of waterway of 130 per cent. the area of the plungers, which work at nearly 200 feet per minute.

The form of pump used also varies considerably in different engines, and confining our purview for the present to such as are employed in pumping stations and the like, we find the bucket and plunger pump used in engines of the slow running rotative beam type; double-acting piston plunger pumps in two and three-crank direct-acting engines of large size; single-acting ram plunger pumps in three-crank engines; especially is this the case in American practice, where the vertical rotatory type of engine is principally used, being made in this form up to 60 inches diameter and 10 feet stroke. In the duplex class we find the double-acting piston plunger, while for deep-level pumping engines of the horizontal geared and differential direct-acting simplex type, bucket and ram plunger pumps are used. Generally speaking, ram or outside packed plunger pumps have an advantage for the higher pressures, and are for this reason always used for hydraulic work, but for purposes where the conditions of engine design and water head will permit there is considerable advantage in employing a type of pump having a double-acting piston plunger, owing to the more uniform water-flow obtained, and to decreased friction.

Other considerations are found to influence the form of pump used in engines

of the rotative type, such as number of cranks and length of stroke, single-acting ram plunger pumps being generally used for all classes of three-crank engines; there are, of course, exceptions to this rule where an especially uniform flow is desired. The double-acting piston plunger pump is always found in combination with the two-crank engine when made in large sizes, in which case with cranks at 90° there is no other alternative than to make the pumps double-acting.

CHAPTER VIII.

BORING APPLIANCES FOR ARTESIAN TUBE WELLS.

TUBE wells afford a most expeditious and cheap means for obtaining water in almost any district, even when, as in many localities, there is little or no indication of a water supply existing under the surface. There are two kinds of tube wells, the Abyssinian and the Artesian, of which the first-named is by far the simplest, as it involves the use of so few appliances, and is, therefore, for this reason often employed in connection with military and other expeditions. The Abyssinian well consists essentially of a perforated pipe of from $1\frac{1}{4}$ to 4 inches diameter, which is provided with a pointed plug to enable the pipe to be driven into the ground; a simple well may comprise two or three lengths of piping only, which may be connected up direct to an ordinary hand-lift or force pump. Wells of this type were first used to provide water for the British army under Sir Robert Napier during the Abyssinian War, hence the name given to such wells as can be formed by the simple process of driving perforated pipes into the ground to a depth sufficient for piercing a water-bearing stratum, the usual depth required being from 30 to 50 feet, although 150 feet has been reached in this way; driven tube wells of this class are mostly used where the subsoil is either gravel, coarse sand, or other loose strata of a porous nature, but are not suitable for clays, marls, or fine sands, and obviously are not capable of piercing hard sandstone, limestone or ground of a rocky formation.

The apparatus necessary for sinking one of these wells consists principally of a tripod and tackle, such as may be used for pile-driving, while a tube of the smaller size may sometimes be capable of being driven into loose sand strata to a depth of 30 or 40 feet by the skilful use of a beetle without any special appliance. A driving block is, however, preferable, and should be arranged so as to be guided in its fall to impart a correctly vertical impact to the tube, successive lengths being screwed on as required. Perforated tubes are sometimes driven into water-bearing strata at a distance of only a few yards apart, these being then connected up to a single suction pipe and pump for supplies which may attain to a capacity of from 10,000 to 40,000 gallons per hour; the usual capacity of a 2-inch well ranges from 300 to 900 gallons and of a 4-inch well from 1,000 to 3,000 gallons per hour, according to the depth and locality of the well.

For tube wells larger than 4 inches diameter, or deeper than 100 feet, holes have to be bored before driving in the tube; the principal interest, therefore, attaching to artesian wells is in the apparatus used for boring the holes; the name "artesian" well is a term derived from Artois, a French province where they were first extensively used; the action of artesian wells is due to the principle that water seeks to find its own level, hence the great number which are in use over the chalk of the London basin for supplying water to breweries, manufactories, steam-power stations, and the like; indeed, artesian wells are to be

found in towns in almost all parts of the world, and are now also being extensively used for irrigation purposes, although for the matter of that boreholes are used for other purposes than for forming wells for water supply—*e.g.*, (1) the numerous oil wells of Pennsylvania, South Russia, and other countries; (2) boreholes sunk in prospecting for minerals of all kinds, and for petroleum. The usual diameter of holes drilled for sampling or testing purposes is from 2 to 7 inches, according to depth and nature of material to be passed through, the test holes made in prospecting for coal in Kent and Sussex, for instance, by the Sub-Wealdon Exploration Syndicate, were 9 inches diameter for the first 300 feet or so, when the boring was continued a further 700 feet by a 3-inch diameter hole. In boring for oil, boreholes from 3 to 5 inches diameter are principally used, the upper strata being subsequently—or before completing the bore—tubed to prevent the sides falling in. Space forbids the treatment of this subject from a geological point of view, interesting as this may be, it sufficing to say, before going on to describe the various appliances used for boring for artesian wells, that in a borehole in the London basin about a dozen varieties of material have to be cut through before reaching the water-bearing chalk strata, commencing at from a 100 to a 300-foot level, while under Birmingham about 25 different layers are met with in boring a hole 500 feet down, these strata for the most part consisting of various kinds of sandstone. The subject is an exceedingly intricate and difficult one to compress into a few sentences so as to be generally intelligible and interesting, and, as in the case of oil-bearing strata, forms a subject quite apart from apparatus and pumps used in obtaining a water supply in this way. Just, however, to emphasise this statement it may be said that there are some 30 different formations, which may again be subdivided into about 100 different groups of strata to be met with in various parts of the world, endless combinations of which may be encountered in drilling down to the 2,000 ft. level, this depth being about the limit for all practical purposes, although exceeded in a few rare instances. Now, considering that rarely are two boreholes sunk under identical conditions, it will be admitted that great judgment and some considerable experience must be brought to bear in deciding as to the most suitable kind of boring apparatus to be employed in each separate case.

Boring appliances consist of several kinds, and each a variation of either the rotary or percussion type of machine, the former being used for drilling through hard rock and stone strata, and when it is required to extract cores showing the formation at each particular stage of the boring, while the latter are found to be quicker in action and otherwise more suitable for boreholes cut through soft sandstone, clay, marl, chalk, etc. For quite small holes of from 3 to 6 inches diameter, a hand-worked boring jumper can be used when the depth does not exceed 100 feet or so. This consists of a pole balanced horizontally on a trestle, one end being immediately over the point for drilling. Suspended at this end, then, is the drill, consisting of a steel bar flattened to form a cutting edge, and at the other end is a transversely arranged cross-bar or handle for the operators to lay hold of for the purpose of jumping the boring bar up and down after the fashion of using a hand-boring bar in drilling small holes in rock and quartz, etc., for blasting operations. A very useful adaptation of this method, constructed for being operated by steam power, is illustrated in Fig. 57, and affords a sufficiently clear idea of its working as not to require further description than the following:—This consists of an inverted steam hammer type of engine arranged under a larch pole, hinged at one end on a trestle, and carrying the boring tool at the other; by this means a quick, jumping action can be imparted to the drill until a depth of a foot or so has been cut through, when the drilling bar

is hauled up out of the hole and a sludge bucket lowered for bringing up the debris, or, as in some cases, the hole may be washed out by forcing down a stream of water by a donkey pump represented in the cut. The boring bar is suspended from a pulley carried by a tripod, the end of the rope being held by a pulley block and adjusting screw used for the purpose of holding the boring-bar suspended a foot or so from the bottom of the hole, according to the depth; by this means, on the steam piston being brought to rest by steam cushioning in the cylinder, the rope stretches and the bar makes a cut, the rope then recoils and aids the piston on its next up stroke. Attached to the tripod is a small

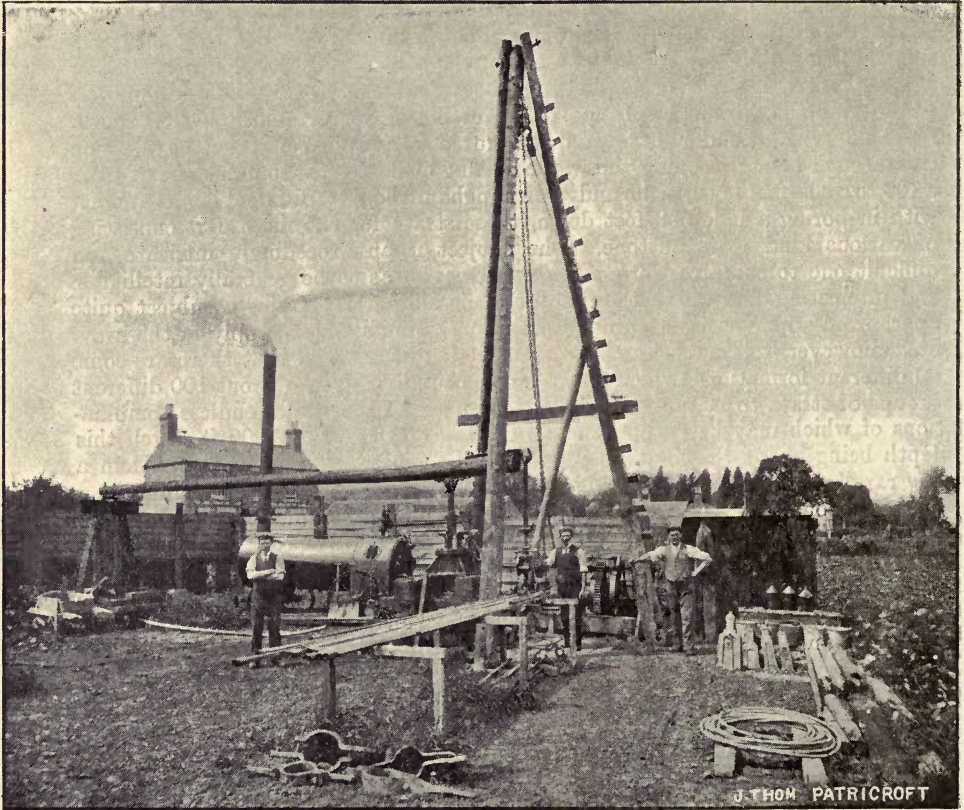

Fig. 57.—Steam Percussion Boring Rig, with Pole and Trestle Action.

winch for winding up the bar out of the hole, and it may be said that in connection with a boring plant of this kind may either be used a solid flat-headed boring bar or a hollow boring bar studded with carbonate, or carbonado, to give it its Brazilian name, this being a species of black diamond extremely hard, and at the same time without a tendency to split in certain directions. Artificial carborundum stones are also sometimes used for this purpose, and when the material to be cut through is not hard the hollow boring bar may be studded with hardened steel cutters; the hollow bar permits of the extraction of solid cores, as seen in the foreground of the illustration.

For boring larger and deeper holes a high derrick, as shown in Figs. 58 and 59, is used. This structure attains the height of about 50 to 70 feet in usual practice, this height being necessary to give the rope the necessary spring above the actuating beam, at one end of which the rope is gripped. In place of the jumping engine as described in the apparatus used for boring smaller holes, in this case a portable oil or steam engine may be used to drive a crank shaft by means

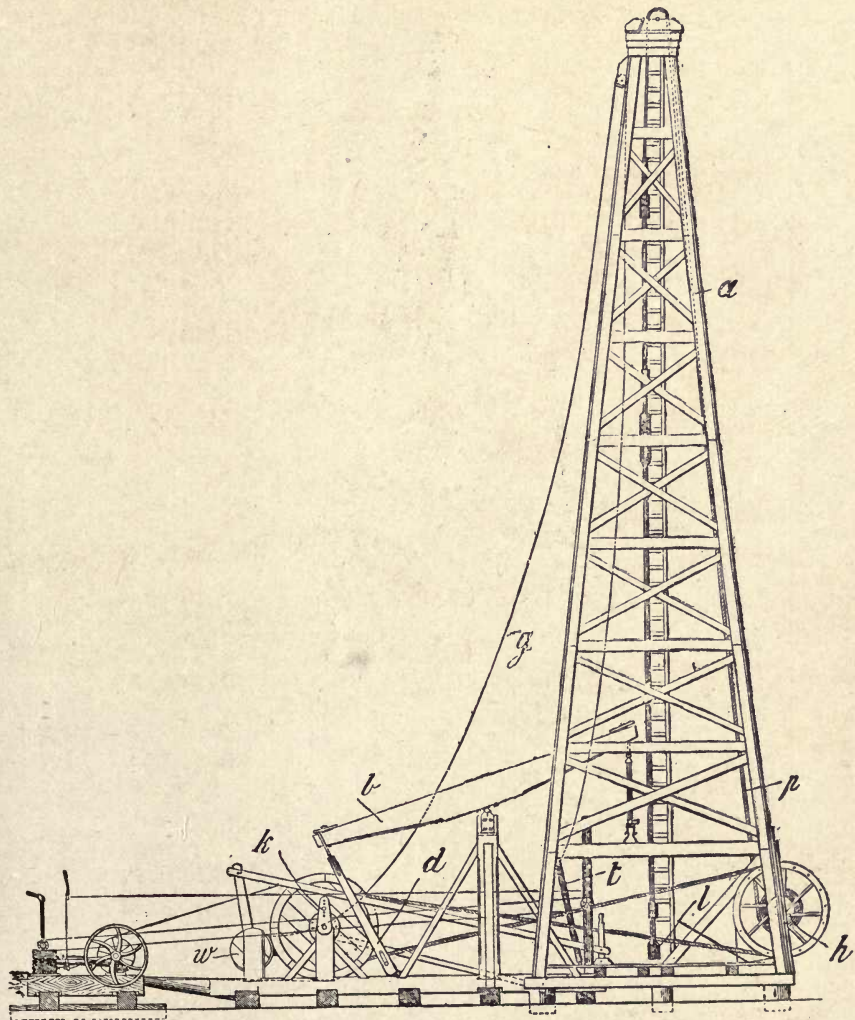

Fig. 58.—Elevation of Percussion Boring Rig, showing Action of Walking Beam.

of a large belt wheel, the belt being held taut or slack by a jockey pulley by the man in charge. A variable stroke is given to the beam (*b*) by means of a crank (*k*) having several holes along the web for the insertion of the driving pin at the required radius. The upper end of the rope (*p*) passes over the pulley on the top of the derrick (*a*), and then down on to the barrel of a winch (*h*), which

is held locked by a brake and let out as the boring proceeds. The derrick type of boring machine is used by several firms, and except in detail conforms to the general construction shown in the cut in all cases—*i.e.*, all use a high derrick.

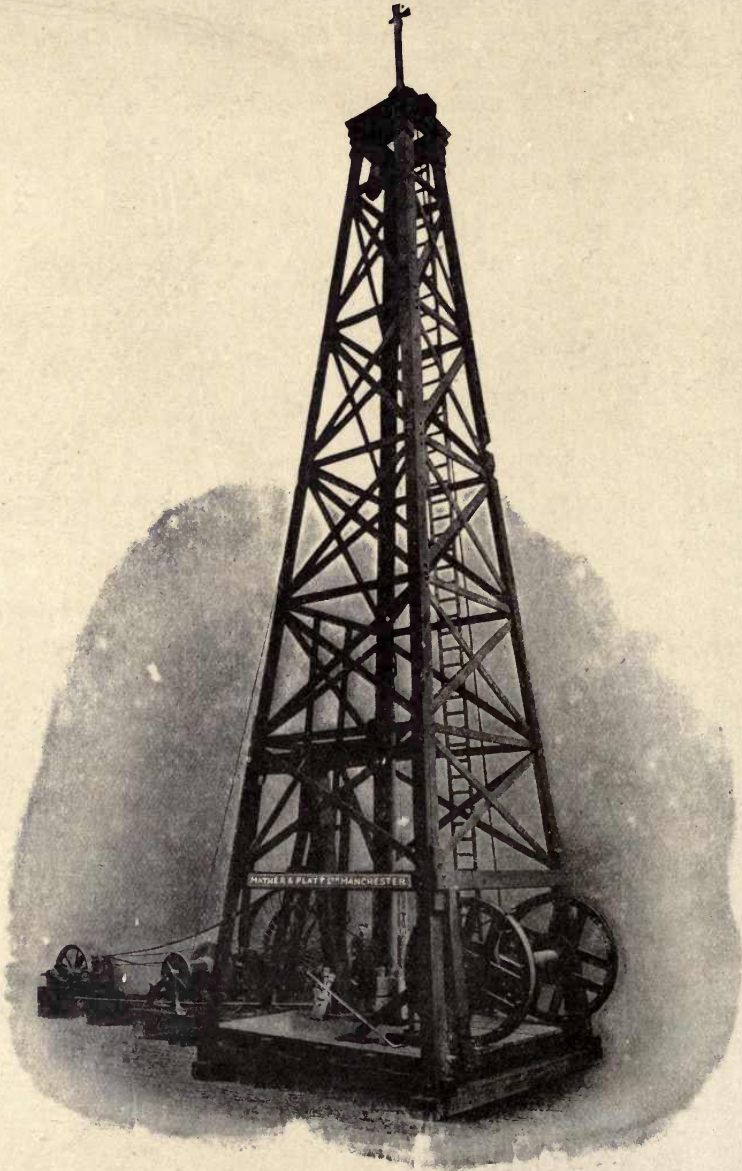

Fig. 59.—General View of Round Rope Well Boring Plant.

a swinging beam, jockey belt driving gear, etc. With this apparatus a much heavier bar (*l*) can be used, varying in length according to the diameter of the

hole, machines of this type being made for boring holes from 6 up to 18 inches diameter, and from 300 to 3,000 feet in depth. In all cases a round rope (*p*) is used, the bar being suspended by a stirrup, to which an oscillating movement can be imparted in a convenient manner by means of a handle attached to the rod just under the beam, this movement being effected without mechanism other than this by the operator, who swings the lever over first to one side and then to another, so causing the flattened cutting edge of the boring bar to cut all round the hole evenly.

In the action of a plant of this character, the bar is suspended some 3 feet or more from the bottom of the hole, and in work the bar in falling at each down stroke acquires sufficient momentum to stretch the rope across the gap thus intervening; the bar in springing back again by the recoil is caught by the upward movement of the beam and raised for another stroke, the speed being regulated to catch the bar at the right moment of its recoil, and results in a somewhat rhythmical action, which is continued until the bottom of the hole is choked with debris, when the bar is wound up by a special winch (*h*), forming a part of the plant and a sludge barrel (*t*), provided with an inlet valve in the bottom, lowered for clearing the hole by means of the rope (*g*) and winch drum (*w*), which is driven by frictional contact with the large belt pulley on the crank shaft. Boring apparatus of the derrick type is generally used for mixed strata of sandstone, clay, chalk, etc., and can be used for boring through hard rock.

Another type of boring apparatus widely used works with a flat rope, and was first introduced by Messrs. Mather & Platt, the *modus operandi* of this system may be described as follows:—Between the two front columns of the framework, which in this apparatus does not require much head room, there is arranged a steam jumping engine, which imparts a vertical movement to a pulley attached to the piston-rod crosshead working between guides in the usual manner. A flat rope is looped over this pulley, one end being attached to a coil held in a locked position by a brake drum, and can be let out as required for lowering the boring bar held in suspension from the other end of the rope. In this manner the bar is raised on the up stroke of the piston at twice the speed and stroke of the engine piston; owing to the looped method of attachment, the boring bar, which may be either hollow or solid, quickly falls by gravitation, and is as quickly raised again, the action being much faster than the beam and derrick boring apparatus. A rotary motion is imparted to the boring bar by an ingenious ratchet method, the point of attachment of the rope to the bar being made through a stirrup which hinges on a sleeve, which is free to slide between two collars on the stem of the bar. In action this sleeve is pulled against the upper collar on the up stroke, and falls against the lower collar in descending. Now, the sides and ends of the collars and sleeve are formed with ratchet teeth, the sleeve of which is arranged with one set of teeth half in advance of the other, and thus, in engaging first with one face and then with the other in an alternate manner, causes the boring bar to revolve one tooth at each double stroke, so maintaining an even cutting action around the hole. To clear out the sludge the bar is hoisted out of the hole by a winch and a sludge bucket, as seen to be suspended in front of the machine, is lowered for clearing the hole for further boring. The process of boring for an artesian well of large size—*i.e.*, anything from 18 to 33 inches diameter, and 1,000 feet and downward in depth—is a most tedious one, owing to the time occupied in removing the boring bar for clearing at frequent intervals, and to the necessity for tubing the upper strata before proceeding with the boring, all of which occupy much time, so that the operation of sinking and tubing such a well extends in many cases to

considerably over a year, the average time occupied in boring even to 500 feet being from 25 to 100 days.

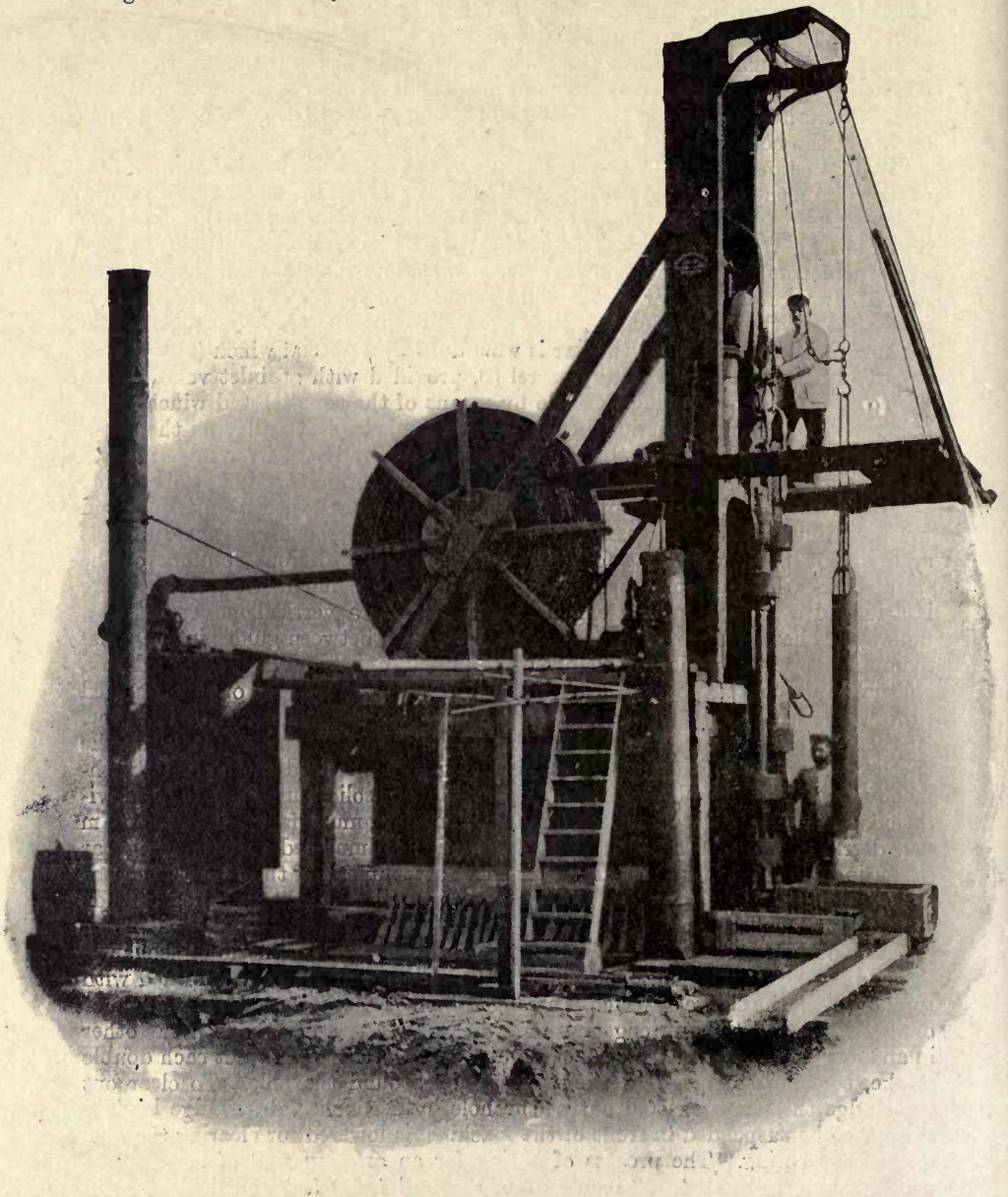

Fig. 60.—Flat Rope Boring Machine, showing Steam-driven Jumping Action.

In rotary boring machines there is no percussion action, the boring tube being balanced so as to bear on the substance being cut with a downward

pressure of from 50 to 100 lbs. per inch of diameter in the case of a drill having a diamond-studded crown; the regulation of the necessary pressure is under easy control, and can be readily varied to suit the particular hardness of rock under treatment. Boring bars may be either fitted with a short steel tubular crown, which is studded with carbonate, carbonado, or carborundum stones; or, as in some cases where softer strata intervenes between hard rock and limestone strata, a steel-studded crown-piece is used, by which means the softer material can be more quickly cut through. Then, again, there is yet another boring method, one having the advantage of great simplicity and employed in connection with a rotary boring machine. This consists of an iron tube of about $\frac{3}{8}$ inch in thickness, in which are cut a few V-shaped slots on the cutting edge, this simple form of boring bar being fed with water and small steel shot down a tubular driving shaft. The diamond rock-boring machine has, however, survived the test of long use, and is still employed with advantage where boreholes are required to be expeditiously sunk through exceptionally hard rock; such a boring bar equipped with stone cutters is capable of penetrating limestone at a rate of from 3 to 4 inches per minute, emery at 2 inches, quartz at 1 to $1\frac{1}{2}$ inches, and ordinary hard sandstone at 6 to 7 inches per minute when worked with a proper supply of water under pressure, and with the most suitable degree of pressure on the cutting edges. In forming a diamond-studded crown, a short steel tube is evenly faced and drilled with the number of holes on the cutting edge it is desired to fix in carbonate stones. Each hole is then chiselled out to the exact shape of the stone it is to receive, and when the stones are properly inserted, the metal around each stone is drawn by punches so as to almost cover the stones and the edge of the crown piece hollowed out between the stones to permit of a flow of water passing down the driving tube to escape under the cutting edge, and in this way wash away the debris as it is formed, and keep the drill cool. By this method it is not necessary to withdraw the drill at intervals for clearing out the hole; and, moreover, a perfectly round hole of the exact size required can be bored, and the inner core drawn up intact in such lengths as is convenient. More accurate balance is necessary to work a gem-studded boring bar with advantage than is the case when the drilling is performed by attrition of hard pieces of metal or stone supplied in a granular state with water.

An example of a rotary boring machine working on this principle is illustrated by Fig. 61, and represents the best practice in the use of the chilled shot method, which particular type of boring machine is constructed on the A. C. Potter system for boreholes ranging from 8 to 30 inches diameter, through any strata of hard chalk, rock, or stone formation. The boring tube may be either iron or steel, and is usually about $\frac{3}{8}$ inch in thickness; its upper end is closed by a solid cast-iron plug K screwed in by a square thread, the length of the boring tube being from 7 to 12 feet. In the centre of the plug is screwed the tubular driving shaft D, which serves the dual purpose of communicating motion to the boring tube and of carrying water down under the cutting edge in order to wash away the detritus as in the case of the gem-studded boring tube just described. The weight of the boring bar is partly supported by lifting tackle, from which it is suspended at the shackle S, and fed forward into its work according to the judgment of the man in charge, the adjustment of the cutting pressure not requiring to be so carefully handled as in the former case, where it is usual to balance the boring tube and driving shaft according to the depth of the hole by means of counterweights, the feed forward in that case being to a certain extent quite automatic in its action. The rotating gear in the example shown is very simple, and consists of a gear-driven ring V, from

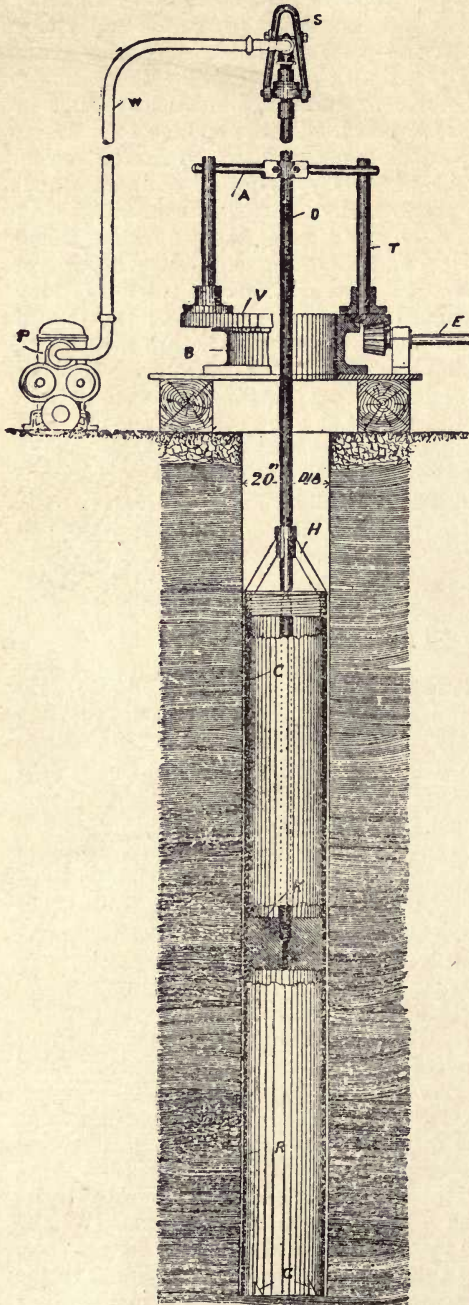

Fig. 61.—Rotary Abrasive-action Boring Machine.

which project two driving posts T, which are in contact with the ends of a cramp A bolted to the driving shaft D. The borehole, if the intervening strata be soft and show a tendency to cave in, may be quickly cased in by lowering a tube close up to the work. The cutting tube R is furnished with four notches G in its working face; their function, however, as in the case of the hollowed-out gem-studded crown in the diamond boring machine, is merely to afford a passage for the circulating water which is pumped down to carry away the detritus. The real work of cutting is performed by the abrasive action of chilled steel shot of about 2 to 3 millimetres in diameter, which is supplied together with the circulating water down the hollow driving shaft, and grinds a circular path underneath the edge of the boring tube; the shot, of which about half-a-pint is required for an 18-inch diameter hole per shift, rolls round in the groove under the boring tube by the rotation and pressure applied to the tube, and in this simple manner rapidly wears its way into the stone. As would be supposed, the boring edge is subject to wear, and requires squaring off after a few days' work, and from time to time the notches, therefore, have to be recut, and, of course, after a while the tube will wear too short for accurate boring, and will require to be substituted by another.

Above the boring tube R is carried a second tube C, called a chip-cup. This is open at the top, and guided by the head piece H, and serves as a collecting bucket for the sludge passing up between the wall of the hole being bored and the outside of the boring tube, and is emptied from time to time on the tube being hoisted up out of the borehole. It is,

however, by no means a *sine quâ non*, as the detritus or sudge can be washed up to the surface by the circulating water. There is another point in connection with this method of boring, and it will be of interest to know how the cores are removed when the cutter has gone down to the required depth to form a core of sufficient length. The machinery for this purpose is first stopped, and a certain amount of fine gravel put into the hollow driving shaft, which is carried down by the water and forms a grout, and thus binds the cutting tube firmly round the core; an upward pull is then given to the driving shaft, and at the same moment a powerful twist is applied which, together, have the effect of breaking off the core at its root. The core can then be pulled up along with the boring tube, and when landed a sharp tapping round the tube is all that is required to loosen the grout and enable the core to fall out. When boring a deep well, such as will be illustrated later in describing a direct-acting steam engine made by this firm for actuating a deep well pump, a high derrick forms a part of the boring equipment, which frequently attains to a height of from 50 to 70 feet, this, of course, being necessary in order to be able to hoist the boring tube and chip-cup clear of the boring machine, and for the convenience of screwing together one or two lengths of the driving tubular shafting D. The shackle S is suspended by a wire rope from a pulley at the top of the derrick, a steam hoisting winch being provided for raising and lowering this heavy mechanism from time to time as required, an operation demanding much care, for an accidental losing hold of the boring tube may result in weeks' loss of time. A portable steam engine for driving the boring ring shaft E and supplying steam to the duplex circulating pump P completes the plant necessary for boring a well on this system. It may be pointed out that the revolving ring V and bearing pedestal B permit of the boring tube passing up through them, the driving posts T and cramp A being then removed.

A boring tube working with chilled shot on the cutting edge can be made thinner and is much cheaper than a diamond boring tube, and for certain work is more suitable than the diamond drill, but for soft clogging strata of clay, marl, and other material, a shell boring bar, with steel cutters, is more satisfactory when worked on the percussion system, and, needless to say, a revolving shot or diamond drill would be at a disadvantage under these circumstances. There is, however, one advantage that has not been mentioned in connection with the latter type of boring machine which no other can claim—viz., the capability of drilling a hole under water without much difficulty, the tubular boring bar with its gem-studded crown enabling cores to be extracted from a great depth in this way for inspection. A form of rotary drill outfit is also commonly used in the oil fields, where a number of small holes are required in proximity, which is arranged on a carriage so as to be quite self-contained, and in some cases is even made self-moving. For portable boring machines an oil engine is found to be the most suitable and lightest form of power available, these being used to great advantage when the drilling is not carried to a depth much exceeding 200 or 300 feet. The boring bar used consists of a steel drill or bit of various form screwed on to a bar shaft, which is again screwed on to others as the hole deepens, the jointing being made by taper threaded connections. In other cases a tubular driving shaft is used, provided with a steel cutter crown-piece, this method enabling a stream of water to be forced down to the bottom of the well for the purpose of washing away the borings. Portable boring machines are also constructed to work on the percussion system, the derrick being much reduced in height; in machines of this type a solid bar

is jumped up and down on the end of the rope, to which motion is communicated by means of a walking beam worked from an oil engine. Yet another type of boring machine suitable for soft ground is fitted with an auger bit, such a contrivance being capable of boring down to 100 feet or so. In action the bit is rotated until choked, when it is raised by clutching into gear a winch for clearing, the operation being repeated until the desired depth is reached.

CHAPTER IX.

ARTESIAN-WELL OR BOREHOLE PLUNGER AND AIR-LIFT PUMPS.

DEEP borehole or artesian-well pumps may be said to consist essentially of a plain barrel hung in the water by a wrought-iron rising main of slightly greater diameter, the bucket plunger being hung by a pieced-up rod inside the rising main which projects through a stuffing-box contained in an anklet casting at the top of the main, which may be situated at the surface level or in a shallow well from which a borehole has been sunk; the pump barrel in all cases is a continuation of the delivery pipe, which is usually of a diameter to as nearly fill the well as possible. Such pumps are fitted with bucket plungers of one form or another, the suction end of the barrel being almost always carried down below the working level of the water in the well; this does not imply that the pump is at the bottom of the well, but rather that a borehole is continued down far below the water level. The depth at which water is to be found depends, of course, on the level of the "outcrop"—*i.e.*, the lowest point at which the water-bearing stratum meets the surface; or, in other words, it may be said that the level at which water rises in an artesian well—which, by-the-way, is often sunk to the bottom of a basin formation where water is held in a porous stratum between upper and lower impervious strata—depends on the height of the lowest point, where the edge, as it were, of the basin meets the surface or a porous stratum capable of draining water therefrom is reached. For borings in rock having a surface outcrop near the site of the boring, the water will not be much, if any, above the nearest water course crossing the seam; but where borings penetrate an impermeable stratum and reach a porous rock having a distant outcrop, the water level will be determined by this level, and the water level, though lower than the receiving surface, will be somewhat higher than the draining point. In some cases, as in certain parts of Lincolnshire, for instance, water will rise to within a few feet of the surface, and, indeed, the most copious supplies are always met with at levels not exceeding 300 feet down, the rule being such that the farther the boring is continued beyond this the less is the supply, although for other reasons it is often desirable to tube a boring for the first 200 or 300 feet, and continue it down far enough to reach another water-bearing stratum. Tubing, however, is not necessary in boring through hard sand or lime rocks, excepting to such depth as to prevent the inflow of surface waters. In ordinary circumstances it is usual in modern practice to case the upper and middle phases of the boring with stout, steel-socketed, wrought-iron or steel pipes to a point at least lower than the lowest water level; in chalk bores, as in the London district, the casing pipes are driven at least 10 feet in o the chalk, the socket projections effectually securing the shutting back of the upper and undesirable waters from the lower. The quality of water derived from artesian wells depends on the nature of the stratum holding it; this, of course, accounts for the water obtained from one part of the country being more suitable for certain manufactures than another. The temperature

of water drawn from deep wells increases about 1° F. for every 55 or 60 feet increase of depth below the first 60 feet, at which point, as a rule, water is found

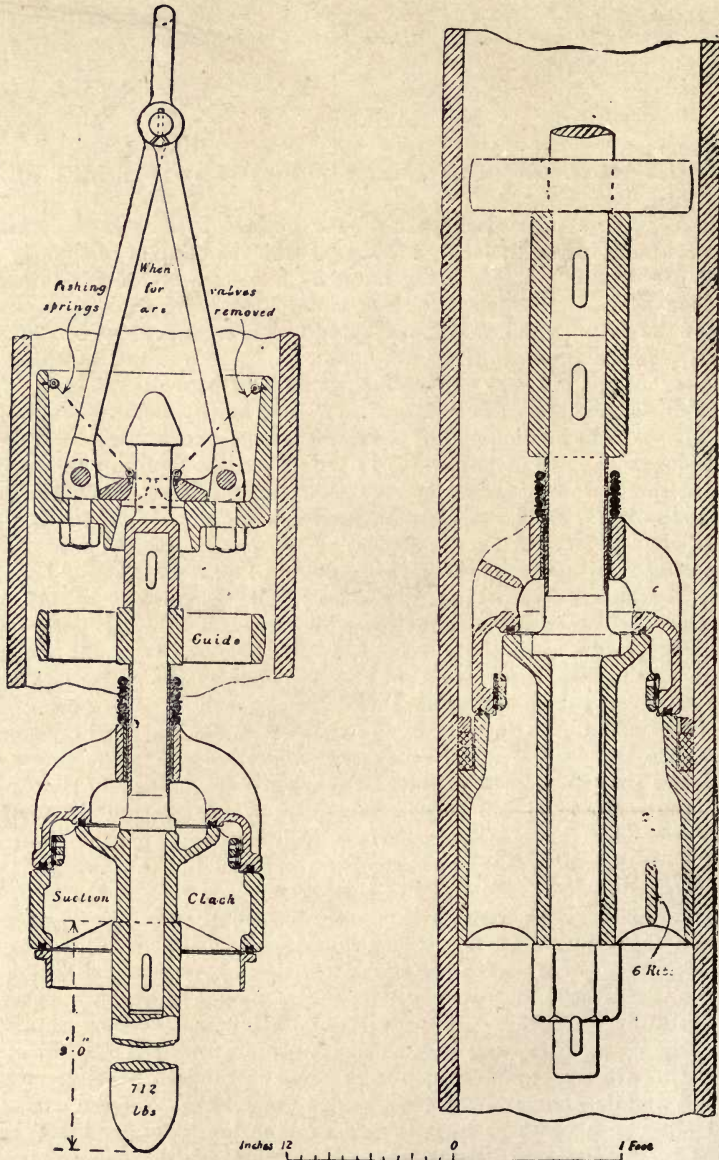

Fig. 62.—Artesian-well Pump with Double-seated Valves.

at a uniform temperature of 50° F. In order to increase the flow of an artesian well, blasting is sometimes adopted, with good results, the effect of this procedure

being to enlarge the well and loosen the water-bearing chalk or rock formation around the bottom of the well.

PLUNGER PUMPS.

Artesian-well or borehole pumps are actuated in several ways, the largest being often connected up in pairs to balancing quadrant levers, as illustrated by Fig. 31. This method, of course, necessitates the boring of two wells together; single pumps can, however, be balanced by a counterpoise or by using a double plunger arranged to work concertina fashion, but the most important differentiation in the various makes and types of borehole pumps consists in the particular method adopted for balancing the action of the water column and actuating mechanism. The method of boring two wells within a few feet of each other and arranging a pair of quadrant levers over these for actuating the plungers of the two pumps is a convenient and practical course to follow for pumps of large size, and a pair of such pumps can be efficiently worked by a triple-expansion engine of the type illustrated by Fig. 31. In connection with such pumps a form of bucket plunger and double-beat valve is used, as shown by the sectional cuts, Fig. 62; * this plunger, which is some 18 inches diameter, is packed with a rubber ring, and the double seatings of both head and foot valves likewise, the same method also being adopted for jointing the foot-valve casing; this, as shown, is held down by a long, heavy rod of some 7 cwts. An important consideration in connection with borehole pumps, when provided with a foot valve, is a convenient means of lowering the valve *in situ*, and for removing same for repairs or cleaning when required—a contingency to be reckoned with in some districts more than others on account of the “caving in” of sand from the boring below the casing. For this purpose a special form of grappling hook is used for engaging with the stem of the valve case, which is provided with a pointed cap, that also affords a shoulder for the spring snatchers of the grapples to hold on to. The plungers may be connected up to the quadrants by an iron rod or wood spear, a steady guide being, of course, fitted wherever two lengths are coupled together.

Obviously the worst feature in connection with the boring and equipment of artesian-well pumping installations, from an engineering point of view, results from the general unhandiness of many of the parts; on this account a high derrick and heavy lifting tackle is a desideratum that cannot be dispensed with, for assuming the wells to be already tubed, there remains the lowering down of the pump barrel and connecting same up to the several lengths of piping required for the rising main, all of which must be suspended from the anklet casting at the top; then again, in order to lower the plunger into the barrel, the rod has to be pieced up in several sections, according to the depth of the well, and requires much patience and skilful handling when dealing with pumps of large size.

Borehole pumps in single units are frequently arranged in the manner shown at Fig. 63, small pumps being driven in this way without any balancing effect. This installation is a good example of a gas-power well pump, and shows another method for balancing the 160 feet head of water on the up stroke. In this case a 2-throw crank (k, k) is used, the second crank being connected up to a heavy counterpoise (w) arranged to slide between guides; the pressure head above the pump is balanced in almost every case by the use of a ram at the head of the plunger-rod, and works water-tight in a gland at the top of the anklet casting

* From the Proceedings of the Institution of Mechanical Engineers, 1903.

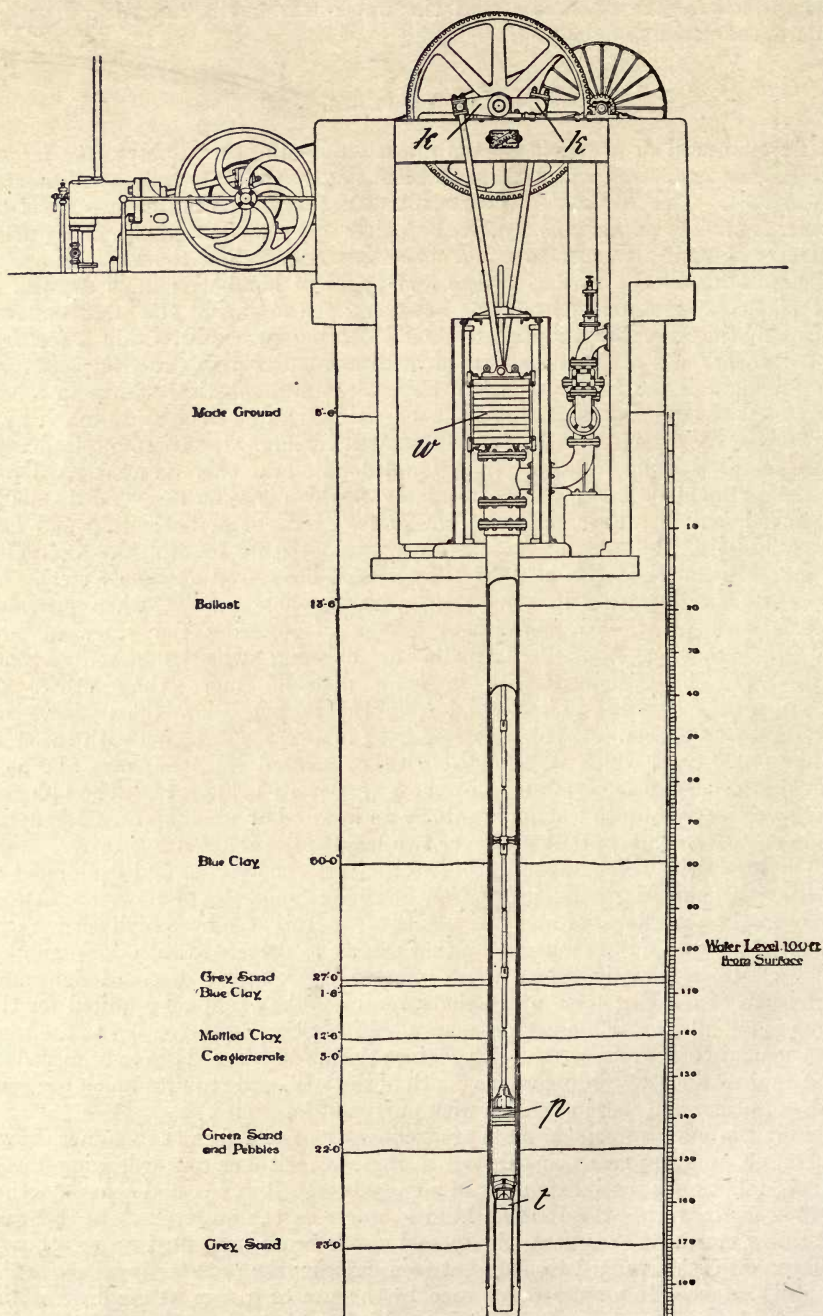

Fig. 63.—Gas-driven Artesian-well Pump, with Counterpoise Balancing Action.

in the usual way (*vide* Fig. 34). The plunger and valves are constructed practically identical in form, as shown in Fig. 62, the foot valve being nearly 60 feet below the water level, and about 240 feet from the bottom of the well. The illustration, Fig. 63, of an Isler gas-power gear-driven pump of the counterpoise type, also shows the disposition of the strata underlying London.

Another method of balancing a borehole pump is illustrated by Fig. 64, and is one that lends itself to being driven from a direct-acting steam engine; in this,

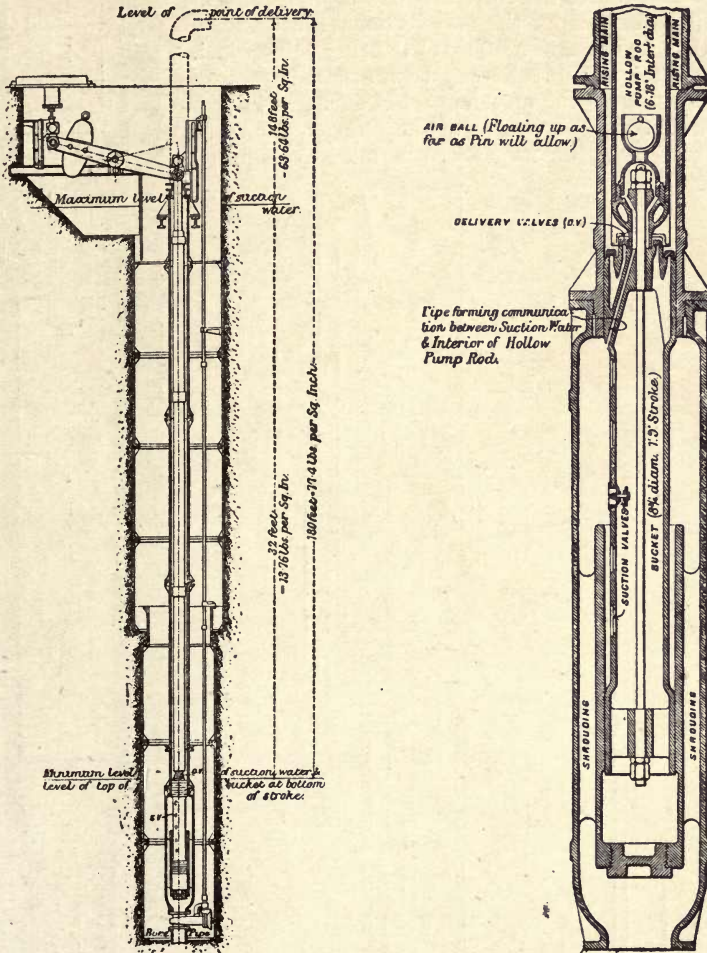

Fig. 64.—Ashley Balanced Deep Well Pump.

the Ashley deep-level pump, the weight of the water column, plunger, and rod are balanced by a weighted beam; and in the working of this pump, not only are the water column, plunger, and rod balanced by the counterweight and beam, but this is corrected for the difference in suction level also, which is an improvement of some importance when the relative proportion in the difference of water level is great to the total lift. The form of plunger used is identical to that shown at

Fig. 36, and will not, therefore, need further description. The peculiarity of the Ashley balancing arrangement consists in the use of a tubular plunger-rod of practically half the area of the plunger, and as water direct from the well is free to flow into this tube, the level therein is caused to coincide with the level in the well — *i.e.*, within the limits of the distance between the level of the delivery valve and the top of the well; the tubular rod is also provided with a ball valve situated immediately over the double-seated delivery valve on the plunger head, and it will be seen from the two sectional illustrations, Fig. 64, that by the action of this balancing valve, which is hollow, water in the tube can be prevented from returning back during the up stroke; but during the down stroke, owing to the movement of the plunger, the valve will rise sufficiently off its seat to permit any required

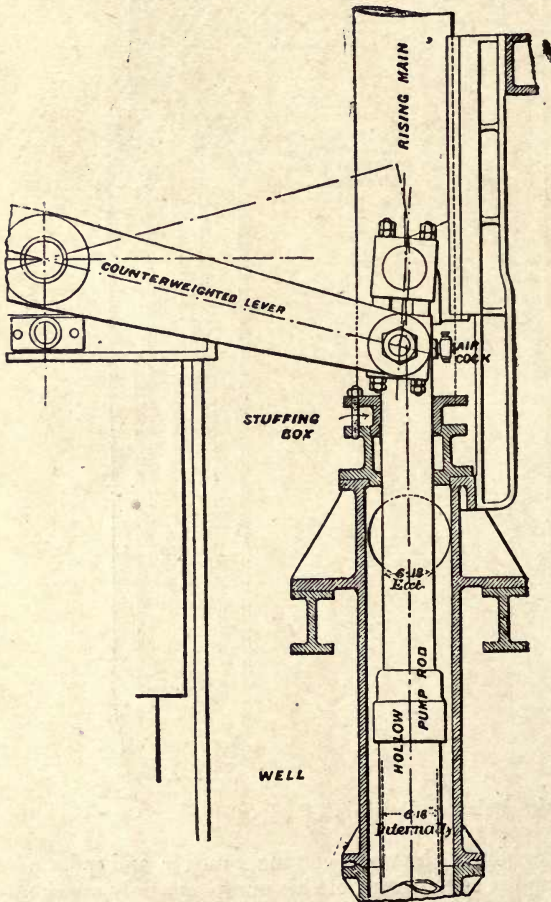

Fig. 65.—Details of Ram Plunger used in Ashley Double-acting Balanced-action Deep-well Pump.

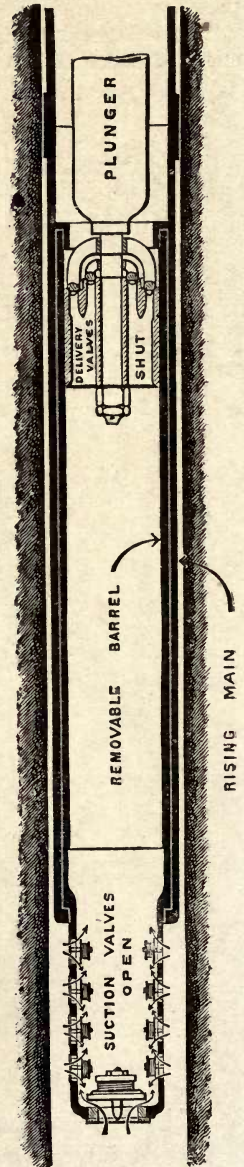

Fig. 66.—Modified Form of Ashley Deep-level Pump with Removable Barrel.

equalising of the water level inside the rod and the level in the well ; so that it follows that supposing there to be a difference of level of, say, 20 feet in the well, an ordinary pump would work unbalanced to this extent. With this arrangement, however, the effect of an increase of 20 feet in the level of the well water would be compensated by the 20-foot column of water in the rod acting against the up stroke and in assisting the down stroke, the area of the column being practically half the area of the plunger ; and again, supposing a difference of level of 10 feet below normal, there will be 30 feet difference in the tube—*i.e.*, the level therein will be the same as outside, and consequently in place of having an extra load equivalent to 20 feet of water there will be a reduced load of 10 feet on the up stroke and a corresponding difference on the down stroke, which together balance the 10 feet reduced level in the water outside the pump. At the top of the pump, *vide* Fig. 65. there is a ram plunger which balances the high lift, and, of course, causes this end of the pump to be double acting in the usual way. In order to obtain the correct balancing effect, the water level must not fall below the level of the ball valve, as below this the tube has no effect whatever ; and besides, any advantage of balancing the difference of suction level in this way has one or two off-sets : (1) The delivery valve at the head of the plunger is reduced instead of increased in waterway area ; (2) the waterway area in the rising main is also reduced, being about half the area of the plunger.

The principal advantage of the Ashley form of deep-level pump consists in being able to dispense with the foot valve, thus enabling both valves and plunger to be removed from the well at one operation ; and thus obviates the trouble and delay often caused in grappling for the foot valve seat. In another pattern, *vide* Fig. 66, this pump is modified in construction to enable the working barrel as well as the plunger and valves to be drawn up for renewal or repairs. In this form the suction valves, instead of being in the pump casing, are fixed round the bottom end of a liner constituting the working barrel ; this barrel is surrounded by a shroud communicating with the borehole suction pipe, the bottom of the liner being closed ; the plunger is of the piston type, but differs from the ordinary practice in being provided with hollow stems projecting above and below ; these carry two sets of multiple delivery valves, the action of this pump being as follows :—On the up stroke of the plunger water enters by the valves in the liner to the space underneath the plunger, and on the down stroke is forced past the valves in the stem below the plunger, and out again past the valves in the upper stem, and thence into the rising main, which is slightly larger than the liner to enable it to be drawn up to the surface without having to dismantle the whole of the pump.

However, the Ashley method of arranging multiple valves on the plunger shows to best effect in the double-acting concertina type of pump, as illustrated by Fig. 67, which is a modification of a method often used for obtaining a balanced action in a double-acting pump, and is very applicable to the single barrel of an artesian well. The concertina pump, as before explained in connection with the borehole pumps at the Streatham Water Works, consists essentially of two independent bucket plungers, each provided with a lift valve, the two plungers being actuated so as to approach and recede from one another concertina fashion, hence the name given to this style of pump. No foot valve is necessary, the valve in the bottom plunger serving this purpose, and opens as the plungers recede from one another, thus admitting water to the space between the plungers produced by their movement away from each other, when this volume of water is forced through the upper plunger on the next stroke ; half the volume thus forced past the valve in the upper plunger is delivered at

the surface by the up stroke of the lower plunger and one-half during the up stroke of the upper plunger, the pump being thus double-acting at the delivery end ;

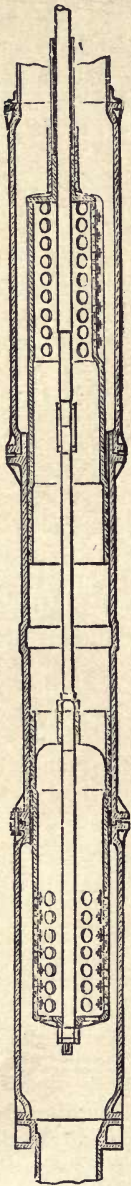

Fig. 67. — Double Plunger Balanced Deep - well Pump with Ashley Valves.

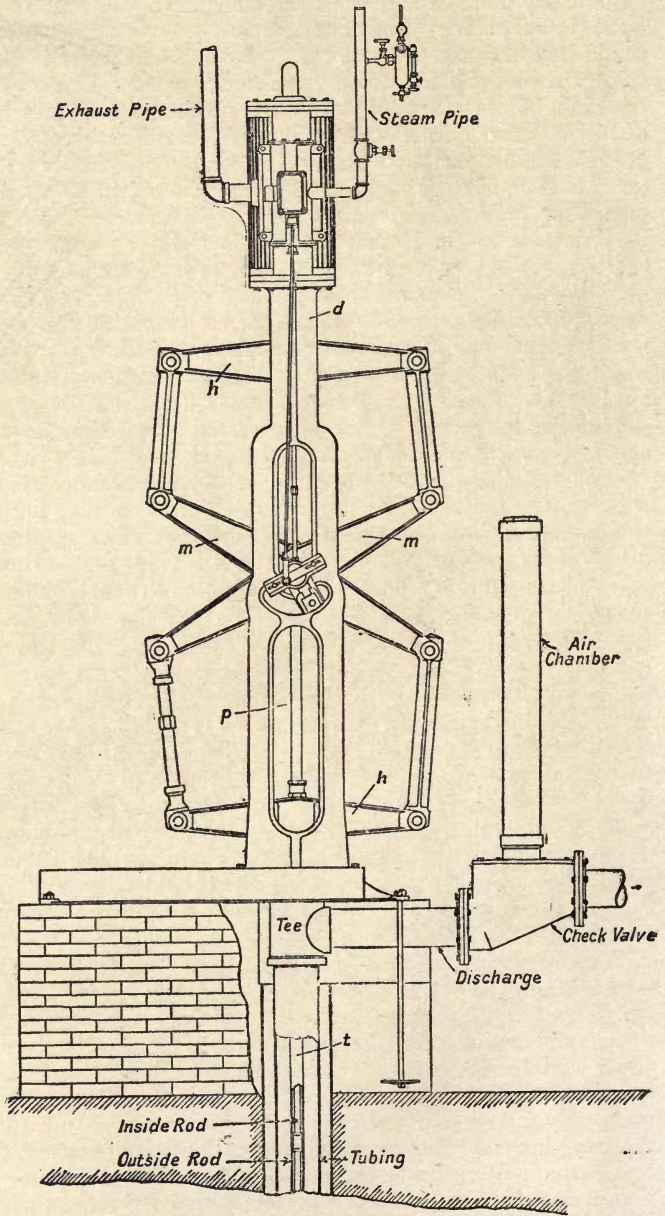

Fig. 68. — Downie Double-acting Direct-connected Steam Borehole Pump.

and further, as each plunger may have a full stroke, the capacity of such a pump is double that of an ordinary single plunger pump. There are thus to be seen three distinct advantages pertaining to this class of pump—viz., (1) it is double-acting, (2) it is entirely balanced, and (3) it is double the capacity of an ordinary pump, the capacity being only limited by the waterway area of the plunger valves. In the example presented at Fig. 67, an increased plunger speed is practicable, due to the large area of waterway afforded by the multiple suction and delivery valves shown; the working barrel is also jointed above and below to casings of a larger diameter and forms, respectively, continuations of the suction and delivery pipes provided for receiving the plunger extensions according to the Ashley system before described. The motion for the lower plunger is communicated by a rod passing through the upper plunger, which in turn is actuated by a tubular rod, the two rods being either connected to the arms of a pair of quadrants or to a balancing disc, as shown by Fig. 30; or may be driven by a direct-acting engine, as shown at Fig. 68, which consists of a vertical engine with direct-acting cylinder of the steam-thrown simplex type, carried on a pair of rather tall standards (*d*) for the purpose of accommodating the two crossheads (*h*) and pair of beams (*m*) used for communicating an up and down motion simultaneously; in this case the solid rod (*p*) is connected to the piston-rod direct, and the tubular-rod (*t*) to the bottom crosshead, and affords a compact and certainly unique arrangement for this purpose. In connection with the double-plunger, double-acting, form of artesian-well pump, may be pointed out the advantage gained in being able to dispense with the foot valve, thus avoiding much of the trouble often caused by sand, which together with its perfectly-balanced action goes far to make up for the extra mechanism entailed by the use of two actuating rods.

The double piston pump has the further advantage of working with a full displacement or delivery at each stroke, from a single well, which is a very important consideration, wells more often than not supplying more water than can be raised by a single-acting plunger pump. In regard to economy in steam consumption, there is no advantage in using a direct-acting engine, as shown in Figs. 68 and 70, owing to the limitation of piston speed; but, on the other hand, it is very much quieter in action and requires less floor space than a geared double crank steam, oil, gas, or electrically-driven pump.

A point of some importance in the working of a double piston pump is due to the wear and friction of the inner rod at the gland-packed head of the outer tubular rod, this in usual practice being just left to run in water. In the Downie double-acting pump the space between the two rods, as shown in Fig. 69, is filled with oil, which being slightly lighter than water is prevented from escaping down into the water column to any very appreciable extent, a gallon or so per week sufficing for the make up. Another consideration in deciding on the relative merits of a double *versus* a single plunger deep-level pump results from the increased plunger speed that a double-acting pump with two plungers can be run at, owing of course to the continuity of motion of the water column, thus a double plunger pump has a capacity, not double, but three times or even greater, than a single plunger pump of the same diameter and stroke.

The direct-acting vertical borehole pump with floating spear-rod is essentially of American origin (the first of this type being the Smith-Vaile), and is a form of pump that certainly affords a very simple and effective means for raising water from a borehole, especially in such cases where the depth of the well does not exceed 500 to 700 feet or so, as the unbalanced weight of the moving parts, notwithstanding that a considerable proportion of the total weight is floated by

the water in the rising main would soon become excessive; the connection between the upper ram and the bucket in this type of pump is made by a series of wood rods of large rectangular form, which are firmly bolted and strapped together at their ends. Careful attention has in many respects been paid to an improved proportioning of the various parts in the A. C. Potter pump of this type, which has been supplied in great number to users up and down the country for artesian wells ranging in size from 8 to 18 inches diameter, with a length of stroke for all sizes of 3 feet, and a working speed of about 20 double strokes per minute, although capable of being forced up considerably beyond this as occasion may require. The means adopted for the steam distribution

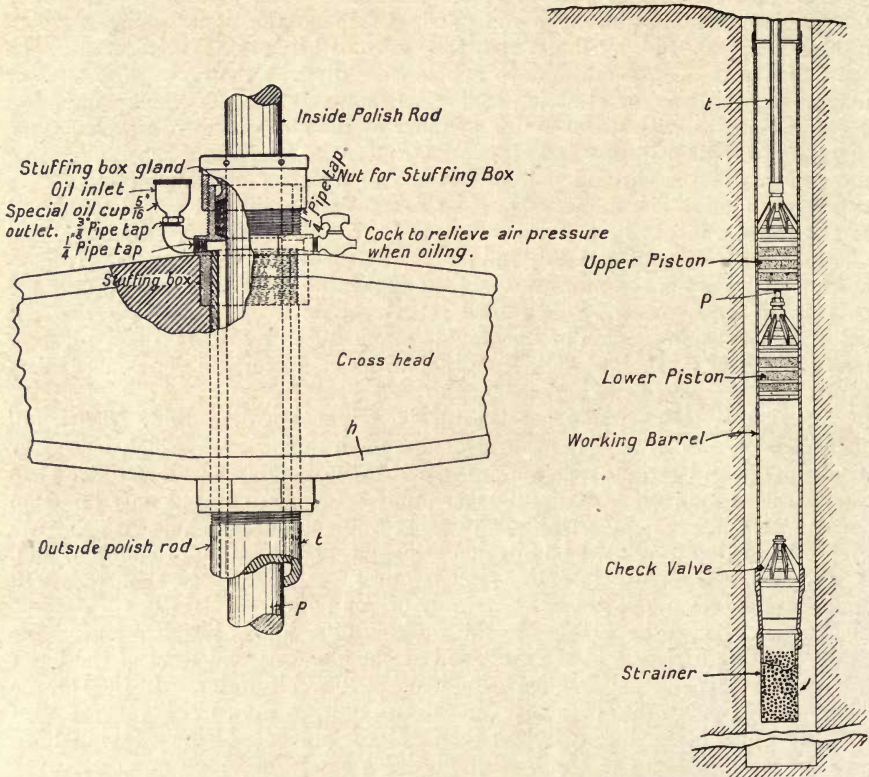

Fig. 69.—Details of Crosshead and Plunger Connections of Downie Double-acting Borehole Pump.

in the engine cylinder will be recognised as being on the steam-thrown valve principle used in variously modified form in engines of the simplex class. The weak point in this very simple direct-acting construction of artesian-well pumping engine struck the writer as being due to the absence of a balancing action; however, a factor is present wherewith in considerable degree the lack of balance is compensated for—viz., hydraulically by means of a double-acting ram delivery, and, mechanically, by the lighter than water connecting-rod—and judging from the working of one of these pumps at Queen Anne Mansions, Westminster, any deficiency in this respect would seem to have been well compensated for

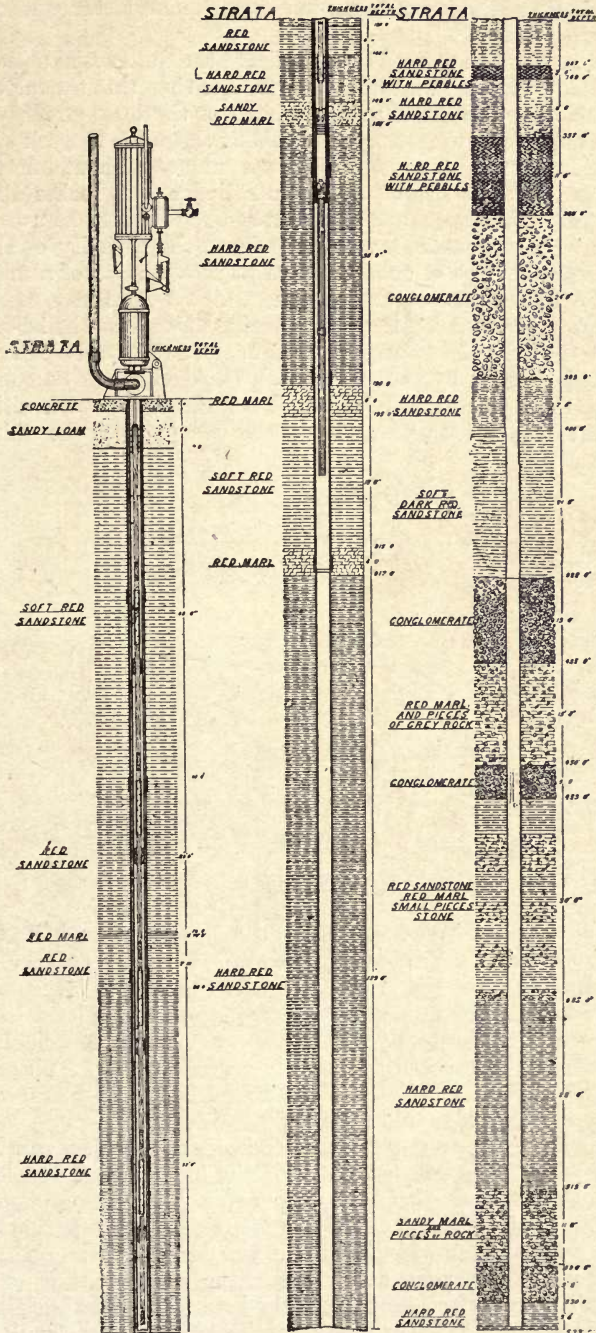

Fig. 70.—Section of Artesian Well, showing Direct-acting Steam Pump.

although the depth of the pump barrel in this particular instance is some 230 feet down.

The diagrams shown at Fig. 71 will indicate the differential action obtaining on the up and down strokes without saying further than that the method adopted consists in cushioning and throttling the exhaust on the down stroke, which simple means successfully serves the purpose of enabling the pump to work with a regular and quiet action from 5 up to 25 strokes per minute without knock or sign of being over speeded. The size of the steam cylinder is $9\frac{1}{2}$ inches diameter, and the pump barrel $7\frac{3}{4}$ inches diameter, with a stroke of 3 feet, as usual in engines of this make. At 18 double strokes per minute the capacity of this pump is 10,000 gallons per hour—i.e., about equivalent to a quarter of a million gallons per day. The description of this engine, which by-the-way resembles very closely in appearance and working to a vertical simplex “boiler-feed pump,” is as follows:—In the two steam ports and in the down stroke exhaust port are inserted throttling plugs, by means of which the engine can be controlled to a nicety both on the up and down strokes, it being usual to work with the steam supply full on to the valve chest. There are five ports in the slide-valve face

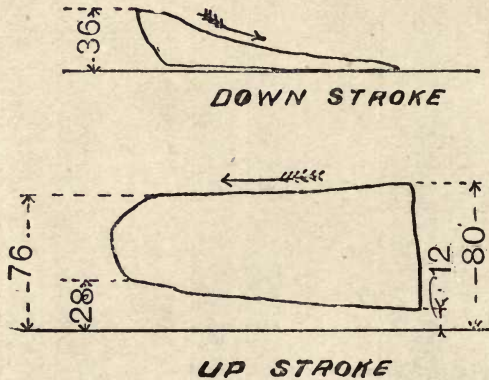

Fig. 71.—Diagrams from Direct-acting Artesian Well Pump.

as used in duplex pumps (*vide* Fig. 108) for the purpose of reducing the travel of the valve. At the side of the slide-valve is a piston valve, the two being connected by an arm. In action the slide is traversed by the outside lever mechanism in the usual way for a short port opening, when steam is admitted to one end of the piston valve, with the result that it shoots over and so quickly completes the travel of the main distributing valve in either direction. There is no difficulty at starting, partly due to the pump barrel being below water level, thus avoiding the possibility of running empty.

The construction of the pump itself is in accordance with the ram and plunger principle, the pump being single acting for the low lift and double acting for the high lift; this, of course, to some extent gives a balanced action varying in degree as to the relative height of the low lift to the high lift, there practically remaining the weight of the water column in the borehole rising main in addition to the steam piston-rod, ram, and plunger, the spear rod being practically floating and all over surface head perfectly balanced. The bucket plunger is packed with three or four leather rings, each held in place by a junk ring, which is threaded over the plunger; in practice, these rings wear for years, and are

practically water-tight. The bucket plunger is fitted with a ball valve, which although affording much less waterway than either the Ashley method or the Downie multiple-seated valve shown in Fig. 67, has, nevertheless, one advantage, and is found to give less trouble from sand and grit than the double-beat valve; further, its use obviates considerable inconvenience on this account at starting a pump in a newly bored well; the suction valve is also of the ball type, and being fitted with a cage can be easily grappled for as occasion may require.

It may be mentioned that the degree of throttle and cushioning required in the steam cylinder on the bottom end is proportionate to the depth of the well, and the amount of steam used to raise the plunger is reduced to this extent as shown by the diagram, Fig. 71, while the down stroke with the pump in smooth working order may require little or no steam whatever. The sectional drawing, Fig. 70, of a borehole sunk in the Birmingham district, affords a much clearer conception of the proportion of an artesian pumping engine in point of diameter to depth than words can convey. This well is bored 14 inches diameter, and tubed down to the bottom of the lowest stratum of marl—*i.e.*, to a depth of 217 feet—below which the bore is reduced to 12 inches diameter. The diameter of the pump barrel, which extends down to the 170-foot level, is $9\frac{1}{2}$ inches, the suction, or rather the inflow pipe, being continued another 30 feet. This well was bored by means of a rig, as illustrated by Fig. 61, and extends to a depth of over 530 feet; indeed, this same method has been used for boring a well, down to a depth of 1,500 feet, the diameter being 4 inches only at bottom, the difference of diameter at the top depending on whether the well has been tubed in one, two, or three stages, as the tubing for each stage must pass down within the casing immediately above, and thus determines the diminishing diameter as the bore proceeds. To give some idea of the enormous length of the steel-driving tubular shaft, it may be said that in a well of this depth as many as 75 separate lengths of tubing each of 20 feet, have to be screwed together in order to communicate motion to the rotary boring tube at bottom; and the elasticity of this shaft is such that as many as 7 or 8 revolutions may be imparted to the driving cramp before the boring tube commences to move. Consequently every precaution is required to prevent the driving shaft from being twisted in twain, and on this account is always driven by a belt proportioned in width and tautness to slip immediately too great a pressure is thrown on the boring tube, or, as may happen in cutting through a stratum of clay or marl, when the boring tube is liable to be held tight by the squeezing in of this softer and somewhat plastic material.

The borehole pump illustrated by Fig. 72 is interesting in being double acting, an effect that is ingeniously obtained by the use of a single plunger. It may be gathered from the illustration that a movable-pump barrel is used in which both top and bottom valves are of smaller diameter than the inside diameter of the column or rising main, and can be pulled up together with the plunger for repairs in a similar manner to that shown in Fig. 66. The peculiarity of this pump consists in discharging at full capacity on the down stroke as well as on the up stroke; the pump, therefore, is of twice the capacity of a single-acting pump of a given size and speed. The barrel and hollow plunger rod are of seamless brass tubing, and all other parts cast brass; the three annular valves are best rubber—*i.e.*, the valves at top and bottom of the barrel and the valve over the plunger—there is also a hollow-brass ball valve controlling the discharge from the central tubular rod, which latter is packed with special flanged-leather rings, where it passes through the top and bottom valve seats. The action of this pump is as follows:—On the up stroke

the annular-rubber suction valve below the plunger opens, and the space between it and the plunger is filled, and at the same time the discharge valve under the rising column is opened and the water between it and the plunger is forced up into this. On the down stroke, the two annular valves referred to close and the valve over the plunger opens—*i.e.*, the down stroke suction valve—and water is drawn through the hollow plunger-rod from the suction pipe not shown, and passing up through the plunger fills the space above the plunger; at the same time the ball-discharge valve opens and the water below the plunger is forced up through the hollow rod connecting the plunger with the ball valve-seat casting and rod connection, and thus into the rising main; it will thus be seen that there are four valves in all, and one double-acting plunger.

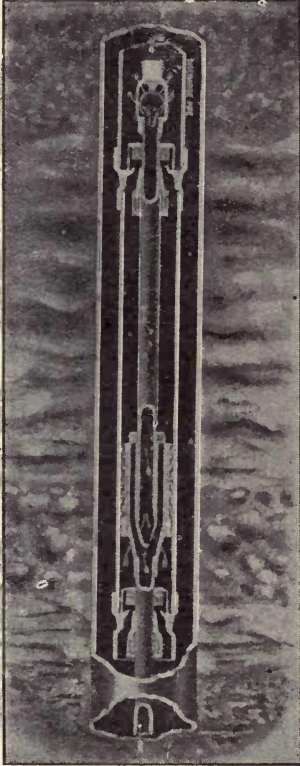

Fig. 72.—Double-acting Single Plunger Borehole Pump

In concluding the consideration of plunger pumps in their application for raising water from deep wells, it must be again emphasised that from the point of view of economy in fuel consumption, the geared pump has an undoubted advantage over the more simple direct-acting steam-driven pump, the geared pump having the further advantage of being adapted for being driven by gas or oil power, a feature of special value when the pump is only required to be worked for a portion of the day; and, in any case, this class of pump does not require a greater power than can be supplied by the more convenient and economical internal-combustion engine.

AIR-LIFT PUMPS.

The method of raising water on the aëration principle has been very extensively applied to artesian wells, the number of air-lift pumping installations in use being the more surprising considering that this method does not lend itself to a high economy. Its popularity can only, therefore, be accounted for (1) by the extreme simplicity of the under-surface mechanism; (2) to an absolute immunity from the scouring and choking effect of sand; (3) to the short time required for setting up the necessary plant to start pumping operations, it being convenient to utilise temporarily the steam boiler and engine forming part of the boring plant in ascertaining tentatively the water supply value of the boring

before putting down permanent plant; a preliminary test can thus be carried out by this means before removing the boring derrick, to ascertain whether or not it would be desirable to continue the boring to a lower stratum. In order to obtain a trial run on the air-lift principle it is not necessary to fix the machinery immediately over the well; indeed, this is one of the salient advantages claimed for the air system, that the compressing plant may be located at any point adjacent without materially affecting the efficiency of the working; a compressor, moreover, can, if required, be connected up to more than one well. A well fitted up with pumping plant on the air-lift principle is first tubed or cased

in the ordinary way to prevent inflow of surface water; over this tube is jointed a head-piece casting, and suspended therefrom are two pipes, one serving for a discharge pipe and one for conveying the air down to the discharge nozzle, both pipes being continued down below the surface of the water in the well to a depth equal to or slightly greater than the height of the lift from the water level to the outlet level of the delivery pipe.

There are several ways of arranging the compressed air and discharge pipes down within the tubular casing of the well: their disposition may be either concentric—*i.e.*, with the air pipe arranged within the water pipe, or *vice versa*; or the two pipes may be carried down separately to the required level, the air pipe being bent at its bottom end to project up within the open mouth of the rising main. When, however, the air pipe is suspended alongside or within the ascension pipe, this may conveniently have attached to it at the bottom end a mouthpiece of slightly enlarged diameter, so as to accommodate a multiple ring discharge nozzle at the end of the air pipe, formed to deflect the air current upwards, and at the same time to distribute it over a wide surface, thereby having the effect of reducing the resistance of inflow. By this means the water entering the enlarged mouth of the uptake is thoroughly aerated, and being thus reduced in density ascends with a velocity depending on the volume and pressure of the discharge. The action of the compressed air may be compared to the violent ebullition produced in a vertical or slanting tube of a water-tube boiler when exposed to fierce heat; it is, however, not *de rigueur* to discharge the compressed air into the water pipe in a number of fine jets or in an annular stream, as, for instance, the discharge or uptake pipe may simply terminate open-mouthed in the centre of a larger pipe used to conduct the air down, the air pipe in this case being continued down to a lower level, although not essentially necessary. The top of the well casing must in all cases be sealed to prevent water from being carried up and overflowing at the surface.

There is no definite limit to the depth to which an air-lift pump may be applied, excepting the limit ruled by expediency. The greater the depth the greater the pressure of air required, this factor by reason of the decreasing ratio of efficiency of compressors tending more than any other to determine the height of lift possible in actual practice; in some rare instances water has been raised to the surface from a depth exceeding 1,000 feet, but is more generally confined to lifts of two or three hundred feet or so. The working pressure of air found to give the most economical result is approximately .65 lb. per square inch for each foot of lift from the surface of the water, and the volume of compressed air required at the discharge nozzle is approximately 1 cubic foot for every 8 to 12 gallons raised, the efficiency varying considerably in some cases, and is influenced by the proportions of pressure of air to immersed depth of nozzle, to shape of nozzle, diameter of discharge pipe and other factors, the volume of air required at the nozzle being practically the same for all lifts. Thus for a 50-foot lift, air at about 33 to 35 lbs. per square inch pressure is required; for a 100-foot lift, 65 lbs. air pressure; 150-foot lift, 95 to 100 lbs., and so on; the use of air pressure in excess of this results in a greater waste of power, notwithstanding that a greater volume of water can be lifted thereby, and the effect of decreasing the air pressure is to diminish the volume of water raised until a point is reached at which no water is delivered, the air finding its way up through the water column to the outlet.

The low efficiency of an air-lift pumping installation is influenced to a considerable degree by the filtration, as it were, of the air in fine bubbles up through the water column, the action resulting from the discharge of the air in a diffused

state into the surrounding water of an uptake not being comparable to an enclosed vessel from which water could, of course, be forced to a great height with an efficiency depending entirely on the perfection of the compressing plant. In the raising of water on the aëration principle this is not so, as the power capable of being utilised in terms to be expressed in water horse-power—*i.e.*, in actually lifting water against the force of gravitation—is rarely much greater than half the power represented by the volume of air discharged at the nozzle, notwithstanding that the air expands under conditions seldom realised in an air motor—*viz.*, in being supplied with heat from the water and maintained at constant temperature. The net efficiency of an air-lift pump is more often less than one-third of the power expended in compressing the air than above this figure, and rarely exceeds 35 per cent., the loss of power between the prime mover and the compressor piston representing some 10 to 25 per cent., according to size, method of driving, construction, and other conditions relating to the compressor; the loss resulting from mechanical friction, however, may be debited at a maximum of 15 per cent. in a good compressor, and the loss resulting from compressing the air above the isothermal line, variously at from 20 to 40 per cent., it being quite evident that none of the heat imparted to the air during compression can be utilised, and that it will immediately fall to the temperature of the water on being discharged at the nozzle, if it has not already done so during its passage down the air pipe.

In order to emphasise the amount of power required to compress air at increasing pressure and volume as against that necessary when the temperature is maintained at a constant degree, it may be stated that the difference in the power to be expended in moving the compressor piston under these conditions results in average cylinder pressures as follows:—For constant temperature, 17·9 lbs. per square inch, as against 24·3 lbs. for adiabatic or increasing temperature, when delivering air at 35 lbs. pressure, the difference being from 24·8 to 38·1 lbs. for delivering at 65 lbs.; and from 30·2 to 51 lbs. for delivering air at 100 lbs. pressure—*e.g.*, in the last instance a compressor would indicate 30 horse-power when delivering at constant temperature, and 51 horse-power if no heat were carried away from the cylinder during the process of compression. It is due to this difficulty of keeping down the increase of temperature during the process of compression that compressors with small cylinders work with a higher efficiency than larger ones, and also explains why it is advisable to compress in multiple stages with inter-coolers when supplying air at pressures above three or four atmospheres; the rise in sensible heat resulting from compressing air to 105 lbs. per square inch—*i.e.*, 7 atmospheres—is 490° F., at which temperature the volume is doubled, and the resultant compressed air, instead of occupying a space equivalent to one-eighth of the original volume will occupy one-fourth; it is very evident, therefore, that careful attention should be paid to cooling the air thoroughly during compression. Compressors, unlike internal combustion engines, should be run slow, a piston speed of 100 to 150 feet per minute being very suitable, although exceeded in many instances to more than double this. All compressing cylinders should be thoroughly water jacketed, both round the barrel and covers; and water-cooling of the piston and rods is a further advantage in the larger sizes. Even with every precaution air may leave the compressor at a temperature sufficiently high to vaporise lubricating oil, and often gives rise to explosions in the receivers, especially when oil has been used too lavishly. As an instance of the inadequate cooling capacity of the ordinary compressor may be mentioned the case of a compressor having a cylinder 20 inches diameter by 33 inches stroke coming within the

writer's own experience, which, while delivering air at 60 lbs. per square inch only, registered a temperature of 314° F. higher in the delivery valve chest than in the suction box. The piston speed of this machine was, however, nearly 450 feet per minute—capacity being of greater importance than economy. It none the less demonstrates the insufficiency of simple water jacketing to keep down the temperature to anything near that of the cooling water. Now, if all loss of power from this cause could be avoided, the general working efficiency of an air-lift pumping installation would be measurably improved. One way of minimising the incapacity of water jacketing is by using water injection, which in a suitably constructed compressor has no deterrent effect in this particular application; or, as an alternative means, the compressor piston may be entirely immersed in water at one end—*e.g.*, a compressor arranged compound and single-acting coming under the writer's experience, was constructed with its two pistons, cylinders, and valve casings all in water, the pistons being packed with leather rings, hydraulic plunger fashion, and although worked at a piston speed of 250 feet per minute, and delivering air at 1,000 lbs. per square inch, the rise of temperature at the delivery valve only exceeded that of the cooling water by 70° F. However, in the case of the air-lift pump, we must look for expediency rather than for any other factor to explain the *raison d'être* of its use, the question of economy being entirely subordinated to the other recognised advantage in being able to dispense with sub-surface mechanism. Taking the case of one make alone—*e.g.*, the Isler—we find that there has already been installed over 80 air-lift plants in this country, of an output capacity varying from 5,000 to 60,000 gallons per hour; two pumps, for instance, at the Dartford station of the Kent Waterworks are capable of lifting 100,000 gallons per hour—*i.e.*, equal to nearly 2,500,000 gallons per diem.

The following illustrations and description will serve to make the construction of this class of pumping machinery sufficiently clear. The concentric arrangement of discharge and air pipes is shown in the air-lift hotel pumping plant, illustrated at Fig. 73, the lift in this case being 105 feet to the surface, with an additional 20 feet to an overhead tank. In this pump the air pipe surrounds the discharge pipe and extends down to 334 feet below the surface, it being thus continued down 66 feet below the bottom of the discharge pipe, and is a practice adopted to prevent sand from accumulating in the well. Not that much trouble is experienced in the chalk from silting up with sand; it, however, is very useful in the Tunbridge Wells district, for instance, where the formation is practically all sand. In this method of arranging the pipes for an air lift, it will be noted there is no special form of air nozzle, the discharge pipe simply dipping down into the air pipe to a depth of 140 feet below the level of the discharge tank, and 100 feet below the surface of the water in the well. In the example shown at Fig. 74, quite another arrangement of air and discharge pipe is used—*viz.*, the air and water pipes are separately suspended within the iron casing lining the well side by side, the air pipe bending up within the bottom of the delivery pipe, and is fitted with a nozzle cap to cause the air to be diffused, an improvement having some advantage over the simple method of discharging the air into the mouth of the delivery pipe in one unbroken stream. In both these air-lift installations the compressors used are of the Rand-Ingersoll type, there being in the second example a high-lift pump used to distribute the water raised to a sump tank by the air lift to the various baths in the building; the capacity of this pump is 15,000 gallons per hour, a duplicate plant of the same capacity being provided. The water level in each of these wells is 180 feet down—*i.e.*, the rest or static level—the working level being 10 to 25 feet below this

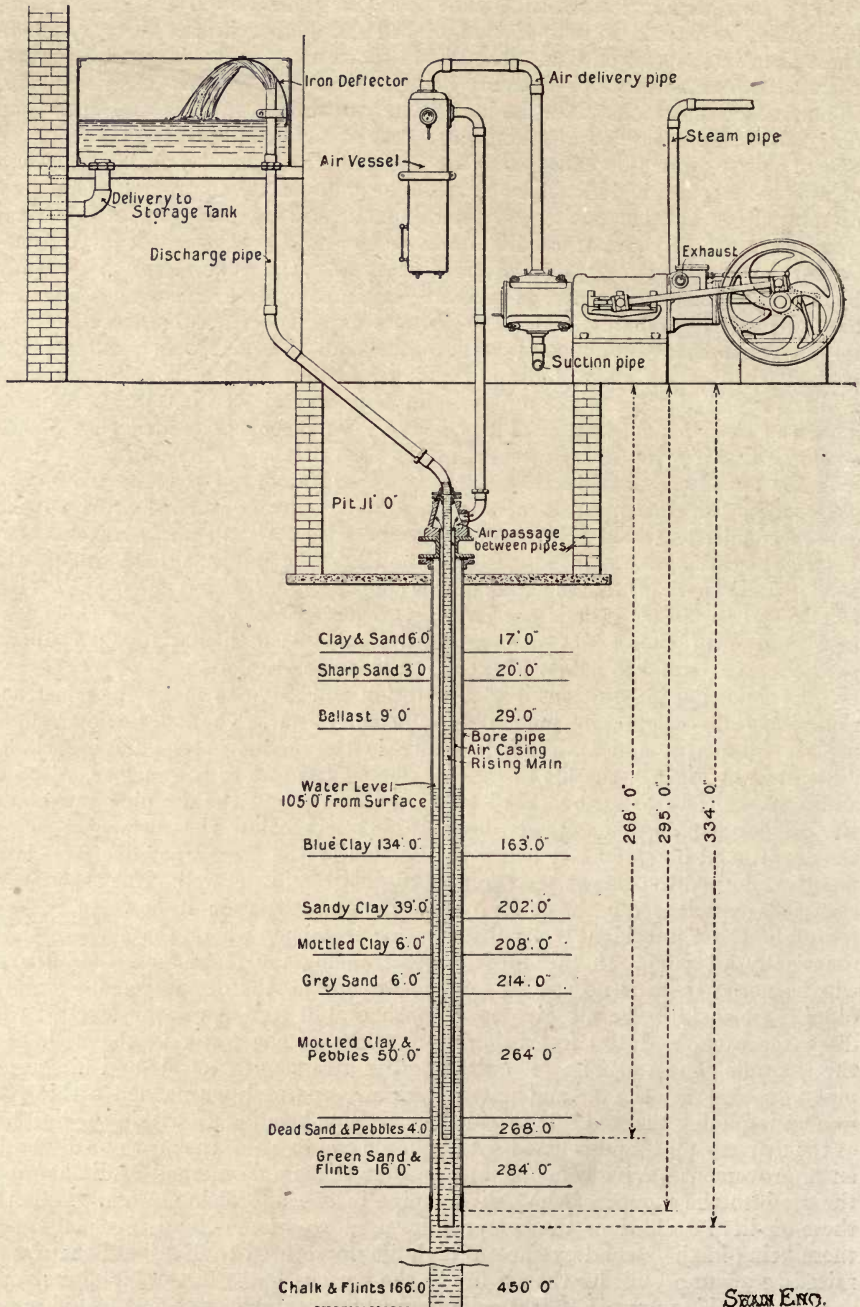

SEAMAN ENG.

Fig. 73.—Artesian Well Air-lift Pump.

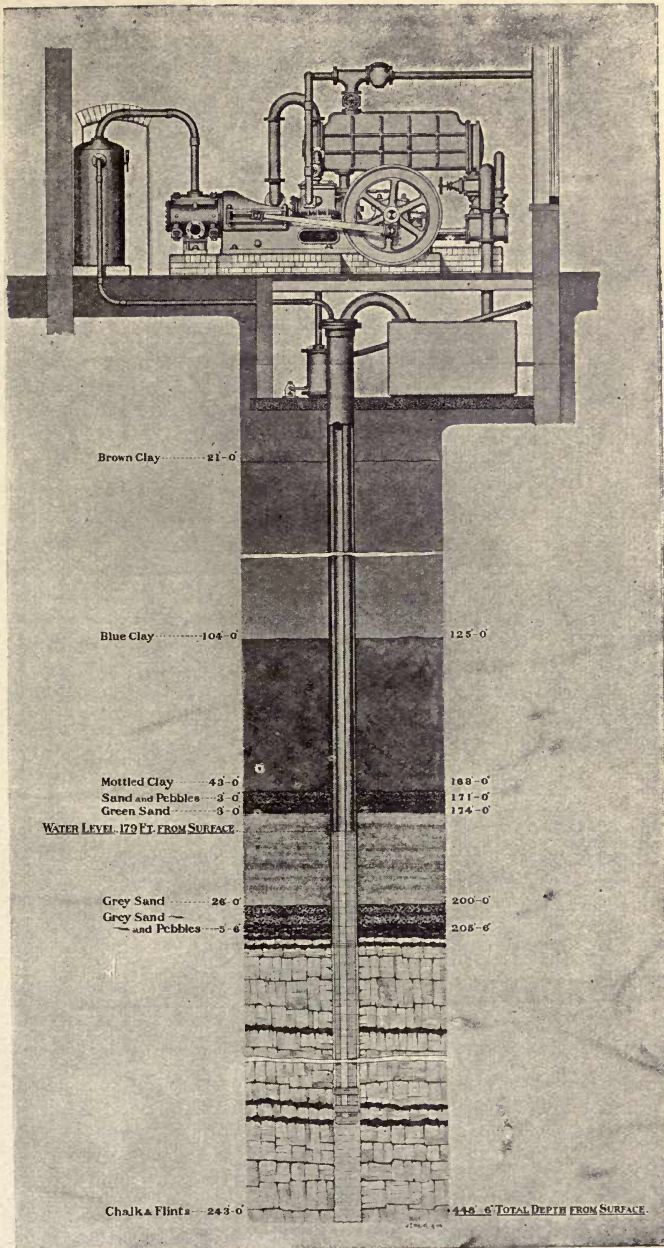

Fig. 74.—Artesian Well at the Prince of Wales Road Public Baths, London, N.W., showing Steam-driven Air-lift Pump.

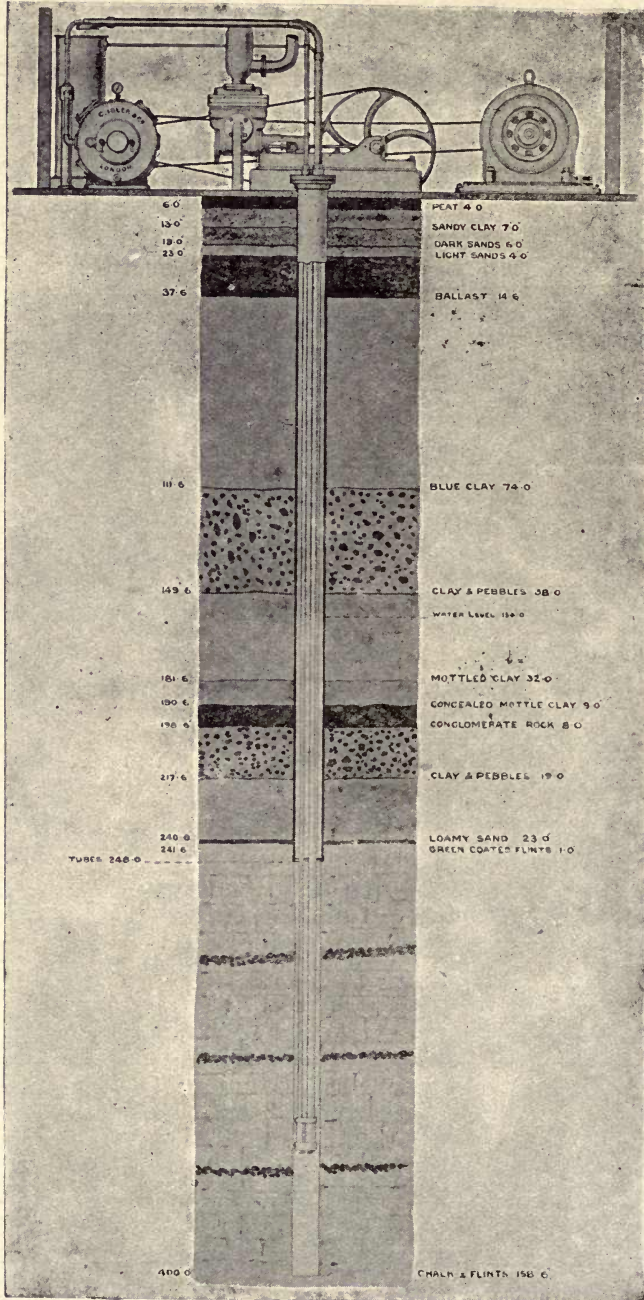

Fig. 75.—Artesian Well at Caxton House, Westminster, showing Electrically-driven Air-lift Pump.

according to the season, this depth necessitating a length of air and discharge pipes of nearly 400 feet; and extends to within about 50 feet of the bottom of the well in each case. In another application, shown at Fig. 75, an electrically-driven installation is used, the motor driving on to a four-cylinder Reavel compressor, the arrangement of the air-lift pipes in this well, which is 400 feet deep and $7\frac{1}{4}$ inches diameter, being identical to that shown at Fig. 74; a belt-driven plunger pump, used for distributing the water to all parts of the building, completes the equipment. As an example of an air-lift pump being worked by gas power, one at Bembridge, Isle of Wight, may be cited; in this installation a 20 horse-power producer-gas engine, directly coupled to a Reavel compressor, is used for supplying the necessary compressed air for lifting 5,000 gallons per hour a total height of 170 feet, the actual water horse-power, independent of all frictional and other losses, being approximately five, and the cost per hour in anthracite, at 50s. per ton, about 3 pence per hour.

There is very little data available as to the actual cost of pumping on the air-lift principle. A few figures may be, therefore, adduced from a test made by Prof. H. S. Hele-Shaw on an air-lift pumping plant belonging to the Birkenhead Corporation, the machinery consisting of a compound steam-driven two-stage compressor, with steam cylinders 15 and 28 inches diameter, and air cylinders 12 and 24 inches diameter by 30 inches stroke; speed 48 revolutions per minute, and equal to a piston speed of 240 feet per minute. This plant was put down to lift 45,000 gallons per hour, a maximum lift of 300 feet, the water being in this manner delivered to a tank from which it is forced on to a reservoir by a duplex pump; the water horse-power represented by lifting this volume of water to the surface would be approximately 68 for this lift. On test the plant gave results as follows:—Steam indicated horse-power, 156; air indicated horse-power, 135; mechanical efficiency, 86 per cent.; water horse-power, 44, which is equivalent to 28 per cent. of the steam indicated horse-power, and 32 per cent. of the air indicated horse-power; the water in the well remained at slightly less than the 200-foot level throughout the trial.

The following particulars are abstracted from a report of a test made at the Kent Waterworks, on an air-lift pump put down at one of this company's artesian wells:—Diameter of borehole, 24 inches; depth, 250 feet; depth of rising main, 123 feet, alongside which is an air-supply pipe 3 inches diameter; the bottom of the uptake is widened out as shown in the illustration, Fig. 76, at T, into which the air pipe A is bent round so as to project up into the widened mouth at N for a distance of 32 inches, the internal diameter of the uptake at this point being $8\frac{1}{2}$ inches; the water is delivered at W into a tank 4 feet above the surface. The total lift in this case is from 30 to 40 feet, and at the time of the test 34 feet, the quantity of water raised being 156.7 cubic feet per minute, or roughly 1.4 millions of gallons per diem, and represents some 9.6 water horse-power. Now, in obtaining this result, 11.4 cubic feet of free air, or a little over 3 cubic feet of air at 40 lbs. pressure, was used for each cubic foot of water raised, the air being supplied from a direct connected steam-driven double-acting compressor, having a cylinder 14 inches diameter by 16 inches stroke, and running at 100 revolutions per minute. At this speed some 2,800 cubic feet of air would be compressed per minute, and would absorb approximately 24 air horse-power—i.e., at isothermal compression—the efficiency of the pump for water raised to volume and pressure of air used, including air and water pipe resistance, is thus just 40 per cent., with no loss in compression; under the existing circumstances, however, the net efficiency of the water horse-power as compared with the indicated horse-power in the steam cylinder did not exceed 25.5 per cent.

The possibility of raising water on the now recognised air-lift principle was discovered by Carl Emmanuel Loscher, in 1797. No practical application, however, appears to have been made of this discovery until 1866, when an American, named Crockford, took up the idea for raising petroleum from several of the numerous boreholes of Pennsylvania. According to the investigations made by Pohle, a pioneer engineer of considerable experience in the raising of water on the principle explained above, it would appear that there is no advantage in using an air-discharge nozzle, having an annular series of outlets for the purpose of diffusing the air into the surrounding water in a divided state, and in United Kingdom Letters Patent applied for on the 14th January, 1893, and numbered 22372, Pohle claimed special advantage in the discharge of compressed air from a nozzle arranged centrally within a mouthpiece at the bottom of the uptake pipe constructed of a slightly enlarged diameter, this particular method being fairly represented by Fig. 76; Pohle further postulated the theory that air by this means is caused to enter the mouthpiece of the ascension pipe in a series of pulsations, and to be separated in strata from the liquid being

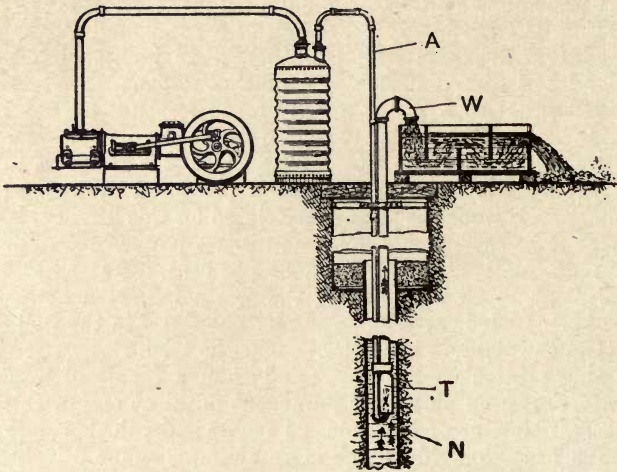

Fig. 76.—Air-lift Pump at the Kent Waterworks.

raised in the form of a number of short columns, the intervals between the liquid widening during its passage upwards by reason of the expansion of the air; this being so, there would be some advantage in continuing the uptake a few feet above the point of discharge to allow the air columns to exhaust on being liberated at the overflow, and in proportioning the lift and air pressure so as to obtain the maximum expansion effect. In any case, it is certain that the action of the air in being forced into an ascension pipe properly submerged, lifts the water by reason of its buoyancy, and is little influenced by the kinetic energy of the air issuing from the nozzle, and may be said to lift more after the manner of an elevator than a pump, any specific difference in effect obtainable by one disposition and form of nozzle over another being entirely demonstrable by using a coloured liquid in a glass ascension tube experimental apparatus, such, for instance, as the Borsig air-lift pump installed at the Machine Laboratory of the Technical High School at Berlin.

Whatever difference of value the respective methods of introducing the air

into the liquid may have, in no way detracts from the importance of properly proportioning the degree of submergence, the diameter of air and water pipes, together with the most suitable pressure and volume of air, in order to obtain the most successful result; in support of this assertion we have only to consider the several variations adopted by different makers of air-lift plant in the method of arranging the submerged parts. The Worthington method, for instance, is to introduce the air by a pipe arranged concentrically within the ascension pipe; while in the Isler, the air pipe is sometimes suspended inside the uptake, and in others the uptake within the air pipe, and yet again, where the diameter of the well permits, to carry the two pipes down side by side. In the Pulsometer and Mather & Platt methods the pipes are arranged side by side; the former, in place of arranging the air pipe so as to project up into the mouth of the ascension pipe, connect the air pipe to a sleeve surrounding the uptake at a point some distance up from the bottom, where it enters and mingles with the water within by means of an annular series of openings. The Thom method is to place the uptake within the air pipe, and the American Well Works *vice versa*. In the A. C. Potter air-lift pumps—*e.g.*, the Skegness Waterworks—the concentric method is adopted. A notable difference is to be found, however, in the disposition and construction of air-lift apparatus on Price's taper-lift system, which is an innovation that possesses several features of interest, and may be said, with some justice, also to more nearly approach finality in respect of economy of working than any other. The taper tube air-lift pump consists of a rising main built up of tubes of a gradually increasing diameter from the intake to the delivery outlet, in connection with which is used a concentrically arranged air-supply pipe, having a discharge nozzle called the "ejector," which is capable of adjustment from the surface—the *tout ensemble* being known as Price's Taper-tube System—the construction of which is shown by the sectional drawing, Fig. 77. In the illustration L is the borehole tube, and T, T¹, and T² the tapering uptake, this being built up of tubes of two or more diameters, according to the depth of the well; the rising main is supported by the head-piece H, in which is formed the delivery outlet D. Over the head-piece is carried a cylinder C, containing a piston P, on to which is suspended the air tube A, this being perforated under the piston to admit the air; the function of the piston or the balance weight B is to assist in the adjustment of the depth of the air tube by the hand-wheel J. Situated about midway between the surface of the water and the air discharge valve V is a second air-outlet nozzle Z, this being opened in starting when the rising main is filled with water up to the level in the well, water meanwhile entering by the perforations in the bottom of the uptake at E. The two air nozzles Z and V are arranged so that only one shall be open at the same time; this is accomplished by allowing the annular seat of the valve V to support the portion of the air pipe between V and Z, thus closing the ring nozzle V and opening the nozzle Z, as shown in the detached sectional view, where the upper portion of the air-supply pipe, represented by A, is shown with a conical plug G, which opens to the rising main on A being lowered. Now, on raising the air pipe A by the wheel J until G closes to the valve box Z, air discharge at this point will be shut off, and by further raising the air pipe A, the section A¹ below Z will be raised, thus lifting the conical valve attached at the bottom, up from the seat carried by the pedestal E; the extent of the annular opening at the air-discharge valve at V is capable of exact adjustment by this means, so enabling the utmost advantage to be obtained from the air discharge at high velocity, and by tapering the tube the upward velocity of the rising column of mixed water and air can be made more constant, the

air being in this manner permitted to expand laterally in place of vertically; this would mean in a rising main, say, of 500 feet in length, and tapering from a diameter of 4 inches to a diameter of $6\frac{3}{4}$ inches, a difference in area at the bottom of the uptake as compared with the delivery end equal to one-half; the velocity of the aerated water flow in delivering 100 gallons per minute would thus be, for a submergence of 200 feet, equal to a volume of water of approximately $16\frac{1}{2}$ cubic feet per minute, plus a volume of air at 100 lbs. per square inch, equal to 11 cubic feet per minute. The combined volume entering the bottom of the rising main would thus be $27\frac{1}{2}$ cubic feet per minute, and would result in a velocity at the bottom or narrow end of about 215 feet per minute, which would in ordinary practice—*i.e.*, with a parallel uptake and expanding

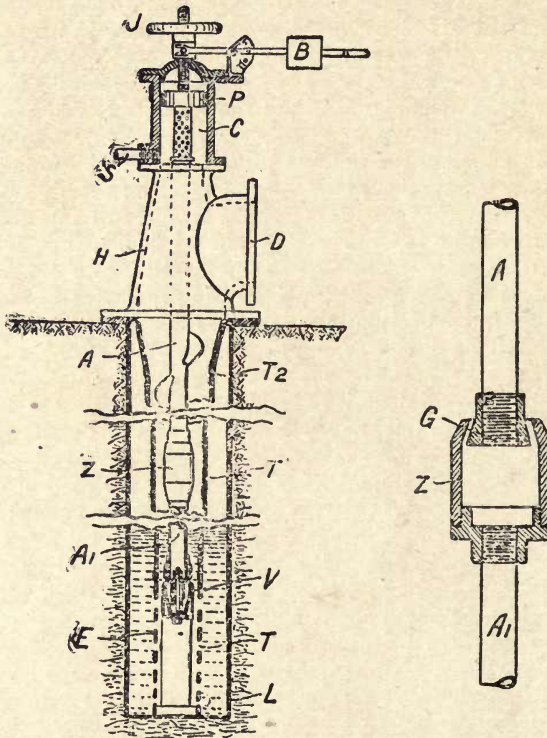

Fig. 77.—Price's Taper Tube Air-lift Pump.

down to $1\frac{1}{2}$ atmospheres (*i.e.*, to about 7 lbs. pressure)—result in an accelerated velocity equal to 790 feet per minute, due to the expansion of the 11 cubic feet of air to 40 cubic feet. Now, in order to obtain the most efficient result the area of the delivery end of the uptake should in this case be 3.7 times larger than the intake end, in order to avoid loss of power by acceleration. The work accumulated in raising the velocity of 100 gallons of water from 215 to 790 feet per minute is approximately 1,600 foot-lbs., which represents less than 1 per cent. of the actual power required to overcome gravitation, and the loss due to acceleration with a 66 per cent. taper is reduced to 0.4 per cent. However negligible this may be, a careful investigation of all the peculiarities pertaining to the

action of compressed air in lifting a column of water, shows results that justify the use of a tapering uptake in combination with an adjustable air admission, judging from the working of an air-lift pump on this system at the Wandsworth and Putney Gas Works, of which the following particulars are abstracted from a report appearing in *Engineering*, September 21st, 1906:—Depth of borehole 630 feet, diameter $7\frac{1}{4}$ inches, the well being lined to a depth of 280 feet below the surface; length of rising main from the ejector to the delivery overflow, 580 feet; height of delivery above the surface, 33 feet; water level while pumping, 223 feet—*i.e.*, 69 feet below rest level, the effective lift being 256 feet, including an allowance of 6 feet for friction in all the pipes. The capacity of the pump, as measured by water raised, was 5,200 gallons per hour, and required 76·5 cubic feet of free air to be supplied per minute, at a pressure of 135 lbs. per square inch—*i.e.*, equivalent to 0·54 lb. pressure per foot of effective lift, and 5·6 cubic feet in volume of free air per cubic foot of water raised; or, in other words, 0·57 cubic foot of air at the ejector was used for each cubic foot of water flowing into the mouth of the uptake per minute. Water horse-power, 7; indicated horse-power of the steam cylinders of the direct-driven two-stage compressor, 19·6; efficiency of plant, 36 per cent.; and thus shows a material advance over results obtained in ordinary practice.

Considering this result, we find that the power lost between the steam cylinders and the air receiver amounts to 8 H.P., and the actual air horse-power as represented by 76·5 cubic feet compressed to 135 lbs. per square inch amounts to 11·5; now, the water horse-power amounts to seven, thus showing that nearly twice as much power is lost in compressing the air as in its application to the actual work of lifting the water, the net efficiency of the compressor and engine being slightly below 60 per cent., and represents an efficiency which is doubtful, and can be materially exceeded in the ordinary two-stage water-jacketed compressor with inter-cooler; if, therefore, the air were compressed at within, say, 50° F. of the free-air temperature, and mechanical as well as air resistance reduced to a practical minimum, the loss then between the steam and air cylinders should not exceed 15 per cent., and the loss between the compressor and the receiver 7 per cent., as represented by diminution of volume after leaving the compressor, 5 per cent. being an ample allowance for valve and pipe resistance. On such a basis the net efficiency between the steam cylinder and the discharge nozzle would be 75 per cent.; and whereas the efficiency of the air in lifting water according to the above figures is 60 per cent.—*i.e.*, from leaving the receiver—it would on this basis, with a compression efficiency of 75 per cent., show a net efficiency for an air-lift pump between the steam, indicated horse-power, and the water horse-power (as represented by the volume of water raised) equivalent to 45 per cent., a result that would increase the usefulness of compressed air in this connection very considerably.

Enough has been said to show that the great impediment to the application of air-lift pumps on a large scale is due to the loss of power in the compressor. This loss, according to generally accepted deductions, is approximately midway between isothermal and adiabatic compression, the error being more generally on the wrong side of the dividing line; for example, the energy required to compress 1 lb. of air to 11 atmospheres—*i.e.*, a pressure very frequently used for air-lift pumps—is 96,000 foot-lbs. for adiabatic compression, 66·4 thousand foot-lbs. for isothermal compression, and as high as 81·6 for the “best cooling” methods in ordinary practice, showing a loss of nearly one-fourth the energy expended on the compressor piston to be due to inefficient cooling. This is obviously unavoidable in the ordinary form of single or double-acting compressor,

however well the cylinder walls, covers, pistons, and interchangers are cooled, as the distance across a compressor cylinder of quite moderate capacity is too great to abstract heat from the air except for an inch or so away from the cooling surface, air being so poor a conductor. Very small cylinders overcome this drawback to a great extent, but absorb more power in mechanical friction and in leakage. From the writer's point of view, in order to compress close down to the constant temperature line, and thus obtain the maximum efficiency, the compression chamber should as nearly approach the form of a condenser as possible; this may not appear feasible at first sight, but is quite practicable by constructing a compressor to work with a hydrostatic cushion at one or both ends of an ordinary water plunger; one form of such a compressor would consist as follows:—At each end of a horizontal cylinder there would be a compression chamber extending upwards, and of a capacity somewhat exceeding the displacement of the plunger piston; this chamber would be divided into a number of cellular spaces by ribs extending across from side to side in both directions; at the head of each compression chamber would be inlet and outlet valves, as used in the best air-pump practice—*i.e.*, rubber disc valves of ample area. In action, the cylinder would be filled with water, which would rise and fall at either or both ends to follow the movement of the plunger, the water being supplied in sufficient quantity to practically avoid clearance, without escaping with the air at the termination of each stroke. In such a compressor all the cooling surface for the air would be water-washed at each stroke, and the compressor piston being water-cushioned, there need not be any air space more distant than 1 or 2 inches from the cooling surface. The cylinder and hydrostatic compression chambers would be water-jacketed in the ordinary way, and the general construction of the working cylinder and plunger in accordance with recognised pump practice. The mechanical efficiency of a compressor constructed on these lines would be approximately identical to that of a good high-lift pump, and the efficiency of compression be within 3 per cent. of the maximum possible, as clearly the air would be compressed under conditions such as to cause heat to be absorbed so rapidly as to enable compressed air to be delivered at practically the temperature of the cooling water. Owing to there being no clearance and no necessity for intercoolers, compression up to at least 20 atmospheres could be effected in one stage, and in this way avoid much loss of working efficiency entailed by gland and piston leakages, and by the additional friction losses involved in the practice of compressing in two stages. Further, with such a compressor, necessity for lubrication—one of the troubles experienced in most compressors—would be obviated; and as an efficiency as high as 75 per cent. has been shown to be possible for the process of compression, and for water raised as high as 45 per cent., it would seem that a compressor constructed on these lines would be worth while, the increased efficiency off-setting the necessary extra cost of construction due to its slowness of action and increased size; for obviously the plunger speed would be limited to prevent splash and consequent escape of water with the air past the delivery valves, thus resulting in loss of power that may exceed the advantage gained by conforming more nearly to the isothermal line.

CHAPTER X.

APPLIANCES FOR RAISING PETROLEUM FROM ARTESIAN OR
BOREHOLE WELLS.

As an increasing proportion of the total output of petroleum oil, now exceeding 50 millions of tons per annum, has to be brought to the surface by mechanical means, a consideration of the various appliances that are adapted for raising oil from deep wells will not be without interest. Further, considering that four-fifths of the oil raised has to be pumped from depths exceeding 200 feet, and at least one-third of this proportion from depths of from 300 to 500 feet down, this process cannot otherwise than be associated with many difficulties. Many wells in Caspasia, Galacia, California, Mexico, Borneo, Burmah, Trinidad, and other fields, are bored to depths ranging from 1,500 to 2,500 feet and more, from which oil, intermixed often with a considerable proportion of brine, has to be frequently raised from the 600-foot, and in some cases from the 1,000-foot level.

The appliances that have been pressed into this service, as will be gathered below, present some extremely varied and interesting characteristics, the principal of which consist of:—(1) Special adaptations of the ordinary plunger force pump; (2) an appliance known as the baler pump; (3) the compressed air displacement pump; (4) the air-lift pump; and (5) an appliance that may be termed a conveyor pump or elevator. Of these several appliances for raising petroleum, the first named is more suitable for comparatively shallow wells, although used for deep wells when sand is not present. The common practice in the Pennsylvanian and other oil fields, where wells have not to be bored to greater depths than 300 feet or so, is to link up a series of pumps so that a number of wells can be worked from a common power-house by means of suitably supported tension rods, and presents a practical means for separating the boiler-house some distance from the wells—a consideration of some importance when steam power is used. Plunger pumps employed for this purpose seldom exceed a diameter of 6 inches, but pumps from 3 to 4 inches are the sizes most commonly used; these are generally single acting, and fitted with spherical or ball valves on account of difficulty with the sand encountered, the ball valve being less liable to stick up than any valve requiring a guide stem. The apparatus shown in Fig. 78 serves as well as any other to illustrate the kind of actuating gear adopted for linking up a series of small plunger pumps, this, as will be seen, consists of a vertical gear-driven shaft, on which are keyed a series of large eccentrics (*x*), from the strap surrounding each of which are connected a series of rods, wires, or ropes to the various wells, where the horizontal motion is changed to a vertical one by an ordinary crank lever. A flexible steel wire as at (*e*) is the form of connection most suitable for wells at such a distance as to require guide pulleys, although for shorter distances an iron wire such as (*r*) or wood strut as at (*d*) is commonly used, these for distances not exceeding 500 feet or so being supported on rocker arms.

The appliance used for raising petroleum from the deep wells of the Baku district, where the strata bored through is of a peculiarly sandy nature, is known as a baler pump or "jelonga," and is a development of an early form of pump used for water wells. The baler, as now used for raising oil, ranges in size from 6 to 18 inches diameter, and from 15 feet to 40 feet long, and is suspended by a wire rope (from $\frac{3}{8}$ to $\frac{7}{8}$ inch diameter, according to size of bucket) from a pulley as at (e), Fig. 79, carried by a derrick (k) built to a height to enable the "jelonga" (b) to be emptied into a tank (p) or race alongside. In consequence of the extreme length of these buckets (from 30 to 40 diameters) the height to which the derricks are carried is often found to exceed 60 feet and higher, and forms, in consequence, quite a characteristic feature of many oil fields. The power required to work a baler pump 10 inches diameter by 20 feet long, and weighing 520 lbs. empty and 1,200 lbs. full, is from 38 to 40 I.H.P., there being naturally

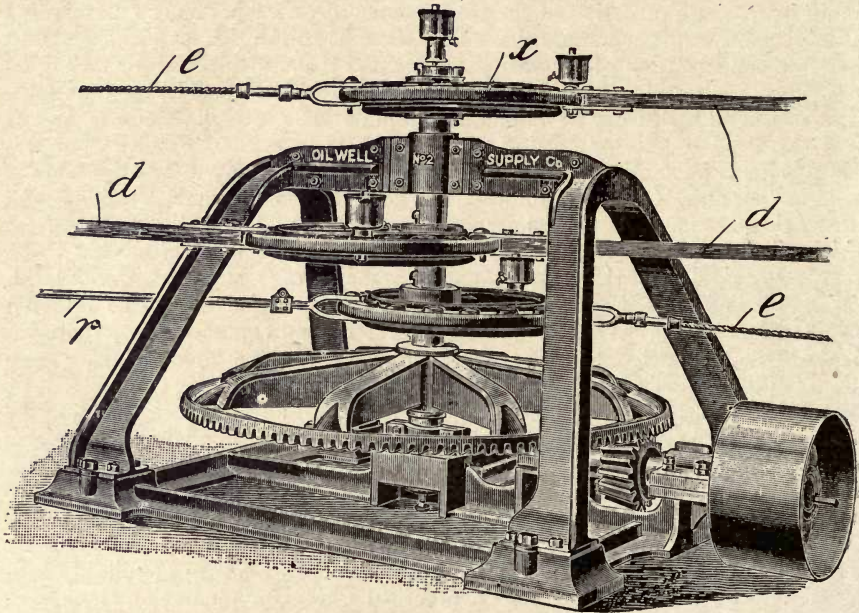

Fig. 78.—Multiple Plunger Pump actuating Gear for Oil Wells.

no means for utilising the power lost in the lowering process. With a baler of this size, 1,000 lbs. of oil-well liquid consisting of brine, sand, and petroleum can be raised per minute from a depth of 510 feet (the bucket being lowered to a depth of 1,100 feet at alternate dips) on a consumption of 240 lbs. of astatki per hour, and will, therefore, be seen to average 6 lbs. per I.H.P. per hour.

Although a baler pump can be operated at such high speeds as 700 to 1,000 feet per minute, the output is considerably limited owing to its intermittent action, and as in ordinary practice the bucket is lowered several hundred feet below the level of the liquid at every third or fourth dip for the purpose of preventing the bottom of the well from silting-up, the greatest number of dips seldom exceeds from 20 to 30 per hour. In action a tremendous agitation is set up in the well if precaution is not taken to slacken the speed on striking the oil column, which agitation is considered by many authorities to have a detrimental

effect on the natural inflow of oil to the well—a conjecture that is fully substantiated by the greater output of oil from wells operated by a continuous system of pumping, as by air-lift and elevator pumps. Another disadvantage associated with the operation of a baler pump is the unremitting attention demanded on

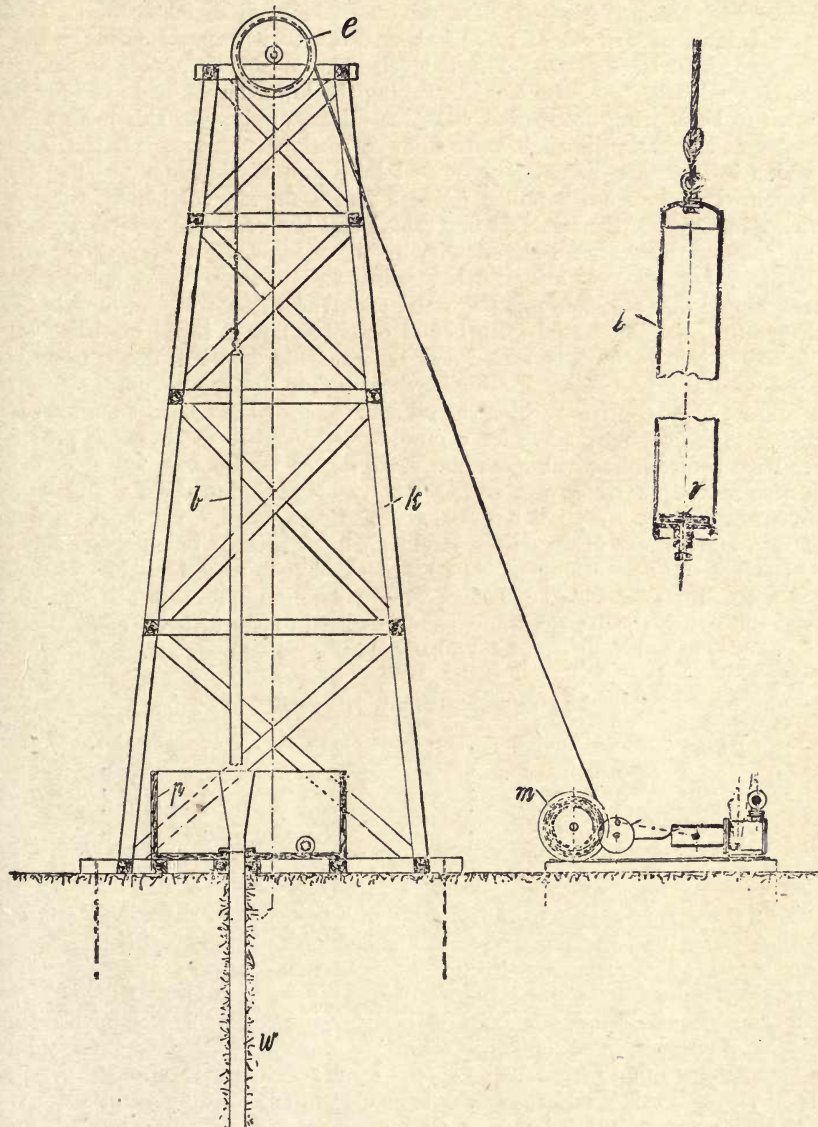

Fig. 79.—Derrick and Winding Gear for Baler Pump.

the part of the operator in charge of the winding engine; there is, moreover, a considerable wear and tear of the cable to be allowed for, as well as damage done to the bucket in contacting with the casing used to line the borehole,

this latter defect being more particularly in evidence with wells bored out of p'umb.

The construction and manner of working an oil-raising plant operated on the baler system will be gathered from the illustrations, Figs. 79 and 80. In this example, the borehole (*w*) of a minimum internal diameter of 12 inches is carried down to a depth of 1,500 feet, and lined with a steel casing down to somewhere about the 800 to 1,000-foot level. The casing is increased in diameter at the upper levels for convenience in tubing the lower levels, as in the practice followed in the boring of artesian wells for water supply. In this instance the diameter of the casing is such as to allow a working clearance for the bucket (*b*) which is 10 inches diameter by 34 feet long, and suspended by a steel cable of $\frac{5}{8}$ inch diameter from a pulley (*e*) of 5 feet diameter, carried by the wood derrick structure (*k*), the bucket being raised and lowered from a winding engine (*m*), which may be actuated electrically, by oil, or by steam power, as shown.

In general practice the bucket is lowered down into the well at a speed closely approaching 1,000 feet per minute, until near the surface of the liquid. The bucket, after being immersed for a few seconds to allow it to fill from the valve (*v*), is then again as quickly raised and the contents emptied into a tank, this method naturally necessitating a higher derrick; or, the bucket can be emptied into a sluice as at (*p*), from which the oil runs by gravitation, or is pumped into a storage tank that may serve for a number of wells. The bucket is provided either with a disc filling valve, as shown at (*v*), or with a ball valve, or again with a spherically seated valve with a stem projecting downwards, and known as an arrow valve; a flap valve is also sometimes fitted. The bucket, which is of thin steel, must always be from $1\frac{1}{2}$ to 3 inches less in outside diameter than the bore of the casing at its narrowest diameter, and can be operated under normally favourable conditions with a winding efficiency of from 50 to 60 per cent., when the net efficiency, as represented by the difference of indicated power and oil raised, falls somewhere between 25 and 30 per cent.

Particulars of Baler Pump (10 inches \times 34 feet).

Weight of bucket empty,	350 lbs.
„ contents,	1,100 „
„ cable,	220 „
Total weight to be lifted,	1,670 „
No. of dips per hour,	25
Power required to lift baler empty,	20 H.P.
„ „ charged,	60 „

It will thus be seen that in the working of a baler pump there is an approximate loss of from 30 to 35 per cent. in lifting the dead-weight of the cable and bucket at each dip. The average power required to operate a number of baler pumps electrically from a central power-house ranges from 26 to 30 E.H.P. per pump, capable of raising a volume of liquid representing 9 P.H.P. The net efficiency, therefore, obtainable in operating a series of baler pumps under these conditions ranges from 29 to 33 per cent.; as between the power represented by the oil raised and the power expended at the winding drums.

Of the two methods for raising oil by compressed air—viz., by direct air pressure or displacement, and by elevator or buoyancy action, the first named is now not much used, as its operation not only entails a more expensive construction, but a less efficient action than the air-lift or aëration method. The action of a direct air-pressure pump is intermittent, and is usually controlled by hand, but can be constructed to work automatically as shown below. The

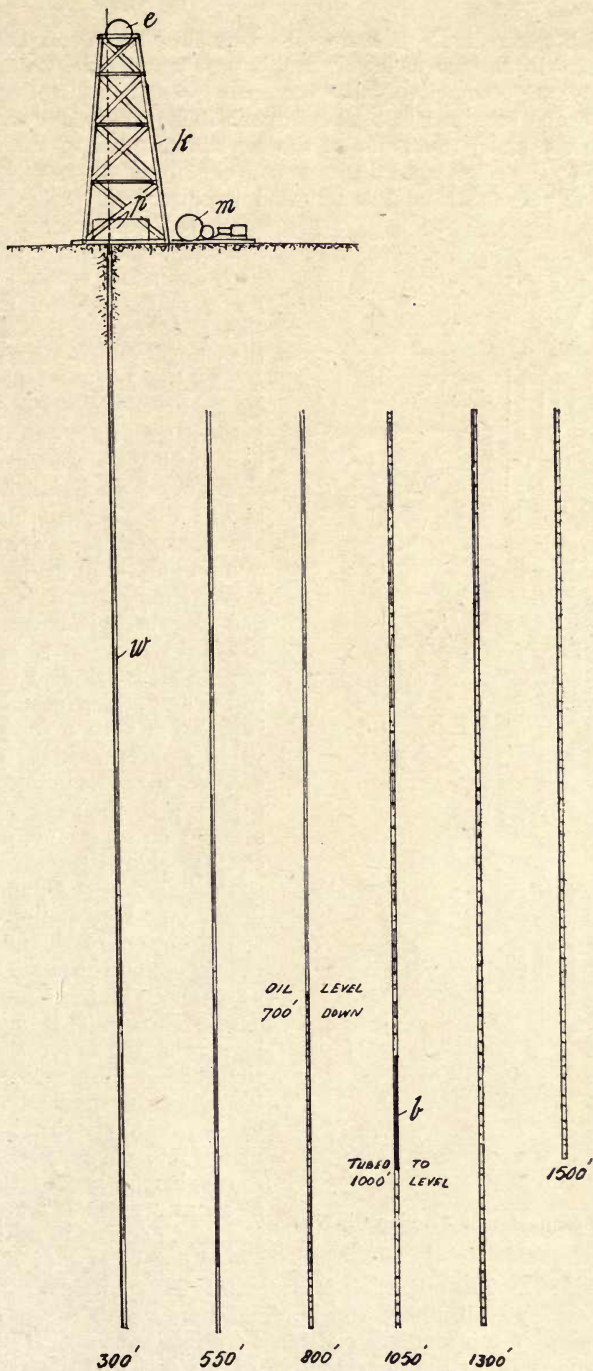

Fig. 80.—Section of Oil Well with Baler Pump.

speed at which a direct air-pressure oil-raising appliance can be operated is determined more by the size of the air supply pipe than by the pressure at which the air is delivered, as obviously the principal factor in control of the rate of output is the time occupied in recharging the filling chamber, which is determined by the combined resistance of the air exhaust and of the inflow of oil from the well to the submerged displacement chamber.

Although displacement pumps actuated by direct air pressure have been

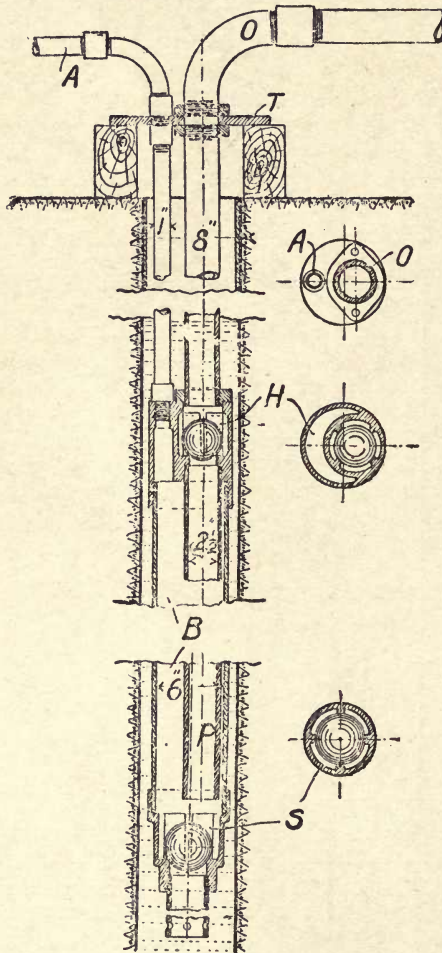

Fig. 81.—Air-displacement Artesian Oil-Well Pump.

employed for raising petroleum from artesian wells, their working has met with indifferent success, their failure being more due to the excessive clearance space between the filling tube and the air-distributing valve mechanism at the surface level than to any other cause, the consumption even with an early cut-off being very high, owing to the impossibility of arranging the admission valve close to the displacement chamber. An air-displacement artesian oil-well pump of the kind that has been used in Austria, Bavaria, South Russia, and elsewhere, is illustrated at Fig. 81. In this construction the compressed air is supplied by the pipe A to the long filling chamber B, which is provided with a spherical suction valve S arranged in a guide cap screwed over the bottom end of the tube B; at the top a second cap is screwed on containing a smaller discharge valve H communicating with the delivery pipe D, and having an intake pipe P extending down nearly to the bottom of the filling chamber B. In action the pump is suspended by the uptake from a plate T, at a depth at which B will be quite immersed, the lower the immersion the quicker the chamber B is filled, for which purpose the pipe A is either automatically or by hand placed into communication with the atmosphere, when by the admission of air at a pressure corresponding to the depth of B the contents can be forced out by way of P past H into

the delivery pipe D. The operation is necessarily slow owing to the restricted areas of the air and oil pipes, which when operating at a great depth, say 400 feet, impose a considerable resistance; this, however, is of negligible importance compared to the consumption of air due to the clearance in the supply pipe; for instance, with a filling tube 6 inches inside diameter by 16 feet

long, its capacity minus the displacement of P is 3,700 cubic inches, and the clearance in A 2,800 cubic inches, thus requiring at this lift 1 cubic foot of air delivered at 220 lbs. per square inch for each 5 gallons raised, as against 0.6 cubic foot for a like output on the air-lift principle. The displacement pump, *per contra*, does not depend on a submergence much exceeding the length of the filling tube.

An application of this principle arranged with a modified form of distributing mechanism of Hungarian origin for the purpose of automatically admitting and exhausting compressed air to obtain continuous working of an artesian well displacement pump is clearly illustrated by the sectional, elevation, and

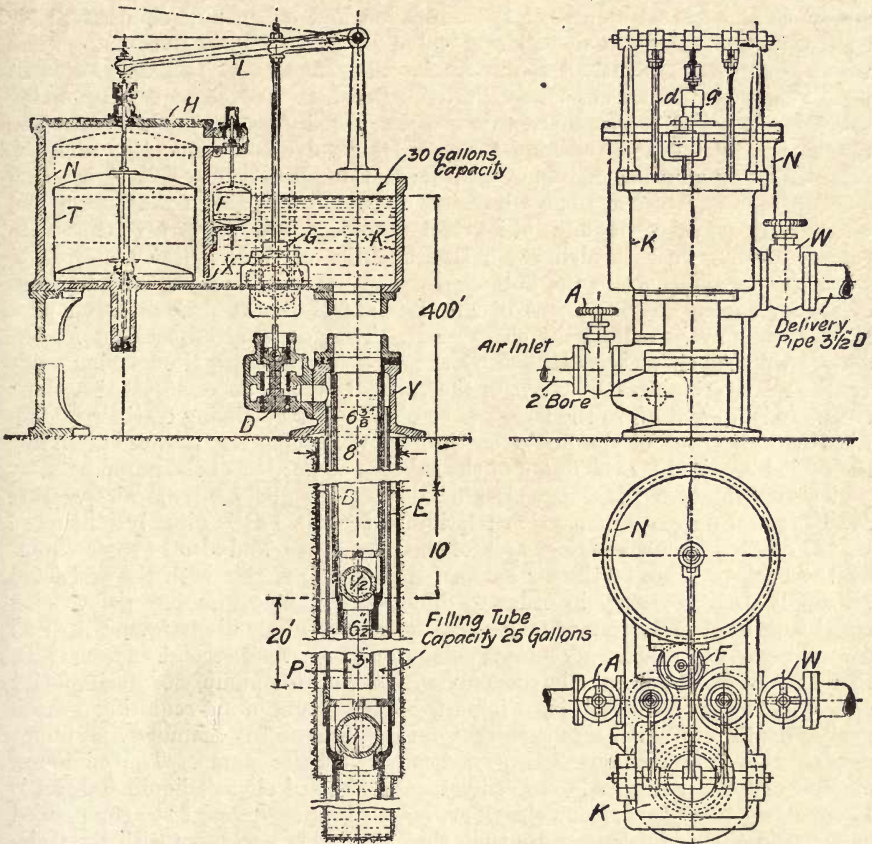

Fig. 82.—Air-displacement Borehole Pump with Automatic Float Distributor.

plan views at Fig. 82, automatic action in this case being obtained by the action of a cistern of about the capacity of the pump-filling tube, which is provided with an air-tight chamber placed in communication with the contents of the cistern from time to time, the liquid being prevented from entering by the entrapped air until the level in the cistern has attained to a certain predetermined point, when a small float opens a ventilator valve—or an ordinary ball-cock may be used—which allows the entrapped air to escape and liquid to enter from the adjacent cistern. This action causes a large float contained in the

air chamber to lift and ordinarily to actuate a 3-way cock controlling the admission and exhaust of air to the submerged filling tube, as well as to open and close a valve for emptying the cistern.

In this automatically operated displacement pump, a filling tube E of a diameter of 8 inches is suspended from the ankle casting Y to a depth of 400 feet, the tube being provided at the bottom with a socket and suction valve cap V_1 ; and within this outer tube is suspended an uptake tube B to within such distance from the suction valve as required to constitute the filling chamber. At the bottom of this inner tube is screwed on a cap containing the delivery valve V_2 , from which depends, as in Fig. 81, a pipe P, the slight clearance between B and E serving as a conduit for the admission and exhaust of compressed air controlled by the piston distributing valve D. The uptake B communicates with a cistern K of slightly greater capacity than the filling chamber. Adjacent to this cistern is the air chamber N, provided with an air-tight cover H, passing through which is a rod attached to a metal or wood float T, which is caused to rise on the pilot float F opening the ventilator valve communicating with the top of N, thus allowing ingress of oil from K through X. The float T in rising cuts off at an early stage the admission of compressed air to the pump, and on reaching nearly to the limit of its stroke upwards causes the valve G to open communication with the delivery outlet, and the valve D to the atmosphere, when the float T sinks to the bottom and traverses D down for the admission of air for another displacement of the contents of E, the float-actuated pilot F meanwhile again sealing the chamber N. The necessary adjustment for the desired working speed is controlled by the air stop valve A and emptying valve W, the relative positions endways of the valves D and G being adjusted by nuts on the rods (*d*) and (*g*) to the levers L to obtain correct timing of their motion with the movement of the float, the throttle W serving the purpose of timing the period required for the filling of the submerged portion of the pump.

The output of a pump of this kind depends not only on the air pressure available and degree of expansion relative to the lift, but is directly influenced by the depth of immersion and area of the inlet valve, and also to some extent by the back pressure of the air exhaust during filling, this with the restricted air-supply area necessary in order to diminish clearance to a fine point being equal to a head of 10 feet or more, with a velocity of air discharge for a speed of working of two strokes per minute being some 20 feet per second. The system, therefore, does not compare in economy with the air-lift pump, nor in simplicity either, its only advantages of any importance consisting in not requiring a much greater depth of submergence than that of the displacement chamber, and in not causing the excessive agitation as set up by a baler pump. The minimum amount of free air required for raising 1 cubic foot of oil-well liquid 400 feet is 15 cubic feet to 17 cubic feet; this, however, although required to be compressed at a considerably higher pressure than that absolutely necessary with the "air-lift," yet does not exceed the pressure percentage to "lift" often employed in raising petroleum from deep wells on the aëration principle.

The direct air-pressure principle compares to less and less advantage the lower the level from which the liquid is to be raised; for instance, to pump from a depth of 700 feet would require an air pressure of 375 lbs. per square inch, and the consumption of air at this pressure would be approximately 12 cubic feet per minute, at a speed of working equal to 40 discharges per hour; or, in other words, 1.7 cubic feet of air at 375 lbs. pressure would be expended for each cubic foot of liquid raised, and as the power absorbed in compressing 300 cubic feet of free air per minute (the volume required to raise 12 tons of oil liquid from

a depth of 700 feet) to this pressure, will not be much less than and may be more than 80 H.P., the net power efficiency of a pump working on this system cannot very well be higher than from 11 to 12 per cent. in delivering against this head. In common fairness to this method of raising petroleum or other liquids, it should be stated that this low efficiency will improve in proportion as the depth of lift is diminished by reason of reduced clearance loss in the shortened air-supply pipe—*i.e.*, provided the well be free from sand, for otherwise leakage past the filling valve would make this type of pump impossible for any lift.

Compressed air can be used to much better advantage when applied on the aëration principle, as in this form of pump no submerged mechanism is needed, the lifting power as applied to the raising of liquids on this method being due to the aëration of an ascending column, hence the title "air-lift." In this pump the only parts required in the well are two pipes, one for the supply of compressed air, and one for the uptake, both of which are submerged to a depth in the liquid equalling about half its level below the point of delivery. There are several ways of arranging these pipes, as before pointed out, but the usual practice for deep wells of comparatively small diameter, such as used for raising oil, is to subtend the air pipe within the ascension pipe, as shown at (*d*) and (*n*) in the illustration (Fig. 83). The end of the air pipe usually terminates in a rose, as shown at (*f*), and is provided with a series of outlets having preferably an upward direction, although not necessarily so. Around the nozzle, and for a considerable depth below, the ascension pipe is extended downwards as shown at (*x*), the pipe at this point being of a slightly increased diameter, so as to oppose as little interference as possible to the entrapping of the liquid. The ascension pipe is carried by an anklet casting provided with a packed gland (*g*) for receiving the air downtake pipe (*d*), a construction that lends itself for raising and lowering the nozzle in order to obtain a submergence best adapted for the oil level.

The air nozzle is usually subtended to a distance from the point of delivery, equal to from 60 to 70 per cent. greater than the total lift—*i.e.*, the distance from the oil level, as shown at (*v*), to the discharge outlet (*p*). Thus, in order to raise oil from the 700-foot level as at (*v*), the depth of submergence of the air pipe must be approximately 500 feet. The ascension pipe is proportioned to an absolute minimum in diameter, owing to its great length, and in a pump having a capacity of 12 tons of oil per hour from the 700-foot level; the bore of the outer pipe is $4\frac{1}{2}$ inches, and that of the inner pipe $2\frac{1}{2}$ inches, which is the limit of size in order that the velocity of the air column may not exceed 50 feet per second. The volume of air discharged at the nozzle to raise 7 cubic feet, or 40 lbs. of liquid per minute, is in good practice about 8 cubic feet per minute at 300 lbs. pressure, which is the equivalent of 0.6 lb. pressure for each foot of submergence, and is thus seen to compare very favourably with the volume of 12 cubic feet at 375 lbs. pressure, as required to raise an equivalent weight of liquid by a pump operated on the direct air-pressure displacement method.

The cost of an air-lift installation is approximately the same as that of a baler pump, when taking into consideration the derrick, and only two-thirds that of a displacement pump; but its principal advantage is its continuous action, and in requiring no operating valve or mechanism either in the well, or at the surface, which, together with the other advantages named, constitute features of value which outweigh its dependency on such deeply submerged pipes, and to the fact that by an air-lift a deep well cannot be pumped to within several hundred feet of its lowest level. For instance, on the property of the Russian Petroleum and Liquid-Fuel Company, at Bibi-Eibat, where some 15 compressors of a combined capacity equal to the compression of 4,500 cubic

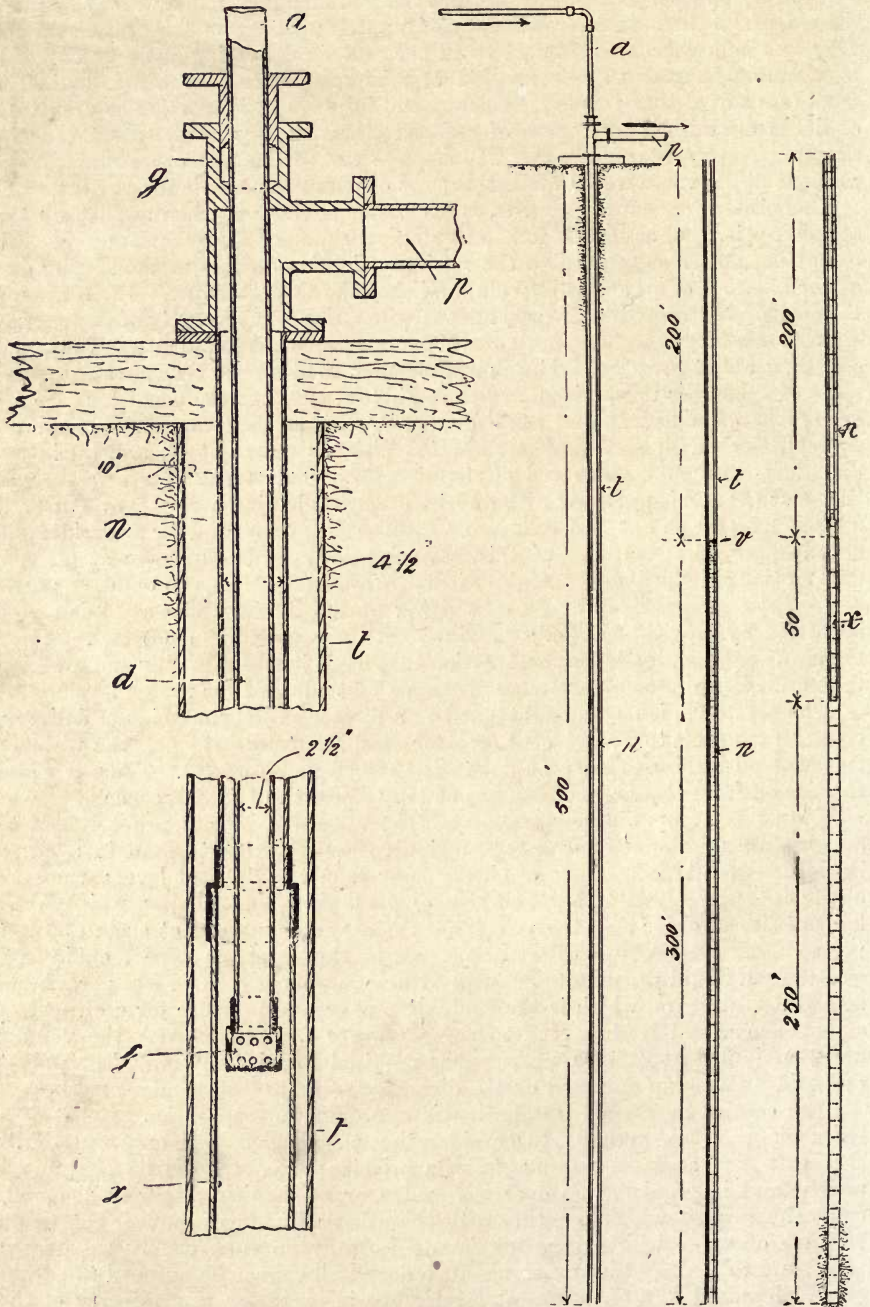

Fig. 83.—Arrangement of Air-lift Pump for 1,500 Feet Well with Oil at the 700 Feet Level.

feet of free air per minute, to pressures varying from 200 to 300 lbs. per square inch. have been installed, the raising of oil on this principle has been of peculiar value, as a great quantity of sand, saline, and other solids are brought to the surface with the petroleum, from which cause the use of deep-level plunger pumps is next to impossible; and the use also of a baler very unsuitable owing to the curvature of many of the wells, which would necessitate the use of balers constructed in halves and articulated so as to avoid being strained in rising and falling by a certain degree of flexure; balers constructed of flexible metallic tubing have been used in some bad cases where the curvature is unusually pronounced.

As oil wells in this district vary in depth from 1,000 to 2,000 feet, they present many possibilities for wear and tear, not only on account of their want of straightness, but owing also to overwinding of the baler drums, it not being unknown for a bucket to be shot right over the drum, and, needless to say, hopelessly smashed. Air-lift pumps, although presenting a most convenient alternative for raising petroleum, having been, as before pointed out, first used for this purpose, are not by any means as economical in power as the baling process. Take, for instance, a well having pipes extending down to 1,540 feet, the ascension pipe of 4 inches internal diameter containing a $2\frac{1}{2}$ -inches diameter air-supply pipe, which is continued down to within 70 feet of the end of the uptake, which, by-the-way, is carried down to within a few feet of the bottom of the well, in order to prevent silting up, and to obtain the maximum degree of submergence, which in this case is 47 per cent. of the actual lift of 770 feet, this requiring an air pressure of 300 lbs. per square inch, supplied by a two-stage compressor, having cylinders 7 and 14 inches diameter by a stroke of 12 inches, and run at 75 revolutions per minute, at which speed the volume of free air compressed is 150 cubic feet per minute. The volume of compressed air discharged into the well at a pressure of 20 atmospheres is 7.5 cubic feet per minute, and the volume of petroleum raised per minute 6.25 cubic feet, which is equal to a weight of 396 lbs.—*i.e.*, approximately in degree of density to that of salt water. Now this represents an actual gravitation or petroleum horse-power of 9.25 and shows an efficiency of 25 per cent., the indicated horse-power of the compound direct connected steam cylinders being 36.

In another instance, with pipes and a well of the same diameter, but having a submergence of only 37 per cent., and a direct lift of 650 feet, 5.5 cubic feet of petroleum on these conditions is raised per minute by an air pressure of 350 lbs. per square inch, the actual gravitation horse-power being seven; however, in this case, a greater percentage of air is required, as would be expected, owing to the reduced ratio of submergence, and results in a net efficiency of only 15 per cent., and thus shows in a marked degree one of the influences in the working of a pump on the air-lift principle. As previously indicated, the most economical results are obtained with a submergence of from 55 to 65 per cent. of the total lift in the rising main—*i.e.*, the distance between the level at which the liquid leaves the uptake and that at which the air is discharged in the well—any increased depth beyond this necessitating a proportionate increase of air pressure, which, with a compressor of ordinary efficiency of 50 or even 65 per cent., will absorb more power than that gained by additional submergence—*i.e.*, the resulting lifting power, if any, thus obtained, will be more than counterbalanced by the decreasing ratio of efficiency of the compressing plant—then, again, the effect of reducing the ratio of submergence will result in an increased volume of free air being supplied at reduced pressure. In the case of the oil wall air-lift pump referred to, working with a submergence of 47 per cent., the

volume of free air is 24 cubic feet for each cubic foot of petroleum raised, the lift being 770 feet, and the pressure 300 lbs.; but in the other case, having a 37 per cent. submergence and a lift of 650 feet, the volume of free air required per each cubic foot of petroleum raised is increased to 40 cubic feet, the pressure being reduced in this case to 170 lbs. per square inch. In order to emphasise the effect of arranging for the air discharge to be too near the surface of the liquid in the well, it may be borne in mind that it is even possible to elevate a liquid by compressed air with a submergence of just sufficient depth to cover properly the discharge nozzle, but at a great expenditure in air, the liquid in this extreme case would obviously be lifted in the form of spray.

Other useful data bearing on the application of the air-lift pump for raising oil from deep levels are as follows:—

Depth of well,	1,540 feet.
Oil level beneath the surface,	770 "
Submergence of air nozzle,	540 "
Ascension pipe continued down to	1,500 feet.
Diameter ascension pipe,	4 inches.
Diameter compressed air pipe,	2½ "
Air pressure per square inch,	300 lbs.
Volume discharged at nozzle per minute,	7.5 cubic feet.
Volume petroleum raised per minute,	6.25 "
Weight petroleum raised per minute,	396 lbs.
Actual petroleum or P.H.P.,	9.25
Indicated H.P. in steam cylinders,	36
Net efficiency,	25 per cent.
Another instance is as the following:—	
Depth of well,	1,500 feet.
Direct lift,	650 "
Submergence,	455 "
Air pressure per square inch,	350 lbs.
Petroleum raised per minute,	5.5 cubic feet.
Net efficiency per cent.,	15
Again—	
Two-stage compressor (cylinders 14" × 7" × 12"), revolutions per minute,	145
Volume of free air per minute in cubic feet,	300
Compressed to lbs. per square inch,	270
Indicated H.P. of steam cylinders,	70
Petroleum H.P.,	15.4
Petroleum raised per minute in lbs.,	1,000
Petroleum raised from depth in feet,	510
Net efficiency per cent.,	22
And again with a two-stage compressor—	
Volume discharged at nozzle per minute,	8 cubic feet.
Volume petroleum raised per minute,	7 "
Weight petroleum raised per minute,	440 lbs.
Oil level in well,	700 feet.
Depth submergence,	500 "
Actual pump H.P.,	9
Indicated H.P. in steam cylinders,	45
Net efficiency,	20 per cent.

The following volumes of free air in cubic feet are average requirements for each cubic foot of oil raised from a depth of 500 feet:—

With a submergence of 70 per cent.,	11
" " 60 "	12
" " 50 "	15
" " 40 "	25

Again, to lift 1 cubic foot of oil 600 feet, with 66 per cent. submergence, requires 15 volumes free air at 175 lbs. per square inch. To lift 1 cubic foot of oil 850 feet, with 43.5 per cent. submergence, requires 35 volumes free air at 165 lbs. per square inch.

N.B.—Petroleum as obtained from the above records averages about 66 lbs. per cubic foot.

In order to overcome the disability under which all oil-raising appliances operated on the air-lift principle have to work—viz., “the deep submergence of the uptake pipe, so making it impossible for a well carried down to the 1,500 ft. level, for instance, to be pumped to a lower level than 1,000 feet, thus leaving a depth of 500 feet of oil in the well, from which cause oil is naturally obstructed from flowing into the well from hydrostatic pressure, and the well, therefore, prevented from being worked to its full capacity”—several appliances have been devised to raise oil on the conveyor principle. The essential feature in the conveyor or elevator pump is the employment of an endless band, one loop of which depends into the well with a few feet of submergence, and the other is arranged to run through a pair of rollers to squeeze the oil adhering to the band into a collecting vat, sluice, or tank. The velocity at which a band may be driven depends upon the viscosity of the oil; in the Pedley oil elevator, a steel band 3 inches wide by $\frac{1}{16}$ inch thick has been used for a well 500 feet deep in California, in which the oil to be raised is rich in paraffin and comparatively thin in consistency; the output, therefore, was found to be less than would be expected with a thicker oil. In the Pedley endless steel band elevator, the oil is scraped off by a sort of spoon, the band simply running over a flanged driving pulley, and kept taut by a weight suspended in the well from a small runner. The band when driven at a velocity of 20 feet per second was found to raise about 30 lbs. of oil per minute, and to require only about 1 E.H.P. to drive it, thus demonstrating that oil can be raised in this manner with a very high efficiency.

In the Leinweber elevator pump, several of which are used by the Galician-Carpathian Petroleum Company in the Kryg oil fields, a hemp band is used, on to which is attached a number of loose strands of “carpet-shag,” in order to increase the adhering capacity. A band of this construction is naturally limited to a slow speed, but is found to have a high lifting capacity, as much as 2 lbs. per metre being raised at a speed of 1 metre per second, with a band 3.25 inches wide by 0.37 inch thick, from a well 9 inches diameter and 1,500 feet deep, and having only 50 feet depth of oil, under which circumstances it would obviously be impossible to use an air-lift pump, and very difficult indeed for either a baler or plunger pump to be worked with any show of success. It is noteworthy that these belts, although three-fifths of a mile long, are made in three lengths, and are sewn together at “well-head” by cobblers’ thread and a saddler’s sewing machine, such a band having a breaking strength of 4 tons, and in fact has to carry a surcharge load of 3,000 lbs. on the ascending side.

The method employed for driving and pressing the oil from the band is illustrated diagrammatically by Fig. 84, in which the band represented by (*p*) first passes over a pulley (*e*), the ascending charged side then passing through a pair of rollers (*r*) situated over the oil collecting vat (*y*), the band thence passes twice over the two driving pulleys (*m*, *m'*), which are geared together, the squeezed end then returns down the well after passing over the pulley (*e'*). The complete apparatus is of necessity strongly made, but has the advantage of being quickly set to work, the splicing of the band and lowering into position not requiring more than a few hours.

A self-contained band conveyor pump, electrically driven and of substantial construction, has been designed by the writer for use in deep wells in which the oil only rises at most to a hundred feet, so precluding the use of an air-lift, or in some cases even a baler pump. In this pump, of which the illustrations, Fig. 85, are reproduced from working drawings, an endless two-ply gandy belt (t) is suspended over the well by an A frame structure carrying two pulleys (a, a^1); the ascending end of the belt thence passes in the direction of the arrows over a roller (r^1), on to which it is pressed by the roller (r^2), the oil thus squeezed from the belt falls into the cistern (n), whence it can be drawn off at the outlet (p). The descending end of the belt after leaving the roller r^1 passes over the guide pulley (r), and thence over the pulley (a^1) to the well, where at the loop it is held taut and centrally with the well casing by a suspended weight (w).

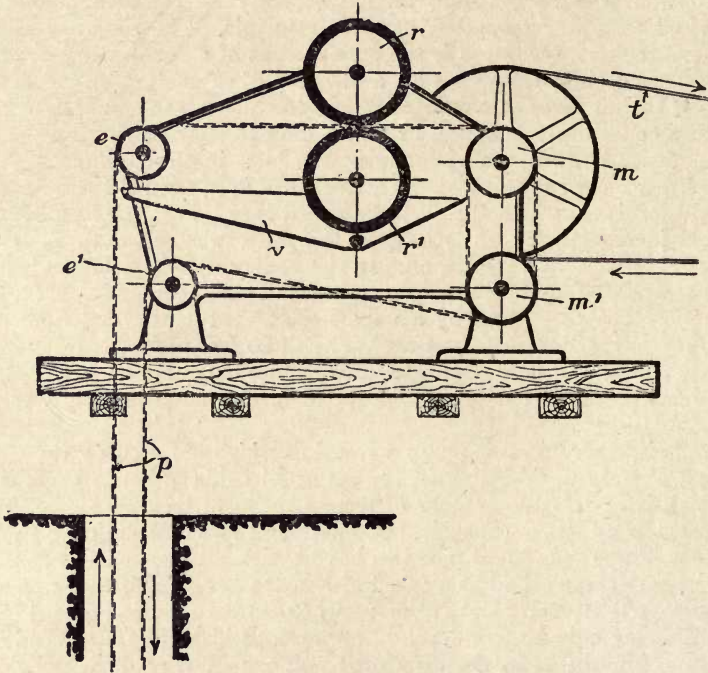

Fig. 84.—Leinweber Endless Band Pump for Raising Oil.

The guide pulley (r) and roller (r^1) are carried in bearings (b) capable of being moved along the supporting frame by set-screws (e), by which means the required pressure can be obtained between the rollers (r^1) and (r^2). The driving power is derived from a 20 H.P. electric motor (m) running at 900 revolutions per minute, the driving roller (r^1) being reduced in speed by the intervening gear wheels to 100 revolutions per minute, from which the speed of the gathering belt is approximately 450 feet per minute, but can be varied from 350 to 600 feet per minute. At the mean working speed a belt without any collecting attachments and 4.5 inches wide is capable of raising from 5 to 7 cubic feet of thick oil per minute from a level 1,000 feet down, and the only submergence required is about 10 to 20 feet, and, moreover, with less expenditure in power than by any other form of deep level pump; as the friction is very much less in the

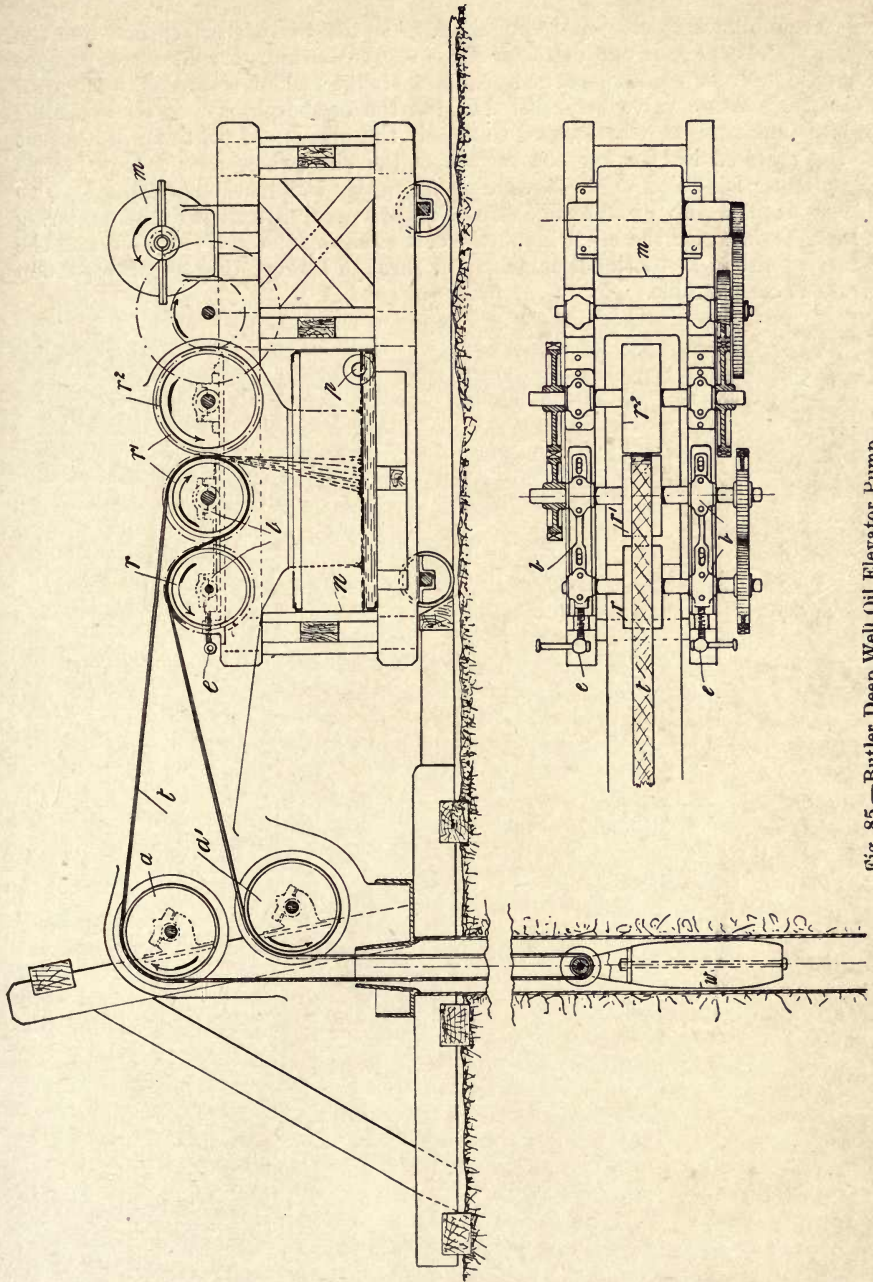

Fig. 85.—Butler Deep Well Oil Elevator Pump.

belt ascension than in a pipe, the more viscous the oil the greater the advantage of the belt lift.

There is yet another method of raising oil from deep wells, in which the liquid

only accumulates to comparatively shallow depths, and that is to first line the well with a casing of one diameter from top to bottom, the lifting apparatus consisting of a cup-leather-packed piston or plunger, which is lowered by its own weight, a snifting valve being fitted in the top of the plunger to allow the air to escape during its descent, and to enable the plunger to continue its descent to the required level below the surface of the oil; when after a few seconds the plunger is hauled up by a winding drum, by this method a column 50 to 80 feet deep can be raised at one stroke, and has the advantage of not requiring a high derrick. On the other hand, the cost of casing the well is higher, and the power absorbed in frictional contact and through leakage during the ascension stroke is considerable.

CHAPTER XI.

BOILER-FEED AND GENERAL SERVICE PLUNGER PUMPS,

THIS all-important application of pumping machinery embraces in some degree almost every form of direct-acting and power-driven pump, the endeavour of makers being for the most part to supply an article which shall be essentially reliable and automatic in action; the demand for this auxiliary when used for marine purposes tending more especially in this direction than when employed for power stations, in which instance economy is found to be the first consideration. Pumps of this character are made in several types, but may be generally classified as follows:—Direct-acting simplex and duplex pumps, flywheel pumps, and gear or belt driven pumps: the two direct-acting types being equally adaptable to the vertical and to the horizontal form of construction.

In recent years there has been a notable tendency for many makers to adopt the direct-acting simplex or marine type of pump for boiler-feed purposes, in the construction of which the principal differentiation applies to the steam end, this being in almost all cases provided with a combined mechanically-actuated and steam-thrown distributing valve of variously modified form, in which connection there are, as will be seen by the following examples, some most interesting and ingeniously planned “gears,” the solution of this problem evidently not being quite the simple nature as appearing at first sight, as pumps used for this purpose are required to be capable of continuous action under all sorts of working conditions for many days together, and withal be self-regulating and, what is of the utmost importance, be positively proof against sticking-up. Provided these conditions be fulfilled, the direct-acting simplex form of feed pumps present in a high degree such advantages as the following:—

(1) Economy in space occupied; (2) can be made with less steam port area than the duplex pump, and be run slower than the flywheel or geared pump; (3) the simplex form lends itself conveniently to being compounded for use with high pressures; (4) when used in pairs, the two pumps can be fitted with manifold water connections, so that either pump may be employed on boiler-feed or for general service as required, the second unit thus serving as a stand-by. Duplex pumps, on the other hand, are simpler, have an absolute positive steam distribution, and are less sensitive to neglect. The use of flywheel pumps of the single-cylinder type are confined to auxiliary purposes and as feed pumps for the numerous small boilers used on deck or land service; the double-cylinder pump of this type, however, presents the advantage for being compounded on the cross-over system, and can be constructed to work with a greater degree of expansion than possible with the direct-acting simplex or duplex types when worked at full capacity; but obviously to be able to run slow on an early cut-off, an impracticable weight of flywheel would be necessary in order to obtain the required balancing effect. This disadvantage is not present to quite the same degree with geared 2-crank or 3-crank feed pumps—a type in very general use in Continental practice for large power stations—although when electrically

driven their efficiency is considerably reduced when run below normal speed, owing to the waste of current resulting from the methods used for slowing down the motor to an extent as frequently required in boiler-feed practice. Other types in use for this purpose are variable delivery pumps and turbine pumps, both of which are described in Chapters XVI. and XVIII. ; to which may be included also the pulsator pump, a device working on the displacement principle, and adaptable under certain conditions where a high economy is not essential ; and lastly, the various adaptations of the injector principle—both in simple and compound form—as extensively used in locomotive practice, which extremely compact and useful boiler-feed device is separately considered in the following chapter.

Before proceeding to describe the various types of pumps that may be used for boiler feeding, a few remarks dealing with the thermal aspect of this application will be appropriate. The theoretical quantity of steam required to force water at equal pressures is that which will raise the temperature of the water pumped from 5° to 6° F. ; in practice, a high class compound pump will use from 2½ to 3 times this amount ; pumps taking steam for the “full” stroke 4 to 5 times this amount ; and pumps working at “less” than their full stroke, owing to faulty valve gear or other causes, may use from 7 to 9 times the amount of steam theoretically required, from which it should be gathered that great care is necessary in the selection of a pump that may be reasonably expected to work with any approach to economy in general use.

Boiler-feed pumps are required to work at a great range of speed, and in consequence of this the direct-connected simplex and duplex types are found to be the most suitable and economical when fitted with gears ensuring the completion of the plunger stroke in both directions. In general good practice the water plungers of pumps of this class are made double-acting, and fitted with ebonite water sprung packing rings, composition liners and rubber disc valves arranged in group form. The speed may be automatically controlled by the water level in the hot-well by a float acting on the steam supply. Pumps of this class must be capable of running dead slow, and be self-starting from any point of the stroke.

Steam distribution is usually effected by a steam-thrown slide, piston, or Corliss valve, controlled by a pilot valve actuated by a rod connected to the main crosshead on the “lost-motion” principle, the essential requirements of which is a gear that will traverse the distributing valve across the neutral point without any liability to sticking fast, and also be capable of cutting-off the steam admission at a point in the stroke to suit the speed the pump is required to work at. In determining the capacity of a feed pump it is usual to allow 20 lbs. of feed water per I.H.P. per hour. In describing with an approach to completeness the various classes of boiler-feed and service pumps in general use, several examples illustrating the best-known makes must be considered, and in commencing their description with those of the generic type known as “simplex pumps,” the various makes are taken alphabetically.

SIMPLEX PUMPS.

Proceeding, therefore, on these lines with a description of the “Blake-Worthington” direct-acting pumps of the simplex class which are supplied in great variety of form and size, we find the general characteristic in design, whether used for boiler-feed or general service, to consist essentially of a double-acting steam cylinder, which is supported—in the vertical form by wrought-

iron pillars, and in the horizontal by a cast-iron distance piece—from the water end, containing a double-acting piston or ram plunger which is directly connected to the steam piston, the construction so far being in common with all pumps of this class. Another feature of similarity is the construction and arrangement of the pump valves, these having in many cases rubber discs supported by brass backings held up to brass seatings by brass springs, the valves being generally arranged in sets, which are superposed to one another, and usually contain three or four valves in group form. All pumps of the direct-acting type are invariably fitted with brass liners, plungers, and pump-rods, the two rods being connected together by a sleeve which either carries an arm or is pivoted to a link for actuating the distributing valve mechanism. It will be understood that for parts made in "brass," alloys of various composition are used as found most suitable for their particular function, and that great care is usually taken in the selection of all material used in the construction of this class of pump.

It may be said, before describing in detail the action of the distributing valves as used in the various makes of pumps, that in all single-cylinder, direct-acting engines some means must be provided to traverse the valve across the neutral point other than can conveniently be obtained from a movement communicated from the motor piston-rod, which cause explains the *raison d'être* of the use of the several forms of steam-thrown pistons or "shuttles," controlled by pilot valves or other equivalent means; the only exception in this regard to the writer's knowledge being the "Bradford" pump, the action of which will be explained later. In the "Blake" pump, of which a sectional diagram is shown by Fig. 86, this action is obtained by means of the steam-thrown piston shuttle B, which is controlled by the ports X and X¹ and extension to the main slide valve C, which is actuated mechanically by the rod P for a short distance towards the termination of each stroke of the motor piston A. The main valve D, which controls steam to and escape from the main cylinder by way of the ports H, H¹, and M, and ports E, E¹, and K in the valve C, is traversed by the pistons B. As shown in the drawing, D is at the left-hand end of the stroke and C at the right-hand end. Steam can, therefore, enter the cylinder through the ports E and H, meanwhile the exhaust is permitted to escape by the ports H¹, E¹, K, and M, and the piston A will be caused to move from right to left. Now, towards the completion of this stroke, an arm on the sleeve will move the rod P, and thus the valve C, together with the side extensions controlling the ports X, X¹, N, and N¹, from right to left, which movement admits steam to the left end of shuttle B, thus forcing it together with the main valve D from left to right, for the movement of C will have opened port N¹ and closed N, and at the same time port X will have been put into communication with Z. The two slides C and D will now have positions opposite to that shown and will admit steam through E¹ and H¹, and exhaust through H, E, K, and M, and thus cause the main piston A to move from left to right. The piston A is prevented from striking the cylinder covers by reason of lead given to the valve D by the shuttles B. This is even so should the movement of the shuttle be tardy, for in this case steam will be admitted in front of A before the completion of its stroke, as the stroke of C exceeds that of D. Cushioning of the shuttles B is likewise effected by the steam entrapped between X or X¹ and the covers of the supplemental cylinder.

Another form of distributing valve is used in the Worthington—"Simplex" type of pumps, which, as in the case of the "Blake"-Worthington, are made in vertical and horizontal form, and proportioned for various adaptations, such as feed, hot-well, general service, air pumps, etc. In the illustration which

shows a standard design of vertical feed pump (Fig. 88), the main valve V is cast together with a shuttle piston situated at each side of the steam chest. These

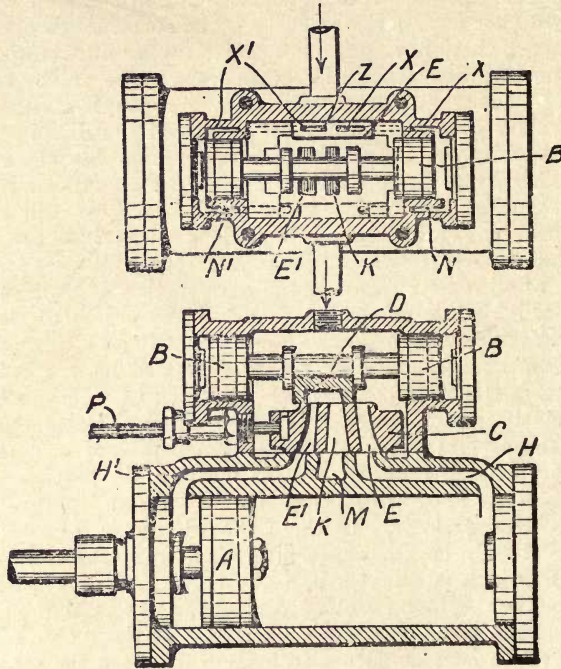

Fig. 86.—Sectional Views of Cylinder, showing Steam Distribution in Blake Direct-acting Pump.

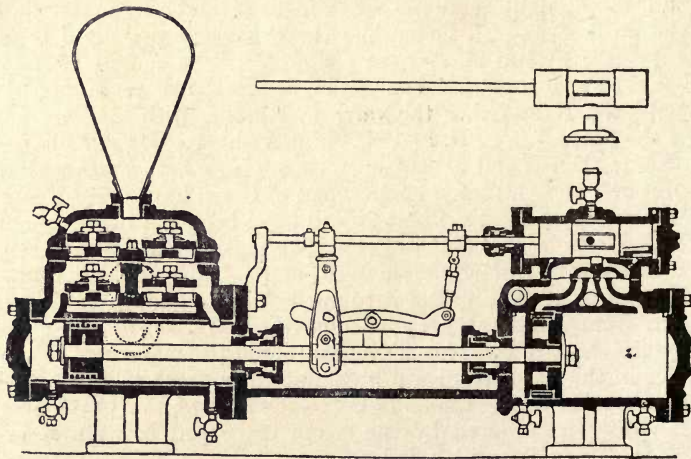

Fig. 87.—Blake-Knowles Simplex Pump.

pistons are moved by steam controlled by the pilot oscillator P, which obtains its movement towards the end of each stroke of the pump-rod M by means of

the lever L, rod D, and tumbler R. In this case the separate steam and exhaust ports S and X in the steam cylinder are arranged end to end on the valve face, through which steam is admitted to and exhausted from the cylinder A by the horizontal movement of the valve V, there being a cushioning effect given to the pump piston by reason of the exhaust being entrapped for the portion of the stroke from X to S, quite independent of the movement of the distributing valve mechanism.

Blake-Worthington and Worthington-Simplex direct-acting pumps are made in great variety of form to suit the numerous purposes for which a steam pump of this character may be usefully applied, of which in connection with large power installations using steam at high pressures a great number of boiler-feed and pressure pumps have been supplied of this make arranged to work in pairs on the cross-over compound system, one side being used as a hot-well lift pump, and the other for boiler feeding, their action being made automatic by means of a float control. Another type of simplex pump is the Blake-Knowles boiler-feed and general service pump illustrated by the sectional view, Fig. 87. In this pump, which is seen not to differ very widely from the preceding other two types of pumps of this class, the main steam slide valve is operated by an auxiliary piston shuttle, which works in the steam chest at the back of the main valve. The peculiarity in this instance is in slightly rotating the auxiliary piston shuttle—which thereby acts as a pilot valve—by the valve motion through the medium of a tappet and roller attached to the pump-rod crosshead, which engages a rocking lever that carries at one end an adjustable connecting link by which the valve-rod is partly rotated. This movement places ports in the piston valve in communication with others in the steam chest, by which means steam pressure is caused to act on one end of the piston valve, thus "throwing" it together with the main valve. The rotative motion opens the port to steam at one end and simultaneously a port at the opposite end to exhaust.

There is no point of the stroke at which either the piston valve or main valve is not directly exposed to steam pressure, there being no lap on the valve, and consequently no expansion in the main cylinder. As in other pumps controlled on the "lost-motion" principle, the length of stroke is capable of adjustment, due attention being required in this distributing gear so as to ensure that the tappet arm on the pump rod shall strike the rocker bar at equal distances on each side of the centre, "a precautionary measure necessary in nearly all pumps of this class."

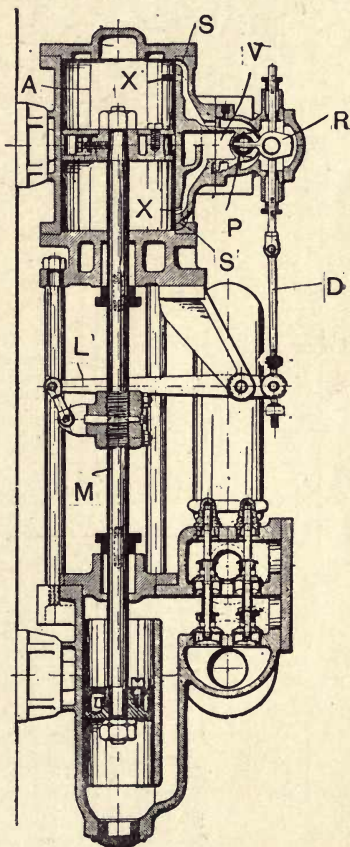

Fig. 85.—Sectional Elevation of Simplex Feed Pump.

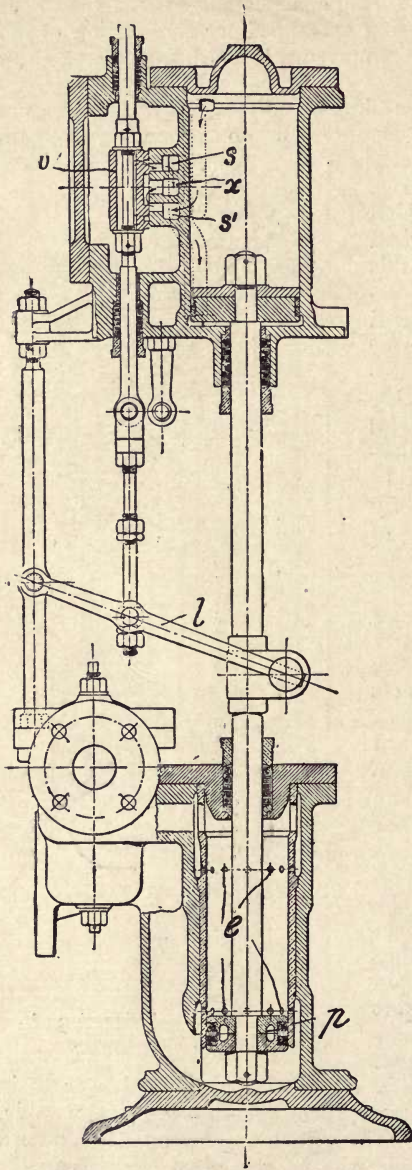

Fig. 89.—Sectional Elevation of the Bradford Patent Boiler Feed Pump (Slide Valve Type).

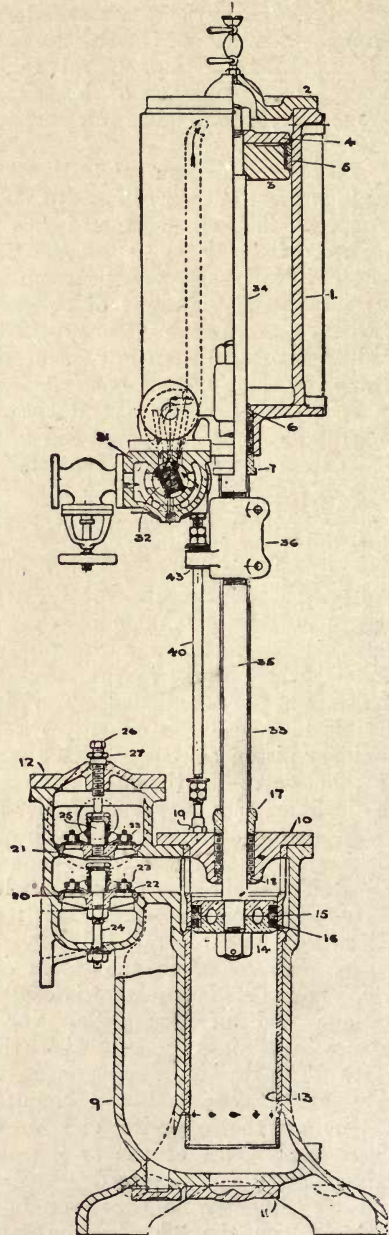

Fig. 89a.—Sectional Elevation of a later form of Bradford Boiler Feed Pump, with "Corliss" Valve Steam Distribution?

The illustration (Fig. 89) shows a wide departure in the usual practice followed in the construction of direct-acting simplex pumps, the particular construction used in the Bradford boiler-feed pump having been adopted in order to dispense with the usual auxiliary pilot valve and shuttle pistons serving the purpose of traversing the main valve, and of also avoiding thereby any liability to stop at the neutral point. In this pump only one steam valve is used, which will be seen by the section, is an ordinary slide operated by a lever and rod from the pump-rod crosshead on the usual "lost-motion" principle. There are three ports on the cylinder face, and the two outer ports cross over one another, so that each may communicate with the end of the cylinder most remote from the port on the valve face. Thus, referring to the section where the piston is shown at the completion of its down stroke, the valve is traversed by the lever to uncover the upper port, thereby admitting steam to the under side of the piston, and placing the top side open to the exhaust, as indicated by the arrows. The valve will remain in this position until the steam piston has arrived at nearly the termination of its upward stroke, when the lever will carry the valve up with it, and thus reverse the steam distribution. In order to prevent the pump plunger stopping while the valve is being traversed across its neutral point—*i.e.*, when it is alike closed to both ends, the plunger at this point places itself in equilibrium by uncovering a row of holes in the pump liner, thus permitting the steam to complete the stroke, however slow the pump may be working, the travel of the valve being exceedingly short, in order to avoid the cushioning effect of admitting steam before the end of the stroke, which, with an excessive load, would result in preventing the pump from being worked dead slow. This method, although not admitting of the slightest degree of expansion, compensates for this by the extreme simplicity in the construction of the steam end of the pump, and in avoiding the possibility of the pump stopping owing to the valve sticking fast. In the pump end the ordinary construction is followed, excepting as regards the perforated brass liner, ebonite rings being used in the plunger and manganese valves arranged in group order.

In a later pump of this make the slide valve shown in Fig. 89 has been replaced by a Corliss valve, which works in a separate valve chamber attached to the main steam cylinder casting by four bolts, for which construction one of the advantages claimed is that a complete valve and valve chest can be fixed to the cylinder should such change be required. Another point in the working of the new form of pump is that the Corliss valve can be operated from the piston-rod by means of a single working joint; in other respects the construction and *modus operandi* of this pump is essentially as above described.

In the Burnham simplex direct-acting general service pump illustrated in section by Fig. 90, the steam distribution is obtained by the rocker (A) lugs (L), rod (T), and pilot slide (H), which is traversed in a direction opposite to, and in travel about one-fifth, that of the motor piston. The motion thus imparted to the pilot slide admits steam alternately through the double ports (P) and (C) to each end of the valve cylinder, thereby causing the piston valve (M) to traverse the main slide valve (D), which in its turn admits steam to the main cylinder through the double ports (E) and (G), the latter only serving to admit steam for the first portion of the stroke, the larger ports (E) being situated some distance in from the cylinder covers to cushion the action of the pump, and to cause the initiatory movement of the pump piston to be slow, thus imparting to the water column a more gradual acceleration than obtained in the ordinary manner, and relieving the pump and piping of unnecessary strain. When required to pump heavy and thick liquids, such as tar, molasses, mash,

slush, etc., the water end is fitted with bell valves, as shown at (V), which have the advantage of the spherical form of valve, but without their weight, the cup formation also causes the valves to close more quickly and with less pounding action on the seats; these valves, as shown, are arranged in pairs, have removable

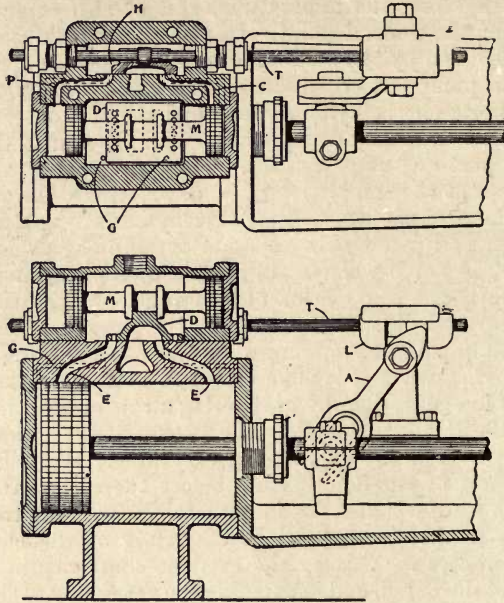

Fig. 90.—Section of Steam Cylinder, showing Distribution used in the Burnham Simplex Direct-acting Pump.

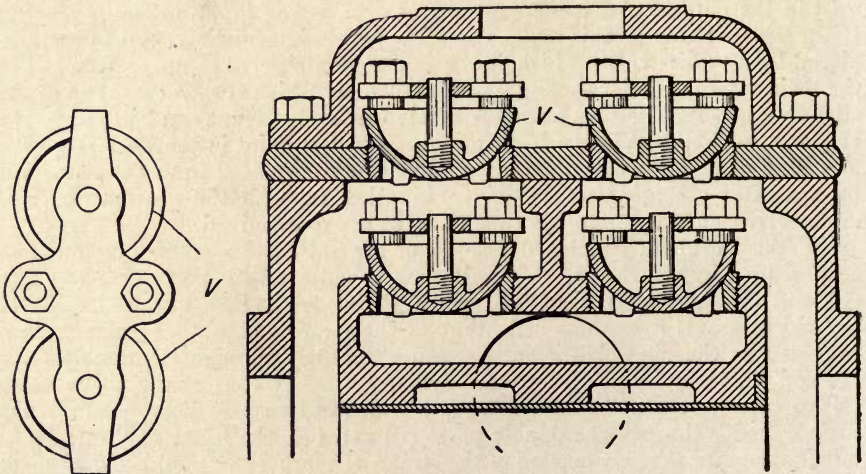

Fig. 90a.—Section showing Spherical Valves used in Burnham Double-acting Pump for Thick Fluids.

seats, are fitted with guide stems and occupy no more head room than the ordinary disc valve.

The Caird & Rayner boiler-feed pump, illustrated by Fig. 91, presents some features of practical usefulness—*e.g.*, in working with an effect somewhat similar to that obtained by a pausing gear, thus allowing time for the water

valves to settle, and thereby avoiding unnecessary stress on the water-feed connections. The general construction of this pump is not widely dissimilar to others of this class, the action of the steam-distributing mechanism resembling in some degree that shown by Fig. 88—*viz.*, (1) in there being separate steam and exhaust ports to the cylinder; (2) in the exhaust ports being arranged some distance in from the cylinder ends so as to entrap a portion of the escaping steam to obtain a cushioning effect; (3) in the main valve receiving a horizontal movement from two shuttle pistons. The similarity, however, ceases at this point, as in the pump now under consideration the shuttle pistons (7) are entirely separate from the main slide valve (6), thus enabling this valve to wear on to its face without affecting the actuating pistons, on which wear is in consequence practically nil. The auxiliary or pilot valve face is provided with ports which communicate with the ends of the subsidiary cylinders carrying the two shuttle pistons which traverse the main valve. These ports are opened alternately to steam and exhaust, and cause the main valve to be thrown from side to side by a vertical movement imparted to the pilot valve (5) by a rod and lever from the pump-rod crosshead in the ordinary way. By the disposition and proportioning of the cylinder steam and exhaust ports, the speed of the piston is reduced when approaching the end of each stroke, this arrangement also preventing the piston from striking the ends of the cylinder should the water supply to the pump for any reason fail, a feature that would result in being of some importance in the event of a fractured pipe or other cause. The pump valves (18)

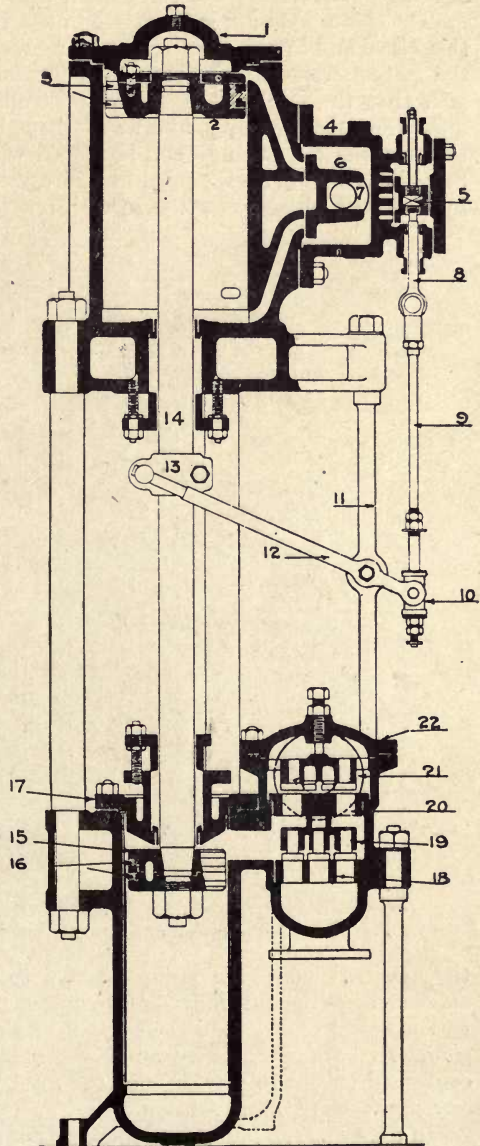

Fig. 91.—Caird & Rayner Feed Pump.

are arranged in groups, and differ from usual practice in being guided in an overhead frame (19), and by this means afford a very free waterway, and should thus avoid any side wear in the seating (20); the plunger (15), as in the case of other pumps of this class, is packed with ebonite rings (16).

The steam cylinder is by far the most important consideration in pumps of this class, and in the next example, represented in a very forceful manner by the photo-sectional engraving, Fig. 92, known as the "Cameron," it will be seen that the method adopted for controlling the distribution does not widely differ from the preceding, and will perhaps be seen to resemble somewhat closely the steam-distribution system identified with the Tangye simplex pump, there being in this, as in that, a pressure-thrown slide valve constructed to be traversed by a shuttle piston, which is in turn regulated in its movement by tappets in

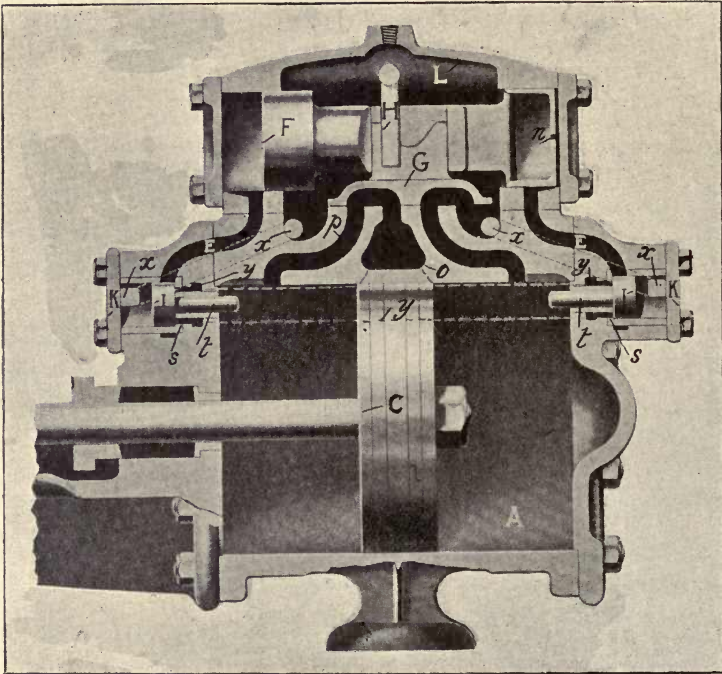

Fig. 92.—Photo-Section of Steam Cylinder of Cameron Direct-acting Pump.

the cylinder ends; the pump referred to and the present example are both alike in being operated by direct contact of the tappet stems with the power piston near the termination of the stroke each way, thus requiring no outside gear. In both of these examples communication with the pressure supply is continued for the full stroke, no attempt being made in either case to obtain any advantage from expansion.

In the Cameron pump, spring-closed tappet valves are superseded by piston pilots (I) arranged to be closed by steam pressure, but differ also in being fitted to work in line with the power piston instead of at right angles to it. The cylinder ports (*p*), as is usual with this type of pump, are located some distance back from the cylinder ends, so as to cause a cushioning effect. In action the power piston (C) soon after closing to the exhaust, contacts with one of the tappet

stems (*t*), and thus forces one of the pilot pistons (I) outwards against steam pressure supplied along the auxiliary port (*x*). This action uncovers one of the shuttle ports (E) communicating with one or the other end of the hollow shuttle piston (F), which, being steam-thrown in this manner, carries the main slide valve (G) with it, thus causing it to be traversed to its full extent in either

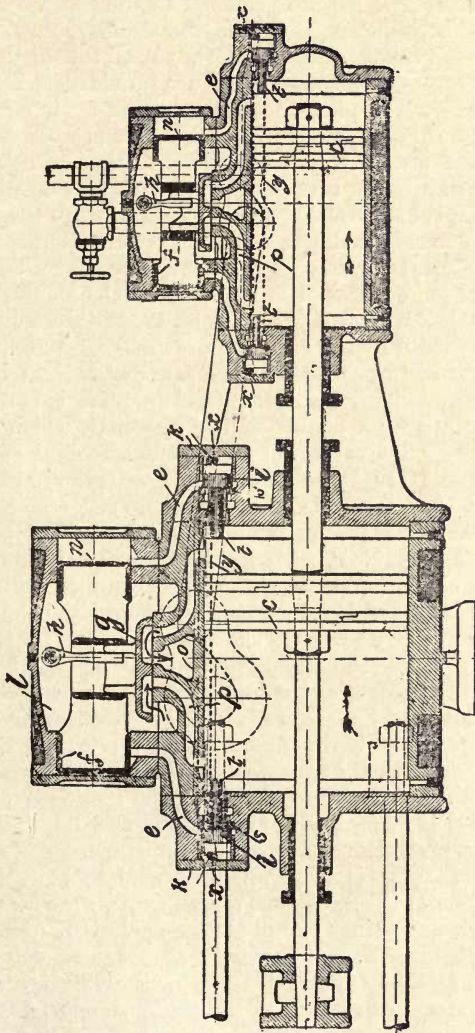

Fig. 93—Section of Steam Cylinders of "Cameron" Compound Direct-acting Pump, showing Method of actuating the Steam-thrown Valves

direction, a lever (H) being provided for correcting the movement of the shuttle at starting.

In the illustration representing an adaptation of the Cameron pump having compound cylinders, Fig. 93, the two power pistons are shown in a position nearing the completion of the outstroke, the two shuttle pistons having been shot over to the left at the termination of the preceding stroke, and towards the completion of the present stroke will be thrown to the right owing to the

effect of the power pistons (*c*) in coming into contact with the tappet stems (*t*) at this end, thereby causing the pilot pistons (*i*) to uncover the shuttle ports (*e*), when pressure from the out ends of both shuttle pistons (*f*) will be released along the auxiliary exhaust passages (*y*), with the effect of causing both shuttles to be quickly forced over to the right, and by this means to reverse the direction of the pump plunger. Apertures (*n*) are provided to compensate for end balance to the hollow shuttle pistons, they, therefore, remain fixed until the completion of the stroke. The piston ends of the pilots (*i*) are at all times subjected to steam pressure, for which purpose auxiliary ports (*x*) are provided, which communicate with the steam chests (*l*), the pilots normally resting against seats (*s*) except for the short periods during which the tappets are held open by contact with the ends of the power pistons. The advantage claimed for this method of steam distribution is the quick reversals obtained by exhausting one end of a balanced shuttle and the absence of outside gear, also by the removal of the covers (*k*), the parts requiring the most attention are quite easily accessible.

The illustration (Fig. 94) represents the general construction of the Clarke-Chapman latest model for boiler-feed and general service pumps of the simplex class, the most notable feature of which is the "Woodeson Corliss" steam distribution, shown in detail by the sectional drawings (Fig. 95). Referring first to the general design, it will be seen that the steam end differs from either of the foregoing in having an oscillating valve, to which steam is supplied at A, the valve being steam-thrown by a double-shuttle piston G, which is in turn controlled by an oscillating pilot valve working about a rocking spindle H that is connected by a lever and rod D, so arranged as to be actuated on the "lost motion" method by an arm carried by the pump-rod crosshead. Steam is admitted to and exhausted from the cylinder by one pair of portways T, the exhaust outlet being at B. Now, referring to Fig. 95, which represents cross sections of the valve chamber, showing the valves in two positions—viz., the position of the valves as moved by the actuating lever S, and the piston showing the continued movement obtained from the shuttle pistons G. The main valve C and pilot valves D and D¹ are oscillated on to a cylindrical face by the lever S, shuttles G, and steam pressure, the two pilot valves being held in position by a carrier E and valve C by an arm F; and all three, being loose segments, are held up to the face of the valve chest by steam pressure at the back. The double piston G, which is partly actuated by the lever S through the spindle H, and completed by steam pressure, oscillates the main valve C through the arm F. The carrier E is formed with two lugs K and K¹, and is forged solid with the spindle H, upon which the arm F is free to turn.

The *modus operandi* of this distribution is as follows:—When the main piston is nearing the end of the stroke the tappet arm on the crosshead oscillates the lever S through D, and brings one of the projections K or K¹ of the carrier E into contact with the arm F, and thereby actuates the whole gear, including pistons G, valve C, and pilots D and D¹, "mechanically," until the ports L and M are open to either steam or exhaust, when the movement of the pistons G is completed by steam pressure, this further movement carrying with it the arm F and distributing valve C, the subsidiary cylinder exhausting through L or M to recesses in the pilots and thence by portways N and N¹ to the exhaust outlet at B. An important feature of this valve gear is that both main and pilot valves can be quire freely actuated by hand from the outside by the lever S, thereby admitting steam to either end of the main cylinder, the movement of the valve giving a sharp admission and lending itself to obtaining a certain degree of cut-off by adding the necessary lap.

The oscillating or Corliss type of distributing valve is found to be exceedingly free in its movement, as well as being durable and perfectly steam-tight, and well repays the slight additional cost involved in its manufacture. The distribution, moreover, lends itself, with the addition of two portways in the valve chest, to the construction of pumps working compound, the distributing mechanism being in this case bracketed to the low-pressure cylinder. The water ends are constructed either with a double-acting piston plunger or with a centre-packed ram plunger, which latter is more suitable for very high pressures

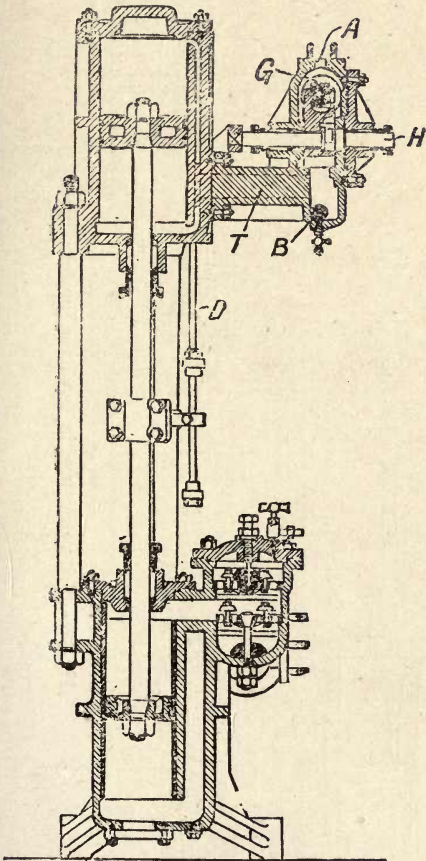

Fig. 94.—Sectional Elevation of Clarke-Chapman Direct-acting Feed Pump.

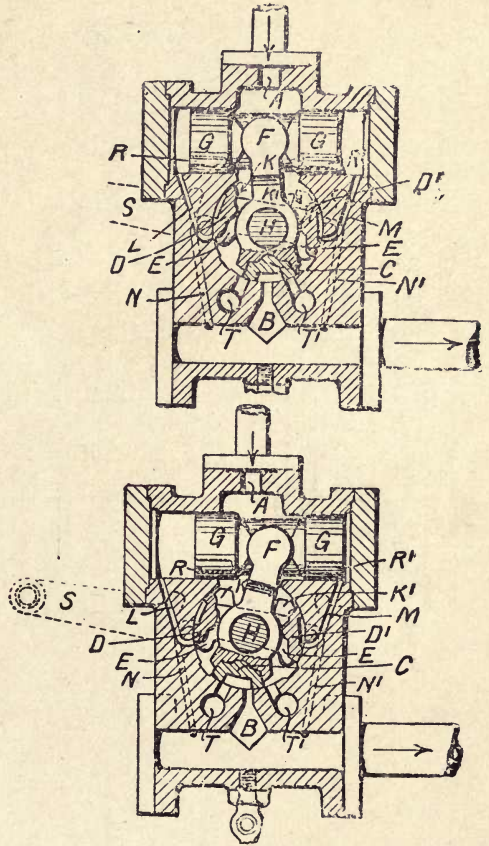

Fig. 95.—Detail of Woodeson Distributing Valve.

or for colliery work, or for other purposes where the water is liable to be gritty. It may be mentioned that a strong feature in connection with this class of pump is their combination in pairs mounted on a float tank fitted with automatic control gear, consisting of an open float kept poised by a balance weight. There is in this construction no risk of derangement from leakage or collapse, as in the case of an ordinary float ball. In action, water from the hot-well is pumped directly into the open float which rises or falls according to the depth of water

in the tank, and by a simple connection with a throttle automatically regulates the feed supply to deal with the requirements of the boilers. By the same means the pump may be either stopped or started with the main engines, their rate of working being entirely controlled by the supply of water from the hot-well to the open float of the control gear.

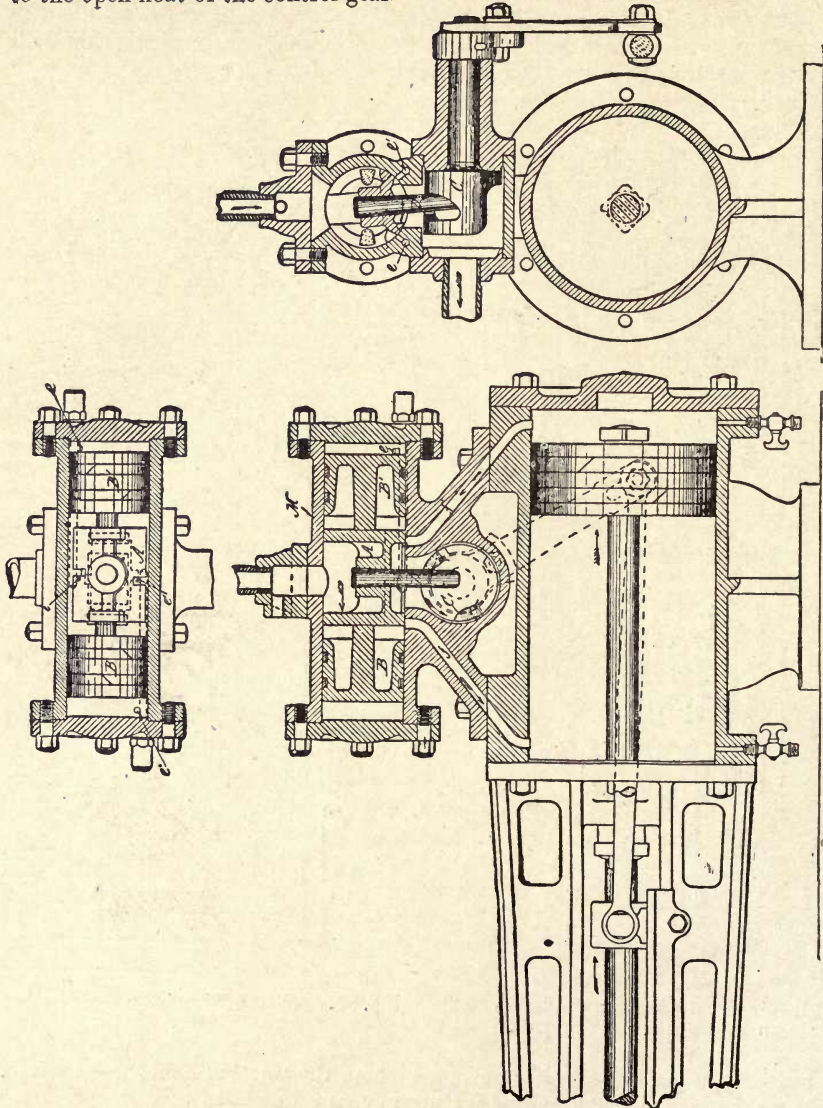

Fig. 36.— Valve Gear used in Davidson Simplex Pump.

The most interesting part of the Davidson simplex pump is the valve gear, illustrated in section by Fig. 96, the special feature being the valve used in the high-pressure cylinder; this is steam-thrown, and closed by a mechanical connection with the main piston-rod. Referring to the sectional cuts, M is a cylindrical steam chest bored out to make a face for the valve A and the pistons

B and B¹, which assist in operating the valve. These pistons are connected together, sufficient space being allowed between them for the valve and steam ports; the pistons are also attached to the slide valve, all working together in the same plane and being of the same diameter insure evenness of wear and readiness of access for adjustment and repairs. The valve A is controlled and operated by the cam C, acting on the steel pin D, which passes through the valve to the exhaust port in which it will be seen the cam is located. In addition to this mechanical movement, steam is alternately admitted to and exhausted

from the steam chest by the ports (e) and (e¹), thus assisting the movement of the valve by steam pressure actuating the pistons B and B¹. The operation of this distributing mechanism is as follows:—When the engine is at rest with the valve A covering the main steam ports (f) and (f¹), the cam C holds the valve so that steam will be admitted to one end of the chest and exhausted from the opposite side by the ports (e) and (e¹), thus throwing the valve and thereby opening the main steam ports (f) and (f¹), by which means steam is admitted to and exhausted from the steam cylinder. Now, if the valve occupies any other position, one of the main steam ports will be open to steam and the other to exhaust, thus insuring a direct supply of steam to one end of the cylinder, and a rapid release of the exhaust steam from the other end, there can consequently be no dead points and the pump must start from any position. The steam cylinder piston is, moreover, prevented from concussion with the cylinder head by reason of the positive cushioning effect given, and further as the valve is positively actuated by a mechanical movement, there can be no such contingency as "sticking up," and the pump is enabled to fully complete its stroke in both

directions with a regular action. Ordinary slide valves are used for the distribution in the low-pressure cylinder, the movement of the valves for both cylinders being obtained from one lever connection.

There are one or two features of interest in the Karoome direct-acting boiler-feed pump, which consist, as shown in the illustration (Fig. 97) in the use of a removable liner L in the water end of the pump, and two pairs of steam and exhaust portways S and E in the steam cylinder. The distribution is obtained by

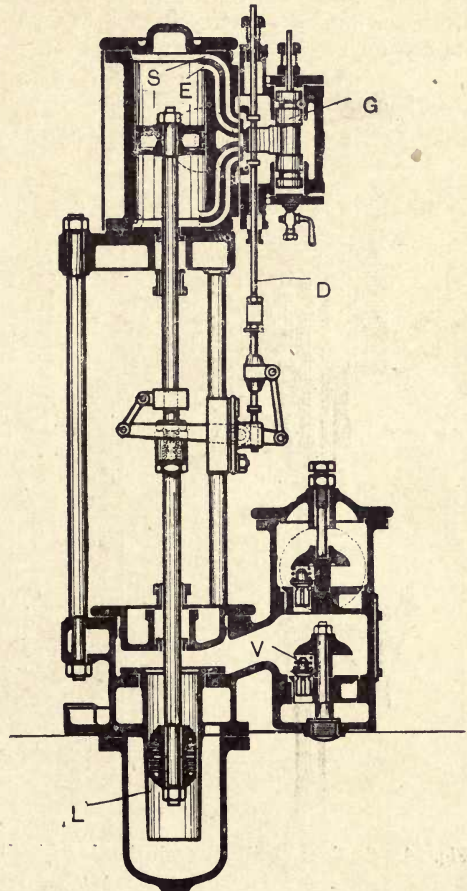

Fig. 97.—Sectional Elevation of Karoome Feed Pump.

a slide valve, which receives a part traversing movement from the pump-rod in the usual manner, which movement serves to uncover auxiliary portways communicating with a pair of auxiliary cylinders in the valve chest, by which means the motion of the distributing slide valve is completed by steam pressure acting on a double-shuttle piston G. The most important feature in the Karooe pump, however, is to be found in the use of the removable liner, by which construction the delay and expense of reboring after extended service with water containing gritty material is avoided.

In Lamont's simplex pump for boiler-feeding, bilge-clearing and other service work, an auxiliary piston P, *vide* Fig. 98, is traversed to a point a little over its central position by the main piston B through the rod C, clamp E, lever

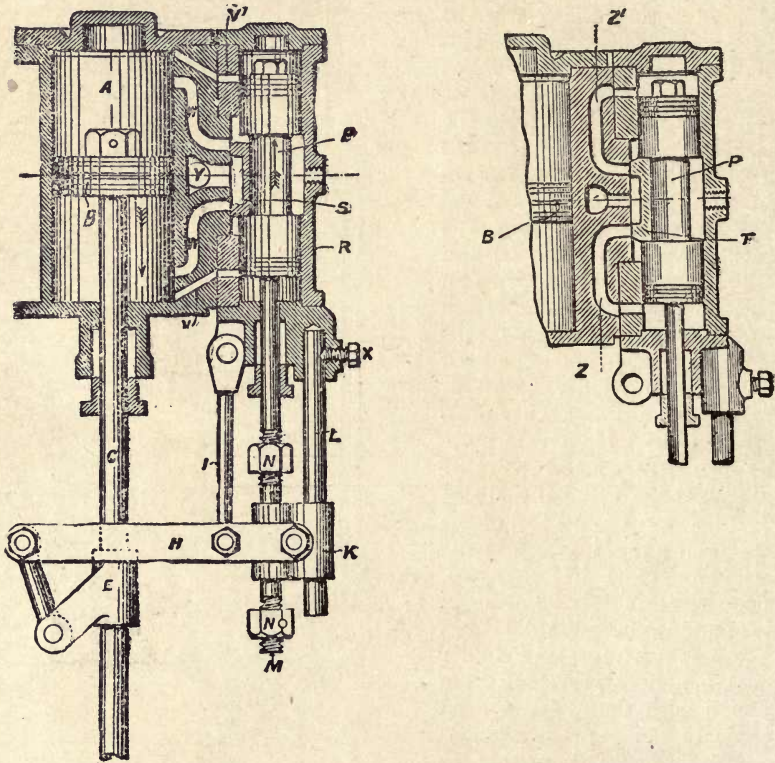

Fig. 98.—Sections of Steam End, showing Distribution in Lamont's Simplex Direct-acting Pump.

H, block K, stop nuts N, rod M, and link I; this action places one end of the auxiliary cylinder R in communication with pressure steam, in traversing the slide valve T upwards, so uncovering port Z, and simultaneously opening the upper end to the exhaust outlet Y, whereby the piston valve P, and with it the two slides S and T, are traversed to the extent to fully open the main ports W, one to pressure steam and the other to exhaust. By this action the piston P uncovers the supplementary port V, and closes V' to the end of the stroke; as the opening and closing of V and V' by the slide S synchronises with the opening and closing of the ports Z and Z', steam is admitted

to that end of the cylinder R by the slide T, and conversely as soon as T exhausts either end of R, the port in that end V or V¹ is covered by P.

In the illustrations the main piston B and slide valve T are shown in the central position, but the main slide S is still open, and will cause the main piston B to move downwards until it passes the bottom port W, which is open to the exhaust, after which it will gradually be brought to rest by the entrapped steam. The stop nuts N, N are fixed on the valve-rod M in such a position that the block K moves the piston P slightly over the central position before the main piston is at the end of its stroke; the slide valve T will then admit steam through port Z to the under end of R, and simultaneously the upper end of R will be opened through Z¹ to the exhaust; by this action pressure steam will thus be caused to traverse the auxiliary piston P, and with it the slides S and T, upwards, and so reverse the steam and exhaust passages to the main cylinder, but as the piston B still covers the port W, steam will, therefore, be only admitted by way of V until B has moved so as to uncover W when the full flow of steam will be admitted.

In the Michael simplex direct-acting pump (horizontal) illustrated in section by Fig. 98a, there is no steam-thrown valve action at all, the distribution being obtained

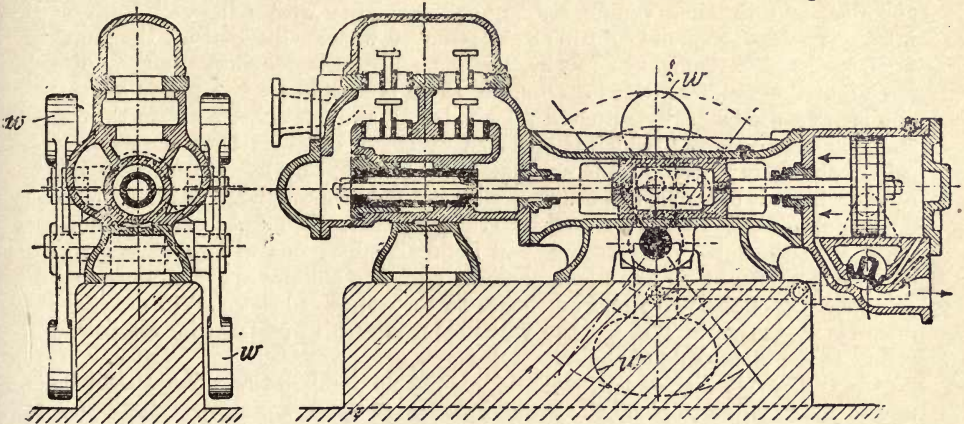

Fig. 98a.—Michael's Simplex Direct-acting Pump, with Compensating Balance Weights.

by an oscillating valve connected direct with the pump pistons, and to cut-off at about half-stroke as shown. In order to equalise the movement and compensate for the falling steam pressure during the latter half of the stroke, the crosshead is connected to a pair of heavy oscillating balance weights (*w*), which act the part of a flywheel, but must obviously be very heavy to equalise the movement of a pump slowed down below normal. However, by a test made with a pump provided with balance weights, it has been proved that at a plunger speed of 270 feet per minute, a 5-inch diameter double-acting plunger is capable of delivering 2,400 gallons per hour against a head of 300 feet, with a cut-off in the steam cylinder (12 inches diameter by 10 inches stroke) at half-stroke. This result, as good as it is notwithstanding, it is doubtful whether any commensurate advantage can be obtained by this means in a general service pump required to be run at a greatly varying range of speeds, for obviously at speeds much above normal a correspondingly increased cushioning effect would of necessity have to be arranged for, while for slow running the weight (*w*) required

at the limited radius at disposal in order to equalise the thrust on the plunger would be impracticable; but with the use of compensators arranged to operate on the pressure principle, the action is altogether independent of the running speed of the pump, this method lending itself in an almost ideal manner for balancing the power to the resistance throughout the stroke, and can be simply and automatically regulated by adjusting the pressure acting on the plungers to suit the varying requirements of the pump, and in point of construction still leaves the direct-acting pump with a great advantage in reduced cost of manufacture and fixing down, *vide* Figs. 21 to 26. It is questionable, however, whether equalising plungers can be economically applied to a pump of the size required for ordinary service work.

The Nichols direct-acting simplex feed pump, although in the main following closely on the lines of other pumps of this class, differs in one or two important details—*viz.*, in providing means for working expansively and in using steam which has already completed its work on the main piston to actuate the distributing valve. Another feature is the convenient manner in which the distributing mechanism lends itself for use with compound working, in which construction the high-pressure cylinder is arranged over the low-pressure cylinder, and the intervening stuffing-box provided with a special form of metallic packing, so enabling same to be removed without dismantling the pump further than the removal of the high-pressure piston and cylinder cover. Referring to the sectional drawing, Fig. 99, there is seen to be two piston valves, one being a mechanically-actuated pilot valve P, and the other a steam-thrown shuttle action valve M, which is operated by steam obtained from the exhaust side of the main piston, and is not, therefore, operated by live steam, although its movement is controlled as usual by the pilot valve through a pair of auxiliary ports (not shown). Steam is supplied to the pump through one of a pair of inclined ports V in the pilot valve casing, and is admitted by one of two other ports oppositely arranged, so as to communicate with the annular space at the lower or upper end of the valve M, and thence to the upper or lower end of the main cylinder by the ports T or T¹, the valve being shown in position for admitting steam to the under side of the piston S.

On the completion of the stroke—*i.e.*, the up stroke—the valve P will be moved down so as to close the lower inclined portway V and open the upper portway, also communicating with the steam chest. N.B.—The point of cut-off is capable of adjustment from without by a part rotation of P by means of the handle N, thus bringing into action the wedge-shaped portion of the pilot valve. This movement of P by the lost-motion gear L has the effect of first admitting steam from the under side of the main piston to the under side of M through an auxiliary port (not shown), and of also placing the upper end of M in communication with the exhaust, when by another port (not shown) M is moved up, thereby opening the under side of the main piston to exhaust—*i.e.*, causes T¹ to communicate with X, and at the same time places the upper side of S into communication for the supply of live steam from V through M and T, and in this way causes a reverse movement of the pump to take place.

In the construction of a compound direct-acting pump with the Nichols distributing gear, the disposition and arrangement of valves, ports, and cylinders is as shown by the sectional drawing (Fig. 100), the removable stuffing-box with metallic packing F being used in this case in order to keep down the height of the pump, and for the same reason the bottom of the water end can be arranged to project through the floor. In this pump P and M are essentially the same as in the case of a single cylinder, the only difference being the addition of a

third annular steam space in M, the three spaces being denoted by 2, 7, and 5, and control the two pairs of cylinder portways T^1 , T^2 , and C^1 , C^2 . The position of the valves and pistons corresponds to that obtaining at the commencement of a down stroke, and steam is shown to be admitted at the arrow 1 through V, then through the port S^1 opposite as denoted by arrow 2 to the portway

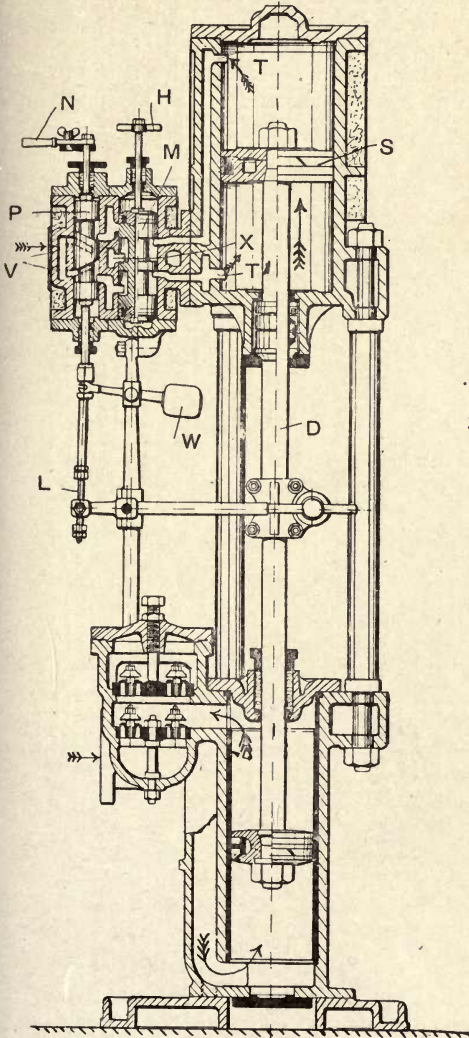

Fig. 99.—Nichols' Patent Simplex Pump.

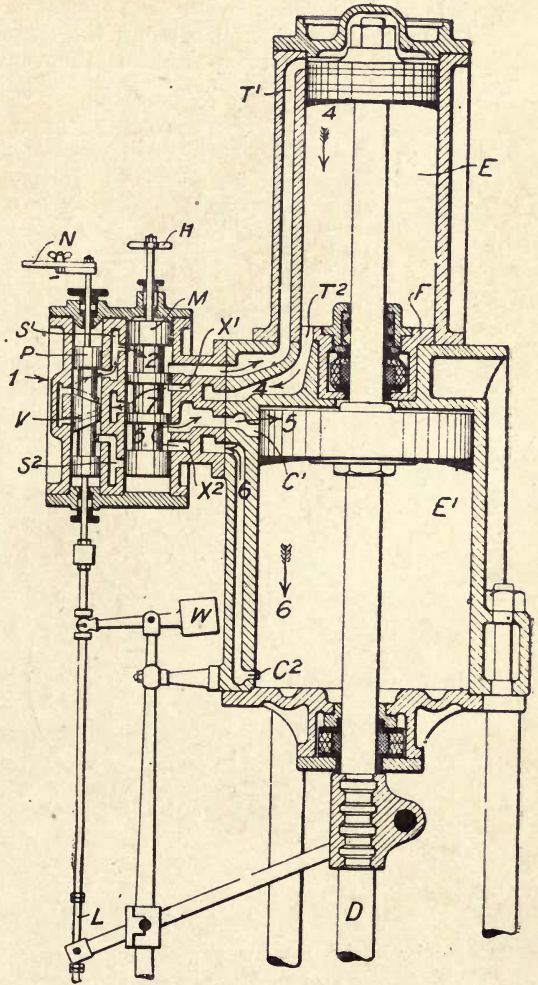

Fig. 100.—Nichols' Distribution applied to a Compound Direct-acting Pump.

T^1 , as shown by arrow 3. Simultaneously, steam will be caused to be transferred from E in the direction of arrow 4 through T^2 to the space 5 in M, and thence by C^1 to the upper end of E^1 , as shown by arrow 5, and steam at the under side of the piston in E^1 will at the same time be exhausted through C^2 in the direction

of arrow 6 to port X¹, which is now placed in communication with the exhaust outlet, as shown by the arrow 7. By the movement of D and motion L, the pilot P thus admits steam to S¹ or S² for a portion of the stroke, as determined by the position of N, and the main valve M controls the admission of live steam to E via the portway T¹ or T², and the exhaust from E to E¹ through ports T¹ or T² to X¹ or X² in the valve casing, and thence through the space 2 or 5 to the portway C¹ or C², the low-pressure cylinder being exhausted above and below by the same movement to the central space 7 in the valve M.

In the Pearn simplex pump the steam distribution is effected by a slide valve, which receives a mechanical movement towards the end of the working

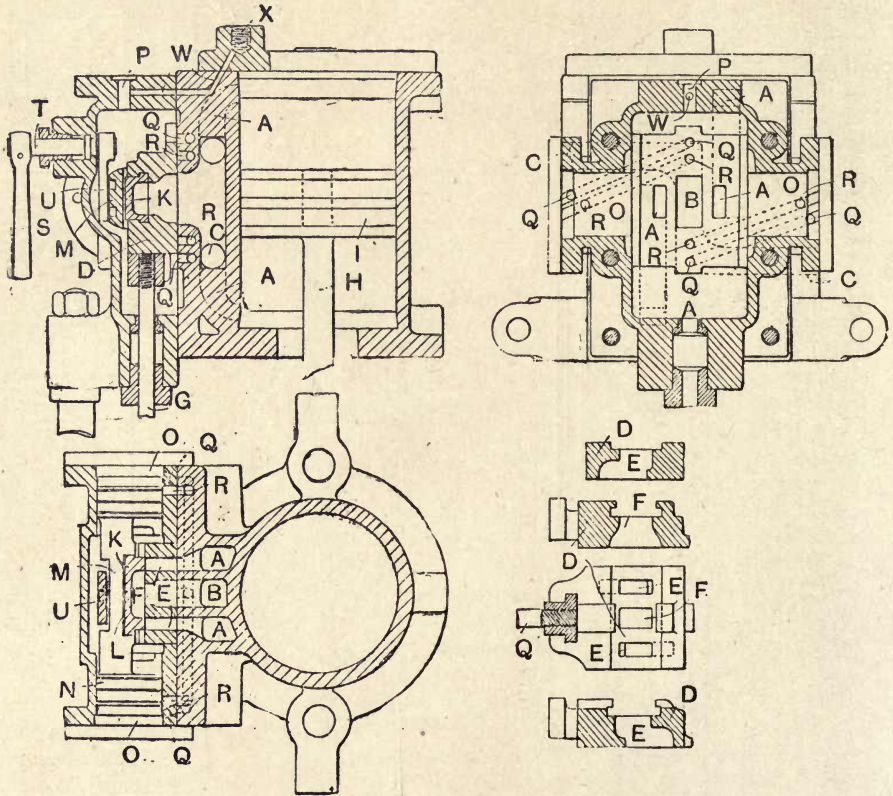

Fig. 101.—Pearn's Simplex Valve Gear.

stroke in the usual way, a cut off valve at the back receiving a to-and-fro movement from two shuttle pistons, the movement of which is controlled by auxiliary ports in the face of the mechanically-moved valve, the description of the several parts being as follows :—In the steam cylinder (*vide* Fig. 101) are two ports A A and one exhaust port B branching into two passages C. These ports are controlled by a slide valve D, having two inlet ports E and an exhaust port F, and receives a vertical movement from the rod G, which is connected to the pump-rod H in such a manner as to move in the same direction as the piston I. The auxiliary valve K is mounted at the back of D, and is caused to move across its

face at right angles by the two pistons N, which work in the subsidiary cylinders O, the valve K fitting in the recess L of the distance piece M, forming the shuttle in combination with the two pistons N. Steam is supplied at P and to each of the cylinders O through ports Q, these, together with the exhaust ports R, being controlled by the valve D. The auxiliary valve K can be operated by hand by the lever S mounted on the spindle T, on which is also mounted a lever U working in a recess, the passage W being provided for supplying lubricant from a feeder at X.

The Pearn distributing gear works in the following sequence:—Assuming the valve D to be at the end of its upward travel, the port R will communicate with the exhaust port B, and the corresponding shuttle piston N will be relieved from steam pressure, with the result that the shuttle M will be thrown over and carry with it the auxiliary valve K, thus uncovering the port E in the slide D, and causing steam to enter the upper part of the cylinder through the port A. The slide D at this point will not have fully uncovered the port A, and in consequence the full pressure of steam will not at first act on the piston I; but as the valve D begins to travel downward it gradually increases the area of steamway to the port A, the full opening continuing until the piston I has nearly completed its down stroke, when the auxiliary port R communicating with the subsidiary cylinder O of the second-mentioned piston N will be opened to the exhaust port B. This auxiliary valve or shuttle piston then being under lower pressure than its companion piston will cause the auxiliary valve K to move across to the other side, thus uncovering the port E leading to the port A communicating with the bottom end of the main cylinder. An examination of the drawings of this gear will disclose many features in common with preceding examples of direct-acting single-cylinder boiler-feed pumps, the prejudicial presence of a number of very small steam passages not adding to the good qualities of a gear which gives evidence in other respects of being carefully thought out.

The Richardson steam distribution (*vide* Fig. 102) is one of several examples of direct-acting simplex pumps designed to obtain the necessary valve movement independent of outside mechanical connection with the pump-rod—*e.g.*, may be cited the distribution adopted in the Weston-Parker pump, made by the Coalbrookdale Iron Company; the Carriburn pump, and the Marsh pump (already described and illustrated by Fig. 38). In the "gearless" pump now being considered, a steam cylinder A with ports B B¹ and exhaust C is used. Subsidiary cylinders F and F¹ form a part of the steam chest E, E¹ being the steam inlet. A valve-rod G communicates motion from the shuttle pistons J and K to an ordinary distributing slide valve, the rod passing through dividing walls R and packing blocks H fitted in halves and pressed together by spiral springs. Of the two double pistons, only the inner parts J¹ and K¹ act as pistons, the outer discs being perforated at L, their function being to cover auxiliary ports M N and M¹ N¹ leading to the cylinders A, F, and F¹. Now, as the main piston S uncovers the port M, steam enters from A into the space Q¹ and acts on the piston J¹, thus pushing over the valve D to the left, and causes the piston J to cover M and J¹ to cover N. During this movement the two pistons at the opposite end are balanced. It will be seen that steam entering the space Q¹ will be able to pass freely through the perforations L L to the outer side of piston J. In the same manner, when the main piston reaches the opposite end of its stroke, steam will in like manner gain access by the passage M¹ to the space between K and K¹, and thereby traverse the valve D to the right, and so reverse the direction of the main piston by opening port B to the steam chest E. The

desired cushioning effect is obtained by the piston S admitting steam to the shuttles through M or M¹ slightly before the completion of the stroke, so causing the valve to be thrown and steam to be admitted in front of the main piston to form a cushion. The auxiliary ports N and N¹, being placed a little way back from the ends of the subsidiary cylinders, serve in this manner to cushion the shuttle pistons, in addition to their other purpose of placing the inner ends of the subsidiary cylinders in communication with the main steam ports.

In the Storey direct-acting simplex pump the movement of the distributing or controller valve is obtained by two auxiliary pistons of differential areas—*i.e.*, the main valve A (*vide* the sectional illustrations, Fig. 103) receives its motion from the two controller pistons C, C¹, which are always open at their inner ends to steam pressure. Now, as the outer end of the smaller piston is always open to the exhaust, the valve is traversed in one direction by allowing full steam pressure to act on the outer face of the larger piston C, thus putting it out of action, and in the reverse direction by placing the outer face of the larger

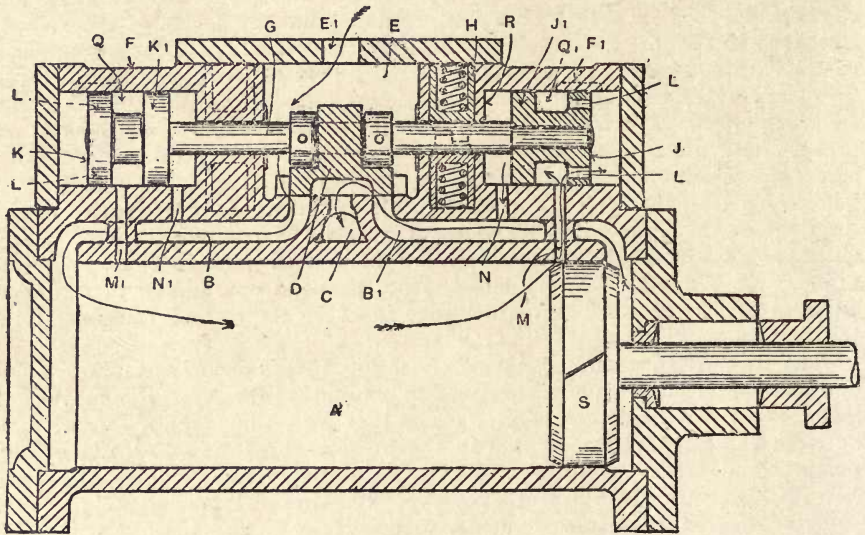

Fig. 102.—Richardson's Simplex Valve Gear.

piston in communication with the exhaust. In the illustrations, the piston of the main cylinder, and with it the auxiliary slide D, has reached its bottom position, the outer face of C is open to exhaust through port E in the controller B. Steam pressure acting on the differential areas of C and C¹ now traverses the controller B upwards, and with it the main slide A, thus admitting steam to the lower side of the main piston. The position of B at the end of the up stroke is shown in the view to the right, in which the outer side of C is cut-off from the exhaust by the movement of D, which has opened port E to steam, thus causing the controller to move downwards. The cushioning of the controller is effected on the up stroke by cutting off the exhaust, and on the down stroke by an air dash pot F and adjustable snifting valve G. The movement of the auxiliary slide D, as in other gears of this class, is effected by direct connection with the pump-rod through the lever M, the valve-rod, in addition to the nut S, being fitted with an eccentric pin J to facilitate

the exact adjustment necessary to obtain a complete stroke of the main piston in either direction.

The description of the Tangye general service pump (usually made horizontal), with the aid of the very practical view of the steam end shown by the section, Fig. 104, is very easily made. The main distributing valve D controls the admission of steam to and exhaust from the cylinder A through portways of ordinary form. The valve chest B is bored out to serve as subsidiary cylinders L for the shuttle pistons C, which embrace a projection extending up from

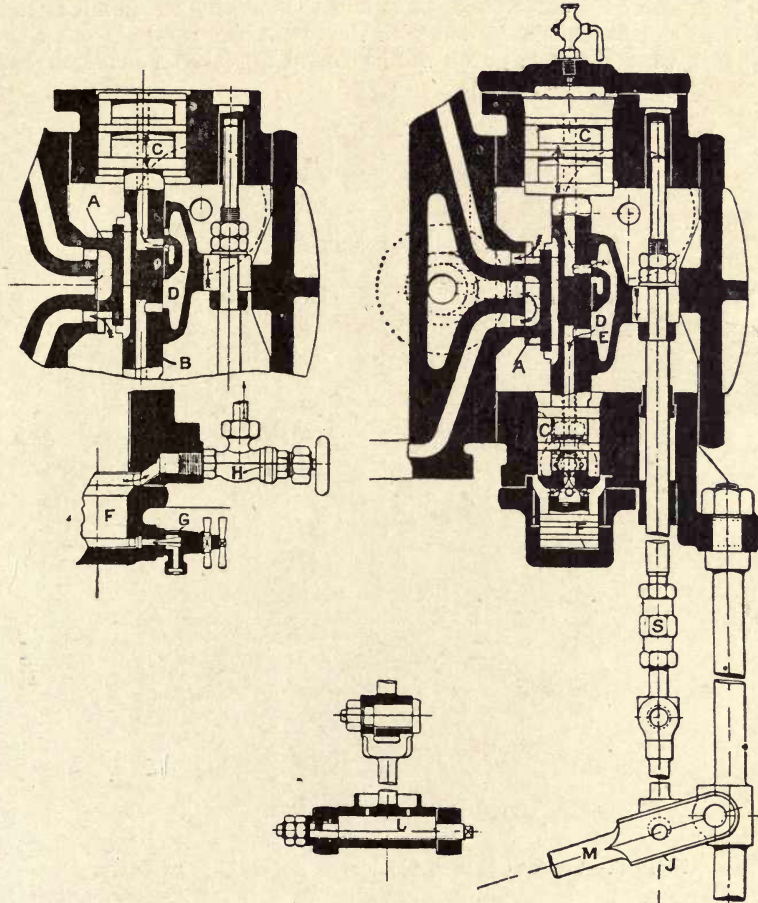

Fig. 103.—Differential Valve Gear used in the Storey Direct-acting Simplex Pump.

the back of the valve D by means of a stirrup connecting piece. Steam under pressure in the chest B is permitted access to the two ends of the shuttle C by means of small passages communicating therewith, and capable of being adjusted by the screw plugs K, thus steam normally maintains the shuttle in equilibrium. The outer ends of the subsidiary cylinders L are connected to the ends of the main cylinder A by pipes J. From these pipes, communication to the cylinder A is controlled by tappet valves F held down to seats E by

springs, the action of the pump being as follows:—Assuming that the shuttle C is moved to the position shown by the starting lever H, thus placing the pump end of the steam cylinder in communication with the central exhaust port, and the out end with the steam chest B, the main piston will be forced from right to left. When just on nearing the end of the in stroke, the bevelled edge of the main piston will strike the stem of one of the tappets F, and lift this valve off its seat, thus opening the subsidiary cylinder L at one end to the exhaust outlet *via* the exhaust port in the main valve D. By this movement the shuttle pistons C will be thrown over, say from right to left, thus placing the pump end of the steam cylinder into communication with the steam chest and the outer end to the exhaust, when the main piston will be caused to make an out stroke, at the

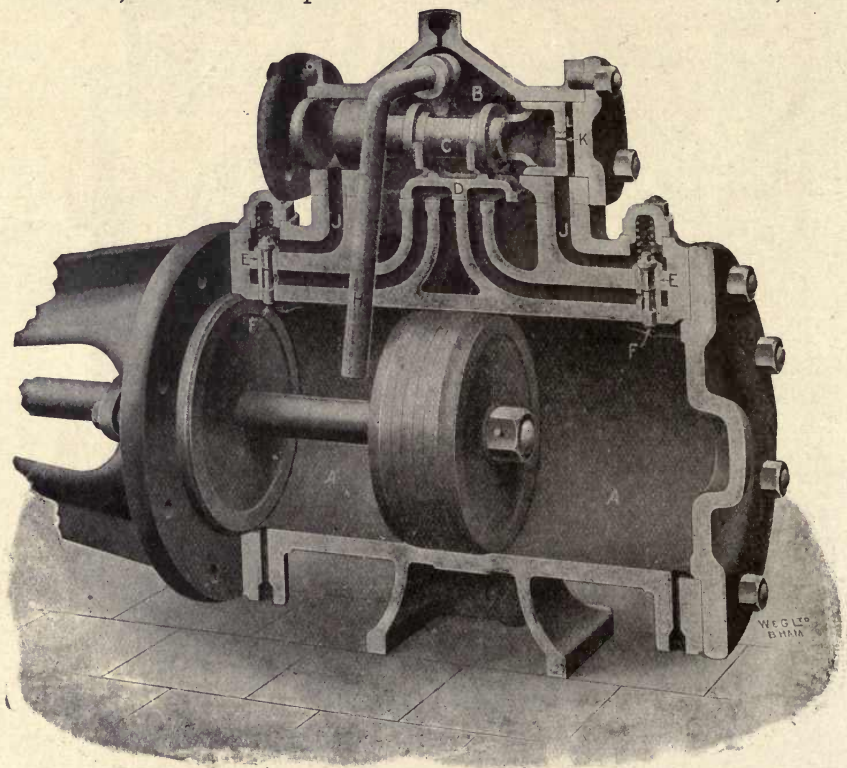

Fig. 104.—Section of Steam Cylinder of Tangye Simplex Pump.

completion of which a like effect will take place on the tappet at the other end of the cylinder, thus again reversing the movement of the main piston. It may be remarked in connection with this gear that the cushioning effect on the action of the pump will be influenced by the extent at which the tappet stems project into the cylinder; thus, unless means be provided for correcting the mistiming caused by wear, the action of the distributing valve will be tardy and the main piston liable to strike against the cylinder ends. However, it is not a serious matter by any means to substitute new tappets when such shall be necessary, seeing that the only parts of the pump to be dismantled for making this slight repair are the two auxiliary exhaust connections.

Voit's direct-acting simplex pump, illustrated at Figs. 105 and 106, differs from all others yet described in being constructed with an internally gland-

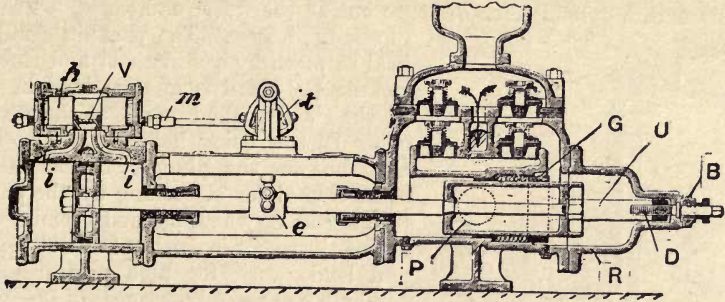

Fig. 105.—Simplex Pump with Gland-packed Plunger

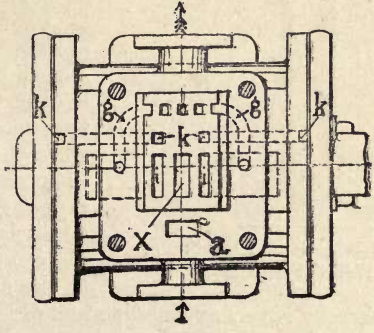
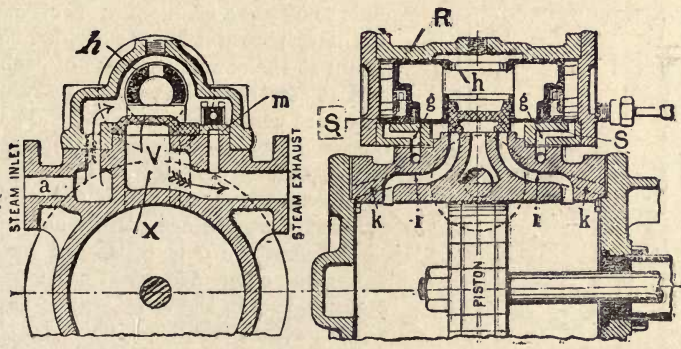
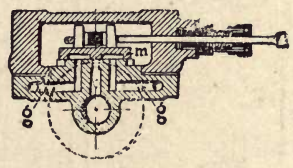

Fig. 106.—Valve Gear Details of Voit Pump.

packed water plunger P, which is made so as to be capable of being adjusted from the outside while working. As shown by the sectional arrangement, this pump is better adapted for the horizontal form, as the necessary parts used in this construction extend some distance out at the water end, owing to the use

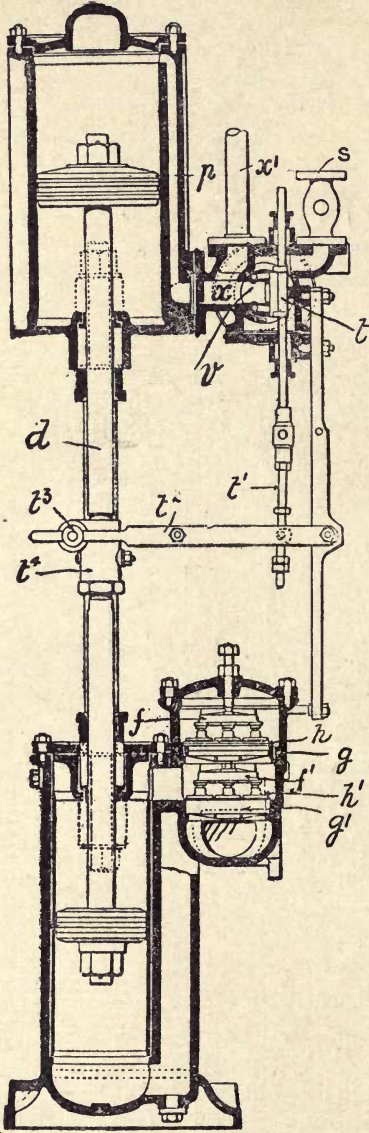

Fig. 107.—Sectional Elevation of
"Weir" Feed Pump.

of a long plunger. The packing gland G is held in place by a stirrup U and threaded spindle D, which is in turn held in place by the gland-packed box B, at the rear end cover R, this being hollowed out to allow clearance for the plunger P and the two arms U used for tightening up the plunger packing at G, which method permits of an even adjustment in a very practical manner, and lends itself for high pressures, thus combining the advantages of a piston plunger with that of an outside-packed ram plunger. In connection with the steam end there are some points of interest, although following in the main very closely to the lines adopted in other pumps of this class, the descriptions of which are shown by the detailed sectional drawings at Fig. 106, as follows:—The steam cylinder is provided with steam and exhaust ports (*i*), connecting with the cylinder some distance in from the ends to obtain a cushioning effect, other two auxiliary ports (*k*) being provided to admit steam at the commencement of each stroke and at starting. These two pairs of portways are controlled by a flat slide valve V operated by a double shuttle (*h*), working in the subsidiary cylinder R, forming part of the steam chest, to which the steam and exhaust passages are plainly shown. The piston shuttle (*h*) is controlled by a pilot valve (*m*) connected up to the pump-rod crosshead (*e*) in the usual way. This valve admits steam from the chest to the subsidiary cylinder by the auxiliary portways (*g*), which, as in the case of the main cylinder, are situated slightly within so as to obtain a cushioning effect on the shuttle, the piston ends of this being provided with slippers S to form a steam-tight fit over (*g*). In action, when the main piston approaches the end of its stroke to the right or left, it causes the tappet gear (*t*) to move the pilot (*m*), thus admitting steam through (*g*) behind shuttle plunger (*h*), and causing same to be traversed to the opposite end, and with it the main

valve V, thereby reversing the direction of the main piston.

The illustration (Fig. 107) represents the Weir boiler-feed and general service

pump, by an examination of which it will be seen that this pump differs in no very important degree from others already described, the most notable differentiation being found in the valve gear. Referring to the cut showing a cross-section of the distributing valve, (*s*) is the steam inlet and (*x*¹) the exhaust outlet, the distribution being by a double piston or cylindrical valve (*v*), the endways movement of which is controlled by a pilot slide valve (*t*), receiving motion from the rod (*t*¹), lever (*t*²), pin (*t*³), sleeve (*t*⁴), and pump rod (*d*). The pilot valve, by a vertical movement against a flattened face at the back of the main valve—which is formed with auxiliary ports communicating with the outer ends of the subsidiary cylinders—causes the main valve to be thrown back and forward across two steam ports (*p*), communicating with the main steam cylinder, and a third port (*x*), communicating with the exhaust outlet (*x*¹), the central portion of the double piston shuttle (*v*) thus serving as a circular slide distributing valve for the main cylinder on one side, and as a valve face for the flat slide valve (*t*) at the back acting as a pilot. In this valve gear it is not evident in what manner compensation for wear of the main valve against the cylinder face is to be effected, unless the circular distributing valve is so far separate from the two pistons acting as a traversing shuttle as to allow the circular valve a cross movement independent of the end pistons. However, since there are a great number of these pumps in successful use, including the British Navy, the drawback, if any, arising from this cause cannot influence its working to a great extent, and in all probability has been suitably provided for, as the makers have had a longer experience with the working of this class of pump than any other, and in evidence of the keen attention to detail, a Rochester mechanical feeder is used to supply just the necessary amount of lubrication to ensure the best results. In regard to the water end of the pump, it will be seen that the valves are arranged in groups of three (*h*, *h'*), in detachable seatings (*g*, *g'*), the lift of which is determined by stop frames (*f*); also that two sets of suction and delivery valves are provided, together with duplicate delivery flanges, arranged one at each side of the pump.

The action of the Wilson-Snyder simplex pump steam-thrown valve is automatic, balanced, and (is claimed to be) adaptable for a greater range of plunger speeds than can be obtained in any direct-acting simplex pump having a part mechanically controlled distribution, and, as will be gathered from the three sectional views (Fig. 108), there are three valves, the main valve consisting of four pistons (*A*¹, *A*², *A*³, *A*⁴), and is shown in two positions, one to the right of the steam chest and the other to the left; the *modus operandi* is as follows:—Just before the completion of the stroke of the main piston *B* to the right, it uncovers a port *C*², which leads to the space between the main valve piston *A*⁴ and the auxiliary piston valve *A*⁶, thus causing the main valve to move to the left, thereby opening the main steam port *D*¹ to the exhaust, and the main port *D*² to steam pressure, and at the same moment uncovering in the auxiliary valve stem *A*⁷ a small port *A*⁸ to the exhaust, and a small port *A*⁹ to steam pressure, thus allowing live steam to pass through port *A*¹⁰ in the auxiliary stem, to between the piston *A*⁶ and the steam chest cover *E*, thereby causing the pistons *A*⁵ and *A*⁶ to move in unison with the main valve to the left, and to cover port *C*² and uncover port *C*¹ at the left end of the cylinder; the valve is then in position to be reversed, when the main piston *B* has travelled to the left end of the cylinder and uncovered port *C*¹ to steam pressure. In Fig. 108*a* this form of distributing valve is shown adapted to a horizontal pump of the general service type, but specially constructed for lifting tar, creosote, and other liquids of a viscous consistency.

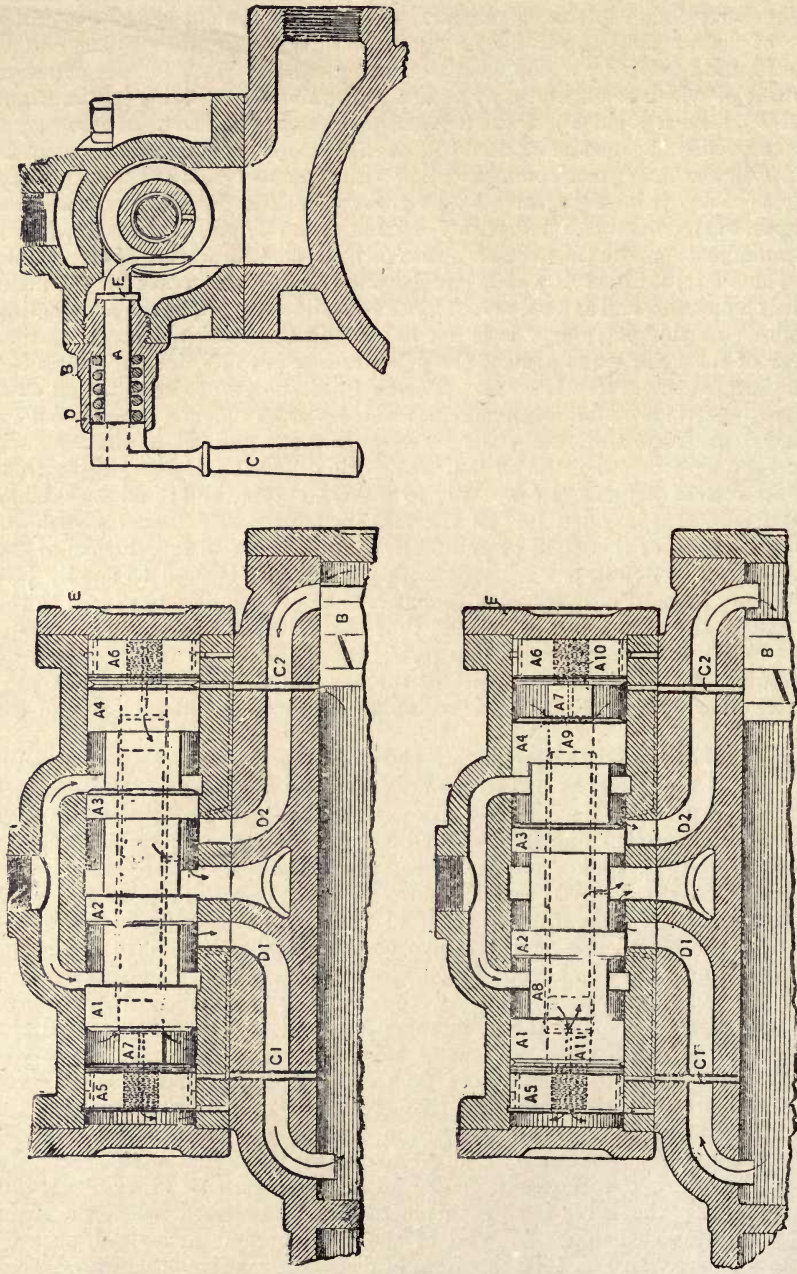

Fig. 108.—Sections showing details of "Wilson-Snyder" Automatic Steam Valve for Horizontal Simplex General Service Pumps,

In addition to the foregoing examples of simplex pumps of this class there are several others—viz., the Friedenthal, the Kingston, the Hall, Mather & Platt, Mumford, and such others of American and Continental manufacture as the Dean, Smith-Vaile, Mason, and Wheeler, etc. As, however, all these are constructed on lines more or less closely resembling pumps already described, to set each of these out *in extenso* would serve no adequately useful purpose.

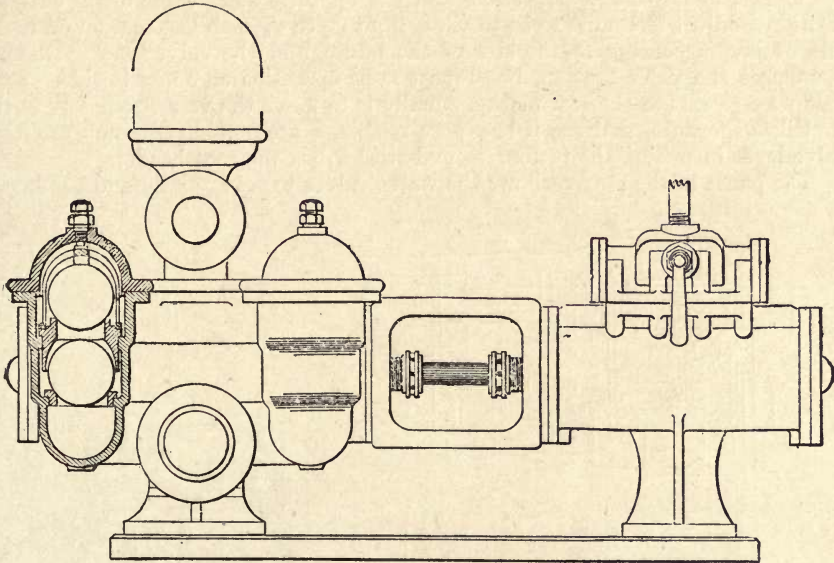

Fig. 108a.—Part Sectional Elevation of "Wilson-Snyder" Direct-Acting Creosote Pump.

Duplex Pumps.

This class of pump having already been described in connection with water supply stations, it will not be necessary to again enter into the principle of its general construction. As, however, pumps of the ordinary duplex type—*i.e.*, those fitted with slide valves operated in the direct manner introduced by Henry Worthington some 50 years ago, continue to be very extensively used, makers in general seemingly being satisfied with the construction and working as obtained in its original form—a few remarks as to the particular form followed in their application to general service work will not be out of place. Referring to Fig. 109, which represents a sectional view showing the more salient features, it will be seen there are five ports to the steam cylinder—the pump comprising two steam and two water ends—the outer pair serving as steam ports and the inner pair as exhaust ports, while the centre port communicates with the exhaust outlet. The five ports are controlled by one flat slide valve operated in a direct manner from the crosshead of the duplicate pump alongside, the connection being through a swinging arm as shown. In this class of pump there is a certain amount of slack between the collars on the rod and the lug at the back of the valve, and thus a certain amount of lost motion or pause in the valve at each stroke, which applies, of course, to both sides equally; and as they continue in such universal use, a few notes on the setting of the steam valve may be useful, seeing that duplex in common with all other pumps require an occasional overhaul.

Hence, (1) when the slide is connected to a rod having a collar and one nut, place one piston in the middle of its stroke and disconnect the link from head of valve-rod on opposite side, then set the valve in its central position, place valve nut evenly between jaws on back of valve, adjust rod until the eye on rod comes into line with the eye on rod link, then reconnect.

And (2), when the slide valve rod has double lock-nuts, place one piston in the middle of its stroke, as before, and the opposite slide valve in the central position; adjust lock-nuts so as to allow from $\frac{5}{16}$ to $\frac{3}{16}$ inch lost motion on each side of jaw, according to the size of the pump, and the valve is set. Do not disconnect the valve motion, but repeat same operation on opposite side. The best way to divide the lost motion equally is to move the valve each way until it strikes the nuts, and see if the port openings are equal. Do not use the valve lever in prising the pistons to mid-stroke, but the crosshead.

The pause in the stroke allows the water valves to seat quietly and conduces

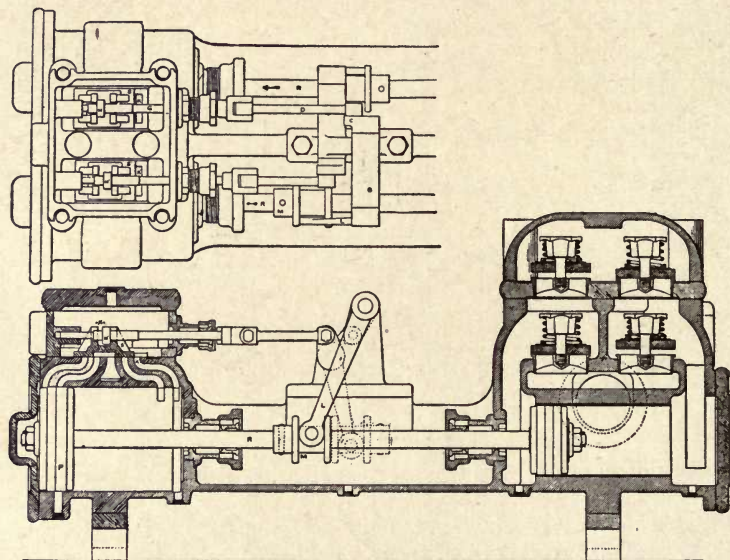

Fig. 109.—Deane General Service Pump, showing Worthington Duplex Valve Traversing Action.

greatly to the smoothness of working, which has led to this form of pump to be so largely adopted. Duplex pumps are, however, not free from objections—*e.g.*, as the valves have little or no lap there is no appreciable expansion—and, further, the double set of ports at each end of the cylinder makes the clearance excessive—a defect which can be very materially emphasised by the pump valve gear getting out of adjustment, so causing the pump to work with an uneven and reduced stroke, although resulting in reduced travel and wear of valve. The liability of duplex pumps to a variable stroke has induced many makers to adopt a crank motion, but it is questionable if the economy to be gained by this means if steam driven repays the extra expense of steam. However, crank-driven duplex pumps have much to commend their use when belt, gear, or directly driven from a gas or oil engine or electric motor, in which case the full advantage of a uniform flow is obtained in the delivery.

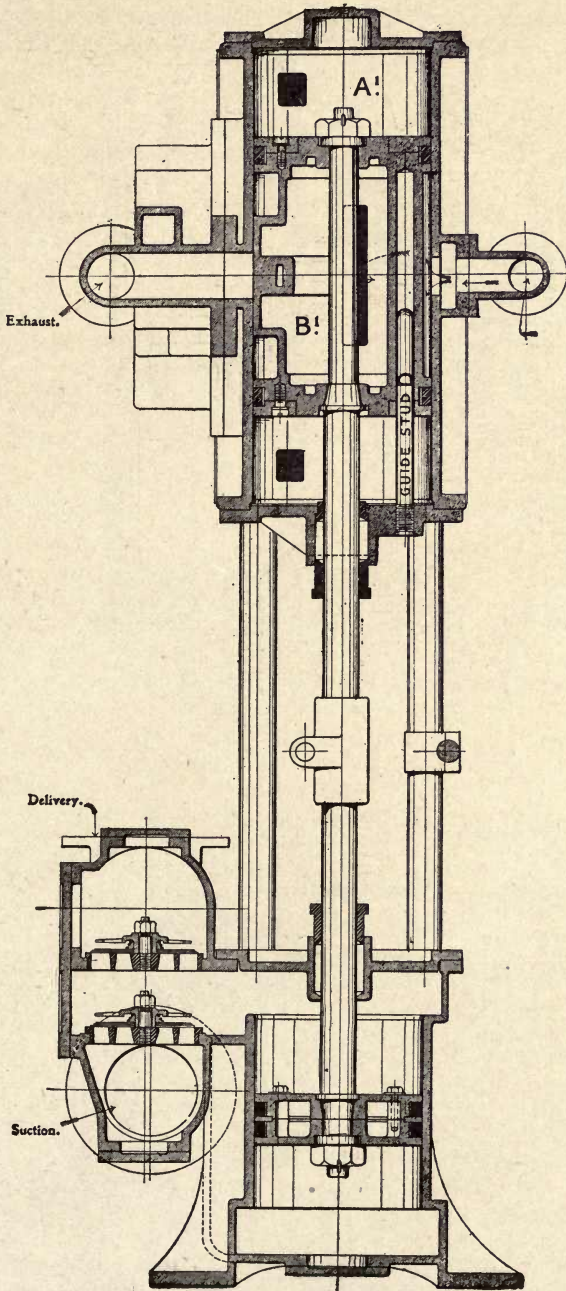

Fig. 110.—Cross-section of Mumford Valveless Duplex Feed Pumps.

Many attempts have been made in the construction of direct-acting duplex pumps capable of working without the 5-port valve gear, the most notable

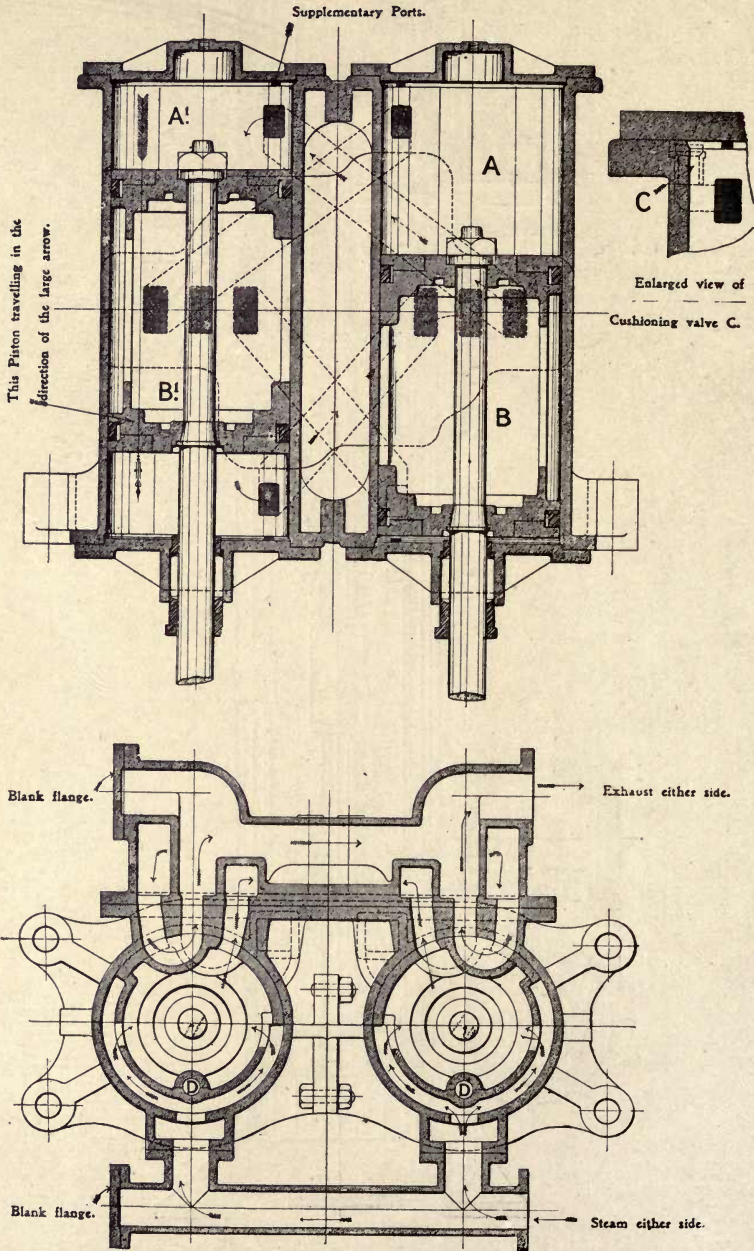

Fig. 110a.—Sectional Elevation and Plan of Steam Cylinders of Mumford Valveless Feed Pump.

success being obtained in the pumping engines using the Corliss type of valve gear. For general service work, however, the endeavour has been more towards the simplification of the pump, and to this end valves have been entirely eliminated in both steam and water ends—*e.g.*, the Clarke-Dowson duplex pump, which is more particularly adapted for ballast work and other applications where pumps fitted with ordinary lift valves are liable to get choked up; the special feature about this pump, known also as the Clarke-Chapman Valveless Duplex, consists of a special formation of the pistons and plungers, so adapting them to serve as a slide valve to the steam cylinder or pump barrel next it, thus dispensing with all other steam or water valves entirely.

The peculiarity in duplex pumps of the "valveless" type is clearly illustrated by the following description, and representative illustrations, Figs. 110 and 110*a*, of the Anthony-Mumford duplex pump. In this example the steam cylinders only are made "valveless," the water end being of the ordinary construction, and adapted as a boiler-feed pump, although obviously adaptable to many other purposes. Referring now to the steam end, we find that the cylinders are made more than twice the length of the stroke, to enable pistons to be used long enough so as not to pass the intercommunicating portways in the centre of the cylinders. At one side of the bore of each cylinder, and situated in the middle of its length, is an ordinary 3-port valve face, the middle ports being the exhaust as usual, and lead to an exhaust pipe in front of the cylinders; the two outer ports in each cylinder are for steam, and lead to the two ends respectively of the adjacent cylinders, as shown by the dotted lines in the elevation, Fig. 110. Steam is admitted by the pipe shown in the plan and in Fig. 110*a*, and enters as indicated by the arrows through openings in the middle of each cylinder, and passes directly into the hollow pistons.

As before explained, duplex pumps fitted with the ordinary construction of cross-over valve gear do not admit of an appreciable degree of expansive action, this fault, however, has been remedied to a certain extent in a form of pump known as the Differential Duplex, in which, as can be gathered from the illustration, Fig. 111, the valves D, E, instead of being actuated each from the pump-rod crosshead on the opposite side, as in Fig. 109, are in this pump traversed by a floating beam B connected at two points G, H to rocker shafts T, T¹, which in turn are connected to the two pump-rod crossheads by the rocker levers A, A¹, which by this means impart to the valves a compound or differential movement derived from the motion of both piston-rods, and to impart to each valve an advance opening or lead, as well as a cut-off between $\frac{3}{4}$ and $\frac{1}{2}$ stroke, thus enabling the pump to be run, not only at a higher speed, but with a considerable economy. As in the ordinary duplex, a certain amount of lost motion is allowed at the connections to the valve rods, and is obtained in this pump by sliding blocks on the beam B working between adjustable clamps F. A peculiar feature in the working of pumps controlled on this system is their tendency to run with an equable stroke even after hard and continuous service, which may be attributed to the compound movement, as each piston-rod in part governs its own valve as well as that of the other cylinder.

In the Fielding single-valve duplex pump illustrated by the three sectional views, Fig. 112, an improvement has been made in another direction—*viz.*, in the reduction of the number of parts subjected to motion, wear, and misadjustment. In this pump (which, by the way, was first introduced some years ago) this end has been attained by adopting a combined oscillating and reciprocating slide valve (*v*) working on a radial valve face having five ports only for the two cylinders, of which the two ports (*r*) communicate with the cylinder R, and

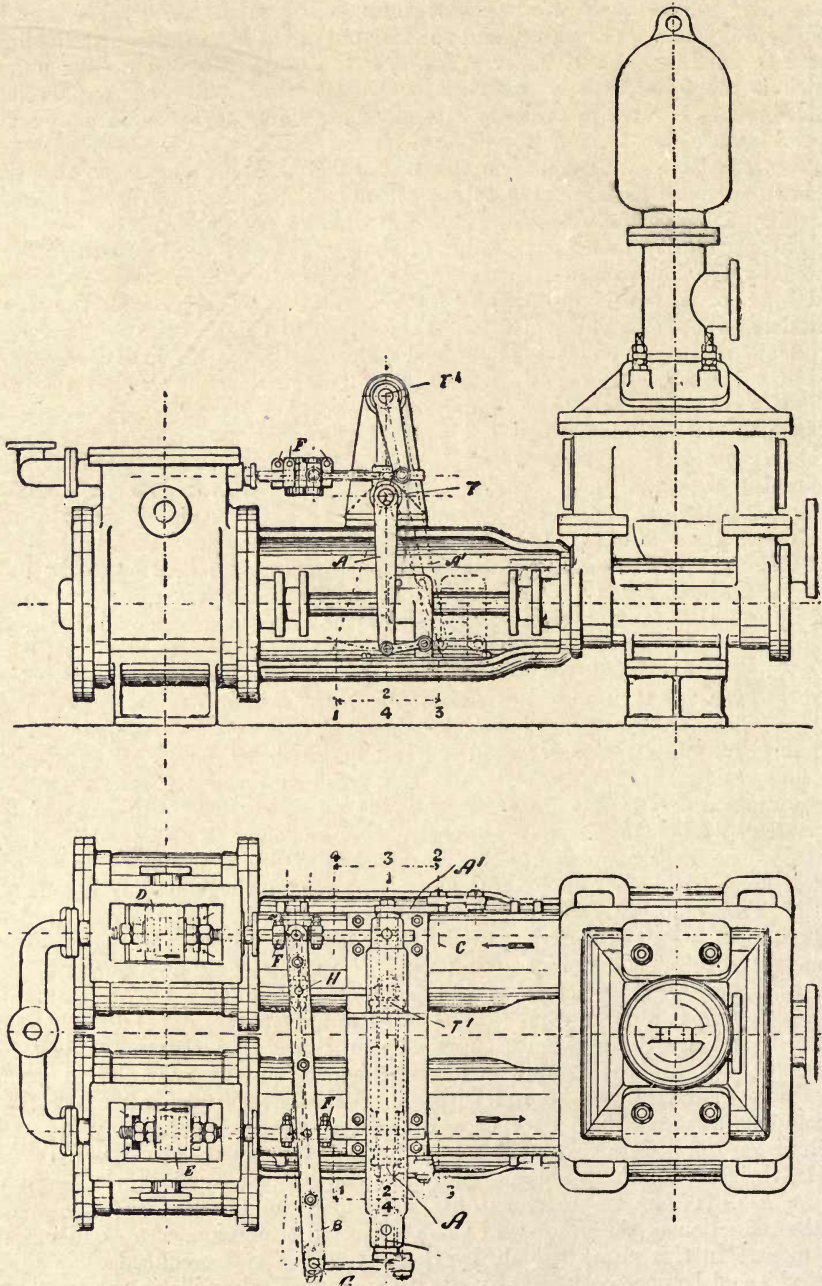

Fig. 111.—Duplex Pump, with Beaver Differential Steam Control.

are placed into communication with steam pressure supplied at (*s*), and with the exhaust outlet (*x*) by a reciprocating movement derived from the pump-rod of the opposite cylinder *L*; the distribution to the left-hand cylinder is effected by imparting to this valve an intermittent oscillatory movement from the right-hand pump-rod, the valve in this manner being caused to open the two ports (*l*) alternately to steam pressure and exhaust. By this construction, it will be seen that the total number of steam ways is reduced from 12 to 7, and the number of loose parts constituting the valve gear from 20 to 12; on the other hand, the cushioning effect obtained by the use of separate steam and exhaust ports, as in the ordinary duplex, cannot be adopted by this method with advantage.

The latest improvement in this direction forms an important feature in the Oddesse duplex pump, in which external loose parts have been totally done away with, and the pump in its simplest form is so far reduced in complexity as to only require eight steam ways and four moving parts constituting the loose connections used for the valve gear of both cylinders. In the Oddesse pump the distributing valves, instead of being traversed in the direction of the pistons, as in the ordinary duplex, are moved across the cylinders, *vide* the sectional views, Fig. 113, their motion being derived from two reciprocating diagonally-slotted blocks (*b*), which are positively connected through the rods (*d*) with the two piston-rods below, the slide valves (*v*) being each actuated from the opposite side by short rods (*i*) connecting to the bearing snugs (*k*). In action, as the two slotted blocks (*b*) move to and fro in their seatings, they impart a transverse motion to the two crosshead bearing snugs (*k*), this cross movement being transmitted to the two slides (*v*) by the short transverse rods shown, these being arranged in duplex fashion, so that the right-hand block works the left-hand valve, and *vice versa*. A great feature with this simple construction of steam distributing gear is its adaptability for expansive working, either by slides working over the main slides, and arranged to be adjusted by a screw, as in the Mehr cut-off gear, or by rotatable piston valves, as shown, the former method being used for single expansion, and the latter for double expansion. In the compound pump a variable cut-off is thus obtained by balanced piston expansion

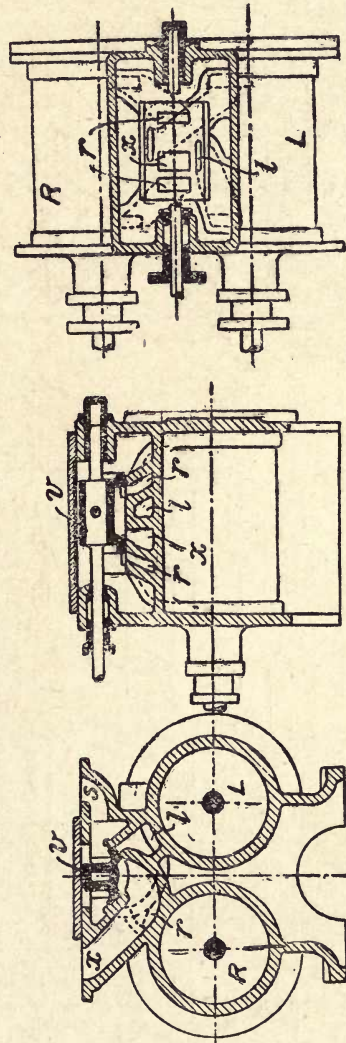

Fig. 112.—Steam Cylinders of Fielding & Platt Duplex Pump, with Combined Oscillating and Reciprocating Valve.

valves (*x*), arranged to work in auxiliary reciprocating cylinders (*e*) forming part of the main slides (*v*), within which each expansion piston (*x*) receives, through

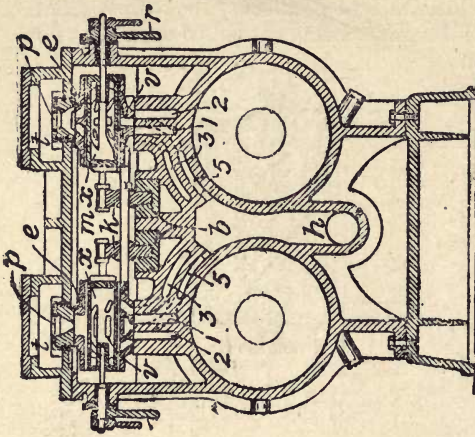
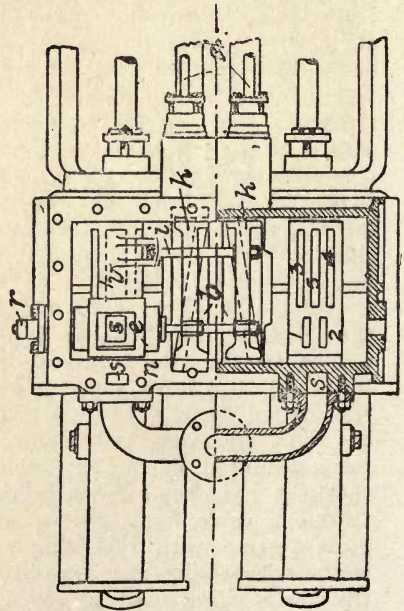
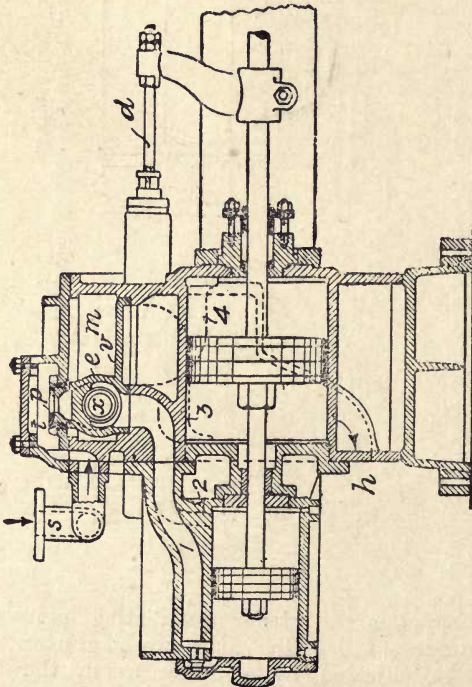

Fig. 113.—Sectional Elevations, showing Steam Cylinders of "Odessa" Compound Duplex Pump.



short rods (*n*), a lateral motion from the bearing snug (*k*) immediately next each to it; in this manner the expansion valves are moved independently, and as these

are provided with vee-shaped ports, the degree of cut-off can be conveniently varied while in motion by turning each on its axis by the adjustments (*r*) arranged outside the cylinders.

When constructed to work compound, as shown in the section, the exhaust steam from the high-pressure cylinders is discharged into the common receiver (*m*), which forms the steam chest for the two low-pressure cylinders, whence these draw their supply of steam in the ordinary manner. To permit of this being done (the high-pressure steam having to be kept out of the low-pressure receiver) the high-pressure steam is conducted from the supply pipe (*s*) into two small high-pressure chests (*t*), whence the steam flows through the plates (*p*) direct into the two expansion valves (*x*) through the openings (*s*). By means of these diaphragm plates leakage of high-pressure steam into the receiver below is prevented, as the plates bear against the auxiliary expansion casings (*e*) by steam pressure from the chests (*t*), and are each capable of independent adjustment for wear.

It may be pointed out that the expansion valves (*x*) receive no motion from the outside except that of an oscillatory adjustment by means of the hand lever (*r*), in consequence of which there are practically no glands exposed to the high-pressure supply, the arrangement of the steam ports being as indicated by the figures; thus the two high-pressure ports (1) and (2) are controlled by the underside of the valve casing (*e*), by which steam is distributed to the high-pressure cylinder on each side of the pump for a portion of the stroke, determined by the radial adjustment of the expansion pistons (*x*), and is exhausted direct into the common receiver (*m*), whence the steam is distributed by the slides (*v*) to the ports (3) and (4) into the low-pressure cylinders, and finally exhausted through ports (5) to the outlet at (*h*).

In regard to the particular distribution used in the Oddesse pump, although it cannot be gainsaid that the number of wearing parts in the ingeniously designed valve gear is very materially reduced, there is obviously no reduction in valve friction or surface wear, the weak feature of the gear being undoubtedly the long travel of the diagonally-slotted traversing blocks (*b*) against the resistance opposed by unbalanced distributing valves. Recognising that the bearings of this gear are exposed to conditions of imperfect lubrication, in other respects it would seem to be all that is claimed for it.

There is a slightly modified arrangement of valve gear used in the Prescott duplex pump, as shown in section by Fig. 114. In this pump the steam is continued for practically the full stroke in both high and low-pressure cylinders, the ratio of expansion working out at about 5.5 to 1 including clearances. The usual lost motion between the valve-rods (*d*) and the driving connections (*e*) is obtained by adjustable blocks (*b*), the rods being firmly secured to the valves endways, which results in the adaptability for a more exact adjustment of port opening and in reduced wear; there is no reduction, however, in the number of loose connections used for actuating the valves.

The 5-port construction is used for the low-pressure cylinder only, this affording the required cushioning effect for high speeds, and has the merit of reducing clearance in the high-pressure cylinder. This illustration also shows the usual construction followed in double ram pressure outside packed pumps with side-rods (*p*), which, together with the six piston-rods, are connected to the four ram plungers by two pairs of crossheads (*h*), the pair at the pump end being supported by a slipper bearing. In Fig. 115 is shown a standard design of inside packed ram-plunger pressure duplex pump, having a single pair of plunger rams (*m*) removable from the end, and is a construction that has the advantage

over outside-packed plungers in requiring less length of floor space; but, *per contra*, the glands are less accessible and rendered still more so by the necessary

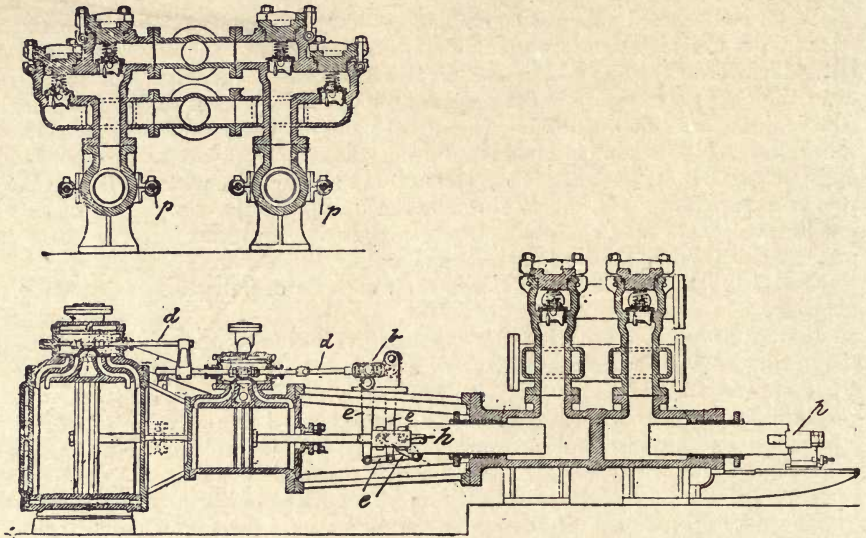

Fig. 114.—Sectional Elevations of "Prescott" Direct-acting Compound-pressure Pump.

stay bolts (*t*), there is also the area of the pump-rod to be taken into consideration, which, although of little significance for low pressures, is decidedly against this form of pump for pressures used in hydraulic practice. However, when com-

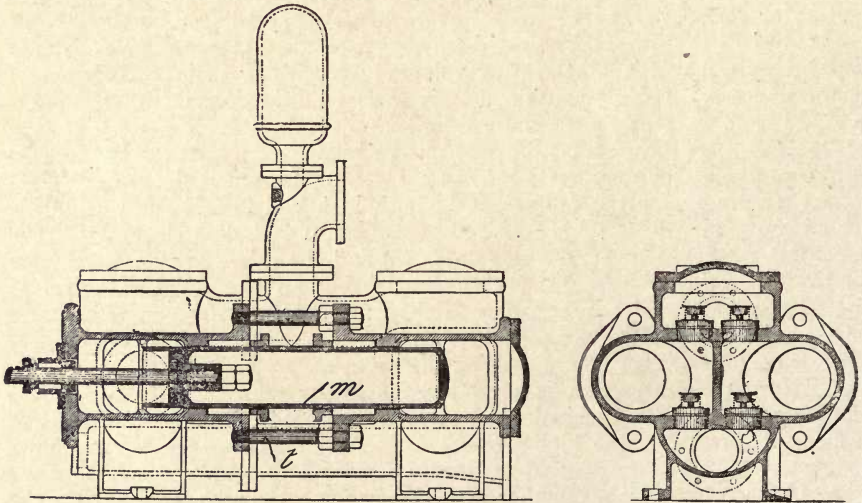

Fig. 115.—Water End of Epping-Carpenter Duplex Pump, with Inside-packed Ram Plungers.

bined with the additional advantages rendered possible by the Heisler construction, illustrated in Fig. 116—viz., with the stay bolts (*t*) spanning the water space,

and the plungers (*m*) surrounded by water-sealed glands (*g*), there is much to be said for the inside packed plunger design, the more so that one gland takes the place of two, and air excluded; and further, owing to its length, the gland can be more evenly held up to its work, and plunger friction reduced; the cost

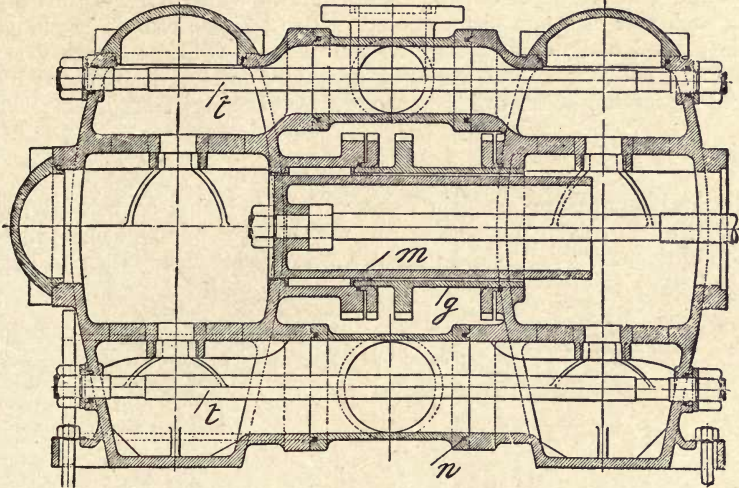

Fig. 116.—Section of Heisler Duplex Pressure Pump, with Water-sealed Inside-packed Plunger.

for packing renewals, moreover, is naturally halved, and by the exclusion of air from the pulsating chambers, water hammer largely prevented.

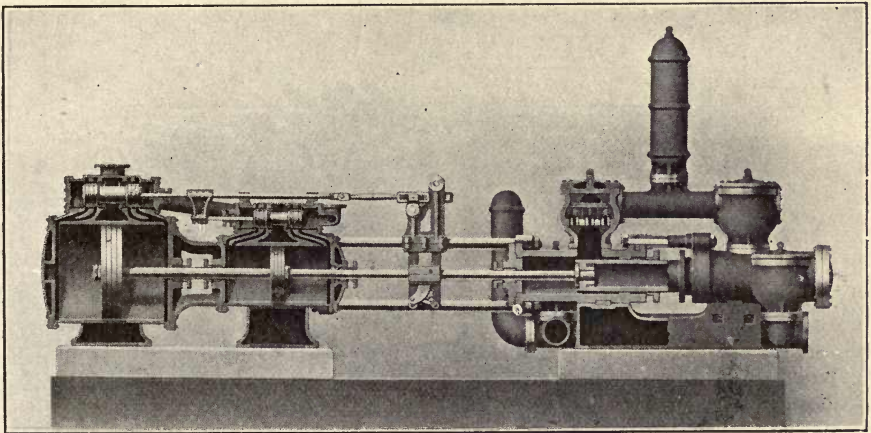

Fig. 117.—Sectional Elevation of "Wilson-Snyder" Compound Duplex 25" x 42" x 9½" x 30" Oil Pump to deliver one million gallons per 24 hours against an average pressure of 1000 lbs.

The duplex form of pump, owing to its equable action, was early recognised as being most suitable for pumping petroleum through long pipe lines, and in

point of fact it was due to its success in this particular adaptation that first brought the duplex pump into prominence in the States of America. A typical pump for this purpose is illustrated in Fig. 117, known as the "Wilson-Snyder," which is of the usual 5-port type, but fitted with piston valves operated on the lost motion principle from outside slotted blocks, as in Fig. 114, but differs in having each pair of steam pistons connected to a single rod. The plungers are outside packed and double-acting, as shown in Fig. 115, but are fitted with suction and delivery valves arranged in group form of larger capacity than required for forcing water, owing to the greater viscosity of crude petroleum.

Flywheel Pumps.

Flywheel pumps are made in great variety, whether as belt-driven, gear-driven, or direct-driven pumps, 3-throw ram plunger pumps being widely used on the Continent for boiler-feed purposes, and are arranged either to be steam-

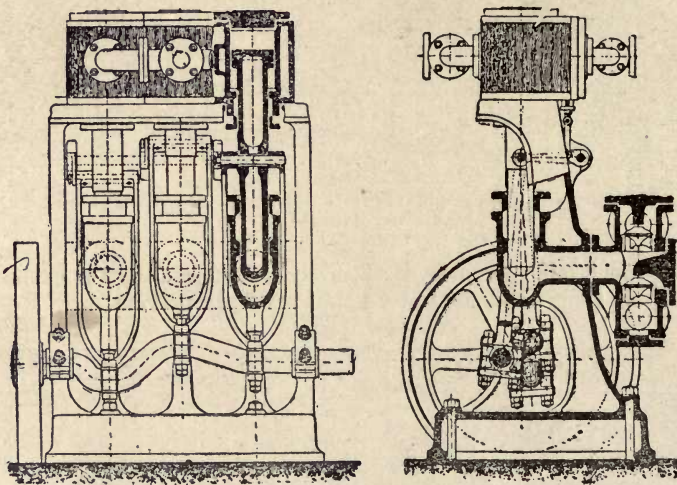

Fig. 118.—Yates and Thom Feed Pump.

driven by an out-end engine, belt-driven, or more generally gear-driven from an electric motor. A very compact form of steam-driven 3-throw pump is shown by Fig. 118, the crank shaft being below both pumps and steam cylinders. Trunk steam pistons cast in one piece with ram plungers are provided having crosshead connections midway between the steam and water ends, to which the ends of tuning-fork rods make direct connection with the cranks; the cylinders are each high-pressure, the full area of the cylinder diameters being utilised for the pressure stroke only, thus tending to equalise the action of the Yates and Thom pressure pump to a great degree.

Another form of flywheel general service and pressure pump is represented by Fig. 119. In this pump, known as the Cameron, the crank shaft is situated between the steam and water ends, the two steam pistons and water plungers being connected each by an open frame crosshead within which works a short connecting-rod on to an overhung crank, the shaft being provided with one mid-frame flywheel. This type of pump lends itself for compounding, and

when worked at normal speed can be worked expansively with a high economy ; but owing to the very short connecting-rod encompassed by the open frame crosshead, this form of pump in general use sooner or later develops considerable

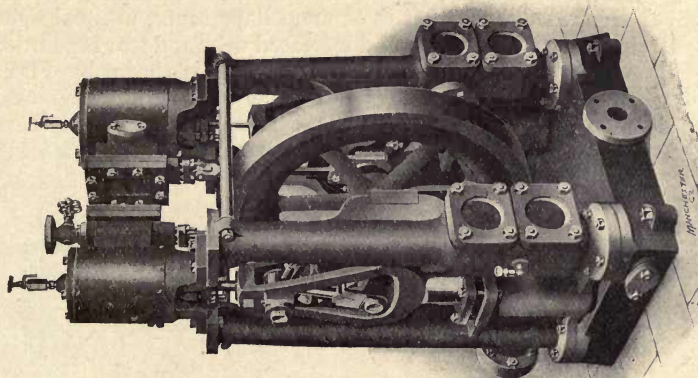

Fig. 119.—Compound Cameron Pump.

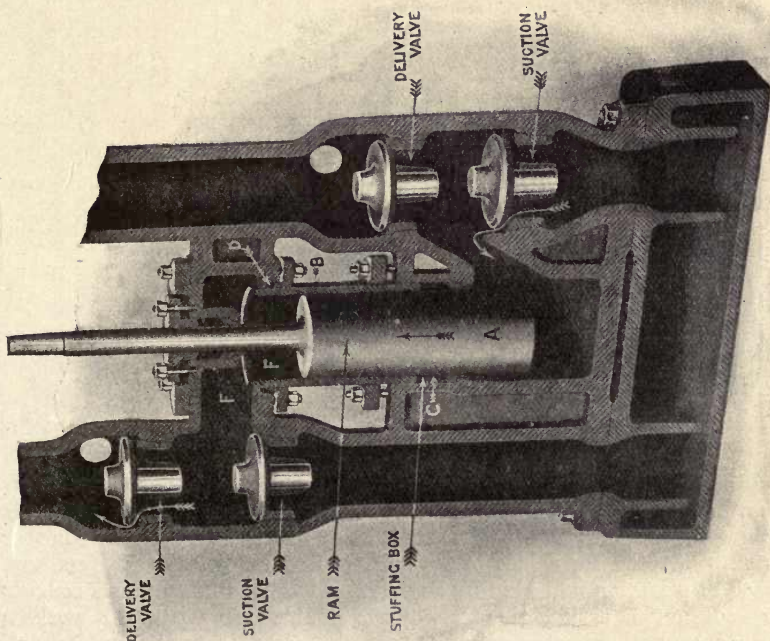
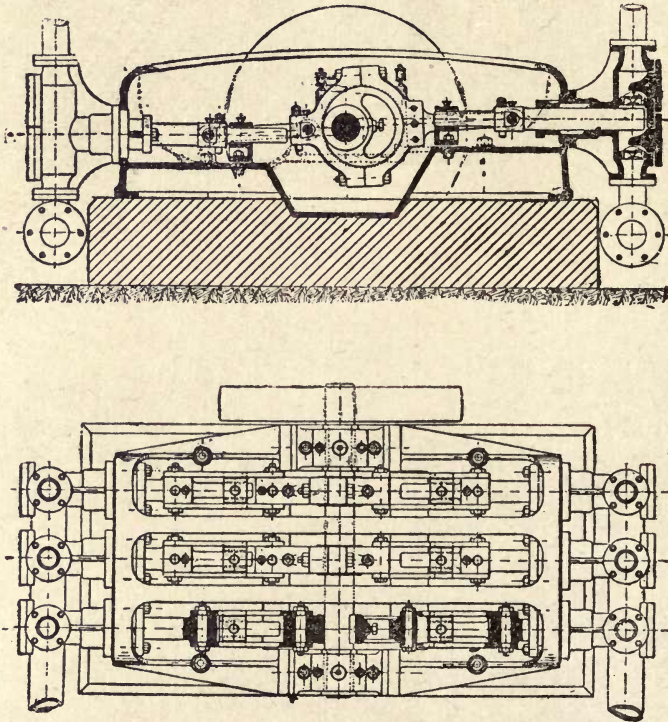

Fig. 120.—Section of Water End used in Pearn Double-acting Flywheel Pump.

knock. A sectional view of Pearn's double-acting pump, which may be used in combination with the Cameron drive or by side-rods, is represented by Fig. 120 ; the special feature about this pump consists in the method used for packing

the double-acting ram A, which is not only centre-packed, but obtains the advantage of an easily removable or renewable liner B; unequal pressure is also prevented from being applied to the gland C by reason of the gland being guided in the stuffing-box D. There is thus, it will be noted, only one gland for the plunger, by which means, not only is the operation of packing or adjusting the stuffing-box facilitated, but, what is of more importance, unequal tightening-up with a corresponding loss of power and increased wear and tear is guarded against.

A 3-throw ram plunger belt-driven feed pump is shown by Figs. 121 and 121a, duplicate sets of pumps being arranged at opposite sides of one shaft, and connected up to three ordinary eccentrics. In this arrangement there is practically a uniform torque on the shaft and uniform delivery at each set, the pump



Figs. 121 and 121a.—Three-throw Belt-driven Feed Pump.

being adapted for either feeding two separate boilers or one side can be used as a stand-by, and is a type of pump often arranged vertically with a single set of three plungers, the crank or eccentric shaft being belt or gear driven. Another form of pump adapted for a belt or gear drive, and known as the Hamilton, is illustrated in elevation and plan by Fig. 122, a feature in this pump consists in its very continuous action, there being two double-acting plungers working at 90° with one another; stop-valves (p) are also provided to the suction and delivery branches of each plunger, by which either side of the pump may be put out of action, either for continuous service or temporarily as may be occasioned by any derangement of the valves (v), thus enabling these to be examined without having to stop the pump.

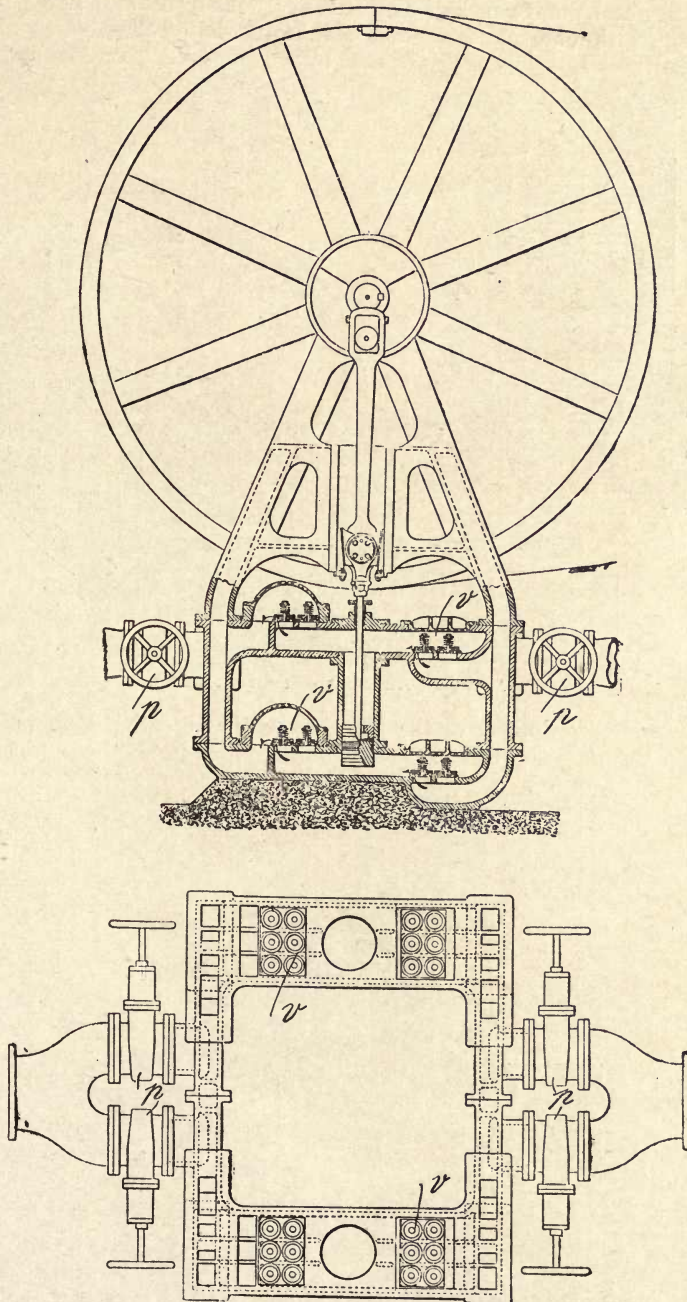

Fig. 122.—Sectional Elevation and Plan, showing the Hamilton Duplex General Service Flywheel Pump.

Other flywheel pumps include the ordinary donkey or wall single-cylinder steam pump, with loop connecting-rod, and crank shaft below both pump and steam cylinder. The loop rod is also used in a vertical single or double cylinder

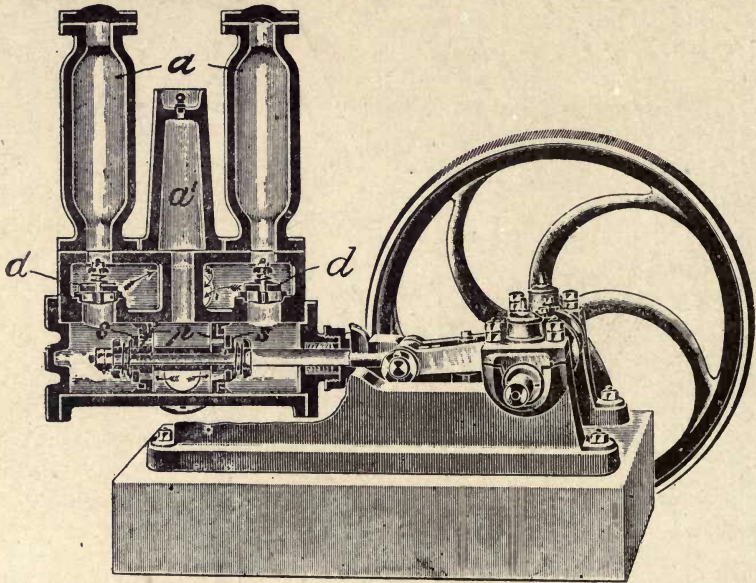

Fig. 123.—Baillet-Audemar Belt-driven Pump.

ram plunger pump, known as the Manchester, the essential difference in this pump and the Cameron consists in the use of a long loop connecting-rod, as

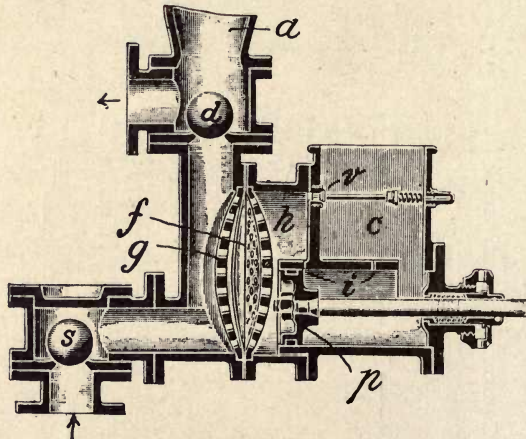

Fig. 123a.—Belt-driven Diaphragm Pump for Corrosive Liquids.

against a short rod worked within a loop crosshead, a construction in which the tendency is to cut down the length of connecting-rod below the smooth working limit in order to avoid the use of an open crosshead of excessive size.

A form of belt-driven pump is illustrated by Fig. 123, known as the "Baillet-Audemar," in which the foot valve is dispensed with, and is of a most unusual construction, although supplied in considerable number by the makers Les Forges de Dole et Foucherans, for a variety of purposes, both in the form shown and with two pairs of bucket plungers connected to a single crosshead, the pump barrels for both being open to one another, one pair of plungers having suction valves, and the other pair delivery valves. In the pump illustrated, which is double-acting, there are two plunger pistons (*p*), each provided with valves opening outwards from the space between, which is open to the suction pipe, the delivery valves acting in the ordinary way. In action, assuming the plungers to be moving to the right, the one at the driven end will then be displacing the contents drawn in through its valve during the previous stroke, and at the same time water will be drawn in to fill the space displaced behind the other plunger and will enter through its valve; air chambers (*a*, *a*¹) are provided on both connections to equalise the suction and delivery flow.

A detailed section of a belt-driven combined plunger and diaphragm displacement pump for corrosive liquids is also illustrated by Fig. 123*a*, in which the liquid pumped past the ball valves (*s*, *d*) is displaced by a rubber diaphragm (*f*), which is pulsated between grid seats (*g*) by the movement of a plunger (*p*) and water in the chamber (*h*). For maintaining the correct supply of water in the displacement chamber, two apertures (*i*) are provided, which are in turn uncovered by the plunger when nearing the end of its stroke each way, and as the cistern (*c*) is open to the front end of the plunger, the contents will rise and fall with its movement; a safety valve (*v*) is also provided to permit the escape of any surplus water from the space between the plunger and the diaphragm when required, as in starting.

CHAPTER XII.

INJECTORS, JET-PUMPS, AND EJECTORS.

ALL present-day forms of apparatus in which the kinetic energy of a steam, air, or water jet is utilised to induce a secondary flow are the outcome of Henri Giffard's invention, first patented in this country, July 23rd, 1858, the British rights for this new method of lifting and forcing water having been purchased by Messrs. Sharp, Stewart & Co., in 1859, who within a year of this date made their first application of the injector principle to a locomotive; when its action proved so astonishingly successful as to very quickly take the place of the plunger feed pumps then in use, and soon became the standard feed pump for locomotives in all parts of the world.

In the early days of railways the boilers of locomotives were supplied with water by means of force pumps worked by hand levers; afterwards the feed pumps were worked either by eccentrics direct from one of the axles, or by rods attached to the piston-rod crossheads. On some lines—*e.g.*, the London and South-Western Railway—an independent donkey pump was employed to feed the boiler, and down to quite recently engines on the London and Brighton Railway have been in some cases fed by a water pump worked in connection with the Westinghouse air-brake pump. Any form of independent feed pump in locomotive practice is an improvement on the directly-driven pump, and dispenses with the necessity at any time for running a locomotive backwards and forwards, or with tender brakes hard on in order to fill the boiler.

There was at first, as might be expected, considerable prejudice on the part of locomotive engineers to the use of the injector, and much difficulty was on this account experienced in getting the required permission for giving the new method a practical test; however, after some delay the firm above referred to succeeded in proving its adaptability for this purpose on a ballast engine belonging to the St. Helens Railway, its working being subsequently explained in a paper read before the Institution of Mechanical Engineers, by Mr. John Robinson—*i.e.*, in 1860. Needless to say, considerable astonishment and incredulity was evinced by many engineers to the apparently paradoxical action of the injector, which, with the possibilities held out for this very novel apparatus in the more economical working of the locomotive, brought this invention of Giffard's into the utmost prominence. Now, in addition to the original purpose of its application, apparatus variously modified, but all conforming to the principle of the jet pump, are used for feeding stationary boilers, filling engine tanks, etc.; for circulating lye in bleach keirs, for circulating water in gas holders to prevent freezing; as an exhauster for filling creosoting tanks, lifting tar, and other viscous or corrosive liquids; as an ejector for emptying bilge water, elevating sand or mud, in addition to which purposes the jet pump may be used to considerable effect as a fire extinguisher, and for lifting water generally, where expediency takes precedence of economy. Lastly may be mentioned its adaptability for priming centrifugal pumps, and as an exhaust-steam condenser

where water is plentiful; while as an air exhauster and for forced draught it has a wide range of recognised usefulness.

The Giffard boiler-feed injector, as made in its original form, and in a later form of injector known as the Mansfield (which only differs in a slight degree), consists of a steam nozzle (the sectional area of which, as shown by the illustration (Fig. 124), is capable of adjustment by a pin valve), a suction nozzle, and a delivery nozzle, the two latter together taking the form of a vena-contracta, of which the diameter of the throat of the delivery nozzle is usually taken as the unit of size. As shown, the steam nozzle is capable of adjustment endways to determine the water inlet area to the mouth of the suction cone; when used as a force pump, as in this case, a non-return valve is used to prevent back flow, the space between the two cones communicating with an overflow pipe for assisting to obtain the required velocity at starting to overcome the resistance due to boiler pressure. On the supply of steam being properly adjusted to suit the pressure and the water supply to the lift, the overflow ceases, the kinetic energy in the water jet then being sufficient to overcome the static head. When used as a non-lift injector, the above-mentioned three essential parts may each be of a fixed area, in which case the steam and water supplies may be controlled by ordinary stop valves.

A carefully - adjusted and well-proportioned injector can be made to lift cold water from 20 to 24 feet, but will not lift boiling water, although water of a temperature of 140° F. can be raised 6 feet or so under careful handling. When an injector is used to lift the water as well as to force it against the steam pressure, a plug is usually fitted in the steam nozzle to regulate the area of the supply at starting, the several examples appended indicating the various methods adopted by different makers to ensure (1) certainty and continuity of action under conditions obtaining in a locomotive, such as caused by jolting, vibration, etc.;

(2) accessibility of the several cones for easy removal for cleaning; (3) simple single movement control of steam and water supplies. It will be seen that in most makes that re-starting injectors—*i.e.*, those capable of automatically

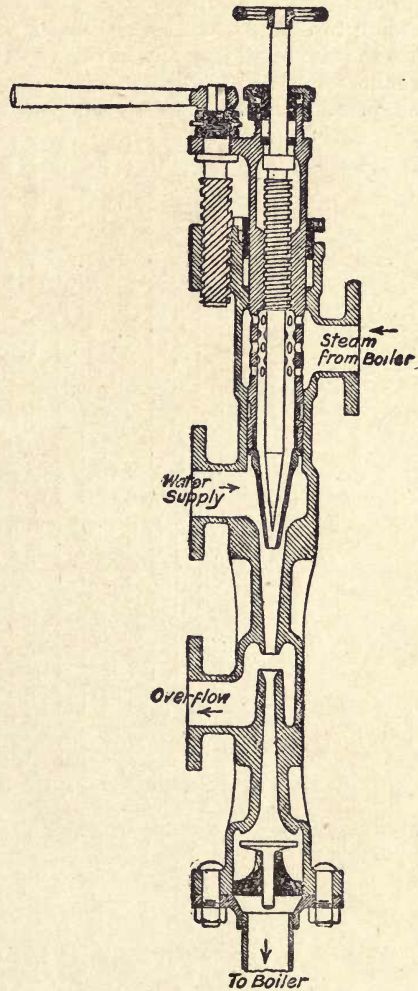

Fig. 124.—Early Form of Giffard Boiler-feed Injector with Plug-controlled Sliding Steam Nozzle.

continuing in action after a momentary break in the water jet across the gap separating the suction from the delivery cone, are provided with non-return valves at the overflow, which, by-the-way, serves also to prevent induction of air, and thus to some extent increases the delivery as well as for the purpose of assisting in the starting action, and for the maintenance of an unbroken jet.

Injectors are constructed for either live steam or exhaust, and also for both in combination. In the treatment of this subject, for the sake of simplicity and clearness of exposition, each class will be taken *seriatim*; but before proceeding to describe the several types of live steam injectors, it may be stated that the size of all injectors of this class is expressed in terms of throat diameter in millimetres, the following formulæ being used in computing the size, volume, and pressure in an ordinary non-lift injector, where d = diameter of throat

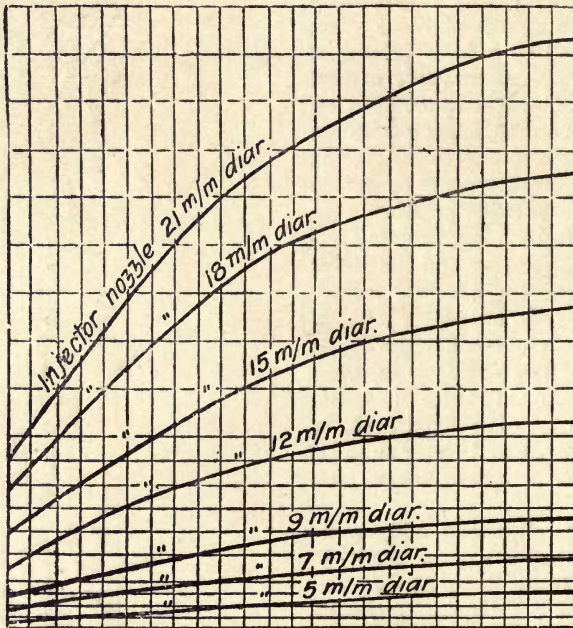

Fig. 125.—Diagram showing the Working of Boiler-feed Injectors.

in millimetres, V = volume of water delivered per hour, P = pressure of steam in pounds per square inch :—

$$d = .709 \sqrt{\frac{V}{P}}$$

$$V = 1.985 d^2 \sqrt{P}$$

according to which a No. 5 mm. size injector with steam at 60 lbs. per square inch will deliver approximately 380 gallons per hour, the same injector with 180 lbs. steam pressure being capable of delivering 650 gallons per hour—*i.e.*, an injector will increase its delivery about “one-third” by “doubling” the steam pressure, and will approximately double the quantity of water delivered on increasing the steam pressure four times; this is graphically illustrated by the diagram (Fig. 125). Thus an injector, unlike a steam-driven plunger

TABLE A.

Size In-jector in m/ms	Boiler Pressure in lbs. per square inch.																	
	20	30	40	50	60	75	90	115	130	145	160	175	190	210	230	250	270	290
Delivery in Gallons per hour at above Pressures.																		
2	35	45	50	50	60	70	70	80	90	100	100	100	110	110	120	120	130	130
3	75	95	110	120	140	150	170	180	200	220	230	230	240	250	270	290	310	330
5	220	270	310	350	380	430	470	520	560	620	640	660	680	690	710	730	750	750
7	430	530	610	680	750	840	920	1,030	1,100	1,220	1,260	1,300	1,380	1,410	1,440	1,470	1,500	1,500
9	720	800	1,010	1,130	1,240	1,420	1,520	1,700	1,820	2,020	2,100	2,160	2,280	2,310	2,300	2,350	2,370	2,370
12	1,280	1,560	1,830	2,060	2,210	2,400	2,700	3,050	3,250	3,400	3,600	3,700	3,900	4,050	4,200	4,250	4,300	4,300
15	2,000	2,400	2,800	3,100	3,400	3,800	4,000	4,700	5,000	5,300	5,600	5,800	6,100	6,300	6,400	6,500	6,600	6,700
18	2,900	3,500	4,100	4,500	5,000	5,800	6,100	7,000	7,300	7,600	8,100	8,300	8,600	9,100	9,200	9,300	9,400	9,500
21	3,600	4,400	5,000	6,000	6,200	7,200	7,700	8,500	9,200	9,600	10,000	10,500	10,700	11,400	11,700	11,900	12,200	12,500

Above quantities are based on feed water flowing to injector at 60° F., and percentage allowance should be added to delivery required on account of hot feed water in the following proportions.

TABLE B.

Temperature of Feed Water.	Delivery in Gallons per hour at above Pressures.																	
	20	30	40	50	60	75	90	115	130	145	160	175	190	210	230	250	270	290
75°	2½	2½	2½	3	3	3	3	3	4	4	4	5	5	6	6	7	8	10
90°	5	5	5	6	6	6	7	7	8	8	8	9	10	12	20
110°	8	8	9	9	10	12	13	14	15	18	24
130°	14	15	18	20	23	26	29
150°	29	33
TEMPERATURES AT WHICH INJECTORS CEASE TO WORK RELIABLY WHEN NON-LIFTING.																		
Feed Water.	150	150	148	145	142	139	135	129	124	118	112	106	100	96	90	80	75	70
Deg. F.	150	150	148	145	142	139	135	129	124	118	112	106	100	96	90	80	75	70

TABLE C.—PERCENTAGE OF ALLOWANCE TO BE ADDED ON ACCOUNT OF HIGH LIFT.

Lift in feet,	-	2	4	6	8	10	11	12	13	14	15	16	17	18	19	20	21	22
Per cent. to be added, .	-	-	2	4	6	8	9	11	15	18	22	27	33	43	54	66	—	—

The deliveries given in Table A include the steam condensed in the injector, which is equivalent to approximately 6 per cent. in weight of the feed water.

pump, increases its delivery as the pressure increases, and the same apparatus is adapted for practically any pressure—*e.g.*, the same injector may be used to deliver against 5 lbs. boiler pressure as for 200 lbs. pressure. In the tables of sizes appended, Table A gives nine sizes ranging from 2 mm. to 21 mm., with the quantities of feed water delivered with steam pressures varying from 20 to 290 lbs. per square inch; Table B shows the influence of temperature of feed water on the quantities delivered up to 150° F., and the temperatures at which injectors will cease to work reliably at different steam pressures; Table C gives the percentage of allowance to be added for various lifts, Tables B and C showing the remarkable influence of temperature and lift of the feed water on the capacity of an injector, and very forcibly illustrate without the need of further emphasis the importance of keeping the feed water and suction pipe as cool as possible in order to obtain the best results. In practice, a very trifling air leakage in the suction pipe will cause the injector to be erratic, also a very slight leakage past the back-pressure valve will cause the suction pipe and injector to become heated, and result in difficult starting. Other causes tending to an almost exaggerated influence on the working, especially from the point of view of an engineer-in-charge accustomed to the working of plunger feed pumps, are condensation or foam in the steam pipe and particles of suspended matter in the feed water; consequently it is to a high degree essential for the steam supply to be taken by an independent pipe from a point as high as possible in the boiler, and for the suction pipe to be provided with an effective strainer, the same being from time to time as required cleared by reversing the action of the injector—*i.e.*, by closing the delivery and overflow valves and turning on steam, thus blowing down the suction pipe. Another cause for trouble is deposition of hard scale on the cones, a deposit of 1 mm. in thickness reducing the capacity of a No. 7 injector, for instance, to practically a No. 5—*i.e.*, diminishes its output to within 60 per cent. of its original capacity. In cleaning the jet passages care should be taken to avoid enlarging the bore of the cones, as a trifling abrasion would, if often repeated, have the effect of materially impairing the action of the jet; for this reason it is recommended to soften the scale by soaking the cones in a 10 per cent. solution of muriatic acid; however, the makers usually provide every facility for renewals with the minimum of trouble and expense.

The injector as used for its most important application—*viz.*, as a locomotive feed pump—is principally made in sizes ranging from 7 to 12 mm., and is constructed for the most part to obtain automatic action. On a locomotive, a constant feed not being necessary or even desirable, the disadvantage of the injector in having to be worked up to within from 55 to 85 per cent. of its full capacity is no drawback, and this, taken in conjunction with its other good points—*viz.*, simplicity, lightness, and facility for being mounted in convenient position (even in duplicate)—places it on a plane unapproachable by any other form of pump. For the same reason, an injector can be usefully applied to a

stationary boiler when worked intermittently, and in many cases is valuable as a stand-by; in such applications automatic working is not necessary, nor is capacity for lifting, consequently an injector when so applied can be cut down to its simplest form.

The following representative examples of live-steam injectors will afford some insight into the peculiarities of construction adopted by different makers to meet the many and various purposes of their application. Referring to the sectional illustrations, Fig. 126 shows a single movement automatic-action Brooke injector, and Fig. 127 a similar instrument, known as the White injector, these two examples being so similar in construction, the reference letters on Fig. 127 will apply to both. The movement of the handle R attached to the valve spindle S controls the admission of steam to the nozzle B, which, by the same movement, is itself caused to

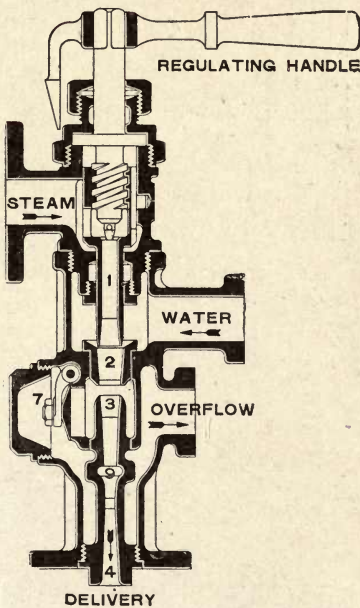

Fig. 126.—Brooke One-movement Injector, with Sliding Steam Nozzle.

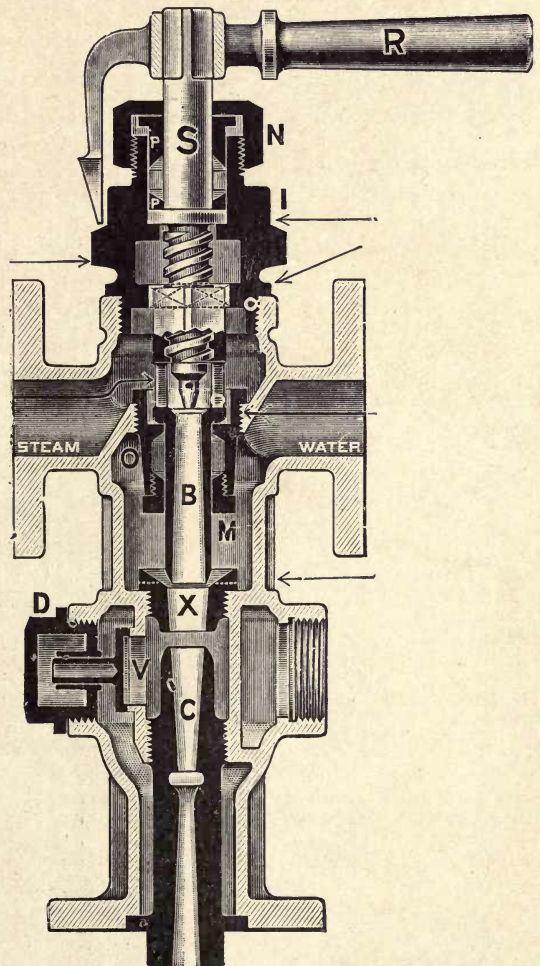

Fig. 127.—White One-movement Injector (Vertical Locomotive Type).

regulate the admission of water to the combining or suction cone X, the necessary adjustment being determined by the index pointer and dial arranged on the stuffing-box I according to the steam pressure; at O there is a second stuffing-box to prevent leakage of steam down outside the nozzle B. The combining cone is in two parts, X and C, the gap or space between these two

sections and that above the delivery cone being in communication with the relief chamber V, whence water is free to overflow momentarily at starting.

Other forms of automatic-action single-movement injectors are illustrated by Figs. 128 and 129, one being a modified form of Brooke injector with a fixed steam nozzle, and the other a Buffalo single-tube injector. The construction of both of these follows closely on the lines of the injectors already described, only differing in having a fixed steam nozzle C controlled by the pin valve A

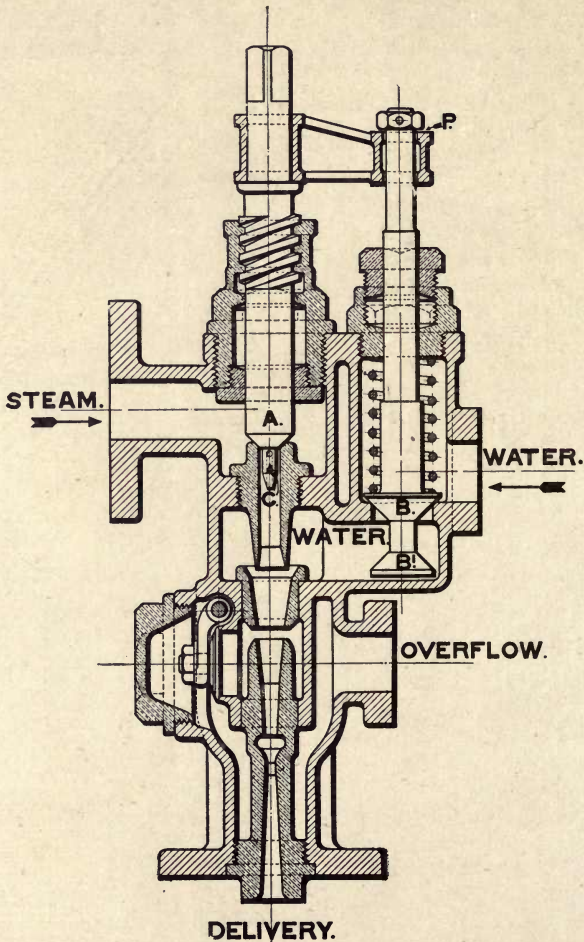

Fig. 128.—Single Movement Brooke Injector, with Fixed Steam Nozzle and Synchronous Action Regulating Valves.

and a separate water valve B connected to the screwed spindle of A by the crosshead P, by which means the two are opened and closed simultaneously. In the Buffalo injector (Fig. 129), which, by-the-way, is intended to be used horizontally, there is a double-relief chamber separated by the outwardly opening valve 17, and in this respect resembles the Powell and Penberthy injectors, which are both fitted with relief valves at the bottom of the first section of the

suction cone, the second section of smaller diameter in the Powell injector being cut across in three places to give further relief at starting, the three short gaps

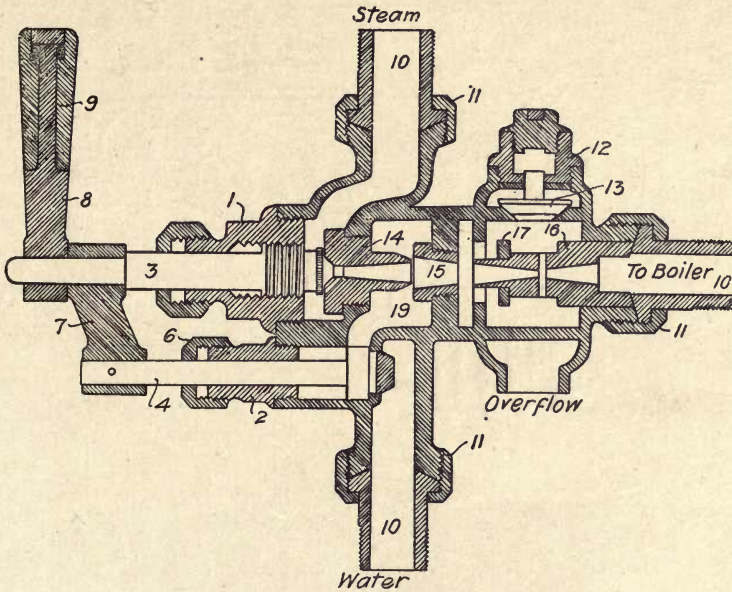

Fig. 129.—Buffalo One-movement Injector.

thus formed, as well as the valve opening into one relief chamber controlled by an overflow valve carried by a hinge, as shown in Figs. 126 and 128. A still further relief at starting is obtained in a form of split-cone injector, to be referred to later in connection with exhaust-steam injectors, a modification embodying this principle being also adopted in the Schaffer and Budenberg injector, shown by Fig. 130. In this injector, which is of the restarting automatic type, an unusually large relief chamber C is provided to accommodate the split combining cone E, which is made in halves, the section next the relief valve communicating with the overflow at L being supported on a hinge, and separates slightly at starting, thus resulting in two longitudinal gaps between the suction cone and the delivery cone, in addition to the transverse gap shown; the use of the split cone is more effective in an exhaust injector, for which purpose it was first devised by Metcalfe. In the example shown steam enters at A, and is regulated by the plug F, by which means the area of the steam nozzle is controlled to suit the pressure. In this injector, which is adapted

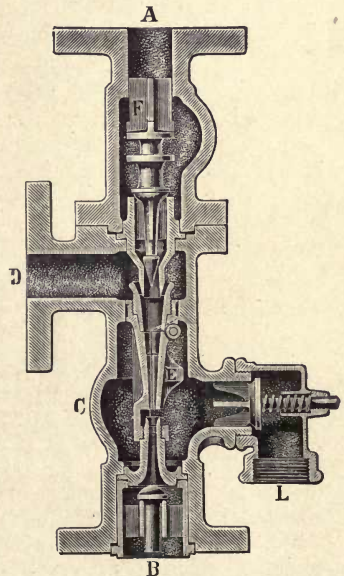

Fig. 130.—Schaffer & Budenberg Injector, with Split Combining Cone.

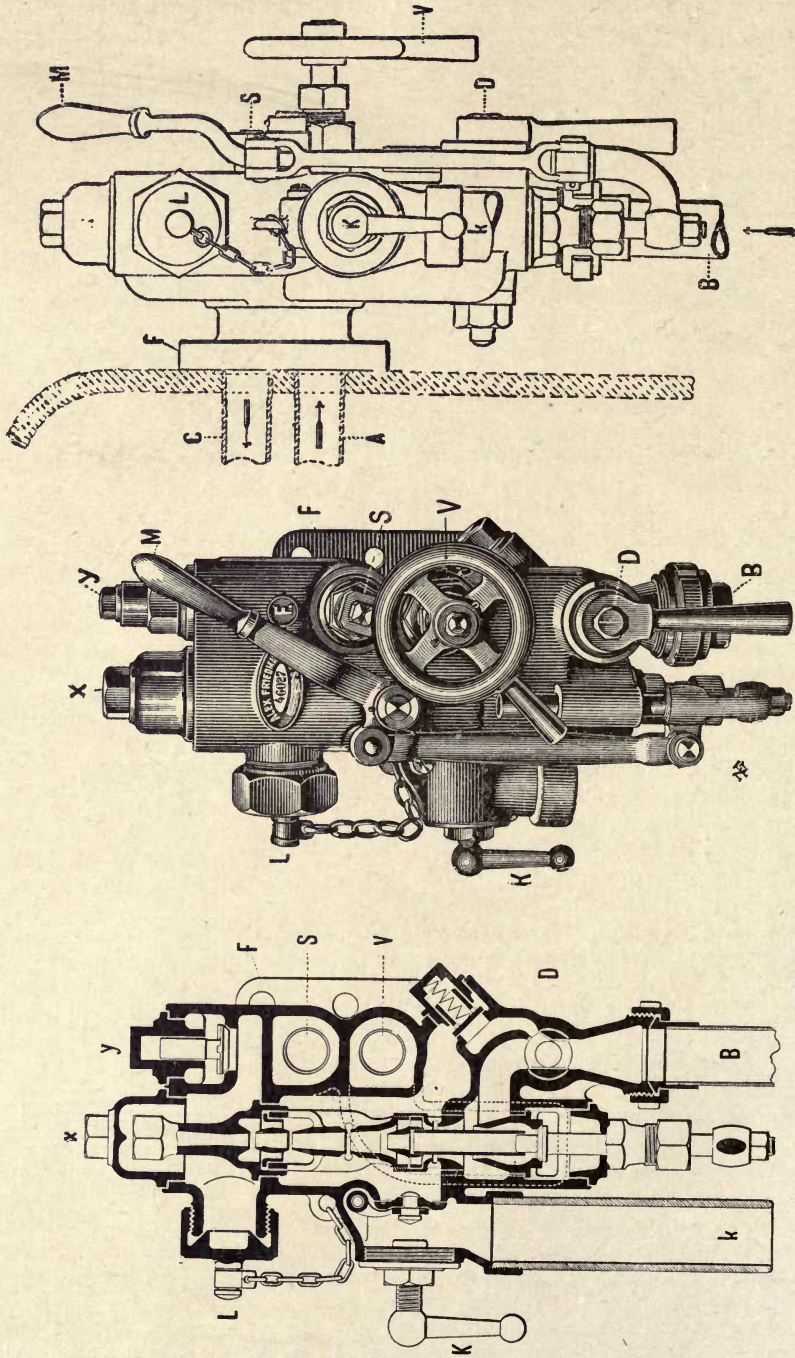

Fig. 131.—Friedmann Re-starting Boiler-fed Injector (Locomotive Type).

for taking its water supply either at or above the level of the intake D, no provision is made for the synchronous control of the water and steam together, as in the injectors shown at Figs. 126 to 129.

In the next example, illustrated by Fig. 131, a double effect is obtained by separating the steam so as to flow by a central jet and an annular jet, the water supply being induced in the form of an annular stream, which is further on changed to a central jet in a combining cone divided into three sections, the central steam jet being utilised to reinforce the flow in the combining cone. Referring to the three views of this injector, which is known as the Friedmann, A is the steam inlet, B the water suction inlet, C the delivery to the boiler, (k) overflow, K cap at back of relief valve, D water regulator, V steam valve, S delivery or back-pressure valve, M starting lever. In action the movement of M opens the double valve controlling the admission of steam to the central nozzle, and to the short annular nozzle surrounding it and projecting into the water chamber communicating with B; water from here is induced in the form of an annular stream into the suction nozzle carried by the partition separating the suction chamber from the relief or overflow chamber. The water jet here crosses the short gap separating the suction nozzle from the entrance to the first of the combining series of cone sections, into which the central steam nozzle also projects, so as to supplement the effect of the first or annular steam jet. In this manner a somewhat similar effect is obtained as in a double-tube injector connected up in series. By the removal of the cap X all the sections forming the combining and delivery cones can be taken out, and by the cap (y) the delivery or back-pressure valve can be examined; the union connection L is for the purpose of connecting up a fire hose. The function of the small valve above the water cock D is to supplement the water jet entering above the annular steam nozzle by a secondary supply, which is induced by the secondary steam jet; the construction of the Friedmann injector is thus seen to combine considerable merit with novelty, and may be answerable for its very extensive use on the Continent and elsewhere.

As will be seen from an examination of the results arising from temperature and lift, as given in Tables B and C, the capacity of an injector is very considerably reduced by either cause; moreover, an injector constructed for lifting is not so effective as a forcer, and in any case is limited in its capacity for dealing with hot water. For this reason injectors have been devised which combine the qualities of a lifter and forcer, as far as can be obtained by using two separate instruments, as in the case of the Albion injector, one of which consists of a simple form of jet pump, which is immersed in the water tank and connected to lift water to an ordinary non-lift injector, which is thus able to draw its supply from a lower level and at a higher temperature than would be possible with one instrument.

Referring to the illustration (Fig. 132), it will be seen that the lifter portion of the instrument L is immersed in the water tank, to which the forcer injector is connected by a steam pipe P, insulated from the water by the pipe N; a delivery pipe W connects the lifter (which is preferably placed so that the water can flow to it from a small head) to the forcer at a point above the throat in the ordinary way. The amount of feed is regulated by the sliding nozzle Z, a non-return valve V to atmosphere used for starting, and a regulator R, provided for controlling the steam supply to both lifter and forcer independently.

In the sectional illustration (Fig. 133) the advantages of two separate injectors connected up in series are combined in one double-tube instrument. This injector, known as the Buffalo automatic-action one-movement combined

lifter and forcer double-tube injector, is usually mounted horizontally, and consists of a short-coned lifting jet pump, arranged to supply a forcer pump having a long combining and delivery cone, the action of the two, together with the relief or starting valve, being controlled by one lever. In action, when the operating lever is pressed towards the instrument, steam is shut off from the two nozzles 22 and 24, and the relief valve 18 is opened; upon slightly withdrawing the lever, the valve 2 is raised from its seat, thus allowing steam entering by the upper union branch to flow through the passages leading to the nozzle 22

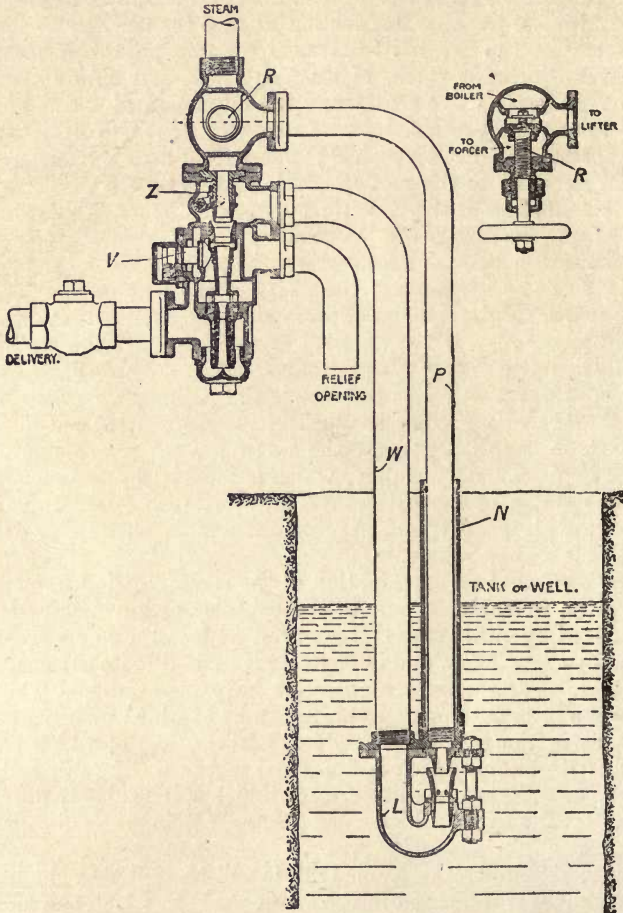

Fig. 132.—Albion Combined Lifter and Forcer Injector.

and water-lifter cones 23, thus drawing water up from the lower branch and forcing it into the cone 25, and thence out past the relief valve 18 to the overflow branch 16. Now, on withdrawing the lever still further, the end of the tube 2 projecting into the steam nozzle 24 will be moved out so as to permit steam to enter the forcer nozzle and cones 25, and result in reinforcing the jet of water supplied from 23 to such an extent as to close the valve 18 (the cam 19 being placed into position for permitting this by the action of the operating lever

and side rods 8), and cause the water to enter the boiler. Obviously water may be pumped at a higher temperature than by a single-tube injector, as, instead of the mouth of the forcer tube being open to the atmosphere, it, on the contrary, is in this case surrounded by the feed supply under pressure, thus permitting water to be forced into the boiler at a temperature above the boiling point, which is a consideration of greater importance than the capacity for a higher lift.

Another example, in which a double tube is used, is that of the Korting one-movement combined lifter and forcer injector, illustrated by Fig. 134, in which a reinforced action is obtained that only differs from the method just described in point of detail. In this injector steam supplied at H first enters the lifter and forcer cones F and F' by the steam nozzles V and V', the endways movement of which control the water as well as the steam supplies. Water is

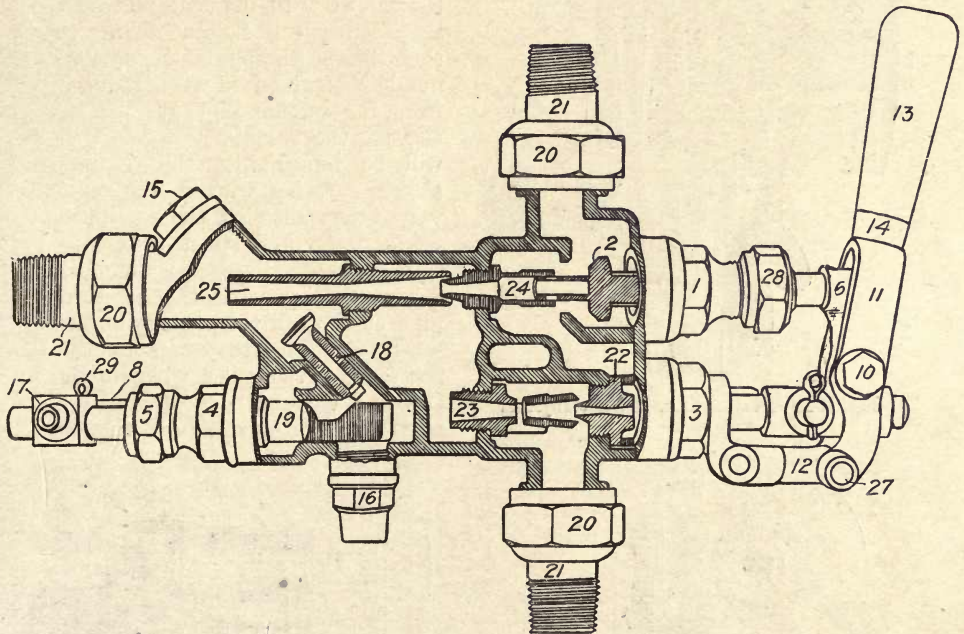

Fig. 133 —Buffalo Combined Lifter and Forcer, Double-tube Single-movement Boiler-feed Injector.

drawn into the instrument at I by the lifter cones F, and is at starting blown through the plug valve E from M and M' to the overflow pipe, the movement of the operating lever simultaneously lowering the nozzles V and V', while closing the relief plug E, when water will be forced from the bottom of F to the mouth of F', and in its passage through this second tube be reinforced by the steam jet from V', and delivered past the back-pressure valve at G and outlet K to the boiler. It will be noted that in both of these injectors of the double-tube type the combining cone in the lifter tube is short compared with that of the forcer tube, the purpose being in each case to obtain a higher suction and to feed water at a higher temperature than is possible with a single-tube injector.

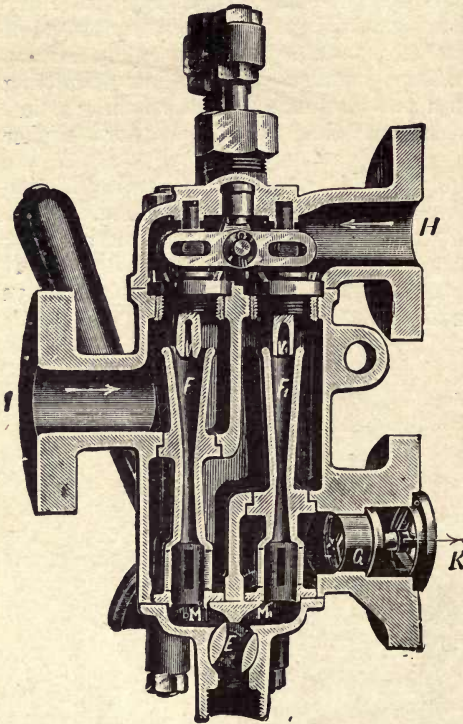

Fig. 134.—Körting Double Tube Injector

Before passing on to injectors constructed for being worked by exhaust steam, it may be interesting to describe a simple form of live steam injector, for use in connection with rail motor-coaches, traction engines, motor-wagons, etc. Referring to the sectional illustrations (Fig. 135) of this useful form of boiler feeder, we find the construction very compact, and not much exceeding in size the flange N. In action steam enters at S past the valve SV to the vena-contracta shaped nozzle SN, the steam jet then flows through the suction nozzle LN with feed water induced from the suction pipe at W; at starting the combining nozzle CN will be forced into the position shown, carrying with it the relief valve, thus allowing the combined jet of water and steam to escape from LN to the relief chamber communicating with the overflow pipe at F until the velocity of the jet is sufficient to overcome the resistance of the boiler, when nozzle CN and valve will be drawn forward and close against LN, the jet

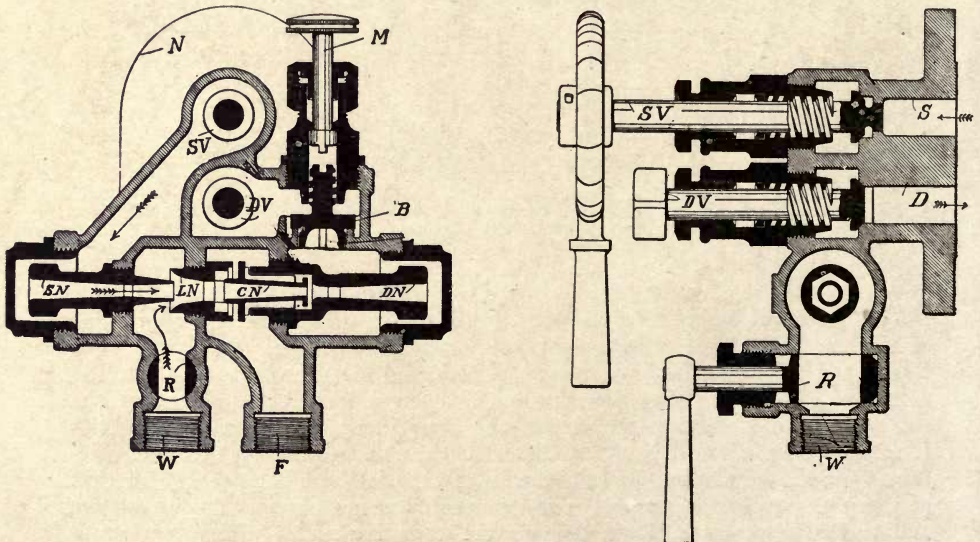

Fig. 135.—White's Injector for Traction Engines.

continuing by the delivery cone D N, past the back-pressure valve B, stop valve D V, and delivery inlet D to the boiler. The plug R is used to regulate the supply of water, and S V the steam, the two regulators being adjusted separately; the press button M is for the purpose of closing B should it stick up and allow steam to flow back after closing S V; the end of the press plunger M is also formed to engage with B for the purpose of reseating the valve in a convenient manner.

An injector constructed with a combining cone such as illustrated by L N and C N in Fig. 135 was first used by Henry Gresham, as far back as 1885, when several injectors of this make, forming part of the generating plant at the Inventions Exhibition, London, were constructed with a combining cone made in halves, the inlet end (*t*), *vide* Fig. 136, being fixed and the delivery end (*d*) being free to slide endways, a valve being also provided forming part of the sliding portion, as shown in Fig. 135, the action of which restarting device may be described as follows:—On the steam valve being opened steam rushes down the cone S N and through L N, and out at the point where this cone is divided, thus creating a vacuum in the water chamber; the water then rushes up from the supply pipe at W surrounding and condensing the steam, which in the form of partially-condensed steam and water leaps across the opening between the larger and smaller ends of the water cone—*i.e.*, across the gap between L N and C N, thus creating a vacuum in the overflow chamber leading to F, when the pressure of the atmosphere at once forces the movable half C N up to the fixed half L N, and in so doing produces a continuous water and combining cone as in an ordinary injector. The combined jet of steam and water then passes out momentarily to the relief chamber communicating with F, until the velocity is sufficiently high for it to enter the delivery cone D N, and be forced through the back-pressure valve B into the boiler through D; the automatic action of this type of injector is thus seen to consist in the opening and closing of the space between the two halves of the combining cone, this space being always open, except when steam and water are both present, and it follows that any interference with the feed will result in steam and water rushing out at the overflow until a perfect water jet is again formed, when the injector immediately starts to work without attention.

The illustration (Fig. 137) shows a modified form of White injector with movable combining cone action, arranged for being mounted horizontally, in which, as in Fig. 135, the restarting action is obtained automatically by the smaller end of the combining cone C being made to slide endways, so as to act as a relief valve at starting, as above described, this modification calling for no further explanation than that afforded by the illustration, in which S is the stem of the steam valve passing through the gland N to the regulator handle R. Steam enters at A, and water at A¹ to the chamber B, where it enters the

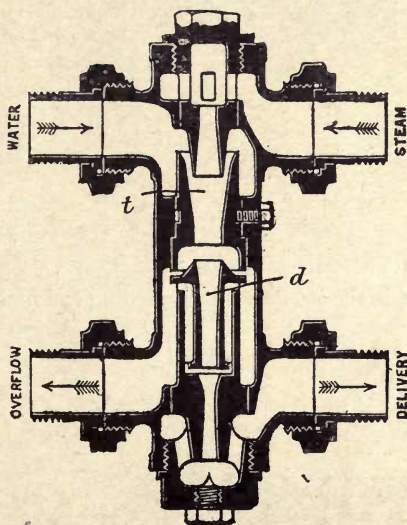

Fig. 136.—Gresham Injector (Re-starting).

combining cone, consisting of the fixed half X and the movable half C, through the delivery cone and passage K to the boiler.

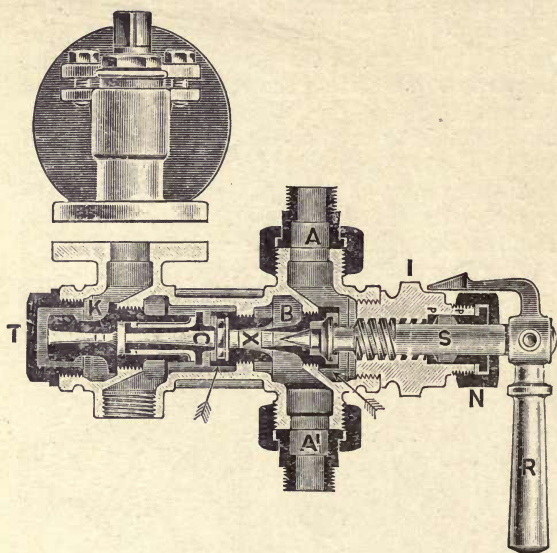

Fig. 137.—White's Re-starting Injector.

fixed and open to O through M, to which the gap D¹ also communicates, across this the jet flows when feeding the boiler through cone L and delivery pipe D².

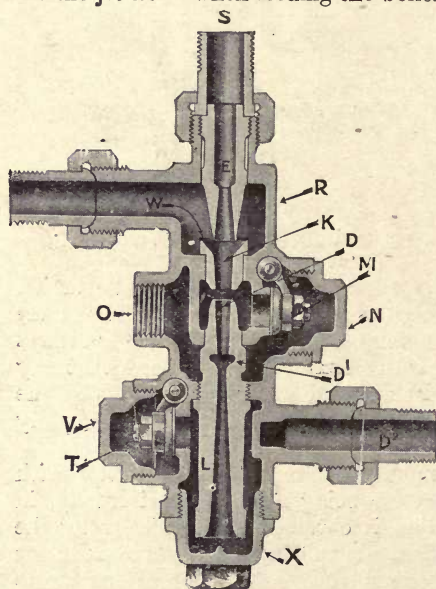

Fig. 138.—Section of Brooke Simplex Injector for use with ordinary Steam and Water Regulating Valves.

Injectors, when fitted with steam and water regulating valves, are known as combination injectors, to distinguish them from the simplex variety, an example of which is shown by the sectional view (Fig. 133), this instrument being complete with relief valve M and back-pressure valve T, but without either steam or water regulators, the necessary regulation being provided by the use of ordinary stop valves. In the illustration, steam enters at S, and rushes through the fixed nozzle E, and water by inlet W to the fixed nozzle K, the gap between K and D

Probably the greatest advance in the general efficiency of boiler-feed injectors (as applied to locomotives in particular) is to be found in Metcalfe's invention of the flap nozzle, and other improvements in connection with compound and exhaust steam injectors. As a result of developments on these lines, the compound locomotive injector, illustrated by the sectional arrangements (Figs. 139 and 139a), has been evolved, in which an important gain in economy in steam is possible, as compared with that obtaining in ordinary practice, this saving being effected by raising the temperature of the feed water from the customary 160° and 180° to 280° or even higher, such advance representing an increase in temperature of some 120° F. or so, and is obtained simply by the condensation of a portion of the exhaust, and results in an economy in practice equivalent to a return of approximately 100

gallons of water per hour to the boiler of an ordinary express engine with a consequent saving of from 8 to 10 per cent. in coal consumption.

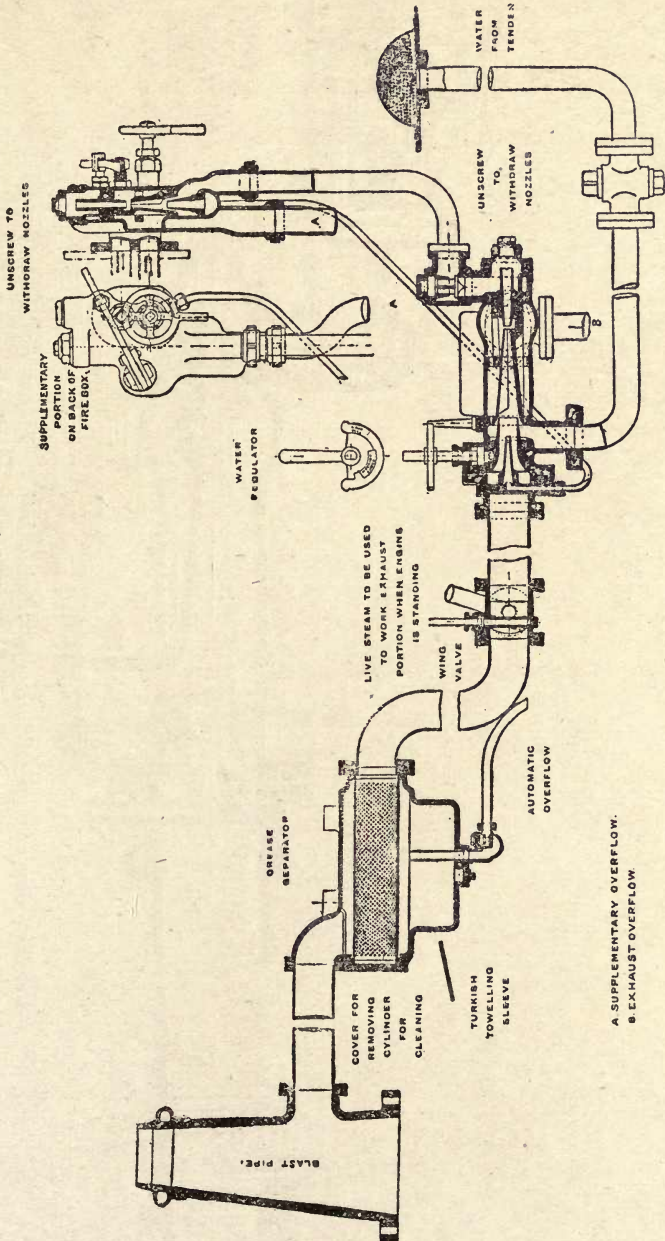

Fig. 139.—Metcalfe's Compound Injector for Locomotives, shown with the Exhaust Steam Portion arranged below the Level of the Water in Engine Tender.

Referring to the illustrations, it will be seen that no throttle is needed in the blast pipe; on the contrary, the effect of the exhaust injector rather tends towards

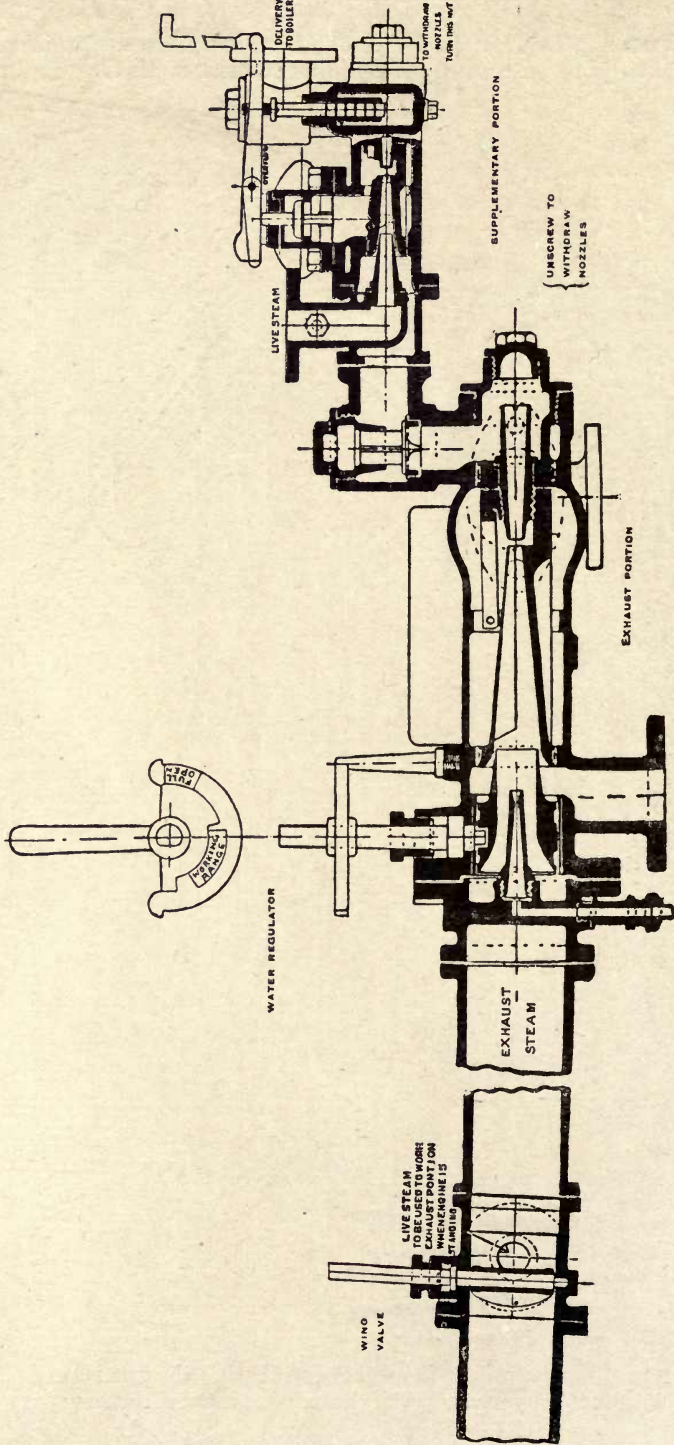

Fig. 139a.—Metcalf's Compound Injector, as constructed for both the Exhaust- and Live-steam Portions to be located below the Water Supply Level.

lowering the exhaust pressure on the principle of the ejector condenser. In practice it is advisable to strain the exhaust through a grease separator, as shown in Fig. 139, in order to avoid deposit on the injector cones, the exhaust then flowing direct to the steam nozzle of the exhaust injector, which is placed below the level of the water in the engine tender. The feed water is thus raised from 60° to 185°, or so, and delivered to the live-steam or supplementary injector which can be located either as shown by Fig. 139, which represents the exhaust injector arranged below the level of the tender and the live-steam injector mounted in the usual situation; or, as in Fig. 139*a*, where both portions are at the low level. The construction of the two portions of this compound injector closely follows the lines of the live-steam injector in that the usual series of three cones are used, and, moreover, resembles in some degree—viz., as regards the hinged-flap combining nozzle—the injector shown at Fig. 130. However, in confining our attention more particularly to the exhaust portion, we find that the steam nozzle is abnormally large in the bore, an important feature being the use of the hinged-flap opening upwards on the combining cone, which is made in halves with the underside fixed and the overside hinged as shown; this, as stated in starting, opens slightly, and thus automatically increases the area of the cone, and at the same time opens communication to the overflow outlet as soon as the injection has acquired sufficient momentum to overcome the head resistance, when the suction effect produced immediately closes this flap. To assist the action of the exhaust portion of the injector, a small subsidiary inducer nozzle is placed in the exhaust nozzle, and supplied with live steam, the necessary regulation of the water jet being obtained by moving the exhaust nozzle endways by the eccentric movement shown, by which means the driver is enabled to easily control the rate of feed.

The exhaust portion of the injector is connected up to the live steam or supplementary portion by a pipe provided with a non-return valve or direct, as shown in Fig. 139*a*; in this instance the water is forced past the non-return valve direct to the flap-nozzle combining cone of the live-steam injector portion, in the mouth of which a fixed live-steam nozzle projects some distance, this portion being provided with a delivery cone in the usual way. There is, however, a third consideration, as will be evident, in order that automatic working of the injector may be ensured—viz., means must be provided for loading the supplementary overflow relief valve to a pressure somewhat in excess of the feed from the exhaust portion—in obtaining this result a construction is followed as shown in Fig. 139*a*, in which the necessary pressure is provided by the use of a small balancing plunger acted on by steam pressure direct from the boiler; in this manner the continuity of the water flow from the suction to the delivery end of the injector can only be momentarily broken by the jolting of the locomotive or other cause.

In another form of compound-combined exhaust and live-steam injector, known as the Brooke, the necessary construction for obtaining compound working is also included, such as the combination of an exhaust portion with a live-steam portion; in this injector, however (*vide* Fig. 140), automatic action is not obtained, and there is no loaded relief valve to the live-steam portion, the overflow being controlled by a plug valve. The advantage gained by supplementing an injector by an exhaust portion, thus enabling heat to be abstracted from the exhaust steam, not only results in a fuel economy of considerable importance, owing to the high temperature of the feed, but also makes it possible to precipitate much of the impurities held in suspension before injecting the water into the boiler.

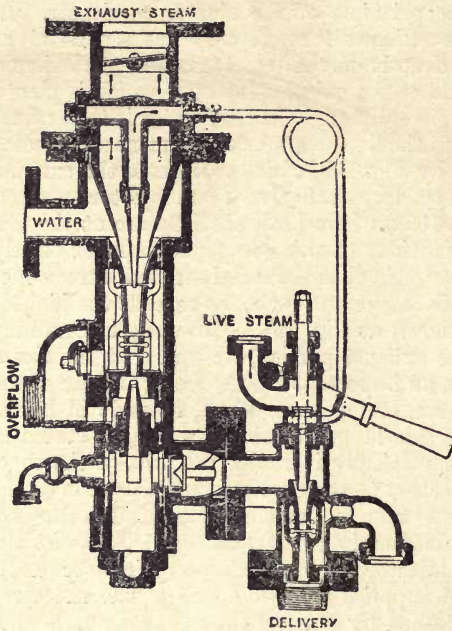

Fig. 140.—Section showing Arrangement of Holden and Brooke's Compound Non-lifting Exhaust Injector.

Exhaust steam may be used in a suitably - constructed injector, without either a supplementary live-steam nozzle or in combination with a live-steam injector for boiler pressures not exceeding 70 lbs. per square inch, and up to 150 lbs. with the addition of a live-steam nozzle to the exhaust nozzle. An exhaust injector in its simplest form is shown by Fig. 141; in this example the exhaust-steam nozzle is fixed, the area of the water jet being regulated by adjusting the casting comprising the combining and delivery cones endways by means of a screwed attachment at the bottom, a flap-nozzle combining or suction cone being also used in this injector, in the working of which the extent of the opening permitted to the flap is plainly discernible.

In the earliest form of boiler feed injector capable of being operated with steam at exhaust

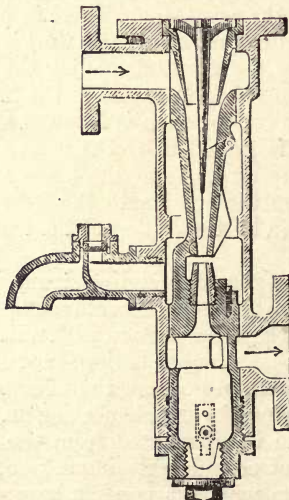

Fig. 141.—Schäffer and Budenberg Exhaust Injector.

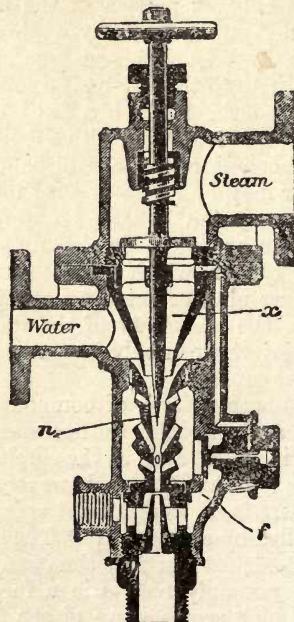

Fig. 142.—Mansfield Exhaust Steam Injector.

or atmospheric pressure—viz., the Mansfield—as shown in Fig. 142, the delivery cone (*n*) was drilled with a number of openings at 45° with the relief chamber (*f*), while the exhaust steam cone (*x*) was provided with a regulator plug, as used in the original Giffard live-steam injector.

An exhaust steam injector is capable of forcing against from 70 to 75 lbs. boiler pressure with feed water not exceeding 60° to 65° F., and supplied at a slight head. The volume of steam such an injector is capable of condensing in the performance of its work averages from 2 to 2.5 cubic feet per pound of feed-water, which it delivers at from 165° to 185° F.

Jet Pumps.

Turning now to steam-jet water lifters or jet pumps, we find these most useful instruments very convenient for a number of purposes, such as for filling the water tanks in traction engines, ejecting bilge water in steam barges, and

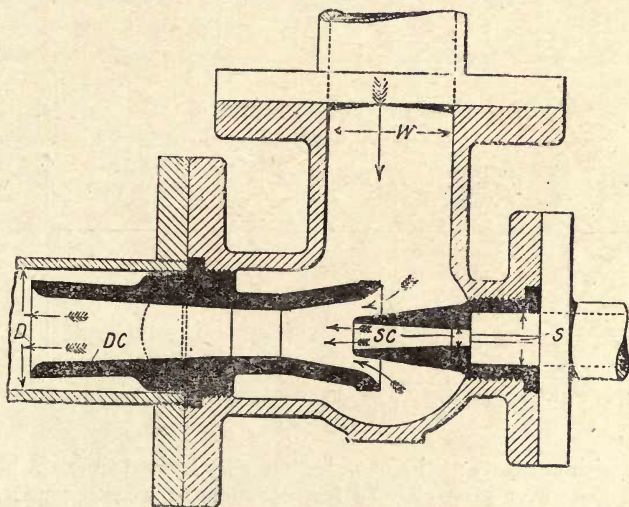

Fig. 143.—White's Jet Pump.

the like; they may also be used for excavating sand or mud from wells, and in combination with a hydraulic jet they may be usefully applied for elevating water from tunnels, and have been used in stages for emptying mine shafts. As an exhauster, they are in common use for priming centrifugal pumps, for filling creosoting tanks, elevating viscous liquids by suction effect; and as a circulator are used in kiers, gas holders, and for other purposes where a liquid is either required to be gently circulated or maintained at an even temperature.

A useful form of water lifter is the White jet pump, shown at Fig. 143, in which steam is supplied at *S*, and caused to issue at a high velocity from the steam nozzle *S C* into the combined suction and delivery cone *D C* communicating with the delivery pipe *D*, which is about double the diameter of *S*, and of the same size as the suction inlet *W*. The proportions and working capacities of various sizes of jet pumps under steam pressures ranging from 25 to 100 lbs., and for heads from 33 to 80 feet, are given in Tables *D* and *E*; from these dimensions it will be noted that a very small jet indeed is needed for a very

considerable output. The effect of lift is shown in Table D, also the relation of steam pressure to height of delivery, and in Table E will be noted the capacities of lifters up to 16,000 gallons per hour, thus demonstrating their suitability

TABLE D.—SHOWING WORKING OF JET PUMPS.

Steam Pressure in Lbs. Per Square Inch.	Suction Lift in Feet.			
	4	8	12	16
	Height of Delivery in Feet.			
25	20	18	16	15
50	45	43	38	35
75	65	60	58	55
100	80	75	70	65

TABLE E.—SHOWING CAPACITY OF JET PUMPS.

Height. Feet.	Delivery Per Hour. Gallons.	Bore of Nozzle. Inches.	Diameter Steam Pipe. Inches.	Diameter Water Pipe. Inches.
33	900	$\frac{1}{4}$	$\frac{3}{4}$	$1\frac{1}{2}$
50	3,000	$\frac{1}{2}$	$1\frac{1}{2}$	$2\frac{1}{2}$
66	6,000	$\frac{3}{4}$	2	$3\frac{1}{2}$
80	16,000	$1\frac{1}{2}$	$3\frac{1}{2}$	6

Above quantities are based on a steam pressure of 30 lbs. per square inch, and with no suction lift.

for dealing with large quantities of water in a very limited time. A high economy of working has never been claimed for this means for raising water, the great advantage of the jet pump in its simple form resulting from its low cost and exceeding convenience for the many purposes wherewith their use is only required temporarily or intermittenly. The ejector shown by the sectional cut (Fig. 144) represents its application as a bilge-water pump, in which connection will be noted the self-closing throttle valve at the discharge, also that the ejector although constructed for working against a low head, is of great capacity, and resembles very closely ejectors used for exhaust condensers. A word here in regard to the steam used:—The efficiency of a jet pump corresponds to the well-known formula for efflux of water, $V = 2gh$, the divergence being greatest at the higher pressures; while about 30 lbs. of water can be raised from 40 to 50 feet, on 1 lb. of steam at 25 lbs. pressure per square inch, and as much as 15 lbs. weight of water can be raised from 140 to 160 feet by the consumption of 1 lb. of steam at 100 lbs. pressure; the output only falls to 10 lbs. of water per pound of steam used at 200 lbs. pressure when working against a head of 300 feet or so; these observations are taken from a most perfect form of injector of the boiler-feed type, drawing its water supply from a lift of 2 feet and at a temperature of 65° F. Judging from these results, it must be admitted that the

jet pump when considered from the point of view of its application as a feed pump, for which purpose the heat imparted to the water is for the most part returned to the boiler, is capable of working with a very high efficiency; for instance, 1 lb. of steam at 200 lbs. per square inch, representing 1,200 B.T.U., will force 11 lbs. of water against this pressure, and raise same in temperature from 60° to 170°, thus practically accounting for all the heat value of the steam used. Again, 1 lb. of steam at 100 lbs. per square inch, and representing 1,184 B.T.U., will deliver 15 lbs. of water against 100 lbs. pressure, and at a temperature from 70° to 150° F.; and steam at 50 = 1,170 B.T.U. will deliver 20 lbs. of water for each pound of steam used, and raise same from 80° to 140° F.; but considered as a "jet-pump" apart from "heating," the injector works with a very low efficiency indeed, for whereas 11 lbs. of water in being lifted 460 feet only represents the equivalent of 6.5 B.T.U., the pound of steam at 200 lbs. pressure required for energising the injector represents 1,200 B.T.U.; and is worse with steam at 50 lbs. pressure in lifting 20 lbs. of water 116 feet, for although a pound of steam at this pressure is the equivalent of 1,170 B.T.U., the water lifted only represents 3 B.T.U.

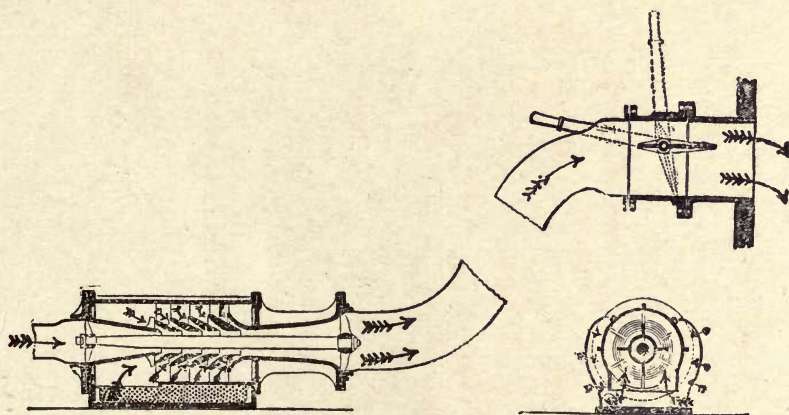

Fig. 144.—Friedmann Bilge Water Ejector.

The low efficiency of a jet-pump is perhaps better realised in comparing it with a plunger pump, which in ordinary good practice requires (working compound) three times the theoretical amount of steam to force water at equal pressures, and about five times this amount when working non-compound; whereas an injector requires from 16 to 20 times this amount. And whereas a compound pump may require from 2 to 6 lbs. of coal per P.H.P., and a non-compound pump perhaps as much as 10 lbs. per P.H.P. per hour; an injector to lift 50 feet will require at least 24 lbs. of coal per P.H.P., and to lift 200 feet not less than 18 lbs. per P.H.P. under the best possible conditions, from which it will be seen that an injector of the most approved form, when viewed from the point of view of economy only, is an extravagant appliance for raising water.

Ejectors.—A modification of the injector principle has been successfully applied as a condenser for large stationary steam engines; in this connection a water jet takes the place of the steam used in the injector proper, and in passing through a succession of nozzle cones (thus exposing as large a surface as possible

to the exhaust) the steam is not only condensed, but by the inductive action of the water jet, air, and vapour from the exhaust is drawn away with such effect as to be able to maintain a vacuum of 24 inches under ordinary conditions; the best results can be obtained with low temperatures, and with the cooling water supplied to the ejector at a head of not less than 20 feet, and in quantity equalling at least 25 lbs. of condensing water per pound of steam exhausted from the engine. A practical application of the injector principle was first made by Morton, in 1867—*i.e.*, within a few years of the introduction of the Giffard boiler-feed injector, Morton's ejector condenser being made closely on the lines first laid down by

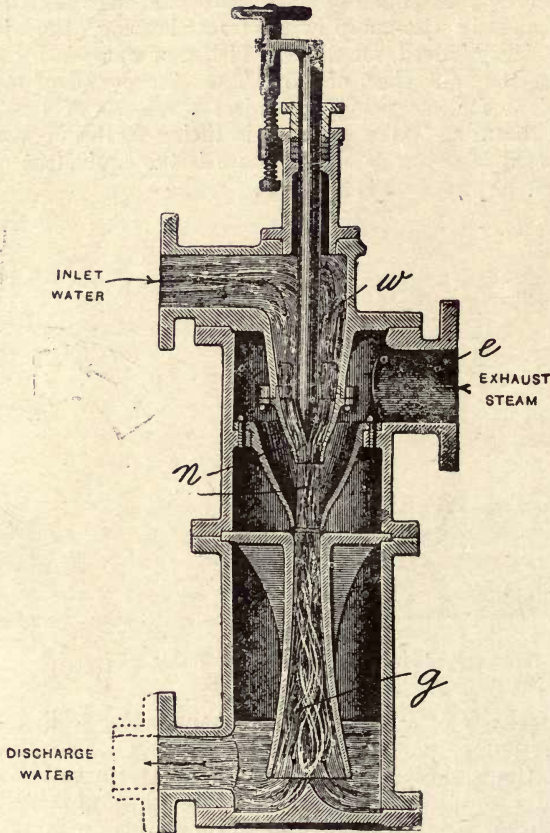

Fig. 145.—Morton's Ejector Condenser.

this inventor (*vide* Fig. 145), although in all fairness it should be mentioned that condensing on this principle was first attempted by Mazeline in 1860, and later by Barclay in 1864. Since this time ejector condensers have been considerably improved in detail by Körting, Ledward, White, and others (*vide* Figs. 146 to 148), in all of which the aim is directed towards obtaining a maximum of contact of the steam with the water; from the sectional view of the White ejector, for instance, it will be seen that the apparatus consists of an exhaust chamber E, containing a series of cone sections or nozzles N, into which a water jet supplied to the nozzle W at a head of from 15 to 20 feet is projected; the

gaps between the several cones expose considerable surface of the jet to the exhaust steam flowing to the chamber E; the jet flowing through the series of cones contained in the condensing chamber is continued through a delivery or discharge cone G, which is connected to a downtake pipe of 6 to 10 feet in length, and terminates in a hot-well, thus making a water seal. There is usually a non-return valve between the chamber E and the engine cylinder to prevent

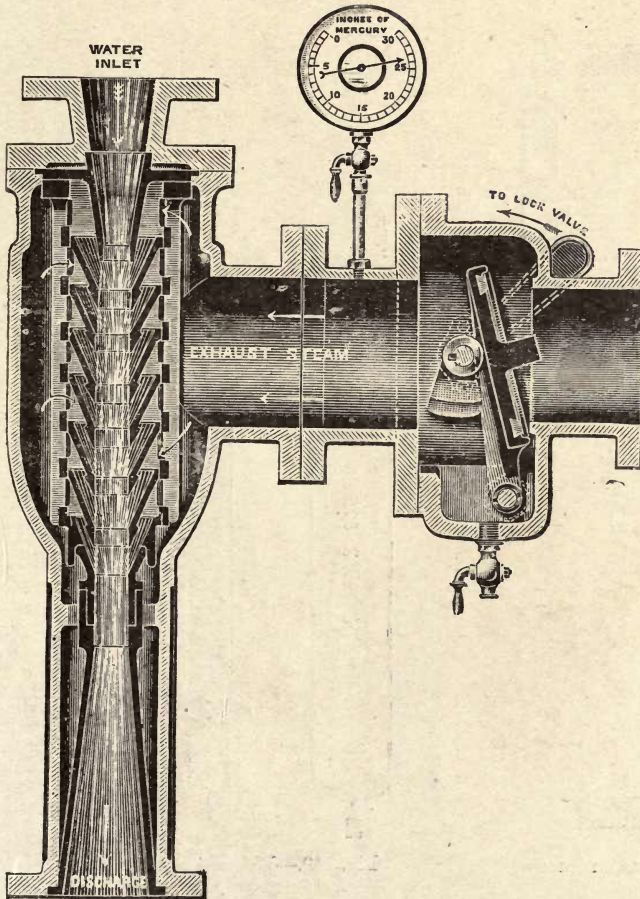

Fig. 146.—Ledward Ejector Condenser.

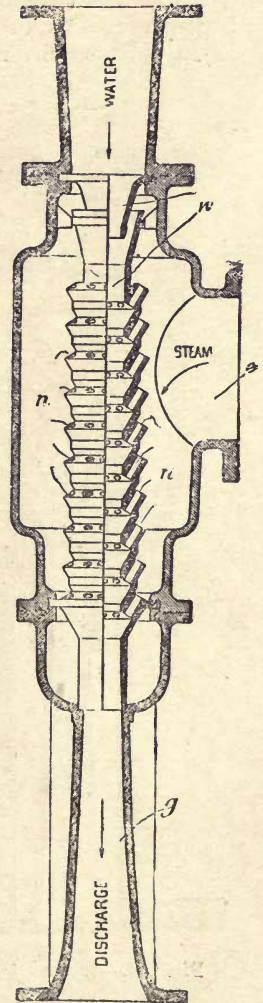

Fig. 147.—Körting Ejector Condenser.

water from the discharge well being drawn up into the cylinder should the engine be stopped without previously shutting off the water supply; this valve is necessarily of large area, and is usually swung on pivoted connections for obtaining instant closing, so as to avoid the possibility of flooding the engine cylinder.

Obviously it is important to exclude air from all connections leading to an

ejector condenser of the kind described, in order to obtain a satisfactory result; also the condensing water should not exceed 60° F., under which conditions provided that not less than 20 feet of head is given to the water supplying the ejector nozzle: the quantity of condensing water required per pound of steam and per indicated horse-power, together with the internal diameters of exhaust, water, and discharge pipes, is approximately as given in Table F, from which it will be seen that from 75 gallons for small powers to 65 gallons of water for large powers is required per indicated horse-power per hour.

In order to obviate the possibility of water being drawn into the engine

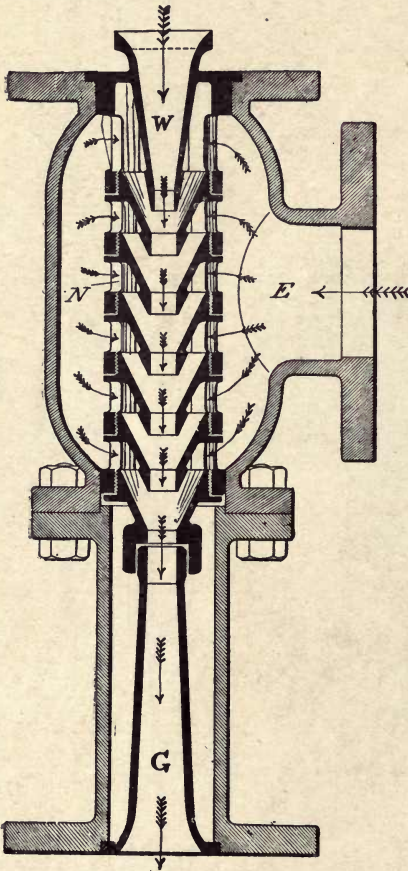

Fig. 148.—White Ejector Condenser.

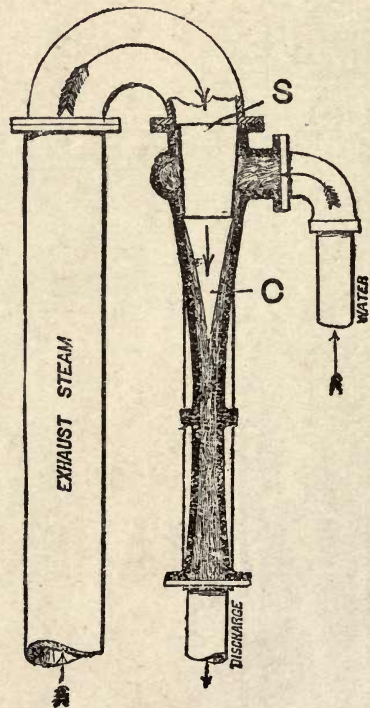

Fig. 149.—Exhaust Ejector for Barometrical Condenser.

with or without a non-return valve in the exhaust pipe, barometrical ejector condensers are sometimes used, of which an example is given by Figs. 149 and 150. In this case the downtake or discharge pipe from the ejector is continued down some 33 feet into a hot-well as before, by which means water is not only prevented from getting over into the exhaust pipe, but can be supplied at a lower head. In this ejector apparatus, sometimes known as the Bulkley ejector condenser, steam enters a cone formed by the steam nozzle S projecting into the

TABLE F.—WORKING OF EJECTOR CONDENSERS.

Steam Condensed Per Hour. In Lbs.	Water Required Per Hour. In Gallons.	Horse-power of Engine. Indicated.	Internal Diameter of Pipes.		
			Exhaust. Inches.	Water. Inches.	Discharge. Inches.
400	1,100	15	2½	2	1½
1,600	4,000	50	4	3	2½
4,000	11,000	150	7	5	4
12,000	33,000	500	12	8	7

suction or combining cone C, the annulus around the nozzle S being formed to produce a gyrotory movement to the condensing water. In the arrangement

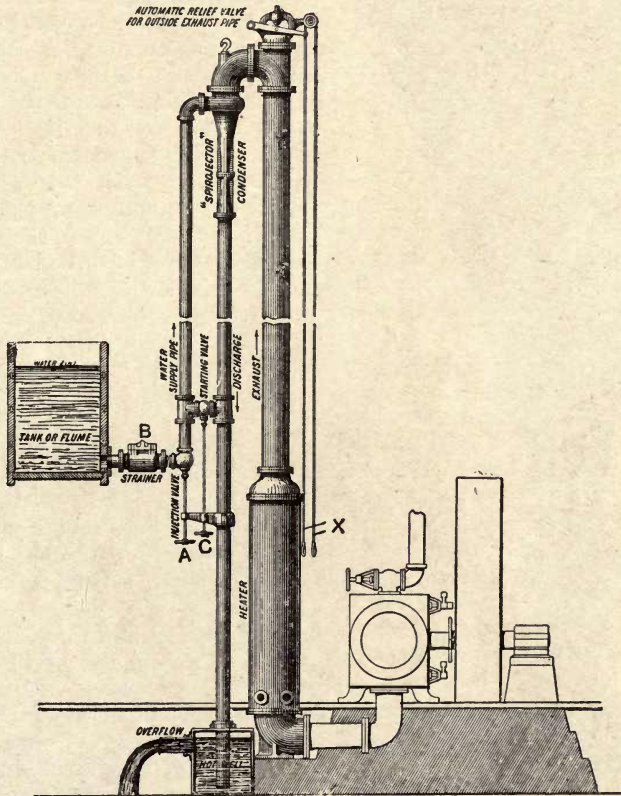

Fig. 150.—General Arrangement of Barometrical Ejector Condenser.

shown at Fig. 150 a by-pass valve C is provided to allow the condensing water to flow down the discharge pipe at a point about the level of the tank at starting, a portion of the steam being allowed to exhaust momentarily by the valve at the top of the exhaust uptake ; but as soon as a circulation has been established, the syphoning action of the lower half of the discharge pipe will balance the

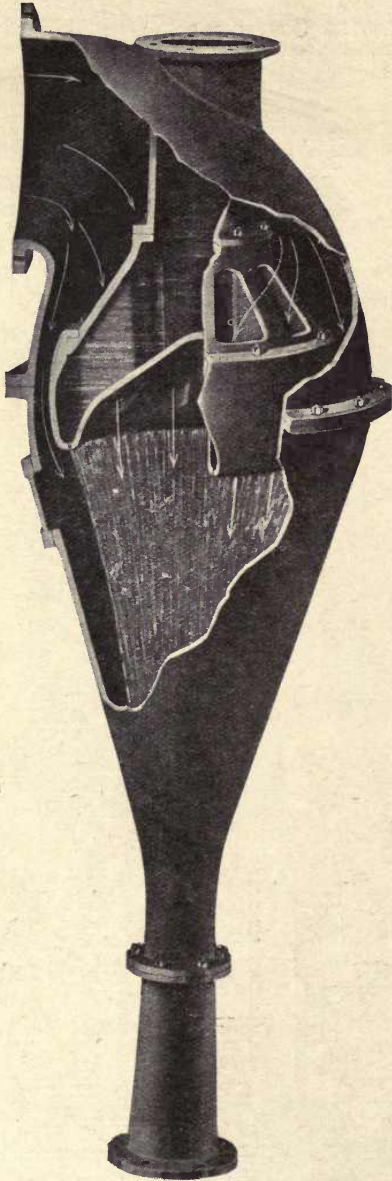

Fig. 151.—Worthington Barometrical Condenser Ejector.

column from the tank to the ejector, when the starting valve and the exhaust outlet may be closed by the hand-wheel C and rope connection X; the supply of condensing water can be adjusted by the injection valve A. In place of the condensing water being supplied from a tank as shown, a pump may be connected up to the water-supply pipe at the ground level, in which case a starting by-pass valve is not required.

For large establishments where steam is required to be exhausted from several engines of considerable power, a central apparatus of the kind illustrated by Fig. 151 can be employed with both convenience and efficiency; this exhauster, known as the Worthington conojector, consists of a condenser cone provided with an annular perforated sprayer, by which the steam from the one side and the water from the other are thoroughly combined, and after flowing through the cone, fall by gravitation down the tail pipe of the condenser. The velocity of the downflow is sufficient to produce a vacuum of ordinary degree, provided that leakage of air is prevented; but for obtaining a high vacuum and neutralising the effect of air leaks in long exhaust and discharge pipes, a dry vacuum pump of comparatively small capacity may be employed with advantage. Injection water is supplied as in an ordinary ejector barometrical condenser, the water uptake column balancing the column in the discharge pipe. The advantage of barometrical ejector condensers is mainly due to their independence of not only air pumps, but of all valves and to their capacity for dealing with large volumes of steam, such as produced in sugar refineries and other installa-

tions where boiling and evaporating *in vacuo* are carried on at a low temperature.

CHAPTER XIII.

VACUUM AND CONDENSER PUMPS.

ALL the early steam engines, such as those of the Newcomen type, depended entirely for their action on an injection of condensing water in the working cylinder direct, the power piston in these engines acting as its own air pump in expelling through a snifting valve all uncondensed vapours and air, as well as the injection water supplied by a jack-pump worked off the horse-head shown in Figs. 1 and 2 (*ante*); the use of air pumps—*i.e.*, pumps employed for exhausting injection water, air, and water of condensation—in connection with the more economical working of steam engines being coincident with Watts' introduction of the separate condenser previously explained. The importance of the condenser may be gathered from the practice followed by engineers of those days in using low pressures, with which from three-fourths to four-fifths of the total power of the engines was due to atmospheric effect alone, and even with present-day high pressures and multiple-stage expansion the effect of the condenser is to increase the economy and power of an engine from 20 to 30 per cent., the latter figure applying more particularly to the steam turbine, in the working of which high efficiency of the condensing plant is of even greater importance than with reciprocating engines.

As the purpose of this chapter is concerned for the most part only with the various types of pumps used, the construction and working of condensers proper (being a subject requiring separate consideration) will not be specially entered into. In jet condensers the volume of condensing or injection water necessarily depends on the temperature and available supply, as well as on the degree of vacuum to be obtained, the volume of injection water required for jet condensing not materially differing from the working of an ejector condenser—*viz.*, from 20 to 25 lbs. per pound of exhaust steam. The comparative proportions of an injection pump, air, and water exhaust pump, and boiler-feed pump for a single cylinder horizontal, 18 by 24 inches, engine are illustrated by Fig. 152, where D is the exhauster for the injection water, air, and condensed steam, and is known always as the "air pump," whether used in connection with a jet or surface condenser; condensing water is supplied at W to the injection pump A, which forces it to the chamber B, whence it flows (by the pipe shown) to the injection diffuser J, and is thereby sprayed directly in the path of the ingoing exhaust steam at X. The pump D is fitted with a single-acting bucket piston, foot, and head valve, each valve being either a single rubber disc, as shown, or as sometimes used consists of thin metallic discs, in which variety it is known as the Kinghorn valve; the endeavour in all cases is the same—*viz.*, to construct a valve capable of a perfectly airtight fit on its seat and with a durable action, and to be such as to oppose the least possible resistance to the flow of vapour, air, and water; valve perfection is a desideratum that applies more pertinently to the inlet than to the outlet of the pump, and probably the cause of more differentiation in the design of air pumps than any other factor, the

foot valve especially being considered an organ to be avoided by many makers at any cost, and will be referred to later in the description of a few representative examples.

In the case of surface condensers, where the circulating water has not to be pumped against atmospheric resistance, the percentage of condensing water used as compared with the volume of injection water required in a jet condenser may be considerably increased with advantage, the slightly additional power absorbed in circulating sufficient cooling water through the condenser to maintain it at a temperature within 10° or so of the intake being to a great extent compensated for by the improved vacuum obtained; and is a practice more especially justifiable

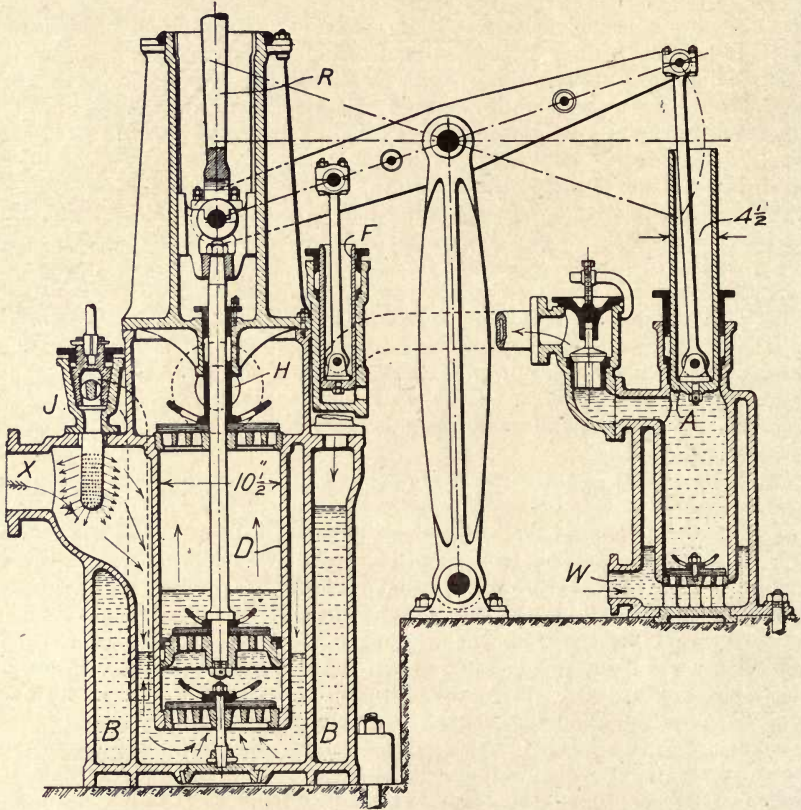

Fig. 152.—Jet Condenser Air Pump combined with Circulating and Feed Pumps.

where a plentiful supply of water is available, and where highly-efficient centrifugal pumps can be conveniently employed for this purpose. The capacity of a circulating pump of the plunger type should be approximately the same as that of the air pump—viz., equal in terms of the volumes swept by the plunger of the pump and piston of the low-pressure cylinder, and is as 1 to 20-30—but is influenced to some extent by the bias of the designer, to temperature, head, and available supply of water.

In the proportioning of air pumps there is found to be considerable disparity, not only is this the case in actual practice, but in the various formulæ expressed

for this purpose ; according to Kempe the diameter and stroke of a single-acting air pump is as follows :—

$$d = \cdot 0412 D \sqrt{S \left(\frac{890 + T}{V} \right)},$$

$$s = \cdot 0017 D^2 S \left(\frac{890 + T}{V d^2} \right).$$

where d = diameter, s = stroke of the pump, D = diameter, S = stroke of the low-pressure steam cylinder, V = volume, and T = temperature of exhaust steam. According to this formula the volume swept through by a single-acting air pump is about one-twelfth that of the low-pressure cylinder. A much simpler expression is given in Fowler's *Mechanical Engineers' Pocket Book*, as follows :—

Volume swept by air-pump plunger or piston =

$$\frac{\text{I.H.P.}}{\text{Revs. per minute}} \times C \text{ in inches ;}$$

where $C = 700$ for a single-acting jet condenser, and 300 for a single-acting surface condenser—*i.e.*, the capacity of the pump for a jet condenser should be rather more than double that of a surface condenser—the extra capacity being required for the purpose of dealing with the extra injection water, which in this case must be pumped out in addition to the condensed steam and air.

However, as it is impossible to express in one equation the correct proportions to be followed under the many and varying conditions obtaining in actual practice, a few examples of cylinder and pump capacities found in engines of quite different types and working under widely divergent conditions will not only be interesting, but useful for the designer and others.

Taking first engines of the jet condensing type, which, by-the-way, are more commonly used in the States and on the Continent than with us, we find that in a Powel horizontal compound engine, in which the low-pressure cylinder is 40 inches diameter by 41 inches stroke, the cylinder capacity is nine times greater than the two single-acting air pumps of 20 inches diameter by 19 inches stroke. Then, again, in a Trikart horizontal compound engine made by the Sctè. Alsaciennè, Belfort, we find a low-pressure cylinder 23 inches diameter by 46 inches stroke, and a double-acting air pump of 11 inches diameter by 12 inches stroke, the difference in this case being 16·5 to 1. In yet another example of a jet-condensing engine—*viz.*, a triple-expansion vertical air compressor made by Schneider of Creusot—we find a low-pressure cylinder of 78 inches diameter by 55 inches stroke, and two single-acting air pumps 33 inches diameter by 16 inches stroke, thus presenting a proportionate capacity equal to 20 to 1 ; and in a Borsig electric light triple-expansion engine, having two low-pressure cylinders 52 inches diameter by 47 inches stroke, we find two air pumps, each 43 inches diameter by 10 inches stroke, thus giving a proportion of 21 to 1, in the relative capacity of cylinders and pumps.

Turning now to air pumps used in surface-condensing engines, we find in the H.M.S. "Powerful" two low-pressure cylinders having a diameter of 76 inches each by 48 inches stroke, and two single-acting air pumps, each 27 inches diameter by 21 inches stroke, the proportion of cylinder capacity to pump capacity being in this case 36 to 1. Again, in the Dutch cruiser "Noord Brabant" the low-pressure cylinder is 74 inches diameter by 39 inches stroke, and the air pump 24 inches diameter by 24 inches stroke, thus giving a proportion of 22

to 1; and in the U.S.A. cruiser "Denver," with two low-pressure cylinders 36 inches diameter by 30 inches stroke, we find one single-acting air pump 22 inches diameter by 10 inches stroke, with a corresponding proportion of 31 to 1. In another marine example—viz., the G.W.R. steamer "Lynx"—the proportion of cylinder capacity to pump capacity is 33 to 1, and, lastly, in the compound hydraulic engines at the Millwall Docks there are two low-pressure cylinders 38 inches diameter by 40 inches stroke, and two single-acting air pumps 18 inches diameter by 20 inches stroke, with a proportionate capacity of 18 to 1. In each of these instances the air pumps are driven by direct connection with the piston-rods as in the engines used for stationary purposes, and as shown by Fig. 154 in marine practice.

The average proportion in the above examples of jet-condensing engines is

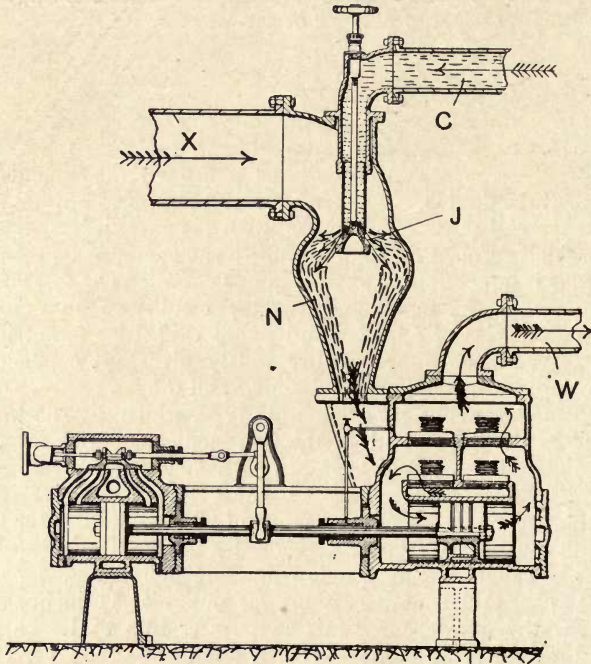

Fig. 153.—Worthington Independent Jet Condenser

thus seen to be approximately 16 to 1, and in the case of surface-condensing engines 28 to 1; while the proportion found in marine engines, when considered apart from stationary engines, is in terms of the volume swept by the low-pressure pistons to that of the air pumps as high as 38 to 1. The explanation for the high proportion found in marine engines is probably due to the available supply of circulating water being more constant and obtainable at a more even temperature than experienced in connection with the working of stationary engines.

Air pumps, whether directly driven or of the independent class, are more often vertical than horizontal, the vertical construction favouring the action and arrangement of valves in and above the piston, so as to obtain a minimum clearance so essential to the efficient working of an air pump, when employed in connection with a surface condenser, in order to enable it to effectively

exhaust for the greater proportion of each working stroke a fluid rarefied to 24-28 inches of vacuum, as indicated by the mercurial gauge. For this reason the most usual construction followed in air-pump practice has been to make its compressing end double-acting, as shown by Figs. 152 to 154, as by this means the foot valve is relieved of all pressure except that due to the tension of the clearance vapours remaining above the piston at the termination of the up-stroke. In marine practice vertical pumps of the construction shown by Fig. 154 are practically universal when arranged so as to be driven from a beam connected at one end to one of the crossheads, and indeed this type of single-acting vertical two-stage pump is very commonly used in horizontal and vertical engines used for stationary purposes, especially when arranged to work surface condensing;

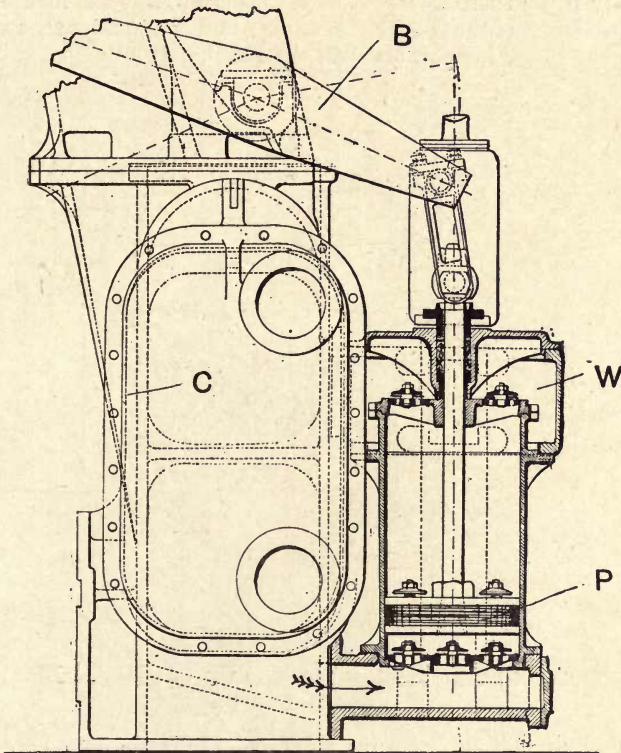

Fig. 154.—Marine Type Air Pump, with Bucket Piston and Foot Valves.

in which case the pumps are often arranged in pairs, so as to be driven from a double quadrant lever connected to the tail-rod of the low-pressure piston. Fig. 152 represents an arrangement of injection and air pumps for a horizontal engine, to which they are connected by the rod R to a quadrant lever at the low-pressure end of the engine. Fig. 155 shows another driving arrangement as used in a vertical jet-condensing engine; in this example a pair of pumps are driven from a rocking shaft S, links K, and rod D to an out-end crank on the engine. A very simple arrangement, and capable of being situated closer up to an engine of horizontal construction, is illustrated by Fig. 158, this pump being double-acting and connected in a very direct manner to the

crosshead of the engine. A still more direct manner of connecting an air pump to a horizontal engine is to place it tandem-wise to the low-pressure cylinder and drive the plunger from the tail-rod.

For many purposes independently-driven air and circulating pumps have an advantage over directly-connected pumps; especially is this the case in electric light and power stations, where the load fluctuates to such an extent—and often so suddenly—as to require additional units set into motion with the least possible delay; the further advantage resulting from the simplification of the plant generally and the foundations in particular are also of considerable importance. From the point of view of economy in driving power, independently-actuated condenser pumps have an undisputed advantage, the speed of each auxiliary being thus capable of adjustment to meet the load on the main engine independently of the speed it is running; and is a practice that avoids much of the waste of power inseparable with the running of an engine with directly-

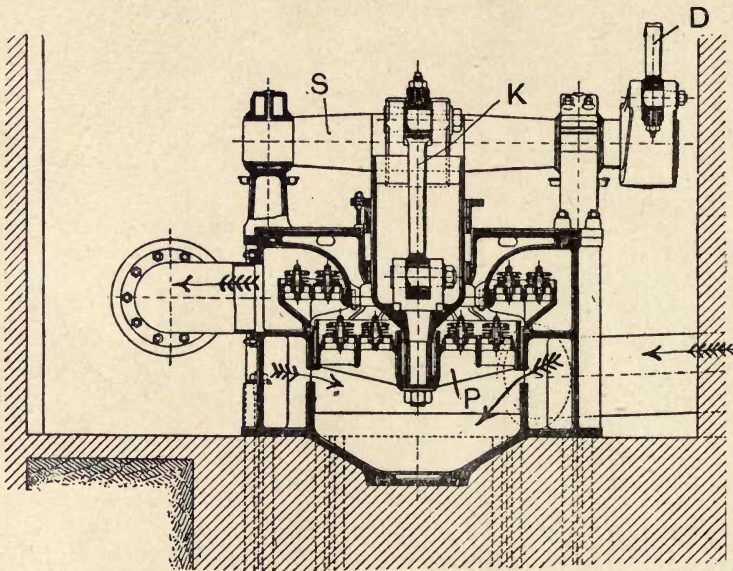

Fig. 155.—Bucket Piston Air Pump without Foot Valves, for Triple-expansion Borsig Engine and Jet Condenser.

driven air and circulating pumps at reduced loads, as in such cases, while the pumps are caused to work at their full power and speed, they are not by any means running at their most useful capacity. The advantage of independently-driven air and circulating pumps is also recognised in marine practice generally, but more especially in connection with battle-ships, cruisers, torpedo-boats, and the like, where, partly on account of the higher speed of the engines, and partly owing to greater facility being afforded for starting up, for maintaining an economical vacuum under varying conditions, and to general simplification of the engine-room and of the main engines themselves, the system of separating the several auxiliaries into independent units is finding favour on all sides. Then, again, the introduction of the steam turbine has created a great demand for condensing plant, consisting of independently-driven air and circulating pumps in combination with surface condensers; of which type the Mirrlees-

Watson 3-crank electrically-driven air pump, constructed on the Edwards dynamic system and illustrated by Fig. 156, represents a typical example of an air pump of large capacity, such as used in electric power stations; in connection with this form

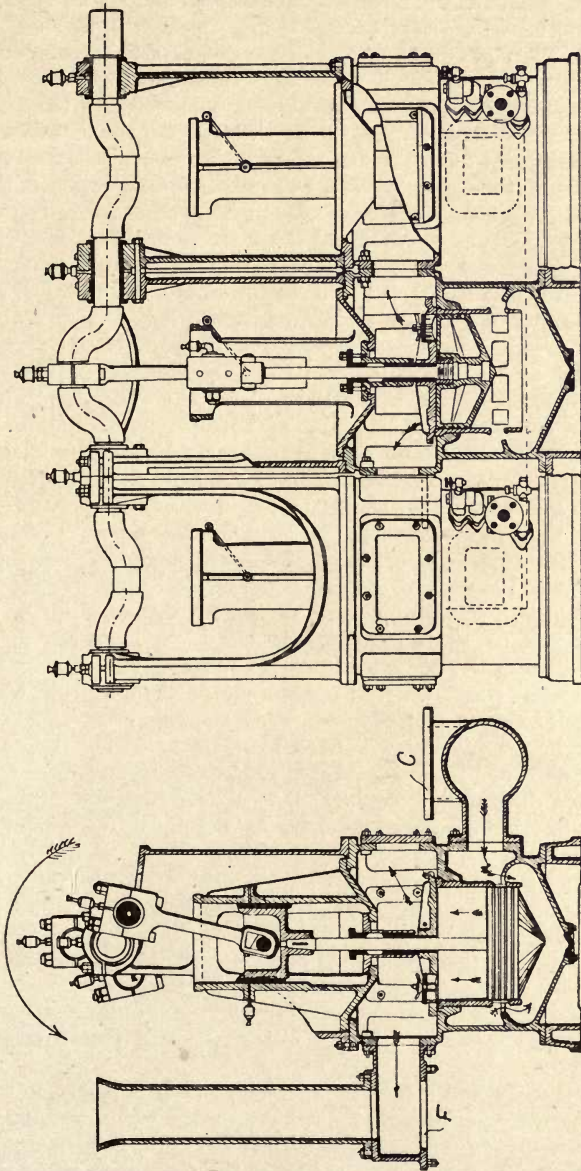

Fig. 156.—Mirreles-Watson Air Pump. Power Station Electrically-driven Type (Edwards Dynamic System).

of pump a circulating pump of the centrifugal type is most generally adopted and arranged to be driven either by an independent steam engine or electric motor, although in many cases one motor or engine is used for the double drive. The

Edwards air pump, as arranged for an independent drive, is probably in more extensive use than any other, its construction and *modus operandi* being as follows:—The water of condensation flows from the condenser into the base of the pump barrel, and it is there dealt with mechanically by the conical plunger on its down stroke, by which action the water is projected silently and without shock at a high velocity through the ports in the barrel arranged just above the conical base, as shown; the rising annular jet of water thus caused to be projected into the barrel above the plunger, on the side ports being uncovered by the descent of the plunger, continues until the plunger closes these ports, which takes place soon after the commencement of the return stroke; the water, together with the air carried in with it, is then caught up by the plunger, and expelled through the rubber-seated outlet valves arranged around the gland-packed cover at the top of the barrel. In common with all other air pumps, as little clearance as permissible under the working conditions should be left between the plunger and the valve end of the barrel at the termination of the up stroke, any air not expelled expanding on the return stroke, and in so doing reduces the capacity of the pump. Thus a perfect pump should have no clearance whatever. In good practice such little space as is found to be unavoidable is filled with water, so that with the exception of that absorbed by the clearance water, the air remaining in the clearance space is reduced to an almost negligible quantity. In the Edwards pump there is no need for either foot valves or bucket valves, consequently no resistance is opposed to the passage of air and vapour from the condenser to the space above the plunger on its descent to a position far enough down to uncover the ports at the side; the air thus has a perfectly free entrance into the barrel, the water, as before explained, being forced in by dynamic action due to the descent of the piston, and the water of condensation deflected by the annular lip shown, so as to continue its course by momentum into the barrel through the side port openings provided. In the Bodmer air pump, which preceded the Edwards improvement, there were two separate sets of port openings for the air and water, consequently in this pump, although there was no valve obstruction, yet its action was not a notable success, owing to the dynamic action imparted to the ingoing water, as in the case of the Edwards pump, not having been utilised to assist in the exhaustion of the condenser.

The important difference in the working of the Edwards pump over the preceding pump of this type, introduced by J. G. Bodmer, and described in the *Proceedings of the Inst. Civil Engineers* in 1845, vol. iv., is mainly due to the substitution of one series of portways for the two used by Bodmer, and to the utilisation of the water flow following the descent of the plunger to prevent back flow from the pump to the condenser during the time occupied by the plunger in closing communication with the condenser; the relative action of the two pumps will be found clearly illustrated by the two sections (Fig. 157). In the Bodmer pump the air was exhausted from a point high up in the condenser through separate port openings, whereas in the Edwards pump only one series of inlet ports is used.

An interesting transition stage between a type of air pump and one which is not dissimilar in action as regards the working of the pump itself to the marine type shown at Fig. 154, where C is the surface condenser, B the actuating beam, P the bucket plunger (provided with valves of the same pattern as used for the inlet and outlet at W) is illustrated by the Borsig air pump at Fig. 155, this being one of a pair worked off a balancing rocking shaft S and lever connecting with the rod K and bucket plunger P. In this pump, water from the condenser flows to a conical base at the foot of the barrel through port openings at the side

when the plunger ascends, thus filling the barrel to the lip of the inlet openings ; on the descent of the plunger this water is displaced to the space above the plunger, together with any air and vapour filling the space between the surface of the water and the under side of the plunger, whence it is all expelled through outlet valves arranged over the plunger, as in the pumps illustrated at Figs. 152 and 154. In this pump, not only is there no foot valve, but there is also seen to be a notable disregard to the minimising of clearance over the plunger, owing

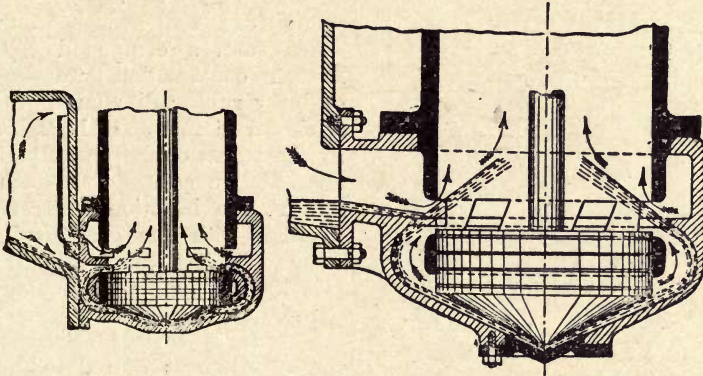

Fig. 157.—Sections showing the Difference in the Working of the Bodmer and Edwards Air Pumps.

to the particular formation of the bucket and outlet valves. However, as the proportion of water to air is from 20 to 30 times greater than in the case of a surface condenser, the effect of clearance is proportionately decreased. Apropos to this clearance effect in jet-condenser air pumps, ordinary simplex or duplex pumps can be used in conjunction with a suitable form of jet condenser, as

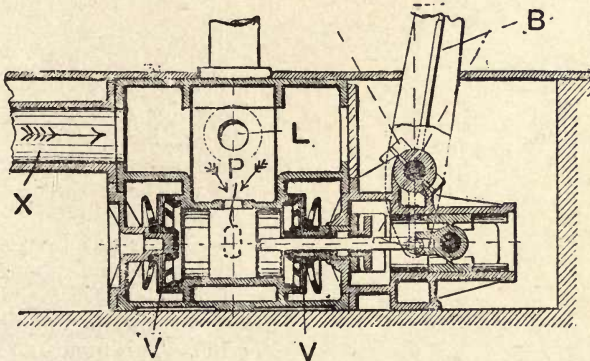

Fig. 158.—Double-acting Valveless Piston Air Pump for Compound Corliss Engine with Jet Condenser.

shown in the Worthington combined air pump and condenser (Fig. 153), where exhaust steam enters at X into a condensing cone of similar construction to the ejector condenser illustrated at Fig. 151, the water injection supplied from C to the jet diffuser J being spread out to the full diameter of the cone N, and is brought thereby into thorough commingling contact with the steam ; the action

of a pump of this kind only differs from that of the ejector condenser before described, in that a vacuum is maintained by a plunger instead of the barometrical column.

In the horizontal double-acting jet condenser air pump shown at Fig. 158 will be noted the same disregard to the importance of reducing the clearance factor to a fine point; in this instance there is no inlet valve, and in this particular resembles the double-acting Worthington pump shown at Fig. 159.

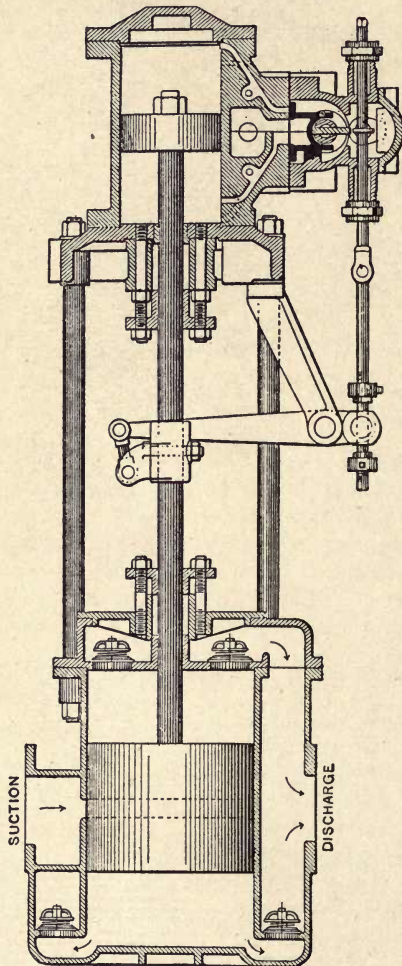

Fig. 159.—Double-acting Valveless Piston Independent Air Pump (Worthington Feather-weight Type).

owing to the large area of the water-sealed flap valves arranged around the base of the pump barrel. In the position shown, the plunger is at its highest point, and uncovers openings for the inflow of water from the condensing chamber above; on the plungers' descent this water is driven out through

Referring first to the jet-condenser pump (Fig. 158), which example is taken from a compound engine of French construction, we find the ordinary rubber disc outlet valves *V* as shown in Fig. 152, through which, by the action of the piston plunger in alternately uncovering the port openings *P*, the injection water from *L*, together with the condensed steam drawn into the pump barrel, is expelled. This type of double-acting pump, although not suitable for exhausting a surface condenser with the arrangement of valves shown, is found to work very effectively when arranged in the form illustrated by the Worthington double-acting pump (Fig. 159); in which the valves are not only water-sealed, but arranged with a minimum of clearance above and below the plunger, and is an example of the lightest known make of independent steam-driven pump; such a pump (measuring 4 inches by 8 inches by 6 inches), only weighing 270 lbs., and is, therefore, specially suitable for steam yachts, torpedo-boats, and light draught steam vessels generally.

As will be gathered, the plunger-controlled method for the inlet from the condenser has been adopted with variations in air pumps of several types, a notable instance of which is the Stott air pump illustrated by Fig. 160. This pump, although shown adapted as a jet condenser, is also suitable for working in connection with a surface condenser, although more suitable for a jet-condenser,

the flap valves shown, the bottom of the plunger being hollowed out to a conical form in order to entrap air, and thus prevent the shock resulting from direct impact with the water in the bottom of the barrel. In the Edwards air pump shock is avoided by making the bottom of the plunger pointed instead of hollow, as in the Stott pump, the water in that case being gradually displaced by the descent of the plunger without shock from the base of the pump through the spacious openings in the barrel above the plunger; there is thus seen to be a similarity in the working of these two pumps, albeit the direction of the flow of the water in the former is exactly opposite to that of the latter.

Some distinctly novel features are comprised in the Zylinderlast double-

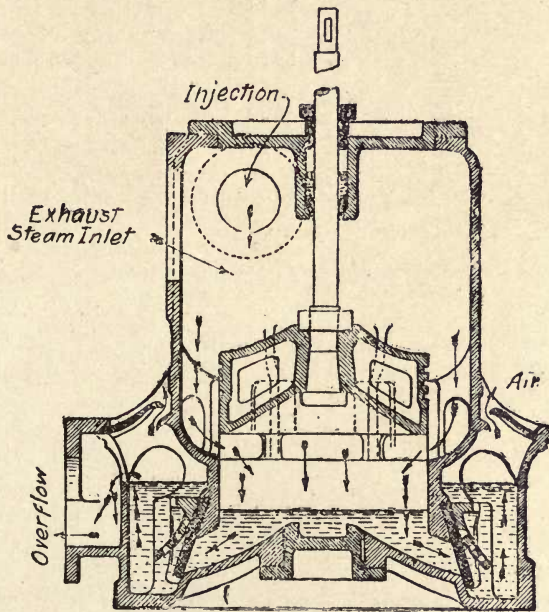

Fig. 160.—Stott Valveless Plunger Air Pump (Benn's Patent).

acting air pump, as will be seen by the sectional illustration (Fig. 161), both inlet and bucket valves are dispensed with, and the pump, seemingly better adapted for use in the vertical form than the horizontal, is also adapted for being constructed as a combined wet and dry air pump to work in connection with a counter-current jet condenser. The Zylinderlast pump resembles to some extent the Edwards and Stott pumps in that a free and unobstructed inflow is obtained, combined with a mechanically-aided discharge. It will be noted that at the termination of the up stroke that inflow takes place through the connection D to the chamber E, and thence by the ports H direct to the base of the pump, and that on the descent of the plunger this is discharged from the conically-formed basin at the bottom of the barrel B by the correspondingly-shaped plunger through the outlet valves F, which are sealed by the water in the surrounding well J. Simultaneously the ports G in the cylindrical extension A of the plunger will register with the ports H communicating with the chamber

E, by which means a second inflow to the well of the plunger takes place direct from the condenser, and, as with the inflow under the base of the plunger, will be discharged through the outlet valves F' arranged in the cover above the plunger, on the termination of the up stroke. The cylindrical extension A of

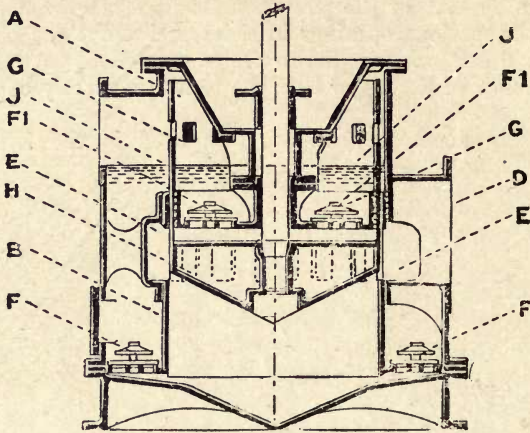

Fig. 161.—Caird and Rayner's Double-acting Air Pumps constructed without Foot or Bucket Valves on the Zylinderlast System.

the plunger passes up between the barrel head C and the upper end of the liner B, an air-tight fit being maintained by accurately-machined and truly aligned

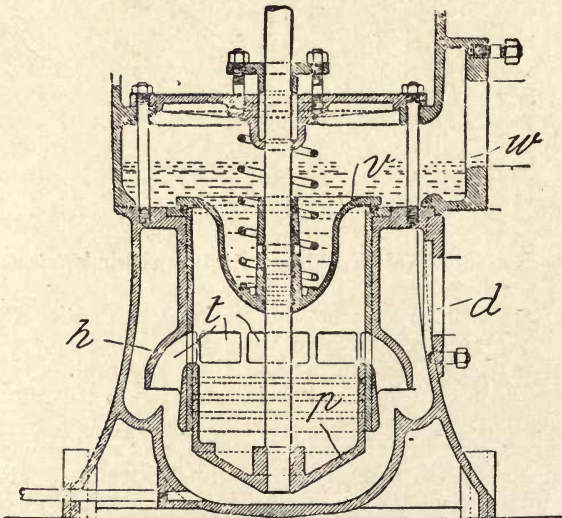

Fig. 162.—Heisler Vacuum Pump.

parts, assisted by water rings in the head piston C, besides which the fit between B and C is sealed on both sides of A by the water in the well J. The principal advantage of this pump is due to its great volumetric capacity, which, it will be noted, is equal to the total sweep of the plunger on both sides, while only

occupying a trifling additional head room to that required by a single-acting pump.

From the foregoing it will be noted that, although foot valves have been eliminated from several single-stage vacuum pumps, head valves are retained as a necessity in both single and double-stage pumps. The Heisler pump, illustrated by Fig. 162, probably approaches as near to the ideal as any other using valves; in this pump only one valve (*v*) of the full diameter of the plunger is used, and this being strung over the pump-rod, is in part mechanically opened and closed, and firmly guided on to its seat, consisting of an inset ring of rubber composition. This pump, as will be recognised, is constructed to operate on the Edwards dynamic principle, but differs from other vacuum pumps of this type in being formed with a deflecting hood (*h*) to guide the water displaced by the plunger (*p*) from the base to enter the pump barrel above, through the ports (*t*), which action, as before explained, has the effect of entrapping the air during that part of the upward movement of the plunger required to close the ports, in addition to a slight exhausting effect caused by the inflow of water at high velocity. But for its dependency on some form of delivery valve, and its limitation to a single stage, the action of this type of pump is as near perfection as can be, there being just sufficient water condensed to enable the hydraulic effect to be obtained. As the splitting of a single valve has often been found to produce an effect sufficient to lower the vacuum several inches, and all valves, however well made, are more or less subject to wear and fatigue, owing to the nature of the stress produced in opening and closing, even on ordinary conditions, an effect that may obviously be greatly increased by wash or a leak in the condenser, it would seem that sooner or later that condenser air-pumps that are dependent on valves of any form will be superseded.

The form of valve most generally used for this purpose is shown in Fig. 163, and represents the best practice for pumps of large capacity, the essential features of which are—that the rubber disc (*d*) be sprung over a brass guide ring (*r*), be provided with a spherically-formed buffer plate, and be made of the right stuff. *Apropos* the trouble experienced with valves, an entirely valveless form of condenser pump has been devised by the writer, in which both head and foot valves are eliminated, and is, therefore, really valveless, although for the matter of that it is customary to use this term for all vacuum-plunger pumps requiring no foot valve. In these designs (*vide* Figs. 164 to 166), the same method has been adopted for obtaining a valveless action—viz., to use a plunger having at one end a cylindrical extension of sufficient length to enable two series of port openings to register with one another towards the termination of each stroke; for instance, on the vacuum stroke (Figs. 165 and 166) the ports (*t*) in the plunger will register at about its termination with ports (*t*) in the pump barrel (*r*), thus

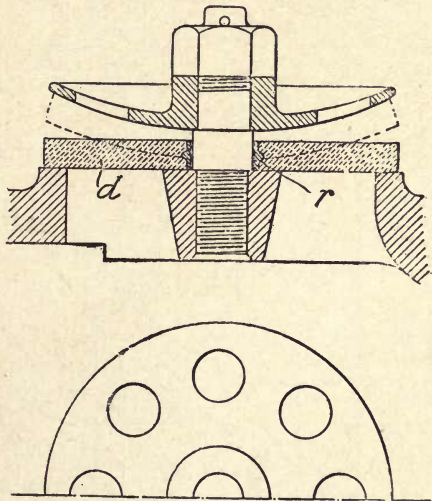

Fig. 163.—Section of Rubber Disc Vacuum Pump Delivery Valve.

placing the partially-pumped-out space between the plunger head (p) and that of the fixed piston (k) in free communication with the condenser connection (d). At the commencement of the return stroke the ports (t) are closed, and the air present from then onwards till near its completion will be compressed and delivered to the hot-well (w) as soon as the ports (t^1) in the plunger register with corresponding ports (t^1) in the pump barrel.

In the direct-acting pump (Fig. 164), designed to work with a 2-stage action,

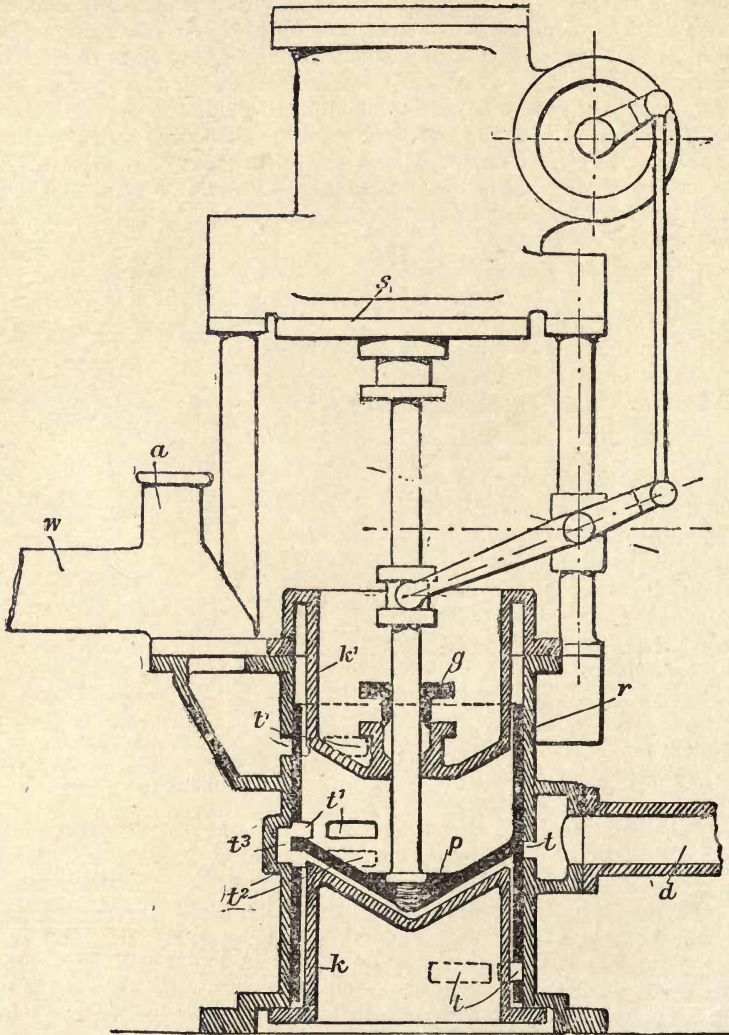

Fig. 164.—Diagrammatic Section of 2-Stage Direct-driven Vacuum Pump without either Foot or Head Valves (*Butler*).

the condenser, as in Fig. 165, is placed in communication with the underside of the plunger at the termination of the up stroke when ports (t) register, and at the same time the contents from the preceding up stroke (which towards the

completion of the down stroke have been transferred to the upper side of the plunger through ports (t^2), connecting way (t^3), and ports (t^1), are forced into the hotwell (w) through ports (t^1) in the plunger, and corresponding ports in the pump-barrel. In this design the plunger-rod passes through a gland (g), sealed by water contained in the cover (k^1), and, needless to add, all the plunger clearances (above and below), as well as each series of portways, are also effectually water-sealed.

In the two single-stage pump designs (Figs. 165 and 166) both the working

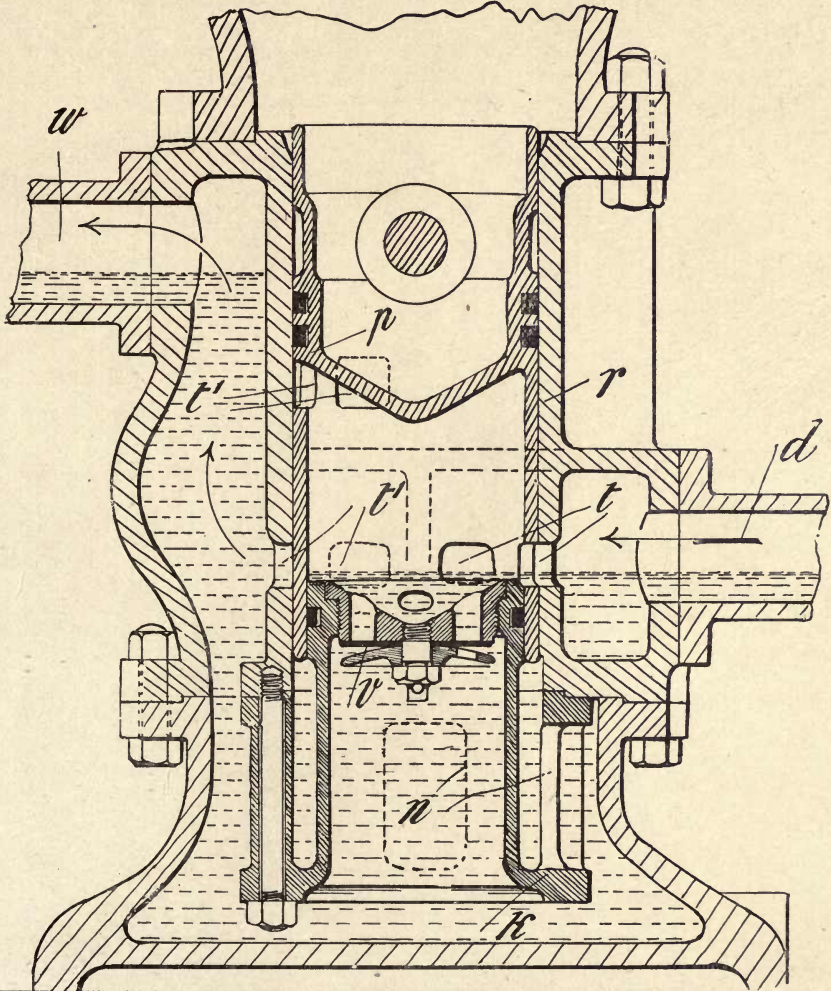

Fig. 165.—Single-Stage Condenser Vacuum Pump without either Inlet or Outlet Valves (Butler).

and fixed pistons are provided with packing rings, and the annular space for the plunger extension placed in free communication with the surrounding water by passages (n); also, in order that any inflow of water to the pump (such as may be due to flooding of the condenser) shall be carried off, a valve (v) is fitted

to the cover head, where its function is simply to serve as a relief valve, and will consequently only come into action at such times. The volumetric displacement of the pump equals the area of the fixed piston or cover head, plus the

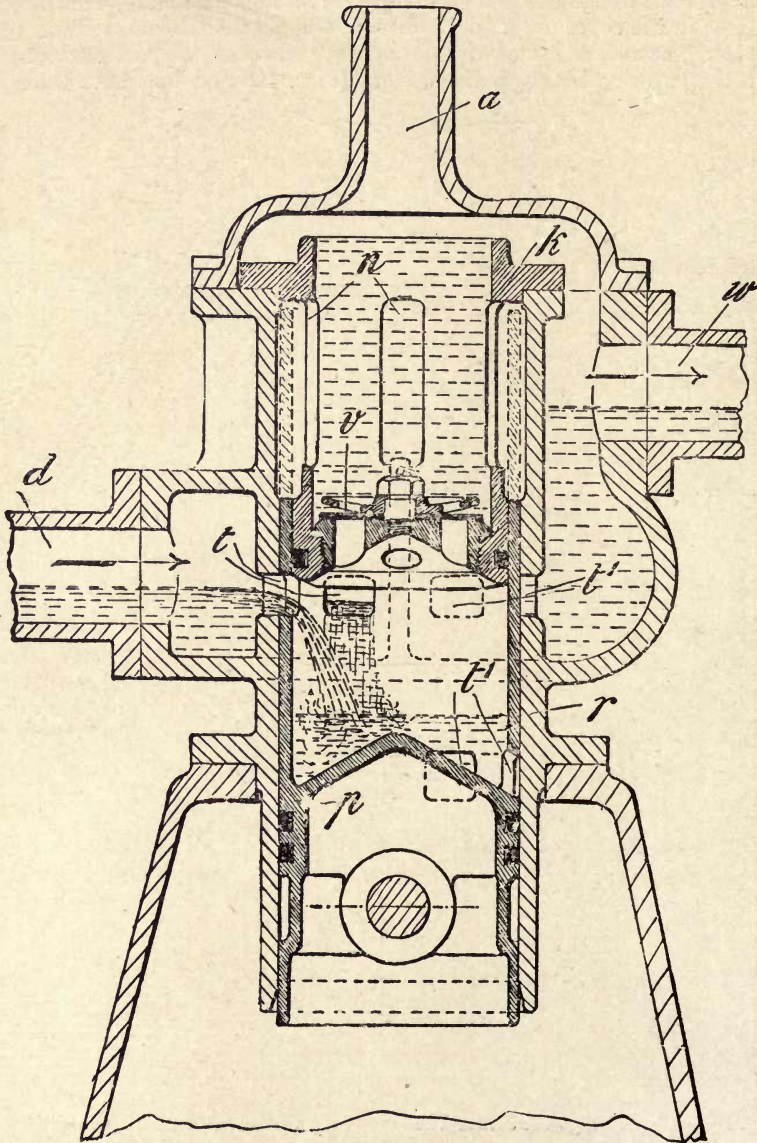

Fig. 166.—Inverted Design of Valveless Condenser Pump.

distance separating the two series of port openings, but may be doubled by arranging two single-acting plungers (actuated by cranks at 180°) to work in series, in which construction the manner of obtaining a 2-stage action is

analogous to that of the double-acting pump already described, and in either case enables the pump to maintain a low vacuum with less volumetric displacement than would be possible working single-stage, owing to the reduced effect of air absorbed by the clearance water.

Combined dry and wet condenser pumps for this reason have a greater capacity than those of the ordinary type—*i.e.*, provided the clearance between the valves and plunger at the dry air end of the pump is negligible, otherwise the remedy may be worse than the disease. This will be made clear by the examples (Figs. 167 to 169), in the first of which the plunger is fitted with valves, and the condensed steam discharged on the down stroke into the hot-well end of the pump through the trunk, when on the up stroke the air entering through the central series of openings is discharged through the upper series of valves into the delivery chamber. In the second example (Fig. 168), a plain double-acting plunger with flat ends is used, which just before the termination of each stroke

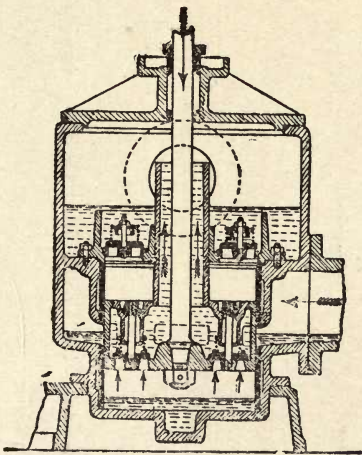

Fig. 167.—Paxman Combined Dry and Wet Air Pump.

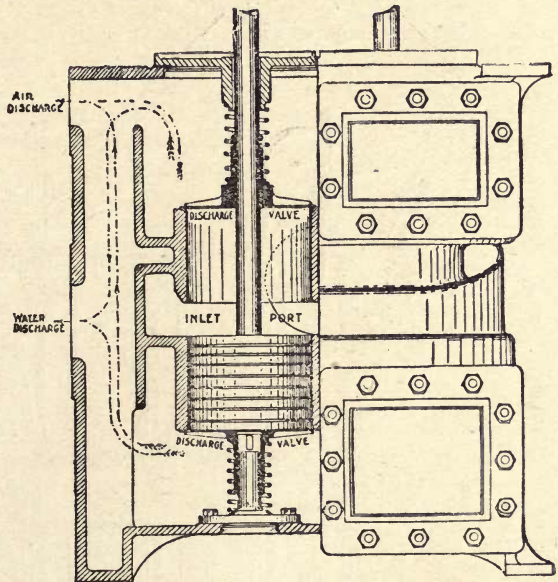

Fig. 168.—Fraser Combined Dry and Wet Air Pump.

contacts with a valve held in position by being strung over the plunger-rod, as in Fig. 162, but in this pump the valve at each end is mechanically operated, and, therefore, can be held on to its seat by a strong spring, and the clearance reduced to a negligible quantity, which, although of small importance to the water end of the pump barrel, is exactly the desideratum required for the air-delivery end of a vacuum pump.

Obviously, if a condenser having separate dry and wet exhauster pumps be provided with some practical means for cooling the air pump, the temperature of the condensed steam delivered to the hot-well for a given vacuum may be higher, in addition to which advantage the volume of circulating water may be less. In the condenser exhauster, known as the "Weir Dual Air Pump," this method of increasing the efficiency of the condenser plant is used, but not by

jacketing the pump barrel and inlet pipe, as has been tried with poor results (owing to the particularly low conductivity of rarefied air, but by a separate closed circuit injection and small auxiliary cooler. This injection, as shown

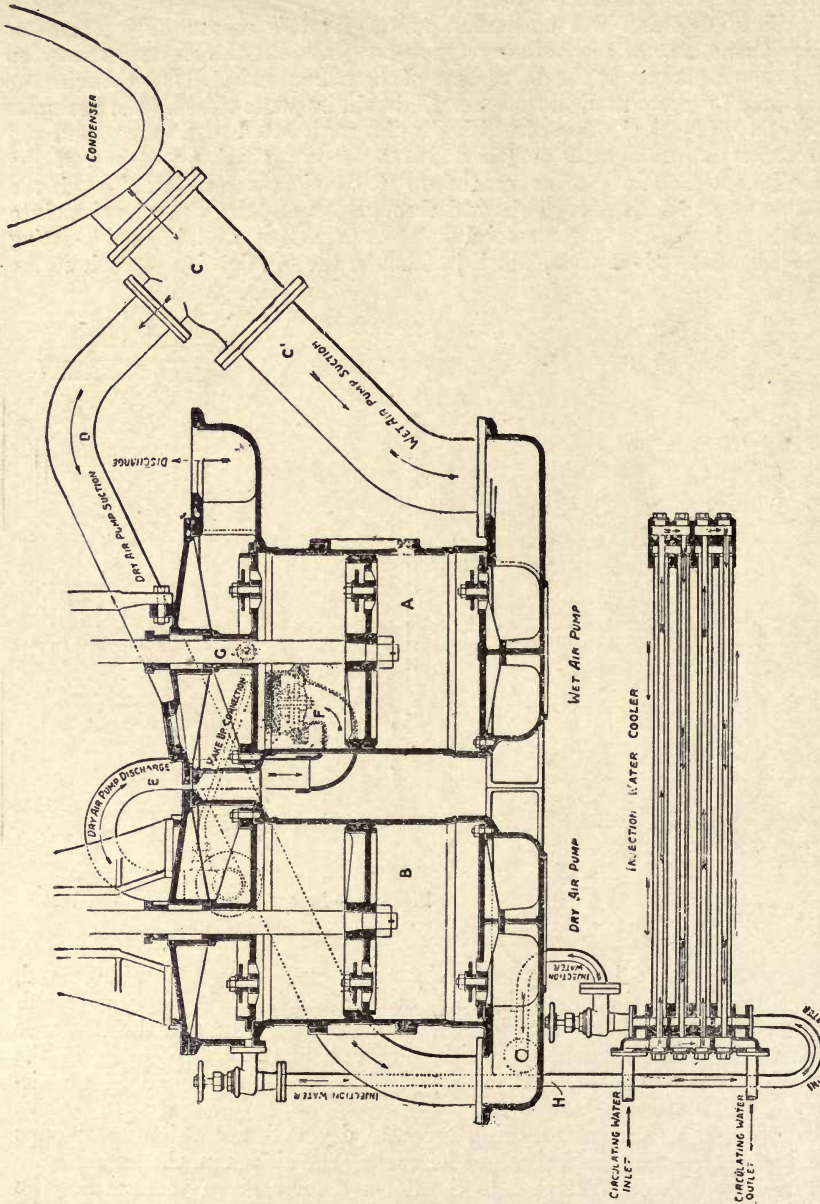

Fig. 169.—Sectional Arrangement of the "Weir" Dual Air Pump, showing Cooler and Condenser Connections

in the arrangement (Fig. 169), illustrating this system also serves as sealing water for the dry air pump B, which, like the wet air or water pump A, is worked on the 3-valve 2-stage system, and as the air is delivered below the head valves

of the wet pump and at a pressure not higher than 20 inches of vacuum, the sealing water can only absorb but a proportionately small amount of air, and as this injection or sealing water is maintained at the temperature of the circulating water by the cooler, the method adopted in this dual air pump system enables the wet or water pump to exhaust water of condensation at approximately the steam temperature, while at the same time the dry pump will be able to exhaust the air and vapour at the volume and temperature conditions imposed by the temperature of the injection water.

Further, as in this system the dry air pump works at less than half the pressure range, and its contents are densified or decreased in volume by the cooling action of the injection water (which circulates continuously and is never subjected to atmospheric pressure with consequent aeration), the capacity of a pump constructed to work on the dual system is practically equivalent to a pump constructed to exhaust in three stages, but without the cooled injection water.

Referring to the illustration, the water pump A is actuated direct from an overhead steam cylinder, and the dry pump B, having less work to do, is connected thereto by a beam and link motion; one pipe C connects the bottom end of the condenser with the foot valves of the water pump A, and a separate and smaller pipe D with the foot valves of the air pump B. The most important differentiation in this, as compared with an ordinary twin pump, consists in the pump B discharging through the return pipe E through a spring-loaded valve F into the wet pump at a point below its head valves, this delivery valve F being loaded to maintain a pressure in the dry air hot-well at about 8 inches above the vacuum in the condenser, which difference is necessary to cause the injection water to circulate freely through the annular cooler and pipe H, connecting it with the chamber above the head valves of the air pump. The valve G is only opened for a minute or so to enable the vacuum to draw in a supply of sealing water from the hot-well of the wet pump at starting, after which this water continually circulates through the dry air pump and the cooler below.

A totally different method is used in the combined vacuum and injection pump illustrated by Fig. 170; this pump, known as the Connersville Cycloidal, really depends entirely on the hydraulic effect produced by the pair of 3-lobed rotary plungers (*p*) for its capacity as a vacuum pump, and will, therefore, be seen to require a very considerable volume of sealing water if used simply as an air pump for a surface condenser—equal, in fact, to the displacement of the two rotary plungers, multiplied by the speed necessary to beat down the water from the air inlet ports (*t*), the resultant cavitation produced constituting the volumetric displacement of the pump. As shown, it is arranged in combination with an injection condenser, in which the steam entering at (*m*) passes down the converging nozzle (*v*), where it is surrounded by the injection water entering at (*n*). Air is drawn off through two pipes (*r*) from the annular chamber (*d*) formed by the condenser nozzle (*z*) and enlarged downtake, and is delivered to the pump at two side inlets (*t*), where at each beat of the plunger lobes a cavity is formed, and by this means the air is entrapped and delivered to the atmosphere through the outlet (*k*) for the injection water. In its relation to a plunger pump in point of capacity there would not appear to be a greater volume of water used for producing the required hydraulic exhausting effect than is necessary for condensation purposes; for instance, a pump having a displacement of 9 cubic feet per revolution, and running at 108 revolutions per minute (which is equal to practically 970 cubic feet per minute), is capable of maintaining a 27.5-inch vacuum with a 29.4-inch barometer, in an injection condenser supplied with 40,000 lbs. steam per hour, the injection water entering at 66° and leaving at

96° F., which is equal to 1.5 cubic feet per pound of steam condensed per hour; the weight of injection water is, however, much greater than generally used in a plunger pump condensing plant, as it exceeds the weight of steam condensed by more than 80 times. The volume of sealing water can, however, be reduced considerably by causing it to be projected in a divided stream at sufficiently high a velocity to overcome the pressure of the atmosphere, either through a single-exhausting nozzle, as adopted in the Leblanc hydraulic vacuum pump (Fig. 171); or, through a series of nozzles, as in the Rees rotary vacuum pump (Fig. 172). In the first-named pump a turbine wheel D is rotated at a velocity capable of projecting the sealing water supplied from the intake B to the nozzle C to a height of about 50 feet in a number of thin sheets E. The wheel runs in a closed

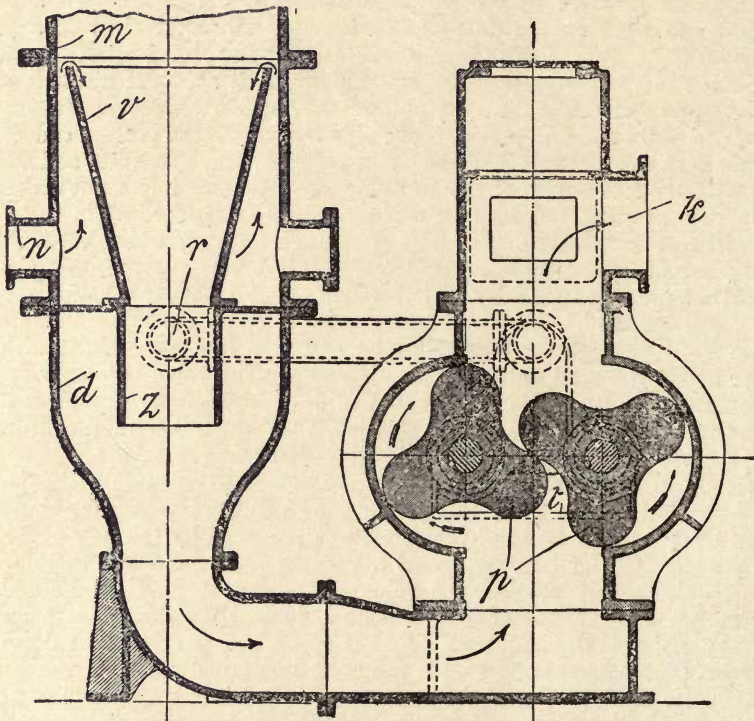

Fig. 170.—Cylindrical Rotary Vacuum Pump.

race, and is fitted with a series of blades or spoons similarly to that used in a turbine, but, instead of running as a motor and converting the kinetic energy of the water into power, the wheel is rotated in an opposite direction, thus causing the water to be projected in a divided jet (of cross-sectional area equal to the nozzle C, plus a certain increase in a tangential direction due to the higher peripheral than radial velocity imparted to the water) down through a nozzle, as used in an ejector condenser. In the Rees vacuum pump sealing water is whirled from an impeller wheel A, as used in a centrifugal pump, but, instead of issuing in an unbroken circumferential stream, the water is projected radially in a number of small jets C from holes B arranged in pairs at such an angle that the jets meet before issuing from the impeller at D. Surrounding the impeller

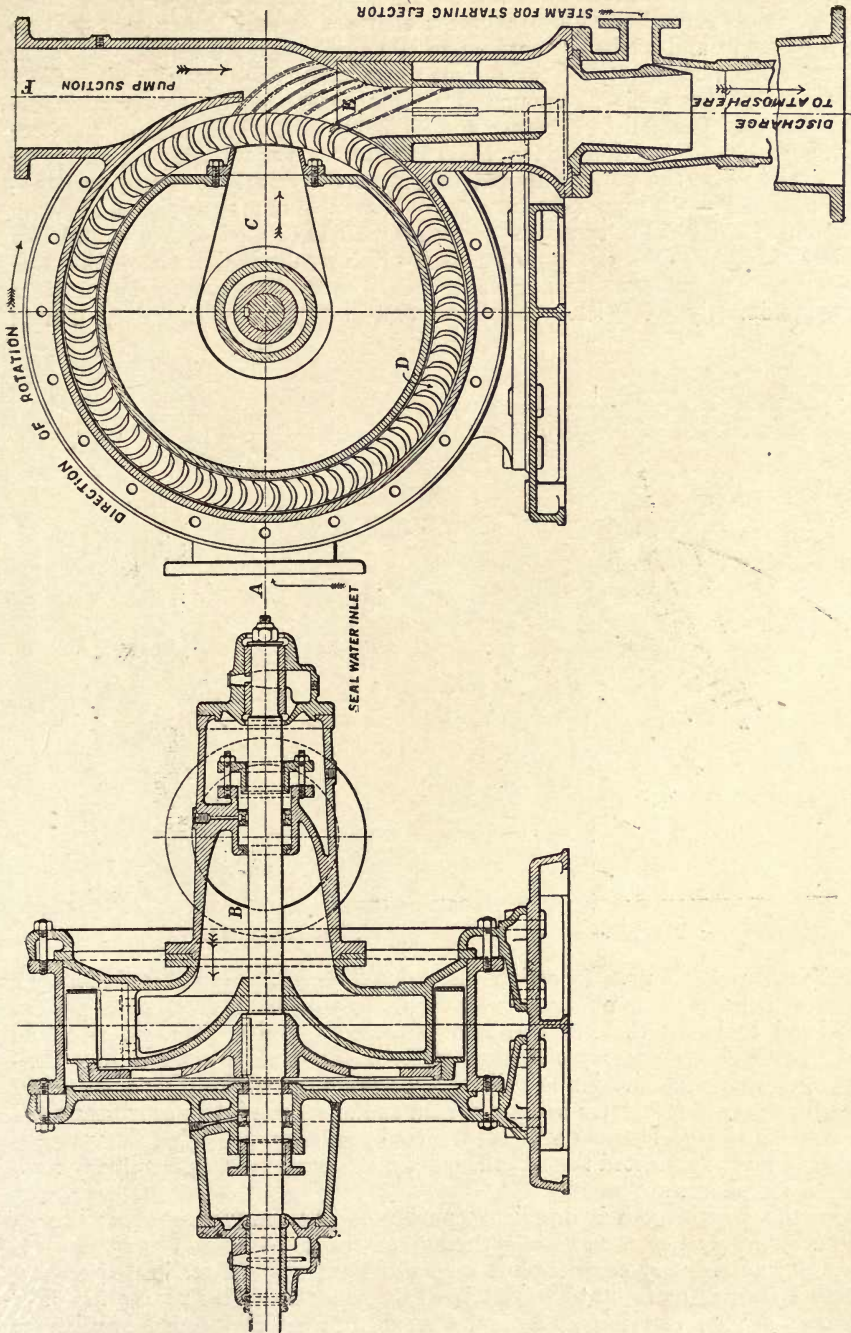

Fig. 171.—Leblanc-Westinghouse Rotary Hydraulic Vacuum Pump.

is a diffusion ring, provided with vanes E, for the purpose of directing the outflow from a tangential to a radial direction, whence the sealing water and with it the entrapped air is discharged into a vortex chamber V, and thence to a well, to be used again and again. According to *The Engineer*, a Rees rotary exhauster pump, when running at 800 revolutions per minute and absorbing 20 B.H.P., is capable of maintaining a vacuum of 28 inches with 6,000 lbs. steam per hour; 26 inches with 15,000 lbs. of steam; and 25 inches with 20,000 lbs. of steam per hour; and when accelerated to 1,000 revolutions per minute and absorbing practically twice the power required to run at 800 revolutions per minute—viz., 40 B.H.P.—the same exhauster pump is capable of maintaining a 28·5-inch vacuum with 6,000 lbs. of steam, 28 inches with 14,000 lbs. of steam, and 26·5 inches with 20,000 lbs. of steam per hour, which results indicate a considerable elasticity. The volume of sealing water circulated at 800 revolutions per minute is approximately 6,000 lbs. per minute, and at 1,000 revolutions per minute

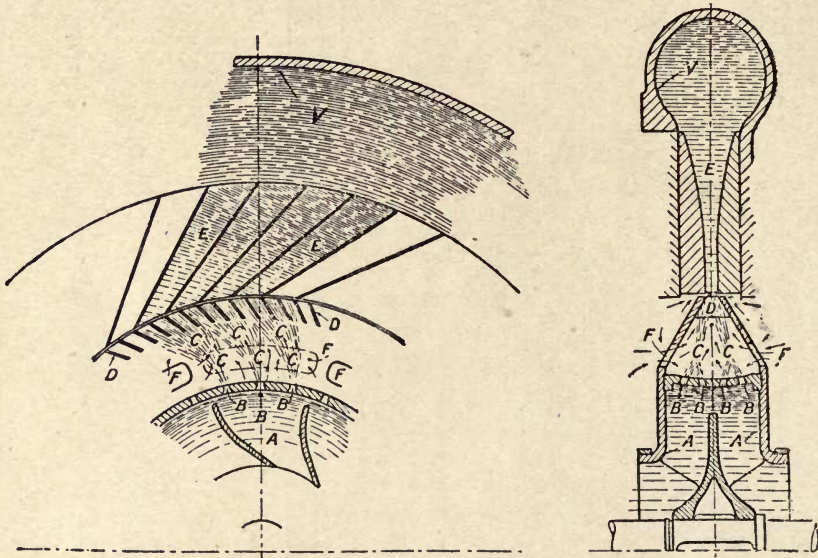

Fig. 172.—Rees Centrifugal Ejector Vacuum Pump.

10,000 lbs. per minute. In action the diffused water spray radiated from the series of holes B in its passage outwards carries with it air entering at F from the hood enclosing the impeller, and connected up with the condenser, the impeller drawing its supply of sealing water on both sides from a pipe continued down to the circulating well. Before starting the hood is either filled up with water (a foot valve being provided at the suction inlet), or is exhausted by a steam ejector, in the former case on the impeller being rotated the water in the hood is soon extracted through the holes F when the pump immediately commences to exhaust air.

In the Worthington hydraulic vacuum pump an exhausting effect is produced by a water jet in its passage through an ejector tube; in this pump (*vide* Fig. 173) an ordinary centrifugal is used to force the jet of sealing water at a pressure equivalent to 50 to 60 feet head through the ejector nozzle, in which there is a plug carrying at its end a small differentially bladed impeller or

transforming wheel, used for the purpose of breaking up the jet in order that it may by cavitation effect carry with it a greater volume of air down the exhauster tube. As in other vacuum pumps of this class, the sealing water is circulated over and over again, and maintained at a working temperature by the inflow to the well of a small percentage of cold water, the water of condensation being discharged from the condenser into the hot-well by a separate pump. In regard to the volume of sealing water required, a 12-inch pump, capable of circulating 400 cubic feet per minute against a head of 50 to 60 feet, is capable of maintaining a vacuum of 26 inches with 50,000 lbs. of steam per hour; or, in other words, an ejector run on this system has an extracting capacity of 500 cubic feet per minute, and is, therefore, equivalent to 0.06 cubic

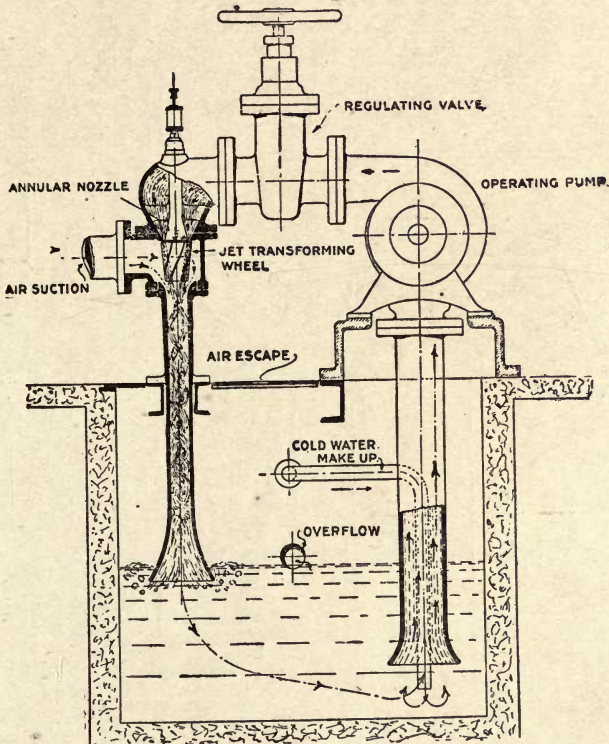

Fig. 173.—Worthington Hydraulic Ejector Vacuum Pump.

foot per pound of steam, which is approximately the rating allowed with plunger pumps. The power required is about the same as that for a Rees rotary of equal capacity, a Worthington hydraulic vacuum pump capable of maintaining a 26-inch vacuum with 50,000 lbs. of steam absorbing about 55 B.H.P., and a Rees rotary vacuum pump about 20 B.H.P., when dealing with 15,000 lbs. of steam under similar vacuum and temperature conditions. The volume of sealing water required is, as would be expected, slightly higher in the rotary ejector than in the rotary diffuser pump, but is much less than that of the cycloidal rotary (Fig. 170), which, as before explained, needs as much as 80 lbs. per pound of steam, that for the rotary ejector (Fig. 173) being 30 lbs., and the

volume used in the rotary diffuser pump (Fig. 172) 24 lbs. per pound of steam, from which it might at first sight be expected that the latter could be run with less power, the difference absorbed being really accountable by the increased hydraulic resistance due to the greater diffusion of the sealing water.

In another form of condenser exhauster operated on the hydraulic system,

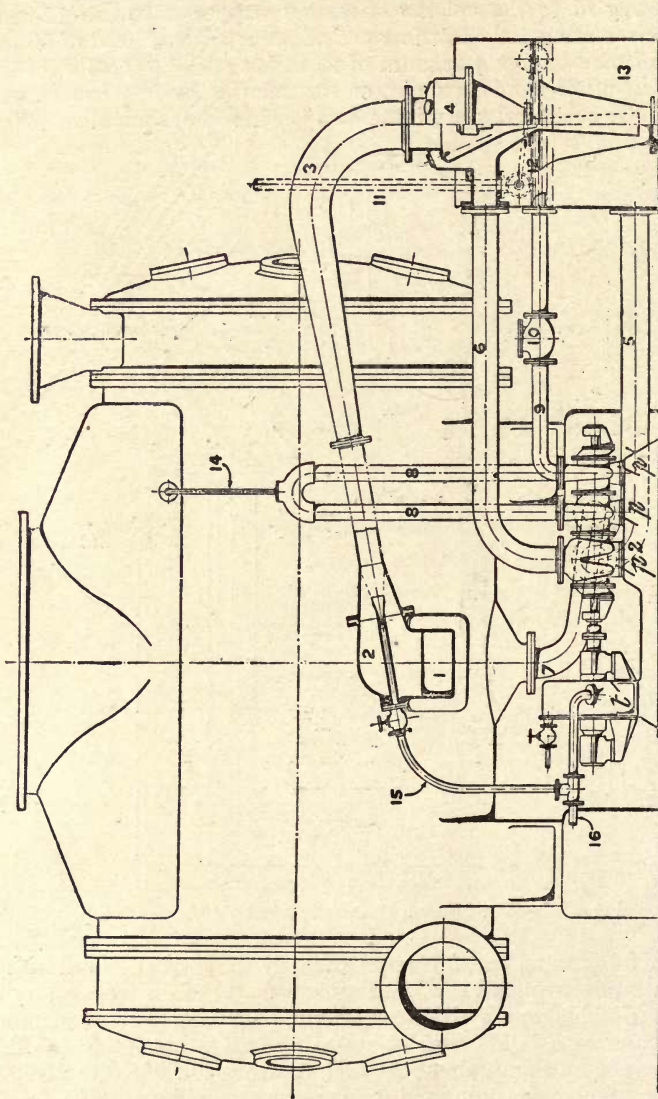

Fig. 174.—Elevation showing Ejectors, Turbine Pumps, and Condenser, arranged on the Kinetic Vacuum System.

and known as the kinetic air pump (Fig. 174), there are one or two important differences—*e.g.*, the pump can be worked on the condenser floor, and does not require an independent supply of sealing water. According to this system air is drawn off at (1) from the surface condenser, known as the “contraflo,”

and supersaturated with steam supplied by the pipe (15) from the steam turbine (*t*); this exhaust steam, together with the air from the condenser, is conducted by the pipe (3) to the ejector condenser (4), the water of condensation in the tank (13) being used as the injection water, and circulated through the ejector condenser (4) along the pipes (5 and 6) by the centrifugal pump (*p*²). Water of condensation is drawn off from the condenser by the centrifugal pump (*p*), arranged to work at condenser pressure, so as not to require a suction head, and is delivered from this pump through the syphon (8)—placed in pressure connection with the condenser by the pipe (14)—to the centrifugal (*p*¹), whence the water is discharged along the pipe (9) to the hot-well (13), and is here maintained at the level shown by the float valve (12) controlling the supply to the boiler feed pump along the pipe (11). It will be gathered, therefore, from this that all the heat other than that lost through radiation is actually accounted for, recognising that the steam exhausted from the turbine (*t*) is, after being further utilised in the ejector (2)—in discharging air from the surface condenser to the ejector condenser (4)—all condensed. Curiously, each of the twenty or so plants on this system, and representing some 35,000 H.P., have been supplied to electric power houses, although it would seem that, being able to work all on one level, the system would be more specially adapted for turbine installations at sea.

In place of the steam ejector (2) and exhauster condenser (4), a twin-cylinder 2-stage 3-valve exhauster pump is used in an amplified development of the "contraflo" condensing system when required to deal with large volumes of steam and at the same time maintain the low vacua so necessary for economic working of turbines. This, known as the "Bi-therm" air pump, really comprises two separate 2-stage 3-valve pumps, as they are separately connected to the condenser; the peculiarity inherent to this system consists in arranging the pump connections to the condenser at two levels, so that one pump normally draws only water, and the other air, and is provided with a constant circulation of cold sealing water from a cooler located either in the base of the condenser or independent of it, by which means the sealing water can be maintained at a lower temperature than the condensate, and comparatively free from air. The principal feature, however, differentiating this air pump from others consists in arranging the respective pumps that when either pump is overloaded, the other automatically comes to its relief, and under such conditions both can work as ordinary air and water pumps, and may be simultaneously cooled.

One of the several methods that have been proposed for utilising the momentum of water for exhausting and compressing air is illustrated by Fig. 175; this hydraulic vacuum pump being designed to work with an intermittent slinger action, in which respect it promises a higher efficiency than a pump depending on the exhausting effect of a continuous jet. Hitherto the best results that have been obtained from a momentum vacuum pump actuated by hydraulic power, when measured in terms of the water set in motion for a given vacuum effect, ranges from 0.5 to 2 cubic feet of water per cubic foot of free air. In this pump the sealing water (which may be either taken from the condenser or from an independent source) is projected from an impeller wheel of special construction in the form of slugs—*i.e.*, with an interrupted jet—which in its passage at high velocity through an elongated ejector tube acts as so many plungers. In such a pump, for example, having an impeller with vanes (*v*) shaped to impart to the water a maximum tangential velocity with a minimum radial velocity—*i.e.*, a contrary effect to that required in a centrifugal pump for the purpose of projecting the water in an interrupted jet:—There are provided (in the impeller) one or more pairs of peripheral openings (*m*), a nozzle (*n*)

constructed in the form of a parabolic curve, and a converging cone (*t*), in length sufficient to absorb the momentum of the water, and to ensure an effectual seal between the atmosphere and the condenser. In action the sealing water is caused to circulate from a tank (*w*), which may serve as the hot-well, to the pump (*p*) in a closed circuit by the connecting pipe (*s*), excess water of condensation as it is received from the condenser by the connection (*d*) overflowing at (*f*) through a pipe leading to the suction inlet of the boiler-feed pump.

In regard to capacity, a pump having an impeller, 17 inches diameter, provided with four openings, 3 inches wide by 5 inches long, and run at 1,000 revolutions per minute, will project an interrupted jet, equivalent in volume to approximately 1,200 cubic inches, and at a velocity of 50 to 60 feet per second, into the ejector cone, such jet representing a *vis-viva* or potential energy equivalent to 3,300 foot-lbs. per second, and consequently will absorb 6 H.P. theoretical; now, as these 66 separate jets per second, in being projected into a converging cone, having a diameter of 6 inches at the condenser end, will displace approximately 6 cubic feet per second, or 360 cubic feet per minute (allowing a space

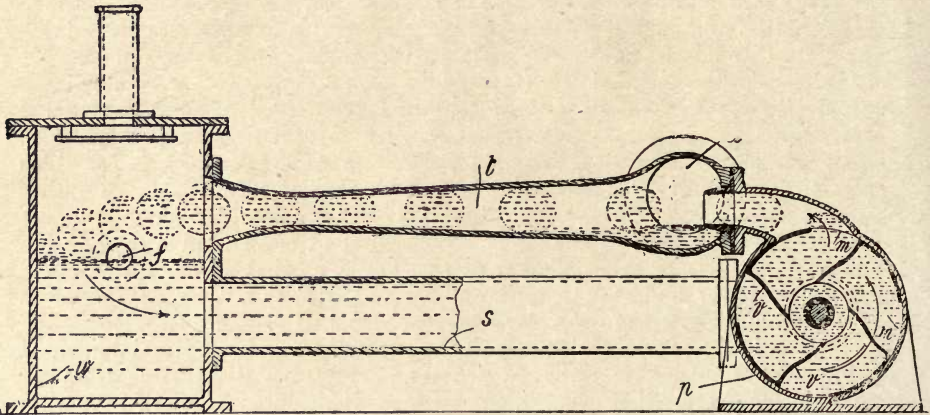

Fig. 175.—Rotary Hydraulic Ejector Vacuum Pump, with High-duty Entraining Action (*Butler*).

of 5 inches between each jet, and considering that a displacement of 360 cubic feet per minute is equivalent to 33,000 lbs. of steam per hour with a 26-inch vacuum), it will be seen that the power required (even allowing for a pump efficiency as low as 40 per cent.) is only 15 B.H.P., which is less than one-half that of any other vacuum pump.

In taking a retrospect of the practice followed and course of development in the design and working of condenser vacuum pumps, it is evident, apart from the excellent results obtained from carefully-designed and well-made plunger pumps, that great importance has long been attached to the elimination of valves, and, in fact, all possible sources of air leakage; and, further, considering the surprising results obtainable with rotary pumps operated on the hydraulic principle, it is only a question of time for this class of vacuum pump to be universally adopted in all power installations depending on surface condensers, for the sufficient reason that it is not only valveless, compact, and absolutely silent in action, but elastic and reliable beyond any other form of vacuum.

CHAPTER XIV.

**HYDRAULIC POWER PUMPS, RAM PUMPS, AND STEAM, AIR, AND GAS
POWER DISPLACEMENT PUMPS.****Hydraulic Power Pumps.**

THE first instance on record of hydraulic power being applied for the distribution of water for domestic purposes on anything approaching a notable scale was towards the close of the sixteenth century, at which time the City of London instructed one Peter Morice to put down two sets of pumps and undershot water-wheels between the first two arches of old London Bridge. At this period, towns that were not situated so as to be provided with a water supply by means of aqueducts fed from the neighbouring uplands, mostly obtained their drinking water from draw-wells or wells fitted with the primitive form of lift pump, the art of plumbing at this time having attained to greater importance perhaps than any other branch of mechanical engineering. Cast-iron pipes not being in use, and lead pipes too expensive for distributing mains, the ancient practice of using tree trunks for this purpose was adopted for London's first water-distribution system. Elm trees had for long been known to be the most durable wood, and the trunks were bored longitudinally to an internal diameter of from 7 to 10 inches, according to the level at which they were to be laid, the smaller bores being used for the deepest levels on account of their greater strength; bored trunks, known as pump-trees, were even used as rising mains in mines. In this connection, it is noteworthy that cast-iron water mains were not used until the commencement of the nineteenth century, wooden pipes continuing to be in use by the New River Company down to as recently as 1820, and the low-level service fed on the intermittent supply system down to the seventies, it having been conclusively realised by this time that the consumption of water under constant supply, instead of increasing enormously as expected, actually resulted in a loss of considerably less magnitude than when the supply was intermittent.

Single-acting leather-packed bucket plunger pumps, actuated by wind, water, and animal power, were in common use before the introduction of steam for many purposes, including the drainage of mines; and hydraulic power was used wherever a supply of water at a sufficient head to work a water-wheel was available. It is noteworthy to add that unwatering pumps can in many cases even now be worked at less cost by hydraulic engines than by steam power applied underground, this being partly accounted for by the losses incurred in transmitting steam power through a long pipe line owing to condensation. For this reason, deep-level pumps situated along an adit in such a position as to be impossible for being worked by mechanical connection with an overground engine are often either driven by electrical or hydraulic transmission. This in the latter case consists of a set of steam-driven hydraulic pumps connected up to an hydraulic engine and pump below, the method of transmission for

short distances being the water-rod system, consisting of two pipes, through which the motion of the generator plunger is transmitted to the motor plunger, each plunger consequently being caused to synchronise with the other. For distances where the momentum caused by the weight of the water column would make this method impracticable, power can be transmitted by a single line, the exhaust from the engine either being raised to the surface by the pump, or in what may be probably a better practice, a separate return pipe is used, in which case the power water can be kept free from the impurities of the mine water, and, what is still of further advantage, the water in this way retains some of the lubricant used on the plungers. An essential feature for the successful working of a pump actuated by an hydraulic engine, whether the power is transmitted from a generator at the surface or by a pipe line connecting up some conveniently situated reservoir, is the use of a properly charged and proportioned air chamber on the engine to absorb the momentum of the water column at each stroke; bearing in mind that the loss of energy arising from fluctuations of velocity in the driving column is directly proportional to the weight of the driving column, and, therefore, to its length, so that when the height of the column is inconsiderable compared with its length, and, therefore, its power small compared with its weight, the percentage of loss from this cause may materially reduce the efficiency of the engine.

In proportioning the diameters of the engine and pump plungers, a margin of from 30 to 35 per cent. is usually allowed for friction of the engine, pump, and pipe lines when properly laid, and of not considerable length; thus,

$$\left(\frac{P}{H}\right) \times \frac{M}{F} = 65 \text{ per cent.};$$

where H = area of engine piston,

P = area of pump plunger,

M = head against pump in feet,

F = head of power water in feet.

As an example, the diameter of cylinder for an engine actuated by water pressure resulting from a head of 700 feet to drive a pump having a plunger 12 inches in diameter, and forcing against a total head of 200 feet, will be:—

$$\frac{112 \times 200}{700} \times \frac{100}{65} = 8 \text{ inches.}$$

The plunger speed found suitable for the pump is usually good enough for the engine, 12 double strokes per minute being easily attained with a stroke of 3 feet; the capacity of a pump of this size would be about 21,000 gallons per hour, less some 9,300 gallons per hour exhausted by the engine, leaving a net useful effect of from 11,000 to 12,000 gallons per hour. With power water obtained at a greater pressure the net capacity of the pump will be greater; and *per contra* with a reduced pressure of power water or increased head against the pump, a condition may be arrived at where there will be little or no advantage.

The example illustrated by Figs. 176 and 177 affords a fairly representative construction of a combined hydraulic engine and mine pump, and is, it will be noted, not dissimilar from the direct-acting steam pump, excepting that the engine cylinder is much smaller. Referring to the drawings, H is the power cylinder and P the pump, having suction intake S and delivery outlet D, together with rubber or leather-faced valves accessible from the covers R, and shown in detail at L. The engine is controlled by a pilot slide valve through

the tappet gear T; the valve chest V is shown in section at Fig. 177, where E is the inlet for the power water and X the outlet, V and V¹ being two auxiliary cylinders for the valve pistons G and G¹, the movements of which are controlled by the pilot slide valve S through the ports shown. The exhaust valves N and N¹ are annular, and have at the bottom end two valve beats, one for the inlet

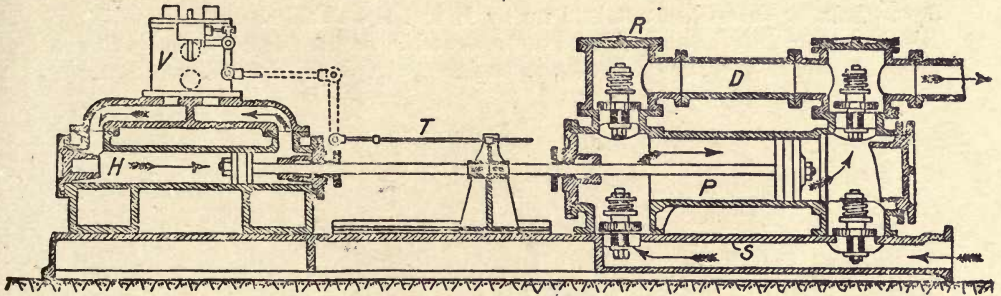

Fig. 176.—Davey Hydraulic Mine Pump.

valve M or M¹, and one on the outer edge controlling the escape of water from either end of the power piston to X, the upper ends of the exhaust valves constituting actuating pistons, which fit in the auxiliary cylinders V and V¹.

As the annular valve descends, the outside beat closes communication to the exhaust, and the inlet valve M, in rising against the inner beat, closes the

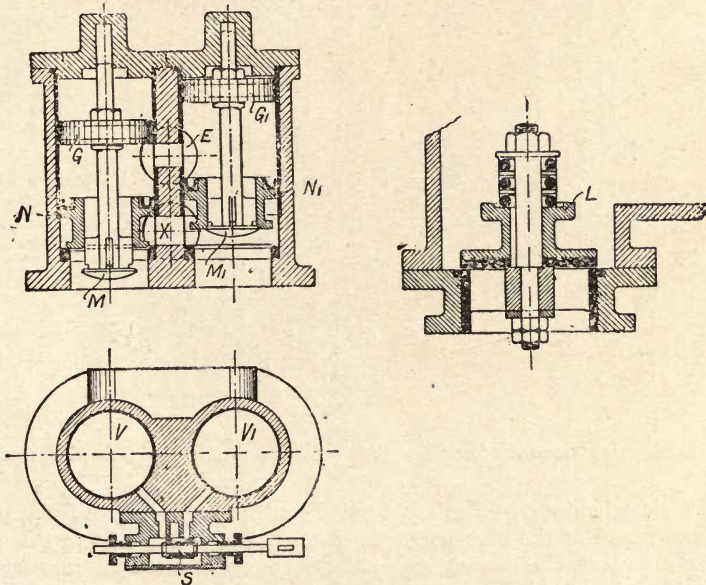

Fig. 177.—Details of Engine and Pump Valves for Hydraulic Mine Pump.

supply. The valves M and M¹ are controlled by the pistons G and G¹, the bottom face of which is, for both, constantly under the pressure of the power water, while the top face is exposed alternately to the pressure from E and to the

pressure at X by means of the pilot S and tappet gear T. The valve M is shown open for driving the engine piston H in direction of arrow, and when the forward stroke is completed, the slide S will open communication from the top of G to X, when valve M will be caused to close against N and to lift it; thus opening the forward end of H to X. The action of the slide will now cause G¹ to descend, the pressure between the pistons G and N, and G¹ and N¹ always forcing N and N¹ downwards, so that when not held up by M and M¹, as shown in the position N¹, the exhaust valve will be forced down as at N. By this sequence (the valve being known as the Davey hydraulic engine controlling gear) either pressure

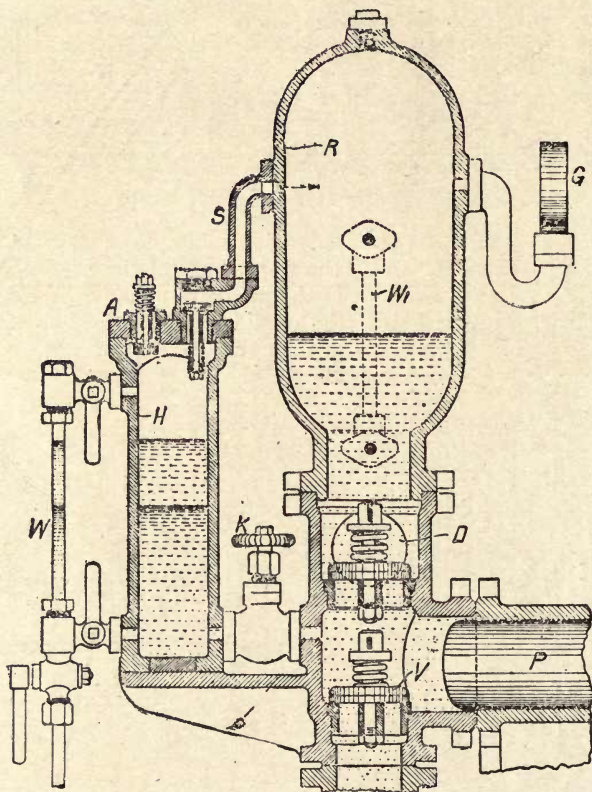

Fig. 178.—Wipperman Air Chamber Charger for Hydraulic Engines and Pumps.

valve must close before either exhaust valve can open, the action being beautifully smooth; and as the opening of the exhaust valve depends on the closing of the pressure valve, this cannot open until the exhaust is cut off, thus avoiding the possibility of slip, which, together with the balanced movement of the distributing mechanism, provides all that is required for the efficient action of an engine of this class.

As before pointed out, one of the most important factors in the successful working of an hydraulic engine, or, indeed, of any pressure pump, is a properly-proportioned air chamber kept correctly charged. To obtain this result

automatically, the hydraulic air pump illustrated at Fig. 178 has been designed. This simple device, known as the Wipperman air charger for pump balance chambers, consists merely of a chamber H acting as an hydraulic pump, for which purpose it is placed in communication with one end of the pump or engine cylinder, the stroke of the water piston in H being regulated by the valve K. In the cover A is a small air inlet valve and a delivery valve, by means of which and the supply pipe S the air chamber R can be charged to any predetermined pressure, water gauges W and W¹, as well as a pressure gauge G, being provided. In the illustration, a pump plunger is represented by P, inlet and outlet valves by V, and water delivery at D, this extremely useful apparatus requiring no further explanation.

The influence of a properly-arranged air spring or cushion on the efficiency and smoothness of action of any reciprocating water engine or pump is well known, and the absolute necessity for due regard to be paid to the correct charging of the air chamber when used in connection with long conduits will be recognised on a moment's reflection, considering the powerful effects that can be produced by the kinetic energy stored in an incompressible fluid such as water, when flowing through a pipe at only the velocity corresponding to a plunger speed of 180 feet per minute, seeing that at even this moderate velocity the momentum or *vis viva* of a column 100 feet long, and of an area of 50 inches —i.e., such as obtaining in a pipe 8 inches diameter, is capable of exerting a force equal to 300-foot-lbs. To this cause must be attributed the limitation of plunger speed to from 150 to 250 feet per minute, the thump and wump effect noticeable in large pumping engines due to water concussion and valve action, and probably many of the bursts that occur in our hydraulic and water-supply street mains.

Passing from a bad effect to a good effect, it is appropriate to add that the energy of a moving column of water when suddenly arrested can be utilised for raising a proportion of the water to a higher level than the source of supply in a particularly useful and simple construction of water engine known as the hydraulic-ram pump.

Hydraulic power may be used to step-up the pressure supply, and in this application (*vide* Fig. 179) requires an exactly oppositely proportioned power cylinder to pump barrel, as used in a mine unwatering pump, as shown in Fig. 176, in which application water is supplied at a higher pressure to the power cylinder than that due to pressure head to overcome friction and inertia. The direct-acting simplex pump illustrated by Fig. 179 represents an hydraulic relay or pressure-intensifying pump adapted for connecting up to a town pressure-service supply that is delivered at an insufficient head to force water to the height required; as, for instance, to tanks at high elevation such as used for fire-extinguishing and other purposes.

Referring to the sectional cut, it will be seen that the power cylinder of this simplex type of pump is fitted with pressure-thrown piston valves (*h*), which are stemmed direct on to the shuttle pistons (*p*), and actuated by pressure flow from the service supply at (*r*), the movement of the pump being controlled by a pair of tappet valves (*t*), one of which is opened near the termination of each stroke by the striker gear (*l d k*); the stem of each tappet is recessed at the valve end to form a passage for water to flow either towards or away from the shuttle pistons, as indicated at (*f*), this construction being adopted to afford a sharp action, but of course makes it necessary for the pump to be fixed over a tray suitably arranged to drain off the exhaust water.

In applying hydraulic power to actuate a relay pump for forcing water

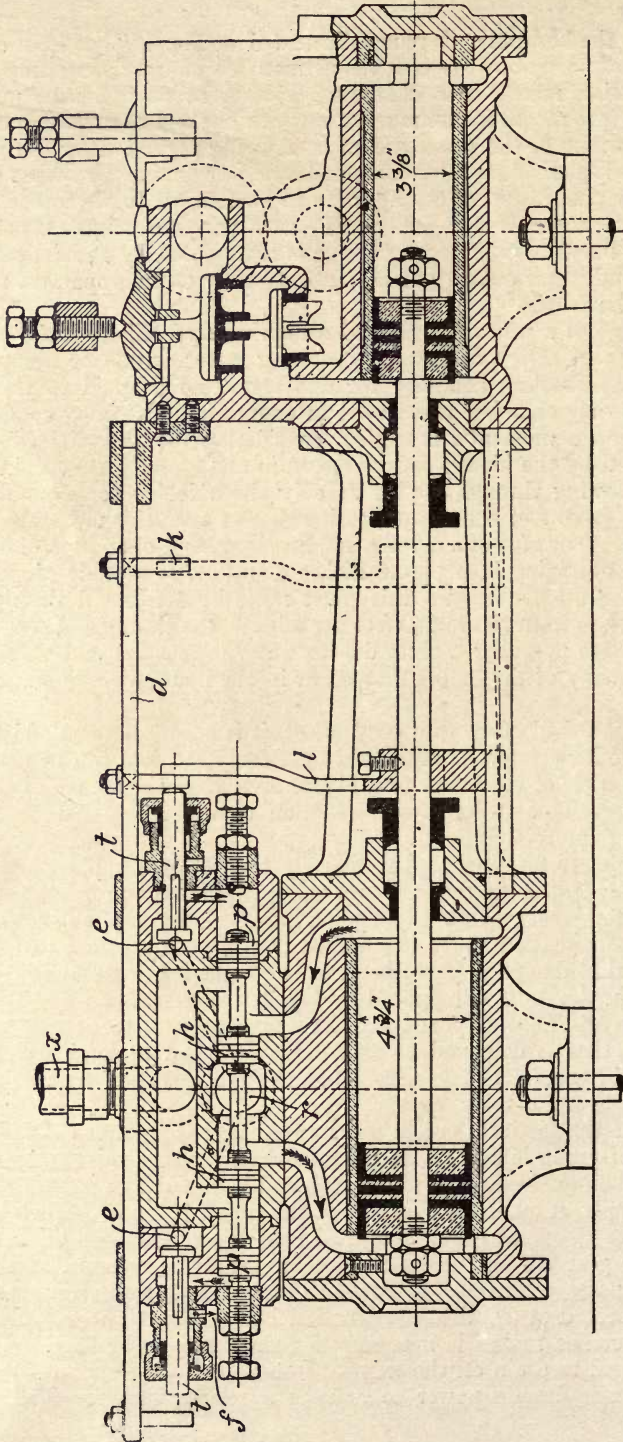

Fig. 179.—Hydraulic Relay Direct-acting Pump.

to a higher pressure head than that represented, for example, by the town supply, a comparatively short connection may be used between the power cylinder and the pressure main, so that the effect of *vis-viva* in the supply pipe be proportionately small.

Hydraulic Rams.

The energy of a moving column of water when suddenly arrested can be utilised for raising a portion of the water to a higher level than the source of supply in a particularly useful and simple construction of water engine and pump known as a hydraulic ram, in the working of which momentum effect, so undesirable in a plunger pump, can be utilised to good purpose; this plungerless water-raising apparatus consists essentially of a chamber forming a continuation of a pipe connection with a cistern at a higher level, which may be supplied with water from a spring, brook, or other source. In the ram chamber of this momentum pump is a trap, momentum or dash valve, that normally remains open, but is free to close as soon as the current set up by the escaping water has acquired a certain velocity, with the result that the moving water column flowing down the supply pipe known as the drive pipe is suddenly arrested, thereby converting the kinetic energy represented by the velocity multiplied by the length of the column into static pressure, and thus causes a portion of the water to be forced into an air chamber communicating with the rising main or delivery pipe. The complete apparatus constituting a hydraulic ram is thus seen to consist of a sloping pipe terminating in a chamber having a trap escape valve, and a pressure valve opening into an air chamber; there is no mechanism other than this required in a simple momentum pump constructed to raise a portion of the drive or power water. In action these pumps work with a period of from 40 to 200 pulses per minute, depending on the pressure flow in the drive pipe, and the length of stroke or beat of the escape valve.

The effect of water concussion in long lengths of pipe had evidently been known for a long time before a practical application of this principle was made by Whithurst for raising water; the first apparatus such as is now known as a hydraulic ram having been fitted with an ordinary bib escape cock, turned by hand, this being about the year 1770. Sixteen years or so later, Montgolfier improved on this by fixing a large ball-float valve working in a cage for the escape of the drive water, which automatically closed it when sufficient velocity had been attained in the outflow, and by this means was able to produce a ram water pump having most of the essential features such as remain to this day, as will be seen by the following illustrations. Since Montgolfier's time the hydraulic ram, which, as will be admitted, is by no means a modern invention *per se*, has been improved in detail and application by various inventors, including Leblanc, Lemichel, Hachette, Belier, Durozoi, and Sommeiler in France; and by Pearsall, Keith, Blake, and many others, in this country. The first application of this principle for dealing with comparatively large volumes of water was made by Sommeiler, who used as many as 20 ram pumps in connection with the drainage of the Mont Cenis Tunnel.

The principal drawback experienced in the working of ram pumps of large size at this time was due to excessive shock resulting, as might be supposed, from the violent closing of the momentum valve. Pearsall (1880-1890), in order to remove this defect, constructed several pumps on the ram principle, in which the trap, escape, or waste water valve was operated by an auxiliary air or water motor speeded to synchronise with the pulsation of the water column in the

drive pipe. By this means and other improvements, Pearsall was able to work his ram pumps with a higher duty than hitherto attained. As, however, this pump departs so widely from the automatic and simple action peculiar to pumps of this kind, and involves as much mechanism and cost as would be met with in a plunger pump worked by a separate engine, it has long since fallen into disuse.

The siphon ram, illustrated at Fig. 180, is another adaptation of the principle of employing a column of water set in motion by gravitation to act as a pump; in this instance, water at one level is caused to lift water from a lower level to a reservoir at an intermediate level. As an example, water flowing down the sloping drive pipe R impinges on the momentum valve V, which, being balanced by B, closes as soon as a certain velocity of flow has been attained in R. Meanwhile, the column of water set in motion in the pipe M, by reason

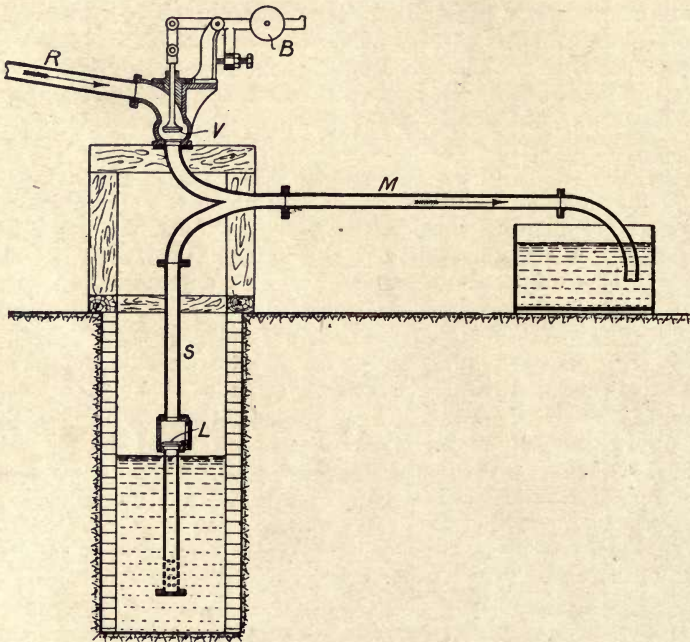

Fig. 180. Leblanc Siphon Ram.

of its momentum, acts as a pump to the suction pipe S, which may, for instance, be utilised to unwater an excavation, drain a swamp, or on a small scale be adapted to lift water from a well, thus supplementing the supply obtained from a higher level. In the reaction, the suction valve L is forced back, and the trap valve V raised off its seat, when the water from R will proceed to put once more into motion the column in M, the pulsation being timed by the beat adjustment of the momentum valve.

A typical example of hydraulic ram in its simple form—*i.e.*, when constructed to force a proportion of the drive water to a higher level, is illustrated by the sectional drawing, Fig. 181. In this design there is evinced one or two improvements in detail, such as the rubber double dish delivery valve B, and the arrangement of momentum valve D with propeller disc E and bored brass liner

F, by which means the annular space for the escape of the waste water is maintained uniformly all round, so as to result in a quick-closing action with but

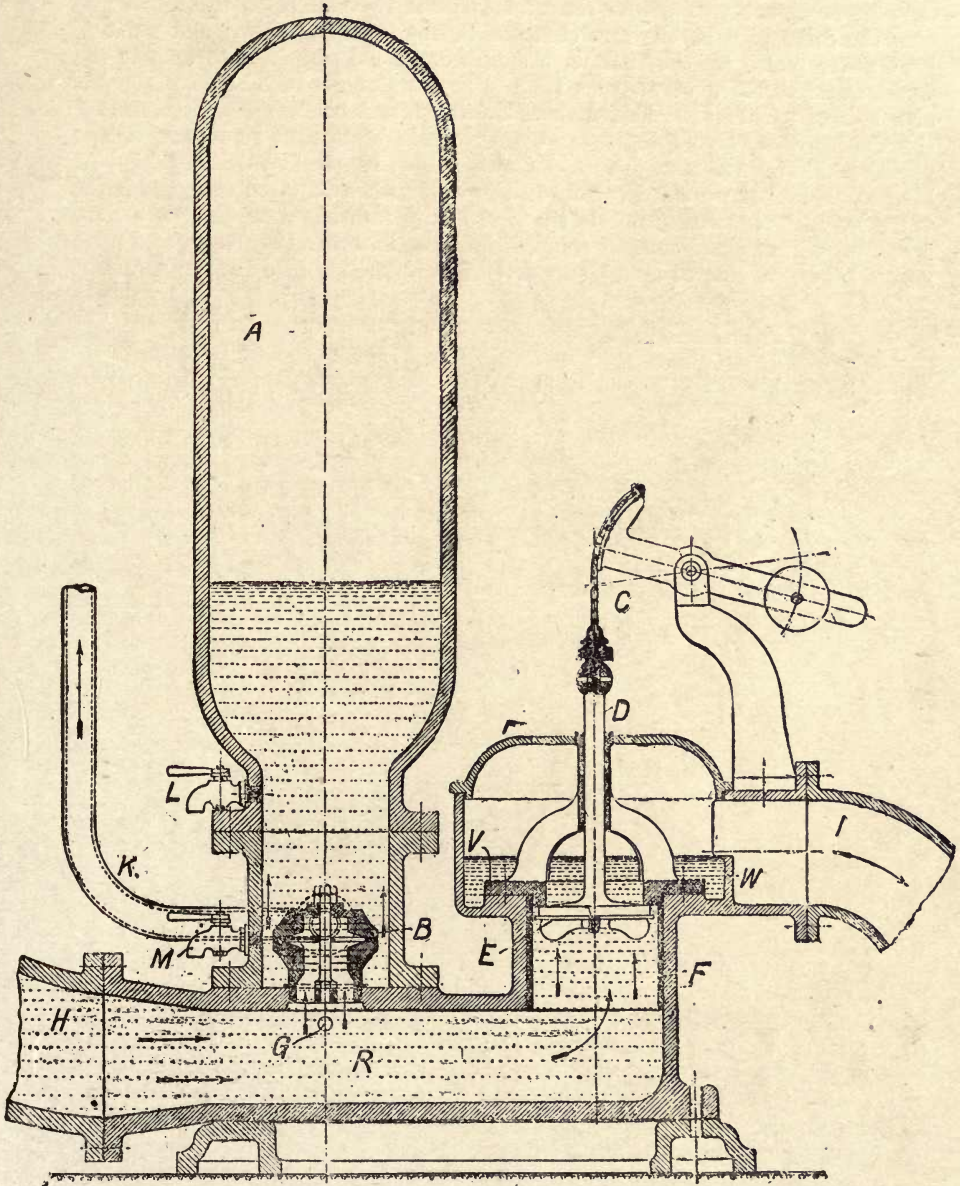

Fig. 181.—Keith's Hydraulic Ram.

low velocity of drive water, the diameter of the detachable disc E being determined by actual trial. The balancing gear C is only necessary when the velocity

of the power water is less than 5 or 6 feet per second, above which the propeller disc is capable of automatically closing an unbalanced metal valve.

In completing the description of the Keith & Blackman hydraulic ram, it will only be necessary to mention the various parts referred to in the drawing—viz., the drive pipe H, the ram chamber R, the brass valve seat and guide V kept water sealed by the well W, a splash cover F being used to confine the waste water to the overflow pipe I. The pressure or delivery valve B consists of a pair of rubber discs held in position above and below by brass retainers, this double dish valve being separated by a thin brass disc, as shown. Other parts completing the ram are the air vessel A with attached delivery pipe K, bibcocks L and M provided to run off the water when required to examine the valve B. An air-snifling nozzle situated in the ram chamber at G is a very necessary adjunct, and consists simply in this, as in most other cases, of a plain nozzle having a hole of about two or three millimetres in diameter, which is

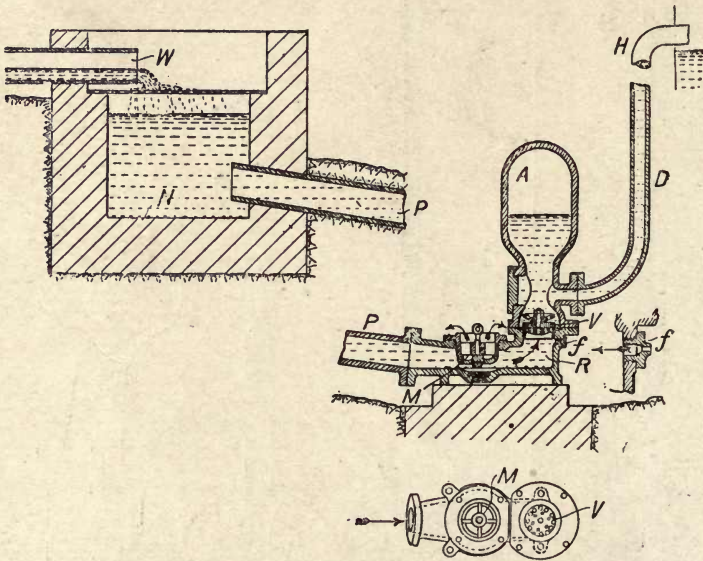

Fig. 182.—Arrangement of Drive Pipe on Glenfield Hydraulic Ram.

enlarged on the water side of the nozzle to a quarter of an inch or so. The action of the snifling aperture permits a slight indraught of air at each pulse reaction, and thus maintains the supply in the air chamber from falling short through absorption. In some of the earlier Durozoi and Sommeiler hydraulic rams a contrivance was used somewhat resembling the air-charging hydraulic pump shown at Fig. 178, but would obviously detract from the beautiful simplicity of the hydraulic ram, especially for the smaller sizes, these being often left quite unattended for months at a time.

A design of even greater simplicity is illustrated at Fig. 182, this also showing the general arrangement of drive pipe P and cistern N for the power water supplied at W. The length of the drive pipe should not be less than five times the height of the fall from the cistern N to the ram chamber R, and is often made as long as ten times. In order to obtain the necessary fall, the water may have

to run along a supply pipe, as at W, for a considerable length, and nearly level to a point where the ram may be situated, so as not only to ensure a good fall for the pipe P, but also to obtain sufficient difference of level for carrying away the waste water. In the Glenfield ram illustrated, the momentum valve M is situated at the bottom of a cup seating, so as to ensure a water seal; the bottom of the brass valve is fitted with a rubber buffer stop, and the same material used for the delivery valve V, the air-sniffing nozzle being shown at *f*. In this design, the valve V can be removed without difficulty through a side door, and the complete pump is probably one of the most simple of its kind.

In regard to efficiency, a properly-constructed hydraulic ram is capable of returning from 50 to 75 per cent., a result obtained from one of a pair of Blake rams used as a relay for forcing water supplied by the Blackburn Water Works, to an outlying suburb situated at too high an elevation for the town pressure, pumping with an efficiency of 78 per cent., according to a test made by the engineer to the Corporation; this ram was on this occasion supplied with 164,000 gallons per day, with a fall of 32 feet, and returned 47,000 gallons per day to a height of 84 feet, including pipe friction. The quantity of water generally available, however, for working a ram is more often limited to less than one-tenth of this amount, and the purpose for which such is chiefly used, is therefore the supply of country mansions and other isolated places requiring a small but reliable water supply; nevertheless, many thousands of these useful machines are in continuous operation up and down the country, and are now also being recognised as suitable for irrigation purposes in many places abroad.

In computing the efficiency of a hydraulic ram at 60 per cent., the delivery through D multiplied by the height H will be 60 per cent. of the quantity flowing down the pipe P multiplied by the height N; and in determining the diameters of the pipes P and D, the following equations can be used:—

$$P = \sqrt[5]{\frac{2 V^2 L}{F}} \text{ and } D = \sqrt[5]{\frac{4 v 2 l}{H}},$$

where V = volume of drive water per minute in cubic feet.

v = volume of delivered water per minute in cubic feet.

L = length of drive pipe in feet.

l = length of delivery pipe in feet.

F = fall of drive water in feet.

H = height of delivery in feet.

P = diameter in inches of the drive pipe.

D = diameter in inches of the delivery pipe.

In many cases impure water may be required to work a ram, such as where the available supply of spring water is only just equal to the demand; for this, the usual method is to interpose a diaphragm between the ram chamber and a second chamber fitted with inlet and outlet valves, this chamber, together with the diaphragm, constituting a pump. A hydraulic ram constructed in this manner is illustrated at Fig. 183, in which P is the connection for the drive pipe as usual, R the ram chamber, M the momentum valve balanced by the weight B and chain pulley Y; the escape valve in the Durozoi ram is hollow, and provided with openings at the side for the flow of water, the bottom edge forming a loosely fitting impeller piston in the seat T; a splash dome H is provided as in Fig. 181. Situated over the ram chamber R is a leather diaphragm F, the chamber immediately over it being provided with an inlet

valve E connected to the suction pipe S arranged to draw from the shallow cistern N. Over the displacer chamber is a delivery valve V opening into an

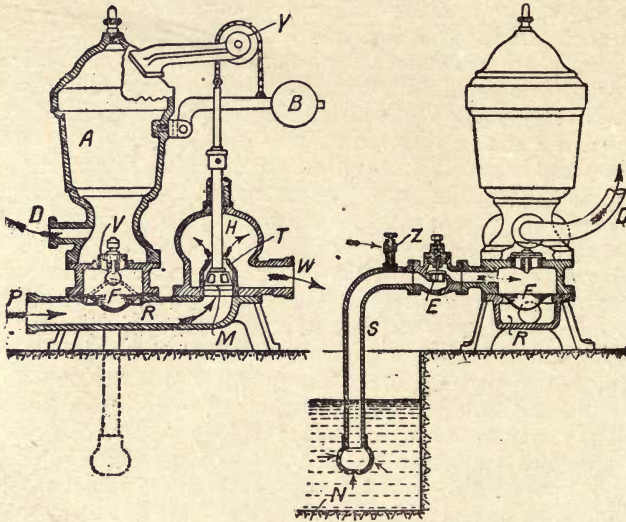

Fig. 183.—Belien-Durozoi Hydraulic Ram, with Diaphragm Pump.

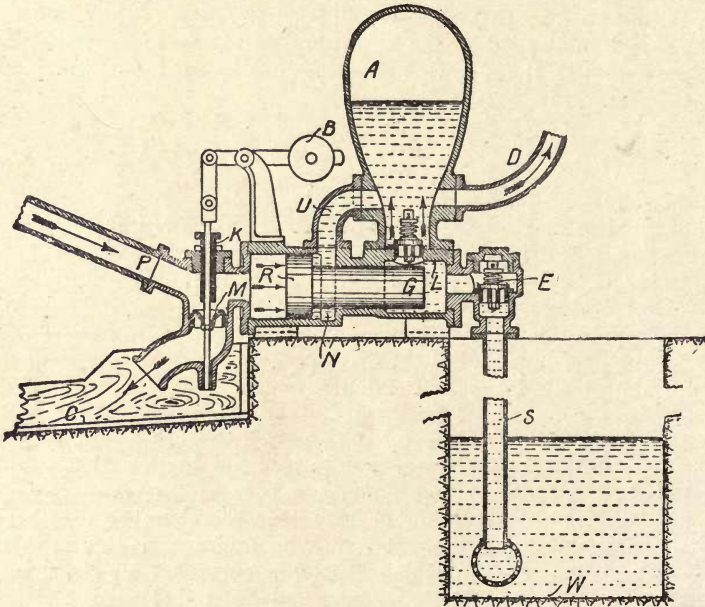

Fig. 184.—Hydraulic Ram in Combination with Plunger Force Pump.

air chamber A, to which the delivery pipe D is connected as usual; to this the necessary supply of air is maintained by the snifting nozzle Z, which is fitted

with a regulating screw. By an arrangement of this kind it will be impossible for the power water to mix with the spring water so long as the diaphragm remains intact.

For dealing with higher pressures in large volume, the hydraulically-actuated differential ram plunger pump, as illustrated by Fig. 184, is more suitable. In this pump the essential difference is in the use of the plunger R and ram G; the space between the front of R and the front end of the cylinder N is open to the bottom of the air chamber A, the difference in the areas of R and G being utilised to effect the return stroke by the pressure of water due to the height of D; the relative diameters of the plunger and ram will, therefore, be directly influenced by this pressure. The plunger G on its return stroke draws up water from W through S and E, this movement being effected by the pressure in A acting on the front end of R; normally the plunger will rest against the back cover, carrying the momentum valve M. The *modus operandi* of this pump is as follows:—On the column of water flowing down the drive pipe P being arrested by the closing of the trap valve M, the momentum of this moving mass will force forward the plunger R against the pressure in A, thus delivering a volume of water through D equal to the area of G multiplied into its stroke, the displacement in front of R being compensated by the air spring in A, to which a free communication is afforded by U. The stroke of the valve M is adjustable by turning the guide sleeve K, the valve being balanced as usual by the weighted lever B. Obviously a pump of this construction will not be able to return so high a duty as the simple form shown at Figs. 181 and 182, or perhaps as in Fig. 183, owing to the weight and friction of the plunger.

Other methods may suggest themselves for working a pump on the hydraulic ram principle. However, the method just described illustrates one practical means whereby water from one source, such as a spring, may be elevated in considerable quantities and to a great height by water flowing down a drive pipe, which may be arranged, for instance, to be fed from a river, in which case the procedure would be to tap the river preferably at the up stream end of a bend, and convey the water therefrom along a pipe laid as nearly level as possible to a cistern, from which to obtain the necessary fall to work the pump, the fall water flowing back to the river lower down the stream.

The selection of an hydraulic ram adapted to work a pump so as to be able to supply water from a source other than that used as power water, will be influenced more by its durability of action than by a high efficiency, seeing that economy in consumption of water when only used to work the ram is of secondary importance; and it must be borne in mind that the delivery pipe of a ram of this kind will require to be charged up before starting, in the one case to prevent rupture of the diaphragm displacer, and in the other to obtain the return stroke of the plunger. In comparing these two methods it must not be lost sight of that in the one, suction effect is limited to some 2 or 3 feet, whereas in the other a depth of 20 feet can be pumped from.

In a hydraulic ram of the kind illustrated by Figs. 180, 181, and 182, it may be said, in conclusion, that practically the only moving part requiring special attention is the momentum valve, this part having to be adjusted to suit the particular conditions under which water has to be pumped. There is, however, but little difficulty met with in the necessary adjustment for obtaining the required result; the avoidance of shock in pumps of large size is also found to be quite practicable by the use of rubber facings to metallic disc valves, and in some cases by rubber flaps without metallic packings, as used, for instance, in the Blake hydraulic rams or hydrams. From the point of view, then, of

simplicity, cheapness, and independence of action the hydraulic ram must admittedly be considered unequalled in its capacity for forcing water to a high level by the action of a stream having but a limited fall, the return being also greater than can be obtained by means of a water wheel and pump, or from any other hydraulically-actuated mechanism working on a small scale.

Steam and Air Displacement Pumps.

Force pumps in which liquid is acted upon in a direct manner by steam or air pressure are usually placed below the surface level of the water or other fluid to be raised, and consist of a chamber which may be provided with valves capable of automatically distributing the actuating fluid, as in the case of the several makes of steam pulsator pumps of the kind already described, and illustrated by Figs. 41 and 42, and known more generally under the name of pulsometers or expulsory pumps, which type of pump, however, although not falling exactly under this definition, are a very near relation to others that do—*e.g.*, the Erwin combined steam displacement and momentum pump and the Shone hydro-pneumatic ejector pump, which will be described later—the Körting float pump, illustrated by Fig. 188, may also be included as a self-contained displacement pump under this category, apparatus of this kind being equally well adapted for working under air pressure as with steam. Other pumps operated on the displacement principle by air pressure consist of chambers usually arranged in pairs, but without distributing mechanism, the displacement chambers being provided with inlet and outlet lift valves, a rising main, and an air pipe connecting the immersed pump with a distributor located either on the surface, as when used in connection with petroleum wells (*vide* Figs. 81 and 82); or at a point along an adit it is required to unwater when used for mine-draining purposes, it being essential for economy in the consumption of compressed air for the distributing mechanism to be as close as permissible to the displacement chambers in order to avoid unnecessary clearance.

The Erwin steam displacement pump—known as the “International”—is of a most unusual and interesting construction, as will be seen by the clearly-drawn sectional view, Fig. 185. This rather complex apparatus is made entirely in brass, and can be usefully applied for pumping clear water from a well or other source in situations where steam pressure can be conveniently obtained. The Erwin pump—sometimes called a ram—is generally placed beneath the surface of the water, and consists of an outer and inner tubular chamber, the central barrel being provided with a floating piston, and is placed in communication with the steam supply pipe at its upper end, and with the water supply at the lower end, where there is located a foot valve, just above which openings communicate with an outer annular chamber provided with an annular discharge valve. In action the barrel G automatically fills with water, and on steam being admitted at A, E, and F, the float piston R is pressed down to the position shown, thus expelling the contents of the barrel G to the chamber W by way of the openings H and thence past the discharge valve J. Immediately following the uncovering of the portways H, the steam exhausts to W and to the condensing chamber I above, the resulting vacuum lifting the foot valve N, by which action steam is cut off at F by the stem O, the valve N being forced by the inrushing water up to the edge of the barrel, when the water by its momentum caused by the *vacua* in G and W will, after filling the barrel G and condensing chamber W, open the valve J and flow up into the chamber I and discharge pipe L until balanced by the head resistance; thus it will be seen there is a steam expulsion

or displacement stroke followed by a stroke caused by atmospheric pressure. Openings communicate from W to the space over the valve N, and are for the purpose of allowing water to flow direct from the suction inlet to the condensing chamber W, to the barrel G, and up past the delivery valve J. The small aperture K is used to accelerate condensation in G by water injection as shown, and is controlled by J. At this stage the apparatus is completely filled with water, and the loose piston R will have ascended to the top of G, also by the reaction of the water flow assisted by steam pressure on the stem O the inlet valve N will close, this action again opening the ports F to the steam-supply pipe A, when the cycle will be repeated. Other parts used in this pump are the protecting sleeve B, the gauze strainer cone C, and a strainer inlet rose on the suction pipe; for obviously the free movement of the stem O, the piston R, and the annular valve J is essential in order to obtain

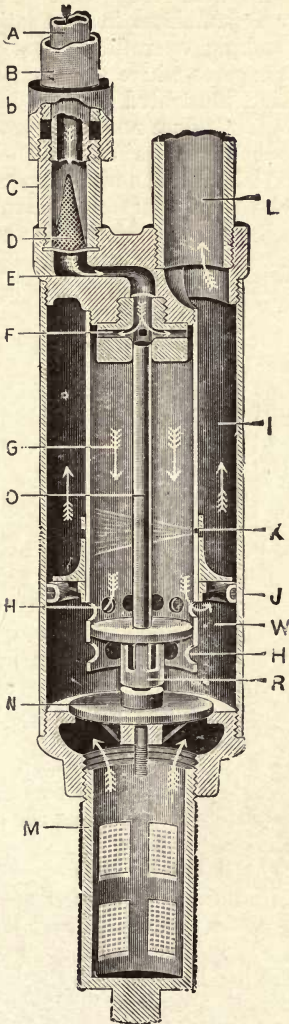

Fig. 185.—Erwin Steam Ram.

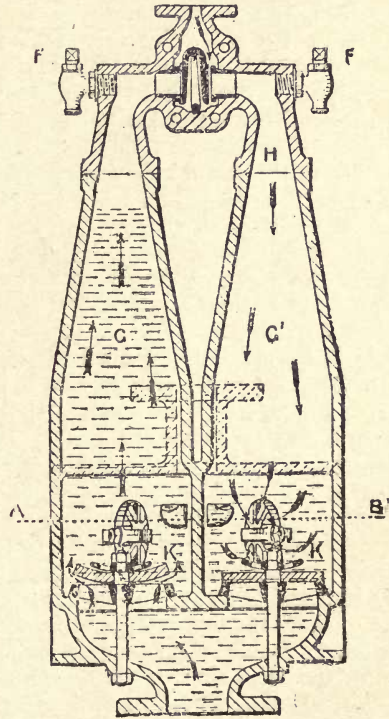

Fig. 186.—Brooke Expulsor Steam Pump.

the best results. The apparatus is exceedingly compact for its output, and can be easily lowered into position ready connected up to the steam and water pipes for immediate use without the aid of lifting tackle, seeing that the outside diameter of a pump capable of delivering 1,000 gallons per hour is only slightly over 3 inches and only 12 inches long, this size only requiring a $\frac{3}{8}$ -inch steam pipe

and $\frac{3}{4}$ -inch covering pipe to protect it from the water, and a discharge pipe $1\frac{1}{4}$ inches diameter; thus it is possible for a complete pump of this size to be lowered with ample clearance down a borehole well lined with a casing of an inside diameter of 4 inches. This novel contrivance can also be worked at some considerable distance from an available steam supply, and is not materially affected by condensation in the steam pipe, and presents probably the cheapest, lightest, and most compact form of pump of any yet considered.

For draining muddy water such as ordinarily accumulates in excavations, harbour works, quarries, foundation trenches, sinking operations, etc., and also for rescuing drowned-out plants and other purposes where an emergency pump is required, a displacement pump of the kind illustrated by Fig. 186 is very applicable. This pump, known as the "Expulsor," does not differ materially from the pulsator sinking pumps already described; the principle on which its working is based need not, therefore, be again explained. The most important part of all pulsator pumps of this character in which twin displacement chambers are used, is the automatic oscillating distributing valve placed in the throat to control the steam supply to the two necks communicating with the bottle or pear-shaped displacement chambers; in the "Expulsor" pump now being described, the double valve is saddle-shaped, and rides on a stirrup free to oscillate between the two valve seats; the valve itself is thus freely suspended, and can adapt itself to the form of the seat on either side.

It is well known that the efficiency of all pumps of this kind depends more on the sensitiveness of the valve action in its oscillation from side to side than on any other cause, as this movement is obtained entirely by the increased velocity of the steam inflow on the water being displaced to about the line A B, owing to the escape and increased rate of condensation of the steam resulting from the surface of the water being forced down below the openings leading to the discharge valves; at this stage the valve, in being swung over by the momentum effect of the steam inflow, and thus shutting off this side, results in producing a condensation, and causes this side to be again filled with water drawn through one of the suction valves K; in this manner one side is emptied while the other is being filled; it is, of course, necessary to prime the pump with water before starting-up for the first time after refixing. Small air-snifting valves F F are used to regulate the beat, a little air tending to insulate the steam from the surface of the water and to conduce thereby to economy. Condensation is further accelerated by the injection of a water jet as soon as a partial vacuum is formed on either side, two injection nozzle openings for which are shown on the line A B; this spray injection, in addition to hastening the condensation, causes the steam valve to oscillate with a sharper beat.

As before pointed out, this class of pump is not suited for lifts exceeding 100 feet, including suction and delivery, and does not work well with suction lifts of more than from 5 to 15 feet, according to the size of the pump; while the most suitable steam pressure is approximately 3 lbs. for every 4 feet of total lift for the small sizes, and 5 lbs. for each additional head of 8 feet in the larger pumps. It may be here mentioned that "Expulsor" pumps of this type are made in sizes capable of delivering from 1,200 to 40,000 gallons per hour, for which the size of the steam pipe varies from $\frac{1}{4}$ to $1\frac{1}{4}$ inches diameter, and the discharge pipe from 1 to 6 inches diameter, the height of the pumps increasing from 18 to 68 inches for the largest size, and the weight from 68 to 1,900 lbs.; the output capacity for each size is based on a "total" lift of 20 feet, and are not recommended for lifts greater than 90 feet, even for the larger sizes. It may be interesting to add that these pumps may be operated for "lifting" by

exhaust steam, and may be used for dealing with thick or corrosive fluids, which ordinary pumps are not suitable for, such, for instance, as are met with in chemical works of all kinds.

A most important application of the displacement principle is obtained with compressed air in connection with the pumping of sewage and other effluent matter from low-lying districts, towns, and buildings, to the necessary elevation, to ensure an unrestricted flow by gravitation to a common outfall; and constitutes a method also that enables a district to be effectually drained in sections from one central distributing compressed-air supply station. Pumping apparatus of this kind applied for drainage, the removal and consolidation of sludge and

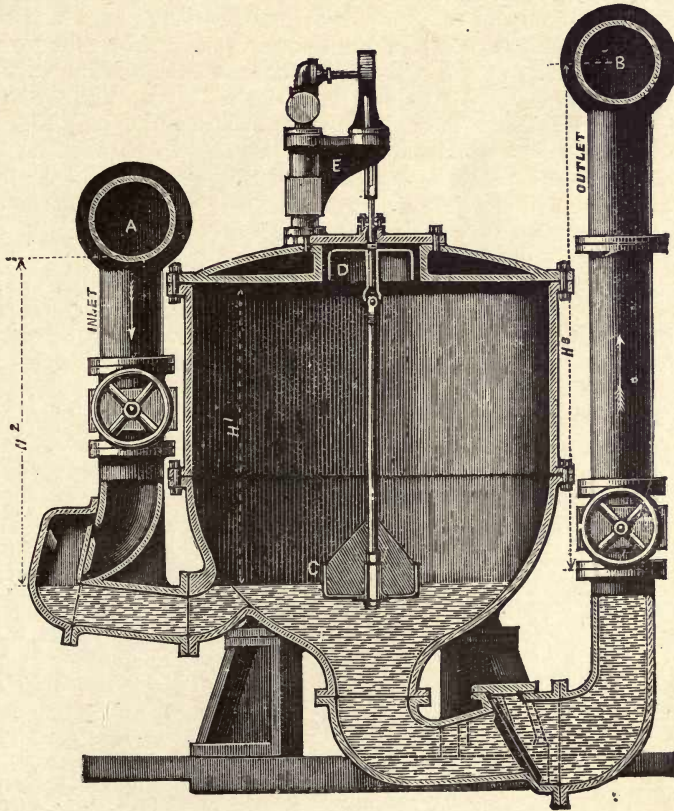

Fig. 187.—Shone's Pneumatic Ejector.

other like purposes, and known as the Shone hydro-pneumatic ejector, is shown by the section, Fig. 187. This air-pressure displacement pump consists of an inverted bell-shaped cast-iron tank, usually built up in two or three sections, and fitted with a cover jointed perfectly air-tight. The bottom of the tank terminates in an outlet provided with a flap rubber-seated valve, an inlet pipe from the collecting main, and terminates in a chamber containing a second flap valve connected at a point on the side of the tank quite low down; N.B., ejector tanks are always placed at a lower level than the collecting sewers. In action the effluent matter gravitates from the sewer pipes through the inlet

pipe A to the ejector tank, wherein it gradually rises until the tank is filled; an inverted air bell suspended on a rod passing through the tank cover is at this stage lifted—contact of the contents being prevented by the air entrapped within the bell float—and by this means opens the compressed-air supply valve at E; the air, being forced in at a suitable pressure from the distributing main, drives the contents of the tank out through the bell-mouthed opening at the bottom and through the outlet pipe B into the iron sewage rising main or high-level gravitating sewer, as the case may be, the fluid passing out of the ejector until the weight of the cup C—exposed and unsupported—is sufficient to pull down the bell and spindle, thereby reversing the air-admission valve, which first cuts off the supply of compressed air, quickly following which the outlet valve closes, thus retaining the liquid in the rising main; the action of the gear then places the interior of the tank into communication with an exhaust pipe, so permitting effluent matter to flow into the tank once more, and thereby driving the free air before it through the valve at E until the tank is again filled, when the bell float D will once again open the air-admission valve. The air-pressure displacement action is intermittent, the period being controlled by the rate of inflow, and is influenced by rainfall and other causes; the expulsion of the contents requires very little time, and the sudden rush of the discharge forms a most effective flush.

The employment of air-pressure displacement pumps of this kind ensures the provision for an effectual sanitary severance of the house drains of each district, or of separate buildings from the main sewer, thus constituting an effective safeguard against the conveyance of zymotic diseases through the drainage system from one district or building to others. Where several ejectors are installed in one pumping station, they are usually arranged to discharge in an alternate manner, for which purpose the air valves are under separate control; in thus working in rotation the demand on the air-compressing plant is more continuous and the resistance to the outflow rendered more constant.

Shone ejectors are made in sizes capable of displacing at each discharge from 50 to 1,000 gallons; the daily capacity of ejector plant supplied to various towns and buildings throughout the civilised world aggregates some 250 millions; for instance, six installations at Eastbourne are capable of dealing with 14 millions per day; ejector plant at Preston, 12 millions; Norwich, 6 millions; Gosport, 12½ millions; Hampton, 5 millions; Portsmouth, 3 millions; Rangoon, 22 millions; Bombay, 23 millions; Wellington, 6 millions; Kief, 7 millions; and Capetown, 2 millions. Besides which some 300 smaller installations, ranging from a capacity of 170,000 gallons per day, as at Winchester House, E.C.; and from 250,000, as at the Royal Courts of Justice; to 1¼ millions, as at the Houses of Parliament, Westminster, and so on; one of the several 50,000-70,000 gallon installations has been put down for draining one of the generating stations at the Marshall Field Powerhouse, Chicago, and many others for this and other purposes could be instanced.

In the working of displacement pumps for this purpose little expansion of the air is possible or attempted, although when suitably modified for pumping water some degree of expansion could be undoubtedly adopted with advantage in consumption of compressed air, seeing that in displacement pumps expansion can be obtained without loss due to falling temperature.

A variation of this type not yet considered is the float-controlled displacement pump, a good example of which is represented by the sectional cut (Fig. 188), for which may be claimed such advantages as the following:—A noiseless action that is entirely independent of lubricant; ability to work with

hot or cold water, and with an automatic action, which latter feature is of peculiar importance in connection with steam heating or drying installations, bleach and dyeworks, distilleries, etc.; a description of this construction and *modus operandi* will be, therefore, interesting and useful. As will be recognised, it bears a certain resemblance to the Worcester engine described on p. 5, *ante*, in that its working depends on the direct pressure of steam or air on the surface of the water in an enclosed vessel, and in being fed by gravitation. The notable feature in the Körtzing pump is the application of the float control, as used in certain forms of steam traps. Referring to the illustration, the principal part is the cast-iron vessel (b), into which the liquid to be pumped flows by gravitation

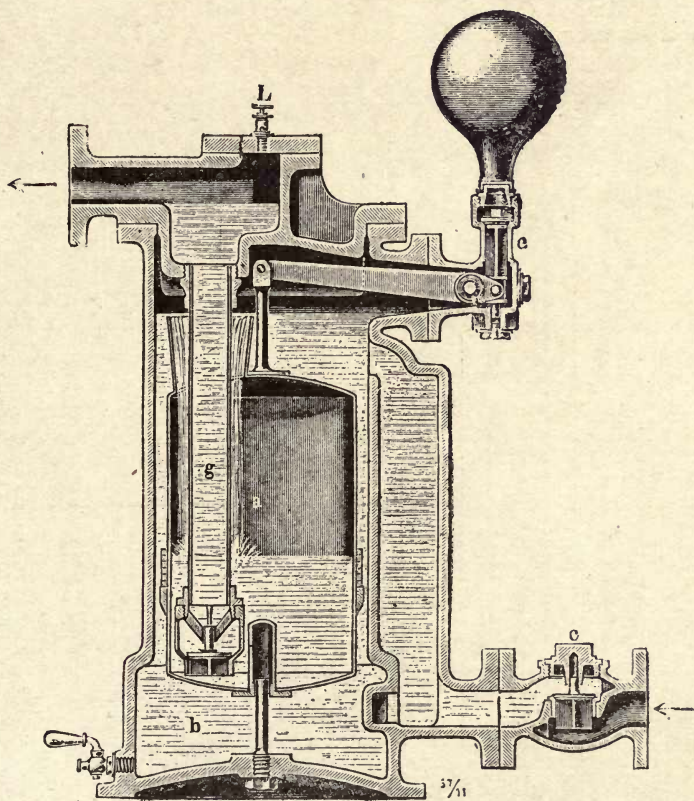

Fig. 188.—Körtzing's Float-action Feed Pump.

through the check valve C; this vessel (b) is normally maintained at the height of the weir dividing the inlet passage from the float cistern, thus the float (a) when emptied by the pressure of steam, will rise to the position shown, and remain there until weighed down by water overflowing to the neck around the outlet pipe (g). In sinking, the float opens a steam inlet valve at (e), and on the rising of the float following the expulsion of the water the steam supply is shut off, and immediately after an escape valve situated alongside the inlet valve at (e) is opened and allows the used-up steam to be exhausted into a condensing chamber. The cistern now being again at atmospheric pressure, water again

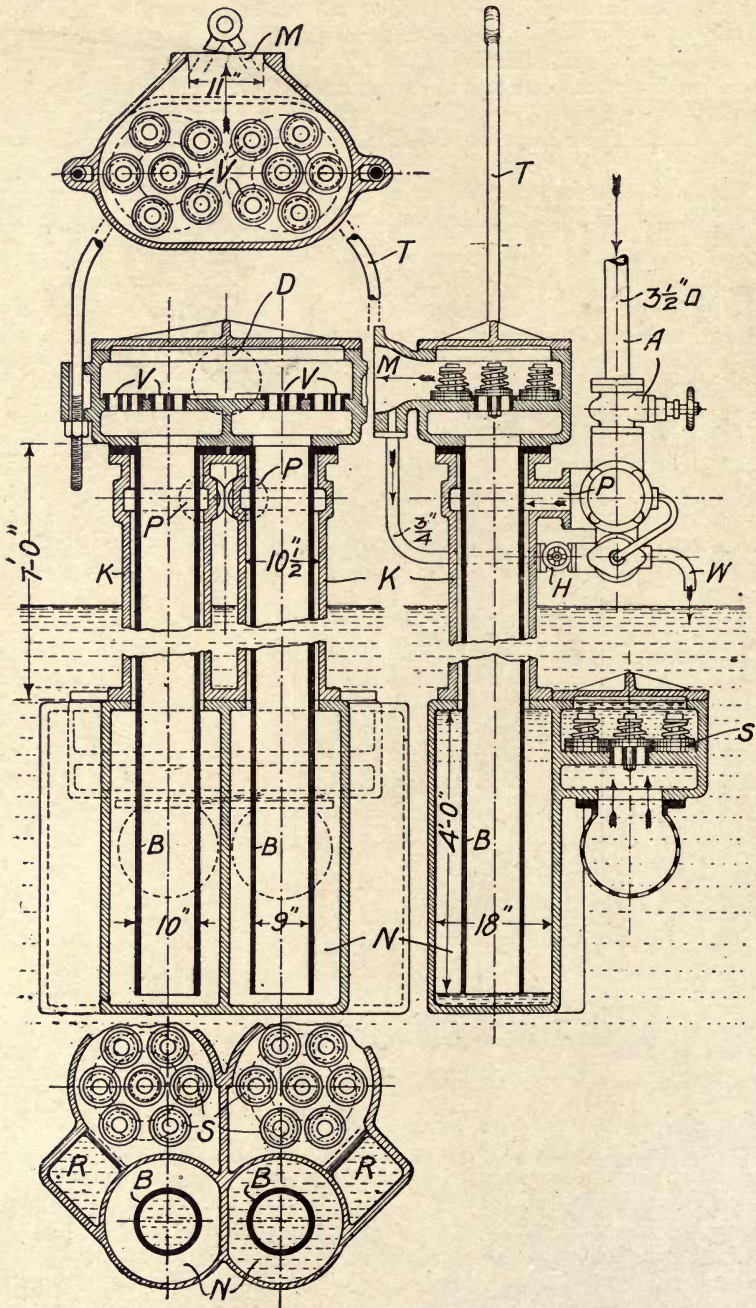

Fig. 189.—Twin Air-displacement Pump. Capacity, 30,000 Gallons per Hour.

enters at (c), overflows into and sinks the float, and is expelled through the valve at the bottom of (g), this operation repeating itself so long as the pump is supplied with steam and water. In the adjustment of the opening of the steam inlet and release valves, care must be taken to prevent the two valves being partially open simultaneously, in order to prevent the possibility of steam or compressed air blowing through to waste.

Pumps constructed to work on the air-displacement principle can be more advantageously employed for supplying water from an open well, lake, or other source in situations where it is not convenient to locate pumping machinery at the source of supply—a practice distinctly American—and can be usefully worked in connection with mine-drainage operations, where unwatering is required at a point distant from the mine shaft, such being adapted for clearing water from adits and like locations, for which purpose pumps actuated by hydraulic, compressed air, or electric power are adopted. Pumps of this kind are usually constructed with a double displacement chamber, and provided with two sets of inlet and outlet valves; in use the filling chambers are immersed, and can conveniently be suspended over their work like a pulsometer. The compressed air is supplied first to an automatic distributor, which may be actuated by air pressure, as in the Murray pump, or by water pressure derived from the rising main, it being advisable in either case to locate the distributor as close as possible to the displacement chambers, in order to keep down the waste caused by clearance.

Referring to the illustration (Fig. 189), which represents a twin air-displacement pump capable of dealing with 30,000 gallons per hour, N is a casting divided into two chambers, each communicating with a neck K, within which are suspended pipes B extending to within 1 inch or so of the bottom. The two necks K are surmounted by a headpiece D, containing two sets of delivery valves V, communicating with a common water outlet M; the double chambers N are also each provided with inlet valves S and downtake portways R, and are either immersed at a sufficient depth to force the water into the chambers at the required velocity, or may be situated at a point away from the water to be pumped, but at a lower level. In the example the pump is shown suspended by a shackle T directly in the water, and can be lowered from time to time, as may be occasioned by differences of level.

In action the displacement pump is operated by compressed air supplied at A to a distributor, whence pressure is caused to enter an inlet P to one displacement chamber, while the other is exhausting during the process of filling with water. The distributor is operated by water pressure obtained from the rising main connection M, the action of the distributor being controlled to synchronise with the working of the pump by the valve H, the water exhausting at W. The construction and working of the pressure distributor may be better explained by reference to Fig. 190, where compressed air is shown to enter at A and to be distributed through the ports A in the liner E to ports (p), and thence to P, communicating with the two displacement chambers respectively, the distribution being effected by the "to-and-fro" movement of the valve V in such manner that, while one side is open to A, the other is placed into communication with the exhaust ports (x) leading to the outlet X. The compressed-air distributing valve comprising the two pistons V is connected by the rod (t) to two hydraulic plungers B, which are actuated by water pressure along the ports (y) controlled by the shuttle (l l), working in the liner (r), the movement of the water-pressure distributing shuttle valve being controlled by two plungers (u u), placed in connection

with the plunger barrels B by the cross-over pipes (*k*) at (*i i*), which small inlets are placed so as to be uncovered only when the plungers B at either side shall have moved to the end of their out strokes, as shown at the right-hand side. At this point water pressure will communicate through (*i*) and (*k*) to the plunger (*u*) at the left end of the shuttle valve (*l l*), thus throwing it over into the position shown, the opposite end meanwhile exhausting through (*k*) and (*i*) into a groove (*g*), and thence to the outlet O at the left end of the main valve V, as shown. Water pressure controlled by a stop valve is supplied at H, and is caused to communicate through the ports (*d*) by one of the pistons (*l*) to (*y*), and thus to force over B to the end of the stroke to the right or left, the opposite end at this time being placed into communication with the exhaust ports (*w*) and to the outlet W.

The valves V are proportioned to cut off the air admission at one-third of

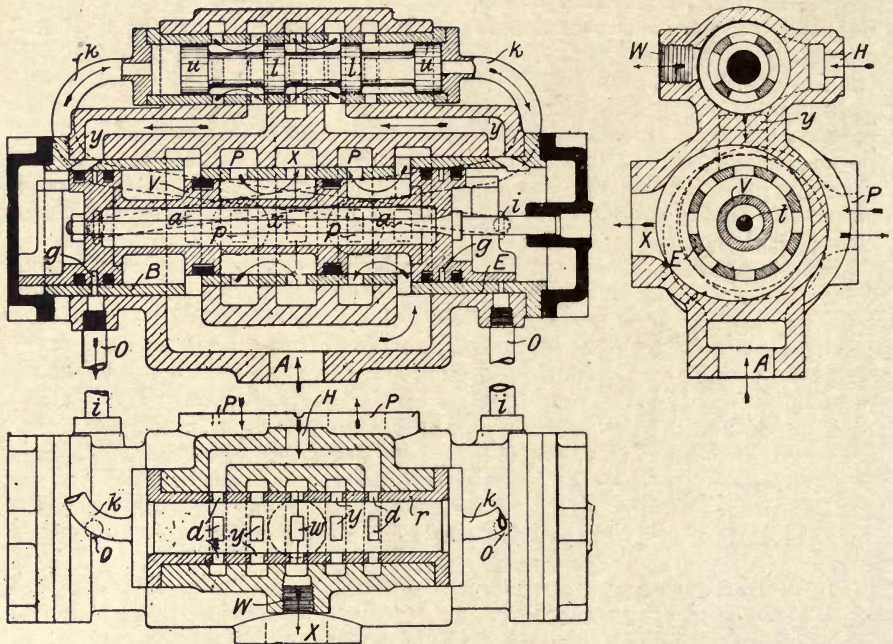

Fig. 190.—Hydraulic Distributor for Twin Air-displacement Pump (*Butler*).

the displacement stroke of the water pistons in B at either side, but can be proportioned to obtain an earlier cut-off when desired; the action of the distributor is absolutely certain and "even" throughout the stroke, and can be regulated to a nicety to suit the requirements of the pump. The advantage of an air-displacement pump over an air piston and plunger pump consists in the absence of mechanical friction, and in the absorption of heat from the water and displacement chambers during expansion; there is, moreover, a total absence of glands, and possibility of piston and plunger leakage. Under the best of circumstances power transmission by compressed air is not by any means an efficient one, recognising that ordinarily from 35 to 45 per cent. is lost in the most efficient compression process. There are purposes, however, for which the use of air power for pumping is more expedient than any other, notably in

mining operations, and any means conducing to economy in its application is the more important, owing to the losses incurred in compression.

In regard to consumption, a pump of the kind described and capable of forcing 500 gallons per minute against a head of 300 feet will work at from eight to nine double strokes per minute, each side delivering 30 gallons per displacement, and will use 2 cubic feet—including the clearance between the distributor and the water piston—at each stroke, at an initial pressure of 200 lbs. per square inch. Now, 34 cubic feet per minute at this pressure represents 80 air horse-power, and the water horse-power $45\frac{1}{2}$, the air supplied at this pressure and cut-off at $\cdot357$ of the stroke—including clearance—developing an average pressure of 156 lbs. per square inch; 1 cubic foot of air is thus required to raise $2\frac{1}{2}$ cubic feet of water, which shows that the ratio of air horse-power to water horse-power is as high as 1 to $\cdot57$, and certainly does not leave much margin for cooling in expansion, mechanical friction, and leakage as would occur in an air engine and plunger pump. However, a better result can be obtained with an earlier cut-off combined with a negligible clearance, there being no practical difficulty in locating the distributor right down to its work, where the action of the hydraulically-actuated distributing valve would not be detrimentally influenced by working under water. Under such conditions, air at the same initial pressure of 200 lbs., when cut-off at one-fourth the water stroke, would be capable of raising the same quantity of water to a height of 250 feet, and would develop an average pressure of 129 lbs. per square inch, the air used in this case representing 48 H.P., and the water raised 38 H.P., with a ratio of air horse-power to water horse-power equivalent to as 1 is to $\cdot79$, a still better result being possible with a cut-off at one-eighth. But an equal volume of water—viz., 500 gallons per minute—can be raised against a pressure head of 150 feet with a consumption of 11 cubic feet of air at 200 lbs. pressure per minute, when the average pressure would be 80 lbs., the air horse-power 26 \cdot 4, and the water horse-power 22 \cdot 7, with a corresponding ratio of air horse-power to water horse-power of 1 to $\cdot86$, the ratio of I.H.P. in the steam cylinder—with two-stage compression—to water horse-power would thus show an efficiency of 1 to $\cdot56$, a result that could not possibly be obtained with an air engine and pump without means for reheating the air and the employment of a flywheel. A direct air-pressure pump, working on the displacement principle, is therefore seen to be capable of raising water, oil, or other liquid more economically than an air-driven plunger pump, for the reasons already stated—viz., that (1) compressed air can expand nearer to the isothermal line in a direct-acting displacement pump than behind a piston, and (2) with less loss in leakage; also (3) without mechanical friction.

Gas Displacement Pumps.

The latest, and by far the most important development in direct-fluid pressure pumps is the gas displacement, or hydro-gas pumping engine, in which force is exerted from the combustion of an explosive mixture of gas and air to raise water by direct pressure. The problem of applying gas power in a more direct manner than can be obtained in a piston engine has engaged the attention of a number of inventors, some of the very earliest attempts to obtain power from explosive mixtures taking the form of a pistonless engine. An engine of this class was suggested by the writer, in the course of a discussion on the subject of gas turbines at the Institution of Mechanical Engineers, in 1904, and a sectional elevation of an actual design worked out on this principle before this time is illustrated by Fig. 191. This engine, which may be termed a hydro-gas turbine,

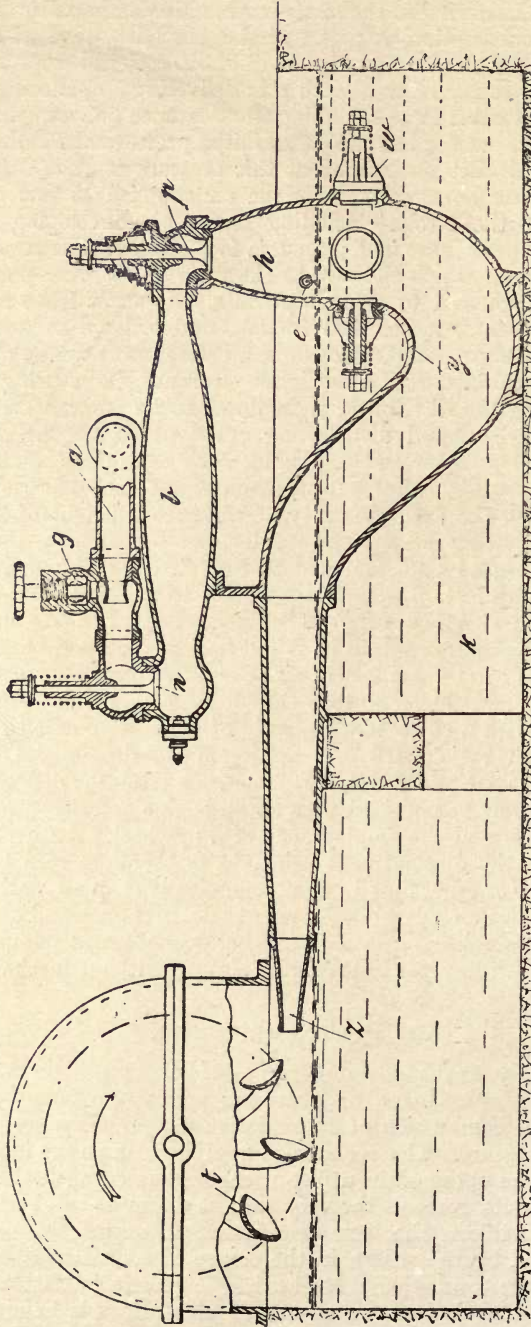

Fig. 191.—Sectional Elevation of Butler's Hydro-gas Engine, or Gas-displacement Pump.

causes an intermittent jet of water to be forced against the wheel of a turbine at high velocity. Referring to the sectional diagram, (y) is a submerged syphon-shaped explosion chamber, provided with a series of filling valves (w) arranged in a belt below the water level. Above the filling valves the chamber is continued upwards to form a combustion chamber, to which explosive mixture is supplied at a pressure of from 80 to 100 lbs. per square inch from a primary explosion chamber (b), past an intercepting valve (p); the effect of the primary explosion is to cause a secondary explosion effect, at greater pressure, to take place in the chamber (h), and by this means to expel water contained in the syphon chamber (y) in the form of a jet at (z), against a turbine wheel (t). Immediately following the expulsion of the water, the burnt gases resulting from the primary and secondary

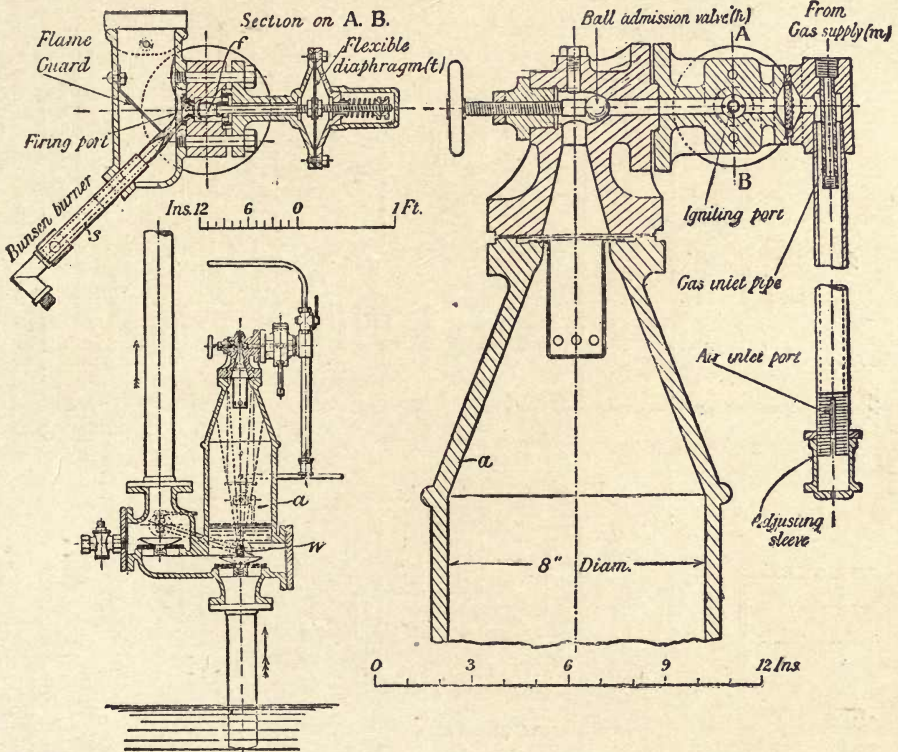

Fig. 192.—Joy's Domestic Gas Displacement Pump. Capacity, 1,000 gallons per hour against 20 feet head.

explosions will be free to escape. Succeeding charges of air and gas from (a) and (g) are automatically drawn into the primary explosion chamber (b), past an ordinary admission valve (n), by reason of the vacuum effect produced in the syphon chamber from the expulsion of its charge of water, and as soon as this takes place water is again free to enter the syphon through the filling valves (w) to the level of the contents of the tank or cistern (k), which is maintained at constant level by a float or overflow to make up for loss by leakage or evaporation. Ignition of the charge in the primary chamber is timed automatically by the water in the syphon chamber, on its contacting with the battery

circuit terminal (*e*), this taking place at the completion of the water instroke. The effect of the ignition at the end of an elongated chamber, as shown at (*b*), is to drive a portion of its contents, before combustion is complete, past an intercepting valve as at (*p*), into a secondary explosion chamber, as at (*h*); mixture can be, by this means, forced into the space over the water at a considerable pressure, depending on the force of the explosion in (*b*), and to the proportions of the two chambers. The mixture thus automatically compressed is ignited by the burning gases from (*b*) entering at the tail end of the charge transference from (*b*) to (*h*), and as commonly obtained in the starting of heavy gas and oil engines on this principle, frequently attains to pressures of from

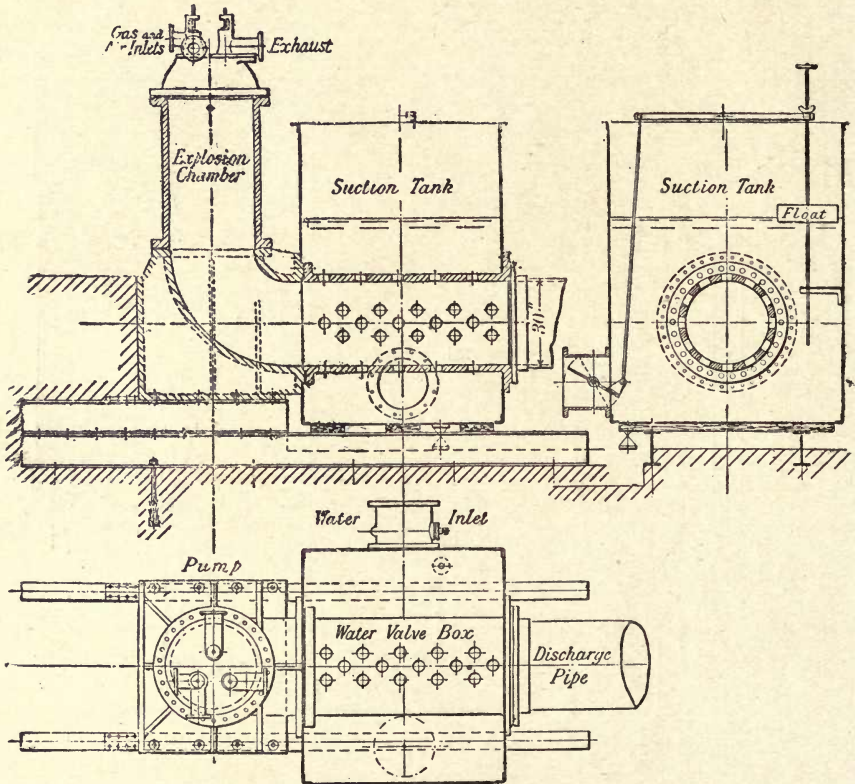

Fig. 193.—Humphry 4-stroke Cycle Gas-displacement Pump. Capacity, 250,000 gallons per hour against 35 feet head.

250 to 350 lbs. per square inch. The action of the issuing jet is obviously intermittent, the number of strokes per minute being determined in an engine of a given size by the area of the nozzle and supply valves. In regard to power, it is estimated that an engine built on these lines, and having a syphon chamber 15 inches diameter, would be capable of developing some 100 to 120 I.H.P., working with 15 to 18 water strokes per minute, on town-gas or petrol, but has one weak point—viz., the intercepting valve (*p*) between the low-pressure or primary combustion chamber (*b*) and high-pressure or secondary chamber

(*h*), which would be subject to considerable wear, owing to the violence of the closing action produced by the explosion of the compressed charge.

The gas pump illustrated by Fig. 192, and patented in 1908 by Bertram Joy, was described on the occasion of a discussion on the Humphrey gas pump (described below) at the Institution of Mechanical Engineers by Prof. Hele-Shaw, who had previously carried out a test on a small pump of this construction capable of raising 1,000 gallons per hour 20 feet, including a suction lift of 2 feet, when working at a speed of 24 pulsations per minute. In this pump the vacuum required for the introduction of a fresh charge of explosive mixture and water into the chamber (*a*) is produced by the combined effect due to the momentum of the water in the delivery column and the cooling action of a water spray, admitted at (*w*). After an explosion, which displaces by direct pressure the water in (*a*) by forcing it through the discharge valve, a vacuum is produced, which draws in a fresh charge of gas from the pipe (*m*) and of air from the pipe shown through a valve (*h*). As soon as the pressure in (*a*) becomes atmospheric, a spring controlled diaphragm (*t*) opens a firing port connecting the passage (*f*) to the flame flue and burner (*s*), and an explosion takes place. There is consequently no compression, and, therefore, a high economy in gas consumption cannot be expected, which, however, is not of the first importance in a domestic pump capable of being easily and quickly set in motion.

An improvement of far-reaching importance in the development of the gas-displacement pump was made by H. A. Humphrey at about this time (1906), who utilised the recoil of the water column to compress the charge of explosive mixture before ignition, thus enabling gas of low calorific value, such as producer and blast furnace gas, to be used. In the Humphrey gas pump, the explosion chamber (*vide* Fig. 193) is arranged vertically over a vertical or horizontal water chamber, provided with a number of inlet valves, and situated in a tank, the suction valve chamber terminating in a long discharge pipe opening either direct into an overhead tank, or into a closed tank containing air under pressure. The combustion chamber (*vide* Fig. 194) is provided with an inlet valve, an exhaust valve, and a scavenging valve, the last mentioned being situated at a lower level than the others; above this valve is situated the cushion chamber, which also forms part of the explosion chamber, in which the charge is compressed before ignition. The valve stems each carry top and bottom circular nuts (*a*, *b*, *c*, *d*), the latter two serving to limit the opening of the valve by coming in contact with rubber buffers, and the upper two nuts to lock the valves in their closed position, when the bolt (*e*) slides between the under side of the nut and the top of the brackets. In action: starting with all valves shut, ignition occurs on switching over the spark lever, which is followed by explosion and expansion of the charge (the locking bolts (*e*) at this time being in such a position that the admission valve is locked, and the exhaust and scavenging valves are free to open), which, after continuing to atmospheric pressure, causes the exhaust valve and the scavenging valve to open simultaneously by suction effect. In the exhaust pipe there is a light non-return valve (placed so that it is normally closed), which prevents the suction effect produced by the moving water column from drawing back exhaust products, and causes a rush of air through the scavenging valve into the explosion chamber, in such manner that the gases from the previous explosion are completely swept out. The suction stroke is comparatively short, and the water column beginning to return causes the scavenging valve to shut under the action of its spring; but the exhaust valve remains open while the products of combustion are discharged, and, on the water column reaching the exhaust valve, it is shut by impact, which action is

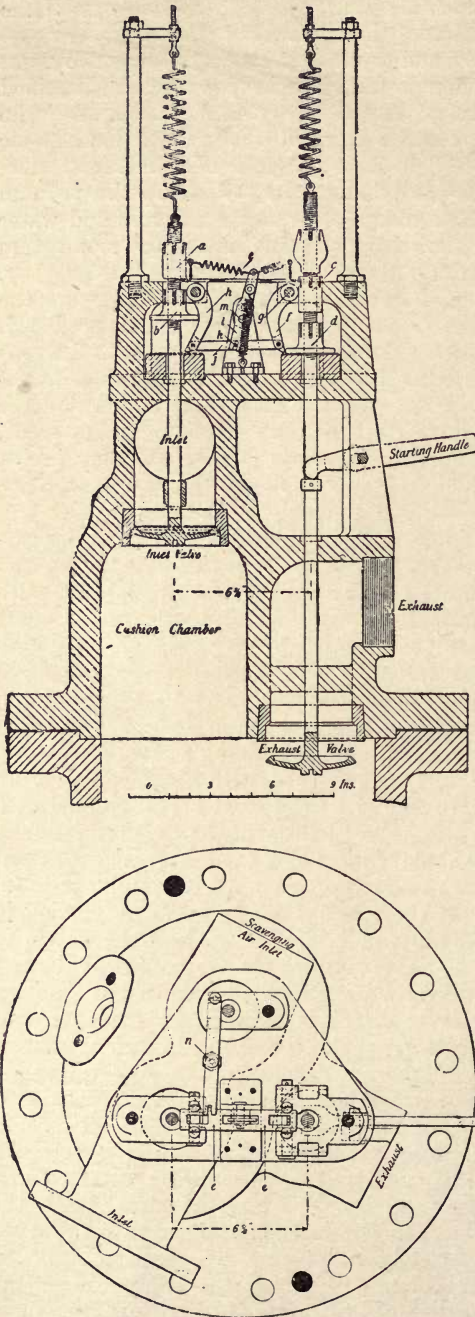

followed by the compression of the air cushion remaining in the top of the chamber. The expansion of this air produces the suction stroke and the intake of a fresh combustible charge.

It will, however, be seen that when the exhaust valve shuts the enlarged portion of its lower nut (*d*), bearing against the curved lever (*f*), hinged at (*g*), forces this lever to the left. Now, as there is another curved lever (*h*), hinged to the first lever by means of the link (*j*), this other lever has also to partake of the motion and move to the left, thus setting it in a position to be acted upon by the lower nut on the inlet valve. The link (*j*) carries a pin (*k*), which engages a lever (*l*), hinged at (*m*) in such a manner that when link (*j*) moves to the left the top of lever (*l*) moves to the right. There are two springs on lever (*l*), the one to the left being stretched, and that to the right closed, and, as these two springs act upon the bolt (*e*) in the position shown, the effect is to urge the bolt to the right. This bolt, however, cannot move until the top nut (*c*) has risen to its full height, which occurs when the exhaust valve shuts; the movement of the bolt then takes place, and locks the exhaust valve shut, and simultaneously releases the admission valve. Consequently, when the cushion stroke is followed by the charging outstroke, the suction opens the admission valve, and a fresh charge is drawn in. The opening and shutting of the admission valve reverses the action of

Fig. 194.—Details of Valves and Controlling Mechanism for Humphrey Gas Pump.

the gear, locks the admission, and unlocks the exhaust ready for the next cycle. In regard to the length of the tail pipe between the combustion chamber and the high-level tank, this must be sufficient to contain such a mass of water that its kinetic energy at maximum velocity shall ensure the burnt gases being expanded to atmosphere, which is the limiting condition, but the pump will work with a greater mass of water than necessary. For instance, a pump having an explosion and water inlet chamber 24 inches diameter (according to calculations) will deliver the following volumes against a constant pressure head with different lengths of tail pipe and velocities of discharge :—

Length of pipe in feet,	. 25	50	100	200
Cycles per minute,	. 61	31	14	7
Discharge, cub. ft. per min.,	527	486	447	417
Efficiency : $\frac{\text{P.H.P.}}{\text{I.H.P.}}$. . 0.98	0.95	0.91	0.82

The 25-foot pipe is, however, too short and the 200-foot pipe too long to give the best results.

In starting the pump a charge of compressed air is first admitted to the combustion chamber so as to depress the water level, when the exhaust valve is forcibly opened, thus allowing the water to rise until it closes the valve, and cause the cushion and charging strokes to take place when by the ignition of the charge the first discharge stroke takes place, the pump then continuing to work in the 4-cycle sequence—*i.e.*, to force the water column during the discharge or working stroke at such a velocity that it by its momentum partly overflows from the top of the delivery pipe; (2) the water column returns, ascends into the combustion chamber, closes the exhaust valve, and is brought to rest by an air cushion; (3) the column moves forward again (pendulum fashion) partly by the expansion of the entrapped air, and draws in its charge of explosive mixture; when (4) on the return stroke of the water column the charge is compressed and ignited, thus causing the water column to again perform a discharge stroke, and so on. It is necessary to add that water is drawn into the pump from the supply tank during the discharge stroke, the suction commencing from the time the column passes the inlet valves until it is brought to rest by gravitation. By varying the level of the water surrounding the inlet valves in this tank, the pump can be regulated in capacity by causing it to work with a longer or shorter charging stroke; the lower the suction water level the greater is the charge volume and output of the pump. In economy of fuel consumption, the gas displacement pump, under certain limiting conditions, has the advantage over any form of plunger pump, whether it be gas, oil, or steam driven, as the results contained in Prof. Unwin's report amply certify (see Table, p. 264).

The operation of the Humphrey gas pump is not confined to the four-cycle movement, as shown in Figs. 193 and 194, in which there are two oscillations each way of the water column for one delivery stroke, but can be made to force water either into an elevated tank, or against a pressure of air, at each alternate stroke of the water column in a pump having two explosion barrels A B (*vide* sectional diagram, Fig. 194*a*), the operation in a pump, according to this construction, being as follows :—Assuming that a compressed combustible charge has been supplied to one of the barrels A, and that the other is nearly full of water; explosion and expansion of the charge in A will cause an outward propulsion of the water column, and when atmospheric pressure is reached the exhaust valve of A will open, and water then entering from the tank will follow

	Lift 32·87 feet (mean of six tests).	Lift 25·95 feet (mean of three tests).	Lift 20·73 feet (mean of three tests).
Head over orifice, feet	3·89	3·63	4·52
Gallons pumped per minute,	1,621	1,567	1,749
Actual H.P. in water lifted or P.H.P.,	16·15	12·32	10·99
Cycles per minute,	13·8	11·8	11·4
Gallons pumped per cycle,	117	133	153
Average compression pressure previous to explosion, lbs. per sq. in.	44·7	33·2	19·8
Absolute pressure of gas in inches of mercury,	29·65	29·66	29·66
Volume of gas used per minute at 760 mm. and 0° C., cubic feet	22·368	18·663	17·143
Gas used per hour per P.H.P., cubic feet	83·12	90·93	93·61
Calorific value of gas in B.Th.U. per cubic foot,	147·29	143·45	145·26
Heat expended per P.H.P. hour in B.Th.U.,	12,243	13,037	13,596
Lb. of anthracite in producer per P.H.P. hour,	1·063	1·132	1·180

And more recent experiments on larger pumps have shown a thermal efficiency of 23·1 per cent.—*i.e.*, equivalent to a consumption of 0·95 lb. of anthracite per water horse-power-hour.

the column in D, and at the same time rise in A, and thereby expel the burnt products from the previous explosion; simultaneously with this movement

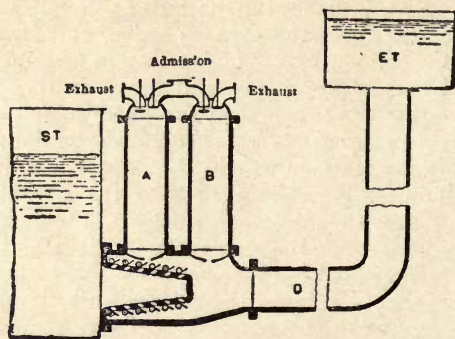

Fig. 194a.—Sectional Diagram of Two-cycle Humphrey Gas Pump.

of the water column D, the level in B will fall, and in so doing draw in a fresh charge of combustible. It will be understood that all this takes place during the outward movement of the water column in D, when by the return movement of the column, water rises in A, and thereby displaces the remaining exhaust products, and then compresses the charge previously drawn into B; after which, ignition of this charge starts a fresh cycle with the functions of A and B reversed.

Mr. Humphrey has also devised means for adapting his pump (whether of the single- or double-barrel type) to work with a suction lift, and also as a high-lift pump. Very little modification is necessary to adapt the pump to work with a suction-lift, and any Humphrey pump may be converted for forcing

against a high-pressure head by combining with it two air chambers E F, together with a series of non-return valves W (Fig. 194b). The smaller air chamber E is fitted with a downwardly projecting pipe K, open to the atmosphere at the top, and carrying a valve L at its lower end. The pump in action starts working by an explosion in one or other of the barrels A B, all valves excepting L being shut, and the water level as shown; when by the forward movement of the water column in D, the water will at first quickly rise in E until the valve L is shut by impact; the water will then (by momentum effect) continue its onward movement, first by compressing the air above the valve at the bottom of the vent pipe K, and afterwards by delivering a portion of the column set in motion past the pressure valves W until the kinetic energy of the column is spent. The pressure valves W then close, and the compressed air in E sets up a return flow, which displaces the products of combustion in one barrel, and compresses a fresh charge in the other barrel, thus starting another cycle.

Arrangements are being made for an experiment on a large scale to be carried out, in which a high-lift Humphrey pump will be used to drive a water turbine coupled to an electric generator, it being anticipated that the high economy of the pump will more than compensate for the loss due to conversion of water power into mechanical energy without taking into account its more continuous

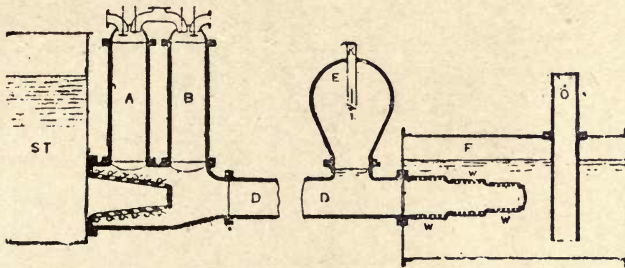

Fig. 194b.—Sectional Diagram of Double-barrel Humphrey Gas Pump adapted for high lifts.

action. But the Humphrey pumps recently installed at the Chingford Reservoir for the Metropolitan Water are of more particular interest, these being capable of delivering a total of 180 millions of gallons of water a day, which is equal to approximately two-thirds of the daily supply of London. This Humphrey gas power plant consists of five pumps, four each of 40 millions' capacity, and one of 20 millions of gallons per day. As an instance of their size, it may be stated that the diameter of the combustion chambers, valve-boxes, and bends connecting them with the horizontal water column play pipes is 7 feet, and the weight of some of the castings as much as 22 tons. The horizontal pipes are 6 feet diameter for the 40 million-gallon pump, and terminate at the delivery end in vertical towers of inverted cone form with a diameter of 15 feet at the top, which is a few feet above the highest water level in the reservoir. The capacity of a single unit is such that on each explosion as much as 10 tons of water are drawn from the River Lea and delivered into the reservoir against a head of 30 feet.

The pumps, which are supplied with gas produced from anthracite (the guaranteed consumption of which is 1.1 lbs. per water H.P.-hour), are located in five suction chambers, 32 feet long and 18 feet wide, into which the water

flows from a sump, 134 feet long by 12 feet wide and 12 feet high, the supply from the sump to the suction chambers being regulated by an automatic float-valve to maintain in each the desired level.

Apart from the novelty of the direct-action gas pumps used in this installation, an interesting feature arises from the fact that the total cost of the plant, consisting, besides the five pumps, four Dowson producers, cleaners, holders, etc., and all buildings complete, was £19,000 less than the total cost of a steam-driven installation based on the lowest tender for quick-revolution steam engines coupled to centrifugal pumps, and including boilers, chimney, and buildings.

CHAPTER XV.

FIRE PUMPS AND HIGH-SPEED PLUNGER PUMPS.

THE factor more than any other which may be held accountable for the high plunger speeds now being used in force pumps for an increasing number of purposes is undoubtedly the fire pump, an engine in which mobility and quickness of action has been evolved to a high degree of perfection. In considering,

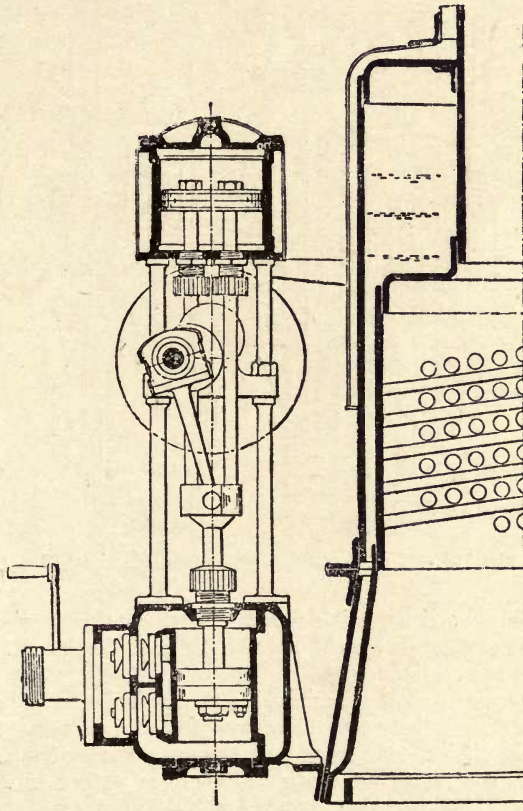

Fig. 195.—Sectional Elevation of Shand-Mason Fire Engine and Boiler

therefore, the several types of high-speed pumps, their characteristics for and against, the fire pump in its various forms may consistently be taken first, recognising that the London Fire Brigade alone possess over 100 fire engines and floats. Of these, the majority, which were portable road steamers, until

recently, have been superseded with advantage by petrol, the automobile principle being peculiarly adapted for such purposes as these, where speed and readiness are so much in demand.

The development of the portable steam fire engine will not be without interest, as many changes have been introduced from time to time in the general arrangement of the boiler, pump, and carriage; the practice prevailing with the two principal makers of this speciality being to use a modified form of vertical boiler fitted with either cross tubes alone, or with cross and vertical tubes combined, the upper part of the shell surrounding the tubed portion being bolted to the lower part surrounding the firebox by two angle-faced joints, so rendering access to the interior for cleaning and repairs. The engines, usually of the flywheel direct-connected double-acting plunger type, are situated for the most part vertically either in front or behind the boiler, some brigades preferring one construction and some another, whilst others specify for the engines to be

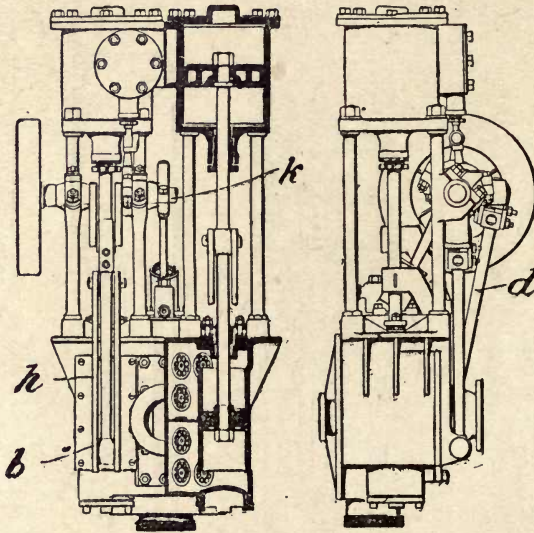

Fig. 196.—Merryweather Fire Pump (Flywheel Type).

arranged horizontally, either with a single engine at each side of the boiler, or with a double engine, in which case the boiler is displaced somewhat out of the centre line of the carriage.

In the construction of the engines, many methods have been adopted for connecting up the rods (between the steam pistons and water plungers) to the crank shaft; for choice, this may be either the sliding block crosshead, the frame crosshead, the frame connecting-rod, or, as shown in Fig. 195, with a connecting-rod working from a crosshead joining up the plunger-rod with two piston-rods, arranged one at either side of the crank shaft, which, it will be noted, is a modification of the construction shown by Figs. 14 to 18 (*ante*). The method used in some of the Merryweather fire pumps is to locate the crank shaft out of centre with the plungers, and to use a crosshead (*h*) extended in the form of a double plate outwards and downwards on one side, with the bottom end arranged to work in guide bars (*b*) on the side of the pump, and connected

to the crank shaft (*k*) by a long rod (*d*), as shown in Fig 196, the disposition of the crank shaft being in this case somewhat analogous to the Holly duplex engine shown at Fig. 19, and lends itself for the use of a comparatively long connecting-rod without increasing the height or length of the engine. The lightest and most compact form of double vertical fire pump is that shown at Fig. 197; the crank shaft here, it will be noted, is without flywheel, and only used to cause the plungers to work at full stroke, and to communicate motion to the two slide valves (*v*), the two cranks (*k*) in this construction being overhanging from a shaft

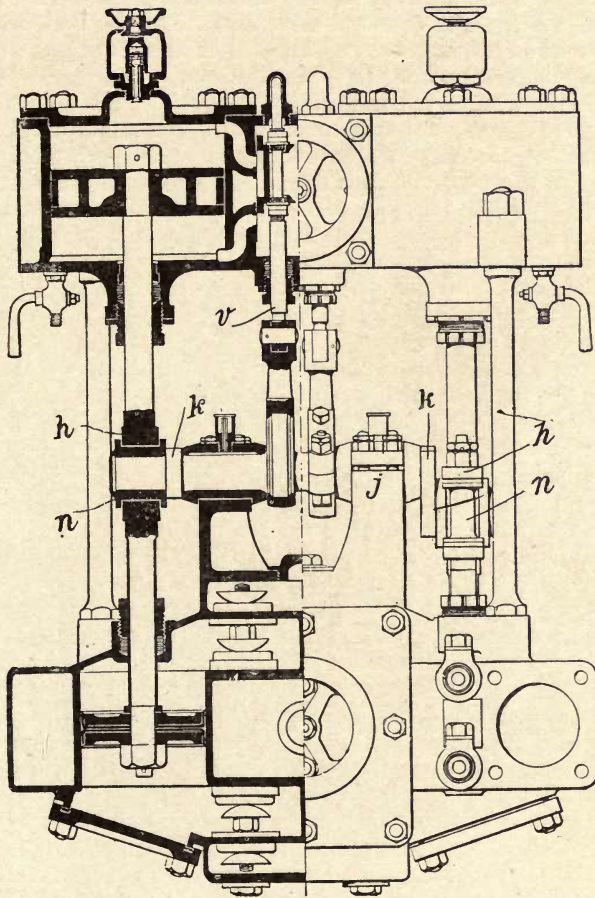

Fig. 197.—Merryweather Fire Pump (without Flywheel).

journalled in two bearings (*j*) carried by an extension upwards from the water end, the crossheads (*h*) taking the form of parallel bar guides for the crank-pin blocks (*n*). In the Shand-Mason double vertical, illustrated at Fig. 195, two flywheels are used, and a valve gear enabling the steam to be used expansively by a lever and quadrant, by which means the cut-off can be reduced from three-quarters, as at starting, to half-stroke, when at work; a dial-pointer shows the exact degree of expansion. Twenty-three engines of this type, including four

fitted on the fire float "Beta," were originally constructed for brigade use in London, and recent orders for land service have been fitted with oil-fuel apparatus for burning petroleum instead of coal. The oil burners consist of four intakes converging towards the centre of the firebox, the inner ends being perforated; projecting into each of these is an oil atomiser nozzle operated by a steam blast and oil under pressure. A somewhat similar apparatus, but arranged vertically and provided with a vena-contracta form of air intake, is used in some of the Merryweather engines.

The advantage resulting from the use of oil fuel is that steam pressure can be maintained with greater ease and steadiness than with coal, with an entire absence of sparks and flying cinders. Less attention is required while at work, and no cleaning out on returning to the fire station.

The usual time required to get up steam from cold to the working pressure of from 100 to 120 lbs. per square inch is from six to eight minutes while stationary, for average size engines; or, while travelling and without any stoking whatever, from eight to ten minutes. There is thus seen to be little necessity for stoking *en route*, which at the best is neither a safe nor an easy task, the fire being usually lighted on leaving the station. In order to accelerate "steaming," apparatus is adopted in the Shand-Mason coal-fired engines, consisting of a circular draught fan fitted in the funnel, which is actuated from the rear footboard by gear wheels and chain; by this means the time required for raising steam can be reduced to that obtained with oil fuel.

Although limited in heating surface, the transmission of heat in thermal units has been proved to be exceedingly high in boilers of the fire engine vertical water-tube type, the evaporation from cold being quite $6\frac{1}{2}$ lbs. per pound of coal, as ascertained on a six hours' full power test, and from 8 to 9 lbs. per pound of kerozene in a boiler with the furnace crown closely packed with solid-drawn hard brass tubes arranged at an angle in about a dozen rows, all of which are open to view at both ends on removing the outer shell.

British-made fire engines vary in size between 100 and 2,000 gallons of water pumped per minute, the vertical height to which different sized jets can be projected, ranging from 80 feet for a $\frac{1}{2}$ -inch jet, to some 200 feet for a 2-inch jet. From the point of view of power required, the smaller size will develop some 10 H.P., and the larger size more nearly 100 H.P. Between these capacities there are several standard sizes, comprising single, double, and treble vertical engines, as well as double-cylinder horizontal engines; also an increasing number of fire engines with petrol motor-driven multi-stage centrifugal pumps.

In order to reduce the time for getting under steam, it is customary to use either a gas or oil burner located in the furnace over the ready-laid firing, by which means, as in central stations, a steam pressure of about 20 lbs. can be maintained constantly, two or three minutes sufficing under these conditions to obtain the full working pressure. In other cases the water is heated to within a few degrees of boiling by an oil or gas burner, a gallon or so per 24 hours being found to be sufficient for this purpose. These circumstances all point in favour of the self-propelled engine, the general arrangement of which when using steam need not, therefore, be materially changed; and as the same type of boiler with engine located in front may be used, the fitting of a clutch-drive on to a balance gear chain sprocket shaft, together with a suitably modified carriage or chassis, constitutes the principal structural differences necessary. The saving effected in cutting out the expenses of the stables was more obvious than for any other vehicular traffic, as in hundreds of fire stations the engines were wont to be more often taken out to exercise the horses than for any purpose of real urgency.

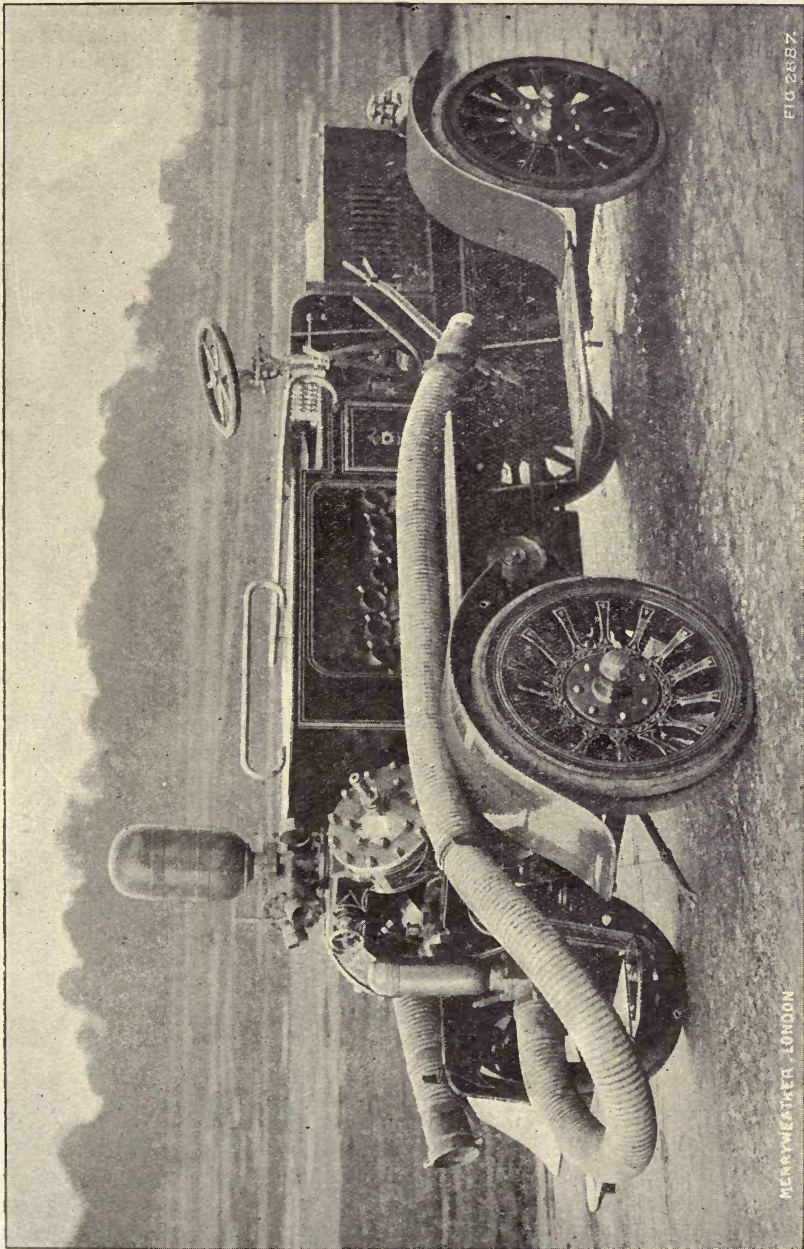

FIG 2887

MCARDWELL, LONDON

Fig. 198.—Motor Fire Engine for the Glasgow Fire Brigade. (Capable of projecting a 1½-inch jet to a height of 140 feet.)

From the use of oil fuel in the furnace of the steam-propelled fire engine, it is only another step to the internal-combustion motor, a means of propulsion

thoroughly justified by the success of the petrol automobile. Whatever exception may be taken to the use of a more expensive fuel in this application is more than compensated by the reduced call notice required, and to the higher speed obtainable on the road. The photo view (Fig. 198) illustrates a very practical example of the new class of motor fire engine,* in which a 4-cylinder petrol motor of 50 H.P. is used, the triple-action pump shown in the rear being

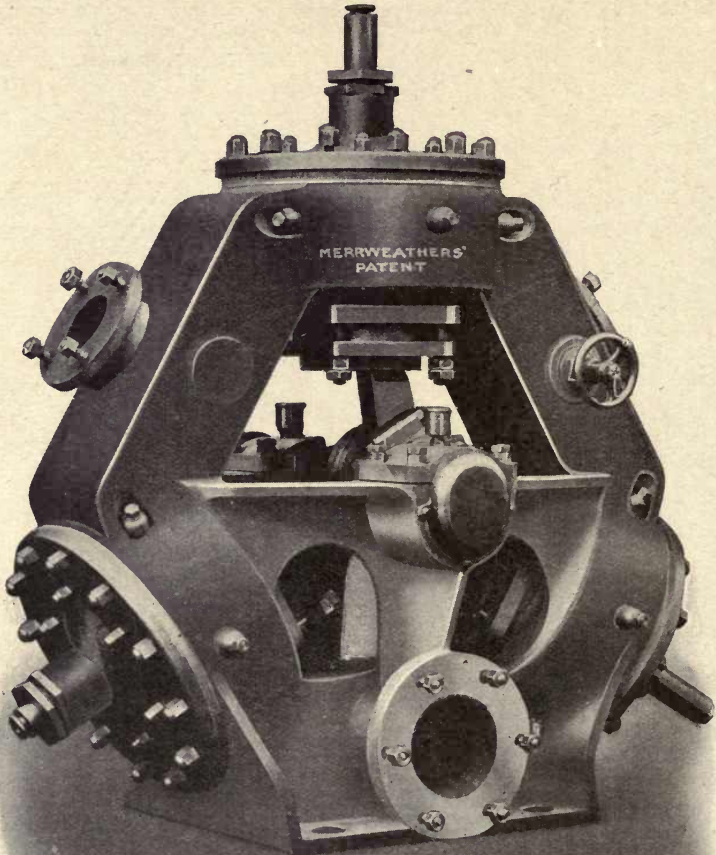

Merryweather, London

Fig. 277Z

Fig. 199.—Hatfield Fire Pump.

thrown out of gear when travelling on the road. This engine is capable of projecting a $1\frac{1}{2}$ -inch jet to a height of about 140 feet, and of drawing its supply from a depth of 27 to 28 feet; while its speed on the level, fully equipped with men and gear, may approach closely to 30 miles per hour. The pump (the most interesting feature of this engine) is shown at Fig. 199, from which it will be seen that there are three single-acting plungers, all actuated from a single-throw crank shaft.

* Petrol motor fire engines, such as the Dennis and Leyland, with turbo pumps, are preferred for connecting to town mains.

The triangular frame carrying the three pump barrels and sets of inlet and outlet valves is chambered, and forms a double belt right round the pump, one belt communicating with the inlet at the bottom, and the other with an outlet at

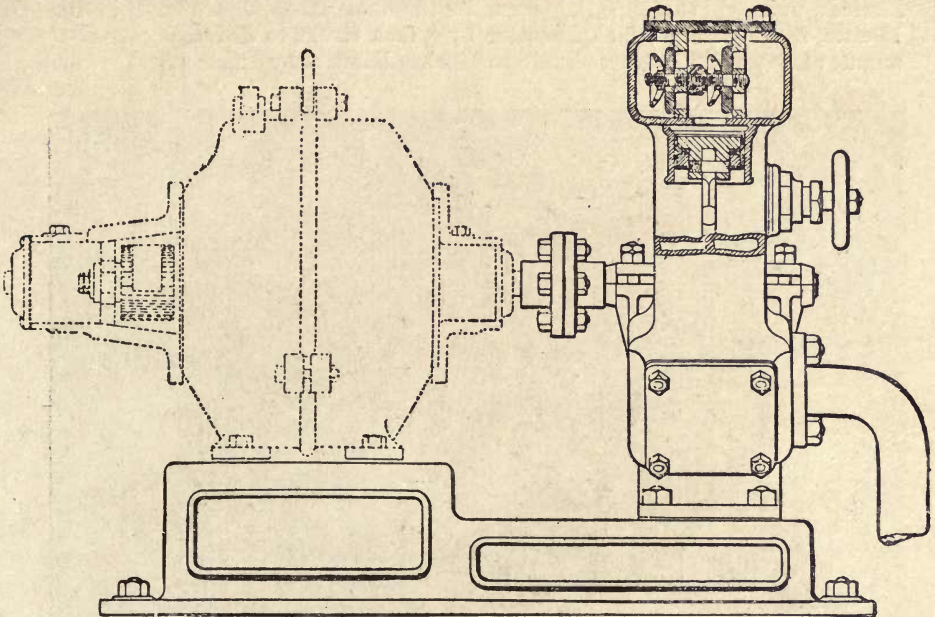

Fig. 200.—Part Sectional Elevation, showing Arrangement of Plungers and Valves in an Electrically-driven Hatfield Fire Pump.

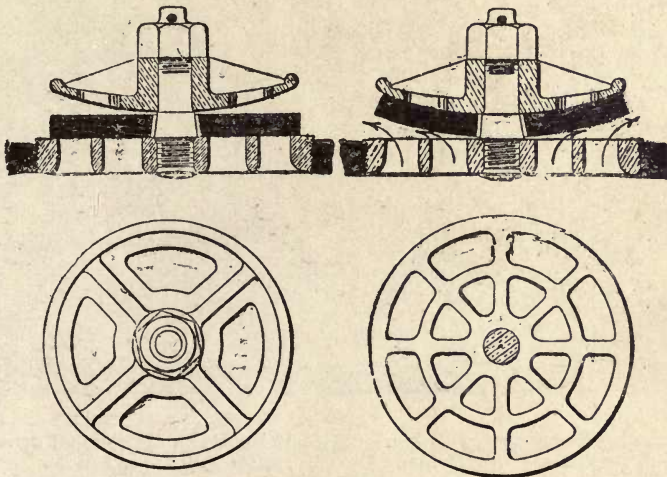

Fig. 201.—Sectional Elevations and Plans of Suction and Discharge Valves used in High-speed Fire Pumps.

either side; a by-pass is arranged between the two passages for use at starting. A part sectional view of a similar pump is shown at Fig. 200, arranged to be driven

direct from an electric motor, and represents one of an installation put down at Hatfield House, this being the first of a number since installed in country mansions to provide a high-pressure water service, and in towns for augmenting the pressure service; pumps of this type (known under the name Hatfield) are made in some 18 sizes, ranging from 1 inch diameter by $\frac{3}{4}$ inch stroke to deliver 9 gallons per minute at 700 revolutions per minute, to 9 inches diameter by 6 inches stroke, which

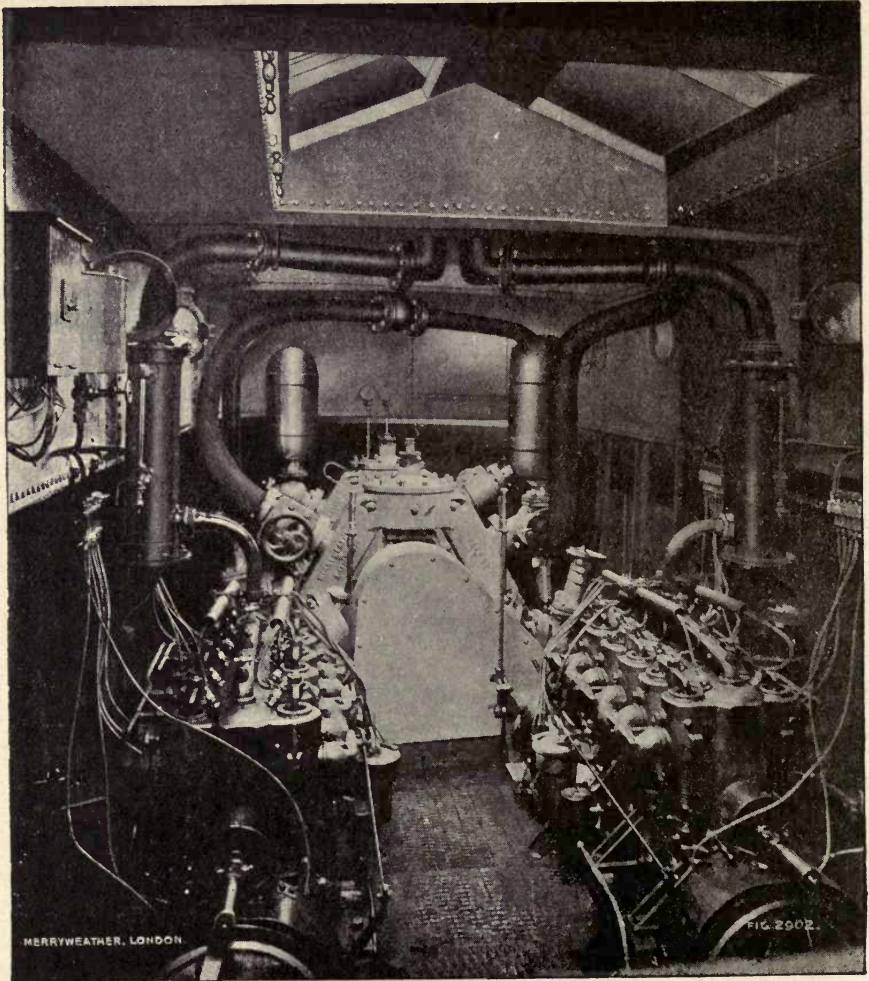

Fig. 202.—Engine Room, showing a Pair of Hatfield Pumps on a Fire Float driven by Two 6-cylinder Petrol Motors. Capacity, 1,200 Gallons per Minute.

latter size is capable of delivering 750 gallons per minute against a total head of 130 feet at 180 revolutions per minute; an installation of this size has been recently supplied for a gas power pumping plant, referred to in the following chapter.

The suction and discharge valves used in this pump, as in the preceding forms of high-speed fire pumps, are of the type shown at Fig. 201, the valves

either being of specially prepared rubber or of dermatine composition; the material in either case is sufficiently flexible to permit the valve to lift freely to the spherical guard as shown, this form of valve permitting a freer waterway

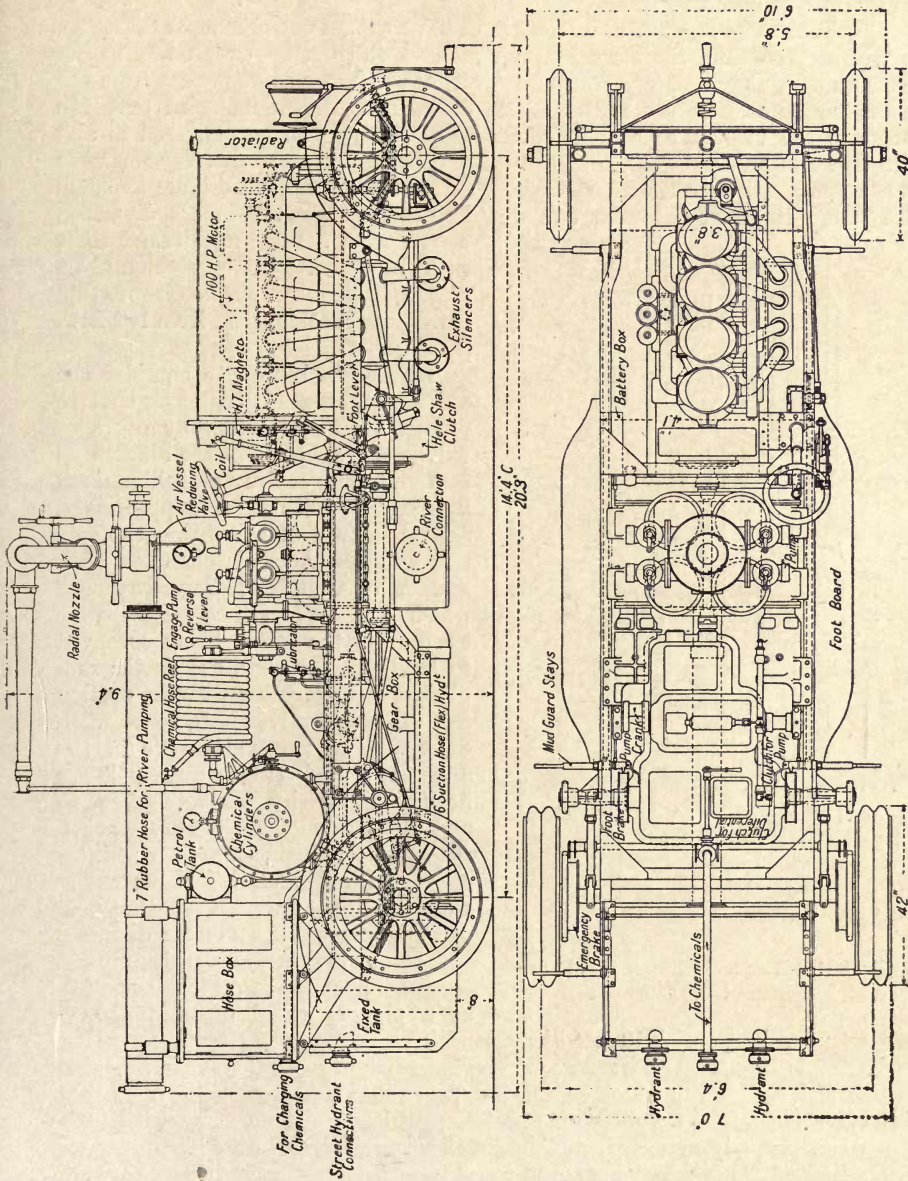

Fig. 203.—Petrol Motor Fire Engine with 2-throw Double-acting Force Pump for Tottenham.

than the disc valve when used in pumps having a high speed of rotation, and is with minor differences similar to the form of valve in most general use in condenser air pumps (*vide* Fig. 163, *ante*).

The illustration at Fig. 202 represents another adaptation of the Hatfield

pump to a twin screw fire-float for Rio Tinto; this installation comprises two sets of pumps, each of 600 gallons per minute capacity, and two sets of 6-cylinder 60 H.P. petrol motors, and the two pumps are so arranged that each motor can drive either or both together.

There are some features of interest in the Tottenham petrol motor fire engine, as will be seen from the elevation and plan views (Fig. 203) reproduced from *The Engineer*, the most important, however, of these, considered apart from the motor mechanism, is the radial nozzle or monitor shown mounted over the centre of the vehicle, as by this construction the jet can be delivered in any direction and at any angle, and being fed directly from the delivery chamber of the pump, all connecting pipes with consequent loss of pressure are avoided. The pump is horizontal with two double-acting plungers 7 inches diameter,

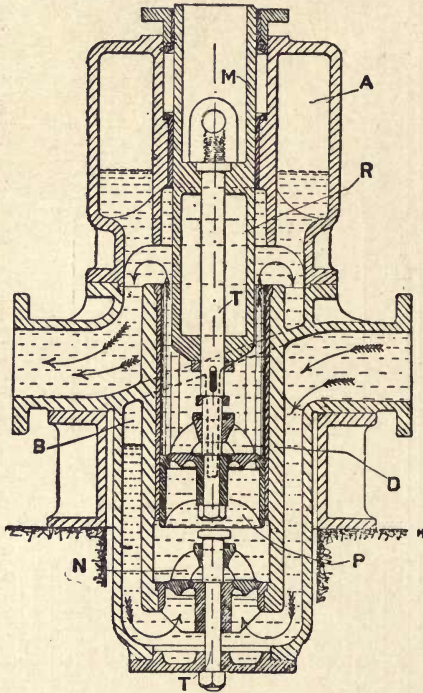

Fig. 204.—Ram and Plunger Fire Pump
(Rigg).

driven from a two-throw crank shaft with a 6-inch stroke, receiving its power through a multiple disc friction clutch and reducing gear from 100 H.P. petrol motor.

Before passing on to consider the different types of high-speed force pumps having mechanically operated valves, a description of the differential ram and plunger fire pump illustrated by Fig. 204 will not be inappropriate, special feature of this being the suction and discharge air chambers at B and A of unusually large capacity, which are both self-contained with the pump, the latter being arranged to be disconnected to enable the ram plunger P M, together with the suction and discharge valves N D, to be withdrawn. The two valves are of the annular seated ring type, and are firmly guided by central stems T, and each provided with rubber-packed stop sockets without springs; these afford with $\frac{1}{2}$ inch lift a waterway equal to about one-third the area of the plunger (viz., 9 inches diameter by 14 inches stroke), a pump of these dimensions working smoothly at a plunger speed of from 150 to

160 feet per minute, with 10 feet of suction lift.

Mechanically-actuated waterway valves are not in general use for pumping engines of large size, in which connection the rubber composition spring-backed disc valve is found to work with a sufficiently low resistance, and with little slip, when properly arranged, and in sufficient numbers to afford a waterway with a limited lift of $\frac{3}{8}$ to $\frac{1}{2}$ inch, and equal to or better, if exceeding the area of the plunger. Many difficulties present themselves in the application of positively-actuated suction or discharge valves to engines conforming to the conditions pertaining to water-supply stations; pumping engines for this purpose are usually of such dimensions as to require not only a valve of large diameter,

but one having a high lift in order to obtain the necessary opening. One peculiarity of lift valves consists in diminishing in efficiency with increase in diameter; thus a plunger of, say, 26 inches diameter working at a speed of 200 feet per minute is provided with at least 100 inlet and outlet valves, each of 4 inches external diameter, with a lift limited to from $\frac{3}{8}$ to $\frac{7}{16}$ inch, which is the number required to afford a waterway equal to the area of the plunger—viz., 530 square inches. A single valve of this capacity would require a diameter of 31 inches, and a lift of $5\frac{1}{2}$ inches; or, if three valves be used each must be allowed a lift of 3 inches, which would even then require to have a diameter of 19 inches; these facts sufficiently explain the prevailing practice of using multiple-lift valves in large pumps. This difficulty can be to a certain extent surmounted by the use of multiple-seated ring valves of pyramidal or conical form, as illustrated in Figs. 43 to 51, *ante*, by which means the lift may be reduced about one-half. However, there are no valves of this construction in use for the

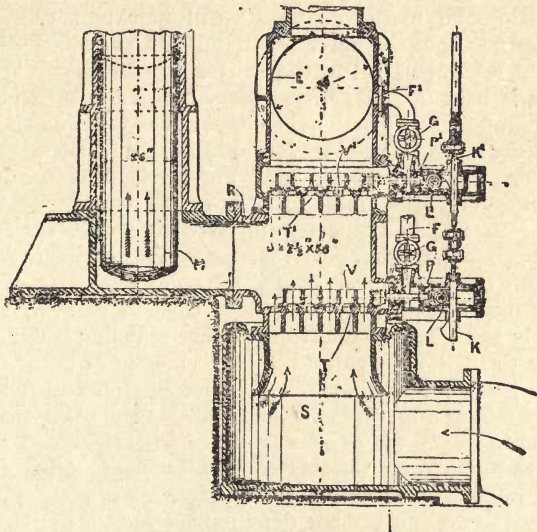

Fig. 205.—Sectional View of Waterworks Pumping Engine, showing Southwark Suction and Discharge Valves.

purpose named which are mechanically controlled, except certain flat-seated annular ported valves to be referred to later.

The ordinary slide valve, even if balanced against the pressure, would not be a good substitute, owing to the enormous size of valve that would be necessary to afford the required area of waterway. This drawback can, however, be got over by using a modified form of the multiple-seated grid slide of the kind well known in connection with blowing engines, and first introduced by the Southwark Foundry and Machine Company, of Philadelphia, U.S.A., who have adapted this type of valve to a water-supply engine of the 3-crank vertical single-acting ram plunger type of the kind illustrated by Fig. 18, *ante*; in the constructional arrangement of this most interesting form of valve, illustrated by the sectional view, Fig. 205, will be seen one of the set of three plungers represented by M, working in a pump barrel of usual construction. To the breech-end W of this pump, either at opposite sides or as shown, are connected the two valve chambers

R; the floor of each of these chambers is strongly ribbed, and formed with a series of port openings T and T¹, arranged laterally. Over these corresponding grid slide valves V and V¹ are traversed in one direction by the hydraulically-actuated pistons P and P¹, and in the reverse direction by the cam slides K and K¹, receiving their motion from the crank shaft.

The inner ends of the two pairs of motor pistons P and P¹ are connected to the discharge chamber R, or the delivery main E, by waterways F and F¹, controlled by the stop valves G. The *modus operandi* of this valve and gear is such that the suction valve will remain closed until the pressure in W is relieved by the return movement of the pump plunger M, at which moment the suction valve will be shot back by the water pressure from E, acting upon the piston P. Now, on completion of the up or suction stroke of M, the cam slide K will engage with the roller L and reverse the position of the valve, thus cutting off connection with the suction inlet at S. The action of the discharge valve is quite similar—*i.e.*, as soon as the pressure in W relieves the pressure on V¹ from the delivery main—the motor piston P¹ will quickly traverse the discharge valve to its open position, the valve remaining at the open position until closed by the slide cam K¹ at the end of the delivery or down stroke of M. In both cases the valve is held in the position placed by the cam slides until by the reversal of the pump plunger frictional contact of the valve on its seat is removed. Thus, it will be seen, the valve is traversed in both directions while in a state of balance, in the one direction mechanically and in the other automatically.

A Southwark valve constructed to afford a waterway equal to the area of a pump plunger 26 inches diameter will have six ports, each 2½ inches wide by 3¢ inches long; but as this only represents the restricted area of the vena-contracta form of the port openings, the effectual waterway area is equivalent to a valve opening considerably exceeding this; moreover, the direction of flow is absolutely straight through, thus further reducing water frictional resistance. In order to realise the full advantage capable of being derived from an improved valve gear of this kind, much larger suction and delivery mains are required, thus entailing a further additional cost to the plant than that involved by the extra mechanism. Its exact advantage will, therefore, not only depend on the increased pump duty obtainable, but on many other factors, some of which it will be impossible to estimate until after a few years' practical working, and up till now there is no further data forthcoming other than an improved piston speed from 210 feet per minute to 280 feet in a converted engine of 16 millions of gallons per 24 hours' capacity under normal conditions, this being equivalent to an increased plunger speed of 25 per cent., and it would seem that, with a suction lift limited to within 10 feet below the inlet valve, and with suction and delivery mains of the proportion shown, a considerably higher plunger speed than this would be practicable with a 3-throw pump provided with properly-proportioned air-balancing chambers at both ends. It is found that at whatever speed the pump is working there is no tendency for either valve to be forced off its seat, while in the open position, by the water flow, as with all forms of lift valves, which in all cases not only cause a deflection at right angles, but split the water flow into numerous fine streams. One of the results of high plunger speed with the automatically-closed lift valve of the disc or poppet form, even when allowed a very limited opening, is the additional loss due to want of synchronism of the valves with the plunger, a defect more noticeable with the action on the inlet than the discharge. Accordingly a pump constructed with a mechanically-closed suction valve may be run at a much higher speed, although in other respects but little different from ordinary practice.

In the Southwark multiple-ported slide or grid valve the closing action is not affected by the momentum imparted to the water column to any appreciable extent, and the valve is allowed to remain fully open until the crank has approached to within 25° of the end of the suction stroke, when the closing action only occupies a period of 30° of the crank orbit. The time limit for the opening of the suction ports is determined by the adjustment of the regulator between the valve motor piston and the pressure main, the valve being pulled over hydraulically within a period of 10° or 12° of the water stroke of the pump plunger; the outer end of the valve piston, with its cylindrical guide, takes the form of an air-cushioning chamber to permit of the valve quickly opening without shock. The action of the discharge valve is practically identical to the suction valve, the opening taking place within 10° or so of the closing of the inlet, and the closing according to the formation of the actuating cam. In this connection, it may be pointed out that this form of valve may be arranged to be closed as well as opened by water pressure, in which case the cam slides K and K¹ are substituted by pilot valves, the action of which, it is needless to add, can be adjusted to work both silently and smoothly, and thus make it feasible to eliminate the one drawback of this gear for waterworks engines of large size. The mechanical method, however, as exemplified, affords a clearer conception of the working of this valve than would be possible if the necessary details for its closing as well as opening by hydraulic means had been described.

During the process of the investigation of the advantages to be obtained by adopting a properly designed mechanically-controlled device for the closing of both suction and discharge valves used in pumps required to be run at a higher plunger speed than 200 feet per minute, there may with some justice be mentioned the early improvements effected in this connection by Riedler, who, by a carefully-conducted series of experiments, ascertained that a much greater loss was attributable to the resistance caused by the splitting up of the water flow to and from the pump chamber into a number of annular jets than was hitherto supposed, and in order to reduce the throttling effect resulting from the use of a multiple series of disc or poppet valves, restricted in lift to an opening of $\frac{1}{4}$ to $\frac{3}{8}$ inch to minimise slip, Riedler designed his pump with one suction and one discharge valve of large diameter, both of these being free to lift in synchronism with the movement of the plunger, but were closed by a tappet gear with a positive action irrespective of speed. The working of pumps with mechanically-controlled valves was found to be so successful as to lead to their manufacture in considerable numbers, with the result that, so far, some 1,500 pumps have been constructed on this particular system for mining purposes in different parts of the world. Riedler pumps in the smaller sizes are usually constructed to work on the double-acting principle with differential rams, as first introduced by Sir W. Armstrong at Elswick, the action and construction of the valves being illustrated by the diagrammatic sectional cut (Fig. 206) and exterior view (Fig. 207), from which it will be seen that the valves (*d*) and (*s*) are of identical form, each having an annular waterway and a double ring ported flat-faced seat.

The seats (*a*) and (*e*) are held down by pins removable from the outside, and the valves which are guided by central stems are permitted a lift ranging from $\frac{3}{4}$ inch in a pump having differential plunger rams $3\frac{3}{4}$ by $2\frac{5}{8}$ inches diameter and 12 inches stroke, and capable of delivering 70 gallons at a speed of 1:0 revolutions per minute, to $1\frac{1}{2}$ inches lift in a pump with $9\frac{1}{2}$ by $6\frac{3}{4}$ inches diameter plungers and 36 inches stroke, having a capacity of 700 gallons per minute at 80 revolutions per minute. In addition to pumps of the differential type, others

fitted with Riedler valves are made for much larger outputs, arranged in pairs to work duplex fashion direct from a compound engine with central flywheel and outside cranks, the pumps in this case being of the Knowles hydraulic double-acting type with outside packed ram plungers and side rods. One of

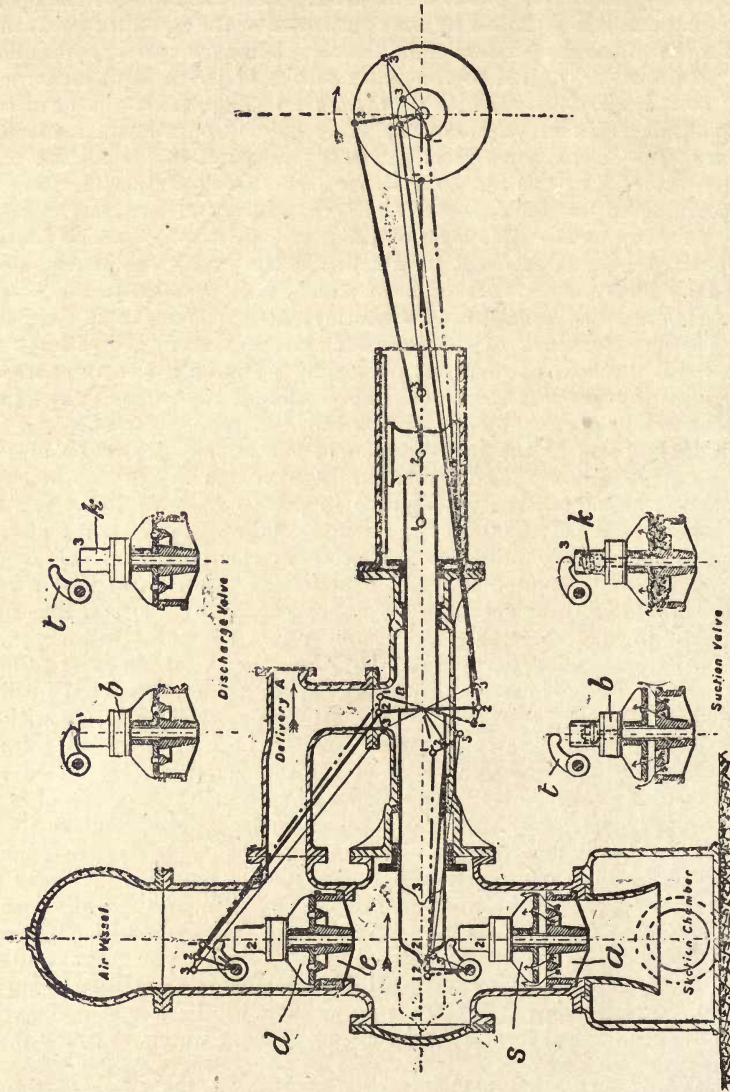

Fig. 206.—Section of Differential Pump, showing Action of Riedler Mechanically-controlled Suction and Discharge Valves.

this type recently put down at the Powell-Duffryn Collieries, in South Wales, has a capacity of 1,000 gallons per minute against a head of 1,600 feet, at a normal working speed of 40 revolutions per minute; but is capable of being speeded up beyond this 50 per cent., when a power equivalent to 720 W.H.P. and 900 I.H.P. can be developed at an efficiency of 80 per cent.

The dimensions of this pump are as follows :—Four rams, $6\frac{7}{8}$ inches diameter ; high-pressure cylinder, 35 inches ; low-pressure cylinder, 57 inches diameter ; stroke, 48 inches ; boiler pressure, 80 lbs. per square inch, the plunger speed of this pump varying from 320 to 480 feet per minute. Only one suction and one delivery main are employed, with one common suction box for the two pumps, in which a cushioning effect is produced by the air entrapped above the level of the suction inlets. The cushioning chamber at the delivery end is maintained at a pressure corresponding with the pressure head by a small compressor with single-acting plungers 3 and $7\frac{3}{4}$ inches diameter by 7 inches stroke, arranged to work compound, the air chamber over each pump being provided with air pressure and water-level gauges. In this connection it may be useful to add that it is important that air bells or cushioning chambers properly proportioned to the working pressure should be arranged immediately over or as close to the delivery valve chambers as possible, in order to be able to absorb the momentum of the water column ; also that the internal diameter of these should not be less than the plunger, and further, that the height with natural compression be not less than the square of the diameter in inches multiplied by the pressure due to water head in atmospheres.

The advantage of high-speed pumps when used at deep levels is not confined to the reduced weight and size of the pump itself, but is extended to the uptake, in which, with a water column running into thousands of feet in length, it is of the utmost importance to preserve a constant velocity of outflow. It is more due to this than any other cause that high-speed pumps have been so much in demand for mining purposes ; but before passing on to others of this kind, it will be interesting to further explain the working of the Riedler controlling gear, illustrated at Figs. 206 and 207. The valves are here shown in three separate views for the positions marked 1, 2, and 3 of the charging stroke, the various parts of the gear, valves, and tappets being figured to correspond with the positions 1, 2, and 3 of the crank. Over each valve is a pair of tappet fingers (*t*), which contact with the cap (*k*) at a point about 140° of the suction and delivery strokes ; by this means either valve can be positively closed at the ends of the stroke, independently of the speed of the plunger. Rubber buffers (*b*) permit the valves to be held down firmly to their seats and compensate for the valves not being able to close at any time on account of hard substances so frequently contained in mine water ; these buffers also absorb shock from contact of the valve cap with the stop provided to limit the lift on the valve stem. The valves are constructed of bronze composition with a flat seat of considerable surface, and partly owing to water resistance and to a film on the contact area, settle quietly at high speeds. The diameter of a Riedler valve is rather more than double that of the plunger,

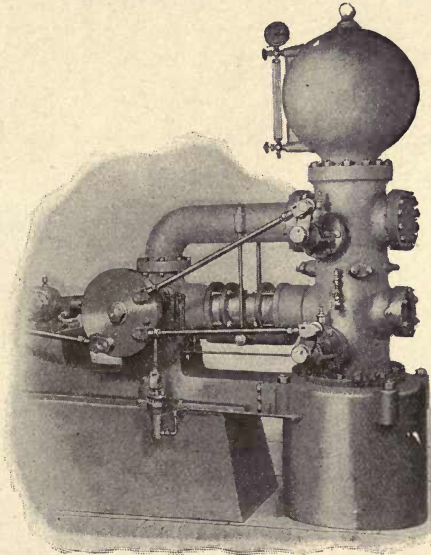

Fig. 207.—Elevation of Riedler Differential Pump, showing Actuating Gear.

The valves are here shown in three separate views for the positions marked 1, 2, and 3 of the charging stroke, the various parts of the gear, valves, and tappets being figured to correspond with the positions 1, 2, and 3 of the crank. Over each valve is a pair of tappet fingers (*t*), which contact with the cap (*k*) at a point about 140° of the suction and delivery strokes ; by this means either valve can be positively closed at the ends of the stroke, independently of the speed of the plunger. Rubber buffers (*b*) permit the valves to be held down firmly to their seats and compensate for the valves not being able to close at any time on account of hard substances so frequently contained in mine water ; these buffers also absorb shock from contact of the valve cap with the stop provided to limit the lift on the valve stem. The valves are constructed of bronze composition with a flat seat of considerable surface, and partly owing to water resistance and to a film on the contact area, settle quietly at high speeds. The diameter of a Riedler valve is rather more than double that of the plunger,

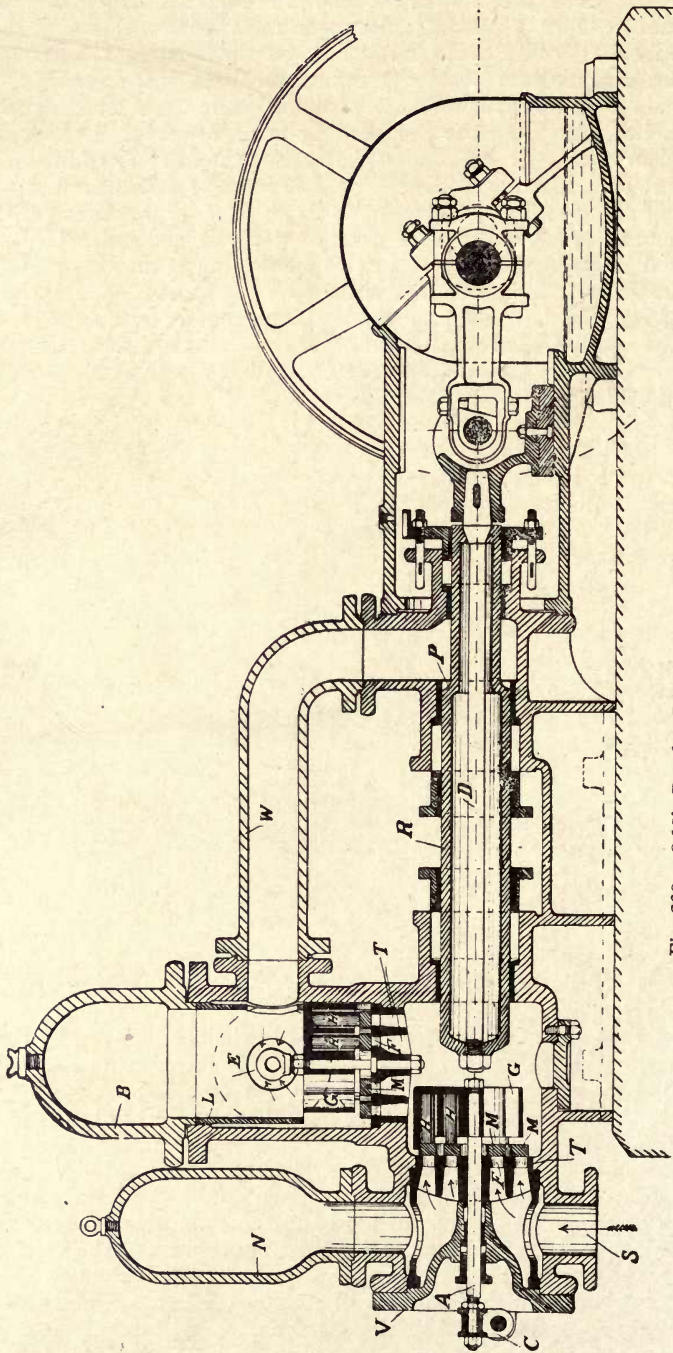

Fig. 208.—Oddie-Barclay Differential High-speed Force Pump.

and affords a waterway opening equal to and in some cases exceeding the area of the plunger when opening to its full lift.

In a modified construction of high-speed pump known as the Stumpf, and in its improved form as the Fraser & Chalmers express, which is a 2-throw single-acting pump, the suction valve is annular and located on an annular seat surrounding the ram plunger, by which it is forcibly closed during the period occupied by the plunger in completing the last tenth of its charging stroke, a buffer cap provided with a rubber ring being bolted to the end of the plunger for this purpose. The lift allowed to the inlet valve of a Stumpf pump with plunger $5\frac{1}{4}$ inches diameter by 7 inches stroke may be $\frac{5}{8}$ inch, and can afford a waterway opening equal to $1\frac{1}{2}$ times the area of the plunger. The delivery valve in this pump consists of a double ring construction closing on to two annular waterways, no actuating gear being used other than the closing buffer cap on the plunger; the capacity of a 2-throw pump of the size named exceeds 300 gallons per minute against a head of 1,500 feet; and at the full speed of the pump of 320 revolutions per minute, the effective horse-power required does not exceed 280, which power, based on an efficiency of 80 per cent. for the engine and dynamo, 95 per cent. for the cable, 93 per cent. for the electric motor, and 86 per cent. for the pumps, represents an overall mechanical efficiency between the prime mover and the water delivered equal to 60 per cent., the increased cost of the direct-coupled motor being compensated by the saving in gearing.

The Oddie-Barclay high-speed pump, illustrated by Figs. 208 to 211, differs somewhat from the foregoing in using (1) mechanical control for the closing of the suction valve only; (2) an improved form of valve; (3) a differential actuating gear. High-speed pumps of this type are usually arranged for being rope- or belt-driven, and to work on the differential principle. Referring to the sectional illustration (Fig. 208), we find a valve somewhat similar in construction to that shown by Fig. 206, both valves having annular-ported seats; the Oddie-Barclay valve differs, however, in being lighter in construction, and in the cushioning method employed. This valve is in reality a double ring of special bronze, each ring M resting flat on its seat T, on which it is guided by wings F, which are inclined slightly to communicate a rotative effect to the valve, a result obtained in the Riedler valve by using inclined vanes in the seat. One of the difficulties experienced in the working of lift valves of large diameter is the equalising of the wear distribution over the entire face; this difficulty is got over in the Oddie-Barclay valve by using independent valves for the two annular openings in the seat, by which means, not only is the wear equalised, but either section when prevented from seating by water impurities will not hold up the other section. Each section of the valve is held down by an annular buffer H of rubber composition, both of which are carried by the metallic guide G, this also serving as a stop to limit the lift of the valve. The suction valve only is mechanically controlled, the spindle A passing through the cover V, which is utilised to hold down the seat T, receives for this purpose motion from the crank C. This crank is oscillated by the crank *b* (*vide* Fig. 209), and an eccentric gear actuated from the main shaft. The disposition of (*c*) and (*b*) is such that the spindle (*a*) and guide G close, and permit the valve to open more gradually than if (*c*) were at right angles to (*b*). A pin (*d*) carried by (*c*) communicates this motion to the valve buffer stop (*g*) through the sliding block (*f*) and motion bar (*e*) carried by the spindle (*a*), the arrows 1 and 2 indicate the opening movement, the springs (*h*) corresponding to the rubber buffers H shown in Figs. 208 and 210.

The Armstrong differential plunger ram P is bolted to the rod D, which is in turn cottared to the crosshead. Two cushioning chambers are used, one at N to equalise the suction flow from S, and a compressed-air chamber at B to balance the delivery flow to E; this bell also retains the discharge valve seat in place by the sleeve L. Compressed air is forced into B by a small pump actuated by the same gear as used for the suction valve, the diameter of the plunger being proportioned to the pressure head. The communicating pipe W, in conjunction with the two ends R and P of the differential plunger, serves as in all pumps of this type to distribute the delivery flow equally over the two strokes of the pump.

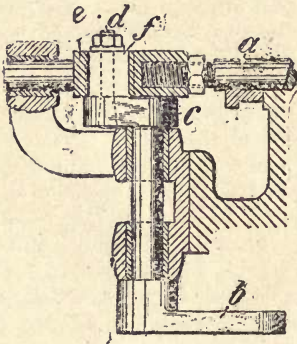
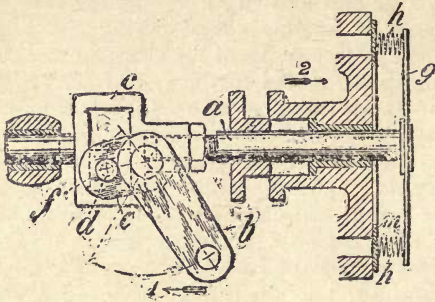

Fig. 209.—Details of Valve Gear of Oddie-Barclay Pump.

The sectional view (Fig. 210) represents one of a pair of single-acting ram plunger pumps supplied to the Tarbrax Oil Company, Lanarkshire, N.B.; these pumps are located in a small chamber near the pit bottom, and deliver up to 600 gallons per minute against a pressure head of 450 feet at a speed of 130 revolutions per minute, which is equivalent to 82 actual water horse-power. The plungers are $8\frac{1}{2}$ by 12 inches stroke, and are belt-driven from an electric motor of 100 H.P., supplied with current at 420 volts.

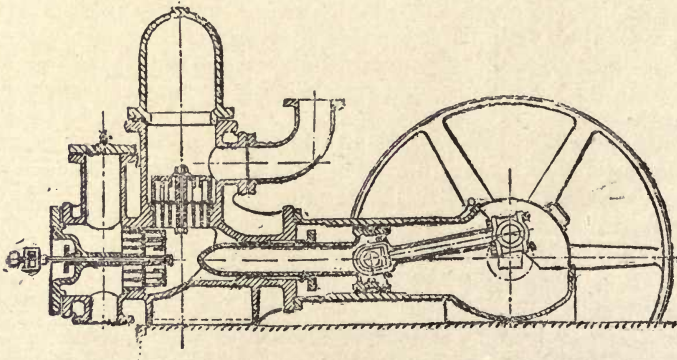

Fig. 210.—Sectional Elevation of One of a Pair of $8\frac{1}{2} \times 12$ inch Oddie-Barclay Mine Pumps. Capacity, 600 Gallons per Minute.

TESTS OF ODDIE-BARCLAY (5 and 7 ¹/₁₆ INCHES DIAMETER × 9 INCHES STROKE) PUMP.

No. of Test.	Date of Test.	Size of Pulley on Motor.	Volts.	Ampères.	E. I. P. at Motor.	Pump Speed at E.P.M.	No. 1 Gauge Reading (without Syphon).	No. 2 Gauge Reading (with Syphon).	Equivalent Head.	Gallons per Minute.	Calculated Displacement (in gallons).	Mechanical Efficiency of Whole Plant (per cent).	Efficiency of Pump (per cent. Water H.P. ÷ Power at Shaft).
2	23-8-07	26" dia.	195	325	85	173	433	438	1019.5	214	220	77.75	87.1
4	"	"	195	295	77	175	390	395	912.5	218	232	78.25	87.8
6	"	"	195	270	70.7	177	350	350	815.5	220	225	76.8	86.5
7	"	"	198	240	63.75	181	300	300	700.5	228	230	76	86
10	24-8-07	"	197	215	56.75	182	268	268	625.5	228	232	76	86.5
11	"	"	197	188	49.6	184	220	220	515	233	234	73.5	83.2
14	"	"	200	160	43	190	172	172	404.5	238	242	77.1	83.2
21	25-8-07	22" dia.	204	280	76.5	158	440	445	1039.5	194	201	79	88.6
22	"	"	202	255	69	160	393	395	917.5	198	204	79.75	89.3
25	"	"	204	235	64.2	163	360	360	838	201	207	79.49	89
26	"	"	206	210	58	165	303	303	707.5	206	210	76.4	85.9
29	"	"	202	182	49.2	167	255	257	599.5	205	212	75.5	85.7
31	"	"	204	165	45	168	225	225	528	209	214	74.75	85
33	"	"	205	145	40	170	186	180	433	213	216	69.8	79.9
40	29-8-07	20" dia.	198	253	67.2	141	435	440	1022.5	173	179	79.8	89.6
42	"	"	199	227	60.5	144	385	390	903.5	177	183	80.2	90.5
43	"	"	200	212	56.8	146	350	350	815.5	180	186	78	88.7
45	"	"	201	187	50.3	150	300	300	700.5	184	191	77.8	87.5
47	"	"	202	170	46	152	260	260	607.5	188	193	75.2	85.7
50	30-8-07	"	202	148	40	154	223	223	523	189	196	75.5	86.5
51	"	"	202	123	33.3	155	172	170	402.5	192	197	70.2	82

Fig. 211 illustrates another double-acting belt-driven pump of this make, with outside-packed plungers 8 inches diameter and 15 inches stroke, built to deliver 600 gallons per minute; this view also shows the general construction of the valve gear and other characteristics of interest; the subjoined results were obtained from a series of tests carried out with a differential pump of this type, and indicate the high efficiency and speed a pump with mechanically actuated suction valve can be run at.

The importance of continuing the water flow as far as possible in one unbroken column has long been recognised, and explains the *raison d'être* of the Haste pump for low lifts, in which the only valve necessary is a solid cone of rubber composite material located in an enlarged section of a double-ended hollow plunger, which connects and reciprocates in suction and delivery barrels placed end to end. The most usual method for actuating this pump is by side rods connecting gudgeon pins on the valve box to a crank shaft at one end, a slipper

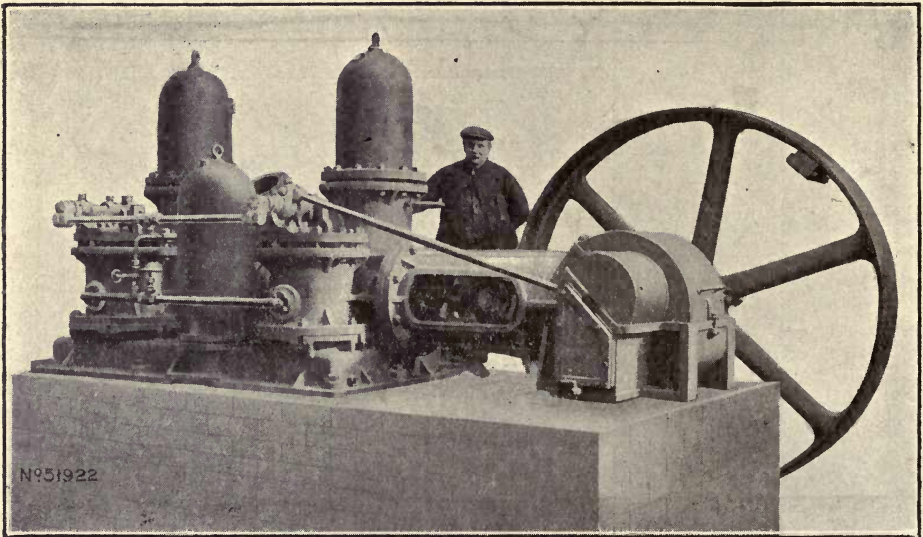

Fig. 211.—Double-acting Belt-driven Oddie-Barclay Pump. (Rams, 8 × 15 Inches Stroke.)

guide being provided for the purpose of carrying the plunger and its contents, as well as to neutralise the angular thrust produced. In action the thinly-walled taper-ended plunger of this pump slips over the water column put in motion by the preceding forward strokes without measurably retarding its movement; the conical valve meanwhile automatically opens to afford a free passage of the moving column to the discharge end of the pump.

The velocity of the moving column produced in this manner, although never exceeding the maximum plunger speed, is not permitted to fall quite to zero except at high pressure heads; and, indeed, the flow which can be produced by this means with one plunger is almost continuous under favourable circumstances, and may exceed the volumetric displacement of the plunger from 25 to even 100 per cent. when the speeding of the pump is most advantageously adjusted to a low pressure head.

The mechanical efficiency that can be obtained with a single plunger pump of this construction is probably higher than can be obtained in any other high-speed pump provided with the ordinary form of valve, owing (1) to the reduced deflection imparted to the water flow, (2) to the absence of spring resistance, and (3) to the utilisation of momentum effect both for opening and closing the valve, as it clearly follows: the plunger must commence each stroke in advance of the valve, by which movement the valve is opened on the return stroke and closed at the commencement of the forward stroke of the plunger. (Owing to this action, and the conical valve used, a mechanical efficiency has been obtained with a crank-driven pump as high as 90 per cent.) In adapting this principle where the pressure head exceeds the momentum effect of the water column, a suction valve of similar construction is used, and for lifts exceeding 100 feet a retaining valve is found advisable, the foot valve only being necessary when the suction lift exceeds 10 feet to 15 feet, in order to facilitate starting.

The Haste pump is more usually constructed in single horizontal crank-driven units, a pump with a plunger stroke of 16 inches having a working speed of from 60 to 80 revolutions per minute; but is also made with a 2-throw crank, for conditions where limitations of space count for more than other considerations when it is supplied in the vertical form. The *modus operandi* will be easily gathered by the following description in reference

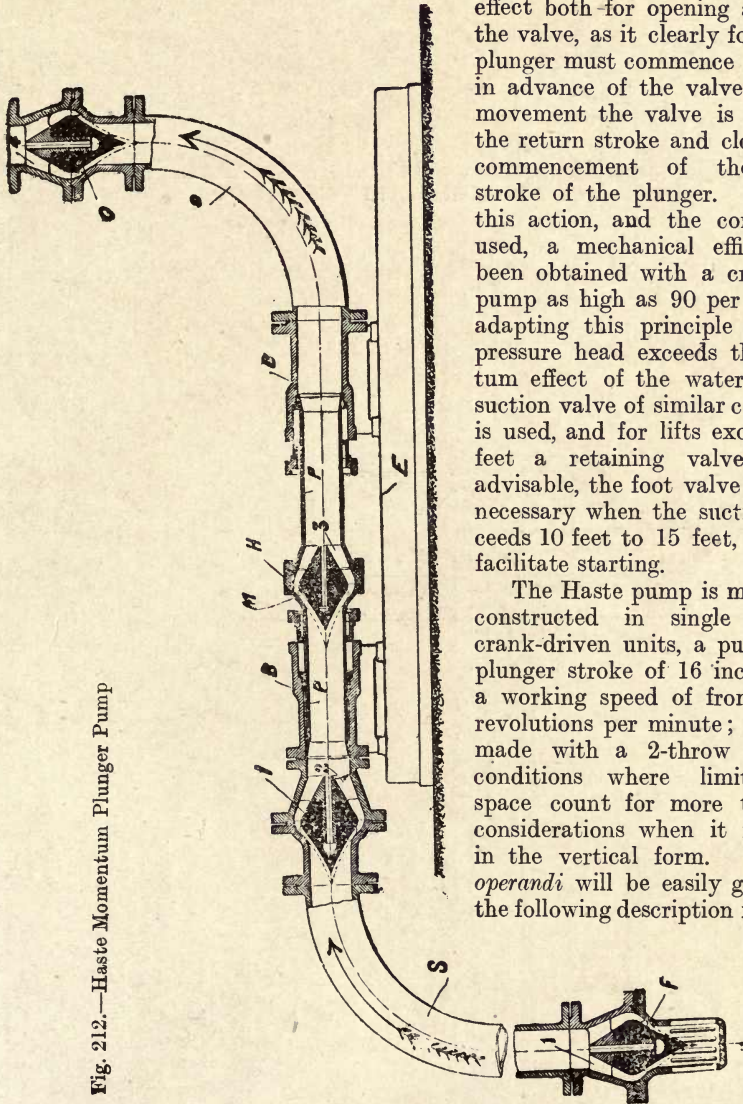

Fig. 212.—Haste Momentum Plunger Pump

to the sectional drawing (Fig. 212), where an example is illustrated of the principal features in a pump adapted both for a high suction lift and high pressure head; the conical composition valves F, I, M, and O representing the foot, suction, plunger, and pressure head or retaining valves respectively,

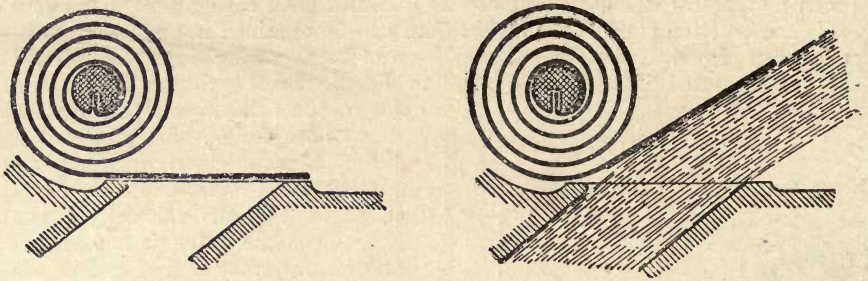

Fig. 213.—Section of 16-coiled Spring Flaps used in Gutermuth Suction and Delivery Valves for Fraser Chalmers' High speed 3-throw Pump.

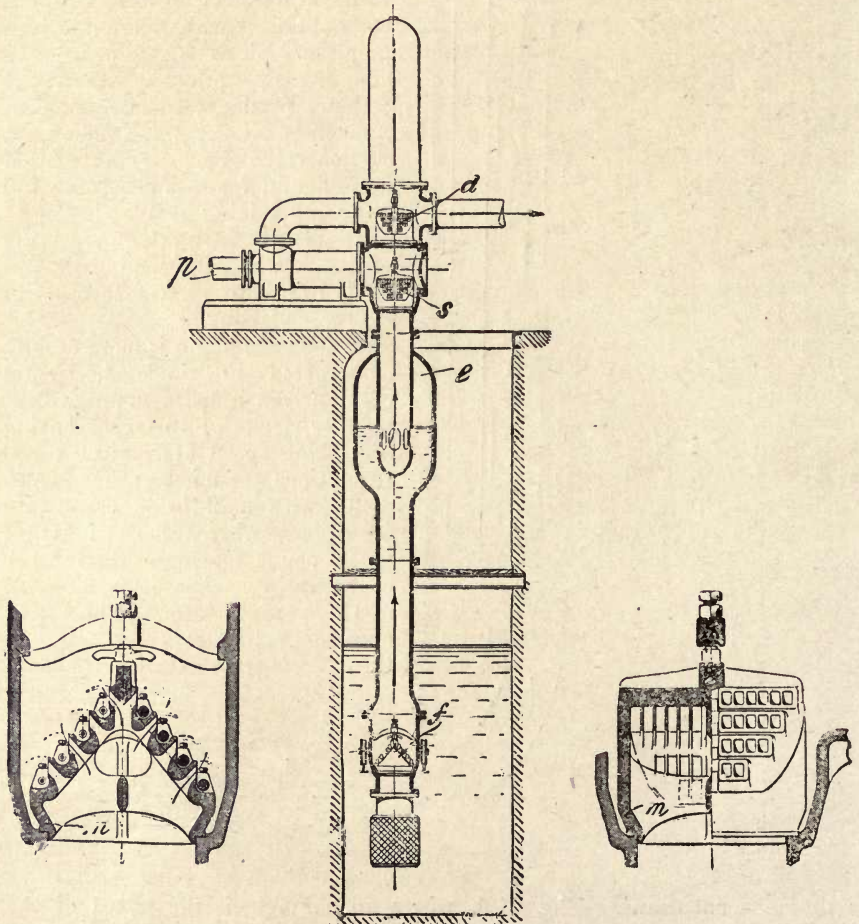

Fig. 214.—Details of a Differential Pump at the Woodford Pumping Station fitted with Gutermuth Valves.

working on guide stems carried by the valve boxes 1, 2, 3, and 4. P F is a double-ended hollow plunger with tapering outer ends, the inner ends, together with the crosshead H, constituting the guide, seat, and waterway for the momentum water accelerating valve M. The outer ends of the plunger reciprocate in the gland-packed barrels B B, carried by the foundation frame E, which is extended at the delivery end D to support two journals for the driving-shaft, not shown.

The lightest form of valve known, and one peculiarly adapted for being arranged in multiple, is the Gutermuth metallic flap or hair spring valve, which, in addition to its sensitiveness to pressure, affords a freer waterway than a multiple ring valve or a series of disc valves, such as most generally used in waterworks pumps of large size. This valve, as will be seen by the illustration (Fig. 213), is formed from a long strip of sheet metal, 1 to 2 mm. thick, which is coiled from 3 to 6 times about a mandril, on to which the inner end is held by a slot, and in this manner the tension of the valve can be very nicely adjusted by a key. This form of valve is obviously of considerable elasticity, and in this respect has an advantage over leather or rubber flaps for pumps required to be run at high speeds; in fact, the force required to raise a valve, 4 inches wide, 3 inches long, and 1 mm. thick, with four coils, to an angle of 30° , is only 2 lbs., which works out at 0.25 lb. per square inch, and bears but a small proportion to the working pressure such a valve may be used for—viz., 200 lbs. per square inch—a further advantage results from a certain wiping action in closing, from which cause the valve requires no grinding on to its seat, and owing to its extreme lightness is not subject to excessive wear. As an instance of the throttling effect of the ordinary ring valve, as used in many of the earlier types of waterworks pumping engines, a differential pump with plunger 11 and 15.5 inches diameter by 36 inches stroke, at the Woodford Pumping Station of the Metropolitan Water Board, on being fitted with Gutermuth valves, as shown in Fig. 214, could be speeded up from 28 to 35-40 revolutions per minute, against the same head of 250 feet as before. In this pump there are three valves (*f, s, d*), with a large air-equalising chamber (*e*) between the foot valve and suction valve. The old delivery valve weighed over 1 cwt., and the foot valve nearly $\frac{3}{4}$ cwt., whereas the new valves for each seat weigh 11 lbs., and only a small part of this is put in motion, which fact, apart from the increased waterway afforded by the spring valves, is quite sufficient to account for the higher output of the pump, recognising that at each suction stroke 2.7 cwts. of iron had to be kept floating for raising 24 gallons of water. However, the full advantage of a light valve can only be appreciated in a pump required to be run at a high linear as well as a high angular speed, under which conditions the importance of a free and unobstructed waterway cannot be over-rated, and with this object in view this form of valve has been adopted in two sets of 3-throw mine pumps, each to raise 1,000 gallons per minute against a head of 750 feet, section elevation and plan views of which are illustrated by Figs. 215, 216, and 217. These high-speed pumps have plungers $6\frac{3}{4}$ inches diameter by 16 inches stroke, and are designed to be run at a speed of 180 revolutions per minute—i.e., at a plunger speed of 480 feet per minute—direct from two 275 H.P. 3-phase motors Z, through flexible couplings H.

The pump bodies are mounted on a common suction air vessel I (Fig. 216) of cylindrical form, which acts in part as a bedplate. On this tank is cast a branch flange for connecting up to the suction main S, and over the pump bodies is bolted the longitudinal air vessel A, having flanged branches for connecting up to the three delivery chambers, and an end flange to connect with a retaining valve V communicating with the delivery main at D.

The bedplate carrying the driving shaft and motion bars is of the internal-combustion engine type with outhung pump barrels and main bearings with 2-part babbitted liners. The connecting-rods are made in cast steel with marine type babbitted ends for the crank pins, the gudgeon ends driving on to crossheads bolted to gun-metal plungers P (Fig. 215) with pointed ends.

The valves, which are perhaps the most interesting part of the pump, are mounted on cylindrical bronze seats G, each pump having one set for suction, and one for delivery. These seats are held in place by means of wedges E, tightened by the bolts B, and are readily accessible when the valve covers at G are removed. The valves themselves are of the coiled metallic sheet type of special bronze, and are proportioned to afford a waterway unattainable by any other form of automatic valve, the action being illustrated by the sectional views (Fig. 213), showing one of the coiled spring valves in open and closed

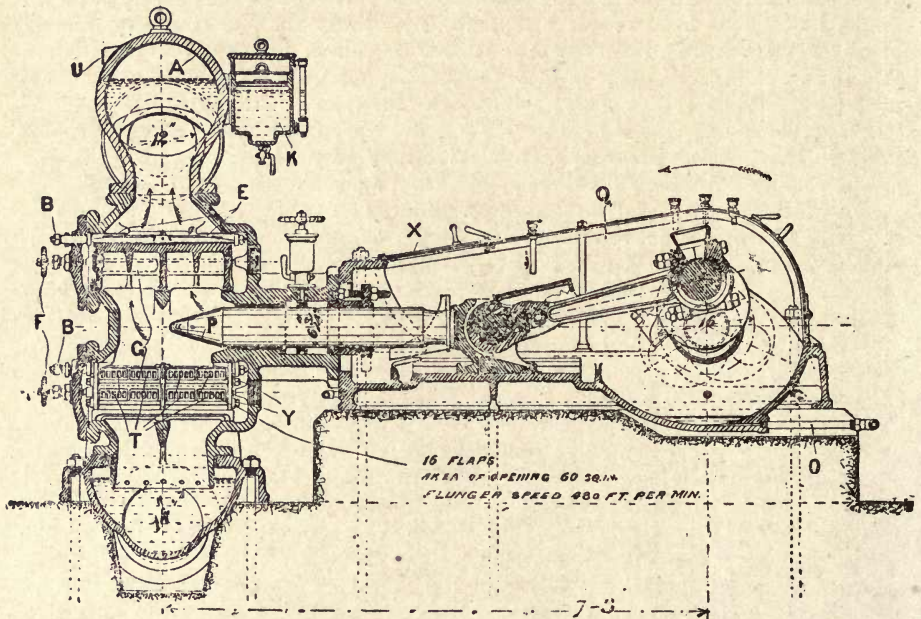

Fig. 215.—Sectional Elevation of Fraser and Chalmers' 3-throw Pump with Gutermuth Valves.

positions. These valves are slipped on to spindles Y, provided with recesses, as shown for carrying the inner ends of the coils, the spindles being clamped to the valve seats at the desired tension. The waterway 5-bar openings T are inclined in a direction away from the valves, which close with a slight wiping action, thereby tending to ensure a perfectly tight fit, although so sensitive to the action of the water flow as to be deflected almost to the angle of the outlets at the velocity produced by the ordinary working speed of the plungers. One complete set of 16 flaps affords an area of opening equal to 60 square inches—i.e., a waterway 1.6 times the area of the plunger—and can be withdrawn without trouble (no gear whatever having to be dismantled) on removing the keep at the end, and as the complete sets are all interchangeable, the replacing of any one is an easy matter.

The sectional end view (Fig. 216) shows distinctly the very straight and unobstructed port openings through which the water passes, as it were, in a solid mass, and without breaking up and forming eddies as is unavoidable with

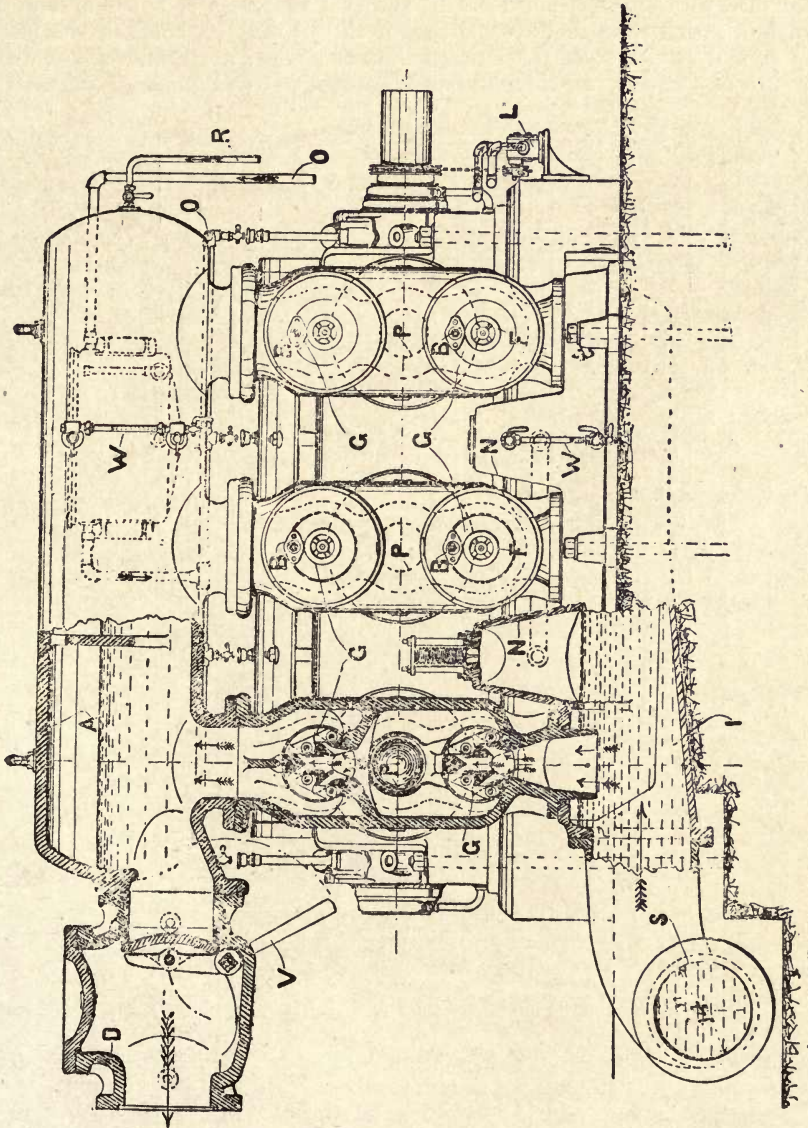

Fig. 216.—End Elevation of Fraser and Chalmers' 3-throw High-speed Pump.

the use of multiple disc or poppet valves having a restricted lift; the frictional resistance opposed to the plunger is therefore correspondingly reduced. The very compact and self-contained design of these pumps is most striking, the actual overall length being only 11 feet 8 inches by 8 feet 6 inches. Direct connection

to the motor is, of course, the ideal drive, besides the advantage gained in the saving of space, and apart from any other consideration must result in an increased mechanical efficiency of at least 5 per cent. It will be noted that the cranks and connecting-rods are totally enclosed with planished steel coverings Q, provided with examination doors X, and that there is a complete system of forced lubrication throughout, consisting of the oil tank K, chain-driven force pump L, and service pipes O. Other points of interest are the by-pass valves F for use at starting, air-chamber water gauges W, and pressure gauges U,

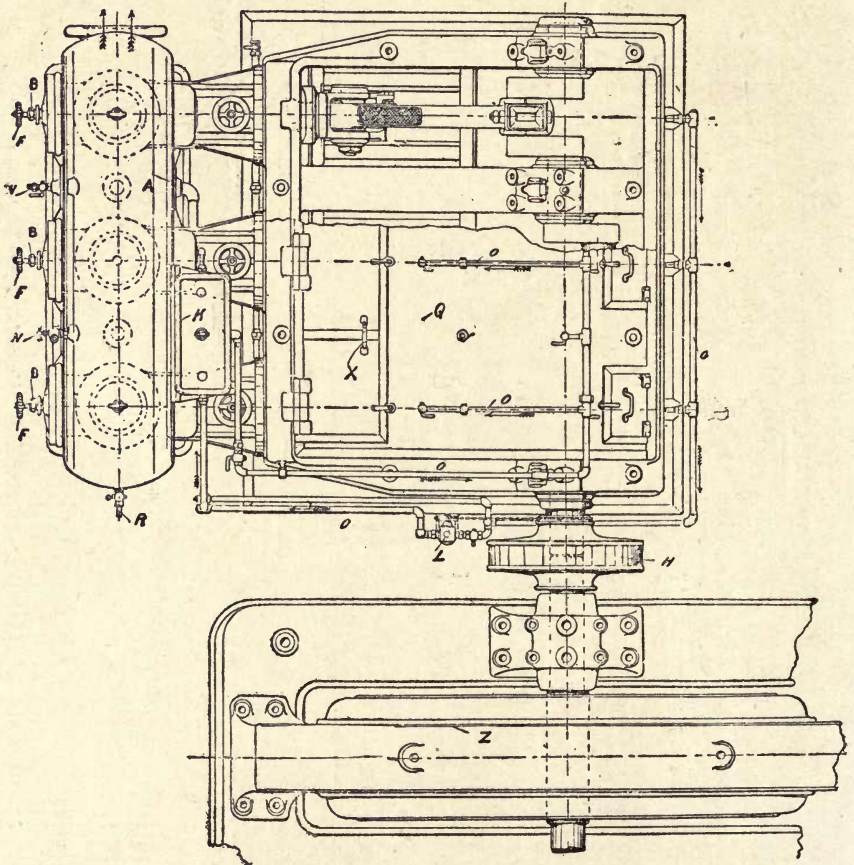

Fig. 217.—Plan of Fraser and Chalmers' Electrically-driven Dirt-tet-coupled High-speed Pump

compressed air being supplied at R from a 2-stage independent electrically driven compressor at 350 lbs. per square inch.

These pumps, it may incidentally be stated, are destined for colliery use and will be located right down to the water level, and although the water supply main S is nearly $1\frac{1}{3}$ times the combined areas of the three plungers, air chambers N are provided to further minimise any displacement loss at the high rate of speed to be run. The delivery main also exceeds in area that of the three plungers combined, no point being overlooked to risk loss of efficiency from any cause;

and as electric energy equal to 275 E.H.P. only, is being provided for each pump to overcome a gravitation resistance of 227 W.H.P., it must be allowed, providing the high efficiency of 90 per cent. is not quite realised, that there will not be a wide margin to draw upon.

Gas-power pumping engines of the direct-connected plunger type have not so far received due consideration, although for large powers there cannot be adduced any insuperable reason against the more general use of such engines for purposes where continuous and economical running are required; as this power has already been very successfully applied to blowing engines of the direct-connected type, a purpose bearing some similitude to that of pumping in that both are suited better for comparatively low piston speeds. It has, moreover, been established that pumps, both single- and double-acting, can be constructed to be run with advantage at speeds as high as from 400 to 500 feet per minute, for direct coupling to gas and oil engines, to electric motors, and as direct-connected steam pumping engines in mines and other situations where considerations of space are of prime importance.

In the case of most waterworks engines, economy in fuel consumption takes precedence over other advantages—*e.g.*, the large number of high-class 3-crank vertical engines in use in which steam expansion is carried to an extreme degree—and to such mechanical efficiency that a pump or pressure head horse-power is commonly obtained on a consumption of 11 to 12 lbs. of steam—*i.e.*, equivalent to 1.25 lbs. of coal at an evaporation of 10 lbs., which probably represents the limit in economy obtainable from steam, but not so with gas power, in which a fuel economy from 25 to 30 per cent. is now a matter of every-day practice. In other words, the limit of steam power on the above basis is about 180 millions per cwt., whereas with gas power, according to its present stage of development, a duty of from 210 to 220 millions of foot-lbs. per cwt. is possible. At this stage it will be instructive to annotate the comparative overall efficiencies of steam, electric, and gas-power pumping engines under various systems.

TABLE SHOWING DUTY OF PUMPING ENGINES, AS EXPRESSED IN MILLIONS OF FOOT-LBS. PER CONSUMPTION OF 1 CWT. OF COAL.

Worcester steam displacement pump,	1
Savery combined displacement and atmosphere pumping engine,	3
Newcomen atmospheric piston engine, average of 15 engines,	7½
Duty of largest put down,	11
Watt atmospheric single-acting piston engine,	24
Duty of Watt's latest engine of this type,	30
Cornish 3-valve single-acting direct-connected beam engines,	60
Lowest of this type,	40
Highest of this type,	70
Average duty of Watt compound rotative beam engines (30 to 50 mils.),	40
Davey 3-valve compound single-acting direct-connected beam engine,	90
Modern rotative beam engine,	90
Average duty of Worthington direct-connected duplex compensated pumping engines (106 to 144 mils.),	125
Davey direct-connected simplex differential pumping engines (108 to 124 mils.),	116
Three-crank direct-connected vertical single-acting ram plunger engines (150 to 180 mils.),	165
Three-crank triple-expansion steam engine and direct-gearred pumps,	130
Ditto. and electrically-driven geared pumps,	110
Gas-power direct-connected pumping engines of 100 H.P. and upwards (200 to 220 mils.),	210
Gas-power gear-driven pumps (160 to 180 mils.),	170
Steam power and direct-coupled electrically-driven plunger pumps,	115

Gas power and electrically-driven plunger pumps,	145
Gas-power direct-displacement pump (Humphrey),	220
Compressed-air transmission from steam engine to plunger pumps,	75
Ditto. to air-displacement pumps,	90
Hydraulic transmission from steam engine to plunger pumps,	83
High-efficiency steam engine and direct-connected volute-centrifugal pumps (lowest 104, highest 124 mils.),	114
Ditto. and turbine centrifugal pumps (lowest 123, highest 140 mils.),	132
Steam-electric-volute pump (82 to 95 mils.),	89
Steam-electric turbine pumps (100 to 112 mils.),	106
Gas-power direct-connected volute pumps (highest),	155
Ditto. turbine pumps (highest),	175
Direct-connected rotary pumps for low-lifts and steam-driven (highest),	120
Ditto. gas-driven,	160
General service steam plunger pumps,	20-60
Pulsometer pumps,	8-12
Steam jet pumps,	3-6

The sectional illustration (Fig. 218) exemplifies the application of a twin tandem double-acting 4-cycle producer-gas engine directly connected by diagonal rods (*g*) from the engine crosshead (*h*) to those of a pair double-acting plunger pumps, to raise 250,000 gallons per hour against a head of 750 feet at 110 revolutions per minute; the diameter of the four double-acting gas-power cylinders is 27 inches, and that of the pump plungers 11 inches, with a common stroke of 30 inches, and results in a plunger speed of 550 feet per minute. The two engines are arranged to work duplex fashion with outside cranks at 90°, and one central flywheel 18 feet 9 inches diameter by 15 inches wide across the rim. The extreme length of the engine is 72 feet, and the width 19 feet 6 inches; the pumps themselves, however, apart from the engine, only occupy 12 feet of this length, and are bolted direct to two double-ended crank frames of massive design, which are extended at both ends to provide guide motion bars for the crossheads. The explosion cylinders are cast in two halves at (*x*), each end being cast with a double valve pocket on the side next the flywheel, together with an outer jacket surrounding part of its length; the gap thus provided allows for the two cylinder halves to be jointed together, and also for any difference in expansion occurring along the inner and outer walls. The hollow pistons are connected by hollow rods to slipper guides at each end, and through these water is circulated under pressure. A feature of the cylinder design is the arrangement adopted for the piston-rod gland boxes, each of these fulfilling the function of a cylinder cover, and can be unbolted and slid back, thus permitting access to the cylinder bore, pistons, and valve pockets without interfering with any gear or structural arrangement of the engine.

In regard to the pump end, it will be noted that separate valve chambers are bolted together at the centre, somewhat after the manner adopted for the power cylinders, each of these chambers being bolted down to a tank bed forming a suction chamber, and provided with a series of 40 suction and discharge valves (*s s*) and (*d d*), 4 inches diameter, which, with a lift of $\frac{3}{8}$ inch, afford a waterway opening equal to approximately twice the area of the plunger. Each series of valves is carried by a floor of spherical form, and are of the rubber disc brass-backed type before described. The discharge valves of each pump are surmounted by air chambers (*a a*) of unusual capacity, and the outlet pipe for each pump is connected up to one common main, 16 inches diameter, thus equalling an area 2.1 times greater than the plungers, which are, as usual with pumps of this class, carried by detachable sleeve liners of bronze alloy.

The velocity of flow in the delivery main with the pumps running at their

full capacity of over 4,000 gallons per minute is nearly 5 feet per second, and the power represented by the plunger displacement multiplied into the pressure head approximately 1,000 W.H.P. The engines, however, are proportioned to develop this power with an efficiency of 80 per cent. at three-quarter load, and, therefore, should be capable of effecting a saving in fuel consumption over the best steam engine practice equal to quite 2 tons per day. Among other advantages of gas power must be included the possibility of stand-by pumping engines being started up with less notice, and for the plant generally to be maintained in repair with a diminished cost of upkeep.

Quite a different application of gas power is illustrated in Fig. 219, this consisting of a pair of direct-connected gas-engine driven accumulator pumps—described in *The Engineer* of Jan. 22, 1909, as being recently supplied to an iron works in Germany. In this example—and there are but few to select from up to the present—a two-cycle double-acting Siegen-Koerting gas engine and pair of single-acting ram plunger pumps are used, which pumps are capable of delivering from 25 to 90 cubic feet of pressure water at 375 lbs. per square inch per minute, when running between speeds which may be varied from 30 to 115 revolutions per minute. The diameter of the engine cylinder is 17 inches, and that of the

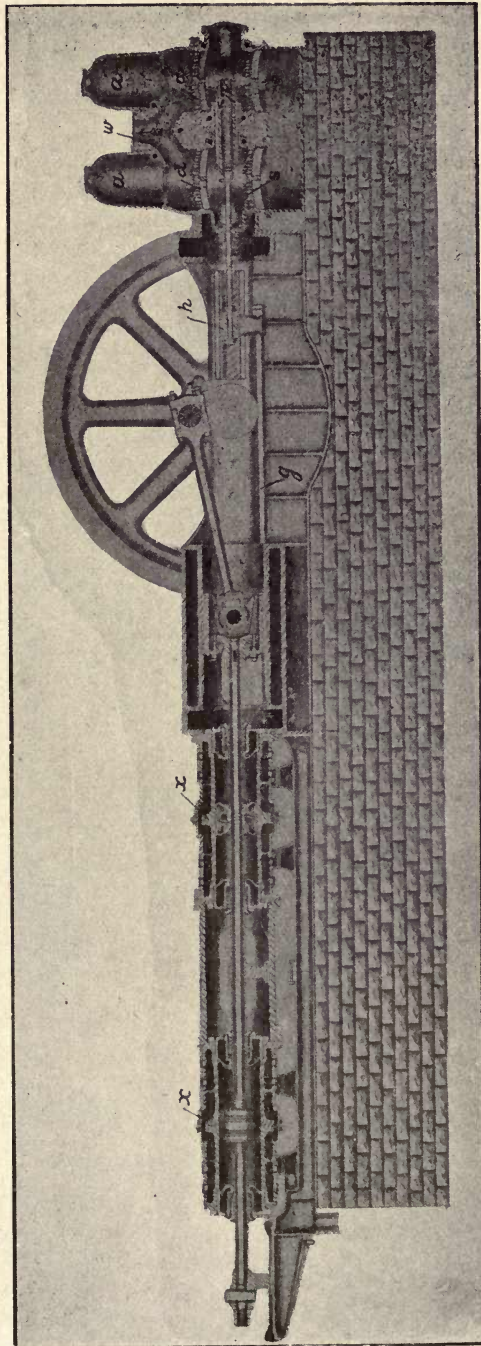

Fig. 218.—Sectional Elevation of Gas Power Water-Works Pumping Engine, designed by The Snow Steam Pump Works, U.S.A., to raise 250,000 gallons per hour against a pressure head of 750 feet.

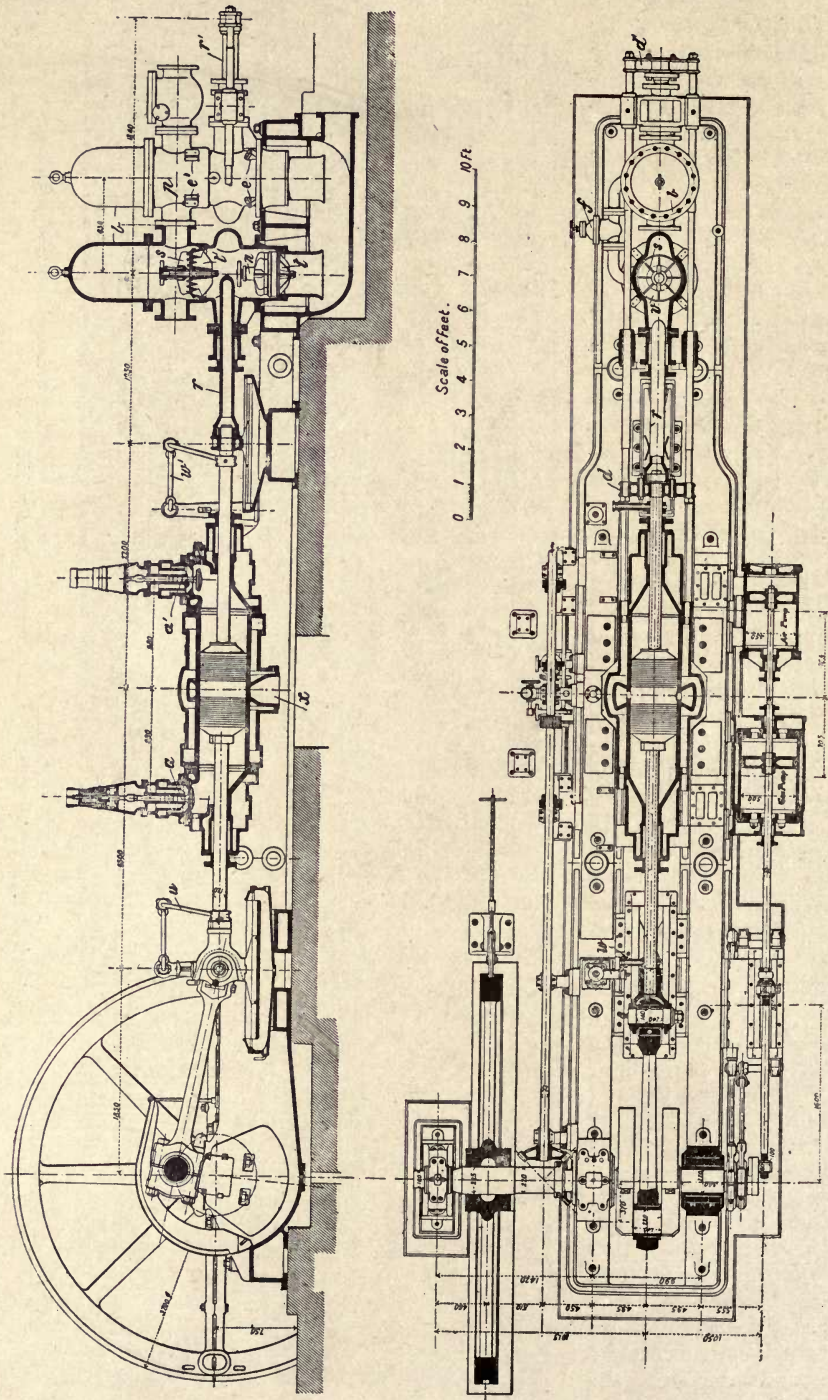

Fig. 219.—Gas-Engine Driven Direct-Connected Accumulator Pumps. (Capacity, 25 to 90 cubic feet per minute against a pressure of 375 lbs. per square inch.)

plungers, 5 inches with a common stroke of 28 inches; thus the plunger speed will have a minimum of about 140 feet, and a maximum of 540 feet per minute. In the construction of the water-end—which more particularly concerns the purpose of this treatise—cast steel is used for the rams (*r*), crossheads (*d*), and casings (*p*), and phosphor-bronze for the valves and seats.

The valves (*v*) are proportioned to afford an unusually large water-way capacity with a limited lift—*i.e.*, from two to three times the plunger area—and consist each of a series of three wedge-section leather-backed rings, held in place by a guide (*s*) and a rubber buffer (*n*). The seatings (*t*) are secured by pins let through the casing from the outside at (*e*, *e'*), which method ensures ease in dismantling, owing to there being no bolt threads in contact with water. The engine is started by air at 170 lbs. pressure (a by-pass valve (*f*) meanwhile being opened from the pressure side to the suction tank), and is governed direct from the accumulator by means of a throttle on the gas supply (blast-furnace gas), and is capable of developing about 190 I.H.P. at the maximum rated speed, when the water horse-power is approximately 120. The engine, as with steam, would, however, be capable of running at twice this speed in ordinary work, and the same argument as to the comparative advantages of the direct-connected *versus* the gear-driven method applies—*i.e.*, it resolves itself into a question of a larger gear-driven set of pumps against a larger engine, which it will be gathered from the illustration is very massive for the power developed, and comprises a continuous bed some 30 feet long, and joined-up in three lengths by shrunk rings. The engine cylinder is cast in one piece with the outer jacket, and provided with cam-operated admission valves (*a*, *a'*) and a central belt of ports leading to (*x*) for the exhaust.

Particulars of another gas-pumping plant, but of a different character, may also be included to further illustrate the advantages of gas power: This consists of two 4-cycle single-cylinder Fielding & Platt gas engines—16½ by 22 inches—and two triple-action Hatfield pumps, 9 by 6 inches stroke, put down at a water station in New Zealand. The capacity of each of these sets is 750 gallons per minute—*i.e.*, 45,000 gallons per hour—against a head of 120 feet plus 10 feet of suction lift; and convertible to delivering 400 gallons per minute against a head of 200 feet plus 10 feet of suction lift, the reservoir being 1,400 feet distant from the pumping station, and the delivery main 10 inches diameter, with a velocity of flow equal to 3.8 feet per second.

A half-plan general arrangement of this plant is illustrated by Fig. 220, and is interesting in that the pumps are coupled up so as to be driven at their higher capacity at the same speed as the engines—*i.e.*, 180 revolutions per minute—the original intention having been to couple them up direct at the higher speed, and to run them through a reducing gear at the lower speed. The arrangement adopted will be recognised as resembling the speed gear used in automobile practice, and dispenses with a side shaft. Referring to the plan view, the engines, which are of the horizontal type, are fitted with double fly-wheels, 6 feet 4½ inches diameter, carried by 5½ inches diameter crank shafts provided with friction couplings K, having expanding segments operated by the hand-wheel shown. The pumps P are each of the type illustrated by Figs. 199 and 200, and are driven from the engine shaft extension carrying a pair of sliding spur-wheels, arranged to engage with wheel H for delivering to the low-level reservoir, and with wheel L for the reduced speed necessary for the high-level reservoir. The pumps are provided with three suction and three discharge valves for each plunger, these being located in semicircle formation at the out end of each barrel, and readily accessible on removing the end covers. The

pump barrels are lined and the plungers cast in bronze alloy, and have rod extensions at the water ends working in guide sockets, the length of the plungers in this manner being shortened. The air bell is shown at N, below which is a valve-regulated by-pass between the suction and discharge pipes S and D.

Both engines G are arranged for being started up on town gas, and a blower B provided for supplying air to the producers until gas of the right quality

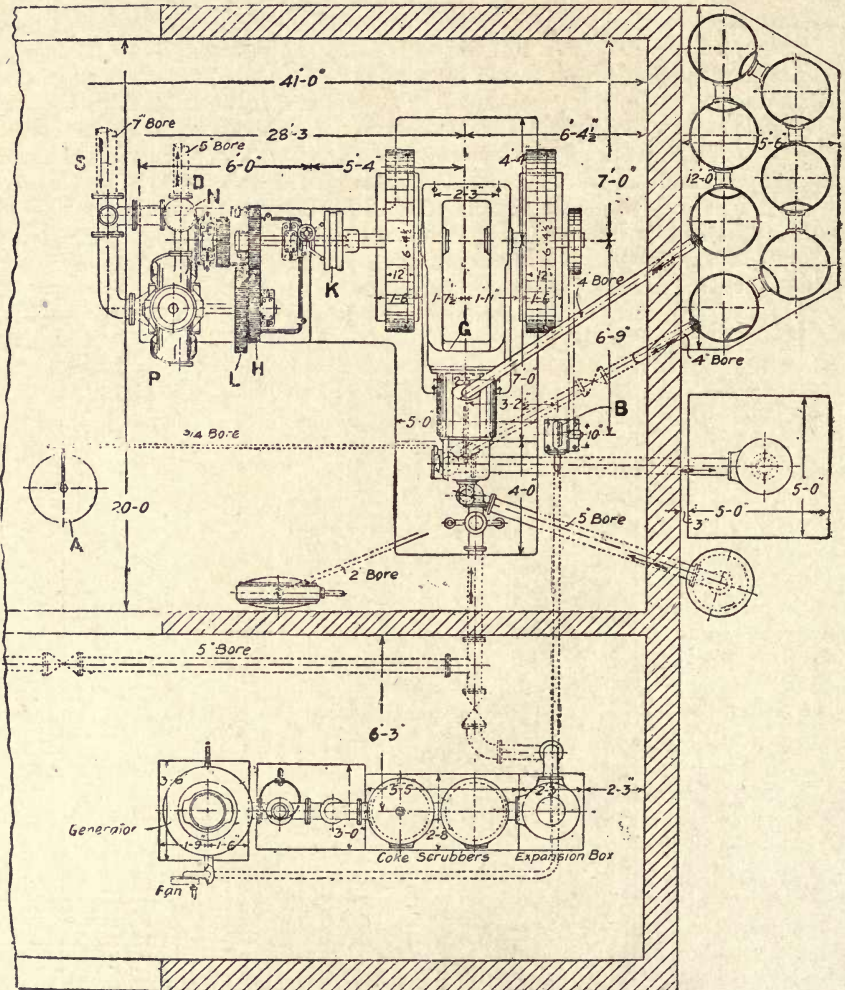

Fig. 220.—Half-plan Arrangement of Gas-power Pumping Plant.

is generated; the engines can then be immediately switched on to producer gas, after which their action is continued by suction effect. There are two producer sets, consisting of generator, gas cleaners, etc., in a room 41 by 11 feet, at the rear of the engine and pump room, 41 by 20 feet wide, the gas piping being arranged so that either engine can be supplied from either producer set. The engines are arranged to be started by compressed air at about 80 lbs. pressure

stored in the reservoir A, which is charged by an independent gas motor, the starting up of either set of pumps by this means only occupying a few minutes on town gas. In regard to power, the engines are rather in excess of present requirements, the power indicated in one set of pumps when allowing for the full pressure head and line resistance not exceeding 40 H.P., whereas either engine is easily capable of developing 60 B.H.P. on either anthracite coal or gas coke. However, as the pumps are well adapted for a larger output, an opportunity may present itself some day for meeting an increased demand on the water supply, in which event a slight alteration in the gearing will be the only requirement necessary for speeding the pumps up to a higher ratio.

Besides direct-connected gas-driven pumps, as per the examples above described, and which are more suitable for the larger powers, there are a vast and increasing number of oil- and gas-power pumping plants, arranged either as belt-driven, gear-driven, or as direct-coupled units for town supply, drainage, and other work: consisting for the most part either of producer-gas engines of the single-cylinder horizontal type; or single, or double-cylinder fuel-oil engines (mostly vertical) of the high-compression (Diesel) type; not to mention the numerous town-gas and kerozene-oil driven pumps of smaller capacity.

CHAPTER XVI.

VARIABLE DELIVERY PUMPS AND VARIABLE TRANSMISSION
BY HYDRAULIC POWER.

In the treatment of this subject only pumps of the positive-acting plunger type will be considered, although other types are capable of delivering a variable discharge at constant speed, but do not conform to the pressure requirements demanded in connection with hydraulic transmission of power; charging accumulators for operating lifts, presses, and the like, and for use under those other circumstances wherewith a pressure flow is required at a definite pressure and volume. Plunger pumps best fulfil these requirements, and are most usefully employed where a variable delivery is a *sine quâ non* at constant speeds, as, for instance, when required to be driven from works shaft lines, from gas or oil engines, electric motors, and in all such cases where it is expedient for the pump duty to be varied independently of the drive. By means of suitably designed pumps of this class, not only are fast and loose pulleys, friction clutches, speed gearing, and switch controllers dispensed with, thus resulting in a simplified installation, but the additional advantage is obtained of an enhanced power efficiency—especially is this the case where, from motives of economy or otherwise, it is inexpedient to provide for the necessary volume of discharge either by varying the speed of the motor, or by the use of a variable transmission gear.

Apropos to this, many variable gears have been introduced from time to time in connection more especially with electrically-driven pumps, in all of which the primary claim is for the purpose of eliminating the loss of current inseparable with the method of speed control obtained by switching into circuit a resistance varying with the requirements of the pump—a method that has been found to be most wasteful with any combination of wiring in a single motor; however, this drawback to a great extent disappears with the use of two motors, thus permitting parallel as well as series working to be obtained when utilising a continuous current as the source of power after the manner more generally adopted in electric traction.

The actual necessity for the construction of a variable-delivery pump capable of a high efficiency has been probably more keenly realised in the various attempts to transmit hydraulically power from gas and oil engines to the propulsion of tramcars and automobiles than from any other cause, this purpose demanding a full range of pressure delivery from the pump to the motor cylinders, which shall be capable of working with an overall efficiency not falling far below 60 per cent. in order to be able to compete favourably with various constructions of gear transmissions.

Representative examples of the most practicable schemes resulting from these and other efforts are illustrated by Fig. 221. In the inception of a suitable mechanism for obtaining a variable delivery, in all probability the first method that would present itself to the average engineer is a suitable adaptation

of the link motion, as used in reversible steam engines. Two examples of this kind are shown at (a) and (b), Fig. 221. In the first of these a crank N is connected to a rocking open link K, from which motion is communicated to the pump plunger by the rod T held in position by the lever L, the capacity of a

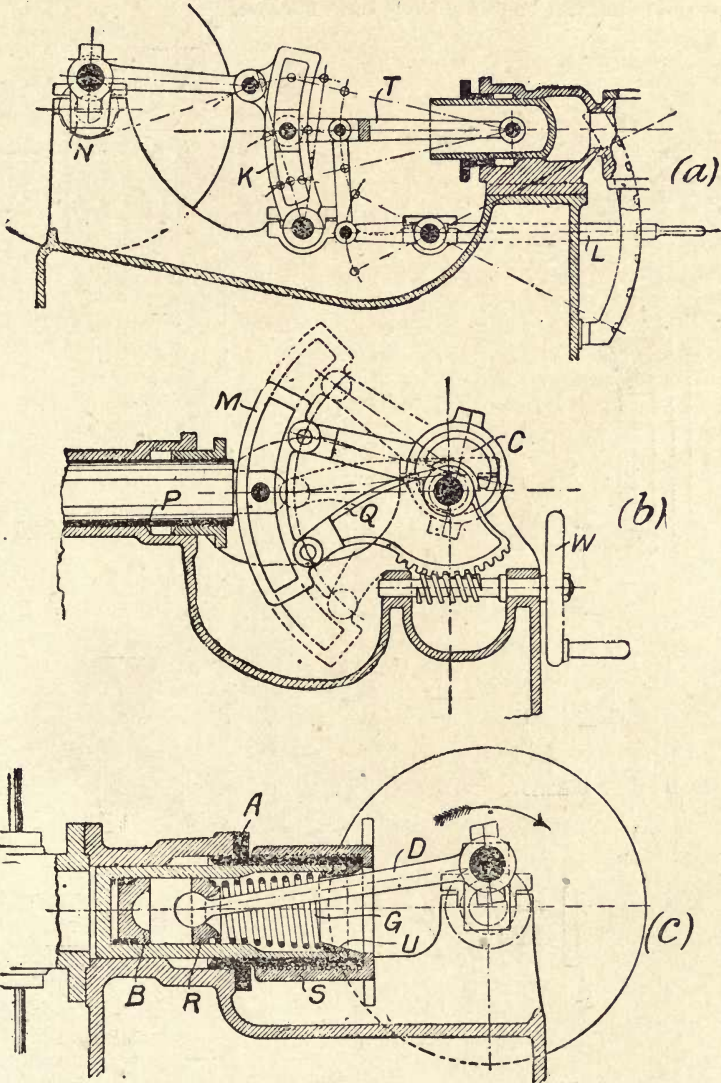

Fig. 221.—Pump Arrangements, showing Link and Lost Motion Methods for obtaining Variable Delivery at Constant Speeds

pump driven in this manner being capable of a variation over a range from full stroke down to about one-fourth. In the second example (b) a full range

is possible, one end of the open link M being connected to the rod actuated by the eccentric C, and the other end to a rod pivoted from the driving shaft bearing, this rod being conveniently constructed to form part of a quadrant Q arranged to be held in the desired position by the wheel W; in this design it will be noted that the thrust on the plunger P is always in a straight line, and that the pump can be put entirely out of action.

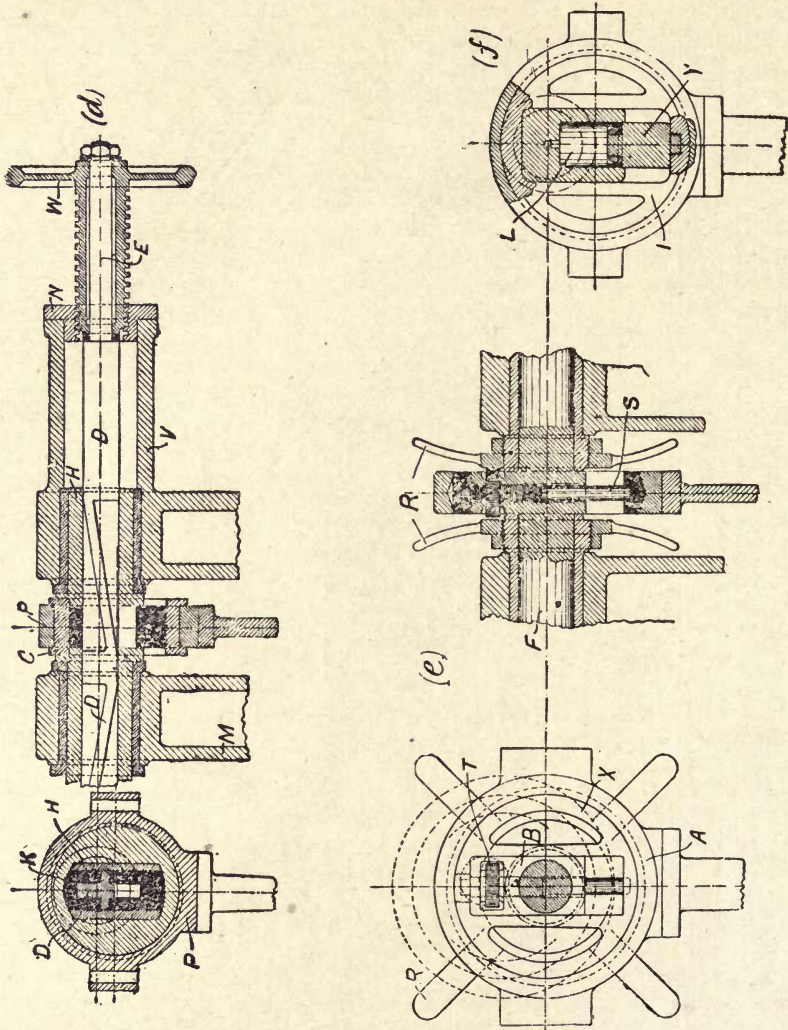

Fig. 222.—Examples of Variable-throw Eccentrics.

The example (e) illustrates one construction of a mechanism sometimes used in automobile practice to vary the stroke of the boiler-feed pump, for which purpose a small solid plunger is provided with a spring, as at G, which is located between a bearing R pressing on the rod D, a collar U, and an adjustable stop as at S, this stop being conveniently arranged to screw over an extension of the gland A; the bottom half of the bearing B is separated from the plunger by

a buffer spring to absorb shock on the engagement of the rod end with the thrust block. In this example the plunger will always complete its in stroke by the ram action of the rod D, while the out stroke is determined by the position of S, the compression of the spring taking up the balance of the movement of R.

In Fig. 222 are shown some three examples of variable-throw single eccentrics, each of which is capable of adjustment while in motion, the eccentric sheave in each of these variable-throw gears is slotted to fit over a block forming part of the shaft, while the movement to and from the centre of the shaft is either effected on the principle of the inclined plane, the screw, or by hydraulic means. In the example (*d*) a rather ingenious arrangement, known as Newman's variable-stroke gear, is shown, which is adaptable to a pump having either one, two, or three plungers; these are actuated by eccentrics C, which are locked in the required position on the driving shaft H by a rod D formed with wedge sections, and to slide within blocks K, which in turn are carried by slotted webs or blocks formed on the bored-out driving shaft. The throw of each eccentric C is determined by the lateral movement of the rod D caused by the movement of the screw W within the nut N; and within this screw the extension E of the rod D is free to rotate. By the hand-wheel W the wedge formation on D for each eccentric can thus be adjusted while the shaft is in motion, the respective angles of the eccentrics in a 3-throw pump being 120° , as in ordinary practice. In the illustration the eccentric C is shown at full stroke, the rod being held outwards in the arm V to its full extent; it will be noted also that the squared portions on the driving shaft carrying the eccentric sheaves are slotted each to receive a wedge block K, by which means the stroke of each of the eccentrics in a multiple-throw pump can be equally and simultaneously varied in either direction, the exact length of the stroke being self-recording by the addition of an indexed dial or plate.

The arrangement as shown at (*e*) is more suitable for a single-throw pump. In this example an eccentric X is carried by a web B forming part of the driving shaft F, as in (*d*), but in this gear a screw S with a nut T is used to traverse X across B. In order to obtain any desired adjustment while in motion, two discs R are used, each of which is carried by a screwed extension of the shaft bearings, and can be rotated by hand so as to press against either side of the nut T, according as the stroke of A is to be made longer or shorter. In another modification (Piers), shown at (*f*), an eccentric I is traversed by a plunger Y moving in a barrel formation of the sheave guide block L by oil pressure supplied through a small hole drilled in the shaft, and communicating either with a hand pump or other suitable pressure supply, as, for instance, with the oil pressure used in circulation from pump to motor in a road car transmission scheme.

Many combinations have been devised in order to be able to obtain a variable throw both for pump plungers and for water motor pistons, among which may be included descriptions of a few representative types of variable-delivery pumps in which are employed either one of several arrangements of compound eccentrics, cranks, or plungers, such as represented by the examples shown in Fig. 223; or an entirely different construction may be used, having radial revolving cylinders or barrels with pistons or plungers connected to a fixed crank, the adjustment of which presents a convenient means for varying the stroke in either direction while in action, the example illustrating this principle, Fig. 223 being designed as a variable-delivery pump.

Proceeding to describe the various devices referred to in the order named, we find an inner sheave combined with an outer sheave in the compound eccentric

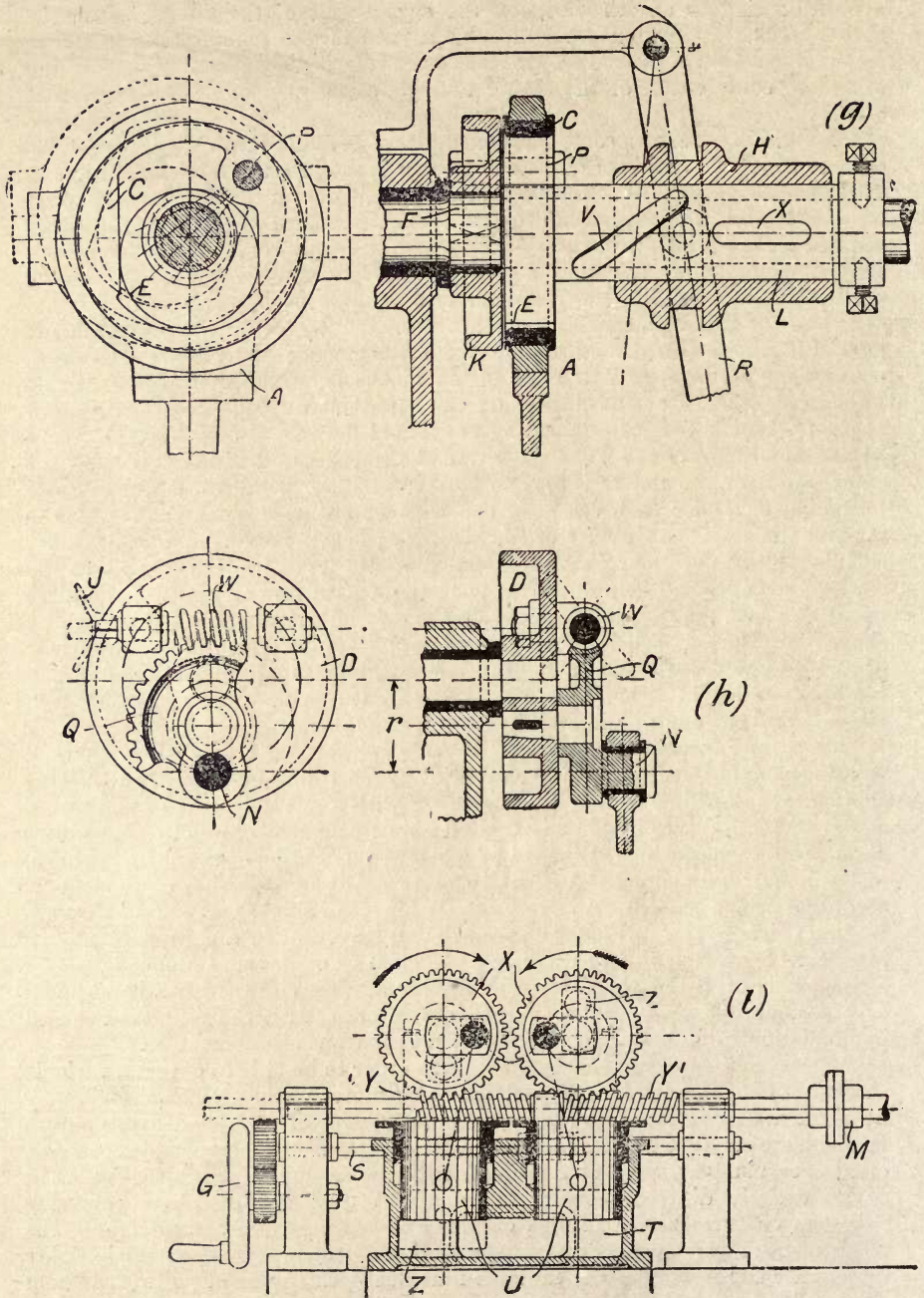

Fig. 223.—Examples of Compound Eccentric, Crank, and Plunger Mechanisms for obtaining Variable Delivery at Constant Speeds.

mechanism shown at (*g*), Fig. 223. In this example an eccentric C is pivoted to a disc K at P; within C is an opening with two parallel sides bearing against which is a second eccentric E; obviously by the partial rotation of E, the eccentric C can be moved to or from the centre of F, as shown in dotted lines. The position of E relatively to F may also be determined by gear pinions, or more conveniently by an adaptation of the archimedean screw principle, by which the necessary rotation of C on P may be effected by sliding a sleeve or coupling nut H over an extension of E and a fixed collar or sheave L, either of which is provided with an inclined groove or key V. In the illustration an inclined key V is inserted in an extension of the inner sheave E, and a parallel key X in the collar or sheave L, corresponding ways being cut in the coupling sleeve or nut H, thus by a lateral movement of the nut by a hand-wheel or lever R, the throw of the eccentric strap A may be varied. The objection to all compound eccentric variable-throw gears is the large diameter of the outer sheave, and in this particular arrangement the additional unadaptability for use with multiple-throw pumps.

The compound crank and plunger mechanisms shown at (*h*) and (*i*), Fig. 223, have been designed by Mr. W. L. Spence, to afford a variable delivery in pumps working with a length of stroke incompatible with the use of eccentrics, the action of both of which are sufficiently clear without much description. In the compound variable-throw crank mechanism (*h*) a disc D carries a quadrant Q having a crank pin N, and arranged to mesh with a worm W, by which means the stroke (r) may be reduced to zero if required, although in the illustration the quadrant teeth only allow a reduction of 75 per cent. By means of a star wheel J and a striker not shown, the worm W can be rotated while the pump is in motion. In the diagrammatic arrangement (*i*) two plungers U are actuated from separate crank shafts placed parallel to one another, and provided with gear wheels X, which mesh with worms Y and Y', having threads at opposite angles. By a lateral movement of the worm shaft from right to left, the relative positions of the two cranks and plungers can be changed from coincident to opposite, as shown in dotted lines at Z, when the action of one plunger will neutralise the other, both barrels communicating with one common pump chamber T. The discharge from the pump when working in the position shown will be equal to the combined displacement of both plungers, any intermediate rate of delivery from this down to zero being controllable while in action by the wheel G and screw shaft S; the driving shaft M can be conveniently coupled to an electric, gas, or other drive.

The radial barrel rotative variable-delivery pump illustrated by Fig. 224 demonstrates the principle involved in all pumps or motors of this type. In this example only three barrels are arranged at equal intervals about a crank chamber capable of revolving on trunnion bearings, although four or even six are sometimes used. The principal feature in them all is the fixed crank as at K; this in this instance forms part of a hollow intake for water from S to the crank chamber R, whence it passes through the plungers P into the barrels B, B¹, B² in succession, it being delivered through the valves V, the passages A, and trunnions N, to the delivery outlet at D. The bearings T, which are each necessarily provided with trunnion glands, carry on one side a fixed sleeve E, bored eccentrically to receive the hollow crank shaft K; the eccentricity of this sleeve E is equal to the radius of the crank K on its shaft, so that on rotating the crank shaft in the fixed sleeve E as by the worm gearing H W for a half of a revolution of K, the crank centre will coincide with the centre of the revolving barrels, and result in reducing the stroke of the plungers to zero; the crank in

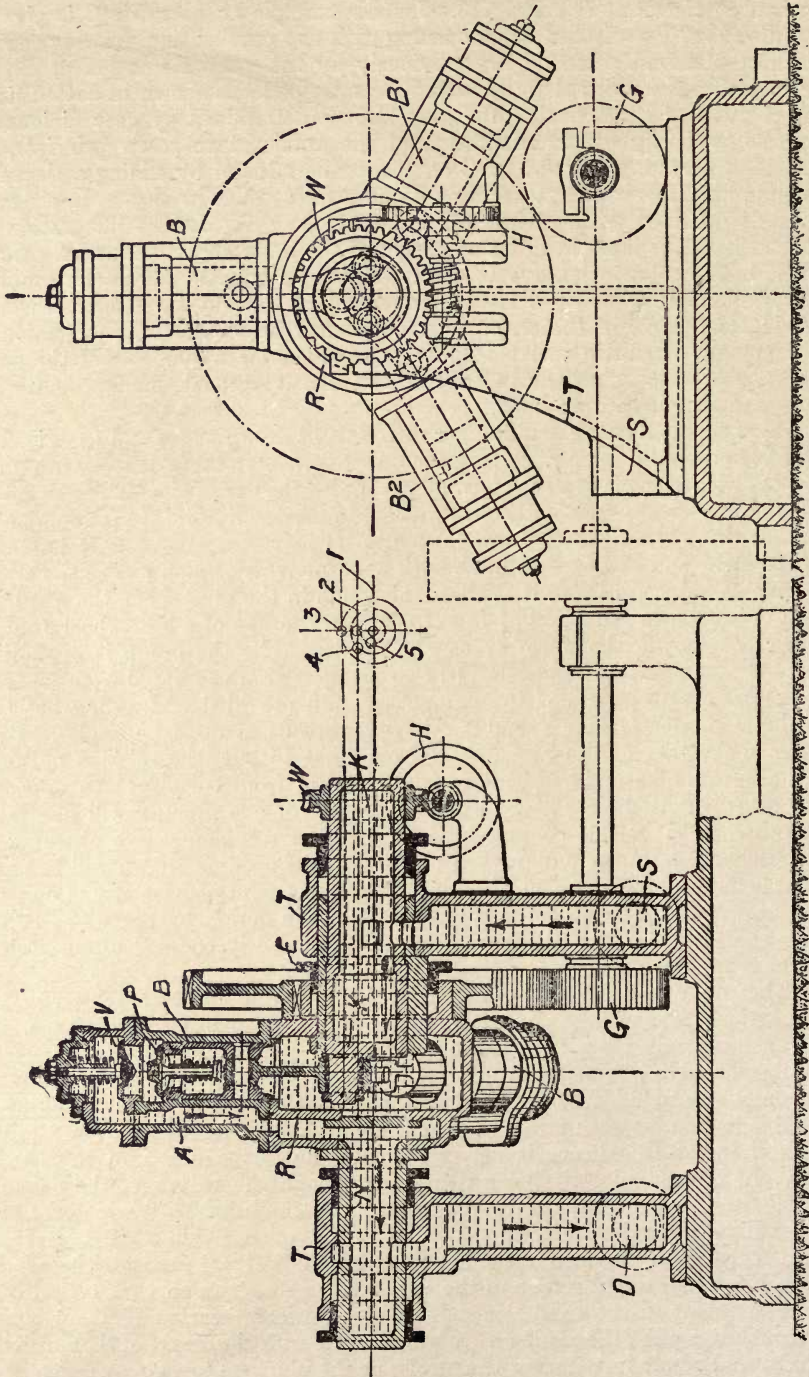

Fig. 224. —Treble-barrel Variable Delivery Radial Pump.

the position shown is at its greatest distance from the pump centre. This action is also shown diagrammatically, the eccentricity of the bore of the sleeve E to its outer diameter being indicated by the distance between the centre lines 1 and 2, which dimension is equal to the radius of the crank—i.e., from the line 2 to centre 3—from which it follows that on rotating the fixed crank trunnion K about the centre line 2, the distance of the crank pin K from the centre of rotation of the pump barrels—i.e., the centre line 1—can be adjusted to produce any required stroke reduction from maximum to zero, or *vice versa*, one-sixth of a turn resulting in the movement of the fixed crank centre from 3 to 4, and one-third of a turn to position 5, and a half-revolution of K will throw the pump entirely out of action.

In pumps of the radial type the crank shaft or trunnion K may be substituted by an eccentric sheave usually forged in one piece, with the shaft communicating with the controlling gear as at H W; also the separate inlet and outlet lift valves may be substituted either by a piston valve for each plunger or by one combined inlet and outlet rotary valve, as used in the Brotherhood and Rigg hydraulic engines, from which portways communicate with each cylinder, the additional length of the waterways having but little effect, provided their area be proportionate to the speed required. Motors of this type with three revolving cylinders are self-starting and reversible, and are economically employed for many purposes where water pressure is available, whether from waterworks service or from hydraulic power-distributing mains.

For the economical transmission of power from a water-pressure supply, an engine constructed to work with a variable stroke is almost an unavoidable feature in order to obtain power control at constant speed, unless mean be provided for taking part of its supply from a low-pressure service (as in hydraulic-lift practice). Where power is required to be transmitted hydraulically from a pump actuated by an internal-combustion engine, or electrically for purposes wherewith the demand for power is variable and intermittent, a pump conforming to one of the characteristics above explained is the most suitable. But under those circumstances where a variable power can be transmitted from a pump running at a constant speed to a point adjacent, as, for instance, in an automobile, a very different method can be adopted, and the oil or other fluid be used in a closed circuit instead of in the manner above explained.

Variable-power transmission on the closed-circuit principle, as introduced by Mr. J. W. Hall, presents a most attractive aspect in comparison with the open system, since, instead of the flow of fluid increasing in proportion to the speed of the driven engine, as resulting from the combination of a variable-delivery pump and hydraulic transmitter, pressure-flow delivery from the pump to the engine is in inverse ratio to the speed, thus the flow which is at its highest rate when the engine is running at its lowest speed is totally arrested when the speed of the driven engine synchronises entirely with the pump. To realise in practice this important reduction in fractional resistance the pump and transmitter are combined to form one unit, in the construction of which the radial principle is adopted, the barrels and cylinders of both pump and engine revolving together about a fixed centre, with which a crank shaft for communicating motion to the pump plungers is coupled up with an oil or petrol motor arranged coaxially, the pump barrels being connected to the transmitter engine cylinders through distributing valves, and the pistons to a fixed crank capable of adjustment in the manner made plain by Fig. 224. According to this combination the speed of rotation communicated to the gear will depend on the relative volumetric capacities of the pump and engine, the gear revolving

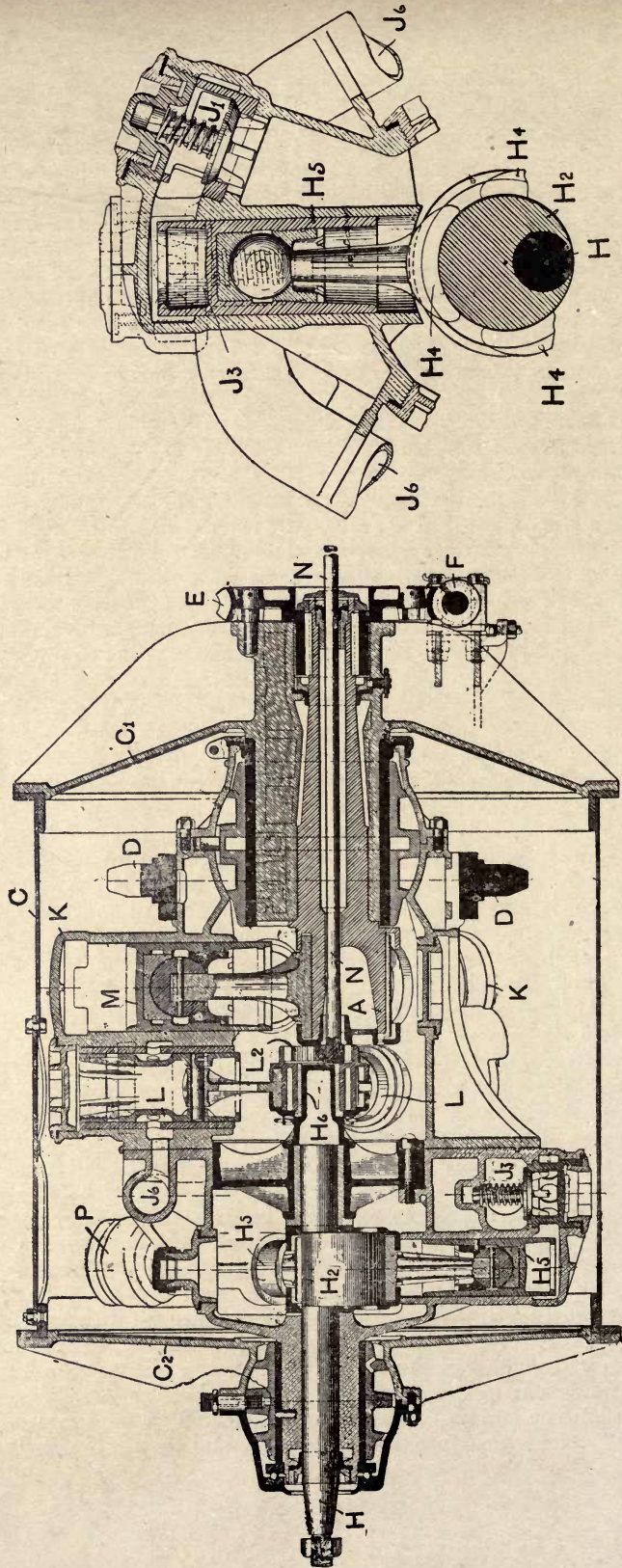

Fig 225.—Sectional Elevation showing Radial Pump and Variable Stroke Engine in the Hall Hydraulic Automobile Transmission Gear.

at its slowest when the stroke of the engine pistons is at their maximum, and will be locked entirely so as to rotate in synchronism with the pump crank shaft when the stroke of the transmitter is reduced to zero.

In the example, Fig. 225, illustrating one construction of the Hall * transmission gear made for a 2-ton motor lorry, a treble-barrel radial pump P, having plungers H⁵, each 2 $\frac{3}{16}$ inches diameter, and connected by rods H⁴ to an eccentric sheave H² forged solid with the power shaft H (by which means the plungers H⁵ receive a fixed stroke of 1 $\frac{3}{4}$ inches), is combined with a 3-cylinder radial engine K, having pistons M 3 $\frac{5}{16}$ inches diameter connected to a fixed crank A, capable of an adjustment to impart a stroke varying from zero to a maximum of 2 $\frac{1}{4}$ inches. Both pump and engine are bolted together, and revolve at speeds varying from that of the power shaft H (as when the crank A is moved round by the worm and wheel F E to coincide with the axis of P and K) down to a speed reduction of 5 (the relative volumetric capacities of P and K, with A at maximum radius being as 1 to 4) in trunnion bearings carried by the covers C¹ and C² of the casing C. In this particular design steel lift valves are used for the pump (the main castings being in hard bronze); oil from the crank case enters P at J¹, and exits at J³ to the passage J⁶, whence it is distributed to the cylinders K by the piston valves L (2 $\frac{5}{8}$ inches diameter), receiving their motion from an eccentric revolving about an arm H⁶ carried by the crank case of P and K; the position of this sheave can be changed circumferentially by the toothed ring L² and pinion on spindle N to give either a forward or reverse direction to P and K, and thence to the driving wheels of the car from the sprocket D. No packing rings are found necessary for either of the pistons H⁵, M, or L, all of which are in steel, and show very little trace of wear after years' use.

Speed of Electric Motor.	Speed of Transmission.	Speed Ratio.	Motor B.H.P.	Gear B.H.P.	Gear Efficiency.
308	42	7.2	5.05	3.64	72.1
314	66	4.76	4.83	3.56	73.7
316	130	2.43	5.0	3.72	74.4
316	228	1.39	5.0	3.95	79.0
428	64	6.7	5.24	4.18	79.7
430	132	3.26	5.4	4.4	81.5
440	337	1.31	5.29	4.04	76.4
326	105	3.1	0.945	0.	..
328	270	1.21	1.36	0.	..
448	72	6.22	1.26	0.	..
444	205	2.17	1.9	0.	..

The action of this transmission is such that if A is adjusted by F, so as to result in no displacement in K by M, the plungers H⁵ will be locked, and in consequence will force P and K to revolve at the speed of H, the transmission then being gearless,—viz., there will be no movement of either plunger or piston nor circulation of oil. *Per contra*, as the engine crank A is moved away from the axis of P and K, so will follow a displacement in K, until with A adjusted for full stroke the relative displacement per revolution will be as the difference between P and K, which in this case is as 1 to 4; thus the speed of D will be 4 + 1 times slower than H in the forward direction, and 4 - 1 times slower

* The Auto-Motor Journal.

for the reverse, this discrepancy can, however, be modified by increasing the ratio of K to P. The range of speed in the lorry fitted with a gear on this ratio is with a 12 B.H.P. 2-cylinder petrol motor from 2 to 10 miles per hour without changing the speed of the motor; this transmission makes it possible also to dispense with both clutch and reversing gear. In regard to efficiency, it would be reasonable to assume that with a direct drive between the motor, gear, and vehicle, that this should be high, bearing in mind that all the mechanism runs in oil and is absolutely dust-proof.

A test of a 2-ton lorry on gradients of from 1 in 16 to 1 in 9 made by Mr. Worby Beaumont proved a transmission efficiency from the motor shaft to the road of 71.8 per cent., this, however, included a chain drive from motor to gear

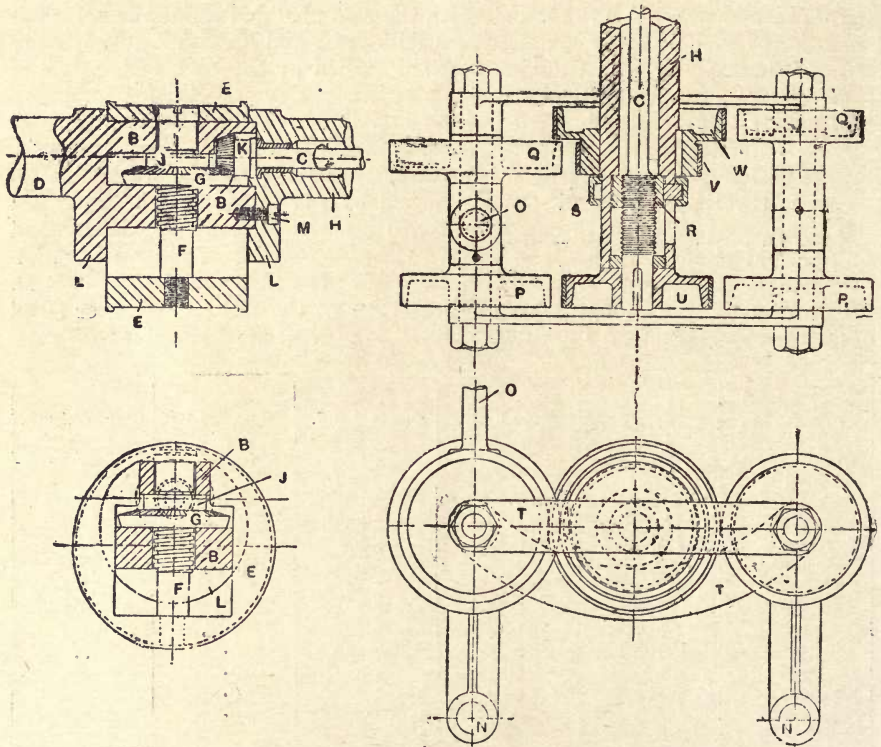

Fig. 226.—Variable Stroke Mechanism for Merryweather Fire Pump.

shaft and counterbalance gear shaft between the gear and the road wheels; but in an improved gear since designed by Mr. Hall (in which piston valves of large diameter will take the place of the spring-loaded lift valves, and which will be coupled up direct to the motor shaft), an overall efficiency between the motor and the road wheels may be expected to prove as high as from 75 to 80 per cent., according to the speed of the car, which should again be still further increased by the substitution of ball-race bearings for the sheave and crank pin. The outer casing C will also be dispensed with in the latest development of this most interesting variable-speed transmission gear, and the ratio between the pump and engine increased to 6, thus affording a wider range of speed, so

adapting its application in its simplified form to pleasure cars. It would seem in this connection from the favourable results already obtained with this gear, that the advantages of transmission on the hydraulic principle are exceptional, seeing that a positive and absolutely variable drive is obtainable over a wide range of speed and power, with an efficiency as high as can be obtained with an electric transmission and more silent and durable than with any construction of change-speed friction or cog-wheel gear yet devised.

In order to get the fullest possible output from a pump against varying pressure heads when actuated by oil, gas, or electric power, as in the case of a combined fire pump and petrol or electric motor, it is an advantage to be able to utilise the power available by employing means such as change-speed gearing or a pump capable of a variable discharge, by which means the volume of water that may be projected can be proportioned to the pressure head—*i.e.*, a pump so constructed may be readily adapted for high as well as low service. With this object in view, the Hatfield single-throw treble-barrel pumps of the kind illustrated by Fig. 200 are fitted with a variable-throw eccentric, the strap of which is connected to the three plungers. The mechanism employed for this purpose is an improvement on the method illustrated at (e), Fig. 222, as will be noted by reference to the sectional details of this gear shown at Fig. 226, the apparatus also being provided for changing and recording the length of stroke while in action.

The web block L of the driving shaft D is squared to carry with a sliding fit the sheave E, the position of which is determined by the movement of a bevel wheel G and nut J on the fixed screw F, by means of the pinion K and spindle C. The web L is constructed in two parts, which are held together by screws M, the web being slotted to form two cheeks B, between which is inserted the wheel nut J G. The out end of the shaft H is bored to receive the controlling spindle C, by the rotation of which the eccentricity of E can be adjusted from a maximum, as shown, to coincide with D. In order to vary the stroke while running, the out end of H carries two friction wheels V W, and the spindle C, a third wheel U. The relative movement of C with H can thus be either made faster or slower by pressing the friction wheels Q P against U V, in which case C will be rotated slower than H, or by pressing Q¹ P¹ against U W, in which case C will be rotated faster than H, and in this manner the position of E on D determined, the exact length of stroke being conveniently indicated by a nut R carrying a sleeve S constructed to act as an index; the two pairs of friction wheels carried by T and N are operated as desired by the lever O. It may be here mentioned that with a gear of this kind the motor can be more easily started, and the load adjusted under varying conditions to its power and speed.

The 3-throw variable-delivery Sinclair pump (Fig. 227) has been devised more especially to meet the requirements for economically-driven boiler-feed pumps in electric light and power stations, where auxiliary pumps can be more conveniently and economically run by electric power than by steam. In order to obtain better results with a motor-driven feed pump, it is essential for the output of the pump to be independent of the motor, so as to cope with the varying rates of evaporation in the boilers, without resorting to the practice of putting into or cutting out of the armature circuit resistances of varying power. The common method adopted for controlling the speed of a continuous-current motor is to divide the resistance up into a number of sections, which are connected to separate stops on a regulating switch, by which means the current is throttled or absorbed to the required degree.

By this method, which is very wasteful, the electric current passing through the motor and resistance is practically constant for any output of the motor, therefore a pump slowed down below normal would on this system use prac-

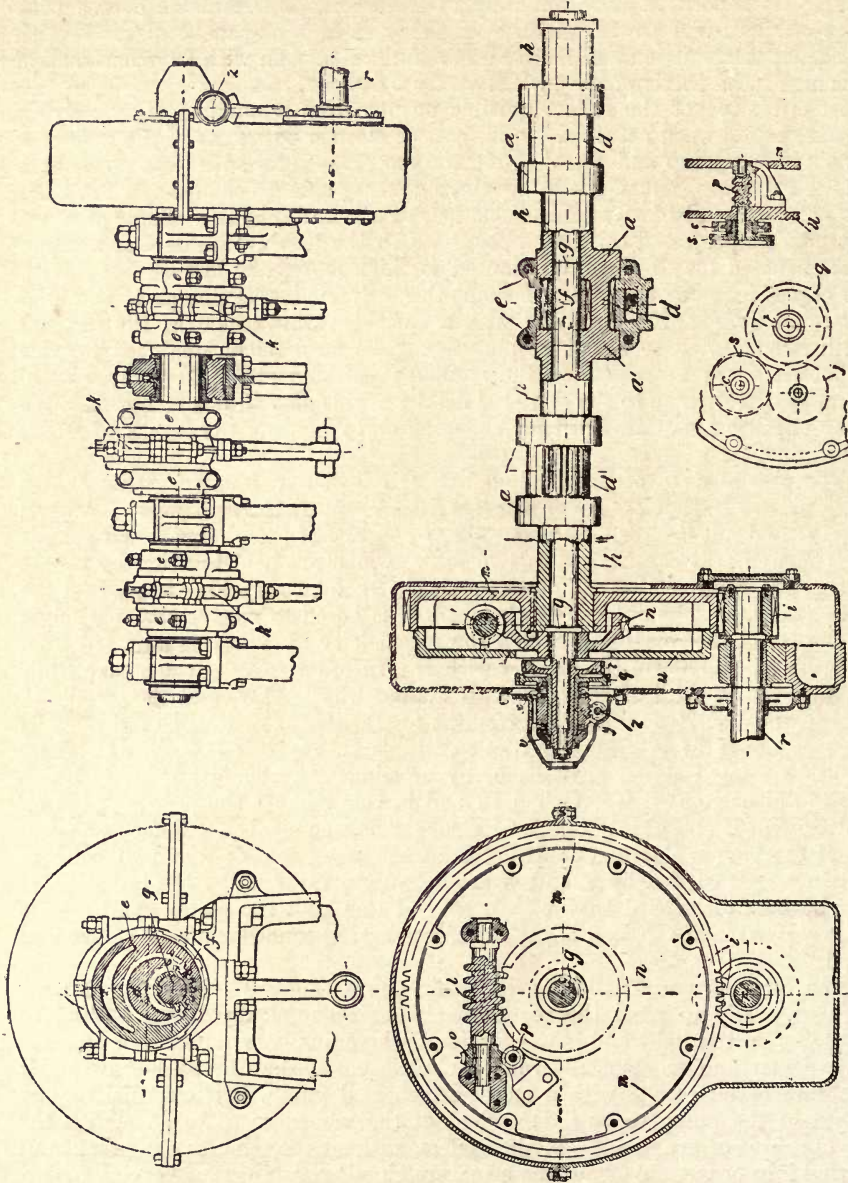

Fig. 227.—Sinclair Stroke controlling Mechanism used in Hayward-Tyler Variable Delivery Pump.

tically as much current as on full delivery. Other methods such as the use of double motors and working them in series or parallel as on trams, or the use of special compound-wound armatures, give much more economical results;

but even with these the advance in speed is not regular, and, indeed, as far as alternating-current motors are concerned, it is quite impossible to vary the

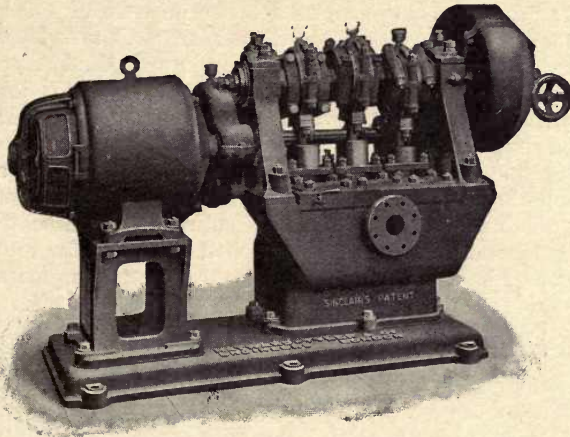

Fig. 227A.—Hayward-Tyler 5-inch by 4-inch Variable Delivery Pump, feeding Boilers at 200 Lbs. Pressure with Water 190°.

speed economically over a wide range. By employing a variable-stroke pump, as illustrated by Fig. 227, the motor and pump may be run at constant speed, and

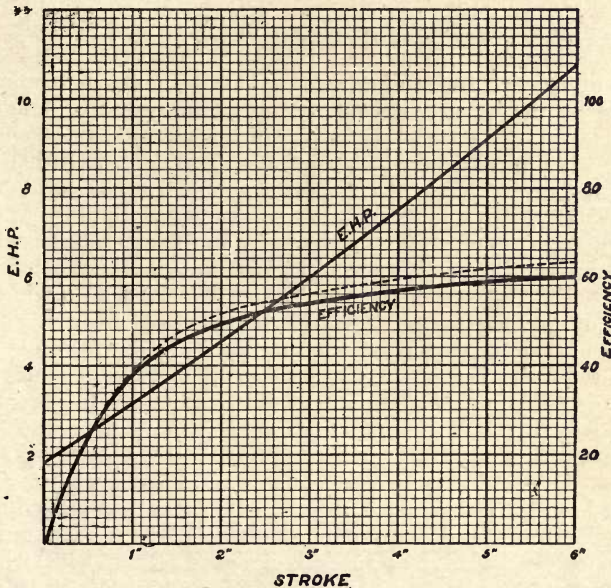

Fig. 228.—Diagram showing Results of Efficiency Test on Sinclair 3-throw 5-inch by 6-inch Electrically-driven Boiler Feed Pump.

thus obviate resistance losses, and moreover the exact rate of delivery is under perfect control. The diagram Fig. 228 shows at a glance the advantage gained

by this method of control, the full lines indicating the efficiency and electrical horse-power curves for a 5-inch diameter by 6-inch stroke 3-throw Sinclair variable-stroke pump working against a boiler pressure of 150 lbs. per square inch with a 15 B.H.P. motor, and the dotted line with a 12 B.H.P. motor. It will be noted that nearly maximum efficiency is maintained down to less than half stroke—viz., the electric horse-power at full delivery is just short of 11, and at half-delivery 6, a result (as good as it is) which might be further improved by the use of a simple construction of ball-race eccentric straps.

The construction of the actuating and recording mechanism adopted in the Sinclair variable-throw pump is self-explanatory by the several detailed sectional views shown on Fig. 227. The essential feature of the actuating mechanism is the use of compound eccentrics, the method employed for rotating the inner sheaves being as adaptable for a multiple-throw pump as for a single-throw. The driving shaft is bored through to receive a controlling shaft (*g*), and carries webs (*a*) turned eccentric to (*h*); between these are crank pins (*d*) of extra large diameter, which are cut away on one side to permit of the engagement of pinions (*f*) with internally-cogged sheaves (*e*), and are bolted together in halves to carry on a race between the bolts, straps which move at 120° with one another to an extent determined by the relative positions of the sheaves (*e*) on the eccentric webs (*a*), by reason of the rotation of the control shaft (*g*) by the wheel (*n*) and worm (*l*) carried by the driving-wheel (*m*), which meshes with a pinion (*i*) on the motor shaft (*r*). In order to advance or retard the relative positions of (*e*) on (*a*) the shaft (*g*) is rotated in either direction automatically by switching the small clutch lever (*z*) to the right or left, which action holds by means of the clutches (*v*) or (*x*) either (*g*) or (*t*) from rotating, and this action through the forward train of wheels (*q s*) advances (*g*) relatively to (*h*), or by the reverse train (*t j c*) retards the rotation of the inner shaft relatively to the main shaft (*h*). Motion from either of the two trains of wheels (*q s*) or (*t j c*) can be communicated to the shaft (*g*) by the worm-wheel (*n*), worm (*l*), worm-wheel (*o*), and worm (*p*), in either direction, and enables the stroke of the plungers to be simultaneously regulated to any desired degree to meet the requirements of the boilers.

A variable-delivery effect at constant stroke and speed can be obtained in a 3-throw valve-controlled pump, such as illustrated by Fig. 229, for which certain advantages are claimed over the variable-stroke method, such as that the drive is direct from three cranks placed at 120° on an ordinary driving shaft, and that, owing to the stroke being constant at all deliveries, no ridging of plungers nor tearing of packing takes place. (*N.B.*—There is certainly some ground for this statement in cases where a pump after being run for some considerable time at reduced stroke is suddenly increased to full stroke.) The method adopted to vary the delivery in this pump is a modification of one in general use in belt or motor-driven hydraulic pumps, and consists in holding open the suction valves for a varying period after the completion of the charging stroke of the plungers, which in ordinary practice is controlled by a tappet gear operated by a striker from the dead weight of the accumulator or other suitable manner. In the Thwaites variable-delivery pump a cam shaft D is advanced or retarded relatively to the crank shaft by a specially-designed train of bevel wheels between the crank and cam shafts, in which the position of an idle bevel carried by a radial arm is capable of adjustment as by the rotation of a worm F and worm wheel F', which movement causes the driven end of the lay shaft, and with it the cam shaft D, to change their angular positions as required to hold up the inlet valves A, through cams E, rollers C, and stems B, for varying periods of the down strokes of the plungers. By this means the delivery can be quickly

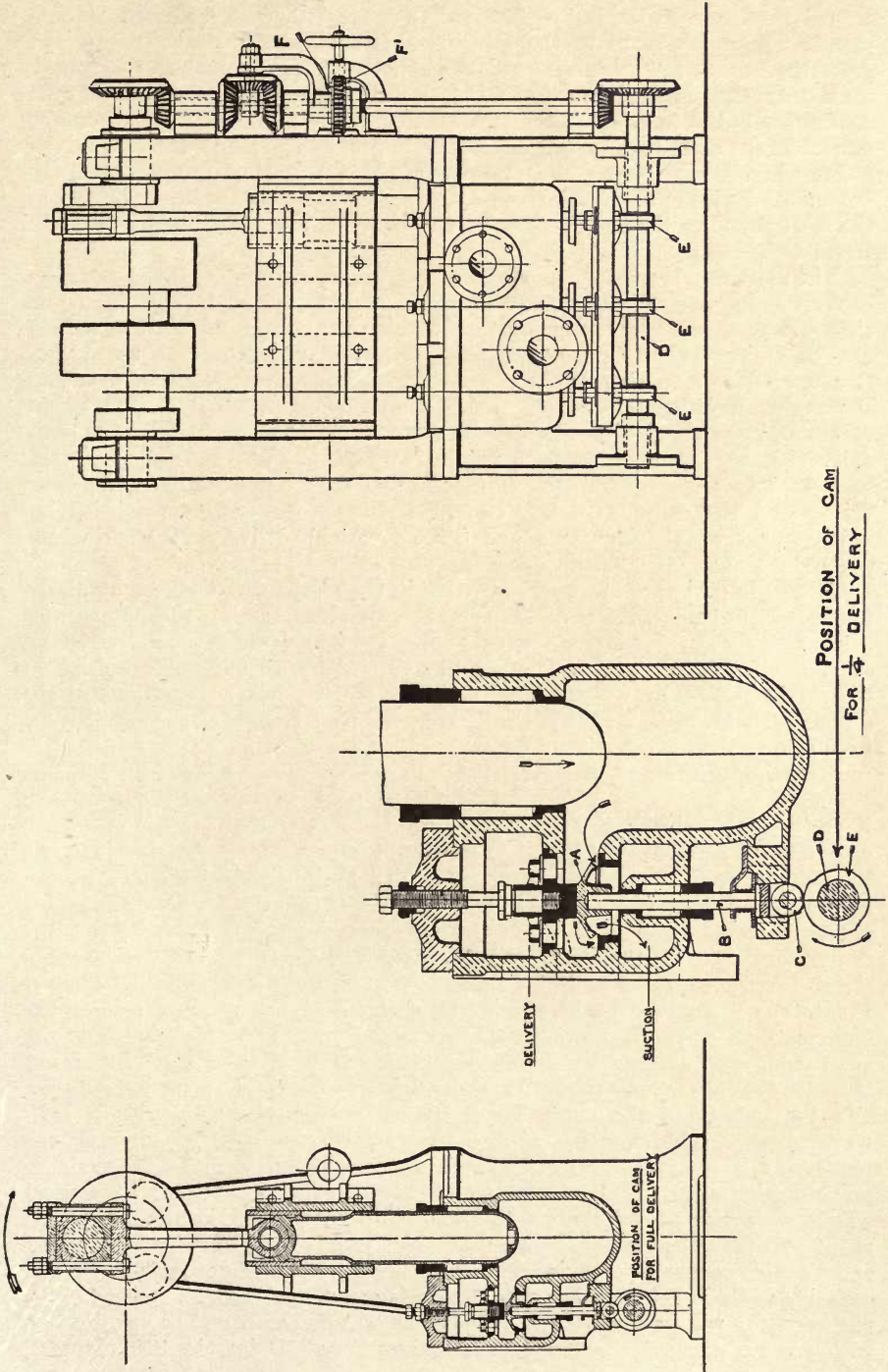

Fig. 229.—Sectional Elevations of Thwaites Variable-delivery Pump, with Constant Stroke and Speed.

altered from zero to the full capacity of the pump, the power absorbed being practically proportionate to the quantity delivered, as the water not forced past the delivery valves is returned through the suction valves to the supply tank. Another method for regulating the discharge of a pump running at constant speed is to admit through a snifting valve a stream of air to one or more barrels, according to the displacement required; and in the belt-driven 3-throw horizontal *vis-a-vis* feed pump with six barrels, shown at Fig. 120, the volume of discharge at constant speed may be adjusted to the requirements of the boiler by thus throwing separately out of action a varying number of units found to be in excess of the demand.

The most simple and compact form of gas, oil, or electrically-driven variable-delivery pump to work on the differential principle explained by Fig. 223 (*i*), is that known as the Clarke-Chapman. In this pump (designed by the writer) one or two pairs of single-acting plungers, working at constant speed and stroke, produce a varying degree of volumetric displacement effect by changing the angular positions of ordinary eccentrics on a driving shaft carried by an extension upwards of a casting in which are formed two or four barrels with valve chambers common for each pair. Two examples of this construction are illustrated by the sectional cuts (Figs. 230 and 231), one arranged to be gear driven and the other as a direct-coupled pump; the first-named being an improvement on the Rousseau and Spence variable-delivery constant stroke pumps, which it resembles in operating on the dual plunger control principle, but differs in an important essential—*viz.*, in the mechanism used for obtaining the required angular differentiation of the two plungers. In the pumps now being described, the relative movements of twin plungers are determined by the lateral adjustment of a coupling nut carried by an out-end extension of the driving shaft, by which means not only are the relative positions of the eccentrics firmly locked, but are clearly recorded for a complete range of delivery from zero to the full capacity of the pump.

Referring to the 2-throw gear-driven pump illustrated by Fig. 230, plungers P and P¹ constituting a couple, are actuated respectively by the fast sheave K and movable sheave K¹, the angular positions of which to one another are determined by the movement of the coupling nut V along the shaft H. At the out-end of V a steel nut T engages with four helicoidal grooves N, the inner end of V forming a sliding fit over a sleeve U connected with the movable sheave K¹, to which it communicates a rotary motion derived from the sliding of T over N, the sleeve U being fitted with keys E. In the position shown the sheave K¹ is at 180° to sheave K, and the displacement of plunger P is totally neutralised by P¹, the indicator rim F here pointing to zero on the dial plate X; when, however, the coupling nut V is forced along the shaft end by retarding or advancing the rotation of the hand-wheel nut G over the screw extension W, the angle of K¹ to K will be reduced, and the output of the pump increased—*e.g.*, when the pointer F is half-way across X the capacity of the two plungers will be as that of one plunger, and at three-quarters the capacity will be increased to half as much again, and will be equal to the two plungers working in consort when the position of F points to FULL, the sheave K¹ then being moved round as to be coincident with K. The rate of delivery of the pump can by this means be regulated to any intermediate degree within its full capacity while in action, when run at speeds commonly used for boiler-feeding purposes. It will be noted there is only one water chamber R communicating with one set of suction and discharge valves S and D for the two plungers,

the *tout ensemble* involving the fewest possible number of parts necessary for a pump of this class.

There is a growing tendency on the part of engineers to dispense with gear drives wherever possible, on account of noise, wear, cost, and the additional room taken up, and to meet the demand for a direct-coupled variable-delivery

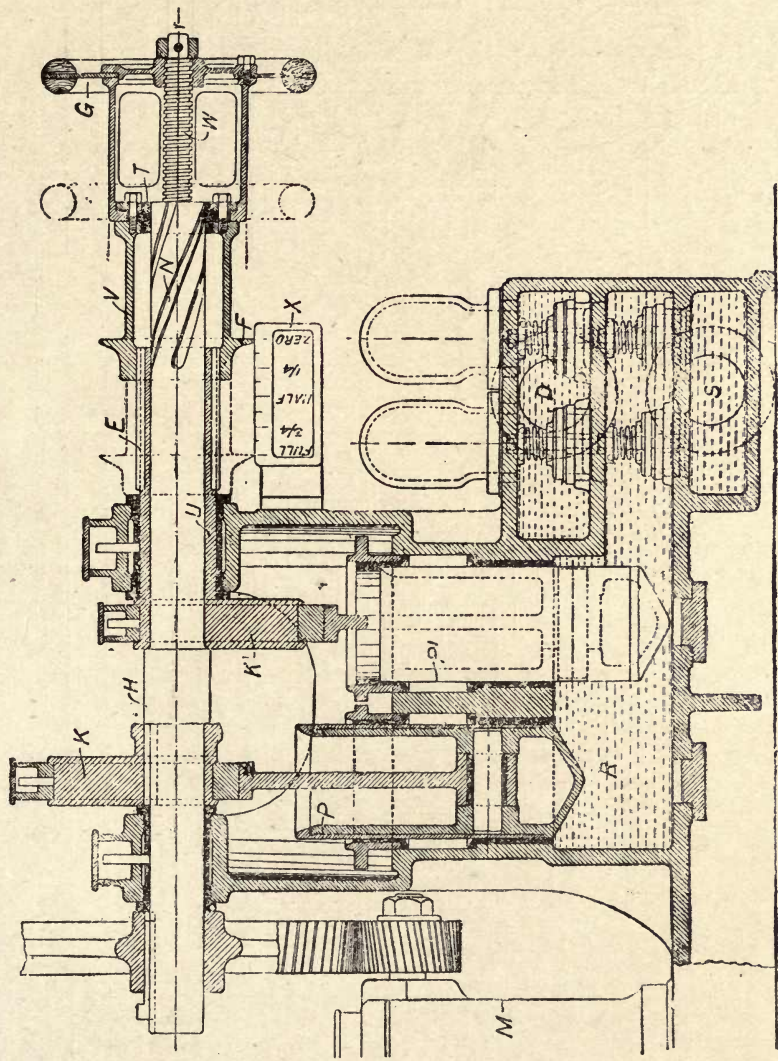

Fig. 230.—Clarke-Chapman 2-throw Variable-delivery Pump, with Compound Plunger Control. (See p. 316.)

boiler-feed and general purposes pump, the direct-driven 4-throw balanced-action high-speed variable-delivery pump illustrated by Fig. 231 has been devised. In this direct-coupled motor-driven pump one pair of plungers P P² are connected to eccentric straps C and C², actuated by a pair of sheaves at 180°, and keyed fast to the shaft H, other two plungers P¹ P³ being connected to eccentric straps C³, which are in turn actuated by a pair of movable sheaves.

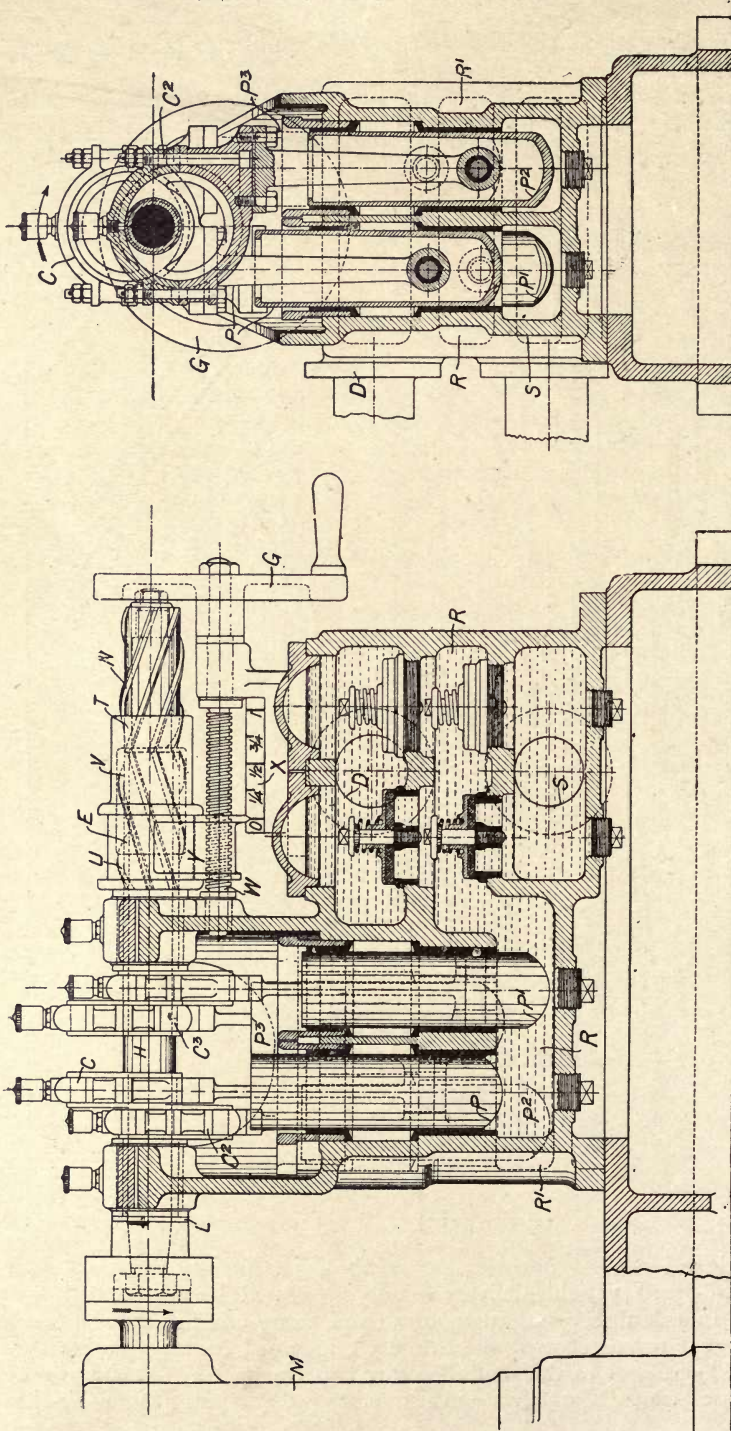

Fig. 231.—4-throw Direct-coupled Plunger-controlled Clarke-Chapman Variable-delivery Pump.

situated also at 180° with one another. The two movable sheaves are cast in steel in one piece with the sleeve E, on which is formed a series of helicoidal threads at an angle of 15° cut "left hand." On a second sleeve N keyed to the end of the shaft H are formed a second series of threads cut to the same angle but "right hand." The angular position of the sleeve E and eccentrics C^3 relatively to the fixed sleeve N on the shaft carrying the eccentrics C^2 is regulated by the lateral position of the coupling nut V, the movement of which along the threaded sleeves E and N is adjusted by the hand-wheel G, screw W, and clutch yoke nut Y; of this the exact position is clearly indicated, as in Fig. 230, by a pointer and index dial plate X.

With a pump of this character having two pairs of plungers, there is not only an absolutely balanced-mechanical action, but the more important advantage in a high-speed pump of obtaining a practically uniform cyclic delivery throughout the full range of discharge from zero to maximum, the water chambers R and R^1 for both pairs of plungers communicating with one suction inlet S and one delivery outlet D, which may be arranged on either side, and the rate of discharge made capable of accurate adjustment under all conditions of pressure and speed by means of the self-locking-thrust-compensating controlling gear, a result that can be obtained in each of these unique little pumps without throwing any end thrust on the driving shaft, which desideratum is of considerable importance in a variable controlling gear of this character when forcing against high pressures.

And it will be seen that, although there are two pairs of plungers, these are so compactly arranged that the width between the bearings of the driving shaft but little exceeds the width usually taken up by an ordinary 2-throw pump of equal capacity. In the illustrations the two "movable" sheaves are shown in position relatively to the two "fast" sheaves, so that each pair of plungers constituting a couple work opposite one another, when the delivery of pressure flow from the pump is reduced to *nil*.

To increase the rate of delivery in the gear-driven pump (Fig. 230), the wheel (G) is pulled in the direction of the shafts' motion, so as to advance the relative positions of the fast and movable eccentrics until the required rate of delivery is obtained, as indicated by the dial plate; if, however, the pump is forcing against a pressure too high for this to be feasible, a stop valve connecting the plunger chambers ($R R^1$) with the suction chamber (S) is opened to reduce the torque temporarily, to enable the feed to be adjusted without having to stop the pump. In the high-speed pump (Fig. 231) this difficulty does not exist, for the sufficient reason (1) that the area of the plungers is relatively less, and (2) that a much greater purchase is obtainable by the fixed controller wheel.

In taking a retrospective view of the various available methods for obtaining a variable pressure-flow with a pump while running at constant speed, we find that this result can be obtained in quite a number of different ways; for instance, the most obvious method is to use a by-pass between the suction and delivery ends of the pump, which is applicable to most makes of valveless rotary pumps, a case in point being the Vincent rotary plunger pump (*vide* Fig. 255), which is adapted in this manner to constitute a hydraulic clutch for automobiles. Then again, the same result can be obtained by an operating gear for timing the closing of the suction valves—*e.g.*, the Thwaites pump (Fig. 229) is regulated on this principle; this is the method also most usually employed in belt and gear driven, also direct-coupled force pumps of the constant-speed type for charging hydraulic accumulators. Other methods include the use of a link motion between the plunger and the actuating crank for varying the stroke (*vide*

Fig. 221), examples (a) and (b), a third example (c) also illustrating another method known as the lost-motion variable gear, and is one commonly adopted for feed pumps in automobile steam engines, and also as a means for regulating the stroke of lubricating pumps.

As only too well known, a leakage of air into the suction end of a pump will prevent it from drawing water; this method also has been adopted to regulate the delivery of a multiple-plunger pump (*vide* Fig. 120), and is the simplest of any. The favourite method to this end however, with many is to cause the plunger to work with a variable stroke by means of movable eccentrics or cranks; one method on this principle consists in mounting one eccentric over another (*vide* Fig. 227), another to use a sliding sheave (*vide* Fig. 222), and for longer strokes by mounting a crank disc over an eccentric sheave (*vide* Fig. 223), example (h); the outer eccentric sheave or crank disc in pumps constructed to operate with a variable stroke according to this method is arranged so that the outer disc or sheave can be moved round on the inner sheave, and in this manner can be caused to co-ordinate with or neutralise one another.

Variable delivery on the dual plunger system has most points for recommendation (*vide* Figs. 230 and 231), owing (1) to the plungers being operated with a constant stroke for all rates of delivery, (2) to the absence of valve controlling gear, and (3) to the elimination of all variable stroke mechanism; according to this method (adopted in battleships and by the mercantile marine for supplying fresh water to the boilers) a pair of plungers are arranged to work at constant stroke in communication with one common valve chamber, and a variable delivery is obtained by altering the angle of the eccentric used for driving one plunger relatively to that for the other, and in such manner that two plungers constituting a couple can be caused to move at even angles when the volumetric capacity of the pump will be equal to the combined displacement of both plungers; or, the pair of plungers may be caused to partly or wholly neutralise one another. In addition to the advantages named, a pump operating according to this method can be made to work with a perfect mechanical and hydraulic balance, and, what is important, is not subject to the formation of ridges on the barrels or plungers.

Liquids being for all practical purposes incompressible, it is obviously necessary from a consideration of the foregoing for the displacement to be independent of the speed in all types of plunger pumps; but in centrifugal pumps a variable delivery is quite feasible by the simple expedient of introducing a resistance to the outflow, in consequence of this property, centrifugal pumps can be usefully applied for supplying water to a tank, cistern, or reservoir, and for automatically maintaining the pressure head to any predetermined level, as by a float-regulated valve, the interposition of a resistance to pressure flow not materially increasing the head resistance, and in contra-distinction to all piston or plunger pumps for any throttling action to have the effect of reducing the power required. Hence for the purposes named, especially for the supply of large volumes at comparatively low pressures, pumps constructed to operate on the centrifugal principle present the most practical means for obtaining a variable delivery at constant speed.

In obtaining a variable and reversible transmission by hydraulic power there are several methods for selection, the suitability of one hydraulic transmission system over another depending on the purpose of its application; the two most important applications of this power engaging the attention of engineers at the present time are the propulsion of road-cars and ships, both of these applications requiring power to be transmitted at a variable and reduced speed

in either direction. For the first-named purpose, it is obviously important for the size and weight of the transmission mechanism to be kept down to the lowest limit, for which reason a high working pressure is more suitable than a low; but for maritime propulsion the principal determining factor next to reversibility and a variable speed transmission is that of efficiency and certainty of action under all sea-going conditions.

The gain in transmitting power from a high-speed internal combustion engine to the driving wheels of a road car by hydraulic means is mainly due to its more silent action when applied without the intervention of gearing, under which limiting conditions any one of the following transmission systems may be used:—(1) A combined pump and motor of the revolving type, such as the Hall transmission (*vide* Fig. 225), in which the crank shaft actuating three or more pump plungers is driven direct from the primary motor at constant speed and stroke, the pressure flow from the pump being supplied to a series of three or more motor pistons connected to a fixed crank, the stroke of which can be varied so that pump and motor may either be locked and caused to revolve together, or to run at differential speeds. (2) A revolving pump of the kind shown diagrammatically in Fig. 232, and in detail in Fig. 232*a*, may be used, in which a series of plunger rams M are caused to revolve with the star-barrelled hub B concentrically with the outer casing G. In this rather remarkable variable

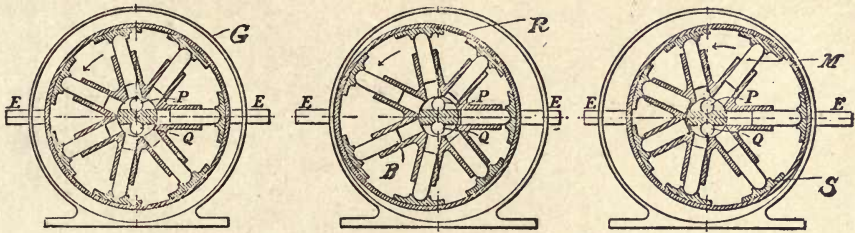

Fig. 232.—Diagrams showing the Action of Hele-Shaw's Combined Variable-delivery and Reversible Action Valveless Rotary Pump.

delivery pump, recently described in a paper read before the Inst. Naval Architects, the outer ends of the plunger rams bear against slippers S, which in turn bear against an inner ring R, caused to revolve about a centre that may be either concentric with the outer casing G (as shown to the left of the figure), or may be moved by the connection E to any intermediate position to discharge, not only a variable pressure flow, but to reverse its action, so that the suction in one position may be through the portway P in the fixed shaft about which the barrels revolve, and in the reverse position (as shown to the right) may be through the portway Q. This form of pump is peculiarly adapted for being driven at a high speed, owing to its well-balanced and continuous action, and would seem, therefore, suitable for direct coupling to a car motor, the power being transmitted to the driving wheels either through an ordinary 3-cylinder hydraulic motor; or, through a pair of revolving motors—*i.e.*, one in each driving wheel, as used on the "Compagne" hydraulic transmission system—which consists of a Hele-Shaw reversible flow revolving plunger pump, as shown in Fig. 232*a*, in combination with a pair of pressure-oil transmitters, also on the revolving plunger principle, but which differs from the reversible pump or motor, as illustrated, in that the plungers M, instead of being held up to their work by shoes S and guide-ring R, the plungers in the Compagne motor are each fitted with a runner wheel, which rolls over a circular cam track forming

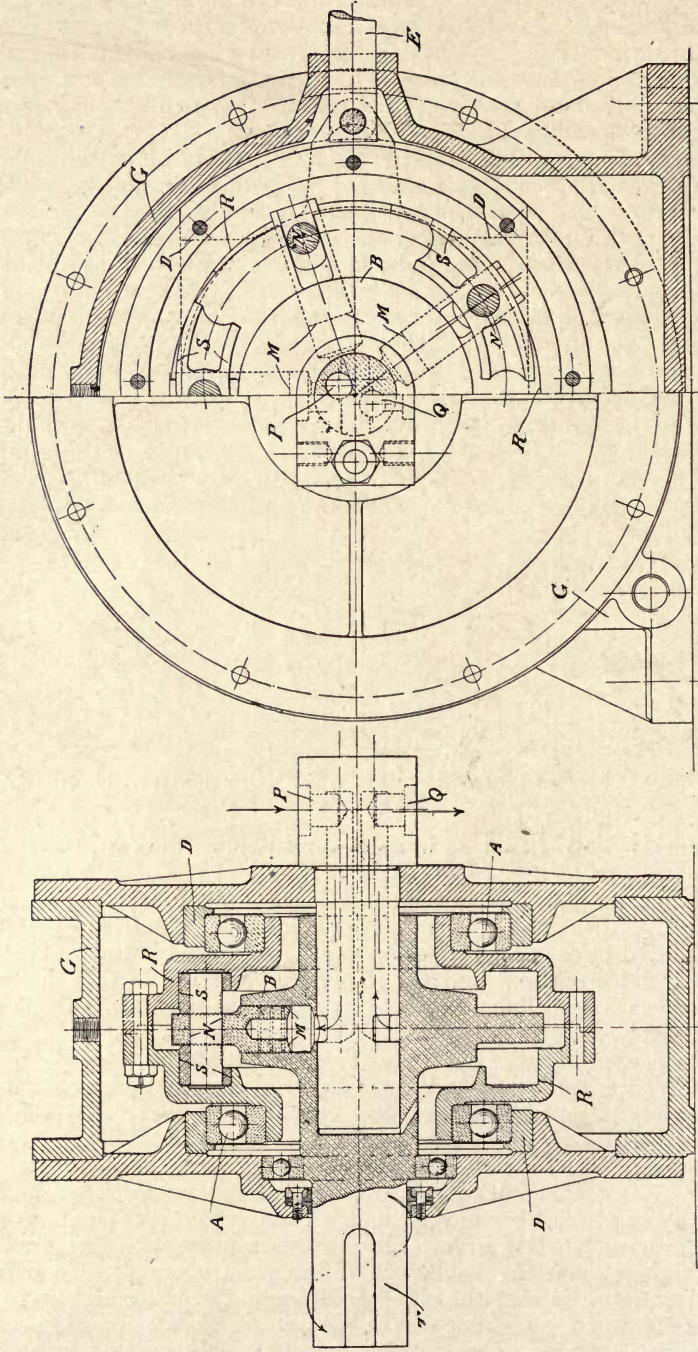

Fig. 232a.—Cross-sections of Hele-Shaw variable and Reversible Flow Radial Pump or Motor.

part of the guide ring, and by this means each plunger may be caused to move through several strokes during a single revolution of the motor, which may be connected direct to the road-wheel without the intervention of gear-wheels.

In the reversible flow high-speed pump or motor illustrated by the cross-sections, Fig. 232a, will be recognised a development of the diagrams shown in Fig. 232, inasmuch as the plungers M, of which there are five, move radially in barrels bored out of a disc-block B, forming part of the driving shaft T. The plungers are connected by pins N to shoes S, and as these are constrained to revolve in a track contained in the guide-ring R, which can be moved out of centre with the driving shaft T; a radial movement can be imparted to the plungers, as above explained in reference to the variable flow revolving motors or pumps illustrated by Figs. 224 and 225. In the pump or motor now being considered, a guide-ring R runs in ball-race bearings A, carried by guide chairs D, which are free to slide along ledges forming part of the covers G. By this means a lateral movement imparted to the bearing chairs D, as by a controller rod E, can be made to vary the stroke of the plungers M from nil—*i.e.*, when the centre of R is coincident with T; to the full stroke, as when R is moved to its extreme position, at either side of the shaft centre.

It will be seen that there are no valves as such, the pressure distribution being effected by the movement of the driving shaft, over a fixed shaft containing inlet and outlet portways P, Q, which are caused to communicate with the barrels M in succession during each revolution of the driving or driven shaft T for the inflow and outflow of pressure oil. The direction of pressure flow can be quite easily and quickly reversed by sliding the bearing chairs carrying the revolving guide ring from one side to the other of the shaft centre—*e.g.*, the inflow and outflow will take place, as shown by the arrows, when the shaft is driven in a clockwise direction, and with the controller pulled to the right; but when this is pushed to the left, either the direction of the shaft, as when used as a motor; or, the direction of the pressure flow will be reversed, when used as a pump.

The most remarkable feature of this hydraulic power transmitter is its smooth running at high speeds, and consequently when this transmitter is applied as a variable delivery and reversible flow pressure pump it is peculiarly adapted for direct coupling to an electric motor for the many purposes for which hydraulic power can be usefully applied, such as bascule and swing bridges, turrets, turntables, cranes, and steering gears, its application to the last-named purpose being particularly appropriate for oil motor-driven ships.

As another alternative (3), a high-speed variable-delivery pump, such as illustrated by Figs. 230 and 231, may be used in combination with a 3-way valve for reversing the direction of pressure flow from the pump to the motor. And again (4), a rotary pump of the sliding-vane type (as, for instance, illustrated by Figs. 248, 249) may be used; or (5) even a multi-stage centrifugal pump and turbine drive, which latter method is better adapted for transmitting power to a ship's propeller, judging from some results obtained with a hydraulic transmitter operating on the turbine principle, known as the Föttinger transmission system, which, according to *Engineering*, consists of a primary water-turbine wheel mounted on the primary shaft directly coupled to a steam turbine of some 200 S.H.P., and two secondary water turbines mounted on the propeller shaft, with two stationary guide wheels, the series of primary, secondary, and guide wheels constituting a closed circuit, through which the water moves in a continuous flow, the first primary wheel taking the water immediately from the last secondary wheel. The water is given pressure and velocity in the primary wheel, whence

it is delivered directly to the first secondary wheel, where a part of the energy imparted to the water is absorbed in driving the propeller shaft; the water then flows through stationary guide blades, which are connected to the outer casing, and, leaving these blades, passes through the second secondary turbine, which absorbs the remainder of the energy, after which the water still flows at a certain velocity round again to the primary wheel.

The blades of the primary wheel are curved back, and those in the first

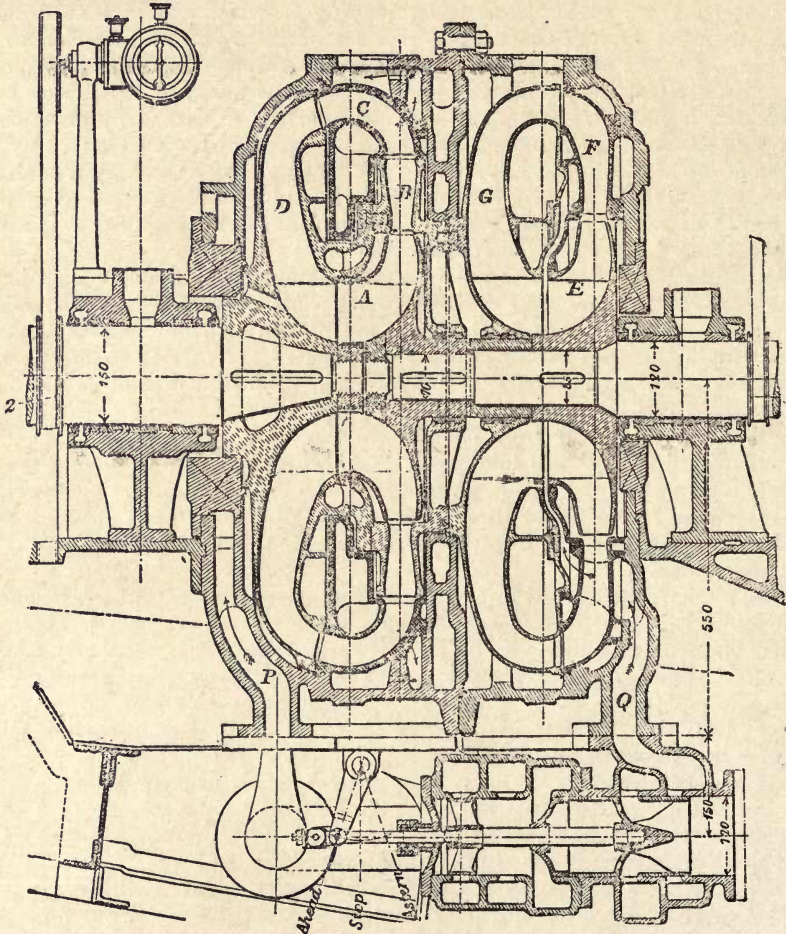

Fig. 233.—Föttinger Hydraulic Turbine Action Variable Transmitter.

secondary wheel are cup-shaped, while the blades in the guide wheels are curved in the opposite direction, the blades in the second secondary wheel being nearly radial. Referring to the illustration (Fig. 233), and describing the ahead transmitter shown to the left: A is the primary wheel, B the first secondary wheel, C the guide blades, and D the second secondary wheel; the wheel B is connected to D, which is mounted on the propeller shaft (2). In the astern transmitter to the right, E is the primary wheel, F the guide blades for

reversing the direction of flow to the secondary wheel G, which drives the propeller shaft astern, it being coupled to the wheels B and D; from G the water again passes to the wheel E.

In manoeuvring, water is fed through the port P to set the ahead turbine into action, when all water in the astern wheel is drained away; and *vice versa*, to go astern, water is fed through the port Q to the astern turbine, and simultaneously all water in the ahead turbine is drained away, the time occupied in changing from full speed "ahead" with the propeller shaft running at 270 revolutions per minute to full speed "astern" with shaft running at 250 revolutions per minute is less than one-third of one minute, the primary turbine running at 1,600 revolutions per minute. In regard to the efficiency gained between the primary and secondary shafts, the transmitter, it has been ascertained that with the primary turbine running at 1,100 revolutions per minute and absorbing 122 S.H.P., that the overall efficiency with the secondary turbine running at 250 revolutions per minute—*i.e.*, at a ratio of 4.5 to 1—was 83 per cent., this percentage remaining practically constant between 240 and 280 revolutions per minute, after which it fell rapidly until 500 revolutions per minute (the maximum speed) was obtained, the torque then being *nil*, according to which the speed of the propeller shaft under no conditions could reach a dangerous limit; the maximum torque obtained at *zero* is just double that obtained at the designed working speed—*viz.*, 250 revolutions per minute—while the power absorbed by the primary turbine ranged from 130 at *zero* to 95 with the propeller shaft running at its maximum speed, which would indicate that a turbine transmission is not at all suitable for a road car, as for this purpose the maximum torque should not be less than four times that required in running on the level; but as in the propulsion of a ship the resistance decreases rapidly with diminishing speed and a wide range of torque is not necessary, a transmission system capable of working with an overall efficiency between pump and motor of 83 per cent., and at the same time serve the useful purpose of a combined reducing and reversing gear cannot fail to be usefully employed in connection with steam turbines and internal combustion engines, when used for maritime propulsion. And, whereas an efficiency of 70 to 80 per cent. of the B.H.P. of the primary motor can be obtained on an automobile, with a hydraulic transmission system comprising a variable delivery plunger pump and piston motor, constructed to work at high pressures and with a sufficiently wide range of torque for the steepest gradients, it is evident that such form of transmission can be economically applied to motor-buses and other vehicles used for town work—where frequent changes of speed is imperative—owing to its comparative freedom from wear and tear in speed changing, and more particularly to its silent action.

CHAPTER XVII.

MASSE-CUITE, ROTARY, OSCILLATING, AND WIND-POWER PUMPS.

Masse-cuite Pumps.

THE use of pumps of this kind on a large scale is mostly met with in sugar factories, where they are required to convey "masse-cuite," variously known as green or wet sugar, during the process of crystallisation from the vacuum pans, or dehydraters, to open or closed tanks provided with stirrers, whence after sufficient time has been allowed for curing—*i.e.*, for cooling and formation of crystals—the resultant product, which may be either fluid masse-cuite or stiff masse-cuite (concrete sugar, according to the degree of hydration), is then passed on to a battery of "centrifugals" to be separated from fluid molasses; any further conveyance of the now dried sugar being effected on one level, either in trucks or in a kind of vanner—*i.e.*, an open trough suspended on spring hangers—to

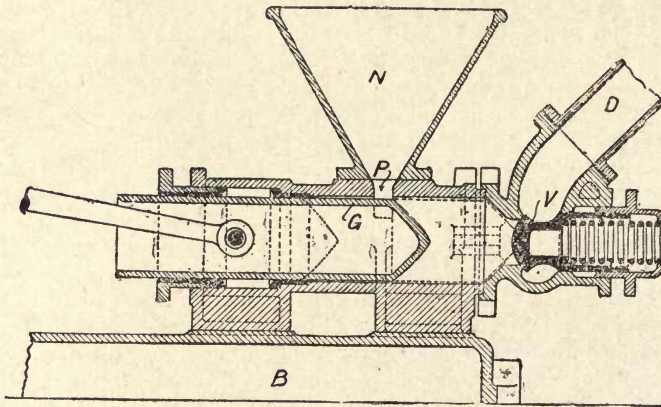

Fig. 234.—Section of Horizontal Ram-plunger Force Pump for Green Sugar.

which a quick vibrating movement is communicated by an eccentric or short-radius crank motion. In the handling of fluid masse-cuite compressed-air displacer tanks have one advantage over all other pumps—to wit, in consequence of diminished interference with the natural process of crystallisation; however, displacer pumps owing to their slowness are not so generally adopted as other forms of pumps, such as are, for example, illustrated by Figs. 234 to 239. Among these, perhaps, the type of plunger force pump, as shown by Figs. 234 and 235, is the best known, this resembling in some degree plunger-controlled condenser air pumps, in which no inlet valve is required. The purpose, however, of utilising a plunger controlled inlet in this particular case is to ensure the admission of a greater charge from the hopper N than can be obtained in the ordinary way;

in operation, as admission only commences at about half-stroke, the resulting degree of suction effect of from 6 to 8 lbs. per square inch thereby produced overcomes the viscosity of the contents of the feeding hopper in sufficient degree to three-fourths fill the pump barrel at each out stroke when run at a plunger speed of about 30 to 36 feet per minute, a pump with an 8-inch plunger by 16-inch stroke having a capacity of from 8 to 10 tons per hour, varying according to the viscosity of the sugar. In Fig. 235 a heavy ball outlet valve lifting vertically is used in place of the spherically-seated spring-closed valve V (Fig. 234),

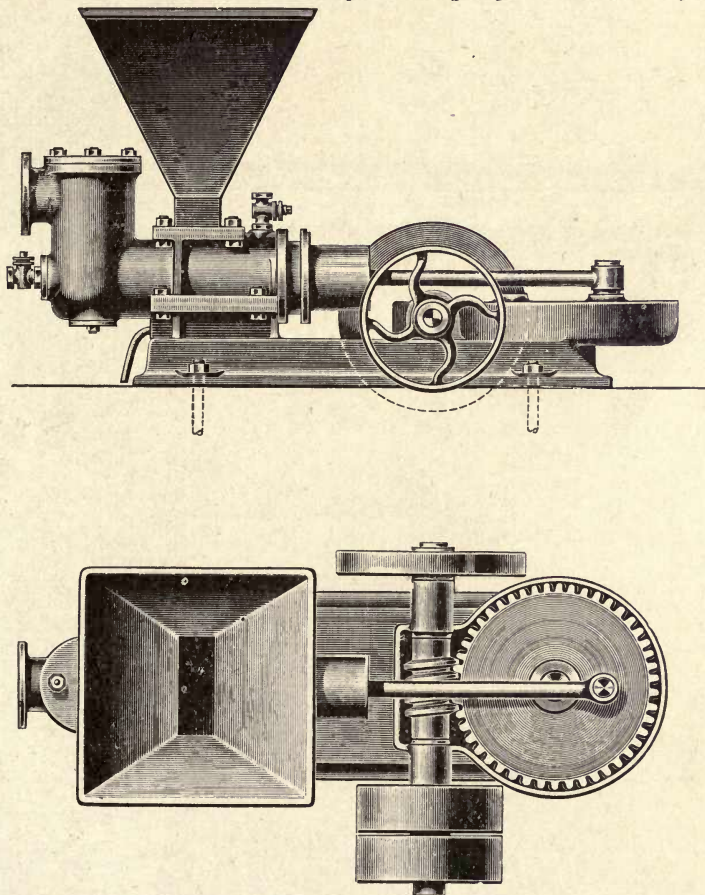

Fig. 235.—Elevation and Plan of Watson and Laidlaw's Plunger Masse-cuite Pump.

the inlet port P in both pumps extending right across the full diameter of the barrel; the plunger G is made of conoidal form at its inner end, and the barrel shaped to correspond, this being necessary to avoid abrupt change of direction at the delivery end of the pump in order to obviate, as far as possible, the formation of solid masse-cuite. Another form of pump for a similar purpose is illustrated at Fig. 236, this being an adaptation of the well-known chain pump, and can be employed usefully for lifting masse-cuite of all grades vertically to a distance separating one floor from another; for concrete sugar this type of

pump is also combined with a pugging mill arranged over the inlet, and in other respects constructed for hard usage.

Two types of pumps specially suited for forcing thick fluids, such as molasses, tar paint, etc., are shown at Fig. 237; of these, the Quinton archimedean

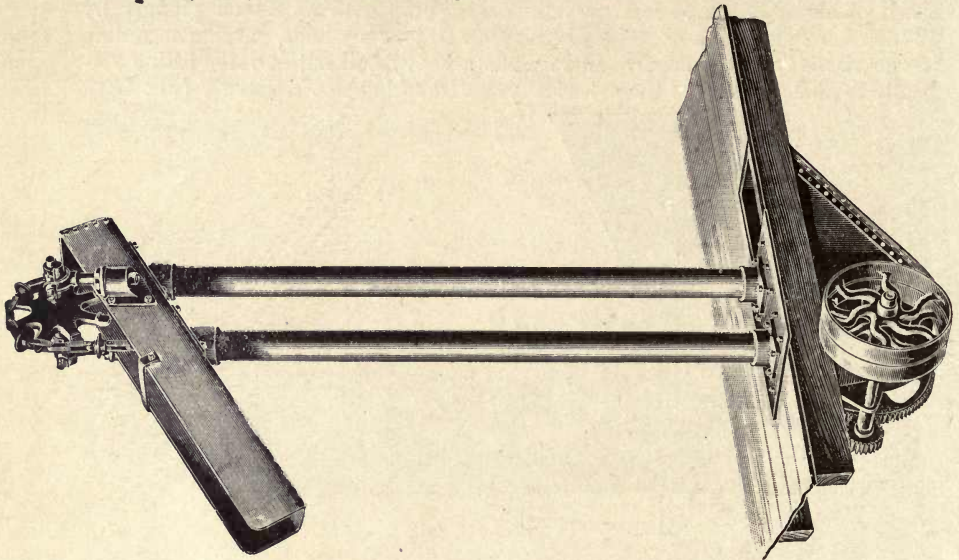

Fig. 236.—Arrangement of Chain Pump for Stiff Masse-cuite

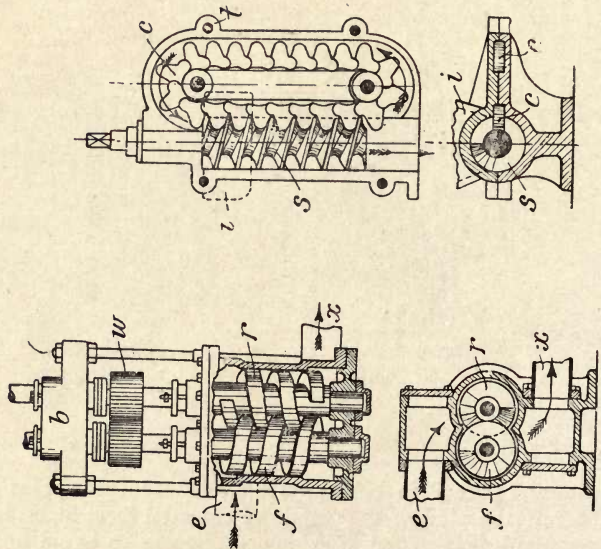

Fig. 237.—Sectional Views of the Quinton and Triben Archimedean Pumps for Semi-fluids.

thruster (of American origin), with right and left-hand screws (*r* and *f*) is arranged with the inlet (*e*) at the top, and outlet (*x*) at the bottom, the two pump screws being connected by spur-wheels (*w*), and held in correct position endways against the pressure by adjustable thrust bearings (*b*). In the second

example, known as the Triben pump, and constructed for similar purposes, a single screw (*s*) is used, the inlet being at (*i*); the essential feature of this pump is the use of a chain comb (*c*), which causes the fluid between the coils or threads to move longitudinally as a nut on a bolt; the casing enclosing the screw

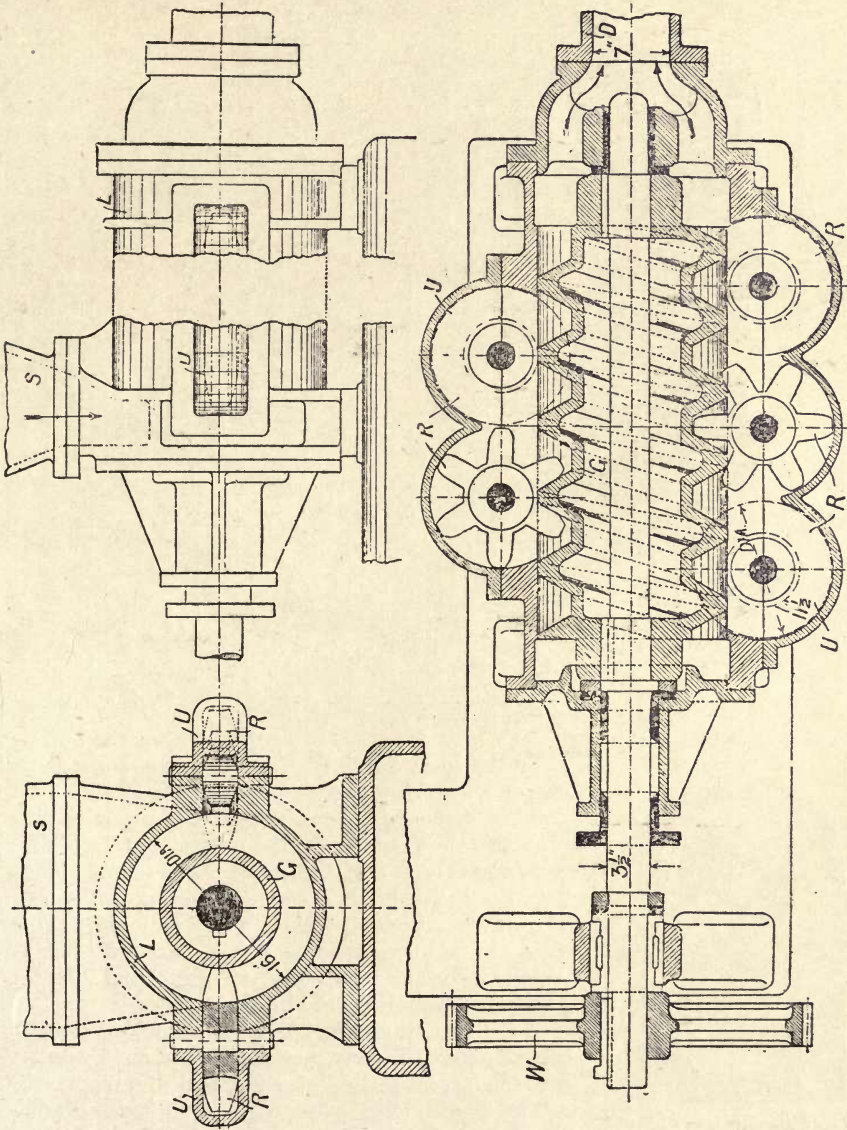

Fig. 238.—Cross section, Elevation, and Sectional Plan Views of Maxwell Archimedean Force-pump for Viscous Fluids and Semi-solids, such as Masse-cuite. (Capacity, 20 tons per hour.)

and chain is also constructed in halves, and can be separated for cleaning by the removal of the four thumb-screws (*t*) in a most convenient manner.

An interesting form of archimedean force pump for viscous or semi-solid matter such as masse-cuite, mortar, and the like, is illustrated at Fig. 238. A

special feature of this pump is its immense strength, it being proof against fracture with any material that can be fed into the receiving end, and combines for concrete sugar, both puging mill and conveyor in one machine, and is

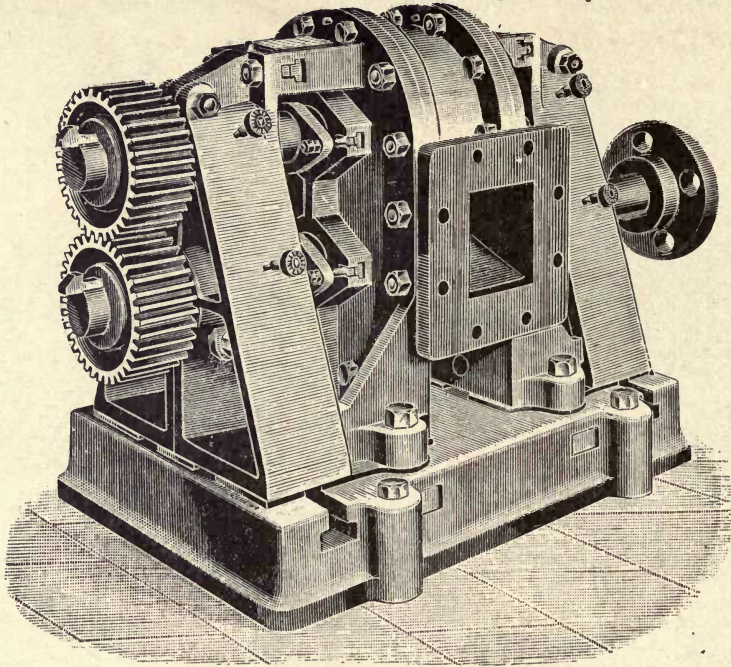

Fig. 239.—“Drum” Pump for delivering 30 Tons or Masse-cuite per Hour against a Head of 90 Feet.

also adapted for conveying concrete in connection with building operations. This pump consists essentially of a cored helix G, caused to rotate within the barrel L by the gear drive W. The barrel is slotted at one or both sides, and carries a series of star displacement revolving combs R, held in place by the caps U, these causing the material fed into the receiving hopper S of the pump to be forced along between the helices G to the delivery outlet D. The advantage of the helix form of force pump over the plunger type is due to its continuous action, its greater capacity, strength, and adaptability for semi-fluids of all consistencies.

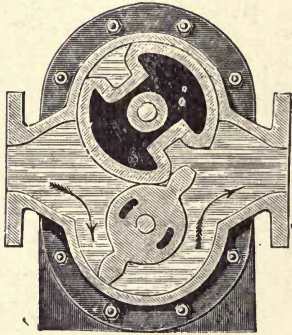

Fig. 240.—Section of the “Drum” Pump

The illustration (Fig. 239) is an example of a large capacity specially constructed rotary pump for dealing with 30 tons of fluid masse-cuite per hour against a total head, including friction, of 90 feet. From an examination of the section (Fig. 240), it will be noted that the displacer element in this pump consists of a revolving drum armed with two wing pistons, which register with corresponding recesses contained in a second revolving drum; the displacement capacity of this form of pump can be reckoned as the area represented by the annulus

consists of a revolving drum armed with two wing pistons, which register with corresponding recesses contained in a second revolving drum; the displacement capacity of this form of pump can be reckoned as the area represented by the annulus

swept by the wing pistons X, by the length of the drum casing, less the thickness of the wings. For dealing with strained liquids in volumes ranging upwards to 100 tons per hour to heads not exceeding 50 feet or so, this type of pump not only has the advantage of varying its capacity in direct proportion to its speed as obtaining in plunger pumps, but is entirely without valves. The pump is also reversible, besides giving a nearly continuous flow, and consequently is able to utilise without air vessels the energy represented by the moving column as in centrifugal pumps. Pumps of this class are not usually run at a wing velocity exceeding 10 feet per second, so that loss of power by reason of a certain churning action of the wings is not considerable; they may be also used for suction lifts up to 20 feet, when provided with a foot priming valve; and, further, as the power transmitted to the driving shaft is communicated direct to the water from one pair of revolving pistons, the mechanical efficiency when coupled direct to the prime mover, as in the case of a gas or oil engine, should be high.

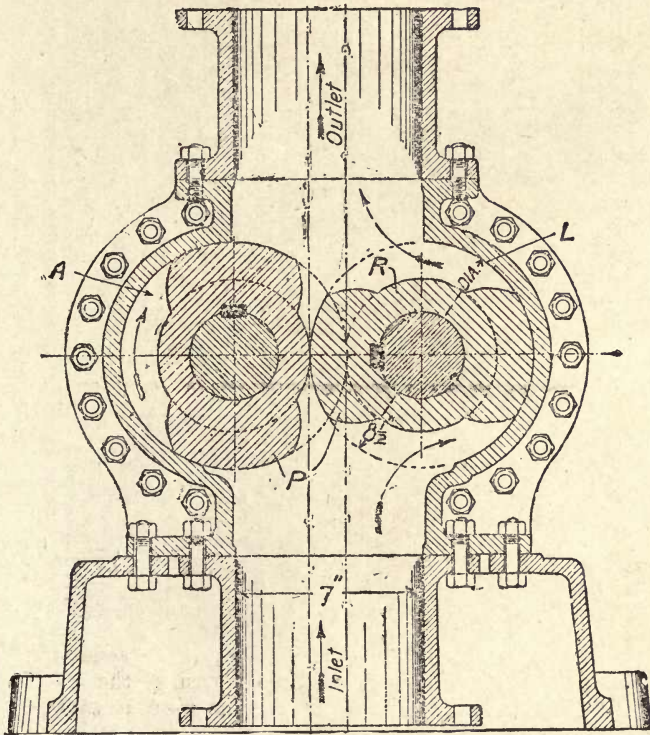

Fig. 241.—A-cme Rotary Pump. Capacity, 42,000 gallons per hour.

Rotary Pumps.

This useful class of pump is constructed in a variety of forms, and owing to their compactness are found to be very suitable for those purposes wherein lack of space prevents the application of the ordinary plunger pump; another important factor in their favour is due to their entirely "valveless" action, and as they are adapted for a wide range of speed without materially affecting

their ratio of delivery and pressure capacity, pumps of this class are particularly adaptable for forcing to comparatively low heads liquids varying in quantity from 20 to as much as 3,000,000 gallons per hour.

The most notable types of rotary pumps may be classified as those having (1) a 2-part cylindrical casing containing either one revolving piston wheel and

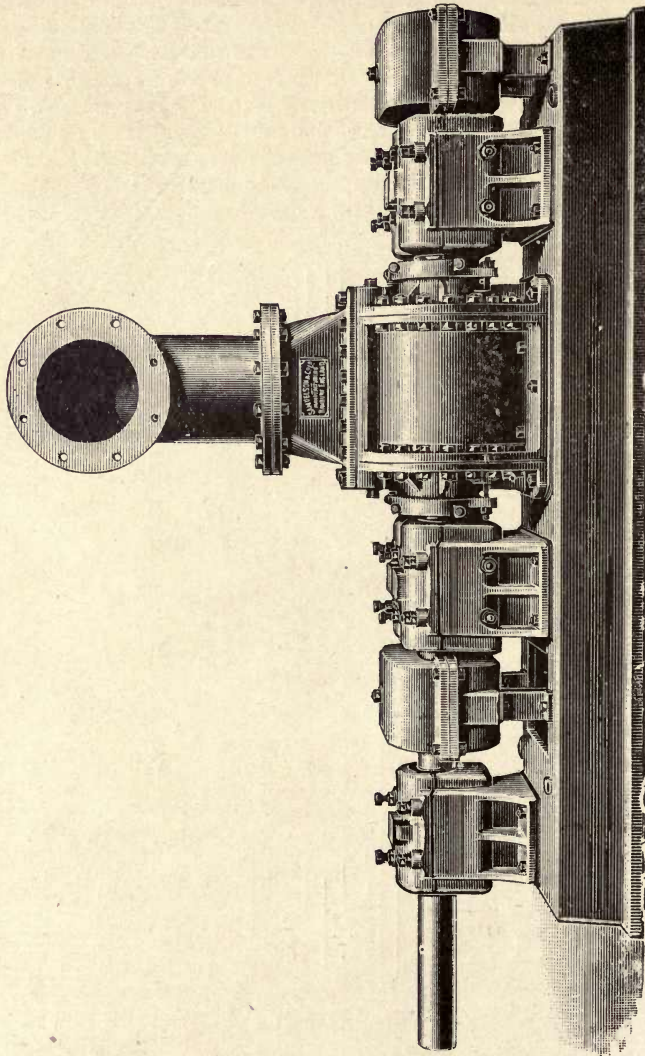

Fig. 242.—Samuelson Acme High-lift Mine Pump.

one revolving drum, or two revolving piston wheels; (2) those having a revolving drum arranged eccentrically within a cylindrical casing, the drum being provided with either one or more sliding radial vane pistons, a series of hinged piston vanes, or rollers; (3) pumps with single or multiple drums provided with axially arranged sliding piston vanes, and caused to revolve concentrically between helicoidal or cam-shaped covers; (4) pumps with eccentric pistons

combined with pivoted vanes. Of these four varieties, the first-named are made in the largest sizes, pumps such as the Acme (Figs. 241 and 242) are supplied to deliver up to 80,000 gallons per hour, and the Connersville (Fig. 243) to 1.5 million gallons per hour. In this type the maximum capacity for a given size of pump casing is obtained, both rotors being displacer pistons; of these, again,

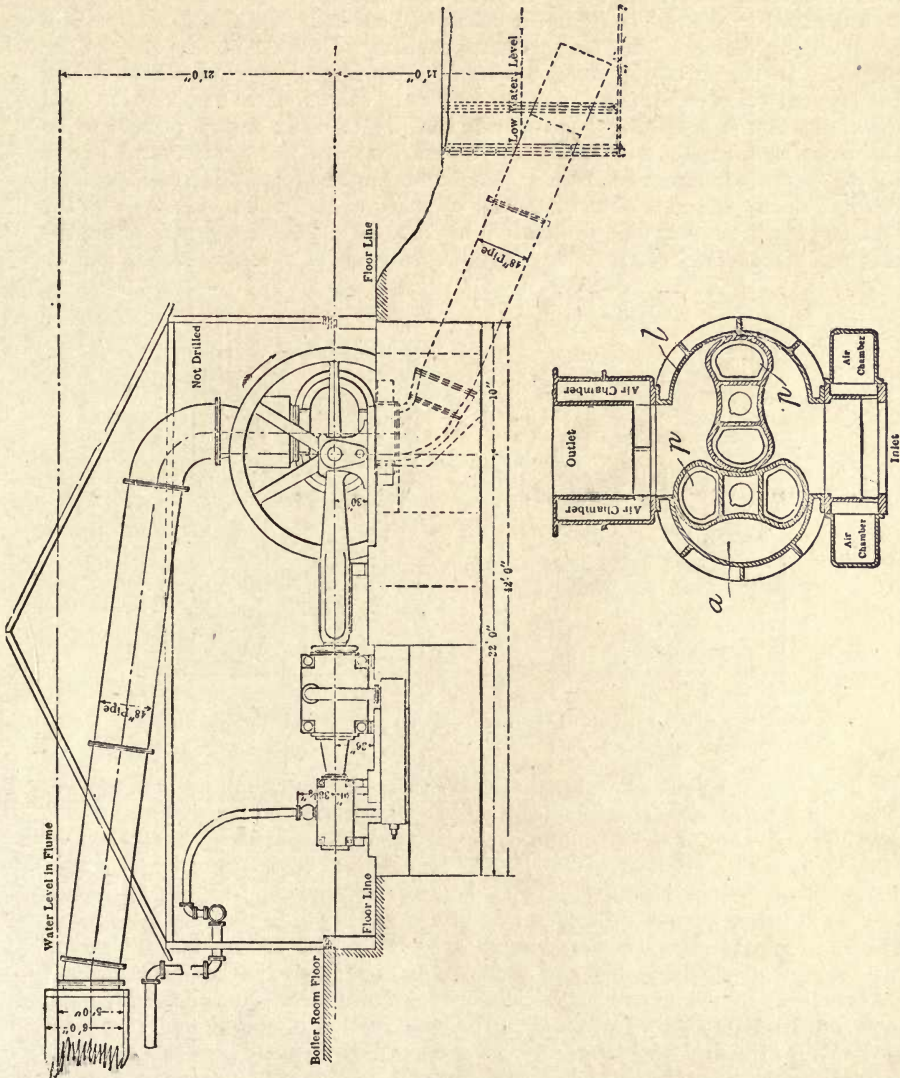

Fig. 243.—Cross-sections of Connersville Cycloidal Rotary Pump, and Irrigation Pumping Plant of 108,000 gallons per minute capacity

the crescent-shaped pistons C (Fig. 244) afford a greater ratio of displacement area in the 2-part casing A than can be obtained by the rectangular-shaped pistons P (Figs. 241 and 243), as used in the well-known Bramah or Root's blower, and Acme and Connersville pumps, both of which require to be gear connected on both sides when used for large outputs. Fig. 242 illustrates this

construction with out-end bearings on an electrically-driven pump, for delivering 42,000 gallons per hour against a total head of 140 feet, in a mine at Guisboro'; this plant, in delivering 27,000 gallons per hour, indicating a consumption of 32 E.H.P.—i.e., 0.60 per cent. efficiency—the water horse-power alone representing 19 W.H.P.

However, by far the largest pumps of this class have been built in response to a demand in the rice irrigation districts of Louisiana and Texas, where there are pumping plants having an aggregate capacity of over 1 million gallons per minute. In course of the development of these large irrigation plants during the last ten years or so, the annual statement of the expenses of operation, and especially of the fuel bills, have shown the plants using rotary pumps to be the most economical, due partly to the efficiency of the pumps, and partly to the high-class direct-connected compound condensing Corliss engines used to drive them. An idea of the immense capacity of these pumps (known as the Connersville cycloidal, and illustrated by Fig. 243) may be gathered by the statement that four of them are together capable of raising 108,000 gallons

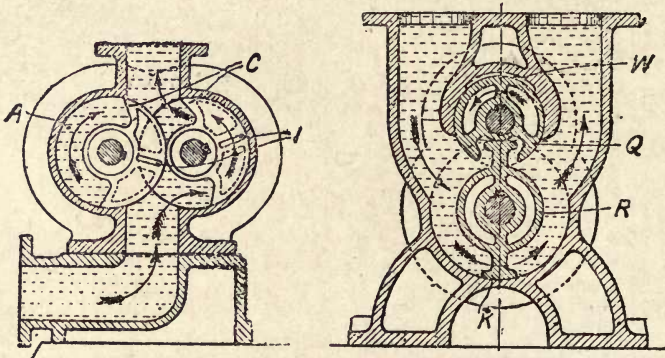

Fig. 244.—Cross-sections of Goldsmidt-Hahlo and Greindl Rotary Pumps.

per minute to a height of 31 to 35 feet from the Neches Canal, near Beaumont (Texas) for distribution along some 18 miles of laterals in the rice fields.

The pumps are of the two-lobe cycloidal type (illustrated by Figs. 170 and 243), of 39 inches pitch diameter, having impellers 52 inches long by 58 inches diameter, carried by shafts 11 inches diameter running in bearings 30 inches long, each pump having a displacement of 500 gallons (imperial) per revolution. There are four tandem compound condensing Hamilton-Corliss engines (one for each pump), with cylinders 18 and 36 inches diameter by 48 inches stroke, which are supplied with steam at 140 lbs. pressure from two water-tube oil-fired boilers, each rated at 400 H.P. In regard to the construction of the pumps, it will be noticed that the cycloidal lobes afford a greater displacement area (*a*), Fig. 243, than the rectangular-shaped lobes used in the Acme pump, but are not so suitable for a high pressure head as the latter, owing to their radial formation and much greater surface contact, although the pressure resisting capacity at the ends is the same in both types; however, judging from the results disclosed by a carefully-conducted series of tests, the leakage in pumping against the low pressures common to irrigation plants may be taken as negligible considering

that the overall efficiency of the pumps and engines is above 80 per cent., which is much higher than can be obtained with any form of centrifugal pump.

TESTS OF MAIN PUMPING PLANT, NECHES CANAL COMPANY, NEAR
BEAUMONT, TEXAS.

SUMMARY OF RESULTS.		
Duration of test, hours	10	5
Pumps in use,	2	..
Mean I.H.P. of 4 engines,	4
Mean I.H.P. of 2 engines,	657	1,320
Revolutions per minute (mean),	55	..
Difference of level between suction and discharge,	31-62	32-01
Cubic feet of water pumped per second (measured),	152-9	291-2
Displacement of each pump, cubic feet per second	76	76
Temperature of water pumped, degrees F.	81-5	81-5
Weight of water per cubic foot,	62-21	62-21
Useful water H.P.,	547-9	1054
Mechanical efficiency of pumps and engines, per cent.	83-3	82
Boilers (water-tube, Erie City Iron Works, H.P.	1-400	2-400
Steam pressure, gauge,	140	140
Temperature of feed, ° F.	199	199
Boiler H.P., basis 34-5 lbs. of water from and at 212,	434	868
Heating surface of boilers, square feet	3675	7350
Heating surface per boiler H.P., square feet	8-32	8-32
Barometer reading, inches of mercury	29-96	..
Quality of steam, per cent.	99-1	..
Ratio, pounds of water evaporated to pounds of fuel oil, actual,	12-47	..
Ratio water evaporated to fuel oil, from and at 212,	13-14	..
Pounds of oil per minute,	19-03	33-23
*Pounds of fuel oil per I.H.P. hour,	1-736	..
*Pounds of oil per useful water H.P. hour,	2-084	1-892
Heat value of fuel oil, B.T.U.'s per pound	18790	18790
Pounds of steam per I.H.P. hour, used by engines, oil burners, vacuum and feed pumps,	22-02	..
Ratio of heat in steam to that in fuel oil (boiler eff.), per cent.	67-5	..
Cost of fuel to raise 1 million gallons 1 foot, cents	1-81	1-63
Cost of fuel to raise water 20 feet. to irrigate 1 acre 2 feet deep, fuel oil at 50 cents per barrel of 42 U.S.A. gallons,	17-1	15-4
Ratio heat equivalent of W.H.P. to heat equivalent of I.H.P.,	·833	..
Ratio heat equivalent of W.H.P. to heat in fuel oil,	·065	·0716
Duty, per million heat units in fuel, millions of foot-lbs.	50-50	55-7
*Duty per 1,000 lbs. of dry steam, millions of foot-lbs.	75-4	..
Cost per barrel, fuel oil, cents	65	65
Cost of fuel oil per hour,	\$2-36	\$4-12
Amount of water pumped, gallons per minute	68,530	130,700

In the Goldsmidt-Hahlo pump, shown at the left of Fig. 244, there are two crescent-shaped single-lobe rotary displacers C, designed to have the maximum surface contact with the two concave ends of the oval casing A; this pump is consequently adapted for higher pressures than a pump having a pair of double-lobe displacers (if equally well made), but works with a less continuous action,

* From these figures it will be seen that the duty obtainable per 1,000 lbs. of dry steam, if pumps were driven by triple-expansion engines of the highest class, would be nearly 150 millions of foot-lbs.

as there are only two pulsations per revolution instead of four; although in other respects is very similar. The Greindl rotary pump (of French origin and one of the earliest of its kind), shown at the right of Fig. 244, contains a two-winged displacer R, which registers at each half revolution with a recess in the controller drum Q, in a somewhat similar manner to the working of the rotary pump illustrated by Fig. 240, except that in the Greindl pump the controller drum Q is rotated at twice the speed of the displacer drum R, and that the controller drum is partly balanced against water pressure by a recess W in communication with the out'let branch of the casing.

The Enke rotary pump, also of Continental origin, although resembling in principle the preceding examples, comprises one or two structural differences, the most important of which is due to the non-contact method

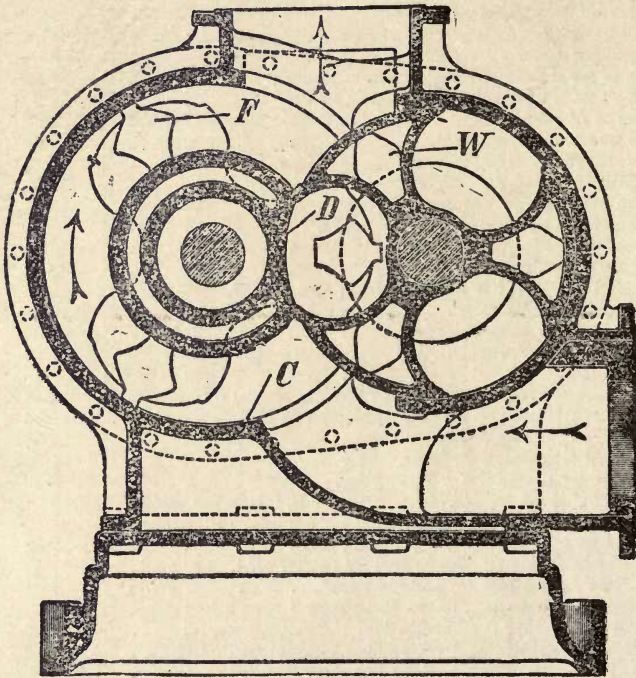

Fig. 244a.—Sectional Elevation of Enke Pump, with a capacity of 200,000 gallons per hour at 60 revolutions per minute, against a head of 75 feet.

of arranging the displacer and controller drums F, W, thereby reducing wear and leakage to a considerable degree. In the Enke pump the rotary displacer consists of a disc provided with three displacer arms F, which are moved round between the inner wall of the casing C and the outer wall of a fixed drum D; this drum is accurately turned, and hollowed out on the side facing the controller drum at D to form a water-tight fit with the three lobes W of the controller drum. The displacer arms F, which are machined to fit accurately between the casing and fixed drum, are carried by a disc at one end which is keyed to the driving shaft, and at the other end of the casing are connected by an annular disc which revolves within a recess in the cover. There is no contact between the displacer arms and the recesses in the controller drum; in fact, there is

quite half an inch of clearance allowed at all points during their passage through the clearance ways. Pumps constructed in accordance with this design have been in successful use, and in considerable sizes too, for many years, and are claimed by the makers to work with a higher efficiency than can possibly be obtained from a centrifugal pump. The illustration is taken from one of an

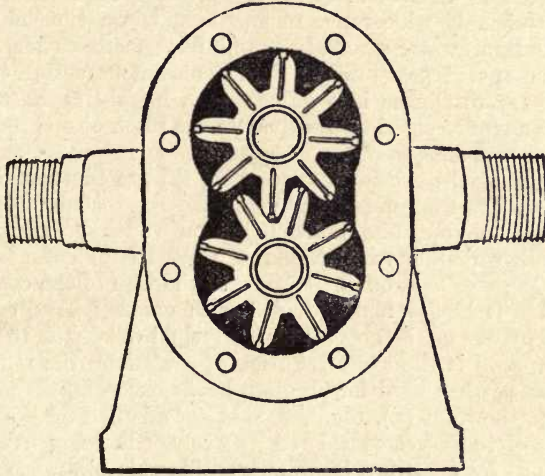

Fig. 245.—Rotary Water-sealed Gear Pump.

installation of three electrically driven pumps, each to deliver over 3,000 gallons per minute at 60 revolutions against a head of 75 feet—*i.e.*, each pump has a capacity equalling 8.4 cubic feet per revolution, and forces against a pressure equal to nearly 40 lbs. per square inch.

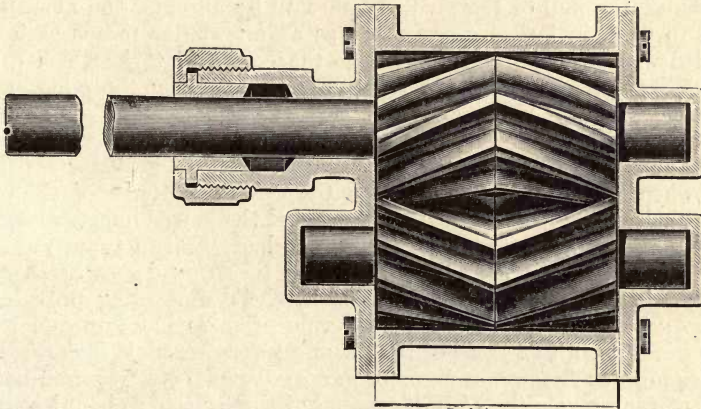

Fig. 246.—Willesten-Albany Double Helical Pump.

The double-revolving displacer drum principle has also been very effectively applied in a rotary pump, known as the wheel or gear pump, and in the illustration (Fig. 245) the duplex displacer wheels are provided with grooves to form a water seal to minimise leakage; this form of rotor piston pump, however, is

capable of forcing against remarkable pressures, and with an almost continuous action when well made and accurately fitted together, and is suitable for outputs ranging from 30 to 1,000 gallons per hour. Another pump of a similar type is shown in sectional plan view by Fig. 246, but is fitted with a pair of helical gear wheels, which are accurately machine-cut and strung together in halves, so that it delivers at an absolutely steady pressure up to 50 lbs. per square inch over a surprisingly wide range of speed, and is a type of pump in considerable demand for water circulation and forced lubrication in automobile motors. In the Fussell gear-pump a more continuous action is obtained by dividing the rotary displacers into halves, each half being fixed on the shaft with an angular advance equal to one-quarter the pitch of one tooth, in relation to the displacer wheel next to it.

Rotary pumps of the eccentric type, class (2) are illustrated by Figs. 247 and 252, of these the first-named is by far the most commonly used, and is made with single, double, and multiple piston vanes P, arranged either as shown—viz., with a double vane extending right through the revolving drum M, or with single vanes held out by springs to the wall of the casing C. In the example the vane is hollow and provided with packing keys, end adjustment being taken up by one of the covers; the principal drawback to this extremely simple form of pump is the excessive friction caused by the movement of the radial sliding vanes when used for pressure heads exceeding 20 feet or so. The Colebrook pump, shown at (L), Fig. 252, is better adapted for liquids containing grit than either of those yet considered, the rollers R being free to roll round in contact with C by centrifugal action, considerable clearance being allowed in the star drum X; the capacity of this type of pump is four times (d) per revolution. In the Oddie pump of this class shown at (B) Fig. 252, an attempt has been made to combine the advantages of the centrifugal pump with the positive action of the rotary pump; in this example a 4-armed drum P revolves eccentrically to the casing C; to the extremities of these arms, vanes W are pivoted each shod with a hinged slipper S, these being held in contact with C and against the pull of the pivoted vanes W by an extension at either side arranged to work in lateral grooves; or, as an alternative means each slipper is provided with a radius arm pivoted at the centre of C, in which case the driving shaft is carried from one side only, thus leaving the opposite cover free for this purpose. Water enters at E in the centre of the pump, the displacement per vane for each revolution being as the difference between the areas of D and (d); this rather novel construction lends itself for satisfactory working when run at a speed at which the centrifugal force of the slippers outwards shall nearly balance the pull inwards of the hinged impeller vanes.

Turning now to the next class (3), we find of the two types represented (Figs. 247 (A), 248, and 249) that both have revolving drums arranged concentrically within casings of equal diameter, the drums being provided with transverse grooves, in which are carried vanes free to move to and fro in a direction parallel with the axis of the drum. In the example illustrated at A, Fig. 247 (known as Lecomptes pump or motor), vanes L are traversed back and forwards at each revolution of K by reason of the helicoidal-shaped covers H; each end of the pump is provided with a separate inlet and outlet, by which means side pressure is balanced. With this construction of pump the same drawback as attached to a pump with a radial sliding vane as shown at R is experienced—viz., the friction due to the movement of the vanes endways along the transverse grooves against the pressure head; in pump (A) there is also a second imperfection as compared with (R)—to wit, the wear on the edges of

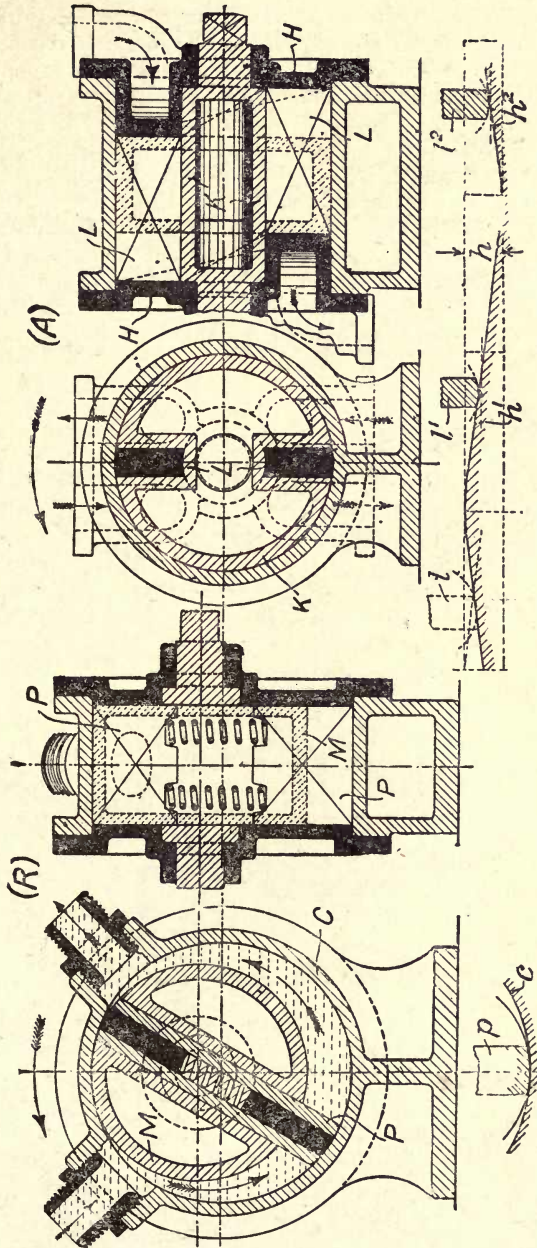

Fig. 247.—Rotary Pumps with Radial and Axial Sliding Pistons

the vane ends at opposite corners at each revolution—the effect of which is exemplified by the developed form of one of the helicoidal actuating covers, in which it will be noted that as the vane (l^1) slides down (h^1), the rear edge is in

contact, this effect being reversed at the opposite side of the cover, as shown at (l^2) against (h^2), when the forward edge is in contact, the difference of the two levels being indicated in dotted lines at (l); on this account the ends of the vanes will require to be formed to a radius accurately proportioned to the depth of (h); in a considerably diminished extent this effect attaches to the radial movement, as indicated by the difference of the radius (p) of M and (c) of C, in consequence of which the ends of the vane P will be alternately exposed to radii varying from (p) to (c) at each revolution.

In the latest development of this class—viz., the Pittler pump (Fig. 248)—in order that the ends of the vanes shall retain as nearly as possible a flat surface, the covers are formed so that there shall be no axial movement while the vanes are exposed to the pressure head. For this purpose the superficies represented by the contact surface of the cover on either side are formed with two flat areas and two sloping areas, such areas on each cover being parallel with one another,

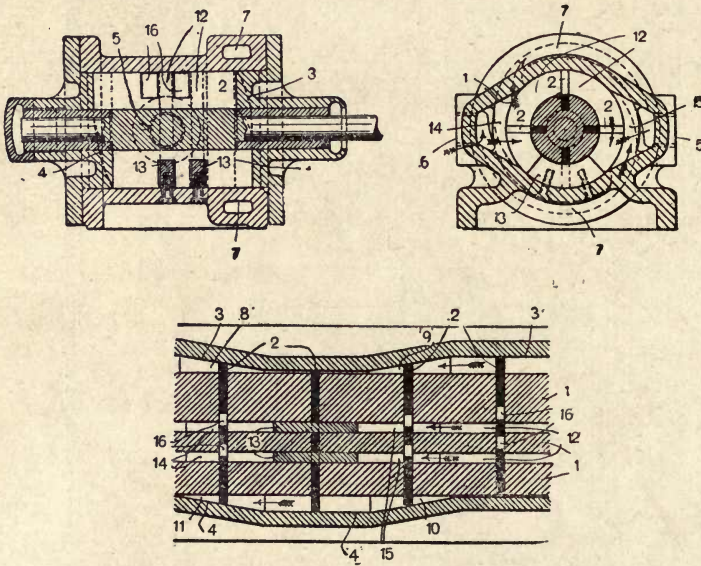

Fig. 248.—Pittler's Reversible Rotary Motor or Pump.

and the portways so arranged that the vanes are only subject to pressure while traversing the flat intervals represented by half the circumference. In the sectional elevations and diagrammatic view illustrating this action, the actuating surface (4) and (3) of the two pump covers is formed so that two of the vanes (2) are simultaneously traversing one quarter of a revolution without any end movement in the direction of the arrows, when liquid will be drawn in through the passages (9) and (10), and forced out through passages (9) and (11). Annular grooves (12) are turned in the revolving drum (1), and "shut-offs" (13), provided as shown, these being secured to the casing and made fluid-tight. On both sides of the "shut-offs" (13) are ports (14) and (15) in communication with passages (7), inlet (6), and outlet (5). Each of the "slides" (2) have openings (16) corresponding to the grooves (12), and register therewith at each revolution and at other times are moved out of range of the grooves, so that

the slides close the grooves. Thus there is always a space in front of the slide approaching the "shut-off" that becomes smaller, and a space in each groove behind the receding slide that becomes larger, following the rotative movement of the slide carrier 1, one side being in continuous communication with the outlet and the other with the inlet or suction pipe. It will be noted that the slide (2) immediately preceding the slide in which the openings (16) are out of register with the grooves (12), is not exposed to any side pressure as the openings (corresponding to 16) are being brought into line with the grooves (12). As this slide advances it will pass over the shut-off (13), the slides following in continuous succession, each slide displacing a space in each groove occupied by one-fourth the circumference. Obviously, a pump of this kind is not limited to the number of displacement grooves, and by the simple expedient of removing one or more of the shut-offs the output of the pump will be correspondingly varied. As this pump is designed for a high speed of rotation, it would seem

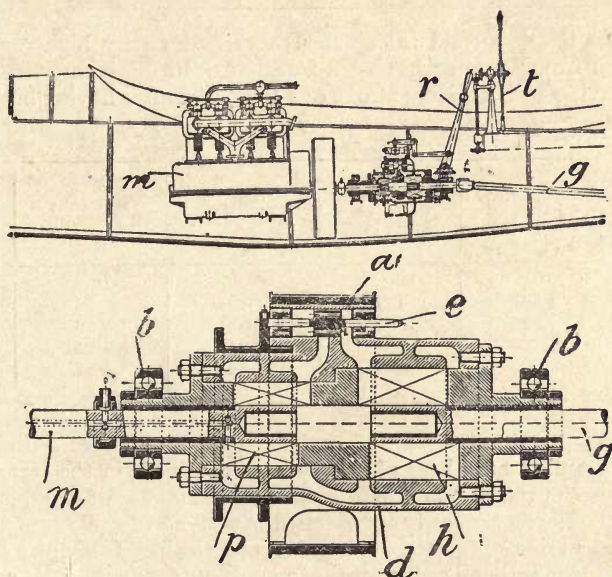

Fig. 249.—Pittler Hydraulic Reversing Gear applied to a Motor-launch.

important that the shuttle movement of the slides should be as graduated as possible, in order to avoid wear and rounding of the slide ends; however, as the fluid pressure is confined to the spaces (12), any slight shortening of the vanes need not, therefore, necessarily be fraught with an inimical influence on the efficiency of the pump.

The Pittler system is equally adaptable to motor or pump, the detailed sectional illustrations at Fig. 249 show a double-acting motor operating with a balanced end thrust with four sliding vanes, in which the end movement is controlled by the two cam-shaped covers, while the slides run successively in a state of balance, thus avoiding frictional loss that would occur if this sliding action were continued over the periods while under pressure. The following figures tabulated from tests on a pump and motor of this type, demonstrate the practicability of running at high speeds with a surprising mechanical

efficiency for apparatus of so remarkably diminutive size ; for example, a pump having a double-acting rotating drum 4 inches diameter, with four sliding vanes, each $1\frac{3}{8}$ inches long by $\frac{1}{32}$ inch thick, stroke $\frac{9}{16}$ inch, and a volumetric capacity of 8 cubic inches per revolution, developed results as below :—

Revolutions per minute.	Quantity of Oil Pumped in gallons per hour.	Pressure Head in lbs. per square inch.	Brake Horse-power.	Hydraulic Horse-power.
520	910	1.2	.53	0.12
525	915	75	1.27	0.8
520	875	150	2.14	1.5
520	890	150	2.15	1.54
515	895	225	3.15	2.33

The results in the second table show capacity for very high pressures, and were obtained from a motor having a rotating drum $6\frac{7}{8}$ inches diameter, with four vanes having each a sliding stroke of 1 inch, and after having been in service for five months :—

Revolutions per minute.	Quantity of Oil Pumped in gallons per hour.	Pressure Head in lbs. per square inch.	Brake Horse-power.	Hydraulic Horse-power.	Mechanical Efficiency per cent.
121	1,344	172	2.1	2.66	79
126	1,322	243	3.06	3.66	86
120	1,280	360	3.94	4.74	85
115	1,230	405	4.64	5.58	87

In addition to the wide field of usefulness for a compact self-starting and reversible hydraulic transmitter of this type as obtaining in the transmission of power for those purposes wherewith motors of the 3- and 4-cylinder Brotherhood, Rigg, Hastie, and other types are used (*e.g.*, for hydraulic control of heavy weights, such as bridges, turrets, guns, gates, and the like), may also be included power transmission from oil and petrol automobile motors with some considerable show of reason, recognising its comparatively small size and weight, as an indication of which the application illustrated by Fig. 249 is a very practical example. With this combined reversing gear and clutch, when it is desired to go ahead, the casing (*d*) containing a drum and series of pump vanes (*p*) and motor drum and vanes (*h*), is locked hydraulically by the reversing valve (*e*) by interrupting the circulation of oil from (*p*) to (*h*), and in this manner causes the casing (*d*) and drum (*h*) to rotate solidly with the drum (*p*), which is connected direct to the motor (*m*), and in consequence of this the propeller shaft (*g*) is then driven as a coupled unit with the entire gear ; as the casing will now revolve in ball bearings (*b*), and, further, as no oil is pumped, the loss of efficiency in the transmission is limited to a slight leakage around and between the two drums (*p*) and (*h*). For changing over to go-astern the valve (*e*) is reversed and the brake (*a*) applied, thus holding casing (*d*) and causing pump (*p*) to circulate oil through the ports leading to and from (*e*) to the motor drum (*h*), when the propeller shaft (*g*) will be caused to revolve in the reverse direction, and on releasing

the brake with the valve (*e*) open, the propeller shaft will stop, the gear at all times working in absolute silence.

In both pumps and motors on this system compensation for wear and prevention of leakage between the sliding vanes and casing is automatically provided for in both a radial and axial direction, the former by reason of the vanes being forced outwards against the circular wall of the casing by centrifugal action, and the latter by hydraulic pressure; these lateral action vanes for this purpose are divided lengthways, the two halves of each vane interlocking and caused to be held apart by means of the interspaces between the vane ends being placed in communication with the pressure side of the transmitter; the vanes can thus separately accommodate themselves to any inexactitude in the parallelism of the actuating cam formation at either side, or for any solid matter carried through with the liquid, and so reduce the possibility of leakage under high pressures to practically vanishing point. In connection with this system of hydraulic transmission there is another feature of considerable importance not yet commented upon—to wit, the total absence of packing boxes and glands, this circumstance accounting in some measure for the successful working at very high speeds and pressures of this useful combined motor and pump.

There are quite a variety of rotary valveless pumps that may be included under Class 4, of which it may be with some justice stated in many cases that ingenuity takes precedence over other considerations. The examples, however, adduced under this category are really practical serviceable pumps, for if any attempt had been made to describe in the merest outline all the rotative combinations that have been promulgated for this purpose as much space again would necessarily be required as already occupied on this subject. Referring first to the Lamplough pulsator pump, illustrated by the sectional views (Fig. 250) and photo view with cover removed (Fig. 251), we find a fork-shaped rotor *F*

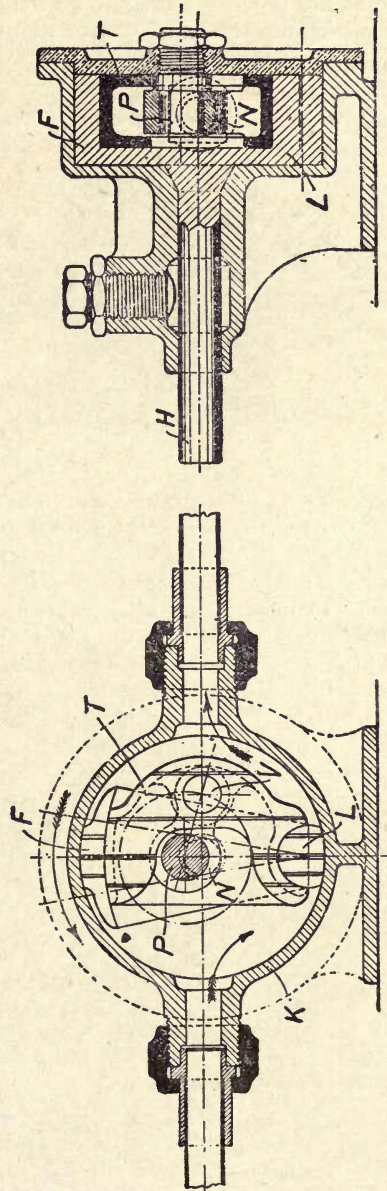

Fig. 250.—Sectional Elevations of Albany Positive Rotary Pump. Lamplough's Patent.

arranged to revolve concentrically within the casing K by the driving shaft H. One prong of the fork takes the form of a pivot L, from which as a radius the opposite prong is bored to receive a pulsating piston T, which derives its movement from the link N connecting the pulsator at V to a pin P carried by the front cover eccentrically to the centre of the casing; in consequence of this, as the fork F revolves, an oscillatory movement of T will be set up, which (if rotated in the direction indicated by the arrow) will cause T to approach the right and recede from the left until F has closed the inlet and L the outlet, a further half turn causing a corresponding displacement on the reverse side of T; pumps with 3 to 5 inches diameter connections are capable of throwing from 4,000 to 12,000 gallons per hour at 130 revolutions with an equable flow. Its action is, needless to say, reversible as a pump, and even as a motor will start from any position, and may be said to somewhat resemble the movements of a trapezist in doing a somersault, P corresponding to the bar and L to the swing seat. In an extended trial this pump shows very little signs of wear, the bearing surface being systematically grooved on all sides of both revolving elements.

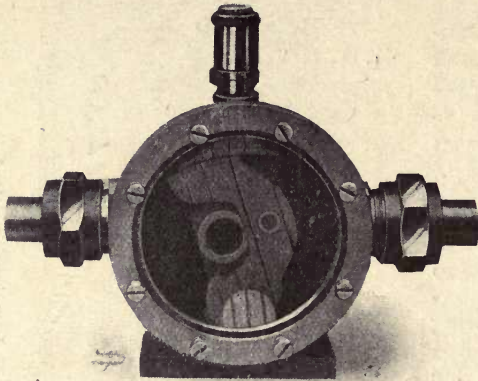

Fig. 251.—Lamplough-Albany Positive Rotary Pump, with Cover removed, showing Revolving Shuttle Action Displacer.

even as a motor will start from any position, and may be said to somewhat resemble the movements of a trapezist in doing a somersault, P corresponding to the bar and L to the swing seat. In an extended trial this pump shows very little signs of wear, the bearing surface being systematically grooved on all sides of both revolving elements.

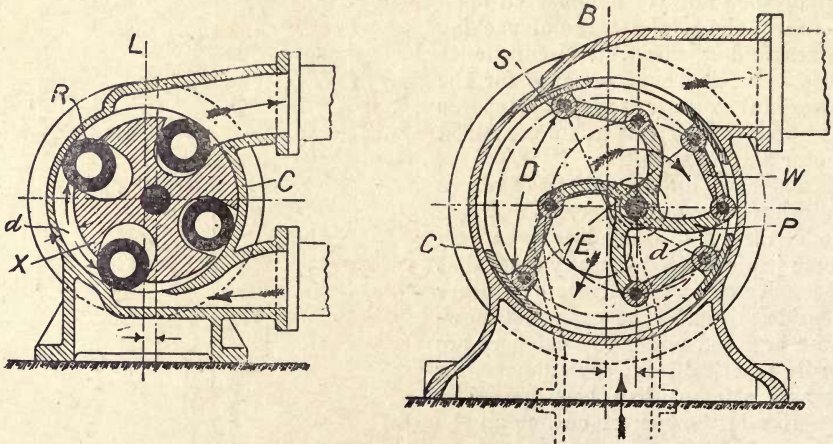

Fig. 252.—Cross-sectional Elevations of the Colebrook and Oddie Rotary Pumps.

In the Lane-Eland rotary pump, illustrated by the sectional and perspective views (Fig. 253), an almost continuous rate of flow is obtained by the oscillation of three vanes (*w*) pivoted at one end to bearings in the outer casing (*k*), and

at their inner ends to slippers (*a*) held up to the eccentric drum (*e*) by side rings not shown. The drum (*e*) is hollow and divided by a partition, one side communicating with the inlet at (*s*), and the other with the outlet at (*d*) through the hollow shaft (*h*). On the face of the drum (*e*) are two openings extending each about one-third round the rim of the drum; one of these (*d*) communicates with the delivery end, and the other (*s*) with the suction pipe. In action the rotation of (*e*) as indicated displaces the contents of the space enclosed by the vanes (*w*) and (*w*¹) through (*d*), a continued rotatory movement of (*e*) next displacing the space enclosed by (*w*¹) and (*w*²) also through (*d*), a further movement emptying space within (*w*¹) and (*w*), this completing one revolution; simultaneously, water will be drawn in through (*s*) to the vane enclosed spaces as each in succession is extended by the movement of the drum, the slippers (*a*) acting as distributing valves to the two openings on the outer face of (*e*) during the respiratory movement of the pump. The capacity of the Eland pump is much greater than can be obtained from any combination of plungers when arranged within similar dimensions, this advantage being strikingly evidenced in a portable Eland fire engine, which, although entirely self-contained, with petrol motor and travelling wheels, only weighs complete for action 5 cwts., the pump being capable of throwing 100 gallons 100 feet high per minute, which represents 4 P.H.P., including hose and jet resistance (the motor being rated at 6 B.H.P.), there is, therefore, not much margin for mechanical friction, even when taking into account the absence of packing glands; the internal diameter of the drum shaft in this fire pump is 4 inches, which dimension reduces the velocity of flow to within 4 feet per second, the port openings communicating with the three displacer vanes being of a proportionately large area.

A third modification coming under Class 4 is represented by the perspective view (Fig. 254), this being a full-size illustration of a "half-inch" Lamplough-Albany rotary pump, having a capacity of 300 gallons per hour at 450 revolutions, and suitable for forced lubrication and a number of other purposes wherewith valveless positive action pumps, ranging in capacity from 40 to 1,200 gallons per hour, and capable of discharging against pressure heads up to 200 feet, can be employed. From the illustration (with cover removed) it will be seen that this pump comprises in all but five parts—viz., an eccentric forming part of the driving shaft, a circular piston, an

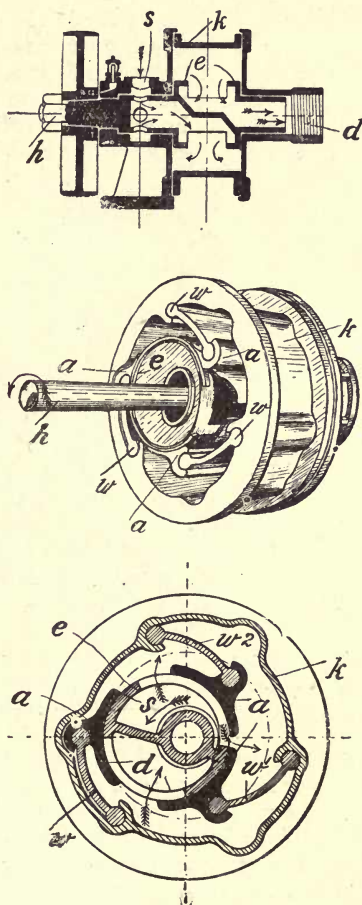

Fig. 253.—Sectional and Perspective Views of Lane-Eland Rotary Pump.

oscillating valve cradle, the outer casing, and two covers. In the position shown the piston is at half-stroke, one side delivering and the other drawing in a fresh charge. When the eccentric is in the opposite position to that shown in the engraving, the piston will be resting in its cradle, and will then close both delivery and suction ports situated on each side of the piston tongue piece; and the whole space above the piston at that time will be filled with liquid ready for delivery during the succeeding revolution, suction and delivery continuing with but slight interruption throughout the circular course of the piston.

In common with most rotary pumps, no provision in the Lamplough is feasible for taking up wear in the displacer mechanism; in consequence of this peculiarity this and other pumps of the kind are not adapted for liquids containing abrasive material, the only exceptions to this rule being the Colebrook, Oddie, and Lane-Eland, wear in the two former being automatically compensated for circumferentially by centrifugal action, and in the latter by hydraulic pressure.

In the table on page 351 will be found much useful information and data

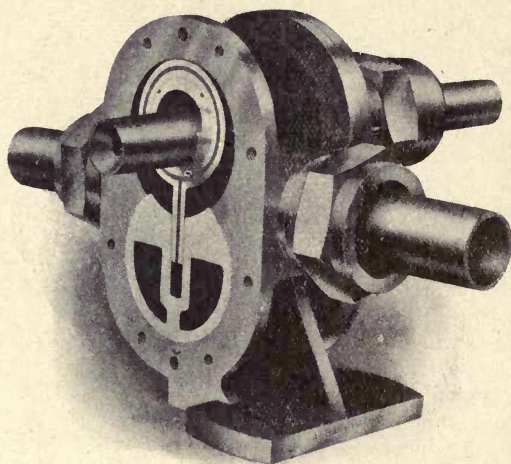

Fig. 254.—Lamplough-Albany Rotary Pump, with Eccentric Action Displacer.

respecting the usefulness of the several forms of valveless positive action (rotary, chain, and archimedean) pumps above described, and a few examples of wing, diaphragm, and plunger pumps of the portable type and adapted for manual power.

There is yet another type of valveless rotary pump to be considered; in this fifth class,* in which may be included the Hele-Shaw pump, illustrated by Figs. 232 and 232a, also the Vincent, better known as the roto-plunge pump, the displacement is effected by a ring of plungers caused to rotate about a centre eccentric to that of the pump casing. The first

named of these has been already described as a variable and reversible flow pump or motor, and will not require further explanation other than to point out that the ram plungers M are caused to revolve within a circle by the ring R and slippers S, which is capable of being moved away from the centre of the outer casing G to either side by the connection E, thus causing the seven plungers M to move radially to and fro in the seven revolving barrels B, and for the suction and discharge to be controlled by slotways on the fixed bearing shaft communicating with the openings P and Q extending to either side of the pump, each of which, as before explained, can serve for either suction or delivery, according to the position of the inner controlling ring.

In the Vincent roto-plunge pump, illustrated by Fig. 255, instead of the plungers (*p*) being arranged to communicate with suction and discharge openings at the centre, as in the pump just described, the construction of the Vincent pump is such that the plungers draw in their charge of liquid while traversing

* The Carey ball piston rotary transmitter should also be included in this category.

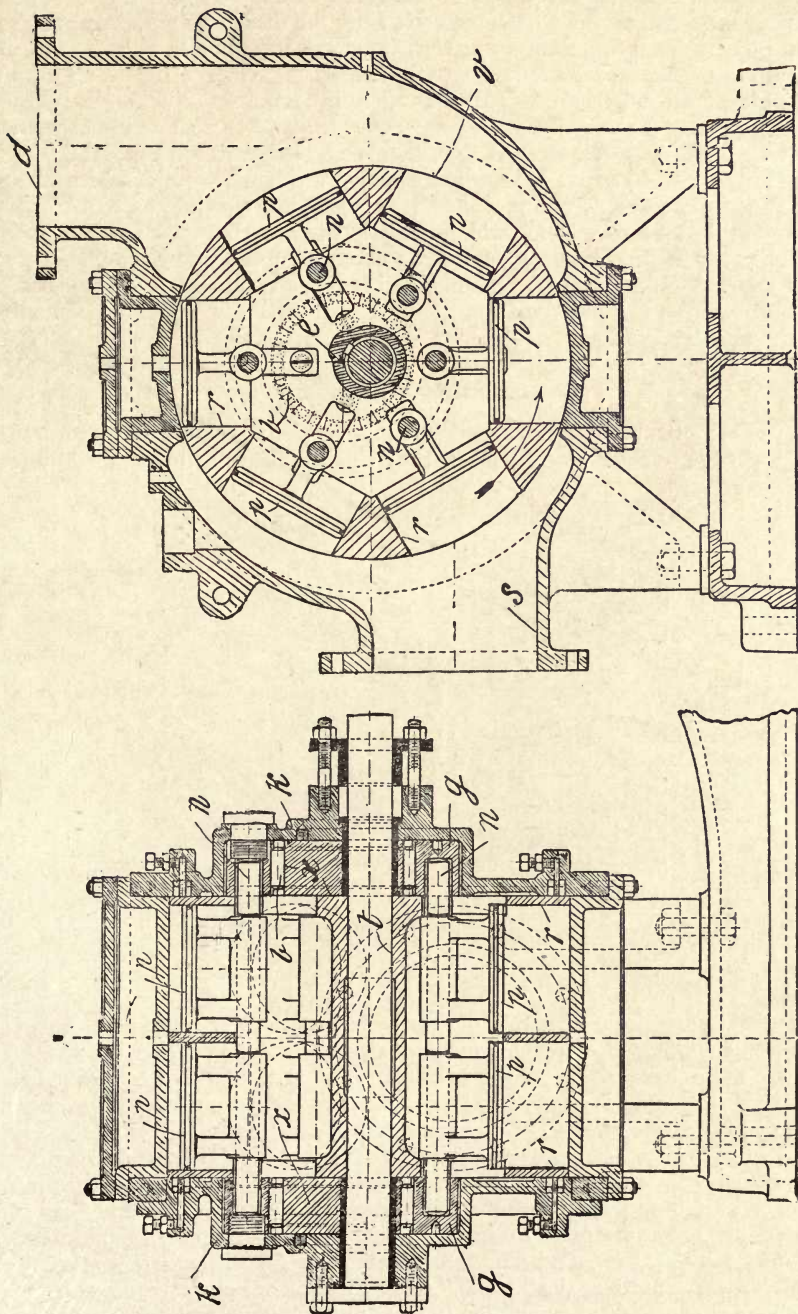

Fig. 255.—Sectional Elevations of the Vincent Rotoplunge Pump.

the suction chamber (*s*) contained in the outer casing (*v*), and deliver while traversing the chamber (*d*) on the opposite side, the discharge with the number of plungers shown being practically continuous. The double ring of twelve plungers are constrained to follow a path about the centre (*e*) by the bars (*n*) (to which they are connected in pairs), as these in turn are carried at their ends by the rings (*g*), which revolve about eccentric sheaves (*x*) with a ring of rollers (*b*) between. The twelve-barrelled star chamber (*r*) is keyed to the driving shaft (*t*) running in gland-packed bearings carried by the end covers (*k*). An interesting feature about this pump, which is, of course, reversible as a motor, is its adaptability as a clutch, for which purpose the outer chamber, constituting the driving member, forms an annulus surrounding the star-barrel chamber (*r*), except at one point, where communication is controlled by a valve, which, when open, allows a free circulation of the liquid, and when closed effectually locks the clutch.

Oscillating Pumps.

Of these most useful pumps, the oscillating piston-vane type, known as "wing" pumps, are the most compact, the overall dimensions for manual power

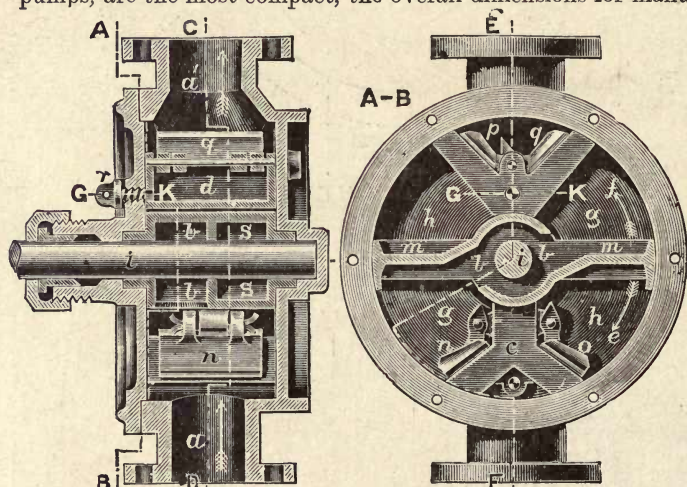

Fig. 256.—Wilcox Quadruple Action Wing Pump (Abrahamson's Patent).

pumps of this description capable of raising from 3 to 100 gallons per minute not exceeding 3.5 inches for the smallest size and 18 inches for the largest. There are several makes of wing pumps, but the most effective is the Wilcox quadruplex illustrated in section by Fig. 256, this variety differing from others in having four displacement chambers instead of two, which effect is obtained by the use of a piston (*m*) provided with transverse passages (*s*) and (*b*), which in action, on being oscillated in the direction (*e*), draws liquid through (*n*) into the chambers (*g*), and simultaneously discharges the contents of chambers (*h*) through (*v*). On the piston (*m*) being oscillated in the direction (*f*), liquid enters at (*o*), fills chambers (*h*), and empties the chamber (*g*) through the valve (*q*). In another make, known as the "Delta," ordinary clack or ball valves are arranged in chambers at each side of a partition (*t*), *vide* Fig. 257, and works with a double-acting discharge by the oscillation of the wing (*v*), in which renewable rubber

packing keys are fitted as shown. There is also a horizontal variety, known as the "Arma," shown to the left of the figure. In this pump double pistons

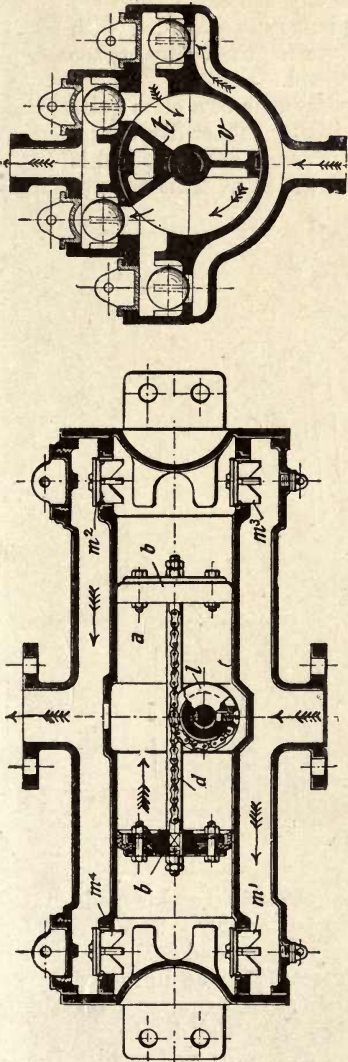

Fig. 257.—Sectional Elevations of the Arma and Delta Double-acting Oscillating Pumps.

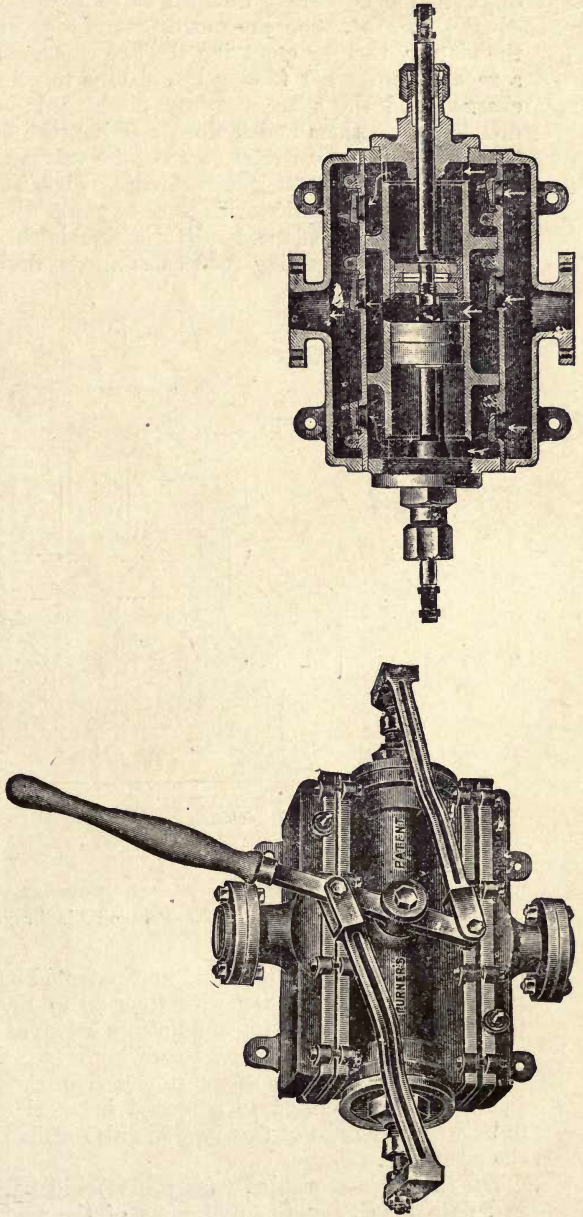

Fig. 258.—Turner-Wilcox Triple-action Plunger Pump.

(b) are connected by two chains (d) to sprockets (l), the action being clearly explained by the arrows; the space (a) is open to the delivery passage and the circular pistons are packed by cup leathers held in place by junk rings.

The Wilcox-Turner pump shown at Fig. 258 is remarkable in being triple-acting, the space between the two pistons being utilised so that the capacity of the pump is thereby doubled as compared with one of the Arma make of equal size. In action the movement of the handle in one direction separates the pistons, thereby emptying the two end spaces and filling the central space; a reverse movement forcing the pistons together, whereby the end spaces are charged and the space between discharged; each plunger is provided with double cup leathers and is double-acting, the flap valves for the central space having double the waterway area of the valves at either end.

The diaphragm pump illustrated by Figs. 259 is an example of a class quite unique in its application, this form of pump with the circular rubber diaphragm displacer M being adapted for thick liquids charged with mud and grit, and is much used for emptying road excavations, drains, and the like. This type of

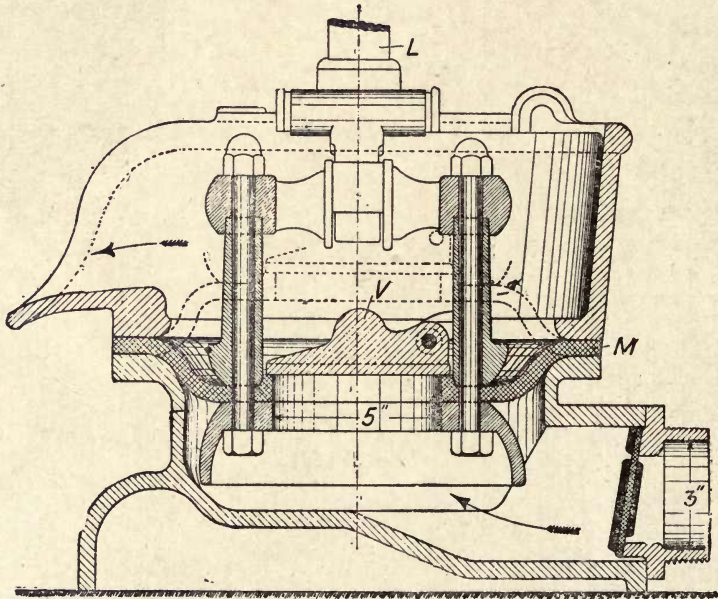

Fig. 259.—Paragon Diaphragm Pump.

pump is of American origin, and first patented by Edson, of Boston, and is made in sizes capable of dealing with from 20 to 100 gallons per minute. The diaphragm is held between top and bottom halves of the pump casing, and connected to the lever L by a crosshead carrying a flap valve V seated on an upturned flange to the inner edge of the rubber ring, the upper cup-shaped ring carrying the valve being bolted to a second inverted cup below with the diaphragm in between; pumps of this type are also made closed in at top, as well as with the open lip, as shown.

In the table appended (*vide* p. 351) will be found much useful information and data respecting the usefulness of the several forms of valveless positive action (rotary, chain, and archimedean) pumps above described, as well as a few examples of wing, diaphragm, and plunger pumps of the portable type, such as are adapted for manual power.

Wind-power Pumping Engines.

The increasing popularity of small wind-driven pumps is due to the introduction of the multiple-vaned wheel and automatic governing in combination with light, easily-erected steel towers; in these the average power developed in comparison with that obtained from steam, gas, and oil-driven pumps is very low, and ranges from 1 to 6 H.P. or so, on a wind velocity of 15 miles per hour (22 feet per second), a 20-mile wind doubling this power, and a 10-mile wind generating about half the power obtained by a 15-mile wind; and in ordinary practice it may be stated that the pumping capacity of a wind engine as expressed in pounds of water raised per minute by pressure head in feet, rarely exceeds from 25 to 35 per cent. of the wheel horse-power. The location of a wind pump is generally influenced more by the available water supply than from any consideration of available wind power, the tower usually being carried up to clear all obstacles around for a distance of 300 to 400 feet; and as under normal conditions eight hours pumping can only generally be relied upon as a daily average, to make an installation successful a storage tank or reservoir should be provided, the minimum capacity of which may with advantage equal from four to seven days' pumping although a larger reserve is often provided for.

Ordinary single and double-acting as well as bucket and plunger pumps may be used in this connection, the plungers deriving their motion by a spear rod either connected to a crank or rack transmission; the ratio of pump stroke to revolutions of wind wheel may vary considerably—for instance, in six different makes of wind pumps, each having a 16-foot diameter wheel, one is a single-acting pump geared $2\frac{1}{2}$ to 1, with plunger 4 by 8 inches; two pumps are double-acting, one with a plunger $3\frac{1}{2}$ by 5 inches, geared 2 to 1, and the other $2\frac{1}{2}$ by 8 inches, geared 1 to 1; two have bucket and plunger pumps, one 6 inches stroke and ratio to wheel 1 to 1, and the other 8 inches, and ratio 2 to 1, each of these five being crank driven; the sixth pump is fitted with a rack and pinion movement direct connected to a double-acting plunger of 4 inches diameter, to which a stroke ratio of 5 to 1—viz., 22 inches—is imparted. In regard to the working of the long stroke rack-gear drive there is found to be a considerable advantage over any ratio of crank transmission, the former developing nearly twice the power obtained by the latter under identical conditions of wheel diameter and height of tower; the explanation for this result is not due to any peculiarity in the construction of the pump itself, but entirely to the plunger being actuated at a constant velocity during the complete up and down strokes; with a crank drive, on the contrary, either the plunger speed must vary from a maximum to a minimum twice each revolution, or be modified by a cyclic fluctuation in the velocity of the wheel of considerable degree, an effect more clearly noticeable with wind velocities falling below 15 feet per second, under which conditions the wheel of a crank-driven pump (especially when single-acting or without reducing gear) may be observed to lag at each pump stroke.

In order to establish reliable data as to the working of wind-pumping engines of all types, the Royal Agricultural Society carried out in the spring of 1903 at Park Royal a carefully conducted series of trials continued over several weeks, with wind velocities varying from 3 to 33 feet per second, on 19 engines of 17 different makes, and ranging in size from an 8-foot to a 30-foot diameter wheel, these including two 8-foot wheels, six 12-foot wheels, seven 16-foot wheels, three 20-foot and one 30-foot wheel; the comparative working of which is shown in the accompanying tables:—

TABLE A SHOWING PERFORMANCES OF WIND PUMPING ENGINES IN R.A.S.E. TRIALS, SHOWING QUANTITY IN IMPERIAL GALLONS PUMPED AGAINST A TOTAL HEAD OF 200 FEET, AS REGISTERED BY METER, PER DAY OF 10 HOURS.

Average Wind Velocity in miles per hour for each day.	Results of Two Engines with 8 ft. diameter wheels.		Results of Six Engines with 12 ft. diameter wheels.		Results of Seven Engines with 16 ft. diameter wheels.		Results of Three Engines with 20 ft. diameter wheels.		Result of Engine with 30 ft. diameter wheel.	
	Highest.	Lowest.	Highest.	Lowest.	Highest.	Lowest.	Highest.	Lowest.	Highest.	Lowest.
5	650	320	1,200	350	940	..
8	1,500	900	3,000	600	1,600	800	4,000	..
10	2,000	950	4,000	1,600	3,500	1,200	7,000	..
12	2,400	1,000	4,200	2,000	4,100	3,800	8,000	..
15	400	..	4,000	1,250	5,600	3,750	6,000	4,000	13,000	..
18	700	..	3,500	1,700	5,200	4,500	19,000	..
20	900	700	4,200	1,400	6,930	4,200	21,000	..
22	800	..	4,500	1,500	7,600	3,300	23,000	..
24	4,950	1,600	10,400	3,600	24,000	..
CORRECTED AVERAGE CAPACITY IN GALLONS PER HOUR RAISED 50 FEET.										
15	250	1,000	1,500	2,200	5,000					

TABLES B AND C SHOWING THE WORKING OF THE SIX SELECTED WIND PUMPING ENGINES DURING THE FINAL R.A.S.E. TRIALS OF 150 HOURS.

Name of Engine.	Diameter of Wheel in Feet.	Total Quantity Pumped in Thousands of Gallons.	Total Pressure Head in Feet.	Total Revolutions of Wheel in Thousands.	Total Number of Double Strokes of Pump in Thousands.
Canadian-Imperial, . . .	16	79	200	308	42
Henry Sykes, Ltd., . . .	16	49	200	210	210
J. W. Titt,	16	46	200	285	285
Thomas & Son,	16	41	200	307	122
R. Warner & Co.,	16	40	200	330	160
J. W. Titt,	16	36	200	230	88

Ratio of Wheel to Pump.	Particulars of Pumps.					Transmission.		Average Water Horse-Power per Minu'e.
	Diameter in Inches.	Stroke in Inches.	Single Acting.	Double-Acting.	Bucket and Plunger.	Crank.	Rack.	
5	4	22	..	*	*	·53
1	2·5	8	..	*	..	*	..	·33
1	3·25	6·12	*	*	..	·30
2·5	4	8	*	*	..	·275
2	3·5	5	..	*	..	*	..	·268
2·5	4·5	8	*	*	..	·242

In the first table there will be noted some discrepancies, it being extremely difficult to determine the exact average of wind velocity extending over the length of time the engines were under trial; the results obtained in the water-raising capacity combined with other advantages of the six pumps included in the second table were considered to be superior to all others excepting the pump with the 30-foot wheel, this engine exceeding the limits of size. On examination of the results obtained in the final trials it will be noted that the long-stroke rack-transmission engine indicates an advantage over the next best (which also has a long stroke—viz., 3·2 to 1) of 62 per cent., and an increased capacity of 88 per cent. over the mean output of the five crank-driven pumps.

The mechanism and general arrangement of the Canadian Imperial wind pump is illustrated at Fig. 260, in which (*w*) is the boss carrying the wheel vanes, consisting of 18 blades grouped in six sections, having a driving area of 130 square feet, and a wind-clearance area equal to 68 square feet, in addition to about 31 square feet represented by the area of the wheel centre, the length of the blades being 5 feet. The wheel shaft runs in swivelled roller bearings (*b*), carried by the revolving frame (*f*), in turn supported on conical rollers (*l*) situated over the turntable section of the tower (*t*). Keyed to the driving shaft is a pinion (*n*) cast with cams (*k*), between which is carried the mangle rack (*q*), forming the head of the pump spear rod (*p*). In action the rack (*q*) is held in position for the up and down strokes by the friction runners (*r*) and guide rail (*g*), the rack guide rail traversing upwards inside the runners, and when

at the top of its stroke will be moved over into position for the down stroke by the rollers (*m*) and cams (*k*), the opposite side of the rack then engaging with the pinion (*n*), thus each single stroke is performed in 0.4 of 5 revolutions of the pinion at an equal velocity; at the end of each second revolution an idle half-turn of the driving pinion carries the rack over into position for two more power revolutions at a uniform torque, therein lying the advantage of the rack drive over the crank, the weight or flywheel effect of the wind wheel being insufficient to maintain an equal angular velocity with either a geared or directly connected crank transmission with moderate wind velocities.

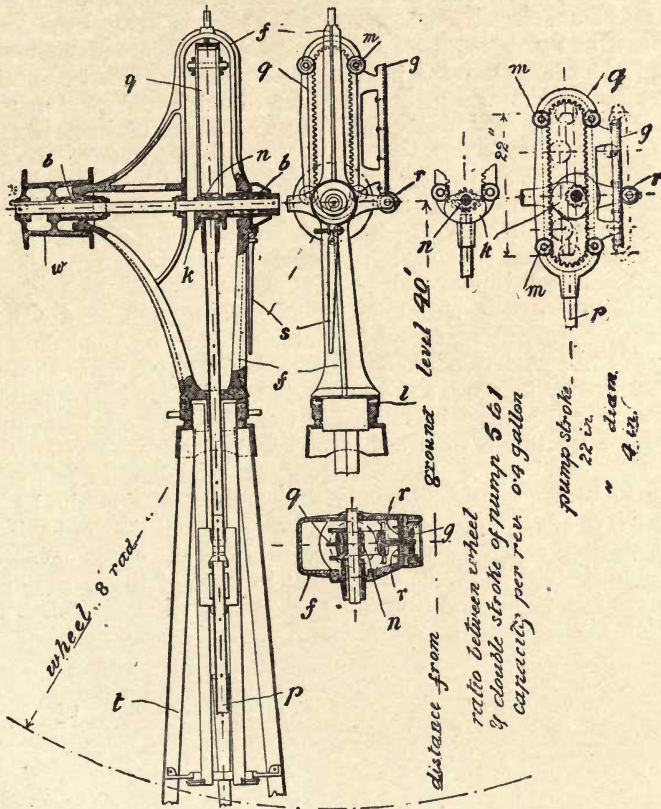

Fig. 260.—Details of Driving Gear of Canadian Imperial, 22 × 4 Inches, Double-acting Wind Pump.

In a wind engine the next important consideration is the means used for governing, the method usually employed being to turn the wheel away from the wind by a rudder when its force exceeds a determined limit, which is very effectively performed in the Canadian wind engine by means of a spring and tail vane controlled turntable carried on the conical rollers (*l*), the action of which is such as to turn the wheel partly out of the wind on being struck by a strong gust, the spring pulling the wheel back again face to the wind as soon as the pressure relaxes. On releasing the tension of the controlling spring

by a wire and lever connection at the base of the tower the spring pulls the wheel and tail vane into line with one another, and consequently the wheel is held edge on to the wind, the same movement applying the brake (s); to start, the turntable has to be pulled round to face the wind. The advantage of this method is obvious, as in the event of the controlling gear going wrong, or of the wheel being overtaken by a hurricane, the wheel automatically goes out of the wind and stops. Another governing method and one principally used in wind engines having a large wheel diameter, consists in arranging the vanes or sails in such manner that increased wind pressure can force back the following edge of the vane—*i.e.*, decrease the pitch and thereby reduce the speed of the wheel.

For long before the advent of steam, wind engines have served a most useful purpose, and in many countries too, many wind mills and pumps—centuries old—being still in existence and in localities as remote as Siberia. Their principal use, apart from corn-milling, has been for draining and pumping, for which purposes a great number are still to be met with in the lowlands of East Anglia, Holland, and elsewhere. But owing to the very limited power obtainable from wind in localities where it is most required, even with the most scientifically constructed wheels, wind engines cannot compete with steam, gas, or oil engines, except for quite small powers such as can be profitably applied for pumping—*e.g.*, the average actual water horse-power of a wind pump having a wheel diameter of 16 feet does not much exceed half-horse for the highest and quarter-horse for the lowest, with a 15 mile per hour wind; and for a wheel diameter of 30 feet, the power as expressed by water that can be lifted does not exceed from 1.25 to 1.75 actual W.H.P.; and although the power that can be developed with a 20-mile wind increases some 50 per cent., it rapidly falls off with a reduced wind velocity, a 10-mile wind reducing the power to one-half, and explains the reason for locating a wind engine on as high and exposed an eminence as possible, when required for other purposes than pumping.

In regard to the construction and arrangement of the wheel vanes, there is no real power advantage with multiple vanes, except that of having a greater torque at starting and for slow running, owing to the effect of interference or overlap; and, indeed, it will be found that in most of the larger wind engines having a span of 40 feet, and upwards, across the sails, the Dutch four-armed construction with variable pitch still continues to be used.

CHAPTER XVIII.

LOW-LIFT AND HIGH-LIFT CENTRIFUGAL PUMPS.

Single-Stage Volute Low-Lift Pumps.

For land drainage, irrigation, and other purposes wherewith large volumes of water have to be lifted to comparatively low heads of from 4 to 12 feet, as required, for instance, in the draining of low-lands in Holland and other countries, and nearer home in the Fen district, known as the Bedford Level, norias or scoop wheels were until quite recently the principal pumping apparatus in use. The

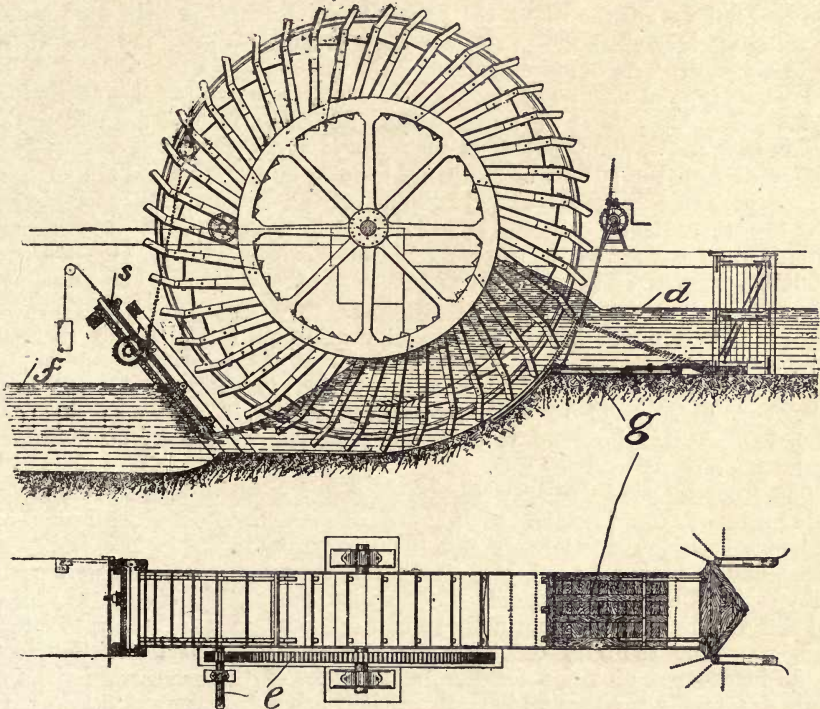

Fig. 261.—30 by 5 Feet Scoop-wheel Pump. Capacity, 5 tons per Second against head of 5 to 6 feet.

norias wheel illustrated by Fig. 261 represents a pump of this kind in its latest and most advanced form, particulars of which are:—Outer diameter 30 feet, length of scoop 6 feet 6 inches, width 5 feet, angle of scoops 25° , increasing to 29° at the outer edge; the capacity of such a pump at 5 revolutions per minute

—*i.e.*, with a circumferential velocity of 7·8 feet per second—is 11,000 cubic feet or 300 tons per minute against an average head of 5 feet. In good practice a norias pump is arranged to work in a race extending forward some 33°, and the water in its passage to the wheel is controlled by a sluice gate (*s*), by which means the flow of water at the level (*f*) towards the wheel is prevented from coming into contact with the vanes until a point near the centre is reached, thus avoiding loss of power from downward impact; the object also for arranging the vanes at an angle as shown is so that the water will quickly run off at the delivery end, and thus avoid loss that would result from any water being carried over the wheel; some advantage is also obtained by raising the tail sluice at (*g*), by which means the action of the wheel is rendered freer, the angle being determined by the difference of levels (*f*) and (*d*) in their relation to the diameter and speed at which the wheel is driven. The energy represented by the water flow from under the sluice gate (*s*) is not lost, the action being similar to that obtained in the Poncelet water wheel to be referred to later—the work, therefore, done by the wheel is as the difference of the levels (*f*) and (*d*) plus friction, the efficiency of the lift apart from the drive varying from 65 to 75 per cent., according to the proportion of wheel diameter to the difference of level at the head and tail ends of the wheel, the larger the diameter, neglecting wind resistance, the more efficient the pump, a 6 to 1 proportion being the most usual practice, and the form of drive as shown at (*e*).

Another type of low-lift pump formerly extensively used in this connection but now, as in the case of the norias, fallen into disuse, may be mentioned, the archimedean screw, many pumps of this type of considerable size having been superseded with the advent of steam by Cornish and other pumping engines. The largest, and also the most recent, pumps of this very ancient type were set up at Katatbah, Egypt, so recently as 1881; but in this case, however, were soon destined to be replaced by the more economical centrifugal pump. This immense installation consisted originally of 10 archimedean pumps, each set being designed to raise 50,000 gallons—*i.e.*, 22·3 tons of water per revolution—which at 6 revolutions per minute equals 8,000 tons per hour against a total head of 12 feet, and represents 109 W.H.P. per screw. Each of these “Easton-Anderson” archimedean pumps consisted of a tube 11 feet diameter by 43 feet long, inclined at an angle of 12° with the horizontal, the 10 sets being arranged parallel to one another, and to draw from a basin of 150 by 50 feet communicating directly with the Nile.

Some considerable difficulty was soon experienced with the working of these mammoth contrivances, owing in a great measure to deflection caused by the immense weight of water carried in the tube; from this, therefore, and other causes, and in part due to their general inefficiency, seven of them were eventually replaced by vertical centrifugal “Farcot” pumps, which were the largest and first centrifugal pumps put down to be worked by a vertical shaft. Trouble again was from the very onset experienced with the new installation, due to the inadequate provision for the great weight of the impeller, shaft, and flywheel, totalling together 50 tons, this weight being carried by a water-cooled bearing (*b*) with forced lubrication, supported by the fixed shaft (*t*) (*vide* Fig. 262).

Thus at this installation seven of the discarded screw pumps were replaced by five centrifugal pumps of the type referred to, the other three archimedean being put into working order and retained as a stand-by, the total capacity of the combined plant being then equivalent to 1,500 W.H.P., the capacity of each of the Farcot pumps being equal to a discharge of 77,000 gallons per

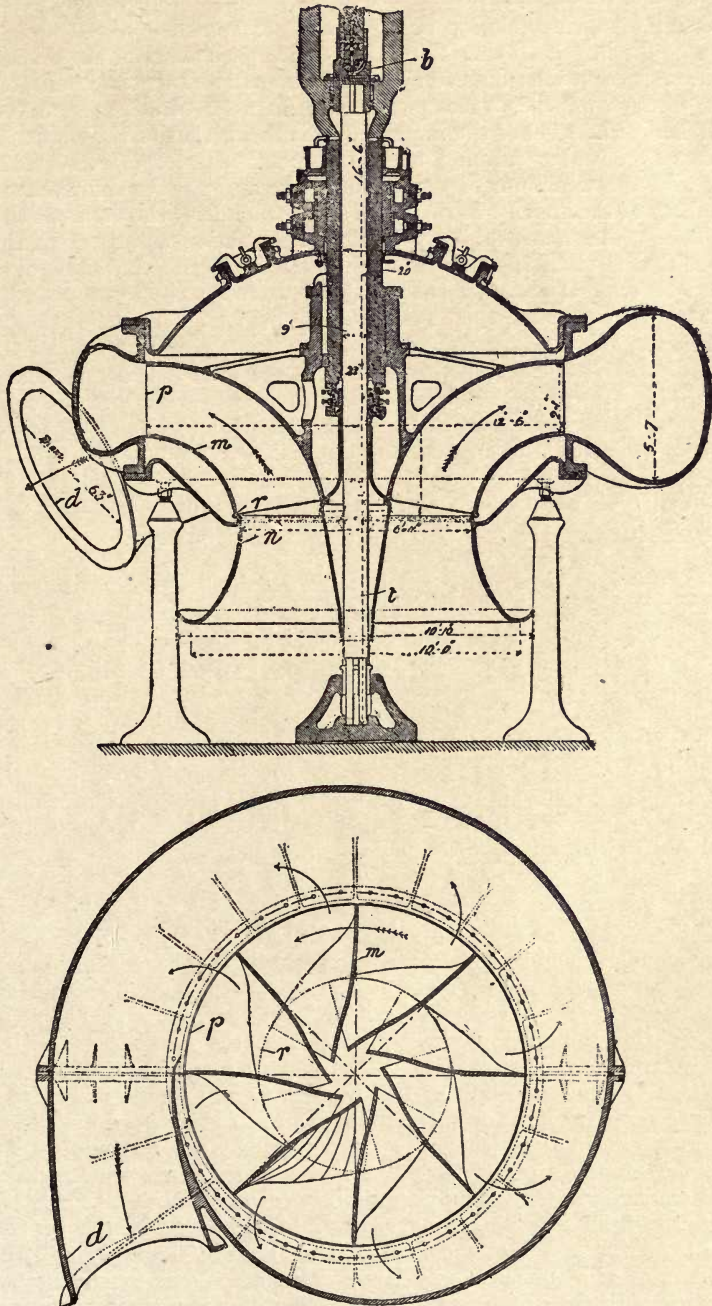

Fig. 262.—Farcot Vertical Centrifugal Irrigation Pump. Capacity, 6 tons per second, raised 10 feet.

minute, against a total head of 10 feet at a speed of 32 revolutions per minute—*i.e.*, equal to a rim velocity of 20.8 feet per second—= $0.82 \sqrt{2gh}$, the diameter of the impeller being 12.5 feet. Other particulars of these interesting pumps are: suction inlet diameter 82 inches at narrowest point, radial velocity of water through impeller 6 feet per second, diameter of outlet from volute at (*d*) 63 inches. The level of the impeller (*m*) is below that of the suction supply at all times, the water entering by a bell-mouthed inlet (*n*), direct into the impeller with the minimum of suction lift; the angle of the eight vanes (*m*) to the periphery of the impeller at (*p*) is 90° , and the angle of the vanes at the inner rim (*r*) is 60° , the vanes taking a helicoidal formation as shown in the plan section, so that in effect the pump combines to some degree the action of a screw as well as centrifugal impeller. Some diminution also in the resistance to the radial flow through the impeller is obtained by the conoidal form of the impeller discs, with the result of an overall efficiency being obtained equal to 65 per cent., as between the water horse-power and the indicated horse-power—*viz.*, 230 W.H.P. and 350 I.H.P.—the pumps in each case being directly connected to a single-cylinder Corliss engine, 39.3 inches diameter by 71 inches stroke. In this connection it is interesting to add that Allis-Chalmers vertical pumps of almost identical type to this have been supplied in considerable number for drainage work, one in Chicago having a capacity of two tons per second, which pump is driven by a Corliss-Chalmers engine having three cylinders at 120° , each connected to one crank.

The following particulars of a Sulzer irrigation plant at Khoderat (Upper Egypt) are of sufficient interest to be mentioned here, which plant comprises two sets of direct-connected tandem compound horizontal engines of 15.75 and 27.5 inches diameter by 47.5 inches stroke, and two centrifugal volute pumps, having each an impeller 88.5 inches diameter, revolving with a peripheral velocity of 42 feet per second—*viz.*, at 110 revolutions per minute. The capacity of each of these pumps is 176 tons per minute, against a head of 29 feet, and is equivalent to a water horse-power of 350, the indicated horse-power of the engines in each case being approximately 500, showing an efficiency of 70 per cent. The diameter of suction inlets for each pump is 35.5 inches, and the delivery orifice 50 inches, with a velocity of flow through the pump equivalent to 7.5 feet per second, and, through the delivery pipe, 8.5 feet per second, the volume pumped being 660 gallons per second, and the rim velocity equivalent approximately to $0.9 \sqrt{2gh}$, as against a value of 0.82 in the Farcot pumps.

Many examples could be adduced in demonstration of the extreme importance of the centrifugal pump as an instrument for the reclamation and drainage of various lowlands in Egypt, Italy, Holland, and elsewhere; one firm alone having supplied centrifugal pumping plants for each of the countries named, that, taken collectively, would aggregate to a volume equal to some 140 tons per minute downwards to small portable units of from 1 to 5 tons per minute capacity. The following example will suffice to illustrate what can be done by a plant of 3 tons per minute capacity:—On an estate at Kenton, near London, such a plant is available for irrigating purposes in drouthy seasons, that is capable of distributing from a neighbouring brook through a 6-inch hose water equivalent to a rainfall of 7 inches over 3 acres of land in the space of 12 hours. The possibilities of a comparatively larger plant are shown to greater purpose in connection with the drainage and reclamation of a territory known as Lake Aboukir (Egypt), comprising an area of 31,000 acres; this plant comprising two sets of 48-inch "Invincible" centrifugal pumps, as illustrated by Fig. 263,

each capable of raising 200 tons 10 feet high per minute, and capable of draining this extensive area dry in 456 hours. This plant has now, however, after four

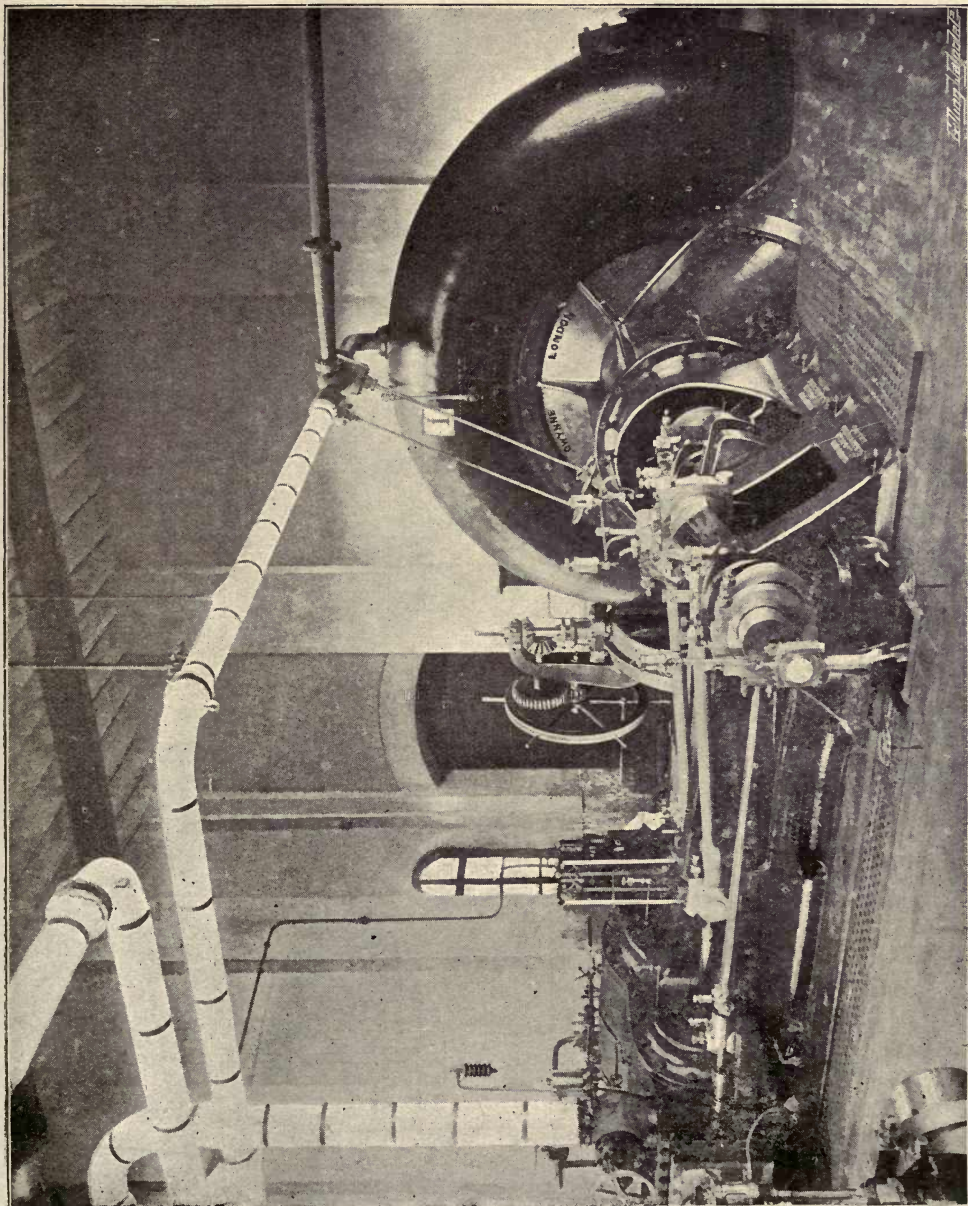

Fig. 263.—One of a pair of "Invincible," Gwynne 48-inch Centrifugal Direct-coupled Pumps installed at Mex for the Reclamation of Lake Aboukir. Capacity, 400 tons per minute, 10 feet high.

years' service, been removed and reinstalled at Mex, near Alexandria, on the borders of Lake Mareotis, which is 9 feet below sea level, and sufficiently below

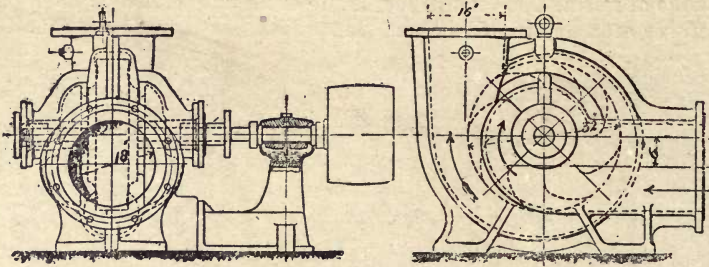

Fig. 264 —Ruston-Proctor Belt-driven Irrigation Pump, showing Special Form of Suction Branch.

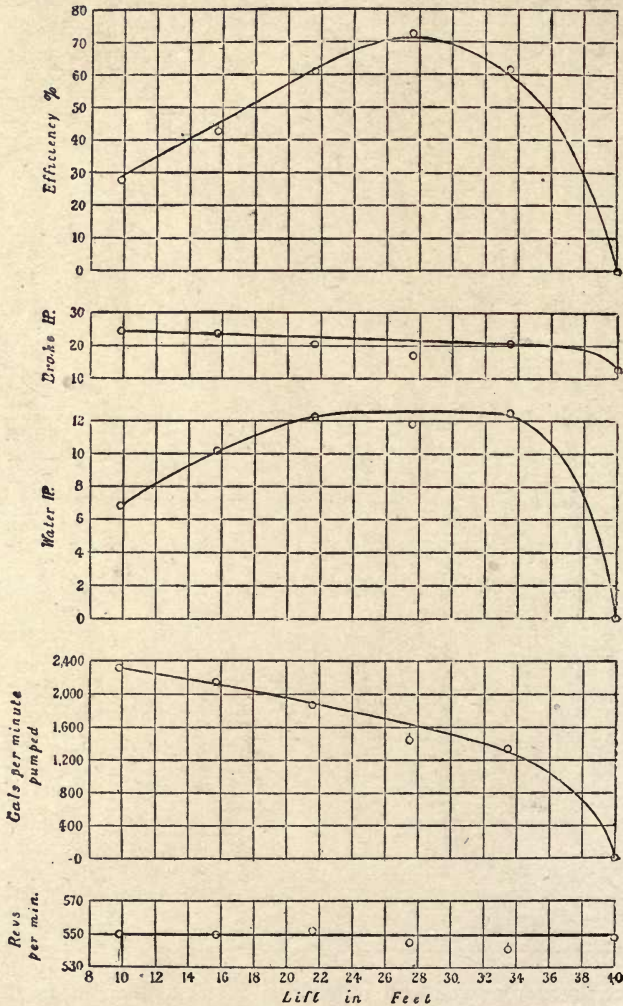

Fig. 265 —Diagrams showing effect of varying Head to Output in 8-inch Centrifugal Pump at Constant Speed.

the adjacent reclaimed area for that to be drained simultaneously with the new territory by this same plant, water from the already-drained area automatically draining into the latter, and it is noteworthy to add that both areas are now under cultivation.

The belt-driven irrigation pump shown at Fig. 264 represents a type of centrifugal in which the inlet branch is arranged out of centre with the impeller, the inflow thus meeting the impeller vanes with the minimum of shock, in furtherance of which purpose the suction area is from 20 to 25 per cent. larger than usual practice. Two pumps with 36-inch discharge branches and impellers 72 inches diameter, supplied by this firm to Baliana on the Nile, being capable each of delivering 150 tons per minute against a head of 27·5 feet with an overall efficiency of 66 per cent., and, as shown below, efficiencies of 75 per cent. or even higher are possible with such pumps when worked under the most favourable conditions.

In this connection it will be remembered that one of a set of four cycloidal direct-driven rotary pumps put down in Louisiana for irrigation purposes was described in the preceding chapter (*vide* Fig. 243), in which plant (now being

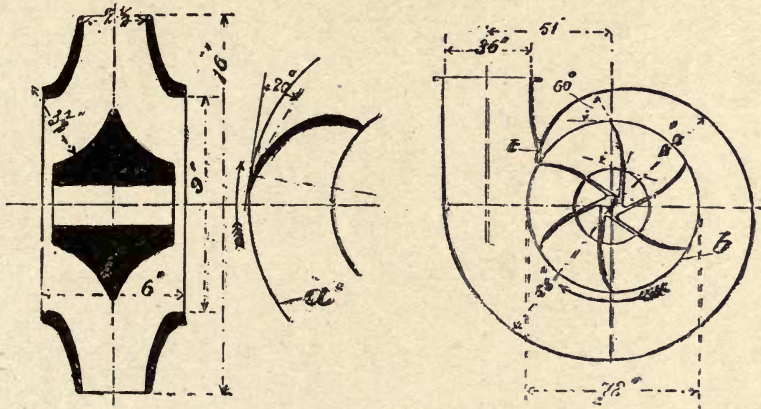

Fig. 266.—Impellers used in Ruston-Proctor Irrigation Pumps.

doubled) a volume of water equivalent to over 8 tons per second—*i.e.*, 480 tons per minute—is raised 31·5 to 32 feet, thus representing over 1,000 water horsepower—*i.e.*, 1,043—the most extraordinary feature about this plant consists, not only in the fact of rotary pumps being used, but that such highly economical results can be obtained, considering that with the exception of specially-formed cycloidal-shaped rotor lobes and the provision of large air-expansion chambers on the suction and discharge ends, these pumps do not materially differ from others of this type—to wit, during a carefully-conducted test extending over a period of 10 hours with two engines and pumps, 548 W.H.P. was developed on an I.H.P. of 657; and with four engines and pumps running 1,054 W.H.P. for an I.H.P. of 1,320, which shows a combined overall efficiency over both pumps and engines of 80 per cent., which is higher than has ever been obtained in a centrifugal pump, even without taking the engine into account, the pumps must, therefore, have an efficiency of over 90 per cent. for this to be possible.

Another purpose for which low-lift centrifugal pumps are eminently adapted is the emptying of docks, this being a field of usefulness in which this class of

pump has prominently identified itself, and of which the illustration (Fig. 267) is a fairly representative example, this consisting, as in plants, for a much larger output, of a compound vertical condensing engine directly coupled to a pump of the type shown. In this particular plant there are duplicate sets of 45-inch centrifugal pumps, each fitted with an impeller of the enclosed type, 7 feet 6 inches diameter, and capable of delivering 30,000 gallons per minute—*i.e.*, a volume exceeding 2 tons per second—one of the largest plants of the “Conqueror” make—*viz.*, equal to an output of 450 tons per minute for each pump—having been installed at the New South Dock at Cardiff, which pumps are provided with double-suction branches, 42 inches diameter, and a discharge branch of 60 inches diameter, and in other respects conform to the general construction shown in Fig. 267. In this connection there is in addition to the actual pumping capacity, the time required to get to work, this consideration applying more

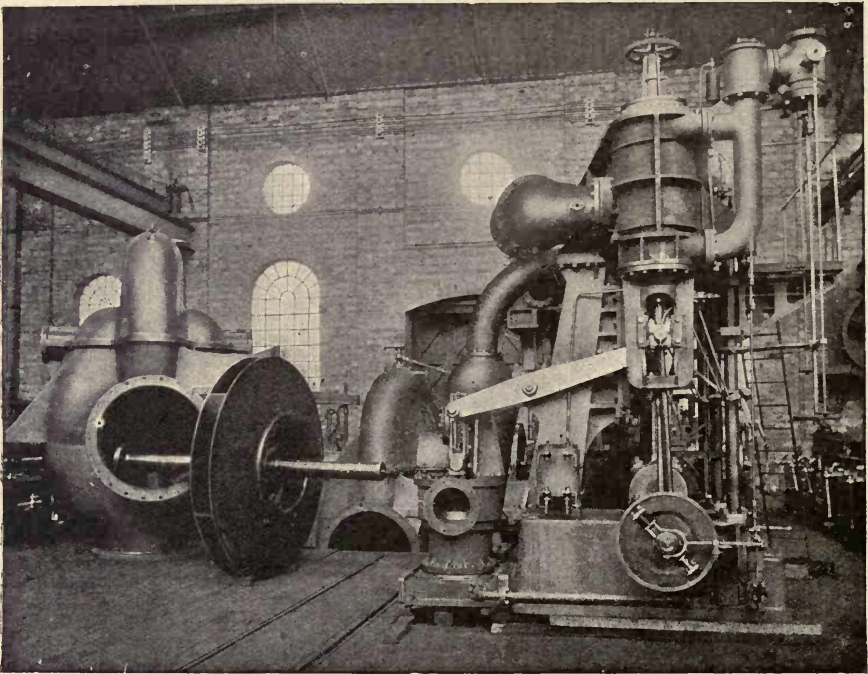

Fig. 267.—Two 45-inch “Conqueror” Centrifugal Pumps, each driven by a 500 B.H.P. Engine with Jet Condensing Plant. Supplied to the Mersey Docks and Harbour Board for Herculaneum Dock, Liverpool. Capacity of each pump, 140 tons per minute.

pertinently to the emptying of graving docks than to any other purpose requiring pumping machinery of great capacity. With steam this involves banked fires in the boilers, and with gas power, banked fires in the producers; but with oil power, all that is necessary is that a supply of compressed air be held in readiness. Taking this into consideration the Mersey Dock and Harbour Board have selected Diesel oil engines for their latest dock, the “Gladstone,” now under construction. This dock, which is intended to accommodate the very largest class of vessels, will have a greater capacity than any other graving

dock in the world, and will have an immersed capacity equal to seven millions of cubic feet, which it is required to discharge in $2\frac{1}{2}$ hours from a head varying from nil to 48-52 feet at the finish of the operation. For this purpose five Worthington centrifugal pumps are to be installed, each having a discharge

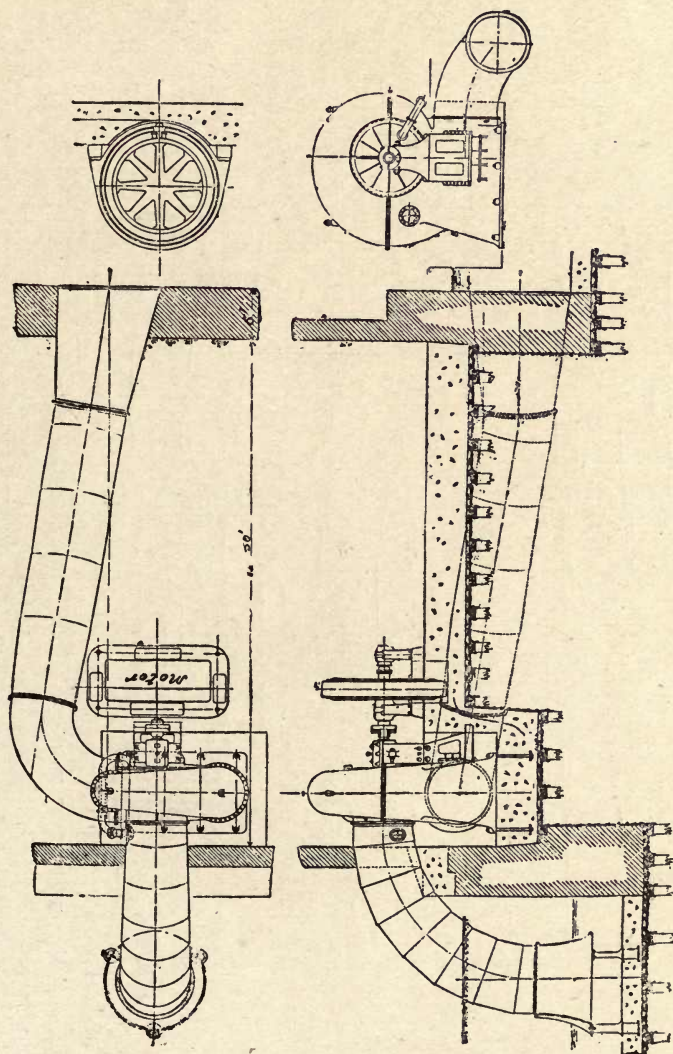

Fig. 268.—Arrangement of Electrically-driven Horizontal Drainage Pump. Capacity, 400 tons per minute.

of 54 inches diameter, and two suction inlets of 40 inches diameter. Each pump is to be coupled direct to a 4-cylinder two-cycle vertical Diesel oil engine capable of developing 1,000 brake horse-power; by this means it is expected to be able to get all running at full power in less than a quarter of an hour, and without any stand-by expense.

Another important application of centrifugal pumps and one for which they are peculiarly adapted—owing to their ability for great capacity at low-pressure heads—is that of town-drainage work, and in this connection are illustrated (Figs. 268 and 269) two arrangements of town-drainage plant recently put down in New Orleans, U.S.A., the first of which consists of two Morriss centri-

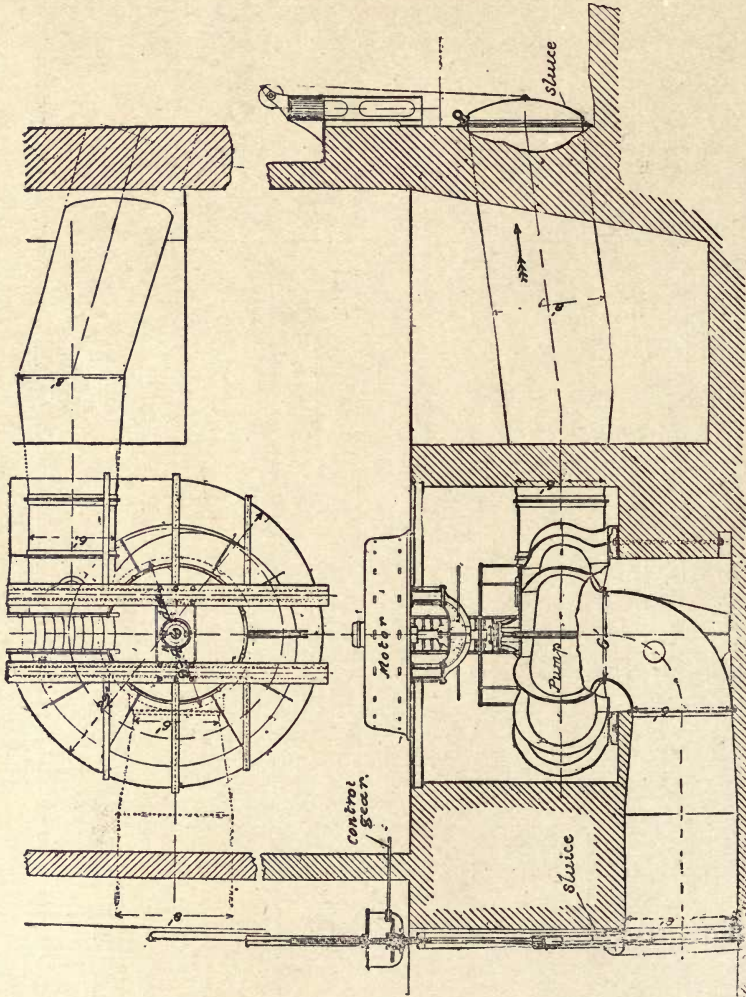

Fig. 269.—Arrangement of Electrically-driven Vertical Drainage Pump. Capacity, 500 tons per minute.

fugal pumps (horizontal type) of a capacity each of 400 tons per minute, against a normal head of 8 feet, under which conditions an efficiency of 60 per cent. is guaranteed for the combined working of each 250 kw. alternating-current motor and pump. One peculiarity in these pumps and of some economic value, consists in the taper construction of both suction and discharge pipes, by which means the velocity at the foot of the suction pipe is reduced to 5 feet per second,

rising to 9 feet per second; and the velocity of discharge in the delivery pipe is caused to fall from 10 feet per second to 3 feet per second, thus effecting a saving of nearly 20 W.H.P. in the total of 230 W.H.P., by utilising the kinetic energy represented by the difference of 7 tons flowing from 10 to 3 feet per second, this effect being obtained by enlarging the pipe from 6 to 10 feet diameter at the discharge basin.

In the large vertical, electrically-driven drainage pump (Fig. 269), one of four of the same make for another station in New Orleans, the diameter of the impeller is 9 feet 4 inches, and developed on test an efficiency of 74 per cent. when lifting 500 tons per minute against a head of 10 feet, the output falling to 455 tons per minute, against a head of 11 feet, with an increased efficiency, however, of 3 per cent., thus bringing it up to 77 per cent.; in these, as in the horizontal pumps, both suction and discharge pipes are tapered, and in both cases the range of lift varies according to the season from a maximum of 15 feet to a minimum of 3 feet. The proportionate gain obtained by reducing the discharge velocity will be, therefore, greatest at the lower lifts, and is then nearly 40 W.H.P. in the horizontal pumps and 50 W.H.P. in the vertical pumps, as, for instance, when drawing from a 3-foot lift, allowing for a discharge velocity of 20 feet per second, this advantage falling off to a little under 16 and 20 W.H.P. respectively at the 15-foot lift, and obviously, although of practical significance for lifts under 10 feet, the gain will ultimately disappear with an increasing lift. Apropos to this:—The three large centrifugal pumps now being installed at the New Graving Dock, Belfast, with $3\frac{1}{2}$ millions of cubic feet capacity, which it is required to empty in 100 minutes, are fitted with delivery pipes tapering from 54 to 60 inches, thus reducing the outflow velocity 25 per cent. below that at the delivery end of the pumps.

Centrifugal pumps are also used with great advantage and very extensively in connection with dredging operations. The principal requirements in pumps for this purpose are the provision of specially thick volutes and impellers, as well as means to prevent the intrusion of sand to the bearings, this being a consideration obviously of the greatest importance. For river beds where vegetable or stringy matter is encountered, impeller wheels of the open type, such as illustrated by Fig. 273, and by the elevation (a) in Fig. 274, are sometimes used; but for sandy deposits an enclosed disc impeller with extra thick vanes, as shown by the elevation (b), is preferred by several makers. In the "Edwards" pump, specially constructed for this purpose, and illustrated by Fig. 270, this difficulty is met by the employment of detachable sections N to the vanes M carried by shrouded discs L; the volute chamber B is also constructed of great thickness, where, subject to the wearing action of the sand, the circumferential portion being cast separate from the frame and sides, and of diminished size, in order to keep down weight and to facilitate renewal. This pump, known as the "Cataract," in common with usual American practice, has only one suction inlet C, this construction rendering not only a freer inlet, but also lends itself to easy dismantling of the impeller by the removal of the suction flange D, the covers at each side of the impeller being provided with renewable liners as shown. Intrusion of sand to the bearing G is prevented by the packing ring U, beside which the shaft gland is further protected by a hydraulic box O. The shaft H is extended at the driving end, where it is carried by two journals between which runs the driving pulley shown in Fig. 272; any unbalanced end thrust on the impeller is resisted by a thrust bearing carried by an adjustable yoke.

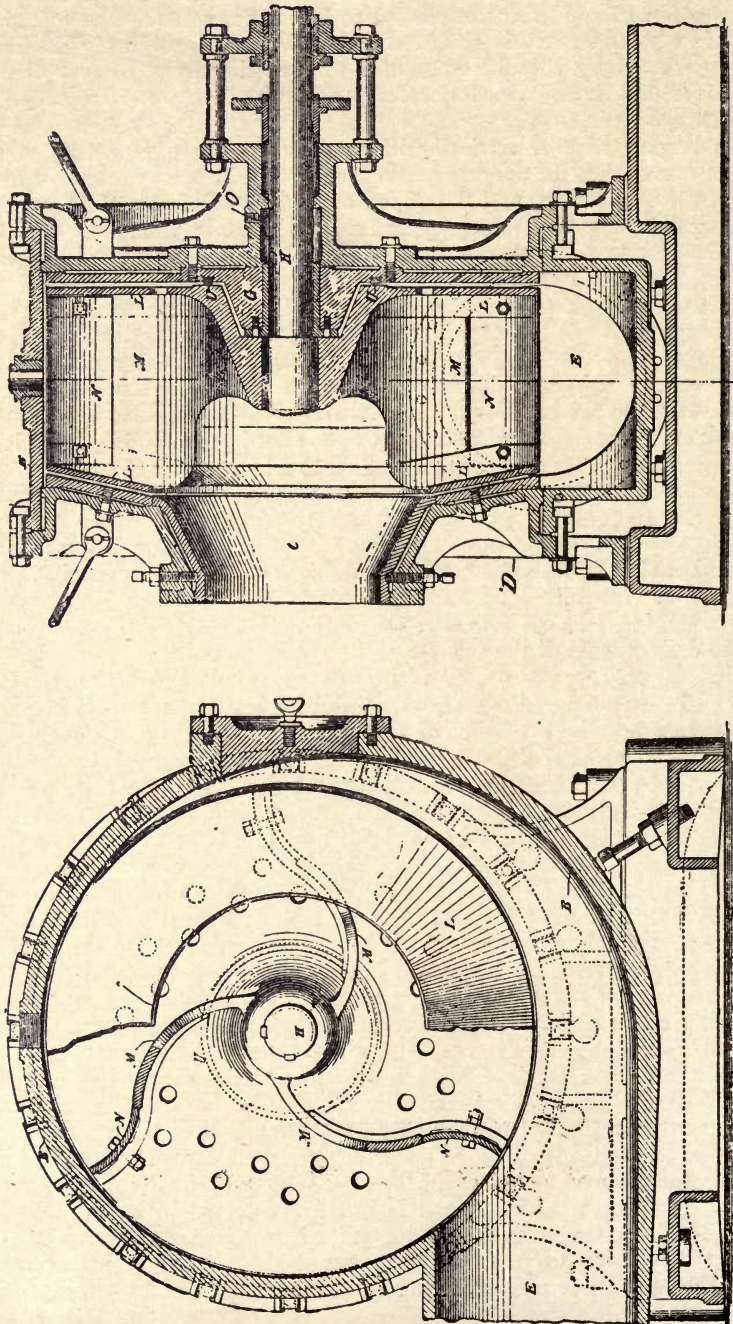

Fig. 270.—Sectional Elevations of Edwards "Cataract" Dredging Pump, showing Arrangement of Renewable Vanes.

The dredging steamer illustrated by Figs. 271 and 272 represents clearly the arrangement of suction pipes B, suckers C, and lifting tackle E for a double set of belt-driven 15-inch centrifugal pumps of the kind described; this example is taken from one of the three dredgers used in the deepening of New York Harbour, having a carrying capacity of 650 cubic yards in the six settling bins shown, each of which are provided with side and bottom sluice gates. The overall length of this steamer is 157 feet, beam 37 feet, and depth of hold, 16 feet; the average time occupied in pumping a load is from 45 to 50 minutes (*i.e.*, 12 cubic yards per minute) from an average depth of from 25 to 35 feet, and to a height above water level of from 10 to 15 feet. In operation on a round trip of 20 miles for dumping each load, from six to eight loads can be pumped in one day, the total quantity estimated to have been excavated in the five years of dredging operations amounting to over 5,000,000 cubic yards. The

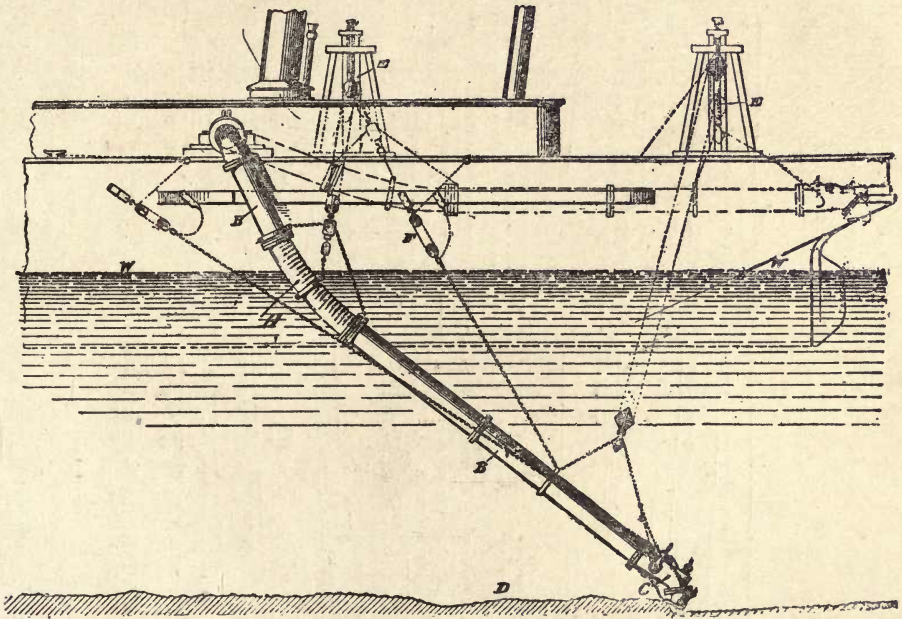

Fig. 271.—Arrangement of Suction Pipe on Dredging Steamer, showing Flexible Connection.

suction pipes B are each provided with a flexible section of rubber hose H of about 12 feet in length located a few feet from the elbow, in order that the pipes can accommodate themselves to the pitching and rolling motion of the steamer; the vertical and lateral control of these pipes, each 60 feet long and 15 inches diameter, is supported by the triple sets of chain and block tackles E. As soon as the bins are filled the suction pipes are hoisted out of the water and the steamer headed straight away for the dumping ground; in other cases the dredger works in co-operation with a service of dumping scows and tugs. In regard to the power required for working a dredger pump of this make, it may be said that a 10-inch pump will remove 135 cubic yards of material per hour mixed with 850 per cent. of water on about 25 H.P. per each 10 feet of total

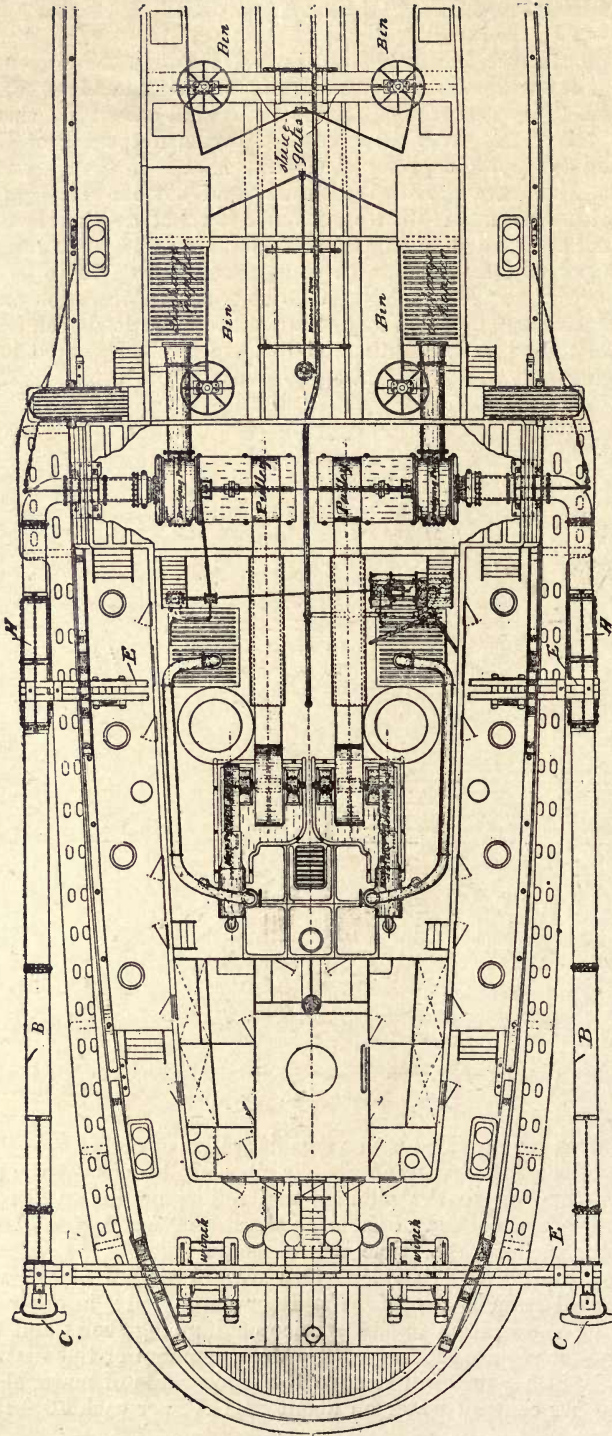

Fig. 272.—Plan Arrangement of Dredging Steamer with Two 15-inch Pumping Sets. Capacity, 12 cubic yards per minute.

lift, and a 15-inch pump 320 cubic yards on 50 H.P. per each 10 feet of total lift

A central inflow, single-suction, centrifugal pump with conical-shaped im-



Fig. 273.—Gwynne Centrifugal Pump, showing Form of Impeller.

PELLER has been designed by the Hon. C. A. Parsons for effectually dealing with fluids containing fibre and other stringy material in considerable quantity. In this pump the apex of the impeller projects into the suction bend, and fixed

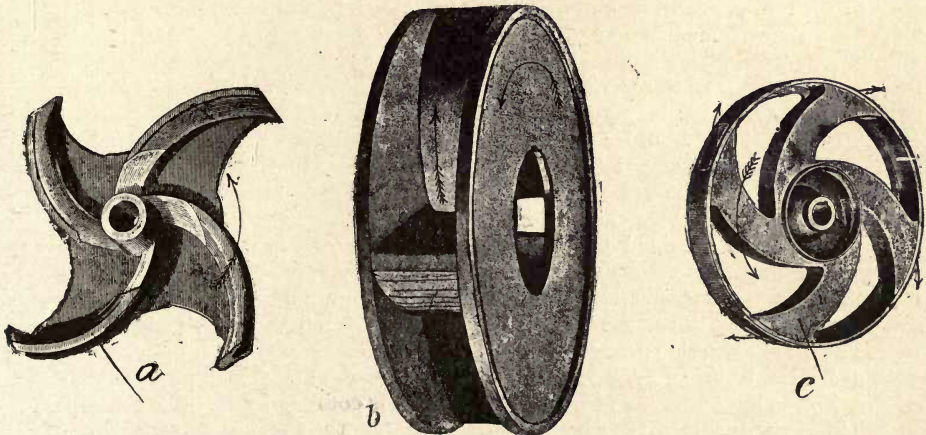

Fig. 274.—Impellers used in the Morriss Centrifugal Pumps.

to this there is a steel cutter blade held close up to the impeller vanes at a suitable angle, thus causing the impeller to act as a disintegrator on any material capable of being drawn up the suction pipe into the pump.

Besides the purposes named there are a great number of applications for which centrifugal pumps are adapted, both for low lifts ranging from 5 to 100 feet, in which the single-stage pump is most suitable, and for high lifts ranging from 100 to 1,000 feet, in which connection pumps with multiple impellers arranged in series are employed, thus extending the field of usefulness of this class of pump very considerably. In view of the importance of the modern development of the centrifugal pump, a few notes dealing with its origin and the several stages of improvements down to the present may be adduced before proceeding further with considerations involved in the construction and working of the various types of single and multi-stage pumps now in use.

Early Developments of Centrifugal Pumps and Theoretical Considerations in their Design.

As far as is known, the first application of the centrifugal principle was made by Denis Papin in 1703, drawings of a pump with the title "Hessian Suck," which are still in existence, demonstrating that this pioneer very clearly comprehended the principles involved in the working of a whirl pump. Some 50 years, however, elapsed before another investigator came forward to take up the solution of this problem—viz., Euler in 1754. The third stage was probably attained in America, where a volute pump, known as the "Massachusetts," was brought out in 1818, provided with double-suction openings and an open impeller wheel. This was again improved on by M'Carthy, in 1830, in connection with naval dockyard operations in New York. In this country the centrifugal pump was independently invented by Andrews, in 1846, its construction being shortly afterwards commenced by Mr. John Gwynne. The most important epoch, however, in the evolution of the centrifugal pump dates from 1849, when Appold exhibited a model at the meeting of the British Association at Birmingham, and later at the London Exhibition of 1851, where an improved form of Appold pump with backward curved vanes was shown which worked with an expenditure of power in notable contrast to other pumps of this class, the improvement being due to the reduction of whirl velocity in the volute.

Theoretically, half the work put into the shaft appears in the form of kinetic energy after the water leaves the impeller when provided with "radial vanes"—viz., vanes at 90° . In order to be able to recover a portion of this whirl energy, Prof. J. Thomson suggested the interposition of a race between the periphery of the impeller and the volute or whirl chamber. This construction, however, has been found to involve such an increased size and weight in the pump that any improvement obtained by this means is now no longer considered to be of compensating value. Another means for the recovery of part of this loss is to discharge the water leaving the impeller vanes into guide passages of gradually-increasing area until the velocity is sufficiently reduced to convert most of the available kinetic energy into static or pressure energy, the vertical pump designed on this principle, and illustrated by the elevation and plan sections at Fig. 275, is instructive, and was patented in this country by Nagel & Kaempe in 1874. In this pump the suction inlet is at (*s*), the vertical impeller being carried by the hollow shaft (*h*), supported by a step bearing under forced lubrication. The impeller of bronze is constructed with a number of backward curved vanes (*p*), the forward velocity whirl in the water from these being converted to pressure energy by the expanding guide passages (*e*), which deliver into a spiral vortex chamber, as shown at (*v*).

In a pump of this construction, provided that the frictional resistance along the curved impeller vanes and through the fixed guide passages can be reduced to a fine point by polishing the surface as practised in the construction of multi-stage turbo-centrifugal pumps, a considerably enhanced efficiency can be obtained, as will be demonstrated later; but for low-lift pumps all the principal

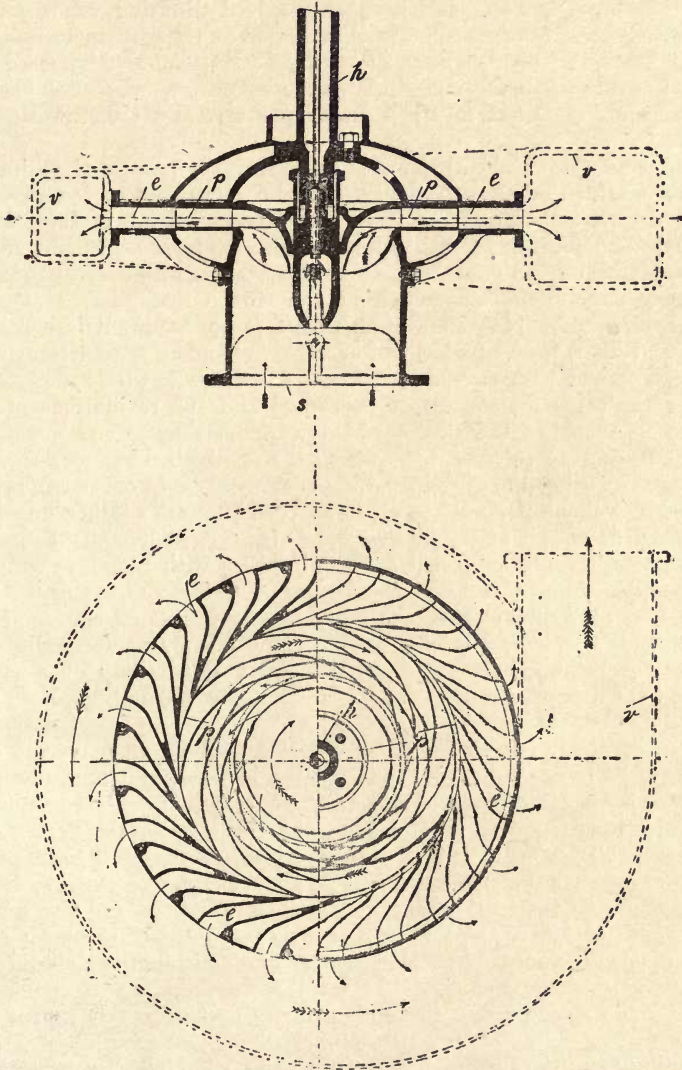

Fig. 275.—Nagel and Kaempe's Centrifugal Pump, with Ring containing Diverging Guide Passages between the Impeller and Vortex Chamber.

makers have agreed that the additional size, weight, and expense involved would afford no compensating advantage; further, in pumps of large capacity

it would not be feasible to have a polished surface of bronze alloy. As a consequence of this, in all makes of low-lift pumps the impeller discharges direct into a spiral-volute or vortex chamber proportioned very closely to the example shown at Fig. 266, with or without the cut-water plate (*t*), the function of which does not appear to have any very important bearing on the working of the pump.

A single-stage pump constructed with hinged diffusing vanes, as used in the Thomson inward-flow turbine, was exhibited at Glasgow in 1901 by Messrs. Mather & Platt, in which an impeller with backward curved vanes discharged through a series of diverging guide passages into a whirlpool chamber of ordinary form, somewhat in the manner patented by Osborne Reynolds in 1875.

In connection with diffusion losses in centrifugal pumps of various forms, some data obtained by Dr. Stanton by a very carefully-conducted series of tests in the Hydraulic Laboratory of University College, Bristol, in 1901, on models with 7-inch diameter impellers, resulted in mean efficiencies ranging from 48 to 29 per cent. with curved vanes, and 40 to 23 per cent. with radial vanes. Again, according to experiments conducted by the Hon. C. A. Parsons (*Proceedings, Civil Engineers, 1876-77*) in connection with a pump having a 14-inch diameter impeller, and usual form of whirlpool or vortex chamber, an efficiency of 44 per cent. was obtained with curved vanes and 38 per cent. with radial vanes, the speeds for the same lift of 18 feet being 206 and 163 revolutions per minute respectively. According to Mr. Howard Livens (*Proceedings, Mechanical Engineers, 1903*), from accurate tests on a pump with a 7.5-inch diameter impeller, and working against a head of 29 feet, an impeller with vanes curved backward 30° delivered 220 gallons per minute at 1,530 revolutions; another impeller with vanes curved as shown at (*b*) in Fig. 266—viz., 60° —delivered 230 gallons per minute at 1,450 revolutions, and a third impeller with radial vanes delivered 215 gallons per minute at 1,350 revolutions. Of these experiments, the first gave the best all-round results, the other two giving equal efficiencies at 140 gallons output, the second giving the highest efficiency at 190 gallons output and 1,330 revolutions; the third, with radial vanes, falling off very rapidly after attaining a critical speed of 1,320 revolutions and output of 190 gallons per minute.

Further consideration on the efficiency of the whirlpool or vortex chamber of a centrifugal pump indicates that, whereas in theory all the kinetic energy should resolve itself into potential or pressure energy if water were a non-viscous perfect fluid, it is found in practice that the efficiency of the vortex chamber never exceeds 50 per cent., and in high-speed pumps may fall to 30 per cent.; thus, in a pump with impeller vanes at 90° , a loss is incurred equal to from 30 to 50 per cent. of half the total energy imparted to the water, and in a pump with impeller vanes at 30° a proportionate loss on one-third of the total energy is incurred, and with vanes at 15° the loss in the whirlpool is reduced to from 30 to 50 per cent. of one-sixth the total energy plus an increased surface resistance, since the loss due to friction varies approximately as the cube of the speed.

Deducting from the foregoing effects: a pump with impeller vanes arranged radially (*i.e.*, at 90°) will require a larger whirlpool chamber than when an impeller with backward sloping vanes is used, the proportion of kinetic energy to pressure energy based on the assumption of a circumferential velocity being the same for the same lift as is shown by Table A.

TABLE A.—RATIO OF KINETIC ENERGY TO PRESSURE ENERGY.

Angle of Impeller Vanes in Degrees.	Ratio of Kinetic Energy.	Ratio of Pressure Energy.
90	1	1
60	1	1.23
45	1	1.44
30	1	1.9
20	1	2.6
10	1	5.2

The effect on the efficiency of an impeller due to difference of curvature of the vanes, from an angle of 90° down to an angle of 10° , is indicated in Tables B, C, and D, where θ equals the angle of the impeller vanes at the outer rim, K the hydraulic efficiency, and where $\sqrt{2gh}$ equals the peripheral velocity of impeller in feet per second.

TABLE B.—PUMPS WITHOUT DIFFUSING CHAMBERS (*Innes*).

θ	K	$\sqrt{2gh}$
90	.47	1.03
45	.58	1.06
30	.65	1.12
20	.73	1.24
10	.84	1.75

TABLE C.—PUMPS PROVIDED WITH A VOLUTE OR WHIRLPOOL CHAMBER (*Innes*).

θ	K	$\sqrt{2gh}$
90	.725	.83
45	.77	.94
30	.80	1.03
20	.84	1.19
15	.87	1.35

TABLE D.—PUMPS WITH A VOLUTE OR WHIRLPOOL CHAMBER (*Unwin*).

θ	K	$\sqrt{2gh}$
90	.6	.83
45	.8	.93
30	.85	.98
15	.9	1.2

The results indicated in the Tables A to E are entirely theoretical, no account having been allowed for the effects of viscosity and friction; they, however, are very instructive, and indicate at a glance the relation of vane angle to hydraulic efficiency and circumferential speed of impeller with and without a whirlpool or diffusing chamber; the importance of the vortex chamber in its effect on the hydraulic efficiency of the pump; and, lastly, the relation of the size of the diffusion chamber to that of the impeller, showing that the larger the ratio of size of vortex to diameter of impeller the higher the efficiency of the pump. In Table E, θ equals angle of vanes at outer rim of impeller, r the value of $\sqrt{2gh}$, and K the hydraulic efficiency.

TABLE E.—SHOWING RELATION OF SIZE OF VORTEX CHAMBER TO DIAMETER OF PROPELLER (*Innes*).

Ratio of Vortex to Impeller.				
—	1.63	1.33	1.14	1
θ	r	r	r	r
90	.78	.76	.74	.73
45	.90	.88	.87	.86
30	1.01	.98	.97	.97
15	1.33	—	—	—
K	K	K	K	K
90	.80	.86	.90	.92
45	.84	.89	.92	.94
30	.88	.90	.93	.95
15	.94	—	—	—

A test with a Gwynne "Invincible" pump, in which r equals 0.82 $\sqrt{2gh}$ and θ 17°, showed an efficiency from 47 to 62 per cent. in delivering from 1,000 to 1,700 gallons per minute against a head of from 14 to 17 feet (*Unwin*).

Another test on a 36-inch pump with impeller 5 feet 6 inches outer rim diameter, and 3 feet 3 inches inner rim diameter, indicated a velocity flow of discharge equal to from 7 to 10 feet per second against a mean head resistance of 13.8 feet at a speed of 154 revolutions per minute (*Innes*).

In the selection of a suitable form of impeller there does not appear to be much to choose between the open type shown by Fig. 273, and the enclosed-disc type shown by Fig. 267, each receiving equal favour and showing results difficult to differentiate. The wheel type shown at C (Fig. 274) with hollow curved arms is also claimed to have advantages for clear water—viz., in avoiding cavitation during the passage of the water through the impeller. This design is also claimed to permit of a more equable rate of flow from the inner rim to the outer rim. However this may be, the same effect can be produced with equal efficiency by differentiating the width of the rim at the outer and the inner diameters, so as to obtain an equal rate of flow through the impeller, which may vary from 5 to 15 feet per second, but in ordinary practice is seldom found to fall below 7 feet or exceed 12 feet per second. *The velocity of the outer rim with vanes at 90°, when not allowing for acceleration and friction, equals theoretically the velocity of a body after falling from a height equal to half the total head of the*

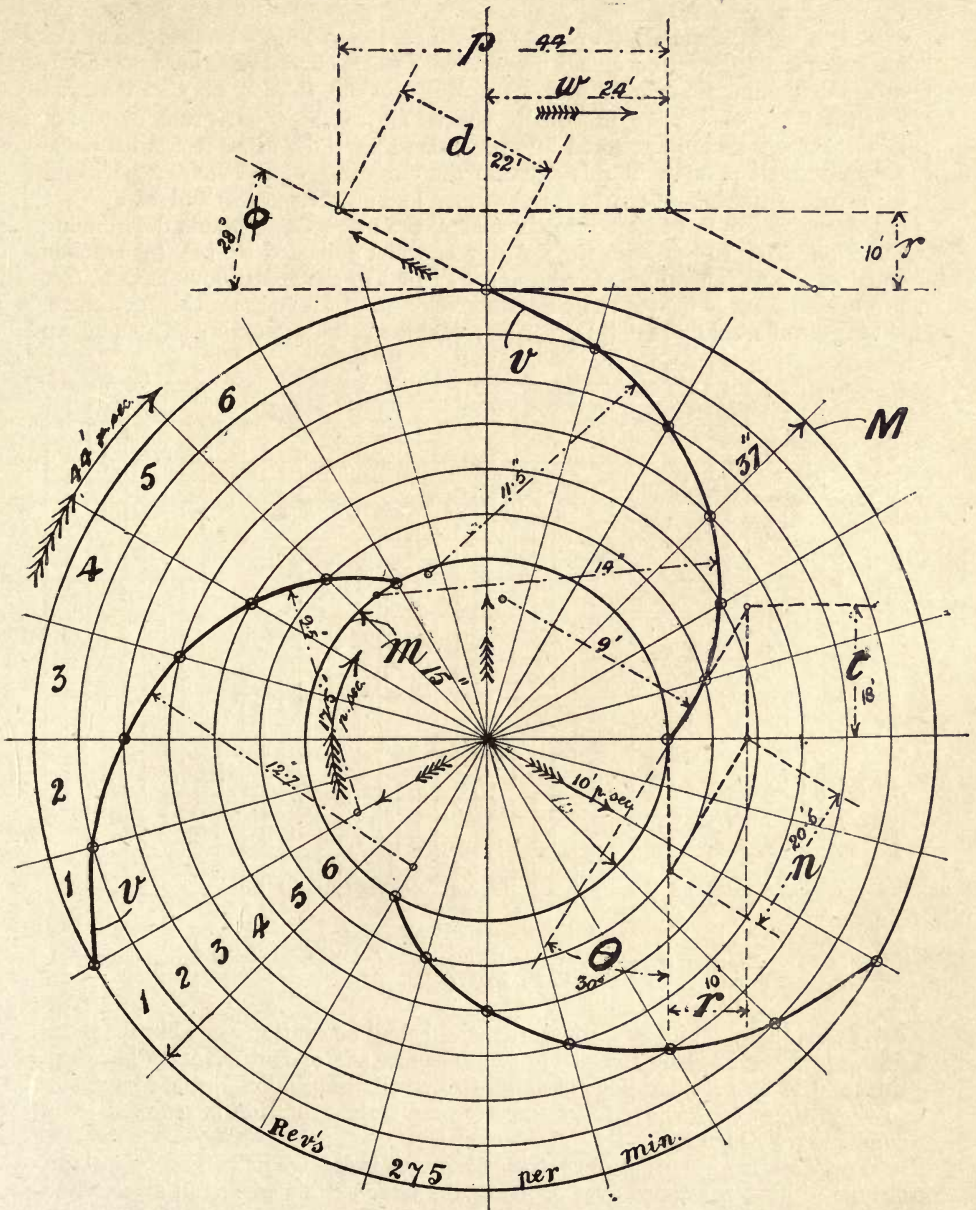

Fig. 276.—Diagram showing Development of Vane Curvature in Impeller Wheel for Pumping against a Head of 30 Feet.

water column—viz., $\sqrt{2gh}$; the tables C and D indicate the relation of velocity of rim to angle of vane; the powers of $\sqrt{2gh}$ are also stated in several of the foregoing examples. In ordinary practice with vanes curved backward, as shown in the diagrammatic development (Fig. 276), the rim velocity may be taken as $8\sqrt{\text{total lift}}$, this being practically equivalent to the square root of $g \times h$, this velocity working out to 44 feet per second for a lift of 30 feet, with angle $\phi = 28^\circ$ and $\theta = 30^\circ$. In this diagram the curvature of the vanes V is found by dividing the interval between the inner and outer rims (m) and M into six spaces, as also each quarter into six spaces, the intersecting points determining the curvature; to ascertain the velocity of whirl indicated by (w), (p) is made equal to the peripheral velocity M, and (r) equal to the radial flow, both in feet per second; (d) indicates the backward velocity of discharge; this, of course, if tangential would equal (p); (n) and (d) should be approximately equal, in

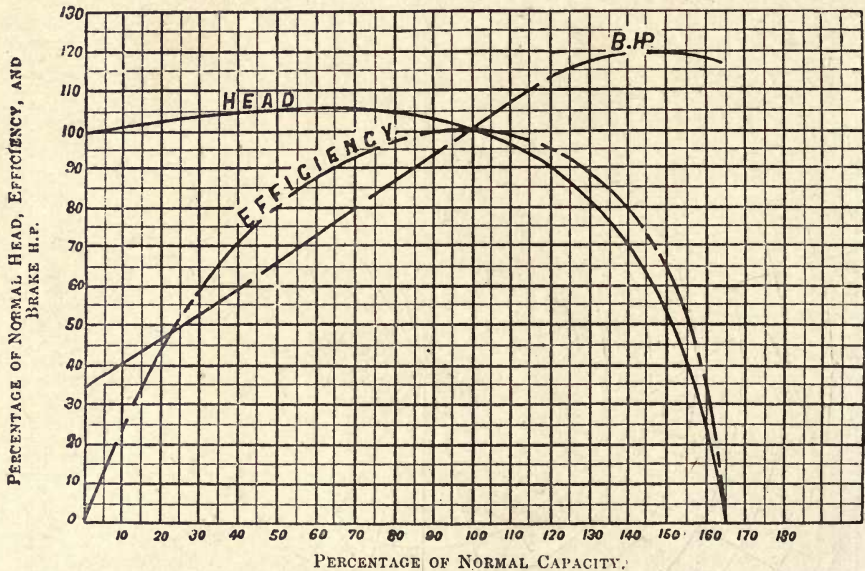

Fig. 277.—Diagram showing Variable Delivery of Low-lift Centrifugal Pump under throttled Discharge Control.

order that the rate of flow through the wheel shall be continuous. The diameter of (m) is determined by the size of suction pipe, and should never be less than this, and M by considerations of speed to lift, the proportion varying from two to three times (m), or even five times, where a slow rotation is required for a comparatively high lift.

The variation in output of centrifugal pumps is greatly influenced by a slight change of head resistance over or below the designed lift when run at constant speed. For this reason, impellers with radial vanes are only used for a constant lift, under which conditions even an angle of 60° , as shown at b (Fig. 266), is preferred by most makers, this particular pump being designed for a constant lift of 27 to 28 feet, its efficiency then attaining a maximum of 75 per cent., with an output of 150 tons per minute. For purposes wherewith the lift is

subject to great fluctuation, as in emptying docks, a more acute angle is used, the more nearly tangential the discharge the wider the range of lift; the dia-

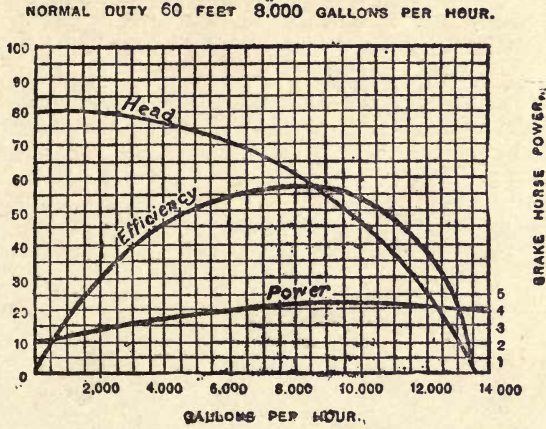

Fig. 278.—Diagram of Rees-Roturbo Self-regulating Pump.

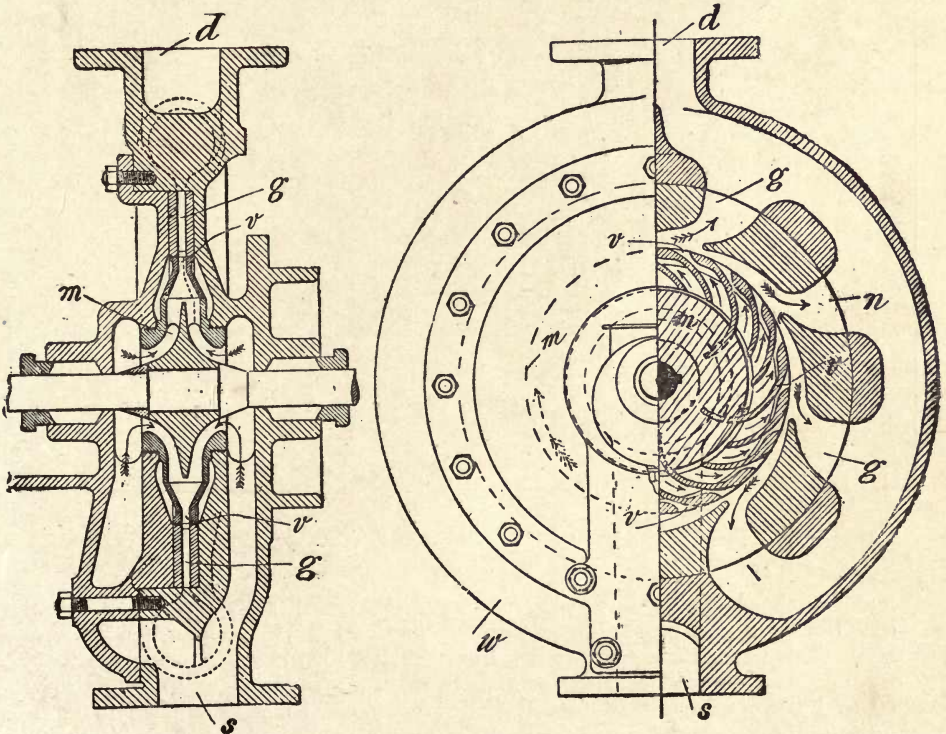

Fig. 279.—Sectional Elevations of the Rees-Roturbo Self-regulating Centrifugal Pump.

grams (Fig. 265) taken from a pump with impeller, as shown at *a* (Fig. 266)

emphasise this statement, this pump being designed to work between the limits of lift ranging from 22 to 34 feet at constant speed, between which limits, although the output increases from 1,300 to 1,800 gallons per minute, the water horsepower remains practically constant.

The method adopted in Worthington single-stage low-lift pumps—viz., to throttle the discharge by the use of a delivery-gate valve—permits a constant degree of head resistance over a wide range of lift at constant speed; for instance, on referring to the diagrams (Fig. 277) it will be seen that by this means a practically constant head can be maintained between zero and normal capacity, the

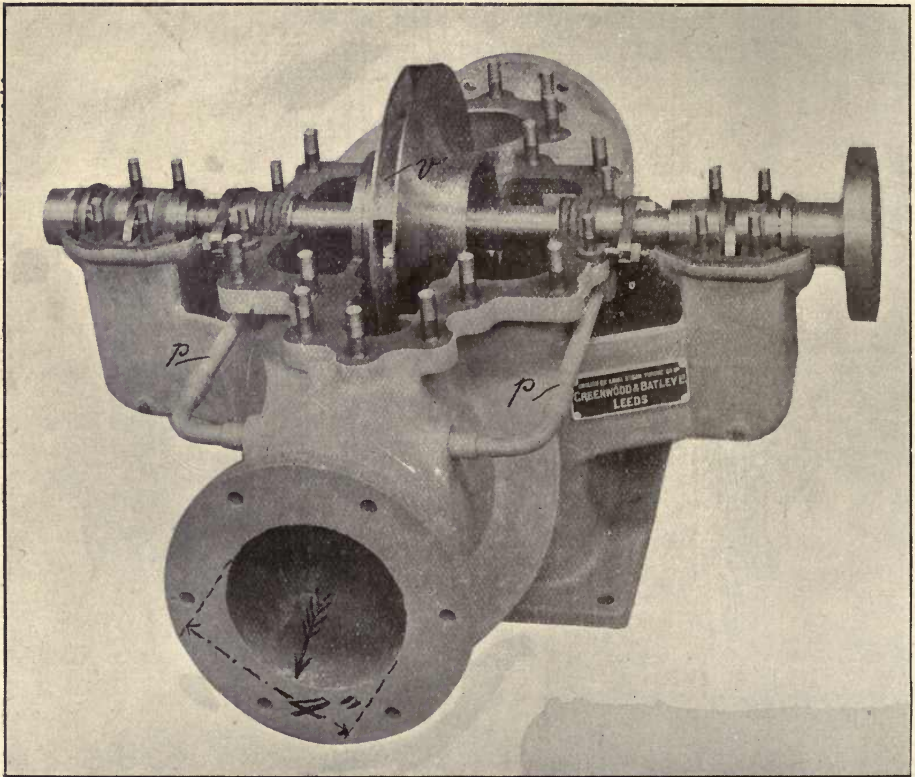

Fig. 280.—De Laval High-speed Centrifugal Pump, showing Form and Arrangement of Impeller.

increased head due to throttling from normal to 50 per cent. capacity being only 8 per cent., although in this, as needs be in all cases, the highest efficiency is obtained under fixed conditions; from the diagrams it will also be seen that the efficiency only drops 5 per cent. between a range of capacity output from 80 to 120 per cent. This method of delivery control can be applied to both horizontal and vertical types of low-lift pumps.

Pumps designed to work on the self-regulating power principle—viz., to discharge as nearly as possible tangentially—are shown by Figs. 279, 280, and 281; the diagram (Fig. 278) illustrates this effect in a "Rees-Roturbo" pump,

in which the power is seen to fluctuate but little over an extremely wide range of delivery, this result being due in part to the venturi-shaped vane orifices at (*v*), and to the frictional resistance caused thereby increasing in a higher ratio than the velocity of discharge, thus tending to automatically throttle the discharge to a greater extent on a reduced lift than in normal working. Referring to the sectional drawings (*s*) and (*d*) are the suction and delivery branches, (*m*) the impeller with conoidal deflector disc and series of throat-shaped vane passages (*v*), any whirl velocity from these being converted to pressure energy by the guide passages (*g*). The junction of the rotor (*m*) and stator (*n*) is grooved to form a seal.

Centrifugal pumps of the self-regulating order are particularly adapted in combination with gas, oil, petrol, and electric motors for such purposes wherewith a considerable difference of suction lift is inseparable—viz., due to tidal and other causes—and have the distinguishing advantage in this connection over all other types of pumps of working at constant torque over a wide range of pressure head.

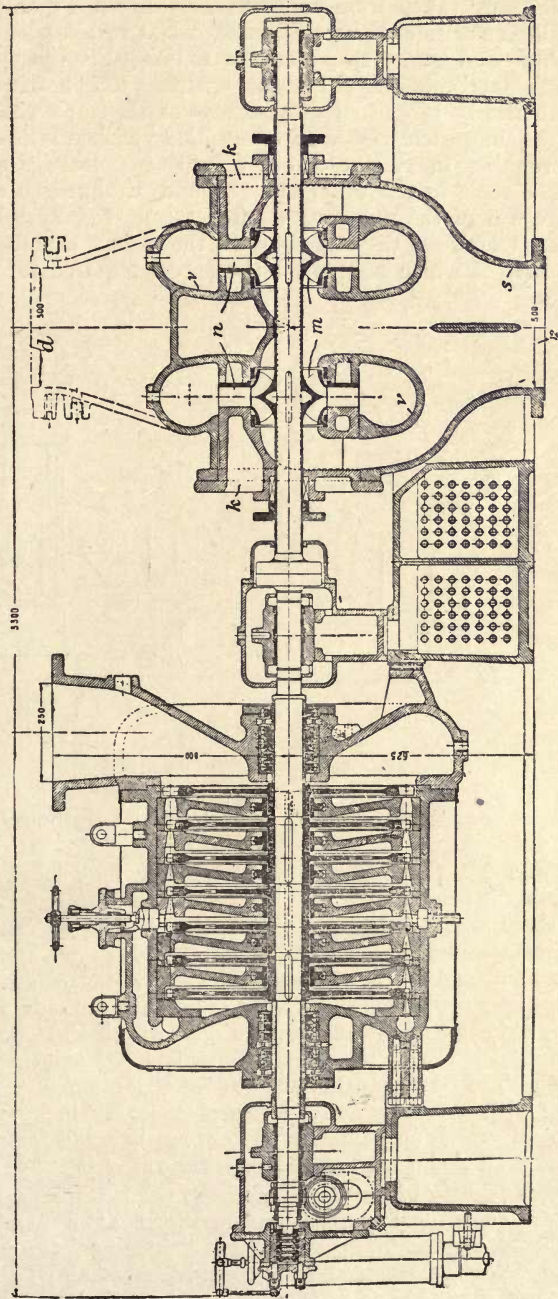

Fig. 281.—Twin Wheel Single-stage Turbine Pump. Capacity, 1,800 Gallons per minute, raised 120 feet; speed, 3,300 revolutions per minute.

The De Laval high-speed single-stage centrifugal pump (Fig. 280) illustrates another type, the distinguishing feature of which is its remarkably high speed, the cut being taken from an electrically-driven 4-inch pump designed to lift 160 gallons per minute at a speed of 2,200 revolutions, the largest size—viz., 30 inches—and having a capacity of 15,000 gallons per minute, being designed to run at 600 revolutions per minute against a total head of 30 feet. The impeller (*v*) with nearly tangential discharge is of the type used in multi-stage high-pressure pumps, and is cast in bronze and polished inside and out, the impeller shaft running in ring-oiled outer bearings; leakage of air is prevented by hydraulic seals in the usual manner, and arranged to communicate with the pressure end of the pump by the pipes (*p*). No diverging guide passages are interposed between the impeller and the vortex chamber, the removal of the upper half of which affords all the access required for full inspection of the impeller.

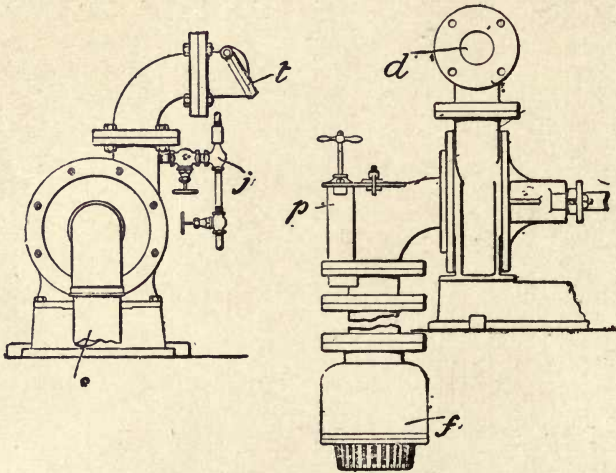

Fig. 282.—Starting Arrangements for Centrifugal Pumps.

In Fig. 281 there is illustrated another high-speed single-stage pump of remarkable capacity, and, like the preceding example, is specially adapted for being steam-turbine driven; this pump, known as the "Stork" turbine, is fitted with twin impeller wheels (*m*), which each draw at both ends from a 12-inch suction inlet, and deliver through diffusion vanes (*n*) into volute chambers (*v*). The impellers are 7 inches diameter only, thus are only a little more than one-half the diameter of the suction and delivery pipes. The rated capacity of the turbine at 3,300 revolutions per minute is 1,800 gallons per minute raised 120 feet high. The Zoelly steam motor turbine is rated at 120 H.P., and although working with a 7-stage action, runs at the very high speed of 55 revolutions per second, which accounts for the extremely small impeller wheels; even so, the backward inclination of the impeller vanes must be at least 25° , and the peripheral velocity of the impeller wheels not less than $1.15 \sqrt{2gh}$.

When centrifugal pumps are arranged at a level above the suction supply, means must be provided for "priming" the pump before starting; this can either be attained by a foot valve, as at (*j*) Fig. 282, or by a valve on the discharge pipe as at (*t*), which may either be a non-return or a stop

valve; the pump may then be "primed" by exhaustion in the one case and by filling in the other. The usual method adopted with steam-driven pumps is the combination of steam ejector and valve as at (j) and (t), no foot valve to (s) being required in this case; with a foot valve as at (f), the pump and suction pipe may be conveniently filled by a hand-pump as at (p), or from a pressure supply. Gas, oil, or electrically-driven pumps may be "primed"

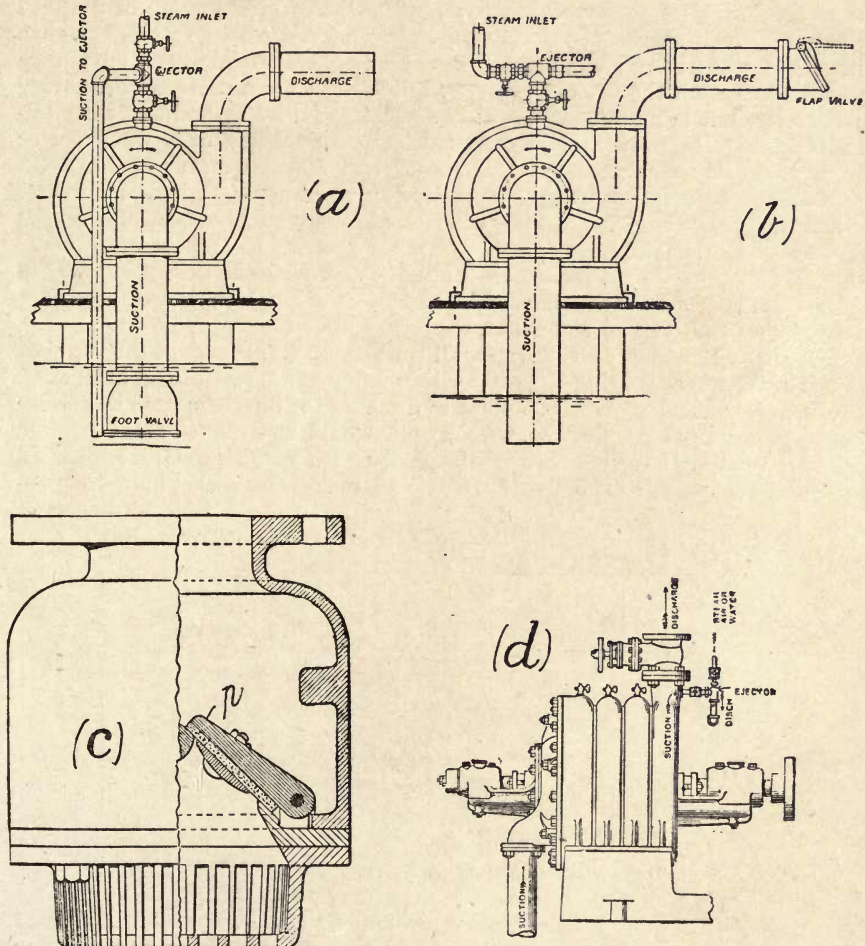

Fig. 283.—Starting Arrangements for Single and Multi-stage Centrifugal Pumps.

either by an auxiliary water or air pump; or by a compressed-air or water jet ejector, as shown at (d), Fig. 283, applied to a four-stage pump, in combination with a stop-valve on the discharge; or, again, when fitted with a foot-valve the pump may be primed by simply filling with water. A practical form of foot-valve is shown at (c), in which a pair of leather-faced flaps (p) are held over the stops at the side of the casing when pumping, and thus oppose no obstruction to the inflow.

High-Lift Multi-Stage Turbine Pumps.

The distinguishing feature of all high-pressure centrifugal pumps is the use in multi-stage form of a series of impellers, each discharging into a chamber provided with guide passages, or diffusion vanes, for the purpose of converting as much as possible of the available kinetic or momentum energy imparted to the water during its passage through the several stages, into static or pressure energy, and by this means to render a higher general efficiency than possible with the use of vortex chambers. Theoretically there would be no advantage to be derived from the use of guide vanes if water were a perfect fluid having no viscosity, but in practice it has been demonstrated by several experimentalists, including Dr. Stanton and others, that the efficiency of a whirlpool or vortex chamber never exceeds 50 per cent., and may fall below 30 per cent. From actual experiments with a pump having an impeller 11 inches diameter for instance, it has been found that, whereas a theoretical increment of potential or pressure head in the vortex chamber from the rim of the impeller to the point of discharge should have been as high as 52 feet, the actual increase of pressure did not exceed the equivalent of 20.5 feet of head, thus in this instance indicating an efficiency of conversion of kinetic to static energy of 39 per cent. of approximately 34 per cent. of the total energy, the inclination of the vanes at the rim of the impeller being 30° ; in another pump, with vanes at an inclination of 45° —a very usual angle at the point of discharge of impellers used in turbine pumps—a corresponding loss on 43 per cent. would be incurred; the relation of kinetic to static energy differences in pumps with varying velocities of whirl in the vortex chamber, as compiled in Table F., makes this action quite clear:—

TABLE F.—COMPARISON OF STATIC AND KINETIC TO TOTAL ENERGY.

Angle of Vanes at Rim of Impeller.	Kinetic Energy.	Static Energy.	Total Energy.
90	242	242	484
60	194	239	433
45	162	234	396
30	122	218	330
20	61	161	220
15	25	131	156

Further experiments with other pumps have demonstrated the advantage of using diverging or guide vanes to be from 53 to 49 per cent., as compared with 48 to 29 per cent. with curved vanes and 40 to 23 per cent. with radial vanes respectively when run without guide vanes. From Table F it will also be noted that the greatest advantage to be derived from utilising the turbine principle is with impeller vanes at an inclination of about 45° , when a wide range of pressure head or speed is not required, and further that the more closely the discharge from the impellers approaches a tangent, the less the duty of the pump and also the less the advantage to be gained by the use of guide vanes between the several impellers; nevertheless, series centrifugal or turbine pumps can be and are made to work with a fair efficiency over a considerable range of pressure head, but it must on no account be understood that by any inclination of vane disposition in either the impeller or guide passages, can as high a degree of

efficiency be obtained as under fixed conditions of pressure head and speed, notwithstanding the claims to the contrary that may be put forward for any particular modification of this extremely useful and adaptable class of pump.

The first application of the high-pressure centrifugal pump on the multi-stage principle was patented by John Gwynne in 1851, who shows a 4-stage pump in his specification 13 577; following this may next be mentioned Girard's pump, as illustrated in patent No. 30, 1855. Yet it was not until the introduction and more general use of electric and steam turbine power, however, that centrifugal pressure or series pumps for high lifts came into active competition with plunger pumps, in the construction of which, as will be seen by the several representative examples of the most notable makes, there is a close family likeness, the principal differentiation consisting in the method adopted for balancing end thrust, of coupling together the several elements, and in the disposition of the diffusion passages.

In the sectional views (Fig. 284), which clearly show the construction adopted in the modern "Gwynne Invincible" multi-stage pump, each impeller H is provided with a conoidal disc E, which serves to deflect the flow, entering at both sides of the impeller at G, from passages I into a radial direction, the angular discharge from the impeller vanes being diverted by guide vanes in rings M into pressure energy, and to enter chambers F and communicating passages I in succession, thereby advancing the water pressure flow forwards in stages until it is finally discharged through K to the outlet L. In point of construction for a 3-stage pump, the two sections B are secured by bolts N between the suction and delivery parts A, each section being formed complete with water-ways F and I, an intermediate bearing and recess for carrying a deflector or guide ring M; a 4-stage pump is provided with three sections, a 6-stage with five, and so on, according to the pressure required

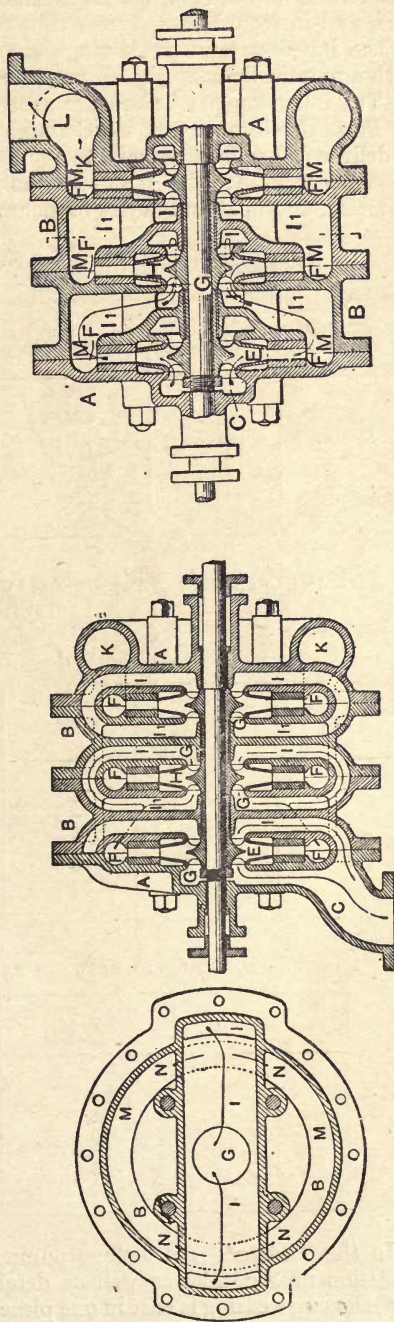

Fig. 284.—Sectional Elevations of Three-stage High-lift "Invincible" Centrifugal Pump.

or speed available. As each impeller is separately balanced by the double inlet G, there is no need for special means to compensate for end thrust other than this, and in regard to delivery, wherever required, the inclination of the vanes in the impellers and guide rings can be proportioned for the pump to work with a practically constant torque over a wide range of pressure head.

The following particulars are abstracted from a report of a test conducted by Prof. Unwin on a modern Gwynne 4-stage "Invincible" pump, constructed to deliver 660 gallons per minute against a total head of 180 feet, at 1,200 revolutions per minute; this pump having four balanced action impellers 12 inches diameter, and inlet and outlet branches 8 inches diameter.

GENERAL EFFICIENCY OF "INVINCIBLE" 4-STAGE PUMP.

Revolutions per Minute.	Total Head in Feet.	Brake Horse-power.	Hydraulic Horse-power.	Efficiency per Cent.	Gallons per Minute.
1,135	84	42.0	21.7	50.4	840
1,140	100	42.0	24.6	55.2	800
—	140	42.2	27.0	64.2	630
—	150	42.0	27.3	65.0	600
1,240	185	44.0	31.0	70.5	560

SIMULTANEOUS PRESSURE GAUGE OBSERVATIONS IN A 4-STAGE "INVINCIBLE" PUMP.

CASING PRESSURES IN LBS. PER SQUARE INCH AT EACH STAGE.

Suction Pipe Vacuum.	Head in Feet.	1st Stage.	2nd Stage.	3rd Stage.	4th Stage.	Delivery Pipe.
2.2	83	7.3	15	24	36	32
2.2	84	7.8	16	25	36	32
2.2	97.6	8.8	19	30	42	38
2.1	102.2	9.3	19	30	44	40
2.0	185.3	20.5	38	60	80	76

PRESSURE DIFFERENCES BETWEEN EACH STAGE IN LBS. PER SQUARE INCH.

0-1	1-2	2-3	3-4
9.5	7.7	9.0	12.0
10.0	8.2	9.0	11.0
10.9	10.2	11.0	12.0
11.5	9.7	11.0	14.0
22.5	17.5	22.0	20.0

In the "Sulzer" multi-stage pump, of which two modifications are shown in section at Fig. 285, as well as detailed particulars of the balancing device used, the outer casing is cast in one piece with pockets (*v*), which serve to connect

up the guide passages (*s*) in the stator rings (*g*), with water ways (*w*) communicating with the inner rims of the impellers (*r*); these, although arranged in

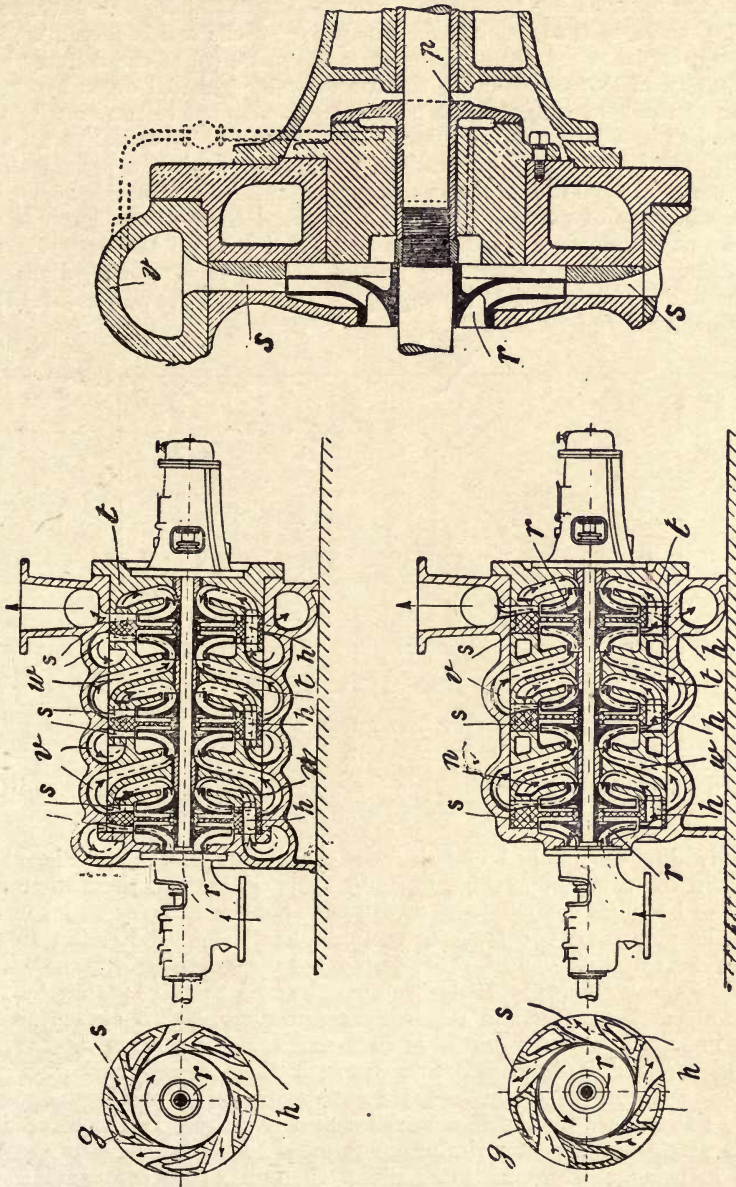

Fig. 285.—Sectional Elevations of Six-stage Sulzer High-lift Centrifugal Pump.

pairs on each side of the stator rings (*g*), are separated by bearings forming part of each ring, water from the impellers on the suction side passing through

ways (*h*) in each ring to passages (*n*) communicating with the inner rims of the impellers arranged on the delivery side of the stator rings. Each ring (*g*) is provided with two sets of guide passages (*s*), the several rings being held in position in the outer casing by intermediate sections containing the water ways (*w*) and (*n*), these in turn being locked in place by the end section (*t*). Unbalanced end thrust is compensated for by a disc valve (*p*) at the delivery end, another feature in this pump being the use of water-jacketed outer bearings; by the use of the balancing disc the pump can be adapted to run equally well in a vertical as in a horizontal position. The working of a vertical pump at a constant speed of about 1,025 revolutions per minute, against a pressure head varying from 130 to 150 feet, is shown by the diagrams (Fig. 286), in which curve 2 denotes efficiency of pump, curve 3 the electrical horse-power, curve 4 the brake horse-power, curve 5 the pressure head, and curve 6 the output. The line 1 cutting the several curves at normal output—viz., 3,500 gallons per minute, head 150 feet, electrical horse-power 210, water horse-power 159—thus showing an efficiency of 75 per cent.

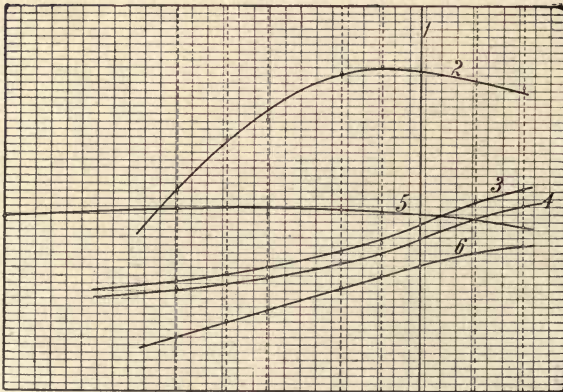

Fig. 286.—Diagrams showing Output, Power, and Efficiency of Sulzer Electrically-driven Sinking Pump.

A totally different method of balancing end thrust on the impeller shaft is adopted in the two pumps (Figs. 287 and 288); in both of these there is a double set of impellers communicating with one common delivery outlet in the centre of the pump and two separate suction inlets at opposite ends. In the Hayward-Tyler or Gelpke-Kugel, rotor discs 2 are carried back to back against stator discs 5, both being provided with curved vanes as at 12; thus by this system of alternating rotor and stator discs armed each with curved vanes, the whirl imparted to the water is in part maintained until arriving at the centre disc, where it is discharged into a vortex chamber provided with cut-water vanes as shown. In a pump of this construction, part of the kinetic energy imparted to the water by the first impeller disc is utilised in the succeeding stages, the path from the outer rim of one impeller to the inner rim of the one preceding it being shorter and more direct than in either construction yet considered.

As in all series turbine high-lift centrifugal pumps, all surface over which the water flows is polished, and the direction of flow designed to be as free as possible from abrupt changes, and in this particular pump the further advantage

is obtained of preserving a comparatively continuous and even velocity right through from the race of the first impeller to the point of discharge into the delivery vortex.

A very similar effect is obtained in the Davey 4-stage pump illustrated by Fig. 288. Here the suction flow is also divided, and enters by the two inlets E to the two impellers A, these discharging into the whirlpool chambers H, where the flow is directed by fixed vanes D to the conoidal-shaped formation leading to the inner rims of the two intermediate impellers A¹ and hence by successive stages to the central double impeller A³ and vortex J to the outlet K. In this pump, as in the preceding example, the whirl velocity at the point of discharge from the outer rims of the impellers is deflected by the fixed vanes D, D¹, D², so as to cut the vanes at the inner rims of the impellers at a velocity as nearly equal to these as possible.

In the Worthington high-lift pump illustrated in section by Fig. 289, direct communication from the outer rim of one impeller to the inner rim of the one preceding it is obtained in a similar manner, the circular diffusion chamber in this case being continued in a radial direction, so that some part of the whirl velocity can be converted to pressure energy before the water is deflected to take a centripetal direction in order to enter on succeeding stages. As in the two preceding examples, the velocity of flow is maintained as far as possible uniform, and to enter each succeeding impeller with an angular velocity coincident with that of the inner rim. In the construction under consideration there is a minimum of resistance to the water flow through the pump, there being no obstruction other than that afforded by the series of thin smooth surface diverging vanes. Each impeller is independently balanced by a piston extension and the pump body built up in a series of sections according to the pressure required. The diagrams (Fig. 290) indicate the characteristic action of a multi-stage pump of this make from zero up to 80 per cent. above normal,

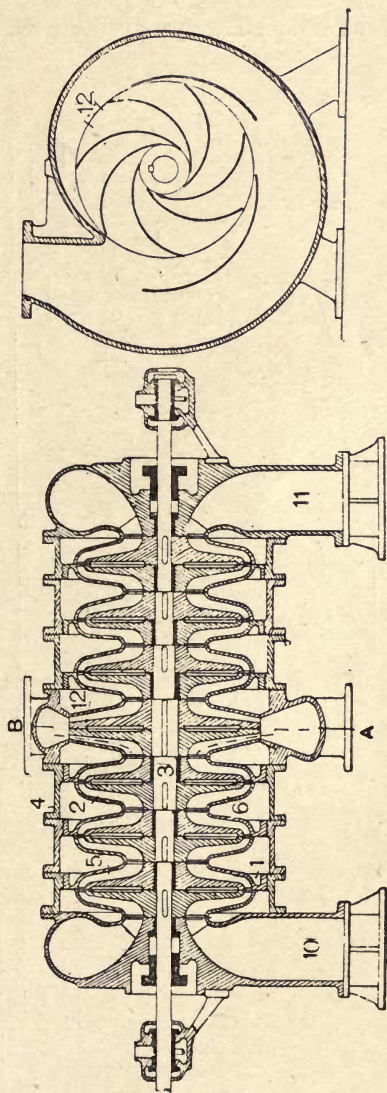

Fig. 287.—Sectional Elevations of Hayward-Tyler Four-stage High-lift Centrifugal Pump.

turbine pumps with diffusion vanes being supplied in single-stage and up to 6-stage, and for exceptionally high lifts can be arranged in coupled series units, which has its advantages under certain conditions of volume and pressure head. In the Mather & Platt high-lift turbine action series centrifugal pump, illustrated in section at Fig. 291, there are outward flow as well as inward flow diffusion vanes at K and H respectively in the stator sections A, the outward curved

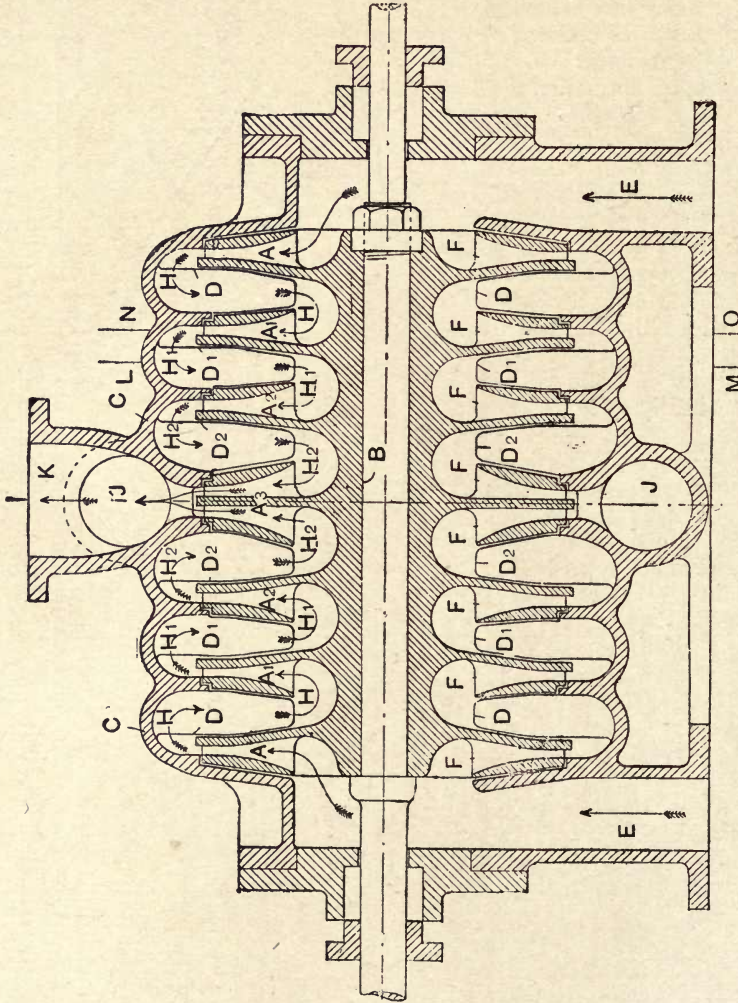

Fig. 288.—Longitudinal Section of Davey's Four-stage High-lift Centrifugal Pump.

diffusion passages formed by the vanes K communicating through passages C with water ways confined within the inward curved vanes H. Thus it will be seen that the circuit from the inner rim of one impeller to that of the next preceding it follows a path of easy curves; the water flow at the inner rims S from the inward curved diffusion passages at H is continued to the conoidal formed impellers N with a minimum interference in velocity and change in

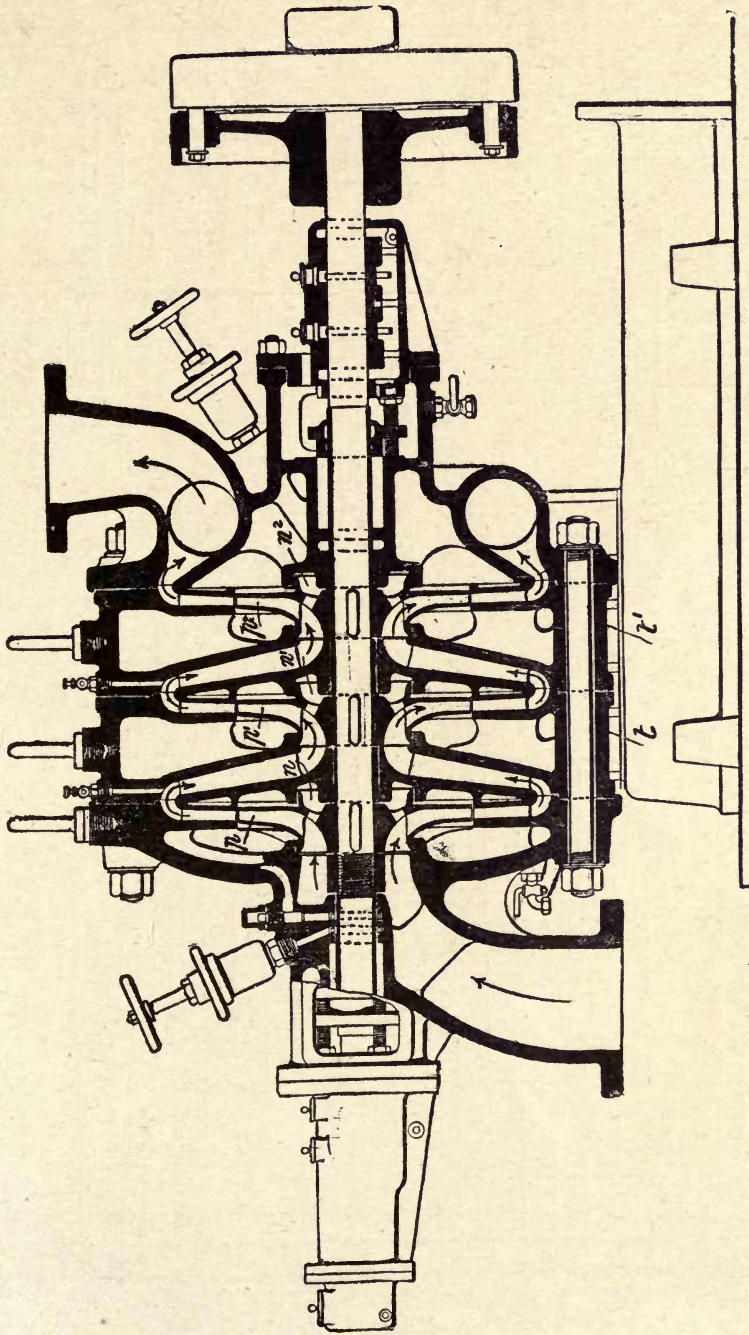

Fig. 289.—Sectional Elevation of Worthington Three-stage Turbine Pump.

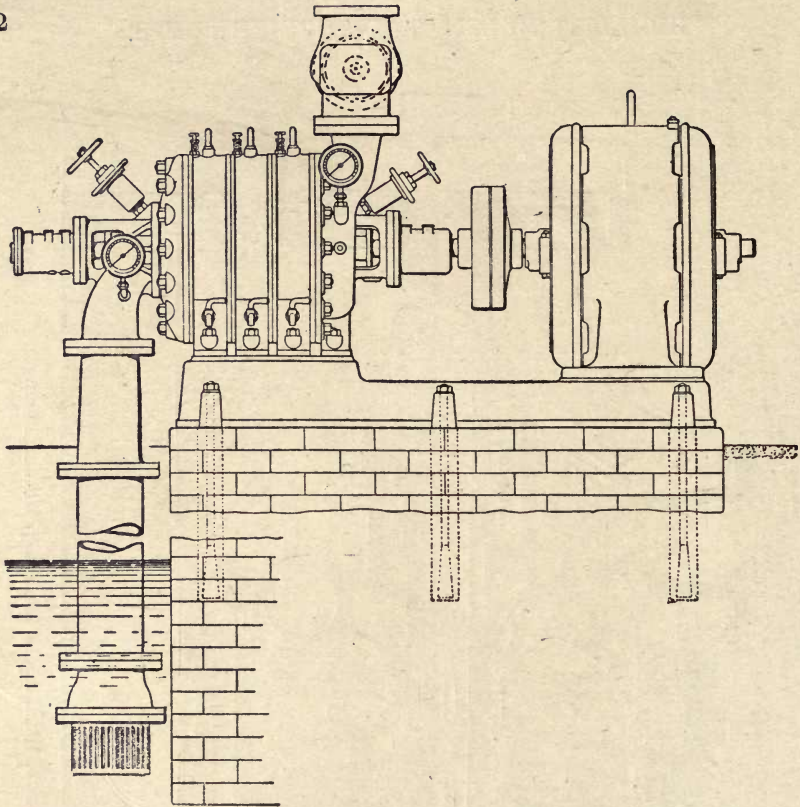

Fig. 289a.—General Arrangement of Connections for Worthington 3-Stage Pump.

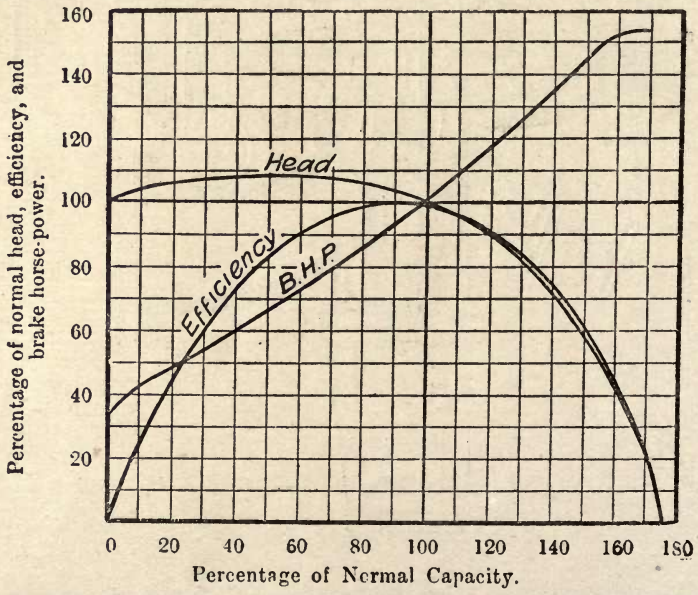

Fig. 290.—Characteristic Curves of High-lift Worthington Turbine Pumps.

direction. In this pump intermediate bearings are entirely dispensed with, the space thus available for the long radius annular passages L more than compensating for any lack of rigidity to the shaft M. Difference of end balance is corrected by a piston R and adjustable communication W with the delivery end of the pump, a slight endways movement of the shaft not materially affecting

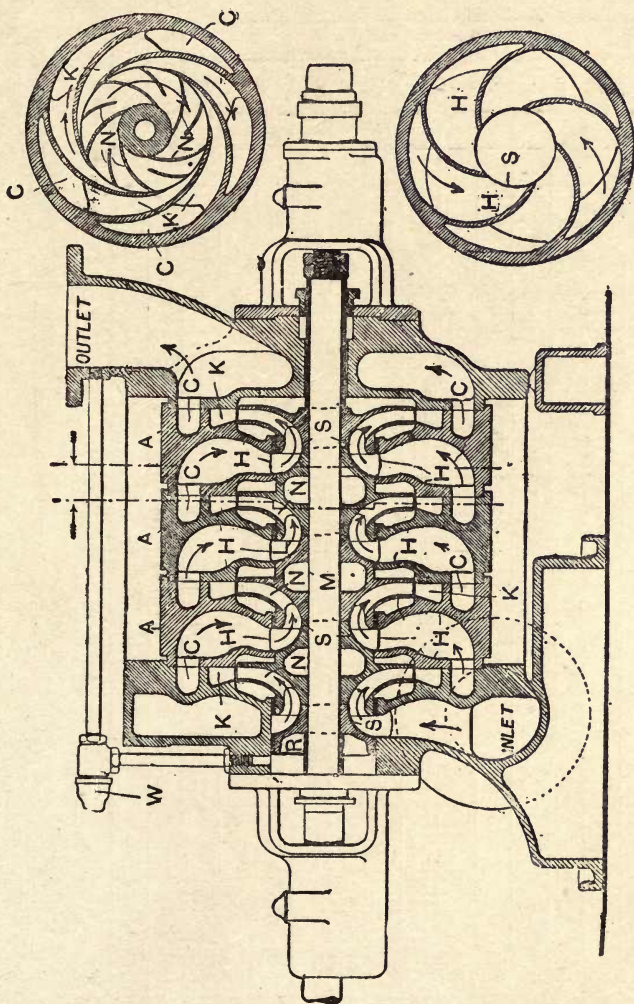

Fig. 291.—Sectional Elevations of Mather & Platt Four-stage High-lift Centrifugal Pump.

the efficiency of its working, thus reducing slip that may occur in some cases, either as a result of wear or incorrect alignment.

The three series of diagrams (Fig. 292) explain the action of this pump very clearly, the full-line curves indicating a constant pressure head from zero to within 10 per cent. of full delivery—viz., 1,300 gallons per minute at constant speed—and the efficiency remaining within the limits of 68 and 72 per cent. for an output of 900 to 1,500 gallons per minute. The effect of change of speed

is indicated by the two dotted line curves, these showing the relation of speed to pressure head and efficiency at constant output of 1,300 gallons per minute, the efficiency remaining within 66 and 72 per cent. between the limits of speed corresponding to 600 and 850 revolutions per minute, and the pressure head varying almost in a direct line from 40 to 150 feet. The chain line curves show the relation of speed and efficiency at outputs ranging from zero to 2,200 gallons

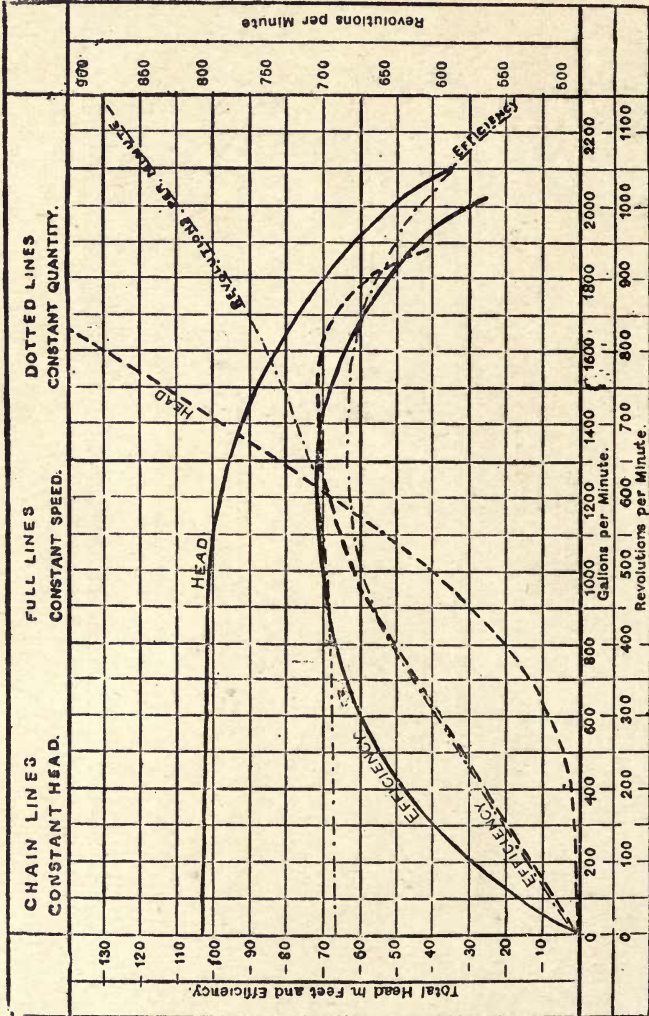

Fig. 292.—Diagrams of Mather & Platt's High-lift Centrifugal Pumps.

Full Line Curves.—Showing head and efficiency at various outputs and at constant speed of 700 revolutions.
 Dotted Line Curves.—Showing head and efficiency at various speeds and at constant output of 1,360 gallons per minute.
 Chain Line Curves.—Showing revolutions and efficiency at various outputs when delivering against constant head of 100 feet.

per minute, the efficiency remaining within 57 and 64 per cent. between the limits of output, ranging from 900 to 1,800 gallons per minute, and at corresponding speeds of from 660 to 780 revolutions per minute. Assuming an output of 1,200 gallons to be normal, it will be seen that the efficiency only varies 4 per cent. with a total variation in output of 50 per cent. ; again, at constant output the increase in speed is practically 5 revolutions for an increment of

1 foot in pressure head; and, thirdly, the volume delivered at constant head is doubled with an increase in speed of about 17 per cent.; results which, as in the case of the foregoing, substantiate the necessity for running a pump of this class under fixed conditions in order to obtain the best effect.

In emphasis of the wide range of pressure and volume capacity to which the turbine action centrifugal pump has attained, may be instanced an installation of four electric pumping sets of this make recently supplied to the Montreal Waterworks, each comprising a 3-phase motor of 1,600 B.H.P. and pump of 10,500 gallons per minute capacity against a head of 405 feet at a speed of 465 revolutions, this representing a water horse-power of 1,290 and efficiency equal to 80 per cent.

A noticeable feature in the "Escher Wyss" high-lift multi-stage pump is the double curvature of the impeller discs, these being formed as shown in the sectional views (Fig. 293), so that the water enters and leaves the runner in an axial direction, a method resembling in some degree the forward delivery single-disc impellers used in the Gelpke-Kugel pump shown at Fig. 287; the impeller used in the 6-stage pump now being considered are of the double disc type with vanes as at (b), and discharge at an angle of about 60° direct into the double disc diffusion chambers with fixed vanes (c) at an angle so as to receive and deliver into the preceding impeller at a

velocity of whirl corresponding to that of the inner rim at (a). From a theoretical point of view, the directness of the route from the periphery of one impeller to the axis of the next—thus avoiding all unnecessary curvature and sharp bends, together with the means adopted for reversing the direction of flow—should reduce frictional and eddy losses to a minimum. In this

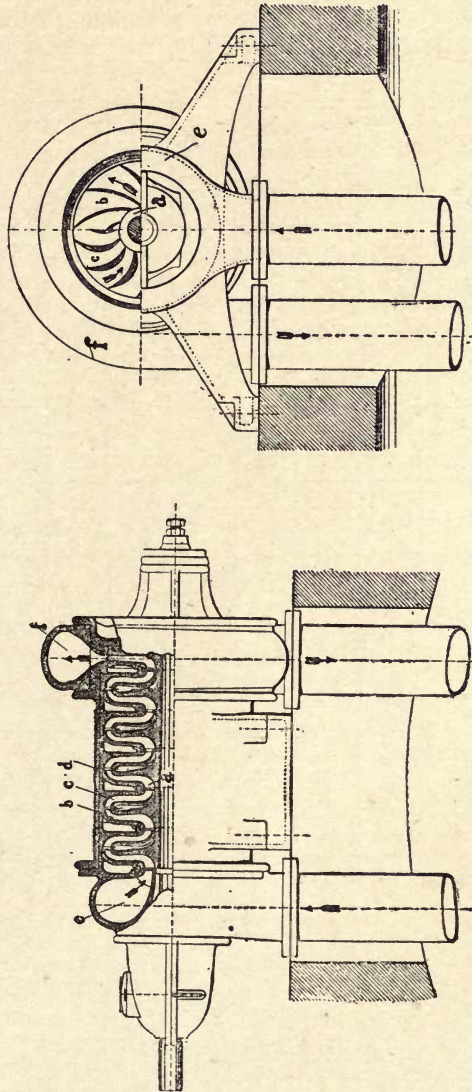

Fig. 293. —Sectional Elevations of Escher-Wyss Six-stage High-lift Centrifugal Pump.

pump, as in the Mather & Platt (Fig. 291), there are no intermediate bearings, the space in both being utilised in the easier curvature of the guide passages. Slip between the rotor and stator elements is prevented by spigot or labyrinth joints, without any contact of the rotating with the stationary parts being necessary, accurate adjustment endways being ensured by a ball-thrust bearing.

The diagrams (Fig. 294) serve to indicate the influence of variation in volume of output on the efficiency of a 4-stage pump with impellers 12 inches diameter

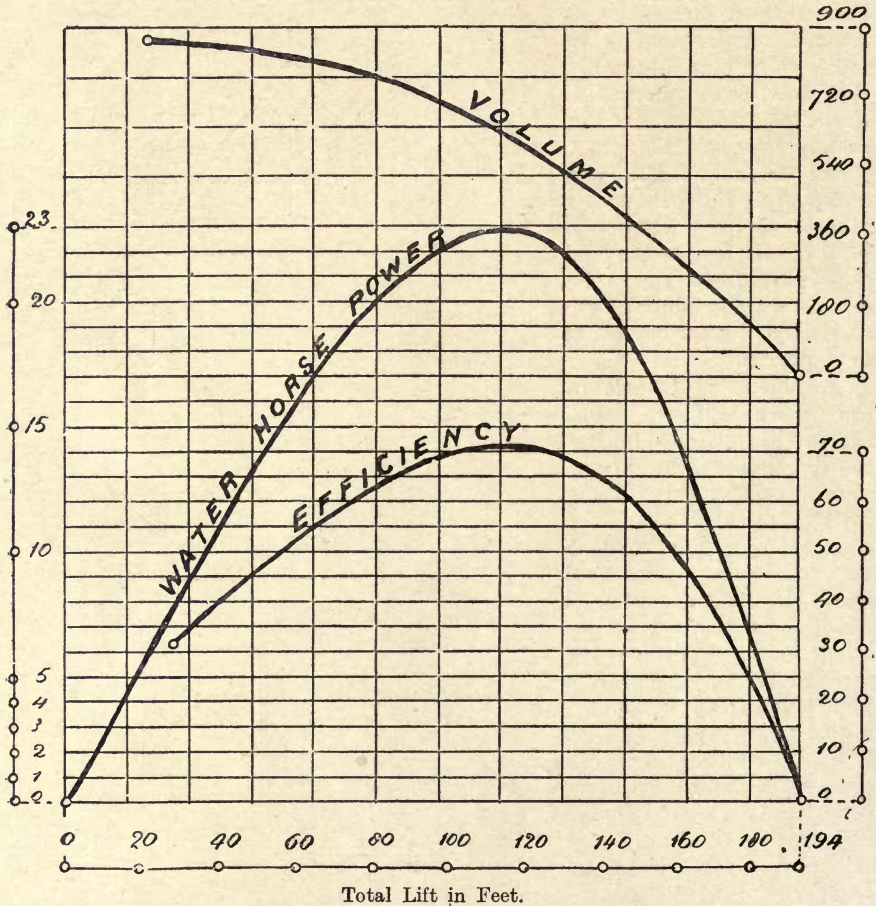

Fig. 294.—Diagram showing Working of Escher-Wyss Four-stage High-lift Centrifugal Pump.

running at a speed of 950 revolutions per minute, and requiring a maximum of 33 B.H.P. when pumping a volume equal to 630 gallons per minute against a pressure head of 120 feet; this pump, when run at the same speed, increases the volume of its output to 850 gallons per minute, against a reduced pressure head of 20 feet, while the delivery ceases altogether at a maximum pressure head equal to 194 feet; the efficiency remaining within 68 and 72 per cent. when delivering volumes equal to from 480 to 720 gallons per minute against

pressure heads varying from 95 to 130 feet. Thus it will be noted that with a loss of efficiency of 3 per cent. below the maximum of 72 per cent., an increase of head equal to 10 per cent. will decrease the capacity 15 per cent. at constant speed; and with a constant head, an increase of speed equal to 10 per cent. will increase the capacity of the pump 15 per cent., and a decrease of speed equal to 5 per cent. will decrease the capacity 15 per cent.

In the general practice followed in the construction of high-lift or turbine centrifugal pumps, however widely many makers may differ in important details, it must be conceded from the foregoing that all agree in the expediency of utilising the increased efficiency to be derived from adopting the diffusion vane or turbine principle, the endeavour in all cases being to minimise as far as possible internal resistance by avoiding abrupt changes in direction of the water flow, and by maintaining the flow at an equable rate right through the various stages of the pump at a continuous velocity not exceeding under normal conditions from 5 to 7 feet per second. An examination of the diagrams shown by Figs. 290, 292, and 294 will sufficiently emphasize this loss in efficiency that accrues from over-forcing a pump beyond its designed capacity. There remains, apart from the accepted and limiting practice that can be profitably followed in the combination of the essential elements constituting a pump of this class—after allowing for the influence of bias and the desire to obtain an equally effective or surpassing result by an improved means—considerable differentiation in the form, construction, and arrangement of the diffusion passages from one impeller to another; the principal factor influencing this variation being undoubtedly the necessity for balancing the difference in pressures at the two ends of the pump.

The method adopted for compensating difference in axial pressure in the "Invincible" pump (see Fig. 284) is by providing each impeller with water inlet passages on both sides; and in the "Sulzer" pump (Fig. 285) by a radial disc connected up to the delivery or pressure end, a similar method being adopted in the "Allen" turbine pump, in which there is a radial disc arranged at the delivery end, but placed in communication with the atmosphere or suction pipe; in the "Worthington" pump (Fig. 289), each impeller is provided with a balancing piston, while the practice followed in the "Mather & Platt" pump (Fig. 291) is to use one balancing piston at the suction end, and arranged to be in adjustable communication with the pressure end of the pump; in the "Escher-Wyss" pump (Fig. 293) end thrust is taken up by a ball bearing, and in the "Davey" and "Hayward-Tyler" double pumps (Figs. 287 and 288) two sets of impellers and suction inlets are employed, each set communicating with one central delivery vortex. Then, again, in the Victoria (Orten-Boving) turbo pumps, a balancing piston (*p*), *vide* Fig. 295, is arranged at the pressure end, and in such manner that pressure flow leaking past the balancing piston into the chamber (*l*) returns to the second stage of the pump, and, in consequence of this, the gland (*g*) is only subjected to a comparatively low pressure.

There are, however, factors other than that of end balance to be considered in the construction and working of a multi-stage centrifugal pump, to wit, facility for sectioning-up to meet the varying requirements of pressure head, for instance, there is in general practice only one series of sections used in order to minimise length and cost of construction; also when used for mining and other purposes wherewith abrasive solids are carried through with the water, there is the additional question of increased wear and tear to be provided for, and, in consequence of this, the selection of a pump in which pressure-loss from one stage to another will be least liable to increase with use; under which cir-

cumstances facility for the renewal of impellers, guide rings, bearings, and balancing pistons takes precedence over others.

In regard to the field of usefulness to which the turbine series centrifugal pump can be applied, it may be said that this may include practically every purpose and any volume or pressure head, wherewith such a pump can be directly driven from a high-speed motor. There is one inherent advantage peculiar to its type that cannot be over-rated—viz., that of being entirely free from causing fluctuation in the delivery main, and is for this reason adapted for boiler-feeding; yet another point may be adduced in its favour when applied for the purpose of supplying water to a reservoir, as in this case the use of

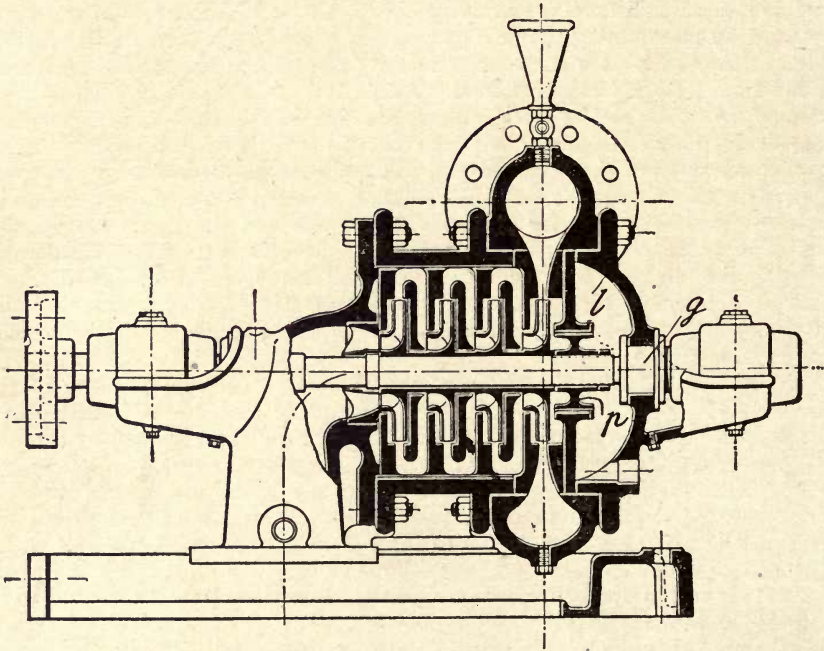

Fig. 295.—Sectional Elevation of Four-stage Victoria Turbo Pump.

a float control at the delivery end automatically regulates the output of the pump without need for any connecting mechanism with the power supply. But in regard to the design and construction of a pump of this class, there are so many variable factors that may be and are introduced—viz., in the ratio of diameter of impeller to speed, together with differences in the disposition and curvature of the diffusion vanes—that obviously every make of pump will have inherent peculiarities of its own, and on this account it is only from actual working tests of one of these that really useful formulæ can be deduced that will apply to variations of each particular type.

CHAPTER XIX.

HYDRAULIC POWER WHEELS.

Overshot, Breast, and Undershot Water-Wheels.

IN the utilisation of the force of water as derived from pressure head for the generation of power, the earliest means adopted is not definitely known, but was probably some form of paddle-wheel, adaptations of which are of various types, and those the most extensively used, and characterised as overshot, breast, and undershot water-wheels, are of the kind diagrammatically illustrated by Fig. 296. In overshot wheels, which are only adapted for falls ranging from 10 to 60 feet, the energy is derived mainly from gravitation effect, although some advantage is obtained from the stream feeding the wheel in producing a certain degree of kinetic energy. Overshot wheels require a depth of level of tail race somewhat exceeding the diameter of the wheel to permit of the vanes, paddles, or buckets running clear of the tail water at highest flood level, and indeed, in order to obviate the retarding effect of running in back-water, wheels of this type have been arranged with the direction of flow to the wheel reversed, so that the direction of rotation of the buckets on the underside shall be the same as the tail water. The peripheral velocity of either type of wheel is about one-half that of the water after leaving the sluice gate, and usually does not exceed 6 feet per second; and in order that an efficiency exceeding 50 per cent. may be obtained it is important that the vanes forming the buckets shall be at such an angle to the tangent (usually from 15° to 20°) that the water may leave the wheel at the lowest point; further, in the case of wheels, as shown at (1), that this should not commence until within 40° of the perpendicular, the less the dimension (l) provided water is not projected underneath the wheel the higher the efficiency. In general practice the depth of shrouding (k) is about 12 inches, with bucket vanes in wood, and 16 inches with curved iron vanes, as shown, the pitch being equal to the depth.

Breast wheels avoid carrying the water in a direction opposite to the inflow, and are for this reason more efficient; they, moreover, do not require a difference of level between the head flow and tail flow exceeding three-fourths or so that of the wheel diameter. In wheels of this type—*vide* (2)—water is supplied by a sluice (s), and is fed through openings (p) controlled by a gate (t) to curved sheet iron "Fairbairn" ventilated buckets (b), the action of this wheel being such that the water can be all carried forward to within 10° or 15° of the perpendicular, and leave it at the lowest point, by reason of the apron or curved masonry work (a); water should be admitted at a level not exceeding 30° above the horizontal, the best position being within 10° above or below, according to the relative diameter of wheel to difference of head and tail levels (h); and owing to the retaining apron (a) the angle of the bucket vanes (b) may be 25° to 35° with the tangent, and for the same reason the depth may be increased to 20 inches.

Undershot wheels have the advantage over other types in their adaptation for very low falls and shallow streams, and have been used since remote times in their simplest form with flat paddles; the first improvement on this was made by Smeaton, for use in working mine unwatering pumps, these having been constructed with wood paddles or bucket vanes inclined at an angle of about

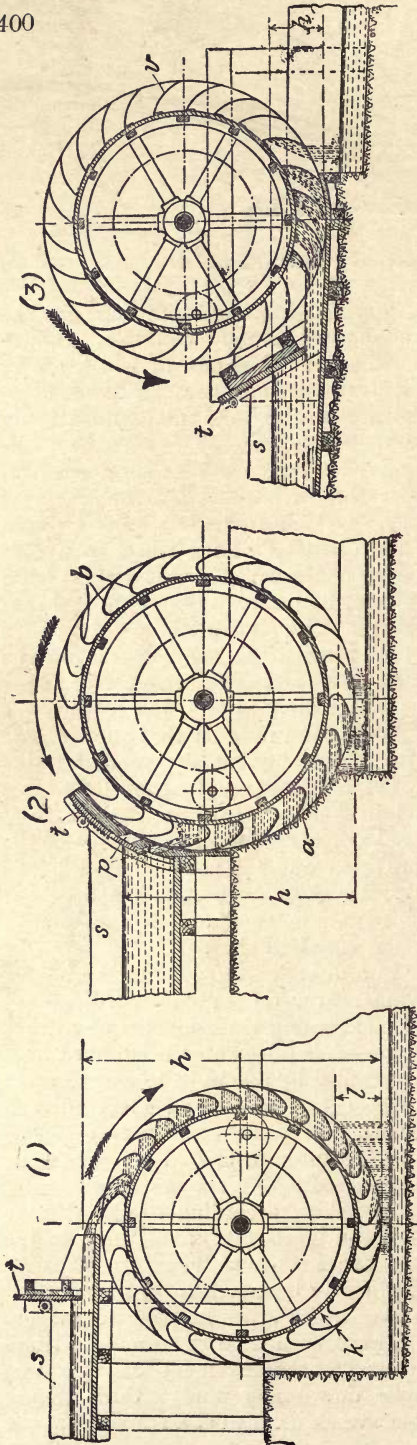

Fig. 296.—Sectional Arrangements of Overshot, Breast, and Undershot Water-wheels.

TABLE SHOWING CHARACTERISTICS OF OVERSHOT, BREAST, AND UNDERSHOT WATER-WHEELS.

Type of Wheel.	Suitable for Falls in Feet.		Efficiency.*		Circumferential Velocity in feet per Second.	Diameter of Wheel.
	Maximum.	Minimum.	Highest.	Lowest.		
Overshot,	60	10	65	40	6	Feet. 10 to 60
Breast,	40	10	75	50	8	16 to 30
Undershot,	10	2	60	30	0.55 $\sqrt{2gh}$	10 to 20

* This does not include losses in gear transmission.

60° to the tangent; the efficiency of these wheels never exceeded from 30 to 40 per cent. until the substitution of the old form of flat vane for curved Poncelet vanes, such as shown in the illustration (3). The height of fall from which the best results can be obtained in the best form of Poncelet wheels ranges from 6 feet down to 3 feet, their efficiency for very low falls equalling the modern turbine, but, needless to add, are expensive and lose considerably in transmission owing to their slower action. Referring to the illustration, it will be seen that the bucket vanes are curved to the tangent at an angle of from 35° to 40°, which in action effectually absorbs the kinetic energy of the water flow as represented by its velocity 0.75 to $0.80 \sqrt{2gh}$, by reason of the vane curvature, thus avoiding shock and resulting in the water leaving the wheel with but very little horizontal velocity.

Water Power Available.

In the present development of hydraulic power America undoubtedly leads the world, statistics showing that water-power electric installations of that country, already in operation, are capable of generating more than one million horse-power, as against 600 thousand in Canada, 350 in Italy, 300 in Switzerland, 200 in Austria, 300 in Sweden and Norway, 200 in France, 140 in Hungary, 150 in South-America, 60 in Russia, 40 in South-Africa, and in other countries, including Great Britain, which is not particularly favoured with water-falls, India and Australasia, an additional 250 thousand may be estimated—thus together, up to the present, aggregating to a maximum total for the world of nearly three million horse-power, and, needless to add, affords sufficient evidence that hydraulic power is destined to have in the near future a tremendous influence on the prosperity of manufacturing districts, bearing in mind that whereas the generation of power by the consumption of fuel means a total loss to that particular country, not only of interest, but of capital also—the process of combustion not being reversible, and consequently every pound of fuel once burned irretrievably lost—water power, on the contrary, possesses the inestimable advantage over every kind of fuel power in having a complete cycle provided by nature in perpetuity. As an instance of this, it is only necessary to cite one source alone—viz., the Niagara Falls—which provides for a total available horse-power of about 4,000,000, and continues, without interruption, from year to year with only an annual variation in level above the Falls of about 3.5 feet to discharge over a quarter of a million cubic feet, or 6,000 tons of water every second of time. The permanence of this tremendous flow of energy is secured by reason of the difference in the levels of Lake Erie and Lake Ontario, which Niagara connects, being as much as 326 feet along a distance of only 30 miles, of which the rapids above the Falls account for 56 feet, and the Falls themselves 160 feet. Besides these, other extensive falls have been discovered in South America, while in the North several additional important sources of water power may be appropriately mentioned, such as the Shawingan Falls, Quebec; the Trenton Falls, New York State; and the Snoqualmie Falls, Washington; in addition to which thousands of falls are available, and to be found in almost every quarter of the globe, suitable for affording water power varying in capacity from 10 H.P. upwards; the largest of all being the Victoria Falls on the Zambesi, where a volume three times greater than that of Niagara falls a sheer 400 feet, and represents at the present time a total absolute waste of power of close on 20 million horse-power.

Various Types of Turbine Wheels.

In the utilisation of hydraulic energy for all powers, both small and great, generators constructed to work on the turbine principle have now entirely superseded the less efficient and comparatively cumbersome water-wheel; and it requires but very little reflection to realise the impracticability of harnessing falls much exceeding 100 feet by this means. The evolution of the turbine extends back some 50 to 60 years, although the manufacture of various types of water-wheels did not cease until within the last 15 years or so, and during this time the form and design has passed through many changes to suit varying conditions and pressure heads, but may be generally classified into two types: the "reaction" and "impulse" turbines, according to the method of applying the hydraulic energy for the generation of power.

In turbines of the reaction type, known as (1) parallel flow or Jonval, (2) vortex or Thomson, (3) diagonal flow or "Francis," the flow of water should be continuous in all the passages of both guide ring and impeller; turbines of this class are, therefore, adapted for being worked in connection with a draught tube and with tail suction, or to discharge below the tail water level. In turbines of the impulse type, such as the "Girard" and the high-pressure tangential, or spoon wheel, known as the "Pelton," and in the class known as centrifugal, outward flow or "Founeyron," the buckets or spaces between the impeller vanes are only partially filled by the water passing through them, the atmosphere having free access to the space not occupied by water. The first-named class may be further subdivided, as regards their construction, into radial, axial, parallel flow, mixed, or diagonal flow turbines. In those of the radial class, the water flows through the impeller at right angles to the axis of rotation in either an outward or inward direction, and are characterised as centrifugal or vortex turbines respectively. In axial turbines the direction of flow is parallel to the axis of rotation, which is generally arranged vertically; and in turbines coming under the generic term composite, mixed, or diagonal flow, the water enters radially and discharges axially. The different types of reaction-wheel turbines that are now in one form or another principally used for comparatively low-pressure heads, although extensively used also in large sizes for falls exceeding 150 feet, in combination with discharge suction tubes, are commonly known by the names of their respective inventors: Axial or parallel-flow turbines, for instance, as Jonval (period 1840 to 1890); radial inward flow, or vortex turbines, as Thomson, and made for falls under 400 feet, in sizes up to 200 H.P. A modification of the parallel flow variety, known as conical or Escher-Wyss turbines, and constructed until recently in sizes exceeding 1,000 H.P. for falls under 50 feet, this type now being superseded by the diagonal or mixed flow form of impeller wheel, first introduced by J. B. Francis, of America, in 1890, and now universally adopted by many makers for even very large powers, as will be shown by the several examples adduced later. Mixed flow turbines for low-pressure heads, with or without casings, are variously known as "Samson," "Victor," "Lundal," etc., the several makes of this type of turbines being specialised according to the particular method of governing adopted. These turbines are generally constructed with fixed guide vanes, between which and the impeller wheel is fitted a cylindrical sliding sluice connected up to a hand or automatic controlling gear, and the larger sizes, with swivel vanes, arranged to be actuated synchronously by a governor controlled ring. Reaction diagonal-flow turbines are constructed with single or double discharge draught tubes, with horizontal or vertical driving shafts, and in sizes ranging upwards from 10 to 15,000 H.P., and for all pressure heads not exceeding 300 feet.

The principal advantage of the "Francis" or radial-axial-inflow turbine over the "Thomson" or radial-inward flow turbine, sometimes known as the vortex, accrues from its greater volume capacity owing to the discharge being continued near to the centre, thus enabling an impeller of smaller diameter to be used than is required when discharging at right angles to the axis.

Theoretical Aspects of Hydraulic Power.

Before proceeding, however, to describe examples illustrative of the best-known types of reaction turbines, it will be useful at this juncture to first consider some of the principles involved in their construction: "Thus each pound of water moving by gravitation effect has (*h*) foot-pounds of energy potential;

the velocity of water in feet per second squared and divided by $2g$, equals foot-pounds of energy kinetic; and $h \times 2.3$ equals pressure energy per square inch."

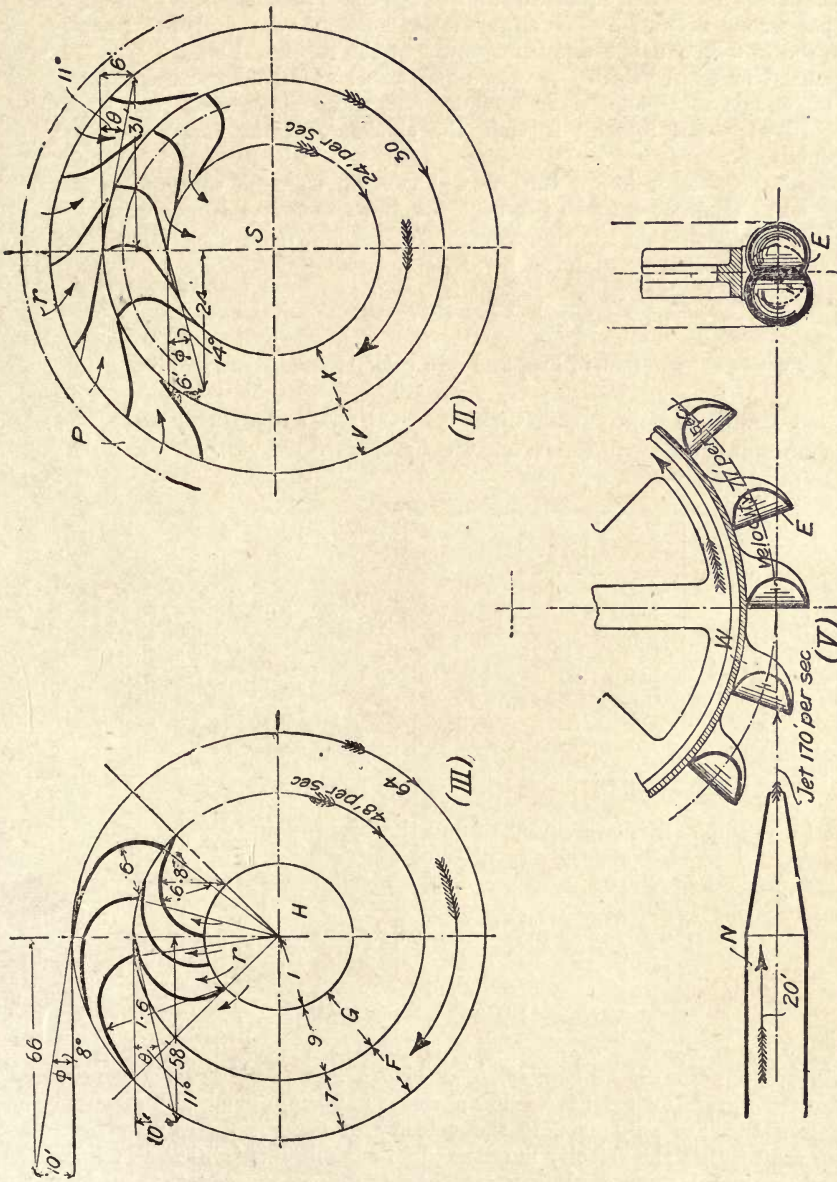

Fig. 297.—Diagrams showing Velocity of Water Flow, Disposition and Angle of Vanes in Centrifugal, Vortex, and Impulse Types of Turbines.

(II.) Diagram of inflow or vortex turbine for 30 feet pressure head.

(III.) Diagram of outward flow turbine for 100 feet pressure head.

(V.) Diagram of jet action turbine for 500 feet pressure head.

The tangential velocity of water flowing from the guide vanes into the impeller wheel should not be less than the peripheral velocity; the radial velocity

of the water flow through the impeller should equal approximately 0.12 the velocity due to pressure head, thus (r) equals $0.12 \sqrt{2gh}$ —*vide* the diagrammatic examples of centrifugal and vortex turbines (Fig. 297); the volume of water flow in cubic feet per second equals the area of the wheel passages $\times (r)$; head \times gallons per second divided by 550 equals water horse-power; and water horse-power $\div 0.8$ to 0.85 equals brake horse-power at the turbine shaft.

Tangential or whirl velocity \times velocity of wheel at inlet surface in ft. per sec. $\div 32$ equals foot-pounds per second; and with 8 per cent. tail waste energy + 12 per cent. loss by friction, the efficiency of the turbine will be 80 per cent.

A reaction vortex or inflow turbine will develop from 80 to 85 per cent. efficiency when allowing 5 to 10 per cent. for tail waste and 10 per cent. for friction, the water entering the runner with a velocity of $0.68 \sqrt{2gh}$, therefore horizontal force exerted by each pound of water is—

$$\frac{w}{g} - v = 0.62 \sqrt{2gh}.$$

where w = weight in lbs., and v = velocity in feet per sec.

TABLE A.—SHOWING TANGENTIAL VELOCITY OF FLOW FROM GUIDE PASSAGES TO PERIPHERY OF IMPELLER WHEEL IN VALUES OF $\sqrt{2gh}$ IN FEET PER SECOND.

Inventor.	Type of Turbine.	Class.	Velocity.
Jonval, . . .	Axial or parallel flow, . . .	reaction	0.65 to 0.68
Thomson, . . .	Inward flow vortex, . . .	„	0.68 to 0.70
Escher-Wyss, . . .	Diagonal flow conical, . . .	„	0.63 to 0.65
Francis, . . .	Inward plus axial flow, . . .	„	0.61 to 0.63
Fourneyron, . . .	Outward flow centrifugal, . . .	„	0.72 to 0.75
Girard, . . .	„ „ „ „ . . .	impulse	0.88 to 0.90
Pelton, . . .	Tangential flow, . . .	„	0.94 to 0.96

Thus, for example, if it is required to find the speed of an impeller 2.25 feet diameter, in an inward flow vortex turbine, to work with a total pressure head of 100 feet, proceed as follows:—

$$0.68 \sqrt{64 \times 100} = 54 \text{ feet per second.}$$

$$\frac{54 \times 60}{7} = 460 \text{ revolutions per minute.}$$

It will be seen from a comparison of Tables A and B that the tangential velocity of the water flow from the guide passages in vortex, axial, and diagonal flow reaction turbines only exceeds the velocity of the runner rim by from 3 to 5 per cent.; that the velocity in outward flow turbines is from 20 to 25 per cent., and in impulse outward flow turbines the flow exceeds the rim by 50 to 60 per cent., and in tangential impulse jet-action turbines the flow should be from 110 to 130 per cent. greater than the mean velocity of the wheel cups.

TABLE B.—SHOWING VELOCITY OF CIRCUMFERENCE OR PERIPHERAL SPEED OF IMPELLER VANES IN VALUES OF $\sqrt{2gh}$ IN FEET PER SECOND.

Inventor.	Type of Turbine.	Class.	Velocity.
Jonval, . . .	Axial or parallel flow, . . .	reaction	0.62 to 0.64
Thomson, . . .	Inward flow vortex, . . .	"	0.66 to 0.68
Escher-Wysss, . . .	Diagonal flow conical, . . .	"	0.62 to 0.63
Francis, . . .	Inward plus axial flow, . . .	"	0.60 to 0.62
Fourneyron, . . .	Outward flow centrifugal, . . .	"	0.58 to 0.60
Girard, . . .	" " " " " "	impulse	0.53 to 0.55
Pelton, . . .	Tangential flow, . . .	"	0.40 to 0.45

In the diagrammatic examples (I. to V.), Figs. 297 and 298, the angle and velocity of flow to the runner wheels of the five different classes of turbines is denoted by θ , and from the wheels to the tail race by ϕ ; from an examination of the action of these several turbine designs, it will be noted that all are more or less reaction as well as impulse wheels, reactionary effect greatly preponderating in I., II., and III.; that the two effects are nearly balanced in example (IV.), while in (V.) the momentum or impulse effect preponderates. In regard to the action of tangential or "Pelton" wheels, as illustrated by (V.), it may be stated that the velocity of a jet issuing from the nozzle N is $\sqrt{2gh}$ —coefficient of velocity—*i.e.*, from .97 to .98—the propelling force of which = $1.95 \times \text{area of nozzle} \times 0.97 v^2$ —*i.e.*, the force of a jet is equal to the weight of a column of water whose base is the area of a jet \times by a height 1.95 that due to its velocity; and the rate of flow in cubic feet per second = area of nozzle in square feet $\times 0.97 \sqrt{2gh}$; also the momentum or impulse effect of a jet flowing from a nozzle per second = cubic feet $\times 62 \times 0.97 \sqrt{2h}$, and the water horse-power = 0.79 to 0.83, the force in foot-pounds per second \div 550 with 10 per cent. tail waste energy.

Although reaction turbines of the type shown at (I., II., and III.) Figs. 297 and 298 are used for pressure heads exceeding 200 feet, this is considered to be the determining limit by many makers for turbines of this class; but jet action impulse turbines (better known as "Pelton" wheels) have a range of pressure head from 100 to 200 feet up to 2,000 to 3,000 feet; this type of turbine has also a wide range of speed, and in its earlier form was known as the Hurdy-Gurdy wheel, a type of turbine first introduced for mining operations in California in 1840, and its action may be better understood from the following data:—Pressure imparted to a plane surface, such as the flat vane of a tangential wheel when held stationary may be expressed in foot-pounds as equalling twice the flow in pounds per second by area of nozzle and height of fall in feet, and is nearly double this when the jet is caused to impinge on a hemispherical or spoon-shaped vane, as used in the Pelton form of free-jet turbine, introduced in 1880. A still better result is obtained in the more modern form of bucket used in connection with the high-pressure free-jet action turbine, this consisting in dividing the buckets W by a cone-shaped ridge E, Fig. 297 (V.), so as to deflect the flow more equally over the surface of the bucket, and thus produce a maximum of reactionary effect, the curvature of the buckets being such that the direction of flow is nearly reversed, so that the water falls inertly from the wheel into the tail race.

Obviously, the tangential thrust is greatest at the slower speeds and

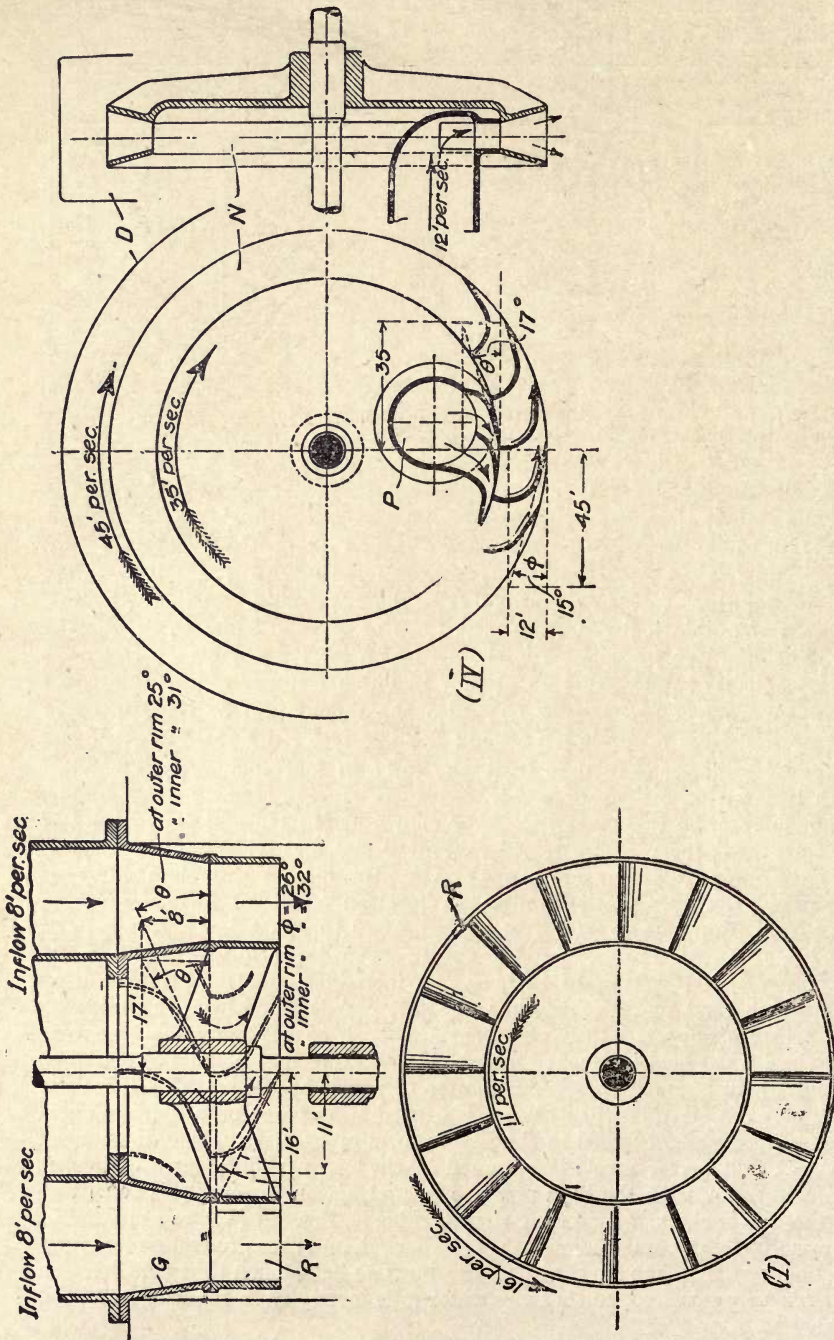

Fig 298.—Diagrams showing Velocity of Water Flow, Disposition, and Angle of Vanes in Jonval and Girard Types of Turbines.
 I. Diagram of parallel flow turbine for a fall of 10 feet. IV. Diagram of combined impulse and reaction turbine with outward flow for a pressure head of 100 feet.

diminishes to zero as soon as the velocity of the buckets exceeds that of the jet, the most efficient velocity being found, as shown in Table B—*i.e.*, from 0.4 to 0.45 $\sqrt{2gh}$, or approximately half that of the jet. The energy thus transmitted in foot-pounds per second is practically cubic feet $\times v^3$; and in a wheel with a moving nozzle, as in a Barker's mill, and in all reaction turbines, the reactionary or propulsive effect due to the outflow of water from the wheel is as: velocity of jet minus velocity of nozzle $\times 1.9$ cubic feet per second.

In diagram I. (Fig. 298), showing a Jonval or parallel-flow turbine for a 10-foot fall, the tangential velocity from the guide ring G at the outer and inner diameters exceeds by about 6 per cent. that of the impeller wheel R, the water falling practically inertly from the underside into the tail race. The Jonval is a type of wheel that was almost exclusively built for low falls, between the period 1840-1870, but from about 1895 its vogue fell off rapidly on the introduction of the Francis wheel, to be referred to again. Jonval turbines are more generally arranged as shown—*i.e.*, vertically—and for falls not exceeding 20 feet, and often for falls of 2 or 3 feet only; one at Strensham Mills, near Worcester, having a diameter of 11 feet to develop 40 H.P. on a total fall of 2 feet. The largest power turbines of this type are in use at the Niagara Falls Paper Company, where four Jonval inverted annular turbines have been installed to drive the machinery through bevel wheels running at a pitch velocity of 66 feet per second, each turbine being designed to generate 1,100 H.P. at 260 revolutions per minute under a flow of 86 cubic feet per second, and a pressure head of 140 feet; in these the single wheel upward flow construction is adopted in order to balance the driving shaft of 10 inches diameter, which, together with the annular impeller wheel of 3 to 4 feet diameter, weighs 21 tons.

In the pressure vortex radial inward-flow turbine diagrammatically illustrated by diagram II. (Fig. 297), the water enters a fixed guide ring V from a spiral chamber at P, fed by the pressure supply; diverging vanes in V deflect the water flow, thence on to a series of vanes in the impeller wheel X, arranged at such an angle as to discharge the water radially into the vortex S. The velocity of inflow at (r) is usually about 0.12 $\sqrt{2gh}$, this being accelerated by the diverging vanes in V to a velocity equal to from 0.68 to 0.70 $\sqrt{2gh}$ —*i.e.*, about 5 per cent. higher than the speed of the outer rim of X, thus this type of turbine is almost totally a reactionary one. The inner rim may either discharge into a draught or suction tube, or below the level of the water in the tail race, the angle θ being of a value to cause the water to discharge at a tangential velocity within 3 to 4 per cent. of the angular velocity of the inner rim. Owing to the action of centrifugal force the velocity of flow from the guide vanes never equals that due to pressure head as in free jet and free deviation turbines, the hydraulic efficiency is, therefore, higher, owing to reduced surface friction. Another effect to be found in all radial inflow turbines is the quality of being to a certain extent self-governing, and in a manner that may be said to be somewhat analogous to that of an electric motor; this rather remarkable effect results from an accelerated flow into the wheel, due to the diminished force opposed by centrifugal action when the speed of the impeller is retarded; thus, at a slower velocity of rotation the reactionary effect increases, and *vice versa*, with an increase in speed there follows a corresponding increment in balancing force, due to centrifugal action. For example, referring to diagram II., the velocity of the outer rim of the runner X in accordance with the formula $0.68 \sqrt{2gh} = 30$ feet per second, and the force opposed by centrifugal action at this speed is equivalent to practically half the pressure due to the total fall,

thus at an acceleration of 50 per cent. the two forces will be balanced and the flow arrested, while if the impeller be held stationary the flow and reactionary force will be augmented 50 per cent. when disregarding coefficients of fluid resistance in both cases.

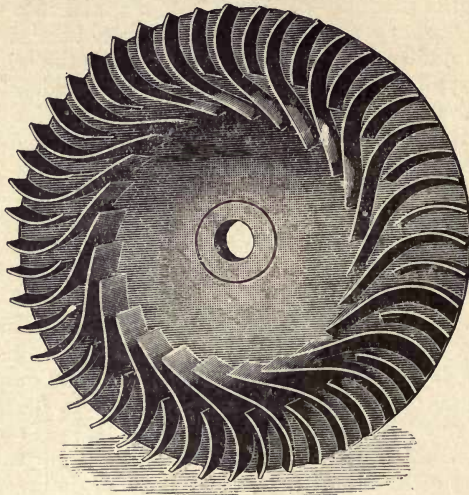

Fig. 299.—Impeller Wheel of Gilkes' Vortex Turbine.

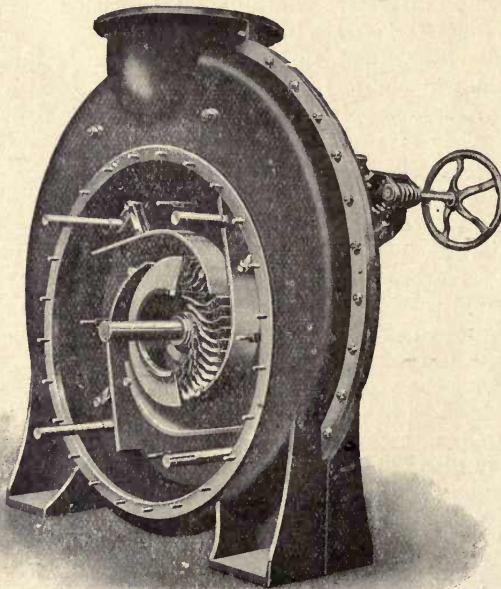

Fig. 300.—View of "Gilbert Gilkes'" Vortex Turbine, with Cover removed showing Swivel-action Guide Blades.

Vortex Turbines.

In the improved form of vortex reaction turbine, shown by Figs. 299, 300, and 301, made by Messrs. Gilbert Gilkes, of Kendal, under the original patent of Prof. James Thomson, the velocity of flow to the impeller vanes is controlled by four movable guide blades *N* pivoted at *V*, and synchronously adjusted by the controlling gear *R* to open or contract the area between each guide blade and the outer rim of the impeller *M*; by this means the velocity of flow can be corrected for varying heads and the speed controlled either by a hand-wheel or governor, as when coupled up to a dynamo or other purpose requiring an absolutely steady drive. Turbines of this type are usually made with a double-draught outflow tube, the impeller, as shown at Fig. 299, having vanes curved as in the diagram II. (Fig. 297), each alternate vane is foreshortened in order to afford the necessary space for the outflow at the inner rim, two sets of vanes being supported one on each side of a central disc, as shown in the cross-sectional view of Fig. 301, and the surface

of each vane made as smooth as practicable to keep down fluid resistance. In some cases the impeller (which is always cast in bronze) is formed

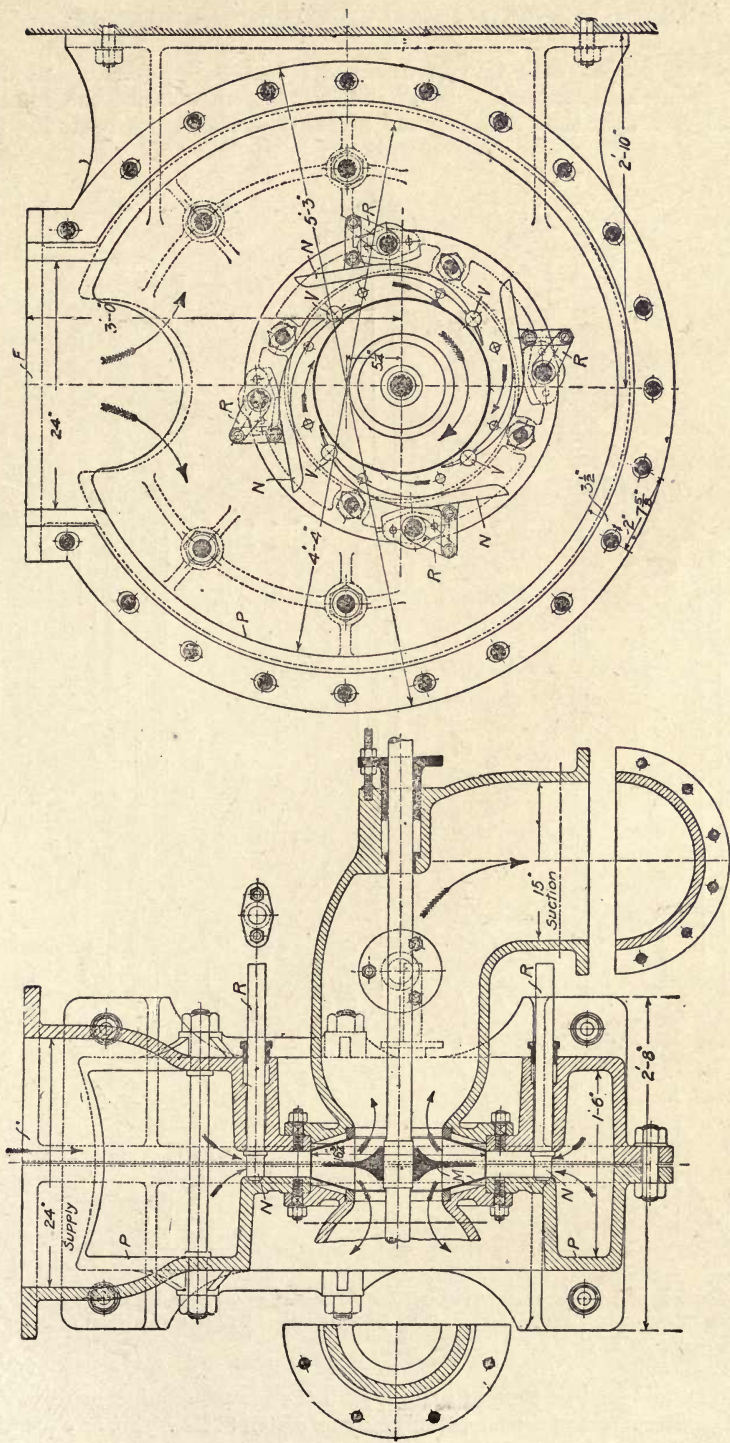

Fig. 301.—Sectional Plan and Elevation of Gilbert Gilkes' Standard Type of Vortex Turbine. Capable of developing 102 H.P. at a speed of 480 revolutions per minute, under a fall of 100 feet, and velocity of 12 cubic feet per second.

with an outer disc at each side in order to reduce side friction, the discs in others being held stationary in the casing; in either case the impeller is balanced endways, thus avoiding the necessity for a thrust bearing. The

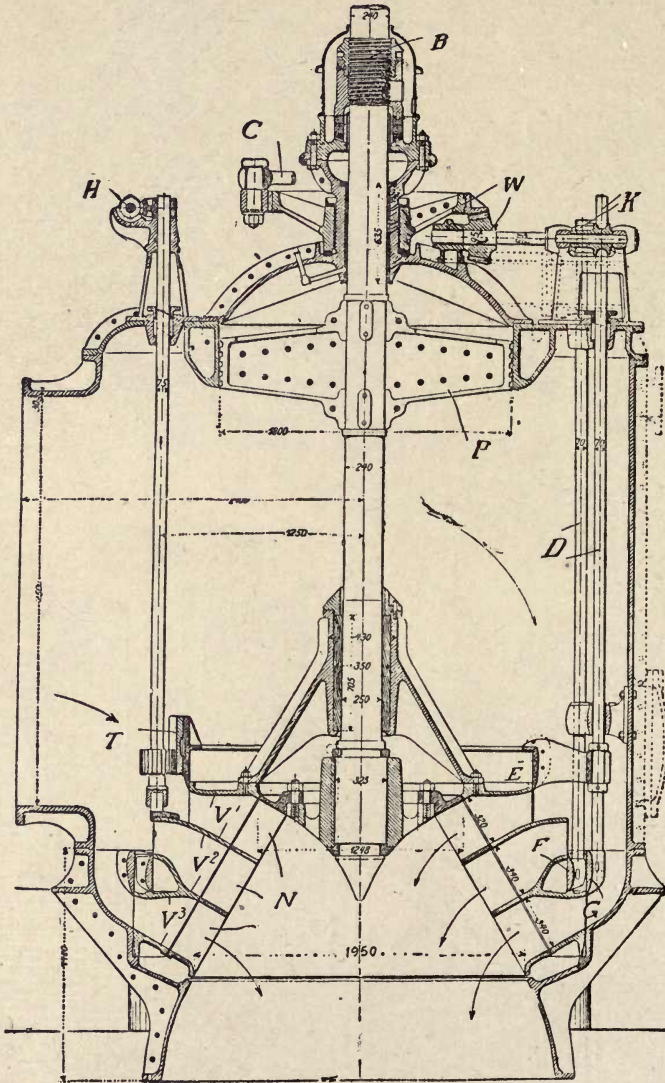

Fig. 302.—Section of Low-pressure Diagonal Flow Conical-wheel Turbine of 1,250 H.P., at 120 Revolutions per Minute, and Fall of 39 Feet, with Triple Cylindrical Sluice Gate Speed Control.

most suitable falls for this type of turbine with the movable guide blades, where economy in water flow is a consideration, may be stated to lie within any pressure

head from 10 up to 300 feet, although for falls below 20 feet a simpler construction with fixed guide vanes is recommended by the makers.

The advantage of turbines of the radial inflow or vortex type is in their simplified form of impeller wheel as compared with the spiral curved vanes used for the more efficient mixed-flow impeller, and is a form of wheel that lends itself for cheaper renewals, and it may be added to greater accuracy in curvature and balance than the latter, but for large powers requiring a considerable volume of pressure water the form of impeller used more often than not combines a more or less pronounced axial flow with that of the radial inflow, for the reason that the point of discharge is brought nearer to the centre with a corresponding increased duty. The evolution and varied application of the mixed-flow impeller may be gathered from the following examples :—

Diagonal Flow Turbines.

In order to obtain a higher power on a low-pressure head as compared with that possible with parallel flow single-wheel turbines without increasing the diameter inordinately, Messrs. Escher-Wyss introduced the diagonal type of turbine, many of which were put down for falls ranging from 15 to 50 feet, between the years 1880 to 1900. In this type an increased waterway and vane area is obtained with a reduced diameter, as will be noted from the example (Fig. 302) designed to develop 1,250 H.P. at 120 revolutions on a fall of 39 feet; the inner diameter of the conical wheel is 50 inches and the outer 78 inches, thus affording a combined length of vane of 40 inches; whereas a parallel flow single-wheel impeller would require a diameter of 11 feet, without allowing for the disparity in the velocities of the inner and outer rims to afford an equal volume of flow.

The weight of the impeller N driving shaft and revolving field of the electric generator E is balanced by the piston P of 72 inches diameter, and water pressure of 16 to 17 lbs. per square inch. A general arrangement of plant consisting of eight of these turbines is also illustrated by the cross-section (Fig. 303), where D is the intake grid, T a stop gate, F the downtake flume, and K the outer casing of the turbine; the pipe N is used to place the upper side of the balancing piston in communication with the draught tube S, the endways alignment of the shaft being further secured by the thrust bearing B.

The method of governing is by the three cylindrical sluice gates E, F, G (Fig. 302), controlling the admission of water to the three guide rings V^1 , V^2 , and V^3 . The three controller rings are operated by three sets of rods terminating in racks K, through the bevel wheel and pinion gear shown at W, the rod and shaft communicating with the oil pressure governor A (Fig. 304), which receives its supply from the pump P (Fig. 303) driven by an independent electric motor. The governing mechanism is shown in section at Fig. 304, and consists of an inverted fly-ball, high-speed governor R driven by the belt pulley B, which controls the admission of oil under a pressure of 200 lbs. per square inch, by the piston valve V to the relay piston P, its movement being communicated to the turbine controller rings through the rod D and gear G. The weight of the controller rings and actuating rods R (Fig. 303) is partly balanced by the upward closing movement of F and by the difference in areas of P and N; and the outward movement of P caused by oil pressure from A (Fig. 304), in displacing oil between P and N back to the accumulator through the branch L closes the three controller sluice rings simultaneously, and on the valve V closing to A and opening to E, the piston P is forced back

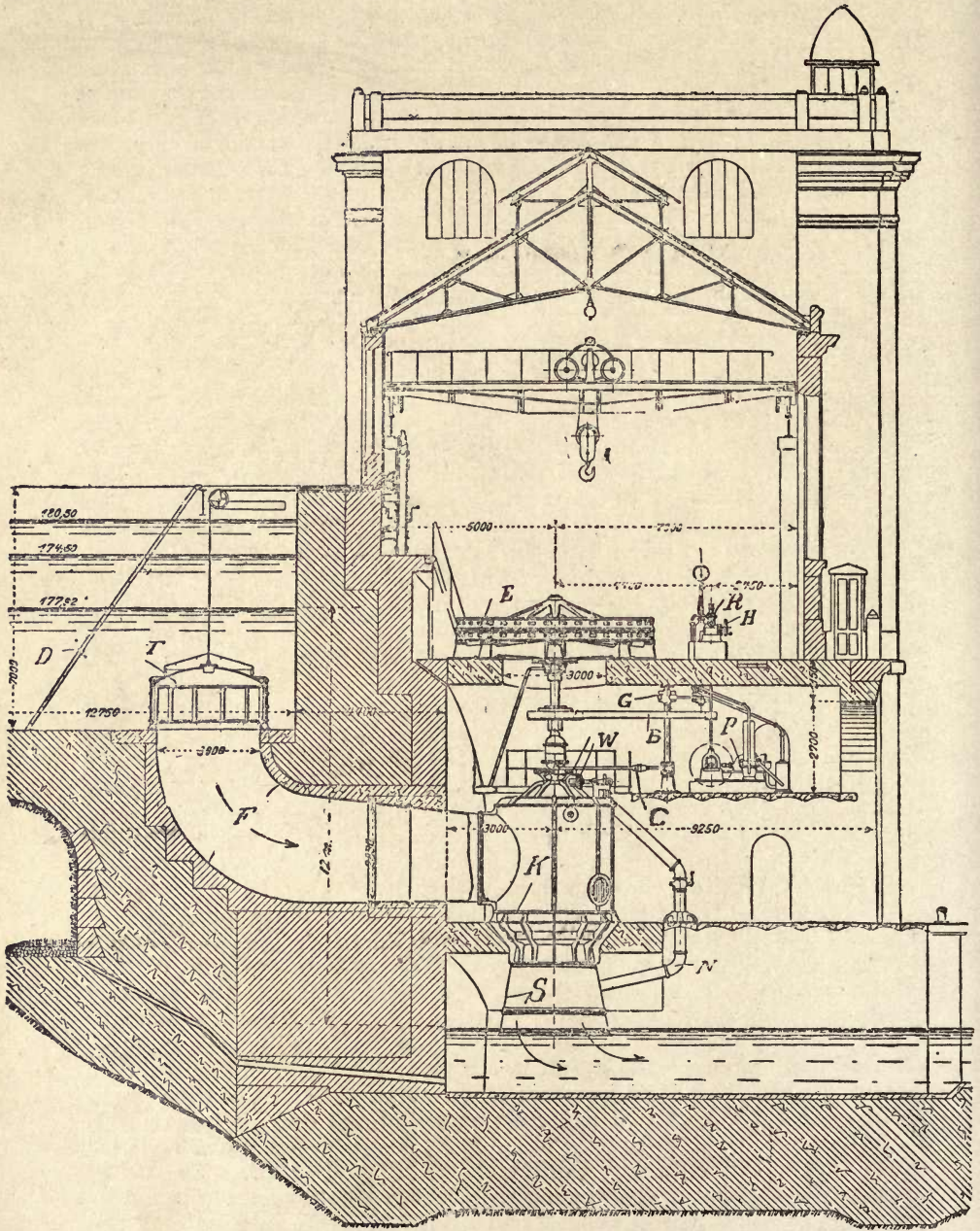

Fig. 303.—Cross-section showing General Arrangement of One of Eight Diagonal Flow Conical-wheel Turbines. (Supplied by the Escher-Wyss Company for the Cusset Electric Power Plant, Lyons, each capable of developing 1,250 H.P., at a speed of 120 revolutions per minute, with a pressure head of 39 feet.)

by oil pressure from L, and again opens the gates. The tendency to hunt is compensated for in a simple manner—*e.g.*, as the relay piston P moves forward it gradually closes (by lowering the fulcrum end T of the governor lever which rests on the wedge Y), the relay valve V admitting oil under pressure to P, until

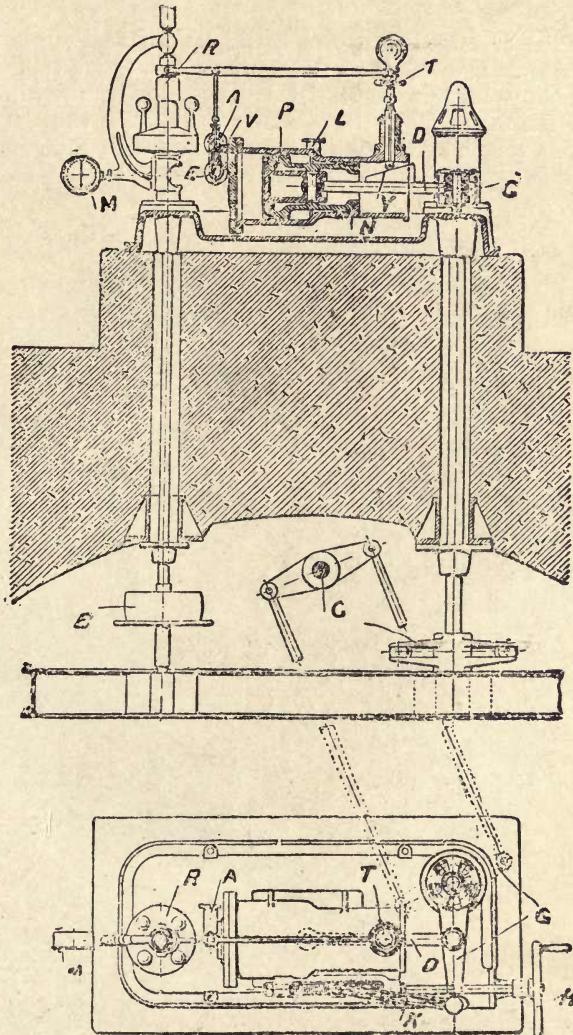

Fig. 304.—Cross-section and Plan of Oil Pressure Governor as used for the 1,250 H.P Conical Turbines at Lyons.

by a further increase of speed pressure is again admitted by the upward movement of R. The extent of the movement of D can be determined by the slot link K and hand-wheel H, and the exact speed of the turbine adjusted by a second wheel under T with the aid of the tachometer M. A subsidiary hand-

controlling gear H and T (Fig. 302) is also used in some cases for varying the relative lead of the sluice ring E to the rings F and G.

Radial-Axial or Mixed Flow Turbines.

In radial-axial or mixed-flow, and better known as Francis turbines, the water under pressure is directed on to the wheel vapes by a ring of either fixed or movable guide vanes in a tangential direction, as illustrated in the diagram II. (Fig. 297), the radial inflow then taking a direction through the wheel in a manner which combines the action of a vortex with that of an axial-flow turbine; by this means the outflow can be continued closer up to the wheel

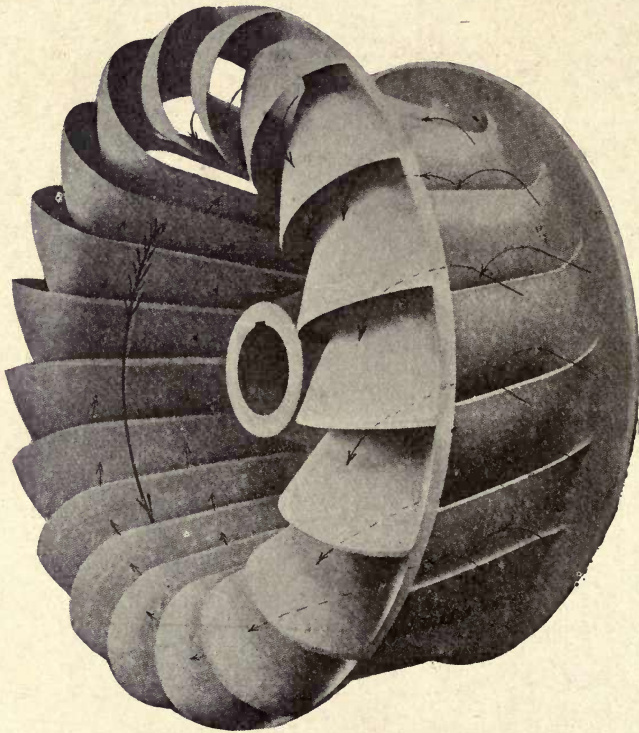

Fig. 305.—Theodore Bell Radial-axial-flow Impeller Wheel for Pressure Heads, 5 to 50 feet.

centre, and a higher duty made possible with a given diameter than can be obtained with either of the forms of impeller yet considered. Owing to the increased duty of the Francis or mixed-flow wheel its advantage for dealing with large volumes of water at comparatively low-pressure heads has been universally recognised, all makers in both Europe and America now adopting this more complex impeller for very low falls in preference to parallel-flow turbines, *vide* diagram I. (Fig. 298); and to the diagonal flow conical-wheel turbines (Fig. 302); and also by most makers to the radial inward-flow type of turbines for falls of great volume under 20 feet head, for which purpose the turbines may

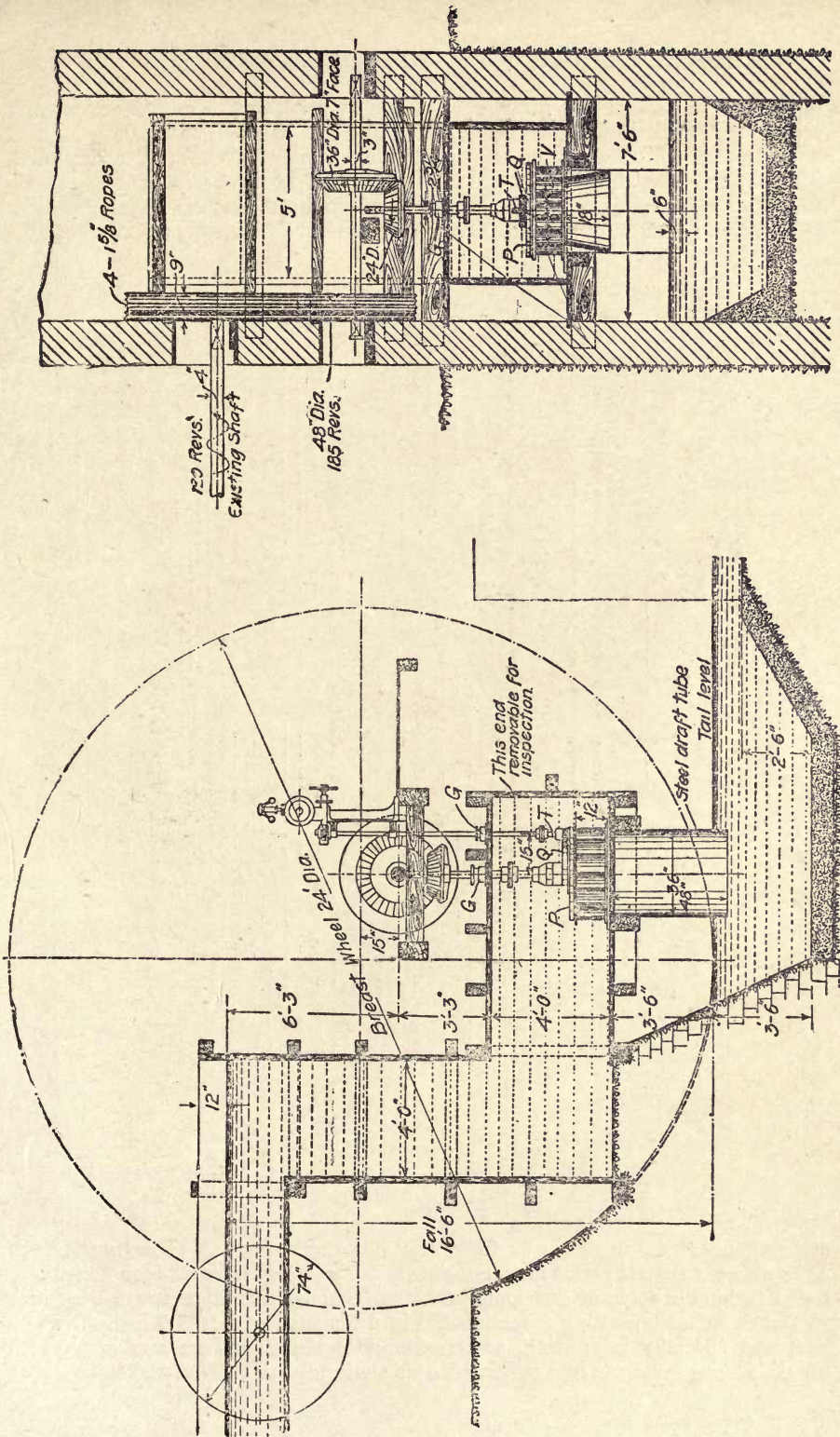

Fig 306.—Arrangement of Vertical 23-inch Samson-Leffel Turbine. (To replace a 24 ft. x 7 ft. breast water-wheel, and to develop 68 B.H.P. on a 16-foot fall.)

be unenclosed and placed in an open flume of brickwork, concrete, or wood construction, examples of such being shown by Figs. 306, 307, and 309.

In the first of these, owing to existing conditions—viz., in order to replace a 24-foot × 7-foot breast water-wheel, the vertical type was decided upon as being the most suitable, the power being transmitted through bevel gearing and a pair of rope pulleys to an existing shaft used for driving the machinery

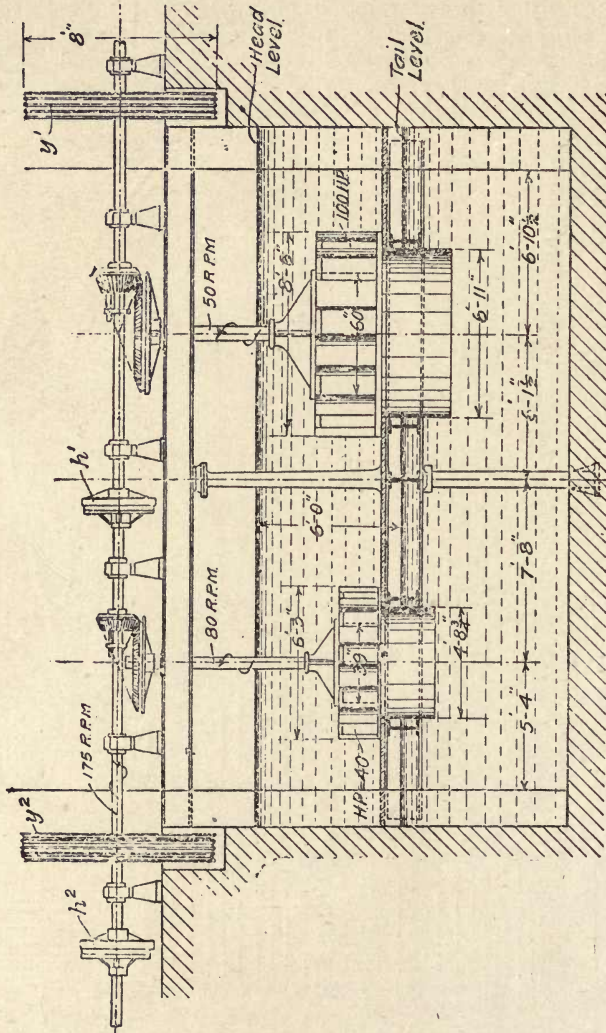

Fig. 307.—Transverse Section showing Arrangement of Inward-flow Turbines at the Electric Generating Station, Newbury.

and dynamo (requiring from 40 to 60 H.P.) at the Ravarnette Weaving Mills, Lisburn, near Belfast; this installation consisting of a vertical 23-inch Samson-Leffel turbine capable of developing 68 B.H.P. under a total pressure head of 16 feet 6 inches (including a suction fall in draft tube of 3 feet 6 inches), will be found specially interesting, as it exemplifies the simple manner in which the conditions requiring in a turbine can be conformed to that of a water-wheel,

in using in the head and tail races, wheel house, and existing shafting with the minimum of alteration.

In the Samson-Leffel turbine the water is directed on to a mixed flow Francis impeller by a ring of swivel guide vanes V (Fig. 306), which are simultaneously moved by a crown of rods P, connecting them with a centrally-pivoted quadrant arm Q controlled by the governor shaft T by means of a sector and pinion in a manner almost identical to the method followed in the Gilkes or Trent turbine (Fig. 300). It will be noted that the turbine is entirely submerged, glands being used for the driving and governor shafts at G, the latter receiving a rotary motion in a forward or backward direction by a fly-ball controlled mechanical relay governor of the King type, to be referred to later. It may be added that this turbine is guaranteed to run with an efficiency of 80 per cent., using 46.5 cubic feet per second, and is capable of developing an additional power of 15 B.H.P. over and above that obtained heretofore with the same volume and fall of water as used for driving the displaced breast wheel. Samson-Leffel turbines of the single-wheel vertical type are supplied in 34 sizes, ranging from 3 to 2,000 H.P., turbines of the same make and characteristics being also constructed in a considerable range of sizes

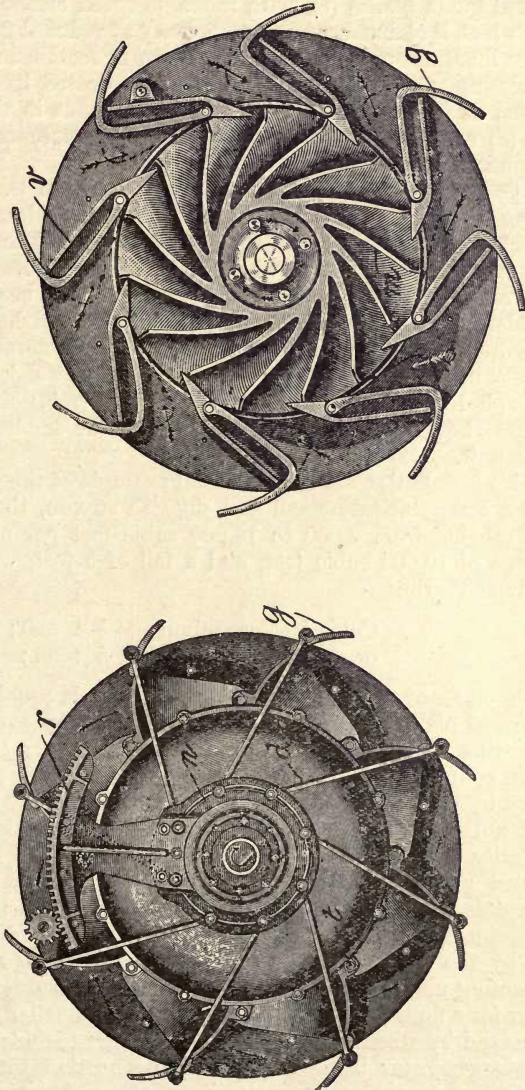

Fig. 308.—Plan Views of 60-inch New American Turbine, showing combination of fixed guide blades with movable speed control blades.

to work horizontally with a central discharge for low falls and with open impellers, and with a double discharge and enclosed impellers for high falls.

As an example in illustration of what can be done by utilising the continuous flow of very low falls of from 3 to 10 feet, such as are available along many of the tributary streams of this and other countries, may be instanced a turbine

plant installed on the River Kennet, in connection with the Newbury electric light and power station, where a pair of mixed-flow turbines (*vide* Fig. 307) are together capable of developing a maximum of 140 H.P. under a fall of 6 feet only. These turbines, known as "The New American," differ from the preceding in the form of the guide ring, there being in this make a combination of fixed guide blades (*v*), with movable speed control blades (*g*), *vide* Fig. 308, from which is claimed a greater efficiency at reduced gate than with swivel vanes. In the illustration, the blades are shown in section in the "full gate" position, the closing movement being indicated in dotted lines; the blades, which are pivoted at (*t*), are simultaneously controlled, as in the preceding examples, by rods (*d*) connected to a movable crown (*n*), actuated by a quadrant rack (*r*) and pinion gear.

The impellers, which coincide very closely to the Francis wheel illustrated by Fig. 305, and as now used by most makers for low pressures, measure 60 and 39 inches respectively across the intake vanes, and are supported by cup-shaped ends on the driving shafts, which rest on lignum-vitæ plugs carried by the draft tube castings. The wear of the wood-pivoted bearing is remarkably small, considering that it has to support the whole weight of the wheel, there being no hydraulic balancing effect. This is the more notable in the case of the larger turbine, in which the impeller and driving shaft weighs nearly 3 tons. The speed, although 15 per cent. less than the rated revolutions, approaches very closely to that shown in Table B—viz., 0.66 for the smaller turbine and 0.64 for the larger unit.

This installation affords a forceful example of the power that can be obtained from a comparatively small and sluggish stream, the available flow during the year ranging from 7,000 to 15,000 cubic feet per minute, which, rated at an average of 10,000 cubic feet, and a fall of 6 feet, works out at approximately 110 W.H.P., thus—

$$\begin{aligned} \text{Cubic feet per minute} \times h \div 550; \\ \text{or, gallons per second} \times h \div 55; \end{aligned}$$

which, on an overall efficiency of 60 per cent. is equal to an output of 66 E.H.P. continued night and day. And as under the system adopted in this and other generating stations of the Urban Electric Supply Company, the turbines are run in conjunction with a battery of accumulators, a larger output than represented by this amount can be drawn upon as required.

A notable feature in the working of an installation of this kind is the automatically and electrically regulated speed control obtained by the series of coupled generator and motor dynamos, which in effect make the provision for automatic control of the water supply to the turbines quite unnecessary. As shown by Fig. 307, the smaller turbine can be disconnected from the larger unit by the clutch (*h*¹), a second clutch (*h*²) being available for the purpose of connecting up an 8 feet by 12 feet breast wheel originally put down to provide power for a flour mill. The breast wheel and smaller turbine can be run together as a stand-by when overhauling of the larger turbine may be required, a second electric generator being installed in connection with the driving pulley (*y*²). In addition to the water-power installation, there is at this station a self-contained gas power plant, consisting of a 250 H.P. Campbell 4-cylinder (17 by 19 inches) vertical gas engine, and direct-coupled generator arranged to be driven from a Daniels anthracite pressure producer, for the purpose of meeting future extensions in the supply of light and power over and above the capacity of the turbine plant.

Wherever the conditions will permit, a horizontal turbine is preferable to a vertical, from the point of view of fixing down, accessibility, and method of drive, and can be placed at a level just sufficiently low down to ensure its being drowned at low water, for pressure heads not exceeding 30 feet. Horizontal, as well as vertical low-pressure turbines are usually uncased, as shown in the preceding example, and as illustrated by the elevation and plan arrangement (Fig. 309) and photo view (Fig. 310), both of which may be fixed in an

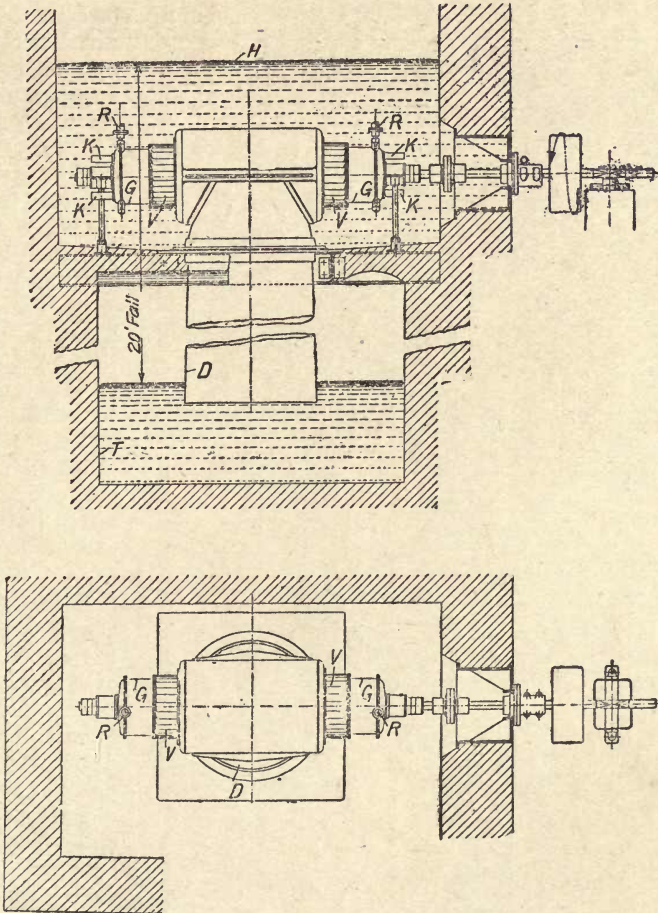

Fig. 309.—Elevation and Plan of 24-inch Twin Diagonal Flow "Victor" Turbine, with cylindrical gate control to develop 120 H.P. at 225 revolutions per minute under a fall of 20 feet. Volume of discharge at 80 per cent. efficiency = 66 cubic feet per second.

open flume formed with masonry or wood work, as shown, where the difference of level, as for instance, in the tail race T, and the head race H, is utilised by the draft tube D, receiving the down flow from a pair of mixed-flow Francis impellers such as illustrated by Fig. 305, the twin construction being adopted partly in order to keep down the diameter and partly to balance the end thrust

of the two impeller wheels. The method of governing may either be effected

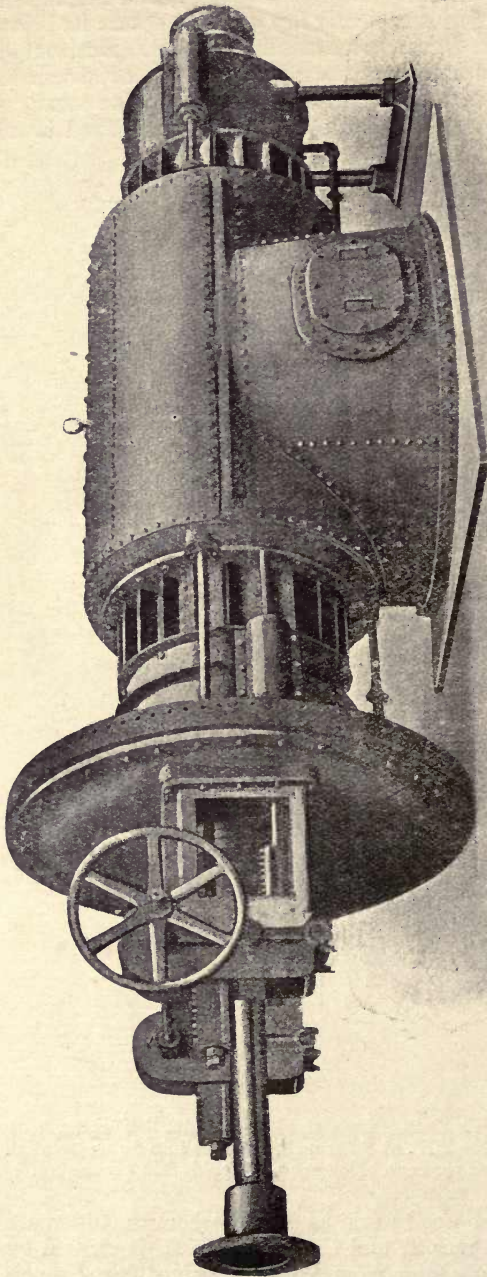

Fig. 310.—Photo-view of Platt Iron Works "Victor" Low-pressure Central Discharge Turbine, showing racks for operating the sliding cylindrical sluice gates.

by means of movable guide vanes as adopted in the Samson-Leffel, and Lundale twin central discharge turbines with open impellers, or by a pair of cylindrical sluices arranged to slide between the impellers and the two rings of guide vanes. In the "Victor" turbine the latter method is adopted, the sluice gates being operated by vertical governor shafts R, engaging with racks K (in the photo view the racks are shown operated by a horizontal control gear), which actuate ring sluice gates within the casings G, that can be in this manner moved endways, so as to regulate the flow from the unenclosed intake guide passage V to a pair of "Francis" impellers, both discharging axially to the central draft tube D, a disposition that permits of perfect end balance and one generally adopted for horizontal low-pressure turbines.

A special interest attaches to the radial inward-flow turbine illustrated in cross-section, elevation, and detail views by Figs. 311, 312, and 313,

owing to the modified form of Thomson-Francis impeller used, and to the fact that this is probably the largest single-wheel horizontal turbine of any type in existence.

and to the fact that several considerations of practical importance are clearly set forth in these fully-dimensioned drawings. One of these single-wheel inflow turbines has been installed at Snoqualmie Falls, Washington, U.S.A., for the Seattle and Tacoma Power Company, by the Platt Iron Works Company, of Dayton, Ohio—the makers of the "Victor" turbines—to develop 10,000 B.H.P. at a speed of 300 revolutions per minute under a head of 260 feet, which on test

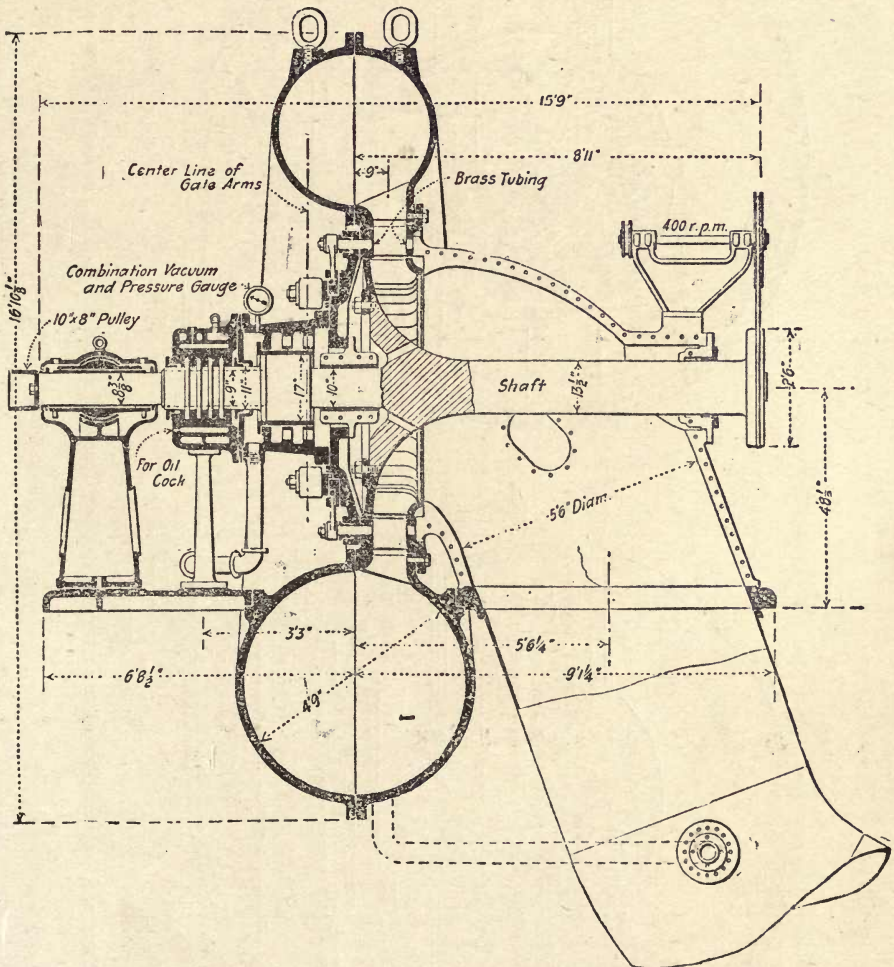

Fig. 311.—Sectional Elevation of Single-wheel Radial-axial-inflow Horizontal Turbine. (Supplied by the Platt Iron Works Company to develop 10,000 H.P. on a pressure head of 260 feet at Snoqualmie Falls.

has recorded a maximum calibrated electric output of 8,250 kw., or an equivalent of 11,000 B.H.P. at an overall efficiency of 75 per cent. The dimensions of this large unit are—Impeller outside diameter, 66 inches by $9\frac{1}{2}$ inches wide, with 34 vanes extending a short distance inward beyond the end plate of the

wheel on the discharge side, and is thus seen to approach as nearly the form of impeller, characterised as mixed or diagonal flow, as the purely radial inflow form of wheel. The speed control as in most modern turbines of this type is on the swivel guide vane, or "Fink" system, in which all the vanes (32 in number) are moved simultaneously by the partial rotation of an exterior ring (shown in Figs. 312 and 313), under the control of a pressure relay governor, as shown

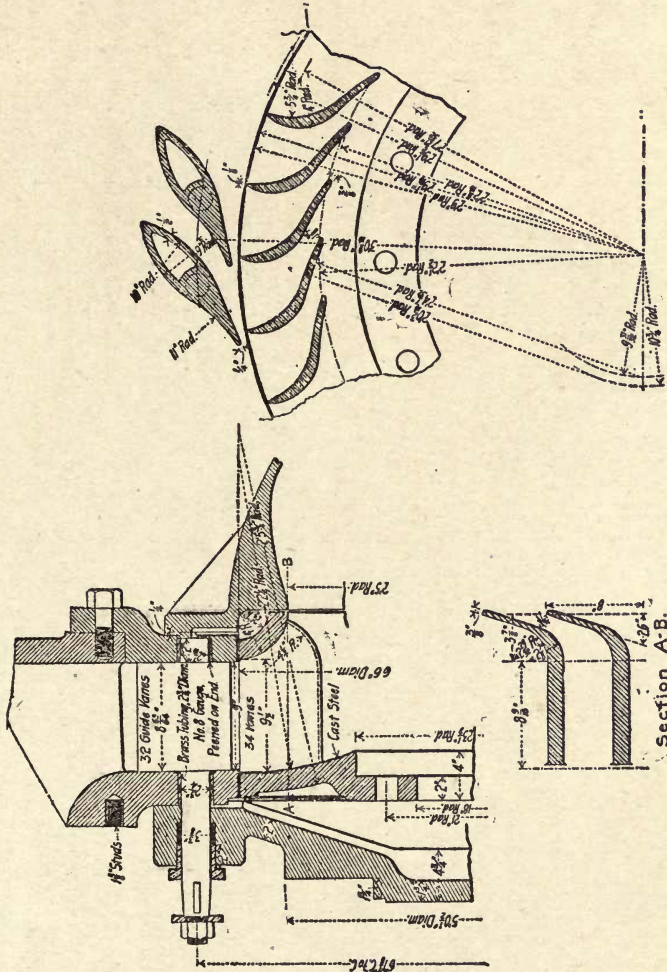

Fig. 313.—Details of Swivel Guide Vanes and Impeller for 10,000 H.P. Single-wheel Turbine.

in the photo-view (Fig. 314). Each individual guide vane is connected by an arm projecting radially inward to the governor ring, which is made rotatable and concentric with the turbine shaft, details of this construction being clearly shown in Fig. 313. The impeller wheel is an annular steel casting, whose radial depth is determined by the depth of the wheel vanes—i.e., 10 inches—and is bolted direct on to a conical enlargement, 46 inches diameter, of the nickel steel driving shaft, proportioned as 13 inches diameter at the electric generator

end, and $8\frac{3}{4}$ inches diameter at the rear end, and having a total length of 15 feet 9 inches.

The peripheral speed of the impeller is 85 feet per second—*i.e.*, $0.66 \sqrt{2gh}$ —

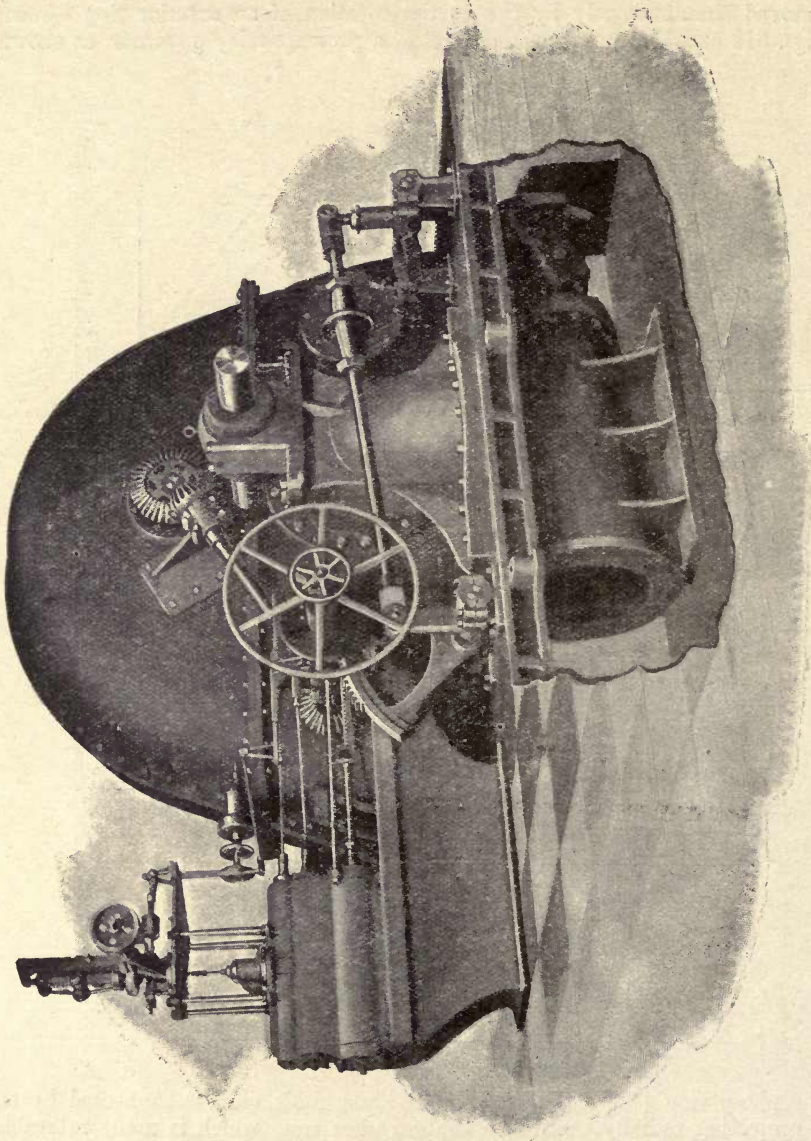

Fig. 314.—Photo-view of Platt Iron Works "Enclosed" Turbine with Pressure Relay Governors.

the vanes of which, as in other radial mixed-flow turbines for high-pressure heads, do not extend towards the centre nearly as far as in the case of low-pressure built-up wheels, the efficiency of the wheel being thereby in some degree sacrificed to considerations of construction. The tendency for the impeller to

be forced away from the discharge tube by the reaction of the radial-axial flow is in part resisted by a balancing piston 17 inches diameter, and forming part of the shaft, as shown located immediately to the rear of the end plate, the space between the balancing piston and the shaft being placed in communication with the pressure flume, and the space between the piston and the end cover with the discharge tube. This means is found to effectually compensate for any difference of pressure on the front and back of the impeller, which varies slightly according to the volume of water passing through the turbine; to correct this difference caused by variations of gate opening—the pressure acting in a direction towards the draft tube preponderating at reduced gate, and away from it

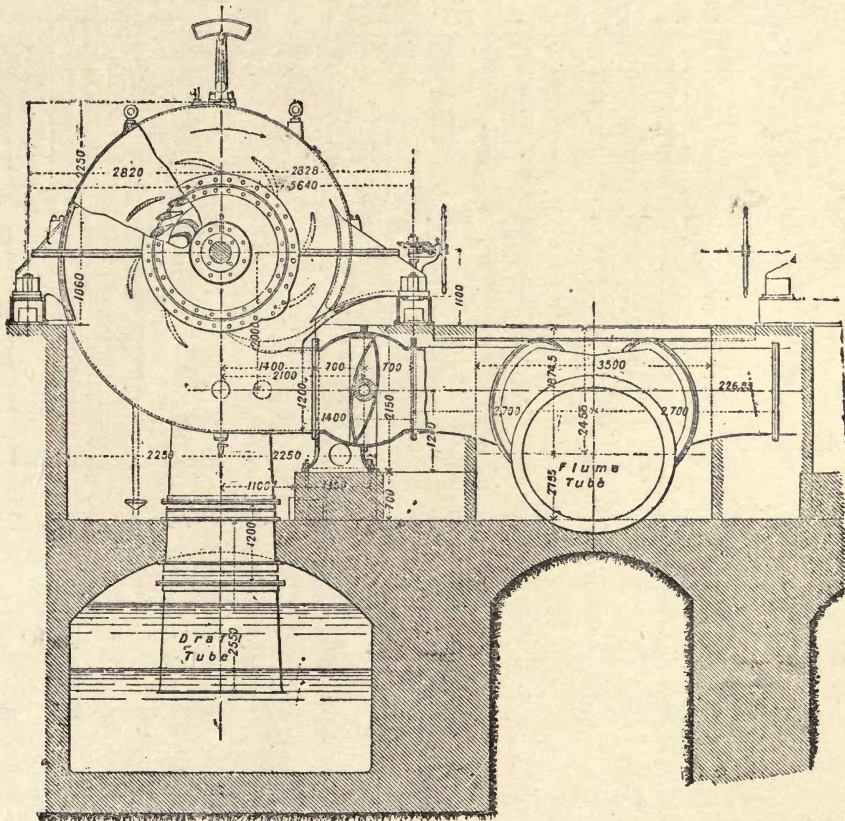

Fig. 315.—Elevation of One of a Pair of Single-wheel Radial axial-inflow Horizontal Turbines, supplied by Ganz & Co., to develop 2,000 H.P. on a pressure head of 90 feet, at Valtellina, Italy.

a full gate—the pressure supply from the flume to the annular space at the left of the balancing piston is under throttle control. The pressure in the space at the back of the impeller between it and the end cover is equalised with that at the front by ventilating openings, and the correct alignment of the shaft endways assured by a thrust bearing. The spiral or vortex chamber of this turbine is built up in six sections, and has a maximum diameter of 17 feet, with

a flume inlet 5 feet 3 inches diameter, and discharge outlet 5 feet 6 inches diameter arranged at an angle of 20° to the vertical.

The illustration (Fig. 315) represents a part sectional elevation and plan of one of four radial mixed-flow turbines of similar construction that are being worked to furnish power for the Valtellina high-tension 3-phase electric railway situated in the North of Italy, particulars of which are as follows:—The total minimum horse-power is 9,100 (equalling 7,000 B.H.P.), and is derived from the River Adda, the water being taken in from a grating 3 feet below the surface for the purpose of excluding debris and floating ice, whence the water enters

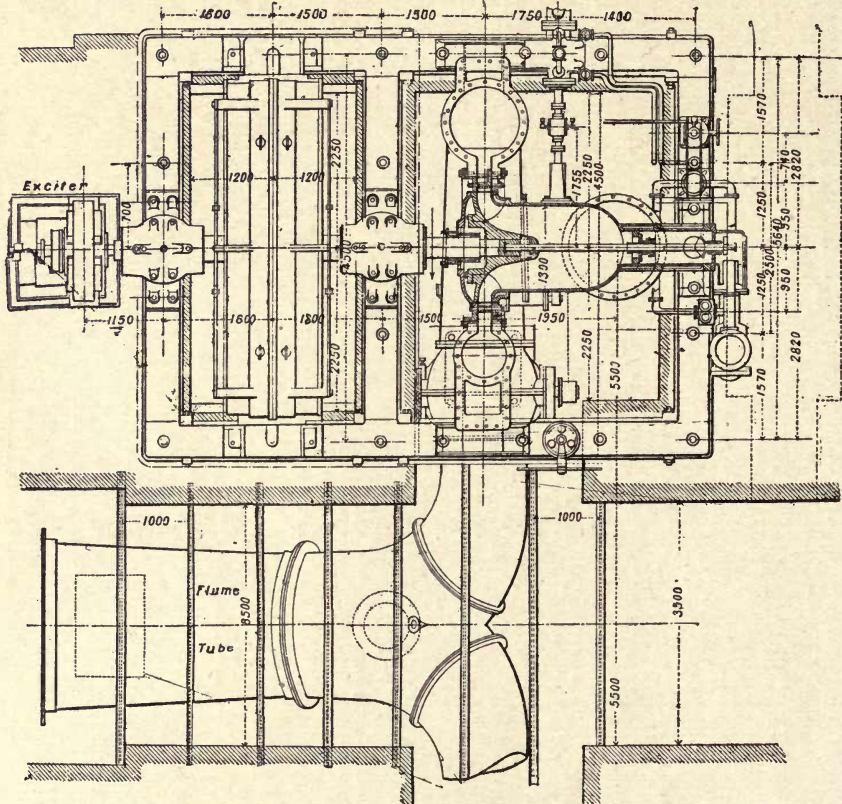

Fig. 316.—Plan of Turbines shown in Fig. 315.

two steel flumes, 8 feet diameter by 210 feet long, the total fall from the top level to the tail race being 90 feet; each of the two flumes terminates in two branches to supply two pairs of turbines, as shown by Figs. 315 and 316, and coupled direct to electric generators.

The turbines, which are each capable of developing 2,000 B.H.P. at the normal speed of 155 revolutions per minute, have impellers 63 inches diameter, and, therefore, a peripheral velocity equivalent to $0.56 \sqrt{2gh}$. The pressure flow which enters the wheels through swivel guide vanes is discharged in a

direction parallel to the shaft into a draft tube extending downwards 18 inches below the lowest water level in the tail race, which is 22 feet below the turbine centre. The details of the swivel "Fink" guide vanes are shown by Fig. 317,

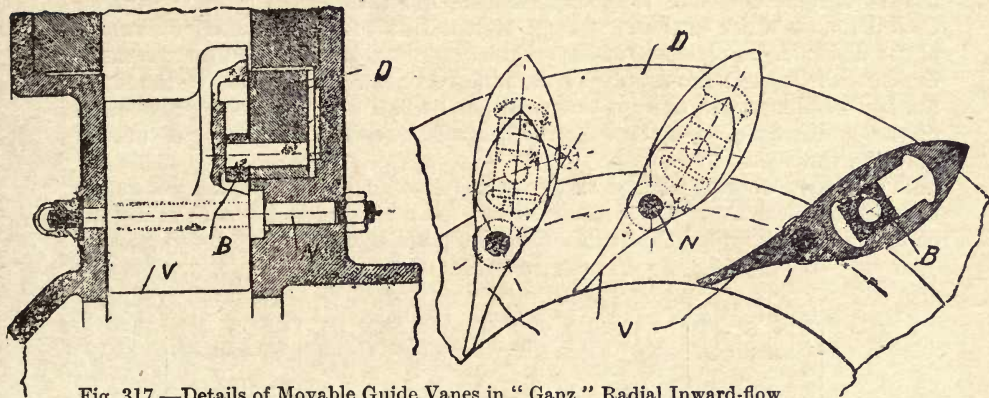

Fig. 317.—Details of Movable Guide Vanes in "Ganz" Radial Inward-flow Turbine.

where V denote the swivel vanes carried by the spindles N, each vane being enlarged on one side and slotted to receive the motion blocks B, actuated by the ring D, which is in turn operated by an oil-pressure governor, as shown by Fig. 318; this consists of a vertical spindle ball governor R, which regulates the admission of oil under a pressure of 150 lbs. per square inch from an accumulator to a double-acting relay cylinder T, by means of a piston valve F and lever D, carried at the governor end by the collar L, and at the movable fulcrum end C by a spindle adjustable in length by the hand-wheel H, and controlled by the opening and closing movement of the sluice ring shaft G, by which means the movement forwards or backwards of the piston S through a small angle is communicated to the ring D, commanding the crown of pivoted guide vanes V. An increase of

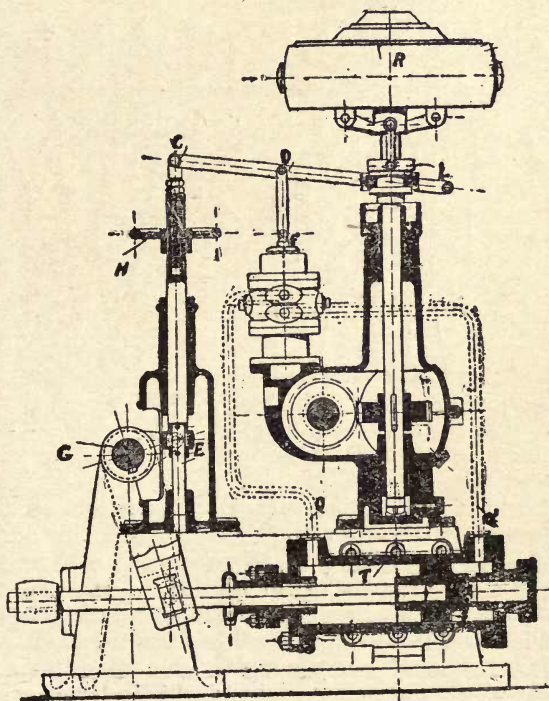

Fig. 318.—Ganz Hydraulic Relay Governor for Reaction Turbines.

speed of the turbine in causing R to ascend lifts D through L and opens F, so that Q¹ supplies pressure oil to S and forces the piston to the left, thus partly closing the vanes V through the gate shaft G and sluice ring; by this movement the lever E is lowered, carrying with it the lever D through C, and thus neutralises the movement of R until a further increase or decrease of speed shall again place one or the other end of the relay piston S into communication with the pressure supply by the pipes Q or Q¹. In addition to the automatic controlling gear, there is the usual hand-wheel for independent regulation of the guide vanes, as well as a screw gear for opening and closing a throttle valve on the main supply flume.

The yearly working cost of this power station, inclusive of upkeep of canal, turbines, generators, and line transmission, is about £3,000 for a total output of 3½ million kilowatt-hours, thus one unit costs a little under 0.21d., which

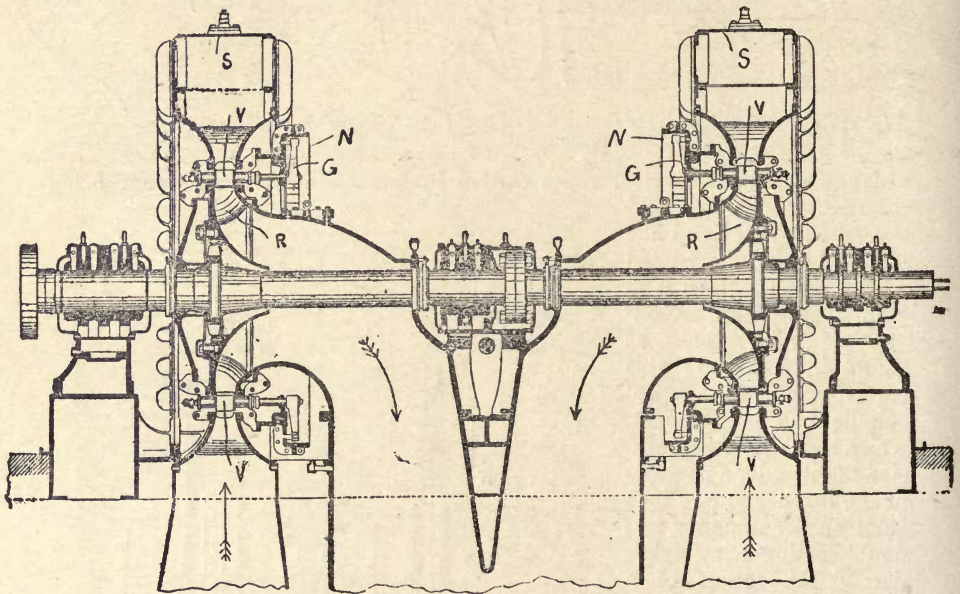

Fig. 319.—Cross-section of a 12,000 H.P. Twin Inward-flow Horizontal Turbine, for the Ontario Power Company. Pressure head of 175 feet, revolutions 187 per minute, speed control by movable guide vanes

works out at 1s. 2d. for 1,000 ton-miles, including allowance for ordinary repairs, but not for capital outlay.* Touching on this question, it would appear that the cost of installing a water-power plant is about the same as that of a steam plant—viz., from £10 to £15 per B.H.P.—and with coal at 10s. per ton the total running costs will also be not widely dissimilar for each—viz., 0.3d. to 0.4d. per unit—this estimate being based on either the maximum power output for 10 hours per day, or on a “power factor” of from 35 to 40 per cent. on continuous working, the cost per unit working out to about the same figure in either case.

Judging from the enormous hydro-electric installations already in successful operation, the costs of delivering energy in bulk must show a much more appreciative advantage over steam power for all users within a radius of at least 80 to

* These costs were estimated under conditions obtaining before the war.

150 miles of large falls, taking as an instance the Ontario Power Company, in connection with which an installation of 200,000 H.P. is in course of construction on the Canadian side of Niagara Falls; this power house to consist of three conduits, each 20 feet diameter, to convey water round other power houses to a point below the Falls, and of these one is already constructed. From the conduits the water will be taken down to 11 turbines, each of 12,000 H.P., in 22 steel pipes 9 feet diameter, the total fall, including draft tubes, being 175 feet. The turbines of this installation form an exception in point of construction to those in use in other power houses on either side of Niagara in being horizontal, of which the sectional cut * (Fig. 319) affords a very clear conception. As will be gathered, these turbines—of which there are already three in use—are of the twin radial inflow type, and are thus free from all difficulties of end balance. The diameter over the vanes of the impeller wheels *R* is 78 inches, these being bolted to conical deflecting hubs keyed on to a coupled driving shaft 14 inches diameter; the depth of the impeller vanes is deeper than that of the large single-wheel turbine shown by Fig. 311, the impellers thus conforming more closely to the mixed-flow wheel illustrated by Fig. 305. The pressure water from the downtake flumes of 9 feet diameter flows into the spiral chambers *S* at a velocity of 11 feet per second from below, the water being directed on to the impellers by swivel guide vanes *V* controlled by a series of radially-disposed arms *G*, connected to move simultaneously, and to be operated by a pressure relay governor of the kind already described. The volume flowing through each one of these twin turbines to develop 12,000 H.P. under a pressure head of 175 feet is from 700 to 720 cubic feet per second, allowing for an efficiency of 85 per cent., and the value of $\sqrt{2gh}$ at the speed of 187 revolutions per minute is 0.60, a velocity that closely agrees with Table B (see p. 405, *ante*).

The general appearance and size of these 12,000 H.P. turbines now being installed by the Ontario Power Company, who, by-the-way, are prepared to supply power in bulk at the unprecedented figure of 0.07d. per unit,† may be gathered by the photo-view (Fig. 320); which represents a twin vortex mixed-flow horizontal turbine to develop 10,500 H.P. at the reduced pressure head of 135 feet, this being the fourth and largest of an installation at Shawinigan Falls on the St. Maurice River, Quebec, supplied by the I. P. Morris Company. The available hydraulic power at the disposal of the Shawinigan Water and Power Company is 125,000 H.P., of which it is proposed to put down plant for the development of 100,000 H.P. From the plant already installed, consisting of three turbines of 6,000 H.P. each, and one of 10,500 H.P., 10,000 H.P. of electric energy is being supplied to Montreal at a distance of 84 miles over three aluminium cables at a tension of 50,000 volts (the current being stepped up from 2,200 volts), with a loss in transmission of 18 to 20 per cent., which is considered so successful that two more lines of equal capacity are under construction.

The 10,500 H.P. turbine at Shawinigan Falls differs from those belonging to the Ontario Power Company in having one vortex chamber and two discharge downtakes from the centre—one right and one left. Water pressure is supplied from a flume 450 feet long by 12 feet diameter, and enters the power house below the floor level at a head of 135 feet to an inlet in the volute casing $10\frac{1}{2}$ feet diameter, whence it is directed by 24 movable vanes on to a double impeller cast in bronze, and weighing 5 tons, which is carried by a shaft 32 feet long and measuring 22 inches diameter at its centre, this dimension tapering to 16 inches diameter on the generator side, and to 10 inches diameter on the side depicted by the engraving.

* *Inst. Mech. Engineers.*

† Estimate made in 1906.

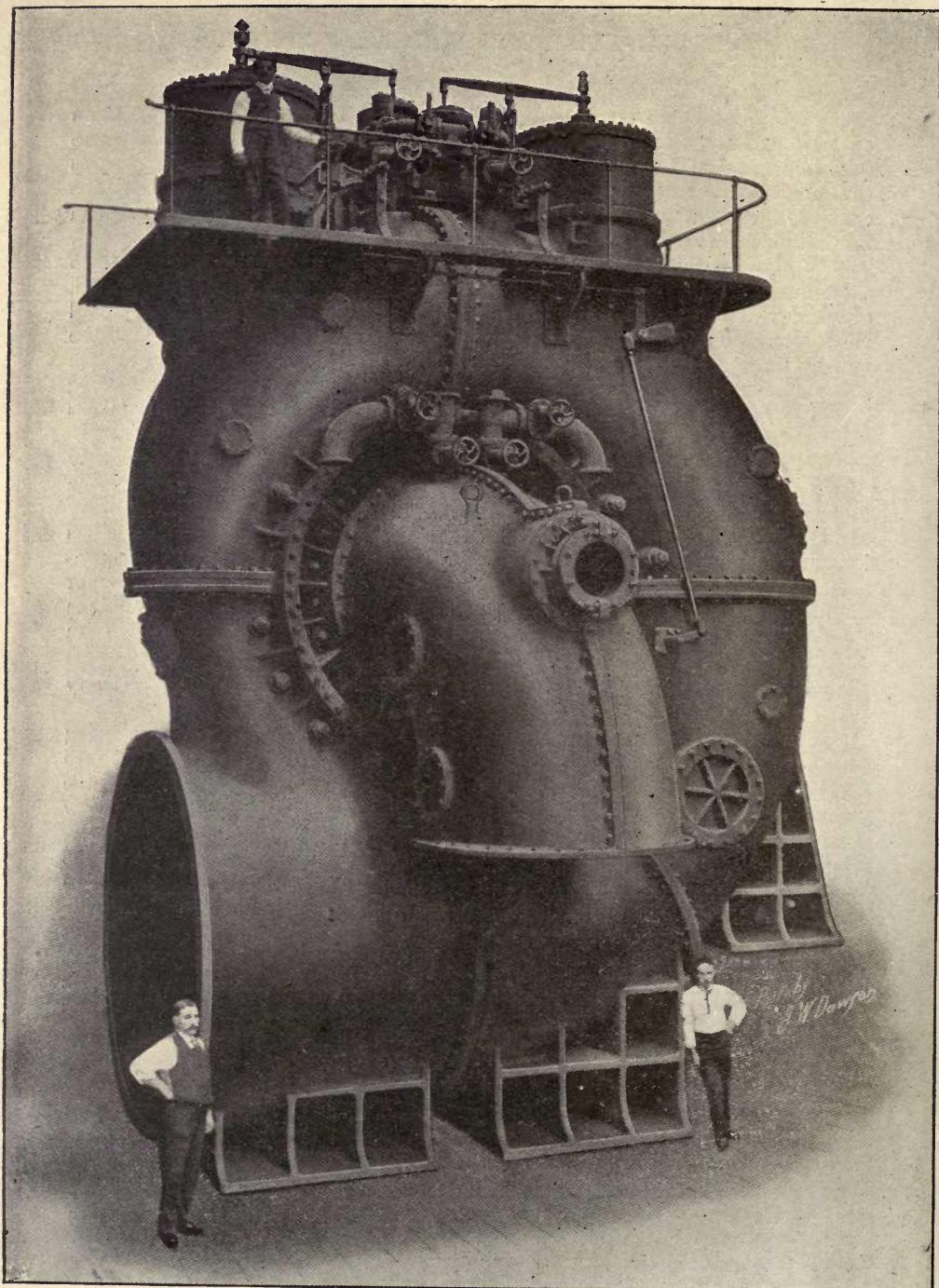

Fig. 320.—Photo-view of Double-wheel Radial-axial-inflow Horizontal Turbine. (Supplied by the I. P. Morris Company to develop 10,500 H.P. on a pressure head of 135 feet at Shawinigan Falls.)

The three 6,000 H.P. Shawinigan turbines referred to have each a central discharge draft tube S, in which is fitted a double throttle speed regulator T, controlled by a relay hydraulic engine H and fly-ball governor G (*vide* Fig. 321), and in this respect form an exception to general practice; in addition to the throttle control there is a hand-power sliding sluice ring D over each set of guide vanes, by which means each impeller R, constructed to work on the radial mixed-flow system, can be independently regulated by the gearing W.

Large power vertical turbines for deep falls, whether of the inflow or out-flow type, are usually regulated on the sliding sluice ring system with fixed guide vanes, and are balanced vertically by pressure pistons, with either single or double impellers. In illustration of modern vertical turbine construction

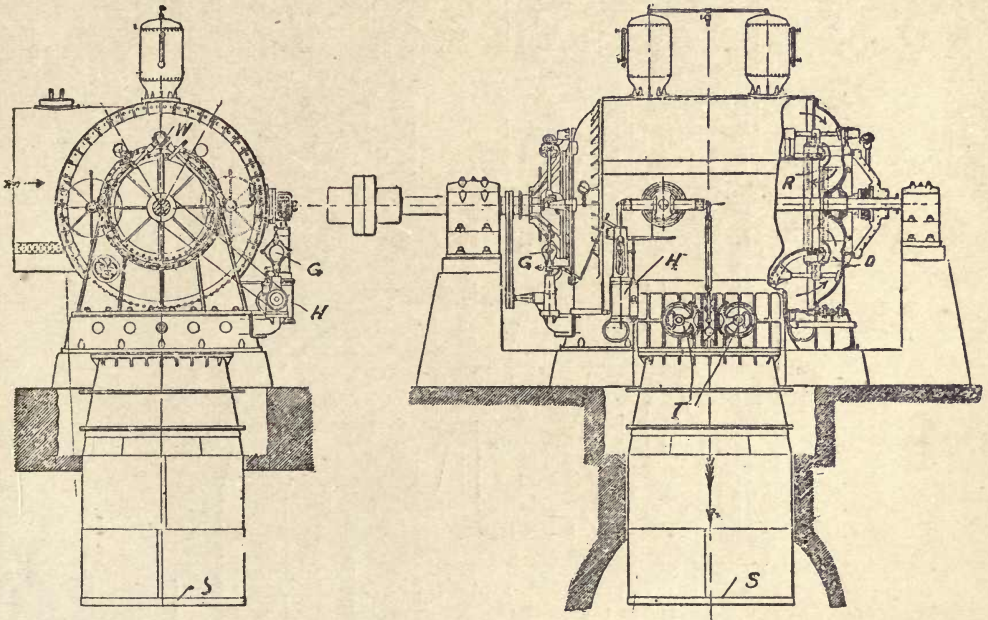

Fig. 321.—Part Sectional Elevations of One of Three Mixed-flow Central Discharge Horizontal Turbines. (Supplied by the I. P. Morris Company to develop 6,000 H.P. on a pressure head of 125 feet, and speed of 180 revolutions per minute, at Shawinigan Falls Quebec. Speed control by throttle in draft tube.)

no better example exists than the radial mixed-flow twin wheel turbines being installed for the Canadian Niagara Power Company just above the Horseshoe Falls; this power house will, when complete, have 11 units of 10,250 H.P. each, on 133 feet effective fall, the tail-race tunnel for the complete installation of 112,000 H.P. measuring 21 feet high by 19 feet wide, in which water will flow (when each turbine is running at full-gate) at 25 feet per second. The generators, of 7,500 kw. capacity each, deliver current at 11,000 volts, the weight of the turbine wheel shaft and generator field ring being approximately 120 tons, the bulk of which is carried by hydraulic pressure.

Referring to the sectional cut (Fig. 322) and general arrangement* (Fig. 323), it will be seen that two mixed-flow inward delivery impellers R, each

* *Proceedings Inst. M.E.*, 1906.

66 inches diameter, discharge into a double draft tube D of equal diameter to the impellers; water pressure from the head flume F, 100 feet in vertical length and 10 feet diameter, supplies the casing M, from which the water is directed on to the impellers by the fixed guide rings N. The two impeller rings R are bolted to conoidal-shaped hubs, which are in turn keyed to a solid shaft A, 13 to 16 inches diameter, coupled up in two lengths, the drive being continued upwards for a further 110 feet by a series of three lengths of hollow shafts, 33

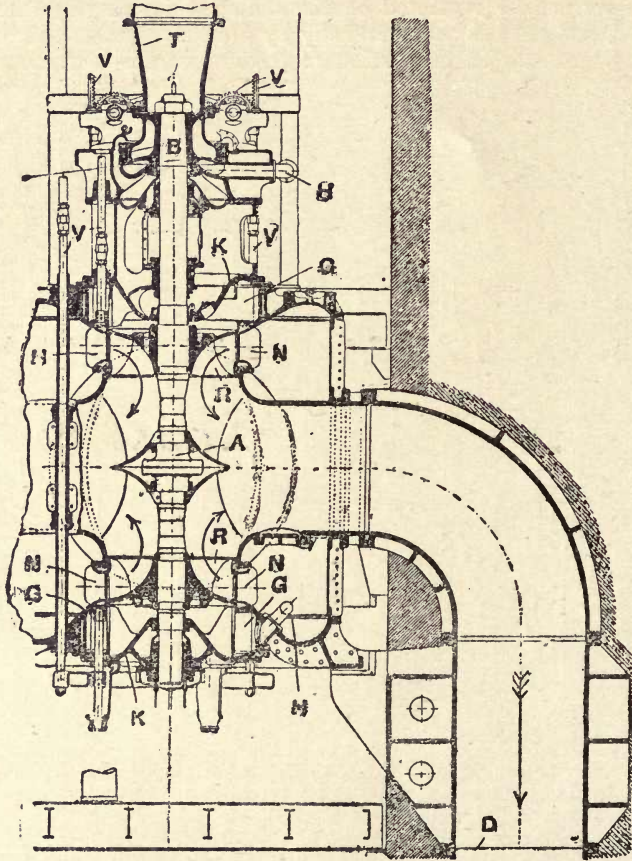

Fig. 322.—Cross-section of a 10,000 H.P. Twin Inward-flow Vertical Turbine for the Canadian Niagara Power Company. Pressure head, 133 feet; revolutions, 250 per minute; speed control by cylindrical gates.

inches diameter, with intervening solid shafts I supported by bearings, the length immediately under the generator E running in a thrust bearing U. The combined weight of the revolving parts (120 tons) is carried partly by the balancing piston B (48 inches diameter), and partly by the bottom impeller, the space at the underside of the bottom impeller being placed in communication with the pressure water in the flume F, in proportion as 36 tons by the former and 84 tons by the latter; while the space between the upper impeller and the top

end cover K is neutralised, and the pressure water under the piston B and bottom impeller is controlled by H. The governing is effected by sliding sluice rings G, connected up to a pressure oil relay governor W at the surface by the rods V, the weight of one ring balancing the other. In addition to the eleven units, each of 10,250 H.P., being installed by the Canadian Niagara Power Company—

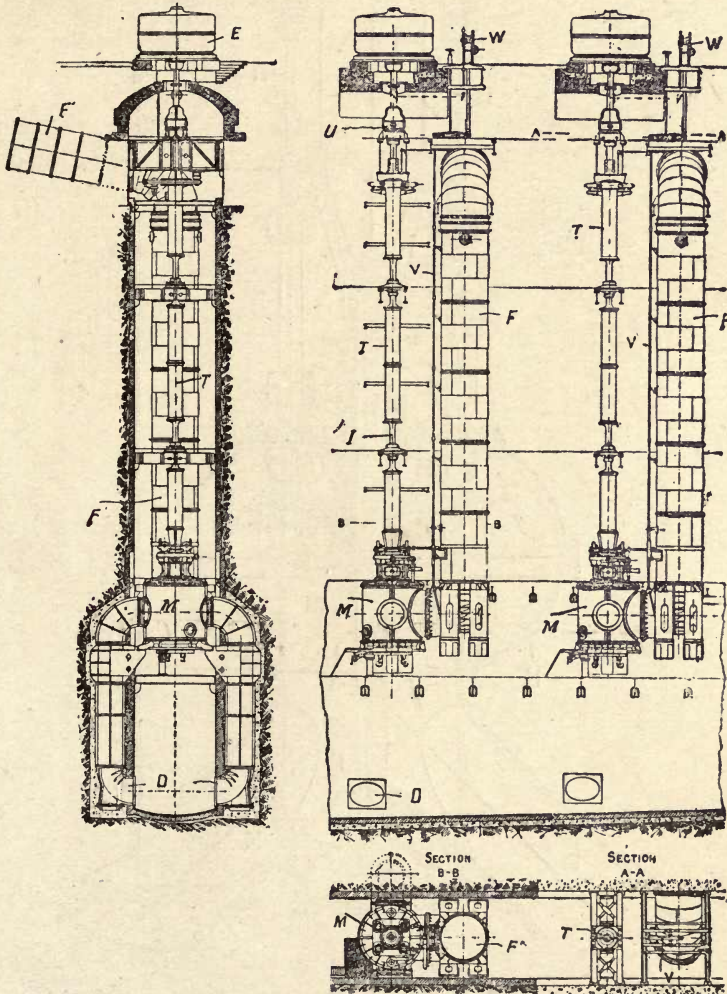

Fig. 323.—General Arrangement of Pair of 10,000 H.P. Inward-flow Vertical Turbines for the Canadian Niagara Power Company.

of which five turbines are already delivering power—the Development Company of Ontario are erecting an installation of 125,000 H.P., also on the Canadian side; this to consist of ten turbines of similar type to the foregoing, each of 12,500 H.P., coupled to generators of 8,000 kw. capacity at 12,000 volts, it being the intention to transmit part of this power raised to 60,000 volts to

Toronto over two lines carried by steel towers, 46 feet high and 400 feet apart, the total distance being 85 miles. For the accommodation of these turbines, a wheel slot, measuring 416 feet long, 27 feet wide, and 150 feet deep, has been constructed, having a tail race 26 feet by 24 feet, tunnelled for a distance of

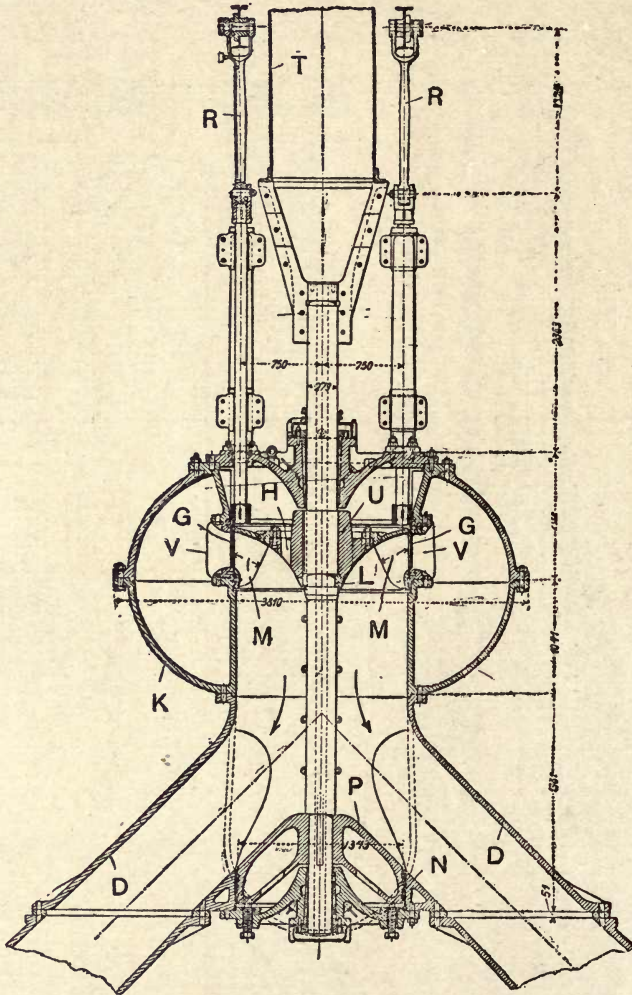

Fig. 324.—Vertical Section of "Escher-Wyss" Diagonal-flow Turbine. One of ten supplied by the I. P. Morris Company for the Niagara Falls Power Company, each capable of developing 5,500 H.P. at a speed of 250 revolutions per minute, with a pressure head of 146 feet.

1,900 feet, right under the upper rapids and discharging underneath the Horseshoe Fall.

The illustrations (Figs. 324, 325, and 326) represent a cross-section and general arrangement, together with details of the pressure relay governor, of one of an installation of ten Escher-Wyss radial mixed-flow single-wheel vertical

turbines supplied by the I. P. Morris Company for the Niagara Falls Power Company, at their No. 2 power house, each of these being designed to develop 5,500 H.P., under a pressure head of 146 feet, at a speed of 250 revolutions per minute, this representing a peripheral velocity of $0.64 \sqrt{2gh}$ of the single

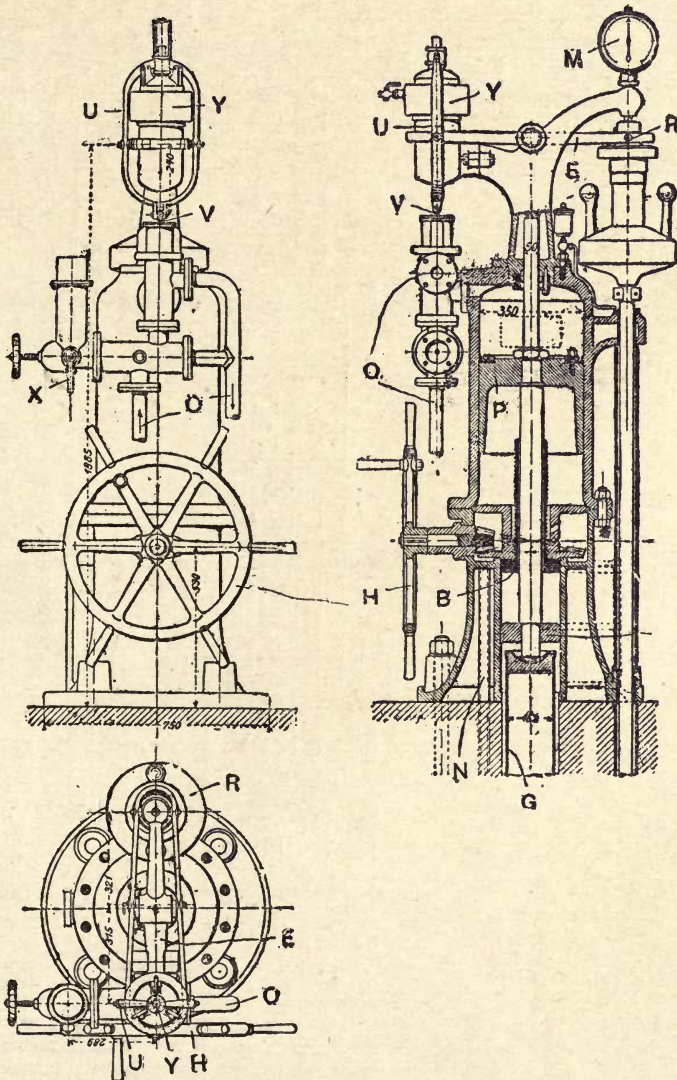

Fig. 325.—Elevation, Cross-section, and Plan of "Escher-Wyss" Oil Pressure Governor As used for the 5,500 H.P. turbines at Niagara Falls.

impeller of 57 inches diameter, which consists of a bronze casting M bolted to a steel hub U, keyed to a solid shaft 16.6 feet long by 11.2 inches diameter, and continued up a further 120 feet by three lengths of hollow shafts 3 feet

diameter. The weight of the impeller and shafting, 35 tons, and the revolving

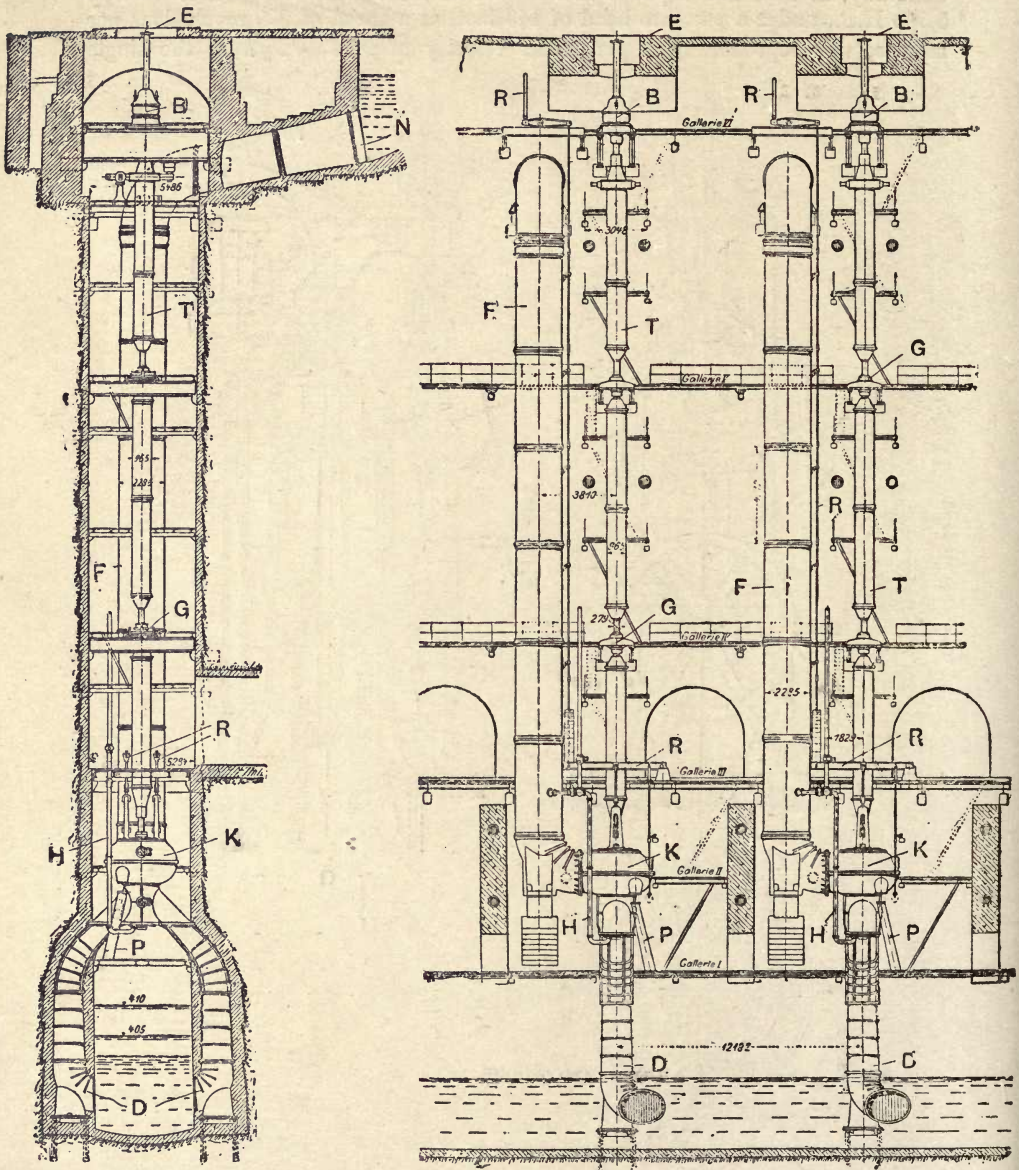

Fig. 326.—Sectional Views showing General Arrangement of "Escher-Wyss" 5,500 H.P. Diagonal-flow Single-wheel Turbines in Power House No. 2 of the Niagara Falls Power Company.

field of the dynamo, another 35 tons, is carried by an hydraulic piston P, 53.7 inches diameter, to the underside of which is supplied pressure water by the

pipe H from the flume F, this piston being grooved on its surface and running in a bronze liner N carried by the double draft tube casting D; the balance of vertical thrust is taken by ring bearings B, and the shaft at the neck between the sections T is supported by bearings G.

The pressure water which enters the flume F at N (Fig. 326) flows into the globular casing K at the side—sediment from time to time being drawn off by the drain pipe P—and is directed on to the impeller by the fixed guide ring V (Fig. 324); between this and the impeller is interposed the speed control sluice ring G, commanded by the speed rod and beam connections R, and on the generator floor E is fixed a pressure oil relay governor, as shown in detail at Fig. 325, to which the sluice-ring rod R is connected at G, and is thereby actuated in either direction by means of pressure oil at about 800 lbs. per square inch, acting on the relay piston P. The governing force is thus equal to some 40 tons, this immense power being required to ensure the opening or closing of the sluice rings in the time limited to from 3 to 5 seconds by the requirements of the generator, against the force of gravity, and against the pressure and resistance that may be set up by changes in the velocity of water flow due to inertia, recognising that a mass equivalent to 150 tons contained in the down flume F of 7.5 feet diameter, is maintained in motion by the action of the turbine at a velocity of 9 feet per second, when working at full gate, which, on being brought to rest in 6 seconds, will practically treble the pressure acting against the sluice rings for that space of time; a quicker change in the speed control naturally resulting in a more expeditious movement of the sluice ring, with a proportionate rise or fall of pressure above or below the normal of 60 lbs. per square inch.

This governor differs from usual practice in the method adopted to correct the tendency to hunt, and consists of a dashpot Y, within which is a piston that is connected by a gland-packed rod to one end of the stirrup U, the other end connecting on to a distributing piston valve V, controlling pressure oil to and from the top side of the relay piston P, the movement of V to admit or release pressure from P being controlled by the rise or fall of R, through the lever E and stirrup U. The up stroke of the relay piston is effected by the weight of the sluice ring G and rods R (*vide* Fig. 326), while the speed and extent of upward movement of P is determined by the position of the buffer B, controlled by the hand-wheel H and the stop collar L, in conjunction with the pressure regulators X, the exact speed being indicated by the tachometer M.

Outward-Flow Turbines.

In the power house No. 1 of the Niagara Falls Power Company there is installed a series of vertical outward-flow turbines of the "Fourneyron" type, consisting of 10 units, each capable of developing 5,000 H.P. under an effective fall of 136 feet, at a speed of 250 revolutions; about 30,000 H.P. of this energy is transmitted to Buffalo on three lines at a tension of 22,000 volts with an interstation loss of 10 to 12 per cent. The wheel slot for accommodating this installation, the second in point of size put down, period 1890-1895 (*vide* Figs. 327 and 328), measures 178 feet deep (the turbines running with free deviation at low water), and from 20 to 15 feet wide by 180 feet long, with a tunnel 7,000 feet long, 21 feet high, and 18 feet wide, for discharging the tail water back to the river; and in addition to this a surface canal, 1,700 feet long, 250 feet wide, and 12 feet deep, has been cut to supply the downtake flumes, the total capacity of the head and tail races thus being made adequate for the development of 100,000 H.P.

From this it will be allowed that the installation of a large power house, apart from the requisite machinery for the purpose of utilising energy from deep falls, involves considerable enterprise and engineering skill; indeed, it was principally owing to the difficulties presented by this aspect that power users were held in check for so long, the potential value of Niagara as a source of

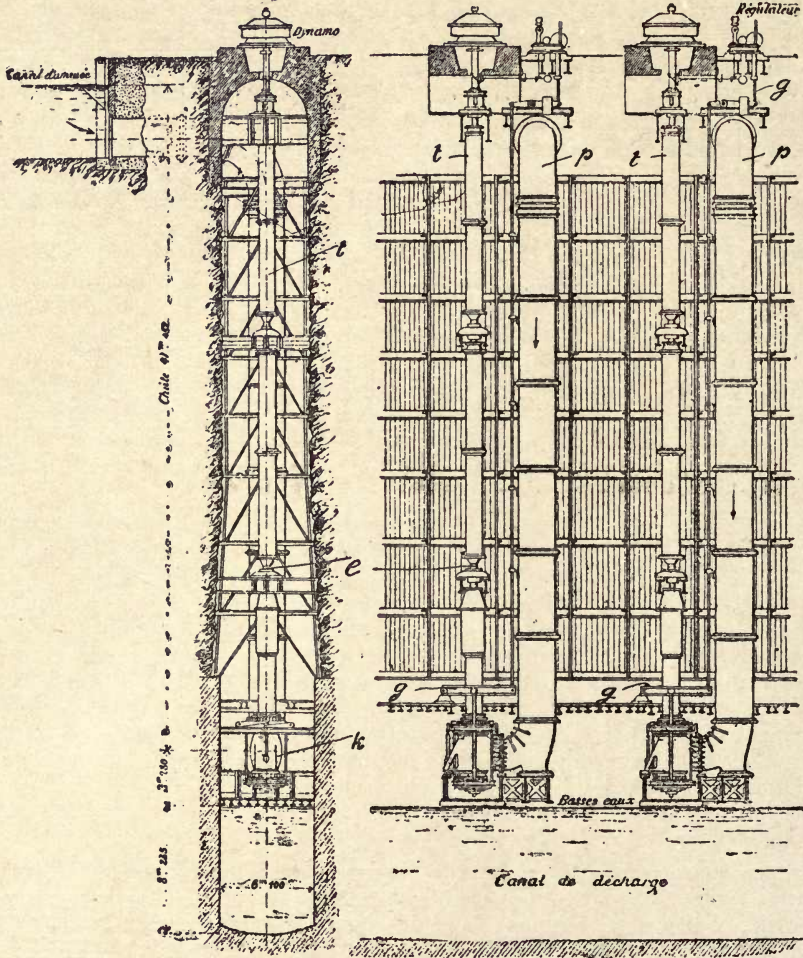

Fig. 327.—General Arrangement of Installation of Ten Piccard Outward-flow Turbines. At the No. 1 Power house of the Niagara Falls Power Company, each to develop 5,000 H.P. at 250 revolutions, under a pressure head of 136 feet.

energy having been recognised for a considerable period. The first important steps for utilising some of the four million horse-power then going to waste were taken in 1861 by the construction of a canal 4,400 feet long by 35 feet wide and 8 feet deep, the total available capacity of which, with the methods then in use—viz., 10,000 H.P.—having been fully acquired in 1885, since which date the power houses which have been established on both sides of this river, in

addition to those lower down and on the St. Maurice, have increased to a united potential capacity exceeding 600,000 H.P.

The outward-flow turbine illustrated in cross-section and detail by Fig. 328 is interesting in representing one of the largest installations of this type; the "Fourneyron" turbine having been in considerable favour 15 years ago for falls exceeding that for which the "Jonval" turbine was then considered the most suitable; both of these, now, however, have been almost entirely superseded by the more efficient radial inward-flow and mixed-flow turbines, for reasons already explained.

Referring to the illustrations, it will be seen that pressure water supplied by the penstock P, 7.5 feet diameter, enters between two fixed guide rings D, each of which is provided with three sets of vanes, which direct the pressure flow as explained in diagram III. (Fig. 297), in an outwardly tangential direction on to the inner peripheries of the two impeller wheels R, 62 inches inside diameter; these run at a velocity equal to $0.71 \sqrt{2gh}$, and at full gate will result in a

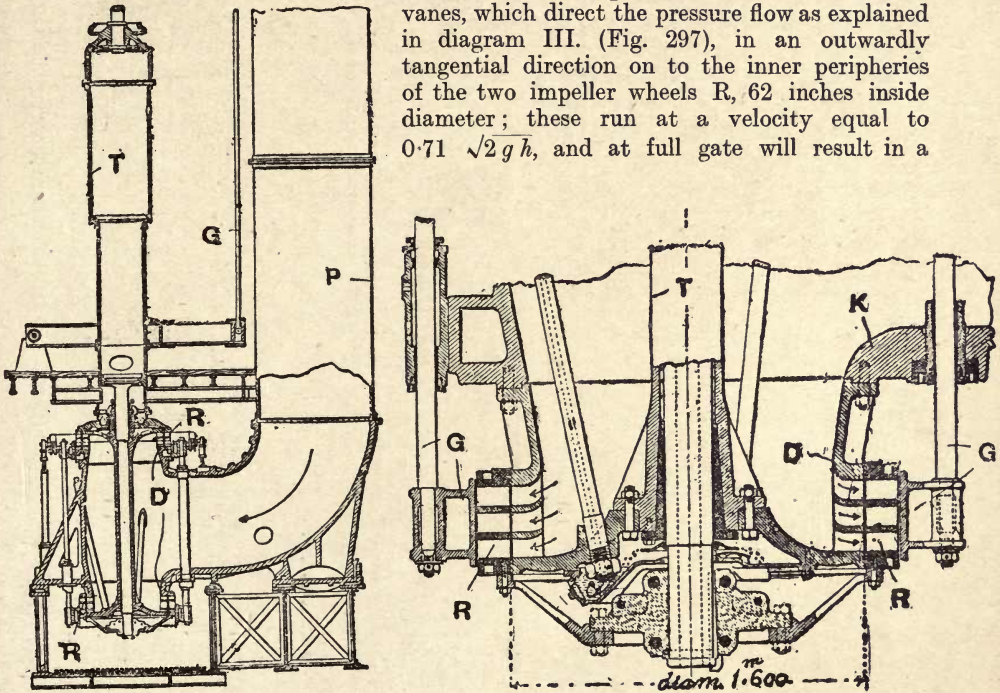

Fig. 328.—Details of Lower Impeller and Guide Ring. One of the ten 5,000 H.P. twin outward-flow vertical turbines for the Niagara Falls Power Company, showing the cylindrical sliding regulator sluice.

volume equivalent to 420 cubic feet per second, flowing down the penstock at a velocity of 10 feet per second. The number of vanes in each of the three rings of each rotor wheel R is 32; and of the stators D, 36. The weight of the two impellers, shaft, and revolving field, 68 tons, is balanced by hydraulic pressure of 60 lbs. per square inch, acting on the disc of the upper impeller, the disc of the lower impeller being open to the tail race. The drive is continued up to the dynamo floor, a distance of 154 feet, as in preceding examples—viz., by three lengths (*t*) of tubular shafts, 3 feet diameter and 1 inch thick, which are connected by solid ends (*e*), 11 inches diameter, running in bearings shown in the general arrangement.

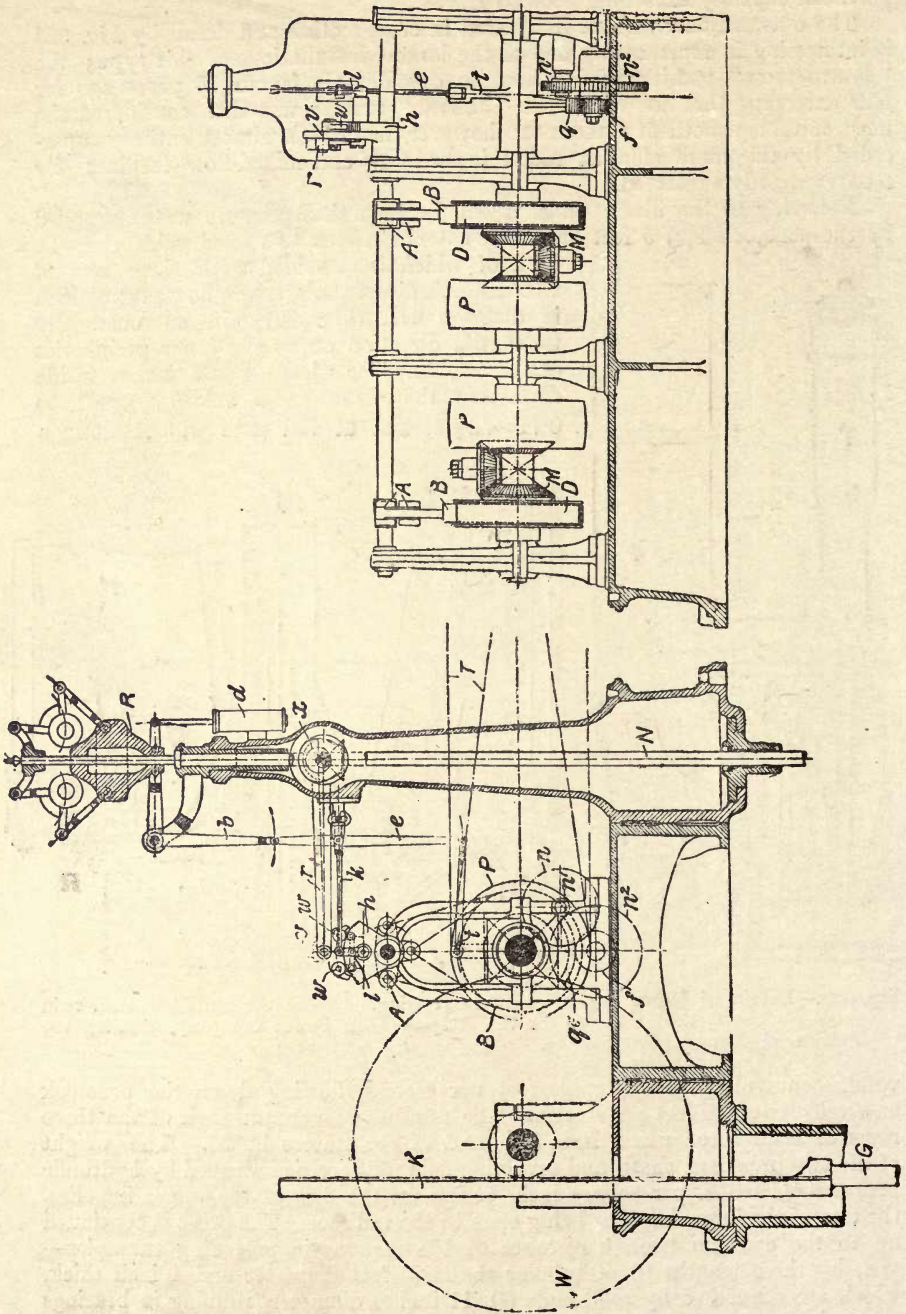

Fig 329.—Sectional Elevations of Relay Governor for the 5,500 H.P. Outward-flow Turbines at Niagara Falls.

The ten dynamos, each generating 2-phase current at 2,200 volts, were supplied by the Westinghouse Electric and Manufacturing Company, and the turbines by the I. P. Morris Company, of Philadelphia, from designs supplied by Messrs. Faesh & Piccard, now Piccard, Pictet & Co., of Geneva. An interesting feature in these turbines is the powerful mechanical relay governor shown in elevation and cross-section by Fig. 329, consisting of a high-speed fly-ball governor R, driven by the shaft N from the turbine shaft; the rise or fall of R, through levers (*b*) and (*e*) and rod (*k*), puts one or other of the pawls (*w*) into engagement with the ratchet quadrant (*h*), by which means the oscillatory motion communicated to the quadrant (*v*), through rod (*r*), from the eccentric (*x*), driven by a pair mitre wheels from N, is utilised to throw over (*h*) to right or left, according as one or other of the pawls (*w*) is put into gear with (*h*) by the rise or fall of R through (*b*, *e*, *k*, *l*). The effect of this movement is to tighten one or other of the brake straps B round the drums D, thereby partially or completely arresting their rotation. The two belt-driven pulleys P revolve freely on the shaft so long as the drums D are free to rotate; but on either of these being held fast, one of the trains of mitres M will be partially or totally locked; and whereas the middle mitres are carried by arms keyed fast to the relay shaft, any differential motion of either drum D to either corresponding driving pulley will be transmitted to the relay shaft, thus driving it in the forward direction or the reverse, the pulleys P being driven in opposite directions; and by this means the sluice rings G, commanding the outflow waterway through the two impellers R, are moved towards or away from the centre of the turbine casing K (Fig. 328) in the manner shown on the governor drawing—*e.g.*, by the spur and rack drive W K. The action of the governor is steadied by a dash-pot (*d*), and the period of movement of G in either direction determined by the train of wheels (*n*¹), (*n*²), and (*f*), in oscillating the sector (*q*), and with it the lever (*t*) connected to the bottom end of the governor lever (*e*), by which means the lateral movement imparted to one end of (*e*) is overtaken by an opposite movement from (*t*) after a certain interval, thus neutralising the tendency for the relay motion to be continued for too long a period.

An exception to the generally recognised practice of discharging direct from the impeller of an outward-flow reaction turbine direct into the tail race has been adopted by the I. P. Morris Company in an installation of four "Fourneyron" turbines for the Utica Gas and Electric Company, at Trenton Falls, New York State. The sectional views (Fig. 330) show one of these, and represent one of the most modern examples of this type, constructed to discharge centrifugally into a casing provided with a draft tube D, 20 feet long, by which means the total pressure head is increased from 246 to 266 feet. These turbines are outward flow, single-wheel inverted, receiving pressure water from a flume F, 6 feet diameter, from which it is diverted radially in a tangential direction on to the impeller R, connected up direct with the revolving field of the generator E, the weight of which is carried by a pressure oil thrust bearing. The speed control as in the preceding example is effected by a cylindrical sluice ring T, commanded by a Porter governor G and relay hydraulic engine H supplied with pressure water from the flume F, the control being also under the command of a hand gear A; and to compensate for the long length (2,300 feet) of supply flume, relief valves are provided at V to guard against the effects of concussion.

The "Girard" turbine differs from the "Fourneyron," in that instead of pressure water being continued all round the inner periphery of the impeller, as in Figs. 328 and 330, and shown diagrammatically in Fig. 297, the pressure water is directed by guide vanes or nozzles on to a portion of the wheel limited

to one-fourth or less of its circumference, for the purpose of obtaining a high peripheral velocity with a comparatively slow rotation; this class of turbine combines an impulse effect with that of reaction, and in the form generally adopted a centrifugal effect also, in which respect it resembles the "Fourneyron." The action and theoretical construction of the "Girard" turbine is clearly represented in diagram IV. (Fig. 298), and will not require any further explanation other than to repeat that pressure water is directed on to a part of the inner circumference of an impeller ring N by guide vanes or nozzles P,

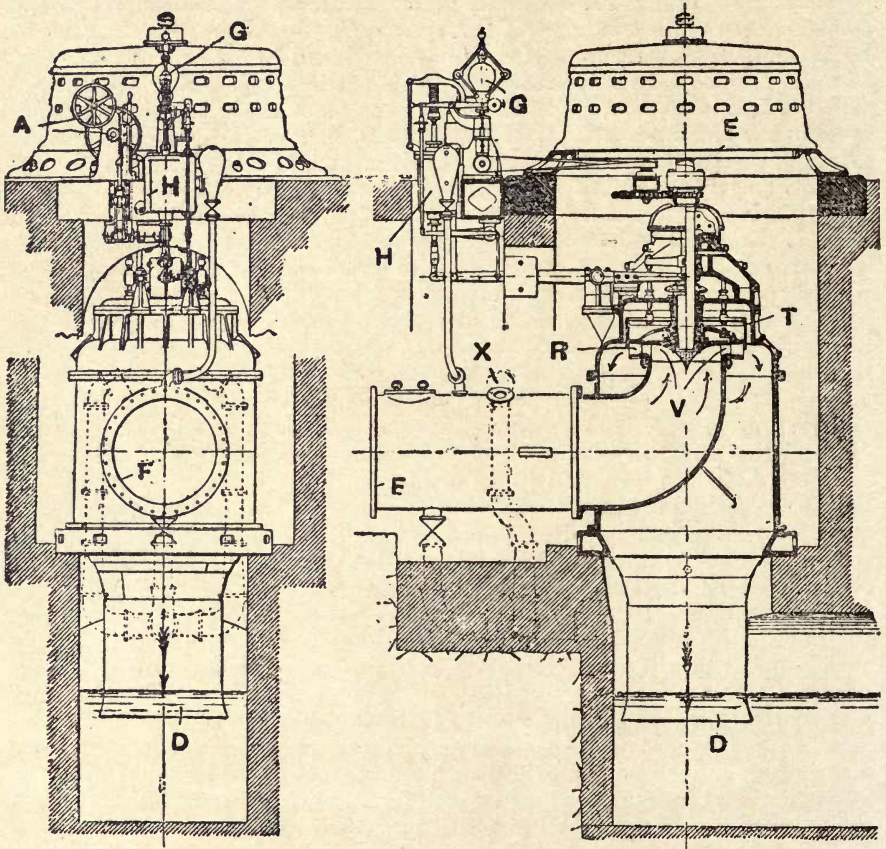

Fig. 330.—2,000 H.P. Single-wheel Outward-flow Vertical Turbine at Trenton Falls, N.Y. Pressure head, 266 feet; revolutions, 360 per minute. Speed control by cylindrical sluice gate.

arranged at such an angle in relation to pressure and rim velocities that the latter shall be about 45 per cent. of the former (*vide* Table B, see p. 405, *ante*), the impeller is usually covered by a splash guard D, and always arranged at a sufficiently high level to discharge quite clear of the tail race.

Although in the diagrammatic illustration (Fig. 298) a turbine of this class is shown proportioned for a pressure head of 100 feet only, it must not be assumed that this marks the limit of pressure for which it is suitable, but rather the

minimum than the maximum, great numbers having been put down for falls ranging from 50 feet upwards to 2,000 feet; and in sizes varying from the

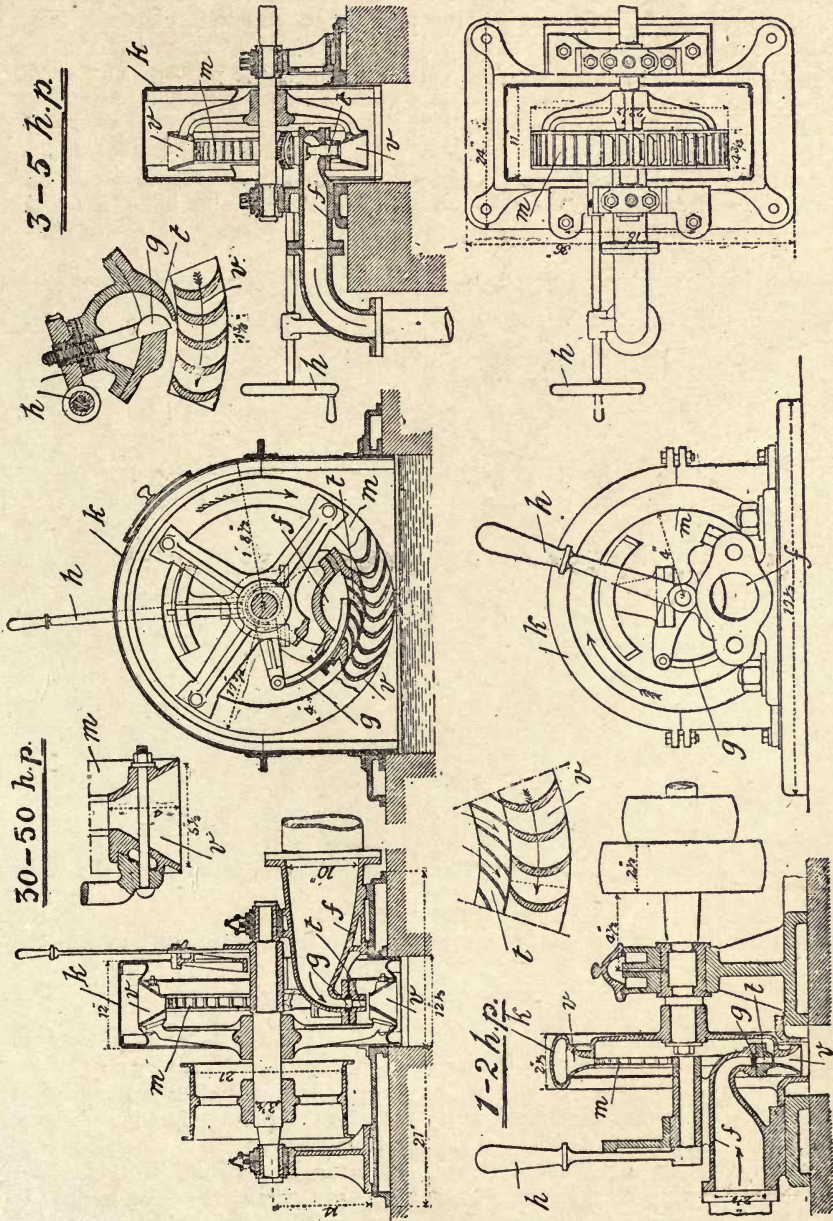

Fig. 331.—Sectional Illustrations of "Bell-Girard" Turbines. Suitable for powers from 1 to 50 H.P., and pressure heads from 100 to 300 feet, showing methods used for speed control.

diminutive 1 to 2 H.P., shown together with a 3 to 5 H.P., and 30 to 50 H.P. (vide Fig. 331), to a goliath turbine of 2,200 H.P., having an impeller 16.7 feet.

diameter, and weighing nearly 8 tons, thus forming a powerful flywheel, which constitutes one of the features of this type of turbine.

The general construction and method of speed control will be readily gathered from the three small Theodore Bell turbines already referred to, these being each horizontal, with outflow annular wheels having guide vanes on the underside only, controlled by a sliding sluice which regulates the pressure flow either by cutting out or reducing the area of the waterways. In the illustrations the several parts of each size are lettered to correspond, (*f*) denoting the pressure supply pipe or flume (*t*), the guide vanes or nozzles controlled by the sliding sluice valves (*g*) and actuating gear (*h*); the jets in number varying from one to four, are projected on to vanes (*v*) carried by the annular impeller wheels (*m*), and shaped according to pressure, as explained by diagram IV (Fig. 298),

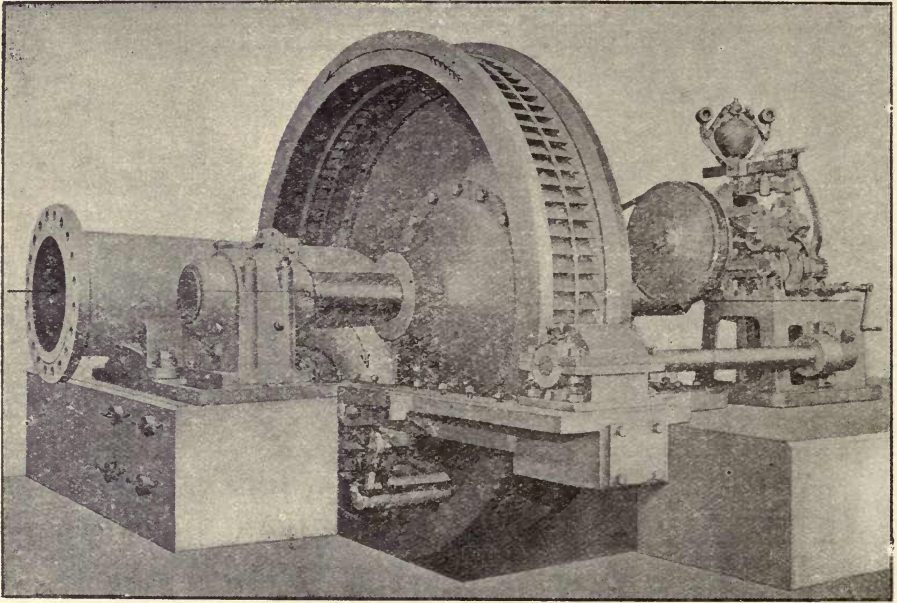

Fig. 332.—Piccard Double Jet Outflow Turbine. To develop 1,580 H.P. at 500 revolutions and fall of 1,340 feet, showing ratchet relay governor and impeller with hood removed.

from which the water is discharged downwards, the wheel being covered by a hinged hood *K* to prevent splash.

From this description it will be seen that the "Girard" turbine resembles more closely the "Fourneyron" than any other—*e.g.*, both work by an outflow or centrifugal action—the former is, however, adapted for higher pressures than the latter, and has been extensively used for comparatively small powers, where falls of from 150 to 400 feet or so are available.

Probably the most advanced development of the "Girard" turbine has been achieved by Messrs. Piccard, Pictet & Co., of Geneva, the designers of the 5,000 H.P. "Fourneyron" turbines, illustrated by Fig. 328, who have supplied several large horizontal turbines of this type, of which the photo-view (Fig. 332) is a representative example; this particular size illustrates one of three 1,580 H.P. turbines supplied in 1901 to the Noalesa Hydro-Electric Works,

Mont Cenis, to work at 500 revolutions under a fall of 1,340 feet; the value thus of $\sqrt{2gh}$ in these as in other large wheels referred to works out at 0.54 to 0.55, and compares very well with the figures given in Table B (p. 405, *ante*); the flywheel impeller of 7.5 feet outside diameter is shown with the hood removed. In these, as in other turbines of this type and make, the pressure flow is directed on to the inner periphery of the wheel to vanes opening out in width and curved backwards (as projected on the diagram) from two guide passages regulated in waterway area by a sluice operated by a ratchet action relay governor of the kind illustrated by Fig. 329, which is capable of controlling the turbine to the requirements of electric generators, independently of a pressure cylinder.

Jet-Action Turbines.

Jet-action or tangential-flow turbines, variously known as spoon or "Pelton" wheels, are adapted for high pressures only—the higher the pressure the greater

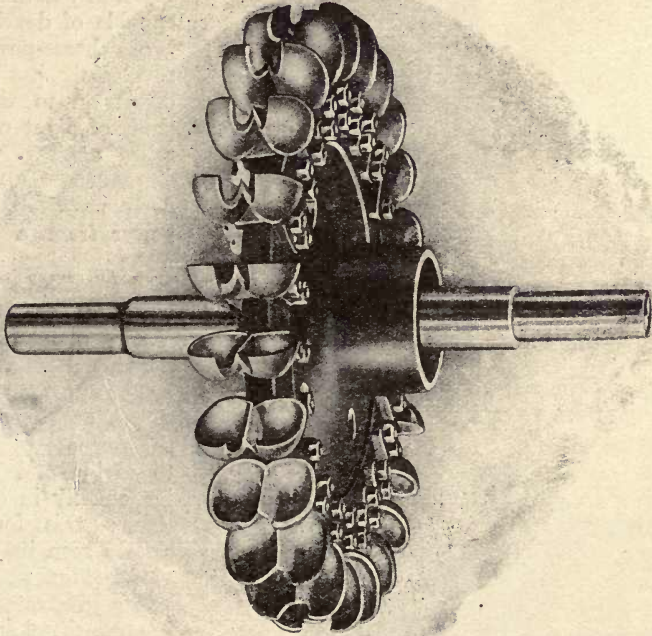

Fig. 333.—Victoria Impulse or Jet-action Turbine Wheel.

the advantage of this type of turbine over others, owing to its simplicity and to the effectual manner in which it is capable of converting the kinetic energy of high-velocity jets into mechanical power—but as the action of this simple form of turbine has been fully explained, with the help of diagram (V), Fig. 297, and Tables A and B, which show the best form of construction, and the relative velocities of jet and rim to obtain the most efficient effect, it will not

be necessary to again describe the principles and theory of its working, it being sufficient to state that the impeller can in no case exceed the velocity of the jet

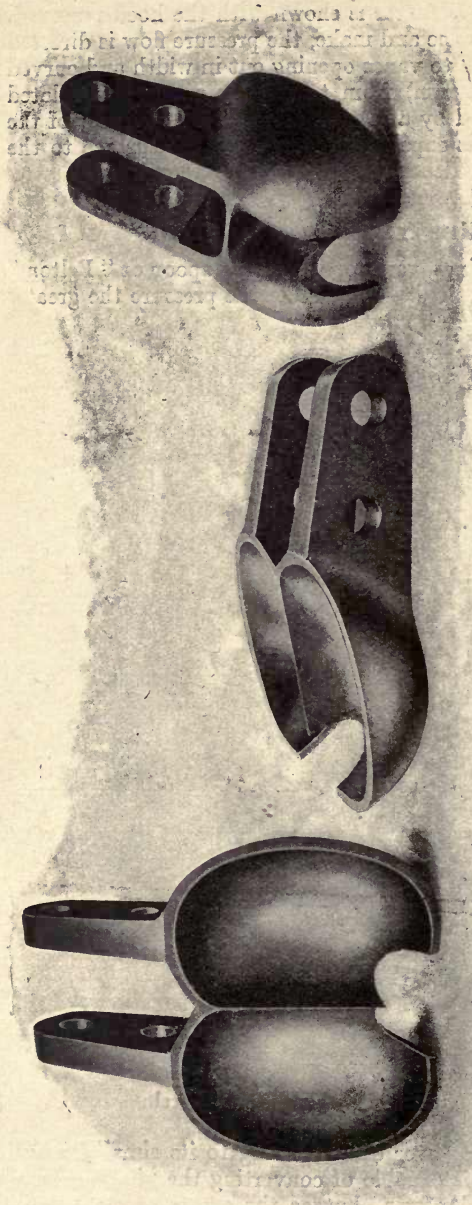

Fig. 334.—Detailed Construction of Buckets used in the Victoria Impulse Wheels.

projected from the nozzle, and while the greatest power can be obtained with differential velocities of rim and jet of from 220 to 200 per cent., the greatest torque is produced with the wheel at rest; in consequence of this property, turbines of this type are adapted for a very variable torque, and have been applied to such purposes as rolling mills—*e.g.*, a "Gilkes" jet-action wheel 21 feet diameter, and capable of developing 200 brake horse-power at 36 revolutions, has been fitted direct on to the driving shaft of a set of tin-plate rolls at a works in Cwmavon, where the wheel derives the necessary power from a fall of 98 feet.

In order to obtain the best effect the buckets are formed with a ridge dividing each double hemispherical or cup-shaped vane, as shown at E in Fig. 297, the purpose of this being to divide and deflect the jet equally in both directions; this formation is clearly seen in the photoviews (Figs. 333 and 334), which illustrate a Victoria impulse wheel and detailed construction of the buckets, which are cast in manganese-bronze on chills by a special process, in order to ensure a hard and smooth inner surface; the buckets, which are bolted on to a steel disc, are as

shown longer in proportion to width on the larger wheels, than on the wheels of smaller diameter. In the earliest turbines of this type the vanes were

quite flat—but as the effect of a flat surface on the jet is to pulverise the water without any useful reactionary effect, thus resulting in only one-half the force being transmitted as would be capable if the total energy of the jet could be absorbed by a reaction form of vane—various forms of buckets have been introduced from time to time to increase the efficiency of tangential or jet wheels; some with edges turned up at the sides only, and not on the outside, some with cup-shaped buckets, others with spoon-shaped buckets, and so on; even now, opinion differs as to the correct form to adopt—*e.g.*, in the “Gilkes” turbine the buckets are rectangular in shape and set back on the wheel at an angle of about 30° ; in the “Escher-Wyss” turbine the buckets are less rectangular and present a surface inclined back some 10° to 20° , these being of greater depth than width; in the “Bell” turbine the buckets are also rectangular and slightly set back, but are nearly twice as wide as deep; however, all agree on one point—*i.e.*, in the use of a dividing centrally-placed ridge, this being ascertained to have a decided effect for the good in the all-round efficiency of the wheel—an efficiency that does not fall short of the radial mixed-flow turbine for falls from 150 to 300 feet, and which is unapproachable by any other type for falls exceeding from 400 to 500 feet and upwards, unless exception be allowed for the economical working of turbines of the improved “Girard” type.

The next feature in degree of importance in the working of a tangential wheel is the form of the nozzle, this being influenced more by the method of governing than by any other cause—*e.g.*, referring to Fig. 335, here we have a double-wheel impulse turbine capable of developing 250 H.P. per wheel under a pressure fall of 260 feet, in which the cross-sectional shape of the nozzle is subordinated to the requirements of the governing method used; in this instance the nozzles T are rectangular, and adjustable in area by means of hinged lids F, controlled by the relay pistons H, in turn controlled by the fly-ball governor R, lever mechanism and distributing valve for each cylinder; in this manner pressure water controlled by the regulator L at the full pressure head is admitted over the pistons H, thus depressing P and increasing the area of the nozzles T; and *vice versa*, as the result following an increase of speed, water will be exhausted from the top of the relay pistons H by the action of R, when H will be forced up by the static pressure in the nozzles, which, although not equal to the full pressure at the base of the flume, is at all times sufficient to lift H against head resistance and close the apertures T with sufficient celerity for quick control.

In connection with high-pressure turbines, the pipe line is more often than not of considerable length, and may exceed 1,000 feet or more without a break. Now with a velocity of flow of 10 feet per second the momentum effect in a flume of 1 square foot in area, and of such a length as this, would be 19,000 foot-lbs.—*i.e.*, 133 lbs. per square inch—which, in addition to the pressure resulting from a fall of 300 feet, for example, would raise the pressure at the turbine nozzle from 130 to 263 lbs. per square inch, provided that the velocity be reduced from the full velocity of 10 feet per second to zero in 1 second of time; and it follows that on the water flow being reduced by throttling at the turbine from 10 feet to a velocity of 5 feet per second—*i.e.*, half-power—the increment of pressure at the nozzle will be 66 lbs. per square inch, with the result that, in order to reduce the turbine to run at the same speed on half-load, the nozzle area in place of being reduced 50 per cent. would necessitate a reduction of 75 per cent., in order to avoid a momentary acceleration; and naturally, with a pipe line in which the water column is proportionately greater to the pressure fall than

this, so will the momentum effect or hydraulic concussion increase until a condition of reaction be realised such as would tend to make it unsafe to run with

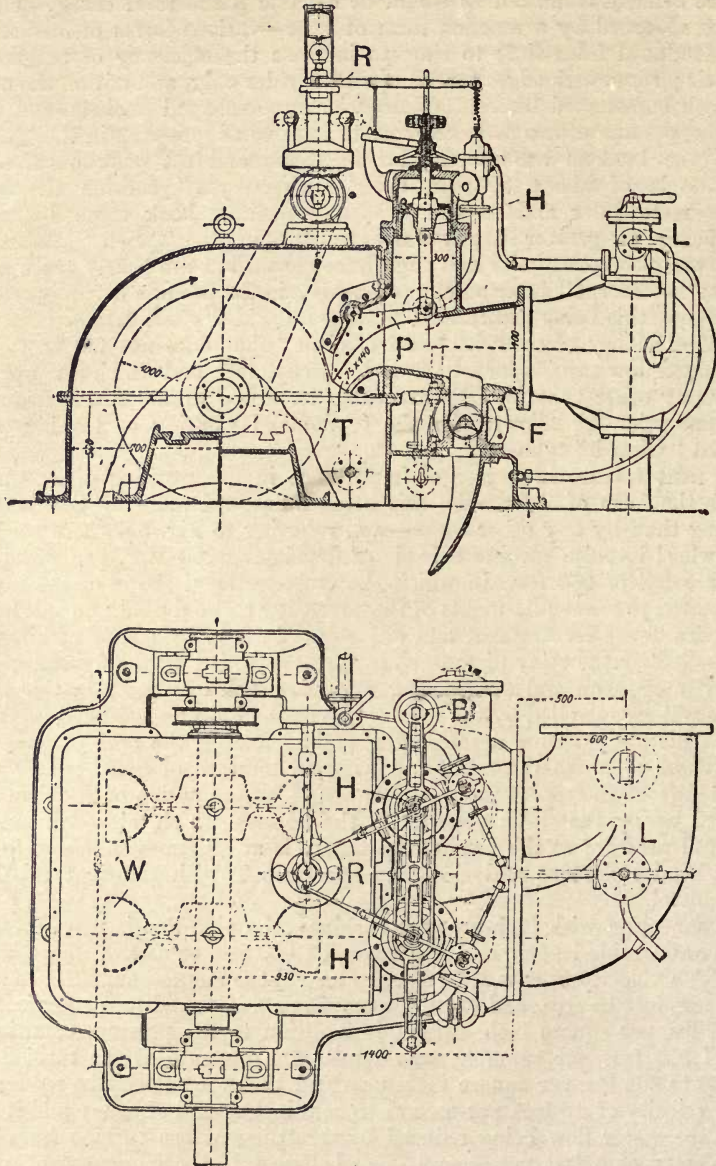

Fig. 335.—Double Wheel Impulse Turbine. Supplied by Escher-Wyss & Co., to develop 500 H.P. on a pressure head of 260 feet at St. Gall, Switzerland.

such quick changes in load factor as are frequently demanded in the driving of electric generators.

Now, a simple and effectual means presents itself to obviate increase of pressure due to the diminished flow,* and one that is generally adopted for long lengths of pipe line—to wit, that of providing for a corresponding opening at the base of the flume to the reduced gate for the time being, the by-pass slowly closing by an action independent of the governor. In the example now being considered, a temporary escape is afforded by the valve F, which is opened to a corresponding degree to that in which the nozzle T is closed by the action of the pressure piston H, but is again closed by a spring and cataract motion contained in B after an interval depending on the length of water column.

A similar effect to this may be produced in another way—e.g., as shown in the diagrammatic section (Fig. 336). In this example the same principle is adhered to, and may be described as follows:—On the closing of the waterway area past the nozzle (n) by the movement from right to left of the plug (p), by the action of the relay lever connection (y), the escape valve (e) is simultaneously

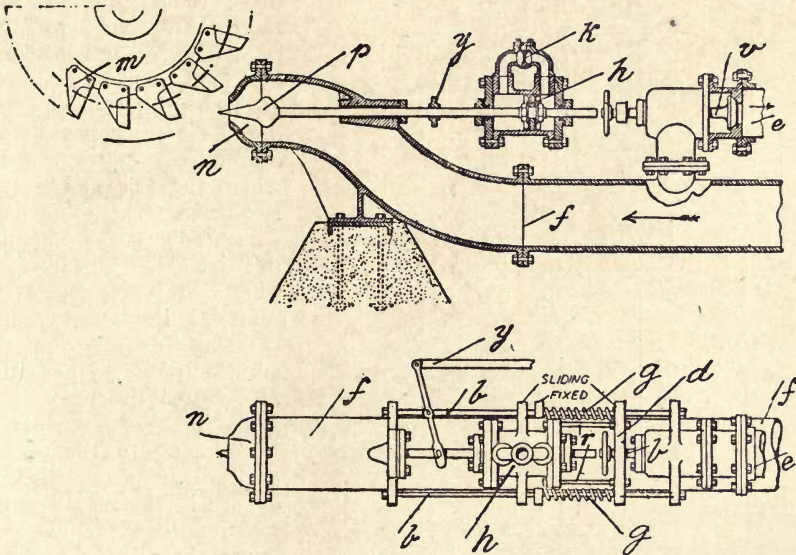

Fig. 336.—Arrangement of Compensating Pressure Control for Impulse Turbine.

opened to a proportionate degree; this effect is brought about by reason of the sliding cataract cylinder (h) being traversed from right to left along the bars (b) by the action of its piston, and in so doing carries with it the crosshead (d) through the connecting-rods (r), thereby opening (v) and allowing water to escape from the flume (f) to the tail race by the pipe (e). Now, as this movement is effected against the pressure of the two springs (g), the cylinder (h), and with it the valve (e) will be slowly moved from left to right by the force of (g), the time being determined by the opening of the cataract valve (k), the escape of pressure water past (v) is thereby limited to a space of a few seconds only. This method, although compensating for suddenly-applied diminished flow at the nozzle, does not prevent a certain fall of pressure in the flume as the result of an increased flow against the impeller. This, however, is not of material significance, as the opening is controlled by the cataract, and thereby prevented from being suddenly applied as may be the case in closing, as the throttling movement is simply opposed by the action of the springs, and can

* This in practice is rarely allowed to exceed the static pressure by more than 20-30 per cent.

be performed quite independently of (*h*) by the action of the relay governor rod (*y*).

A very simple form of telemotor governor is illustrated by Fig. 337, in which (known as the Pitman) an ordinary belt-driven governor *G* controls through lever *L* and rod *H*, a small piston slide valve *E*, and by this means the pressure flow from the service flume to either side of the motor piston *P* through either one of the ports *D C*, thus causing it to be traversed to the extent required in one direction or the other, and to carry with it the regulator used to shut off

or turn on the pressure flow to the turbine, by means of a suitable connection to the crosshead.

To meet the demand of electrical engineers for a drive that shall not vary more than from 2 to 3 per cent. between full load and no load, relay hydraulic governors have been introduced for either pressure-oil or for pressure-water drive where the fall exceeds 100 feet or so. The action of a Gilkes governor as applied to a jet action turbine (*vide* Fig. 338) is essentially the same as in the preceding example, except for the addition of a compensating motion for the purpose of bringing the distributing valve back to the central position after the slightest change in the regulator has taken place; for, as well known by all engineers experienced in the working of turbines, the action of water is comparatively sluggish as compared with steam, and in consequence of this the fluctuation of the governor is exaggerated and delayed

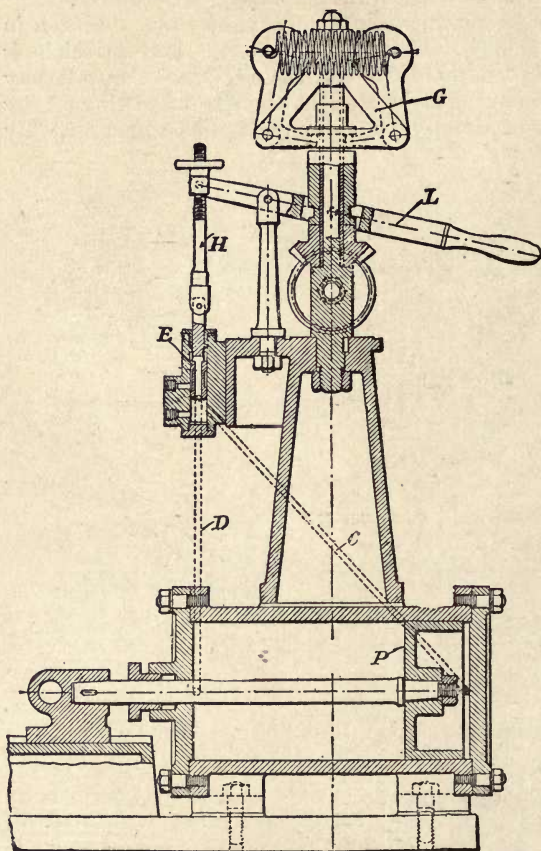

Fig. 337.—Pitman Hydraulic Turbine Governor.

beyond the requirements of the turbine, with the result that a rhythmic action is set up, known as hunting, and to correct this tendency the control of the distributing fluid to and from the hydraulic relay is divided between the governor and the movement communicated to the sluice gate controlling the flow of pressure water to the turbine. Pressure-relay governors of different makes in which the construction has been variously modified to anticipate this tendency to hunt have already been described, and in this connection may also be mentioned the special mechanism which has been adopted in the "Piccard" mechanical relay governor, illustrated at Fig. 329, for overcoming this same difficulty.

In the Gilkes pressure relay governor, as illustrated by Fig. 338, water is supplied from the pressure flume to a filter A, whence it enters *via* B to the distributing valve V, and flows thence through pipes S to either end of the relay cylinder D, under the control of the governor R through lever connections L K, and under the steadying action of the dashpot T. In order to prevent an exaggerated movement of the plug N over and above the requirements of the turbine wheel W, one end of the governor lever L is connected to a plunger J receiving a vertical movement through E from the relay piston-rod, the stroke of which can be limited in either direction by the crosshead P and the lock nuts shown; and where extreme regularity in running is essential an isochronous gear is also added consisting of weighted compensating levers F and rod

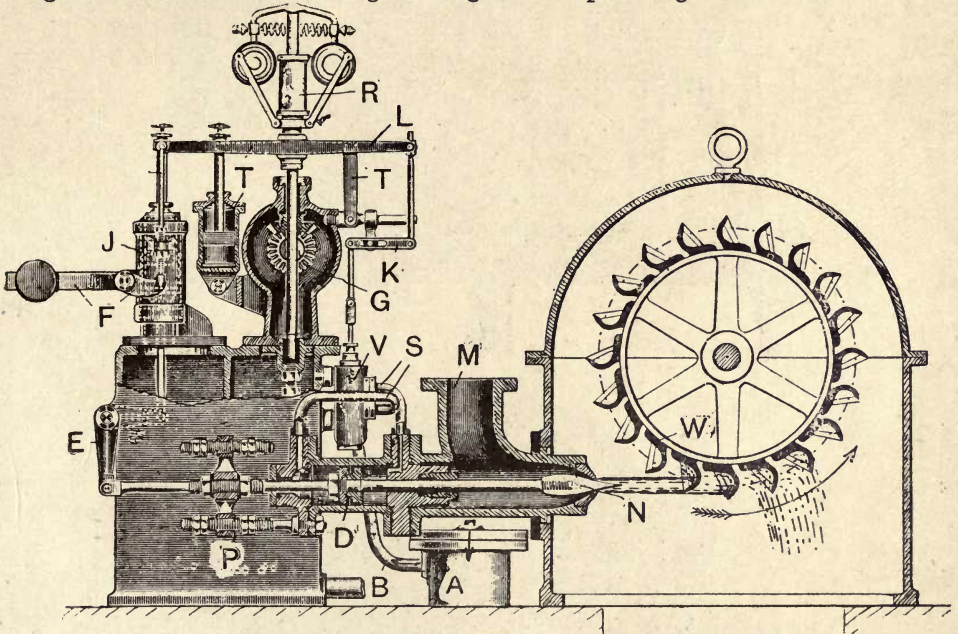

Fig. 338.—Sectional Elevation of "Gilbert Gilkes" Hydraulic Compensating Governor for Jet Action High-pressure Turbines.

connecting these with the pendulum lever T for the purpose of taking up all slack in the joints.

The output per unit of weight from impulse turbines of the class in which a single tangentially-applied jet is used is less than the power that can be derived from efficient reaction turbines; this is obvious on a moment's consideration, for in the former the conversion of energy is confined to a very small portion of the rim of the wheel, while in the latter the entire surface is active. This disadvantage of the impulse wheel in power duty per unit of weight can be lessened by employing two or more jets to strike the buckets at different points on the circumference, but is not often adopted, excepting in vertically arranged turbines, as it interferes with the freedom of deviation in which the wheel should revolve.

The method now in universal use for controlling the area of the driving jet in connection with tangential or impulse wheels of the class now being

considered, is on the central displacement principle, in the application of which a circular cone-shaped nozzle, provided as shown with a long taper plug or spear under control endways of a regulator, is used, which for large powers is usually directly connected to the piston-rod of a hydraulic governor. When the nozzle is properly proportioned the jet issues as a clear and transparent rod more or less hollow in section close up to the nozzle, according to the throttle displacement of the central plug; the jet, however, converges to a solid cylinder of water a short distance from the nozzle, even when the supply is considerably reduced in volume. The rigidity of the jet, which, of course, depends on its velocity,

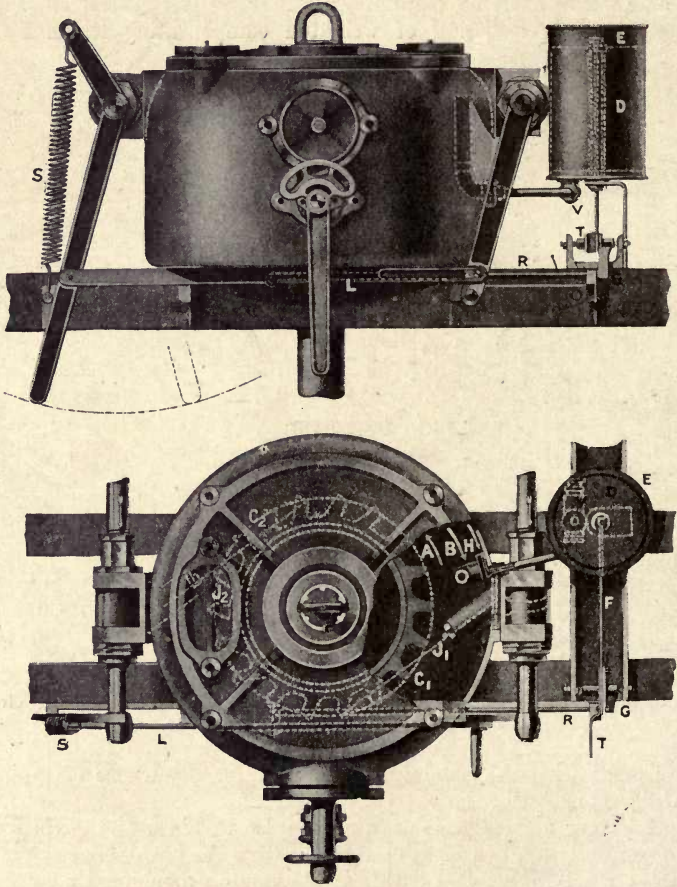

Fig. 330.—“ Watson-Laidlaw ” Impulse Motor for “ Weston ” Centrifugal Machines.

is considerable, and may under high-pressure heads be more comparable to a solid bar of glass than to a liquid.

Before passing on to describe the various controlling methods and types of governors used in connection with impulse and reaction turbines for the smaller powers may be mentioned a form of turbine used for actuating water-driven Weston centrifugals, as supplied for dehydrating sugar, in which a rather remarkable application of the impulse principle with a double jet is used. In this instance a separate jet wheel is arranged vertically over and directly coupled

to the vertical spindle of each centrifugal, and is arranged with two nozzles, one being used to direct a jet which is used only for the purpose of accelerating the wheel, and the other to maintain the centrifugal in motion after the required speed has been attained. The water motor (*vide* Fig. 339) is supported on a frame over the centrifugal, and consists of an enclosed spoon wheel driven by jets at about 100 lbs. pressure from the two nozzles J^1 and J^2 , the latter being only used to accelerate the wheel, and is then cut out of action by the spring-actuated trigger gear S L R. This release action is controlled by the float D contained in the cistern E, through the lever F and detent G, and is brought into effect on the wheel attaining the required speed by reason of spent water from the jets C^1 and C^2 on leaving the wheel being caused to swirl round the casing, as shown at B, when a portion of it will enter the scoop H and thus pass into the cistern E with the effect described. The rate of acceleration can be

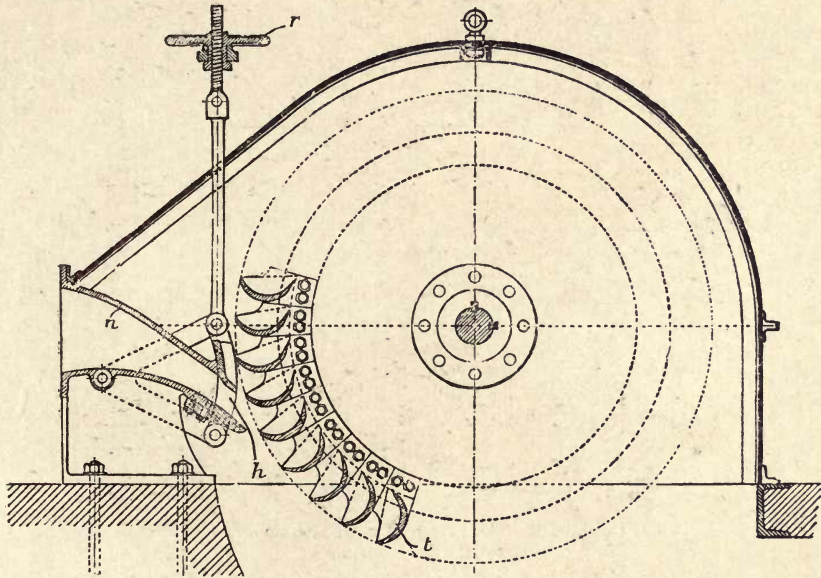

Fig. 340.—Hood Regulator used in Pitman Single-jet Impulse Turbines.

adjusted by the valve V to suit the particular grade of sugar to be treated, the time occupying from one to three or four minutes, after which one nozzle only is used, thus economising pressure water.

In the "Pitman" jet-action turbine the wheel is also enclosed in a circular casing, as in the turbine just described, but for another reason; in this case the nozzle is arranged with a swivel joint placed under the control of a governor by which means the jet can be deflected more or less from the wheel cups in proportion as the speed exceeds normal. This particular method of governing commends itself in one respect, to wit, in obviating the necessity for providing a relief valve to compensate for the effects of concussion, but is wasteful of pressure water at reduced loads, and however effectual in speed control, is not to be recommended where the supply is not plentiful.

To another method of governing turbines of the jet-action type—viz., that known as the Cassel system—this same remark applies, the full flow of water

being allowed to run under all conditions of load in this turbine as in the preceding. According to this system the nozzle is fixed, and directs the jet on to a spoon wheel, split in twain as it were, one-half being keyed fast to the driving shaft and fitted up as a powerful shaft governor, and the other arranged to slide along the shaft to and from the fixed half under the control of the governor, and in this manner causes the jet to be more or less ineffectual at reduced loads by moving the wheel cups out of its path.

However, to obviate this objection, a form of governor for jet-action turbines has been devised, in which more or less of the jet can be shut off by a hood as at (*h*), Figs. 340 and 341. According to this system (known also as the Pitman) the motor wheel (*t*), which is enclosed by a circular casing, can either be regulated by a hand wheel (*r*), as shown in Fig. 340, or by a relay hydraulic governor of the kind described (*vide* Fig. 336), in which connection for large powers two

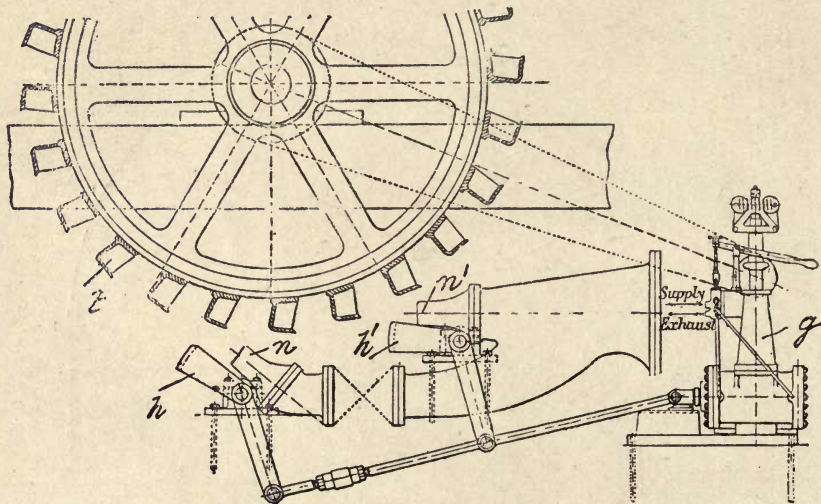

Fig. 341.—Pitman Impulse Turbine arranged with Double Jet Action controlled by Hydraulic Governor

or even three nozzles as at $n n^1$ can be synchronously controlled by hoods $h h^1$, a spring-loaded relief valve being fitted to the supply pipe close up to the nozzles.

Among other types of turbine governors that may be mentioned as being suitable for moderate powers, the Hetts governor takes a prominent place, this differing from most of the mechanical relay controlling apparatus in being actuated by a gear consisting of a pair of cone pulleys connected by a belt under the control sideways of a powerful fly-ball governor, by which means a differential speed is communicated to an epicycle train of wheels, and in this way the sluice can be controlled so as to increase or diminish the supply of water to the turbine.

The simple and effectual mechanical relay governor, illustrated in sectional elevation by Fig. 342, operates on the frictional relay system, and is a type better known as the Woodward governor, and is made either as shown or with composition-lined cones, and in the larger sizes with a relay purchase action between the cones and the governor, the two being separately driven. One form of the Woodward governor consists essentially of a pair of frictional discs S O connected

by means of pinions with the bevel wheel V, and a central driving disc D keyed fast to the governor spindle A. On the heavily-weighted governor R being run at a speed below normal, the pendulum weights will cause the disc D to contact with S and thus communicate a rotary movement to V and the turbine shaft T in a direction to increase the water supply; and on the speed exceeding normal the disc D will be depressed so as to contact with the friction disc O, and thereby communicate a motion in the opposite direction to the turbine sluice

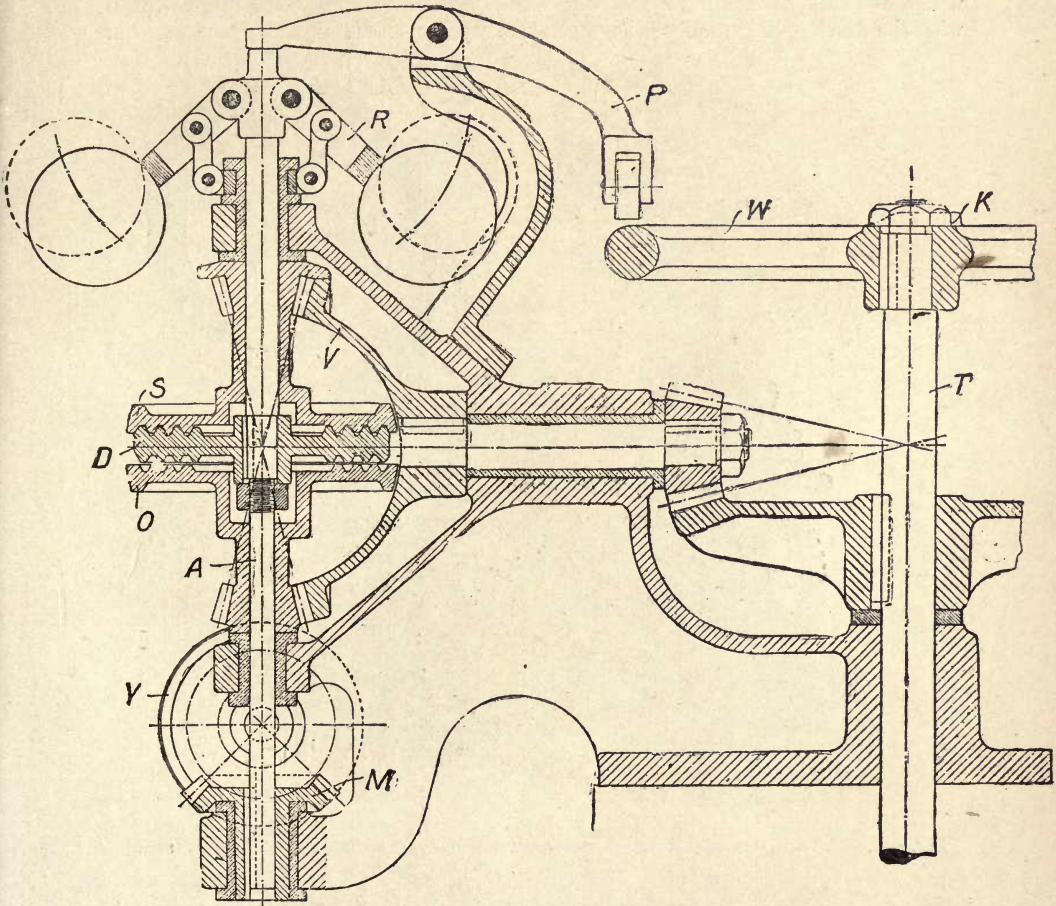

Fig. 342.—Turbine Relay Governor with Frictional Drive.

shaft T. In order to relieve the driving pulley Y and mitre gear M of undue strain, a cam K forming part of the hand-wheel W moves round so as to lift the lever P and thus depress the spindle A as soon as the turbine sluice is at full gate, when the driving disc D will be held in mid-position between the two discs S and O; a very limited vertical movement of the friction discs or cones suffices with a proportionately quick action. The photo-view (Fig. 343) shows this type of governor in another form, in which a small high-speed governor takes the place of the heavy fly-ball governor, the necessary purchase-power

for applying the friction cones being obtained by a relay gear actuated by a friction disc and train of gearing.

A usual method for controlling the speed of the smaller sizes of turbines when not required to be run under quick changes of load is some form of ratchet and pawl relay gear, such, for example, as used in the "King" governor illustrated by Fig. 344. The action of governors of this type, although powerful for their size, is comparatively slow, and, therefore, unsuitable for purposes where evenness of running is essential with load fluctuations, such as associated with the driving of dynamos; however, as they are so widely used in connection

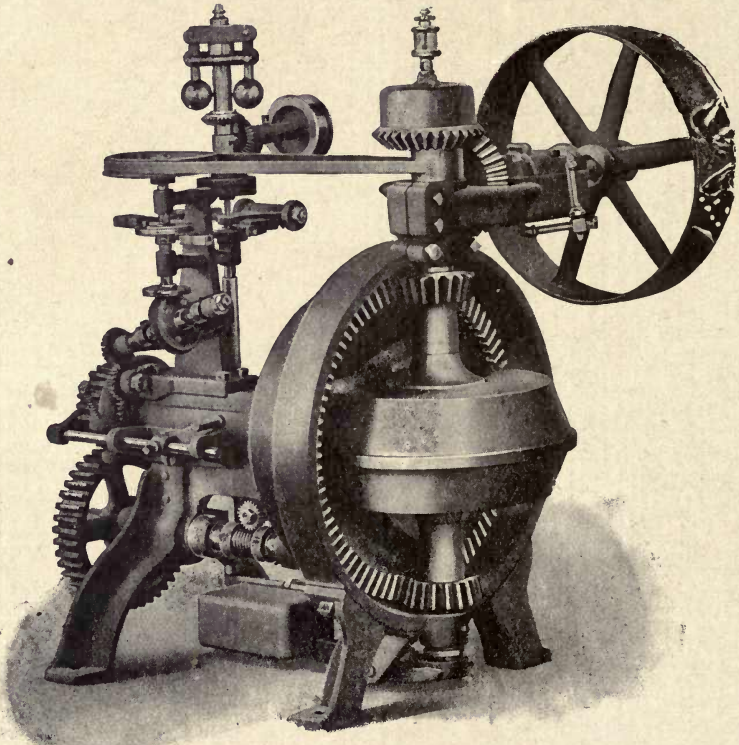

Fig. 343.—Friction-disc Quick-action Relay Turbine Governor fitted with Compensating Gear.

with the numerous other purposes for which this method of speed control is suitable, a description of one of these will be instructive. Referring to the illustrations:—A ratchet wheel (*h*) keyed to the turbine sluice shaft (*t*) is operated in either an opening or closing direction by means of one or the other of the pawls (*p*) carried by the quadrant arm (*q*), to which an oscillating movement is communicated by the eccentric (*x*) and driving wheel (*d*), the action of this governor being as follows:—On the speed of the pendulum (*g*) exceeding normal the governor spindle is raised, taking with it the rack (*k*) and weight (*w*); this movement communicates a rotatory movement to the shield (*r*) and frame (*f*) by means of the pinion shown, thus preventing either one or both of the

pawls (*p*) from engaging with the ratchet wheel (*h*), according to the position of the partly-rotated shield (*r*). This same principle is also applied to a governor (*vide* Fig. 345), in which the shield (4) is held in the position for either or both of the pawls (2) or (3) to be thrown out of action, by the vertical position of the float (5), the two pawls being carried by an oscillating frame actuated from a crank on the driving pulley. As in the preceding example, the ratchet wheel (1) is keyed to the turbine sluice shaft, and motion from the float is communicated to the shield by a rack and pinion gear. A float-controlled governor such

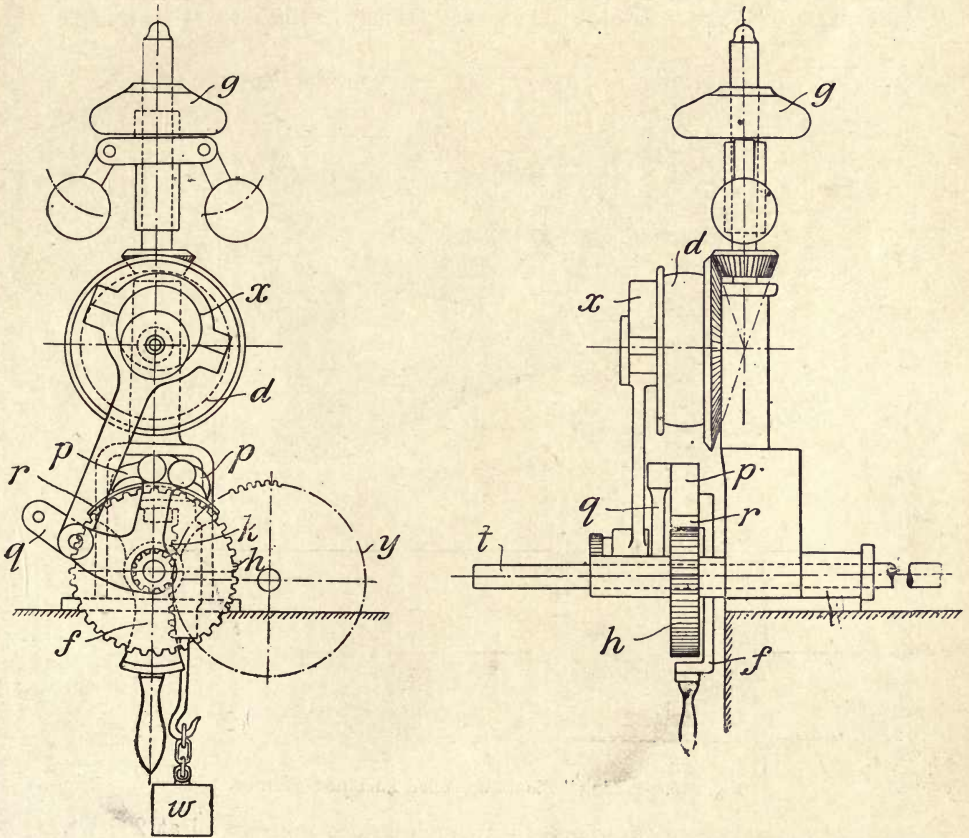

Fig. 344.—Turbine Governor with Ratchet Relay Movement.

as this can be usefully applied when a turbine is required to run in conjunction with either another turbine, a water-wheel, or even a gas, oil, or steam engine, and is arranged over or in connection with the reservoir supplying the turbine; the object of the float-controlled governor is, of course, to throw the auxiliary turbine motor out of action as soon as the water in the reservoir or other source of supply shall have fallen below a predetermined level, and in this way prevent water from being wastefully used at an inefficient pressure head.

Touching on the point of automatic control of hydraulic turbines, it will have been gathered from what has been already stated that mechanical relay

governors are not suitable for turbines of large power, and with the exception of the "Piccard" governors, are not used for powers exceeding 500 H.P., and more often than not for powers under 100 H.P. The reason for this is explained by the power required to control with sufficient celerity the pressure flow in large turbines. For the purpose of emphasising this statement, it is only necessary to instance the powerful pressure-oil "Lombard" governors employed to control the 12,000 H.P. turbines of the Ontario Power Company (*vide* Fig. 319), these having each a cylinder 14 inches diameter by 22 inches stroke, the piston of which is directly connected to the crown rings N used to command the control of the two series of swivel vanes G. It may be added that the available

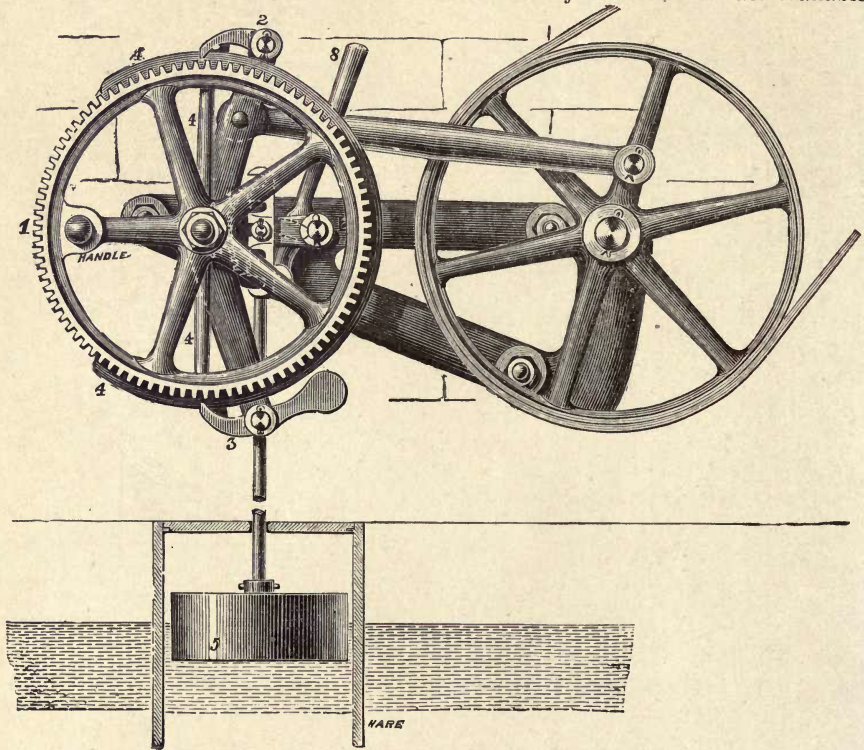

Fig. 345.—"King" Float-controlled Turbine Governor.

power of each of these governors when supplied with pressure oil at 200 lbs. per square inch, is such that a force in either direction equal to 14 tons can be directly applied in controlling the volume of pressure water flowing through each turbine.

In considering turbines of all classes from the point of view of governing amenity only, we find the greatest facility for speed control attaches to that class in which pressure water is directed on to the water periphery of the impeller, and at a velocity approximately equal thereto, and in which it takes a radial direction inwards, and either discharging at right angles or parallel to the axis. Now, as it has already been explained, we find that for the same reason that radial inflow reaction turbines are to a certain extent self-governing, and that an exactly opposite effect is produced in radial outward-flow or centrifugal turbines, for

in these the action of centrifugal force increases as the speed increases, with the effect that on a reduced load any resulting increase of speed of the impeller by augmenting the velocity of the water-flow outwards through the impeller imparts thereto an increasing reactionary effect instead of a decreasing one, as obtains in turbines of the radial-inflow class. As a consequence of this effect, outward-flow or Fourneyron turbines if unloaded may revolve at a higher peripheral velocity than the water flow thereto as produced by pressure head. In the case of Girard turbines, this effect may also be produced to a somewhat more limited extent, but with the tangential or jet-action class of turbines known as Pelton wheels, the peripheral speed can never exceed the velocity of the jet.

Other considerations to be taken into account in comparing the relative governing values of the Girard and Pelton high-pressure turbines are:—That the first named is generally provided with a series of jets extending round a portion of the inner periphery of the wheel—a disposition that lends itself to very efficient and regular governing by the simple expedient of cutting off the water flow by reducing the number of jets in action. Tangential turbines on the contrary, are found to afford a more efficient result when actuated by a single unbroken jet for each wheel than by a number of smaller jets of equal collective capacity, and for this reason the jet-action turbine, although of simpler construction and very economical when properly proportioned to its work, requires for its control a governor having a more powerful and regular action, and the wheel itself, as before explained, requires to be proportionately strong for an equal output.

In concluding this subject, by recapitulating the general application of each of the several classes and types of turbines described, we find that:—Radial mixed-flow “unenclosed” turbines provided with a draught tube are most suitable for falls not exceeding 50 feet, which for the smaller powers may be arranged vertically and have a single wheel, and for dealing with larger volumes of pressure water are more generally of the horizontal type, having a double wheel, both discharging into a common central draught tube (*vide* Figs. 307 and 309).

For falls exceeding 50 feet and under 300 feet, enclosed turbines provided with pressure-water flumes, and with radial inflow impellers of the Thomson or Francis type, or a combination of both, are most suitable. These may either have (1) a double discharge draught tube with a single wheel, and be arranged horizontally (*vide* Fig. 301); (2) have a single-discharge tube (*vide* Figs. 311 and 315); (3) have a double wheel with a double discharge tube (*vide* Fig. 320); or have a double wheel with a single central-discharge tube (*vide* Figs. 319 and 321), the turbines in each of these cases being arranged horizontally.

Turbines having impellers of the Thomson or Francis type are also adapted for being arranged vertically with enclosed guide vanes, and provided with a pressure-water flume for falls exceeding 50 feet and under 200 feet, in situations where it is inexpedient to use horizontal turbines, the choice being determined from considerations of space and the feasibility of locating the electric generator at the lower level. Vertical turbines of this class may have a double wheel (*vide* Fig. 322), or a single wheel (*vide* Fig. 324).

Radial-inflow Thomson turbines are controlled by a series of long, hinged guide blades (*vide* Figs. 300 and 301), and turbines with Francis mixed-flow impellers, whether of the vertical or horizontal type, are either controlled by a sluice ring arranged to slide between the impeller and a ring of fixed guide vanes (*vide* Figs. 302, 322, and 324), or are provided with a distributing ring.

having a closely-packed series of short swivel guide vanes, each connected up to an actuating ring, so that the complete series may be simultaneously opened or closed, the closing movement being performed against a like number of spring cushions to avoid undue strain (*vide* Figs. 307, 311, 315, and 319); or, again, be controlled by either throttling the ingoing pressure water or the discharge in the draught tube (*vide* Figs. 315 and 321). This latter method has, however, fallen into disuse owing to its causing the turbine to work with a lower efficiency at reduced loads, the sliding sluice ranking next in point of governing efficiency and the hinged or swivel vanes highest.

Outward-flow or Fourneyron turbines are always arranged vertically, and controlled by a sliding sluice located outside the impeller wheel (*vide* Figs. 327 and 330). Turbines of this class are suitable for falls of from 50 to 500 feet, but are not so well adapted for utilising the suction effect of a draught tube, and partly as a result of this the efficiency falls from 10 to 15 per cent. below turbines of the radial-inflow class.

Girard turbines are also of the outward-flow class, but differ from the Fourneyron in having the pressure flow distribution limited to from one-sixth to one-fourth of the inner circumference of the impeller (*vide* Figs. 331 and 332), and in being best adapted for the horizontal position. Girard turbines are suitable for falls of from 200 to 2,000 feet, and are used for purposes requiring a comparatively slow speed of rotation relatively to the water velocity due to pressure head.

Tangential-action or Pelton wheels, which when driven by a single jet are better arranged horizontally, and with multiple jets vertically, are adapted for pressures upwards to 5,000 feet; in fact, the pressure head under which this class of turbine may be used is limited principally by the holding power of the pipe line. Pelton, in common with Girard, turbines are always arranged to run with free deviation above the tail-water level (*vide* Figs. 335, 338, 340, and 341).

Now, from the variety of types and applications that have been adduced in the foregoing, there should be little difficulty in finding sufficient "data" and "example" for not only determining the relative adaptability of hydraulic to other powers—the most suitable type of generator to use for varying conditions of pressure-head, power requirements, and other factors met with—but also the underlying principles influencing the form and construction of such generator. And, further, from a due consideration of the very extensive and rapidly increasing application of hydraulic power, it must be conceded that the power efficiency and usefulness of the water turbine is not only exceedingly high, of vast and far-reaching importance, but goes to prove that water, so long as the source of supply is continuous and sufficiently near the point of application, is an almost ideal medium for converting the potential energy of pressure head into mechanical power—a conclusion that may be attributed (1) to the low coefficient of water frictional resistance, (2) to the absence of heat losses, (3) to its inelasticity and density, and (4) to the smooth and continuous action, perfection of working, and adaptability of the turbine.

APPENDIX I.

SOME RECENT WATER POWER INSTALLATIONS WITH INWARD-FLOW REACTION TURBINES.

Plant.	Country.	Year of Installation.	Working Head in Feet.	Output in B.H.P. per Unit.	Number of Units.	Speed in R.P.M.	Type.
Cataract Construction Co., Niagara.	U.S.A.	1895	136	5,000	10	250	Double enclosed vertical "outward flow,"
A. B. Glommens Traesliberi, Christiania.	Norway.	1901	65	3,000	4	150	Single enclosed vertical.
Shawinigan Water and Power Co., Montreal.	Canada.	1902	134	6,000	3	180	Double enclosed horizontal
Valtellina Electric Railway.	Italy.	1902	90	2,000	4	155	Single wheel horizontal.
Canadian Niagara Co.	Canada.	1903	133	10,250	11	250	Double enclosed vertical.
Svalgfors Power Station, Notodden.	Norway.	1904	150	11,750	3	250	Double enclosed horizontal.
Ontario Power Co., Niagara.	Canada.	1904	175	12,000	..	187	Double spiral horizontal.
M'Call Ferry Hydro-Electric Power Station.	U.S.A.	1905	53	13,500	10	94	Double open vertical.
Great Western Power Co.	U.S.A.	1907	525	18,000	4	400	Single spiral vertical.
Trollhattan Hydro-Electric Station.	Sweden.	1909	106	12,500	8	190	Double enclosed horizontal.
Tokio Electric Light and Power Co.	Japan.	1910	396	12,500	6	..	Double spiral horizontal.
Swawinigan Power Co.	Quebec.	1910	135	10,500	1	..	Double enclosed horizontal.
Keokuk Hydro-Electric Power Station, Mississippi.	U.S.A.	1912	39	14,000	15	57	Single open vertical.
Seattle and Taloma Co.	U.S.A.	1912	260	10,000	2	300	Single wheel horizontal.
Aelfkarleby Hydro-Electric Power Station.	Sweden.	1914	54	14,000	5	150	Quadruple open horizontal
Cedar Rapids Power Station, Montreal.	Canada.	1914	30	10,800	12	56	Single open vertical.
Alabama Power Co.	U.S.A.	1914	68	17,500	6	100	Single open vertical.
Laurentide-Power Station.	Canada.	1915	76	20,000	6	120	Single open vertical.
The Tallasee Power Co.	U.S.A.	1916	180	31,000	..	154	Single enclosed vertical.
Vamma Hydro-Electric Station.	Norway.	1919	80	12,000	6	21*	Double wheel horizontal.
"	"	1920	80	15,000	1	..	"

APPENDIX II.

SOME RECENT WATER POWER INSTALLATIONS WITH JET-ACTION OR IMPULSE TURBINES.

Plant.	Country.	Year of Installation.	Pressure, Head in Feet.	Maximum Output per Unit in H.P.	Number of Units.	Speed in R. P. M.	Type.
The Mexican Light and Power Co., Necaxa.	Mexico.	1903	1,279	8,200	6	300	4-jet vertical.
Brusio Hydro-Electric Plant.	Switzerland.	1905	1,350	3,500	12	375	Single-jet horizontal.
Rio de Janeiro Tramway, Light and Power Co.	Brazil.	1906	950	9,000	6	300	4-jet vertical.
British Aluminium Co. Ltd., Kinlochleven.	Great Britain.	1907	900	3,300	11	300	Double-jet horizontal.
Tysse Hydro-Electric Plant.	Norway.	1907	1,260	4,800	7	375	Single-jet horizontal.
Rjukanfos Hydro-Electric Plant, Station I.	Norway.	1908	930	14,450	10	250	4-jet twin runner horizontal.
Loentch Hydro-Electric Plant.	Switzerland	1908	1,075	6,000	4	375	Double-jet overhanging horizontal.
The Mexican Light and Power Co., Extension.	Mexico.	1909	1,279	16,000	2	300	4-jet vertical.
Biashina Hydro-Electric Plant.	Switzerland.	1909	850	11,000	3	300	4-jet vertical.
South California Edison Co., Kern River, Plant I.	U.S.A.	1910	865	10,750	4	250	2-jet twin runner overhanging horizontal.
Lake Bunzen Hydro-Electric Plant, Station II.	Canada.	1912	395	13,500	3	200	8-jet quadruple runner horizontal.
Kinugawa Hydro-Electric Plant.	Japan.	1912	1,050	6,000	6	375	Single-jet horizontal.
Rio de Janeiro Tramway, Light and Power Co. Extension.	Brazil.	1912	950	20,000	2	300	4-jet vertical.
Loentch Hydro-Electric Plant Extension.	Switzerland	1913	1,150	16,000	1	300	Double-jet overhanging horizontal.
Tata Hydro-Electric Plant, Bombay.	India.	1914	1,650	13,500	6	300	Single-jet horizontal.
Rjukanfos Hydro-Electric Plant, Station II.	Norway.	1914	830	16,400	10	250	4-jet twin runner horizontal.
Aura Hydro-Electric Plant.	Norway.	1916	2,350	23,500	6	250	Single-jet horizontal.
Hydro-Electric Power Co	Tasmania.	1919	1,100	10,000	7	..	Double-jet.

INDEX.

A

ABYSSINIAN wells, Boring appliances for, 84.
Acme rotary pump, 331, 332.
Air compressors, Efficiency of, 110, 129-132.
 ——— Electrically-driven, 114.
 ——— Gas- or oil-driven, 115.
 ——— Losses in, 110, 119, 120.
 ——— Steam-driven, 112, 113, 116.
Air-displacement pumps—
 For raising oil, 126, 127.
 ——— sewage, 251.
 ——— water, 254.
 Low efficiency of, 128.
Air-lift borehole pumps—
 Advantages of, 111, 129.
 Cost of, 115, 129.
 For raising petroleum, 129-133.
 ——— water, 108-120.
 General efficiency of, 115, 119, 132.
 Highest efficiency of, 120.
 Installations of —
 At Bembridge, I.W., 115.
 At Birkenhead, 115.
 At Kent Waterworks, 111, 115, 116.
 At oil fields, S. Russia, 129-132.
 At Skegness, 117.
 At Wandsworth, 119.
 At Westminster, 114.
 Origin of 116.
 Useful data *re*, 132.
 With adjustable immersion, 118.
 With concentric pipes, 112.
 With pipes side-by-side, 113, 114, 116.
 With taper-tube uptake, 118, 119.
Air-pumps, Condenser—
 Centrifugal, 230.
 Combined dry and wet, 225, 226.
 Cycloidal, 228.
 Double-acting, 218, 220.
 Ejector action, 231-234.
 Plunger action, 209-227.
 Rotary action, 227-234.
 Turbine action, 229.
 Valveless, 222-224.
 1-valve single-acting, 215, 217, 218, 219.
 2-valve single-acting, 212, 214.
 3-valve double-acting, 213, 226.
Ancients, Pumping methods used by. 1.

Appliances for raising petroleum from borehole wells—
 Air-displacement pumps, 126-128.
 Air-lift pumps, 129-132.
 Baler pumps, 123-125.
 Band elevator pumps, 133-136.
 Consideration and cost of, 121.
 Plunger pumps, 122.
Archimedean pumps for concrete, 329.
 ——— for irrigation, 1, 358.
 ——— for molasses, 328.
Argentina Waterworks, 25-27.
Artesian wells, Air-lift pumps for, 108-120.
 ——— Boring appliances for, 85-94.
 ——— Direct-acting pumps for, 105.
 ——— Double-acting pumps for, 108.
 ——— Double-plunger pumps for, Ashley, 101, 102.
 ——— Double-plunger pumps for, Con-
 certina, 17, 102.
 ——— Double-plunger pumps for, Downie,
 102.
 ——— Double-seated valve pumps for, 96.
 ——— Gas-driven pumps for, 98.
Ashley borehole pumps, 99-101.
 ——— with double plunger, 102.
 ——— with removable barrel, 100.
 ——— deep-level pumps, 65-66.
 ——— sinking pumps, 71.
Atmospheric pressure, Discovery of, 1.
Authors quoted—Davey, 236, 245; Fowler,
 W. H., 211; Innes, 375-376, 400, 404-405;
 Livens, Howard, 374; Parsons, Hon., 374;
 Stanton, Dr., 384; Unwin, 375.
Automobile propulsion, Hydraulic trans-
 mission for, 320-323, 325.
Auto-Motor Journal, Illustration and par-
 ticulars from, 308.

B

BALANCED-ACTION connecting gear, 57-59.
Balanced-pole dipper pump, 2.
Baler pumps, 2, 123-125.
 ——— Efficiency of, 124.
 ——— Useful data *re*, 124.
Band pumps, 133-135.
Barnett, East, Waterworks. 17.

- Barometrical ejector condensers, 206-208.
 Bassett Mines, Cornwall, 13.
 Beam pumping engines, Direct-acting, 6-14,
 42.
 ——— Rotative, 20, 21, 37.
 Beighton's improvements to Newcomen
 pumping engine, 17.
 Belt-driven pumps, 178-180, 280-286.
 Beaumont, Worby, Report by, 309.
 Bi-Therm air pump, 233.
 Boiler-feed pumps, Direct-acting—
 Steam required for, 138.
 Boiler-feed pumps, Direct-acting simplex—
 Blake-Worthington, 139-141.
 Bradford, 142, 143.
 Caird and Rayner, 145.
 Cameron, 146.
 Clarke-Chapman, 148, 149.
 Davidson, 150, 151.
 Karoome, 151, 152.
 Lamont, 152, 153.
 Nichols', 155, 156.
 Pearns', 156, 157.
 Storey, 158, 159.
 Voit, 161.
 Weir, 162.
 Woodeson, 148, 149.
 Worthington, 141.
 Boiler-feed pumps, Direct-acting duplex—
 Mumford, 167-169.
 Oddesse, 171-173.
 Worthington, 165, 166.
 Boiler-feed pumps, Turbine, 398.
 Boiler-feed pumps, Variable-delivery constant-
 speed—
 Clarke-Chapman, 317-320.
 Hayward-Tyler, 312-314.
 Thwaites, 315.
 Borehole plunger pumps—
 Ashley, 99-101.
 Concertina action, 102-104.
 Diagrams from, 106.
 Double-acting single-plunger, 108.
 Downie, 103.
 Methods for balancing—
 By counterpoise on beam, 99.
 ——— on crank, 98.
 By double plungers, 102.
 By quadrant levers, 99.
 By throttling the exhaust, 106.
 Boreholes, Size of, for testing, 85.
 ——— section under Birmingham, 105.
 ——— London, 98, 112, 113.
 Boring appliances, or boring-rigs—
 Beam percussion, 87, 88.
 Diamond drill, 91.
 Hand jumper, 85.
 Pole and trestle, 86.
 Rotary, with abrasive action, 92.
 Steam percussion, 86, 90.
 With walking beam, 87, 88.
 Boston Waterworks, Pumps used in, 35.
 ——— Drainage Works, Pumps used in, 37.
 Boulton and Watt, rotative beam engines, 16,
 17.
 Boulton and Watt, First and last engines by,
 16.
 Brighton Waterworks, Pumps used in, 65.
 Buda-Pesth Waterworks, Pumps used in, 43,
 46, 47.
 Bull direct-acting engine, 12, 13.
 Butler gas-displacement pump, 258.
 ——— hydrostatic air compressor, 120.
 ——— hydraulic ejector vacuum pump, 234.
 ——— distributor for air-displacement
 pump, 254-257.
 ——— oil elevator band pump, 135.
 ——— engine for mine pump, 68.
 ——— valveless condenser pump, 223, 224.
 ——— variable-delivery pump, 317, 318.
- C
- CAPRINGTON Colliery (Ayrshire), Newcomen
 pumping engine, 5.
 Cataract cylinder, Use of, in controlling gear,
 53, 55.
 Caxton House, Westminster, Pump used at,
 115.
 Centrifugal pumps—
 Comparison of static to kinetic energy in,
 375.
 Constructional diagram for, 377.
 Diagrams of, Efficiency—
 Showing effect of head to output in,
 362, 378, 379, 388, 392,
 394, 396.
 ——— of self-regulating, 379.
 ——— of speed to output, 394.
 ——— of throttled control in, 378.
 ——— working of Escher-Wyss 4-stage,
 396.
 ——— of Mather & Platt 4-stage,
 393.
 ——— of Rees-Roturbo, 379.
 ——— of Ruston irrigation, 362.
 ——— of Sulzer 6-stage, 388.
 ——— of Worthington low-lift, 378.
 ——— of Worthington high-lift,
 392.
 Early developments of, 372-374.
 Effect of diffusion chamber, 375.
 ——— of vane curvature, 374.
 ——— of vortex chamber, 375, 376.
 High-lift, Efficiency diagrams of, 388,
 392, 394, 396.
 High lifts for, 379.
 High-speed, 380, 381.
 Impellers used in, 359, 363, 364, 368,
 371, 373, 377, 379.
 Low-lift, 358-378.
 ——— Efficiency diagrams of, 362, 378,
 379.
 Multi-stage, 384-398.
 Pressure diagrams from, 378, 379, 388,
 392, 394, 396.
 Ratio of kinetic to pressure energy, 375.
 Rim velocity of impeller, 376.

- Centrifugal pumps—
 Self-regulating, 379.
 Starting methods used for, 382, 383, 392.
 Table showing relation of vortex chamber to size of impeller in, 376.
 Tables showing effect of working with diffusing chamber and without in, 375.
 Tables showing ratio of energies in, 375, 384.
 Tables showing efficiency of 4-stage "Invincible," 386.
 Theoretical considerations of, 374-378.
 Throttle control, Effect of, in, 378.
 Used for dredging, 367-371.
 ——— emptying docks, 364-367.
 ——— irrigation, 359-363.
 ——— sinking, 71, 388.
 Various methods used for balancing high-speed—
 Davey 4-stage, 390.
 Escher-Wyss 6-stage, 395.
 Gwynne 3-stage, 385.
 Hayward-Tyler 4 stage, 389.
 Laval single-stage, 380.
 Mather & Platt 4-stage, 393.
 Sulzer 6-stage, 387.
 Victoria 4-stage, 390.
 Worthington 3-stage, 391
 Volute, 359-372.
 Chain pumps, 328.
 Chatham Waterworks, Pumps used in, 19.
 Chicago Waterworks, Pumps used in, 35.
 ——— Drainage Works, Pumps used in, 360.
 Cincinnati Waterworks, Pumps used in, 33.
 Clarke - Chapman variable - delivery force pump, 316-319.
 ——— simplex boiler-feed pump, 148, 149.
 ——— valveless-duplex, 169.
 Coalbrookdale Iron Company, Atmospheric engines used by, 16.
 Compensators, Pressure—
 Davey differential, 57-59.
 Impulse turbine, 448, 449.
 Oddesse air spring, 49, 50.
 Worthington hydraulic, 39, 44-47.
 Compound pumping engines—
 Boulton & Watt, 16.
 Bull, 13.
 Cameron, 147.
 Clarke-Chapman, 149.
 Cornish, 14, 15.
 Davey, 14, 52-60.
 Glenfield, 21.
 Haarlem, 10.
 Holley, 36.
 Hornblower, 9.
 Nichol, 155.
 Oddesse, 49, 172.
 Prescott, 174.
 Simpson, 20.
 Sims, 9, 10.
 Trevithick, 10.
 Wilson-Snyder, 175.
 Woofe, 10.
 Worthington, 39.
 Concrete pump, 329.
 Condenser ejectors, 203-208.
 ——— pumps, plunger action, 209-227.
 ——— rotary action, 227-234.
 ——— separate, First use of, 5.
 Connersville rotary pump, 232-234.
 Consumption, fuel, Rate of, 3, 12, 15, 28, 34, 41, 132, 138, 203, 293, 294, 335.
 Coolgardie water supply, 38-40.
 Cornish beam pumping engines—
 Compound, 12, 14.
 Duty of, 12, 15, 293.
 Latest put down, 12.
 Used for London water supply, 12.
 Corrosive liquids, Pumps for, 180.
 Cowper, E. A., Report by, on Worthington pump, 41.
 Craig trip motion (expansion gear), 28.
 Creosote, tar, etc., Pumps for, 144, 165.
 Cylinder and piston, First suggestion of, 5.
- D**
- DAVEY compensator, 57-59.
 ——— differential pumping engines, 52-60.
 ——— hydraulic power pump, 236-238.
 ——— turbine pump, 320.
 ——— valve gear, 53-55.
 Deep-level pumps, Artesian, 95-136.
 ——— Ashley, 66.
 ——— Mine, 60, 62, 63.
 Denaby sinking pump, 68, 69.
 Diagrams, Constructional—
 Showing development of vane curvature in impeller of centrifugal pump, 377.
 Showing development of vane curvature in impeller wheels and guide passages of hydraulic turbines, 403, 406.
 Showing differential balancing gear, 57.
 ——— hydraulic balancing gear, 44.
 Diagrams, showing efficiency curves—
 Of constant-speed variable-delivery force pump, 313.
 Of turbine centrifugal pumps, 379, 388, 392, 394, 396.
 Of volute centrifugal pumps, 362, 378.
 Diagrams, showing expansion curves—
 Oddesse comp. engine, 50.
 Potter borehole pump, 106.
 Worthington triple-exapansion engine, 44.
 Diamond boring machines, 91.
 Diaphragm pumps, 180, 246, 377.
 Diesel oil engines, Advantages and use of, 364, 365.
 Differential non-rotative pumping engines, 52-60.
 ——— Compensating gears for, 57-59.
 ——— Diagrams of, 57.
 ——— Valve gear for, 52-55.
 Docks, Pumps for emptying, 364, 365.
 Double-acting air pumps, 218, 220, 225.
 Drainage pumps, 37, 251, 357-367.
 Dredging pumps, 367-371.
 ——— steamer, 369, 370.

- Drum rotary pumps, 330-336.
 Dry and wet air pumps, Combined, 225, 226.
 Dual air pump, 226, 227.
 Dudley Castle, First Newcomen pump at, 5.
 Duplex pumping engines—
 Brooklyn water supply, Used for, 45.
 Buda-Pesth water supply, Used for, 43, 46, 47.
 Chicago water supply, Used for, 48.
 Compound, 39, 49, 50.
 Coolgardie water supply, Used for, 38-40.
 Deane, 48.
 Epping-Carpenter, 174.
 Heisler, 175.
 London water supply, Used for, 40-42.
 Oddesse, 49, 50, 172.
 Prescott, 174.
 Triple-expansion, 42, 44-47
 Wilson-Snyder, 48.
 Worthington, 38-47.
 Duplex general service pumps—
 Anthony-Mumford, 167-169.
 Beaver differential, 170, 171.
 Clarke-Dowson, 169.
 Deane, 166
 Epping-Carpenter, 174
 Fielding, 171.
 Heisler, 175
 Lee-Howl, 172.
 Prescott, 174.
 Wilson-Snyder, 175
 Worthington, 165.
 Dynamic-action vacuum pumps—
 Bodmer, 217.
 Borsig, 214.
 Butler, 222-224.
 Edwards, 215-217.
 Fraser, 225.
 Heisler, 220.
 Paxman, 225.
 Stott, 219.
 Worthington, 218.
 Zylinderlast, 220

E

- EARLIEST methods for raising water, 1, 2, 4, 5.
 Early direct-acting steam pumping engines—
 Bull, 13.
 Cornish, 11.
 Davey, 14.
 Haarlem, 10.
 Newcomen, 5-8.
 Sims, 10.
 Trevithick, 10.
 Watt, 9.
 Early service mains, 235.
 — water supply pumps, 235.
 Ejector condensers—
 Barclay, 204.
 Barometrical, 206, 207.
 Bulkley, 206.
 Körting, 205.

- Ejector condensers—
 Ledward, 205.
 Mazeline, 204.
 Morton, 204.
 Table showing working of, 207.
 White, 206.
 Worthington, 208.
 Ejector pumps—
 Bilge water, 203.
 Kinetic, 233.
 Tables showing working of, 202.
 Theory of, 202
 Electrically-driven pumps—
 Artesian well, 114, 135.
 Three-throw plunger, 290-292.
 Turbine, 71, 395.
 Variable-delivery, 313, 317, 318.
 Elevator pumps for raising petroleum—
 Butler, 135.
 Leinweber, 134.
 Pedley, 133.
 Elm trunks, Use of, for rising mains, 2, 235.
 Endless-chain pumps, 2, 328.
Engineering, Illustrations and particulars from, 6, 119, 324, 355.
Engineering Review, Illustrations and particulars from, 121-136.
 Enke rotary pump, 336.
 Expulsor pumps, 250.

F

- FARME Colliery (Glasgow), Newcomen pumping engine at, 5.
 Fielding & Platt gas engine for pump, 298.
 Filling-valve, First use of, 2.
 Fire pumps, fire engines—
 Duple crane-controlled steam, 267-271.
 Hatfield 3-throw, 271-274, 298.
 Jet capacity of, 270.
 Lane-Eland rotary, 345.
 Merryweather duplex, 268, 269.
 — petrol fire engine, 271.
 — fire-float, 274.
 Motor fire engines, 271-275.
 Power of, 270.
 Ram and plunger, 276.
 Shand-Mason duplex steam, 267
 Steam, Oil used for, 270.
 Tottenham petrol fire engine, 275.
 Variable-delivery, 310, 311.
 First application of gas power for pumping, 5.
 — of hydraulic power for pumping, 235.
 — of steam power for pumping, 4
 Flap valves—
 Gutermuth spring, 76.
 Metal-backed leather, 79.
 — rubber, 76.
 Flat-seated valve, multiple disc, 77.
 Flywheel pumps—
 Belt-driven, 178, 179, 180, 280-286.
 Constant speed variable delivery, 178, 300

- Flywheel pumps—
 Fire engine, 267-276.
 Gas-driven, 294-299.
 General service, steam, 176, 177.
 High-speed, 277-299.
 Waterworks, 16-37.
- Force pumps—
 Belt-driven, 178-180, 280-286.
 Electrically-driven, 71, 114, 135, 289-293,
 313, 317, 318, 395.
 For concrete, 329.
 For corrosive fluids, 180.
 For creosote and thick fluids, 144, 165.
 For hydraulic pressure, 174.
 For mascuite, 326-330.
 For petroleum, 175.
 Gas-driven, 296, 297.
 Oil-driven, 271-276.
 Rotary, 322, 340.
 Variable-delivery, 303-306, 310-320.
- Formulæ, 184, 211, 236, 245, 377, 378, 403,
 404, 405, 406.
- Fottinger hydraulic transmission, 323-325.
- Fowler's *Mechanical Engineers' Pocket-Book*,
 Reference to, 211.
- Fraser and Chalmers' high-speed pumps,
 289-293.

G

- Gas power direct displacement pumps—
 Butler, 258, 259.
 Humphrey, 260-266.
 Joy, 259.
- Gas power waterworks engines—
 Direct-connected, 294-296.
 Gear-connected, 297-299.
- Gas power accumulator pumps, 295-297.
- Geared pumping engine (steam), 22-24.
- General service pumps—
 "Direct-acting simple" type—
 Blake, 139, 140.
 Blake-Knowles, 140.
 Blake-Worthington, 141.
 Bradford, 142, 143.
 Burnham, 143, 144.
 Caird and Rayner, 145.
 Cameron, 146, 147.
 Carriburn, 157.
 Clarke-Chapman, 149.
 Davidson, 150, 151.
 Karoome, 151.
 Lamont, 152.
 Marsh, 69.
 Michael, 153.
 Nichol's, 154, 155.
 Pearn's, 156.
 Richardson, 157.
 Storey, 158, 159.
 Tangye, 159, 160.
 Voit, 161.
 Weir, 162, 163.
 Weston-Parker, 157.
 Wilson-Snyder, 163-165.
 Woodeson, 148, 149.

- General service pumps—
 Worthington, 140, 141.
 "Direct-acting duplex" type—
 Anthony-Mumford, 167-169.
 Clarke-Dowson, 169.
 Deane, 166.
 Epping-Carpenter, 174.
 Fielding and Platt, 169-171.
 Heisler, 175.
 Lee-Howl, 171-173.
 Maxwell-Beaver, 170, 171.
 Mumford, 167-169.
 Oddesse, 171-173.
 Prescott, 174.
 Wilson-Snyder, 175, 176.
 Worthington, 165, 166.
- "Flywheel" type—
 Baillet-Audemar, 180.
 Cameron, 177.
 Diaphragm, 180.
 Hamilton, 179.
 Pearn's, 177.
- "Variable-delivery constant-speed type"
 Clarke-Chapman, 316-319.
 Hele-Shaw, 321-323.
 Sinclair, 311-313.
 Thwaites', 314, 315.
- Gill valve, Rubber-ring, 79.
 ——— Witting, 77.
- Governing methods used in hydraulic tur-
 bines—
 By cut-out jet action, 443, 444, 452, 454.
 ——— Fink guide vanes, 423, 427.
 ——— hand-regulated guide blades, 408,
 409, 416, 417.
 ——— sluice gate, 400.
 ——— ring, 419, 420.
 ——— motor-regulated guide blades, 422-
 430.
 ——— sluice ring, 410, 419, 432-442.
 ——— throttle-regulated draft tube, 431.
 ——— variable jet action, 448-451.
- Governors used for turbines—
 Centrifugal, friction relay, 455, 456.
 ——— pressure oil relay, 412, 413, 421-430.
 ——— pressure water relay, 442, 448, 450,
 451, 454.
 ——— ratchet relay, 438-440, 457.
 Float-controlled cut-out, 452.
 Float, ratchet relay, 458.
 Porter's, in combination with pressure
 relay, 441.
- Governors used for waterworks engines—
 Hydraulic, 28.
 Porter centrifugal, 21.
- Grand Junction Waterworks, Duplex engines
 at, 40.
 ——— Rotative engines at, 16.
- Grel cut-off valve for pulsator pumps, 74.

H

- HAARLEM LAKE, Drainage of, 12.
 Hall's hydraulic transmission, 307-309.

- Hathorn, Davey & Co., rotatory waterworks engines, 25-29, 31-34.
- Haystack boilers for Newcomen engines, 5.
- Hayward-Tyler pumps, 311-313, 387.
- Hebden Colliery, Joicey rotative engine at, 18.
- Hele-Shaw variable delivery reversible-flow force pump, 321-323.
- Hele-Shaw Fontaine hydraulic transmission, 321.
- Helical or screw pumps, 328, 329, 358.
- Heisler duplex pump, 40.
- High-duty duplex compensated pumps, 39, 46, 47, 49.
- High-duty duplex compensated pumps, Diagrams of, 44, 50.
- High-speed plunger pumps—
 "Belt-driven type"—
 Barclay, 282-286.
 Haste, 287.
 Riedler, 279-281.
 "Crank and flywheel type," steam-driven—
 Southwark, 277.
 "Electrically-driven"—
 Fraser and Chalmers', 289-293.
 "Gas-driven"—
 Siegen direct-connected force pump, 296, 297.
 Snow Waterworks engine, 294, 295.
- Holly rotative duplex engine, 36, 37.
- Hornblower's improvement to Newcomen engine, 7.
- Hornsey, New River Waterworks engines, 35.
- Humphrey gas pumps—
 For high lifts, 265.
 For Metropolitan Water Board, 265, 266.
 Report on, 264.
 To work on 4-stroke cycle, 260-262.
 ——— on 2-stroke cycle, 264.
- Hydraulic motors—
 Föttinger, 323, 324.
 Governing of, 237, 306-309, 340, 341.
 Hall, 307-309.
 Hele-Shaw, 321-323.
 Pittler, 340, 341.
 Reversible, 321-323, 340, 341.
 Rotary, 340, 341.
 Revolving cylinders with, 307-309, 321-323.
 Turbine principle on, 323, 324.
- Hydraulic power pumps—
 Air-chamber charging apparatus for, 238.
 Davey Mine, 237.
 London water supply, for, 235.
 Relay or booster, 240.
 Uses of, 235, 236.
- Hydraulic rams—
 Belier, 241, 246.
 Blackburn, Waterworks at, 245.
 Blake, 247.
 Durozoi, 241, 246.
 Early forms of, 241, 242.
 Efficiency of, 245.
- Hydraulic rams—
 Glenfield, 244.
 Keith and Blac'man, 243, 244.
 Leblanc, 241.
 Proportions of, 245.
 Selection of, 247.
 Syphon, 242.
 Theory of, 245.
 With diaphragm pump, 245, 246.
 With force pump, 246, 247.
- Hydraulic power wheels—
 Breast, 399, 400.
 Overshot, 399, 400.
 Undershot, 399, 400.
- Hydraulic turbines—
 Diagonal-flow, 411-413.
 Impeller wheels used in, 403, 406, 408, 414, 444, 445.
 Impulse, 445, 454.
 Jet-action, 443-454.
 Outward flow, 437-442.
 Parallel flow, 406, 407.
 Radial-axial flow, 414-436.
 Theoretical aspects of, 402-407.
 Various types of, 401, 402.
 Vortex, 408-411.
 Water available for, 401.
 With axial flow, 407.
 With centrifugal flow, 437-444.
 With conical flow, 411-413.
 With mixed flow, 414-437.
- Hydraulic variable transmission—
 Advantages of, 321.
 Compagne, 321.
 Efficiencies of, 325.
 For automobiles, 321-325.
 For mine pumps, 236, 237.
 For relay service pump, 240.
 Föttinger, 323-325.
 Hall, 307-309.
 Hele-Shaw, 321-323.
 Methods of, 325.
 Pittler, 341, 342.
 Report on, 309.

I

INJECTORS—

- Combination, 187-189.
 ——— Brook, 187, 188.
 ——— Buffalo, 189.
 ——— White, 187.
 Compound, 192-200.
 ——— Albion, 192.
 ——— Holden & Brooke, 200.
 ——— Metcalfe, 197, 198.
 Diagrams, Efficiency of, 184.
 Double tube, Buffalo, 193.
 ——— Körting, 194.
 Early forms of, 182-186.
 Effect of air leakage in, 186.
 Exhaust, Mansfield, 200.
 ——— Schaffer and Budenberg, 200.
 First use on a locomotive, 182.

Injectors—

- Giffard, 182-186.
 Mansfield, 183.
 One-movement, Brooke, 187, 188.
 — Buffalo, 189.
 — White, 187.
 Plunger pump, Comparison with, 203.
 Re-starting, Friedmann, 190.
 — Gresham, 195.
 — White, 135, 196.
 Sharp-Stewart, 182.
 Simplex, Brooke, 196.
 Split-cone, Metcalfe, 197, 198.
 — Schaffer & Budenberg, 189.
 Tables, Showing delivery of, 185, 186.
 — — — working of, 185, 186.
 Theory of, 203.
Inst. Civil Engineers, Proceedings of, Illustrations and particulars from, 216, 217.
Inst. Mech. Engineers, Proceedings of, Illustrations and particulars from, 10, 13, 36, 54, 56, 62, 63, 78, 79, 96, 259, 260-262, 374, 429, 432.
 Irrigation pumps—
 Archimedean, 358.
 Centrifugal, Farcot, 358, 359.
 — Gwynne, 360, 361.
 — Ruston & Proctor, 362.
 — Sulzer, 360.
 Norias, 357.
 Rotary, Connorsville, 333-335.
 Scoop wheel, 357.
 Isler gas-driven borehole pump, 98.

J

JET pumps—

- Comparison with plunger pumps, 202.
 Friedmann, 203.
 Tables, Showing delivery of, 202.
 Theory of, 202.
 White, 201.
 Joicey rotative engine without flywheel, 18.
 Johannesburg Waterworks engines, 31.

K

- KEMPE'S *Engineers' Year-Book*, Reference to, 211.
 Kent Waterworks, Air-lift pump at, 111.
 Kettering Waterworks engine, 56.
 Kinetic energy of water, Ratio of, to static, 375.
 — — — — — Effects of, 12, 48, 236, 239.
 — — — — — Use of, 227-231, 234, 241, 257-266, 287, 357-450.
 Krieg oil fields (Galicia), Pump for, 133.
 Körting pulsator pump, 73.
 — — — direct-displacement pump, 253.

L

- LAVAL high-speed centrifugal pump, 380.
 Lamplough eccentric displacer pump, 346.
 — helical-gear pump, 337.
 — revolving-shuttle pump, 344.
 Largest reciprocating pump, 37.
 — hydraulic turbine, 430.
 Leeds Waterworks engine, 26.
Le Genie Civil, Illustrations and particulars from, 240, 246, 359.
 Lift pump, Earliest, with bucket piston, 2, 235.
 London's first water distribution system, 235.
 Low-lift centrifugal pumps—
 For dredging, 367-371.
 For emptying docks, 364.
 For irrigation, 358-363.
 For town drainage, 366.
 Impellers used for, 364, 368, 371, 377.
 Lubricating pumps—
 With eccentric-shuttle action, 346.
 With revolving-shuttle action, 344.
 With rotary gear wheels, 337, 338.
 With sliding-vane action, 339.

M

- MARINE propulsion, Hydraulic transmission for, 323-325.
 Marquis of Worcester steam pump, 4.
 Marsh sinking pump, 69.
 Masse-cuite pumps, 326-330.
 Mather & Platt boring-rig, 88-90.
 — — — — — turbine pumps, 393-395.
 Mechanically-actuated valves—
 For air pumps, 220-225.
 For high-speed pumps, 280-286.
 For waterworks pumps, 277.
 Merryweather fire engines, 271.
 — fire-float, 274.
 — fire pumps, 268-274.
 — variable-stroke fire pump, 310.
 Metropolitan Water Board, 12, 16, 29, 35, 40, 41, 265, 266.
 Mine pumps, 5-15, 61-65, 235-238.
 Molasses, Pumps for, 326-330.
 Montgolfier's hot-air pulsator pump, 4.
 Multiple-disc, flat-seated valve, 77.
 — mitre-seated valve, 78.
 — rubber-faced valve, 78.
 Multiple-gill, or rubber-ring, valve, 79.
 Multiple-stage centrifugal pumps (balancing methods used in)—
 By ball-bearings, 395.
 By double-eye impellers, 385.
 By double-suction and central discharge, 389, 390.
 By impellers in pairs, 387.
 By piston at pressure end, 398.
 — — — — — at suction end, 393.
 By piston for each impeller, 391.
 Diffusion vanes, Advantage of, 384.
 Efficiency curves, 388, 392, 394, 396.

- Multiple-stage centrifugal pumps (balancing methods used in)—
 Pioneers of, 385.
 Regulating by throttle control, 392.
 Tests of, 386.
 Various considerations for, 397, 398.
- N**
- NEWCOMEN, THOS., pioneer of piston pumping engine, 5-7.
 — pump, at Ashton Vale (Bristol), 6.
 — at Chacewater (Cornwall), 6.
 — at Low-Walker (Newcastle), 6.
 — Description of, 5-7.
 — Improvements in, Beighton, 7.
 — Hornblower, 7.
 — Potter, 7.
 — Smeaton, 7.
 — Watt, 7.
 — Model of (Patents Museum), 5.
 — still in existence, 5.
 Newman's variable-stroke pump, 303.
 New-River Waterworks engine (Hornsey), 35.
 — (Stoke-Newington), 41.
 New York Harbour, Dredging of, 369-371.
 — Zealand, Gas pumps for, 297-299.
 Non-rotative pumping engines, Duplex, 30-51.
 — Simplex, 52-60.
 Norias wheels, 357.
 North-Eastern Marine Engine Company, Pumps by, 29.
 Nuneaton, Newcomen pumping engine at, 5.
- O**
- ODDESSE Waterworks engine, 49.
 — Diagrams of, 50.
 Oddie air-spring compensator, 49.
 — -Barelay high-speed pumps, 282-286.
 — rotary pump, 344.
 Oil-fuel driven pumps, Advantages of, 67, 270, 293, 364, 365.
 Orr, Prof., Report by, 33, 34.
 Oscillating pumps—
 With double action, 349.
 With quadruple action, 348.
 With triple action, 350.
- P**
- PAPIN gunpowder vacuum pump, 5.
 Patcham Waterworks engine (Brighton), 32, 33.
 Patents Museum (Kensington), Newcomen pump at, 5.
 Patent Office, the, Illustrations from, 373, 379.
 Percussion boring machine with flat rope, 89, 90.
 — with pole and trestle, 86.
 Percussion boring machine with round rope, 87, 88.
 — with walking beam, 87, 88.
 Peter Morice, London's first water supply engineer, 235.
 Petroleum. Appliances for raising—
 By air-displacement pumps, 126-218.
 By air-lift pumps, 129-135.
 By baler pumps, 123-125.
 By elevator pumps, 133-135.
 By plunger pumps, 122.
 Petroleum, Output of, 121.
 — wells, Depth of, 121.
 — Section of, 125-130.
 Petrol-motor pumps, 270, 271, 274, 275.
 Philadelphia Waterworks engine, 33.
 Pittler hydraulic transmission, 339-341.
 — rotary pump, 339, 340.
 Plunger pumps, bucket, 6, 7, 9, 96.
 — and plunger, 20, 59, 62, 64, 66, 69, 71, 98, 99, 105.
 — double-bucket, 102, 104, 180.
 — piston, 39, 42, 45-47, 140-142, 145, 149, 151, 153-155, 161, 165, 166, 167, 170, 179, 180.
 — ram, double, 49, 174, 178.
 — double-acting, 65, 174, 175, 177.
 — hollow, 63.
 — and plunger, 21.
 — single, 11, 14, 23, 24, 26, 27, 30-32, 35-37, 62, 177.
 Pneumatic ejectors, 251, 252.
 Portsmouth Harbour, Geared pump for, 22.
 Potter borehole pump, 105-107.
 — rotary boring-rig, 92-97.
 Potter's improvement to Newcomen pump, 7.
 Price's taper tube air-lift pump, 118, 119.
 Pulsator pumps, "Air" direct-acting—
 For raising petroleum, 126, 127.
 — sewage, 251.
 — water, 254-257.
 Pulsator pumps, "Gas" direct-acting—
 Butler, 258-260.
 Humphrey, 260-266.
 Joy, 259, 260.
 Pulsator pumps, "Hot-air" direct-acting—
 Montgolfier, 4.
 Pulsator pumps, "Hydraulic" direct-acting—
 Belier-Durozoi, 246.
 Glenfield, 244.
 Keith, 243.
 Leblanc, 242.
 With diaphragm pump, 246.
 With plunger pump, 246.
 Pulsator pumps, "Steam" direct-acting—
 Brooke, 249, 250.
 Erwin, 248, 249.
 Körting, 73, 253.
 Pulsometer, 72-74.
 Savery, 4.
 Worcester, 4.
 Pulsometer pump, 72-74.
 Pump-trees, Origin and use of, 2, 235.

- Pyramidal valve, flat-seated, disc, 77.
 ———— hinged, 78.
 ———— mitre-seated, disc, 78.
 ———— rubber gill, 79.

Q

- QUADRUPLE-SEATED ring valve, 75.
 Queen Anne Mansions (Westminster), Pump at, 104-106.
 Queen Lane Waterworks engines, at Philadelphia, 36.
 Quinton Archimedean pump, 328.

R

- RAND Waterworks engines (Johannesburg), 29, 30.
 Reclamation work in Egypt, 360, 361.
 Report on working of Leeds pumping engines, 28, 29.
 ———— of Johannesburg pumping engines, 34.
 ———— of New River pumping engines, 41.
 ———— of West Middlesex pumping engines, 41.
 ———— of hydraulic transmission, 309.
 ———— of Humphrey gas pumps, 264.
 ———— of Oddie-Barclay high-speed pumps, 285.
 ———— of rotary Connersville pumps, 335.
 ———— turbine Invincible pump, 386.
 Restler, Mr. James, Engines designed by, 29.
 Rice irrigation, Pumps for, 334.
 Riedler high-speed pumps, 279-281.
 Rigg high-speed pumps, 276.
 Ring valve, Double-seated, 80, 96
 ———— Quadruple-seated, 75.
 ———— Triple-seated, 64.
 Riverdale pumping engines (Hampton), 29, 30.
 Rosario Waterworks engines (Santa Fé, S.A.), 27.
 Rotary air pumps—
 Butler ejector, 233, 234.
 Connersville cycloidal, 227, 228.
 Kinetic, 232, 233.
 Leblanc-Westinghouse, 229.
 Rees centrifugal, 230.
 Worthington hydraulic, 231.
 Rotary pumps—
 Acme, 331, 332.
 Albany, 337.
 Archimedean, 328, 329.
 Colebrook, 344.
 Connersville, 333-335.
 Drum, 330.
 Enke, 336.
 Gear wheel, 337.
 Goldsmidt, 334.
 Greindl, 334.

Rotary pumps—

- Hele-Shaw, 321, 323.
 Lamplough, 343, 344, 346.
 Lane-Eland, 345.
 Pittler, 340-342.
 Oddie, 344.
 Quinton, 328.
 Triben, 328.
 Willesden, 337.
 With axial sliding vanes, 339.
 With eccentric action, 346.
 With lung action, 345.
 With part centrifugal action, 344.
 With radial sliding vanes, 339.
 With revolving barrels, 306, 321-323, 347.
 With roller action, 344.
 With shuttle action, 344.
 Rotary well boring machines—
 With diamond cutter, 91.
 With tube cutter, 92.
 Rotatory class waterworks engines—
 Argentina, 25.
 Boston, U.S.A., 34.
 ——— main drainage, 37.
 Chatham, 19.
 Chicago, U.S.A., 34.
 Cincinnati, U.S.A., 33.
 East Barnet, 17.
 Gas power, 295.
 Glenfield, 21.
 Grand Junction (Middlesex), 16.
 Hornsey (London), 34.
 Johannesburg, 31.
 Leeds, 26.
 Philadelphia, U.S.A., 33, 35, 36.
 Rand, 32, 33.
 Rotative duplex, 36.
 St. Louis, U.S.A., 34.
 Shoreham, 22.
 Streatham, 16, 17.
 With parallel motion, 21.
 With slide pump valve, 227.
 Roto-plunge pump, 346, 347.
 Royal Agricultural Society, Trials by, 353, 354.
 Ruston & Proctor centrifugal pumps, 362, 363.

S

- SCOOP-WHEEL pumps, 1, 357, 358
 Screw pumps for drainage work, 2, 358.
 Separate condenser, First use of, 5.
 Shand-Mason fire pumps, 267-269.
 Siegen-Körting gas-power force pump, 295-297.
 Simplex pumping engines, 52-60.
 ——— pumps, 137-165.
 Simpson pumping engines, 18, 19, 20, 38-47.
 Sinking pumps—
 Brooke, 249.
 Korting, 73.
 Marsh, 69.
 Pulsometer, 72.

- Sinking pumps—
 Scott & Mountain, 71.
 Sulzer, 388.
- Siphon hydraulic-ram pump, 242.
- Skegness Waterworks, Air-lift pump at, 117.
- Smeaton's improvement to Newcomen engine, 7.
- Snow Company Gas-power Waterworks pumping engine, 294, 295.
- Solomon de Claus, first inventor of steam power for pumping, 1.
- South Staffordshire Waterworks engine, 58.
- Southwark high-speed pumping engine, 277.
- Springwell Colliery (Durham), Oil-driven pump at, 68.
- Steam-displacement pumps—
 Brooke, 249-250.
 Erwin, 249.
 Körting, 73, 253.
 Pulsometer Company, 73, 74.
 Savery, 4.
 Worcester, 4.
- Strata under Birmingham, 105.
 ——— London, 98, 112, 113.
- Streatham Waterworks, Engines at, 16, 101.
- Suction and delivery valves—
 Beehive, triple tier, 75.
 Butterfly, leather flap, 63, 79.
 Composite disc, 81.
 Flapper, 76, 288-292.
 For air pumps, 221.
 For fire pumps, 273
 Grid, 81.
 Mechanically-actuated, 277-286.
 Mitre, 80.
 Multiple-disc, 77.
 Multiple-gill, 77, 79.
 Pyramidal, 78, 79.
 Ring, 64, 75, 80.
- Sugar pumps and conveyors, 326, 327, 328, 329, 330.
- Sulzer irrigation pumps, 360.
 ——— turbine pumps, 387, 388.
- T**
- TABLES showing working efficiencies of—
 Archimedean pumps, 351.
 Baler pumps, 124.
 Duties of various pumping engines, 293.
 ——— pumps, 293.
 Ejector-condensers, 207.
 High-lift centrifugal pumps, 384, 386.
 Humphrey gas pump, 263.
 Injectors, 185, 186.
 Jet pumps, 202.
 Low-lift centrifugal pumps, 375, 376, 384.
 Oscillating pumps, 351.
 Rotary pumps, 351.
 Wind-power pumps, 253, 254.
- Tasmanian gold mines, Pumping engines used in, 60.
- Tests, Results of, made with—
 Air-lift pump for water, 115, 119.
- Tests, Results of, made with—
 Air-lift pumps for petroleum, 132.
 Centrifugal pumps, 362, 375, 376, 386.
 Davey waterworks engines, 28, 29, 34.
 Hall hydraulic transmission, 309.
 Humphrey gas pump, 264.
 Oddie-Barclay high-speed pump, 285.
 Pittler hydraulic transmission, 342.
 Rotary irrigation pumps, 335.
 Turbine pumps, 384, 386.
 Worthington high-duty pumping engines, 41.
- Technical High School, Berlin, Air-lift pump at, 116.
- The Engineer*, Illustrations and particulars from, 14, 29, 230, 275, 296, 357, 426.
- Theory of air-lift pumps, 110, 116, 119.
 ——— of boiler-feed pumps, 138.
 ——— of centrifugal pumps, 374-377.
 ——— of hydraulic rams, 245.
 ——— of injectors, 203.
 ——— of jet pumps, 202.
 ——— of rotary-ejector air pump, 233.
 ——— of turbine pumps, 384.
- Theoretical aspects of hydraulic power, 402-407, 418, 446, 447.
- Thom boring-rig, 86.
- Thomson, Thos., Report by, 28.
- Three-crank waterworks engines, 25-27, 30-32, 35.
- Thwaite variable-delivery pump, 315.
- Tranent Collieries, Pumping engines used in, 56.
- Transmission, Hydraulic—
 For automobiles, 307-310, 320-322.
 For gas power, 257, 258, 265.
 For marine propulsion, 323-325, 341.
 For mine pumps, 236-238.
 For valves, 256, 277, 278.
- Triple-expansion waterworks engines—
 American, 35.
 Davey differential, 59.
 Hawthorn-Davey, 25-28, 31-34, 59, 60.
 Johnston, 32.
 Restler, 30.
 Simpson, 18.
- Turbine motors, Governing methods used in—
 Cut-out jet, 443, 444, 452.
 Hand-regulated guide blade, 408, 409, 416, 417.
 ——— sluice gate, 400.
 ——— ring, 419, 420.
 Jet deflector, 453, 454.
 Telemotor-regulated guide blade, 422-430.
 ——— sluice ring, 410, 419, 432-442.
 Throttle, 431.
 Variable jet, 448-451.
- Turbine motors, Governors used for—
 Cassell, 453.
 Escher-Wyss hydraulic relay, 448.
 ——— pressure-oil relay, 413, 435.
 Friction relay, 455, 456.
 Ganz hydraulic relay, 427
 Gilkes hydraulic relay, 451 454.
 Hetts, 454.

Turbine motors, Governors used for—

- King ratchet relay, 457.
- float relay, 458.
- Lombard pressure-oil relay, 428, 458.
- Platt Iron Works pressure - oil relay, 424.
- Piccard ratchet relay, 440.
- Pitman hydraulic relay, 450.
- Watson-Laidlaw float, 452.
- Woodward, 454-456.

Turbine motors, Hydraulic—

- Escher-Wyss, 410-413, 434-437, 448.
- Fourneyron, 403, 437-442.
- Francis, 414-437.
- Ganz, 425-428.
- Gilkes, 408, 409, 451.
- Girard, 406, 441-445.
- Jonval, 406, 407.
- Lundale, 420.
- Morris Co., I. P., 429-432, 442.
- New American, 416, 417.
- Orten-Boving, 445, 446.
- Pelton, 403, 445-454.
- Piccard, 438-440.
- Platt Iron Works, 421-424.
- Samson-Leffel, 415.
- Theory of, 402-407, 418, 446, 447.
- Theodore Bell, 414, 443.
- Thomson, 403, 408, 409.
- Various types of, 402-407.
- Victor, 419-424.
- Victoria, 445, 446.

Turbine motors, Impellers used in—

- Conical-flow, 410.
- Diagonal-flow, 411-413.
- Inward-flow, 403, 408, 409.
- Mixed-flow, 414-437.
- Outward-flow, 403, 437-445.
- Parallel-flow, 406, 407.
- Radial-axial-flow, 414-437.
- Tangential-flow, 403, 406, 445-454.
- Vortex, 408-410.

Turbine motors, Installations of. 407, 411, 412, 415-419, 421-444.

Turbine motors, Speed control of—

- By centrifugal and hydraulic relay governor, 427, 448, 450, 451, 454.
- — and pressure-oil governor, 410, 412, 413, 428, 458.
- — and ratchet-relay governor, 415.
- hand regulation, 408, 416.

Turbine motors, with high-pressure head, 444-446, 448.

— — with low-pressure head, 407, 411, 416, 418.

— — with medium-pressure head, 421-433.

Turbine pumps—

- Allen, 397.
- Considerations for, 384, 398.
- Davey, 390.
- Early forms of, 373.
- Efficiency curves of, 392, 394, 396.
- Escher-Wyss, 395, 396.

Turbine pumps—

- Gwynne, 385, 386.
- Hayward-Tyler, 389.
- Laval, 380.
- Mather & Platt, 393, 394
- Multi-stage, 384-398.
- Orten-Boving, 398.
- Rees-Roturbo, 379.
- Self-regulating, 379.
- Single-stage, 373, 379-381.
- Stork, 381.
- Sulzer, 387, 388.
- Tests of, 385, 386.
- Theory of, 384.
- Victoria, 398.
- Worthington, 391, 392.

U

UNWIN, Prof., Report by, 28, 29, 41

V

VACUUM and condenser air pumps—

- Capacity of, 211.
- Combined dry and wet, 225, 226, 233.
- For jet condensers, 210, 212, 214, 217, 219, 234.
- For surface condensers, 213, 215, 217, 218.
- Double-acting, 220.
- Ejector, Kinetic, 232, 233.
- Piston or plunger—
 - Bodmer, 216, 217.
 - Borsig, 214.
 - Butler, 222-224.
 - Edwards, 215-217.
 - Fraser, 225.
 - Frikart, 217.
 - Heisler, 220.
 - Marine type, 213.
 - Stott, 219.
 - Three-valve, 210, 213, 226, 233.
 - Weir, 226.
 - With injection pump, 210.
 - Without foot valves, 215, 217-225.
 - foot or head valves, 222-224.
 - Worthington, 218.
 - Zylinderlast, 220.
- Piston or plunger, Combined dry and wet—
 - Advantages of, 225.
 - Fraser, 225.
 - Paxman, 225.
 - Weir, 226.
- Piston or plunger, Double-acting—
 - Frikart injection, 217.
 - Worthington injection, 212.
 - featherweight, 218.
- Piston or plunger, with cooled sealing water—
 - Advantages of, 226.
 - Weir "Dual," 226.

- Vacuum and condenser air pumps—
 Piston or plunger, Valveless—
 Double-stage vertical, 222.
 Single-stage vertical, 223.
 — inverted, 224.
 Rotary—
 Butler hydraulic ejector, 234.
 Connerville cycloidal, 228.
 Kinetic, 232, 233.
 Leblanc-Westinghouse, 229.
 Rees centrifugal, 230.
 Worthington hydraulic, 234.
- Vacuum from gas, First use of, for pumping, 5.
 — from gunpowder, First use of, for pumping, 5.
 — from steam, First use of, for pumping, 4, 5.
 — jet condensers, Water required by, 209.
 — surface condensers, Water required by, 210.
 — surface condensers, Air pump capacity for, 211.
- Valves, first used, 2.
- Valve gears for air pumps, 210, 219, 220, 221.
 — — for air-displacement pumps, 126, 256.
 — — for fire pumps, 273, 276.
 — — for gas-displacement pumps, 262.
 — — for hydraulic pumps, 237, 240.
 — — for hydraulic rams, 243, 244, 246.
 — — for high-speed pumps, 277-280, 282, 287, 288, 290, 291, 296.
 — — for Oddie-Barelay pump, 282-284.
 — — for pneumatic ejector, 251.
 — — for pulsator pumps, 72, 73, 249.
 — — for Riedler pumps, 280, 281.
 — — for Southwark pumps, 276-278.
 — — for variable-delivery pumps, 315.
- Valve gears used in steam pumping engines—
 Beam and float-controlled poppet, 6-8.
 Combined piston and slide, 172, 173.
 — Corliss and poppet, 33.
 Corliss-Craig, 28.
 Davey differential, 53-55.
 Piston and double-slide expansion, 29.
 Simpson-Corliss, 19.
 Slide, with balancing pendulums, 21.
 Watt-Cornish 3-valve, 9-11.
 Worthington-Corliss, 41-43.
- Valve gears, Steam, for direct-acting simplex pumps—
 With combined gear- and shuttle-operated piston valve, 150.
 With combined gear- and shuttle-operated slide valve, 140.
 With gear-operated pilot and shuttle-operated Corliss valve, 149.
 With gear-operated pilot and shuttle-operated piston valve, 155, 162.
 With gear-operated pilot and shuttle-operated slide valve, 141, 145, 159.
 With piston valve operated by shuttle controlled by main piston, 69, 164.
- Valve gears, Steam, for direct-acting simplex pumps—
 With slide valve operated by shuttle controlled by main piston, 146, 147, 158, 160.
 With gear-operated Corliss valve without shuttle control, 142.
 With gear-operated oscillating valve without shuttle control, 153.
 With gear-operated Corliss valve without shuttle control, 142.
- Valve gears, Steam, for duplex direct-acting pumps—
 With combined cross-over and direct-connected slide valves, 170.
 With cross-over connected piston valves, 172, 175.
 With cross-over connected slide valves, 166, 172, 174.
 With cross-over main-piston control, 167-169.
 With single valve having combined reciprocating and oscillating motion, 171.
- Valve gears, Hydraulic, for simplex direct-acting pumps—
 With gear-operated pilots and shuttle-operated piston valves, 238.
 With gear-operated pilots and shuttle-operated poppet valves, 237.
- Valve gears, for displacement pumps—
 Air-operated float distributor, 127, 251.
 For gas, 262.
 Hydraulic-operated, 256.
 Steam-operated float distributor, 253.
- Valves, Pump—
 Ball, 126, 165, 180.
 Beehive, 75.
 Butterfly, 63, 79.
 Conical composition, 287, 288.
 Disc, flat-seated, 39, 66, 77, 81, 179, 180, 254.
 — mitre-seated, 62, 65, 80, 162, 166, 174.
 Grid, diaphragm, 81, 210, 221, 249, 273.
 Hinged-flap, 76, 78, 79.
 Mechanically-actuated, 276-286.
 Pyramidal, 77, 78, 79, 243.
 Ring, 64, 75, 80, 96, 276.
 Spring coil, 76, 288, 291.
 Spherical, 144.
- Variable-delivery (constant-speed) plunger pumps—
 Valve gears for, 315.
 With compound eccentrics, 304, 312.
 With differential action, 304, 317, 318.
 With link, lost-motion action, 301.
 With radial cylinders, 306, 308, 321, 322.
 With variable-throw cranks, 304.
 — — eccentrics, 302, 310.
- Variable-delivery rotary pumps, 306, 308, 322, 340.
- Variable-transmission hydraulic motors—
 Radial, 306, 308, 321, 322, 341.
 Turbine, 324.

- Volute pumps—
 Early forms of, 372, 373.
 Impellers for, 359, 363, 364, 368, 371, 377.
 Theory of, 374-377.
 Vertical, 359, 360, 366.
 Vortex or whirl chamber, Efficiency of, 374-376.
 ———— First use of, 372.
 ———— Proportion of, 376.

W

- WAIHI MINES, New Zealand, Pumping engines for, 14.
 Wandsworth and Putney Gas Works, Air-lift pump for, 119.
 Water-falls, Combined power of, 2.
 Water, Necessity of, 1.
 ——— power, Extent of, 3, 401.
 ——— Properties of, 2, 430.
 ——— supply, Gas-power pumps for, 265, 266, 295, 298.
 ——— Hydraulic-power pumps for, 242-246.
 ——— Oil-power pumps for, 242-246.
 ——— Steam-power pumps for, 4-60, 95-120.
 ——— Wind-power pumps for, 352, 356.
 Water-wheel pumps, 235.
 Watt, James, Inventions of, 5, 7, 8.

- Watt, James, direct-acting pumping engine with closed cylinder, 8.
 ——— parallel motion, Engine with, 21.
 Waterworks, London's first, 235.
 Waterworks pumping engines—
 Direct-acting duplex class, 38-51.
 ——— simplex class, 52-60.
 Direct-displacement class, air, 254-257.
 ——— gas, 260-266.
 Rotary class, gas, 294-295.
 ——— high-speed, 277.
 ——— steam, 16-37.
 Water-wheels, 399, 400.
 West Middlesex Waterworks, Engines for, 40, 41.
 Widnes Waterworks, Engines for, 58.
 Wind-power pumps—
 Advantages of, 352.
 Limitations of, 352.
 Tests of, 353, 354.
 Uses of, 356.
 Woodeson-Corliss steam distribution, 148, 149.
 Worthington, Henry R., inventor of duplex pump, 38.
 ——— waterworks engines, 38-47.

Z

- ZWICKEY fire engine, 275.
 Zylinderlast air pump, 220.

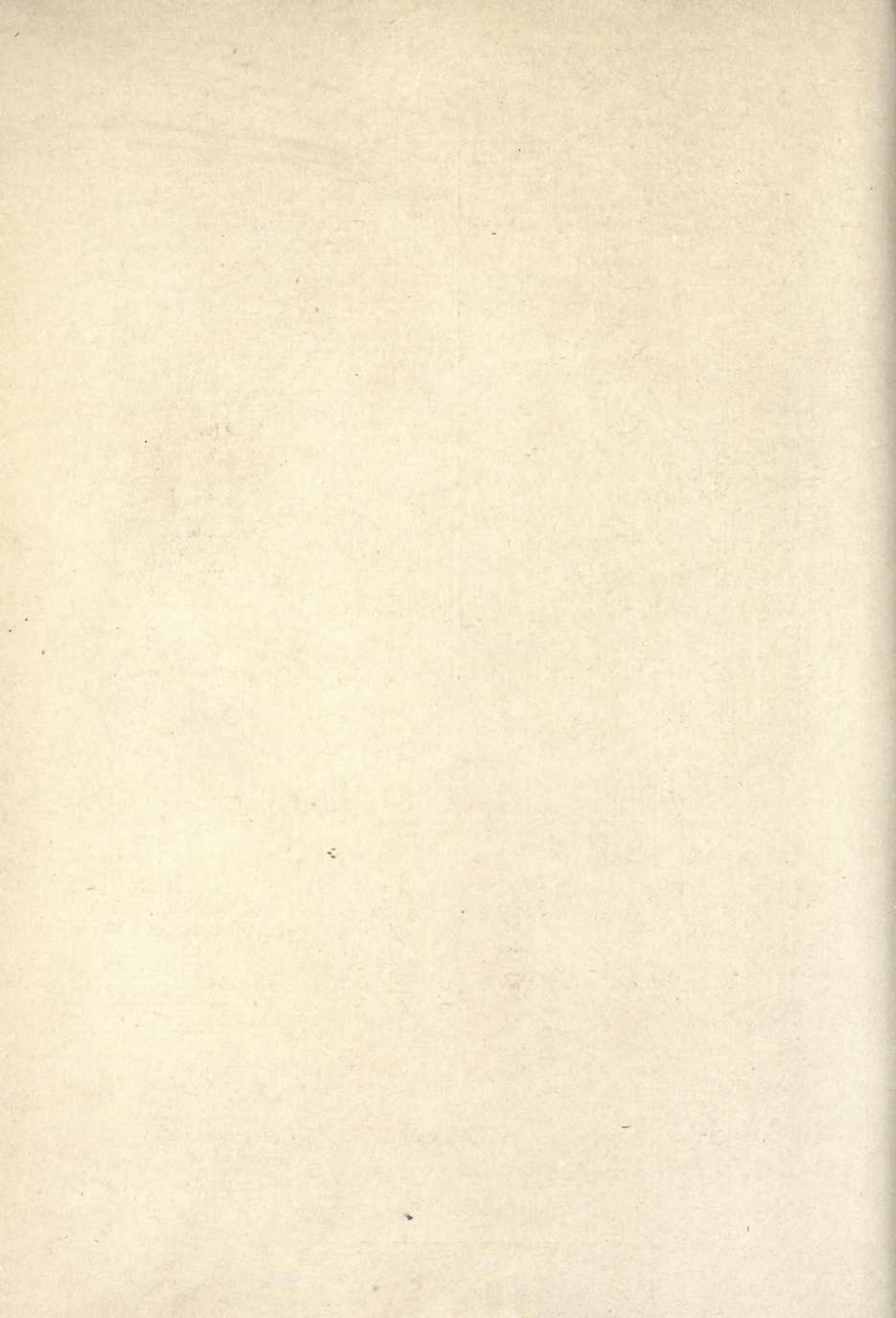

PUMPS

FOR HANDLING

SUGAR MASSECUITE, MOLASSES, SYRUP, SLUDGE,
SEWAGE EFFLUENT, OR OTHER VISCOUS MATERIAL.

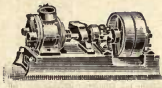

4120

ROTARY
MOLASSES PUMP.

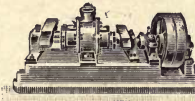

4121

DOUBLE-GEARED ROTARY
MOLASSES PUMP.

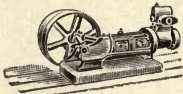

4123

BELT-DRIVEN HORIZONTAL
PLUNGER MOLASSES PUMP.

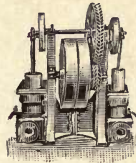

4119

GEARED VERTICAL PLUNGER
MOLASSES PUMP.

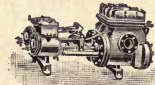

4122

STEAM-DRIVEN
MOLASSES PUMP.

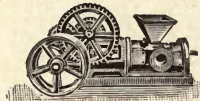

4118

BELT-DRIVEN
MASSECUITE PUMP.

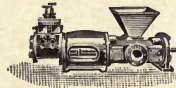

4117

STEAM-DRIVEN
MASSECUITE PUMP.

CENTRIFUGAL MACHINES

DRIVEN BY WATER.

FITTED WITH
PELTON WHEEL
AND
AUTOMATIC
CUT-OUT
APPARATUS.

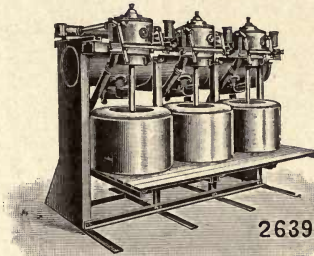

2639

CATALOGUES OF
PUMPS
AND
CENTRIFUGAL
MACHINES
ON APPLICATION.

WATSON, LAIDLAW & CO, LD,
98 DUNDAS STREET (SOUTH),
GLASGOW.

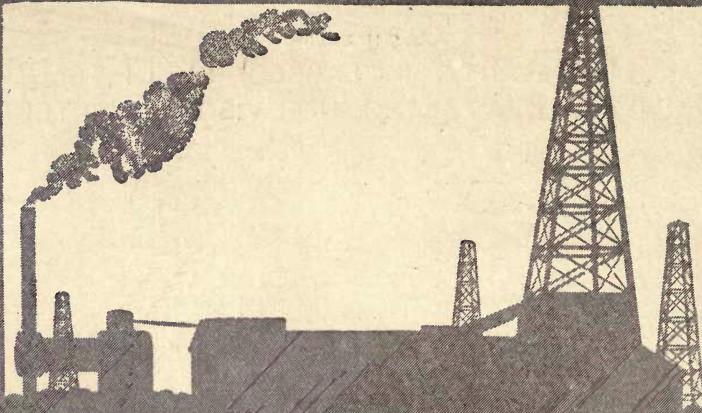

"OILWELL"

ESTD 1862.



TRADE MARK
(REGISTERED)

**EVERYTHING SUPPLIED TO DRILL AND
EQUIP OIL, GAS AND WATER WELLS.**

OILWELL SUPPLY Co.

EUROPEAN OFFICE—

DASHWOOD HOUSE, LONDON, E.C.2.

HEAD OFFICE—

PITTSBURGH, U.S.A.

“ OILWELL ”

Trade mark.

**PUMPING
MACHINERY**
FOR EVERY SERVICE IN THE
OIL-FIELDS.

**PIPE-LINE
SCHEMES**

Specifications prepared to meet
conditions in any part of the world.

OIL WELL SUPPLY Co.,

The Oldest and Largest Manufacturers,

DASHWOOD HOUSE,

LONDON, E.C. 2.

The Largest Range of Injectors, Ejectors, Etc. in the United Kingdom

FOR ALL CONDITIONS AND DUTIES.

Below are shown a few of the many Types made.

Fig. 4.

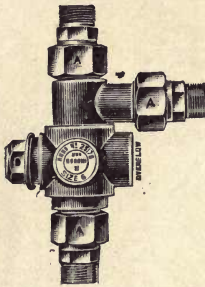

WHITE PATTERNS.

Fig. 7.

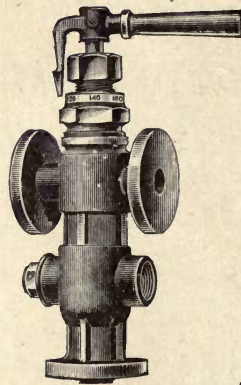

Fig. 10.

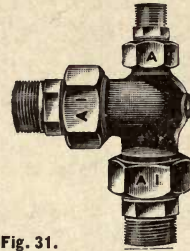

Fig. 25.

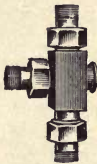

Fig. 29.



GRESHAM TYPES.

Fig. 31.

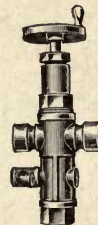

Fig. 30.



HALL TYPES.

Fig. 60.

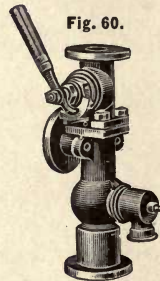

Fig. 55.

PENBERTHY TYPE.

Fig. 59.



PENBERTHY
TYPE.

SCHAFFER TYPE.

Catalogues on application to



PENDLETON, MANCHESTER.

LONDON OFFICE:

38 Victoria Street, Westminster, S.W.1.

Telephone No.—Victoria 6653.

Telegrams—"Powplants, Vic, London."

On Admiralty, War, Indian, and Colonial Office Lists.

EFFICIENCY



RELIABILITY

REES ROTURBO PATENT REVOLVING PRESSURE CHAMBER TURBINE PUMPS

THE distinguishing feature of the REES ROTURBO Pump is in the construction of the impeller, which is made in the form of a large capacity drum or Pressure Chamber, instead of the ordinary flat disc runner or impeller.

□
**SELF-REGULATION
WITH HIGHEST
EFFICIENCY.**

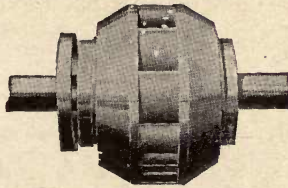

□
**SELF-REGULATION
WITHOUT
CHOKING.**

REES ROTURBO IMPELLER
OR REVOLVING PRESSURE DRUM.

In the rim of the drum are a series of turbine nozzles pointing in a rearward direction. By this design universal self-regulation is secured. If the head is reduced below the normal the turbine nozzles extract the energy of the increased speed of water through the drum and convert into torque this energy, which would otherwise be wasted and would expend itself on wear on the metal surfaces. In addition to this, the resultant velocities are low; the total energy generated by centrifugal force leaving the impeller at 75% pressure and only 25% velocity. Wear and tear is thus reduced to the minimum.

Illustrated Pamphlet, giving a full description of REES ROTURBO Pumps, on application.

Quote R 191—Z.

The REES ROTURBO Manufacturing Co., Ltd.,

Hydraulic, Electrical, and General Engineers,

HEAD OFFICE AND WORKS—**WOLVERHAMPTON, England.**

CAIRD & RAYNER, LIMEHOUSE, E. 14.

SPECIALISTS in the Manufacture of

Fresh Water Distilling Plants—Land or Marine.
Boiler Feed and Service Pumps.
Evaporators—using Live or Exhaust Steam.
Feed Water Heaters.
Feed Water Filters.
Water Heaters and Storage Calorifiers—automatically controlled.
Plate Washing Machines.

ON ADMIRALTY, WAR OFFICE, AND CROWN AGENTS' LISTS.

Telegrams—VAPORIZE, LONDON.

Telephone—EAST 210.

CHARLES GRIFFIN & CO., LTD., PUBLISHERS.

NINTH EDITION. Folio, Strongly bound. 15s., postage extra.

TRAVERSE TABLES:

Computed to Four Places of Decimals for every Minute of Angle
up to 100 of Distance.

For the use of Surveyors and Engineers.

By RICHARD LLOYD GURDEN,

Late Surveyor for the Governments of New South Wales and Victoria.

* * * *Published with the Concurrence of the Surveyors-General for New South Wales and Victoria.*

"Those who have experience in exact SURVEY-WORK will best know how to appreciate the enormous amount of labour represented by this valuable book. Every Surveyor in active practice has felt the want of such assistance, FEW KNOWING OF THEIR (the Tables) PUBLICATION WILL REMAIN WITHOUT THEM."—*Engineer.*

In 4to, Boards. 7s. 6d., postage extra.

MEASUREMENT CONVERSIONS (English and French):

43 GRAPHIC TABLES OR DIAGRAMS, ON 28 PLATES.

Showing at a glance the MUTUAL CONVERSION OF MEASUREMENTS in
DIFFERENT UNITS

Of Lengths, Areas, Volumes, Weights, Stresses, Densities, Quantities
of Work, Horse Powers, Temperatures, &c.

For the use of Engineers, Surveyors, Architects, and Contractors.

By PROF. ROBERT H. SMITH, A.M. INST. C.E., M.I. MECH. E., &c.

LONDON: CHARLES GRIFFIN & CO., Ltd., EXETER ST., STRAND, W.C. 2.



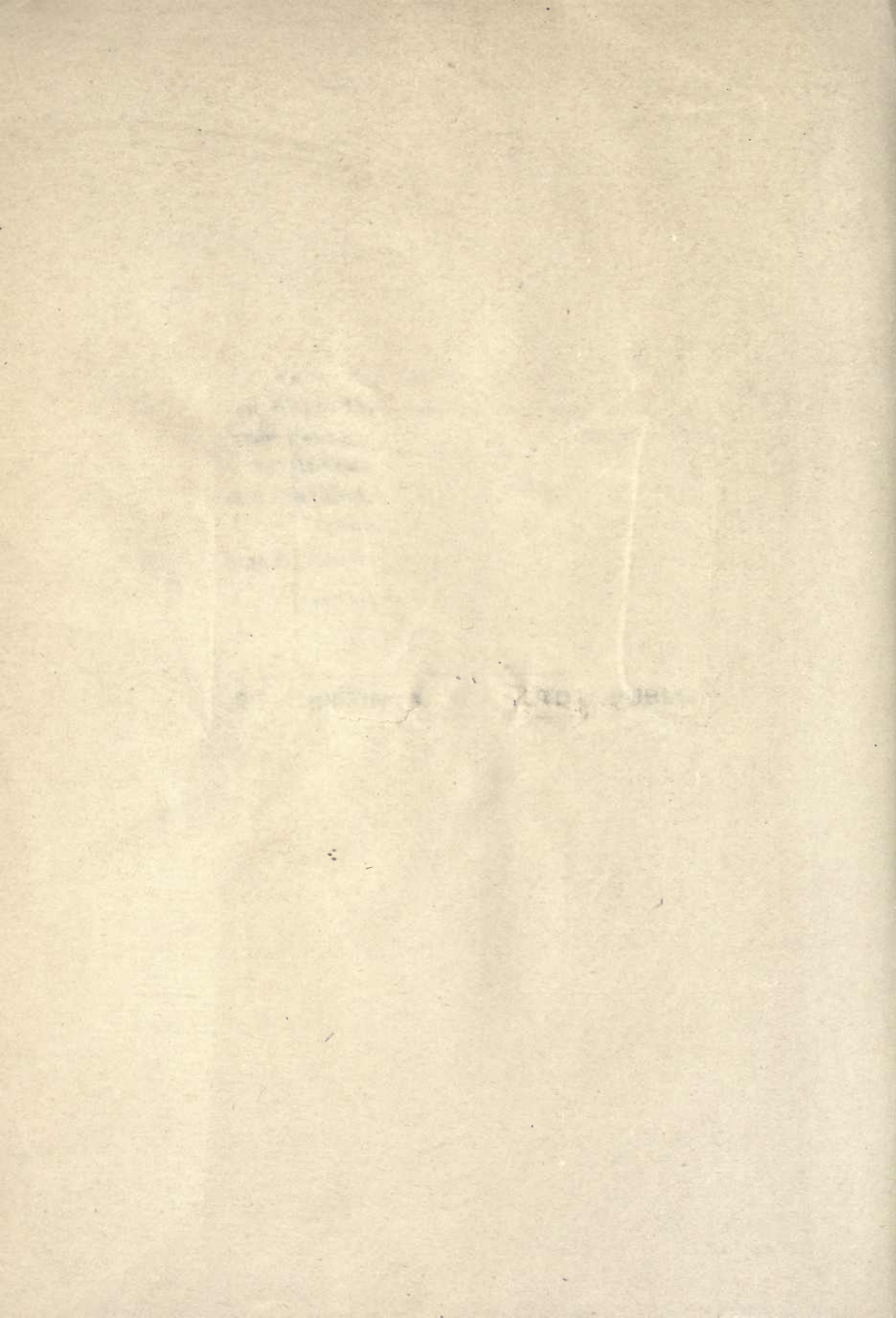

THIS BOOK IS DUE ON THE LAST DATE
STAMPED BELOW

AN INITIAL FINE OF 25 CENTS
WILL BE ASSESSED FOR FAILURE TO RETURN
THIS BOOK ON THE DATE DUE. THE PENALTY
INCREASE TO 50 CENTS ON THE FOURTH
DAY AND TO \$1.00 ON THE SEVENTH DAY

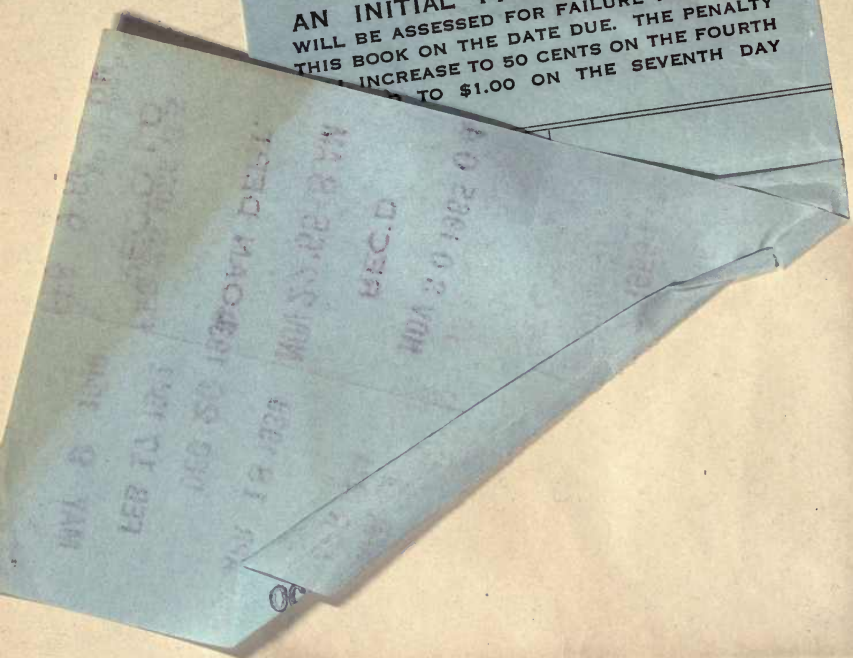

M I E 2

1
1
1

500995

TJ
900
B8
1922

UNIVERSITY OF CALIFORNIA LIBRARY

