

MECHANISM OF STEAM ENGINES



BY

WALTER H. ^{*erman*}JAMES, S. B.

ASSISTANT PROFESSOR IN THE DEPARTMENT OF MECHANICAL ENGINEERING
MASSACHUSETTS INSTITUTE OF TECHNOLOGY

AND

MYRON W. DOLE, S. B.

INSTRUCTOR IN MECHANICAL ENGINEERING
MASSACHUSETTS INSTITUTE OF TECHNOLOGY

FIRST EDITION

FIRST THOUSAND

NEW YORK
JOHN WILEY & SONS, Inc.
LONDON: CHAPMAN & HALL, LIMITED

1914



COPYRIGHT, 1914,

BY

WALTER H. JAMES AND MYRON W. DOLE

Stanbope Press

F. H. GILSON COMPANY
BOSTON, U.S.A.

PREFACE

THIS book is intended as an elementary treatise on the kinematics of reciprocating steam engines and steam turbines. Sufficient attention is given to the behavior of the steam itself to enable the student to study intelligently the machine for which the steam is the source of power. The indicator card, or pressure-volume diagram, is employed in this connection. No consideration is given to the underlying heat theory or to the details of construction of the various parts of the machines.

The book has been planned primarily to meet the needs of students who take up this subject as a part of, or immediately following, their course in the elements of mechanism, before they study the theory and practice of heat engineering or machine design.

The purpose of the authors has been to present the subject in such a way as to make clear to the beginner the mechanical principles on which the steam engine operates, with special reference to the valve gear and governing devices, and the various diagrams used for studying the same. Examples are given of the different types of mechanisms, these examples being chosen merely to illustrate principles and methods, without particular reference to their relative importance.

In dealing with a subject which has been so thoroughly developed as has the steam engine, it would be useless to claim that any new principles are set forth in an elementary textbook such as the present one. The aim is to treat the subject in a logical manner, as concisely as possible, yet with sufficiently detailed explanations to make the principles easily understood.

Chapter X describes the principle of action of steam turbines in general and explains briefly the various types of turbines, giving an example of each.

Chapter XI treats of the method of controlling the steam supply to turbines and describes two mechanisms which are used for this purpose.

Thanks are due to the various builders of engines and turbines for their ready response to requests for information, for the loan of cuts, and for permission to make free use of the material contained in their publications. Acknowledgment is also made of the assistance rendered by the authors' associates at the Massachusetts Institute of Technology.

W. H. J.
M. W. D.

BOSTON, MASS. *October, 1914.*

CONTENTS

	PAGE
INTRODUCTION.....	vii
CHAPTER I	
GENERAL DISCUSSION OF A RECIPROCATING STEAM ENGINE.....	I
CHAPTER II	
SINGLE-VALVE ENGINES.....	25
CHAPTER III	
VALVE DIAGRAMS.....	39
CHAPTER IV	
TYPICAL PROBLEMS ON THE SLIDE-VALVE ENGINE.....	48
CHAPTER V	
GOVERNING DEVICES FOR SINGLE-VALVE ENGINES.....	63
CHAPTER VI	
RIDING CUT-OFF VALVES AND THEIR GOVERNING DEVICES.....	78
CHAPTER VII	
MULTIPLE-VALVE ENGINES.....	95
CHAPTER VIII	
HAND-OPERATED REVERSING AND CONTROLLING GEARS.....	111
CHAPTER IX	
VALVE SETTING.....	128
CHAPTER X	
STEAM TURBINES.....	138
CHAPTER XI	
TURBINE VALVE MECHANISMS AND GOVERNORS.....	156

INTRODUCTION

THE steam engine is a machine by means of which steam is enabled to do mechanical work. The steam ends of direct-acting steam pumps, steam drills, steam hammers, and the like are essentially steam engines adapted to some particular work. The various tools operated by compressed air, such as drills, riveters, pneumatic hoists, and air brakes, belong to the same general class of machines, the main difference being that the working fluid is air instead of steam. All are machines by means of which a compressible fluid does work by virtue of a change in the internal condition of the fluid.

A machine such as an air compressor is the reverse of the engine in that it works upon a compressible fluid and puts it in a condition in which it is able to do work. A pump which pumps water or other liquid is, like the compressor, a machine for doing work on a fluid but differs from the compressor in that the fluid upon which it works is practically incompressible and the pump merely changes the position of the fluid without producing any appreciable change in its internal condition.

In the design of any one of these machines four elements must be considered. First, the properties of the vapor, gas, or liquid with which the machine works; second, the kinematics of the machine itself, that is, the geometry of the machine; third, the dynamics of the machine, that is, the transmission of forces through the parts of the machine; fourth, the details of construction of the parts so that they shall be strong enough and be practical to make and use. These four elements are, of course, closely related to each other and it is impossible to study one without some reference to the others.

In the present treatise we are to deal principally with the kinematics of some of the machines already referred to, touching upon the other sides of the question only so far as is necessary in order to deal with the subject in a logical and intelligent manner.

Since the steam engine is the most common and important of these machines, and the principles involved are broader, we shall consider that

first and considerably more in detail than the other machines which follow.

Steam engines may be divided into two general classes:

1. Those, known as reciprocating engines, in which the steam imparts a reciprocating motion to a piston, and this motion by means of a suitable mechanism causes rotation of a shaft or else is carried directly from the piston to the point where the work is done.
2. Those in which the steam imparts rotation to a shaft directly without the intervention of a reciprocating piston.

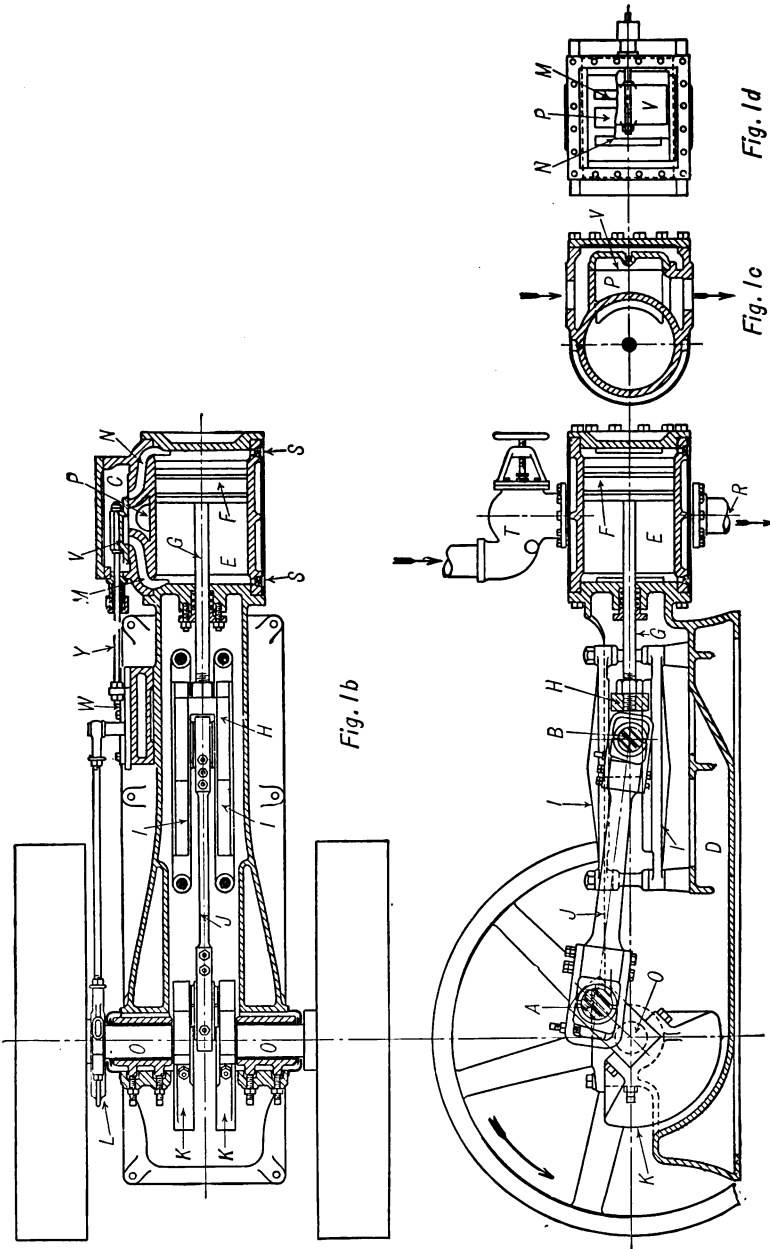

Fig. 1. Simple Steam Engine.

MECHANISM OF STEAM ENGINES

CHAPTER I

GENERAL DISCUSSION OF A RECIPROCATING STEAM ENGINE

1. There are a great many types of reciprocating steam engines, differing widely in size and general design. Certain fundamental principles of design and method of action are common to all however. The parts of a reciprocating engine may be divided into three main groups:

1. Stationary parts (frame, cylinder, bearings).
2. Piston, piston rod, crosshead, connecting rod, crank, shaft, and flywheel, to which the steam imparts motion.
3. Valve mechanism, which controls the supply of steam.

The most direct way to gain familiarity with the parts and with the principles of operation is to study in detail a simple example.

2. Description of a Simple Engine. Fig. 1 represents a small reciprocating engine of the type known as a plain-slide-valve engine. Directly on the concrete or masonry foundation rests the frame *D*, carrying, in suitable bearings near one end, the engine shaft *O*, while bolted to it at the other end is the cylinder *E*. The cylinder is closed at the ends by heads, and is covered, or lagged, with some material which is a good non-conductor of heat, to prevent too rapid radiation. In the cylinder is the piston *F*, which moves from one end to the other under the influence of steam pressure. There must be no leakage of steam past the piston, and it is made steam tight by two split rings in grooves around the piston, which spring outward and press against the cylinder walls. The piston is rigidly attached to the piston rod *G*, the latter being attached at the other end to the crosshead *H*. Where the piston rod passes through the cylinder head leakage of steam is prevented by packing. The crosshead slides back and forth between the guides *I*, which prevent any tendency to bend the piston rod.

The motion of the crosshead is carried to the crank pin *A* by means of the connecting rod *J*, the latter being attached to the crosshead by the wrist pin or crosshead pin *B*. The connecting rod is provided with boxes of suitable bearing metal, and provision is made for taking up wear. In this particular engine the shaft *O*, crank, and crank pin are forged in one piece, called a crank shaft. The weight of the crank and crank pin and part of the weight of the connecting rod are balanced by the counterweights *K*, which latter are bolted to the crank. The shaft in this case carries two heavy flywheels, which serve to make the engine run steadily and provide a means of taking off power by belts. The eccentric *L* is fast to the shaft and is connected by the eccentric strap and eccentric rod to the valve stem guide *W* which in turn is connected to the valve *V* by the valve stem *Y*. The valve has a reciprocating motion on suitable guides, in a steam-tight box *C*, known as a steam chest, or valve chest, which is cast on the side of the cylinder. This valve controls the flow of steam to and from the cylinder. The vertical surface, against which the valve runs, and which is called the valve seat, has in it three openings *M*, *N*, and *P* called *ports*; *M* and *N* open into the cylinder near the ends while *P* connects to the exhaust pipe *R*. The metal left between the ports forms the *bridges*. These ports and bridges are shown in Fig. 1 b and Fig. 1 d.

3. Fundamental Definitions. The end of the cylinder which is nearer the crank is usually spoken of as the *crank end* while the opposite end is called the *head end*. The port *M* is called the crank-end steam port while *N* is called the head-end steam port; *P* is called the exhaust port. When the crank and connecting rod are in line, the crank being toward the cylinder and the piston at the head end, the engine is said to be on the head end dead point or dead center. After the crank has turned 180° so that the piston is at the crank end of the cylinder the engine is said to be on the crank end dead point or dead center. The motion of the piston from the head end of the cylinder to the crank end is called the forward stroke, while the motion from the crank end back to the head end is called the return stroke.

4. Action of the Engine. Referring to Fig. 1 a, steam from the boiler enters the steam chest through the throttle valve *T*, surrounds the valve and enters port *N* as soon as the valve uncovers it, thus admitting steam on the head-end side of the piston. At the same time steam which has already done its work on the crank-end side of the piston may flow out through the port *M*, into the exhaust cavity of the valve, around the

bridge and into the exhaust port P . Fig. 1 c, which is a section through cylinder, steam chest and valve, will help to make clearer how the steam enters and leaves the steam chest. The difference of pressure on the two sides of the piston drives it toward the crank end of the cylinder and its motion is transmitted through the piston rod, crosshead and connecting rod to the crank pin, thus causing the shaft to turn. At the proper time the valve moves so as to stop the flow of steam into the head end, then connects the head end with the exhaust, and finally moves far enough to admit steam through port M into the crank end, thus driving the piston back to the head end. This, in brief, is the way that steam under pressure causes a piston to have a reciprocating motion which, in turn, is transformed into a continuous rotation of the shaft.

The opening of the port to admit steam to the cylinder is called *admission*, cutting off the supply by closing the port is called *cut-off*, the opening of the exhaust for spent steam is called *release* and the closing of the exhaust is called *compression*. These are the four *events of the stroke* and will be discussed in detail later.

For each end of the cylinder the events occur in this order: admission, cut-off, release and compression, and they will be designated by the letters A , C , R and K , respectively, while subscripts (h) and (c) will indicate to which end the event belongs; thus, A_h indicates admission on the head end while K_c indicates compression on the crank end. The abbreviations H.E. and C.E. may be used to indicate head end and crank end respectively.

It is important to know approximately where the crank is when each of these events occurs and what is taking place in the cylinder in the intervening time. This is indicated in Fig. 2 for the head end, and a similar diagram might be drawn for the crank end, the direction of rotation being as shown by the arrow. Head-end admission usually occurs just before the crank reaches the head-end dead point, when the crank is about at A_h ; steam flows into the cylinder until the crank reaches some such position as C_h , when cut-off occurs. The position of C_h depends upon the way the eccentric and valve are set, this setting, in turn, depending partly upon the amount of work the engine is doing. After cut-off the port is closed for a time, and the steam confined in the cylinder forces the piston along by expanding. When the crank pin reaches R_h the valve will have moved so as to begin to uncover the port on the exhaust side and allow the spent steam to begin to flow out. It continues to flow out until the crank pin reaches K_h , when the port will

close for exhaust and the steam remaining in the cylinder is compressed ahead of the piston, thus serving to check the momentum of the

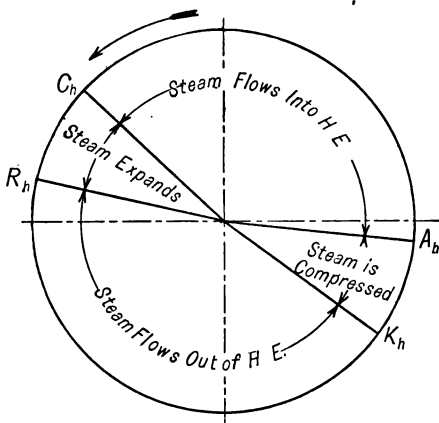

FIG. 2.

reciprocating parts, preparatory to the reversal of direction of piston movement, which occurs when the crank reaches the dead point.

Piston, Crosshead, Connecting Rod and Crank

5. From the preceding description it is evident that the reciprocating motion of the piston is transferred by the piston rod to the crosshead, and is transformed into rotary motion of the shaft by the connecting rod and crank. It is important to get clearly in mind the action of these parts and the effect of the connecting rod on the motion of the crosshead and therefore of the piston if, under the steadying action of the flywheel, the shaft turns with uniform angular speed. Since the motion of crosshead and piston are the same we will refer to the motion of the crosshead pin as the motion of the piston.

6. **Displacement of Crosshead.** In referring to the piston position at any time it is customary to describe its position by stating the linear displacement of the crosshead from either one of the extremes. This displacement is commonly given in percentage of the length of the stroke. For example, if a certain event occurs when the piston is moving toward the crank end and has moved three quarters of the distance from the head end to the crank end that event is said to occur at 75 per cent of the forward stroke. The crosshead displacement for any given crank angle, or the crank angle for any given crosshead position, may be found

graphically or may be calculated. For ordinary work the graphical method is convenient and sufficiently accurate. It is well, however, to be familiar also with the analytical method and we will accordingly consider both.

In Fig. 3 the crank and connecting rod are shown diagrammatically. When the crank pin is at A_1 the center of the crosshead pin is at B_1 , on the head-end dead point. When the crank has turned to any position OA the center of the crosshead pin is at B , found by cutting the path of the crosshead pin with an arc whose center is A and whose radius is the length of the connecting rod (from center of crank pin to center of crosshead pin). The piston displacement from the head-end extreme position is

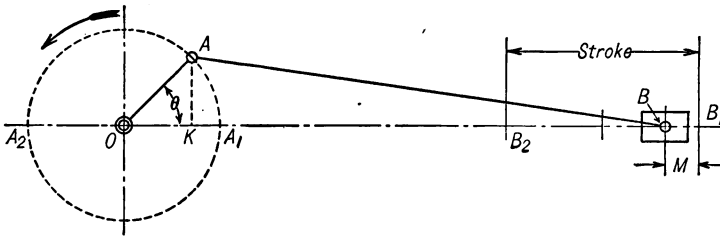

FIG. 3.

therefore M . If this construction is drawn accurately to scale the distance M can be measured off accurately. If M is desired in percentage of the stroke it is only necessary to divide M by the length of the stroke. If the crank is drawn at a suitable scale the distance M can be measured off directly in percentage of the stroke. For example, if OA is made $2\frac{1}{2}''$ on the drawing the stroke will measure $5''$ or $\frac{1}{2} \frac{0}{0}''$. Accordingly $\frac{1}{2} \frac{1}{0}''$ is one per cent. Therefore, if M is $\frac{8}{2} \frac{0}{0}''$ it will be 8 per cent of the stroke. Similarly if $OA = 1\frac{9}{16}''$, $\frac{1}{32}''$ is one per cent or if $OA = 3\frac{1}{8}''$, $\frac{1}{16}''$ is one per cent. It is advisable, when possible, to draw the crank and connecting rod at one of the above scales or at some similar scale so that some convenient fraction of an inch is $\frac{1}{100}$ of the stroke.

If the crosshead displacement is known the corresponding crank position may be found by locating the center of the crosshead pin and from this point, with a radius equal to the length of the connecting rod, cutting the crank pin circle.

The equation for calculating the displacement M when the crank position is known, or for calculating the angle θ which the crank makes

with the center line when the crosshead displacement M is known, may be derived as follows:

$$M = OB_1 - OB, \text{ where } OB_1 = OA + AB.$$

Now drop a perpendicular from A to the center line.

$$\text{Then } OB = OK + KB.$$

From triangle OAK

$$OK = OA \cos \theta.$$

From triangle KAB

$$\begin{aligned} KB &= \sqrt{AB^2 - KA^2} \\ &= \sqrt{AB^2 - OA^2 \sin^2 \theta}. \end{aligned}$$

Therefore

$$OB = OA \cos \theta + \sqrt{AB^2 - OA^2 \sin^2 \theta},$$

and

$$\begin{aligned} M &= OA + AB - OA \cos \theta - \sqrt{AB^2 - OA^2 \sin^2 \theta} \\ &= OA (1 - \cos \theta) + AB \left[1 - \sqrt{1 - \frac{OA^2}{AB^2} \sin^2 \theta} \right]. \end{aligned} \quad (1)$$

C is often used to represent the length of the crank and L to represent the length of the connecting rod, $\frac{L}{C}$ being, therefore, the ratio of the connecting rod to the crank.

7. Velocity of Crosshead. Assuming that the crank turns with uniform angular speed the speed of the crank pin is uniform and is expressed by the equation

$$S = 2\pi CN,$$

where S is the speed of crank pin in linear units per unit of time, C the length of the crank (in the same linear units) and N the number of revolutions of the crank in the unit time. N is commonly expressed in revolutions per minute (R.P.M.) and C in feet, therefore S will be in feet per minute. The speed of the crosshead will vary from zero at the dead points to a maximum at some point between. The speed of the crosshead for any given crank position may be found graphically from the speed of the crank pin by any one of several constructions, one of which is shown in Fig. 4.

It can be proved that

$$\frac{\text{Speed of crosshead}}{\text{Speed of crank pin}} = \frac{Om}{OA},$$

where m is the point where the center line of the connecting rod cuts the line through O , perpendicular to the center line of crosshead pin motion.



FIG. 4.

For a known speed of the crank pin the crosshead speed may be found as follows:

On the crank lay off Od to represent the speed of the crank pin. Through d draw a line parallel to AB cutting at e the line through O , perpendicular to the line of the crosshead motion. Then Oe represents the speed of B . The following equation expresses the ratio of the speed of the crosshead to the speed of the crank pin for any given crank angle θ .

$$\frac{\text{Speed crosshead}}{\text{Speed crank pin}} = \sin \theta + \frac{C \sin \theta \cos \theta}{\sqrt{L^2 - C^2 \sin^2 \theta}}, \quad (2)$$

where C represents the length of the crank and L the length of the connecting rod.

The proof of the above equation as well as of the preceding graphical construction depends upon the ordinary principles of mechanism and need not be given here.

8. Harmonic Motion. If the crank pin worked in a slot in the crosshead, as in Fig. 5, instead of being connected to the crosshead by a connecting rod,

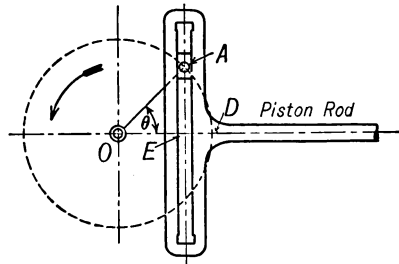

FIG. 5.

the cross head would have what is known as harmonic motion if the crank turned uniformly. The displacement for any crank angle θ is DE where E is the foot of a perpendicular from the center of

the crank pin to the center line of the crosshead path. The equation for the value of this displacement is

$$DE = OD - OE = OA (1 - \cos \theta). \quad (3)$$

The extent to which the motion of the crosshead with a connecting rod varies from harmonic motion depends upon the length of the connecting rod relative to the crank. If the crosshead in Fig. 3 had harmonic motion its displacement for the crank angle there shown would be A_1K . Its actual displacement is B_1B which, if the drawing were at a large enough scale, would be noticeably different from A_1K . This variation may be seen by comparing equations (1) and (3).

From (1)

$$\text{Displacement} = OA (1 - \cos \theta) + AB \left[1 - \sqrt{1 - \frac{OA^2}{AB^2} \sin^2 \theta} \right].$$

From (3)

$$\text{Displacement} = OA (1 - \cos \theta).$$

Evidently then the displacement of the crosshead with a connecting rod varies from harmonic motion by the quantity

$$AB \left[1 - \sqrt{1 - \frac{OA^2}{AB^2} \sin^2 \theta} \right],$$

where OA is the length of the crank and AB the length of the connecting rod. As the connecting rod is increased in length the value of this

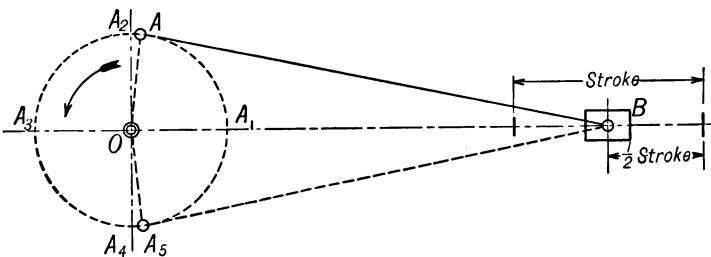

FIG. 6.

quantity becomes less and the motion of the crosshead becomes more nearly harmonic. In practice the ratio of connecting rod to crank varies from 4 to 8.

One position in which this variation is especially noticeable is the mid-position of the crosshead, that is the half stroke position. In Fig. 6 the

crosshead pin B is in the middle of its stroke and with the connecting rod AB the crank pin is either at A or A_5 according as the piston is on its forward or return stroke. If the motion were *harmonic* the crank pin would be at A_2 or A_4 when the crosshead is in the middle of its stroke. The shorter the connecting rod relative to the crank, the greater will be the angles AOA_2 and A_5OA_4 . In any case $AOA_2 = A_5OA_4$.

Valve, Eccentric Rod and Eccentric

9. The valve, valve stem guide, eccentric rod and eccentric constitute essentially the same kind of a mechanism as the piston, crosshead connecting rod and crank; therefore the same methods may be used for determining displacements and velocities. There are certain special features about the eccentric mechanism, however, which need to be mentioned.

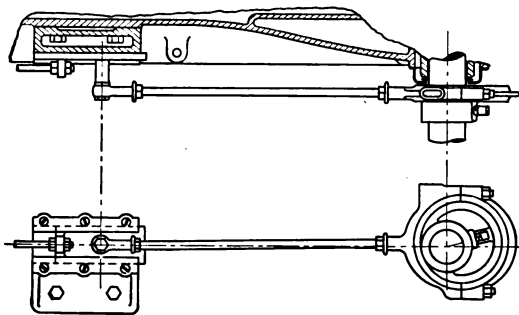

FIG. 7.

Fig. 7 is a drawing of the valve mechanism for the engine shown in Fig. 1 and the names of the parts have already been given.

Fig. 8 is a diagram of an eccentric, eccentric rod and valve stem guide mechanism. The eccentric itself is a circular disk keyed to the shaft. E is the center of the eccentric and O is the center of the shaft. The eccentric is really a crank pin large enough to include the shaft. The distance OE is known as the *eccentricity* and corresponds to the distance from the center of the shaft to the center of the crank pin on a crank of the ordinary kind. In our diagrams we will usually represent the eccentric by the center line of the equivalent crank. When E is in the position E_1 the center D of the pin which attaches the eccentric rod to the valve stem is at one end of its travel and when E is at E_2 , D is at the other end of its travel. The total travel of the valve therefore, when

connected directly to the eccentric rod as in this case, is twice the eccentricity.

10. Mid-position. The term mid-position is one which occurs frequently in discussing valve movements and an explanation of the meaning of the term is desirable. In general the valve is said to be in mid-position when it is halfway between the two extreme positions of its motion. With certain special types of valves which will be considered later the so-called mid-position may be chosen in some other place.

11. The position of the valve is usually described by stating its displacement from mid-position instead of from one extreme, as was the case with the piston. For example, in Fig. 8, since the valve displacement is, of course, equal to the displacement of the point D , the valve would be said to be displaced a distance N toward the head end. If

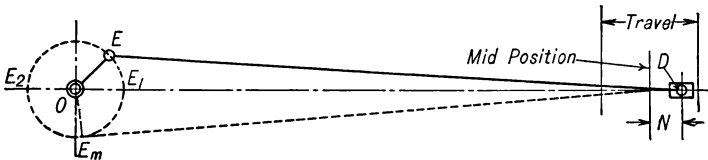

FIG. 8.

this displacement were to be calculated an equation similar to equation (1) would be used which would give the displacement from one end of the stroke of D ; then the difference between that calculated distance and one half of the stroke would give the displacement of D from mid-position.

As a rule the eccentric rod is long relative to the eccentricity so that the motion of a direct-connected valve, such as we have been discussing, is approximately harmonic. This appears in Fig. 8 where the eccentric center line OE_m is nearly vertical when D is in mid-position.

12. Rockers. It happens very frequently that the construction of an engine is such that the valve rod cannot be directly connected to the eccentric rod. It then becomes necessary to interpose some device to transfer the motion from one line to another, in the same plane, or frequently from one line to another in different planes. Figs. 9, 10 and 11 show a common device for this purpose, known under the general name of rocker. In Fig. 9 the axis or fulcrum is at A , the eccentric rod attaches at B and the valve stem at C . Since B and C are on the same side of the pivot the direction of motion of the valve stem is not changed by the rocker. The total travel of the valve is practically equal to the

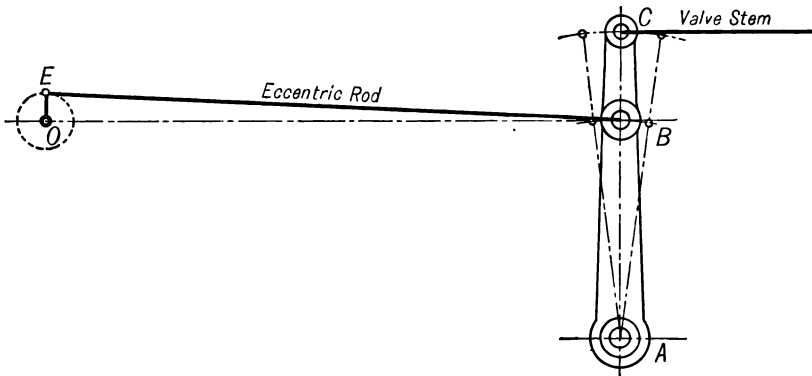

FIG. 9.

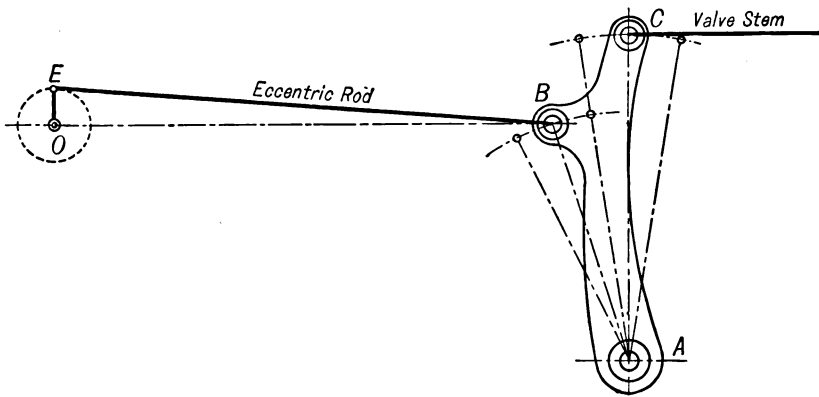

FIG. 10.

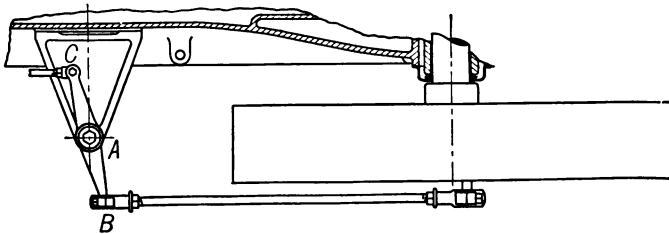

FIG. 11.

eccentricity multiplied by $\frac{AC}{AB}$. In Fig. 10 the same general type of rocker is shown but here the arms AB and AC do not coincide so that the valve travel is not necessarily equal to the eccentricity multiplied by the ratio of the arms. Rockers of the kind shown in these two figures are sometimes called bell crank levers. The term carrier is also sometimes applied to them.

In Fig. 11 is shown a rocker in which the pivot is between the points of attachment of the eccentric rod and valve stem. The points B and C are evidently at all times moving in opposite directions. Rockers of this type may be made with the arms 180° apart or at some less angle. If the angle is 180° the valve travel is practically equal to the eccentricity multiplied by the ratio of the arms, while with an angle other than 180° this is not necessarily true. For convenience we will refer to rockers of the style shown in Figs. 9 and 10 as non-reversing rockers, and those in which the pivot is between the eccentric rod pin and valve-stem pin as reversing rockers.

The arms of any rocker may lie in the same or in different planes.

The methods for designing rockers and for setting the eccentric to give proper motion to the valve when driving through the various kinds of rockers will be referred to later.

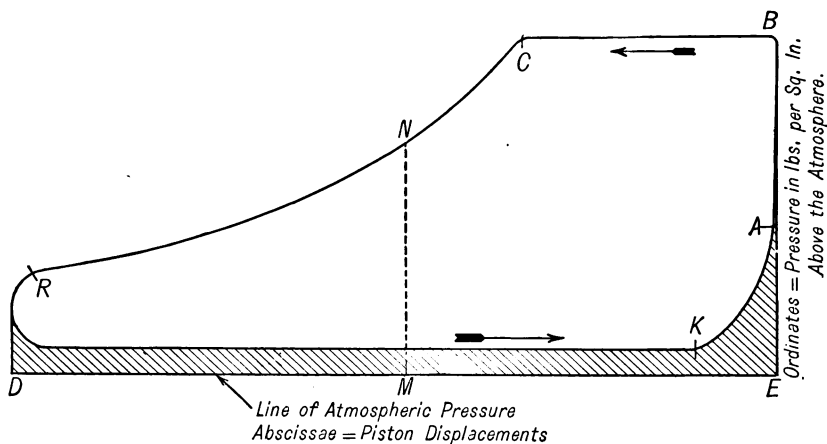

FIG. 12.

13. Indicator Diagrams. In studying the action of a steam engine, particularly as related to the design and adjustment of the valve gear, it is convenient to have some sort of a diagram which shall show how the steam is distributed during a revolution.

The conditions within the cylinder may be represented by a diagram, such as that shown in Fig. 12. The abscissæ are piston displacements, at some known scale, and the ordinates are corresponding pressures in the cylinder measured in pounds per square inch and plotted at a convenient scale. In Fig. 12, 1 inch represents 60 pounds pressure per square inch, and a distance of 4 inches represents the length of the stroke.

In practice the engine is made to draw its own diagram by means of the device shown in Figs. 13 and 14, known as an engine indicator.

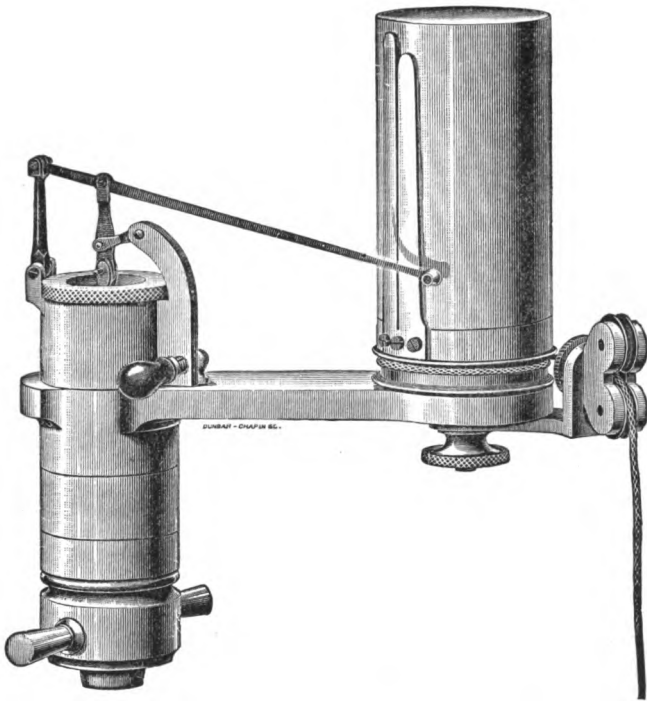

FIG. 13. Crosby Steam Engine Indicator.

These figures and the following description taken from a book published by the Crosby Steam Gage and Valve Company will explain the action of the indicator.

“A piston of carefully determined area is nicely fitted into a cylinder so that it will move up and down without sensible friction. The cylinder is open at the bottom and fitted so that it may be attached to the cylinder of a steam engine and have free communication with its interior, by

which arrangement the under side of the piston is subjected to the varying pressure of the steam acting therein. The upward movement of the piston — due to the pressure of the steam — is resisted by a spiral spring of known resilience. A piston rod projects upward through the cylinder cap and moves a lever having at its free end a pencil point, whose vertical movement bears a constant ratio to that of the piston. A drum of cylindrical form and covered with paper is attached to the cylinder in such a manner that the pencil point may be brought in con-

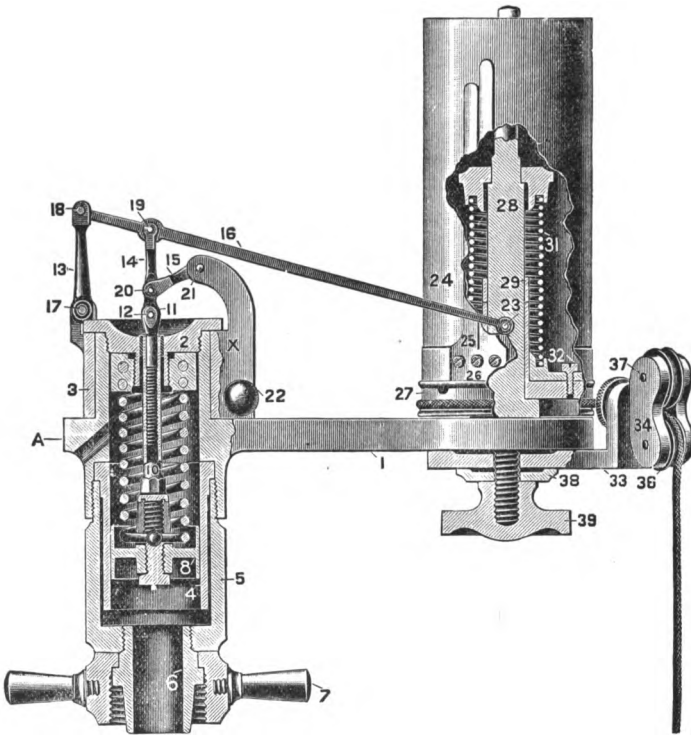

FIG. 14. Section of Crosby Indicator.

tact with its surface, and thus record any movement of either paper or pencil; the drum is given a horizontal motion coincident with and bearing a constant ratio to the movement of the piston of the engine. It is moved in one direction by means of a cord attached to the crosshead and in the opposite direction by a spring within itself.

“When this mechanism is properly adjusted and free communication is opened with the cylinder of a steam engine in motion, it is evident

that the pencil will be moved vertically by the varying pressure of steam under the piston, and as the drum is rotated by the reciprocating motion of the engine, if the pencil is held in contact with the moving paper during one revolution of the engine, a figure or diagram will be traced representing the pressure of steam in the cylinder, the upper line showing the pressure urging the engine piston forward, and the lower the pressure retarding its movement on the return stroke.

“To enable the engineer to more correctly interpret the nature of the pressures, the line showing the atmospheric pressure is drawn in its relative position, which indicates whether the pressure at any part is greater or less than that of the atmosphere.

“From such a diagram may be deduced many particulars which are of supreme importance to engine builders, engineers, and the owners of steam plants.”

The diagram is called an *indicator card* and is useful in determining the time at which the events of the stroke occur and also in getting an idea of the power of the engine.

{ Referring again to Fig. 12, which is an indicator card for the head end, when the piston is at any point M the pressure in the cylinder is represented by the length of the line MN . } The scale of ordinates on this particular diagram is $1'' = 60$ pounds. The line MN measures $\frac{73}{60}''$; therefore the pressure at that time is 73 pounds per square inch. { The ordinate at B shows the pressure at the beginning of the stroke, that at C the pressure at cut-off, the ordinate at R the pressure at release, the ordinate at K , the pressure at beginning of compression, and the ordinate at A the pressure at admission. On a card drawn by an indicator the points A, B, C, R and K can be determined by inspection and therefore the corresponding piston position can be found. } The average of all the ordinates of the upper part of the curve will give the average pressure exerted by the steam on the head end of the piston during the forward stroke. This average pressure multiplied by the area of the piston in square inches and by the length of the stroke in feet will give the foot pounds of work done by the steam on the head end of piston during that stroke. In a similar way the average of all the ordinates of the lower part of the curve will give the average pressure acting against the head end of the piston on the return stroke and this multiplied by the piston area in inches and length of the stroke in feet will give the foot pounds of work which the piston is obliged to do on the steam in the head end of the cylinder in order to make the return stroke. The difference of the

work done by the steam during the forward stroke and the work done against the steam during the return stroke will be the net work done by the steam on the head end of the piston during a complete revolution of the crank. The work done in the crank end can be found in the same way. The sum of the two will be the total work done on the piston during one revolution. This multiplied by the number of revolutions per minute and divided by 33,000 will give the horse power of the engine.

In actually making use of the card to find the power which the engine is developing the following method is commonly used. The area enclosed by the curve *ABCRK* is measured in square inches by an instrument called a planimeter. This area divided by the length of the card in inches will give the average of all the ordinates which represent net *effective* pressures, that is, the average of all the ordinates for the upper curve minus the average of the ordinates on the lower curve. This average net length of ordinate multiplied by the scale of the indicator spring gives the average effective pressure per square inch of piston area which is available throughout a complete revolution for work on that side of the piston. The name *mean effective pressure* (abbreviated M.E.P.) is commonly given to this quantity. Then $M.E.P. \times \text{area of piston in square inches} \times \text{length of stroke in feet} \times R.P.M. \div 33,000 = H.P.$ indicated by this card. The sum of this result and the corresponding one for the other end will give what is known as the *indicated horse power* of the engine (I.H.P.).

14. Types of Engines. Reciprocating steam engines may be classified in a variety of ways, some of which are as follows:

1. By position:
 - (a) Horizontal.
 - (b) Vertical.
2. By expansion of steam:
 - (a) Simple.
 - (b) Compound $\left\{ \begin{array}{l} \text{Cross compound.} \\ \text{Tandem compound.} \\ \text{Angle compound.} \end{array} \right.$
 - (c) Multiple-expansion.
3. By disposal of exhaust:
 - (a) Non-condensing.
 - (b) Condensing.
4. By kind of valve or valve mechanism.

15. Horizontal and Vertical Engines. In a horizontal engine the axis of the cylinder is a horizontal line while in a vertical engine it is a vertical line. In both cases the axis usually intersects the axis of the shaft. Fig. 15 illustrates a simple horizontal engine and Fig. 16 a simple vertical engine.

16. Simple, Compound and Multiple-expansion Engines. The steam may do all of its work in one cylinder, entering at practically boiler pressure and expanding down to the pressure at which it is delivered to the exhaust pipe, or it may do a part of its work in one cylinder, then exhaust directly into a second cylinder in which it does more work and from which it goes to the exhaust pipe, or the second cylinder may exhaust into a third. Even four or more are possible although not common. An engine in which all the expansion of the steam takes place in one cylinder is known as a simple engine. Both of those in Figs. 15 and 16 belong to this class.

An engine in which a second cylinder makes use of the exhaust from the first is called a *compound* engine. Fig. 17 shows a compound engine, of the kind known as *cross compound*, in which the two cylinders are side by side, each piston being connected to its own crank on the shaft. In the figure the cylinders themselves do not show to any extent as they are enclosed in the rectangular casings. It is evident, however, that the nearer cylinder, which is the "high pressure," is smaller than the other. This is to make allowance for the difference in steam pressures as it is desirable to distribute the work equally between the two. The box-like structure at the left of each cylinder encloses a rod known as a tail rod, which is really an extension of the piston rod running through the outer cylinder head. The tail rod helps support the weight of the piston so that the weight does not come on the cylinder walls. This feature is absent on nearly all small engines and on many larger ones. The exhaust from the high-pressure cylinder is delivered either directly into the supply pipe for the low-pressure cylinder or else into a closed chamber, known as a receiver, from which the "low" draws its supply.

Fig. 18 shows a *tandem compound* in which the two cylinders are in line, both pistons being on the same piston rod. The pipe which carries the exhaust from the high-pressure cylinder to the low is plainly seen in this picture.

In Fig. 19 is shown an *angle compound* engine where the high-pressure cylinder is horizontal and the low-pressure cylinder vertical.

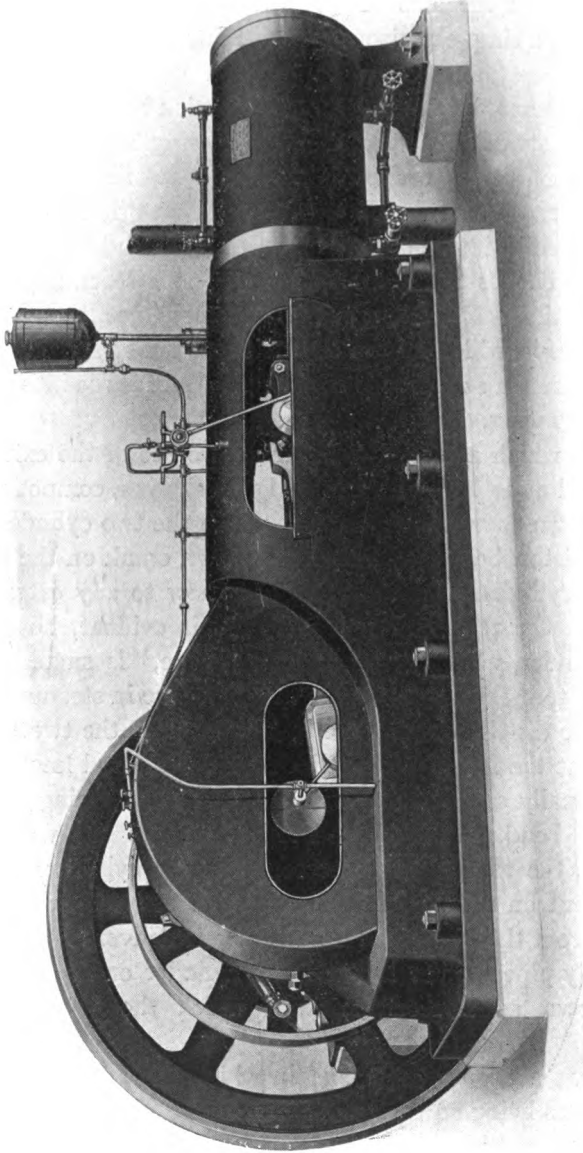

FIG. 15. Horizontal Engine, Buckeye Engine Co.

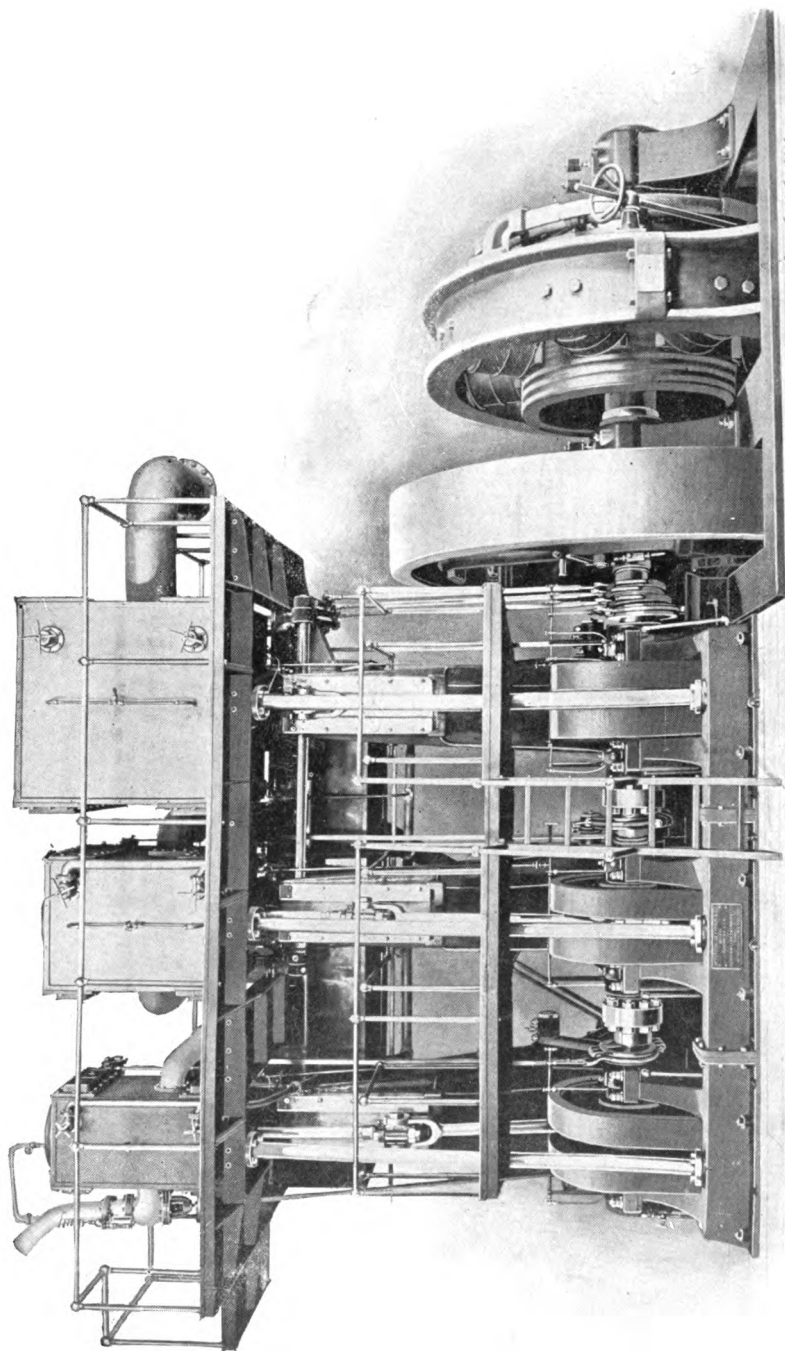

FIG. 20. Vertical Triple-expansion Engine. McIntosh & Seymour Co.

of valve as a basis, stationary engines may be roughly divided into three classes.

1. Single-valve engines in which a single valve controls all the events, as in the case of the engine described in § 2.
2. Double-valve engines, in which one valve controls the admission and the exhaust events, and an auxiliary valve is used to control the cut-off.
3. Multiple-valve engines, which have three or more valves.

In the case of locomotive engines, marine engines and certain others, it is necessary to so arrange the valve gear that the direction of rotation may be quickly reversed. Such engines are known as reversing engines, and the mechanism driving the valve is described as a reversing gear.

19. The relative advantages of the various types which have been mentioned cannot properly be discussed at this time. What has been said, however, will serve to acquaint the student with the fact that the various types exist and will permit of reference being made to them incidentally as may seem necessary in considering the different questions connected with the mechanism of the engines.

CHAPTER II

SINGLE-VALVE ENGINES

20. The general arrangement of the valve gear for a simple single-valve engine has been shown in Fig. 1. The valve there shown is a plain-slide or *D* valve. Fig. 21 is a perspective drawing of a similar valve and Fig. 22 gives three orthographic views of the same. This is the simplest form of single valve and although not so much used at the present time on important engines as some of the more complicated forms of valves, the fundamental principles of design and action can be more clearly understood from the simple valve.

21. **Laps.** The valve is ordinarily made of such dimensions that it overlaps the edges of the ports when in mid-position, as shown in Fig. 23. The amounts by which the edges of the valve overlap the corresponding edges of the ports when in mid-position are called the *laps*. In Fig. 23, L_h is the head-end steam lap, L_c the crank-end steam lap, N_h the head-end exhaust lap and N_c the crank-end exhaust lap.

The steam laps are always positive quantities and may or may not be equal. (The exhaust laps may be positive, as in Fig. 23, or zero, as in Fig. 24, or negative, as in Fig. 25.) A negative exhaust lap like N_h , Fig. 25, is spoken of as an exhaust clearance. It not infrequently happens that the valve needs to be designed with an exhaust lap at one end and exhaust clearance at the other.

22. **Lead and Lead Angle.** Experience has shown that it is often desirable to have the admission of steam occur just before the piston reaches the end of the stroke, so that when the crank reaches the dead point the valve will have opened the port by a small amount for admission of steam. The amount by which the port is open at that time is called the *lead*, designated as head-end lead and crank-end lead respectively, according as the crank is on the head-end or crank-end dead point.

The angle which the crank makes with the dead point position when admission occurs is called the *lead angle*.

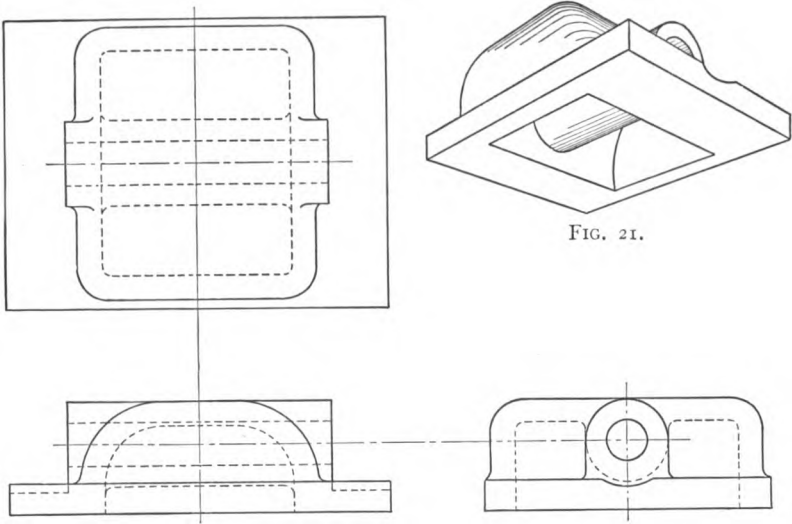

FIG. 21.

FIG. 22.

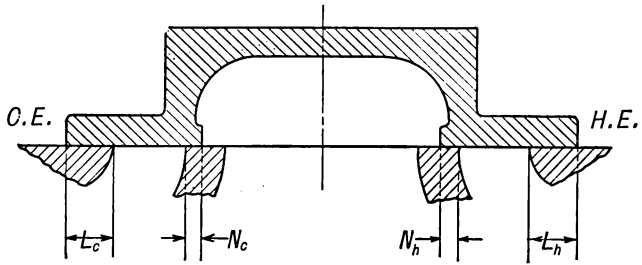

FIG. 23.

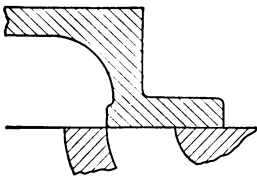

FIG. 24.

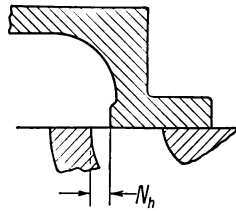

FIG. 25.

23. Angle Between Crank and Eccentric. The position of the eccentric relative to the crank depends upon a number of conditions, such as type of valve, connection between eccentric and valve, and time of admission and cut-off.

The general statement may be made, however, that the eccentric should be so set relative to the crank that when the crank is at the proper place for admission to occur the valve will be displaced the proper amount to be just uncovering the port and moving in the proper direction to open the port.)

24. Angular Advance is a term often used in text-books and in discussions of valve gears. It signifies the angle through which the eccentric must be turned to move the valve from mid-position a distance sufficient to open the port by an amount equal to the lead. An equivalent definition is the angle which the crank makes with the dead point position when the valve is in mid-position.

25. Position of the Mechanism for the Different Events of the Stroke. Figs. 26 to 32 show the valve mechanism and the reciprocating parts (piston, crosshead, connecting rod and crank) in the positions which they occupy for the several head-end conditions. In Fig. 26 (head-end admission is just taking place; the piston is nearly at the head-end dead point position. The valve is displaced toward the crank end an amount equal to the head-end steam lap and is moving toward the crank end.

In Fig. 27 the piston (is at the head end of its stroke and the valve has moved a little farther toward the crank end, causing a small lead opening for steam to flow into the head end of the cylinder.)

Fig. 28 shows the mechanisms when the valve is displaced toward the crank end its maximum amount and the head-end port has its maximum opening for admission of steam.

Fig. 29 head-end cut-off is just taking place. It should be noted there that the valve is in the same place as when admission was beginning, (Fig. 26) but is moving in the *opposite* direction.

Fig. 30 shows the mechanisms when the valve is in mid-position, moving toward the head end.

Fig. 31 shows the position for head-end release and Fig. 32 for head-end compression. Here again it is to be noted that the valve is in the same position in each case, but is moving to open the exhaust in Fig. 31 and to close it in Fig. 32. A similar series of diagrams could, of course, be drawn for the crank end.

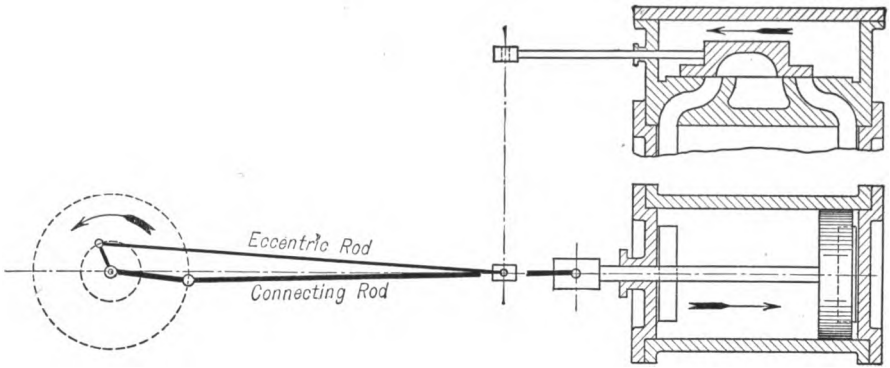

FIG. 26. Head-end Admission.

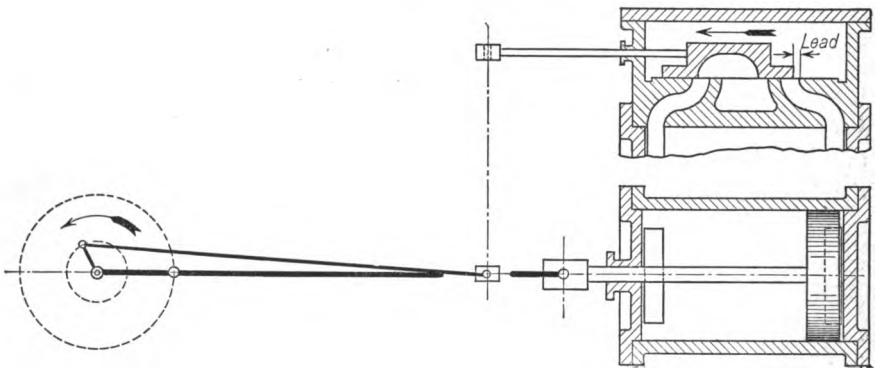

FIG. 27. Head-end Dead Point.

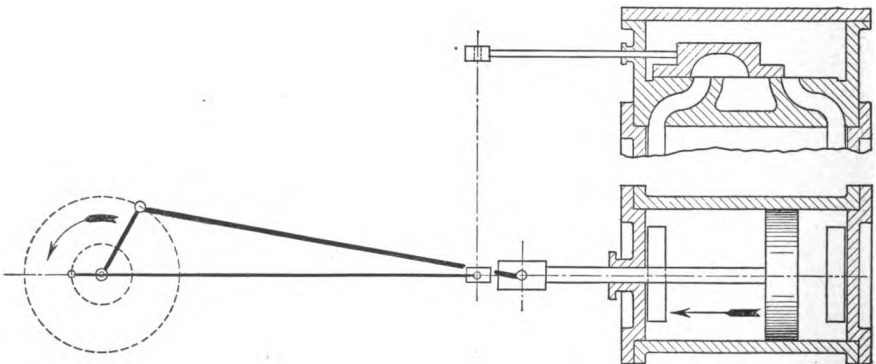

FIG. 28. Extreme Valve Displacement.

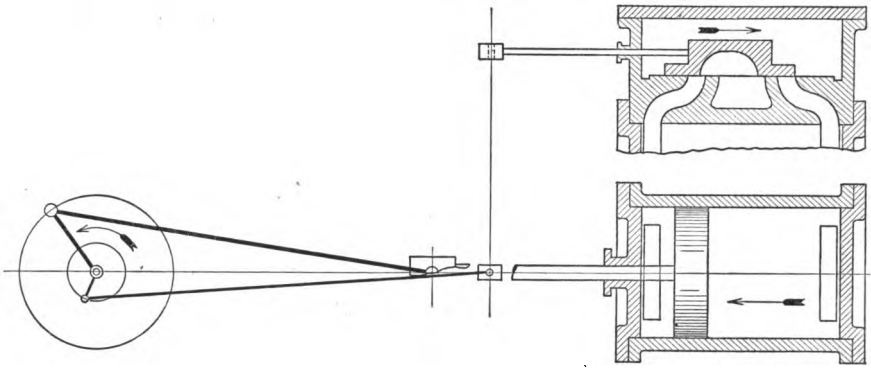

FIG. 29. Head-end Cut-off.

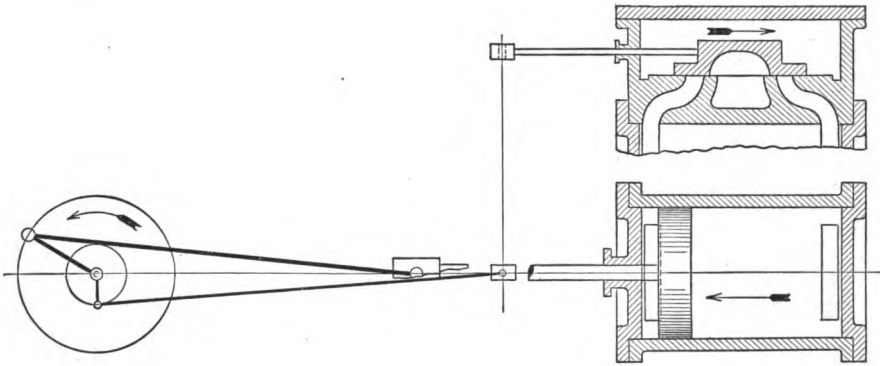

FIG. 30. Mid-position.

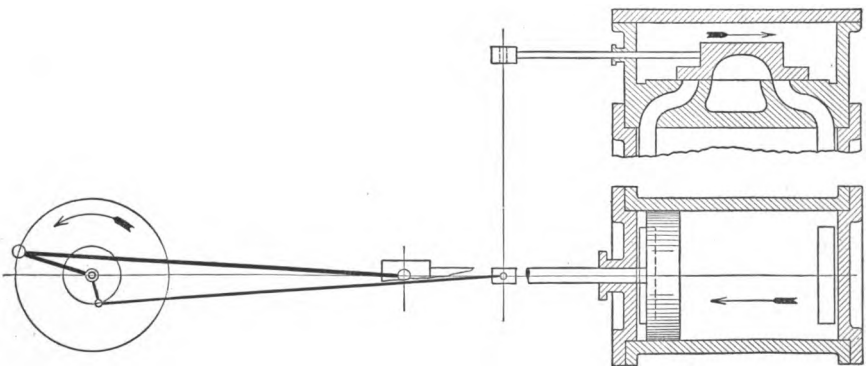

FIG. 31. Head-end Release.

26. A study of the Figs. 26 to 32 will make clear the following facts:

1. When the engine is at admission the valve is displaced an amount equal to the steam lap and moving in the direction to *uncover* the port.
2. When the engine is at cut-off the valve is in the same position as at admission for the same end but moving in the direction to *cover* the port.
3. When the engine is at release the valve is displaced an amount equal to the exhaust lap and moving to *uncover* the port.
4. When the engine is at the beginning of compression the valve is in the same position as at release for the same end but moving to *cover* the port.

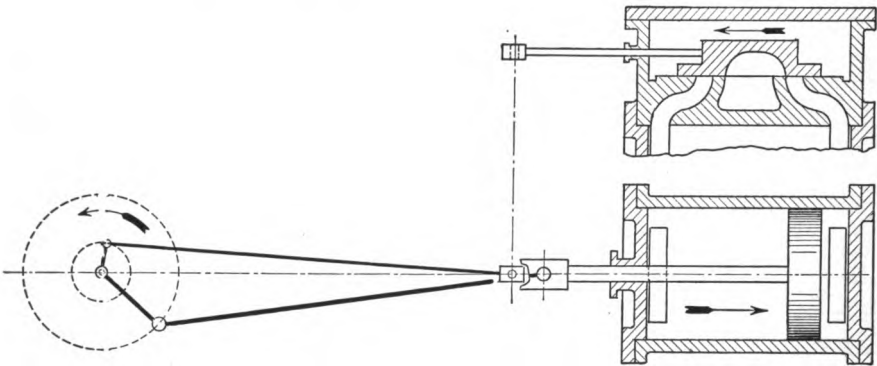

FIG. 32. Head-end Compression.

27. **Equal Events.** When the valve mechanism is so designed that the lead is the same on both the head and crank ends the engine is said to have equal leads. When head-end cut-off occurs at the same percentage of the forward stroke as does crank-end cut-off of the return stroke the cut-offs are said to be equal. If compression occurs at the same percentage of the stroke on both strokes the compressions are equal and similarly with reference to the release.

28. The following statements may well be made at this time although their full force may not be apparent until a study is made of valve diagrams and problems in Chapters III and IV. These statements are intended to apply to plain slide valves which have approximately harmonic motion, on engines where the ratio of connecting rod to crank is such that the piston does not have harmonic motion.

1. If the leads are equal the steam laps must be equal and the cut-offs will be unequal.
2. If the cut-offs are equal the steam laps will be unequal and therefore the leads will be unequal.
3. Equal releases or equal compressions require unequal exhaust laps.
4. If the valve has a positive exhaust lap release will occur after the valve has passed mid-position and compression will occur before the valve again reaches mid-position.
5. If the valve has an exhaust clearance release will occur before the valve reaches mid-position and compression will not occur until after the valve again passes mid-position in the reverse direction.

29. Modification of the Slide Valve. In many cases valves are used which, while they are slide valves and governed by the same principles, are modified in various ways. We will now consider a few of these modifications. The examples mentioned are chosen chiefly because they will illustrate the types which they represent, no attempt being made to cover the entire field.

30. Piston Valve. Fig. 33 shows a simple form of piston valve. This is essentially a plain slide valve except that it is cylindrical, fitting nicely into a cylindrical chest. The ports spread out around the chest so that steam is admitted or exhausted around practically the entire circumference.

A piston valve of a little more complicated construction is shown in Fig. 34. This is a large valve for use on a locomotive and is provided with packing rings to prevent leakage. Here the valve chest is fitted with liners, a drawing of which is given in Fig. 35.

31. Balanced Valves. A plain *D* valve has the full steam-chest pressure on its entire outer surface while its inner surface is either in contact with the seat or subjected only to exhaust pressure, except possibly the small area which may be over the ports and subject to whatever pressure is in the cylinder. The result is a heavy unbalanced pressure, forcing the valve against its seat. This means a heavy friction load on the gear which moves the valve.

The piston valve is not open to this objection since the pressure on it is equal all around the circumference. There is greater liability of leakage past a piston valve, however, especially after it has become worn, or has worn the seat non-cylindrical.

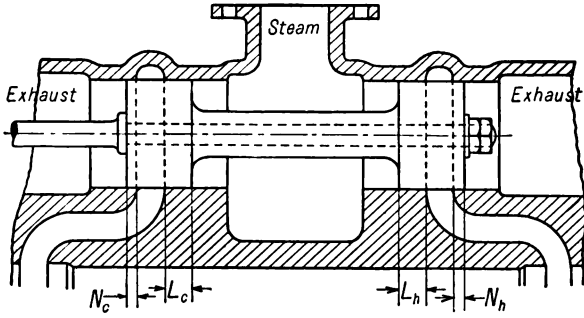

FIG. 33. Simple Piston Valve.

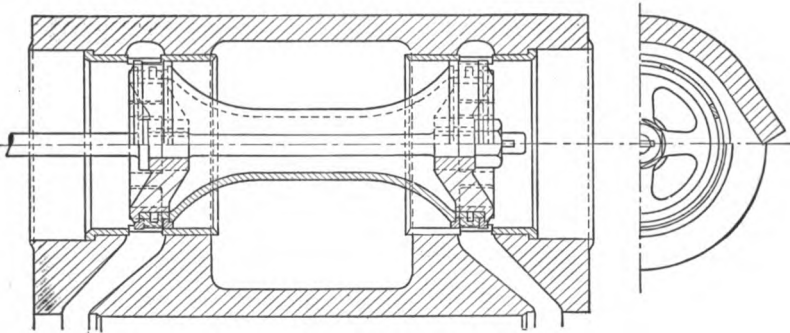

FIG. 34. Locomotive Piston Valve.

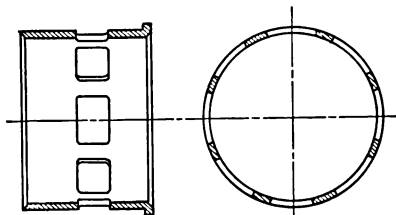

FIG. 35. Bushing for Piston-valve Seat.

Various devices have been used to relieve a portion of the unbalanced pressure on the flat seated valve.

An example of a balanced valve is shown in Fig. 36. A pressure plate *P* is bolted to the steam-chest cover. A piece *R* fits into a groove

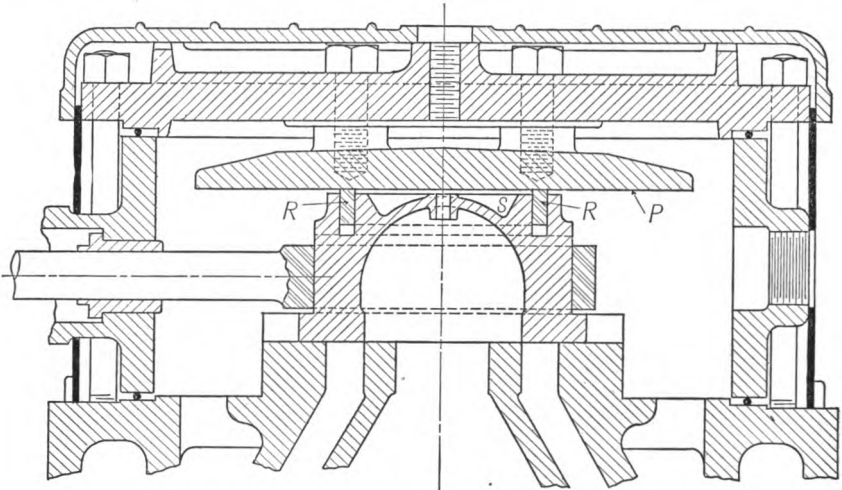

FIG. 36. Locomotive Balanced Valve.

in the top of the valve and is held by flat springs against the finished under surface of the pressure plate so as to make practically a steam-tight joint and thus shut out the high-steam pressure from the space *S*

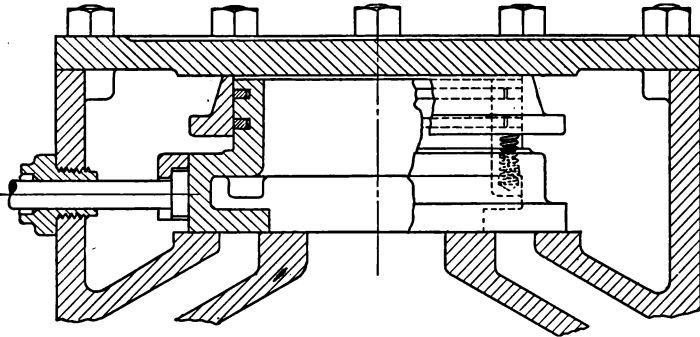

FIG. 37. Skinner Balanced Valve.

enclosed within it. *R* may be a circular ring or a rectangular frame. A small hole connects the space *S* with the exhaust cavity so that the pressure within *S* is equal to the exhaust pressure.

Another method of balancing is illustrated by the valve in Fig. 37. The valve is open through the center and has a cylindrical hub on its

back. In this hub are grooves into which fit packing rings. Over the hub fits a sleeve, and the packing rings form a steam tight joint between the inside of the sleeve and the hub. The outer end of the sleeve rests against the finished inner surface of the steam-chest cover, sliding with the valve and held tightly against the cover by four helical springs, one of which shows in the drawing. In this way the area of the valve exposed to high steam pressure is reduced and the force required to move the valve is made less.

Figs. 38 and 39 represent a balanced valve used on the Ball engine. The valve is a double affair, having an upper and lower face which are alike. The lower part has a hub which is hollow, while the upper part

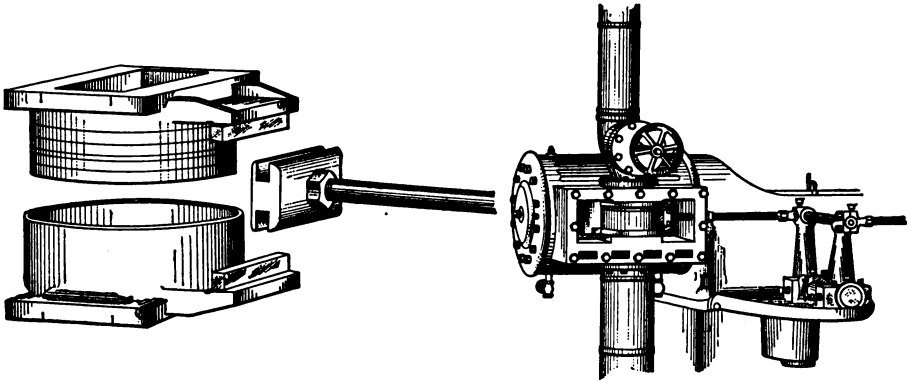

FIG. 38. American-Ball Engine Valve.

FIG. 39. American-Ball Engine Cylinder and Steam Chest.

has a hub which fits into the lower one and the fit is made steam tight by spring packing rings. Thus the two parts may telescope into each other without leakage. The method of connecting the stem to the valve is clearly shown in Fig. 38. A part of the engine in which this valve is used is seen in Fig. 39, where the steam-chest cover is removed. It will be seen that each part of the valve has its own seat and ports. The ports from the upper and lower seats unite and then pass into the cylinder as one large port at each end.

The action of the valve is as follows: Steam passes through the throttle valve, shown in Fig. 39, to the interior of the valve, is admitted to and cut off from the cylinder by the inside edges, and is exhausted from the cylinder by the outside edges. Thus the valve has steam at exhaust pressure only, surrounding it. The lower part is pressed to its seat

and the upper part to its seat by the low-pressure exhaust steam acting on the area of that part of the valve outside of the hub.

From the construction, the two halves of the valve are able to lift from their seats and telescope into each other, should there be excessive pressure in the cylinder, due to water, or other cause.

32. Ported Valves. The proportions of an engine are sometimes such that it is difficult or even impossible to give sufficient travel to a plain slide valve to open the port far enough to give proper admission of steam. Furthermore, a plain slide valve gives a very narrow port opening at first and requires some time to open the port enough to allow free flow of steam. Consequently the piston may have moved some distance from the end of the stroke before full steam pressure is attained in the cylinder. Similarly when the valve is covering the port, the closing is gradual, with a consequent dropping of pressure. For these and

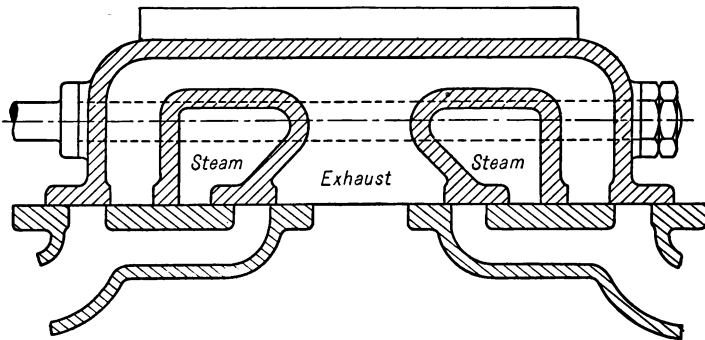

FIG. 40. Double-ported Valve, Marine Type.

other similar reasons, valves are often constructed with auxiliary passages through them.

Fig. 40 is a section of a valve, known as a double-ported valve, used on marine engines. The two openings marked "steam" pass completely through the valve, and thus the live steam which surrounds the valve is enabled to fill these spaces. At each end of the valve seat are two small ports, which merge into large ones connecting with the cylinder. Each of these ports has a valve foot covering it, the feet on the same end being duplicates. It is apparent that both ports on the same end are uncovered simultaneously and the fact that there are two openings does much to overcome the difficulties above mentioned.

Figs. 41 and 42 are sections through a ported valve which has sometimes been called a "Trick valve." It differs from the ordinary slide

valve by having the passage *A* cored through it. Referring to Fig. 41, where the valve is in mid-position, the distance from the edge *K* to the edge *M* of the recess in the seat is just equal to the head-end steam lap, so that when the steam begins to flow into the head-end port past the head-end edge of the valve in the usual way it also begins to flow past

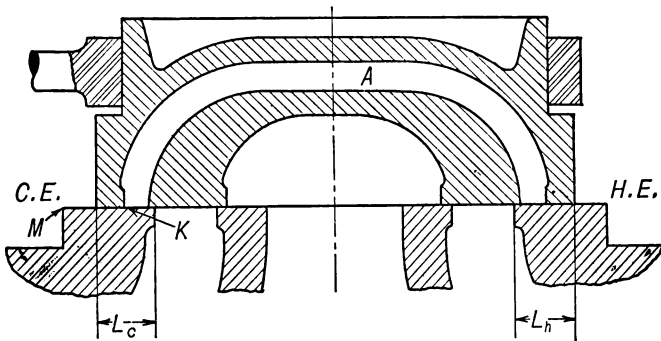

FIG. 41. Allen Locomotive Valve in Mid-position.

the edge *K* into the passage *A* and around into the head-end port. In Fig. 42 the valve is shown with the port open a little and the action of the auxiliary passage *A* is evident. When the valve has moved farther toward the crank end the passage *A* is stopped off by the head-end bridge, but this is not important as the main opening in the head-end port will

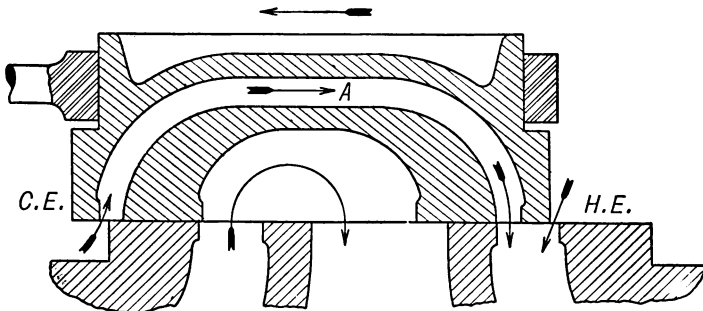

FIG. 42. Allen Locomotive Valve at Lead Opening.

then be ample. When the valve moves back and approaches head-end cut-off the auxiliary passage again comes into action and the flow through this passage is cut off at the same time that the regular cut-off takes place. The action is exactly similar when steam is flowing into the crank end. The effect of the auxiliary passage is to produce the equiv-

alent of a more rapid opening of the port at admission and a more rapid closing at cut-off. This valve has been used to a considerable extent on locomotives.

Figs. 43 and 44 show the valve, valve chest and cylinder of a Ridg-

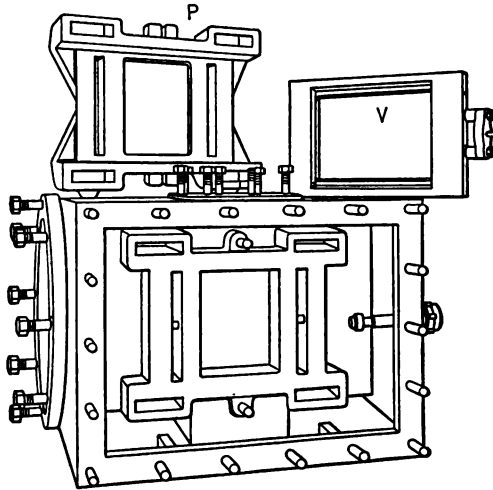

FIG. 43. Valve, Valve Chest and Pressure Plate of Ridgway Engine.

way engine. This valve has the "trick" feature for exhaust as well as for admission. The valve *V* is a rectangular frame sliding between its

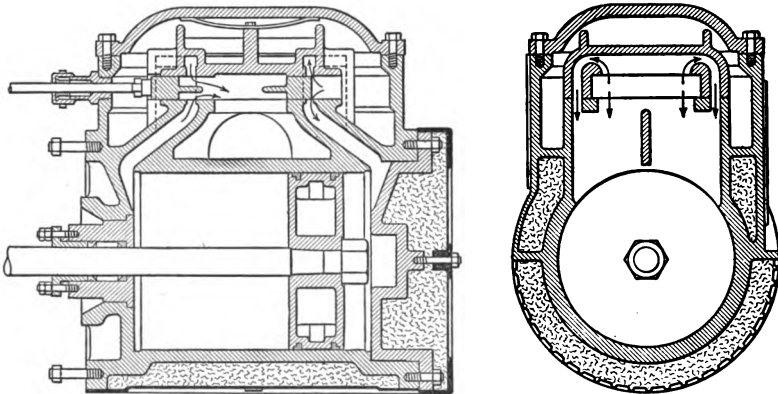

FIG. 44. Cylinder, Valve Chest and Valve of Ridgway Engine.

seat and the pressure plate *P*, which encloses it on three sides. The pressure plate has auxiliary passages through it which bend around and communicate with the cylinder ports. The arrows in Fig. 44 show the

steam flowing into the head end and out of the crank end in the usual way and also through the auxiliary passages.

33. Crank and Eccentric for Piston Valve. Piston valves are usually designed to have the supply of high steam around the middle portion of the valve, with the exhaust passing out at the ends. That is, they "take steam at the middle." The inside laps L_h and L_c , Fig. 33, are, therefore, the steam laps, and the outside laps N_h and N_c are the exhaust laps. This, of course, necessitates that the displacement and direction of motion of the valve for any given event must be just the

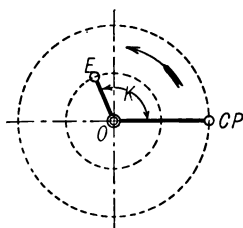

FIG. 45. *D* Valve Direct.

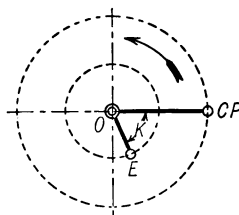

FIG. 45a. Piston Valve Direct.

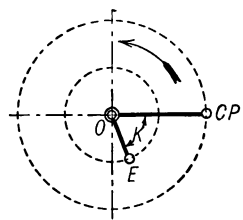

FIG. 46. *D* Valve with Reversing Rocker.

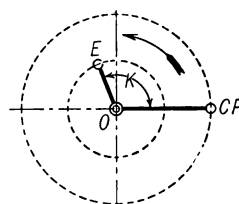

FIG. 46a. Piston Valve with Reversing Rocker.

reverse of that for a plain slide valve taking steam on the outside. This reversal of direction is accomplished by setting the eccentric diametrically opposite on the shaft.

Fig. 45 indicates the position of the eccentric relative to the crank for the ordinary *D* valve driven direct; Fig. 45a for a piston valve which takes steam in the middle, driven direct; Fig. 46 for a *D* valve driven through a reversing rocker; Fig. 46a for a piston valve driven through a reversing rocker. Comparing Figs. 45 and 46a it will be seen that the eccentric is set the same for a *D* valve driven direct and a piston valve driven through a reversing rocker. A similar comparison between Figs. 45a and 46 shows the same setting for a *D* valve driven through a rocker as for a piston valve direct.

CHAPTER III

VALVE DIAGRAMS

34. In order to design a valve and its driving mechanism to accomplish certain ends or to investigate the action of a given valve gear it is desirable to have some graphical method whereby the displacement of the valve may be quickly determined for any known piston or crank position or vice versa. There are a number of such diagrams which have been used. The most common of these are as follows:

Valve ellipse — applicable to any valve.

Zeuner's diagram	} Applicable only to valves having harmonic or approximately harmonic motion.
Reuleaux diagram	
Bilgram diagram	

All of these diagrams are satisfactory and we shall study the valve movements by the aid of one of these, except in special cases where other methods may be more convenient. Any such diagram must be interpreted by intelligent reference to the actual mechanism to which it is being applied. The diagram will mean nothing to the person who merely memorizes certain facts about it and who tries to read results from it in the light of what he remembers. He must be able, when looking at the diagram, to picture in his mind just what the valve, valve gear, piston and crank are doing at any given time. Unless this condition is fulfilled the use of any diagram is liable to lead to serious errors.

35. **The Valve Ellipse.** The valve ellipse is a curve plotted with piston positions for abscissæ and valve displacements, measured from mid-position, corresponding to those piston displacements, for ordinates. It is customary to plot piston displacements to a reduced scale and valve displacements full size. Displacements of the valve toward the crank end are usually plotted above the datum line and displacements toward the head end below the line. This point is not essential however. If the motions of both valve and piston are harmonic, the curve is a true ellipse, but if the motion of either valve or piston is not harmonic, then the curve deviates from the true ellipse. The name *valve ellipse* is

applied, whatever the form of the curve. An engine may be made to draw its own ellipse by means of a simple attachment.

Fig. 47 is a valve ellipse for an engine with a plain D valve, having approximately harmonic motion. The piston motion is not harmonic and the distortion of the ellipse due to this fact is apparent. The piston stroke is plotted at a small scale, while the valve displacements may be assumed to be full size. Ordinates above $X_h X_c$ indicate valve displacements towards the crank end. Let us start with the piston at A moving toward the head end. The ellipse crosses the line $X_h X_c$ at this point and therefore the valve is in mid-position and moving toward the crank end. When the piston reaches the end of the stroke the valve is dis-

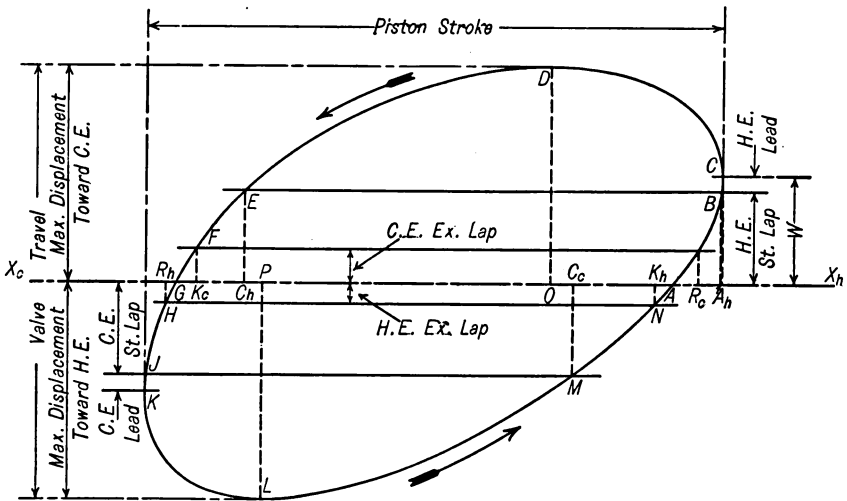

FIG. 47.

placed a distance W . The piston now starts on its forward stroke, the valve still continuing to move toward the crank end until the piston reaches O when the valve attains its greatest displacement and starts back toward the head end. When the piston is at G the valve is again in mid-position, moving toward the head end. When the piston reaches P on the return stroke the valve has its greatest displacement toward the head end.

The application of the diagram may be seen from the following: If a line is drawn parallel to and above $X_h X_c$, at a distance from it equal to the head-end steam lap, this line cuts the ellipse at B and E . Therefore head-end admission occurs when the piston is at A_h since at that

time the valve is displaced toward the crank end an amount equal to the head-end steam lap and is moving toward the crank end. At the time the piston is at the head-end dead point (so close to A_h that the difference barely shows in the drawing) the valve displacement is W . Therefore the head-end lead is W minus A_hB . By dropping a perpendicular from E meeting X_hX_c at C_h the piston position for head-end cut-off is found since at that time the valve has the same displacement as at head-end admission and is moving toward the head end which is the proper position and direction for a D valve to close the head-end steam port.

Since a D valve with a head-end exhaust lap must be displaced toward the head end in order to bring the inside edge of the valve to the edge of the port, if we draw a line parallel to X_hX_c , below it and distant from it equal to the head-end exhaust lap, then release and compression for the head end will occur when the piston is at R_h and K_h respectively. The events of the stroke, lead opening, etc., for the crank end may be found in a similar manner. Of course the process may be reversed; for example, if the per cent of stroke at which head-end cut-off is desired is known, the head-end steam lap, lead opening, etc., may be found. As every irregularity in the motion of both piston and valve are taken into account in drawing the valve ellipse, it is a particularly useful diagram when the motion of the valve deviates greatly from harmonic, as it does in some complicated valve gears.

36. Zeuner's Diagram. If, instead of plotting the valve displacements as ordinates in a rectangular plot as in the valve ellipse, they are plotted on the center line of the crank, we obtain a polar curve whose angles are crank angles and whose distances from the pole are valve displacements. Therefore the valve displacement for any given crank position as OB , Fig. 48, is the distance OT from the origin (center of the crank shaft) to the point where the center line of the crank cuts the curve. For the position OM and OM_1 where the crank line is tangent to the curve the valve is in mid-position. When the crank line intersects the upper curve the valve is displaced to one side of mid-position and when it intersects the lower curve the displacement of the valve is toward the other side of mid-position. With the ordinary slide valve driven direct the upper curve represents displacements toward the crank end and the lower curve toward the head end.

If this curve be plotted for a valve which has harmonic motion the two curves become circles, as shown in Fig. 49, the diameter of each

found by drawing a perpendicular from B to OE , will give us the same value as OD . That is, OT_1 is the valve displacement when the crank is at OB , the length OB being made equal to one half the valve travel. The same result is evidently obtained by drawing from E a perpendicular to the crank. We then have one point T on the polar plot shown in Fig. 49. If now we can show that the locus of the point T is a circle, as the crank revolves, we will have proved that the curves in Fig. 49 are circles. To show that the locus of T is a circle draw a line from T to P , the middle of OE . Draw PW perpendicular to ET . Then from the similarity of the triangles EPW and EOT , EW must be equal to WT since $EP = PO$. Then in the two right triangles EWP and TWP , $EW = TW$ and WP is common. Therefore the triangles are equal and $TP = EP = OP$. Therefore the points E , T and O are on a circle whose center is P . Since O and E are fixed points and OB is any crank position, the point T will always be on the circle. A similar line of reasoning of course applies to the lower curve. The two circles are called valve circles.

In Fig. 49 the lines OM and OM_1 , which are tangent to the circles at O , show crank positions when the valve is in mid-position. Therefore angle X_1OM_1 and X_2OM are equal to the angular advance. These lines are, of course, perpendicular to E_1OE , therefore the angle EOY is equal to the angular advance.

Following the motion of the valve from Fig. 49, — when the crank is at OE_1 the valve has its extreme displacement toward the head end and is just starting to move toward the crank end; it reaches mid-position when the crank reaches OM_1 ; after the crank passes OM_1 the valve is displaced towards the crank end and continues to move toward the crank end until the crank reaches OE . Then the valve has its extreme displacement toward the crank end and starts to move toward the head end. It reaches mid-position again when the crank gets to OM , and again goes to the head-end side of mid-position after the crank passes OM .

37. Application of the Zeuner's Diagram. The method of using the Zeuner's diagram is similar to that for the valve ellipse with the modifications necessary because it is a polar plot. Referring to Fig. 51, arcs are swung about the pole O with radii equal to the respective laps and on the side of the mid-position line MOM_1 toward which the valve must be displaced to have the various edges act. The crank positions for the various events are found by drawing from O through the points where the lap circles cut the valve circles, identifying the

various events by thinking which way the valve is displaced and which way it is moving.

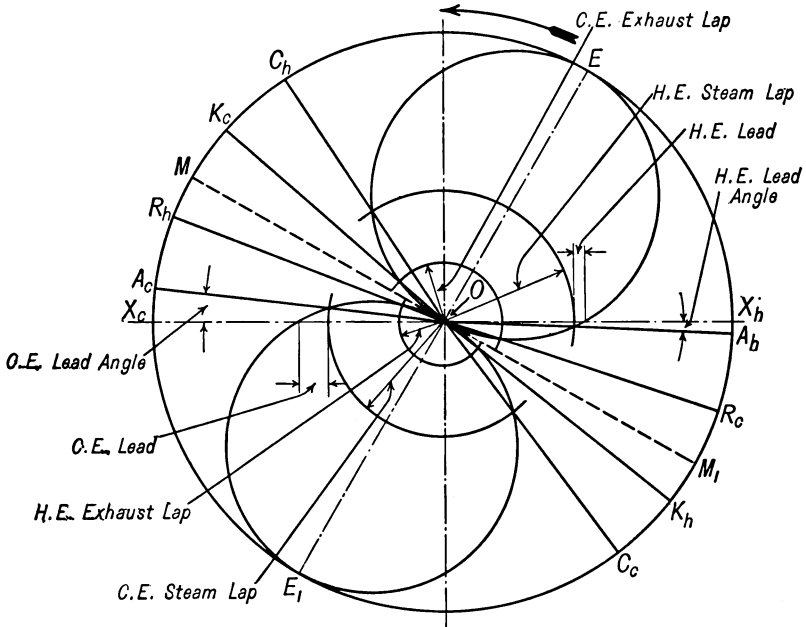

FIG. 51.

38. Reuleaux Diagram. A diagram which in some cases is more convenient than the Zeuner's diagram is the one sometimes known as the Reuleaux diagram.

In Fig. 52 a circle is drawn with O as a center and radius equal to one half the valve travel. We will refer to this circle as the *eccentric circle* since it is the path of the center of the eccentric if the valve is direct connected, or if the valve is driven by an unequal armed rocker it would be the path of the center of a direct-connected eccentric which would give the same valve travel. Let OC be the crank and let the angle between the crank and the eccentric be K . For any crank position OC the eccentric center is at N , found by laying off the angle K ahead of or behind the crank according as the eccentric is set to lead or follow the crank. If the valve has harmonic motion its displacement is OD . If, now, we draw the line E_1OE making the angle X_cOE equal to K , and if from B , where the crank line crosses the eccentric circle, we drop a perpendicular BT to OE , then OT is equal to OD and is the valve dis-

placement for this crank position. The same holds true for any crank position.

The construction for this diagram merely consists, therefore, in drawing the eccentric circle, and then the line E_1OE making an angle X_cOE

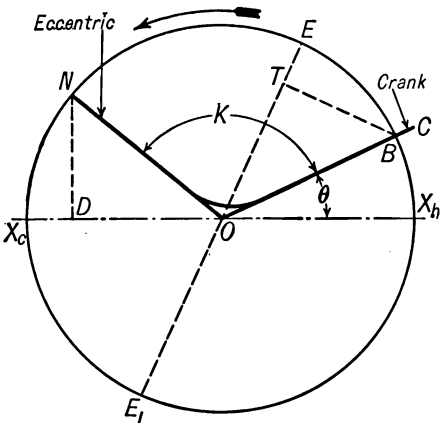

FIG. 52.

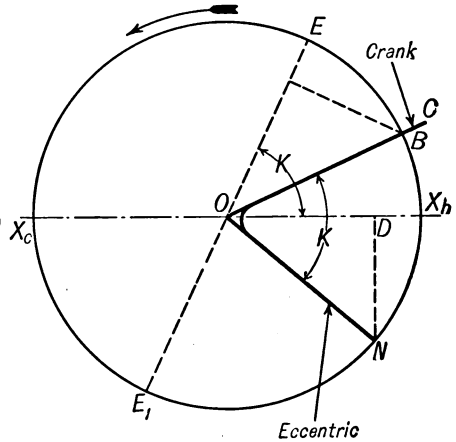

FIG. 53.

with the engine center line equal to the angle which the eccentric makes with the crank. Then the valve displacement for any given crank position is the distance from the center of the circle to the foot of a perpendicular drawn from the point where the crank cuts the eccentric circle to the line E_1OE . The line E_1OE may be called the *reference line*.

The construction for a case where the eccentric follows the crank is shown in Fig. 53, where the letters have the same meaning as in Fig. 52.

It will be noticed that the reference line of the Reuleaux diagram is the same line as the valve circle diameter of the Zeuner's diagram.

39. Application of the Reuleaux Diagram. Fig. 54 is a complete diagram which is self explanatory.

40. The Bilgram Diagram. With center O , Fig. 55, draw a circle whose radius is one half the valve travel. Let OM be any position of the center line of the crank, making an angle θ with the head-end dead-point position. From OX_c lay up the angle X_cOB equal to the angular advance, getting the point B . From B drop the perpendicular BD to the center line of the crank or of the crank produced. Then BD is the valve displacement for the crank position OM .

Proof: In Fig. 56, if SC is the center line of the crank corresponding

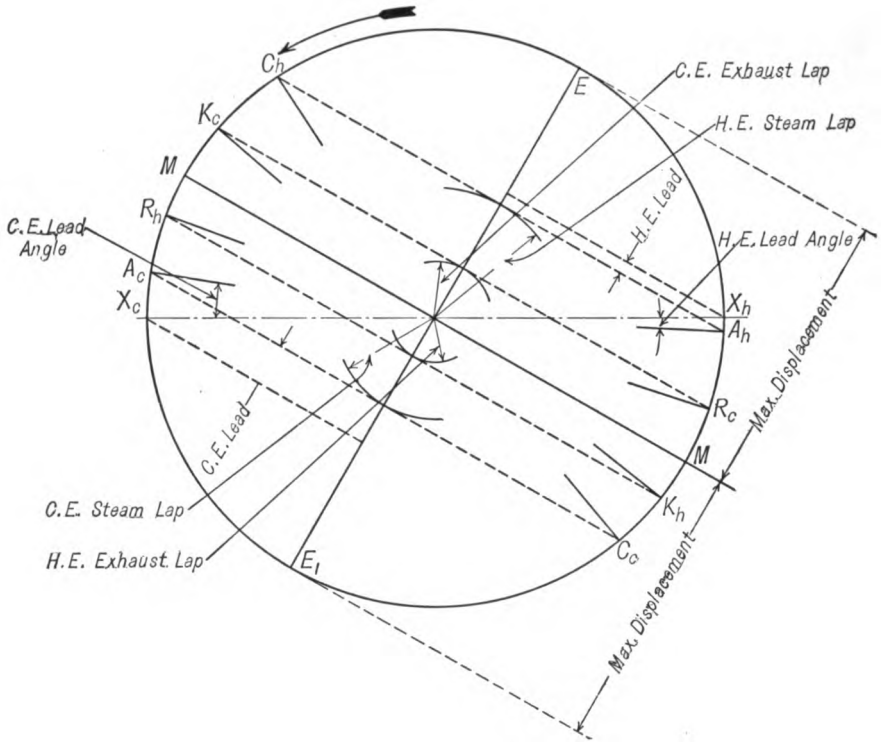

FIG. 54.

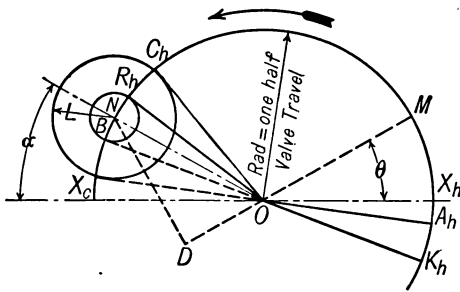

FIG. 55.

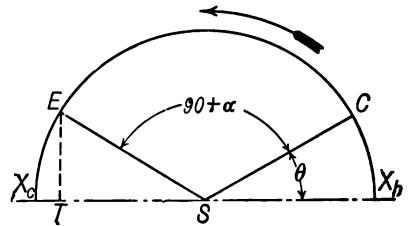

FIG. 56.

to position OM in Fig. 55, E is the actual position of the eccentric center. Then ST is the valve displacement if the valve has harmonic motion.

$$\begin{aligned} EST &= 180^\circ - (90^\circ + \alpha + \theta) \\ &= 90^\circ - (\alpha + \theta). \end{aligned}$$

In Fig. 55,

$$BOD = (\alpha + \theta).$$

Therefore $OBD = 90^\circ - (\alpha + \theta)$.

Hence $OBD = EST$ and since $OB = SE$ the triangles EST and OBD are equal.

Therefore $BD = ST$.

Referring still to Fig. 55, if L is equal to the head-end steam lap and N the head-end exhaust clearance,

A_h is the crank position for H.E. admission.

C_h is the crank position for H.E. cut-off.

R_h is the crank position for H.E. release.

K_h is the crank position for H.E. compression.

CHAPTER IV

TYPICAL PROBLEMS ON THE SLIDE-VALVE ENGINE

41. The following examples will serve to illustrate the manner of studying the action or design of a slide-valve mechanism, certain proportions of which are known. An understanding of the constructions here given will also give more familiarity with the slide valve, its possibilities and its limitations, than could be obtained in any other way. The student should constantly guard against becoming so involved in the geometry of the diagrams that he loses sight of the real mechanism.

- 42. Given:** *Ratio connecting rod to crank* = 4 to 1.
Ratio eccentric rod to eccentricity = 6 to 1.

Valve to be a plain D valve driven direct. Angle between crank and eccentric known; eccentricity known; piston positions for cut-off and compression known for both ends.

To find: Laps, leads and piston positions for release.

Here the ratio of eccentric rod to eccentricity is so small that the valve motion departs materially from harmonic motion. Consequently any one of the diagrams which depends upon harmonic motion of the valve would be inaccurate in this case. The valve ellipse, however, takes into account all the irregularities and can be used. The first step will be the plotting of the ellipse. This is shown in Fig. 58, where the valve displacements are taken from Fig. 57. The method of plotting the ellipse should be clear from the discussion in § 35. Having plotted the ellipse, Fig. 58, the piston positions for cut-off and compression are located on the stroke of the cross head pin. These are lettered C_h , C_c , K_h and K_c . From these positions perpendiculars are erected and the lap lines drawn through the points where these perpendiculars cut the ellipse. To determine which intersection to use in each case it is necessary to reason out which way the piston is moving and which way the valve is displaced and moving for the event under consideration. The lead is found by taking the difference between the laps and the displacement of the valve when the crank is on the dead point. The piston

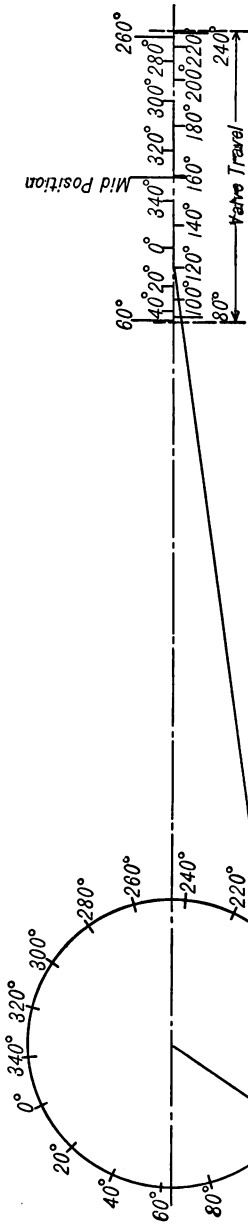

FIG. 57.

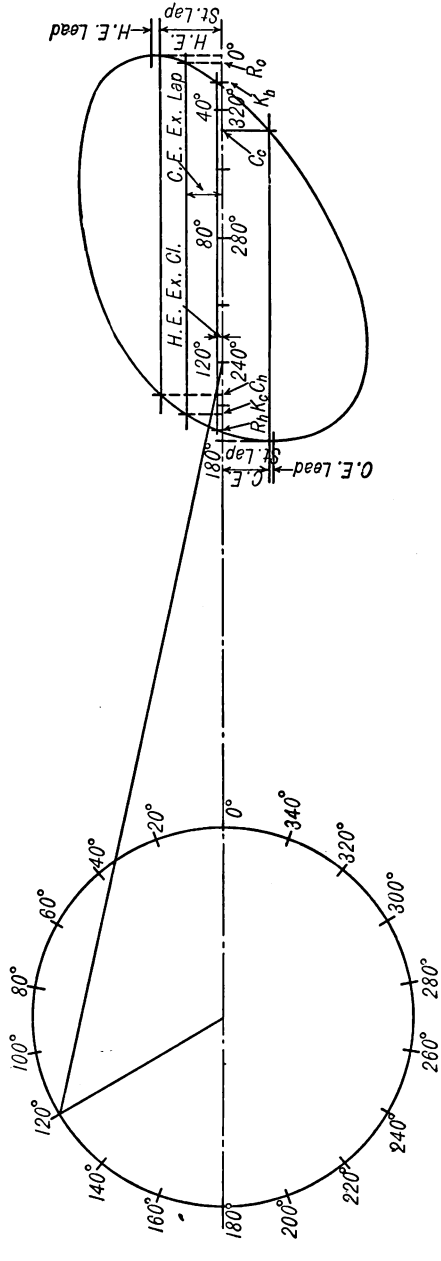

FIG. 58.

positions for release are found by dropping perpendiculars from the proper intersections of the exhaust lap lines with the ellipse.

43. *Given: Ratio of connecting rod to crank. Valve to be a plain D valve to give equal leads of known amount. Valve motion practically harmonic. Head-end steam lap known, valve travel known, exhaust laps equal and known.*

To find: Crank-end steam lap, and per cent of stroke at which cut-off, release and compression occur.

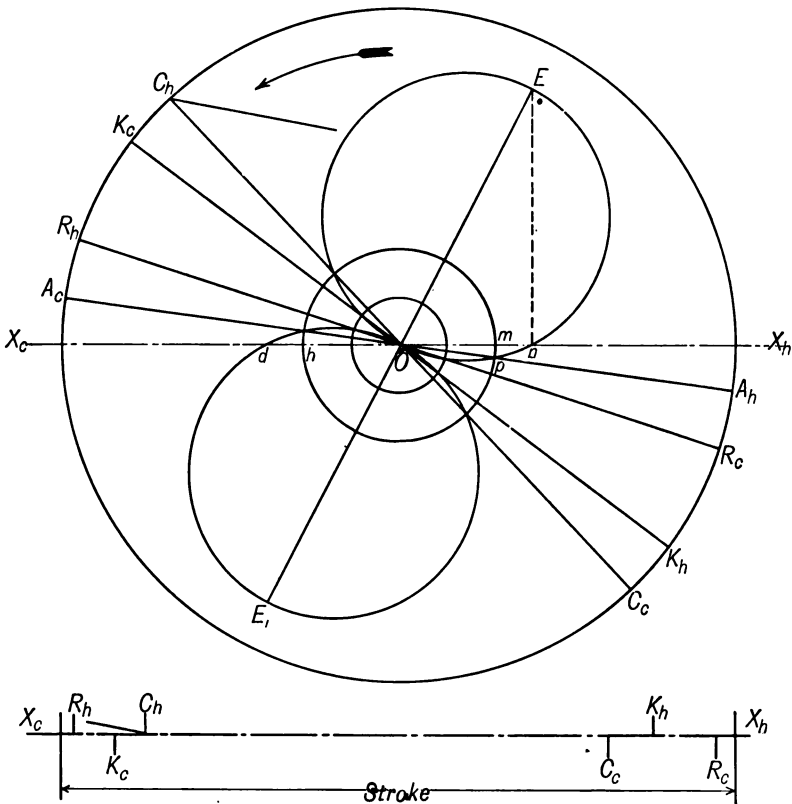

FIG. 59.

Since the valve motion may be assumed harmonic, either Zeuner's, Reuleaux or Bilgram diagrams may be used. We will work by both the Zeuner's and Reuleaux diagrams. Referring to Fig. 59 draw the line $X_c X_h$ as the center line of the engine, and, choosing point O as the center of the crank shaft, draw the crank-pin circle at any convenient

scale. In this figure as in the succeeding ones the stroke of the crosshead pin is reproduced directly under the crank-pin circle to save space, although in actually making the drawing it was drawn in its proper position on the line X_cX_h produced as shown in Fig. 3. About O as a center draw a circle with radius equal to the head-end steam lap. From the point m where this cuts X_cX_h lay off mn equal to the given head-end lead. From n erect a perpendicular to X_cX_h and from O with a radius equal to one half the valve travel cut this perpendicular at E . Then OE is the diameter of the upper valve circle for the Zeuner's diagram. Produce EO to E_1 , making $OE_1 = OE$. On these two lines draw the valve circles. The lines OA_h and OC_h drawn through the intersections of the head-end steam-lap circle with the upper valve circle show the crank positions for head-end admission and cut-off respectively. Since the crank-end lead was given as equal to the head-end lead the crank-end steam lap must be equal to the head-end steam lap. This is evident from the geometry of the figure. About O draw a circle with radius equal to the given exhaust laps (which were assumed to be equal). When the crank is at OK_h , drawn through the intersection of the exhaust-lap circle with the lower valve circle, the valve is displaced toward the head end an amount equal to the head-end exhaust lap, and is moving toward the crank end. Therefore head-end compression is beginning at OK_h . When the crank reaches OR_e the valve is displaced toward the crank end an amount equal to the crank-end exhaust lap and is moving toward the crank end. Therefore crank-end release is occurring. Similarly, when the crank is at OK_e the valve is displaced toward the crank end an amount equal to the crank-end exhaust lap and is moving toward the head end, therefore crank-end compression is beginning; and at OR_h the valve is displaced toward the head end an amount equal to the head-end exhaust lap and is moving toward the head end so that head-end release is occurring. The crosshead positions corresponding to these several crank positions are found in percentages of the stroke as described in § 6. These are shown on the stroke line in Fig. 59.

Fig. 60 is the solution of the same problem by means of the Reuleaux diagram. The crank-pin circle is drawn as above described. About O is drawn the eccentric circle with radius equal to one half the valve travel. From O with radius Om equal to head-end steam lap plus head-end lead an arc is drawn, and through t , where the eccentric circle cuts X_cX_h , a line is drawn tangent to this arc. EOE_1 drawn perpendicular to this line is the reference line of the Reuleaux diagram. Lay off Op equal

to the head-end steam lap. Then a line through p perpendicular to EOE_1 will intersect the eccentric circle at V and W , and OA_h and OC_h drawn through V and W respectively give the crank position for head-end admission and cut-off. OZ and OS being made equal to the head-end

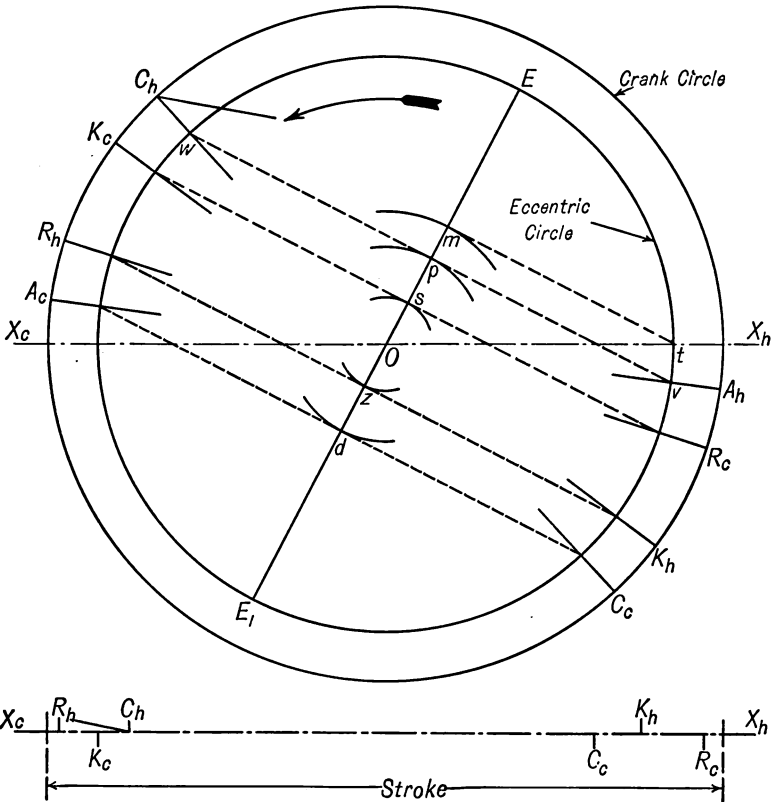

FIG. 60.

and crank-end exhaust laps respectively give the points through which to draw perpendiculars to EOE_1 to find the crank positions for release and compression.

An inspection of the stroke lines in Figs. 59 and 60 indicates that the cut-offs are unequal, showing the truth of statement 1 under § 28.

44. Given: Ratio of connecting rod to crank. D valve with harmonic motion. Valve travel known; cut-offs equal and percentage known; crank-end lead known; compressions equal and percentage known.

To find: Steam and exhaust laps, head-end lead, percentage stroke for releases.

Referring to Fig. 61, the crank circle is drawn and the stroke line laid off as before; the eccentric circle is also drawn with radius equal to half the valve travel. With center t where the eccentric circle cuts the crank end of $X_c X_h$ draw a circle with radius equal to the crank-end lead. Find crank positions OC_c for crank-end cut-off and OC_h for head-end cut-off. From M where OC_c cuts the eccentric circle draw a line tangent to the

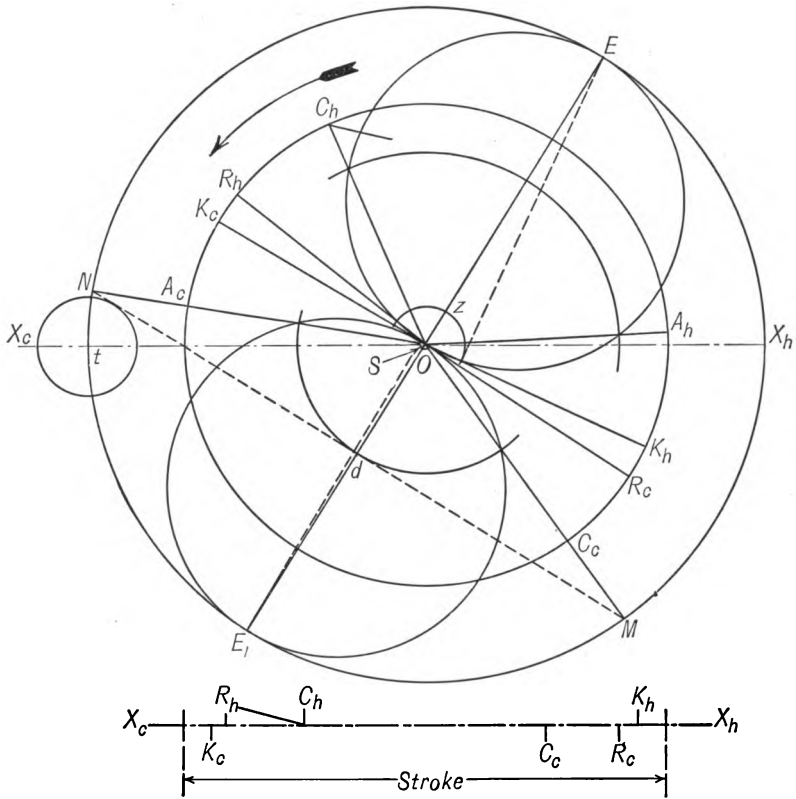

FIG. 61.

lead circle cutting the eccentric circle at N . Then ON will give the crank positions for crank-end admission and E_1OE perpendicular to MN will be the valve circle diameters. Od will be the crank-end steam lap. The correctness of this construction can be understood by thinking of its similarity to the Reuleaux diagram. The valve circles are next drawn and from OC_h the head-end steam lap and therefore head-end lead are found. The crank positions for the equal compressions may now be constructed,

45. Fig. 63 is the solution by means of Zeuner's diagram and Fig. 64 is the solution by the Reuleaux diagram of a problem in which the data is the same as in § 44 except that the leads are made equal and both exhaust laps are taken as zero. This brings out no new point but shows again the effect which equal laps have on the equality of the cut-off

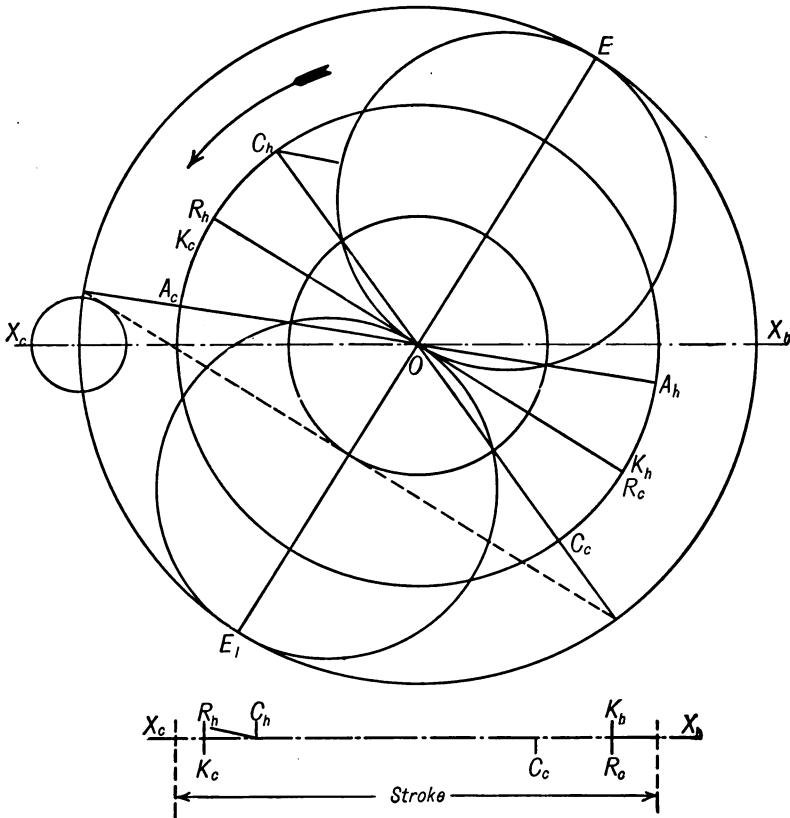

FIG. 63.

and compression. It is also evident that with zero exhaust laps all exhaust events occur when the valve is in mid-position.

46. *Given: Piston valve taking steam at the middle, direct connected; valve travel, lead and angle between crank and eccentric known; compressions equal at known percentage of stroke. To find the steam and exhaust laps and the per cent stroke of cut-offs and releases.*

Since with a piston valve taking steam at the middle the eccentric will be placed relative to the crank as shown in Fig. 45a the angle X_1OE ,

Fig. 65, will be made equal to the angle between crank and eccentric (see § 36). On the line EOE_1 thus found draw the two valve circles with diameters equal to one half the known travel. In the figure the scale happens to be such that the length of the stroke line on the draw-

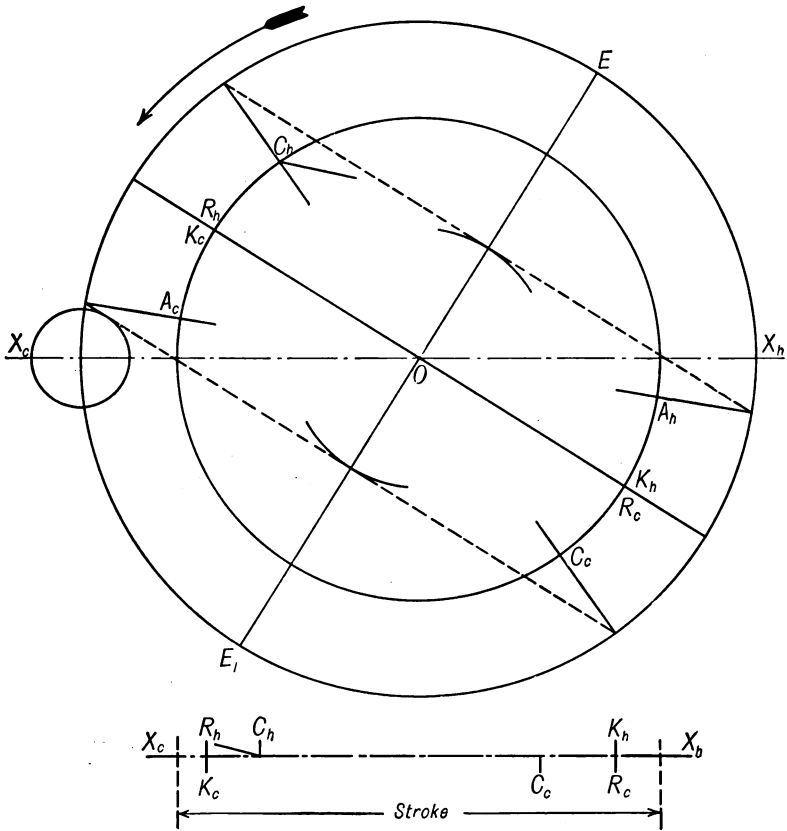

FIG. 64.

ing appears the same as the valve travel. This is, of course, not actually the case, as the valve dimensions are drawn full size while the crank-pin circle is at a much reduced scale. Since we are dealing with a piston valve where the inside laps are the steam laps the upper valve circle represents valve displacements toward the head end and the lower, toward the crank end. The distance On indicates the amount the valve is displaced when the crank is on the head-end dead point. From n measure in the distance nm equal to the known head-end lead, then Om

is the head-end steam lap. In a similar way measure in from d the distance dh equal to the crank-end lead and Oh is the crank-end steam lap. Knowing the steam laps, the crank positions for admission and cut-off and the per cent stroke for cut-offs can be found. Since the

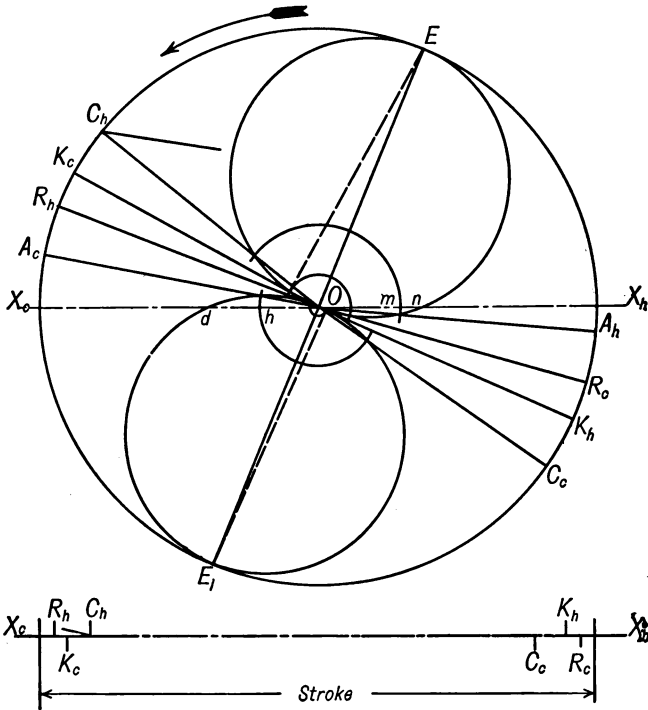

FIG. 65.

percentages at which the compressions occur are known the crank positions corresponding are found in the usual way and from these the exhaust laps are determined and then the releases. In this case both exhaust laps happen to be positive but the head-end lap is much the smaller, being nearly zero.

Fig. 66 is the Reuleaux diagram for the same problem.

47. Short Cut-off at Expense of Other Events. In the preceding examples the data has been so chosen that the cut-off was fairly late in the stroke. An engine running under normal load gives more economical results with a short cut-off. A single valve cannot be designed to give short cut-off without sacrificing on release or compression or both.

Fig. 67 is a Reuleaux diagram for a slide valve, giving a small lead, and equalizing cut-off at $\frac{1}{2}$ stroke. In order to obtain this cut-off the eccentric must be set at a large angle ahead of the crank with the result that release and compression are both very early. The release might

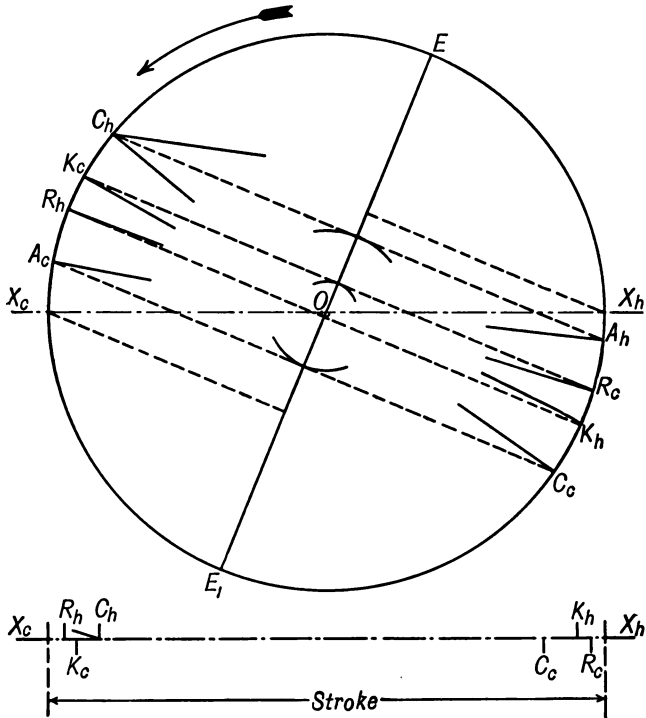

FIG. 66.

be made later by decreasing the exhaust clearance, but that would make the compression still earlier.

Fig. 68 is an indicator card which shows about what the steam distribution would be under the conditions of Fig. 67.

48. Port Calculations and Valve Layout. In the design of a slide valve for a certain engine the laps are determined by some method similar to the ones illustrated in the preceding examples. The total length of the valve must be determined by laying out a longitudinal section in which the ports, bridges, etc., are proportioned and located to give proper action. The first step in this work is to determine the proper width of port to supply steam to and exhaust it from the engine

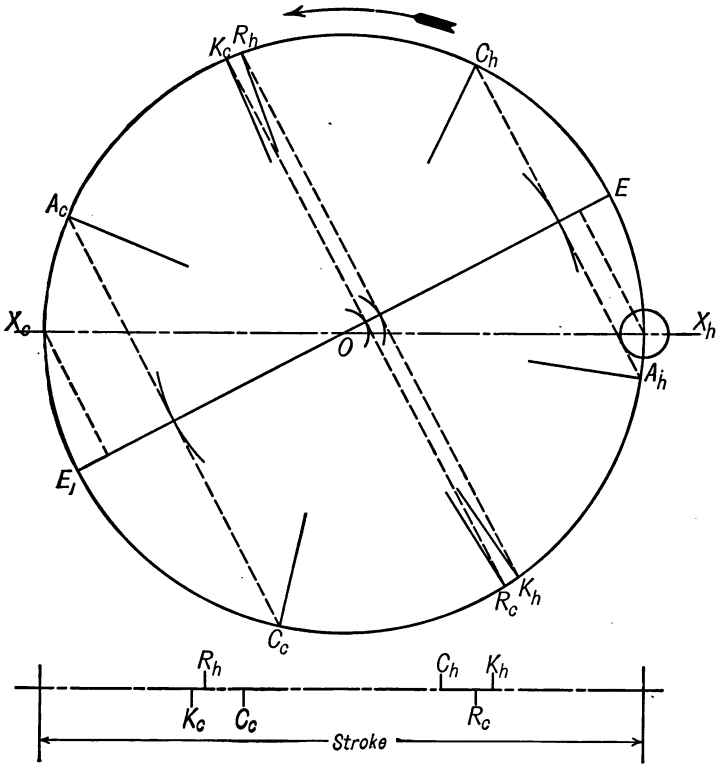

FIG. 67.

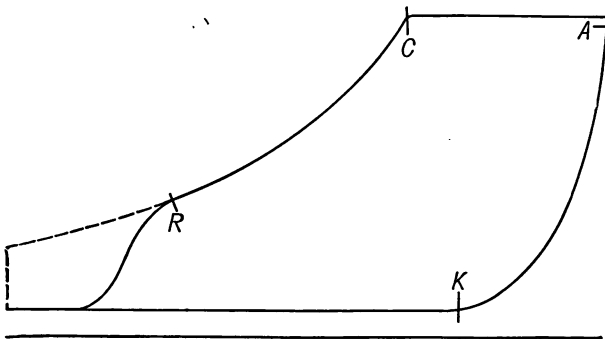

FIG. 68.

in question. The following method will serve as a guide in selecting a suitable width of port.

First decide upon the average velocity of the steam flow. This may be taken as 6000 feet per minute for live steam and 4000 feet per minute

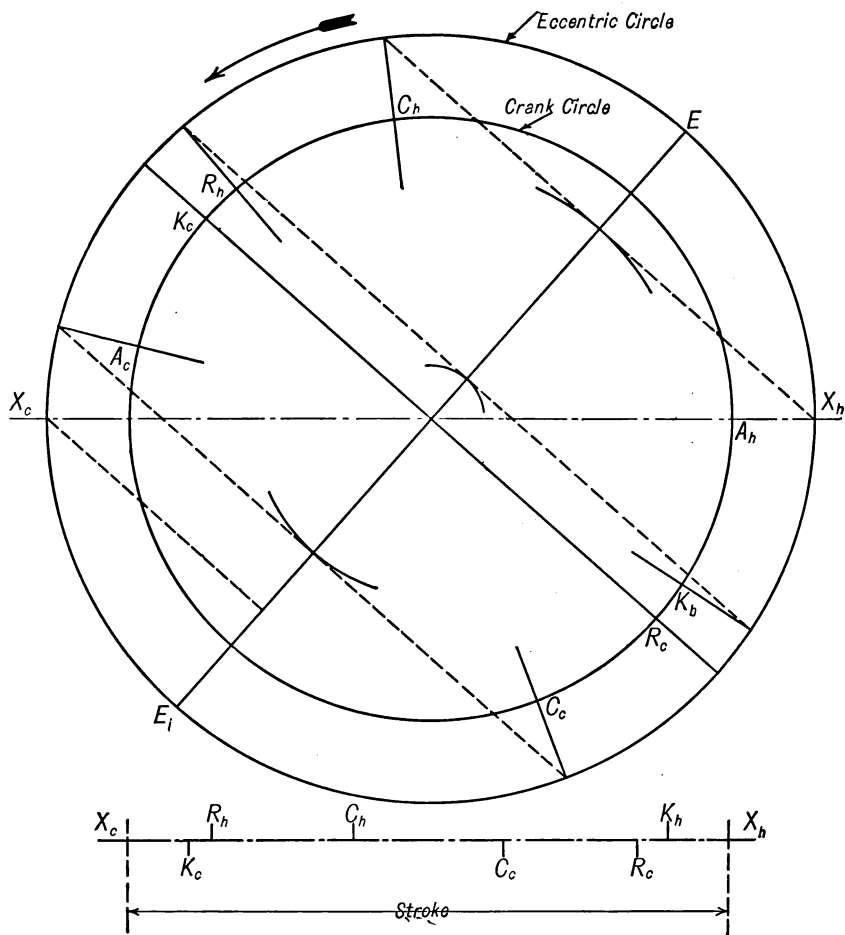
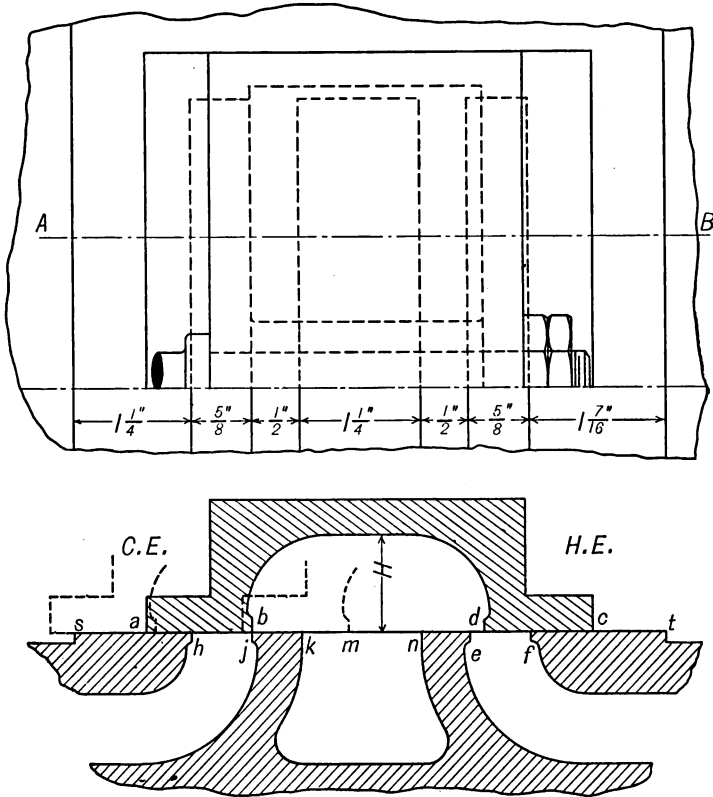

FIG. 69.

for exhaust steam. These figures are conservative, much higher average velocities being often allowed. It is assumed that the rate of flow through the ports is such that the cylinder would be filled twice in each revolution if steam flowed in during the full stroke. The cubic feet of steam required per minute in the cylinder would be $V = \text{piston area in square feet} \times \text{stroke in feet} \times \text{revolutions per minute} \times 2$.

Then $V \div$ average velocity of live steam $\times 144$ will be the port area in square inches necessary for admitting steam and $V \div$ average velocity of exhaust steam $\times 144$ will be the port area in square inches necessary for exhaust steam.



Section on A B

FIG. 70.

Since the exhaust steam will require the greater area the port will be calculated for the exhaust and will then be ample for live steam.

The length of the port will usually be somewhat less than the diameter of the cylinder bore and for purposes of the port calculation it may be assumed to be three-fourths of the bore diameter. The width of the port will then be equal to the port area divided by port length.

In laying out the valve and a section of its seat, Fig. 70, we will assume that sufficient information is at hand to draw the diagram, Fig. 69. From this the laps and travel will be taken in constructing Fig. 70.

Draw the line representing the surface of the valve seat and lay off at a convenient place hj , the port width as calculated by the method above explained. It is better to start with the port which has the greater exhaust lap. From Fig. 69 this is seen to be the crank end. The crank-end steam and exhaust laps are now laid off from h and j (in this case the exhaust lap is zero) giving the valve edges a and b . Next, choose a width of bridge jk which will be practicable for strength and test to see that the edge a of the valve never moves onto the bridge far enough to allow leakage past it into the exhaust. In the figure the edge a does not run onto the bridge when it has its greatest displacement, as shown by the dotted line. In some cases it might, hence the necessity for the above test. The width of the exhaust cavity kn is found by making the distance mn , between the inside edge of the valve when it has its greatest displacement, and the nearer edge of the head-end bridge, equal to or a little greater than the port width. Make the head-end trial width of the bridge equal to the width of the crank-end bridge, lay off the width of the port ef and lay off the head-end steam and exhaust laps. Now test to see that steam cannot flow past edge c into the exhaust. If it does the bridge ne must be made thicker. The height of the exhaust cavity H is more or less arbitrary. It may be made a little greater than the width of the port.

In order that the edges of the valve may overtravel the seat and thus wear more evenly the seat is cut down from the points s and t , the amount of overtravel being $\frac{1}{8}$ inch or more.

CHAPTER V

GOVERNING DEVICES FOR SINGLE-VALVE ENGINES

49. An engine is designed to develop a certain power and when developing this power it may be said to be running under normal load. The load on any engine is likely to vary, however, over a wide range. This variation must be met by a corresponding change in the steam supply; that is, if the engine has less than its normal amount of work to do either less steam must be supplied in a given time, or else the steam must be supplied at a lower pressure. In locomotives, marine engines and the like, the steam supply is adjusted to the demand by the attendant. Stationary engines are usually expected to run at a practically constant speed and to maintain this speed by automatically regulating their own steam supply. The devices by means of which such regulation is accomplished are called governors. It is our purpose in the present chapter to consider the principles of some of these governing mechanisms and the way in which different types of governors affect the steam distribution.

Reference has already been made to the indicator card as a means of showing how the steam is distributed and as a measure of the work which the engine is doing. We shall make use of the indicator card as a basis for comparing the action of the various governors discussed.

For purposes of this discussion we shall deal principally with the head end of the cylinder, bearing in mind that the same considerations apply to both ends.

In Fig. 12 the area $EBCRD$ is a measure of the work done by the steam during the forward stroke. Similarly the cross-hatched area represents the work done on the steam during the return stroke. The difference of these areas, that is, the area enclosed by the card $ABCRK$, represents the net work done on the piston by the steam per revolution in one end of the cylinder. Evidently, if the speed of the engine remains constant the power will be increased by increasing the area of the card and decreased by decreasing the area.

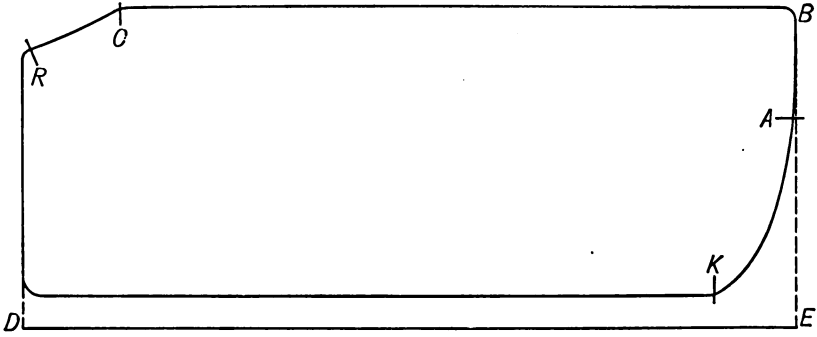

FIG. 71.

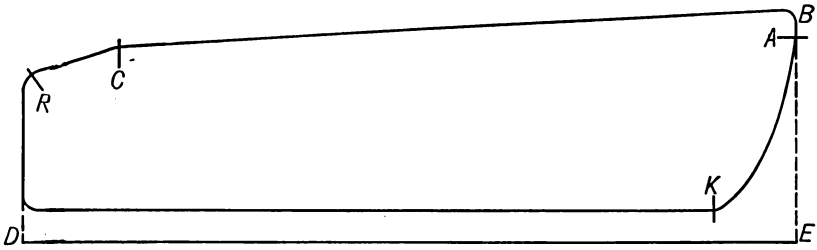

FIG. 72.

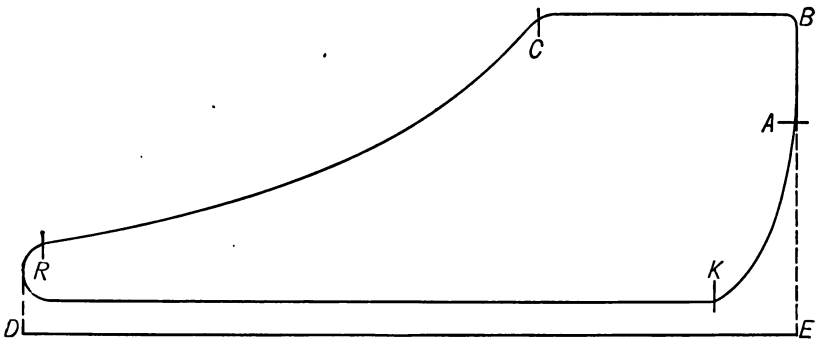

FIG. 73.

The purpose of the various governing devices is to change the area of the card as the load on the engine varies, the change of area being such that the speed will remain practically constant.

Fig. 71 is a card representing the conditions when the engine is carrying a full load, the cut-off being very late. If now, the load is partly removed from the engine so that the work done on the head end, instead of requiring a card as in Fig. 71, requires a card of less area, this area may be reduced in one of two ways.

50. Throttling Governors. One of these ways is by "throttling" the steam supply, keeping the cut-off the same. Fig. 72 shows the card for such a condition and Fig. 74 shows a throttling governor such as might be used to accomplish the result. The operation of the governor is as follows: The pulley *K* is belted to the engine shaft, and, by means of the shaft *S*, sleeve *T* and the connecting bevel gears, causes the balls *B* to revolve about a vertical axis. Centrifugal force causes the balls to fly out and the levers *L* force the shaft *M* downward partially closing the valve *A*, through which the steam must pass to reach the steam chest.

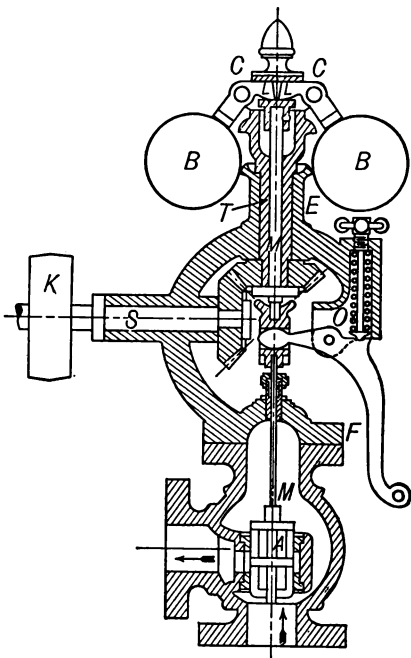

FIG. 74.

51. Flywheel Governors. The second method for reducing the area is by causing the valve to cut-off earlier, as represented in Fig. 73, where the area is practically the same as in Fig. 72, but the pressure of the steam during admission is the same as in Fig. 71. While it is not possible at this time to go into a discussion of the relative advantages of the two cards (Figs. 72 and 73) attention might be called to the fact that in Fig. 72 the steam begins to exhaust at a relatively high pressure, whereas in Fig. 73 the steam expands down to a much lower point before being sent out of the cylinder.

In making these cards it has been assumed that all the events of the

stroke have remained unchanged except cut-off. With a single valve, however, this would be impossible, as any change in the eccentric which would vary the cut-off would also vary the lead and the release and the compression. What follows in this chapter applies to single-valve engines with single eccentric. Later we shall consider control of steam by other types of valves and valve gear. Governing devices which vary the cut-off with a single valve are attached to the flywheel and their operation depends upon the centrifugal action of heavy weights opposed to springs. As the engine speeds up the centrifugal force increases, overcoming the spring pressure, and the weights move out. In doing so they shift the position of the eccentric on the shaft by means of links.

The eccentric may be shifted as follows:

1. Angle between crank and eccentric may be changed.
2. Eccentricity may be changed.
3. Both the angle and eccentricity may be changed simultaneously.

The first two cases are almost never employed with a single valve, but it may be well to notice what the effect would be if the governing were done in this way.

52. Changing Angle between Crank and Eccentric. In Fig. 75 the circle whose diameter is OE is the valve circle when the eccentric is set for latest cut-off, the indicator card being the same as that shown in Fig. 71. If now the load were to go off so that the engine started to speed up the governor would swing the eccentric around on the shaft, to a position represented by the circle on the line OE_1 . The cut-off would thus be shortened to a crank position OC_1 which, of course, is working in the right direction; but, at the same time, the lead has been made excessive, and release and compression have been made too early. Fig. 76 shows a card illustrating the conditions resulting from such a change. It is evident from this that, while cut-off is shortened and the area of the card is reduced, the cross-hatched area which represents work done on the steam by the piston, also the area under the dotted curve which represents work that might have been obtained from the steam with a late release, are both large, indicating an unsatisfactory performance.

53. Changing Eccentricity. A change in cut-off might be accomplished by reducing the eccentricity, keeping the angle between crank and eccentric constant. Such a method would be subject to objections similar to those for changing the angle and, furthermore, would not be quite as simple to accomplish mechanically.

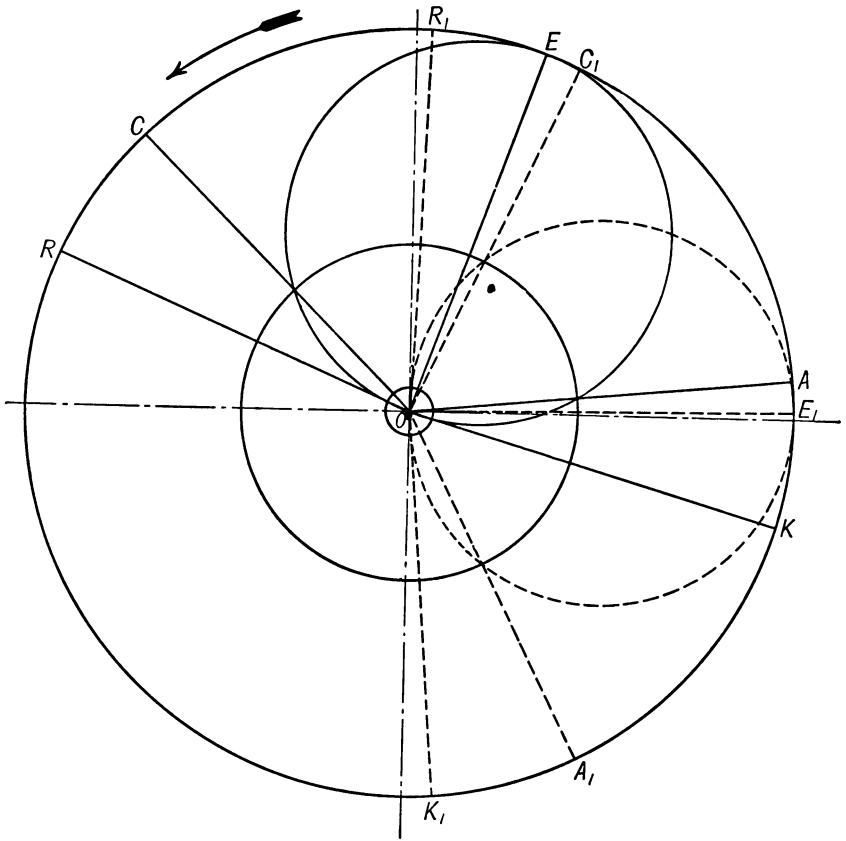

FIG. 75.

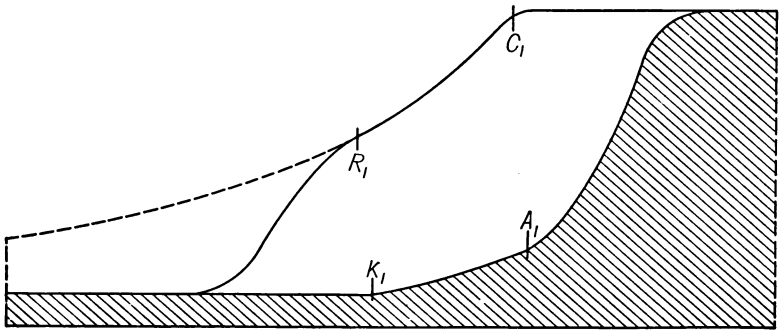

FIG. 76.

54. Changing Both Eccentricity and Angle between Crank and Eccentric. Practically all flywheel governors are arranged in such a way that when the engine speed increases the angle between the crank and eccentric is changed and the eccentricity is changed at the same time. Fig. 77 is a line drawing of such a governor of simple construction. The eccentric instead of being attached directly to the shaft is pivoted

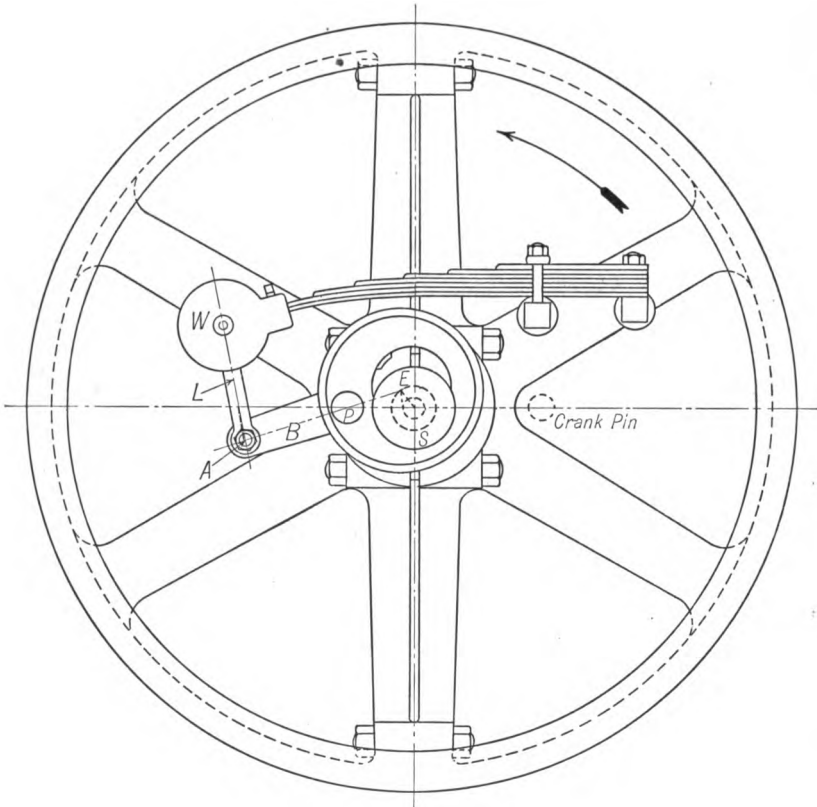

FIG. 77.

to the flywheel by the pin P . The arm B is fast to the eccentric. By means of the pin A and link L the arm B is connected to the governor weight W which is fast to the end of the spring. In the position shown the center of the eccentric is at E . As the speed of the engine increases W swings out from the center, causing A to swing up in an arc of a circle relative to P , thus swinging E down in an arc relative to P . The

effect of this movement is, of course, to increase the angle between crank and eccentric and decrease the eccentricity.

The location of the point of support P relative to the crank pin has a very important influence upon the way in which the governor controls the steam distribution, the effect on the lead being particularly noticeable. P may be located on a line passing through the center of the crank pin and the center of the shaft, as is the case in Fig. 77, or it may be off this line. Furthermore, the location of the pivot point P determines whether the lead shall increase, decrease or remain practically constant when the cut-off is shortened.

For purposes of discussion we will assume, for the present, that the point of support is on the line through the center of the crank pin and shaft or that some other means of guiding the eccentric is used which is equivalent to swinging it about a point on this line. We have, then, three cases to consider as follows:

1. Lead increasing as cut-off shortens.
2. Lead decreasing as cut-off shortens.
3. Lead remaining constant as cut-off shortens.

55. Increasing Lead. Fig. 78 shows how the eccentric would be supported relative to the crank pin to produce increasing lead as the cut-off shortens. If the arc on which the center of the eccentric moves is *concave* toward the shaft the lead will always increase as the cut-off shortens. In Fig. 78 it is assumed that the valve takes steam on the outside and is driven direct from the eccentric rod. Fig. 79 is the Zeuner's diagram for this eccentric. The full valve circle corresponds to the eccentric with center at E (Fig. 78), giving late cut-off; this gives zero lead, cut-off at OC (Fig. 79), release at OR and compression at OK . The dotted valve circle is for the eccentric center shifted to E_1 (Fig. 78), giving a large lead, cut-off at OC_1 , release at OR_1 (very early) and compression at OK_1 (excessive). The card for this is shown in Fig. 80, and it is evident that the area representing lost work is large.

A serious objection to a governor which gives an increase of lead is that it will never entirely shut off the steam supply, however far the eccentric swings and, consequently, cannot be depended upon to prevent the engine "running away." This type of governor is rarely, if ever, used.

56. Decreasing Lead. Fig. 81 shows an eccentric so guided that the lead decreases from an amount AB when set for latest cut-off to zero when swung down so that it is 180 degrees ahead of the crank. It is

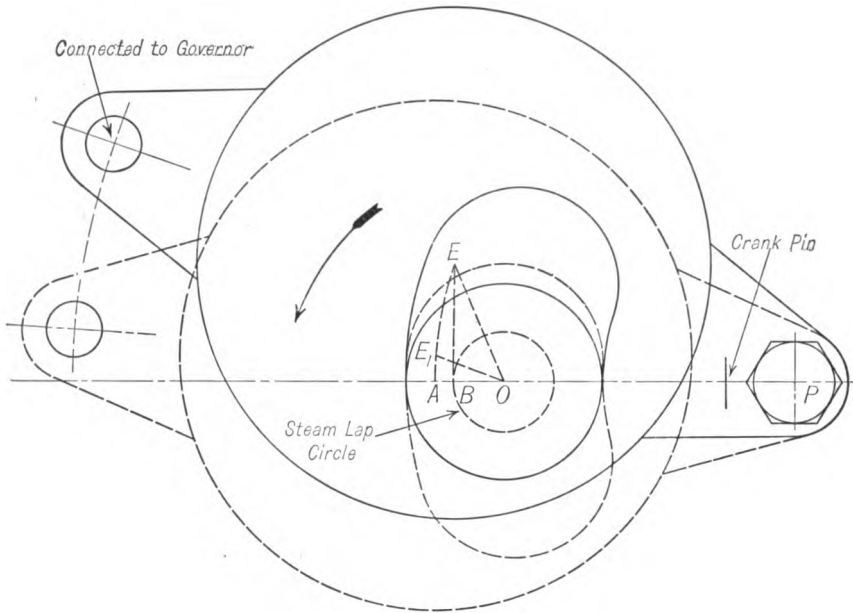

FIG. 78.

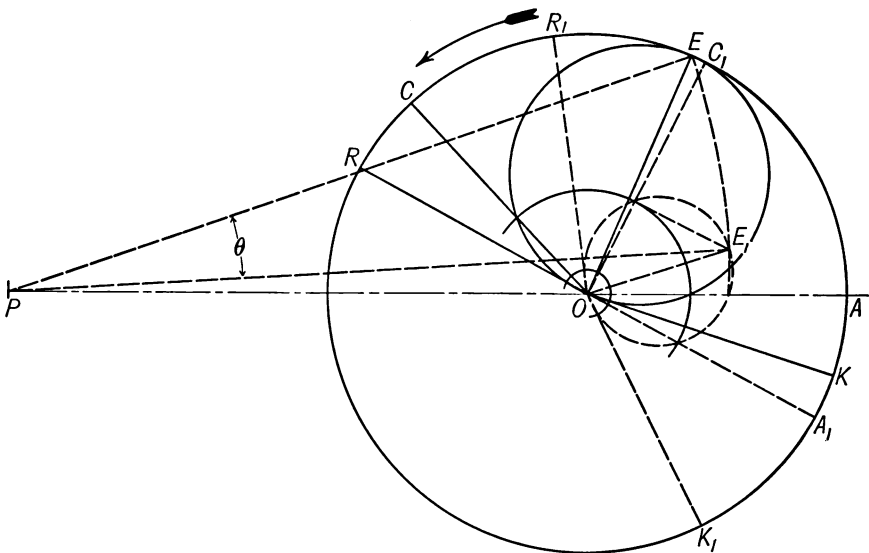

FIG. 79.

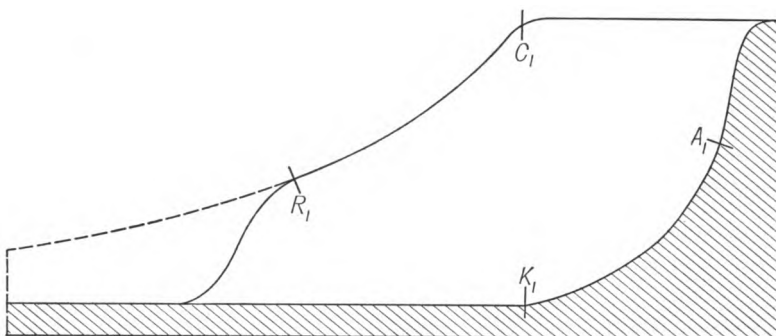

FIG. 80.

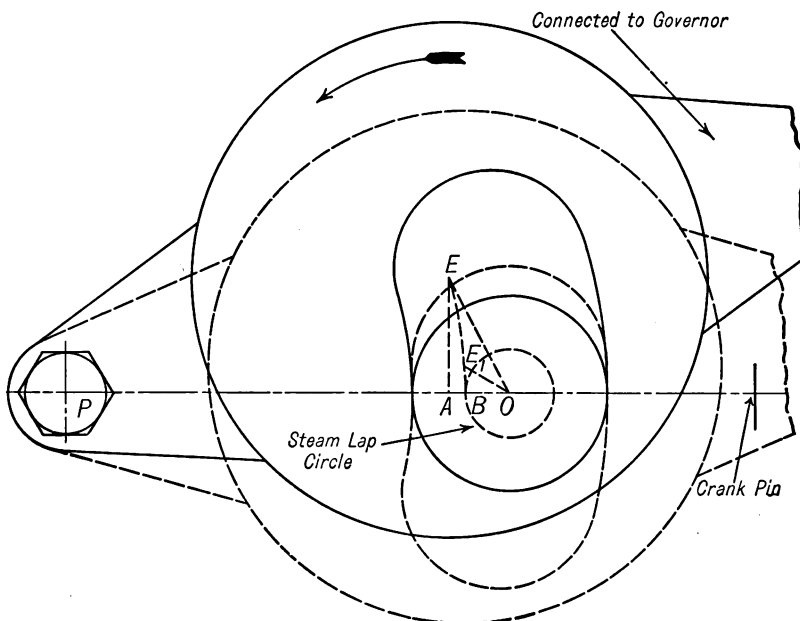

FIG. 81.

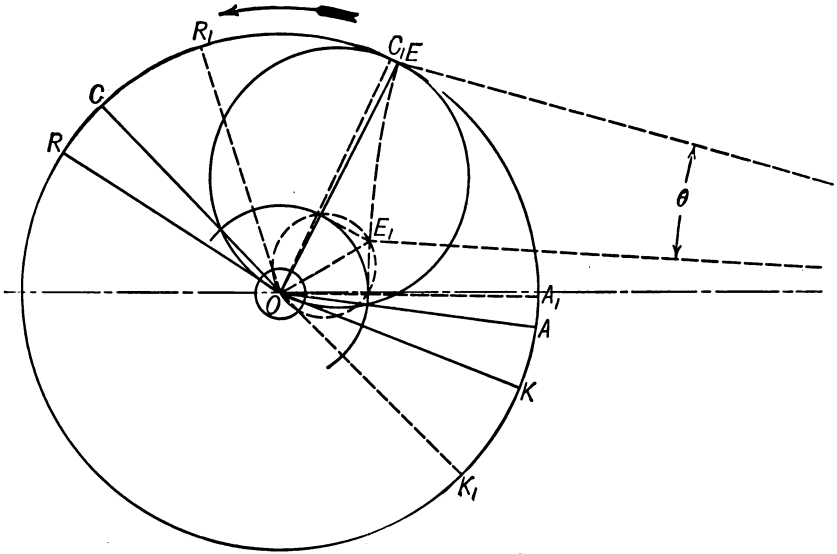

FIG. 82.

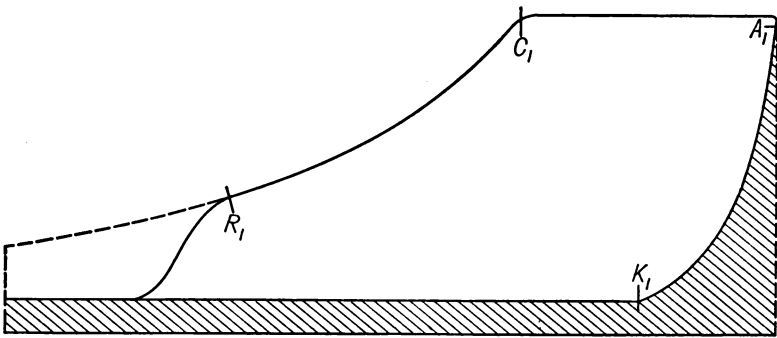

FIG. 83.

to be noted that the arc over which the eccentric center moves is now *convex* toward the shaft and such a condition will always give decreasing lead with shortening cut-off if the point of support is on the center line through crank pin and shaft.

Fig. 82 is the Zeuner's diagram and Fig. 83 is the card corresponding to the position of the eccentric E_1 . The position of the crank and piston for the different events is evident from the diagram and from the card. While there is still a considerable area on the card representing lost work the conditions are better than in Fig. 80. Furthermore when the eccentric is shifted to the limit the port is never opened and the engine can get no steam. This is an extremely important feature from the standpoint of safety especially with a condensing engine. The governor shown in Fig. 77 is of this type.

57. Constant Lead. If the point of support is kept on the center line of the crank but is carried farther from the center of the shaft the arc over which the center of the eccentric moves becomes flatter and the lead will be changed less for a given change of cut-off. If a method is used for guiding the eccentric, which is equivalent to swinging it about a point on the center line of the crank at an infinite distance from the shaft, then the path over which the center of the eccentric moves relative to the crank pin, when the cut-off is changed, is a straight line perpendicular to the center line of the crank. This means that the lead will remain unchanged. Fig. 84 shows such an eccentric (the guiding mechanism being omitted). Fig. 85 is the Zeuner's diagram for the same. A form of governor which moves the eccentric in this way will be shown later in connection with a four-valve engine. (Fig. 127.)

58. Valve Driven Through a Rocker. The foregoing cases have all assumed that the valve was direct connected and that the point of support was on the center line of the crank either at some finite distance or at infinity. If the path of motion of the valve is not parallel to that of the piston or if the valve is driven through a bent rocker, such as shown in Fig. 10, then in order to obtain the equivalent of the above conditions a special construction would have to be made to find the point of support.

59. Point of Support Not on the Center Line of Crank. It is not uncommon to find the point of support at one side of the center line of the crank with direct connection to the valve. This is shown in the Zeuner's diagram, Fig. 86. It is to be noted here that the full gear lead is small while the "mid-gear" lead is zero. When the cut-off begins to

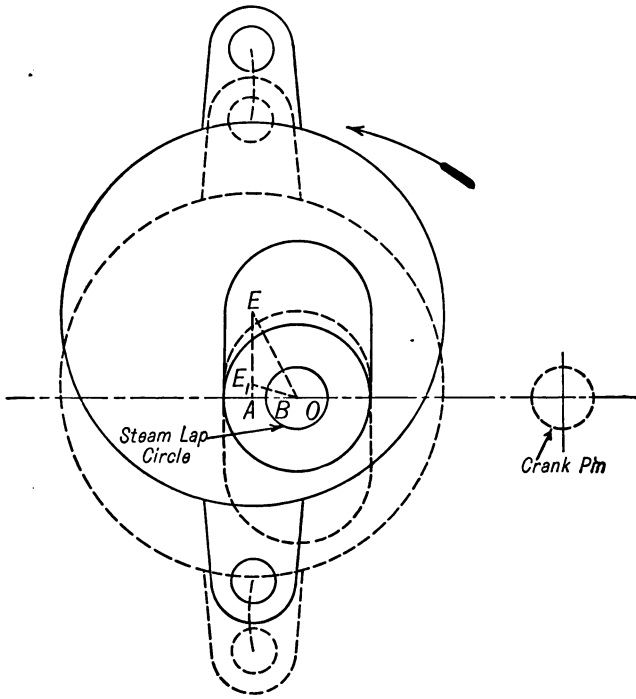

FIG. 84.

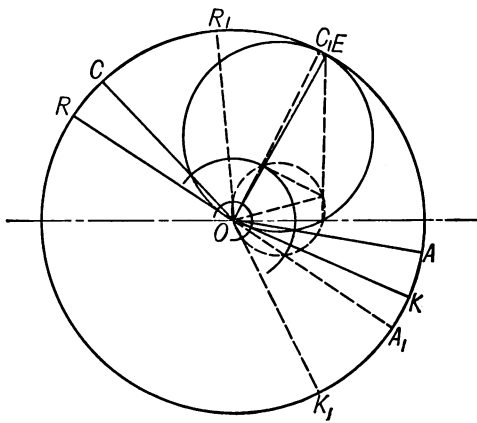

FIG. 85.

decrease the lead increases for a time, then decreases, so that the valve does not open the port at all when the eccentric is 180° with the crank. This diagram is for the governor shown in Fig. 87. Another fact to be

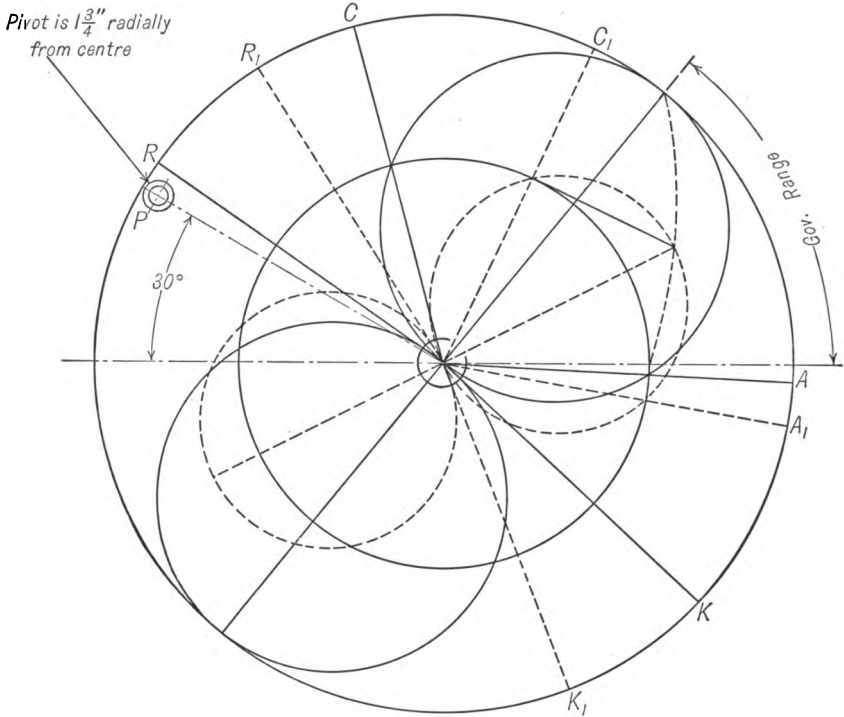

FIG. 86.

noticed here is that no eccentric is used, the eccentric being replaced by a pin attached to the governor arm. The pin *E*, of course, revolves about the center of the shaft when the wheel turns and drives the eccentric rod in the same way as would an eccentric whose center was at *E*. This is an advantage on a high-speed engine since an eccentric running at high speed is liable to cause trouble. The position of the short heavy arm which carries the pin *E* is controlled by the outer weight arm through the short link. As the speed increases the outer arm swings relative to the flywheel and in turn swings the eccentric arm about *P*, thus changing the position of *E* relative to the center of the shaft and crank.

60. Inertia Governors. No governors which depend solely upon centrifugal force for their operation can be very sensitive because in order to cause the weights to move out the speed must increase an

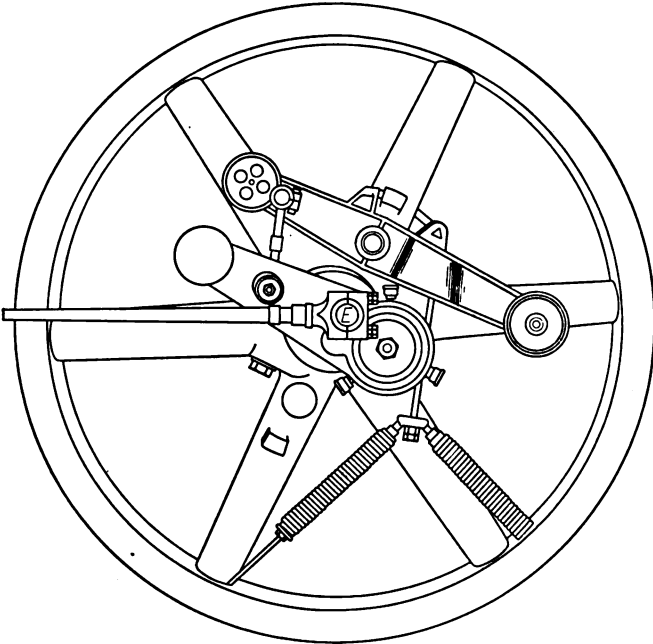

FIG. 87. Governor for American-Ball Engine.

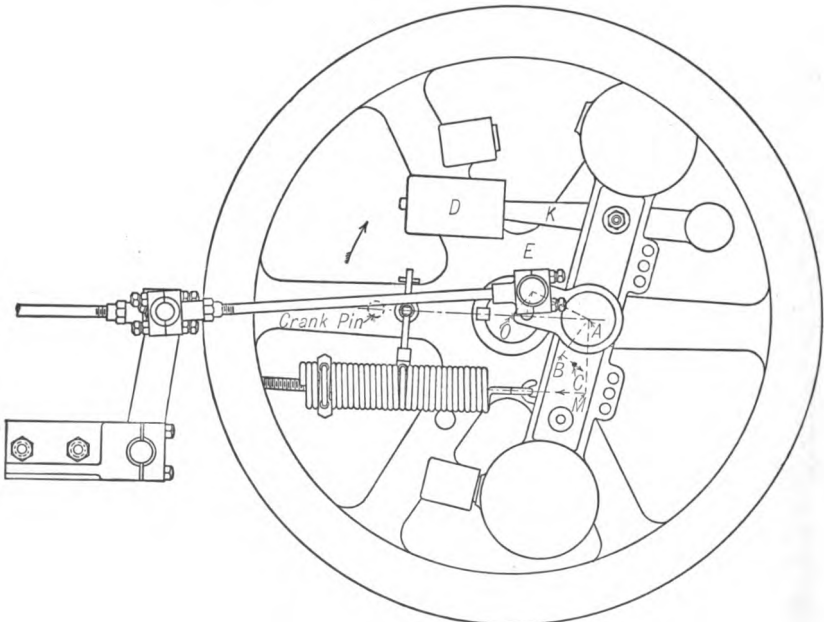

FIG. 88. Governor for Ridgway Engine.

appreciable amount. The governor shown in Fig. 88 (also shown in Fig. 18) belongs to a class known as inertia governors. In Fig. 88 the centrifugal force of the weight arm (whose center of gravity is at the point *C*) just balances the force of the spring in any given position when the engine is running at normal speed. This balance is adjusted by changing the initial tension on the spring and by adding or taking away weight from the ends of the weight arm, provision being made for doing this. With the wheel turning as shown by the arrow, the weight is pulled around by the spring. Suppose now that the wheel is turning at the speed for which the mechanism is adjusted. If the load were to suddenly go off so that the wheel started to speed up it would try to speed the weight up with it. The inertia of the weight tends to keep it at its former speed, the result being that the spring is stretched a little; that is, the wheel goes a little ahead of the weight. This is equivalent to swinging the pin *E* in over the dotted arc, relative to the center line of the crank. This pin *E* takes the place of an eccentric, as was the case in the last governor considered. The result, therefore, of the above motion of *E* relative to the center line of the crank is to increase the angle between crank and eccentric and decrease the eccentricity. *D* is a dash-pot whose piston is connected to the governor weight by the rod *K*, its purpose being to steady the action of the weight. This type of governor, on account of its sensitiveness, requires a well-balanced valve which is easily moved.

CHAPTER VI

RIDING CUT-OFF VALVES AND THEIR GOVERNING DEVICES

61. In the discussion of governing devices in Chapter V it was pointed out that the speed of the engine is commonly controlled, under varying loads, by a shaft governor which varies the cut-off. It was also apparent that with a single valve, such as the plain-slide valve, which controls all the events of the stroke, any change in the cut-off is accompanied by a corresponding change in the other events. For example, Fig. 90 shows a card for a cut-off at $\frac{1}{3}$ stroke resulting from a shifting of the eccentric by a shaft governor with a single valve. The release comes when the piston is at M_1 and the compression at N_1 instead of at points near the end of the stroke as in the full gear card, Fig. 89.

It may be very desirable that release and compression, having been determined for a certain engine running at a given speed, shall remain unchanged, whatever the cut-off, as represented by Fig. 91. This can only be accomplished by having the valve which controls the exhaust independent of the governor, and using a separate valve or valves to control the cut-off. Several different kinds of valves are used for this purpose, examples of which will be taken up later. In the present chapter we shall discuss the type known as *riding cut-off valves*, often spoken of as *double valves*.

62. **Cut-off Valve in Separate Chest.** The arrangement formerly used was to provide a double steam chest as indicated by Fig. 92. The outer chest C_1 was supplied with steam from the boiler. This steam in order to get into the real steam chest C was obliged to pass through the passage P_1 . The main valve V was designed to give the desired lead, release, and compression, and a late cut-off. The cut-off valve V_1 was driven by a separate eccentric and was adjusted to close the passage P_1 at the time cut-off was desired, thus shutting off the steam supply even though the main valve had not cut off. The eccentric driving the cut-off valve was controlled by a shaft governor. This arrangement allowed a very limited range through which cut-off could be varied because of

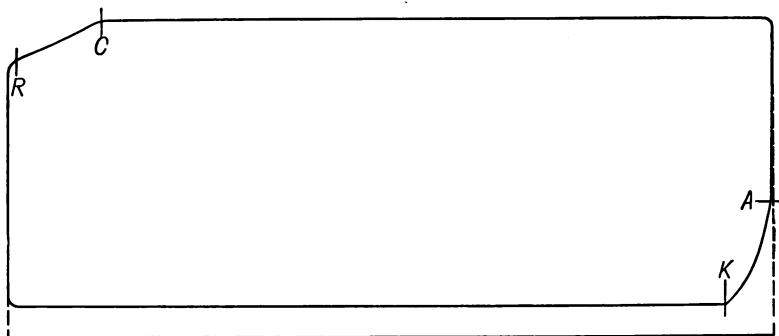

FIG. 89.

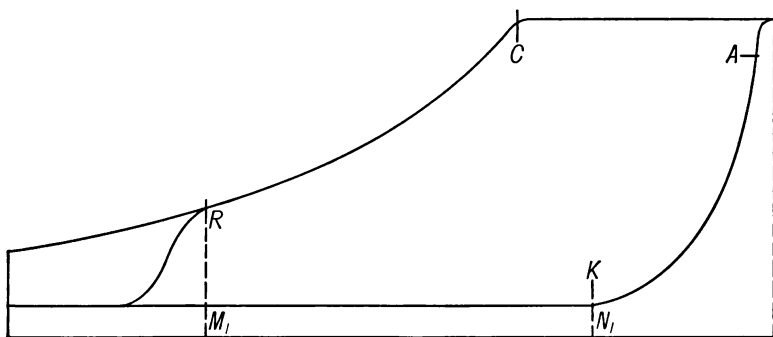

FIG. 90.

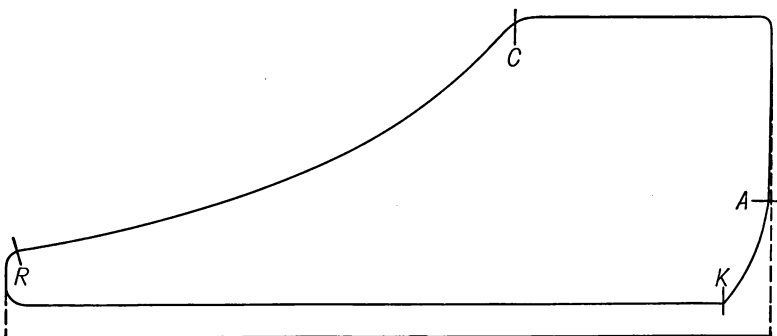

FIG. 91.

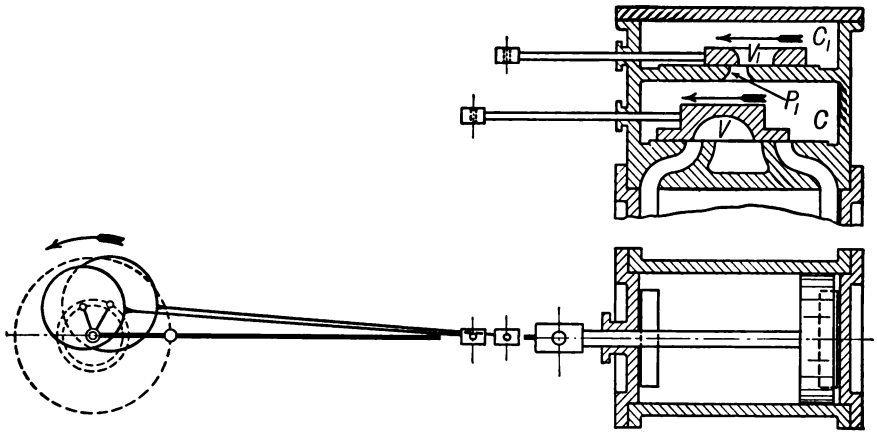

FIG. 92.

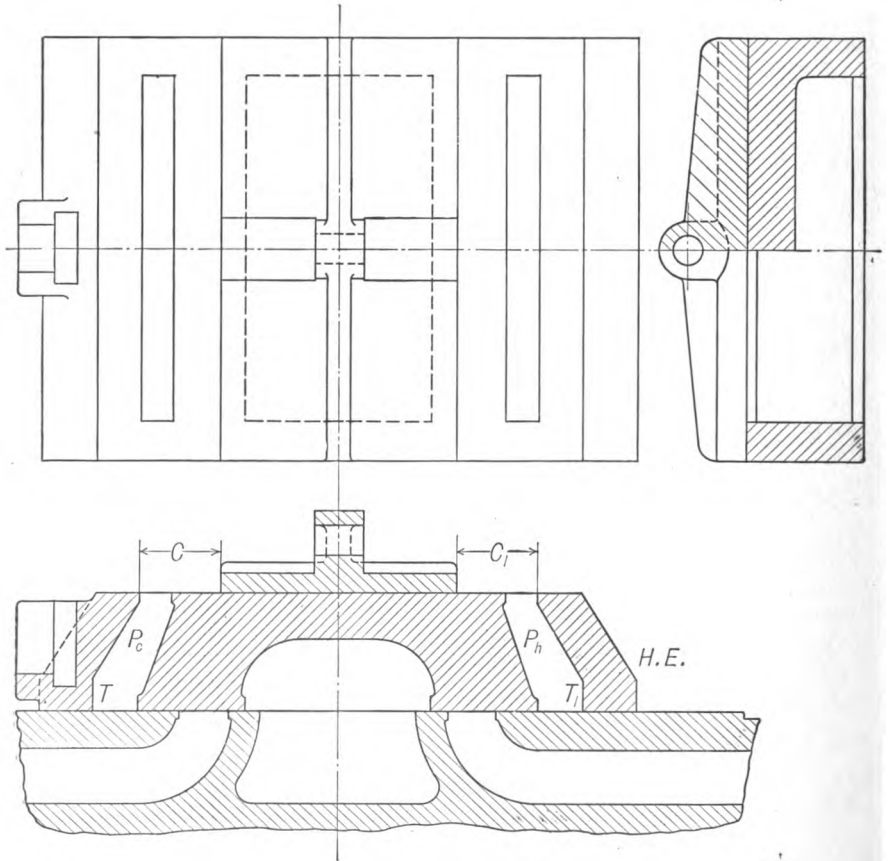

FIG. 93.

the fact that the passage P_1 must be opened before the admission by main valve for the other end of the cylinder.

63. Riding Cut-off Valve. Fig. 93 shows the details of the valves and Fig. 94 shows a diagram of the general arrangement of the whole valve mechanism for a riding cut-off valve. In Fig. 93 the middle portion of the main valve is designed like any slide valve; then the edges T are added so that all steam that goes into the cylinder ports must pass through the passages in the main valve. The riding valve and the eccentric which moves it are so proportioned and adjusted that the riding valve covers the valve port P_h at the time head-end cut-off is

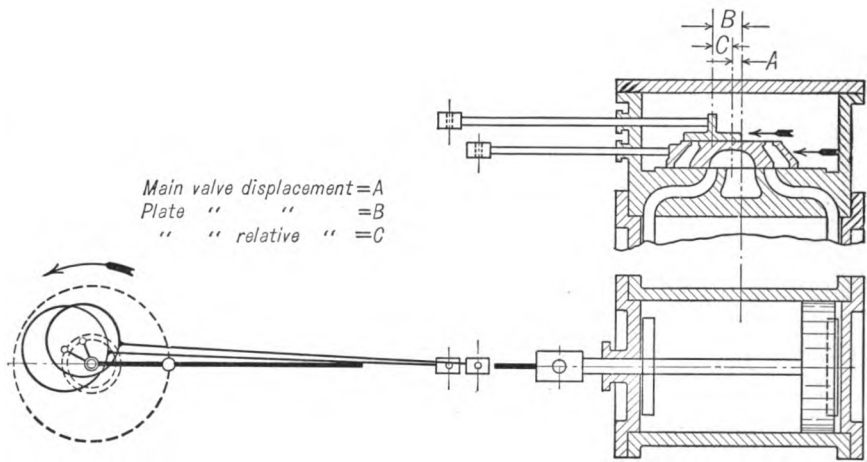

FIG. 94.

desired, and covers the valve port P_c when crank-end cut-off is desired. The riding valve, having closed the valve port for head-end cut-off must keep it closed until the main valve closes the head-end cylinder port else a second admission of live steam to the cylinder will occur on the same stroke. The riding valve eccentric is controlled by a shaft governor which, by shifting the eccentric, causes the riding valve to cover the valve port at a different time. Fig. 93 shows the riding valve in its middle position on the main valve. In this position the right-hand edge of the riding valve is at a distance C_1 , called the *clearance*, from the edge of the head-end valve port. The riding valve must, therefore, be displaced a distance C_1 toward the head end relative to the main valve in order for the head-end valve port to be closed to produce head-end

cut-off. The valves are shown at cut-off in Fig. 95. In Fig. 96 the riding valve is just reopening the head-end valve port. This is called re-admission by the cut-off valve. During the time that the cut-off valve has kept

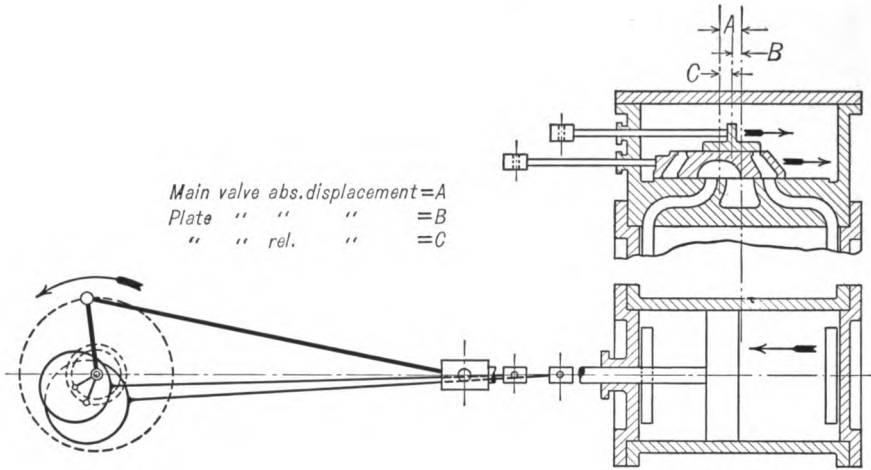

FIG. 95.

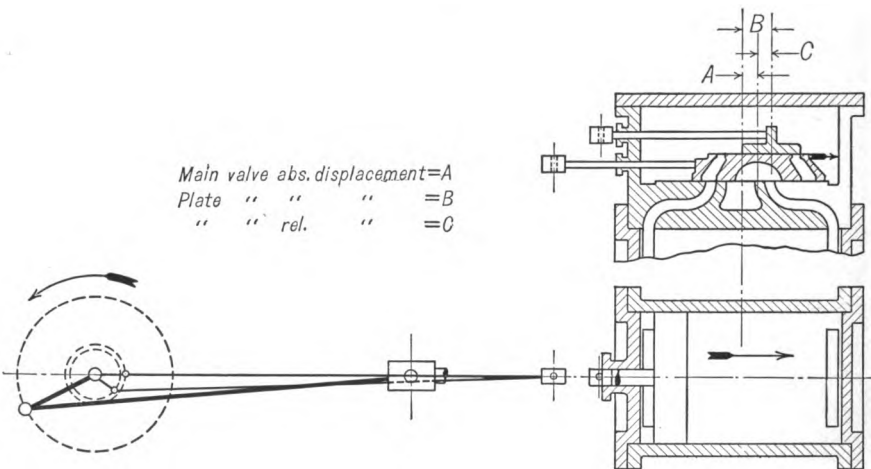

FIG. 96.

the valve port closed, the main valve has closed the head-end cylinder port.

64. Diagram for Riding Valve. An inspection of Figs. 94, 95 and 96 will make it evident that the displacement of the riding valve *relative to the main valve* is the thing which determines the time of cut-off. Accord-

ingly, if a diagram is to be used in connection with the design of a riding cut-off valve such a diagram should show displacements of the riding or "plate" valve *relative* to the main valve as well as absolute displacements of the riding valve. Both the Reuleaux and the Zeuner's diagrams can be constructed to fulfil this purpose. The Zeuner's diagram, however, is somewhat more convenient in this connection and we will therefore use that one.

In Fig. 97 let OC be the crank, E the center of the eccentric which moves the main valve and P the center of the eccentric which moves the riding valve. In the position shown, if both valves have harmonic motion, the main valve is displaced a distance OD toward the crank

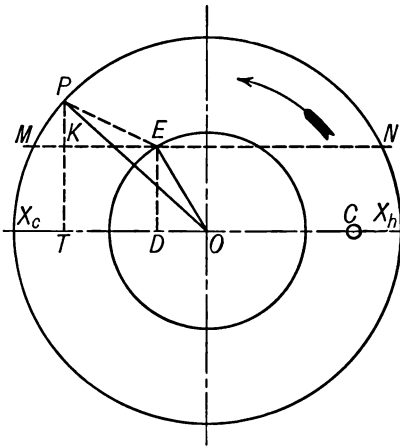

FIG. 97.

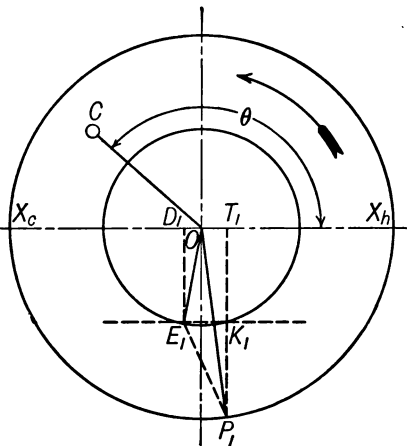

FIG. 98.

end, while the riding valve is displaced a distance OT in the same direction. The riding valve is therefore displaced toward the crank end more than the main valve by an amount DT , that is, its displacement *relative to the main valve* is DT .

Now draw a line MN through E parallel to X_cX_h . Then EK is equal to DT and therefore is equal to the displacement of the riding valve relative to the main valve.

In Fig. 98 the same mechanism is shown with the crank turned through the angle θ from the head-end dead point. The main valve is now displaced a distance OD_1 toward the crank end and the riding valve a distance OT_1 toward the head end; the riding valve is therefore displaced toward the *head end relative to the main valve* an amount D_1T_1 ,

equal to E_1K_1 . From these two figures it will appear that the motion of the riding valve *relative to the main valve* is the same as if the main valve did not move and the riding valve were driven by an eccentric whose eccentricity is EP and whose angle with the crank is NEP . This

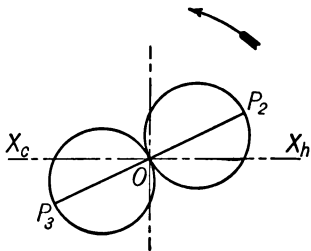

FIG. 99.

being the case it is possible to represent the relative motion by a valve circle whose diameter is EP and whose angle with the line of centers is equal to NEP . This is shown in Fig. 99 where angle X_cOP_2 is equal to angle NEP , Fig. 97, and $OP_2 = OP_3 = EP$. In order to distinguish these circles from those which would be used to represent the absolute displacements of the main valve and riding valve we will call these

circles which represent the relative displacements the *relative displacement circles*. Fig. 100 contains all three sets of valve circles. It will be noticed that the diameter of the relative displacement circle (OP_2) is one side of a parallelogram EOP_2P of which the other side is the diam-

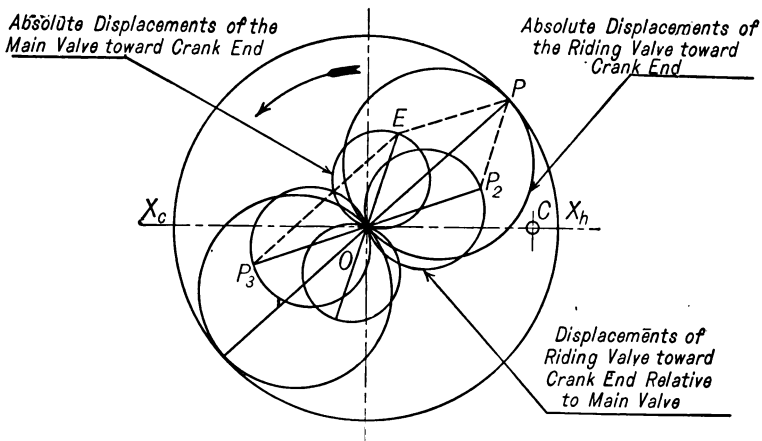

FIG. 100.

eter of the main valve circle and the diagonal is the diameter of the circle which shows absolute displacements of the riding valve. Also the diameter OP_3 is one side of a parallelogram OP_3EP . The use of one or the other of these parallelograms is often convenient in constructing the circle.

65. Two General Classes of Riding Cut-off Valves. Riding cut-off valves may be divided into two general classes:

1. Constant clearance valves.
2. Variable clearance valves, commonly called Meyer valves.

66. Constant Clearance Valves. The most common form of riding cut-off valve is that shown in Fig. 93, where the clearances, having been determined in the process of designing and setting, remain unchanged. The action of this valve has already been described. The governor controlling it may be of any one of the types discussed in Chapter V. The position of the pivot point of the eccentric is of importance in the case of the double valve as well as of the single valve, although the importance may not be so great, and a type of governor which would give very unsatisfactory steam distribution with a single valve may be designed to give good results with a double valve. We will consider two positions of the pivot point in order to study more in detail the operation of the valve and the method of applying the Zeuner's diagram to its design. These positions are: First, the one which gives constant *absolute* travel to the riding valve; second, the one which gives constant travel of the riding valve *relative to the main valve*.

67. Constant Absolute Travel Riding Valve. Fig. 101 shows a shaft governor used to drive a riding cut-off valve. The eccentric is supported on the shaft and turns relative to the axis of the shaft when the governor weights *W* move out as the result of increasing speed of rotation. In other words, the pivot point for this eccentric is at the axis of the shaft so that the governor merely changes the angle which the eccentric makes with the crank. The absolute travel of the riding valve is, therefore, constant and, as will appear when we study the Zeuner's diagram, the relative travel varies.

Let us assume that we have sufficient data to determine the valve circles for the main valve and locate the crank positions for the events of the stroke controlled by the main valve. Also, assume that for the riding valve we know the absolute travel, the clearances and the travel relative to the main valve. We wish to find the position of the riding valve eccentric relative to the main eccentric and the crank angle at which the riding valve gives cut-off. Then, assuming that the absolute travel remains constant, find through what angle the riding valve eccentric must be moved relative to the main eccentric to give cut-off at a crank angle of 90° and find the relative travel for that setting. We will work for the head end only.

In Fig. 102 OE is the main valve circle. The main valve events for the head end are lettered in the usual way. To get the position of the relative displacement circles construct the parallelogram OV_2EP_1 with

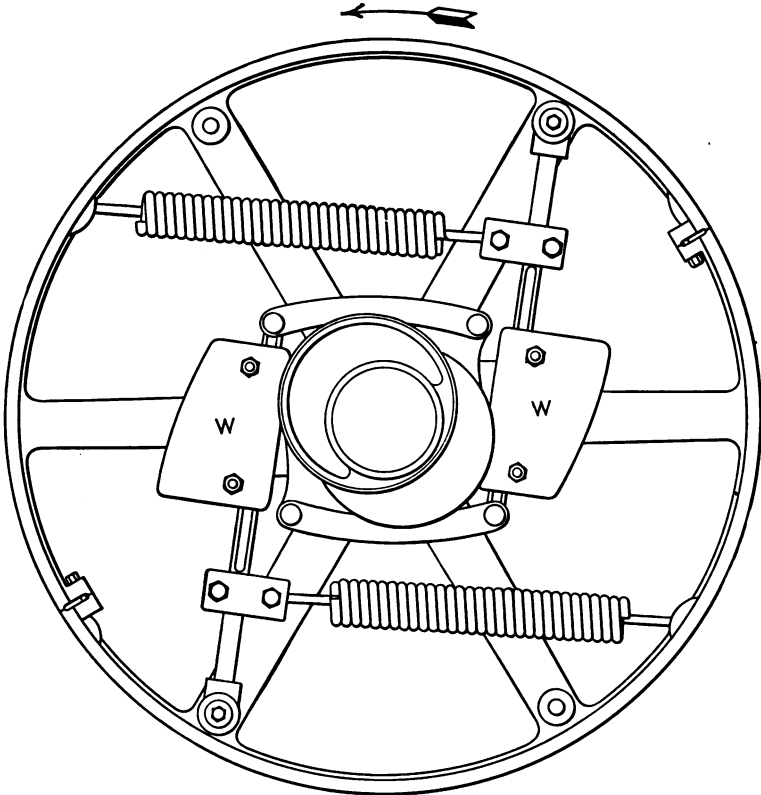

FIG. 101.

OE as a diagonal and the sides EP_1 and OP_1 equal respectively to one half the relative travel and one half the absolute travel of the riding valve. On OV_2 thus found draw the relative displacement circle. Produce OV_2 making $OV_1 = OV_2$ and OV_1 will be the diameter of the other relative displacement circle. The angle EOP_1 is then the angle between the two eccentrics. About O draw a circle with radius equal to the head-end clearance of the riding valve. This intersects the relative displacement circle OV_2 at F . Then OC_{h1} drawn through F will be the crank position for head-end cut-off by the riding valve because when the crank is in that position the riding valve is displaced toward the head end

relative to the main valve an amount equal to the head-end clearance and is moving toward the head end of the main valve. To solve the second part of the problem draw the crank position OC_{h2} for the changed

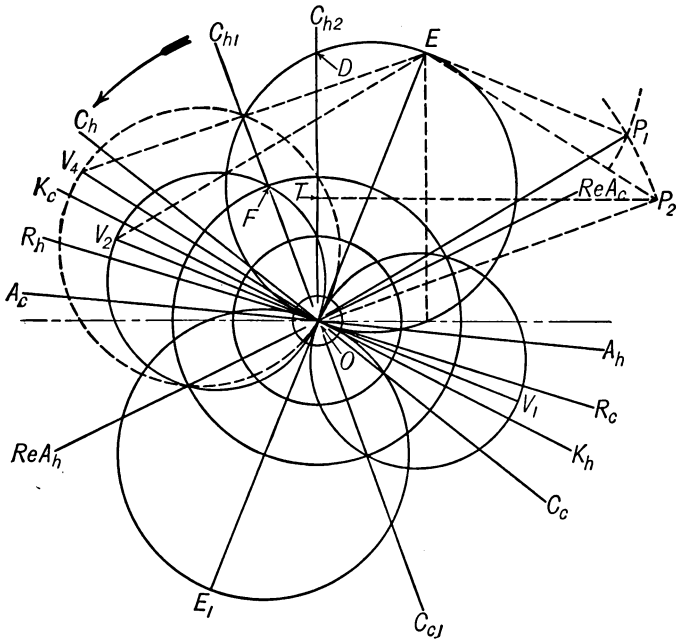

FIG. 102.

cut-off. When the crank is at OC_{h2} the main valve is displaced a distance OD toward the crank end and if the cut-off by the riding valve is to occur at that time the actual displacement of the riding valve must be OD minus the head-end clearance. Therefore measure in DT equal to the clearance, and OT will be the absolute displacement of the riding valve. Now find the diameter OP_2 of a circle which shall pass through O and T and which shall be equal to OP_1 (since the absolute travel is unchanged). Then P_1OP_2 is the angle through which the eccentric must be moved relative to the rest of the mechanism to shorten cut-off by the riding valve from OC_{h1} to OC_{h2} . By constructing a parallelogram with OE as the diagonal and OP_2 as a side we get OV_4 as the diameter of one of the relative displacement circles. Therefore OV_4 is one half the relative travel of the riding valve for this setting.

Another example of the same type of valve and governor is shown in Fig. 103. Here it is assumed that the main valve data is at hand,

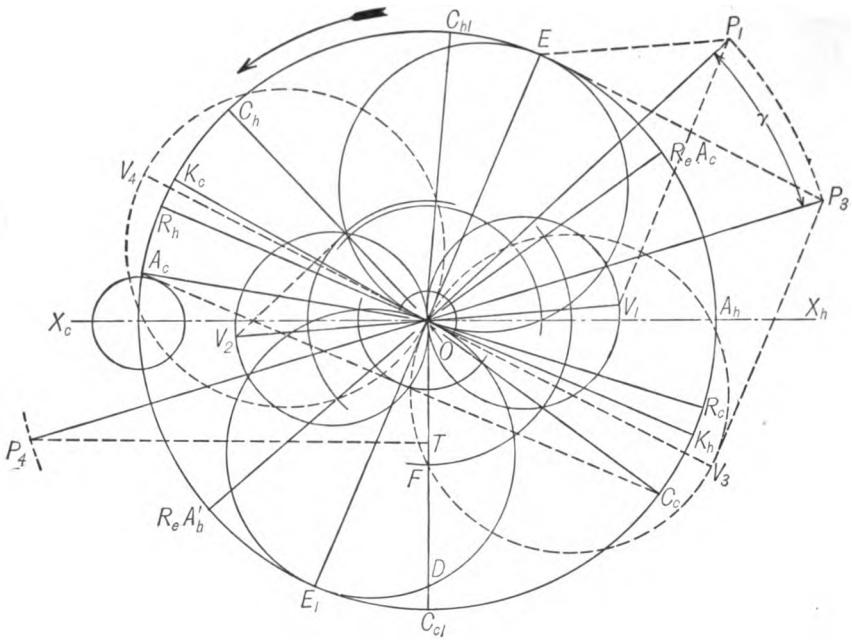

FIG. 103.

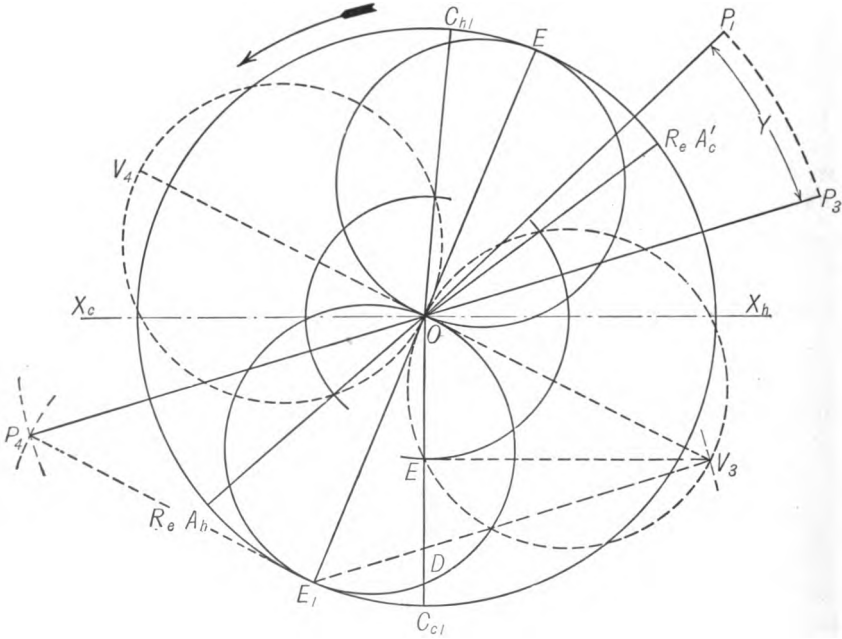

FIG. 104.

also the relative travel of riding valve when the eccentric is set for the riding valve to cut-off on both ends at the same time as the main valve cut-offs. The head-end clearance of the riding valve is also known. To find the absolute travel of the riding valve, the crank-end clearance, the position of the riding valve eccentric relative to the main eccentric when set for cut-off as above stated; then, assuming that the governor is to shift the eccentric so that crank-end cut-off by the riding valve occurs at a known crank angle earlier in the stroke, to find the angle through which the eccentric must be shifted, the relative travel for this grade, and the position of head-end cut-off corresponding to the shortened crank-end cut-off. The stroke line is omitted from the figure although it was used in getting the various crank positions.

The main valve circles are first drawn and the crank positions for main valve events located from the data. Since the relative travel of the plate on the valve is known for longest cut-off the diameter of the relative displacement circle for this setting must be one half this relative travel. If the riding valve is to give head-end cut-off at the crank position OC_h (the same as main valve head-end cut-off) it must be displaced toward the head end relative to main valve, at that time, an amount equal to head-end clearance. Therefore, the relative displacement circle OV_2 must be drawn in such a position that its intercept on OC_h will be equal to the head-end clearance. This can be done by drawing about O an arc with radius equal to the clearance and finding the center of a circle of the required diameter which will pass through O and the point where the clearance arc cuts OC_h . In this way the diameter OV_2 is found and from that OV_1 . Then by constructing the parallelogram EOV_1P_1 and drawing its diagonal OP_1 we find the eccentricity of the plate eccentric and its setting for latest cut-off. The arc drawn about O passing through the intersection of the circle OV_1 with line OC_c will have a radius equal to the crank-end clearance. To get the setting of the eccentric for the shortened crank-end cut-off and to find the relative travel for that setting, consideration had better be given to the actual position of the valves rather than to a purely geometric construction. OC_d is the crank position for this shorter crank-end cut-off. At that time the main valve is displaced a distance OD toward the head end and if cut-off by the plate is to occur then it must be displaced an actual amount equal to OD minus the clearance. Therefore measure in from D the clearance, getting OT as the absolute displacement of the plate. Now, since the eccentricity of the plate eccentric is constant

it is only necessary to find the line OP_4 , which is the diameter of a circle equal to OP_1 and passing through O and T . The diameter of the other circle is, of course, found by producing P_4O to P_3 and the relative displacement circles are then found for this grade by constructing the parallelogram OEP_3V_3 with OP_3 as a diagonal and OE_1 as one side. The crank position for head-end cut-off for this setting of the eccentric is found by drawing OC_{41} through the intersection of the head-end clearance arc with the relative displacement circle OV_4 .

Fig. 104 is another solution of the same problem in which the position of the point P_4 is formed directly by constructing the parallelogram $OV_3E_1P_4$ instead of getting P_4 by reference to the actual valve displacements. This construction is a little shorter than that used in Fig. 103, but should not be employed unless the one using it knows what he is doing.

68. Constant Relative Travel Riding Valve. If the shifting eccentric, instead of being swung about the center of the shaft, as was the case in Figs. 101 to 104, is supported at a point coincident with the center of the main eccentric, the relative travel will be constant. A diagram for such a case is shown in Fig. 105. Fig. 106 is a sketch of the main eccentric and of the pin P on the governor arm to which the eccentric rod for the riding valve is attached and which, therefore, takes the place of an eccentric. This arm is pivoted at a point on the flywheel which coincides in projection with the center E of the main eccentric. Consequently as the governor weights swing out the relative eccentricity does not change.

69. Double Piston Valve. Fig. 107 is an example of the riding cut-off valve principle applied to a piston valve as used on the Buckeye engine.

70. Layout of Double Valve. In Fig. 108 is shown the layout in longitudinal section of the valve for which Fig. 103 is the diagram.

The main valve seat and the middle part of the main valve are laid out as already discussed in Chapter IV for any plain slide valve. The width of the opening Lb is made sufficient so that when the valve is displaced its greatest amount toward the head end, as indicated by the line at b_2 , the opening b_2k will be enough to admit the steam properly. That is, b_2k should not be less than am . The distance bc is enough to prevent leakage past c into the port when the valve is in extreme position. The same statements apply to passage L_1b_1 and the wall b_1c_1 .

The position of the upper ends of the valve passages is more or less

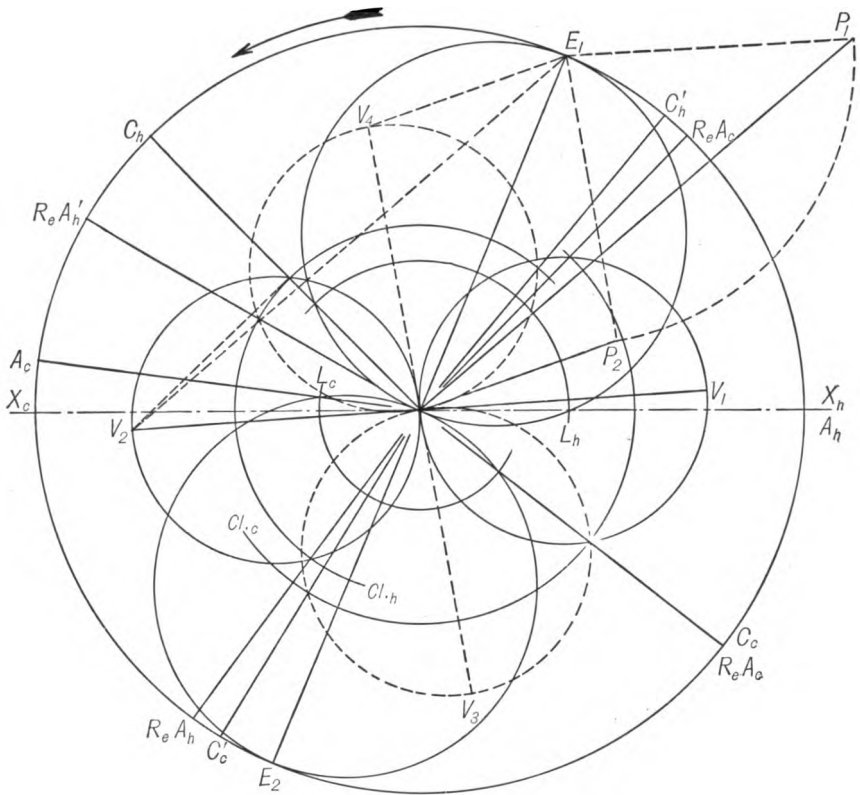

FIG. 105.

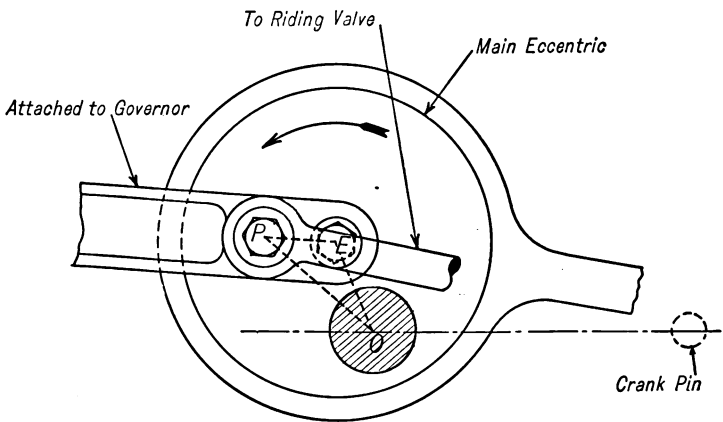

FIG. 106.

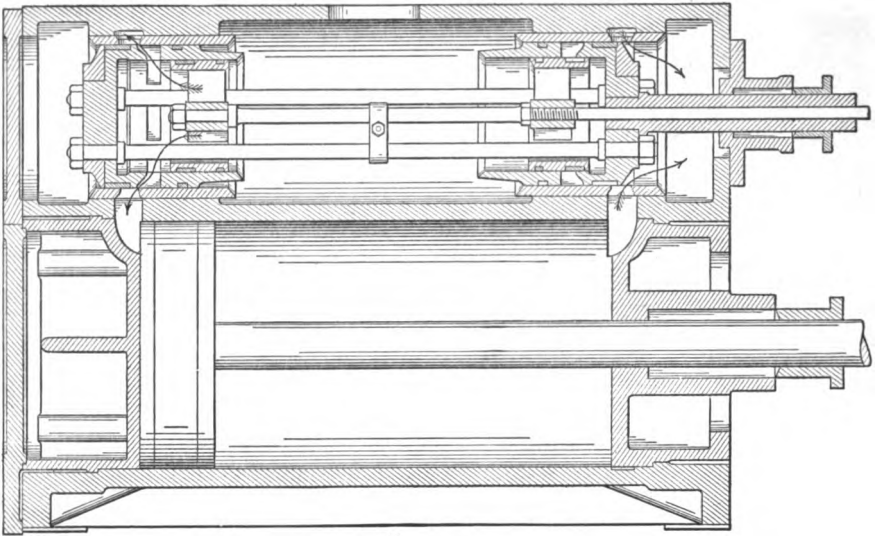

FIG. 107.

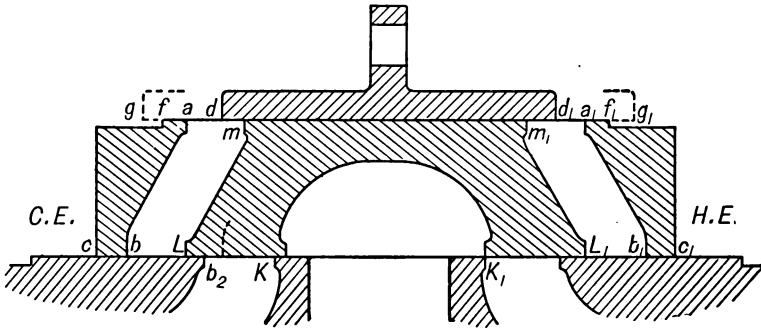

FIG. 108.

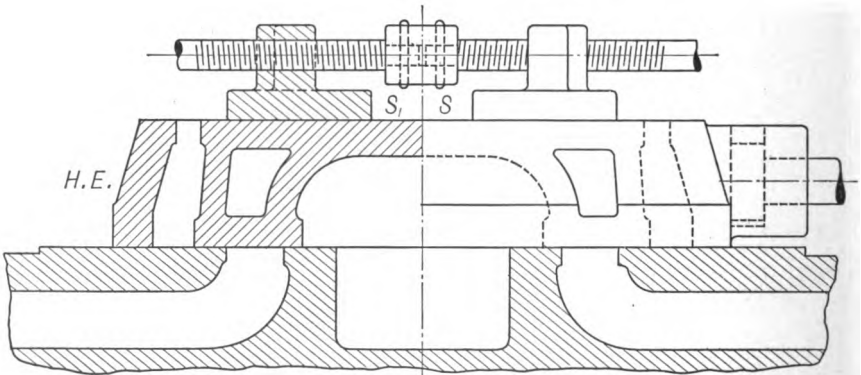

FIG. 109.

arbitrary. It is desirable to keep the valve as short as convenient; on the other hand, the valve passages should not slant enough to prevent free flow of the steam into the cylinder ports. Other proportions of the valve are determined by practical considerations of strength and convenience in construction. In the figure both valves are drawn in actual

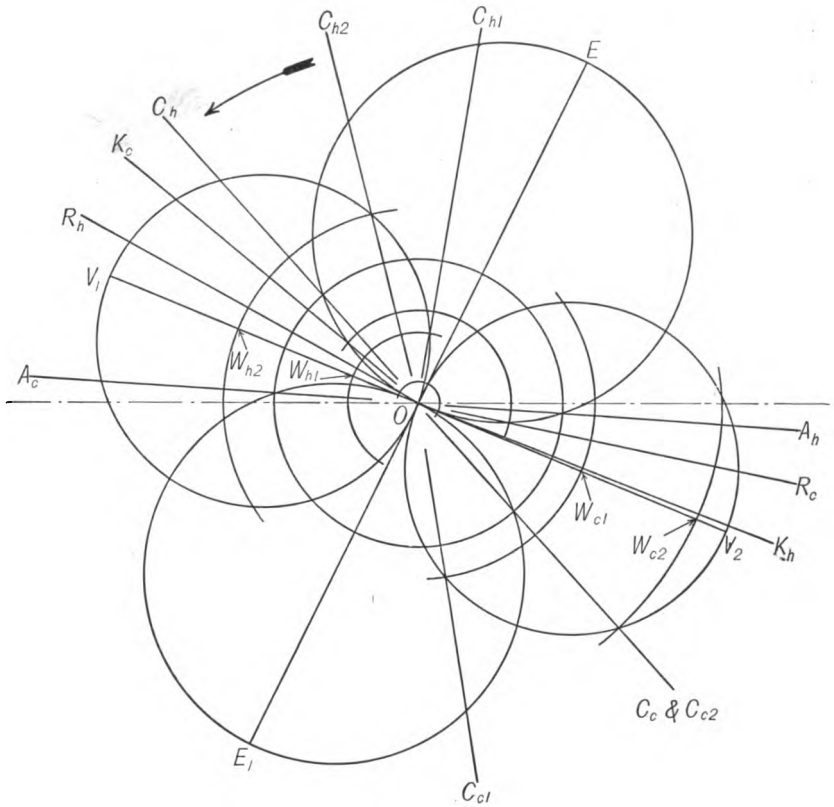

FIG. 110.

mid-position, which condition, of course, never exists when connected up to run.

71. Meyer Valve. A Meyer valve is shown in Fig. 109. The riding valve consists of two plates connected by a right and left screw and is driven by a fixed eccentric. The screw comes out through the head end of the valve chest and is provided with a hand wheel so that by turning the screw the plates may be set nearer together or separated, thus changing the clearances.

Fig. 110 is a Zeuner's diagram for a Meyer valve where the eccentric is set so that the line V_1OV_2 , which forms the diameters of the relative displacement circles, falls behind the main valve cut-off lines OC_c and OC_h . In this particular diagram the clearances are chosen to equalize cut-off at $\frac{1}{2}$ stroke. The maximum clearance on the crank end is OW_{c2} and on the head end is OW_{h2} .

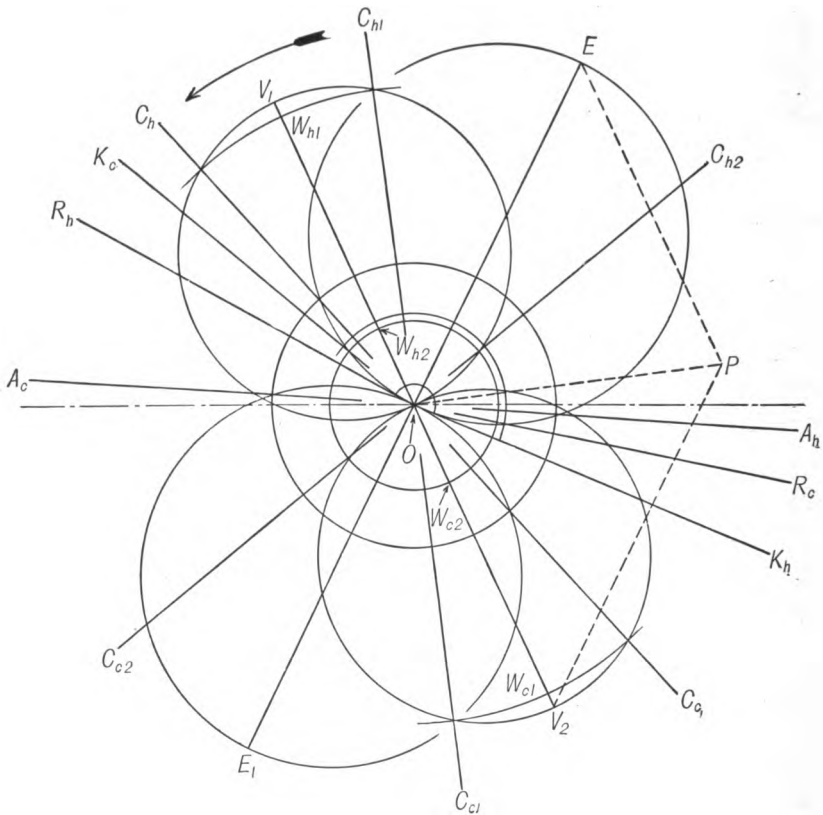

FIG. III.

Fig. III is a similar diagram where the diameters of the relative displacement circles V_1OV_2 fall ahead of main valve cut-off lines.

72. Layout of Meyer Valve. The layout of the bottom part of the Meyer valve is the same as for a constant clearance valve. The plates at the top must be long enough to seal at the edges S and S_1 , Fig. 109, when set with least clearance and when displaced the maximum amount relative to main valve.

CHAPTER VII

MULTIPLE-VALVE ENGINES

73. The majority of large stationary engines are multiple-valve engines, the most common practise being to use four valves, one at each end of the cylinder for admission and cut-off, and one at each end for release and compression.

The multiple valve engines discussed in the present chapter are only a few of the many kinds in use, but will serve to illustrate the principle of the valve mechanism of such engines.

74. **Corliss Valve Mechanism.** One of the first multiple valve engines was that invented by George H. Corliss. The principle of the Corliss valve gear has been, and still is, widely used on large engines of moderate speed. The details of the gear as applied by the various builders

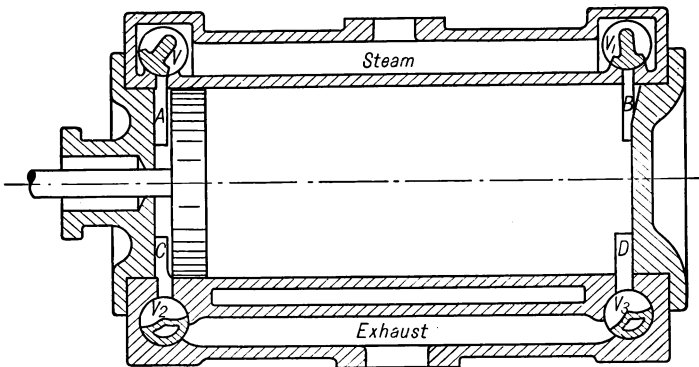

FIG. 112.

differ to a considerable extent, and many of the modifications have the names of the designers or builders prefixed to the word Corliss.

(Fig. 112 is a longitudinal section of the cylinder of an engine having a Corliss valve gear. There are four valve chests extending crosswise of the cylinder, one at each corner. Each valve seat is an arc of a cylindrical surface, and each valve is a portion of a cylinder resting on this

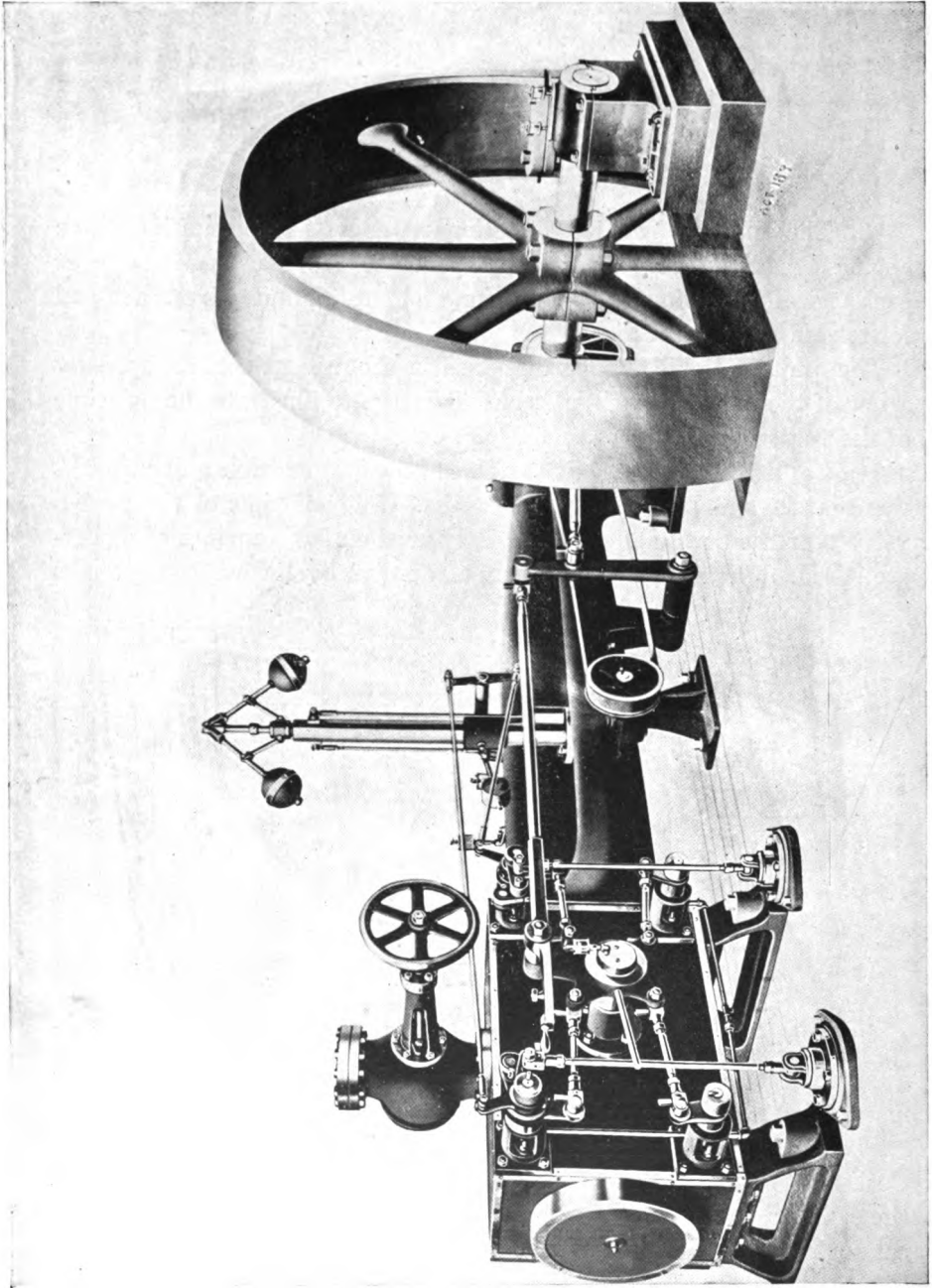

FIG. 113. Corliss Engine. Hooven, Owens, Rentschler Co.

surface. These cylindrical valves oscillate about their respective axes to open and close the ports. The valve V controls admission and cut-off for the crank end, V_1 admission and cut-off for the head end, V_2 release and compression for the crank end, and V_3 release and compression for the head end. A and B are the steam ports and C and D the exhaust ports. The engine is shown exhausting at the head end, and approaching admission at the crank end, although no attempt was made in the drawing to place the valves exactly in their proper relative positions.

Fig. 113 is a general view of a Corliss engine built by the Hooven, Owens, Rentschler Company, Hamilton, Ohio. The main working parts of the valve mechanism can be seen from this figure, and from

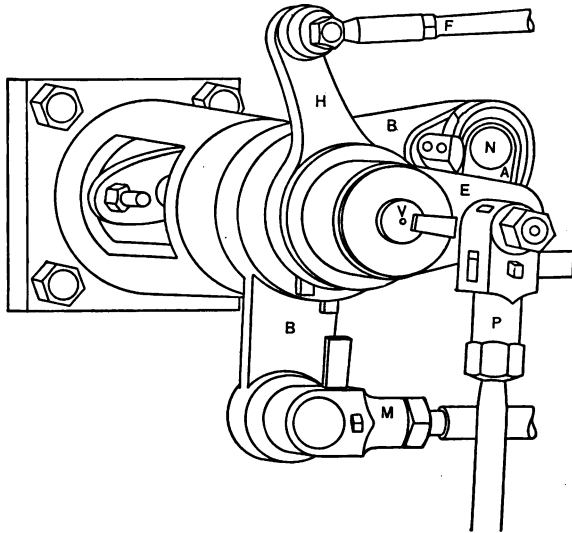

FIG. 114.

Fig. 114 which is an enlarged view of the "releasing gear" operating the steam valves.

A casting, called the wrist plate, oscillates on an axis bolted to the center of the cylinder casting. Motion is given to the wrist plate by an eccentric on the main shaft through an eccentric rod, rocker or "carrier," and reach rod. Short cranks or "exhaust arms" are keyed to the stems of the exhaust valves and are connected to the wrist plate by the "exhaust links." The exhaust valves are, therefore, in motion all the time. The proportions of the linkage are such, however, that the motion of the valves is as slow as possible when they are open and

closed, while at the time they are opening and closing the motion is rapid. Motion is imparted to the steam valves from the wrist plate through the steam links. The steam links are not attached directly to the steam valves as was the case with the exhaust links, but move the valves through a releasing device shown in Fig. 114. This releasing mechanism is so constructed that the steam link pulls the valve open quickly at the proper time, and by releasing its hold on the valve stem allows the valve to close suddenly under the action of external forces when cut-off position is reached. The time at which the gear allows the valve to close is controlled by the governor. This is seen at the middle of the engine, and consists of two heavy balls supported on arms hinged at the top of a vertical shaft. The shaft is rotated through bevel gears by the shaft carrying the small pulley which shows directly below. The pulley is driven by a belt from the engine shaft. The arms carrying the governor balls are connected by short links to a collar on the vertical shaft, and as the speed of rotation causes the balls to swing out this collar is drawn upward. The position of the collar determines the position of a stop which causes the releasing gear to let go its hold on the valve.

75. Allis Releasing Gear. Fig. 115 is a perspective drawing and Fig. 116 an orthographic projection of the head-end steam valve mechanism on an Allis engine built a number of years ago, but shown here because it differs only in minor details from similar gears made today, and lends itself well to an explanation of the detail of action of Corliss gears in general. The parts in Fig. 115 are lettered the same as the corresponding parts in Fig. 114, so that if Fig. 115 is understood it will be easy to follow the action of the gear which is shown in Fig. 114.

Referring to Figs. 115 and 116, the rod *M* is the steam link connecting the end of the steam bell crank *B* to the wrist plate. The wrist plate oscillates continuously through an angle of about 55° , driven by an eccentric as explained for the engine shown in Fig. 113. The mechanism is in extreme position in Figs. 115 and 116, with the wrist plate about to reverse its motion. The valve is closed. As the top of the wrist plate moves toward the left the right arm of the steam bell crank *B* rises, and the left arm swings down. Pivoted on the pin *N*, on the left arm of *B*, is the claw *A* having near its end a hardened steel block *T*. The steam arm *E* is keyed to the shaft *V* which is really the stem of the valve and which, when turned, causes the valve to turn. On the back side of *E* is another hardened steel block *C*. A spring *Y* is attached to *B*, and

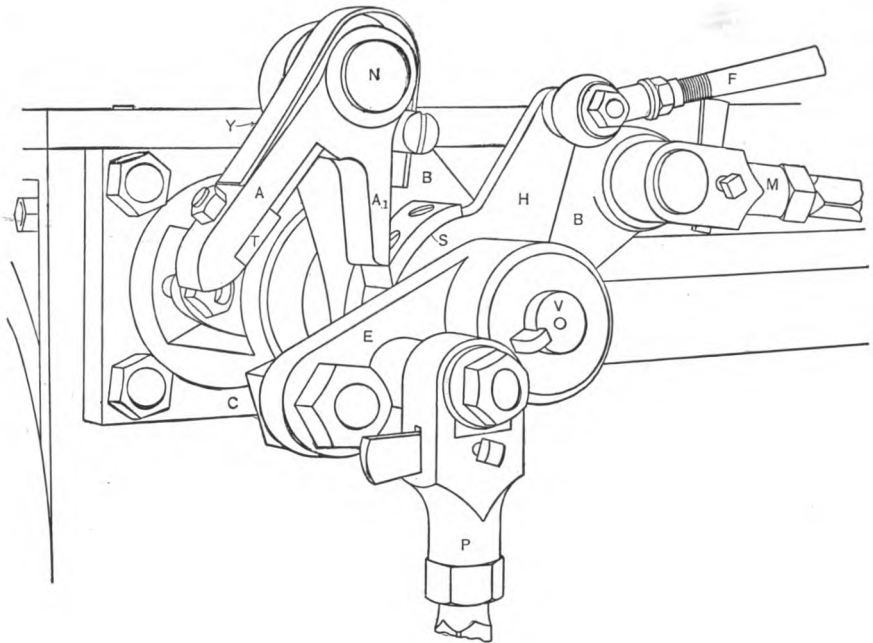

FIG. 115.

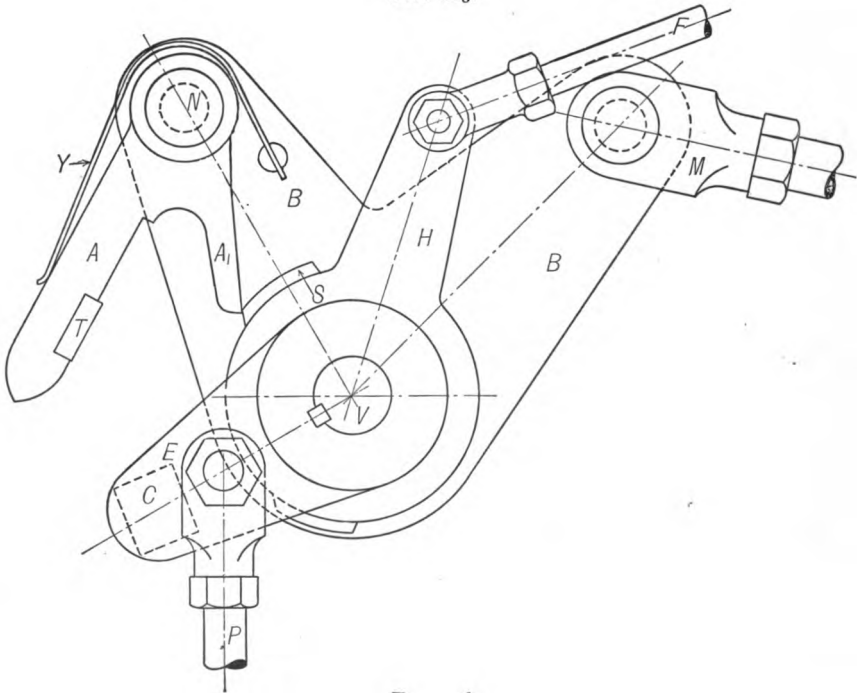

FIG. 116.

rests against the outer arm of *A* urging it inward. The steam bell crank *B* swings just far enough to allow the block *T* to go a little way past block *C*. Then as *B* reverses its motion and begins to move upward, the arm *A*, urged inward by the spring, causes the block *T* to hook under *C*, and, therefore, pulls *C* and *E* upward, opening the valve. Loose around the hub of *B* is a ring having an arm *H* connected by the rod *F* to the levers operated by the governor collar. As the pin *N* rises, the toe *A*₁, which is a part of claw *A*, strikes the stop *S*. This causes the claw to swing about pin *N* with the result that the block *T* is unlatched from *C*. Attached to *E* is the rod *P* running down to a "dash-pot." When the claw unhooks from *C*, the suction of the dash-pot combined with the weight of the parts causes *E* to drop suddenly and close the valve producing cut-off for that end of the cylinder. If the arm *H* is moved a little to the left (which occurs when the governor balls move out) the stop *S* is moved down a corresponding amount. Then *A*₁ strikes it sooner, as *B* swings up, thus giving an earlier cut-off.

76. Double-ported Corliss Valve. Corliss valves may be made double ported. Fig. 117 shows a section of the head end of the cylinder of a Hamilton engine. Steam enters past the right-hand edge of the steam valve, and also by the passage *P* through the valve. The exhaust goes out past the right edge of the exhaust valve and through the passage *R*. It will be noticed on each of these valves that the bridge between the two ports furnishes a support for the valve throughout its entire length at all times, thus obviating any tendency to spring.

77. Dash-Pot. Since reference has been made to a dash-pot in connection with the Corliss releasing gears it may be well to notice here the construction of one form of dash-pot. Fig. 118 is a section through a dash-pot sometimes used on the Hamilton engine. *P*₁ is a piston having a large diameter at the upper part and a smaller diameter below. The pin *R* furnishes the connection between the piston and the connecting link *P*, Fig. 114. When the piston is drawn up a partial vacuum is formed under the piston, tending, of course, to draw the piston down as soon as the upward force is removed by the action of the releasing gear. A cushion of air under the upper part of the piston prevents shock when the piston drops suddenly. This air escapes through a small opening, but escapes so slowly that it is compressed and in that way cushions the piston.

78. Limitation of Cut-off with Single Wrist Plate. If a Corliss engine has but one eccentric, and one wrist plate to drive both steam and ex-

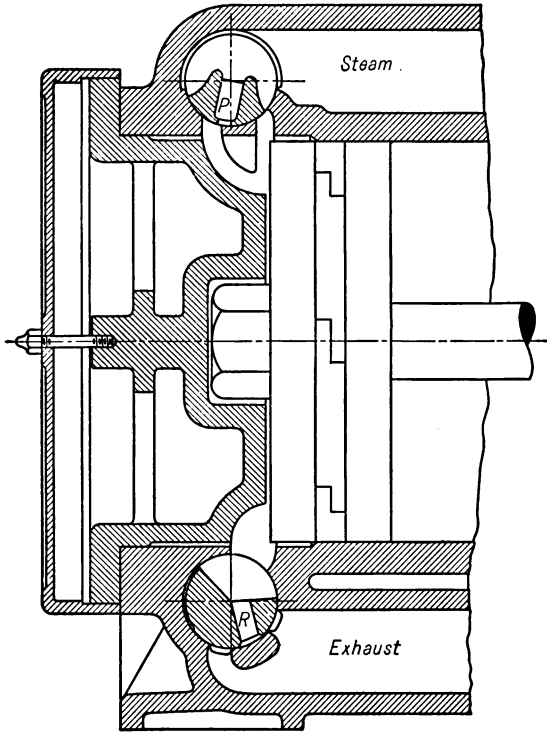

FIG. 117.

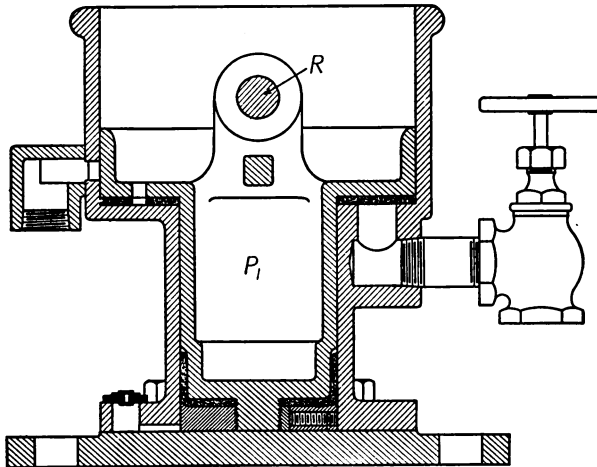

FIG. 118.

haust valves, the eccentric would ordinarily have to be set 90° or more ahead of the crank in order to give a favorable action of the exhaust valves. This necessity imposes a limitation on the time of cut-off by the releasing mechanism. This may be seen from the diagram of such a gear in Fig. 119. X is the center of the eccentric, and is now on the center line of the engine. The entire linkage is, therefore, in its extreme position, and a further motion of the eccentric will cause the steam bell crank B to swing toward the left. If the finger A_1 has not come in contact with the governor stop S by the time the linkage reaches the position

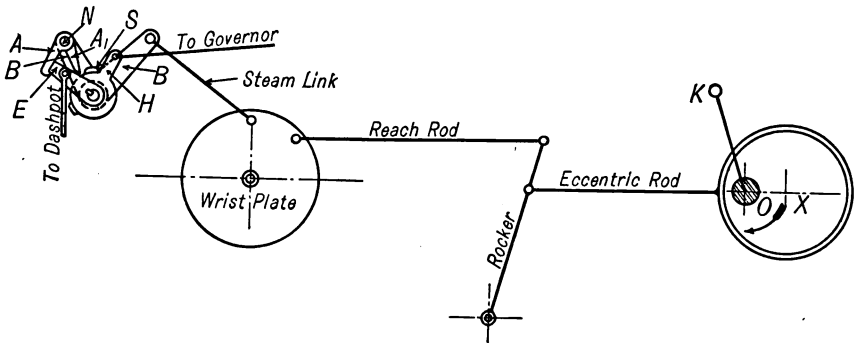

FIG. 119.

shown, it will not strike S at all, and the releasing mechanism will not operate at all. As B swings back it will gradually lower the steam arm E , and close the valve near the end of the stroke. This will, of course, give cut-off, but the cut-off will not be under control of the governor. In other words, the "drop" cut-off must occur by the time the center of the eccentric is on the engine center line. If the angle between the crank and eccentric needs to be XOK in order to give proper exhaust action, then the position OK is the latest crank position at which cut-off can be obtained and still be kept under control of the governor. This difficulty is often overcome by using two wrist plates, one for the steam valves and the other for the exhaust valves. Each wrist plate is driven by its own eccentric. The steam eccentric may then be set wherever desired without interfering with the exhaust.

79. Rice & Sargent Valve Gear. Figs. 120 to 123 show the steam and exhaust gears of the Rice & Sargent engines built by the Providence Engineering Works. These are Corliss engines in which no wrist plates are used. The drawings and the greater part of the following description are taken directly from the makers' catalogue.

The valves, Fig. 120, are of the multiported Corliss type. On small and medium-sized cylinders double-ported valves are used, both for steam and exhaust, and on the largest sizes triple-ported valves are used, insuring ample port opening with slight valve movement. The inlet valve gear is shown in Figs. 121 and 122. Fig. 121 shows the crank-end steam gear in its extreme opening position. The latch *A* on the valve stem lever *B* is engaged with the toe *C* on the rocker *D*. The pin *E* connects through the intermediate rockers and rods with the steam eccentric on the engine shaft, and the pin *F* connects to a similar gear at the head end of the cylinder. As the rocker *D* moves to the right, the toe *C* engages the latch *A*, moving the inlet valve to open it, and

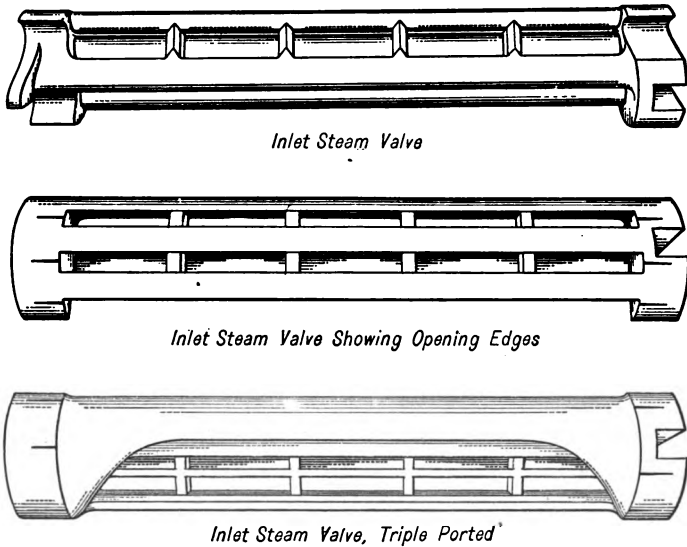

FIG. 120.

raising the dash-pot plunger which is connected to the pin *P*. Cut-off is accomplished by the toe *C* turning downward on its pivot spindle *H* to release the latch *A*. The spindle *H* has a cam lever *I* rigidly attached in the rear, which in turn is carried between two hardened steel rolls, *J, J*. These rolls turn on pins in the cut-off lever *K*, which latter is a part of the collar, turning freely on the valve stem journal. The arm *L* above, forming part of the same casting as the cut-off lever *K*, is connected to the governor by the rod *M*. This rod is held firmly by the governor, and does not move unless there is a change in speed of the engine. The rod *N* connects to the valve gear at the head end

of the cylinder. The latch *A* is released at some point in the opening movement of the rocker *D* toward the right. This is accomplished when the rise *O* of the cam lever passes between the cam rolls *J, J*. It is obvious that the length of the cut-off depends upon the position of the cut-off lever *K*, as controlled by the governor. The further to the left the lever *K*, the earlier the cut-off.

Fig. 122 shows the rocker *D* at the extreme right of its motion. Release has taken place, and the valve is about to be closed by the pull of

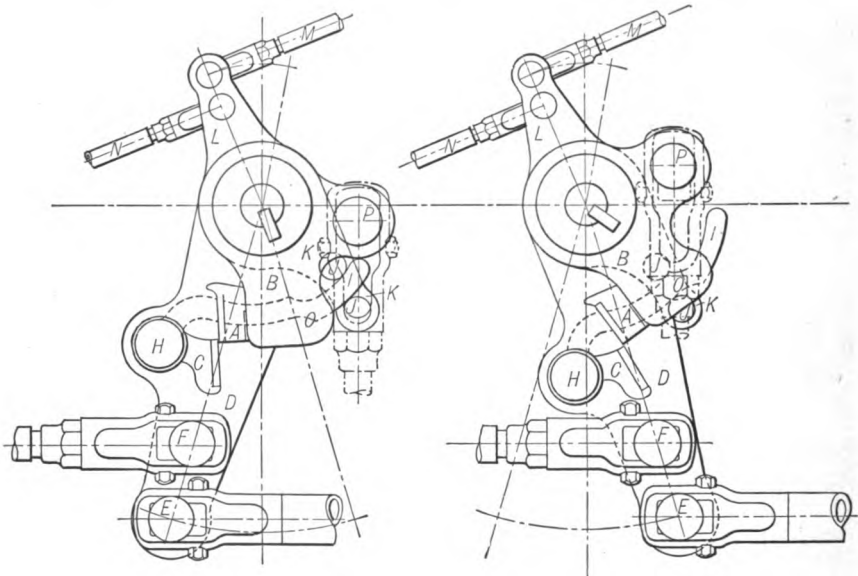

FIG. 121.

FIG. 122.

the dash-pot. The valve closes promptly, and the lever *B* turns to the position shown in Fig. 121. The cut-off lever *K* is here shown in the position giving nearly the latest cut-off which is about three-quarter stroke of the piston. On the return movement of the rocker *D* the cam rolls *J, J* raise the cam lever *I* and the toe *C* to the engaging position. At the latter part of the movement of the rocker *D* to the left, as the toe *C* passes under the latch *A*, the latter is raised by the toe sufficiently to clear the same, and the latch then drops by gravity in front of the toe to the engaging position.

The exhaust valve gear is shown by Fig. 123. The link is interposed between the valve rod bell crank and the exhaust lever to allow the valve to pause at the time the pressure upon it is heaviest, thus

minimizing the friction loss and giving rapid motion at the time of opening and closing the ports. Separate eccentrics are used for operating the steam and exhaust valves, permitting a long range of cut-off and satisfactory adjustment of release and compression.

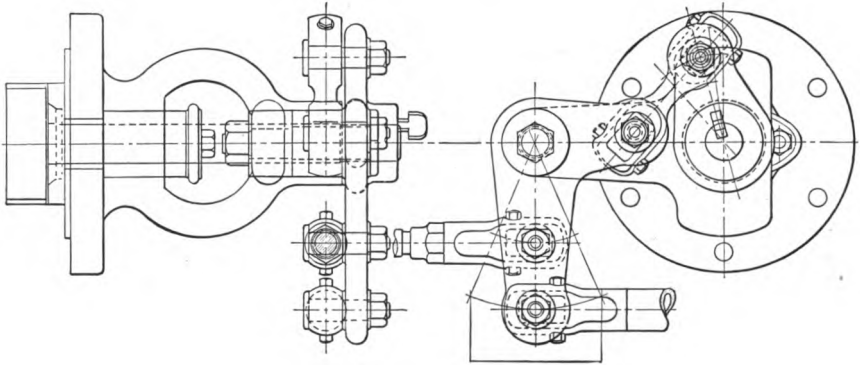

FIG. 123.

It is claimed that this gear can be used with satisfactory results on an engine running as high as two hundred or more revolutions per minute.

80. Fitchburg Four-valve Engine. Fig. 124 shows the head-end steam and exhaust valves and the valve gear for the Fitchburg engine.

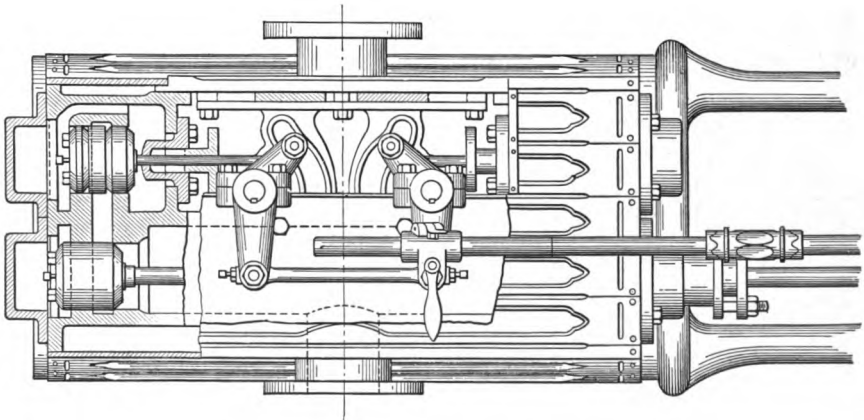

FIG. 124. Valve Mechanism of the Fitchburg Engine.

The stems of the steam valves are attached to sliders having cam grooves. Each slider is moved by a rocker which swings about a fixed axis. The lower ends of these rockers are attached to each other through a link,

and to an eccentric on the engine shaft by rods and carriers. The upper ends of the rockers carry rolls fitting into the grooves of their respective cams. The larger part of each cam groove is nearly concentric

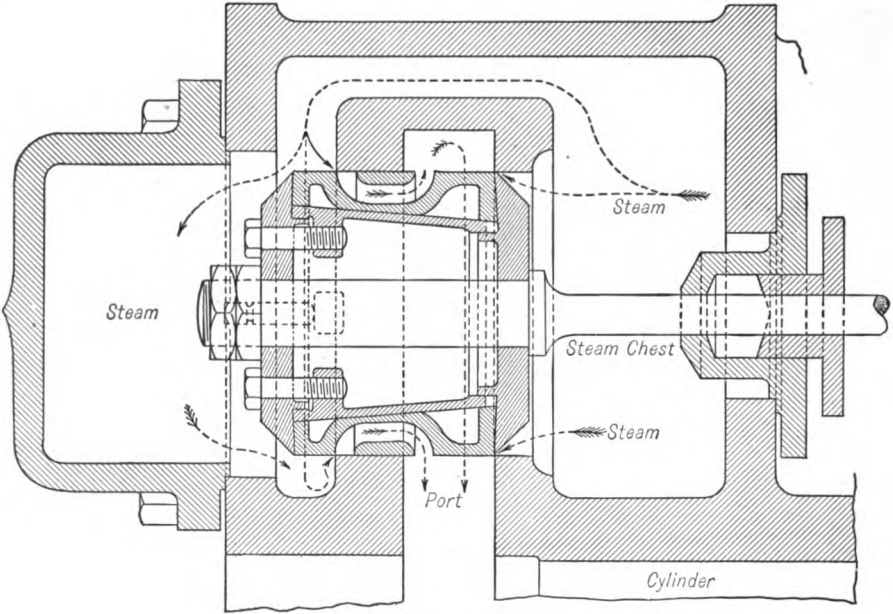

FIG. 125.

with the axis of the rocker which drives it, the groove being just enough off to cause the driving pin and roll to start the cam at the beginning of its movement so that when the roll reaches the reverse curve, which begins the quick travel of the valve, the latter is already in motion in the direction of its travel.

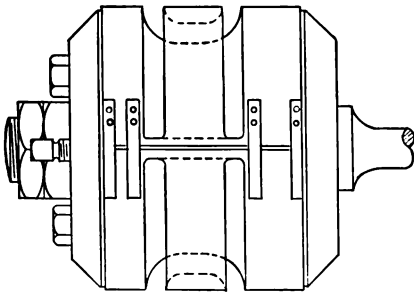

FIG. 126.

Fig. 125 is a section through the head end valve and valve chest, and Fig. 126 an outside view of the valve. Steam is at both ends of the valve, and the area exposed to pressure is less at one end of the valve

than at the other by the area of the valve stem. This small unbalanced pressure is just enough to keep the cam against its driving roll. It will also close the valve instantly in case the valve rod or eccentric rod or the driving latch should break or be detached by accident.

These valves furnish a good example of double-ported piston valves.

The governor for this engine is shown in Fig. 127. This is the governor referred to in § 57, in which the eccentric is moved straight across the shaft as the weights swing out, keeping the lead constant, although the mechanism is sometimes so arranged that the movement of the

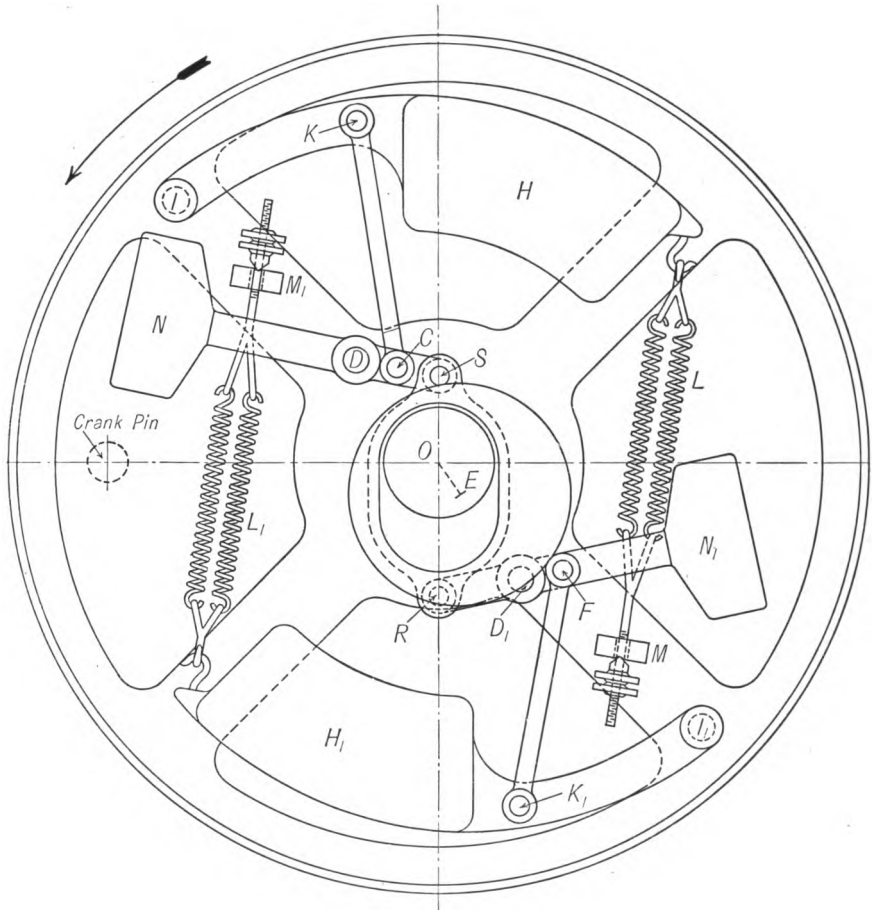

FIG. 127. Governor of the Fitchburg Engine.

center of the eccentric is in a straight line, relative to the center line of the crank, but not at an angle of 90° . This is done to give a decreasing lead as the cut-off shortens.

The center of the eccentric is at *E*, and it is slotted so that it does not touch the shaft. At the two points, *D* and *D₁*, are pins by means of

which the two weighted levers N and N_1 are pivoted to the flywheel. These levers take hold of the eccentric at the pins S and R . (The lugs to which these pins are fastened are a part of the eccentric casting.) The four-bar linkage $DSRD_1$ is, therefore, practically a Watt straight-line motion. The result of swinging the levers about D and D_1 is to move the center of the eccentric in nearly a straight line relative to the center line of the crank. The weights H and H_1 are pivoted to the wheel at I and I_1 , and are connected to the levers DS and D_1R by the links KC and K_1F . The springs L and L_1 are attached at one end M and M_1 to the wheel, and at the other end to the weights H and H_1 , thus serving to hold the weights in toward the center and tend to keep the eccentric set for latest cut-off. As the speed of the wheel increases the weights H and H_1 swing out, turning the levers DS and D_1R about the pins D and D_1 so as to carry the eccentric center E nearer the center line of the crank.

The weights N and N_1 merely act as counterweights.

81. McIntosh & Seymour Gridiron Valves. Fig. 128 shows at the left a transverse section of the cylinder of a McIntosh & Seymour engine,

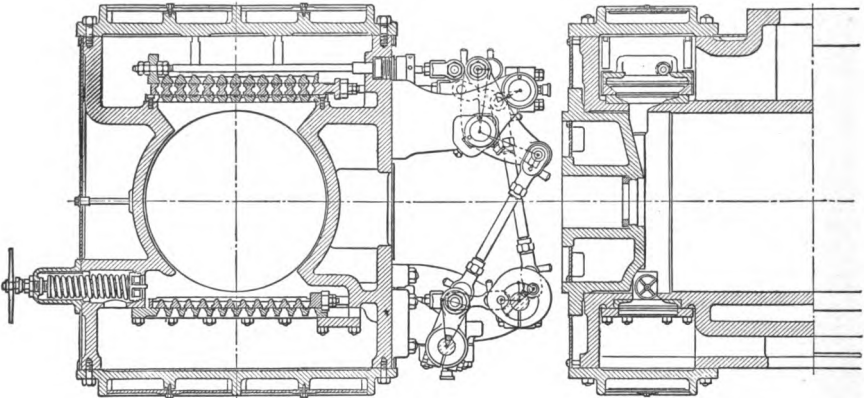

FIG. 128. Valve Mechanism of the McIntosh & Seymour Engine.

the section passing through the valves. At the right is a longitudinal section through the crank end of the cylinder. The valves illustrate the form of valve known as *gridiron*. Each exhaust valve is a series of little plates cast together. The valve seat contains a port for each section of the valve. The principle here is evidently the same as for a double-ported valve, only it is carried further. The steam valves are also gridiron valves, and are provided with riding cut-off valves, under

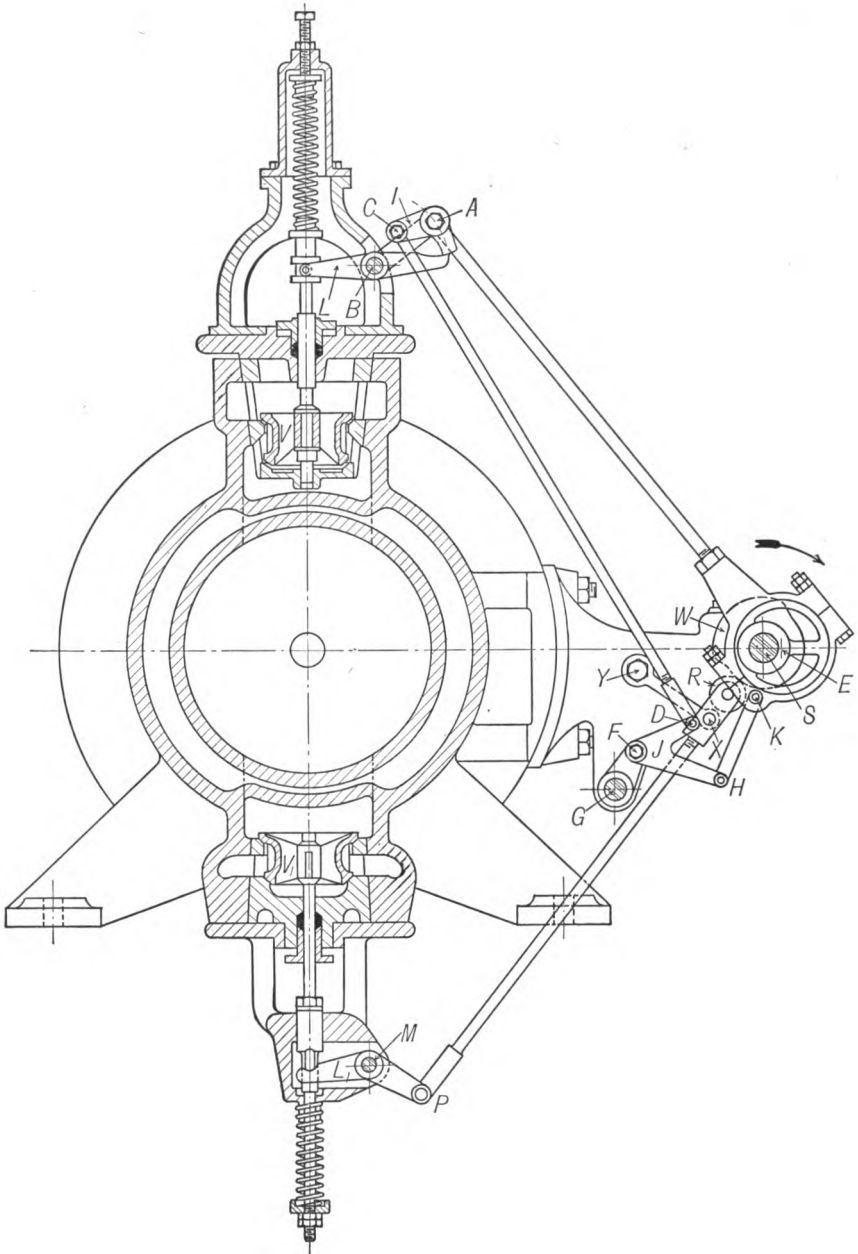

FIG. 129. Sulzer Valve Mechanism.

control of a flywheel governor. The valves are driven through a system of links, rock shafts and slides for transmitting the motion of the eccentrics to the valves. The links and rockers are so arranged that the valves move rapidly when opening and closing and remain practically still when closed.

82. Sulzer Valve Gear. The Sulzer Valve Mechanism is used largely in Europe, and is well adapted for many types of engines. It is a four-valve mechanism. Fig. 129 is a section across the cylinder through one pair of valves. The valves differ from any that we have thus far considered, being of the type known as *poppet* valves. They are circular in form, and open by rising from their seats, thus allowing a large opening for a small movement and avoiding friction due to sliding on a seat. In the figure the exhaust valve V_1 is closed and the steam valve V is open. Both valves are urged shut by helical springs which press against collars on the stems. The valves are operated by the rockers L and L_1 . A shaft S is driven from the engine shaft. On S is an eccentric whose center is at E . This eccentric, by means of the eccentric rod, swings the link BA about the pin B which is also the axis of the rocker L . As the eccentric draws the pin A downward the right end of the rocker L is pushed down by the toe of the bent rocker I which is pivoted at A . The left end of L is attached to the valve spindle which is, therefore, raised, opening the valve. Attached to the pin C on the rocker I is the long link, CD , taking hold of the rocker J . This rocker swings about the pin F , the position of which is controlled by the governor operating the shaft G . The rocker J is moved about F by the link HK which connects H with the pin K on the eccentric strap. The effect of this linkage $KHFDC$ is to swing I about A at the same time that A is being drawn down by the main eccentric rod. When I has turned about A far enough to allow the toe to slip off the end of L , the spring forces the steam valve shut almost instantly. As the engine speed increases, the governor turns the shaft G to lower the pin F . This causes the toe of I to slip off L earlier and produces an earlier cut-off.

The exhaust valve is opened by the rocker L_1 . This rocker is operated by the cam W on the shaft S acting on the roller R which is on the end of the long rod taking hold of L_1 at P . The upper end of this rod is guided by the link XY swinging about the fixed center Y .

CHAPTER VIII

HAND-OPERATED REVERSING AND CONTROLLING GEARS

83. The valve mechanisms previously discussed have, for the most part, been those used on stationary engines. Such engines always run in the same direction, and at practically a constant speed. The governing devices for controlling the steam supply as the load varies are automatic so that little attention is required when running.

On marine, locomotive, and other moving engines it must be possible to quickly change the speed and direction of turning and to adjust the steam distribution at will. The same is true of some small stationary engines, such as hoisting engines. This control is accomplished by hand or, at least, at the will of the operator. The same mechanism usually controls the steam distribution and the direction of rotation.

84. **Link Mechanisms.** In Fig. 130, if E is the center of the eccentric and the eccentric rod is directly connected to the stem of a valve taking steam on the outside, the engine crank will turn in the direction indi-

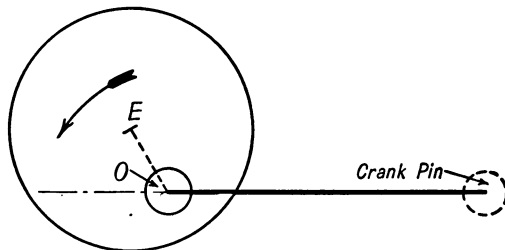

FIG. 130.

cated by the arrow. Should the eccentric be shifted to the position E_1 , Fig. 131, the direction of rotation would be reversed. If now, instead of shifting the position of the eccentric, two eccentrics are provided as shown in Fig. 132, and provisions made for connecting either one to the valve, the direction of rotation will be that shown by the full arrow or by the dotted arrow according as the full eccentric or the dotted one is connected to the valve.

Fig. 133 suggests a method by which this was sometimes accomplished in the early days. Each eccentric rod was provided with a hook which could be attached to a pin on the valve stem. When the eccentric rod

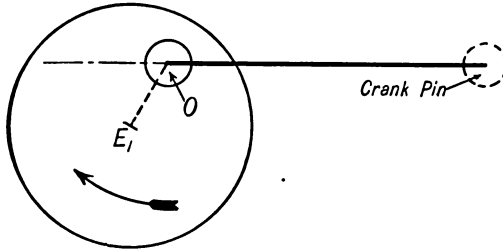

FIG. 131.

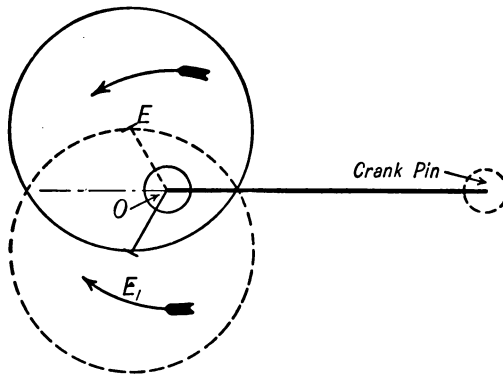

FIG. 132.

A was hooked on, the direction of rotation was as indicated by the arrow. To run in the other direction the linkage must be raised to attach the

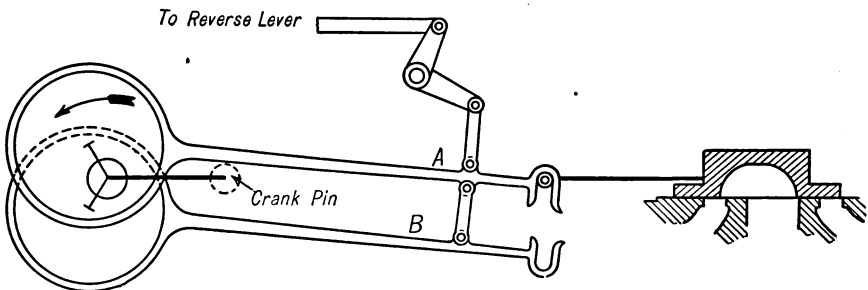

FIG. 133.

other hook to the pin; a process which was, evidently, inconvenient. The natural development was to unite the two hooks into one piece as suggested by the dotted lines in Fig. 134. The resulting mechanism,

shown in Figs. 135 and 136, is known as the Stephenson Link Mechanism. The general operation of the mechanism is evident. In the position of the link shown in Fig. 135, the "forward" eccentric is con-

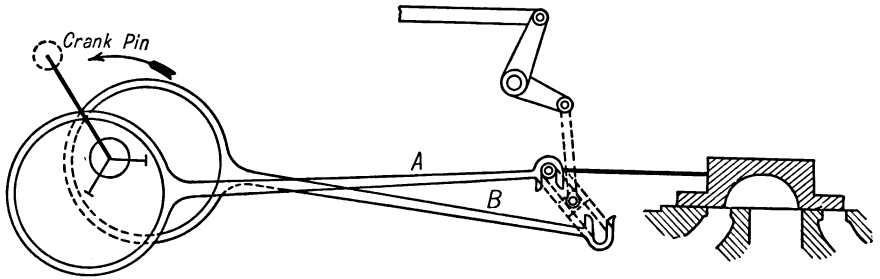

FIG. 134.

trolling the valve. When raised to the position shown in Fig. 136 the "backing" eccentric controls the valve. When set in some intermediate

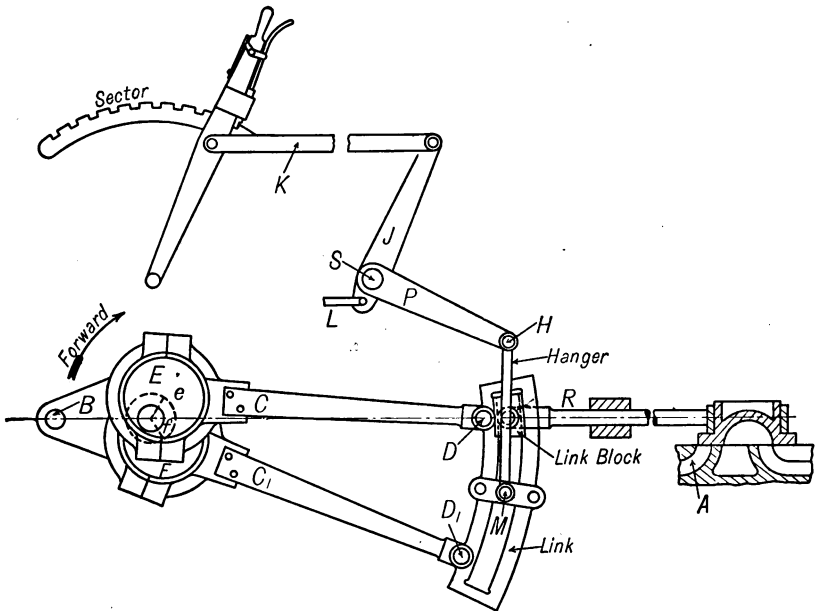

FIG. 135. Stephenson Link, Full Gear Forward.

position the motion of the valve is due to the combined effect of both eccentrics, the result being a change in cut-off and other events of the stroke somewhat similar to that obtained by a shifting eccentric.

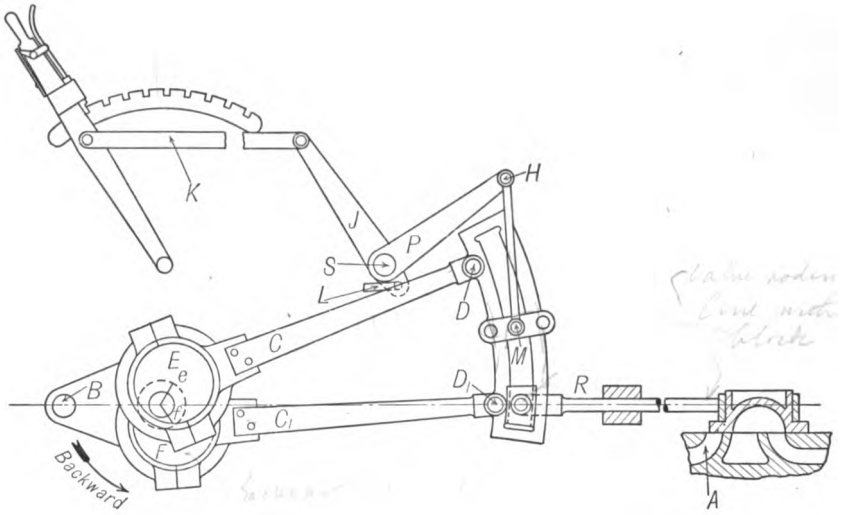

FIG. 136. Stephenson Link, Full Gear Backing.

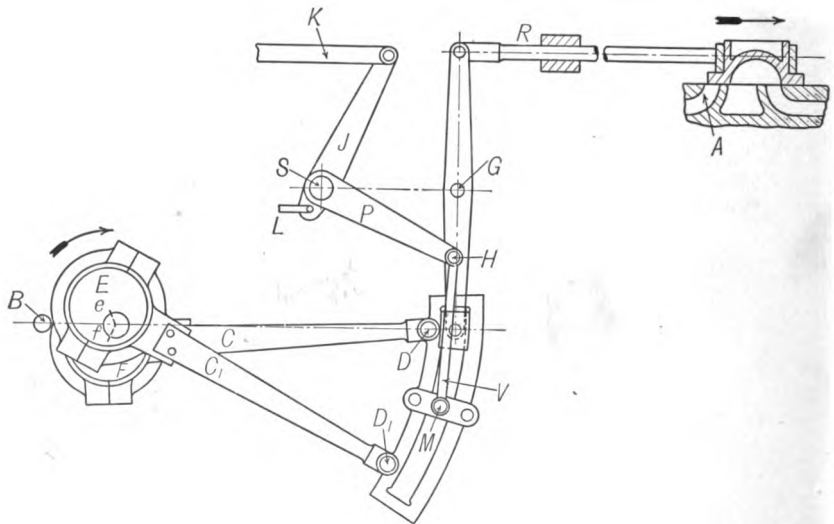

FIG. 137. Stephenson Link with Rocker, Full Gear Forward.

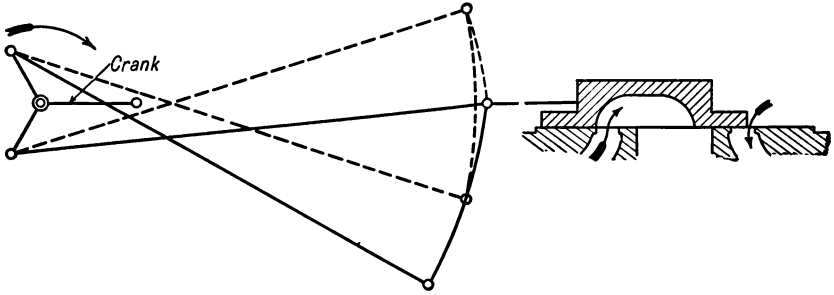

FIG. 138. Increasing Lead.

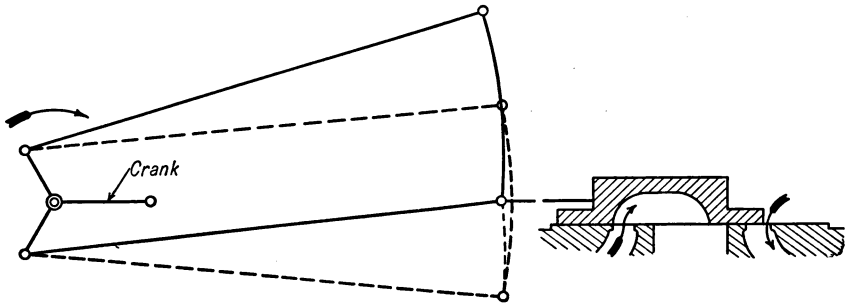

FIG. 139. Decreasing Lead.

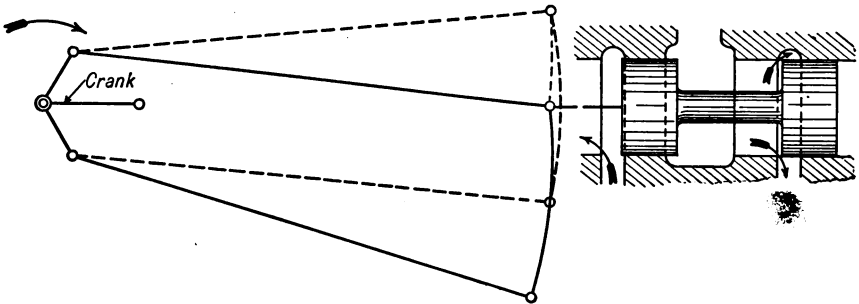

FIG. 140. Increasing Lead.

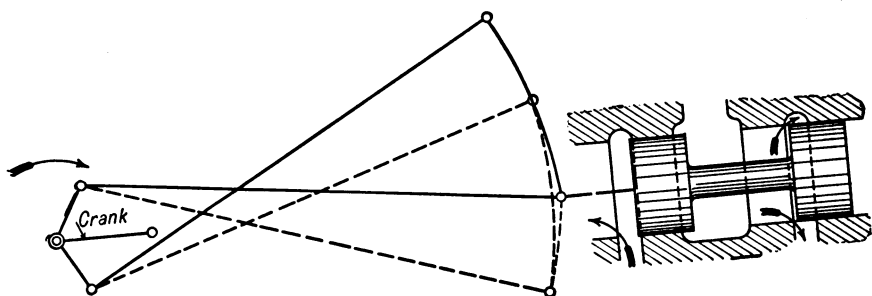

FIG. 141. Decreasing Lead.

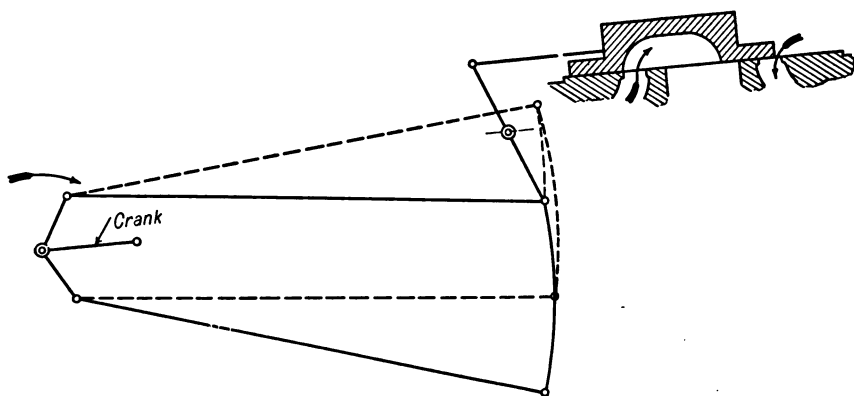

FIG. 142. Increasing Lead.

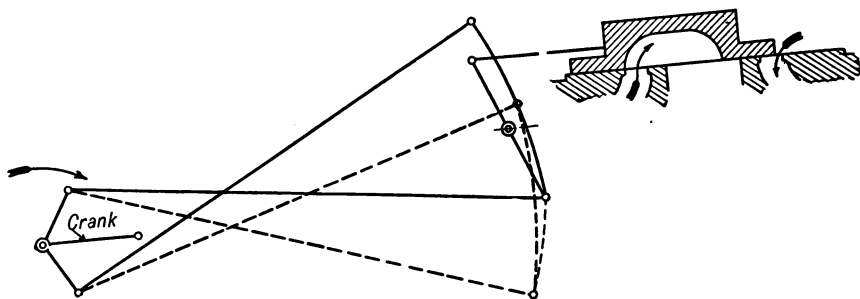

FIG. 143. Decreasing Lead.

85. Link with Rocker. Fig. 137 shows a Stephenson link driving the valve through a rocker. The essential difference here is that each eccentric is shifted 180° from its former position relative to the crank.

86. Increasing and Decreasing Lead. There is a vital difference in

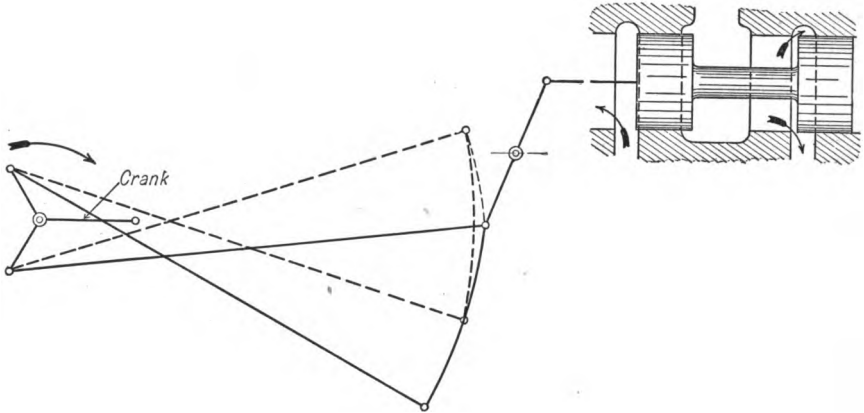

FIG. 144. Increasing Lead.

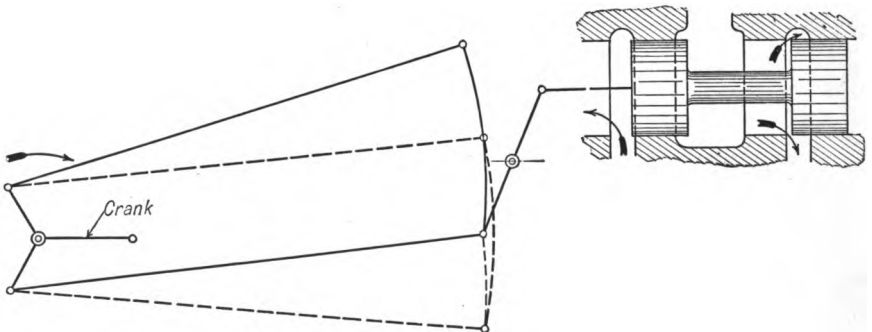

FIG. 145. Decreasing Lead.

the manner in which the eccentrics may be connected to the link. This difference manifests itself particularly in its effect on the lead. Figs. 138 to 145 show the change in the lead as the cut-off is shortened. It will be noticed that in every case *where the lead increases as the gear is hooked up to shorten the cut-off, the eccentric rods are uncrossed or open*

when the eccentrics are toward the link, as in Fig. 146, and where the lead decreases the rods are crossed when the eccentrics are towards the link, as in Fig. 147.

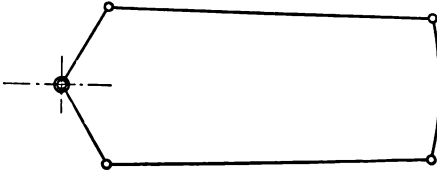

FIG. 146.

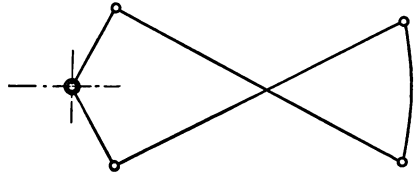

FIG. 147.

The position of the eccentrics relative to the crank depends upon the type of valve (that is whether it takes steam on the outside or inside) and upon the connection, whether direct or through a rocker.

87. Radius of Slot in Link. It can be shown that if the radius of the center line of the slot in the link is equal to the length of the eccentric rod the lead will be alike on both ends. In this connection, the length of the eccentric rod is understood to be the actual length from the center of the eccentric to the center of the link pins D and D_1 plus or minus the distance that the link pin is back or forward of the center line of the slot.

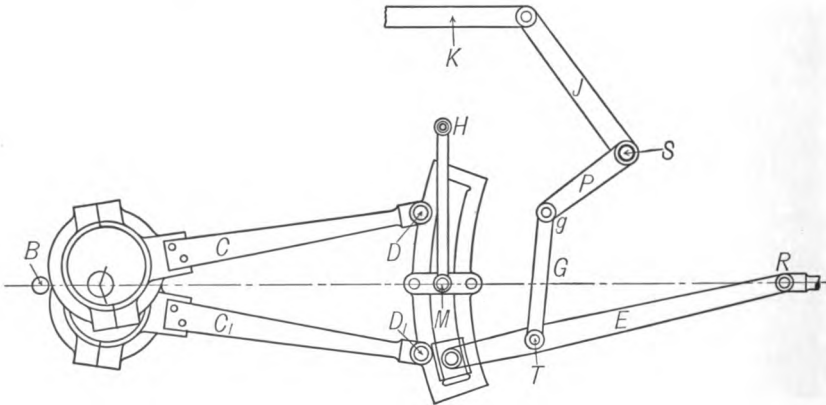

FIG. 148. Gooch Link.

88. Gooch Link. Another form of link mechanism similar in principle to the Stephenson, but differing in detail, is the Gooch link shown in Fig. 148. Here the link is suspended from a fixed point H , and the block is attached to the valve stem by the rod E , known as the radius rod. Instead of raising or lowering the link to change the cut-off or to

reverse, the block is moved up or down in the slot. It is possible to design this link to give constant lead by making the radius of the center of the slot equal to the length of the radius rod.

89. Allan Link. In the link mechanism known as the Allan Link the link itself is straight. There is a radius rod as in the Gooch Link, and both the link and the radius rod are suspended from arms on the reverse shaft in such a way that when the reverse shaft is turned, part of the adjustment is given to the link, and part to the link block. The link being straight instead of curved is cheaper to make, and for this reason is still used to some extent on small engines.

90. Radial Valve Gears. Another type of mechanism for reversing and hand control of steam distribution includes such gears as the Walschaert, Hackworth, Marshall and Joy. These are sometimes called radial valve gears. While these gears rarely have more than one actual eccentric, and often none, the valve motion is approximately that which would be given by the combined action of two eccentrics, one with 90° angular advance, that is, directly opposite the crank or coinciding with the crank according to the type of valve and connection, and giving to the valve a movement either side of mid-position equal to the lap plus the lead. This motion is combined with that from another eccentric, or its equivalent, at right angles to the crank which imparts enough additional motion to the valve to give proper port opening. The connection between this second eccentric and the valve is through some system of adjustable levers and links, by means of which the action of the valve may be changed to give different grades of cut-off or to reverse the direction of rotation of the engine. These gears, as ordinarily designed, give constant lead for all grades.

91. Walschaert Valve Gear. The most important of the so-called radial gears is that invented by Egide Walschaerts in Brussels, and patented in his name in 1844. This has been the type of valve mechanism used on locomotives in Europe for many years, but only recently has it come into general use in this country. At the present time, it is being very generally applied to large locomotives here. Fig. 149 shows the mechanism applied to a locomotive having a plain *D* valve, and Fig. 150 shows it applied to a locomotive with an inside-admission piston valve.

The principle of operation of the mechanism, and the way it may be assumed to have developed from the simple gear driving a valve through a rocker directly from a single eccentric, may be understood from the

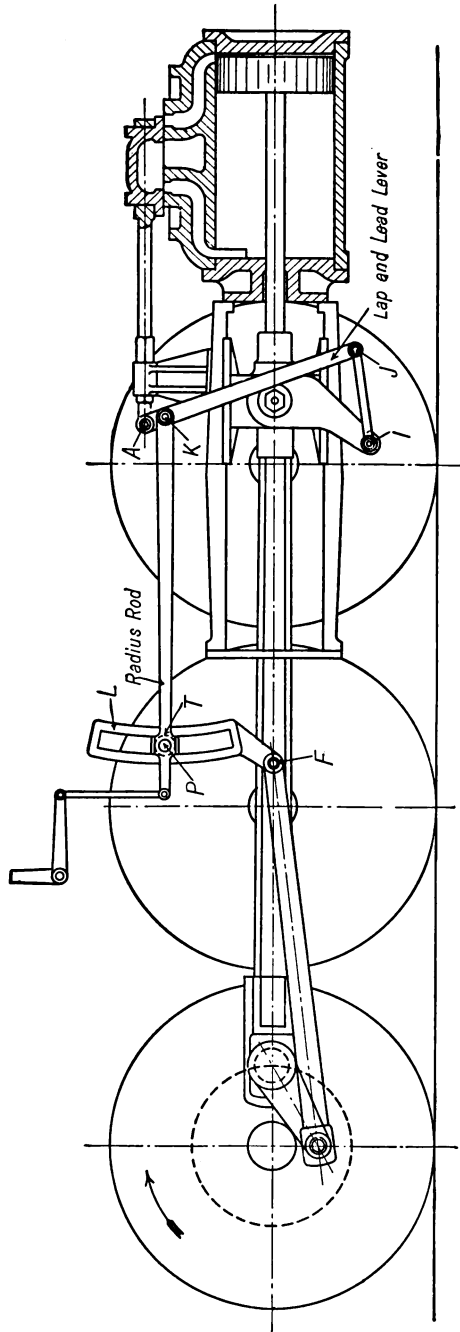

FIG. 149.

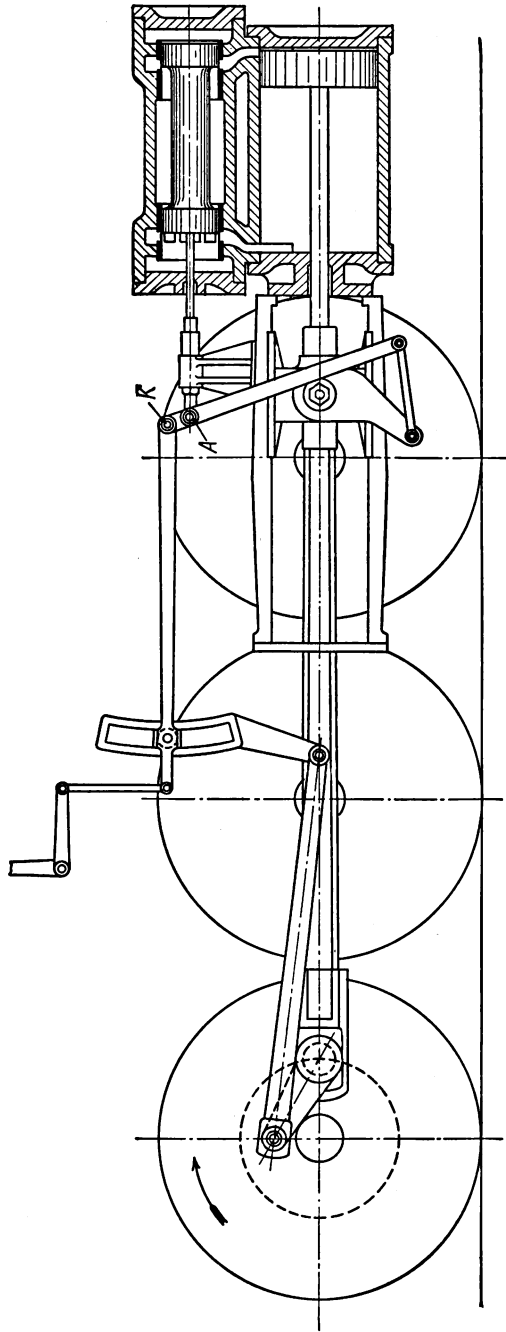

FIG. 150.

following discussion. In Fig. 151 let E be the center of a pin on the return crank CE . This return crank is essentially one piece with the crank proper, extending out to carry the pin E . The center of E is, therefore, equivalent to the center of an eccentric having eccentricity OE set at an angle of 90° with the crank OC . TP is a rocker swinging about the point T which is fixed to the frame. The rod PA connects the pin P on the rocker to the end of the valve stem. The valve is a "square" valve having neither steam nor exhaust laps. The mechanism is, therefore, a simple eccentric 90° ahead of the crank driving a slide valve through a non-reversing rocker.

The engine, evidently, would not start in this position, but if turned slightly in the direction of the arrow, the valve would move to open the head-end port for admission, and the engine would run in the direction of the arrow, taking steam the full stroke. If now we substitute for the rocker TF the slotted link shown in Fig. 152, still keeping its pivot at T , put a block on the rod AP to fit into the slot in the link, and provide means for supporting the end S of the rod, we can raise the block to any desired point in the slot. As it approaches the pivot point the travel of the valve decreases, changing the steam distribution. If P is carried above T , the direction of motion of the valve is reversed, and will be right to run the engine in the reverse direction. In other words, by making the position of the pin P adjustable, we have provided a means for controlling and reversing the engine.

In order to secure admission, cut-off, release and compression at such points in the stroke as give most advantageous operation of the engine, the valve must be given laps. But if it has laps and is driven by a single eccentric, the eccentric cannot be at 90° with the crank, because admission will come too late. The eccentric might be set more than 90° with the crank, if the engine were to run always in the same direction, but setting it ahead to adjust the events for running in one direction would make matters still worse when running reversed. Consequently, the main eccentric is kept at 90° with the crank, and another eccentric or some equivalent mechanism is introduced to cause the valve to be displaced in the proper direction, the lap plus the lead, when the crank is at the dead points. In Figs. 149 and 150 the radius rod, instead of being attached directly to the valve stem, is attached to the rod JA , known as the combining lever or lap and lead lever. The upper end of the lap and lead lever is attached to the valve stem, and the lower end is connected by the union link JI to the crosshead. In the figure, the

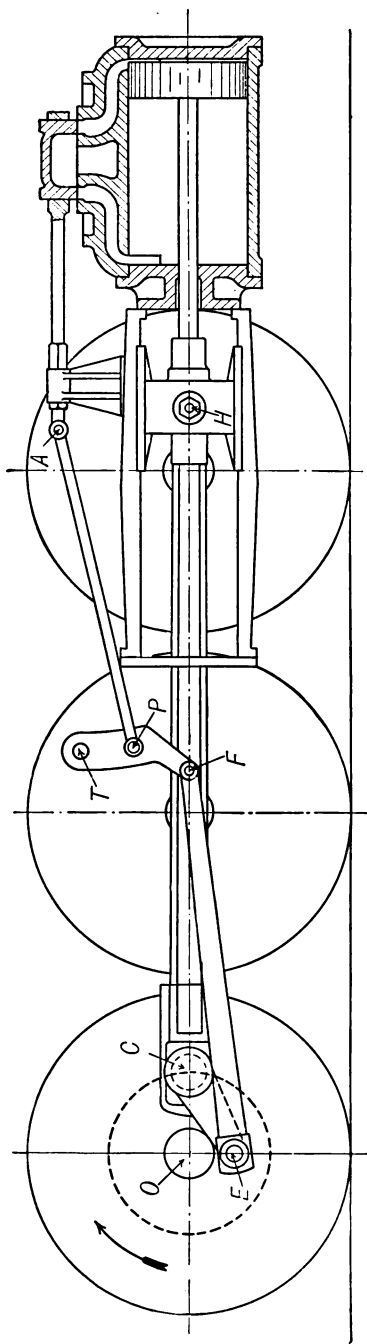

FIG. 151.

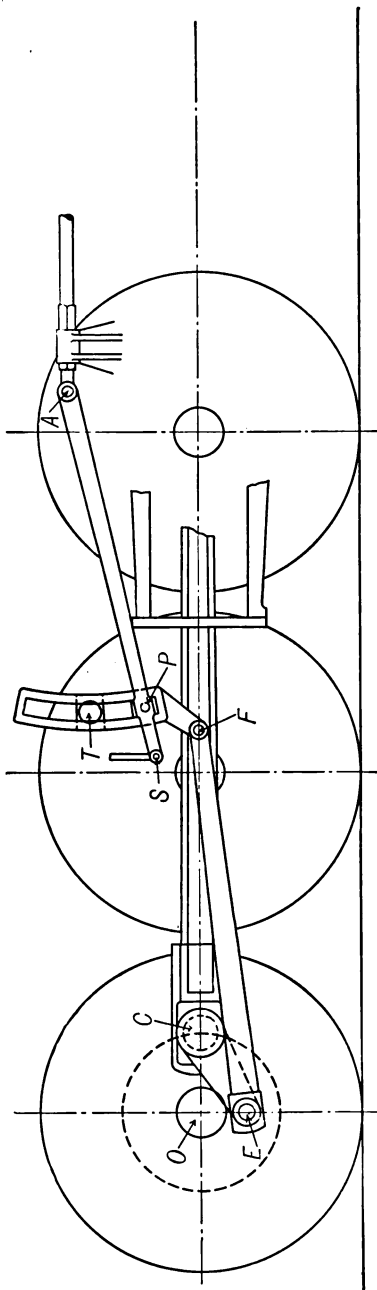

FIG. 152.

radius rod is held by the lifting link in such a position that the pin P is opposite the trunnion T about which the link L rocks. The motion of L , therefore, has no effect on the valve, and K is practically a fixed point. If the crosshead moves back and forth, the lap and lead lever rocks about K , and causes the valve to travel a total distance equal to the sum of the steam laps plus the sum of the leads. This is accomplished by so locating the point K on the lever that

$$\frac{KA}{KJ} = \frac{\text{Sum of laps} + \text{Sum of leads}}{\text{Crosshead Travel}}$$

When the gear is set in this way, it is in mid gear, and while the engine, perhaps, would not start with this setting it might run, if already in motion, in either direction. As soon as the radius rod is lowered, the rocking of the link imparts motion to K , thus giving a corresponding motion to the valve in addition to that which it already has. When the block is down, the engine will run in the direction of the arrow, and when the block is above the trunnion, the engine will run in the reverse direction. In Fig. 150, the valve is an inside-admission piston valve and its motion must be the reverse of that for the valve in Fig. 149. Therefore, the point K , where the radius rod takes hold of the combining lever, is above the end of the valve stem, and if the block is still to be in the lower part of the link when running forward, the return crank pin E must be 180° from the position which it occupied in Fig. 149.

The layout of a Walschaert gear is more or less a matter of trial. Many minor locations may be varied in the design such as the position of F or T , and in this way modifications in the action of the valve may be accomplished. The most satisfactory way to study the design of this gear, as well as the Stephenson link, is by means of a small model which may be used on the drawing board, and in which the proportions may be varied at will, and the resulting action of the valve studied.

Fig. 153, taken from a pamphlet published by the American Locomotive Company, shows the gear at the different events of the stroke.

92. Hackworth Valve Gear. Fig. 154 shows the Hackworth Valve Gear as used by the C. W. Hunt Co. on hoisting engines. E is the pin of a return crank, equivalent to an eccentric with eccentricity OE , in line with the crank, giving a valve motion equal to the steam lap plus the lead each side of mid-position. The lower end of the lap and lead lever EDP slides in a straight slot in the piece L , which may be tipped at various angles about the trunnion T . When the slot is vertical, the

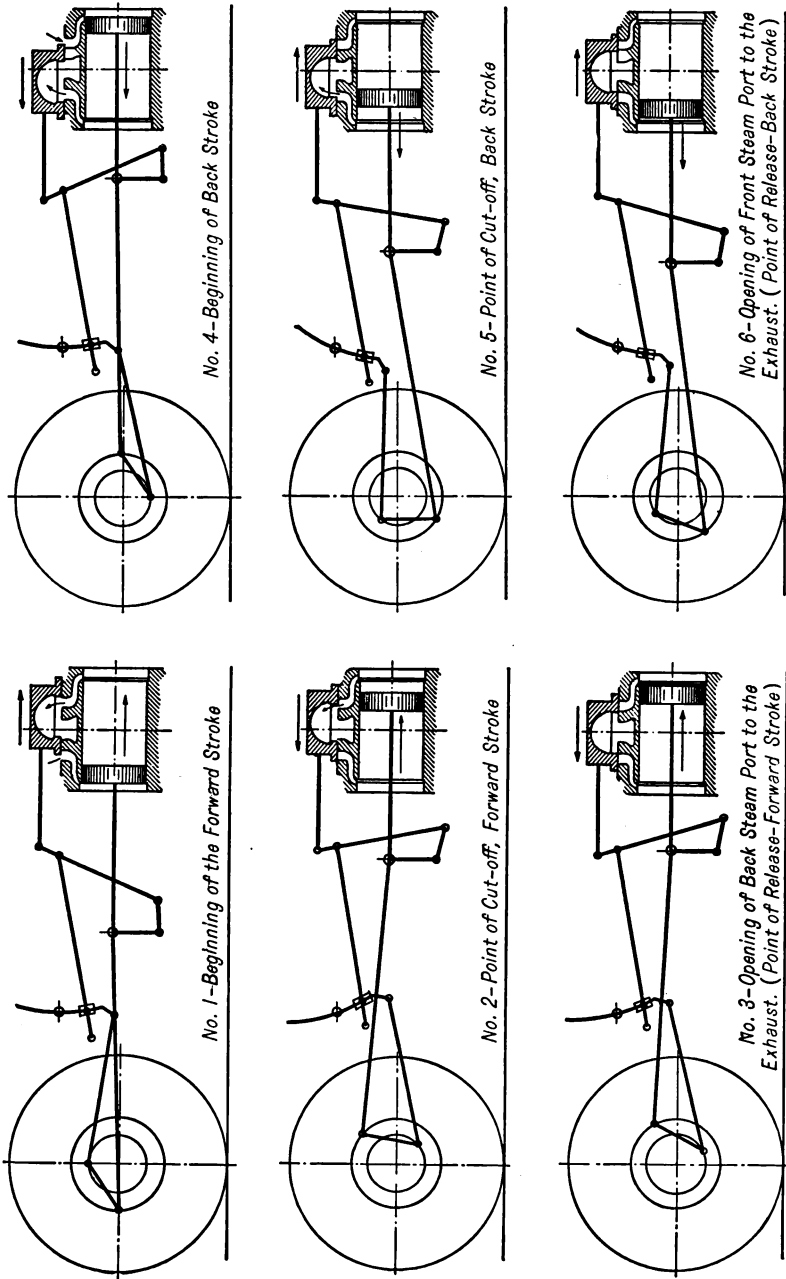

FIG 153.

linkage is in mid gear, and the engine may be made to run in either direction by inclining L either side of the vertical. The valve shown here is essentially a plain slide valve except that it oscillates instead of sliding in a straight line.

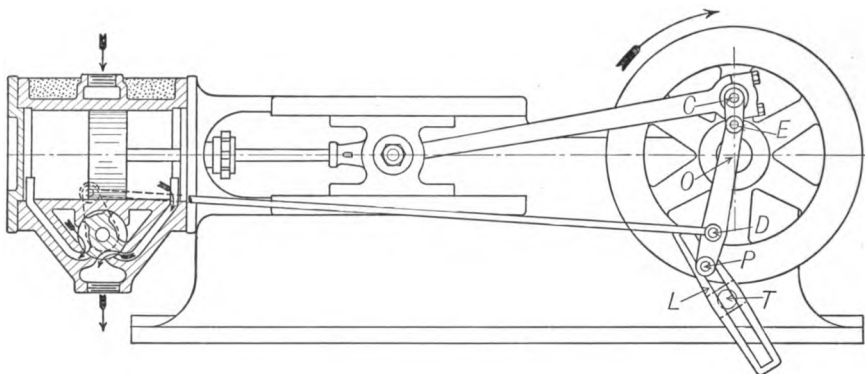

FIG. 154. Engine with Hackworth Valve Gear.

93. Marshall Valve Gear. Fig. 155 illustrates the Marshall Gear. This is similar to the Hackworth except that the point A instead of be-

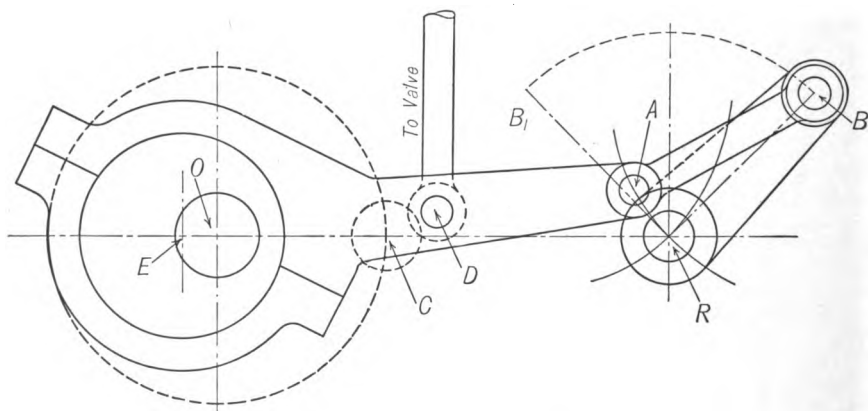

FIG. 155. Marshall Valve Gear.

ing guided in a straight slot is guided in an arc of a circle by the link BA . The pin B is carried by the arm RB , R being the reverse shaft. Grades of cut-off are obtained by turning the reverse shaft to carry B nearer the

vertical line. When B passes the vertical reversal is obtained, full gear backing being with B at B_1 .

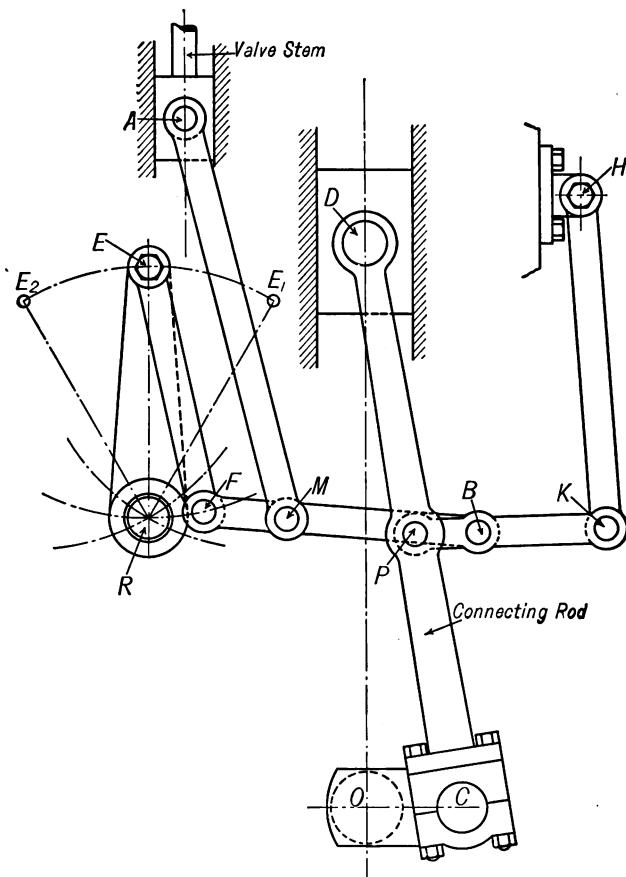

FIG. 156. Joy Valve Gear.

94. Joy Valve Gear. Fig. 156 shows a linkage known as the Joy Valve Gear, which has been used to a considerable extent, and which some authorities think will come into use again, although it is not often seen at present.

CHAPTER IX

VALVE SETTING

95. However carefully a valve mechanism may be designed, or however accurately it may be constructed, some adjustment must be made before the engine can run satisfactorily. Also the angle between crank and eccentric, which may be plainly shown on valve diagrams, must be found by trial on the actual engine. Nearly all valve gears are provided with various adjustments, and the process of adjusting the gear is called, "setting the valves." In setting valves, the engine is usually turned over by hand, the use of crowbars and jacks being necessary in the case of large engines, although often the final adjustment is made by use of the indicator. Reference will be made to this method later.

96. Finding the Dead Points. Since the lead and piston positions for the events of the stroke are all referred to the dead points, it is necessary that we should be able to set the engine exactly on the dead points. It must be remembered that while the piston is moving slowly, when near the dead points, and, consequently, some error in placing the crank would give practically no piston motion, yet the valve is moving rapidly at this time; hence the necessity for being able to determine both dead points with precision.

Before the actual valve setting is discussed, a method for determining the dead points with accuracy will be given. Suppose it is desired to set the engine on the head-end dead point. Referring to Fig. 157, place the crank pin at *A*, making a considerable angle with the center line. Make a mark on the crosshead, and a corresponding reference mark on the crosshead guide. Take some fixed reference point *R* and mark the point *B* on the flywheel that is at the reference point. A good reference point is a nail driven into a board, and the latter fastened to the floor, so that the point of the nail almost touches the rim of the flywheel. In the diagram, the crank-pin circle is taken to represent the flywheel. Now turn the engine in the direction of the arrow until the crosshead has moved to the end of its travel and then back to its former

position, as indicated by the reference marks. The crank pin is at A_1 , the point B has moved on to B_1 , and a new point B is opposite the reference point.

A point not to be overlooked is that allowance must be made for backlash, or lost motion, in the parts. As the crank, when moved from A ,

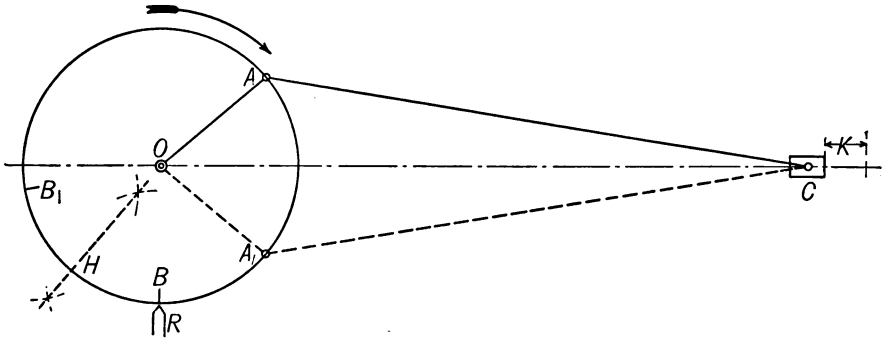

FIG. 157.

is pushing the crosshead, thus taking up lost motion in one direction, so when we find A_1 , we must take up the lost motion in the same direction, that is, must push the crosshead. This is done by turning the crank somewhat beyond A_1 and then turning back to this position.

Having now the points B and B_1 marked on the flywheel, if this arc is bisected the point H is obtained. If H is placed at the reference point, making allowance for lost motion, the engine is on the head-end dead point. The crank-end dead point can be found in a similar manner.

In setting valves, many different cases arise, single-valve engines with fixed eccentrics, single valves controlled by governing devices, single valves controlled by reversing devices, riding cut-off valves, multiple valves, controlled by an almost infinite variety of mechanisms and having almost as many different kinds of adjustments.

While it is not possible to give definite and concrete instructions for setting all valve mechanisms, in a book of this character, yet the fundamental principles underlying all valve setting will be discussed. In some cases, more than one method for doing the same thing may be possible, in which event the method involving the least amount of turning the engine by hand, is usually the preferable one.

97. To Set a Slide Valve for Equal Leads. The first case to be considered will be a slide valve driven by a fixed eccentric designed to give equal lead of a certain amount. The first step is to adjust the length

of the valve stem to give *equal* leads, and the second is to determine the position of the eccentric, relative to the crank, to give the *required* lead.

Loosen the eccentric on the shaft and turn, with its attached valve, until the greatest opening of the port on the head end occurs and measure it. Now turn the eccentric until the greatest opening of the crank-end port occurs and measure that. The port openings will probably be unequal, and must be equalized by changing the length of the valve stem. If the head-end opening is the larger, the stem is too short, if the crank-end opening is the larger, the stem is too long.

Next place the engine on the head-end dead point, and if the engine has a *D* valve, driven direct, place the eccentric about 90° ahead of the crank, in the direction the engine is to run, and move eccentric slowly ahead until the lead opening is the required amount, and fasten the eccentric. If the work has been carefully done, the crank-end lead will be the same as the head-end, but it is well to try the crank-end lead again to insure that no mistake has been made. If the engine has an inside-admission valve or is driven through a reversing rocker, the only difference from the above case will be in the position of the eccentric relative to the crank.

98. To Set a Slide Valve for Certain Desired Cut-offs. Suppose it is desired to adjust the valve mechanism to give cut-off at certain points for head and crank ends. Turn the engine until the crosshead has moved from the head end to the position where cut-off is desired, loosen the eccentric and turn on the shaft until cut-off occurs. Tighten the eccentric and turn the engine until the crosshead has gone the required distance from the crank end; probably cut-off will not be found to come at this point. Now move the valve *one half* the distance necessary to cause cut-off, by changing the length of the valve stem, and the other half of this distance by changing the position of the eccentric on the shaft.

A little thought will show that by changing both valve stem and eccentric, each one half the required amount, the head-end cut-off will remain unchanged while that on the crank end is made to come at the desired point. To make sure of the work, it is well to try the cut-off on the head end again, and see that it does come at the desired point.

99. Valve Setting with a Tram. Valve setting is often done by use of a tram and tram marks on the valve stem. This method is very frequently used on locomotive valves to "true up" an engine that has

become a little "out of square." It recommends itself on account of its simplicity. After the tram is made, and the marks are on the valve stem, the valve need not be seen, and, consequently, the steam-chest cover need not be removed, in order to set the valve.

Fig. 158 shows one form of tram, consisting of a piece of bar steel bent and pointed, and the ends usually hardened.

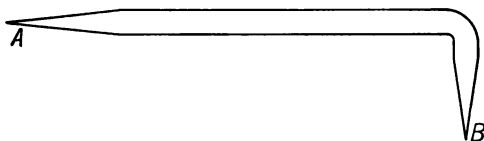

FIG. 158.

The process of getting the tram marks is as follows: A center-punch mark is made on some fixed part of the engine, as the guide yoke or end of the steam chest, and the point *A* of the tram is placed in this punch mark. The valve is next moved until its edge is at the edge of the head-end port, and a punch mark made on the valve stem, into which the point *B* of the tram will fall. It is now known that whenever the point *B* is in this punch mark, the edge of the valve is at the edge of the head-end port. A similar punch mark is made on the valve rod, when the edge of the valve is at the edge of the crank-end port. After these tram marks are made, evidently the valve need not be seen, for a reference to them by means of the tram point, will show just how far either edge of the valve is from its port.

100. Setting Single Valves Controlled by Governing Devices. As in the case of a valve driven by a fixed eccentric, the length of the valve stem must be adjusted and the position of the eccentric found, either to give the desired leads or cut-offs at the desired points. The position of the eccentric may be determined by turning the whole governor wheel and eccentric, on the shaft, until its position is found, and then fastening it there, getting, of course, the setting for full gear (longest cut-off). Again, the position of the governor wheel carrying the eccentric may be determined for one engine, and then jigs used to cut all key ways, and to drill all holes, so that all subsequent governors will be exact duplicates of the first, and will be keyed to the shaft with their eccentrics in the same position relative to the cranks as in the first engine.

Many governors do not use an eccentric, but replace it by a pin, off center, the holes, of course, being drilled in jigs so as to insure exact dupli-

cation. Often this pin, replacing the eccentric, is made eccentric, so that if it is rotated a small part of a turn and clamped in that position, the lead of the engine is increased or decreased. The speed of the engine is determined by the tension of the governor spring, or springs, which tension is always adjustable. It is obvious that the engine must be run under steam to determine if the spring tension is right to give the designed speed.

101. Setting Single Valves Controlled by Reversing Devices. Valve setting with reversing devices is entirely similar to setting valves driven by a fixed eccentric, except that the setting must be made for both full gear forward and backing.

The Stephenson link motion as applied to locomotives of a few years ago had the eccentrics fastened to the axle by set screws, slotted eccentric rods, and a screw adjustment for the length of valve stem. It was soon apparent that under the hard service to which a locomotive is subjected, set screws would slip, slotted eccentric rods would slip, and nuts and turnbuckles back off.

The usual practice today is to place a locomotive on rollers and find the positions for all eccentrics, mark these positions, remove the eccentrics and cut key ways, so that when the eccentrics are replaced, they can be securely keyed in position. After a few years' running, if it is found that, due to wear or other causes, the positions of the eccentrics should be changed, the keys are driven out and off-set keys are put in. Thus the positions of the eccentrics may be changed slightly and still make use of the old key ways.

In the case of a *D* valve, the connection between valve and valve stem is such that no adjustment for the length of the stem is possible. With a piston valve, the valve stem usually passes through the valve, the latter being held against a shoulder on the stem at one end, by a nut at the other. In this case, the length of the stem may be changed by putting washers between the valve and shoulder.

If the length of the eccentric rods is changed, it will be equivalent to changing the length of the valve stem. In modern locomotives, this is accomplished by heating the rods, and drawing them out under a hammer or shortening by upsetting, as the case may be. This is not the crude operation that it might seem, for a skilled blacksmith can change the length down to a hundredth of an inch.

In cases where a rocker is used, the position of the rocker shaft can not be changed after the bolt holes are drilled, except in a vertical direc-

tion. This is accomplished by putting shims under the rocker-shaft box, the valve adjustment thus being changed somewhat.

If properly designed and constructed, a valve driven by the Walschaert gear usually needs but one adjustment, namely the length of the valve stem, or what is equivalent, the length of the radius rod. This may be accomplished by heating and drawing out, or upsetting. The pin eccentric is exactly 90° from the crank, and this can be made just right when the engine is built, by keying the return crank in the correct position.

102. Setting Riding Cut-off Valves. In the case of riding cut-off valves, the practice is to set the main valve to give equal leads of a predetermined amount, exactly as a single valve would be set for equal leads. The riding valve is usually set to give equal cut-off at some point of the stroke, exactly like a single valve. When the riding valve is controlled by a shaft governor, as is commonly the case, the cut-off is equalized at the middle of the governor's range or else at the point where it is expected the engine will run the major part of the time.

103. Setting Corliss Valves. A Corliss gear with a single wrist-plate, may be taken to illustrate the principles of valve setting for all the various types of multiple-valve engines in use. The method of procedure is as follows:

Remove the bonnets covering the ends of the valves. Reference marks will be found on the ends of the valves and seats, giving the positions of the working edges of the valves and ports.

Adjust the length of the eccentric rod so that the rocker will swing equal angles on each side of the vertical.

Next, adjust the length of the reach rod so that the wrist-plate will swing equal angles each side of the vertical.

On the wrist-plate supporting stud a reference mark is usually to be found and two others, indicating extreme displacements, are on the wrist-plate hub. If a mark is made on the hub, mid way between the extreme marks, and then this new mark is brought to the reference mark, the valve gear is in mid-position. Place the wrist-plate in one extreme position, with the dash-pot plunger resting on its seat. Adjust the length of the dash-pot rod so that the claw is past the hook-block, about $\frac{1}{8}\frac{1}{2}$ ". This is called the latch-clearance. Repeat for the other extreme position.

Place the wrist-plate in mid-position, with the steam-arm (*E* Fig. 116) hooked up and give the steam valves the proper laps or clearances,

by adjusting the lengths of the steam and exhaust links. The following table of laps and leads for various size Corliss engines is taken as representative of good current practice:

TABLE OF LEADS AND LAPS FOR DIFFERENT PISTON DIAMETERS

Piston Diameter, Inches	Lead	Steam Lap	Exhaust Clearance
8-14	$\frac{1}{8}$	$\frac{3}{8}$	$\frac{1}{8}$
14-20	$\frac{3}{8}$	$\frac{5}{8}$	$\frac{3}{8}$
20-26	$\frac{1}{4}$	$\frac{3}{4}$	$\frac{1}{4}$
26-32	$\frac{5}{8}$	$\frac{7}{8}$	$\frac{3}{8}$
32-38	$\frac{3}{4}$	$\frac{1}{2}$	$\frac{1}{2}$
38-44	$\frac{7}{8}$	$\frac{9}{8}$	$\frac{3}{8}$

Place the engine on either dead point, the gear being connected up. Turn the eccentric on the shaft until it is about ninety degrees ahead of the crank, and then turn it ahead slowly until the steam valve has the proper lead. Fasten the eccentric on the shaft, and turn the engine to the other dead point. If the previous work has been carefully done, the lead on this end should be the same as on the other. If it is not, it may be made so by changing the length of the steam link; this, of course, affects somewhat the steam lap, but as cut-off is not dependent on the steam lap, this is not a serious matter.

Next, block the governor about half-way up and move the engine ahead until it reaches the point where cut-off is desired for normal lead. Adjust the length of the proper governor reach rod until the stop releases the valve. Repeat for the other end.

Lastly, with the governor in its lowest position, and with the wrist-plate in one extreme position, adjust the safety stop so that the hook-block will not be caught when the wrist-plate swings back. Repeat for the other extreme position.

104. Valve Setting with Steam. Very often valves are set by running the engine under steam and taking indicator cards. To the experienced man, the indicator card tells just what is wrong with the valve adjustment, and changes are made until the best possible card is obtained. It is, of course, necessary to set the eccentric in its approximate position, and to roughly adjust the valve gear before the engine will turn over under steam.

However carefully the valves have been set without using steam, the indicator should always be applied and cards taken before the valve setting is considered complete, and the engine ready to run.

Figs. 159 and 160 show a collection of indicator cards, where an ideal card is given and others, illustrating the effect upon the card, of the most common engine and indicator defects. These figures are useful for reference.

In every well-regulated engine room, the indicator is frequently applied. Thus faults in the valve-gear adjustment, as well as leaking pistons and valves and other defects are quickly noted and corrected.

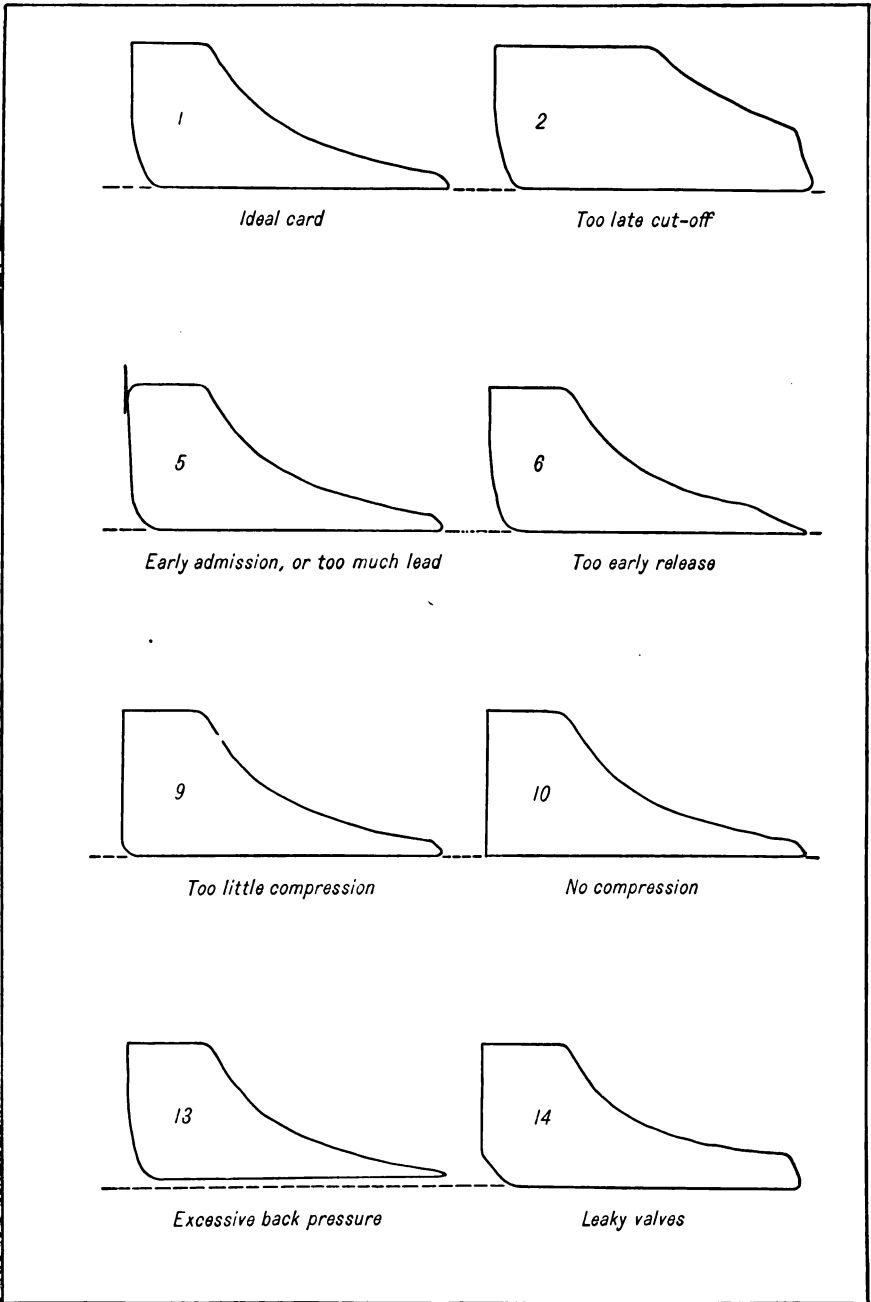

FIG. 159.

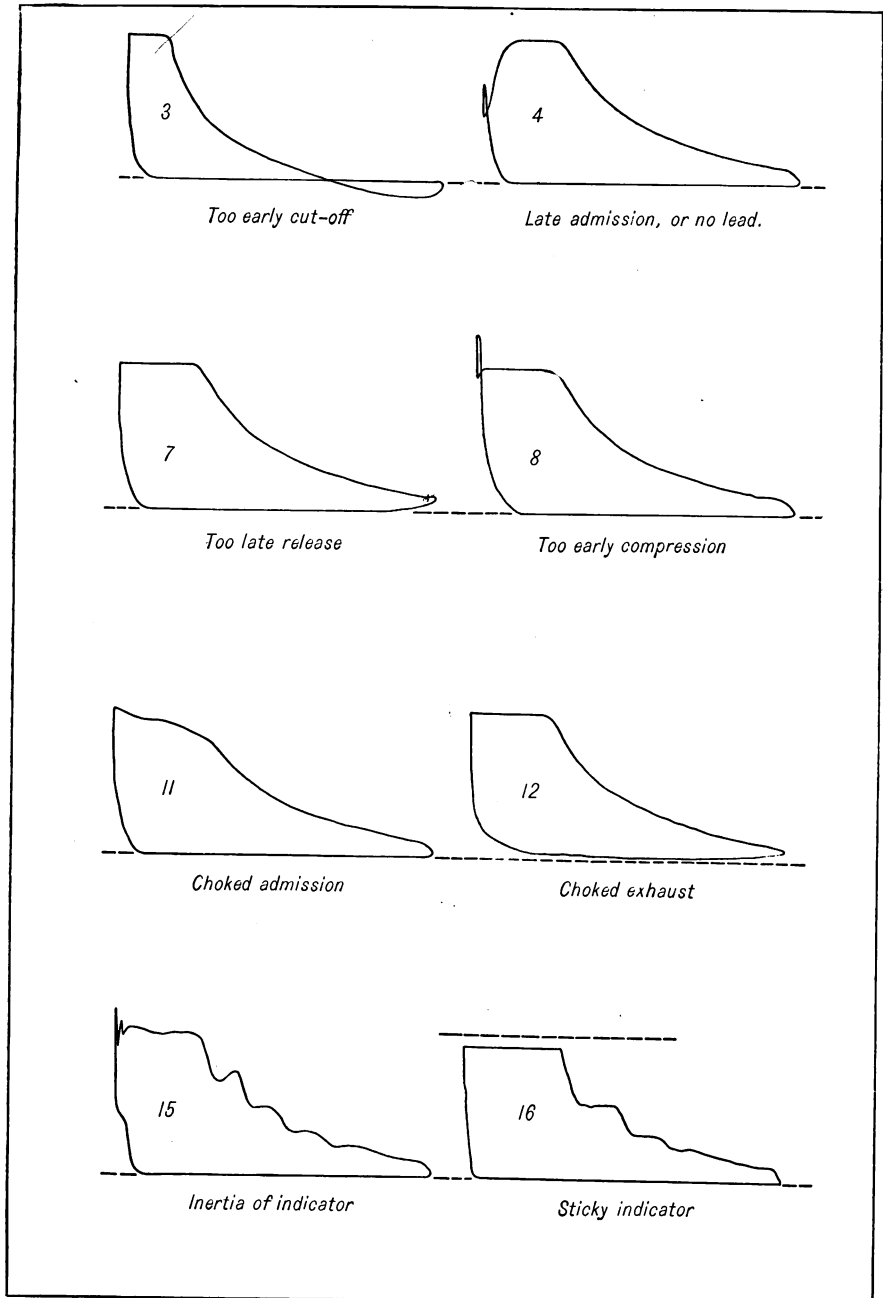

FIG. 160.

CHAPTER X

STEAM TURBINES

105. The steam turbine, like the reciprocating steam engine, is a machine by means of which steam is enabled to do mechanical work. The principle of its action is suggested by the De Laval Trade Mark, Fig. 161. In its simplest form, the turbine consists of a wheel mounted

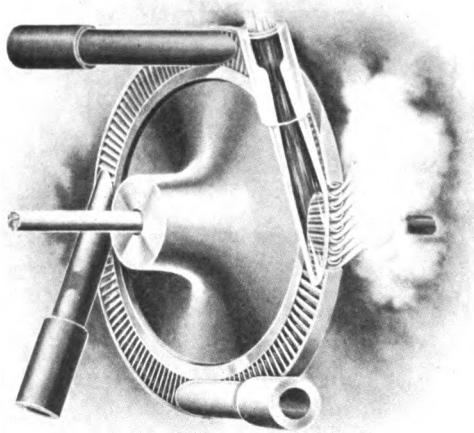

FIG. 161.

on a shaft and enclosed in a steam-tight casing. Around the circumference of the wheel are blades, buckets, or vanes. Steam, directed against these vanes, drives the wheel around. The wheel being fast to the shaft, turns the shaft. Power is taken from the shaft in the same way as from the shaft of a reciprocating engine.

The above is, of course, a very elementary description, for the actual construction of a machine which makes this operation practicable involves many refinements and complications. It is not our purpose to discuss, to any great extent, the theoretical questions pertaining to the

turbine, but rather to consider their general principle of operation, and some examples for the purpose of studying the mechanism of the moving parts.

106. Expansion of Steam. In order to understand the action of the steam in the turbine it is necessary to notice one fact with regard to the properties of steam, without discussing at all the reason for the same. Let Fig. 162 represent a hole through a thick piece of metal into which

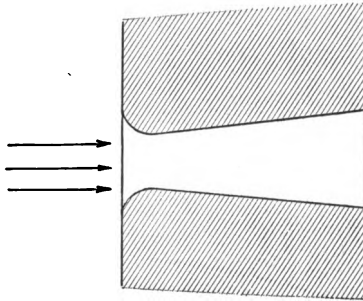

FIG. 162.

steam, under pressure, is flowing as indicated by the arrows. The corners of the opening are rounded at the inlet side to prevent contraction of the steam due to sharp corners. The hole grows larger toward the outlet end, giving a gradual increase of area of cross section. If water were flowing through such a passage as this, the velocity of flow would be decreased with the increase of area of section. With steam, however, the enlargement of section allows the steam to expand, the expansion resulting in a decrease in pressure and temperature with an increase in velocity. In other words, some of the heat energy contained in the steam is, in the process of expansion, transformed into kinetic energy. This property of steam is made use of in driving the turbine wheel.

107. Classification of Turbines. Steam turbines may be classified as follows:

- | | | |
|--|---|--|
| 1. Impulse turbines: | { | (a) Single-stage.
(b) Velocity-stage or velocity-compounding.
(c) Pressure-stage or pressure-compounding.
(d) Combination of velocity-stage and pressure-stage. |
| 2. Reaction turbines. | | |
| 3. Combination of impulse and reaction turbines. | | |

In the impulse turbines, the expansion of the steam takes place in the passages which direct the steam upon the moving vanes of the wheel, so that the steam strikes the wheel with high velocity and drives it by the force of the impact. In the so-called reaction turbines, the steam reaches the wheel at high pressure, expands during its passage through the vanes, and leaves them with high velocity. The force which causes the wheel to turn is partly the impulse due to the velocity with which the steam strikes the vanes and partly the reaction due to the velocity with which the steam leaves the wheel.

108. Single-stage Impulse Turbines. Fig. 163 is an outside view of a single-stage De Laval turbine coupled directly to a centrifugal pump. Fig. 164 is a plan section of a similar machine. The names of the various parts are given beneath the figure. The position of part of the nozzles can be seen by the caps in Fig. 163. Fig. 165 shows a section through one of the nozzles in position and suggests the shape of the vanes and the way the steam is directed into them and issues from them. Fig. 166 shows three buckets and the way they are fastened to the wheel in the De Laval machine.

Part of the nozzles are provided with valves as shown in Fig. 165 so that they can be shut off to reduce the supply of steam delivered to the wheel.

Referring again to Fig. 164, the nozzles are inserted in the wall of the nozzle chamber to which the steam is supplied. The steam rushes through the nozzle, the passage through which is of increasing diameter and of such proportions that the steam expands completely to exhaust pressure before issuing from the nozzle. In expanding, as explained in § 106 it acquires very high velocity, often 3000 feet per second or even more. Striking the buckets as it leaves the nozzles, the steam forces the wheel around. For the best efficiency, the linear speed of the buckets should be one half the speed of the steam striking them. This condition can hardly be fulfilled in practice, for the wheel would have to be excessively large or else the shaft would have to turn at a very high speed. In some machines, where economy of steam is not of prime importance, the speed is cut down to a practical point at the expense of efficiency. In most single-stage turbines, however, the wheel shaft is allowed to run fast, to give nearly the proper bucket speed. The wheel shaft is then geared to the working shaft *Y* as in Fig. 164, with reduction in angular speed through the gears.

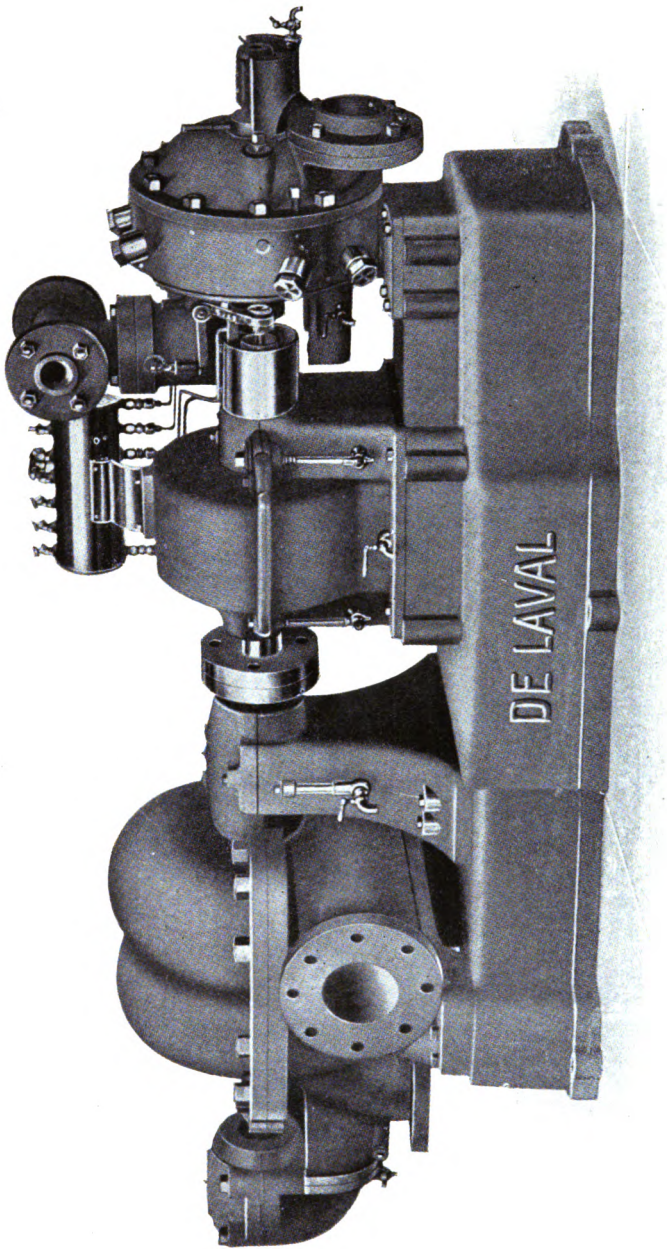

FIG. 163. De Laval Single-stage Impulse Turbine.

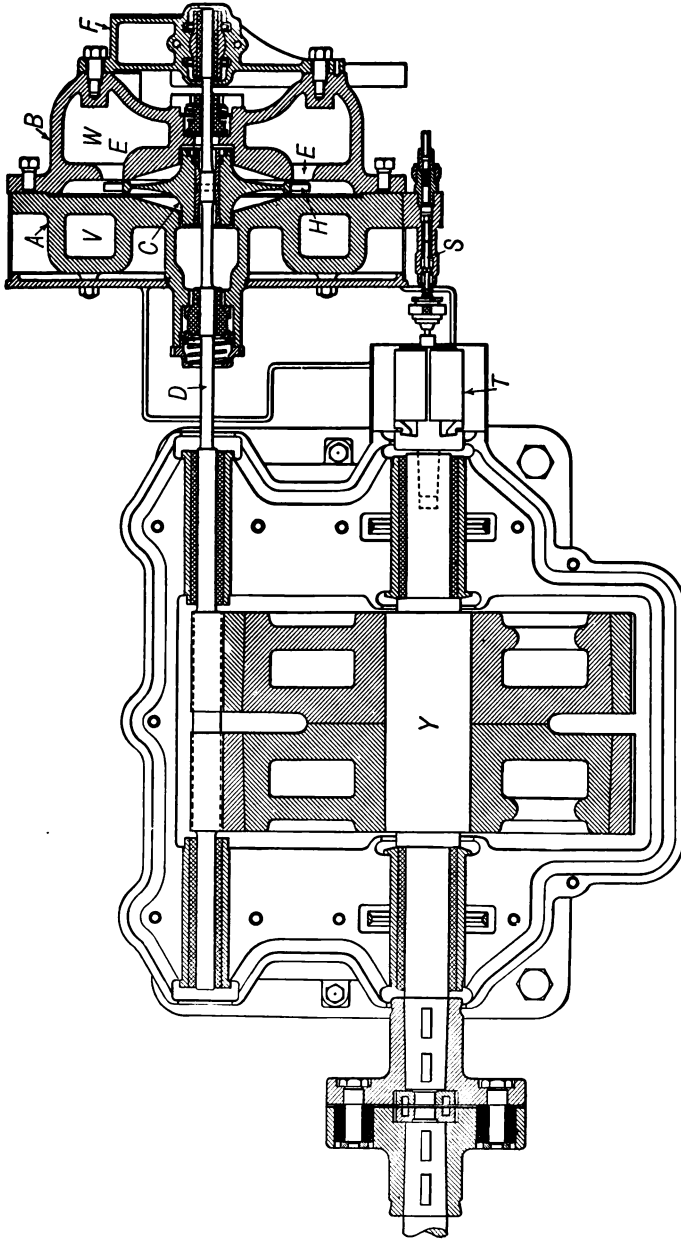

FIG. 164. De Laval Single-stage Impulse Turbine.

- A—Wheel Case
- B—Wheel Case Cover
- C—Turbine Wheel
- D—High Speed, or Pinion Shaft
- E—Passage for Exhaust Steam
- F—Outboard Bearing Bracket
- H—Wheel Buckets
- S—Vacuum Governor Air Valve
- T—Governor
- V—Nozzle Chamber
- W—Exhaust Chamber
- Y—Gear Shaft

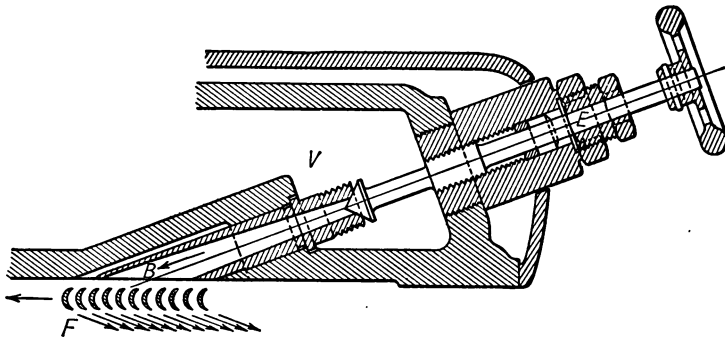

FIG. 165. Nozzle and Vanes for Single-stage Turbine.

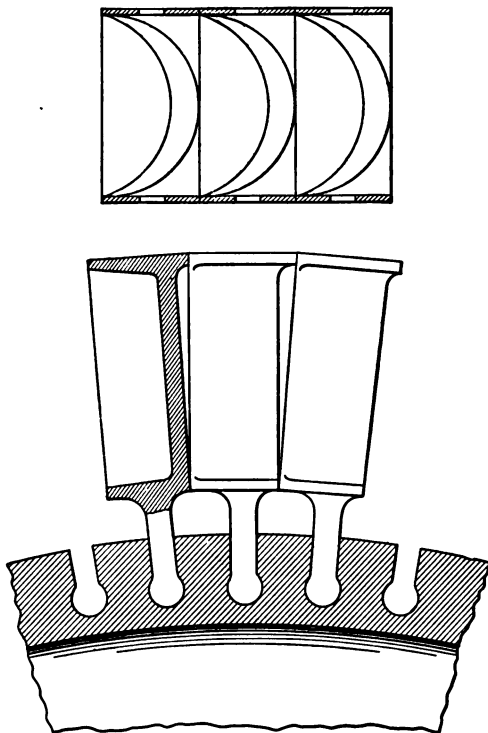

FIG. 166.

109. Velocity-stage Impulse Turbines. Since it is impossible to give to turbine buckets the speed which they should have to use up all of the velocity which steam acquires when it expands through a nozzle from high pressure to atmospheric pressure, the steam necessarily leaves the buckets of a single-stage wheel with considerable velocity, which means

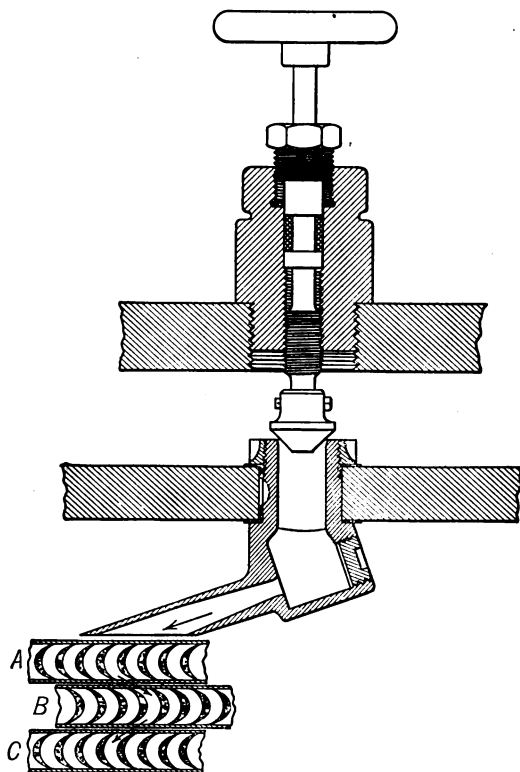

FIG. 167. Nozzle and Vanes for Velocity-stage Turbine.

wasted energy. To save a part of this energy, various methods have been used to direct the steam back upon the same buckets again, or upon another set of buckets on the same wheel. A turbine in which this is done is a velocity-stage or velocity-compounding turbine. Fig. 167 shows the arrangement used in the De Laval velocity-stage turbine. *A* and *C* are two rows of buckets on the turbine wheel. *B* is a row of stationary vanes projecting in from the wheel casing or other stationary support. The manner in which the steam is directed upon the second

set of buckets is evident from the figure. Fig. 168 is a picture of a De Laval turbine having two velocity stages. The same company builds a wheel having three velocity stages.

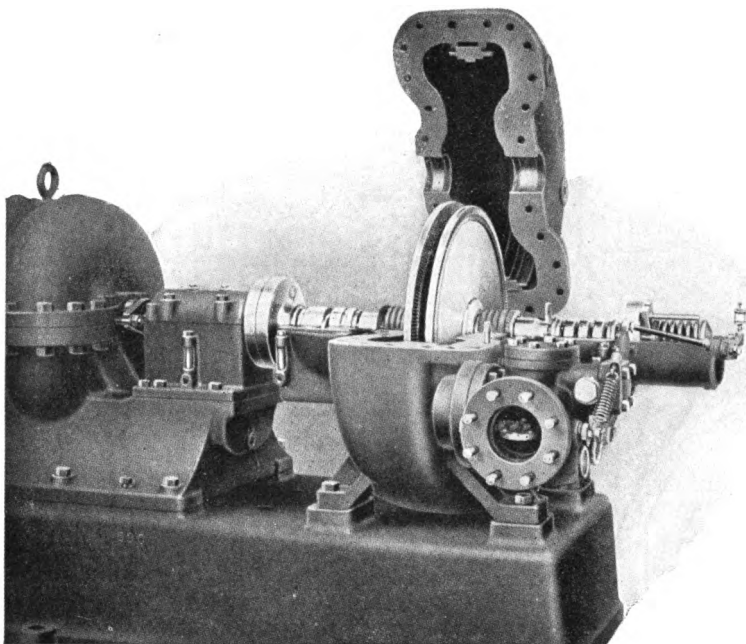

FIG. 168. DeLaval Turbine with Two Velocity Stages.

110. Pressure-stage or Pressure-compounding Turbines. In the two preceding types of turbines, the steam was expanded completely to exhaust pressure in one set of nozzles. In the pressure-stage turbines, there are two or more wheels on the same shaft each in a separate chamber. The steam expands in part only in the first set of nozzles, thus acquiring less velocity and making it possible for the wheel buckets to run more nearly at the proper speed relative to the speed of the steam jet. The first wheel, therefore, runs in a chamber filled with steam under somewhat reduced pressure. In the diaphragm separating the first wheel chamber from the second are nozzles, or passages equivalent to nozzles, through which the steam again expands and is directed against the buckets of the second wheel. The process is repeated as many times as there are stages in the turbine.

Fig. 169 is a section through a Rateau or De Laval turbine having

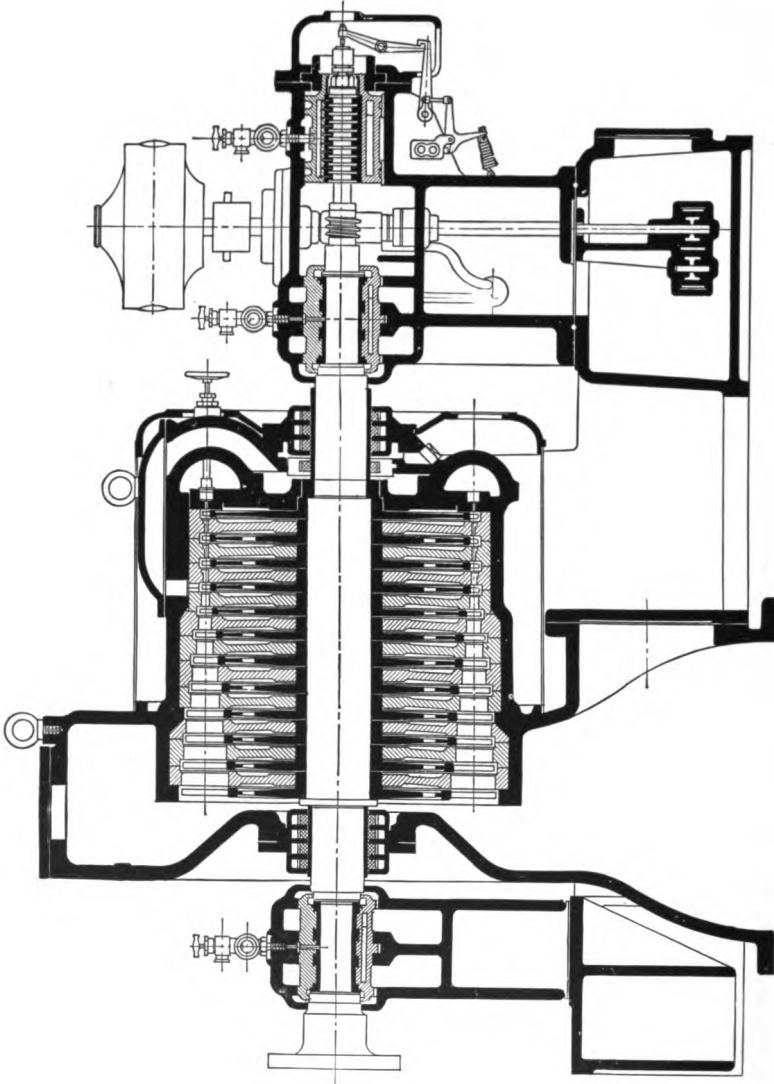

FIG. 169. De Laval Pressure-stage Turbine.

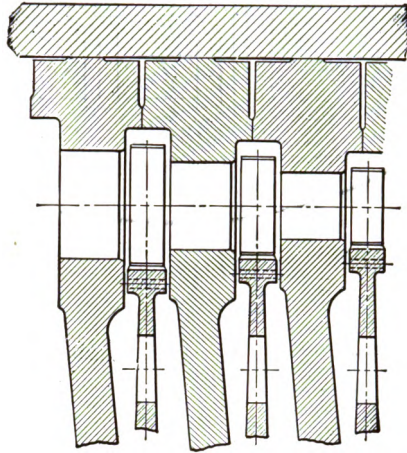

FIG. 170.

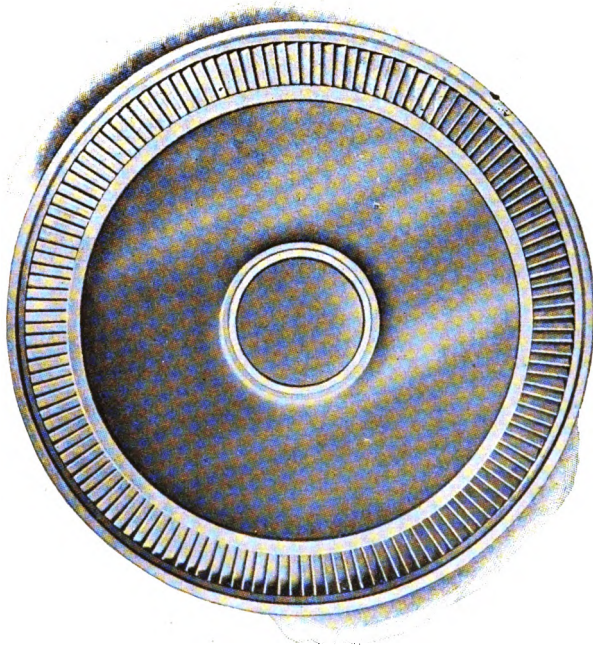

FIG. 171. De Laval Diaphragm.

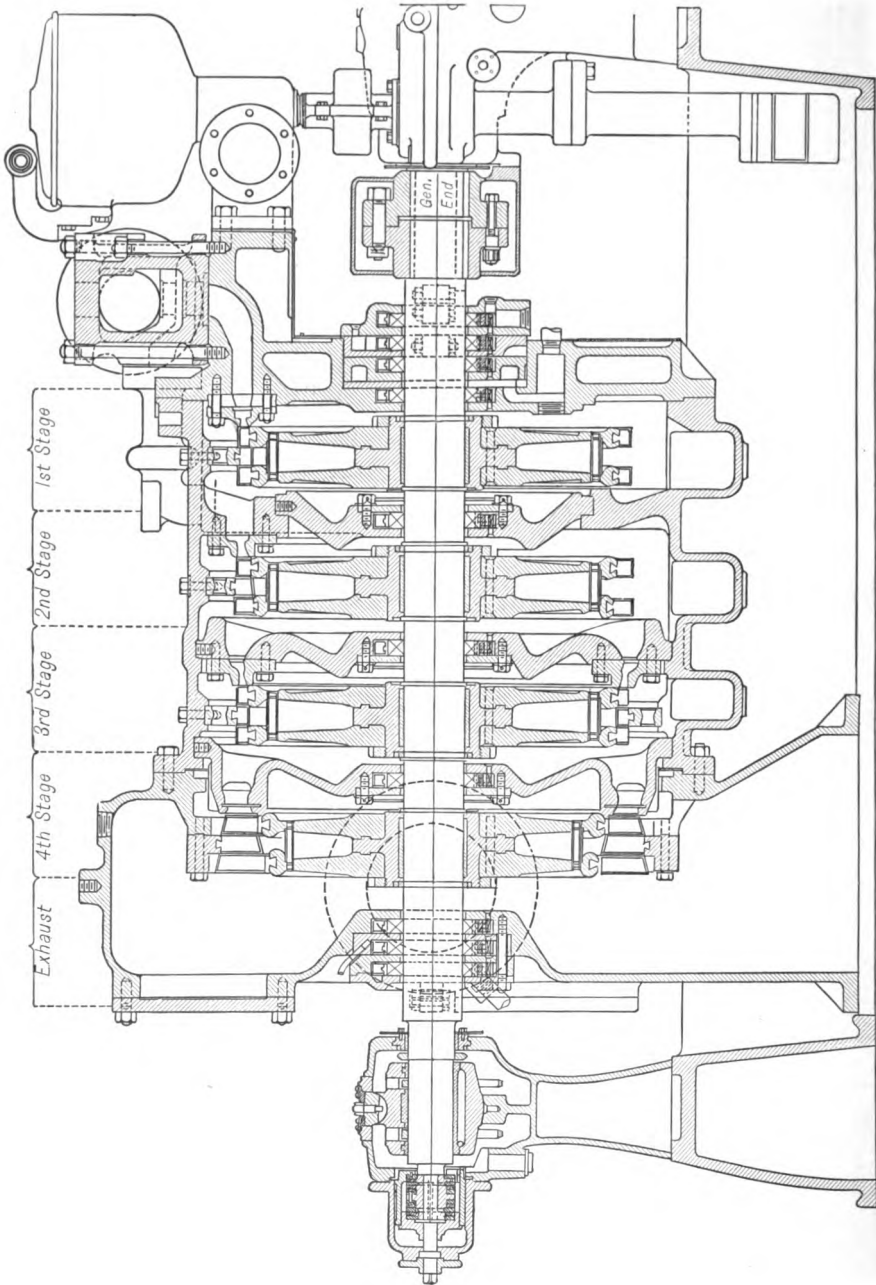

FIG. 172. Curtis Turbine.

twelve pressure stages. Fig. 170 is a section of three wheels and diaphragms near the rim. Fig. 171 is a view of one of the diaphragms showing the openings which serve as nozzles for the second and all succeeding stages.

111. Combined Pressure-stage and Velocity-stage Turbines. In this class of turbines, of which the Curtis, built by the General Electric Company, is a familiar example, there are two or more pressure stages as described in § 110 and each of these pressure stages consists of two velocity stages. Fig. 172 is a section of a Curtis Turbine having four

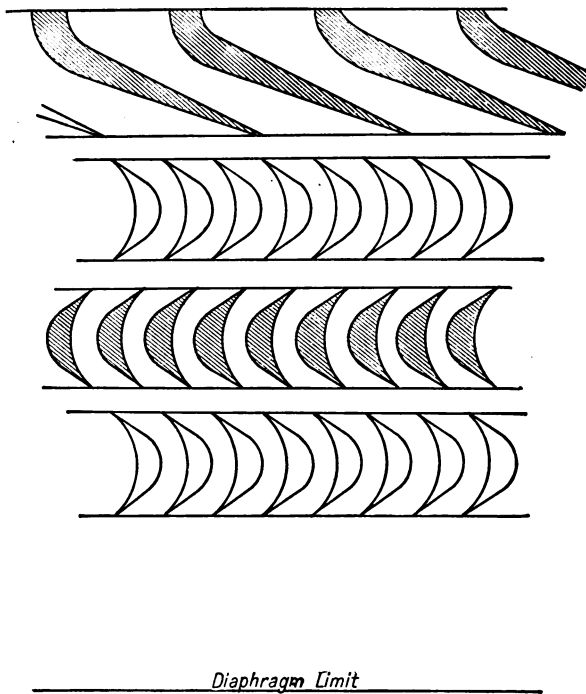

FIG. 173.

pressure stages as indicated at the top of the drawing. Each one of the wheels has two rows of buckets with stationary guide vanes between, giving two velocity stages at each wheel. Fig. 173 shows the form of the buckets and nozzles. The following, taken from the General Electric Company's instruction book will explain the flow of steam in the Curtis turbine:

“Steam is admitted into the turbine casing through the first stage

nozzle, which is of the expanding type and changes pressure energy into velocity energy. The steam pressure on the entrance side of the nozzle is equal to the boiler pressure less the small drop due to steam pipe friction. The steam pressure on the exit side of the nozzle is that of the first stage, usually much less than half the initial pressure, depending on the total number of pressure stages, load, etc. The steam in passing through the nozzle receives a high velocity energy, equal to the 'drop of pressure' energy, and is directed by the nozzle into the first row of buckets in the first pressure stage. The steam in passing through the moving buckets of each stage does so at constant pressure, but with loss of velocity. The direction of the steam is reversed on leaving the first row of buckets, but the steam is redirected by a set of intermediate buckets. It then enters the second row of buckets on the first stage wheel in its original direction and is exhausted into the first stage space. The steam, being at a lower pressure in the first stage space, is greater in volume, so that the aggregate area of the nozzles through which it passes to the second stage is much greater than in the first stage, the buckets being higher and the nozzle arc greater. The second and succeeding pressure stages are in other respects similar to the first."

112. Reaction Turbines. Fig. 174, taken from the Westinghouse-Parsons Instruction Book illustrates the principle of the reaction turbine.

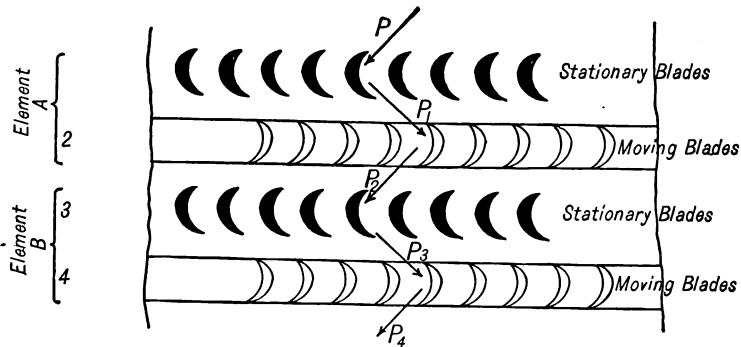

FIG. 174.

The steam, entering the turbine casing through the main admission valve, flows first through row 1 of stationary blades, expanding from initial pressure P to a pressure P_1 . In thus expanding it attains a velocity, the energy of which is given up on the moving blades, row 2. In the passage of steam through the blades of row 2 the shape of the blades is

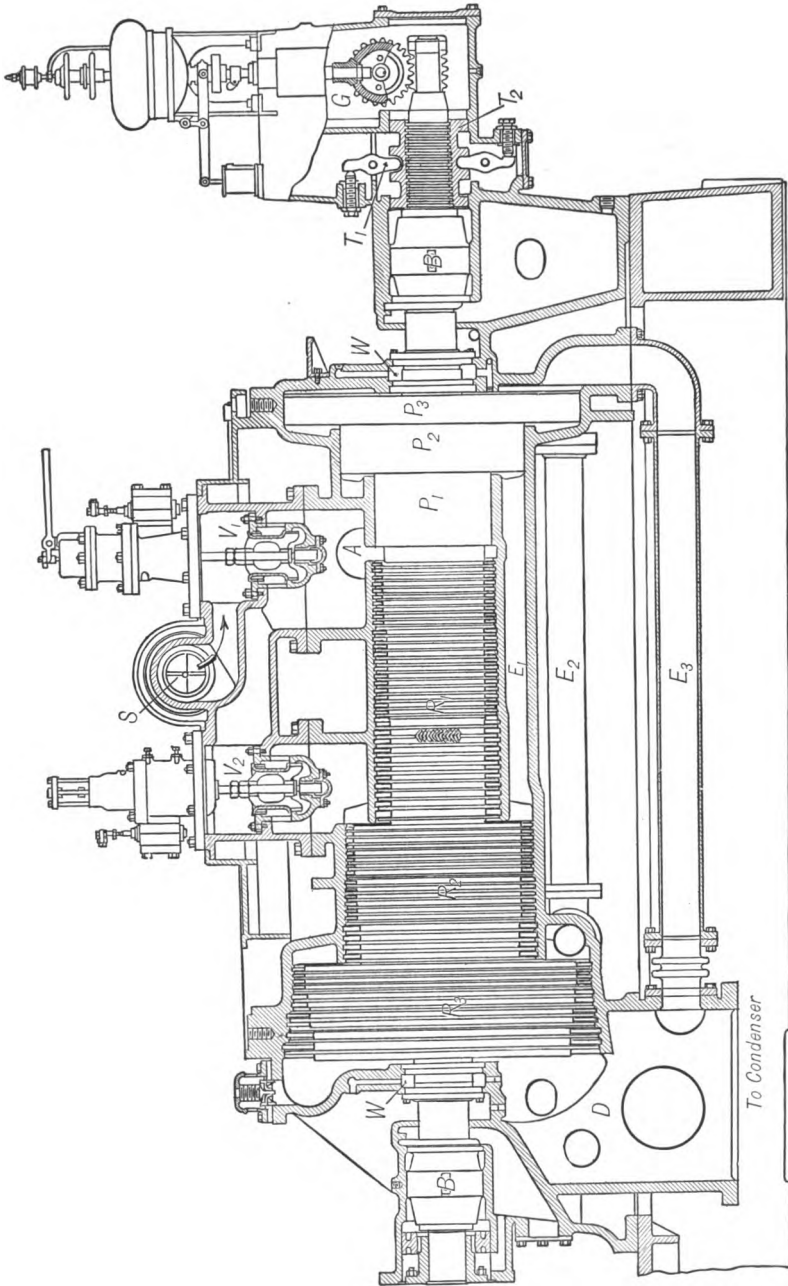

Fig. 175. Westinghouse-Parsons Turbine.

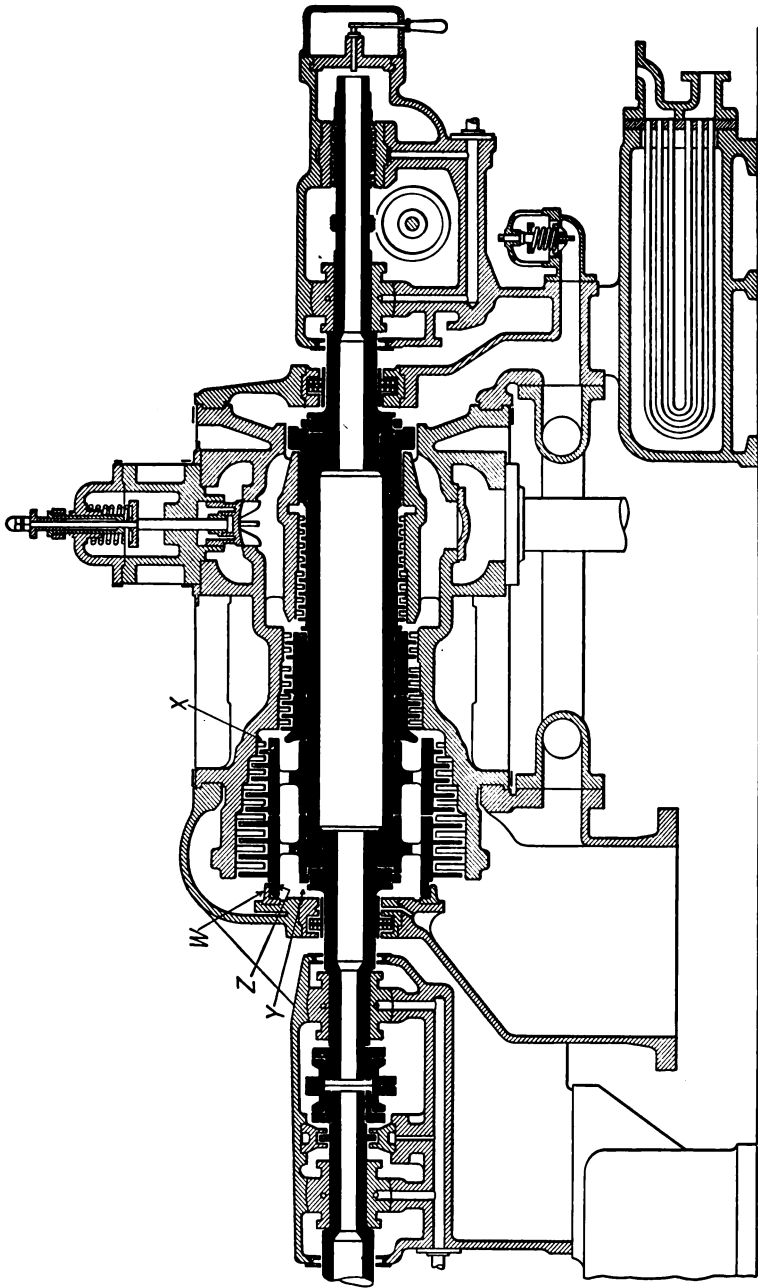

FIG. 176. Allis-Chalmers Turbine.

such that expansion again occurs, the pressure dropping from P_1 to P_2 . This expansion again produces a velocity, but this time its effect is to react on row 2 as the steam issues from it. This cycle is repeated a number of times until exhaust pressure is reached. It is evident, then, that the so-called reaction turbine makes use both of the impulse and the reaction of the steam.

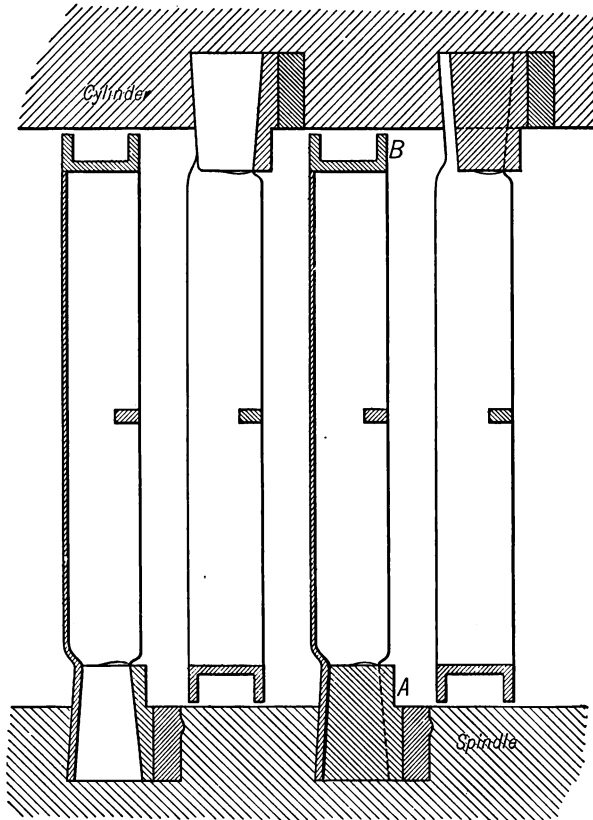

FIG. 177.

Fig. 175 is a longitudinal section of a typical Westinghouse-Parsons steam turbine. Steam enters through the strainer at S , passes through the main admission valve, and enters the turbine at A . After expanding through the cylinders R_1 , R_2 , R_3 , it passes down the exhaust chamber D to the condenser. The rotating member, or rotor, consists of the parts R_1 , R_2 , R_3 , and P_1 , P_2 , P_3 . The parts R_1 , R_2 , R_3 , consist of steel drums

mounted upon a spindle, in which are inserted the rows of buckets or blades. On the opposite end of the spindle are the balance pistons P_1, P_2, P_3 , of such diameters as to exactly balance the axial pressure on the drums R_1, R_2, R_3 , the different pressures at either end of the respective drum diameter being communicated to the corresponding piston faces by means of the passages E_1, E_2, E_3 . The rotor revolves in the stationary cylinder which has rows of guide blades corresponding to those on the rotor but set in the reverse positions (see Fig. 174). There are three large changes in the diameter of the working portions of the rotor and cylinder. These are commonly referred to as the high pressure, intermediate pressure and low pressure cylinders, respectively, starting with the small diameter R_1 . Each cylinder is divided into small steps, each one of these steps having blade rows of the same height. Each of these steps is known as a barrel, there being usually three to five barrels in each cylinder and anywhere from one to twenty rows of blades in each barrel.

Fig. 176 is a section of an Allis-Chalmers turbine of the Parsons type. This is the same in principle as the Westinghouse-Parsons but differs in detail of construction. Fig. 177 shows the buckets and guide vanes for the same machine.

113. Combination of Impulse and Reaction Turbines. Fig. 178 is a section of a "Double Flow" Westinghouse Turbine. Steam enters as shown, strikes first upon a two-velocity-stage wheel of the same type as used in the Curtis machine, then flows each way to a wheel of the regular Parsons type. All three wheels are on the same shaft. Since the steam flows in both directions on the Parsons wheels it is possible to balance the end thrust without the use of balance pistons.

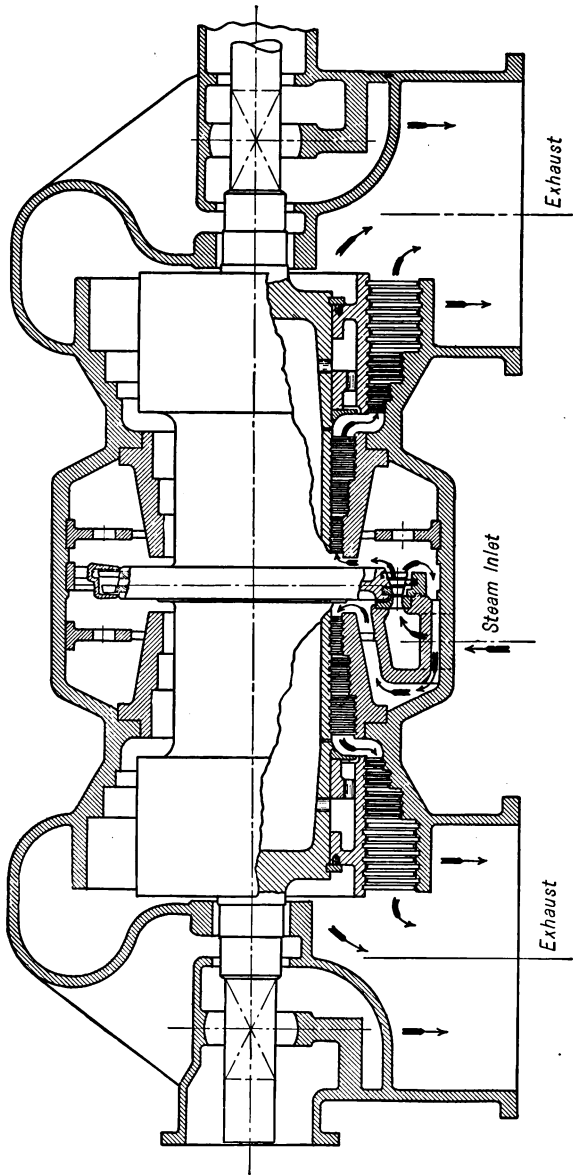

Fig. 178. Westinghouse Double-flow Turbine.

CHAPTER XI

TURBINE VALVE MECHANISMS AND GOVERNORS

114. The steam supply to a turbine, like that to a reciprocating engine, must be under the control of some mechanism which will automatically adjust the supply to the load on the turbine. There are three principal ways in which this is accomplished.

1. The steam enters the turbine through one large valve and the amount of opening through this valve is regulated by a centrifugal governor driven from the shaft. Governors of this type are, therefore, simply throttling governors.

2. The steam enters through a series of small valves and a centrifugal governor opens as many of these valves as are needed to furnish the steam supply.

3. The steam enters through a large valve which alternately opens and closes, the length of time that it is open and the amount of opening depending upon the amount of steam needed, and being regulated by a centrifugal governor.

In addition to the main governing mechanism, there is also some safety device which automatically shuts off the whole of the steam supply in case the main governor fails to exert sufficient control.

The throttling governors act much on the same principle as that described for a reciprocating engine, although the details of the mechanism are different. Two examples of the other methods of governing will serve to illustrate the general principle of turbine speed control.

115. Valve Gear on Curtis Turbine. Several different valve mechanisms and governors are used on the Curtis turbines. A description of one of these follows:

Referring to Fig. 172, steam is admitted to the steam chest, through a main throttle valve (not shown in the drawing). From the steam chest the steam is admitted to a series of ports, through which it flows to the first stage nozzles. Each of the ports is covered by a valve. If the load on the turbine is such that full capacity is required all of these valves are open, but if the load is lighter, the governor automat-

ically closes some of the valves, thus depriving part of the nozzles of steam.

The mechanism by which the valves are operated and the steam

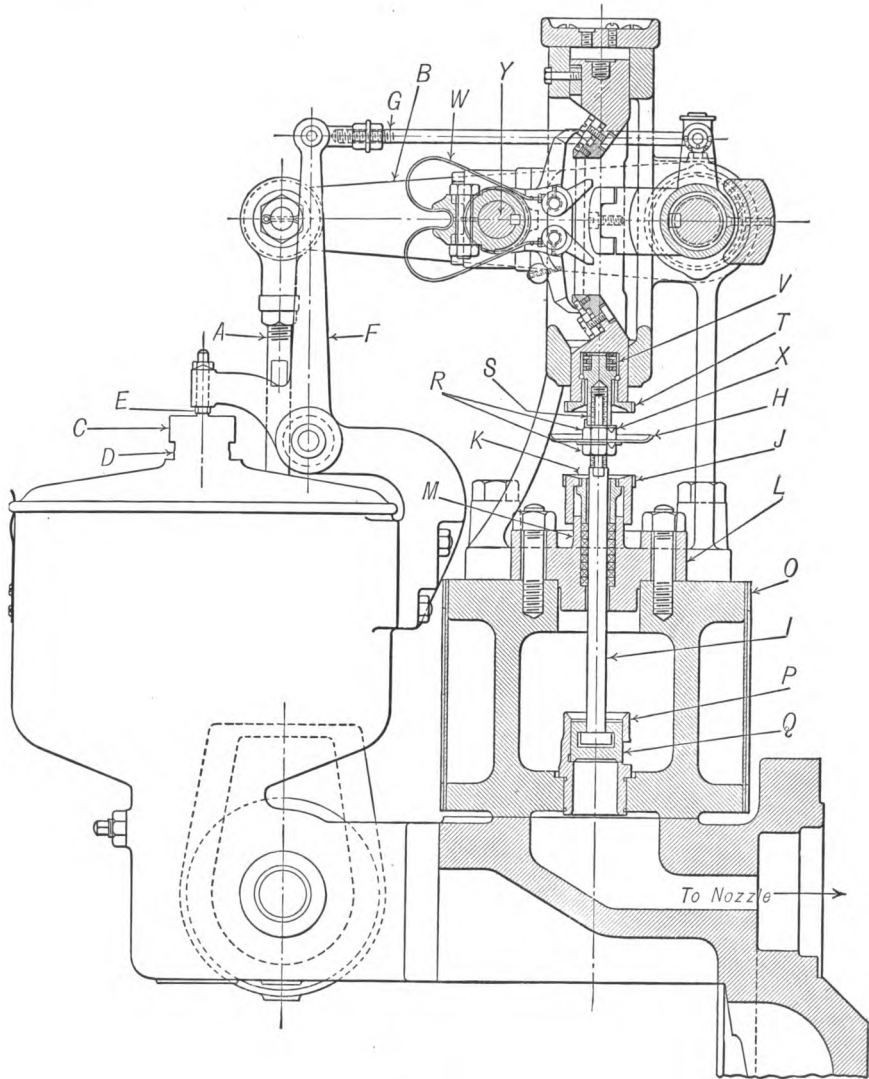

FIG. 179.

supply controlled is shown in Figs. 179 and 180. It should be noticed that the letters do not correspond in the two figures. This need not lead to confusion, however, if in reading the following discussion, care is

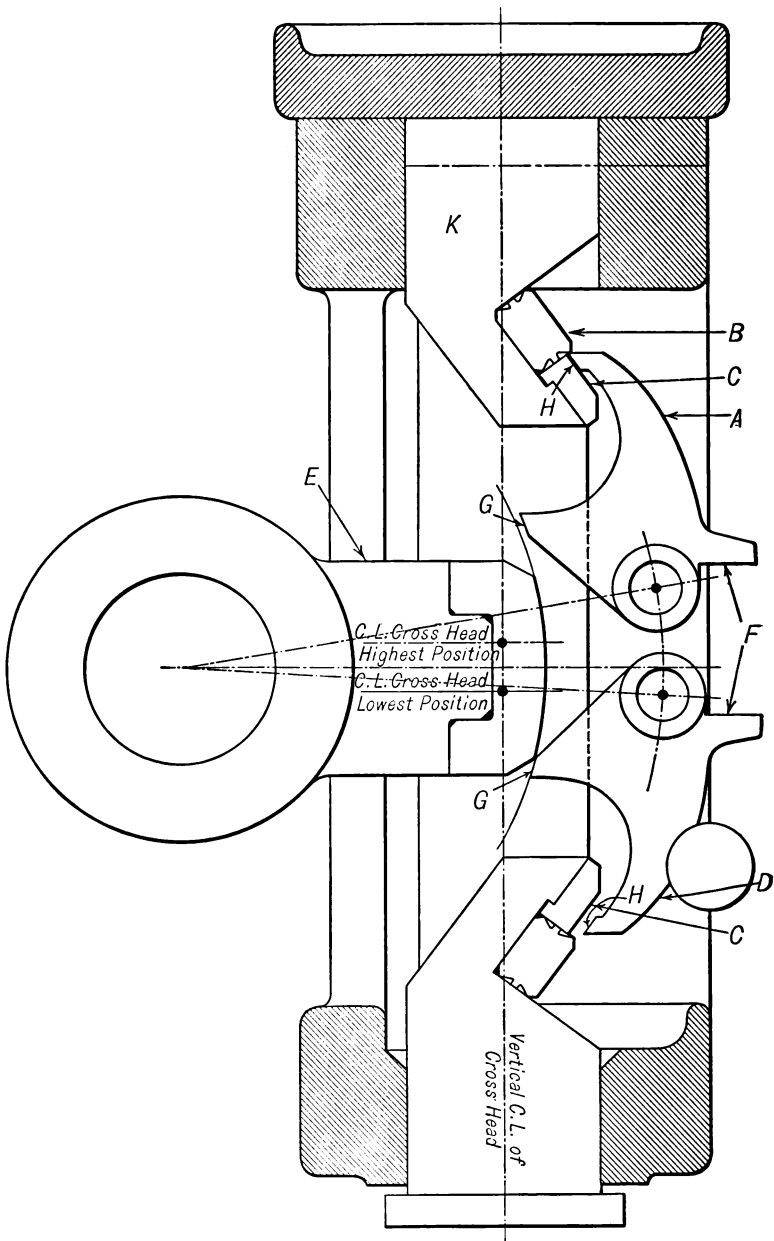

FIG. 180.

taken to observe which figure is being referred to when any letter is mentioned.

Referring to Fig. 179, the drive rod *A* is actuated by a crank on a shaft driven from the main shaft. This rocks the lever *B*. The latter carries two pawls which show plainly and which are moving up and down as *B* oscillates. Referring now to Fig. 180, the pawls are lettered *A* and *D*. *K* is a crosshead on the end of the stem of one of the valves. It is here shown in its uppermost position, and has been pushed up to that position by the pawl *A* on its upward stroke. The valve is, therefore, open and admitting steam. As the arm which carries the pawls swings down the projection *G* of the lower pawl *D* moves away from the piece *E* which has evidently swung *D* about its pivot. As soon as *G* is clear of *E* a spring (not shown in Fig. 180, but apparent in Fig. 179) swings *D* back so that its lower point *H* strikes against the piece provided for it on the lower end of the crosshead and pushes the crosshead down, closing the valve. With the "shield plate" *E* in the position shown, therefore, the valve opens at every up stroke of the lever which carries the pawls, and closes at every down stroke of the same. The position of the shield plate *E* is controlled by the governor. If the speed of the turbine increases, the governor will swing the shield plate up. The projection *G* of the opening pawl *A* will then rest on *E* and hold the pawl in such a position that the toe *H* will not catch to carry the crosshead up. That is, when the governor swings *E* up the closing pawl *D* is free to close the valve, but the opening pawl *A* cannot open it. Now, assume that with the steam shut off from the nozzles controlled by the valve, the machine slows down. The governor will move the shield plate down past the neutral position until the valve opens. If, when a valve opens, the steam admitted is still insufficient to maintain speed, the shield plates continue to move downward until the shield plate controlling the next valve to the right, which is higher in position, permits this valve to open. The same principle holds true, of course, with the machine speeding up, if when a given valve closes there is still more steam than is necessary to maintain speed with the given load. It is understood that the pawls oscillate independently of the changes of position of the shield plate and usually with much greater frequency.

Fig. 179 shows one valve element with its operating mechanism. On a complete valve gear of the 500 kw. 3600 r.p.m. machine there are six or eight complete elements (depending on steam conditions), and the successive operation of these valves is provided for by staggering the

shield plates, the one to the extreme left (facing as the steam flows into the turbine) is the lowest, each successive shield plate being about $\frac{1}{4}$ inch higher than its neighbor to the left. The left-hand valve is, therefore, the no-load valve.

It can be seen that the motion imparted by the pawl to the crosshead is transmitted through the nut T (on opening) and the compression spring V (on closing) to the adjusting nut S and thence to the valve stem I .

The governor is contained in the casing which shows at the left in Fig. 179. The rocker EF and the rod G form the linkage by means of which the governor controls the position of the shield plates. Fig. 181 contains two views of the governor. The upper view is a plan view showing the governor in its casing, with the lid cut away to show the working parts. The lower view is not a straight transverse section, but two sections. The part to the left of the center line is taken through one of the pivots, to the center; the part to the right of the center line is a section through the stud I for one of the links L , the transmission link seat V, U, Pa to the center. The spindle at the center is driven from the main shaft by a worm and wheel. As the spindle speed increases, the governor weights swing out spreading the links H and Qa , thus drawing down the left end of the rocker which adjusts the shield plates.

The spring (upper) is shown at N and one of its plugs at O , the bolt holding the plug on which the knife edge R is mounted is shown at P . These bolts can be screwed in and out of the plug for the purpose of obtaining different tension adjustments on the springs and are checked with lock nuts. The knife edge seat T is bolted to the weight B (lower figure) and the weights are caused to move in unison by two links L connecting the studs I through ball bearings M . The manner of supporting the transmission links and the details of the transmission are clearly shown and require no description except that the cage Y revolves and that the ball Ba is stationary with reference to rotation and has vertical motion only.

116. Valve Gear on Westinghouse-Parsons Turbine. Steam is admitted to the Westinghouse-Parsons turbine, Fig. 175, through the primary valve V_1 under ordinary load and also through the secondary valve V_2 in case of overload. The governor is seen at the extreme right. Fig. 182 is a section through the primary and secondary valves. When the throttle valve on the main steam pipe is open, steam fills the

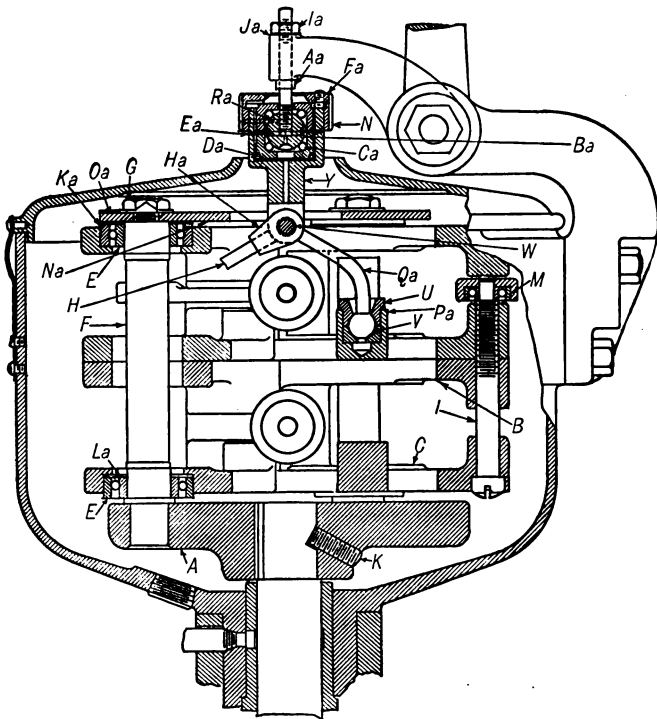
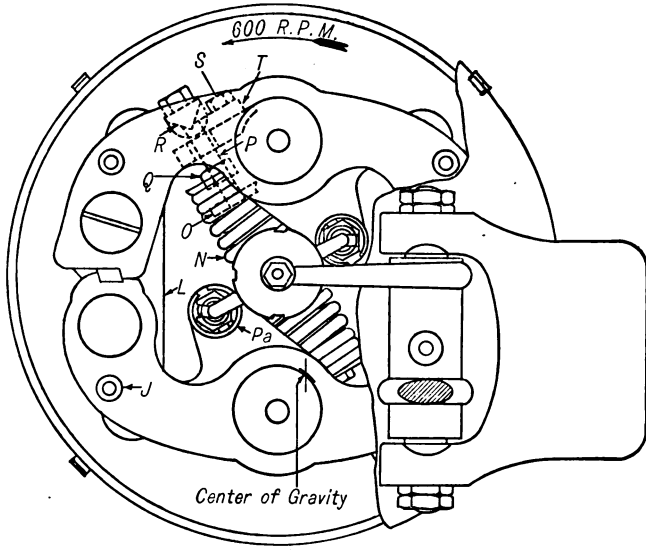

FIG. 181.

spaces V_1 and V_2 . We will first give attention to the primary valve. In order that the steam may go from V_1 into the main inlet to the turbine, the primary poppet valve must be raised from its seat. This is accomplished by steam flowing through the little passage A and forcing the piston C upward, carrying the valve stem and valve with it and thus admitting steam to the turbine. At the right is a relay plunger F which is moving up and down constantly, like the slide valve of a reciprocating engine. This relay plunger is moved from a cam or eccentric on a shaft driven from the main shaft. The connection is through a rockshaft and system of levers so arranged and so connected to the governor that the latter controls the position of the stroke of the relay valve F . When the turbine is running at normal speed and under normal load, the relay valve is in such a position that on its down stroke it opens the outlet of the passage E , allowing the steam under the piston C to exhaust through the relay steam chest. The compression spring H in the dash-pot above the piston C then forces the poppet valve shut, stopping the flow of steam to the turbine. On the up stroke of F the passage E is closed, steam pressure accumulates under C and the poppet valve again opens. The poppet valve is, therefore, traveling up and down, admitting steam to the turbine in puffs. If the load becomes lighter, the mean position of the relay plunger is lowered by the governor, allowing a greater exhaust of steam through E and allowing the spring H to close the poppet valve correspondingly. With a heavier load, the mean position of the relay plunger is raised, giving less exhaust through E and a correspondingly greater and longer opening of the poppet valve. With light loads no more pressure accumulates beneath the piston C than is sufficient to just raise the valve from its seat at each down stroke of the plunger. As the load increases, the valve has an increasing lift until at maximum load the puffs of steam merge into a continuous blast, and the valve remains practically stationary in its wide-open position. In case of overload, when the primary valve is not able to supply sufficient steam, the secondary valve opens, admitting steam directly to the second cylinder. The general mechanism of the secondary valve is similar to that of the primary valve, and its relay valve is operated by levers on the same rockshaft that operates the primary valve. The secondary valve is likely to be inoperative for long periods at a time, however, since it only operates in case of heavy load. For this reason, the relay plunger is so constructed that it does not begin to exhaust steam until the action of the secondary valve is needed. Steam is admitted to both sides of

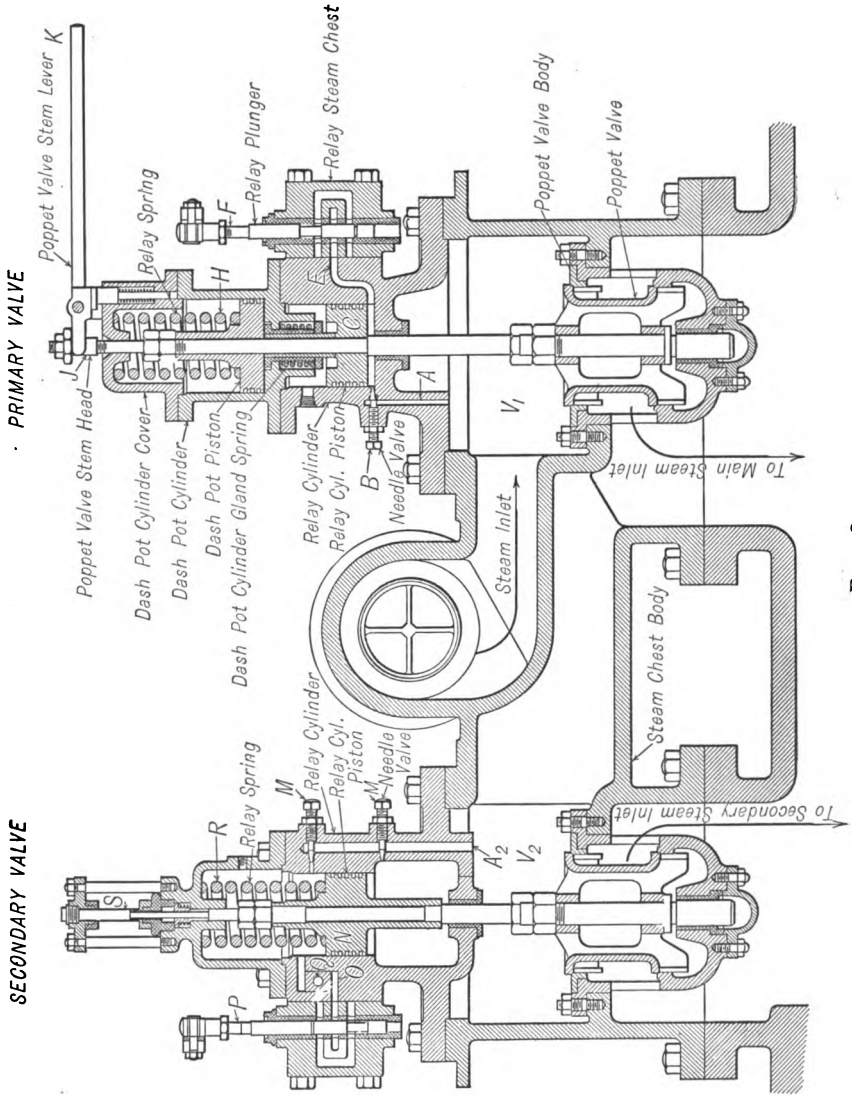

FIG. 18a.

the piston N through the passage A_2 and when, on account of increased load, the mean position of the relay plunger P is raised sufficiently by the governor, the port O is opened, exhausting the steam from the upper side of the piston N , and the valve is raised by the pressure beneath N .

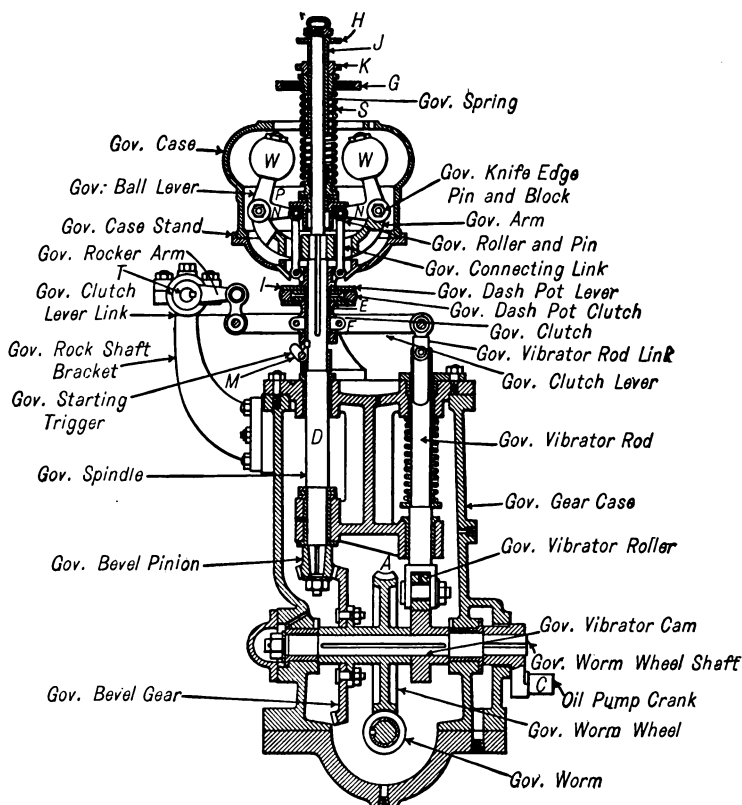

FIG. 183.

The port O may be permanently closed by the hand valve Q , thus cutting the secondary valve entirely out of action.

Fig. 183 shows the governor mechanism as far as the shaft T which carries the motion to the relay plungers through suitable levers and links. The governor clutch lever F has its fulcrum on a collar or "governor clutch" which can slide on the governor spindle. F is rocked about its fulcrum by the governor vibrator cam, rod, and link, and the other end of F rocks the shaft T by means of the governor rocker arm and the short

link. The governor spindle D is driven from the main shaft of the rotor by the governor worm, worm wheel A and a pair of bevel gears. As the speed increases, the weights W swing out, and raise the collar which forms the fulcrum of F . The arrangement of the levers between T and the relay plunger is such that as the fulcrum of F is raised the relay plunger is lowered. Since F rocks approximately the same amount about its fulcrum for all positions of the governor, the shifting of the fulcrum of F merely changes the mean position of the relay plunger without materially changing the length of its stroke. This change of mean position varies the steam supply as already explained.



INDEX

	PAGE
Action of reciprocating engines.....	2
Admission.....	3
Allan link.....	119
Allen locomotive valve.....	36
Allis-Chalmers turbine.....	150
Allis releasing gear.....	98
American-Ball engine, valve for.....	34
governor for.....	76
Angle between crank and eccentric.....	27, 38
Angle-compound engine.....	17
Angular advance.....	27
Auxiliary valve circle (see Relative displacement circle).....	84
Balanced valves.....	31 to 34
Ball engine (see American-Ball engine).....	34, 76
Bell-crank lever.....	12
Bilgram diagram.....	45
Bridges.....	2
Buckeye engine, valve for.....	90
Bushing for piston valve.....	32
Calculations for size of ports.....	58
Carrier.....	12
Classification of reciprocating engines (see Types of engines).....	16
Classification of turbines (see Types of turbines).....	139
Clearance — exhaust.....	25
Clearance — riding valve.....	81
Combined reaction and impulse turbines.....	154
Combined velocity-stage and pressure-stage turbines (see Curtis turbine).....	149
Compound engines.....	17
Compression.....	3
Condensing engines.....	22
Connecting rod and crank.....	4
Constant-absolute-travel riding valve.....	85
Constant-clearance riding valve.....	85
Constant relative-travel riding valve.....	90
Corliss valve mechanism.....	95
Crank positions for different events of stroke.....	4, 27 to 30
Crank positions — notation for.....	3
Crosby indicator.....	13, 14
Cross-compound engine.....	17

	Page
Crosshead displacement	4
Crosshead velocity	6
Curtis turbine	149
Curtis turbine valve gear	156 to 161
Cut-off	3
Cut-off valve in separate chest	78
Dash-pot	100
D valve	25, 28
Dead points	2, 126
De Laval turbines	140 to 147
Diagrams,	
indicator	12
for single slide valves	39 to 47
for riding valves	82 to 94
Displacement,	
of crosshead	4
of valve	10
Double-flow turbines	154
Double-ported Corliss valve	100
Double-ported slide valve (see Ported valves)	35
Double piston valve	90
Double valves (see also Riding cut-off valves)	78
Eccentric rod and eccentric	9
Eccentricity	9
Ellipse — valve	39
Equal events	30
Events of the stroke	3
Events of stroke — position of mechanism for	27 to 30
Expansion of steam	3, 139
Flywheel governors	65 to 77, 86, 107
Fitchburg four-valve engine gear	105
Fitchburg valve	106
Fitchburg governor	107
Four-valve engines (see Multiple-valve engines)	95 to 110
Gooch link	118
Governors for reciprocating engines	63 to 77, 86, 107
Governors for steam turbines	156 to 165
Gridiron valves	108
Hackworth valve gear	124
Hamilton-Corliss engine (see Hooven, Owens, Rentschler)	7
Hand-operated reversing and controlling gears	111 to 127
Harmonic motion	7
Hooven, Owens, Rentschler releasing gear	97
Horizontal engine	17
Impulse turbines	139 to 150
Indicated horse power	16
Indicator cards (in Indicator diagrams)	12, 15, 136, 137
Indicator diagrams (see Indicator cards)	12, 15, 136, 137
Indicator — steam engine	13, 14

	PAGE
Inertia governors	75
Joy valve gear	127
Laps	25
Layout of D valve	58
Layout of double valve	90
Layout of Meyer valve	94
Lead	25
Lead angle	25
Link mechanisms	111 to 119
McIntosh & Seymour valve gear	108
Marshall valve gear	126
Mean effective pressure	16
Meyer valve	93
Mid-position	10
Modifications of slide valve	31
Multiple-expansion engines	17
Multiple-valve engines	95 to 110
Non-condensing engines	22
Notation for crank positions	3
Parsons turbine	150 to 155
Piston valve	31, 90
Plain slide valve	25
Poppet valve	110
Ports	2
Port calculations	58
Ported valves	35
Pressure-compounding turbines (see Pressure-stage turbines)	145
Pressure-stage turbines	145
Problems on slide-valve engine	48 to 62
Radial valve gears	119 to 127
Reaction turbines	139, 150 to 155
Reciprocating engine, definition of	viii
description of	1
Relative displacement	84
Relative-displacement circle	84
Release	3
Reuleaux diagram	44
Rice & Sargent valve gear	102
Ridgway engine, governor for	76
valve for	37
Riding cut-off valve	81 to 94
Rockers	10 to 12, 73, 117
Rotary slide valve	126
Setting valves	129 to 133
Short cut-off	57
Simple engine	1, 17
Single-stage turbines	140

	PAGE
Skinner balanced valve.....	33
Steam — expansion of.....	3, 139
Stephenson link.....	113 to 118
Sulzer valve gear.....	109, 110
Tandem compound engine.....	7
Throttling governor.....	65
Tram.....	130
Travel of valve.....	9
Triple-expansion engines.....	22
Turbine speed control — methods of.....	156
Turbines — steam.....	138 to 155
Turbines — governors and valve gears for.....	156 to 165
Types of engines.....	16
Types of turbines.....	139
Valve displacements.....	10
Valve ellipse.....	39
Valve setting.....	129 to 133
Velocity of crosshead.....	6
Velocity-compounding turbines (see Velocity-stage turbines).....	144
Velocity-stage turbines.....	144
Vertical engines.....	17
Walschaert valve gear.....	119 to 125
Westinghouse-Parsons turbine.....	150 to 154
Westinghouse-Parsons turbine valve gear.....	162 to 165
Zeuner's diagram.....	41 to 44

MAY 2 1918

