

MAXWELL'S THEORY
AND
WIRELESS TELEGRAPHY

PART ONE

MAXWELL'S THEORY AND HERTZIAN
OSCILLATIONS

By H. POINCARÉ

TRANSLATED

By FREDERICK K. VREELAND

PART TWO

THE PRINCIPLES OF WIRELESS TELEGRAPHY

By FREDERICK K. VREELAND

NEW YORK:
MCGRAW PUBLISHING COMPANY,
114 LIBERTY STREET.
1904.

**COPYRIGHT, 1904,
BY THE
MCGRAW PUBLISHING COMPANY,
NEW YORK.**

SEC.	PAGE.
3. Different Forms of Oscillators	33
4. Function of the Spark	35
5. Influence of Light	36
6. The Use of Oil	37
7. Value of the Wave-length	37

CHAPTER V.

METHODS OF OBSERVATION.

1. Principle of the Resonator	38
2. Operation of the Resonator	39
3. Other Methods of Using the Spark	42
4. Thermal Methods	43
5. Mechanical Methods	44
6. Comparison of the Different Methods	45
7. Coherers	45

CHAPTER VI.

PROPAGATION ALONG A WIRE.

1. Production of Waves in a Wire	48
2. Mode of Propagation	49
3. Velocity of Propagation and Diffusion	50
4. Experiments of MM. Fizeau and Gounelle	52
5. Diffusion of Currents	54
6. Experiments of M. Blondlot	55

CHAPTER VII.

MEASUREMENT OF WAVE-LENGTH AND MULTIPLE RESONANCE.

1. Stationary Waves	59
2. Multiple Resonance	61
3. Another Explanation	62
4. Experiments of Garbasso and Zehnder	65
5. Measurement of the Decrement	66
6. Experiments of Strindberg	68
7. Experiments of Pérot and Jones	69
8. Experiments of Décombe	69

CHAPTER VIII.

PROPAGATION IN AIR.

1. The Experimentum Crucis	71
2. Experiments at Karlsruhe	73

CONTENTS.

v

SEC.	PAGE.
3. Experiments at Geneva	74
4. Use of the Small Oscillator	74
5. Nature of the Radiations	76

CHAPTER IX.

PROPAGATION IN DIELECTRICS.

1. Maxwell's Relation	79
2. Dynamic Methods	80
3. Static Methods	80
4. Results	81
5. Conducting Bodies	82
6. Electrolytes	83

CHAPTER X.

PRODUCTION OF VERY RAPID OSCILLATIONS.

1. Very Short Waves	85
2. Righi's Oscillator	85
3. Resonators	87
4. Bose's Oscillator	88
5. Bose's Detector	89

CHAPTER XI.

IMITATION OF OPTICAL PHENOMENA.

1. Conditions of Imitation	91
2. Interference	92
3. Thin Films	94
4. Secondary Waves	94
5. Diffraction	96
6. Polarization	97
7. Polarization by Reflection	98
8. Refraction	98
9. Total Reflection	99
10. Double Refraction	100

CHAPTER XII.

SYNTHESIS OF LIGHT.

1. Synthesis of Light	101
2. Other Differences	102
3. Explanation of Secondary Waves	103
4. Miscellaneous Remarks	106

PART TWO.**THE PRINCIPLES OF WIRELESS TELEGRAPHY.****CHAPTER I.****GENERAL PRINCIPLES.**

SEC.	PAGE.
1. Methods of Signaling Through Space	111
2. Method of Electromagnetic Induction	113
3. Preece's Apparatus	115
4. Method of Electrostatic Induction	117
5. Dolbear's and Edison's Apparatus	119
6. Method of Electromagnetic Waves	121
7. Comparison of the Three Methods	126

CHAPTER II.**TELEGRAPHY BY HERTZIAN WAVES.**

1. Early Experiments	130
2. Marconi's Early Apparatus	132
3. Improved Apparatus	135
4. The Antenna	138

CHAPTER III.**THE GROUNDED OSCILLATOR.**

1. Development of Antenna	141
2. Other Means of Increasing the Radiation	146
3. The Induction Coil	149
4. High-Power Generators	151

CHAPTER IV.**PROPAGATION OF GROUNDED WAVES.**

1. Three Hypotheses Suggested	156
2. The Free-Wave Hypothesis	157
3. The Alternating-Current Hypothesis	159

CONTENTS.

vii

SEC.	PAGE.
4. Propagation Free Waves	163
5. Propagation of Guided Waves	172
6. Effect of Daylight on Wave Transmission	176

CHAPTER V.

THE RECEIVING APPARATUS.

1. Detectors Classified	179
2. Microphonic Detectors	179
3. Mechanical Detectors	185
4. Thermal Detectors	186
5. Electrolytic Detectors	187
6. Magnetic Detectors	191
7. Arrangement of Receiving Apparatus	194
8. Current Multiplying Devices	199

CHAPTER VI.

SELECTIVE SIGNALING.

1. The Problem	202
2. Directed Signals	203
3. Syntonic Signaling	204
4. Lodge's Syntonic Cones and Leyden Jars	208
5. Marconi's Concentric Cylinders	211
6. The Closed Oscillating Circuit	212
7. Inductively Interlinked Circuits	215
8. Tuned Receiving Apparatus	223
9. Marconi's Coherer System	226
10. Slaby-Arco System	228
11. Braun's System	234
12. Lodge-Muirhead System	235
13. Limitations of Syntonic Signaling	237
14. Other Means of Securing Selectivity	242
15. Conclusion	245

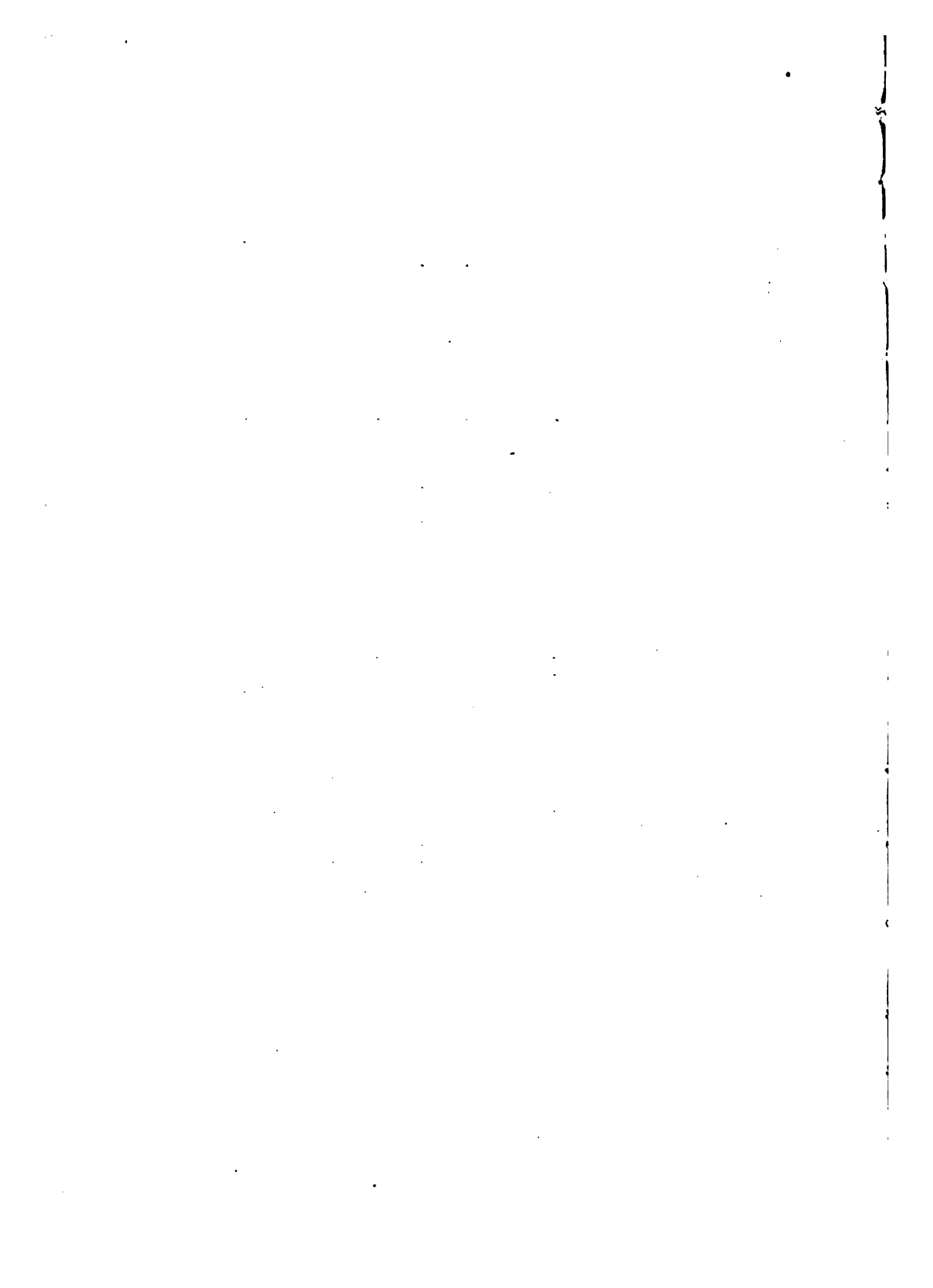

PREFACE.

The object of this book is to give a physical treatment of Maxwell's theory and its applications to some modern electrical problems,—to set forth the fundamental principles which underlie all electrical phenomena, according to Maxwell and his followers, to show how these principles explain the ordinary facts of electricity and optics, and to derive from them a practical understanding of the essentials of wireless telegraphy.

Mathematics and abstruse reasoning are avoided, for the purpose is not to establish or defend a theory, but rather to give the reader a clear mental picture of what takes place when, for example, a condenser is charged or a signal is sent around the earth — not to fight over old battles, but to pick out the fundamentals that have stood the test and are now generally accepted, and put them in such form that the busy man may use them or the student may take them as stepping-stones to the more advanced theory.

Maxwell's theory without mathematics may seem at first an incongruity, for has not Hertz himself said that Maxwell's theory is best defined as Maxwell's system of equations? * Maxwell indeed used many hypotheses and physical assumptions in building up his theory, but later, when the mathematical structure was complete, he cast aside the scaffolding on which it was built, leaving a broad and comprehensive system, unencumbered by needless details. His

* *Electric Waves*, Eng. Trans. p. 21.

equations are thus general rather than specific; they express all that is necessary and permanent in his theory, while ignoring that which is hypothetical and speculative.

A purely physical theory is likely to be imperfect by reason of its very definiteness; to be incomplete because it is too specific. Yet a mathematical theory without a physical interpretation loses much of its value. Maxwell's equations are not an end in themselves — they are rather the means of expressing physical truths. The equation represents the fact, but unless we recognize and grasp the fact the analysis becomes mere mathematical jugglery: and this is perhaps one reason why Maxwell's great generalizations — the very "Principia" of modern electrical science — have not received more general attention. They are difficult to approach in the abstract, but so are the commonest electrical phenomena. It is not easy to conceive, in its essence, of an electrical current following a wire; we therefore picture it to ourselves as something that flows like a material fluid in a pipe, and we find that it obeys similar laws. When we come to the more complex phenomena of induction and magnetism the need of a physical concept is even greater, and we turn for assistance to the traditional lines or tubes of force and induction. These physical conventions lack the precision and elegance of a mathematical expression, but they are more easily grasped and handled: if we realize their limitations and take pains to discriminate between that which is absolute fact and that which is only figurative, they become most useful implements of research, and we may take them, as Faraday did his "tubes of force," as the equivalents of the mathematical forms for which they stand.

So in dealing with Maxwell's theory it is not necessary to resort to mathematics. Although electrical truths are most readily and most accurately expressed in this universal

shorthand of the sciences, it is none the less possible to translate them, as it were, into the language of every-day life, and thus cause them to appeal more directly to the understanding.

That M. Poincaré is, of all men, qualified to do this, no one familiar with his classic mathematical works on the subject will question; and with reference to Part One I need only say that I have endeavored to follow the original with as literal exactness as is practicable in a translation, striving to preserve the thought of the author without sacrificing the vigorous suggestiveness of his style. The illustrations, however, I have prepared especially for this volume, with the exception of a few diagrams which appeared in the original, and which have been redrawn.

In Part Two it has been my purpose to take up the thread where M. Poincaré dropped it, carrying the line of thought into the practical field of wireless telegraphy, and applying the principles laid down in Part One to the various problems involved; to describe certain typical systems, to show why some have failed while others succeeded, and to explain their mode of operation in the light of Maxwell's ideas.

This is not intended as a treatise on wireless telegraphy — no attempt is made to describe the myriad forms of apparatus nor to settle questions of priority and history. Such material is readily accessible to those who may desire it. The object is rather to deal with principles and to trace the development of the art in its essential features. Where specific cases are cited they are chosen with reference to their fitness to illustrate an idea or to serve as milestones on the path of progress, and they are treated with a view to emphasize that which is essential and minimize superficial or unimportant details.

In Chapter IV is discussed the question of wave-propagation over a conducting surface, and various hypotheses are reviewed and tested in the light of the preceding chapters. In approaching a conclusion it has seemed advisable to depart a little from the purely Maxwellian idea of displacement currents, which does not readily appeal to the imagination in this connection, and to substitute Faraday's conception of moving tubes of induction, which embodies the same principles in more tangible form. It is hoped that this figure, so successfully used by J. J. Thomson in explaining other electrical phenomena, may give the reader a clear understanding of what takes place when an electromagnetic wave glides over the surface of the earth.

The other chapters are self-explanatory and need not be considered here.

I desire to acknowledge my indebtedness to M. Poincaré for his most courteous permission to translate and publish the work that appears as Part One, and to the many writers on whom I have drawn for references and historical data. My thanks are due also to the Macmillan Company for permission to copy some of the figures illustrating the work of Hertz, and to the publishers for their hearty coöperation in seeing the work through the press.

FREDERICK K. VREELAND.

NEW YORK, *January*, 1904.

PART ONE.

**MAXWELL'S THEORY AND HERTZIAN OSCILLA-
TIONS.**

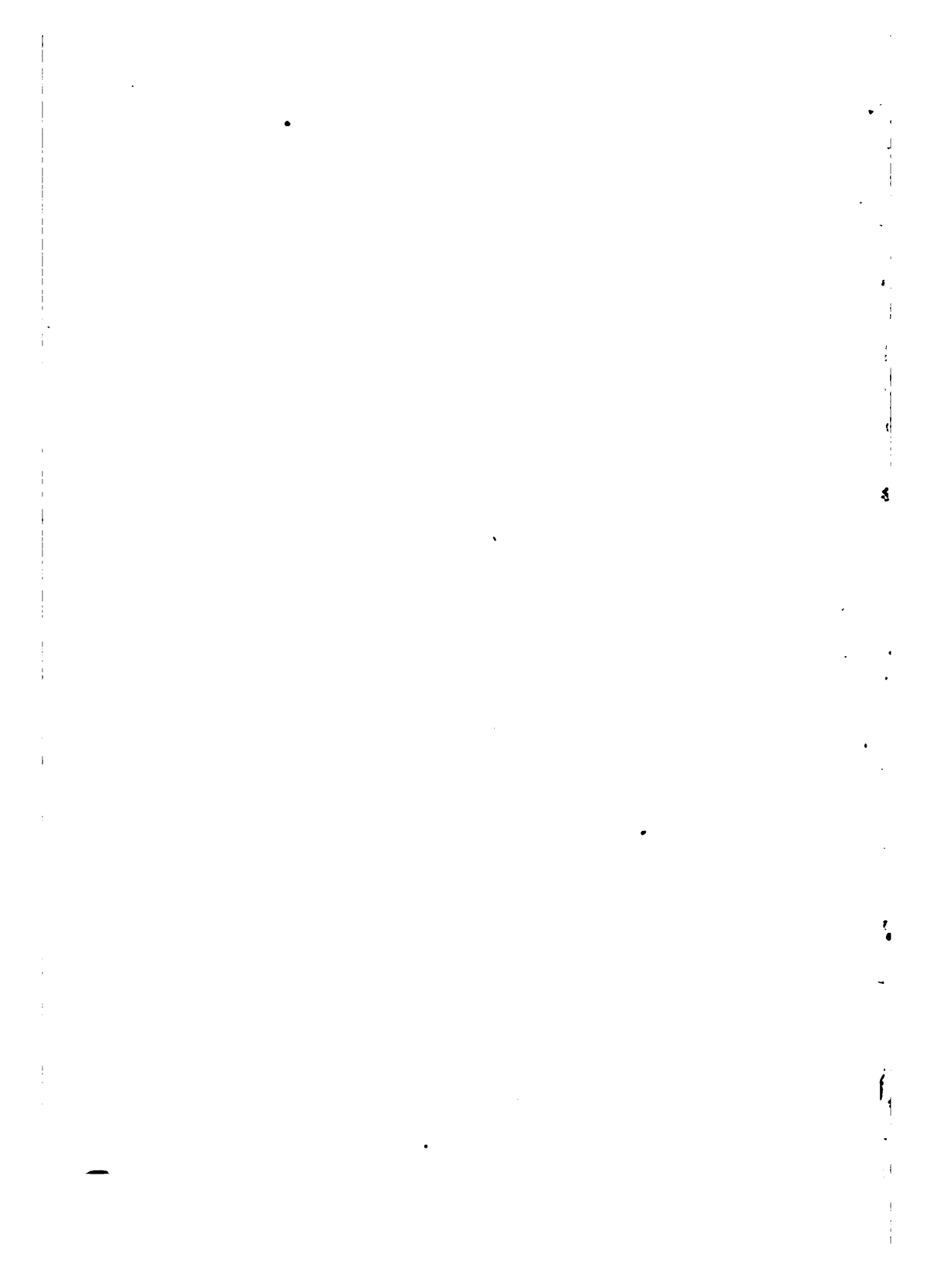

PART ONE.

MAXWELL'S THEORY AND HERTZIAN OSCILLATIONS.

CHAPTER I.

GENERALIZATIONS REGARDING ELECTRICAL PHENOMENA.

1. **Attempts at Mechanical Explanation.**—To give a complete mechanical explanation of electrical phenomena, reducing the laws of physics to the fundamental principles of dynamics, is a problem that has attracted many investigators. But is it not rather a fruitless task, and will not our efforts be expended in vain?

If the problem admitted of only one solution, the possession of this solution, which would be the truth, could not be bought too dearly. But this is not the case. It is doubtless possible to devise a mechanism giving a more or less perfect imitation of electrostatic and electrodynamic phenomena; but if we can imagine one such mechanism, we can also imagine an infinity of others. Among them all, we do not at present find one that appeals to our choice on the score of simplicity, nor is it evident that any one would enable us, better than the others, to penetrate the secret of nature. All those that have been proposed have a savor of artificiality which is repugnant to the reason.

One of the most complete of these was developed by Maxwell, at a time when his ideas had not yet taken definite form. The complicated structure which he attributed to the ether rendered his system strange and unattractive; one seemed to be reading the description of a workshop with gearing, with rods transmitting motion and bending under the effort, with wheels, belts and governors.

Whatever may be the taste of the English for conceptions of this kind, whose concrete appearance appeals to them, Maxwell was the first to abandon his own extraordinary theory, and it does not appear in his complete works. But we cannot regret that his mind followed this by-path, since it was thus led to the most important discoveries.

In following the same course, it seems hardly possible to obtain a better result. But if it is vain to attempt to picture the mechanism of electrical phenomena in all its details, it is nevertheless important to show that these phenomena obey the general laws of mechanics.

These laws, in fact, are independent of the particular mechanism to which they apply: they must remain invariable throughout the diversity of their manifestations. If the electrical phenomena are exceptions, we must abandon all hope of a mechanical explanation; but if they conform to these laws, the possibility of such explanation is assured, and we are confronted only by the difficulty of choosing among the various solutions which the problem admits.

But how can we assure ourselves, without following all the complications of mathematical analysis, of the conformity of the laws of electrostatics and electrodynamics to the general principles of dynamics? By a series of comparisons. When we wish to analyze an electrical phenomenon, we shall take one or two well-known mechanical phenomena and endeavor to show their perfect parallelism. This parallelism will thus

be a sufficient proof of the possibility of a mechanical explanation.

The use of mathematical analysis would serve only to show that these analogies are not merely rough approximations, but may be followed into the most minute details. The limits of this work will not permit us to go thus far, and we must be content with a comparison, as it were, qualitative.

2. Electrostatic Phenomena.—In charging a condenser energy is always expended; mechanical work if we turn a static machine or a dynamo, chemical energy if we charge it with a battery. But the energy thus expended is not lost;

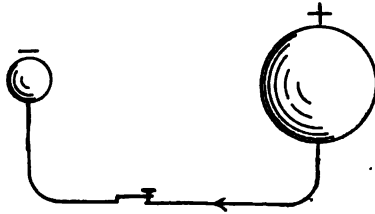

FIG. 1.—Two conductors are charged to different potentials and then connected by a wire. A current flows from one to the other until the potentials are equalized.

it is stored in the condenser, to be liberated again when the condenser is discharged. It will be liberated in the form of heat if the two plates of the condenser are simply joined by a wire, which is heated by the discharge current; or it may be made to take the form of mechanical work by causing the discharge current to operate a little electric motor.

Similarly, to raise the level of water in a reservoir, work must be done; but this work may be given back, if, for example, the water in the reservoir be used to turn a water-wheel.

If two conductors be charged to the same potential, and then connected by a wire, the equilibrium will not be dis-

turbed; but if the initial potentials be different, a current will flow through the wire from one conductor to the other until the equality of potential is established. (Fig. 1.)

Similarly, if the water in two reservoirs stand at different levels and the reservoirs be joined by a pipe, water will flow from one to the other until it stands at the same level in both. (Fig. 2.)

The parallelism is thus complete: the *potential* of a condenser corresponds to the height of the water in a reservoir, the *charge* of the condenser to the mass of the water contained in the reservoir.

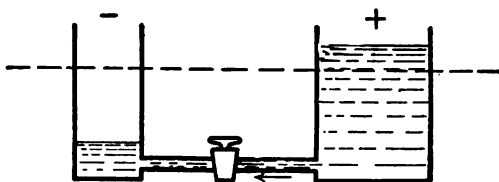

FIG. 2.—Hydraulic analogue of the charged conductors. The height of water represents the potential; the mass of the water, the charge on the conductor; the cross-section of the reservoir, the capacity of the conductor.

For example, if the horizontal section of the reservoir be 100 square meters, one cubic meter of water will be required to raise the level one centimeter. If the section be twice as great, double the quantity of water will be required. The horizontal section thus corresponds to what is called the *capacity* of the condenser.

How can we interpret in this manner the attractions and repulsions which are exerted between electrified bodies?

These mechanical forces tend to diminish the difference of potential between the bodies. If they be opposed, as when two mutually attracting bodies are separated, work is done, electrical energy is stored up, and the difference of potential

is increased. If, on the other hand, the conductors be left free to obey their mutual attractions, the stored-up electrical energy is partly given up in the form of mechanical work, and the potentials tend to be equalized.

These mechanical forces thus correspond to the pressures exerted on the walls of the reservoirs by the water which they contain. Suppose, for example, that our two reservoirs be joined by a horizontal cylindrical pipe of large cross-section, in which is fitted a piston. (Fig. 3.) When the piston is moved in such a direction as to force water into the reservoir where the level is already higher than in the other, work is expended; if, on the other hand, the piston be left free to

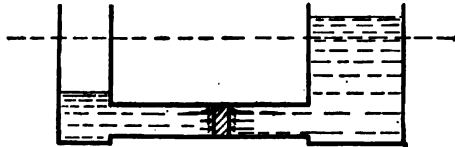

FIG. 3.— The mechanical force between two oppositely charged bodies tends to diminish their difference of potential. If this force be opposed, as when the piston is forced against the pressure, work is done, energy is stored, the difference of potential is increased.

yield to the pressures on its opposite faces, it will be displaced in such a way that the water-levels tend to be equalized, and part of the energy stored in the reservoirs will be released.

This hydraulic analogy is the most convenient and most complete; but it is not the only one possible. For instance, we might compare the work done in charging a condenser to that required to raise a weight or compress a spring. The energy thus expended is given back when the weight is allowed to descend, or the spring is released, just as when the two plates of a condenser are allowed to obey their mutual attractions.

In the following pages we shall make use of all three analogies.

3. Resistance of Conductors.— Suppose our two reservoirs to be joined together by a long, horizontal tube of small cross-section. (Fig. 4.) The water will run slowly through this tube, and the flow will increase as we increase the difference of level in the reservoirs and the cross-section of the tube, or as we diminish its length. In other words, the resistance of the tube, being due to internal friction, increases with its length and with a diminution of its area.

Similarly, if we connect two conductors by a long, slender wire, the flow of electricity will increase with the difference

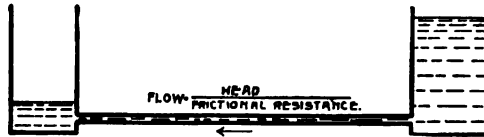

FIG. 4.— Ohmic resistance is analogous to friction of water flowing through a slender tube. The flow depends upon the difference in level, the bore of the tube and (inversely) on its length. The energy lost goes into heat.

of potential and with the cross-section of the wire, and will vary inversely as its length.

The electrical resistance of a wire is therefore comparable to the hydraulic resistance of our tube: it is a kind of friction. The similarity is the more complete, for the resistance causes the wire to become heated as in the case of mechanical friction.

This effect is strikingly shown in the well-known experiment of Foucault. When a disc of copper is caused to rotate in a magnetic field, a considerable force is required to turn it, and the disc becomes heated, precisely as if the disc were rubbing against an invisible brake.

4. Induction.— If two wires be placed close together, and one of them carry a variable current, currents will also be produced in the second. If the primary current be increasing, the secondary current will be in the opposite direction to the primary: if the primary be decreasing, the secondary will be in the same direction. The currents in the secondary circuit are known as induced currents, and the phenomenon is called *mutual induction*.

But this is not all. A variable current produces electromotive forces of induction in the wire traversed by the current itself. This force is opposing if the current be increasing, but it tends to augment the current when the latter is decreasing. This effect is called *self-induction*.

In our mechanical analogy, self-induction is easily explained. It seems that, to set electricity in motion, we must overcome a counter-electromotive reaction; but once the motion is commenced, it tends to continue of itself. *Self-induction is thus a sort of inertia*.

Similarly, a reaction must be overcome in starting a vehicle in motion; but, once it is started, the motion tends to continue of itself.

To recapitulate, a current may have to overcome:

First. The ohmic resistance of the circuit (which always exists and always opposes the current).

Second. Self-induction, if the current is variable.

Third. Counter-electromotive forces of electrostatic origin, if there are electrical charges in the neighborhood of the circuit or upon it.

The last two reactions may become negative and tend to augment the current.

Compare these reactions with those encountered by a vehicle moving along a road:

First. Ohmic resistance, we have seen, is analogous to friction.

Second. Self-induction corresponds to the inertia of the vehicle.

Third. The forces of electrostatic origin are like the weight, which opposes the motion when ascending a grade, and assists when descending.

For mutual induction the matter is a little more complicated. Imagine a sphere, S , of considerable mass, which carries two arms at diametrically opposite points; and at the ends of these arms, two small spheres, s_1 and s_2 . (Fig. 5.)

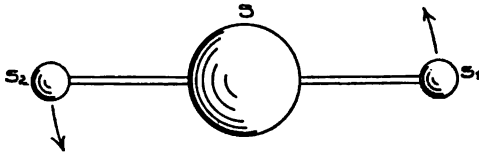

FIG. 5.—Mechanical model illustrating the phenomena of mutual induction. The small spheres, s_1 and s_2 , represent two mutually inductive circuits; the sphere, S , of large mass, the ether which surrounds them. Any variation in the velocity of s_1 (primary current), induces a velocity in s_2 (secondary current), on account of the inertia of S .

S represents the ether, s_1 the primary current, and s_2 the secondary current.

If we wish to set the little sphere s_1 in motion it offers little opposition; but the sphere S does not start so readily. For the first instant it remains motionless and the whole system turns about it as a center, the sphere s_2 moving in the opposite direction to s_1 .

This represents the action of mutual induction. The spheres s_1 and s_2 correspond to the two conductors; the sphere S , which we must imagine invisible, is the ether which surrounds them. When the motion of s_1 is accelerated, s_2 moves in the opposite direction; similarly, when the primary

current increases, a secondary current is induced in the opposite direction.

Pursuing the analogy, suppose the motion of s_1 and s_2 to be retarded by a sort of friction (the ohmic resistance of the two conductors), while S has no resistance to overcome but its own inertia; and suppose the motive force to act continuously on s_1 . When a condition of uniform motion is finally established, the sphere s_1 will move at a constant velocity, carrying with it S , which, once in motion, offers no further resistance. The sphere s_2 , by virtue of its friction, will remain motionless, and the whole system will revolve about it. The primary current has become constant; the secondary current has ceased.

Finally, if the motive force cease to act on s_1 , its velocity will be reduced by its friction. But S , by virtue of its great inertia, continues to move, carrying with it s_2 , which acquires a velocity in the same direction as that of s_1 . The primary current decreases; the secondary current flows in the same direction as the primary.

In this figure, S represents the ether which surrounds the wires; it is the inertia of the ether which produces the phenomena of mutual induction. The same is true of self-induction: the inertia which must be overcome in starting a current in a wire is not that of the ether which penetrates the wire, but of the ether which surrounds it.

5. Electrodynamic Attraction.— We have endeavored above to give, by analogy, an explanation of electrostatic attractions, and of the phenomena of induction. Let us now see what idea Maxwell offers as to the cause of the mutual attractions of currents.

If electrostatic attractions were due to the tension of a multitude of tiny springs, or, in other words, to the elasticity of the ether, the kinetic energy and the inertia of this fluid

would give rise to the phenomena of induction and electrodynamic actions.

The complete analysis is much too long to find place here, and we must again limit ourselves to an analogy. We shall find it in a well-known device,—the centrifugal governor. (Fig. 6.)

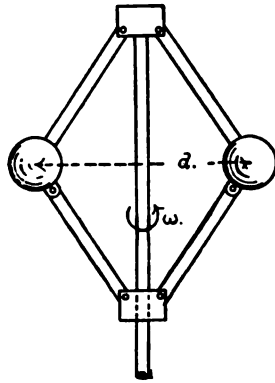

FIG. 6.—Model illustrating the mechanical action of currents. The balls tend to separate, thus increasing their kinetic energy if the angular velocity be kept constant. This energy is supplied from without in overcoming the inertia reaction due to the separation.

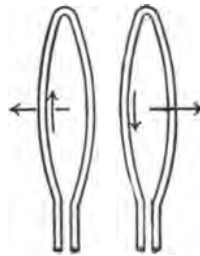

FIG. 7.—Two currents in opposite directions repel each other, tending to separate and thus increase the kinetic energy of the system for constant current. This energy is supplied from the source in overcoming the counter E.M.F. due to the separation.

The kinetic energy of this apparatus is proportional to the square of the angular velocity of its rotation, and to the square of the displacement of the balls from the axis.

According to Maxwell's hypothesis, the ether is in motion whenever there are electric currents, and its kinetic energy is proportional to the square of the intensity of the currents. This intensity thus corresponds, in the analogy which we are endeavoring to establish, to the angular velocity of rotation.

If we consider two currents in the same direction, the kinetic energy, for a given intensity of current, will become greater as the currents approach each other. If the currents flow in opposite directions, it will be greater as they are farther separated. (Fig. 7.)

This being granted, we may pursue the analogy.

To increase the angular velocity of the governor, and hence its kinetic energy, it is necessary to do work, and hence to overcome a reaction, called its *inertia*.

Similarly, increasing the strength of the currents increases the kinetic energy of the ether; and to do this requires the doing of work and the overcoming of a reaction, which is simply the inertia of the ether, and is called *induction*.

The kinetic energy will be greatest when the currents are in the same direction and close together; the work to be done in producing them and the counter-electromotive force of induction are thus greatest. This is what is meant when we say, in ordinary language, that the mutual induction of two currents is added to their self-induction. The reverse is true if the currents are in opposite directions.

If the balls of the governor be separated, energy must be supplied if the angular velocity is to be maintained; because, for a given angular velocity, the kinetic energy increases as the balls are separated.

Similarly, if two currents in the same direction be brought together, work must be done to maintain their intensity, because the kinetic energy is increased. Hence, there is an electromotive force of induction to be overcome, which tends to diminish the strength of the currents. On the other hand, it would tend to increase them if they were in the same direction and were separated, or if they were in opposite directions, and were brought together.

The mutual mechanical actions of currents may be similarly explained.

The centrifugal force tends to separate the balls of the governor, *which would have the effect of increasing the kinetic energy if the angular velocity were kept constant.*

Similarly, when the two currents are in the same direction, they *attract* each other; that is, they tend to come together, *which would have the effect of increasing the kinetic energy if the currents were maintained constant.* If the currents are in opposite directions, they repel each other, and tend to separate; which would again have the effect of increasing the kinetic energy for a constant strength of current.

Thus, the electrostatic phenomena are explained by the elasticity of the ether, and electrodynamic phenomena by its kinetic energy. But should this elasticity itself be explained, as Lord Kelvin thinks, by the rotation of minute portions of the fluid? Various considerations render this hypothesis attractive, but it plays no essential part in the theory of Maxwell, which is independent of it.

In all the preceding we have made comparisons with various mechanisms; but they are simply analogies,—indeed, rather crude ones. Moreover, we must not expect to find in Maxwell's work a complete mechanical explanation of electrical phenomena, but only a portrayal of the conditions which all such explanations must satisfy; indeed, the great element of permanency in Maxwell's work is this fact, that it is independent of all particular explanations.

CHAPTER II.

MAXWELL'S THEORY.

1. **Relations between Light and Electricity.**—At the time when the experiments of Fresnel were forcing the scientific world to admit that light is due to the vibrations of a subtle fluid, filling interplanetary space, the researches of Ampère revealed the laws of the mutual action of electric currents, and laid the foundation of electrodynamics.

It was but a step farther to suppose that this same fluid, the ether, which is the seat of luminous phenomena, is also the medium for electrical action. This step was taken by Ampère; but the illustrious physicist, in proposing his attractive hypothesis, could hardly have foreseen that it would so soon take a more precise form and begin to receive its confirmation. It was indeed only a dream without foundation until electrical measurements brought to light an unexpected fact.

The ratio of the “absolute electrostatic unit” to the “absolute electromagnetic unit” is measured by a velocity. Maxwell devised several methods for deriving the value of this velocity, and the results which he obtained fell in the vicinity of 300,000 kilometers per second; that is, the velocity of light.

The observations were soon made so precise that it was impossible to attribute the coincidence to chance, and there was no longer any doubt of the existence of some intimate relation between optical and electrical phenomena. But the nature of this relation might still have remained a mystery if the genius of Maxwell had not divined it.

The remarkable coincidence may be explained in the following way: Along a wire of perfect conductivity an electrical disturbance would be propagated with the velocity of light. The calculations of Kirchhoff, founded on the old electrodynamic theory, led to this result.

But it is not along a wire that light is propagated, but through transparent bodies, through the air, through space. Such a propagation as this was not accounted for by the old electrodynamics. Before the principles of optics could be derived from the electrodynamic theories then in vogue, the latter had to undergo serious modifications without ceasing to take account of all known facts. This reconstruction was the work of Maxwell.

2. Displacement Currents.—It is well known that material bodies may be divided into two classes: the conductors, in which we can produce displacements of electricity, that is, voltaic currents, and the insulators, or dielectrics. To the early electricians, the dielectrics were quite inert, and their function was simply to oppose the passage of electricity. If this were the case, any insulator whatever could be replaced by a different one without in the least changing the phenomena. The experiments of Faraday showed that this is not so: Two condensers of the same form and the same dimensions, connected to the same source of electricity, do not take the same charge, even though the thickness of the insulating layer be the same; provided the *nature* of the insulating material is different. Maxwell had made too profound a study of Faraday's researches to overlook the importance of the dielectrics, and the necessity of giving them their proper significance.

Moreover, if it be true that light is an electrical phenomenon, then when light is propagated through an insulating body, this insulator must be the seat of the phenomenon.

Thus there must be localized electrical phenomena in the dielectrics. But what is their nature? Maxwell replies boldly: they are *currents*.

All the known facts of his time seemed to contradict him: never had a current been observed except in a conductor. How could Maxwell reconcile his audacious hypothesis with a fact so well established? Why do these hypothetical currents produce manifest effects under certain circumstances, and yet are absolutely unobservable under ordinary conditions?

It is because the dielectrics offer to the passage of electricity, not a greater resistance than the conductors, but a resistance of a different nature. An analogy will make Maxwell's idea more intelligible.

If we undertake to compress a spring we encounter an opposing force which increases as the spring yields to the pressure. If, now, we can exert only a limited pressure, a moment will arrive when we can no longer overcome the reacting force; the movement will cease, and equilibrium will be established. Finally, when the pressure is removed, the spring will regain its original form, giving back all the energy that was expended in compressing it.

Suppose, on the other hand, that we wish to move a body immersed in water. Here again we encounter a reaction, which depends upon the velocity, but which, if the velocity remain constant, does not go on increasing as the body yields to the pressure. The motion will thus continue as long as the motive force acts, and equilibrium will never be established. Finally, when the force is removed, the body does not tend to return to the starting point, and the energy expended in moving it cannot be restored; it has been completely transformed into heat through the viscosity of the water.

The contrast is manifest, and it is important to distinguish

between *elastic* reaction and *viscous* reaction. Now, the dielectrics behave toward the motion of electricity as elastic solids do toward the motion of matter, while the conductors behave like viscous liquids. Hence there are two kinds of currents: the *displacement* currents of Maxwell, which traverse the dielectrics, and the ordinary *conduction* currents which flow in conductors.

The former, having to overcome a sort of elastic reaction, must be of short duration, for this reaction increases as long

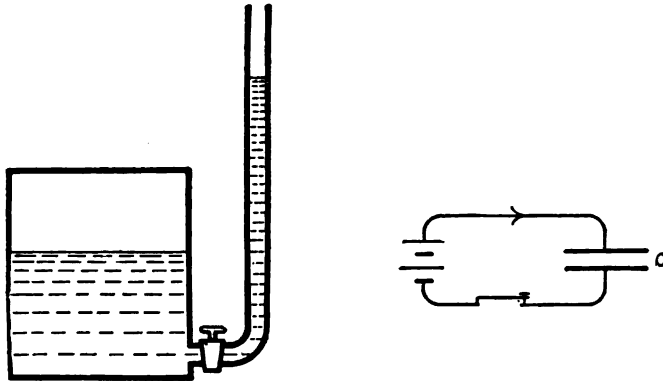

FIG. 8.— Model illustrating the flow of a displacement current in a dielectric C . The pressure in the vessel represents the voltage of the battery; the height of the column, the displacement in the dielectric; the flow of water, the charging current. The energy expended may be recovered.

as the current continues to flow and equilibrium must soon be established.

Conduction currents, on the other hand, must overcome a sort of viscous resistance, and hence may continue as long as the electromotive force which produces them.

Resuming our hydraulic analogy, suppose that we have a closed vessel containing water under pressure. (Fig. 8.) If

we put this vessel in communication with a vertical pipe, the water will rise in it, but the flow will cease when the hydrostatic equilibrium is established. If the pipe be large, there will be no appreciable friction nor loss of head, and the water thus raised may be used to do work. We have here an illustration of displacement currents.

If, on the other hand, the water be allowed to run out through a horizontal pipe (Fig. 9), the flow will continue as long as there is water in the reservoir; but, if the pipe be small, there will be a considerable loss of energy, and heat

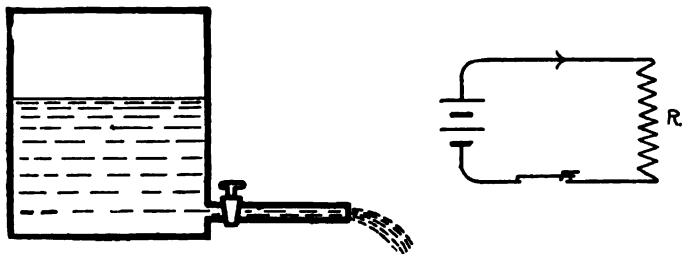

FIG. 9.— Model illustrating the flow of a conduction current in a conductor, R . The flow continues undiminished as long as the pressure is maintained. The energy expended in friction takes the form of heat and is lost.

will be produced by the friction. This illustrates the action of conduction currents.

Although it is impossible, and unnecessary, to try to imagine all the details of the mechanism, we may say that all takes place as if the displacement currents had the effect of compressing a multitude of minute springs. When the currents cease, electrostatic equilibrium is established; and the tension of the springs depends upon the intensity of the electrostatic field. The energy accumulated in these springs, that is, the electrostatic energy of the field, may be restored whenever they are allowed to unbend; and it is thus that mechani-

cal work is produced when charged conductors are allowed to obey their *electrostatic* attractions. These attractions are thus due to the pressure exerted on the conductors by the compressed springs. Finally, to pursue the analogy to the end, a disruptive discharge may be attributed to the breaking of some springs which are unable to stand the strain.

On the other hand, the energy expended in producing conduction currents is lost, and converted into heat, like the work done in overcoming friction or the viscosity of fluids. *This is why a conductor is heated by the passage of a current.*

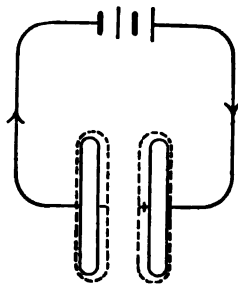

FIG. 10.—The old explanation of the charging of a condenser. The electricity was supposed to accumulate on the surface of the plates, as indicated by the dotted lines. The circuit was thus considered unclosed.

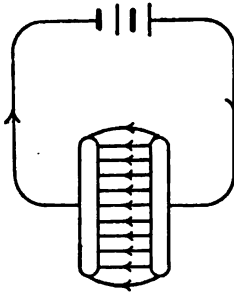

FIG. 11.—Maxwell's idea of the phenomenon of charging a condenser. The current does not stop at the surface of the conductor, but continues to flow, as a displacement current, through the dielectric, until checked by the elastic reaction. The circuit is thus completed.

From Maxwell's point of view, *none but closed currents exist*. To the early electricians, this was not the case. They considered as closed the current which circulates in a wire joining the two terminals of a battery. But if, instead of joining these terminals directly, they were connected respectively to the two plates of a condenser, the momentary current which flowed while the condenser was being charged

was considered as unclosed. (Fig. 10.) It flowed, they said, from one plate to the other through the wire connected to the battery, and stopped at the surfaces of the plates. Maxwell, on the contrary, considers that the current continues, in the form of a displacement current, across the insulating layer which separates the plates, and is thus completely closed. (Fig. 11.) The elastic reaction which the current encounters in traversing the dielectric explains its short duration.

Currents may manifest themselves in three ways: by their heating effects, by their action on magnets and on other currents, by the induced currents which they generate. We have seen above why conduction currents produce heat and displacement currents do not. Yet, according to Maxwell's hypothesis, the currents which he imagines should, like ordinary currents, produce electromagnetic, electrodynamic, and inductive effects.

Why could these effects not be observed? Because a displacement current, however feeble, cannot continue long *in one direction*; for the tension of our hypothetical springs, continually increasing, will soon check it. Thus we cannot have in a dielectric either a continuous current of long duration or a sensible alternating current of long period; but the effects should be observable if the alternations are very rapid.

3. The Nature of Light.—And here we have, according to Maxwell, the origin of light: A light wave is a series of alternating currents, flowing in a dielectric, in the air, or in interplanetary space, changing their direction 1,000,000,000,000,000 times in a second. The enormous inductive effect of these rapid alternations produces other currents in the neighboring portions of the dielectric, and thus the light waves are propagated from place to place. The ve-

locity of propagation may be shown analytically to be equal to the ratio of the units, that is, to the velocity of light.

These alternating currents are a kind of electrical vibration; but are they longitudinal, like those of sound (Fig. 12), or

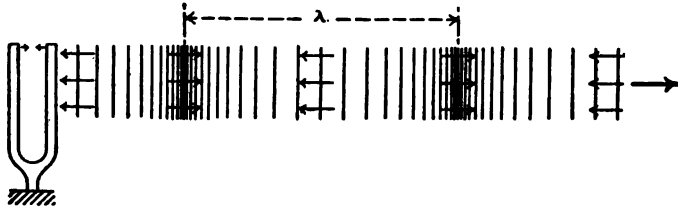

FIG. 12.— Mode of propagation of a longitudinal vibration, such as a sound wave. The crowding and separating of the parallel lines represent condensations and rarefactions of the air, and the arrows indicate the motion of individual particles.

transverse, like those of Fresnel's ether? (Fig. 13.) In the case of sound, the air undergoes alternate condensations and rarefactions; but the ether of Fresnel acts as if it were composed of incompressible layers capable only of sliding upon each other. If the currents flowed in *unclosed* circuits, the

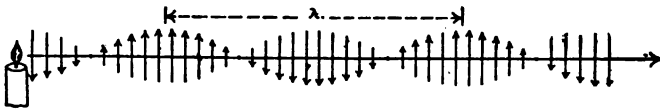

FIG. 13.— Mode of propagation of a transverse wave, such as light. There are no changes of density, and the displacements in the ether are perpendicular to the line of propagation.

electricity would necessarily accumulate at one end or the other of the circuits, and we should have a condition analogous to the condensations and rarefactions of air: the vibrations would be longitudinal. But, as Maxwell admits only closed currents, these accumulations are impossible, and the

electricity must behave like the incompressible ether of Fresnel: its vibrations must be transverse.

Thus we reach all the conclusions of the wave theory of light. This, however, was not enough to enable the physicists, who were attracted rather than convinced, to accept absolutely Maxwell's ideas: all that could be said in their favor was, that they did not conflict with any known facts, and that it were indeed a pity if they were not true. The experimental confirmation was lacking, and remained so for twenty-five years.

It was necessary to find, between the old theory and that of Maxwell, a discrepancy not too minute for our crude methods of observation. There was only one such from which an *experimentum crucis* could be derived. To do this was the work of Hertz, which we shall now discuss.

CHAPTER III.

ELECTRICAL OSCILLATIONS BEFORE HERTZ.

1. **Experiments of Feddersen.**— Alternating currents were produced at a very early date by mechanical means, such as the use of rotating commutators, vibrators, etc. These were indeed, in a sense, electrical oscillations, but their frequency was necessarily very low.

The discharge of a condenser furnished the means of obtaining much more rapid oscillations, and it was Feddersen who first demonstrated experimentally that, under certain circumstances, the discharge of a Leyden jar may be oscillatory.

Feddersen observed the spark produced in discharging a Leyden jar, by means of a rotating concave mirror. He also projected an image of the spark, by such a mirror, upon a sensitive plate, and thus photographed it under various conditions.

He varied the resistance of the circuit. With a low resistance he obtained an oscillatory discharge, and the arrangement of his apparatus enabled him to see how the frequency of oscillation varied with the capacity of the condenser and the self-induction of the circuit.

To vary the capacity he simply changed the number of Leyden jars, and thus showed approximately that the period is proportional to the square root of the capacity.

To vary the self-induction, Feddersen changed the length of the discharge circuit, and showed the period to be approximately proportional to the square root of the self-induction; but approximately only, because in his experiments the

length of the circuit reached sometimes several hundred meters; it was suspended on the wall and formed with this a condenser whose capacity was not at all negligible with respect to that of the main condenser.

As for the numerical coefficient, Feddersen could not determine its value, for he did not know accurately the capacity of his condensers; he could only verify the proportionalities.

Feddersen obtained periods of the order of 10^{-4} seconds.

By gradually increasing the resistance, which he did by inserting in the circuit small tubes filled with sulfuric acid, he obtained, first, continuous discharges, then intermittent ones; the latter for very large values of the resistance, obtained by means of wet cords.

It is evident that, in a rotating mirror, a continuous discharge should appear as a continuous band of light; an alternating or intermittent discharge, as a series of separate, bright spots.

The photographs of alternating discharges obtained by Feddersen presented a peculiar appearance. There was a series of bright and dark points corresponding to the two ends of the spark; but the luminous points for one end corresponded to the dark points for the other, and *vice versa*.

This is easily explained: When a disruptive discharge takes place in air, the particles torn from the positive electrode become incandescent, but this is not the case with the negative particles: the positive end of the spark is thus brighter than the negative.

Feddersen's photographs thus proved that each end of the spark is alternately positive and negative. Hence the discharge is not intermittent and always in the same direction, but is oscillatory.

2. Lord Kelvin's Theory.—The experiments of Feddersen may be easily explained:

Suppose two conductors (in Feddersen's experiments they were the two coatings of the condenser) to be connected by a wire. If they are not at the same potential, the electrical equilibrium will be disturbed, just as the mechanical equi-

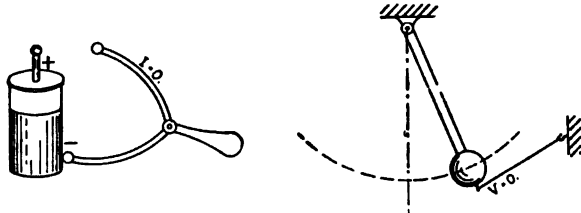

FIG. 14.—A charged condenser is analogous to a pendulum displaced from the vertical. Each represents a store of energy, ready to be released.

brium is disturbed when a pendulum is displaced from the vertical. (Fig. 14.) In either case there will be a tendency to re-establish the equilibrium. A current will flow through the wire in the effort to equalize the potentials of the two

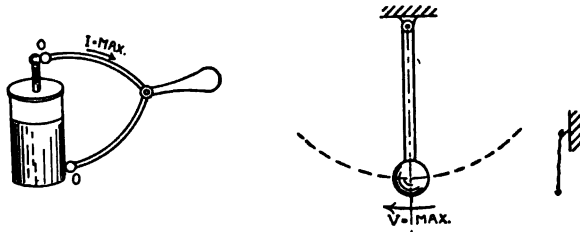

FIG. 15.—When the condenser is discharged and the pendulum has swung to the vertical, the energy is not lost, but has taken the form of current in the one case, velocity in the other. These are alike in their tendency to continue.

conductors, and the pendulum will swing toward the vertical. (Fig. 15.)

But the pendulum will not stop in the position of equilibrium; having acquired a certain velocity, its inertia will

carry it beyond this position. Similarly, when our conductors are discharged, the momentary condition of equilibrium does not last, but is at once destroyed by a cause analogous to inertia — the *self-induction* of the circuit. We have learned that, when a current ceases to flow, it induces a current in the same direction in a neighboring conductor. A similar effect is produced in the circuit of the inducing current itself, which is thus continued, as it were, by the induced current.

In other words, a current persists after the cessation of the

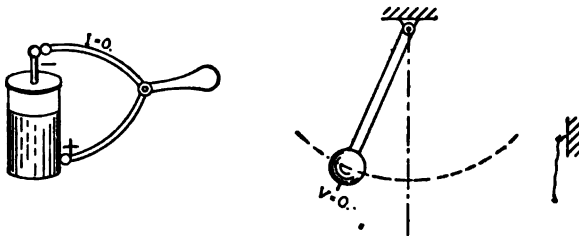

FIG. 16.—The current has ceased, and the condenser is again charged, but with reversed polarity. The pendulum has reached the extreme limit of its swing, and is ready for the return journey.

cause which produced it, just as a moving body continues in motion after the force which started it is removed.

Thus, the two potentials having been equalized, the current continues in the same direction, and charges the conductors again, but with reversed polarities. (Fig. 16.) In this case, as in that of the pendulum, the position of equilibrium having been passed, the motion must be reversed in order to return to it: again the momentary equilibrium is established, and again it is destroyed in the same way; and thus the oscillations continue.

It is readily shown analytically that the period of oscilla-

tion varies with the capacity; hence, by diminishing this capacity, which is easily done, we may obtain an "electrical pendulum" capable of producing extremely rapid oscillations.

3. Other Analogies.—In explaining the theory of Lord Kelvin we have compared the electrical oscillations with those of a pendulum, but there are many other analogies which would serve equally well.

Instead of a pendulum, take, for example, a tuning fork: if its arms be bent from their position of equilibrium, their elasticity tends to bring them back; but, impelled by their inertia, they swing past it; their elasticity brings them back again, and again they swing past, and so on: they perform a series of oscillations.

Here the elasticity of the fork plays the same part as the weight of the pendulum, and as the electrostatic force in the oscillatory discharge of the Leyden jar; the inertia of the fork takes the place of the inertia of the pendulum and the self-induction of the circuit.

But our hydraulic analogy is perhaps even better. Suppose two vessels to be joined by a horizontal tube: when the water is in equilibrium its level is the same in both vessels. But if in any way this equality of level be destroyed, it will tend to be re-established; the water will fall in vessel A, where it was above the normal level, and will rise in vessel B, where it was below the normal. The water in the tube will be set in motion, flowing from A to B. But when the equality of level is established, the motion will not cease, on account of the inertia of the water in the tube; the water will rise in vessel B and fall in A. The flow will then commence in the opposite direction, the phenomenon will be repeated in the opposite sense, and so on. (Fig. 17.)

Here again we have a series of oscillations; but what deter-

mines their period? It increases with the horizontal section of the vessels (which we shall imagine cylindrical). Thus, if a litre of water be transferred from one vessel to the other, the difference of level caused by this transfer will be less, in proportion as the cross-section of the vessels is greater. Hence the motive force will be smaller, and the oscillations slower.

On the other hand, the period will increase with the length of the tube. To transfer a litre of water from one vessel to the other, all the water in the tube must be set in motion;

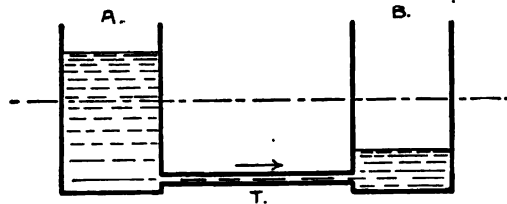

FIG. 17.—Hydraulic analogue of the oscillatory discharge of a condenser. The period depends upon the cross-section of the vessels A and B, and on the length of the tube T, which correspond to the capacity and self-induction of the circuit. If the friction in the tube is too great the flow ceases to be oscillatory. (See p. 28.)

hence the inertia to be overcome increases with the length of the tube, and the oscillations become slower.

We have seen in Chapter I that the horizontal section of the vessels corresponds to the capacity of a circuit, the length of the tube to its self-induction. The period of an electrical oscillation thus increases with the capacity and with the self-induction.

4. Damping.— The oscillations of a pendulum do not continue indefinitely; each swing is a little smaller than the preceding one, and, after a certain number of oscillations of decreasing amplitude, the pendulum comes to rest. This is due to friction.

Now, we have seen that, in electrodynamic phenomena, there is an agency which plays the same part as mechanical friction, i. e., ohmic resistance. Electrical oscillations must then decay like those of a pendulum; they must grow weaker and weaker, decreasing in amplitude, and finally cease. This diminution is called *damping*. (See Fig. 18.)

Friction does not appreciably affect the period of a pendulum; and similarly, the ohmic resistance does not, as a rule, sensibly change the period of electrical oscillations: they

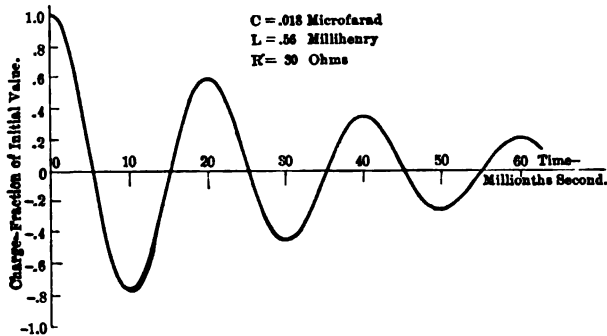

FIG. 18.—Oscillatory discharge of a condenser, calculated for the values of capacity C, inductance L, and resistance R indicated above.

grow smaller and smaller, but they do not become much less rapid.

In certain experiments, however, Feddersen employed very great resistances, and the period, as we might imagine, became notably longer. An extreme case is that in which the discharge ceases to be oscillatory. (Fig. 19.)

Imagine a pendulum immersed in a very thick and viscous fluid. Instead of descending with an increasing velocity, it moves slowly, arrives without velocity at its position of equilibrium, and does not swing beyond. There are no oscillations.

It is on this principle that aperiodic or "dead beat" galvanometers are constructed. The needle is mounted close to a plate of copper, in which Foucault currents are induced by its motion; hence the needle encounters a considerable resistance, which retards it as friction would do. Thus, instead of oscillating from one side to the other of its position of equilibrium, which would make the instrument difficult to read, it swings gently up to the point, and stops.

These mechanical illustrations will suffice to show the nature of the discharge of a Leyden jar where the ohmic

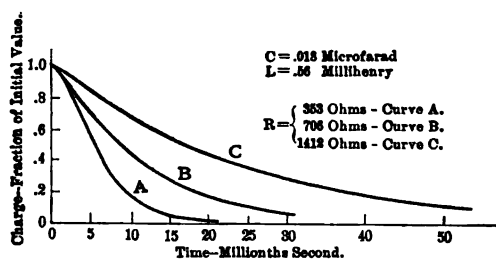

FIG. 19.—Undirectional discharge of a condenser. The conditions are the same as in FIG. 18, except for the increased resistance. Curve A is the critical case of quickest discharge. For smaller values of R the discharge becomes oscillatory. Curves B and C are for larger values of R .

resistance is very great. The condition of electrical equilibrium is attained slowly, and is not overpassed. The discharge is no longer oscillatory, but continuous. This is just what was shown by the experiments of Feddersen, which thus confirm completely the theory of Lord Kelvin.

Friction and analogous reactions are not the only causes of damping, and the kinetic energy of oscillating bodies is not all converted into heat. Consider again a tuning fork, whose vibrations diminish gradually in amplitude. Unquestionably there are frictional effects which slightly heat

the fork; but, at the same time, we hear a sound: the air is set in motion, and takes up energy from the fork. Part of the energy is thus dissipated by a sort of radiation into space.

The energy of electrical oscillations also is expended in two ways: ohmic resistance transforms a part of it into heat, but we shall soon see that another part is radiated into space without losing its electrical character. This is a phenomenon which was predicted by Maxwell's theory, and which is contrary to the old electrodynamics.

Thus we see that electrical oscillations undergo two kinds of damping: by ohmic resistance (analogous to friction), and by radiation.

CHAPTER IV.

HERTZ'S OSCILLATOR.

1. **Hertz's Discovery.**—The displacement currents predicted by Maxwell's theory could not, under ordinary circumstances, manifest their existence. As we have seen, they have to overcome an elastic reaction which increases continually as long as they continue to flow; hence they must be either very feeble, or of very short duration, *if they flow always in the same direction*. In order that their effects may be appreciable, they must change frequently in direction; the alternations must be very rapid. Industrial alternating currents, and even the oscillations of Feddersen, are entirely too slow for this purpose.

This is the reason that Maxwell's ideas waited twenty years for experimental confirmation, and to Hertz was reserved the honor of giving it. This eminent scientist, whose life was so short and so full, contemplated at first the career of an architect, but was soon drawn by an irresistible impulse toward pure science. Noticed and encouraged by Helmholtz, he was appointed professor at Karlsruhe: it is there that he made the researches which have immortalized his name, and rose in a day from obscurity to fame. But he was not destined to enjoy it long; he had barely time to complete his new laboratory at Bonn, when illness prevented him from utilizing its resources; and soon he died, leaving behind him, besides his monumental discovery, experiments of great importance on cathode rays and an original and profound book on the philosophy of mechanics.

2. Principle of the Oscillator.—The problem, as has been explained, was to obtain extremely rapid vibrations. It would seem, according to what we have seen in Chapter III, that it would only be necessary to repeat the experiments of Feddersen with diminished capacity and self-induction. It is thus that the vibrations of a pendulum are made more rapid by diminishing its length.

But it is not enough to construct the pendulum; it must be set in motion. To do this, the pendulum must be displaced from its position of equilibrium by some agency; the cause must then be removed suddenly, that is, in a time very short

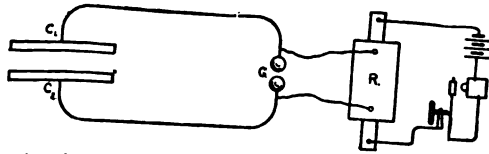

FIG. 20.—An electrical oscillator, consisting in two conductors C_1 , C_2 , joined by a wire interrupted by a spark-gap G . The conductors are charged by an induction coil R , and discharged across the air-gap.

with respect to the duration of a period; otherwise it will not oscillate.

If a pendulum be displaced from the vertical by the hand, for example; then, if, instead of letting go suddenly, the arm be relaxed slowly without releasing the pendulum, the latter will reach its position of equilibrium without velocity and will not swing beyond it.

Thus the time occupied in the release must be very short with respect to the period of oscillation; hence, with periods of a hundred-millionth of a second, no system of mechanical release could operate, however rapid it may appear with respect to our ordinary units of time.

Hertz solved the problem as follows:

Returning to our electric pendulum (see page 24), let us

cut the wire which joins the two conductors, leaving a gap of several millimeters. This air-gap divides our apparatus into two symmetrical halves which we shall connect to the two terminals of a Ruhmkorff coil. (Fig. 20.) The secondary current will charge our two conductors, and their difference of potential will increase comparatively slowly.

At first the air-gap will prevent the conductors from discharging; the air acting as an insulator and keeping our pendulum displaced from its position of equilibrium. But when the difference of potential reaches a certain point the spark of the coil will leap across the gap and open a path for the electricity accumulated on the conductors. The air-gap ceases suddenly to be an insulator, and, by a sort of electrical trigger, our pendulum is released from the cause which prevented it from returning to equilibrium. If certain rather complex conditions, thoroughly studied by Hertz, are fulfilled, the release will be sudden enough to produce oscillations.

3. Different Forms of Oscillators.— Thus, the essential parts of an oscillator are:

1st. Two terminal conductors, of relatively large capacity, which receive from the induction coil initial charges of opposite sign, and which exchange their charges at each half oscillation.

2d. An intermediate conducting wire joining these conductors, through which the electricity flows from one to the other.

3d. A spark micrometer, placed in the middle of the intermediate conductor. This is the seat of a resistance which permits the displacing of the electric pendulum from its position of equilibrium: this resistance afterward disappears suddenly when the discharge takes place, thus releasing the pendulum.

4th. An induction coil, whose terminals are connected to the two halves of the oscillator, and which furnishes their initial charges. This is, so to speak, the arm which displaces the pendulum from its position of equilibrium.

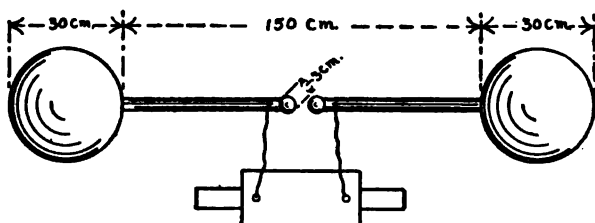

FIG. 21.—Hertz's large oscillator. Two spheres of zinc, each attached to a metallic rod terminating in a brass knob for the spark-gap.

In *Hertz's* first oscillator (Fig. 21), the two terminal conductors were spheres of fifteen centimeters radius, and the intermediate conductor a straight wire 150 centimeters long.

Hertz also used square plates instead of the two spheres. (Fig. 22.)

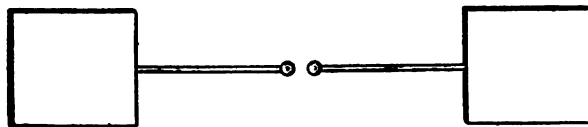

FIG. 22.—Hertz's oscillator with flat plates instead of the spherical conductors.

Bending the intermediate conductor into the form of a rectangle and bringing the two plates close together so as to form a condenser, we have the oscillator of *M. Blondlot* (Fig. 23), which he generally used as a resonator.

By simply replacing the plate condenser by a Leyden jar,

and lengthening the intermediate wire, we have the apparatus of *Feddersen*, whose vibrations are so slow that the release may be made mechanically.

Suppressing the intermediate conductor, we have *Lodge's oscillator* reduced to two spheres between which the discharge takes place; but instead of two spheres, Lodge ordinarily used three or four. (Figs. 24 and 25.) We shall see this apparatus again, much reduced in size, in the experiments of Righi and Bose, in Chapter X.

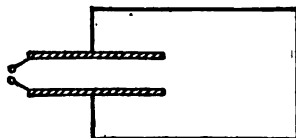

FIG. 23.—Blondlot's oscillator. The two flat conductors (Fig. 22), are brought into close proximity, so that they constitute a condenser of comparatively large capacity.

Suppressing the terminal conductors, and reducing the length of the intermediate wire to thirty centimeters, we have *Hertz's small oscillator*. (Fig. 26.) The charge, instead of being concentrated at the extremities, is distributed over the entire length of the wire.

4. Function of the Spark.— We have seen how important it is that the spark be "good," that is, that it shall leap suddenly, in a time very short with respect to the period of oscil-



FIGS. 24 and 25.—Two forms of Lodge's oscillator. In the former the oscillations play across between the two middle spheres; in the latter, they surge, like tidal waves, over the surface of the large sphere.

lation. Many circumstances influence the quality of the spark. In the first place, it must pass between two knobs; it would be bad if it passed between two points, or a knob and a point.

Again, the surfaces of the knobs must be well polished. In air they oxidize rapidly and must be frequently cleaned.

Finally, the knobs must be separated by the proper distance; indeed, it is this which limits the amplitude of the oscillations. In order to give strong oscillations, our pendulum must be displaced considerably from its position of equilibrium; that is, the two halves of the oscillator must receive considerable charges before the spark occurs.

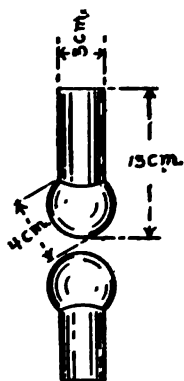

FIG. 26.—Hertz's small oscillator, consisting in two short brass rods terminating in spheres at the inner ends.

Now, the discharge will take place when the difference of potential reaches a certain value, depending upon the length of the air-gap; hence, we would naturally be led to increase this distance; but if this is done, the spark ceases to be good.

After a little practice, it is easy to distinguish good from bad sparks by their appearance and sound.

5. Influence of Light.—Hertz observed another curious effect,—the primary and secondary sparks seemed to act mysteriously upon each other. When a screen was placed between the two, the secondary spark ceased to occur. Hertz thought at first that this was due to some electrical action, but he perceived later that the phenomenon was caused by the light of the spark.

Yet a plate of glass, which allows light to pass, prevented the action of the sparks upon each other. This was because the active rays, in this case, are the ultra-violet, which are absorbed by the glass; in fact, a plate of fluorite, which is transparent to ultra-violet rays, does not prevent the action of the primary spark.

6. The Use of Oil.— MM. Sarasin and de la Rive made a great advance, in causing the discharge to take place in oil. The knobs of the micrometer no longer become oxidized, the incessant cleanings are not necessary, and the sparks are much more regular. Moreover, the disruptive potential being greater than in air, the electrical pendulum may be further displaced before it is released by the discharge. The amplitude of the oscillation is thus increased.

7. Value of the Wave-length.— Various theoretical considerations enable us to calculate that Hertz's large oscillator, described above, produces oscillations whose frequency is 50,000,000 cycles per second.

We know that the wave-length of an oscillation is the distance traversed by the disturbance in the time of a complete oscillation; hence, if the velocity of propagation is the same as that of light, that is, 300,000 kilometers per second, the wave-length will be the fifty-millionth part of 300,000 kilometers, or 6 meters.

In the same way we may predict that Hertz's small oscillator will give vibrations ten times as rapid, and consequently of one-tenth the wave-length.

We shall see further on that these theoretical conditions have been confirmed by the direct measurement of the wave-lengths.

CHAPTER V.

METHODS OF OBSERVATION.

1. Principle of the Resonator.—An oscillator produces in the space surrounding it displacement currents and phenomena of induction; or again, it produces by induction a disturbance at one point of a wire, and this disturbance is propagated along the wire. It remains to be seen how these facts may be observed.

For this purpose a resonator is generally used. When a tuning fork vibrates, its vibrations are communicated to the surrounding air; and, if there be in the vicinity another fork in tune with the first, this also will commence to vibrate. In the same manner, an electrical oscillator produces a disturbance in the surrounding medium, and causes a second oscillator in the vicinity to respond, if their periods of oscillation be the same. The second oscillator thus becomes a resonator.

But there is a great difference between acoustic resonance and electrical resonance. An acoustic resonator responds readily to vibrations which are exactly in unison with it; the resonance is practically nil if their periods differ, however slightly. An electrical resonator responds readily to impulses with which it is in tune, not quite so well to those whose period is a little different from its own, and poorly to those which are notably discordant.

The reason for the difference is this: Acoustic vibrations have a small decrement — their amplitude is nearly constant — while electrical vibrations are damped rapidly. This is why the electrical resonance is weaker and less marked.

A resonator is simply an oscillator without the induction

coil, which is now useless; for the function of the coil is to charge the oscillator, while, in this case, it is the external field which excites the oscillations in the resonator.

Furthermore, any form of oscillator may be used as a resonator. Ordinarily the two terminal conductors are dispensed with, and in most cases one or other, of two forms is used: the *open resonator* in which the conductor is a straight wire (A D, Fig. 28), and the *closed resonator*, which is bent in a circle with the ends of the conductor almost meeting. (Fig. 27.)

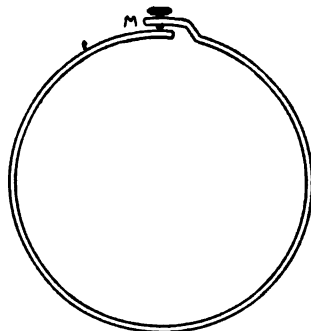

FIG. 27.—A closed resonator as used by Hertz. M is a micrometer screw for measuring the length of the induced spark.

2. Operation of the Resonator.

— When a sound is produced in an organ pipe it is reflected at one end, returns in the opposite direction, is again reflected at the other end, and so on. All these reflected waves interfere with each other, adding their effects if they be in accord, destroying each other when in opposition. Thus certain tones are reinforced and others are extinguished.

The operation of an electrical resonator is quite similar; the disturbance travels along the wire, is reflected at each end, and the cumulative effect of all these reflected waves, traveling to and fro, is to reinforce those vibrations whose period is suitable.

We have shown above why it is necessary to furnish an oscillator with an interrupter which releases the electrical pendulum suddenly. The same considerations do not apply here, for it is the external field which excites the resonator.

But it is not sufficient to have oscillations in the resonator, we must be able to detect them; and the spark furnishes a convenient means of observation. Hence we retain a spark-gap in the middle of the open resonator. With the closed resonator it suffices to bring the ends close enough together to allow the spark to pass. Thus, when the amplitude of the oscillations reaches a certain point, the difference of potential between the ends of the resonator may be sufficient to cause a spark to leap across the air-gap, and in this way only do we become aware of the existence of the oscilla-

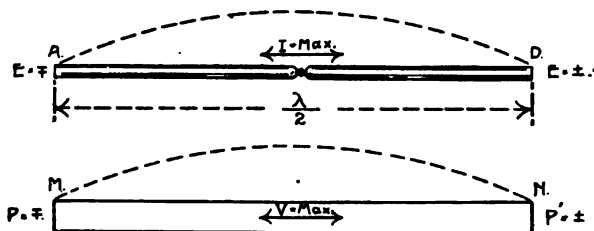

FIG. 23.—An open resonator, AD, compared to a sonorous tube, MN, closed at both ends. The current, which is analogous to the velocity of the air, is a maximum in the middle, but is zero at the ends, as indicated by the dotted curves. The wave-length, λ , is twice the length of the resonator.

tions. It is as if we had a vessel containing water in motion, but were unable to observe the disturbance except when it became so great as to splash part of the water out of the vessel.

The secondary sparks produced in the resonator are much smaller than the primary sparks of the oscillator — they are only a few hundredths of a millimeter in length.

If a tube closed at both ends contain a vibrating column of air, the half wave-length of the vibration is equal to the total length of the tube; and, by analogy, the half wave-length of the free oscillation of a resonator should be the

total length of the wire, if its ends have no capacity. The ends of the conductor are thus comparable to the closed ends of the sonorous tube; for the current must be zero at these points, beyond which the electricity cannot pass, and where it cannot accumulate. (Fig. 28.)

This ceases to be true when the capacity of the ends of the conductor is appreciable, and for this reason the half wave-length in a closed resonator is a little greater than the length of the conductor.

We can now understand the operation of an open resonator. Given a wire, A D, broken in the middle by a spark-gap,

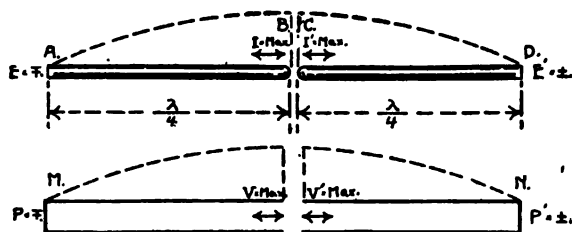

FIG. 29.— Before the spark occurs in the resonator, the two halves, though separate, affect each other across the spark-gap. The current is still maximum at the inner ends, B, C, and each half vibrates like a closed organ pipe, with a wave length, $\lambda = 4 \times AB = 4 \times CD = 2 \times AD$.

B C. (Fig. 29.) This gap is very short — only a few hundredths of a millimeter. The end B of A B, and the end C of C D are thus, as it were, the plates of a condenser, separated by a very thin layer of dielectric, and hence of considerable capacity. Consequently, they correspond rather to the *open* end than to the closed end of a sonorous tube.

If a spark passes, the whole resonator, A D, vibrates like a tube with both ends closed, and the half wave-length is A D. If the spark does not pass, the two halves, A B and C D, of the resonator vibrate separately, but after the man-

ner of a tube with one end closed and the other open. The half wave-length is thus twice AB , that is, equal to AD , as before.

3. Other Methods of Using the Spark.—The use of a resonator, which distorts the wave by exaggerating certain harmonics, may be avoided as follows:

Suppose the disturbance to be propagated along a wire, two points of which are brought close together. (Fig. 30.) The

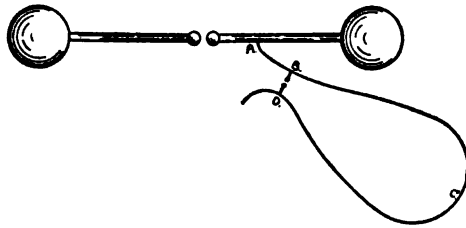

FIG. 30.—A method of investigating wave forms. A current from the oscillator travels along the wire $ABCD$, a loop of which is bridged by a spark-gap, BD . Owing to the finite velocity of propagation there will be a difference of potential between B and D , of which the spark-length is a measure.

wave will reach one of these points before the other, hence there will be a difference of potential between them; and if this difference be sufficiently great, a spark will leap across. This method was used by MM. Pérot and Birkeland, who, by varying the length of conductor comprised between the two sides of the spark-gap, obtained sufficient data for determining the form of the wave.

Whether a resonator be used or not, it is evident that the spark furnishes a means of measurement. The distance between the knobs of the spark-gap may be varied by means of a micrometer screw, and the distance over which the spark will leap thus determined. (Fig. 31.)

The phenomenon becomes much more brilliant if a Geissler tube be used; indeed a tube containing rarified gas is illuminated when it is simply placed in the alternating field produced by an oscillator.

4. Thermal Methods.— Instead of observing the sparks we may study the heating effect of the oscillating currents, either in a resonator or in the wire along which the wave is propagated.

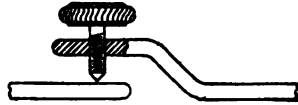

FIG. 31.— A spark micrometer as used by Hertz in connection with the resonator shown in Fig. 27.

For measuring the heating of conductors three methods are available:

First. Measuring the elongation of the conductor;

Second. Measuring the variation of resistance;

Third. The use of thermo-electric couples.

(1.) The measurement of elongation is not accurate, notwithstanding the ingenious devices that have been used; hence we shall not consider this method, nor the experiments based on the motion of heated air in a tube surrounding the conductor.

(2.) Measuring the change of resistance gives better results. The bolometric method is used: an ordinary Wheatstone bridge has all of its branches traversed by the current of a battery, and in addition, the oscillating current is sent through one of them. (Fig. 32.) Suppose the galvanometer to stand at zero, and then pass the oscillations through one arm of the bridge: this arm is heated, its resistance increases, the equilibrium is destroyed, and the galvanometer is deflected.

(3.) The oscillating current is caused to traverse a fine wire, near which (about one-tenth millimeter away) is placed a thermo-pile. This method is very delicate.

5. Mechanical Methods.—Mechanical methods, whether founded on electrostatic attractions or on the mutual action of currents, seem at first sight incapable of detecting Hertzian oscillations. These oscillations are so rapid that no

mechanical device can follow all the variations of the electrical or magnetic phenomena; all that can be obtained is a mean value of the phenomenon.

But a galvanometer, for instance, receiving a series of alternate impulses in opposite directions, would remain at rest; the mean value of the phenomenon would be zero.

Again, if the quadrants of an electrometer be connected to the apparatus producing the oscillations and the needle

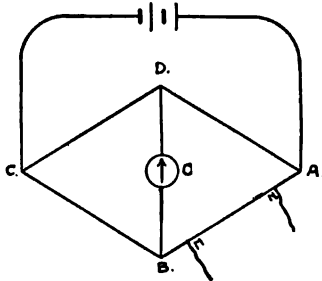

FIG. 32.—Bolometric method of measuring oscillations. The fine wire MN carrying the current to be measured is inserted in the arm AB, and the bridge balanced. Any heating due to the oscillations in MN will cause a deflection.

charged to a constant potential, the electrification of the quadrants will be continually changing sign while that of the needle is constant; their mutual action will be continually reversed, and its mean value will be zero.

In order to obtain a deflection, Herr Bjerknæs used another arrangement. He employed a quadrant electrometer with all but two opposite quadrants removed. These were connected respectively to the two terminals of a resonator so arranged as to give no sparks. The needle of the electrometer was insulated.

At a given moment the needle is charged inductively with positive electricity at one end, and with negative at the other, and the quadrants exert a certain action upon it. A half-period later the charges of the quadrants have changed

sign, but the induced electrification of the needle is also reversed, so that the direction of the action is not changed.

6. Comparison of the Different Methods.—There is an important difference between the methods founded on the spark and the thermal or mechanical methods.

The spark simply occurs, or does not occur; and in order that it may occur, it suffices that the potential be sufficiently high *at any instant whatever* to break down the air-gap. Hence it tells us only the *maximum amplitude* of the oscillation.

The thermal and mechanical methods, on the other hand, give us integral values: they indicate a *mean* amplitude* depending upon the values of all the oscillations.

Herr Bjerknæs, by employing both methods simultaneously, succeeded in measuring the damping of the free oscillations of a resonator. It is clear that, the greater the decrement of an oscillation, the smaller is the ratio of the mean amplitude to the maximum: thus, by comparing the results of the two methods of measurement, we may determine this ratio.

7. Coherers.—Branly devised a detector which is much more sensitive than any of the foregoing. It is based on an entirely different principle, and is known as the "coherer" or "radio-conductor."†

Imagine a glass tube of rather small bore filled with metallic filings. Each of the metallic particles is, in it-

* The word (*moyenne*) in the original does not convey the strict idea of "average" or "arithmetical mean," for it is the mean square that is generally indicated in such measurements.—F. K. V.

† The name "radio-conductor," given to this apparatus by Branly, implies nothing regarding the nature of the phenomenon involved, but simply that the tube becomes a conductor under the influence of the radiations. The name "coherer," introduced by Lodge, though assuming more definite knowledge on the disputed question, is more generally used.—F. K. V.

self, a good conductor, but the electricity encounters a considerable resistance in passing from one to the other, so that almost the entire resistance of the apparatus is seated in the points of contact between the particles.

Now, experiment shows that the resistance is greatly diminished when the apparatus

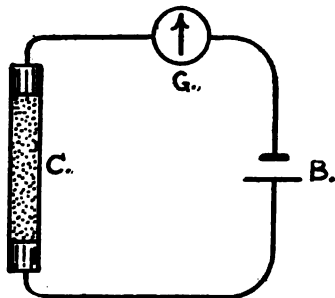

FIG. 33.— Early form of filings coherer, C. with galvanometer G and battery B.

is exposed to Hertzian radiations — that is, to the inductive forces which proceed from a Hertzian oscillator, and which change sign a great number of times per second.

We shall not attempt to explain this phenomenon*: suffice it to say that similar effects have been observed on exposing a coherer, not to Hertzian radiations, but to other influences of an entirely different nature, though periodic in character and of very short period, such as certain sound waves.

Whatever the explanation, the Hertzian radiations act as if they produced a more intimate contact between the metallic particles. A jar or an elevation of temperature restores the coherer to its original condition of high resistance.

Suppose now a coherer to be connected in circuit with a battery and exposed to the radiations produced by an oscillator. (Fig. 33.) When the oscillator is not working, the coherer is traversed only by the continuous current of the battery. If, now, the oscillator be put in operation, the coherer will be traversed also by rapidly alternating currents produced

* For the results of recent experiments, see pages 179-185.

by induction from the oscillator; but, in this case, as the alternating currents diminish the resistance, the continuous current is greatly increased, and a galvanometer in the circuit will show a marked deflection.

Branly's detector may be compared to the bolometer described above: in each apparatus the oscillations have the effect of changing the resistance of a conductor traversed by a continuous current, but the variation is due to quite different causes: in the one case, to the heating of the wire; in the other, to a more intimate contact between the particles of metal.

Moreover, the coherer is vastly more sensitive; we shall see it again in the experiments of Bose in Chapter X; indeed, it is this device that has made wireless telegraphy possible.

The coherer has been used in the effort to determine whether Hertzian radiations are emitted by the sun, but the results were negative. Perhaps these radiations are absorbed by the solar atmosphere.

Experiments show unquestionably that gases under ordinary pressures are quite transparent to these radiations: but is this the case with highly rarified gases? We have seen that a Geissler tube glows in the field of an oscillator. It does not give light without absorbing energy; hence rarified gases absorb Hertzian radiations, and it is possible that those which the sun may emit are absorbed by the upper strata of the two atmospheres, where the pressure is very low.

CHAPTER VI.

PROPAGATION ALONG A WIRE.

1. **Production of Waves in a Wire.**—A Hertzian oscillator produces forces of induction in the field which surrounds it. If we place a long wire in this field, the forces of induction will generate alternating currents in the part of the wire nearest to the oscillator, and this electromagnetic disturbance will travel along the wire.

To force the electromagnetic disturbances to follow the

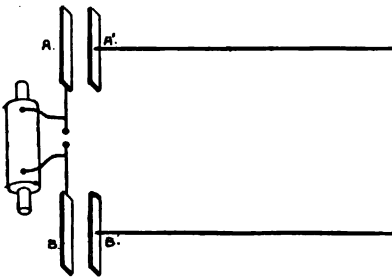

FIG. 34.—Hertz's method of establishing waves in wires. The plates A and B of the oscillator act electrostatically upon two similar plates, A'B', to which the wires are attached.

wire several devices may be used, among which we may mention the electrostatic method of Hertz, and the electromagnetic method of M. Blondlot.

Hertz's method.—The spheres of the oscillator are replaced by two metal plates, A and B (Fig. 34), of large capacity; opposite these are placed two similar ones, A' and B', and at the middle of each of the latter is attached a wire of a certain length. The capacities of the plates A and B are thus increased by causing each to form part of a condenser.

If the oscillator be put in operation, one of the plates, say A, will be charged positively, and B negatively. At the end of a half oscillation the charges will have changed sign; and so on, the polarity changing with each half-period.

The plates A' and B' are charged inductively with opposite signs to those of A and B, and the wires proceeding from them become the seat of an oscillatory phenomenon of the same period as that of the oscillator.

M. Blondlot's method.—The oscillator takes the form of a curved wire ending in a sort of condenser. (Fig. 35.) Around this first wire is bent another, whose ends are carried out radially to a considerable distance. The two circular conductors are insulated from each other by a covering of rubber.

When the oscillations are produced, the oscillator is the seat of periodic currents which excite induced currents of the same period in the second conductor.

2. Mode of Propagation.

—Is the propagation of a Hertzian oscillation, that is, of an alternating current of very high frequency, similar in every respect to the propagation of a continuous current, such as is furnished by a battery?

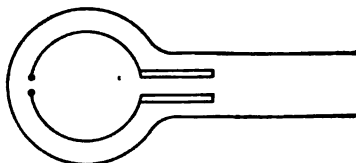

FIG. 35.—Blondlot's method. The wire which connects the plates of the oscillator is bent into a circle, and acts inductively upon another loop concentric with it, to which the wires are attached.

One striking difference was observed long ago by experimenters: a continuous current distributes itself uniformly over the whole section of the conductor; but this is not the case, even with the low-frequency alternating currents employed in the arts. In the axis of the conductor the current is very weak, while its intensity is much greater at the surface. It is as if the surface current shielded the interior of the conductor from external actions, by the forces of induction which it produces.

With Hertzian oscillations, whose period is very much

shorter, we should expect to see the phenomenon exaggerated. There should be no current except in a very thin superficial layer. Bjerknes verified this prediction in an ingenious manner.

We have seen (page 45) how this scientist measured the damping of a resonator. This damping depends upon the material of which the resonator is made: it is not the same for a resonator of iron as for one of copper.

Bjerknes plated his iron resonator, by electrolysis, with a coating of copper, and the copper resonator with a coating of iron. When the thickness of the coating was greater than a hundredth of a millimeter, the iron resonator acted like one of copper, and the copper resonator like one of iron.

This showed that the currents are confined to a shell whose thickness is of the order of a hundredth of a millimeter. This effect is in accord with both the old theory and that of Maxwell.

But Maxwell's theory predicts another peculiarity, which, unfortunately, hardly admits of direct experimental proof. The alternating currents which flow in a wire produce forces of induction in the surrounding air. According to Maxwell, these forces of induction should generate displacement currents in the air itself.

Thus, with continuous currents, we have conduction currents through the whole mass of the conductor and none at all in the surrounding air. With high-frequency alternating currents, on the other hand, there are conduction currents in the superficial layer of the conductor, none in the interior, and displacement currents in the air.

3. Velocity of Propagation and Diffusion.—Kirchhoff undertook to compute the velocity of propagation of any electrical disturbance whatever. He assumed, at the start, that the conductor was perfect, and that the current, encounter-

ing no ohmic resistance, would only have to overcome the self-induction, which acts like inertia. He showed that, under these conditions, the velocity of propagation would be equal to the ratio of the units — that is, to the velocity of light — 300,000 kilometers per second.

Moreover the propagation is uniform: if the disturbance be confined originally to a certain part of the wire, one meter long, for example, at the end of a hundred-thousandth of a second the front of the wave will have advanced three kilometers, and the tail of the wave also three kilometers; so that the extent of the disturbance will not be changed, but it will still occupy just one meter of the conductor.

But these theoretical conditions are never realized in actual conductors, for, besides the self-induction, there is always an ohmic resistance analogous to friction to impede the current. What happens then? The front of the wave advances always with the same velocity — that of light; but the tail of the wave travels much less rapidly, so that the space occupied by the disturbance becomes greater and greater: just as a caravan is spread along the road by the lagging behind of followers. This is called the *diffusion of the current*.

The diffusion becomes less noticeable as the period of the oscillations is shortened. Practically we may say that, with Hertzian waves, there is no diffusion, and that all conductors behave as if they were perfect. Not that their ohmic resistance is less, for it is actually greater, as the current utilizes only the thin outer shell of the conductor; but the effect of the self-induction, which depends upon the variations of the current, increases much faster when these variations are extremely rapid, and thus the ohmic resistance becomes negligible with respect to the self-induction.

These are the effects for which the old theory and that of

Maxwell both provide,— they are agreed on this point. We shall now see that these predictions are confirmed by experiment.

4. **Experiments of MM. Fizeau and Gounelle.**—Fizeau and Gounelle's experiments were made in 1850, with an apparatus based on the same principle as the celebrated method of Fizeau for measuring the velocity of light.

A disc of wood, having its circumference divided into thirty-six sectors of alternating wood and platinum, is caused to rotate with great rapidity. (Fig. 36.) Two wires, each

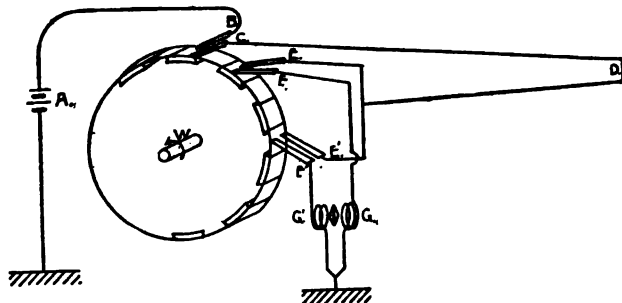

FIG. 36.—Fizeau and Gounelle's method of measuring the velocity of propagation of a current in a wire. W is a rotating commutator, having three pairs of brushes, BC, EF, E'F'. CDE is the line wire, and GG', a differential galvanometer.

terminating in a metallic brush which bears upon the circumference of the disc, may thus be alternately connected and insulated from each other, as the disc rotates. There were three such pairs of brushes, B and C, E and F, and E' and F', so arranged that the connections between B C and E F were opened and closed at the same time, while the connection E' F' was closed when the other two were open, and *vice versa*.

A battery was connected with one terminal to the ground and the other to a wire A B, attached to the brush B. A

long line wire, C D E E', ran from brush C to the end of the line D, and returned to the brushes E and E'. Finally, two wires F G and F' G' connected the brushes F and F' to the ground.

Let us now see what would take place if the electricity were propagated with a perfectly definite velocity, like light or sound. We shall denote as a "period" the time which elapses from the moment one of the brushes comes in contact with a sector until the contact ceases — that is, the thirty-sixth part of the time of one rotation of the disc. This period will decrease as the speed of rotation increases.

Suppose the time T, required for an impulse to travel the length of the line C D E, to be equal to an even number of periods. The electricity coming from the battery will pass from B to C at the moment the connection B C is closed, will traverse the line, and arrive at E and E' at the end of time T. At this moment the connection E F will be closed and E' F' open, so the current will pass through the wire F G.

If, on the other hand, T be equal to an odd number of periods, the current, on reaching E and E' will find E F open and E' F' closed, and the current will pass through the wire F' G'.

Thus the speed of rotation could be adjusted so that the whole current would pass through F G, or through F' G'; or, for intermediate velocities, the current would be divided in different proportions between the two wires.

The wires F G and F' G' included respectively the two coils of a differential galvanometer, on whose needle they acted in opposite senses; so that the deflection of the galvanometer indicated the comparative strength of the intermittent currents in the two wires. The experimenters were thus enabled to determine what velocity of rotation was

necessary to make T equal to a given multiple of the period, and hence to measure T , which gave them the velocity of propagation.

Various circumstances, to which we shall refer later, arose to complicate the phenomena, and it was found that the current in $F G$ (or $F' G'$), could never be reduced to zero, but showed only a succession of maxima and minima, of which the former alone could be determined.

The observations of Fizeau and Gounelle gave 100,000 kilometers per second for the velocity in iron, and 180,000 kilometers per second for copper.

5. Diffusion of Currents.—It has been noted that the current could never be reduced to zero, as would be the case if the impulse traveled with a perfectly definite velocity. It appears rather that the wave spreads out as it travels, so as to occupy more space on the wire when it arrives than it did at the start. This phenomenon, which the experiments of Fizeau established beyond a doubt, was called by him the "diffusion" of the current.

We have seen above (page 51), the ground on which this phenomenon might have been predicted. The consequences follow readily. The wave must travel as if a part of the electricity moved with the velocity of light, while the rest followed at a lesser, and variable, velocity. The result would be, as it were, a column with a strong front, advancing at a velocity of 300,000 kilometers per second, but leaving behind laggards straggling along the road.

The method of Fizeau measured, not the maximum velocity — that of the head of the column — but the mean velocity, which should be much smaller. This explains why his results are so far below 300,000 kilometers.

The mean velocity in iron is less than in copper, for two reasons:

First, because iron is magnetic, and the self-induction is increased by reason of the transverse magnetization of the wire; *second*, because the specific resistance of iron is greater than that of copper, and hence the diffusion is greater.

Fizeau's experiments are thus not in conflict with the theory.

6. Experiments of M. Blondlot.—The above discussion indicates how different is the propagation of a continuous current, or of an intermittent or alternating current of low frequency, from the propagation of Hertzian waves.

These last are of very short duration and consist in oscillations of extremely high frequency. We may well surmise that the effect of diffusion is negligible, the residue lagging behind very small, and the mean velocity of propagation extremely close to that of the wave-front, that is, 300,000 kilometers per second.

But the experiments just described did not justify any conclusions regarding waves of this kind. Further researches were necessary, and thus M. Blondlot was led to undertake the following experiments:

His apparatus comprises two symmetrical Leyden jars, F and F', of small capacity. (Fig. 37.) The interior coatings, A and A' are joined by a wire, broken in the middle by a spark micrometer. The two knobs of the micrometer are connected to a Ruhmkorff coil. The coatings A and A' of the Leyden jar, the conductor which joins them, and the spark micrometer constitute an oscillator, which we shall call E.

The outer coating of each of the jars F and F' is divided into two insulated sections. We shall denote as B and C the two sections of the outer coating of F, and B' and C' those of the outer coating of F'.

B and B' are connected in two manners:

First. By a moistened cord;

Second. By a short wire, containing a spark micrometer at its middle point. The terminals of the spark-gap are two metallic points, P and P'.

Similarly C and C' are connected in two ways:

First. By a moistened cord;

Second. By a line wire. This wire runs from C to a point D at the end of the line, then returns to the point P, mentioned above; after traversing the micrometer, the electricity

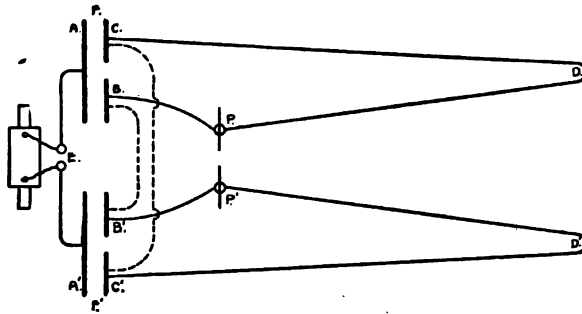

FIG. 37.—Blondlot's method of measuring the velocity of high frequency waves in wires. A and A' represent the inner coatings of two Leyden jars, connected together through a spark-gap, and constituting an oscillator, E. BC and B'C' are the outer coatings, each divided into two sections. CDP and C'D'P' are the line wires, and PP' two points between which leaps the secondary spark, which is observed in a rotating mirror. The dotted lines represent wet cords.

must pass from P' to a point D', at the end of the line, returning then to the coating C' of the jar F'. The poles of the line thus support four wires, CD, DP, P'D', D'C'; and the electricity, in passing from C to C' by this route, passing through the micrometer, must traverse the length of the line four times: twice in going, twice in returning.

Thus there are two routes from B to B' or from C to C'; the one through a wet cord of high resistance, the other through a metallic circuit, interrupted by a spark-gap.

If the variations of potential are slow, the current will pass entirely by the moist cord; for the difference of potential between the points P and P' will not be great enough to cause a spark to leap, and the micrometer will remain an insulator.

If, on the other hand, the variations of potential are rapid, a spark will leap, opening a path for the electricity across the micrometer: almost the entire current will pass by the metallic circuit, while the cord will carry only a negligible amount, owing to its high resistance.

The apparatus operates as follows:

The Ruhmkorff coil charges the inner coatings, A and A', of the jars; say A positively and A' negatively. The coatings B and C are charged negatively by induction; the coatings B' and C', positively. Hence a quantity of electricity must flow from B to B' and from C to C'; but, as the variations of potential are comparatively slow, it will flow through the moist cords.

At a certain moment a spark will pass in the oscillator E. This discharge is oscillatory, as its appearance plainly shows. The coatings A and A' are discharged suddenly, and the charges accumulated on B and C, B' and C', are suddenly and simultaneously liberated. Currents will thus flow back from B' to B and from C' to C, but this time following the metallic circuit, for their variations are sudden.

Two sparks will pass in the micrometer P P', which is the common part of the metallic circuits B B' and C C'. The first spark will pass at the moment the disturbance starting from B arrives at P; the second, when the disturbance starting from C arrives at P. As the path B C is very short, the interval of time elapsing between the two sparks will be the time required by the disturbance to traverse the path C D P. This length, C D P, we shall call the length of the line. It

is double the length of the wire C D, which runs to the end of the line, and half the total length of the circuit C D P P' D' C'.

The time interval between the two sparks was determined by means of a rotating mirror which threw the light of the sparks upon a sensitive plate, and the distance between the two images on the plate was measured.

The first experiments, in which the length of line was a little over one kilometer, showed, on an average, a velocity of 293,000 kilometers per second; later, with a length of line of 1,800 meters, an average velocity of 298,000 kilometers was obtained.

CHAPTER VII.

MEASUREMENT OF WAVE-LENGTH AND MULTIPLE RESONANCE.

1. **Stationary Waves.**—The experiments above described show that the velocity of propagation along a wire is the same as that of light. To determine the number of vibrations per second it remains to measure the length of wave, and to divide by this length the distance traversed in a second, i. e., 300,000 kilometers.

To this end, Hertz undertook to utilize the phenomenon of stationary waves.

Suppose a periodic disturbance to travel along a wire: when it reaches the end of the wire it will be reflected and will return in the opposite direction. The resulting disturbance may be obtained by combining the direct and reflected waves. Two periodic waves are added together when they are of the same phase; that is, when the alternating currents which accompany them are both positive or both negative at the same time: they annul each other when they are of opposite phases; that is, when the currents accompanying one are positive while those of the other are negative, and *vice versa*.

The two waves, direct and reflected, are of the same phase and are added if the difference between the distances which they have traveled is an integral number of wave-lengths*;

* The author evidently had in mind the case where the wave is reflected from a capacity (Fig. 38): when the reflection occurs at the free end of a wire, the positions of nodes and loops are interchanged. (Fig. 39.) See below.—F. K. V.

the corresponding points of the wire, where the action is a maximum, are called "loops," or "antinodes."

The two waves are opposite in phase, and mutually destructive, when the difference between the distances traveled is an odd number of half wave-lengths: the corresponding points of the wire, where the action is nil, are called "nodes."

The distance between two consecutive nodes is equal to a half wave-length.

Let A and B be two such nodes. (Fig. 38.) At A, the difference between the distances traveled by the two waves is

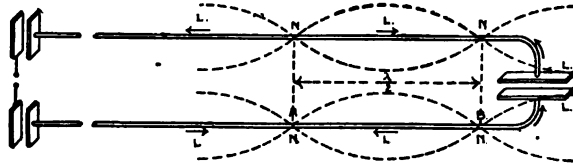

FIG. 38.—Formation of stationary waves in wires terminating in a large capacity. N, N are nodes, where the current is zero, and L, L are loops, where the current reaches a maximum. The ordinates of the dotted curves indicate relative values of the current. $AB = \frac{\lambda}{2} = \text{half wave-length}$.

equal to an odd number of half wave-lengths, say $2n+1$. The direct wave passes A before reaching B; the reflected wave passes B before reaching A. When we move from A to B the distance traversed by the direct wave is increased by the length AB, while the distance traversed by the reflected wave is diminished by AB. Thus the difference between the distances traveled is diminished by $2 \times AB$. Now, as the point B is a node, this difference also must be an odd number of half wave-lengths, $2n-1$. Thus $2 \times AB$ must be precisely equal to a wave-length.

Such is the phenomenon of stationary waves as it was at

first understood by Hertz, who hoped to find in it a simple method of measuring wave-lengths.

Unfortunately, as we shall now see, the matter is somewhat more complicated.

Reflection at the end of a wire may take place in different ways. If the wire simply terminates abruptly, without capacity, the electricity cannot accumulate at the end, and the current at that point must be zero. The end of the wire is a node. (Fig. 39.)

If, on the other hand, the wire terminates in a considerable capacity — for example, if the two parallel wires shown

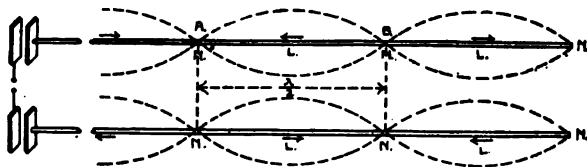

FIG. 39.—Formation of stationary waves in wires which terminate abruptly. The positions of nodes and loops are reversed with reference to those of FIG. 38.

on pages 48 and 49, be connected to the two plates of a condenser — then the end is a loop. (Fig. 38.)

Again, the ends of these two parallel wires may be joined. A wave which has traversed one of the wires in the positive sense returns by the other in the negative sense, and, interfering with the positive wave following the second wire, produces stationary waves.

2. Multiple Resonance.—We have seen (page 38) that a resonator responds readily to an oscillator with which it is perfectly in tune, but that it also responds, though less readily, to an oscillator of different period.

Consequently, it is possible to work with an oscillator

and a resonator whose periods differ considerably. This was done by MM. Sarasin and de la Rive.

They discovered an unexpected law, which they called the "law of multiple resonance." The internode, or distance between two nodes, which, according to the preceding paragraph, should be the measure of the half wave-length, changes when different resonators are used with the same oscillator, but remains the same when the oscillator is changed while using the same resonator. Hence, that which is measured must be something pertaining to the resonator itself; in fact, the internode is the half wave-length of the free oscillations of the resonator — not of those produced by the oscillator.

The following is the explanation offered by MM. Sarasin and de la Rive: The wave produced by the oscillator is complex, and results from the superposition of an infinity of simple vibrations, which may be called its components. Such is the radiation of a luminous body which produces, not monochromatic light, but white light, giving a continuous spectrum.

Each resonator responds to only one of these components, and when a resonator is used to measure a wave-length, it is the wave-length of this component which is obtained: the other components have no effect on the result. In other words, we measure the wave-length of the free oscillation of the resonator.

In like manner in acoustics, a complex sound made up of several harmonics may be analyzed by a resonator which suppresses all but one of these harmonics.

3. Another Explanation.— The phenomenon may be explained in a different manner. The vibrations produced by an oscillator decay very rapidly; the energy of the

oscillation is quickly transformed into heat by the resistance of the spark-gap, or dissipated by radiation into space.

What is the result? We have shown above how the reflected wave is added to or subtracted from the direct wave, and that it is this composition of the two impulses which produces stationary waves. But consider a point, A, at some distance from the end of the wire. (Fig. 40.) A considerable time is required for the impulse to travel from A to the end of the wire and return after reflection to A; and during this time, the damping of the direct wave may have completely extinguished it. Thus, on the arrival of the reflected wave

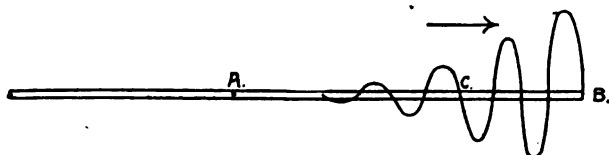

FIG. 40.—A strongly damped wave-train about to be reflected from the free end B of a wire. Interference between the direct and reflected waves can occur only within the space BC, equal to half the length of the wave-train.

at A there is no direct wave for it to combine with, and hence no stationary waves can be formed.

Thus we see that *there are no stationary waves, properly speaking, except near the end of the wire.*

Yet, *by using a resonator* we may observe a succession of nodes and loops throughout the whole length of the wire. How can this be?

The paradox is readily explained on the assumption that the vibrations of the oscillator are damped much more rapidly than those of the resonator. When the direct wave passes it sets the resonator in vibration; when the reflected wave returns, the direct wave has been extinguished in the wire, but the resonator has not ceased to vibrate. It receives a

second impulse from the reflected wave. Will this impulse increase the amplitude of its oscillations or diminish them?

Consider an analogy.

A pendulum receives a first impulse which causes it to move, say from left to right. After a half oscillation it will be moving from right to left; after a complete oscillation it will again be moving from left to right. In general, after a whole number of oscillations it will move from left to right; after an odd number of half oscillations, it will move from right to left.

Suppose it to receive a second impulse in the same sense as the first. If this impulse be given after a whole number of oscillations, when the pendulum is moving from left to right, it will tend to increase the velocity; if the impulse come after an odd number of half oscillations, when the pendulum is moving from right to left, it will tend to diminish it.

So with the resonator: this apparatus receives a first impulse on the passage of the direct wave; a second, on the passage of the reflected wave. If, between these two impulses, the resonator perform a whole number of oscillations — that is, if the difference between the distances traveled by the two waves be equal to a whole number of wave-lengths *of the resonator* — the effects of the two impulses will be cumulative, and a loop will be observed. If, on the other hand, the difference between the distances traveled be equal to an odd number of half wave-lengths of the resonator, the effects of the two impulses will annul each other, and a node will be observed.

Thus, the distance between two nodes should be equal to the half wave-length of the resonator; the wave-length of the oscillator does not enter the result.

A few remarks in passing regarding this second explanation:

We have seen what occurs when the two impulses received by a pendulum are in the same sense: the effect is reversed when they are in opposite senses. Now, it is evident that the impulse due to the direct wave and that due to the reflected wave may be in the same sense or in opposite senses, according to the manner in which the reflection is produced (see page 61) and according to the position of the resonator. Hence we have an exceedingly simple explanation of the experiments of M. Turpain, which have seemed paradoxical to some persons, but which are sufficiently accounted for by symmetry.

In the second place, we may ask why an apparatus consisting in two long wires is not equivalent to a large resonator, but responds indifferently to excitations of all periods. If it were not for damping, the reflected waves, interfering as has been explained on page 39, would produce resonance effects. But this is not the case: when one of the reflected waves reaches a given point of the wire, the direct wave has long been extinguished, and there is no interference.

4. Experiments of Garbasso and Zehnder.— Between the two explanations proposed above, experiment alone can decide.

Zehnder attempted to observe directly the continuous spectrum postulated in the theory of MM. Sarasin and de la Rive. He employed a sort of grating which should separate the different components of a complex wave emitted by the oscillator, just as the ordinary grating used in optics separates the different colors which constitute white light.

Garbasso endeavored, by means of a complicated apparatus which we cannot describe here, to imitate the dispersion produced by a prism when acting on white light.

These experimenters obtained the results which they expected, thus apparently confirming the explanation of Sarasin and de la Rive.

The experiments seem conclusive, but they are not. Indeed, it may be shown by a simple calculation that a damped vibration has the characteristics of a complex vibration giving a continuous spectrum in which *the intensities are distributed according to a particular law.*

Hence it is not sufficient to prove that the vibration emitted by an oscillator behaves as if it had a continuous spectrum;

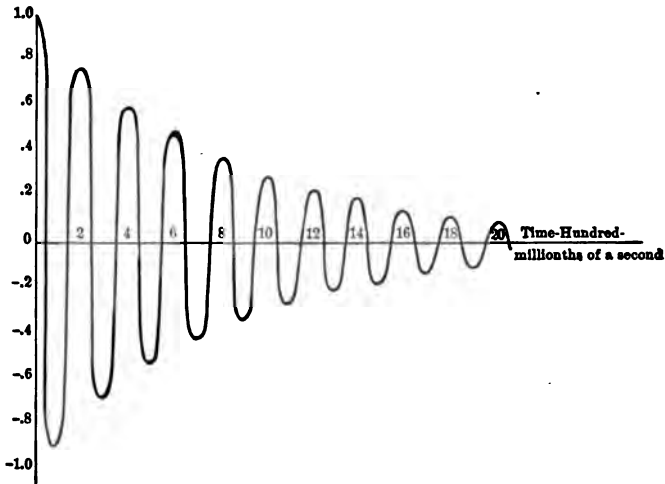

FIG. 41.—A strongly damped oscillation, such as is produced by a dumb-bell oscillator. The logarithmic decrement = .26.

it must also be shown that, in this spectrum, the intensities of the various components do not vary according to that particular law.

5. Measurement of the Decrement.—Quite on the contrary, a series of experiments which we shall now consider have shown, not only that the intensities do vary according to this law, but that the second explanation is the true one.

It was first necessary to prove the fundamental hypothesis on which this second explanation rests — to be certain that the damping of the oscillator is much more rapid than that of the resonator.

We have seen (page 45) how Herr Bjerknes measured the decrement of a resonator.

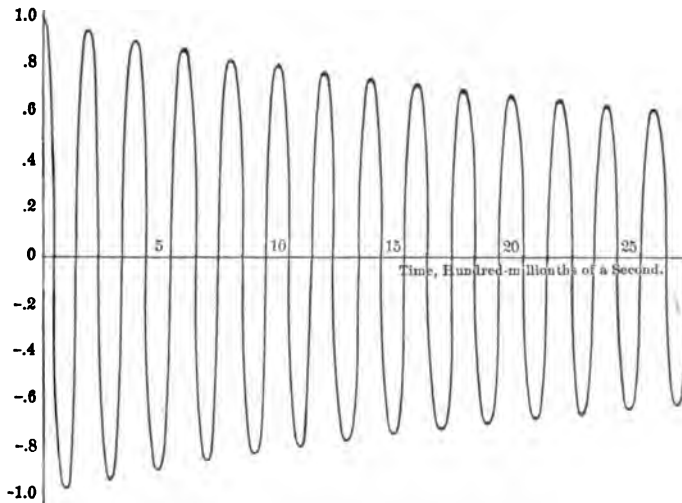

FIG. 42.— A feebly damped oscillation, such as that of a resonator with a logarithmic decrement of .034. The waves which excited the resonator are here supposed to have subsided, and the oscillations are undergoing their normal decay.

For an oscillator he found a “logarithmic decrement”* of 0.26, while he obtained, for two resonators, 0.002 and 0.034.

* The term “logarithmic decrement,” as used by Bjerknes, denotes the natural logarithm of the ratio of two adjacent maxima — separated by a *complete period*. This differs from the ordinary definition of Kohlrausch and others, which involves the ratio of two consecutive turning points — separated by a *half period* — and which gives values of the logarithmic decrement half as great as the above.— F. K. V.

That is to say, to reduce the amplitude of the oscillations to one-tenth of its initial value, nine oscillations were sufficient in the case of the oscillator, while the two resonators required, respectively, more than 60 and more than 1,000. (See Figs. 41 and 42.)

Thus the vibration of an oscillator is damped much more rapidly than that of a resonator.

6. Experiments of Strindberg.— To complete the proof it was necessary to show that if, by any artifice, the damping of the resonator could be made greater than that of the oscillator, the phenomena would be reversed; that is, the internode would depend no longer upon the resonator, but on the oscillator.

This was done independently by M. Décombe in France, and M. Nils Strindberg in Sweden.

I cannot write this name without reminding the reader that M. Strindberg, not content with serving science by his intelligence, would also contribute his courage. He accompanied M. Andrée on his perilous æronautic journey in the polar regions.

To accomplish the desired result it was necessary to diminish the damping of the oscillator and increase that of the resonator.

To diminish the decrement of the oscillator it was first necessary to stop the loss of energy in the spark. This seems at first impracticable, for, without an interrupter, the release of the "electric pendulum" is impossible and its oscillations cannot be started. But M. Strindberg met the difficulty by a simple artifice. A primary oscillator was provided with a spark-gap. It acted by induction upon a secondary oscillator which was entirely similar to the first, but, being set in vibration by the action of the primary, did not require an interrupter. This secondary oscillator had the

same period as the primary, but a smaller decrement, and it was used to produce the disturbance in the wires by means of the arrangement of M. Blondlot. (See page 49, Fig. 35.)

Again, it was easy to increase the resistance of the resonator; and, as the resistance is a sort of friction, this had the effect of increasing the damping of the oscillations.

7. Experiments of Pérot and Jones.— There are other more direct methods of proof. We have seen that, notwithstanding the damping, true stationary waves are formed; but only near the end of the wire. The study of these stationary waves enables us to determine the form of the disturbance produced by the oscillator. But this study, to be successful, must be carried on without the aid of a resonator; for we have seen that resonators produce secondary effects which persist far from the end of the wire, and are then interpreted as the phenomenon of "multiple resonance." These disturbing effects must be suppressed.

The various methods described on pages 42–44, which are independent of the resonator, have been used to this end.

M. Pérot used the spark without a resonator.

Mr. Jones employed a thermal method, based on the use of a thermo-pile.

Herr Bjerknes used a mechanical method.

All these experiments confirmed the second explanation.

8. Experiments of Décombe.— Even these methods did not seem sufficiently direct to M. Décombe. He wished to study the disturbance at the moment it was produced by the oscillator; indeed, we may well inquire if the oscillation is not changed in passing from the oscillator to the wires, or in traveling along the wires.

To this end M. Décombe undertook to photograph the spark of the oscillator by means of a rotating mirror. This had been done by Feddersen (cf. Chapter III), but with oscilla-

tions of much lower frequency. With Hertzian oscillations the difficulties were much greater; indeed, they would have been insurmountable with the apparatus used by Hertz himself (50,000,000 vibrations per second). M. Décombe had to be content with an oscillator giving 5,000,000 vibrations, whereas the apparatus of Feddersen gave only 20,000 to 400,000.

The different sparks which correspond to the successive oscillations produce, on the sensitive plate, an image consisting in separate points, because of the motion of the mirror. The motion must be sufficiently rapid to keep these points distinct and separate from one another. M. Décombe's mirror, made 500 revolutions per second.

In order that the plate might receive an impression, notwithstanding the extreme brevity of the exposure, M. Décombe found it necessary to carry to the extreme every means at his disposal, and to put all the chances in his favor.

He had to use an oscillator with a small decrement, to produce the spark under oil, where it is smaller and more brilliant, and to use a particularly energetic developing solution. The optical apparatus was so arranged that the luminous spots would be very small and very intense.

All the details of this experiment reflect the greatest credit upon their author. Success rewarded his efforts, and he obtained images whose study reveals the existence of a simple damped oscillation, in conformity with the second explanation.

The oscillator, it is true, is not that of Hertz, and its oscillations have only one-tenth the frequency of his, but the difference is sufficiently small to justify us in reasoning from one to the other.

CHAPTER VIII.

PROPAGATION IN AIR.

1. **The Experimentum Crucis.**—All the experiments which we have thus far considered are incapable of deciding between the old theory and that of Maxwell.

Both theories agree that electrical disturbances should be propagated along a conducting wire with a velocity equal to that of light. Both take account of the oscillatory character of the discharge of a Leyden jar, and consequently of the oscillations produced by a Hertzian oscillator. Both assert that these oscillations should produce electro-motive forces of induction in the surrounding medium, and hence should excite a resonator placed in the vicinity.

But *according to the old theory, the propagation of inductive effects should be instantaneous.* If, indeed, there be no displacement currents, and consequently *nothing*, electrically speaking, in the dielectric which separates the inducing circuit from that in which the effects are induced, it must be admitted that the induced effect in the secondary circuit takes place at the same instant as the inducing cause in the primary; otherwise in the interval, if there were one, the cause would have ceased in the primary circuit, while the effect is not yet produced in the secondary; and, as there is nothing in the dielectric which separates the two circuits, there is nothing anywhere. Thus the instantaneous propagation of induction is a conclusion which the old theory cannot escape.

According to Maxwell's theory, induction should be propagated in air with the same velocity as in a wire; that is, with the velocity of light.

Here, then, is the *experimentum crucis*: we must determine with what velocity electromagnetic disturbances are propagated by induction through the air. If this velocity be infinite, we must adhere to the old theory; if it be equal to the velocity of light, we must accept the theory of Maxwell.

How, then, can this velocity be measured? We cannot measure it directly; but we have seen that the wave-length is, by definition, the distance traveled in the time of one vibra-

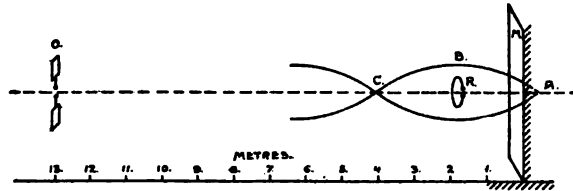

FIG. 43.—Hertz's apparatus for observing stationary waves in air. O is the oscillator, M a plane mirror of zinc fastened against a stone wall, and R a closed resonator. When the resonator is moved from the mirror towards the oscillator the spark-length varies in the manner indicated by the curve. Only two nodes, A and C, are observed, owing to the damping of the waves. As the mirror is not a perfect conductor, the node A is apparently behind the surface.

The figure is drawn approximately to scale.

tion; and we have also seen how the wave-length in a wire may be measured.

If the wave-length in air is the same as that in a wire, then the velocity of propagation in air is the same as the velocity along a wire, and the theory of Maxwell is true.

The problem is thus reduced to the measurement of the wave-length in air.

In making this measurement the same method may be used as in the case of propagation along a wire.

We have seen that the direct wave transmitted along the wire was caused to interfere with the wave reflected at the end of the wire. In like manner, the direct wave transmitted through the air may be made to interfere with the wave re-

flected from a plane metallic mirror. This mirror should be so placed that the direct wave will strike it normally, and consequently, the reflected wave will travel in the opposite direction to that of the direct wave. (See Fig. 43.)

Under these conditions we should obtain true stationary waves if the vibrations of the oscillator were not damped; but, because of this damping, and for the same reasons as were developed in Chapter VII, the phenomenon of multiple resonance will occur. It is needless to repeat the discussion given on pages 61-64: the phenomena in this case are exactly similar.

If a resonator be moved between the oscillator and the mirror, a series of nodes and loops will be observed; the nodes are the points where the resonator fails to respond to the oscillator, the loops are those where the intensity of the phenomenon is a maximum.

The internode, or distance between two nodes, is equal to the half wave-length of the vibration *of the resonator* in air; just as in the case of propagation along a wire, the internode was equal to the half wave-length of the vibration of the resonator when traveling along a wire. If, then, the internode in air is the same as along a wire, the wave-length in air is equal to that in a wire, and Maxwell's theory is true.

2. Experiments at Karlsruhe.— This is the *experimentum crucis* which Hertz first performed at Karlsruhe. He did not at once obtain the expected result.

Along a wire his resonator gave an internode of 3 meters; in air it seemed to show an internode of 4.50 meters, or 9 meters wave-length. This experiment seemed undeniably to condemn the old electrodynamic theory, which demanded an infinite wave-length; but it seemed none the less to condemn the theory of Maxwell, which involved a wave-length of 6 meters.

This failure is still unsatisfactorily explained. It is probable that the mirror was too small with respect to the wave-length, and that diffraction entered to disturb the phenomena. Perhaps also, the reflection of the waves from the walls of the room or from the cast-iron columns which divided the room into three sections, may have exercised a disturbing influence.

However this may be, the smallest oscillators gave a different result, and showed the same internode in air as in a wire; doubtless the smaller wave-length was not too great with respect to the dimensions of the mirror.

3. Experiments at Geneva.— Still, the question was not settled, and illness prevented Hertz from continuing his experiments. MM. Sarasin and de la Rive took them up with sufficient precautions to eliminate all sources of error.

Their mirror was 8×16 meters, and they worked in a very large and unencumbered room. The results were as clear with the 75 centimeter resonator (having the same wave-length as Hertz's large oscillator) as with the smaller ones. These experiments must thus be regarded as conclusive.

In conformity with Maxwell's theory, the internode was the same in air as in a wire.

4. Use of the Small Oscillator.— The experiment may be more easily repeated with the small oscillator of Hertz, which, we have seen (page 35), consists in a short rod of metal divided in the middle.

Parabolic mirrors are in common use for gathering the light emanating from a small source into a beam of parallel rays. Such an apparatus is called a parabolic projector or reflector.

The radiations produced by an oscillator may be treated in almost the same way; only the dimensions of the oscillator are comparable to those of the mirror, so that the former is more like a luminous line than a luminous point.

Hence, instead of giving the mirror the form of a paraboloid of revolution with the source of the radiations at its focus, it is made in the form of a parabolic cylinder and the oscillator is placed in its focal line. (Fig. 44.) Thus a parallel beam of electrical radiations is obtained.

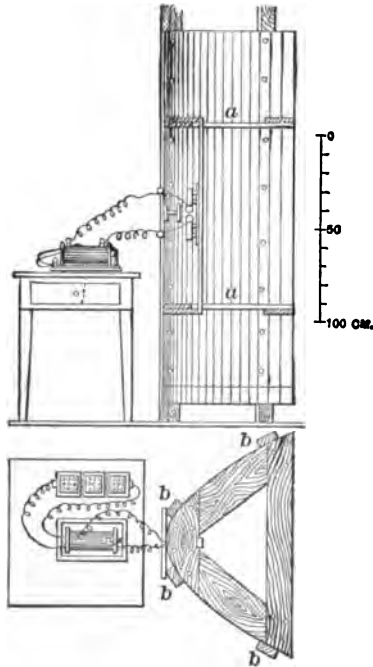

FIG. 44.—Hertz's apparatus for concentrating the radiations of an oscillator by means of a parabolic mirror of zinc. (From "Electric Waves," Eng. Trans.)

In like manner the resonator, which is just like the oscillator, may be placed in the focal line of a second parabolic mirror. This mirror concentrates the parallel rays upon the resonator.

However, in the interference experiments just described, the second mirror should not be used, for it would act as a screen to shield the resonator from the reflected wave.

5. Nature of the Radiations.—The field which surrounds an oscillator is traversed by electromagnetic radiations: the theory enables us to formulate the laws of their distribution, and these have been further confirmed by experiment, at least in their general characteristics, which are all that our present means of investigation enable us to determine.

These laws are rather complex, and, in order to simplify their exposition, we shall consider only those points of the field which are a long distance from the oscillator.

Imagine a sphere of very large radius, having its center at the middle of the oscillator. At each point of this sphere there is a variable electromotive force, which passes through zero and changes sign twice during each oscillation but does not change its direction. There is also a magnetic force which varies in a similar manner.

What is the direction of these two vibrations — the one electric, the other magnetic?

Trace on the sphere a system of meridians and parallels, as on a terrestrial globe; the poles being at the points where the sphere is cut by the axis of the oscillator produced. The electric force at any point will be tangent to the meridian; the magnetic force, to the parallel. (Fig. 45.)

The two vibrations are thus at right angles to each other, and both are perpendicular to the radius of the sphere — that is, to the direction of propagation, corresponding to what is, in optics, the direction of the ray of light. *These two vibrations are thus transverse, like those of light.*

The amplitude of these vibrations varies inversely as the distance from the oscillator, hence the intensity varies inversely as the square of the distance.

The vibration maintains, as we have seen, a constant direction; hence it is comparable to the vibrations of polarized light, rather than those of ordinary light, which constantly change their direction while remaining perpendicular to the path of the ray.

Another question presents itself: What is it that corresponds to the plane of polarization in optics? Is it the plane

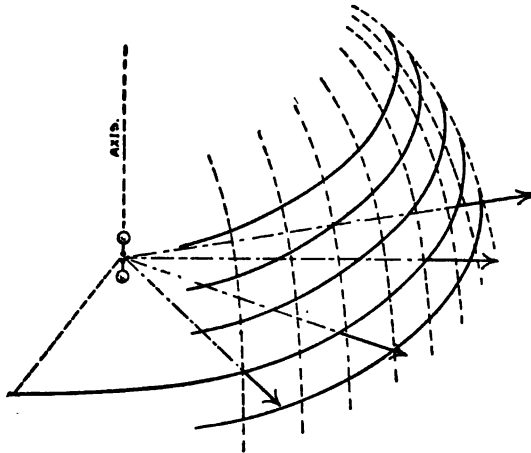

FIG. 45.—A portion of the spherical wave-front proceeding from an oscillator. The full lines indicate the magnetic force, the broken lines, the electric force. The direction of propagation is perpendicular to both of these, and is therefore radial.

perpendicular to the electrical vibration? Or is it the plane perpendicular to the magnetic vibration? We shall see in Chapter XI how it may be shown that the former of these hypotheses is correct.

Another difference from the radiations emitted by a source of ordinary light: the intensity is not the same in all directions. It is a maximum at the equator and zero at the poles

(returning to the network of meridians and parallels which we supposed to be traced on our sphere).

Aside from these differences, the mode of propagation of an electromagnetic disturbance through air is the same as that of light. In the case of propagation along a wire, also, we had displacement currents; but these were sensible only

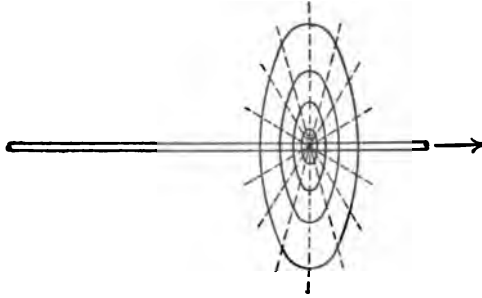

FIG. 46.— A portion of the wave-front surrounding a perfectly conducting wire transmitting oscillations. The magnetic force forms closed circles concentric with the wire, which slide along without expanding; hence the intensity of the wave remains constant. The electric force, and hence the displacement currents, are radial, and so are strongest close to the wire.

in the air in the immediate neighborhood of the wire. Instead of spreading out in all directions, the disturbance was propagated along a single line; consequently its intensity was maintained, instead of diminishing according to the law of inverse squares. (Fig. 46.)

CHAPTER IX.

PROPAGATION IN DIELECTRICS.

1. **Maxwell's Relation.**— When, in a condenser, we replace the layer of insulating air by a layer of some other insulating substance, we find that the capacity of the condenser is multiplied by a coefficient which is called the “specific inductive capacity” of this substance. The theory demands that the velocity of propagation of electric waves in a dielectric be inversely proportional to the square root of the specific inductive capacity of the dielectric.

Again, the velocity of light in a transparent medium is inversely proportional to the index of refraction. Hence the specific inductive capacity should be equal to the square of this index. This is the theoretical relation of Maxwell.

It is poorly verified, except for sulphur. This may be explained in two ways:— either the index of refraction for very long waves, such as electrical oscillations, is not the same as the optical index of refraction — which would not be at all surprising, since we know that different radiations are unequally refrangible, and that the index for red is different from the index for violet —; or the square of the electrical index of refraction may itself be different from the specific inductive capacity as measured by static methods in an invariable field — which could be explained by various secondary effects, such as residual charges.

Hence the necessity of measuring the specific inductive capacity by two sorts of methods: the dynamic methods, based on the use of electrical oscillations, which will give the electrical index of refraction; and the static methods, in a constant field.

2. Dynamic Methods.—The velocity of propagation is the same in air or along a metallic wire stretched in the air. So also, the velocity of propagation through a dielectric should be the same as the velocity along a wire immersed in the dielectric. Hence it is sufficient to measure the latter.

We have seen how the wave-length of an electrical oscillation may be determined by measuring the distance between the nodes on a wire, by means of a resonator (see page 59). If the wire be immersed in a dielectric, the velocity of propagation is diminished: as the period remains the same, the wave-length and the distance between the nodes are diminished in the same ratio. Thus we may simply measure this ratio, which is the reciprocal of the electrical index of refraction.

Suppose again that the resonator used for exploration be made of a condenser whose plates are joined by a wire (Blondlot's resonator). If a layer of insulating material be placed between the plates, the capacity of the condenser is multiplied by the specific inductive capacity; the period of vibration to which the resonator responds is thus increased, and, consequently, also the distance between the nodes.

If the wire along which the electrical oscillations are propagated, and the resonator with its condenser, be immersed in the same dielectric, the two effects should exactly balance each other, and the distance between the nodes should be unchanged. This is found to be the case.

These methods of measuring the electrical refractive index are analogous to the interference refractometer in optics. We may also make use of the refraction of the electric rays by a prism of the dielectric; or, better still, of total reflection.

3. Static Methods.—To measure an inductive capacity in a constant field we must compare two capacities. This may be done:

First. By discharging a condenser through a *ballistic galvanometer*, which measures the quantity of electricity which flows;

Second. By charging and discharging a condenser a great number of times per second, and comparing the intermittent current thus produced with a continuous current through a given resistance (*Maxwell's method*);

Third. By connecting two condensers in series, and proving the equality of their capacities by showing that the potential of the middle plates is the arithmetical mean of the potentials of the terminal plates (*Gordon's method*);

Fourth. By measuring the *attraction* between two electrified spheres immersed in the dielectric;

Fifth. By connecting in opposition two electrometers whose needles and whose corresponding pairs of quadrants are respectively in metallic connection, and which are immersed, one in a dielectric, the other in air (*Differential electrometer*);

Sixth. By studying the deviation of the lines of force in an electrostatic field occasioned by the introduction of a prism of dielectric material (*Pérot's method of equipotential surfaces*).

4. Results.— These different methods give very discordant results. For resin, the following values have been obtained for the specific inductive capacity, which we shall call ϵ :

Square of the optical index.....	2.0
By equipotential surfaces	2.1
With Hertzian oscillations	2.12
By ballistic galvanometer	2.03
By another static method	2.88
By the method of attraction.....	5.44

For alcohol, water, and ice we find still greater discrepancies.

Alcohol.—*a.* The static methods gave for $\sqrt{\epsilon}$ values in the neighborhood of 4.9, that is, quite different from the optical index;

b. Yet, Stehettiæf, using Gordon's method with oscillations produced by a Ruhmkorff coil, found for $\sqrt{\epsilon}$ a value not far from the optical index.

c. Methods founded on the use of Hertzian oscillations gave a value in the neighborhood of 4.9.

Water.—*a.* M. Gouy, by a method of attraction, found:
 $\epsilon = 80.$

The value of ϵ varies, of course, with the impurities in the water, which render it more or less conducting; 80 is the value which ϵ approaches as the conductivity of the water approaches zero.

b. Herr Cohn measured ϵ by determining the wave-length in a wire immersed in water. He found that ϵ depends upon the conductivity of the water and on the temperature. His values are near to that of M. Gouy.

c. Only one experimenter has found for ϵ a value approaching the square of the optical index, $\epsilon = 1.75.$

Ice.— A static method gave
 $\epsilon = 78,$

a value close to that obtained by M. Gouy for water.

M. Blondlot, on the other hand, found, by the use of Hertzian oscillations

$$\epsilon = 2.5$$

and M. Pérot, by the same method, obtained a similar value.

Thus we find an enormous difference between the values of MM. Blondlot and Pérot, on the one hand, and the number 78, on the other.

5. Conducting Bodies.— Substances transparent to light are, in general, bad conductors; the metals, on the contrary, are very good conductors and very opaque. There is noth-

ing paradoxical about this. The dielectrics offer to electric waves an elastic reaction (see Chapter II) which returns the energy imparted to them; hence they permit the oscillations to pass. Conductors, on the other hand, offer a viscous resistance which destroys the kinetic energy to convert it into heat; hence they absorb electric waves and light.

Indeed, it is found that the metals stop electrical waves like a screen; they make an imperfect screen for oscillations of very long period, but their opacity is almost absolute for Hertzian waves. The experiments of Herr Bjerknes, cited above (page 50), show that these radiations cannot penetrate a metal to a depth greater than a hundredth of a millimeter.

Nevertheless, Professor Bose, whose very sensitive apparatus will be described later, apparently observed the penetration of metals by his radiations; but M. Branly has recently shown that a metallic envelope is impenetrable, even to the very rapid oscillations obtained by Professor Bose, *provided that the envelope is absolutely closed*. Even the smallest opening invites diffraction sufficient to affect the very sensitive detector of Professor Bose.

6. Electrolytes.— Thus all conducting bodies are opaque; all insulators are transparent. This rule admits of apparent exceptions.

Certain substances, like ebonite, are insulators without being transparent. But it is found that, although opaque to visible light, they transmit Hertzian radiations.

There is no more reason for surprise at this than at the passage of red light through a red glass which will not transmit green light. Besides, these substances, which are transparent to electrical waves of long period, would naturally act as dielectrics in a static field, where the period may be regarded as infinite.

On the other hand, certain liquids, like salt or acidulated water, are conductors of electricity but transparent to light. This is because such liquids, which are decomposed by a current and are called electrolytes, have a conductivity of a very different nature from that of metals.

The molecules of the electrolyte are decomposed into "ions," and the electricity is *transported* from one electrode to the other by these ions, which travel through the liquid. Hence the electrical energy is not transformed into heat, as in the case of metals, but into chemical energy. Doubtless this process, which depends upon the comparatively slow movement of the ions, has not time to take place if the vibrations are as rapid as those of light. In fact, the electrolytes are somewhat transparent even to Hertzian waves.

CHAPTER X.

PRODUCTION OF VERY RAPID OSCILLATIONS.

1. **Very Short Waves.**—Blondlot's oscillator gives a wavelength of 30 meters, the large oscillator of Hertz a wavelength of 6 meters, and the small oscillator of Hertz, 60 centimeters. In other words, we have:

	Vibrations per second.
With the oscillator of Blondlot.....	10,000,000
With the large oscillator of Hertz.....	50,000,000
With the small oscillator of Hertz.....	500,000,000

But this is not the limit. The learned Italian physicist, Sig. Righi, and after him, the young Hindoo professor, Sagadis Chunder Bose, constructed apparatus which enabled them to go much farther.

Theoretically it was only necessary to decrease the size of the apparatus; but this also diminished the intensity of the oscillations, and extremely sensitive detectors had to be devised to observe them.

2. **Righi's Oscillator.**—This oscillator consists in two spheres of brass, A and B (Fig. 47), fixed in the centers of two discs of wood, glass, or ebonite. These discs form the

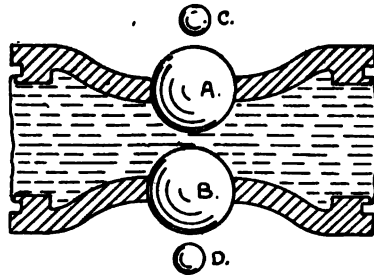

FIG. 47.—Righi's oscillator. This is similar to Lodge's (FIG. 24), but the balls are smaller and the spark occurs in a vessel of oil. The waves emitted are thus very short, but not correspondingly feeble.

bottom and top of a cylindrical vessel with flexible sides, whose diameter is much greater than its height. In one of the discs is a small hole for filling the vessel with vaseline oil. The flexibility of the side walls of the vessel permits the use of various arrangements for regulating the distance between the spheres.

The spark leaps between the two spheres, as in Lodge's oscillator; but, owing to the small dimensions of the spheres, the wave-length is very small.

We have seen above the advantages of having the spark occur in oil. It is through this artifice that the oscillations retain sufficient intensity, notwithstanding the smallness of the apparatus; for we have seen that the use of oil strengthens the oscillations, while improving the regularity of the sparks.

For charging the oscillator, Righi used, not an induction coil, but a Holtz statical machine. This has also been used with Hertz's oscillators.

It is important to note that the spheres A and B are not connected directly to the two poles of the Holtz machine,—these poles are connected metallically to two other spheres, C and D; the sphere C being placed at a short distance from A, the sphere D close to B. Thus three sparks are produced; the first between C and A, the second between A and B, and the third between B and D. The first and last occur in air, and the second in oil.

It is the second spark that has the oscillatory character. The two others, which take place in air, serve only to charge the two spheres A and B. When these have received sufficient charges, the spark A B breaks through the oil and the oscillations commence.

It is important to properly adjust the lengths of the three sparks: Righi gave the middle spark a length of about one

millimeter, and the others two centimeters. The diameter of the spheres A and B was about four centimeters. The wavelength was about ten centimeters, hence the frequency was 3,000,000,000 vibrations per second.

With spheres of eight millimeters diameter Sig. Righi obtained oscillations four times as rapid.

3. Resonators.— Notwithstanding the improvements introduced by Righi in the construction of his oscillator, its effects are still very feeble, and especially sensitive resonators are required to detect them.

Two principles guided the learned Italian in designing his resonator: first, the sparks are much longer, for a given difference of potential, when they play across the surface of an insulating body than when they leap through free air; and second, as the electromagnetic effects are propagated only on the surface of a metal, the thickness of the metallic parts of a resonator may be reduced without detriment.

Righi deposited electrolytically, on a plate of glass, a thin film of silver in the form of a rectangle much longer than wide. Across the middle of the rectangle the silver film is cut through by a diamond, leaving a gap a few thousandths of a millimeter wide. It is across this gap that the sparks play. They respond to very small differences of potential, since the space to be bridged is so narrow and the sparks pass across the surface of the glass.

The sparks are observed by means of a small microscope.

This resonator operates in the same manner as the rectilinear resonators of Hertz. The rays of electrical force emanating from the oscillator are rendered parallel by a mirror in the form of a parabolic cylinder, and another similar mirror concentrates them on the resonator.

This very sensitive apparatus is well adapted to measurement. If the resonator be rotated, the action becomes a maxi-

imum when the resonator is parallel to the oscillator, that is, to the line joining the centers of the two spheres, A and B; it is zero when the resonator is perpendicular to the oscillator,

and in other positions it takes intermediate values. Thus, the position of the resonator when sparks began to appear affords an indication of the intensity of the radiations.

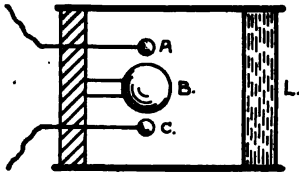

FIG. 48.—Bose's oscillator (nearly full size). The platinum sphere B, which is insulated, is the seat of the oscillations. The spheres A and C are connected to the induction-coil. L is a cylindrical lens for concentrating the radiation.

4. Bose's Oscillator.—Prof. Jagadis Chunder Bose has obtained still more rapid oscillations. His oscillator consists in three metallic spheres, A, B and C (Fig. 48); the two spheres A and C connected to the poles of a Ruhmkorff coil, the middle sphere, B, insulated. Sparks leap between A and B, and between B and C. This is another form of Lodge's oscillator.

The sparks occur in air; still, the electrodes must not be allowed to deteriorate if the discharge is to retain its oscillatory character. To this end, Professor Bose uses spheres of platinum instead of brass, and, instead of operating his coil with a vibrating interrupter, he uses a hand break. Each motion of the hand gives him a single series of decreasing oscillations, in place of an uninterrupted stream of sparks which would rapidly destroy the electrodes.

With these precautions, the discharges continue to be oscillatory without the necessity of frequent cleaning and polishing of the balls.

The radiations are feeble, but Professor Bose depends for his results on the sensitiveness of his detector. He finds the intensity of the action less important than its regularity and constancy, without which measurements would be impossible;

indeed, in his estimation, very strong oscillations would be detrimental, for reflection and diffraction might produce secondary radiations capable of affecting the detector and disturbing the observations.

The coil and battery are inclosed in a double metallic case, almost entirely closed, so that they can exert no disturbing influence on the exterior. The tube containing the oscillator is mounted on the box, and the radiations are rendered parallel by a cylindrical lens of sulphur or ebonite.

This apparatus gives a wave-length of six millimeters, which corresponds to 50,000,000,000 vibrations per second. Vibrations 10,000 times as rapid would suffice to impress the retina (they would correspond to the orange rays of the spectrum); thus, says Professor Bose, we are within thirteen octaves of visible light. It has been found possible to produce a pencil of parallel electric rays with a cross-section of one or two square centimeters.

5. Bose's Detector.—The detector is based on the principle of the Branly coherer, or radio-conductor. The coherer is an instrument of marvelous sensitiveness, but it is somewhat capricious in its action. At times it becomes so extraordinarily sensitive that the galvanometer is deflected without any apparent cause; and again, when it seems to be working admirably, its sensitiveness suddenly disappears. Perhaps some of the particles come into too intimate contact; or again, the contact surfaces lose their sensitiveness through fatigue due to prolonged activity.

Professor Bose modified the original coherer to overcome these defects. Pieces of fine steel wire were wound into spirals, which were placed side by side in a narrow groove in a block of ebonite, each tiny spiral touching its neighbor in a well-defined contact. At each end of the groove were pieces of brass, one fixed and the other capable of sliding, and both

connected to the terminals of a battery. A screw regulated the pressure of the movable block upon the first spiral, and this pressure was transmitted from spiral to spiral, so that it was uniform over all the contacts.

The current from the battery entered at the upper spiral, and, passing from one to the other through the contacts between them, left through the lower spiral.

When electromagnetic radiations impinge upon the apparatus, the resistance offered by the series of contacts is diminished, the current traversing them from the battery is increased, and the variation is shown by a galvanometer.

As all the points of contact lie in the same straight line, the radiations may be concentrated upon them by means of a cylindrical lens.

The sensitiveness of this apparatus is exquisite, and it responds to all radiations over the range of an octave. It may be made sensitive to radiations of different kinds by varying the electromotive force of the battery which operates it.

The apparatus is inclosed in a metallic case with no opening but a narrow slit. It is thus protected from all radiations except those which are concentrated on this slit.

CHAPTER XI.

IMITATION OF OPTICAL PHENOMENA.

1. Conditions of Imitation.—According to Maxwell's ideas, light is nothing more nor less than an electromagnetic disturbance propagated through air, space, or other transparent medium. The electrical radiations emanating from an oscillator differ from light only in their period, and it is simply because their wave-length is too great that they do not impress the retina.

We have seen that these disturbances travel at exactly the same velocity as light, but this is not sufficient; it must be shown that they possess all the properties of light, and that we can reproduce with them all optical phenomena.

The great length of the waves is, however, a serious obstacle; to reproduce the conditions under which optical phenomena are observed, all dimensions must be increased in proportion to the wave-length, according to the law of similarity.

If we are using, for example, the large oscillator of Hertz (wave-length six meters), a mirror, to bear the same relation to its radiations as a mirror one millimeter square bears to light, would have to be ten kilometers square. Even with Bose's little oscillator, we should need a mirror ten meters square.

It is evident that this condition can be only imperfectly fulfilled, but the approximation will be closer as we use shorter waves. Hertz obtained fairly good results with his small oscillator; but, as might be expected, Righi and Bose, who used waves only one-tenth and one-hundredth as long, achieved a much more perfect imitation.

2. Interference.— We considered in Chapter VIII the interference produced between the electric waves proceeding directly from an oscillator and those reflected by a metallic mirror. In these experiments the two interfering rays — the direct ray and the reflected ray — were traveling in opposite directions. (Fig. 49.)

Here the conditions are very different from those which obtain in optical apparatus designed for the study of interference, where the two rays travel in the same sense and intersect at a very acute angle. The more acute this angle, the

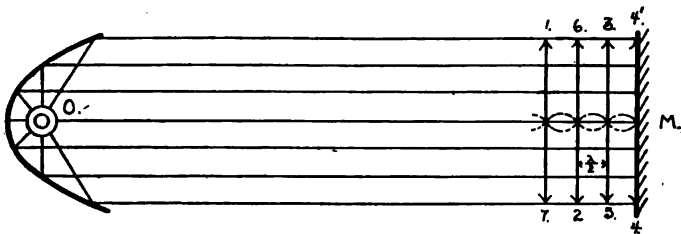

FIG. 49.— Interference by reflection from a single mirror, *M*. 1, 2, 3, etc., represent wave fronts differing in phase by a half period, 1 to 4 being direct and 4' to 1' reflected and reversed in sign. The planes in which two opposite wave fronts, 4-4', 3-3', 2-2', etc., meet are interference striæ, separated by a half wave-length, $\frac{\lambda}{2}$.

wider are the interference fringes, and hence the easier to observe. In optics we do not ordinarily produce interference between rays traveling in opposite senses, for this would give fringes of a few ten-thousandths of a millimeter only.

Not until quite recently did Wiener succeed in observing the optical bands produced under such conditions, though it is this phenomenon that is utilized in M. Lippmann's process of color photography. M. Lippmann places the sensitive plate against a surface of mercury, which acts as a mirror. The direct ray interferes with the ray reflected from the mer-

cury, which travels in the opposite direction, and a series of equidistant striæ are produced in the sensitive film. These striæ are entirely analogous to the electrical striæ considered in Chapter VII.

But Righi achieved a better imitation of the ordinary experiments in interference. He caused the electrical waves to be reflected by two mirrors inclined at a small angle. (Fig.

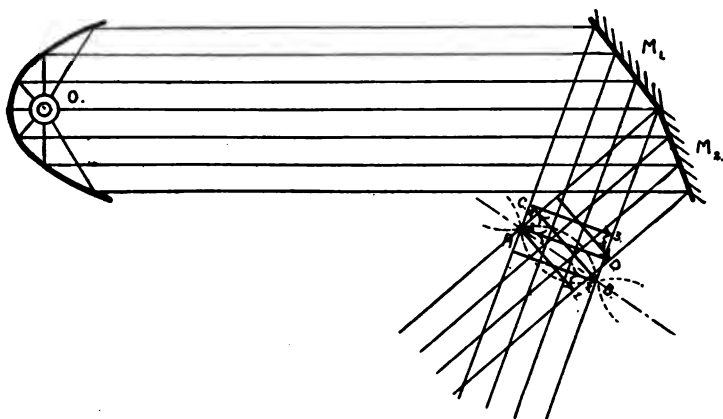

FIG. 50.—Interference between two rays intersecting obliquely (the angle between the mirrors, M_1 , M_2 , greatly exaggerated). Here the opposing wave-fronts, 1-2, 2-3, etc., intersect at A, B, C, D, etc., in planes nearly parallel to the rays, and separated by a distance, A B, depending upon the acuteness of the angle of intersection. A resonator moved in the direction A B would show successive maxima and interference points.

50.) When proper precautions are taken to shield the resonator from the direct ray by means of a metallic screen, the interference of the two reflected rays may be studied. This is Fresnel's experiment of two mirrors.

Again, the two mirrors may be placed in parallel planes a short distance apart (Fig. 51), and we have an imitation of

the interference apparatus used by Michelson for the optical construction of standard centimeters or decimeters.

Finally, in place of two rays reflected by mirrors, we may cause interference between two rays refracted through prisms of sulphur. This is Fresnel's experiment of the biprism.

3. Thin Films.— One of the most brilliant of optical interference phenomena is that of Newton's colored rings, to which soap bubbles owe their rich coloring. It is due to the inter-

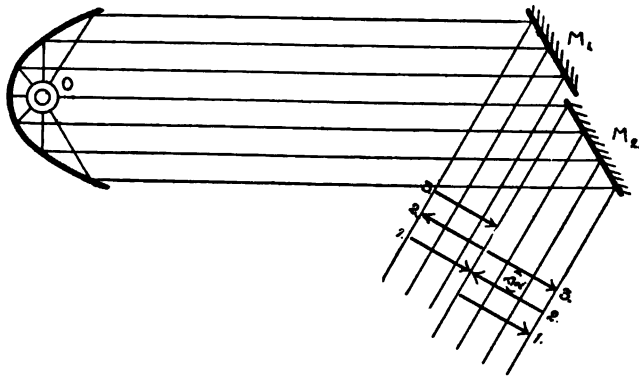

FIG. 51.— Interference between two parallel rays in the same direction. The two reflected rays have the same phase difference at all points, and the degree of interference depends upon the distance between the mirrors M_1 and M_2 .

ference of the rays reflected from the two surfaces of a thin film.

The phenomenon of thin films may be reproduced electrically; but all is relative. In optics, a film, to be thin, must be measured in thousandths of a millimeter; with wavelengths 10,000 to 500,000 times as great, Righi used "thin films" of paraffin, having a thickness of one or two centimeters.

4. Secondary Waves.— A phenomenon which Professor Righi studied in detail is that of secondary waves. The op-

tical analogue is more difficult to observe, and will be discussed in the following chapter.

If a resonator be exposed to the radiations emitted by an oscillator, it enters into vibration, and becomes, in its turn, a source of radiations. These may be detected by a second resonator, shielded from the direct radiations by a metallic screen.

The secondary radiations produced in this way by a resonator may interfere with the direct radiations, and again, secondary radiations produced by two resonators may interfere with each other.

Again, by virtue of the phenomenon of multiple resonance, of which we have already spoken in detail, an oscillator may set in action two resonators of different periods, and these may react upon each other.

Righi has shown that a mass of dielectric becomes, like a metallic resonator, a center from which secondary radiations are emitted.

This is not surprising. How does a resonator respond to its excitation? We have said before, in the same manner as does an organ pipe (cf. page 39). In this pipe, a sonorous wave excited by any cause whatever is reflected at the two ends of the pipe, and so travels to and fro. If there be harmony between the pitch of the tone and the length of the pipe, all these reflected waves will be concordant and cumulative and the sound will be reinforced.

In a metallic resonator, an electrical disturbance is reflected at the two ends of the wire, and the waves thus driven to and fro may combine and reinforce each other in the same way.

If we consider a mass of dielectric, we find a similar state of affairs; the electrical disturbances are reflected from the opposite limiting surfaces of the mass, as, in a resonator, they are reflected by the ends of the wire.

Thus a mass of dielectric is actually a resonator.

All these secondary waves produce, by their mutual interference, a complicated set of phenomena which Professor Righi deserves much credit in unraveling.

5. Diffraction.— The phenomena of diffraction becomes more noticeable as the wave-length is increased, hence it is easy to imitate them with electric waves. All the diffraction



FIG. 52.—A Hertzian wave is plane-polarized, i. e., the vibration takes place always in one plane.

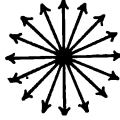

FIG. 53.—In ordinary light the plane of the vibration is constantly changing.

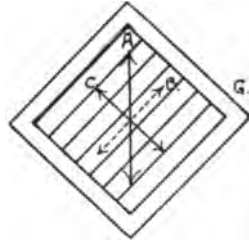

FIG. 54.—Rotation of the plane of polarization of a Hertzian wave, A, by a grid of parallel wires, G, which absorbs the component B, parallel to the wires and transmits the component C, at right angles.

phenomena due to a slit, or to the edge of an indefinite screen, have been reproduced.

But if, for a metallic screen, we substitute a dielectric, the phenomena become more complicated, for we must take into consideration the secondary waves emitted by the dielectric. The application of Huyghens' principle and the purely geometrical theory deduced from it is not always sufficient. It is generally satisfactory in optics, because, on account of the small wave-length, diffraction produces only slight deviations. But even in the experiments of M. Gouy on the am-

plified diffraction produced by the edge of a very keen razor, the geometrical theory is found wanting.

Professor Bose made the imitation of diffraction phenomena complete by constructing actual gratings, and using them for measuring the wave-lengths of his electrical oscillations.

6. Polarization.—Electrical vibrations are always polarized, because they are always parallel to the axis of the oscillator. They are thus analogous to the vibrations of plane polarized light, whose direction is constant (Fig. 52), and not to those of ordinary light, whose direction varies constantly while remaining always in a plane perpendicular to the ray. (Fig. 53.)

We can nevertheless imitate the action of a polarizer which, when traversed by a ray of light already polarized, changes the orientation of the plane of polarization.

For this purpose Hertz used a "grating" or grid composed of a number of parallel wires stretched on a frame. We have seen that a metal interrupts electrical waves simply because it is a conductor. Such a grid is a conductor in only one direction — that of the wires. Hence it will absorb only the vibrations parallel to this direction, and will transmit those perpendicular to it. (Fig. 54.)

It is important not to confound this polarizing grid with the diffraction grating of Professor Bose, which acts like those used in optics. Their functions are entirely different, and the difference is found in the fact that, in the polarizing grid, the distance between the wires is less than the wave-length, while in the diffraction grating it is greater.

The polarizing grid has no optical analogue, though it may be compared to tourmaline, which absorbs vibrations oriented in a certain plane.

7. Polarization by Reflection.—Metals and dielectrics reflect electric waves; their effects should be the same as in the case of metallic and vitreous reflection of polarized light. This has been verified by Trouton and Klemencic. Professor Righi thought at one time he had found the contrary result, but when he recognized the existence of secondary waves, and succeeded in disentangling their laws, he fully confirmed the conclusions of his predecessors.

An important point was thus settled beyond a doubt: electrical vibrations are perpendicular to the plane of polarization, like luminous vibrations in the theory of Fresnel.

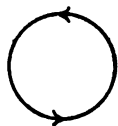

FIG. 55.—A circularly polarized ray may result from reflection of a plane-polarized one.

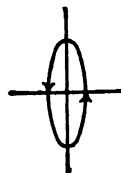

FIG. 56.—In an elliptically polarized ray, the amplitude of the vibration has maxima and minima in two perpendicular planes.

Reflection from a metallic surface produces, as with light, an elliptic or circular polarization.

Righi's apparatus serves readily to demonstrate this polarization. Give the resonator different orientations: if in one position there is complete extinction, the polarization is plane (Fig. 52); if the sparks have the same intensity in all azimuths, it is circular. (Fig. 55.) In an intermediate case, where the spark passes through a minimum without vanishing, the polarization is elliptical. (Fig. 56.)

8. Refraction.—At an early date prisms and lenses were constructed of sulphur or paraffin, which acted on electric waves as prisms and lenses of glass act on light.

Refraction affects the plane of polarization according to the same laws as in optics. The effect may be made more evident by multiple reflections and refractions, in imitation of the optical phenomena with piles of glass plates.

The following curious experiment is due to Professor Bose. We know that powdered glass is opaque to light on account of multiple reflections, but that its transparency is restored by pouring on Canada balsam, which has the same index of refraction as glass. In like manner, if we fill a box with irregular bits of resin, electric waves cannot pass through it; but its transparency is restored when we fill the chinks with kerosene.

We may note in passing that certain substances, like sulphur, are opaque to light because they are composed of minute crystals whose faces produce reflections. They behave like powdered glass. But they are quite transparent to electric waves, because the crystals are very small compared to the wave-length, and, with reference to these radiations, the substances must be considered homogeneous.

9. Total Reflection.—The phenomena of a total reflection and the resulting circular polarization are easily imitated, but there is a curious circumstance which seems well worthy of note.

According to theory, when a ray of light undergoes total reflection, a portion of the disturbance finds its way into the second medium, in conformity with certain particular laws. The effect is not visible, however, for the disturbance penetrates only a superficial layer whose depth is a wave-length.

This theoretical deduction cannot be verified directly in optics; we must rest content with indirect experiments comprising an intermediate phenomenon similar to that of Newton's rings.

With very long waves, however, the verification becomes



possible, and is quite satisfactory; so that here it is electric waves which reveal to us one of the secrets of light.

10. Double Refraction.— Crystals are doubly refracting to electric waves, but as they can be used only in very thin layers we have the same phenomenon as occurs in the polarizing microscope when a thin crystalline film is interposed between the polarizer and the analyzer.

Professor Bose used for polarizer and analyzer the polarizing grids of Hertz.

Care must be taken not to confuse two phenomena, whose effects, in this apparatus, are similar. They are generally superimposed, and require much care in their separation.

Crystalline bodies have different indices of refraction for vibrations in different planes: this is double refraction, properly speaking. But, in addition, these different vibrations are unequally absorbed: this is called, in optics, dichroism.

Both phenomena have been demonstrated. Dichroism is observed especially in bodies of lamellar or fibrous structure, such as wood, a book, or a lock of hair. Their mode of action is comparable to that of the polarizing grid of Hertz.

Professor Bose has shown that dichroism to electric waves is always accompanied by unequal electrical conductivity in the two directions.

CHAPTER XII.

SYNTHESIS OF LIGHT.

1. **Synthesis of Light.**—All these experiments put in evidence the complete analogy between light and rays of electric force.

If the period of these rays, short though it is already, were a million times shorter yet, they would not differ from rays of light.

We know that the sun sends us radiations of various kinds; some are luminous, because they impress the retina; others are dark — ultra-violet or infra-red — and are manifested by chemical or calorific effects. The former do not owe the properties which enable us to perceive them to any different nature, but to a sort of physiological accident. To the physicist, the infra-red differs no more from red than red from green — simply the wave-length is greater. The wave-length of Hertzian radiations is very much greater yet, but the difference is only one of degree; and we may say, if Maxwell's ideas are correct, that the illustrious professor of Bonn accomplished an actual synthesis of light.

The synthesis, however, is not yet complete, and a first difficulty arises from the great wave-length.

We have seen that light does not follow exactly the laws of geometrical optics, and the deviation, caused by diffraction, becomes more considerable as the wave-length increases. With the great wave-length of Hertzian oscillations these phenomena must become of great importance and influence everything else. Doubtless it is fortunate, at least for the

moment, that our methods of observation are so crude; otherwise, the simplicity which at first attracted us would give place to a maze in which we should be hopelessly lost. We have here a probable explanation of certain anomalies which have thus far been inexplicable.

From this point of view, the smallness of our bodies and of everything that we use is the only obstacle to a perfect synthesis. To giants, measuring length in thousands of kilometers, that is, in millions of wave-lengths of Hertzian oscillations, and reckoning time by millions of vibrations, Hertzian rays would be the same as light is to us.

2. Other Differences.—Unfortunately there are still other differences, notably the fact that Hertzian oscillations are very rapidly damped, while the duration of a luminous wave is counted in trillions of vibrations. This explains, as we have seen, the phenomena of multiple resonance, which have no optical analogue.

But this is not all; let us realize what ordinary light is. In the tenth of a second (that is, during the persistence of an impression on the retina) the direction of the vibration, its intensity, its phase, and its period change millions of times; yet they remain practically constant throughout millions of vibrations,—in short, the number of vibrations per second is reckoned in millions of millions.

With Hertzian oscillations the case is far from being the same:

First. They do not take all possible orientations, as do the vibrations of ordinary light; but maintain a constant direction, like those of polarized light.

Second. Their intensity, far from remaining constant during millions of vibrations, decreases so rapidly as to disappear after a few oscillations. After being extinguished, the vibrations do not recommence at once with a new intensity

and a different phase and orientation, but there is a long pause — much longer than the period of activity — which is not broken until the vibrator of the Ruhmkorff coil again operates.

We have seen (page 77) that the amount of energy radiated by an oscillator is not the same in all directions; it is maximum at what we have called the equator and zero at the poles. Why does not light follow the same law?

A source of light, at any given instant, does not emit the same amount of energy in all directions; here also, there is a maximum at the equator. But, *in a tenth of a second the equator has changed so many times that it has taken all possible orientations*; consequently, our eye, which perceives only averages, declares the illumination uniform.

What would be required to accomplish a complete synthesis of light? We should have to concentrate into a small space an immense number of oscillators oriented in all possible directions; these oscillators should operate either simultaneously or in succession, but without interruption — that is, each must be set in action before the oscillations of its predecessor have entirely ceased. Finally, to observe the radiations, we should need an instrument which would indicate mean values of the energy received, and whose impressions, like those on the retina, would persist during trillions of the oscillations observed.

The result would be an analogue of white light, *even if all the oscillators had the same period*, because of the damping.

To obtain something analogous to monochromatic light we should require oscillators, not only of practically the same period, but with a very small decrement.

3. Explanation of Secondary Waves.— We have considered (page 94) the secondary waves discovered by Righi,

which are emitted by resonators or dielectric masses placed in the vicinity of an oscillator. These phenomena seem, at first, to have no optical analogue.

We cannot compare them to what takes place when a body, absorbing the light which passes through it, is heated sufficiently to become luminous itself. In this case the transformation is not direct, but must pass through the intermediate state of heat; moreover, there is no essential relation between the phase of the vibrations emitted by the incandescent body and that of the radiations which excite them. Hence, *these vibrations cannot interfere with each other.*

Again, we cannot make a comparison with the phenomena of phosphorescence, because neither can the vibrations emitted by a phosphorescent body interfere with the vibrations which excite them.

The analogy must be sought elsewhere.

If secondary waves are formed, it is because part of the primary radiation has been *diffracted* by the resonator or the dielectric mass. But this kind of "diffraction" differs greatly from that to which we are accustomed.

First, the deviation is enormous, because the dimensions of the diffracting body are comparable to the wave-length.

In the second place, the phenomenon depends upon the nature of the diffracting body, and not only on its form as the geometrical theory of Fresnel demands; but this theory is only approximate, and applies only to small deviations, as is shown by the experiments of Gouy on the light diffracted by the edge of a razor.

Finally, the secondary waves produced by resonators are not generally of the same nature as the incident waves; but so in optics, the nature of the diffracted light is not the same as that of the incident light,—thus, if the incident light is white, the diffracted light is generally colored.

But, in the experiments of Hertz and of Righi, this alteration of the radiations by diffraction appears in a quite unusual garb, and we hesitate to recognize it.

The damping of the oscillator is more rapid than that of the resonators, hence it happens that the secondary waves which correspond to diffracted light still persist after the incident waves have disappeared. This paradoxical case of diffraction seems quite natural when we reflect a little.

A damped vibration may, from a certain point of view, be compared to a complex vibration whose components have no decrement. What happens at the end of a certain number of oscillations? We find that each of the components has retained its original intensity, while the resultant vibration is extinct. How can this be? The resultant is extinguished, because the components are mutually destroyed through interference.

Diffraction will analyze this complex vibration, as it analyzes white light, separating the different colors. If it allows only one of the components to remain, the mutual interference of the components can no longer result in destruction. The incident light, in which all the components are found together, may thus become extinct while the diffracted light, which contains only one, shines still.

With ordinary light such a phenomenon never occurs; neither would it be produced with Hertzian light if, instead of a single oscillator, we had a great number of them, arranged as explained on page 103. They would come into action at irregular intervals, but independently of each other, and they would be so numerous as to preclude the possibility of the concert being ever interrupted. Thus the synthesis of light would be more perfect, and under these conditions the incident waves would no longer sink to zero.

A recent experiment has shown more clearly the optical analogies of Righi's secondary waves.

Garbasso caused Hertzian radiations to fall upon a sort of discontinuous screen made up of a number of precisely similar resonators. This screen reflected secondary radiations whose period and decrement were the same as those of the resonators.

This phenomenon, whose analogy to that of secondary waves is evident, could be reproduced optically. A plate of silvered glass was ruled with two rectangular series of very fine equidistant cuts, extremely close together, which removed the film of silver, leaving a multitude of minute silver rectangles, like so many tiny resonators.

This apparatus acted on infra-red light as did Garbasso's, of which it was a miniature reproduction, on Hertzian rays.

4. Miscellaneous Remarks.—Two luminous rays arising from different sources cannot interfere, for the following reason: We may imagine each of these rays to have been produced, as described above, by a great number of oscillators vibrating independently of each other and coming into action at irregular intervals.

During a tenth of a second, all these oscillators operate successively, and the difference of phase of the two interfering rays changes a great number of times; sometimes they are cumulative, sometimes mutually destructive; and the eye, which perceives only a mean effect, sees neither reinforcement nor diminution — it sees no interference. A single pair of oscillators would produce interference fringes, but the different systems of fringes produced by the different pairs of oscillators are not regularly superimposed; they mingle promiscuously, and we see only a uniform illumination.

These considerations do not apply to the case of two Hertzian rays, each produced by a single oscillator, with a

single interruption of the primary of the coil. The interference fringes do not mix, for there is only one system of fringes. The two rays, though of different origin, may interfere.

The interferences cannot always be easily observed, because, generally, the second oscillator will not commence to vibrate until too long after the first has come to rest; but the result could be accomplished by feeding the two oscillators from the same coil, if the damping is not too great. Here again is a difference from optics.

We may ask again, what is the optical analogue of propagation along a wire? The corresponding optical phenomenon cannot be observed, because, owing to the smallness of the wave-length, it is confined, whether in air or in a metal, to a layer one or two thousandths of a millimeter in thickness.

However, we can find an approximation in the luminous fountain phenomenon, where the light follows a stream of liquid. This comparison, less crude than it seems, is nevertheless very imperfect, because metallic wires are conductors, while the liquid stream acts, with respect to light, as a transparent dielectric.

Yet, it is doubtless possible to reproduce with Hertzian rays the luminous fountain phenomenon. We could then arrange a series of models with dielectrics of increasing specific inductive capacities, ϵ (cf. Chapter IX), and the case of a metallic wire would appear at the end of the series as a limiting case.

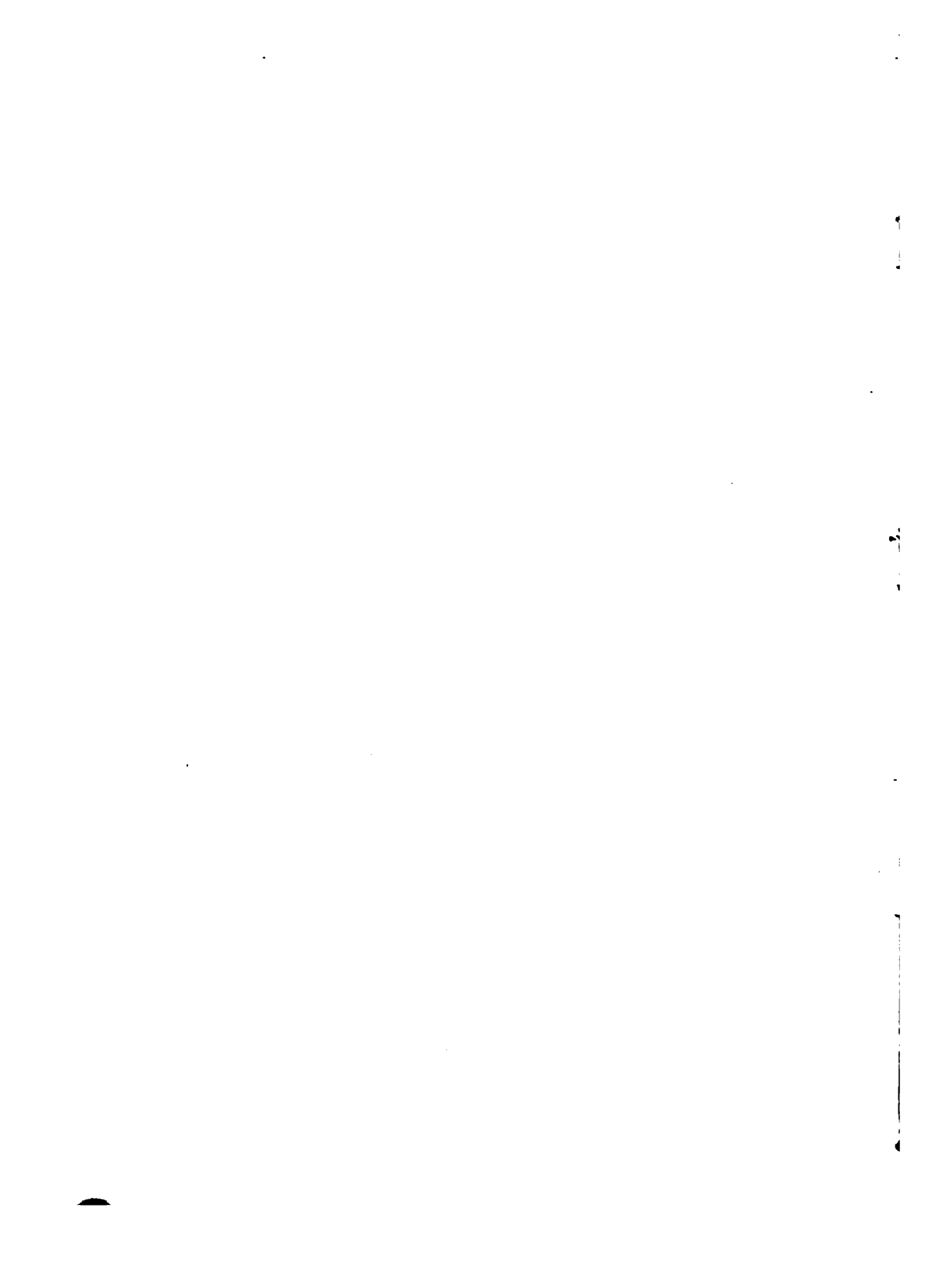

PART TWO.

THE PRINCIPLES OF WIRELESS TELEGRAPHY.

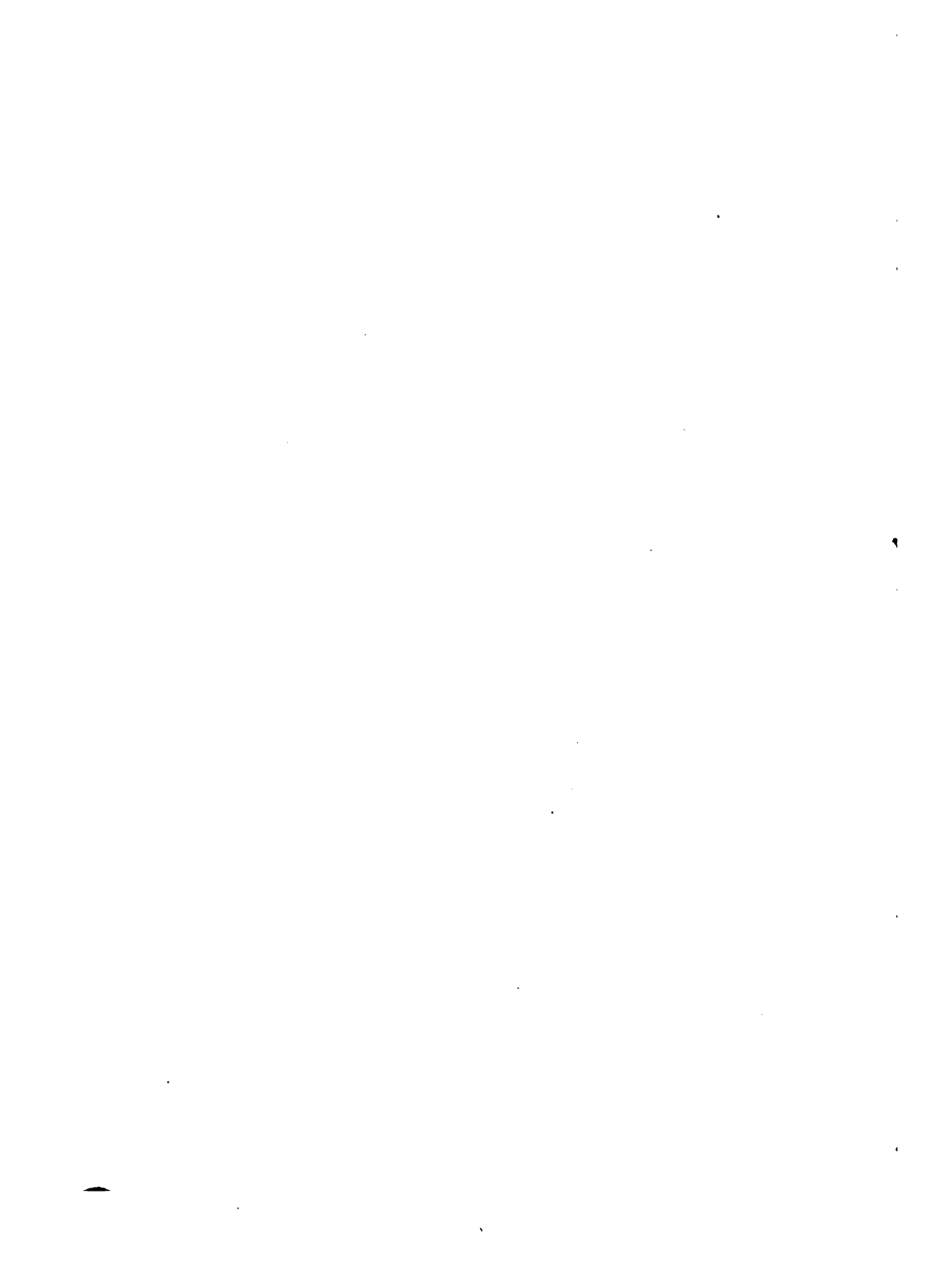

PART TWO.

THE PRINCIPLES OF WIRELESS TELEGRAPHY.

CHAPTER I.

GENERAL PRINCIPLES.

1. Methods of Signaling Through Space.—In the foregoing chapters M. Poincaré has outlined the fundamental principles which underlie all electrical phenomena, according to Maxwell's theory, and has shown how they apply to the production of electromagnetic waves in space.

Let us now carry the application a step farther, and see how these principles are involved in the practical problem of signaling through space without line wires: a problem which is daily growing in importance, and which promises to bear fruit of great industrial value.

The problem is not a new one, nor are the methods of solving it altogether novel, for we have seen them foreshadowed on every page of the preceding chapters; but the development of the art has brought out many interesting features which we cannot afford to overlook.

We have seen that there are three modes by which an electrical disturbance may be transmitted through space:

- a. By electromagnetic induction,
- b. By electrostatic induction,
- c. By electromagnetic waves;

the last being a complex phenomenon including the effects of both the others.

All three of these modes of transmission have been used by different experimenters for the sending of signals, though the last is the only one that has attained great practical value; but as they all illustrate important principles, we shall consider each briefly before passing on to the more practical phases of the subject.*

In order to crystallize our ideas, let us return to a mechanical analogy.

Suppose we have a body of water with operators stationed at two points of the surface, A and B. The operator at A may send a signal to the operator at B by any one of three methods:—

- a. By setting the water in motion and causing it to flow as a whole from A to B — a *Dynamic method*;
- b. By raising or lowering the level over the whole surface — a *Static method*;
- c. By raising and lowering the level at frequent periodic intervals and starting a series of progressive impulses over the surface — a *Wave method*.

Let us see how these three illustrations apply to the three methods of signaling through space.

* A fourth method which might be included under the general head of "Wireless Telegraphy" is the method of electric conduction, in which the earth or sea is made part of a circuit carrying a current, which spreads out over a wide area. Part of this current is shunted out at the desired point through two immersed or buried plates, and is made to operate a receiving apparatus. As the transmission here is wholly through a material medium, and not through space, we need not consider it further.

2. **Method of Electromagnetic Induction.**—Imagine a screw propeller, rotating beneath the surface at A, and causing currents of water to flow toward B. (See Fig. 57.) At B is a second screw, pivoted so that it can rotate under the influence of the water currents, but restrained by a spring. The transmission from A to B is then of a dynamic nature; the energy used to rotate the sending propeller is stored up in the moving water, which, when it strikes the screw at B, causes it to rotate until arrested by the compression of the spring, and so gives up part of its

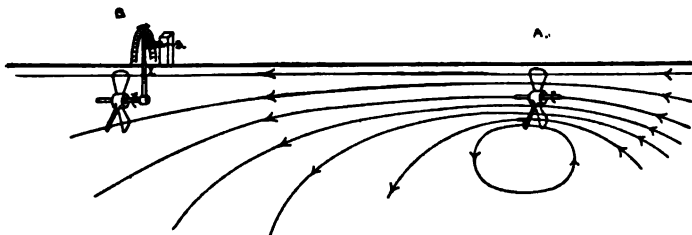

FIG. 57.—Dynamic method of signaling through water. The propeller at A sets up currents in the water, which tend to rotate the screw at B, compressing the spring S and moving the index I. The arrows on the stream lines indicate the direction of flow.

energy to move an index and produce a signal. But the receiving screw will not move unless the speed of the propeller, and hence the velocity of the water, changes. When the propeller is started, the index moves in, say, a positive direction; when it is stopped, the index moves back in the negative direction; if the motion be reversed, the index moves again in the negative direction, and so on.

This is analogous to the process of signaling by electromagnetic induction. Imagine a loop of wire (C, Fig. 58), carrying a current. We have seen that such a current represents a supply of energy, which is stored in the

medium surrounding the loop as a mode of motion.* If we have a similar loop of wire at D, containing a voltmeter, any change in the current at C will cause a deflection of the voltmeter at D and give a signal. The analogy is quite close: an increase in the current at C will produce a deflection in one direction, while a diminution or reversal of the current will cause a deflection in the opposite sense.

The kinetic energy stored in the medium is manifested in the magnetic field surrounding the loop: if we place a

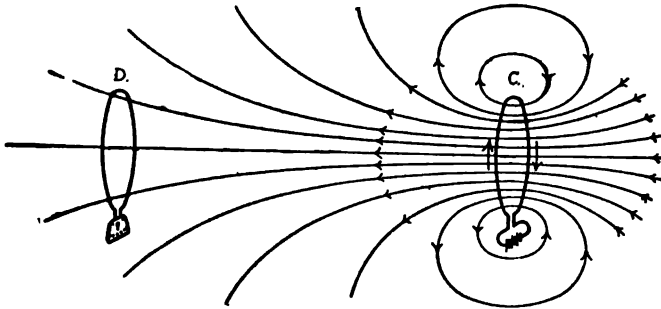

FIG. 58.—Method of signaling by electromagnetic induction. A current in the loop of wire at C sets up a magnetic field in the surrounding medium. Any change in the intensity of this field will induce an EMF in the loop at D, and give a signal. The lines of magnetic induction may be compared to the stream lines in Fig. 57.

compass needle at any point of this field, it will take a position parallel to the direction of the magnetic force at that point, just as a pivoted vane immersed in the water will place itself parallel to the direction of flow. Thus we

* It must be borne in mind that Maxwell does not attempt to define the actual nature of this disturbance in the ether, but simply shows that it follows all the laws of the analogous phenomenon in matter.

may plot a series of lines of magnetic induction, or "lines of force," throughout the field, corresponding to the stream lines in the water. The direction of the lines indicates the direction of the magnetic force, and their proximity to each other, its intensity; just as the stream lines indicate the direction and velocity of the flow. The significance of these lines will appear later.

3. Preece's Apparatus.—Sir William Preece has applied this method with considerable success over short

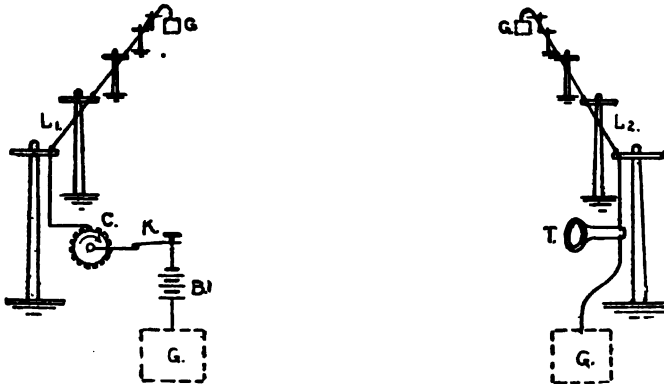

FIG. 59.—Preece's apparatus for signaling by electromagnetic induction. An intermittent current produced by the battery B and commutator C, and controlled by the key K, is sent through the line L_1 , and returns through the earth. The receiver comprises a similar line, L_2 , whose circuit includes a telephone receiver, T.

distances.* His sending apparatus comprises a long wire, supported on poles as high as possible above the earth, and grounded at both ends; the circuit including a battery and a key for making and breaking the current. (See Fig. 59.)

* See Preece *Ætheric Telegraphy*, Jour. Instn. Elec. Engrs., v. 27, p. 869, 1898.

The receiving apparatus is a similar conducting circuit parallel to the first, and including a telephone. Each time the current is made or broken in the sending circuit, a current is induced in the receiving circuit and a click is produced in the telephone. In his improved apparatus Preece used a rotating commutator, in series with the sending key, whereby the circuit was made and broken some 200 times per second. The resulting succession of impulses produced a musical note in the telephone, which, when

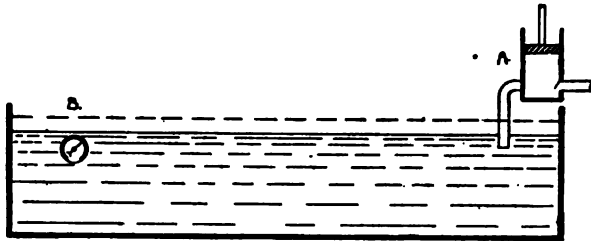

FIG. 60.— Static method of signaling through water. The pump at A raises or lowers the level of the water, and a gauge at B indicates the variation of pressure.

interrupted by the sending key, gave easily readable dots and dashes.

With this apparatus Preece worked successfully across the English channel, but the size and cost of the equipment increases very rapidly with the distance, and a practical limit is soon reached. The reason for this will appear later.

A similar method was used by Phelps for telegraphing to and from moving trains. In this case, a coil of wire encircling the car created a magnetic field whose variations induced currents in an ordinary telegraph wire stretched along the track.

4. Method of Electrostatic Induction.—The second method of sending a signal across our body of water is the static method — by raising or lowering the level of the water, and hence the pressure at a given point beneath the surface, without causing any motion of the water, as a whole, from A to B. For example, a pump at A forces water into the reservoir, thus raising its level, and a pressure gauge fixed below the surface at B indicates the change of level to the receiving operator. (Fig. 60.) There is a

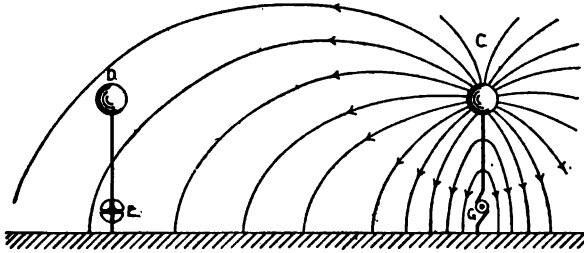

FIG. 61.—Electrostatic method of signaling through space. An insulated conductor C is charged to a high potential by a generator, G, and produces an electrostatic stress in the surrounding medium. The charge induced on a similar conductor, D, is indicated by an electrometer, E. The curves radiating from the conductor C are lines of electric displacement in the ether.

transitory flow of water from A outward in all directions while the pump is in operation, but no general motion from A to B, as there was in the case of the dynamic method. The flow continues only while a change of level is taking place, and represents but little energy. Practically all the work done by the pump is expended in raising the level of the whole body of water: it is thus stored up as potential energy, due to the increased elevation, and manifested by an increase of pressure at every point beneath the surface.

So with the electrostatic method of signaling: an insu-

lated conductor, supported above the earth at C (Fig. 61), is charged to a high potential by a high-voltage generator, and sets up a state of electrostatic stress throughout the surrounding medium. This is made manifest at D by an electrometer connected to a second elevated conductor. According to Maxwell's theory, when a current flows from the generator to charge the insulated conductor, a series of displacement currents are set up in the ether, flowing in all directions from the conductor; but these currents are necessarily of a transient nature, and exist only while the displacement is taking place, which results in the strained condition of the ether which is called an electrostatic field. This field, like the magnetic field described in section 2, represents an accumulation of energy; but the energy is of a potential nature, and results from the displacement of the medium against its elastic reaction. It, also, may be represented by a series of lines — the lines of electric force, or electric displacement — each line following the direction of the displacement in the medium, and the proximity of the lines at a given point being a measure of the intensity of the field, or the degree of displacement, at that point.

Thus far the hydraulic analogy has held, but here it fails in an important point. The displacement in the ether is of an elastic nature, and the intensity of the reaction, or electric force, depends upon the degree of the displacement. Hence, near the charged conductor, where the displacement is great and the lines of displacement are close together, the electric force is comparatively large, and it diminishes rapidly as we proceed from the conductor. In the water, however, where the force of gravity is constant and independent of the displacement of the particles of water, the

level will be the same all over the surface, and an increase in pressure at A will be transmitted undiminished to B.

This discrepancy will disappear if we assume, in place of water, a semi-solid or jelly-like substance, sufficiently mobile to flow under the influence of gravity, yet with an elasticity which resists any displacement with a continuously increasing force. If now we raise the level at A, the whole surface will slope downward from this point, as shown in Fig. 62, and the pressure due to this raising of

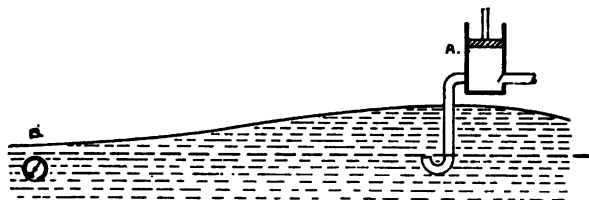

FIG. 62.—A more complete mechanical analogue of the electrostatic method. The medium here is an elastic jelly, which is strained by the pressure of the pump, and the displacement diminishes rapidly with the distance.

the level will diminish rapidly as we proceed from A toward B.

5. Dolbear's and Edison's Apparatus.—Prof. Dolbear constructed an apparatus on this principle, as illustrated in Fig. 63.* An induction coil having an automatic break is provided also with a key for opening and closing the circuit at will, and its secondary terminals are connected, one to a wire leading to a gilded kite, the other to ground. At each interruption of the primary circuit, the aerial conductor is charged to a high potential, and electrifies by induction a similar conductor at the receiving station.

* A. E. Dolbear, U. S. pat. No. 350, 299, Oct. 5, 1886.

Here the induction coil is replaced by a telephone receiver, and the currents set up in the telephone by the alternate charging and discharging of the aerial wire produce a buzzing sound similar to that emitted by the vibrator on the coil.

Messrs. Edison and Gilliland devised a system embodying the same idea in a somewhat different form, which they used for telegraphing to and from moving trains.* (Fig. 64.) On the roof of the car is fixed a sheet of metal attached to the secondary of an induction coil, the other terminal of the secondary being grounded. The primary of the coil is worked, as in Dolbear's apparatus, through a key and an automatic break. The metal roof acts by electrostatic induction on a wire stretched along the side of

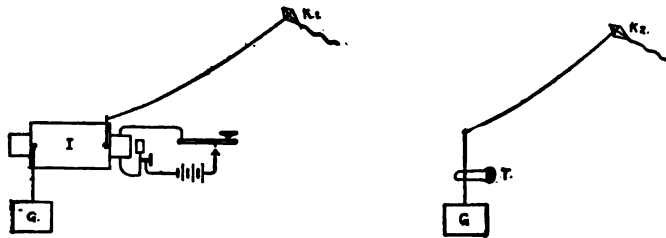

FIG. 63.—Dolbear's apparatus for electrostatic signaling. A kite K_1 at the sending station is charged by an induction coil I , and another kite K_2 at the receiving end is grounded through a telephone, T .

the track, and the currents induced therein are made to operate a telephone at the receiving end of the line. When it is desired to receive a message on the train, the induction coil is cut out and a telephone receiver substituted, while at the sending station a large plate suspended near the

* See Eng. pat. No. 7,583, June 22, 1885.

line wire is charged and discharged by means of an induction coil. Charges are thus induced in the line wire, which carries them on until they are picked up, again by electrostatic induction, by the train.

This system was put in practical operation on several railroads, but was finally abandoned on account of the limited use that was made of it.

6. Method of Electromagnetic Waves.— We now come to the third and most important method of signaling through space — the method of electromagnetic waves.

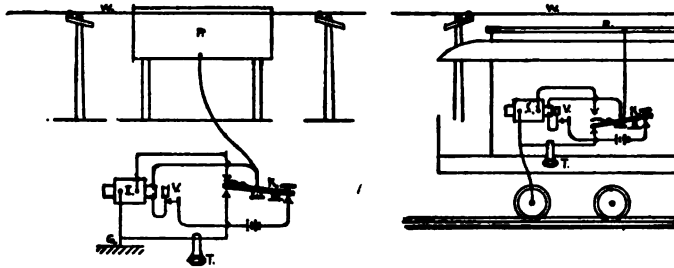

FIG. 64.— Electrostatic method of train telegraphy. At the land station (which is shown in sending position), the line wire W is excited by an elevated metallic plate P, charged by an induction coil I, operated by a key K and vibrator V. On the train a similar apparatus is connected to the metallic roof R of the car. Here the key is shown elevated, thus putting the telephone T in connection for receiving.

We have seen that either an electrostatic or an electromagnetic field may exist by itself, without the other, but *the condition on which this is possible is that it shall be invariable*. If an electrostatic field varies, it at once produces an electromagnetic field, and *vice versa*.

Let us return to our hydraulic analogy:

In the arrangement shown in Fig. 60, as long as the pump is not working and the level of the water is constant,

there is no motion ; but let us endeavor to change the level by starting the pump, and at once a flow is produced. Similarly in Fig. 57: as long as the propeller is working uniformly and the water is moving with constant velocity, no variation in pressure occurs; but let the speed of the propeller vary or the velocity of the water change in any way, and at once a pressure is produced and a change of level occurs. The water in motion possesses kinetic energy: if we cause it to give up any of this energy by checking its velocity, it exerts a pressure which causes its

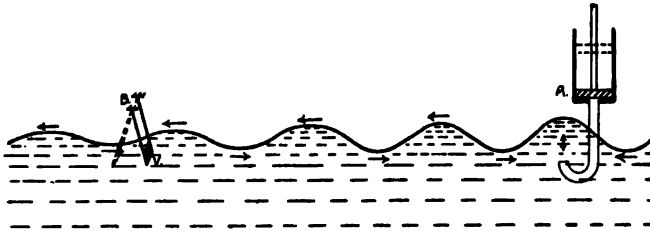

FIG. 65.— Wave method of signaling over water. The pump here has no valves, and alternately sucks in and expels water at periodic intervals. The waves thus started move a swinging vane, V, at the receiving station B. Energy is radiated, but the water only moves to and fro.

level to rise, and the energy takes the potential form due to the increased elevation.

Suppose now, instead of the continuously acting pump in Fig. 60, we have a simple cylinder and piston, whereby water may be forced into and out of the reservoir alternately. (Fig. 65.) When the piston is pushed down, a quantity of water is forced out and the level is raised; but this elevation in one spot can exist only for a moment: the very act of raising the crest gives the water a velocity, which it imparts with its neighboring particles, shoving

them before it; they in turn communicate their motion to others, and so the elevation travels outward in an expanding ring. But while this is taking place the piston has been raised, drawing the excess of water out of the reservoir and creating a depression. The particles which have been moving outward in the crest now start back to fill this depression, and in so doing create a trough to be filled, in turn, by other particles left behind by the advancing crest. We thus have a series of elevations and depressions, moving outward in ever-expanding circles, trough following crest and crest following trough, carrying with them the energy supplied by the pump: in other words, a train of waves.

These waves, when they reach the receiving station at B, may be detected, either by a pressure gauge which follows the variations of level, as in Fig. 60, or by a pivoted vane which moves with the motion of the water, as shown in Fig. 65.

Let us now see how this compares with what takes place when an oscillator is set in operation:

Take again our elevated conductor, but instead of the continuous current generator put an alternator giving a current of very high frequency. At the moment when the generator is giving its maximum voltage and the conductor is fully charged, we shall have a state of affairs similar to that shown in Fig. 61; the whole surrounding medium being in a state of electrostatic stress, or electrical displacement. But this state of displacement was not produced instantaneously throughout the whole field—the disturbance began at the conductor and spread outward with the velocity of light, in somewhat the same way as the hydraulic crest expanded from the center where it was formed.

Before the electrostatic field has become fully established the voltage of the generator begins to diminish, and the conductor discharges itself through the wire to ground. The state of stress about the conductor gives way to a condition of change, and displacement currents flow back along the lines of force toward the conductor. While this is taking place, the current flowing from the conductor to ground is setting up an electromagnetic field, the lines of magnetic force forming closed circles about the wire.

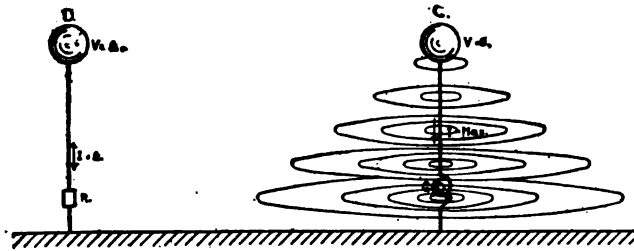

FIG. 66.— Signaling by electromagnetic waves. The conductor C (cf. FIG. 61) is charged by a source G of high-frequency alternating current, and excites waves which expand until they reach the receiving conductor D, and induce alternating currents which are detected by the receiving apparatus R. The circles indicate the lines of magnetic force at the moment when the conductor C is discharged, the potential $V = 0$, and the current I is a maximum. FIG. 61 shows the electrostatic lines when $I = 0$ and $V = \text{Max}$.

Finally, when the conductor is completely discharged and the current in the wire is a maximum, the electrostatic field has entirely disappeared from the region close about the oscillator, and we find in its place the electromagnetic field shown in Fig. 66.

But this is not all; the very act of changing the intensity of the electrostatic field produces a magnetic force. If a conduction current in the vertical wire produces a magnetic field about it, why should not a displacement cur-

rent in the ether do the same? This is, in fact, the case, according to Maxwell's theory. Not only close about the wire do these circles of magnetic force exist, but wherever the electrostatic field is varying the magnetic field goes with it. As the advancing crest of a water wave is accompanied by an outward motion of the particles which compose it, so the electrostatic crest of our electric wave carries with it a dynamic field of magnetic force, whose ever-enlarging circles swell outward with the expanding wave.

It is this union of electrostatic and magnetic fields in a progressive disturbance which constitutes a true electromagnetic wave. Neither alone can produce a wave, but both must be combined inseparably in the proper mutual relation. We shall see more of this in Chapter IV.

Now returning to the sending apparatus (Fig. 66), we shall see that the frequency of the generator has a great effect on the energy of the waves given off. The strength of the electrostatic field about the elevated conductor depends simply upon its charge, and hence upon the voltage of the generator; but the strength of the magnetic field which goes to make the wave depends upon the intensity of the displacement currents, and hence on the rapidity with which the conductor is charged and discharged. If the frequency of the generator is low, the magnetic effect of the oscillation is small, and the energy of the electrostatic field is mainly returned to the generator when the conductor discharges. As the frequency increases, the increasing magnetic energy of the field unites with a portion of the electrostatic energy and is radiated into space, never to return.

Take another mechanical illustration: — A fan is moved slowly to and fro; it sets the air in motion and stirs a

floating feather near by, but the motion is so slow that no appreciable pressure is produced, and no waves are given off. Now let the fan move faster and faster, until it approaches the condition of a vibrating tuning fork. Here the air is set in motion so violently that great variations in pressure are produced, along with the variations in velocity — true waves are given off, and the sound of the fork is heard at a long distance.

So with our oscillator: if the frequency is low, as in Dolbear's experiments, we get only a local electrostatic disturbance; but if the frequency be sufficiently high, there is true radiation of electromagnetic waves, which travel to a long distance.

In practice, the highest frequencies attainable by mechanical means — a few thousand per second — are inadequate for the purpose; the amount of energy radiated is too small to be of practical value. We are forced to make use of the free oscillations which occur when a charge surges back and forth on a conductor, giving off a train of waves of short duration but large amplitude.

7. Comparison of the Three Methods.— One feature that is common to both the inductive methods, and makes them impracticable for long-distance signaling, is the fact that the intensity of the field — magnetic in one case, electrostatic in the other — diminishes very rapidly as the distance from the source increases. This may be seen by referring to Figs. 58 and 61. If the lines of force were straight, diverging in all directions from the source, like rays of light, the intensity of the field would follow the simple law of inverse squares, and doubling the distance from the source would give us one-quarter the strength of field.

But this is far from being the case. In Fig. 58 we see that the lines of magnetic induction are nearly straight where they start from the source, but they soon bend back to form closed loops interlinking with the sending circuit, and only a small proportion of them reach any considerable distance. Calculation shows that where the distance between the sending and receiving circuits is great compared with their diameters the strength of field falls off practically as the cube of the distance, and if perchance there were a mass of magnetic material near the receiving station, this would still farther deflect the lines from the receiving loop, and so diminish the effect.

When we consider that the *energy* of the field, which is available for working a receiver, varies as the square of its intensity, the limitations of this method become only too apparent. Lodge has calculated that to send a message from London to New York, under the conditions of Preece's experiments, would require a sending circuit encircling the whole of England and a receiving circuit as big as the state of New York.*

A similar line of reasoning applied to the electrostatic method would disclose a similar result: that we must greatly increase the size and power of the sending apparatus for a comparatively small increase in the distance to be covered.

Again, the rate at which the energy of the field may be taken up by the receiver depends upon the rate at which its intensity is varied. A rapidly varying field — magnetic or electrostatic — produces powerful inductive ef-

* See O. J. Lodge, *Jour. Instn. of Elec. Engrs.*, v. 27, p. 800 *et seq.*, 1898.

facts, while a slowly varying field parts with its energy less readily. In the case of the electromagnetic method, the rate of variation is limited by the self-induction of the sending circuit — that species of inertia which opposes any change in the current. If we increase the size of the circuit with a view to strengthening the signals, we increase also the self-induction, and so lose in speed much of what we gain in strength of the field.

In the case of the electrostatic method this objection is not so evident, for the self-induction of the aerial wire is small, and its capacity, though it acts in the same direction, is still small enough to permit of very rapid variations. But we must not overlook the effect of the induction coil or generator which charges the conductor. This has a large self-induction, and so the apparent advantage of this method is lost.

But one may ask, why not use the induction coil simply to charge the conductor, and then suddenly short-circuit it, and allow the charge to flow rapidly back to earth?

This is precisely what is done in using the method of electromagnetic waves, and therein lies its great advantage. When the potential of the conductor reaches a certain point, it breaks down an air-gap separating it from the ground, and the spark thus formed acts as a short circuit of low resistance and allows the charge to flow rapidly to earth.

As we have already seen, such a discharge is not a simple unidirectional one, but oscillates back and forth with a frequency depending upon the self-induction and capacity of the apparatus, and starts a train of waves radiating in all directions from the source.

Here we have the advantage, not only of extreme rapidity of change in the field, but also of the fact that the

energy itself is radiated in straight lines, and so falls off with the distance much less rapidly than does the energy of the electrostatic or magnetic field, which is not radiated at all, but makes a short excursion into space, only to return again to its source.

Returning to the hydraulic analogy, we see from Fig. 62 that, in the statical method, the energy spent in raising the level of the fluid is not radiated — it is simply stored in the medium, to be returned to the source as soon as the pressure is relieved — and the elevation at a given point can never be greater than that due to the statical stress in the medium. When a wave is sent out, on the other hand, the crest started from the source travels outward, carrying energy with it. If the wave were shut in between parallel walls, it would continue undiminished in height, except as the energy were wasted in friction; if it be allowed to spread out in all directions, the amplitude will fall off as the circumference of the wave front increases, but still the height of the crest is much greater than the elevation caused by simple statical pressure from the source.

The same thing takes place when electromagnetic waves are sent out by an oscillator. As the wave expands, distributing its energy over a constantly widening area, the intensity of the field which accompanies it — the height of the crest, as it were — falls off simply in proportion as the distance from the source increases, and hence the energy of the field as the square of the distance.

The reason for this we shall see later. For the present let us be content with this simple comparison of the three methods, and look now more closely at the wave method of signaling.

CHAPTER II.

TELEGRAPHY BY HERTZIAN WAVES.

1. **Early Experiments.**—The early experiments with this method of wireless telegraphy, which the Germans appropriately call “spark telegraphy,” were made with much the same apparatus as that used by Hertz in his researches on free waves in space (see p. 74); indeed Hertz possessed all the essential features of a working telegraph system:—an oscillator emitting electric waves, which in this case were concentrated by a parabolic reflector, and a detector of these waves, which was an open resonator placed in the focus of a similar reflector, with a spark-gap to make its oscillations visible. (Fig. 44.) This apparatus was effective from end to end of the room at his disposal—a distance of sixteen metres.* Other experimenters, as we have already seen, improved the apparatus, and Lodge succeeded in working up to a distance of forty to sixty yards with such success that he considered a transmission of half a mile quite feasible; but none of these investigators seemed to see any practical utility in their experiments until Sig. Guglielmo Marconi appeared on the scene. This distinguished young Anglo-Italian, a pupil and compatriot of Prof. Righi, was quick to perceive the possibilities of the radiations which Righi had been investigating, and proceeded at once to turn them to practical account.

The first important problem to be solved was the per-

* Hertz, *Electric Waves*, Eng. trans., p. 176.

fection of a sensitive and reliable detector. The coherer of Branly offered great possibilities, but, in its crude form of a tube several inches long filled with filings and having its ends plugged with corks, it was very unreliable. Sometimes it was so sensitive as to be affected by trifling mechanical disturbances, such as the sound of the operator's voice, and again, for no apparent reason, it would refuse to work altogether. By dint of careful experimenting Marconi overcame these difficulties and succeeded in producing a coherer which could be depended upon to work fairly well under all conditions. It consisted in a small glass tube (see Fig. 67), 4 cm. long and .25 cm.

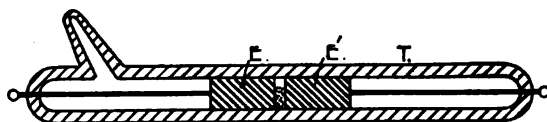

FIG. 67.—Marconi's coherer — longitudinal section. T is the glass tube, with leading-in wires terminating in the silver electrodes, E, E'. In the space between these are the filings.

bore, in which were fitted two silver plugs attached to terminal wires. The plugs were about one mm. apart, and the space between them contained a mixture of specially-prepared silver and nickel filings. The whole tube was then exhausted and hermetically sealed.

In its normal condition this apparatus has an extremely high resistance, but under the influence of electrical oscillations its resistance drops immediately to between 100 and 500 ohms. When this occurs a local circuit is completed through a battery and a sensitive relay, which in turn operates the recording apparatus and sets in motion

an automatic tapper, which strikes the tube of the coherer and restores it to its original condition of high resistance.

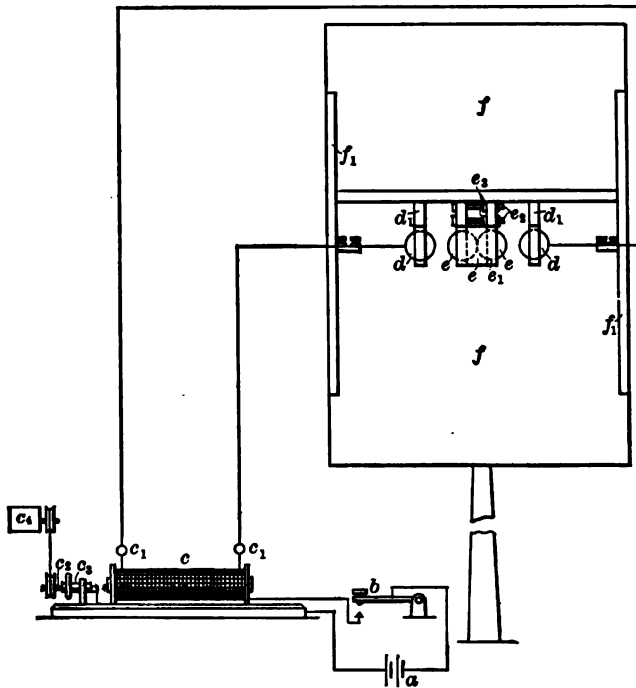

FIG. 68.— Marconi's early transmitting apparatus, consisting in a Right oscillator, *deed*, mounted in the focus of a parabolic reflector, *f*. *b* is a key for operating the induction coil *c*.

2. Marconi's Early Apparatus.*— An early form of Marconi's apparatus is shown in Figs. 68 and 69. The trans-

* See Marconi, Eng. pat. No. 12,039, June 2, 1896.

mitting device is a Righi oscillator (see p. 85) mounted in the focal line of a parabolic reflector of copper or zinc. The receiver comprises a similar mirror with a coherer placed in its focus. To the terminals of the coherer are attached two strips of copper, whose length is carefully adjusted so as to make the period of oscillation of the coherer system the same as that of the oscillator. Wires

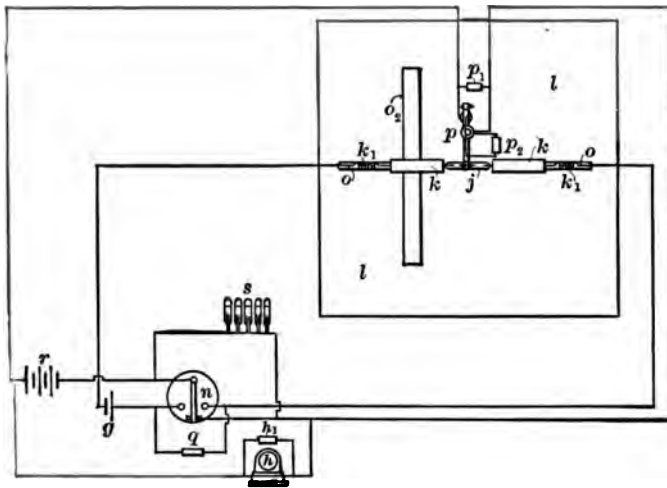

FIG. 69.—Receiver of Marconi's early apparatus. The coherer j is mounted on the focus of a second parabolic mirror l , and is provided with wings, k , whose length is adjusted to resonance. n is a relay and h the recording apparatus.

from the ends of the coherer pass through holes in the mirror to the relay and recording apparatus, which is shown diagrammatically in Fig. 69.

This arrangement, crude as it is, was used successfully over distances of two or three miles; but it has seri-

ous limitations. In the first place, the wave-length of the oscillator is very short — only a foot or so, depending upon the size of the balls. Such short waves are peculiarly susceptible to absorption by obstacles — a few buildings or a small hill in the path of the waves being sufficient to cut them off quite effectually — while a longer wave, comparable in size to the obstacles themselves, would be hardly affected at all. In like manner, a rock protruding from the water stops the small waves which pass over the surface, while the larger ones seem scarcely to notice it.

Another and even more serious drawback is the feeble intensity of the waves. How to increase their energy, and hence the distance over which signaling would be possible, was the next important problem to be solved.

The charged balls of the oscillator, at the moment the spark occurs and the oscillations commence, represents a certain amount of energy. This energy oscillates back and forth until it is all radiated into space or frittered away in the spark-gap, but no new supply can be drawn from the source, however powerful, until this is used up and a new spark occurs. All the energy of a wave-train must be stored in the charged conductors before the oscillations commence.

There are two ways of increasing this energy: first, by increasing the potential to which the conductors are charged, and second, by increasing the capacity of the conductors themselves. The former may seem at first glance the more promising, as the energy of the charge increases as the square of the potential; but a practical limit is soon reached. The difference of potential depends upon the length of the spark-gap; if we increase this beyond a certain point, the spark is so attenuated that the

discharge is not strong enough to keep it hot, and most of the energy is wasted in overcoming its ohmic resistance.

This difficulty may be partly overcome by causing the spark to break through oil, and so making a high potential possible with a short, thick spark which does not waste much energy. But even here a limit is soon reached, and it is necessary to fall back on the second means of increasing the energy,— by increasing the size and capacity of the oscillator. This has the further advantage of increasing

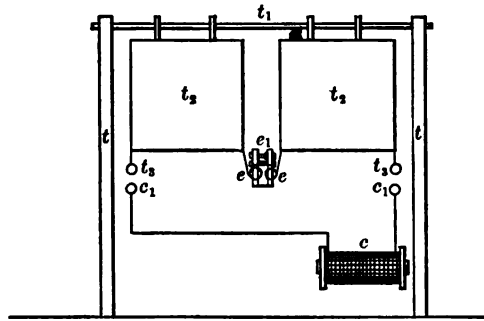

FIG. 70.—Marconi's improved apparatus with two capacity areas, t_2, t_2 .

the wave-length, and so reducing the interference of obstacles.

3. Improved Apparatus.—Another form of Marconi's apparatus is shown in Fig. 70.* The two balls of the spark-gap are connected respectively to two plates of metal, hung on insulators, which constitute the capacity areas of the oscillator;— in other words, Hertz's "large oscillator"

*Loc. cit.

(p. 34), magnified. The receiving apparatus is similar but the spark balls are replaced by a coherer.

A similar arrangement was used by Sir Oliver Lodge, who employed large conical surfaces, arranged like an hour-glass, in place of the flat plates.* (Fig. 71.)

The results of these experiments fully confirm the theory: with the larger apparatus, the distance over which signals could be transmitted was greatly increased, and it was found possible to dispense entirely with the large and

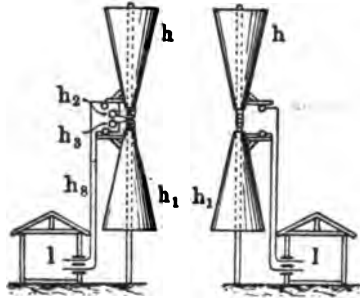

FIG. 71.—Lodge's conical capacity-areas.

cumbersome reflectors which had been used to concentrate the radiations. Indeed, Marconi showed that, other things being equal, the distance of transmission depended upon the size of the plates, *their height above the earth*, and, to some extent, their distance apart. The second point is a matter of importance, for it reminds us that the radiations we are dealing with are polarized, and that the displacements in the ether take place in a direction parallel

* See Lodge, Eng. Pat. No. 11,575, Feb. 5, 1898.

to the axis of the oscillator.* If the axis be horizontal, the waves striking the earth will induce currents parallel to the oscillator, and much of the energy will be absorbed and wasted in ohmic losses. Elevating the oscillator only diminishes the trouble, but does not remove it.

Lodge placed his oscillator in a vertical position, and so avoided this difficulty, only to fall into another — the very

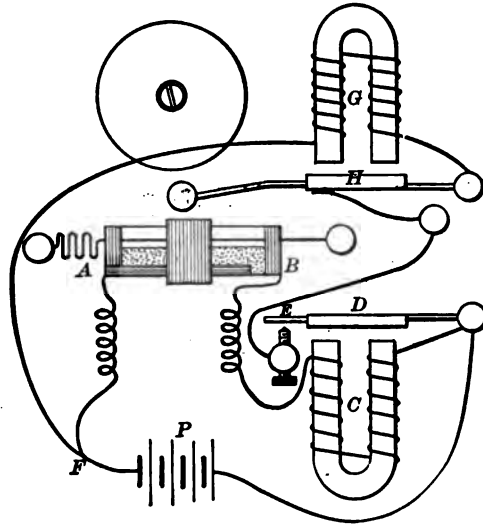

FIG. 72.—Popoff's receiver. AB, the coherer; CDE, the relay; GH, a combined bell and tapper.

practical one of supporting his large cones in the air and of providing means for getting at the spark-gap and other apparatus which must be placed between them.

But happily another solution was forthcoming.

*Approximately — See Chap. IV.

4. **The Antenna.**— About this time, Prof. Popoff, who had been using a modified form of the coherer in investigating the effects of distant lightning discharges,* undertook to apply the same apparatus to wireless telegraphy. His arrangement is shown in Fig. 72. The coherer, relay, and tapper were arranged in essentially the same way as Marconi's (p. 133), but instead of attaching capacity areas to the two terminals of the coherer, he connected one end to the ground and the other to a vertical wire, or *antenna*, supported by a mast.

This antenna played an important part in picking up the waves produced by lightning discharges, and the intensity of the effect was found to depend upon the height of the antenna — the longer the wire, the stronger the impulse. At first glance it would seem that the same should be true in wireless telegraphy; a high antenna, cutting a large slice out of the advancing wave-front, should take up more energy from the ether and give a stronger signal than would a shorter one. But in practice this was not the case; a limit was reached beyond which an increase in height had very little effect.

We must seek the explanation in the fact that the radiations dealt with in the two cases differ widely in character. We know that a lightning-flash is oscillatory, and that it sets up a train of waves which, as Popoff found, may be detected at long distances; in fact, when a discharge occurs between two clouds, or between a cloud and the earth, we have practically a huge Hertzian oscillator, giving off electromagnetic waves of tremendous energy. As the size of

* Popoff, *Jour. of Russian Physico-Chemical Soc.*, v. 28-29, p. 896, 1895.

the oscillator determines the wave-length of its radiations, and as ordinary Hertzian waves may be measured in metres, we might expect a great cloud-oscillator to emit waves several miles in length — and this is indeed the case.

Now, when a wave strikes an antenna, it induces an electromotive force in the wire. If the wire is vertical and the distance from the source is great, we may assume that the wire is parallel to the wave-front, and that all parts of it are affected alike. The disturbance started at the top travels downward with the velocity of light, gathering force as it goes; but by the time it has reached a point a half wave-length distant from the top, the incoming wave is reversed in phase, and the direct impulse received at that point destroys the effect of that transmitted from the top. At shorter distances, where the difference in phase is smaller, the interference is less complete; but there is evidently no advantage in lengthening the antenna beyond the quarter wave-length of the oscillations to be received, unless the object is to reach above the region affected by obstacles. With lightning discharges, the limit is never reached; but with the radiations of short wave-length used for telegraphing at the time of Popoff's experiments, it is little wonder that the results were disappointing.

Marconi went a step farther, and used an antenna at the sending station also — and this marks an epoch in the history of wireless telegraphy.* At once the limits in the size of the apparatus were removed indefinitely; the wave-length and power of the radiations were greatly increased; the interference of obstacles began to disappear: as the

* Eng. pat. No. 12,039, June 2, 1896, claim 16.

apparatus was perfected, the available range of signaling was increased at a surprising rate; ere long, the news came to the world that signals had been received across the Atlantic ocean, and commercial wireless telegraphy became an acknowledged fact. But there were many things to be learned before this point was reached, and we must now trace the development of the idea along this new line.

CHAPTER III.

THE GROUNDED OSCILLATOR.

1. **Development of the Antenna.**—The advent of the grounded oscillating system found many investigators in the field, and each contributed something to the development of the new idea.

Marconi at first considered it important to have a large capacity area on the end of the antenna, after the fashion

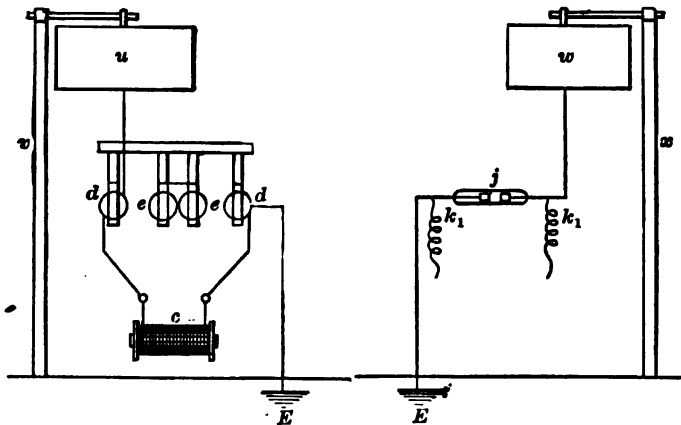

FIG. 73.—Marconi's grounded antenna, with large capacity area. uE is the transmitting antenna, with spark gaps de , ee , ed ; wE , the receiving antenna with coherer, j .

of the Hertzian oscillator, and we find him using the apparatus shown in Fig. 73, with an elevated metallic plate connected to ground through his original Righi spark ap-

paratus.* Guarini employed a similar arrangement in the form of a cage or cone of wires,† hung from a mast (Fig. 74), and many other forms of capacity areas were devised; but it was found that such devices were of com-

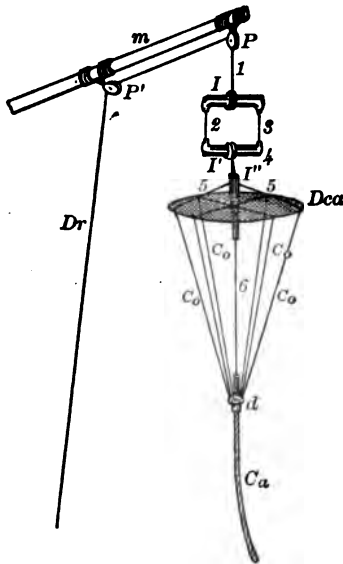

FIG. 74—Guarini's antenna, with a capacity area consisting in a cone of wires, C_o .

paratively limited value, and they gradually gave place to a simple vertical wire, supported by a mast and connected at its lower end to the spark apparatus.

Here we must note the distinction between this form of apparatus and that used by Hertz for the study of waves in wires. (See p. 48.) In the latter case, the connection between the oscillator proper and the wire was through a condenser—a sort of elastic coupling—and the size and capacity of the wire were so small that it exerted comparatively little influence upon

the oscillator, which was thus free to perform its own vibrations and communicate them to the wire. The effect is analogous to that of a large and heavy pendulum connected to a smaller and lighter one through a spring. The natural period of the small pendulum has, of course, a slight effect on the vibrations of the larger one, but

* Marconi, Eng. pat. No. 12,039, June 2, 1896.

† Guarini, in *Elec. Rev.*, v. 51, p. 921, 1902.

the latter predominates and forces the other to swing with it.

So, in Hertz's experiment, the disturbance in the wire was a forced oscillation of the period of the main oscillator, and it was at first suggested that the same might be true in the case of an antenna grounded through a pair of spark balls— that the real seat of the oscillation is in the massive conductors near the spark, and that the antenna plays only a secondary part, as a radiator. But this is not the case. The coupling between the different parts of the apparatus is here a rigid metallic connection, and the system vibrates as a whole with a period determined mainly

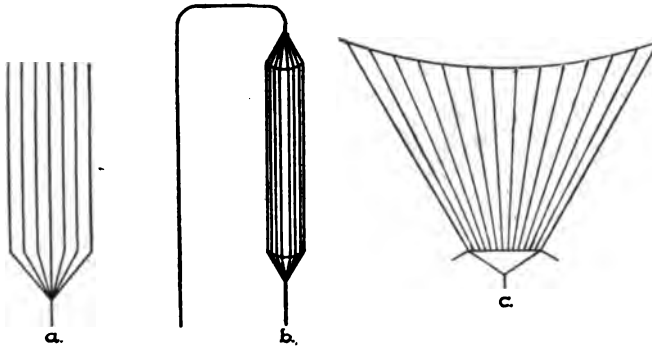

FIG. 75.— Various forms of multiple-wired antennæ:— *a*, Braun's grid; *b*, Slaby's cylinder; *c*, Marconi's fan.

by the height and dimensions of the antenna. For a single wire, the wave-length is equal to four times the height, but where the antenna is loaded with a capacity area, the wave-length is correspondingly increased. It is true that all irregularities in the apparatus have their effect in producing harmonics or inharmonic overtones, and herein lies one disadvantage of the large capacity area. It is much as

if we tried to strengthen and deepen the tone of a piano cord by hanging a weight in the middle. We might succeed to some extent, but the note would be harsh and jarring: the better means is to increase the mass of the whole string uniformly by winding it with wire. This is, in effect, what is done with the antenna: when the energy

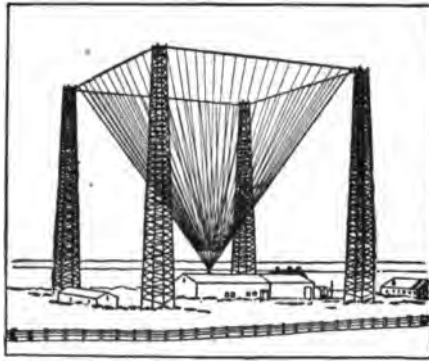

FIG. 76.—Large multiple antenna used by Marconi in trans-atlantic experiments.

of the oscillation of a single wire is not sufficient, the capacity is increased by adding other wires in parallel connection, as shown in Fig. 75. Braun* arranged them as a harp or grid (a); Slaby,† as elements of a cylinder (b); Marconi,‡ as a fan (c); but the form which seems most effective for long-distance installations is that of an inverted cone or pyramid made up of a large number of wires or cables, radiating from a common vertex, from which a connection is made to the spark apparatus. Fig. 76 illus-

* Braun, Eng. pat. No. 12,420. App. June 14, 1899.

† Slaby, *Die Funkentelegraphie*, p. 66.

‡ See Righi-Dessau, *Die Telegraphie ohne Draht*, p. 473.

trates such an antenna as used by Marconi in his transatlantic work.

Not the least advantage of the multiple-wired antenna lies in the fact of its comparatively low resistance. The currents which surge back and forth through the wire, though of short duration, are surprisingly heavy — often many times what would be sufficient to melt the wire if they were continuous. Moreover, as we have already seen, such rapid oscillations are confined to a thin skin on the outside of the wire, and do not penetrate into the interior; hence, the resistance of the wire depends, not upon its area, but on its circumference, and a number of thin wires are much more effective than a single large one of the same cross-section. As a large amount of energy may be wasted in ohmic losses in the wire, this consideration is of no small moment, especially where prolonged oscillations are desired.*

* As a numerical example, take the case of a certain multiple antenna whose constants the writer has carefully measured. It consists in five copper wires, fifty feet long, connected at their lower ends to a single ground wire .10 inch in diameter, and twenty feet long.

The capacity of the antenna to ground is .00022 microfarad, hence its initial charge at a potential of, say 20,000 volts, would be

$$Q = CV = .00022 \times 10^{-6} \times 20,000 = 44 \times 10^{-7} \text{ coulombs.}$$

The frequency, N , of the oscillation is almost exactly 3,000,000 cycles per second; hence the current in the wire during the first swing, before the energy becomes dissipated, would be

$$I = Q \times 4N \times \frac{\pi}{2 \sqrt{2}} = 58 \text{ amps.}$$

The effective thickness of the "skin" at this frequency is about .001 inch, hence the cross-section of wire in the ground connection available for carrying the current is $\pi \times \frac{1}{10} \times \frac{1}{1000} = .0008$ square inches, and the

current density, $\frac{58}{.0008} = 19,000$ amps. per square inch.

The resistance of such a shell of copper is about .0008 ohms per cen-

Still another reason why a large capacity area is of limited utility is found in the considerations outlined on page 125. If we increase the capacity of the antenna without a corresponding increase in its height, the energy of the system is indeed augmented, but the proportion of this energy radiated during each oscillation is diminished, owing to the lower frequency. The *rate* of radiation is not improved by the increased capacity of the oscillator, though the *total energy* given off is greater.* When the coherer is used for receiving, it is the former that counts, and the "whip crack" discharge of a strongly damped radiator is more effective than a prolonged oscillation of the same energy. Of late, however, improved receivers and tuned apparatus have made prolonged oscillations of great value, as will appear in the chapter on syntonistic methods.

2. Other Means of Increasing the Radiation.— Thus far, we have been content with increasing the energy of the oscillations by increasing the capacity of the oscillator. Let us now take up the second means of doing this — by increasing the potential to which it is charged.

timetre, or say .5 ohm for the 20 foot ground wire. Hence the rate of dissipation of energy due to the resistance of the ground connection alone is $I^2R = 58^2 \times .5 = 1700$ watts, or over two horse-power.

During the first oscillation this amounts approximately to 1700 watts $\times \frac{1}{3 \times 10^8}$ sec. = .00057 joules. The total initial energy of the system was $W_0 = \frac{1}{2}CV^2 = \frac{1}{2} \times .00022 \times 10^{-6} \times (20,000)^2 = .044$ joules, hence $\frac{.00057}{.044} = \frac{1}{77}$ th of the entire energy is lost during one oscillation, in the ground connection alone.

If the ground wire were replaced by four smaller wires of the same aggregate cross-section, this loss would be halved.

* See Hertz, *Electric Waves*, trans. by D. E. Jones, p. 150; also, H. M. Macdonald, *Electric Waves*, p. 76.

We have seen (p. 134) that the potential is dependent on the length of the spark, and that this is limited by the ability of the current flowing across the gap to keep the spark hot and afford a path of low resistance for the oscillations. With the increasing capacity of the oscillator this trouble disappears; indeed, with very powerful sparks, the other extreme is reached, and the difficulty is to keep the spark cool. The air in the gap, and also the terminals themselves, get so hot that the gap has not time to recover

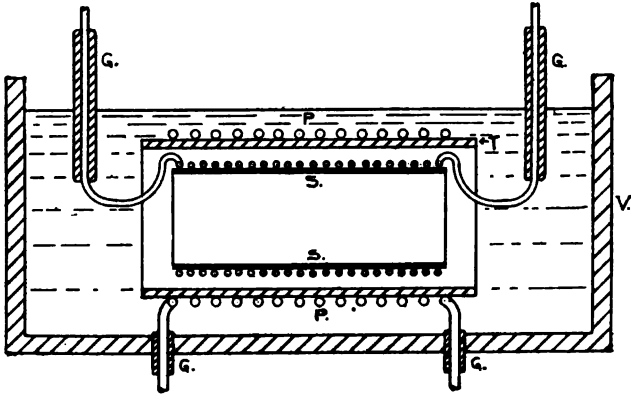

FIG. 77.—A high-frequency transformer, as constructed by Prof. Ellhu Thomson. P is the primary winding, S the secondary, and T a glass tube separating the two. V is a vessel of oil in which the coils are immersed, and G G are glass or rubber bushings for further insulating the terminals.

its insulating character between the successive discharges of the induction coil. Hence, it is impossible to charge the oscillator to a high potential, and the spark degenerates into a continuous flaming arc, quite useless for producing oscillations. This trouble may be avoided by "blowing out" the arc with an air blast or a magnet; but

as it is encountered only with high-power apparatus, we shall pass it by for the present.

In ordinary cases the potential is limited mainly by mechanical considerations, in building and insulating high-voltage apparatus, hence it is often desirable to raise the potential of the antenna above that occurring at the spark-gap.

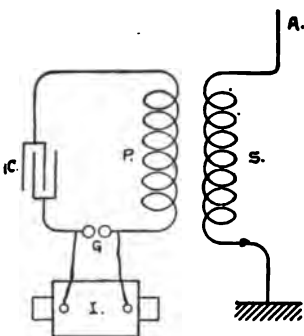

FIG. 78.—Transmitting apparatus with high-frequency transformer. P is the primary of the transformer, whose circuit is closed through the condenser C and spark-gap G; S, the secondary, connected to the antenna A and to ground, and I the induction coil.

The most usual and very effective way of doing this, is by means of an air-core transformer or "Tesla coil." (See Fig. 77.) This is an induction coil or transformer made without iron; both primary and secondary coils are wound with only a few turns of thick wire, and the whole is immersed in oil, to insulate it against the enormous differ-

ences of potential which occur between adjacent parts of the windings.

The primary winding is connected, through a spark-gap, across the terminals of a strongly-insulated condenser, such as a battery of Leyden jars, and the latter is charged by an induction coil or other source of high voltage, and allowed to discharge across the gap. (Fig. 78.) As soon as the spark occurs, oscillations are set up in the primary winding, as in the case of Feddersen's experiments, (p. 22). These, by virtue of their high frequency, have a very powerful inductive effect on the

secondary, and thus it is possible to step up the voltage to a degree far greater than that indicated by the simple ratio of turns of the primary and secondary windings.

One terminal of the secondary winding is connected to ground and the other to the antenna, which is thus charged to a much higher potential than that which occurs at the spark-gap.

To obtain the best results, the two circuits should be "tuned," so that they both perform free oscillations of the same period; but as this subject will be treated more fully in the chapter on Selective Signaling, we shall postpone consideration of it until then.

3. The Induction Coil.—The development of the antenna, and its increasing size and capacity, brought with them the demand for more powerful apparatus for charging the oscillator. With the small oscillators of Hertz and his followers, an ordinary induction coil was quite sufficient, but the new devices imposed new requirements which the old-fashioned coils are inadequate to meet.

The standard induction coil of the laboratory grew out of the demand for long sparks and high voltages, and a coil was rated according to the length of spark it could generate, with little regard to other considerations. The result is a coil with a slender iron core and primary, surrounded by a prodigious amount of secondary wire of the smallest size that can be wound and handled. This is precisely what is *not* wanted for wireless telegraph work.

We have seen that very long sparks are not desirable; a one-inch spark is ample for sending messages a hundred miles or more with a plain antenna, and even for long-distance work the tendency is to use short sparks and increase the radiation by other means. The attempt to

use the old standard coils for such service is much like trying to drive a steam engine by liquid air, let out of a pressure cylinder through a tiny orifice. The pressure is there, and, it may be, the energy; but by the time the air reaches the piston, most of its power is lost. So a coil with a long and fine secondary, of enormous self-induction and resistance, is sluggish in its action — it takes a considerable fraction of a second to give up its energy. After the antenna is once charged and the spark occurs, all the energy remaining in the coil is wasted, and goes only to heating the air-gap and its spark-terminals, and spoiling its insulation for the next spark.

What is wanted is a coil which gives a large amount of energy at a moderate voltage, and yields it up quickly; giving the pendulum, as it were, a quick, powerful shove and letting go. Now the energy available for each discharge is all stored in the magnetized iron core before the primary circuit is broken, and is thence transferred, through the secondary, to the antenna, with greater or less rapidity, according to the resistance and inductance of the circuit and the capacity of the antenna.

The outcome of these various considerations is a coil having a core of ample cross-section and moderate length, with a secondary of comparatively few turns of coarse wire, so wound as to secure the maximum effect from the magnetism of the core. Such a coil will give a clean, snappy spark at a high rate of interruption, where another having many times the weight of wire would refuse to work above a dozen breaks per second. Any attempt to increase the speed of the break would result in a hot, flaming arc, wasting energy, and useless for producing radiation.

The influence of the rate of interruption on the possible speed of signaling is too manifest to require comment.

4. High-power Generators.—Where a still greater supply of power is required, the induction coil is often replaced by a high-voltage transformer, operated by an alternating current generator. This arrangement has many advantages, not least of which is the doing away with the primary interrupter or vibrator — an apparatus

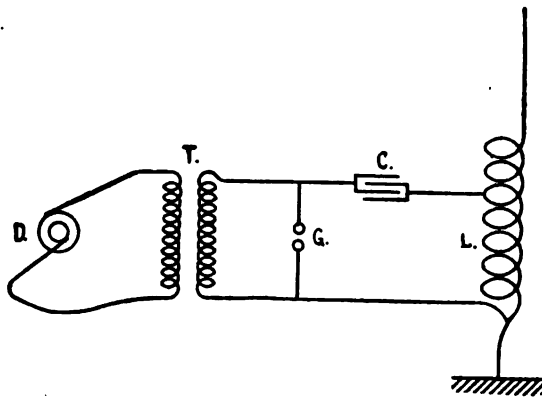

FIG. 79.—Transmitting apparatus fed by an A-C generator D, whose voltage is stepped up by a transformer T. A condenser, C, of large capacity compared to the antenna, is connected in a local circuit, C G L, coupled to the antenna through the inductance coil L.

which gives much trouble when called upon to handle any considerable amount of power, notwithstanding the many ingenious shapes that it has taken in the process of adaptation to various classes of work.

A typical form of this class of transmitters is that used by the DeForest Wireless Telegraph Co. (See Fig. 79.) The voltage of an ordinary commercial alternator is stepped up to, say, 25,000 volts by an oil-insulated trans-

former, whose secondary is connected to the terminals of the spark-gap. The spark-gap is not included directly in the antenna circuit, for this has not sufficient capacity to absorb all the energy of the alternator at the voltage used; but the current is fed into a condenser of larger capacity, included in a branch circuit containing an inductance, which is also made part of the antenna circuit. The two circuits thus interconnected vibrate together, the energy of the condenser being fed to the antenna as the energy of the latter is radiated. Usually the antenna circuit must contain an additional inductance to make its period the same as that of the branch circuit, its capacity being less. It is convenient to combine the two inductances in one coil having several terminals to facilitate tuning, as shown in the figure, in which case the apparatus approaches very closely the arrangement described on page 148, where a transformer was used to couple the closed oscillating circuit to the antenna. Indeed this doubly-connected coil is practically a transformer, in which the same wire plays the part of both primary and secondary windings.

With such a high-power generator, the energy that may be applied to the oscillator is practically unlimited, and the ability of the latter to receive it may be increased almost indefinitely by the use of condensers of sufficient size. The trouble comes in handling the energy at the spark-gap, and causing the discharge to maintain its oscillatory character, despite the tendency to heat and form an arc. Air-blasts, magnetic blow-outs, and multiple spark-gaps have all been used with varying degrees of success, in the effort to keep the spark cool.

A particularly effective device due to Prof. Fleming* is shown in Fig. 80. An alternating-current generator of, say, 25 kw. capacity feeds a step-up transformer, T_0 , by which its voltage is raised to 20,000 v. The shaft of the alternator carries, or is geared to, a radial arm whose end passes close to two metallic sectors, set at diametrically opposite points. The arm is set in such a position that it comes opposite to one of the sectors, B_0 , when the voltage is

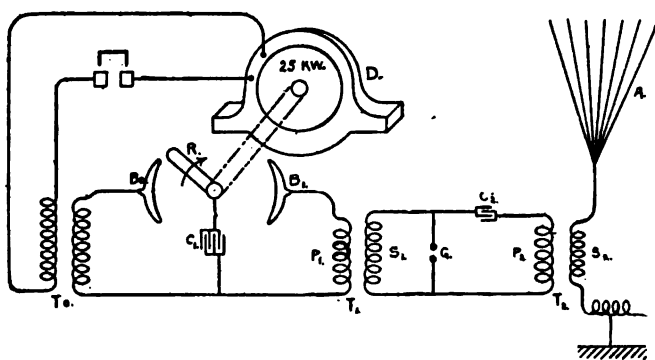

FIG. 80.—High-power generator of Prof. Fleming. D is an alternator, feeding a step-up transformer T_0 . R is a rotating arm driven by the alternator shaft, and passing close to the sectors B_0 B_1 . T_1 and T_2 are air-core transformers, C_1 and C_2 the primary and secondary condensers, G and air-gap, and A the antenna. The low-frequency oscillations of the primary oscillating circuit, $C_1RB_1P_1$, excite the secondary oscillating circuit, C_2GP_2 , whose high-frequency oscillations charge the antenna A.

a maximum, and a spark leaping across charges a condenser of large capacity, C_1 , to practically the full voltage of the transformer. When the arm has made a half revolution and reached a position opposite the second sector, P_1 , an

* See Eng. pat. No. 18,865. Application filed Oct. 22, 1900.

other spark occurs, whereby the condenser is discharged through the primary of an air-core transformer, T_1 , and oscillations are produced which are again stepped-up to a still higher voltage.

As the capacity of the condenser C_1 must be very large to absorb the whole output of the generator, these oscillations are of comparatively low frequency — say 10,000 per second — too slow to be used directly for radiation by an antenna; so they are employed as a secondary source of power, to excite a secondary oscillating system, consisting in a spark-gap, G , a condenser, C_2 , and a second air-core transformer, T_2 , whose secondary is connected to the antenna and to ground. When the condenser C_1 is charged to a potential high enough to break down the air-gap, a powerful spark occurs, and a new set of oscillations is started with a high frequency, depending on the capacity and inductance of this second circuit and independent of the frequency of the primary oscillation. This capacity and inductance are made small, so that the secondary circuit may be tuned to the natural period of the antenna, and thus the maximum efficiency of radiation be secured.

The energy of this secondary oscillation is much greater than it could be made by any of the ordinary means. We shall see (p. 215) that the secondary voltage of an oscillation transformer such as T_1 may be much higher than that which would be indicated by the simple ratio of turns, for the ratio of the capacities, $C_1 : C_2$, is also an important factor. Thus, notwithstanding the small capacity of the condenser C_2 (.02 microfarad as against 0.5 mf. for C_1 , in a case cited by Prof. Fleming), the increased voltage enables it to absorb most of the energy of the latter, and make it effective in radiation.

This apparatus is used by Marconi for transatlantic work. Its radiation has the advantage, not only of great energy, but also of small damping and correspondingly small intensity. Thus its signals may be detected by an apparatus two thousand miles away, properly tuned to receive them, while passing unnoticed by the untuned instruments on vessels in between. We shall see more of this in Chapter VI.

CHAPTER IV.

PROPAGATION OF GROUNDED WAVES.

1. **Three Hypotheses Suggested.**—We have seen that the waves emitted by a Hertzian oscillator are polarized transverse vibrations, of essentially the same nature as light, but enormously greater wave-length; that they travel ordinarily in straight lines, but are subject to reflection, refraction, diffraction, etc., precisely like ordinary light. Are the radiations of a grounded antenna of the same nature, and subject to the same laws, or have they some peculiar properties which set them apart from the free Hertzian waves which we have been considering?

The answer to this question is of great practical importance to the wireless telegrapher, as it will go a long way toward determining his ability to surmount obstacles in the path of his waves. To dodge a little hill or a group of houses is a simple matter of diffraction when the wave-length is great, but to cross a mountain range or the hill of water due to the curvature of the earth is quite another matter. The curvature of the earth is a considerable factor, even in comparatively short transmissions — a distance of forty miles between stations being sufficient to put the highest masts below the horizon — yet it is now an every-day matter to send signals for hundreds or even thousands of miles. How can we explain this?

Three hypotheses have been offered to explain the propagation of signals from an antenna:—

1st. That they are free waves in the ether, exactly like those studied by Hertz, except for their wave-length.

2d. That ether waves have little to do with the case, except to waste energy by shooting into space; but that the signals are transmitted by alternating currents in the earth or sea.

3d. That there are electric waves of a peculiar character, which glide over the conducting surface, following its curves as a rain drop follows a window-pane.

None of these ideas are absurd, and we must call upon experimental facts to decide between them.

2. The Free-Wave Hypothesis.—Take first the hypothesis of free waves. There are four ways in which such a wave may pass an obstacle: by passing through it, by diffraction around it, by reflection or refraction by surrounding objects. The first involves the conductivity of the obstacle—we know that a conductor is opaque to the waves, while a dielectric is transparent. Now, sea-water, though a good conductor for slowly-varying currents, is quite transparent to light; and even with waves a million times longer, such as are produced by the smaller Hertzian oscillators, it acts as a more or less perfect dielectric. (See p. 83.) But the waves used in wireless telegraphy, at a frequency of a million cycles per second, are several hundred times longer still, and Prof. J. J. Thomson has shown conclusively that, at these frequencies, sea water is a good conductor, and hence quite opaque to such waves.* So, if we are to accept the “free-wave” hypothesis, we must find

* See J. J. Thomson, *Proc. Roy. Soc.* 45, p. 269, 1899.

a way to get *around* the surface of the ocean, not through it.

Diffraction has been suggested, but we must remember that the amount of deviation depends upon the relation of the wave-length to the sharpness of the diffracting edge. M. Gouy, in his experiments on the diffraction of light by the edge of a very keen razor, obtained remarkable deviations (p. 96); but here the thickness of the edge was comparable to the wave-length of light. The waves that we are dealing with are to the earth as light waves are to a sphere one inch in diameter, and it is difficult to conceive of such an extreme case of diffraction in the light of our present knowledge.

Again, diffuse reflection may be considered, as we see it in the afterglow when the sun has sunk below the horizon. But here, the sun's rays are reflected from material particles, large in proportion to the wave-length, suspended in the air. As the diameter of the particles approaches the wave-length of the light, the reflection becomes less and less perfect. The longer waves are naturally the first to be affected; thus, on a perfectly clear day when the suspended particles are very minute, the longer red and yellow rays are scarcely reflected at all, and the sky looks blue, on account of the preponderance of the shorter waves.

Where are the material bodies in the upper air large enough to reflect waves 1,000 feet long? Clouds will not do, for a fog-bank is found to be quite transparent. The water which composes the fog and clouds, even if itself a conductor, is concentrated in minute globules separated by insulating air, so the cloud as a whole acts as a good dielectric. Some think that the rarified upper strata of the air are sufficiently good conductors to reflect the waves,

as the sound of a distant thunder-clap is drawn out into a long roar, but this remains to be proved, and the trend of experimental evidence is against it.

Then there is refraction. But atmospheric refraction is not sufficient to carry light any considerable distance around the globe, and the specific inductive capacity of air is not large enough to indicate any great difference in the index of refraction for long electric waves. (See p. 79.)

Finally we have the experimental fact that the transmission of waves from a free oscillator has never been successful over long distances, notwithstanding the many attempts at concentrating them by mirrors, etc., whereas the radiations from a grounded antenna travel indefinitely over the sea with no appreciable loss in intensity beyond that which is accounted for by the attenuation of the waves through spreading out over constantly-widening areas. The free-wave hypothesis does not account for this.

3. The Alternating-Current Hypothesis.

— Consider now the second explanation: that alternating currents are set up in the earth, flowing in and out of the antenna, and that these currents travel through the ground, themselves giving rise to the signal at the receiving station without the aid of ether waves.

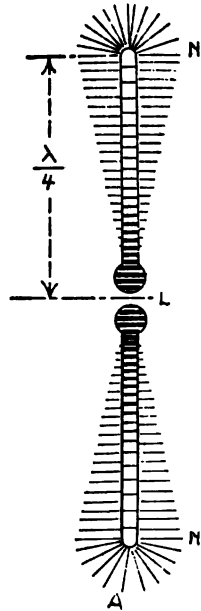

FIG. 81.—Vibration of a free oscillator. Radiating lines show distribution of potential; shading, the intensity of current. NN, nodes, L, loop, A, ground.

That such currents exist is undeniable. We may look upon a grounded antenna as half of a Hertzian oscillator, such as is shown in Fig. 81. We have learned that the ends of an oscillator are nodal points, where the potential varies but there is no current, while at the spark-gap in the middle there is a loop, where currents surge back and forth but there is no change of potential. If we take away the lower half of the oscillator and in its place put an infinite

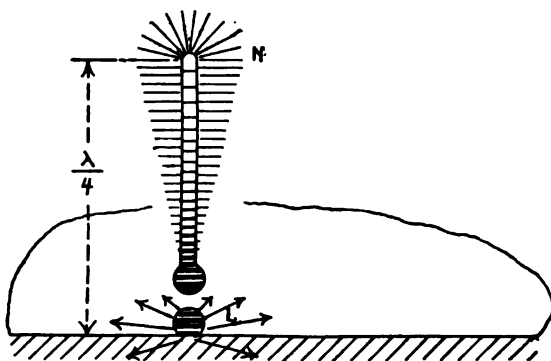

FIG. 82.—Vibration of grounded oscillator. Distribution of potential and current as in Fig. 81, but currents spread out in conducting plane.

conducting plane, the oscillations will go on as before; the point where the oscillator meets the plane will still be a loop, and the currents will surge in and out, losing themselves in the conducting surface. (Fig. 82.)

The same is true of a sonorous tube containing a vibrating column of air. (Fig. 83.) If the tube be closed at both ends, the vibrations will surge back and forth with a node at each end and a loop in the middle. If we cut the tube in two, leaving the cut ends open, each half will

vibrate precisely as before, with a node at the closed end and a loop at the open one, and currents of air will rush in and out of the open end. (Fig. 84.)

But are the currents which radiate in all directions from the oscillator sufficient to account for the signals received at a distance? Unquestionably there is also a large

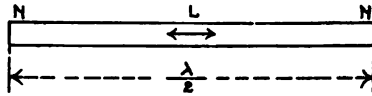

FIG. 83.—Vibration of air column in tube closed at both ends. Nodes at ends, loop in middle.

amount of energy given out in ether waves, for a receiver placed near the oscillator is affected, whether it be grounded or not. If these ether waves travel outward in straight lines, we should expect the intensity of the signal to fall off rapidly when the distance becomes so great that the earth cuts off the direct radiation; but this is not the

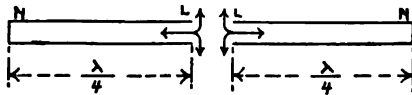

FIG. 84.—The same tube cut in two, with ends left open. Each half vibrates as before, and air currents rush in and out of the open ends.

case: the attenuation follows the same law, however great the distance.

Again, if a coherer be placed in a hole in the ground, it will operate when uncovered; but if the hole be filled with earth, the oscillations produce no effect.*

* See Poincaré. *Notice sur la Télégraphie sans Fil*, Ann. du Bur. des Long. 1902, Notice A, p. 12.

We must look for something more than earth currents to explain the phenomena.

Yet there is evidence that the conductivity of the surface over which the radiations pass has a marked effect on their attenuation. The transmission is very much better over sea than over land, and some kinds of land are better than others: dry, sandy ground gives very poor trans-

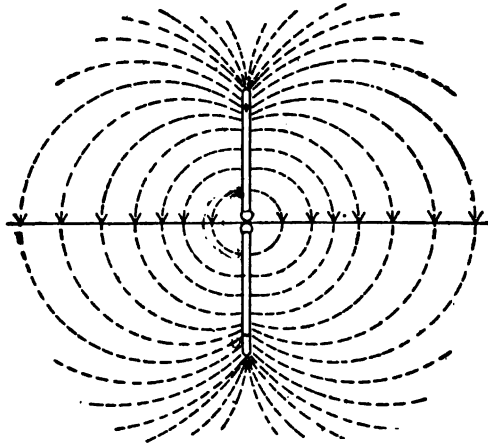

FIG. 85.—The electrostatic field about a charged Hertzian oscillator just before the air-gap breaks down and the oscillations commence. The "lines of force" indicate the direction of the displacement in the ether, and hence the stress or "electric force" which accompanies it. Each line may be considered the axis of a Faraday tube of induction.

mission, while a rich, fertile soil is much better. Again, the same line may work better at one time than at another: when the soil is moist the transmission is good, but when it is dry or frozen the signals are much weaker. In short, a good conducting surface is favorable to the transmission of signals, while a poor conducting surface is not. Thus we are forced to the conclusion that, although the dis-

turbance really has its seat in the ether, it is very closely connected with the surface over which it glides.

4. Propagation of Free Waves.—Let us now look again at the principles which underlie etheric disturbances, and see if there is any way in which they may be caused to follow a conducting surface.

First we must review the action of an ordinary Hertzian oscillator.

Take, for simplicity, a straight wire, interrupted in the middle by a spark-gap. (Fig. 85.) Suppose the two knobs which constitute the spark-gap to be suddenly connected to a source of constant high potential, not quite sufficient to break down the air-gap. A current flows from the knobs toward the ends of the apparatus, and continues until both conductors are completely charged. But the current does not stop at the surface of the conductors; it takes the form of a system of displacement currents, flowing out through the ether, and forming loops from end to end of the oscillator, thus completing the circuit. While these currents are flowing the ether is being strained, and when finally the condition of equilibrium is reached and the currents cease to flow, the whole medium is in a state of electrostatic stress. If we explore the field with a small electrified body and plot, from point to point, the direction in which it tends to move, we get a series of curves such as are shown in the figure. These "lines of electric force," we should remember, represent the displacement in the ether, whose behavior is analogous to that of an elastic solid; it tends to move back to the position of equilibrium with a force proportional to the displacement.

To give the idea a little more concrete form, let us

imagine, as Faraday did, that each of these lines is the axis of a "tube of force," or, more accurately, a "tube of induction," whose cross-section varies from place to place, so that the whole electrostatic field is filled with these tubes, starting at one side of the oscillator and ending at the other.

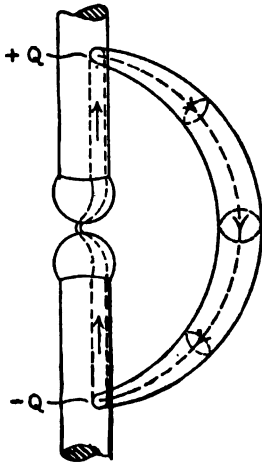

FIG. 86.—A portion of the oscillator, FIG. 85, enlarged, showing a single Faraday tube. The tube terminates in opposite charges, +Q and -Q, on the surface, equal to the integral value of the current which supplied these charges, and also to the induction, or "electric flux" across any section of the tube.*

Each tube may thus be considered, apart from the others, as a closed volume in which the displacement has occurred, forming part of the circuit through the conductor. The total induction or "electric flux" (as we may call it on account of its analogy to a magnetic flux), across any section of this tube, is constant, and equal to the total integral current which has flowed in that part of the conductor which completes its circuit—that is, to the charge on the surface of the conductor in which the

tube terminates.* (See Fig. 86.)

Here we must guard against a too literal interpretation of the figure, and remember that the assumption of the

* Owing to the unfortunate choice of units in our C. G. S. system, it is necessary to introduce here the constant factor 4π , but this does not affect the principle involved. With a suitable choice of units the factor would disappear.

Faraday tubes is simply an arbitrary convention, which puts into concrete form the broad principles which we are studying. The mathematical analysis from which these principles are derived involves no such arbitrary assumptions — they are introduced simply to give tangible form to the unknown something represented by Maxwell's equations, so that we may trace its actions and determine its properties.

With this understanding we may go a step farther, and assume that the tubes have an individual existence, apart from the space which they embrace; that they may travel from place to place; and that any change in the intensity of an electrostatic field is due to the motion or distortion of the tubes, which are themselves indestructible; and each unit tube is of constant strength, measured by a unit positive electrical charge at one end and a unit negative charge at the other. Thus an open-ended tube always begins and ends on matter; though, under certain circumstances, as we shall see presently, a portion of a tube may form a loop, which becomes detached and goes off into space, closed on itself.

This concrete conception of the tubes as individuals is similar to the consideration of vortex motion in fluids. A vortex ring, for instance, is simply a state of disturbance in the air; but if we look upon it as a concrete entity, we find that it possesses inertia, elasticity, etc., and we see that two rings may collide and rebound, and may exhibit many other properties of material bodies. Furthermore, a vortex filament must either be closed on itself or must end at the bounding surface of the fluid, just as our Faraday tubes do.

So also our Faraday tubes possess certain peculiar properties, and a complete mathematical analysis of the subject shows that nearly all, if not all, electrical phenomena may be explained by a consideration of their actions.

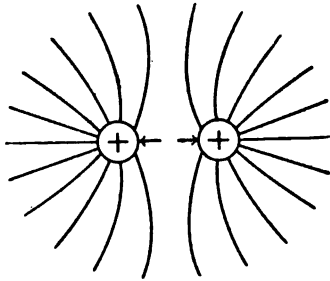

FIG. 87.—Illustrating the mutual repulsion of the similar Faraday tubes emanating from similarly charged bodies. *i. e.*, the tendency of the tubes to expand laterally.

In the first place, they possess inertia. Not only does a tube represent a supply of potential energy, due to the strained condition of the ether which it embraces, but it may also possess kinetic energy due to its velocity. This kinetic energy is closely allied to the energy of the magnetic field, for a *Faraday tube, when in motion, is always accompanied by a magnetic force perpendicular to the tube and to its direction of motion*, and this magnetic force, as we already know, represents a stock of kinetic energy.

Furthermore, the tubes act and react upon each other; similar tubes; *i. e.*, tubes of the same sign, repel each other, while opposite tubes attract each other; and each tube has a tendency to contract in the direction of its length. Thus, two similarly charged spheres are mutually repellant, and the similar tubes emitted by each radiate into space (Fig. 87), while oppositely charged conductors are drawn together, by virtue of the tension of the tubes which spring across from one to the other.* (Fig. 88.)

*For a more complete discussion of the properties of Faraday tubes, see J. J. Thomson, *Recent Researches in Electricity and Magnetism*, Chap. I.

Now let us apply these principles to our oscillator. We have the conductors charged, and the Faraday tubes forming bridges through space from one to the other. Now let the air-gap break down and a sudden current rush across from conductor to conductor. This means that the opposite charges on the two conductors move toward each other, carrying with them the opposite ends of their Faraday tubes. This gives the tubes nearest to the oscillator the opportunity to contract and draw up to the conductors, leaving a vacant space, as it were, into which the longer tubes are forced vertically by the pressure of others outside; or, what amounts to the same thing, the opposite sides of the loops are drawn together by their mutual attraction, so that the tubes take a pear-shape, and the sides finally meet and coalesce. The outer loops of the tubes then separate and go off by themselves, repelled by the inner portions, which now draw up to the oscillator until their ends meet. But the tubes do not disappear and go out of existence when their ends come together — their inertia carries them on, their terminal charges separate, and they again expand until the conductors are charged once more with reversed polarities. Then the same thing is repeated, the tubes again contract, and again a series of closed loops are sent off, carrying with them a part of the energy of the oscillation.

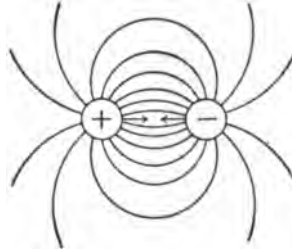

FIG. 88.—Oppositely charged bodies attract each other: i. e., the Faraday tubes tend to contract in the axial direction.

In Figs. 89 to 92, we may trace the progress of the oscillation through a complete cycle, at intervals of an

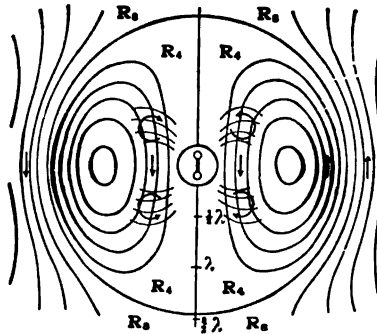

FIG. 89.—The field of electric force about a rectilinear oscillation (after Hertz) at the moment $t = 0$ (conductors discharged). The oscillator is shown in the center, drawn to scale, and each line of the field represents the axis of a unit Faraday tube. The closed loops indicate a detached wave just starting outward.

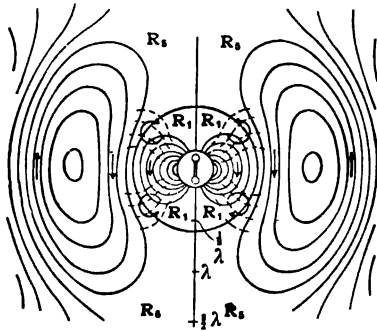

FIG. 90.—The field about the oscillator after an eighth period ($t = \frac{1}{4}T$). The conductors are becoming charged and Faraday tubes are spreading out from them, filling the region within the circle R_1 .

eighth period, as worked out mathematically by Hertz;*

* See Hertz, *Electric Waves*, Eng. trans. p. 141 et seq.

the lines of force in the diagrams representing the axes of our unit Faraday tubes. Fig. 89 represents the state of

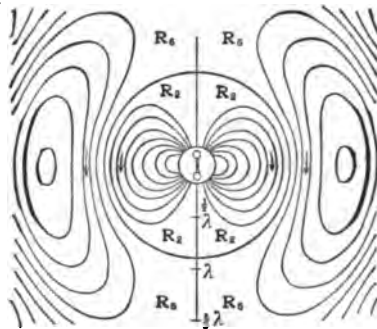

FIG. 91.— For time $t = \frac{1}{4} T$. The conductors are now fully charged, the circle has enlarged to R_2 , and the tubes have expanded to fill it.

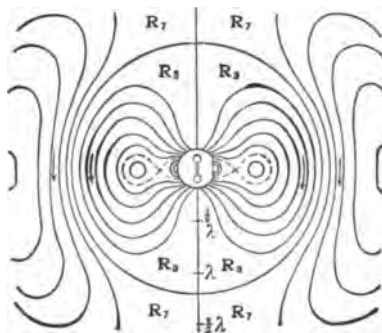

FIG. 92.— For $t = \frac{3}{4} T$. The conductors are discharging, the loops are expanding and flattening, and the wave is beginning to be detached. When t increases to $\frac{1}{2} T$, the wave will take the form shown in FIG. 89. (In Hertz's notation, λ denotes the half wave-length.)

affairs when the conductors are completely discharged, and all the energy of the oscillation is in the form of current — no tubes of force proceed from the oscillator. Fig. 90

shows the conditions an eighth-period later, and the lines within the circle represent the growing electrostatic field. In Fig. 91 the circle has expanded, and the lines have spread out to fill it: the current is now zero, and the whole energy of the oscillation is represented by the electrostatic field within the circle. In Fig. 92 the current has reversed, and the tubes begin to contract into a pear-shape — already one of them has formed a detached loop, which is commencing its outward journey, while the inner portion is shrinking back to the oscillator.

We now reach the end of a half-period, and the conditions are the same as they were at the beginning, though reversed, and if we reverse the arrows which show the direction of the displacement in the ether, Fig. 89 will correctly represent the new state of affairs: the Faraday tubes have all withdrawn into the oscillator, leaving behind a number of detached loops, which are expanding through their mutual repulsion and beginning to travel outward. In Fig. 90 the reversed set of tubes are beginning to expand, forcing the detached wave outward, and flattening it on its inner side. So it travels on with the velocity of light, followed by another and another, each expanding laterally into a crescent-shape as it goes, until finally, at a great distance from the oscillator, the tubes of induction form almost perfect semicircles with their common center at the oscillator; in other words, a spherical wave-front.

Thus far we have considered only the electrostatic field which goes with the waves. How about the magnetic field? This follows simply from the law that a moving Faraday tube always produces a magnetic force perpendicular to itself and to its direction of motion. Thus the lines of magnetic force will form closed circles with their centers in

the axis of the oscillator, expanding as the waves travel outward, always remaining perpendicular to the Faraday tubes and forming parallels of a series of concentric spheres of which the Faraday tubes, or electrostatic lines, are the meridians. (See also p. 76.) The energy of the wave is thus half electrostatic and half magnetic, just as in a water wave the energy is part potential, due to the elevation of the crest and the depression of the trough, and part kinetic, due to the outward motion of these crests and troughs. (See p. 122.)

This distribution of magnetic force does not apply to the region immediately surrounding the oscillator, for here the magnetic field due to the currents in the oscillator itself is superimposed on that due to the expanding wave: for example, when the conductors are discharged and the tubes have all withdrawn into the oscillator (Fig. 89), the magnetic force is not zero, but is very large — the current is a maximum, and the whole energy of the oscillation is in the magnetic field close about the oscillator. But these limiting conditions do not concern us here, as we only have to deal with the waves at a considerable distance from their source, where the effects of direct induction have given place to pure radiation. Here there is a real transfer of energy in the direction of propagation, as in the case of progressive water waves, where elevation and velocity occur together; but near the oscillator the conditions approach more nearly those of stationary waves in a closed vessel, where elevation alternates with velocity, and the energy simply oscillates between the potential and kinetic forms without being transmitted through space.*

* This transition from stationary to progressive waves may be illustrated by the hydraulic model, Fig. 65, p. 122. Directly over the dis-

These are free waves in space — the peculiar discovery of Hertz — traveling outward with the velocity of light in ever-expanding spheres. The direction of propagation must always be perpendicular to the wave-front, *i. e.*, to the plane of the Faraday tubes and the lines of magnetic force, hence the disturbance travels radially in straight lines, like light. Indeed we know that it is practically polarized light of immensely magnified wave-length.

5. Propagation of Guided Waves.— Now suppose the whole system to be divided into two symmetrical halves by an infinite sheet of conducting material, passing through the center of the oscillator. (See Fig. 85.) This plane, being everywhere equidistant from the oppositely charged ends of the oscillator, is a plane of zero potential; as all the Faraday tubes cut it at right angles, no electromotive forces are induced in it; the opposite electrical charges on its opposite faces due to the impinging of the Faraday tubes, being infinitely close together, neutralize each other, and the resultant is zero — indeed, everything goes on as if the plane were not there.

Again, suppose the lower half of the system to be removed. The oscillator will vibrate as before (see p. 160); currents will surge into and out of the plane, *i. e.*, the Fara-

charge pipe the crest simply rises and falls, velocity alternating with elevation. To use the familiar alternating current terminology, the velocity and pressure are in quadrature, and the vibration is "wattless," so to speak. The wave is stationary. At a distance from the source the crests move outward and the troughs move inward, the velocity and pressure are in phase, and power is transmitted by the progressive wave. So, near the oscillator the electric force and the magnetic force are in quadrature, and represent energy at rest — the inherent energy of the oscillation —; at a distance they are in phase, and represent a transmission of power.

day tubes which now terminate in the plane carry their charges to and from the oscillator as they move in and out; the tubes which are detached travel outward as before, carrying their charges with them. These moving charges constitute a series of alternating conduction currents in the plane,* completing the circuits of the displacement currents in the dielectric which, we know, accompany the moving Faraday tubes. Thus the half-waves travel on, precisely as if the other halves were present.

Now suppose the conducting sheet to be curved. A perfect conductor is, by definition, one in which only vanishingly small electric forces can exist. Hence there can be no tangential component of the electric force, and the tubes of induction must always be perpendicular to the surface. If, then, the surface be curved, the Faraday tubes must accommodate themselves to the curvature, and the wave, whose direction of propagation is always perpendicular to the tubes, will follow the surface, as illustrated in Fig. 93.

If this is not evident, imagine for the moment that the tubes do impinge obliquely on the curved sheet. This involves the production of an electromotive force in the surface, hence a current will flow. This means that the charges at the ends of the tubes are moving with a velocity different from that due to the normal progress of the wave, and thus the grounded ends of the tubes move more or

* The experimental proof of the equivalence of a moving charge to an electric current was one of the masterpieces of the late Prof. Henry Rowland. He showed that a rapidly rotating disc carrying charged conductors on its periphery caused a deflection of a sensitive magnetic needle suspended near by, and that the magnitude of the effect agreed substantially with that demanded by the theory. The effect is very minute, and has escaped other less skillful experimenters.

less rapidly than their upper parts, according to the direction of the curvature, until they again become normal to the surface and the currents cease. This explains the observed fact that the currents in the earth are greater when the wave travels up or down hill than when it follows a level surface.

If the guiding surface is not a perfect conductor, which is actually the case in practice, an electromotive force is

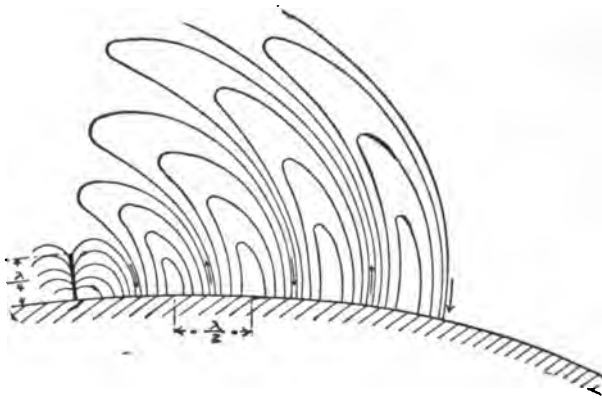

FIG. 93.—Propagation of grounded waves from an antenna over a curved surface.

necessary to overcome the ohmic resistance and produce the alternating currents in the surface. Hence the Faraday tubes are distorted and strike the surface obliquely, giving up part of their energy to supply the ohmic losses in the surface. Thus we see why the conductivity of the surface has such an important influence on the attenuation of the waves.

Where the conductivity is perfect the attenuation de-

pends simply upon the distance from the source. The number of tubes in each wave remains constant as the wave expands, but the cross-section of each tube continually increases to fill the space at its disposal — not in a radial direction, for the waves follow each other at constant velocity and hence the distance between them is always the same — but in a direction parallel to the wave-front. The cross-section of a tube thus increases directly as the distance from the source. Now the “displacement,” or induction per unit area, in the ether contained within a tube is inversely proportional to the cross-section of the tube, for the total induction, or electric flux, across any cross-section is constant; hence the electric force, which is proportional to the displacement, varies inversely as the distance from the source, and the energy of the field, inversely as the square of the distance. This is the result given on page 129.

In a similar way we may explain Hertz's discovery that most of the energy is concentrated near the equatorial plane, instead of being distributed equally in all directions as in the case of ordinary light.* Only a few of the Faraday tubes stretch out to any considerable distance from this plane — most of them bend around and reverse their direction within a comparatively short distance, as shown in Fig. 93. Hence those that do extend their crescent-shaped loops toward the poles have proportionately more space to fill, and their energy is distributed and attenuated. To reproduce the uniform distribution of ordinary light, we should need an infinite number of oscillators, oriented in all directions.

* *Electric Waves*, Eng. trans., p. 143.

Finally, we see that each of the three hypotheses we have considered has some foundation in fact, though the last is the only one that is adequate to explain all the phenomena: in short, the grounded waves are really of the same essential character as free Hertzian waves, and they are accompanied by alternating currents in the guiding plane, but they are distinguished by their inseparable connection with the surface over which they glide. If we imagine the extreme case where the guiding surface is contracted and bent into a long, narrow cylinder, we shall have the propagation along a wire discussed in Chapter VI of Part One. In this case the wave becomes a plane transverse one, whose amplitude does not diminish with increasing distance, except as the energy is wasted in ohmic and other losses.

6. Effect of Daylight on Wave Transmission.—An interesting phenomenon has been observed by Marconi in his experiments with long-distance transmission.* It is found that, under similar conditions, the signals transmitted between two stations are much stronger at night than in the daytime. The high-power station at Poldhu, for example, may be sending out signals which are easily received by a vessel in midocean, while it is night; but as soon as the sun rises over England the intensity of the signals begins to wane, and in full daylight the difference is very marked.

This striking effect has not yet been thoroughly explained, but it calls up many interesting suggestions. Hertz observed (p. 36) that a spark-gap breaks down much more readily when exposed to ultra-violet light from

* See paper before Royal Society, June 12, 1902.

another spark than it does when not so exposed. This may be explained on the hypothesis, which is daily gaining weight through the experiments of many noted investigators, that ultra-violet light has the power of "ionizing" a gas, or splitting up some of its molecules into smaller bodies, or "ions." The ions are not electrically neutral, as normal molecules or atoms are, but carry equal and opposite electrical charges. These charges, before their separation, neutralized each other and so were unobserved, but now they are free to move under the influence of any electrostatic stress.

An analogous effect occurs in an electrolytic cell. Pure water does not conduct electricity; but if it contain in solution a trace of hydrochloric acid, for example, it conducts readily. In the act of dissolving, some of the molecules of acid are supposed to split up into oppositely charged ions, or electrons, and these, by their motion, constitute a current through the solution.

If now we postulate a similar splitting up of the atoms of air into oppositely charged ions,* under the influence of sunlight, we may explain the anomalous attenuation of electromagnetic waves. Under the influence of the electrostatic stresses which accompany the waves, the oppositely charged ions will move in opposite directions, and by their motion will produce what is practically a conduction current, or more strictly a convection current, in the air, just as the ions of electrolysis are the

* J. J. Thomson has shown that the cathode discharge of a vacuum tube consists in negatively-charged "corpuscles," whose mass is a small fraction of that of a hydrogen atom, and similar bodies occur in free gases. See J. J. Thomson, *Proc. Roy. Inst.*, 1901, p. 574; also *Phil. Mag.*, March, 1903.

seat of the current in an electrolyte. Such currents will fritter away the energy of the wave, in the same way as the convection of heat from the warm compressed portions of a sound wave to the cooler rarified portions results in a dissipation of energy, and an attenuation of the sound.

This explanation should not be taken as final, but it is at least suggestive, and in harmony with the latest views regarding the ionization of gases.

CHAPTER V.

THE RECEIVING APPARATUS.

1. Detectors Classified.— Since Chapter V of Part One was written by M. Poincaré, detectors of electric waves have appeared in such a variety of forms that it is difficult to select from among them those that may be described in one short chapter. We shall have to be content with a classification according to their principles of operation, and the description of a few typical forms from each class.

The detectors now in use may be separated roughly into five groups:

- 1st. The Microphonic.
- 2d. The Mechanical.
- 3d. The Thermal.
- 4th. The Electrolytic.
- 5th. The Magnetic.

These groups are not always sharply defined, nor do they include all possible forms of detectors, but the arrangement is a convenient one, and covers all the principal types that are of practical value.

2. Microphonic Detectors.*— This class includes all detectors of the coherer type, which Marconi has broadly and tersely defined as “a sensitive imperfect contact.”†

It has long been known that two conducting surfaces in

* The word “Microphonic” is rather a misnomer as applied to a detector of *electric waves*; but as it suggests the principle involved, it is a convenient term, in the absence of a better one.

† Marconi, Eng. pat. No. 12,039, June 2, 1896.

light contact, such as a carbon point resting on a disc of the same material, and forming part of an electrical circuit, are remarkably sensitive to mechanical shocks, such as the impact of sound waves. The slightest vibration of the apparatus produces marked variations in the resistance of the contact. Sir Oliver Lodge discovered that such a con-

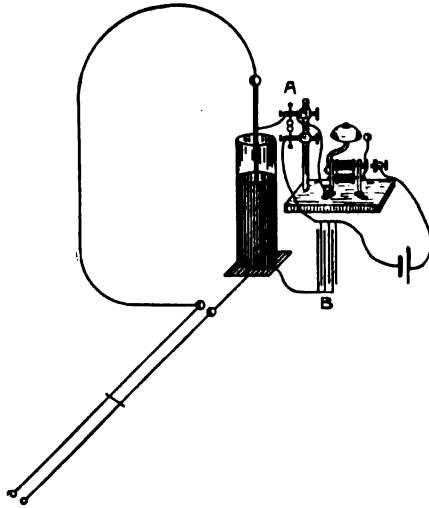

FIG. 94.—Lodge's knob coherer, applied to Syntonie jar experiment (see p. 209). The knobs are shown at A, mounted on the same base as the bell that gives the signal. The vibration of the bell is sufficient to decohere the knobs.

tact was also affected by electric waves, and devised a detector consisting in two knobs of metal, barely in contact (Fig. 94), and forming part of the circuit through a battery and an electric bell.* Whenever this device was ex-

* Lodge, *Jour. Instn. of Elec. Engrs.*, vol. 19, p. 352, 1890. Also *Signalling through Space without Wires*, 3d ed., p. 20.

posed to a sudden electrical impulse, such as that produced by the discharge of a Leyden jar, the contact resistance suddenly decreased, and the bell began to ring.

Lodge considers that the thin film of oxide which separates the surfaces is broken down by the slight difference of potential between them, an infinitesimal spark occurs, and the partially fused surfaces are caused to cohere or weld together. He shows also that the cohesion is aided, if indeed it may not be explained altogether, by the electrostatic attraction between the surfaces: for example, he calculates that the attraction between two surfaces separated by a film of the thickness of 10^{-7} cm., and differing in potential by one volt, would be equal to 4×10^7 dynes per sq. cm., or about one-third of a ton per square inch — a very considerable force, even where the area of the contact surfaces is small.*

This explanation is quite generally accepted as applying, in substance, to the various forms of filings coherers, of which Marconi's coherer, described on p. 131, may be taken as typical. Here there are a large number of imperfect contacts between the individual particles of metal, and so the chance of the apparatus failing to work is greatly reduced, while its sensitiveness is correspondingly increased.

A great drawback to the use of such detectors is the fact that their conductivity continues after the stimulus which caused it is removed, and hence some sort of tapper or mechanical decoherer is required to restore them to their sensitive condition. This is disadvantageous, not only for mechanical reasons, but also because the speed of signaling is limited on account of the time required for the tapper to

* For a fuller exposition of Lodge's ideas, see his *Signalling through Space without Wires*, pp. 86-87.

do its work. A speed of ten to fifteen words per minute is considered quite good for such devices.

To obviate this difficulty, a number of self-restoring "auto-coherers" have been devised, of which the "Italian Navy coherer," invented by Sig. Castelli of the Royal Italian Navy,* and used successfully by the Marconi Com-



FIG. 95.—Italian navy coherer. E, E' are iron or carbon electrodes, and M a globule of mercury.

pany, is a specimen. (Fig. 95.) This consists in a glass tube, similar to that of a filings coherer, plugged with iron or carbon electrodes, between which is a globule of mercury. In a more improved form the electrodes are both of carbon, and embrace two drops of mercury separated by a short iron cylinder. (Fig. 96.)



FIG. 96.—Italian navy coherer—second form. The electrodes, C C', are both of carbon, and I is an iron cylinder separating two globules of mercury.

The action here is entirely automatic. The cohesion between the mercury globules and the electrodes exists only while the stimulus is acting, and the apparatus regains its original sensitiveness as soon as the actuating cause is removed.

* See Angelo Banti, in *Electrician*, Lond., July 11, 1901, p. 477.

This coherer is often used with a telephone in the local battery circuit (Fig. 97), instead of the relay and recorder shown in Fig. 69. When so operated it responds to very rapid impulses, and each spark of the transmitting apparatus produces its individual effect, instead of being merged together with others into continuous dots and dashes, as when a filings coherer is used. The resulting

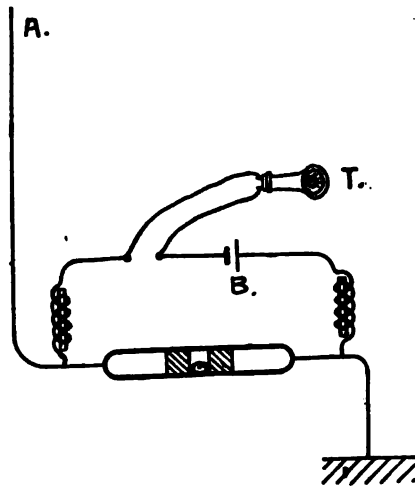

FIG. 97.—Connections of auto-coherer with battery B and telephone T.

buzz which is heard in the telephone is easily read, and the apparatus thus becomes quite effective, especially as the telephone is much more sensitive than any relay and recording device. This arrangement is one of those used by Marconi in his memorable transatlantic experiments.*

* Marconi before Roy. Instn. See *Electrician*, Lond., June 27, 1903, p. 390.

when the first "S" was heard across two thousand miles of ocean.

It has one serious drawback, however; it insists sometimes on cohering permanently, and again, it will cease to act in the middle of a message. Lodge has avoided this irregularity by keeping the contact surfaces in constant motion.* He replaces one of the fixed iron electrodes with a disc of steel, which is revolved continuously by clockwork, in light contact with a drop of mercury covered with a

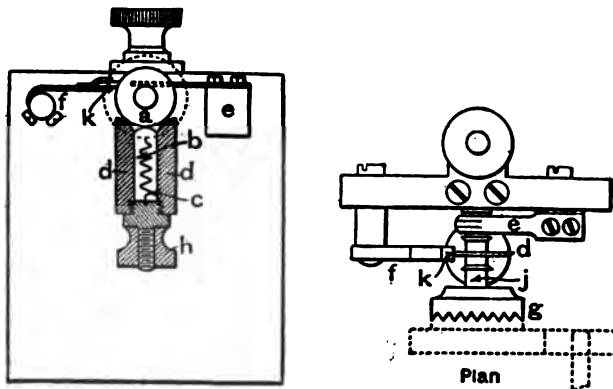

FIG. 98.—Lodge's auto-coherer. A steel disc, a, rotates in light contact with a globule of mercury, b, from which it is normally separated by a thin film of oil.

thin film of oil. (Fig. 98.) The contact surfaces are thus kept clean and fresh, and always in receptive condition.

This device is used directly in connection with a siphon recorder in the Lodge-Muirhead system, which will be discussed later. The recorder, though less sensitive than a telephone, has the advantage of giving a permanent record

* H. C. Marillier on Lodge-Muirhead System, *Electrician*, Lond., March 27, 1903, pp. 930-934.

where the impulses are too feeble to affect positively the ordinary relay and recording apparatus.

Coherers may be made of a great variety of materials. In certain combinations, especially those involving substances that are easily oxidized, the primary phenomenon of coherence, or decrease in resistance, is followed by the opposite effect, and the device regains a condition of high resistance while the impulse is still acting. In an extreme case, as when carbon grains are used in place of metallic filings, the former effect disappears, and we find only an *increase* in resistance whenever the stimulus occurs. Such devices are called *anti-coherers*. The explanation of the phenomenon is somewhat obscure, though it seems probable that the minute sparks which occur between the grains oxidize the surfaces, and so destroy their conductivity.*

3. Mechanical Detectors.— Hertz, in his experiments on the propagation of waves in wires, found that a hoop of

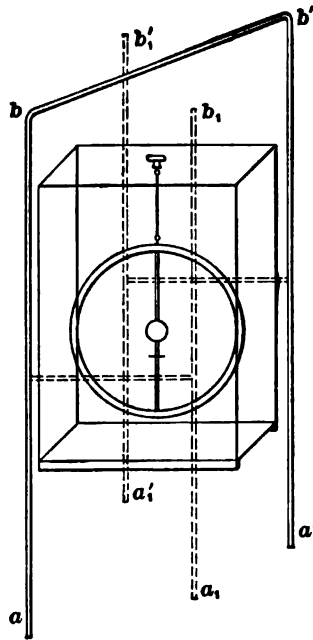

FIG. 99.— Hertz's inductive detector. The hoop of aluminum wire is shown with mirror attached, suspended within the box. The wire *abb'a''* carries the oscillations, which repel the currents that they induce in the hoop.

* For a discussion of this subject, see Hurmuzescu, *Annales Scient. de l'Univ. de Jassy*, Repr. in *L'Écl. Elec.*, June 27, 1903.

wire, suspended by a fibre in the neighborhood of a pair of conductors carrying the oscillations, tended to take up a position perpendicular to the plane of these wires. The rapidly varying currents induced secondary oscillations in the suspended hoop, and the mutual repulsion between these two sets of currents caused the hoop to swing toward the position where the action was a minimum. Hertz's apparatus is illustrated in Fig. 99.*

Similar arrangements have been employed by other workers for the study of the currents set up in an antenna exposed to radiations from a distance. Such devices are useful for quantitative measurements, and give quite accurate results, but they are not applicable to ordinary telegraphic work on account of their sluggish action and the difficulty of making them sensitive.

4. Thermal Detectors.— The thermal detectors referred to on p. 43 are subject to the same objections as the mechanical ones above mentioned: the wire whose heating is measured, however fine it may be drawn by ordinary methods, is still too coarse to be much affected by the feeble currents induced in a receiving antenna; and, even were the heating measurable, the rate of cooling would be too slow to follow the rapid succession of signals required for practical telegraphy.

Recently, however, by an ingenious method, wires have been produced of such excessive fineness as to be free from both these troubles. A rod of silver is cast with a piece of platinum wire as a core, and the whole is drawn down to a diameter of a few thousandths of an inch. In this process the platinum is reduced to a diameter of .0001 inch or less, which is amply fine for all practical purposes.

* See Hertz, *Electric Waves*, Eng. trans., p. 191.

Of such material is the "barretter" of Prof. R. A. Fessenden.* A short loop of the platinum wire is exposed by dissolving the silver casing in nitric acid, and then mounted in a metallic box to protect it from air currents and from stray electrical impulses. Connected in the circuit from the antenna to ground, the oscillations cause it to become heated, the resulting increase in resistance causes a diminution of the current in a local circuit including the loop, and a sound is produced in a telephone.

Such a fine wire loop is sensitive to very feeble currents, and its heat is radiated so quickly that its temperature can follow the most rapid succession of impulses required in practice. Unfortunately, however, a loop that is fine enough to be sensitive is extremely delicate, and is easily burned out by atmospheric disturbances or by stray radiation from the transmitting apparatus.

5. Electrolytic Detectors.—Dr. Lee de Forest and E. H. Smythe have produced a detector which involves an interesting principle.† It depends for its operation on the disruption of the minute metallic bridges or "trees" which form, under suitable conditions, between the electrodes of an electrolytic cell. The apparatus, which they call a "responder," consists in a glass tube similar to that of a coherer, in which are fitted two electrodes, preferably of tin, though other metals will do. The space between the electrodes — about 1/64th inch — is filled with a viscous semi-conducting liquid, such as glycerine with a small admixture of water, together with some peroxide of lead as a depolarizer, to prevent the excessive evolution of gas.

When this cell is connected across a battery of suitable

* See U. S. pat. 706,744, Aug. 12, 1902.

† See U. S. pat. 716,000, Dec. 16, 1902.

voltage, a peculiar phenomenon occurs. The ordinary electrolytic action of dissolving metal from the anode and depositing it on the cathode is accomplished through the agency of ions, of atomic dimensions: here, however, the particles torn from the anode are of ponderable size — indeed, they may easily be seen with the aid of a microscope, as they lie suspended in the liquid. Under the influence (probably) of electrostatic attraction, they arrange themselves in bridges, or “trees,” reaching across from cathode to anode, in much the same way as iron filings distribute themselves between the poles of a magnet. These metallic bridges, in their normal condition, form a path of comparatively low resistance for the current; but when the oscillations from an antenna are allowed to pass through the cell, the bridges are broken down, the conductivity is destroyed, and a sound is produced in a telephone connected in the local battery circuit. The destruction of the bridges is caused by the sudden evolution of gas in the thin film of liquid which separates the individual particles; this gas is promptly absorbed by the depolarizing agent in the solution, and so the particles are allowed to come together and complete the bridges as soon as the oscillations cease. The apparatus is thus self-restoring and constantly receptive, and its action is said to be uniform and reliable.

This automatic responder and telephone, when used in connection with the alternating-current transmitter of high-frequency spark described on p. 151, constitutes a system over which a high speed of signaling is possible.

Another electrolytic detector, embodying quite a different principle, was developed by the writer in the course of a series of attempts to magnify the effect of the heating of Fessenden's “barretter” (see p. 187), by immersing

the wire in a liquid of high temperature coefficient and low specific heat, which was made part of a local circuit. The attempt was unsuccessful, but it led to the discovery that a simple electrolytic cell, when polarized to the proper critical point by the current from a local battery, is remarkably sensitive to oscillatory impulses.* A simple nitric acid solution, for example, with a minute anode of platinum wire .0001 inch in diameter and a larger platinum cathode, gave a clearly readable signal when a coherer was absolutely inoperative.

The effect is quite distinct from that involved in the de Forest responder, for the platinum anode, minute though it is, is not attacked by the electrolyte, and the electrolyte itself is a good conductor. Moreover, the apparent resistance of the cell falls, on the passage of the oscillations, instead of rising.

The phenomenon is a rather complex one which we may not discuss here, except to note that an interesting reversal of the process occurs when the voltage of the local battery is raised to a point where a considerable ebullition occurs at the anode. In this case, the rapid evolution of gas which occurs when the oscillations pass is sufficient to destroy the contact between the liquid and the anode, and interrupt the current. This effect is quite similar to that which occurs in the Wehnelt interrupter, where the sudden evolution of gas from a small platinum anode is caused to break the primary circuit of an induction coil at rapidly re-

* Since the above went into type an announcement has been published of the independent discovery of this principle by Schloemilch, in Germany. The detector that he describes is almost identical with the above. See *Elektrotechnische Zeitschrift*, Nov. 19, 1903.

curring intervals, thus doing away with a mechanical break.

This reverse action, though very strong, is rather irregular and uncertain, so it is neglected in favor of the direct

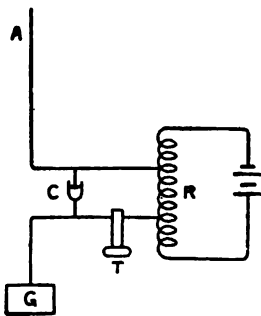

FIG. 100.—Connections of electrolytic detector in an untuned circuit. A is the antenna; C, the detector proper; R, an adjustable inductive resistance, and T, a telephone.

effect, which is perfectly uniform and reliable, and practically instantaneous. The slightest irregularity in the sending spark has its effect in altering the note in the telephone,—indeed, a variation in the temperature or quality of the sending spark is often observed by the receiver when the sending operator himself cannot detect it,—and even when a Wehnelt interrupter is used at the transmitting end, producing sparks at the rate of a thousand or more per second, each impulse is separately detected by the receiver, and the resulting musical note is clear and strong. The speed of signaling is thus limited only by the ability of the operator to handle his transmitting apparatus.

The sensitiveness of this detector is extreme, far surpassing the coherer, and even the delicate magnetic detector of Marconi. It also lends itself readily to tuning.

The arrangement of connections for a simple untuned receiver is shown in Fig. 100, where C is the electrolytic cell, or detector proper, R is an inductive resistance, which serves the double purpose of adjusting the voltage of the local circuit and preventing the escape of the oscillations

The arrangement of connections for a simple untuned receiver is shown in Fig. 100, where C is the electrolytic cell, or detector proper, R is an inductive resistance, which serves the double purpose of adjusting the voltage of the local circuit and preventing the escape of the oscillations

through the battery, and T is a telephone. The telephone may be replaced by a siphon recorder when a permanent record is desired.

6. Magnetic Detectors.—Over half a century ago, Joseph Henry, in the course of his monumental experiments on the relation between electricity and magnetism, tried the effect of discharging a Leyden jar through a coil of wire surrounding a needle. Knowing that a discharge of static electricity is equivalent to an electric current, he naturally expected it to have a similar magnetic effect; but the results were quite the reverse. Not only was the needle

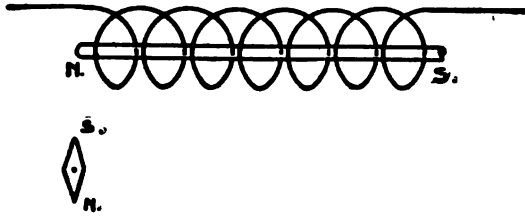

FIG. 101.—Rutherford's magnetic detector. A magnetized steel needle in a coil of wire, with a magnetometer to observe the changes in magnetization.

not uniformly magnetized by the discharge, but after being magnetized in one direction it was often demagnetized or even reversed. With a wonderful insight, he attributed this anomaly to the fact, afterward demonstrated by Feddersen (p. 22), that such a discharge is oscillatory. He says: "The phenomenon requires us to admit the existence of a principal discharge in one direction, and then several reflex actions backward and forward, each more feeble than the preceding, until the equilibrium is obtained."*

* *Scientific Writings of Joseph Henry*, Vol. I, p. 201, 1886.

This principle was applied by Rutherford to a detector of electric waves.* He used steel needles magnetized to saturation and placed in a coil of wire through which the oscillations passed (Fig. 101), and the changes in magnetic state were detected by a magnetometer. Unfortunately, however, with this form of apparatus, a newly magnetized needle is required for each experiment.

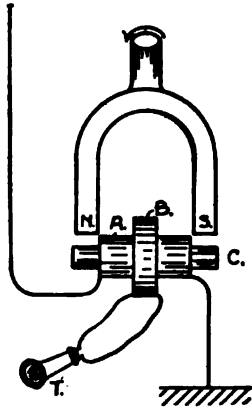

FIG. 102.—Marconi's magnetic detector. A is the antenna coil, B the telephone coil, C the core of iron wires, and N S a permanent magnet rotated by clockwork.

Other workers have improved upon the idea, and Marconi in particular has developed it into a very serviceable detector.† In one form of his apparatus, he uses a bundle of iron or steel wires wound with two coils of copper wire. (Fig. 102.) One of these coils is connected between the antenna and ground, the other, to a telephone receiver. A permanent magnet is rotated by clockwork close to the core, in such a way that its poles, alternately approaching and receding, keep up a continuous variation in the magnetic state of the iron.

Ordinarily, these changes of magnetization are too slow to induce an appreciable electromotive force in the coil, and the telephone is silent; but when oscillations pass through the other winding, the smoothly-varying flux is jarred, as it were, into a sudden

* *Philosophical Transactions*, 1897.

† See paper before Roy. Instn. of Great Britain, June 13, 1903, in *Electrician*. June 27, 1903, p. 388.

change, a momentary current flows, and a sound is heard in the telephone.

The effect may be compared to the well-known fact that a magnetized bar, when struck or jarred, loses part of its magnetism; and it would seem that the rapidly varying impulses caused by the waves have a similar disturbing effect on the molecular state of the iron. It is evidently a hysteresis effect. We know that, when a piece of iron is alternately magnetized and demagnetized, the magnetization

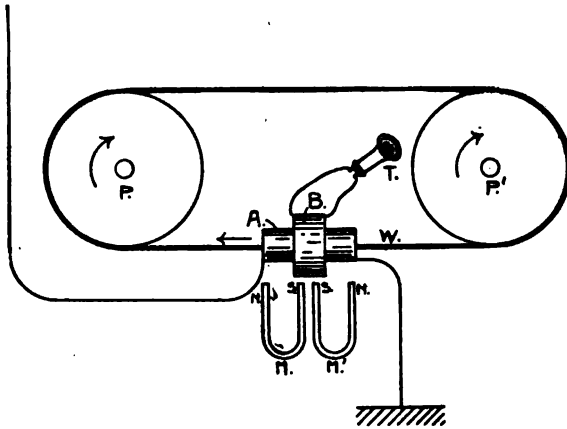

FIG. 103.—Marconi's magnetic detector — improved form. W is a continuous band of iron wires, passing over the pulleys P P', and threading the coils A and B. M and M' are fixed permanent magnets.

always lags behind the magnetizing force, as if the molecules of the metal were restrained by some viscous resistance from arranging themselves in the way the force impels them. With soft iron the hysteresis is not great, but steel, especially when hardened, is very reluctant to change its

magnetic state. Under the influence of the oscillations, however, the hysteresis is diminished, and the molecules, freed from this restraint, jump suddenly into place and a signal is produced.

The sound is loudest when the magnet is approaching the core and less when it is receding, so the sensitiveness of the detector is constantly varying. This is a great disadvantage in practical signaling, and to obviate the difficulty, Mr. Marconi has devised another form of apparatus. (Fig. 103.) Here the magnet is fixed and the core moves — not transversely across the poles of the magnet, but in the direction of its own length. In short, the core is a continuous band of iron wires, passing over two pulleys, and threading a double coil of wire placed between the poles of a magnet. In this way a fresh mass of iron is continuously exposed to the action of the oscillations, and the performance of the apparatus is made uniform and regular.

This apparatus has been so perfected that its sensitiveness is very great, and its action thoroughly reliable.

7. Arrangement of Receiving Apparatus.— Open-circuit detectors of the coherer type are characterized by the fact that a difference of potential between the terminals is necessary to operate them. In its normal sensitive condition no appreciable current flows through the coherer, and it is not until the difference of potential reaches a certain critical point that the insulation breaks down and the particles cohere. It matters little whether this potential be oscillating, slowly alternating, or direct — indeed the voltage of the local battery, if raised above a volt or so, will cause the apparatus to block and become inoperative.

This feature makes the coherer ill adapted to the ordi-

nary connection in series, between the antenna and ground. The base of the antenna is, as we know, a loop of the oscillation, where the current is a maximum, and the variation of potential is normally zero; hence a coherer located at this point works to very poor advantage.

Various arrangements have been devised to avoid the difficulty, for it is obviously impossible to operate the coherer at the nodal point at the top of the wire. One method, due to Prof. Slaby* is shown in

Figs. 104 to 106. If a straight horizontal wire of the

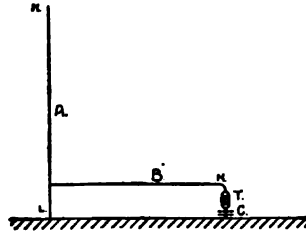

FIG. 104.—Slaby's method of operating a coherer. A horizontal wire B is attached near the base of the antenna A and the coherer T is connected at its outer end. N, N' are nodes of the oscillation, L a loop.

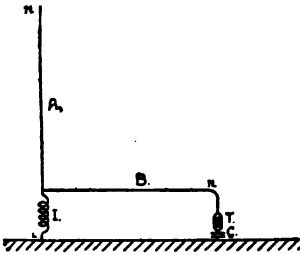

FIG. 105.—Slaby's method (2). An inductance coil I is inserted at the base of the antenna, to stiffen the coupling between the wire B and the antenna.

proper length be attached to the antenna near its foot (Fig. 104), it will vibrate in unison with the latter with a node at its outer end, and a coherer may then be connected between this end and the ground. In order that the horizontal wire may be set in vibration, there must be some variation of potential at its inner end, so it is connected to the antenna at a little dis-

tance above the ground; or, better still, a coil having a small self-induction is inserted in the ground wire. (Fig.

* Slaby, *Die Funkentelegraphie*, p. 110.

105.) In practice, there is no need of stretching the auxiliary wire out straight, for it may as well be wound into a coil of suitable length, as in Fig. 106. In this form the apparatus is called by Slaby a "multiplier," (*Multiplikator*) and we shall consider it further in the next chapter.

Another method of connecting the coherer is through a transformer, or induction coil. (Fig. 107.) This has the advantage, not only of providing an uninterrupted path for the oscillations in the antenna and of establishing a convenient node for the coherer, but, by a suitable arrangement of winding, the voltage may be

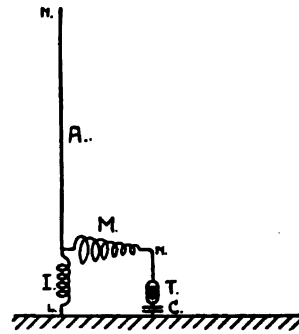

FIG. 106.—If a coil *M* be substituted for the wire *B*, Fig. 105, we have Slaby's "Multiplier."

stepped up so as to increase its effect on the coherer.

It is not sufficient to simply multiply the turns of the secondary winding, as in the case of an ordinary induction coil; for here we are dealing no longer with alternations of such low frequency that the current may be considered the same in all parts of the circuit, but with oscillations of such rapidity that the time required for an impulse to travel from one end of the coil to the other is considerable, compared to the period of the oscillation; and the distributal capacity of the wire itself, acting like a series of condensers strung along the route, stores up energy where it is not wanted, and gives rise to certain peculiar effects. We may compare the induction coil to a pipe line of rigid metal, in which the flow is constant

throughout its length; while the high-frequency coil is like a tube of elastic rubber, which swells and contracts with variations of pressure, and it is even possible to have the water flowing in opposite directions in different parts of the tube at the same time. This property may be turned to useful account, however: for instance, we may so proportion the tube for a given frequency of flow of the water that a considerable velocity may occur at the middle of the tube, while the ends, which are closed, experience only variations of pressure.

This result, for electrical oscillations, has been accomplished by Marconi in his "jigger,"* one form of which is shown in Fig. 108. The primary consists in a single layer of, say 100 turns of insulated copper wire, while the secondary has, say 1,000 turns of finer wire, wound in a peculiar manner. The coil is divided into two equal sections, each of which is wound so as to have a triangular cross-section, the inner layer having the greatest number of turns, and the succeeding layers being tapered off gradually, so that the outer layer has only two or three turns.

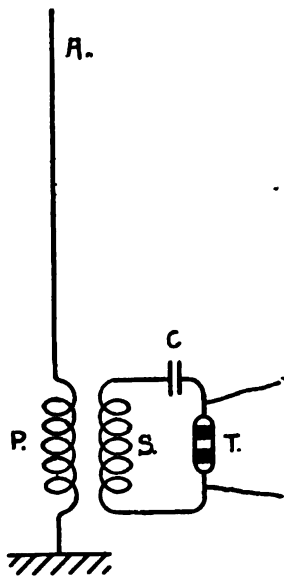

FIG. 107.— A coherer T connected to an antenna A through a transformer, P S. The condenser C prevents short circuiting the battery through the coil.

* See Eng. pat. No. 12,326, June 1, 1898.

The inner ends of the coils are connected together and the outer ends go to the coherer. In the figure, the zigzag lines represent diagrammatically successive layers of the

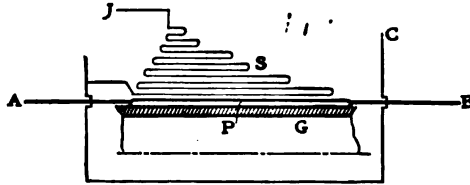

FIG. 108.—Marconi's jigger¹—half section. G is a glass tube on which are wound the primary P and secondary S. Each of the zigzag lines represents a layer of winding. The terminals A E of the primary are connected to the antenna and to earth, and the terminals C J of the secondary go to the coherer and the recording apparatus.

winding, the individual wires being perpendicular to the plane of the paper.

A more improved form of the apparatus* is shown in Fig. 109, and its connections to the coherer and receiving apparatus in Fig. 110. The inner terminals of the second-

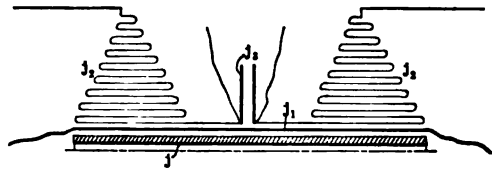

FIG. 109.—Marconi's jigger—improved arrangement. The secondary winding j_2 is divided in the middle and the ends are connected to a condenser, j_1 . For connections, see Fig. 110.

ary winding are connected to a condenser, and thence, through choke coils which confine the oscillations to the jigger circuit, to the relay and local battery.

* Eng. pat. No. 25,186, Dec. 19, 1899.

In this arrangement the coherer is placed at a decided node of the secondary oscillation, whose voltage is much higher than that of the primary. The effectiveness of the device is shown by the fact that it enables signals to be received at ten times the distance that is possible when the coherer is simply inserted in the antenna circuit. Conversely, it makes it possible to use less sensitive coherers, which are much more reliable and easily handled than the very sensitive ones.

The "jigger" is to some extent a syntonic device, as it works best when designed with reference to the height of the antenna and the frequency of the oscillations. It will be considered further in the next chapter, together with a variety of other syntonic receivers.

8. Current Multiplying Devices.— Many detectors differ from the coherer in the fact that their operation does not depend upon the voltage of the oscillation, but on the current. A thermal detector, for instance, is dependent directly upon the heating effect of the current. Such detectors should be placed, not at a node of the oscillation, but at a loop. For this reason they operate effectively when simply connected between the antenna and ground. If it is desired to multiply the effect by a transformer, it should be designed to step-down the voltage and thus increase the current — a process quite the reverse of that which occurs in Marconi's "jigger." To accomplish this successfully, it

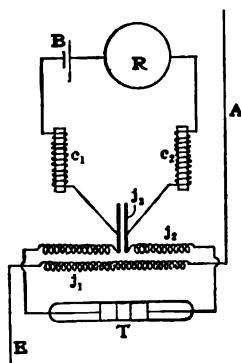

FIG. 110.— Connections of Jigger, FIG. 109. T is the coherer, across the secondary terminals. The battery B and relay R are connected across the condenser j_2 through choke coils C_1, C_2 . The primary j_1 goes to the antenna A and earth E.

is usually necessary to tune the circuits in unison, and we shall consider, in the next chapter, the means by which this may be done.

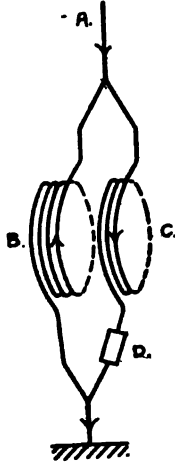

FIG. 111.—A current-multiplying coil for detectors of the closed circuit type. B and C are two coils of unequal numbers of turns, wound in closely inductive relation, A is the antenna terminal, and D the detector. The current in the longer coil B is opposed to that in the antenna, and the current in C is equal to the arithmetical sum of the other two.

Another arrangement, which is not necessarily syntonetic in its action, has been used successfully by the writer. It is based on the principle that rapidly oscillating currents in a system of conductors tend to distribute themselves in such a way as to make the kinetic energy a minimum.* It consists in a simple annular coil, made up of two wires wound side by side, as close together as possible, so that their mutual induction shall be large. The two circuits are similar, except that one has more turns than the other, say in the ratio of three to two, and they are connected in parallel between the antenna and ground. (Fig. 111.)

Now, if the currents in the antenna were continuous or slowly alternating, they would distribute themselves between the two coils according to the resistance; but for rapidly oscillating currents this is not the case. Here the self-induction is the controlling factor. If the currents in the two coils were approximately equal, they would induce a magnetic field of considerable kinetic energy, and the tendency is to reduce this energy to a minimum. This is accomplished when the two currents flow in opposite directions, and are numerically proportional inversely to the

* See J. J. Thomson, *Recent Researches in Elec. and Mag.*, Chap. VI.

number of turns. Their magnetic effects then neutralize each other, and the kinetic energy of the system, as a whole, is a minimum. The current in the antenna, which is equal to the algebraic sum of the currents in the two coils, is thus smaller than either of the latter: for example, in the case cited, if the current in the antenna be unity, the current in coil C will be + 3 units, and that in B will be — 2 units.

Looking at the matter from another point of view, suppose for the moment that the currents in the two coils are in the same direction: the resulting magnetic field will induce an electromotive force in each coil; but the EMF of B will be greater than that of C, and will cause a local current to flow through the two coils in series until its magnetic effect balances that of the main current, and the resulting flux is zero. Unless the difference in the number of turns of the coils is great, the local current will be greater than that in the main circuit, and a detector connected in either branch will experience a correspondingly magnified effect.

It should be remembered, however, that this is not a perpetual-motion machine, and so cannot create energy. Increased current in the detector means an increased expenditure of energy, and this can never be greater than that received by the antenna. Before this limit is reached, the ohmic resistance has its effect, and cuts down the current in the antenna; so that the multiplying effect of the coil goes for naught. It is possible, however, with suitably designed coils, to amplify the signal considerably; thus, with a certain coil having a ratio of turns of 3 : 4, the intensity of the signal was increased nearly fourfold — the full theoretical value.

Usually, a similar result may be accomplished by tuning, and we shall now turn to that phase of the subject.

CHAPTER VI.

SELECTIVE SIGNALING.

1. **The Problem.**— Thus far we have considered mainly two phases of the subject: First, the means of producing powerful vibrations, capable of traveling over long distances; and, second, the construction of a receiving apparatus, sufficiently sensitive to detect these radiations, even when greatly attenuated. Given a powerful transmitter and a sensitive receiver, a new problem presents itself: How can we control and direct these radiations so that they shall reach the receiver for which they are intended, and not make havoc with all others within their sphere of influence? The radiations from an antenna spread out uniformly in all directions, like light from a beacon, and the receivers which we have been considering, like so many human eyes, respond almost equally well to the signals from all transmitters within their range. For use on shipboard, and between ships and shore, this is a distinct advantage; for it is important that a ship be able to communicate with any other ship, and that all vessels may connect with the shore stations. Besides, where vessels are scattered over the high seas, the chances of interference are small, and even where two or three ships are "talking" at once, it is not difficult to distinguish between them. Especially where telephonic receivers are used, the different qualities of sound due to the peculiarities of different transmitters make it quite easy to hear and read any one of several messages coming at the same time, just as several conversations may be

carried on in the same room without interference; but when the requirements of commercial work multiply stations and magnify their power, we shall have a veritable stock exchange, in which selective signaling will be indispensable. The demand is not so much for secrecy, for this may always be secured by means of codes. There is not the least difficulty in tapping a land telegraph line, and eavesdropping over the telephone is easier still,—yet the telegraph and telephone are among our most valuable instruments of commerce. The main requirement is to communicate at will with any one of several stations, without interfering with messages passing between other stations at the same time.

Three methods have been proposed for accomplishing this:

First. To direct the radiation of the transmitter, like the beam of a searchlight, so that it shall go only where it is wanted.

Second. To tune the oscillations of transmitter and receiver so that only those stations which have the same frequency or “tune” can communicate: this is equivalent to providing lighthouses with lights of different colors, and causing the observer to look through colored spectacles which cut off all light but that for which he is looking.

Third. To give the radiations a distinctive character, aside from their wave-frequency, *e. g.*, by varying the frequency of interruption of the spark: thus, lighthouses which are otherwise alike are caused to emit flashes at stated intervals, by which they may be distinguished.

All three of these methods have been used, and each has its peculiar advantages.

2. Directed Signals.—The first and most obvious method is to send the signals only in the direction where they

are needed. Marconi, in some of his earliest experiments, used this method, following the lead of Hertz in concentrating the radiations into a bundle of parallel rays, by means of a parabolic reflector (see p. 132). This arrangement is entirely feasible and quite successful where small oscillators are used; but the mirrors, in order to be effective, must be at least comparable in dimensions to the wave-length of the oscillator, and, for the best results, they should be much larger. When long antennæ are used, emitting radiations with a wave-length of a thousand feet or so, reflectors are quite out of the question.

It is unfortunate that some such device as this has not been made practicable, for it would not only result in a great saving of energy, due to its concentration in the one direction where it can be made useful, but the range of signaling would be greatly extended, on account of the diminished attenuation of the waves,—just as the beam of a searchlight is more efficient and more penetrating than the light of an ordinary beacon. Lacking this, we must have recourse to one or other of the methods of tuning.

3. Syntonic Signaling.—The second method is that of electrical resonance, or syntony. We have learned a good deal about this in Part One, and now we need only review the principles involved, and see how they may be applied in practice.

We have seen that, in order to have strong resonance between two circuits, both must be persistent vibrators. If the oscillator sends out waves whose amplitude decays rapidly, the resonator, whose vibration is built up as the summation of all the impulses received, will not be fairly started before the impulses die out. On the other hand, if the oscillation of the resonator is strongly damped

a point is soon reached where the energy is dissipated as fast as it is received, and no amount of persistence on the part of incoming waves will increase the amplitude of its vibration.

The phenomenon of multiple resonance shows that the strongly damped vibrations of a Hertzian oscillator may excite oscillations in resonators of widely differing periods, just as a beam of white light appears red when viewed through a red glass, and green when viewed through a green glass, whereas a beam of pure color should be visible only through a glass of the proper tint.

So with strongly damped oscillations, strong resonance and sharp tuning are both impossible, and we miss the two great advantages of a good syntonie system: strong response to a feeble signal, and the ability to distinguish one set of signals from another.

Now, a grounded antenna is simply half of a Hertzian oscillator, on a large scale; and we know that the latter is a very poor vibrator — its oscillations decay to one-tenth of their initial amplitude in about nine vibrations. (See p. 67.) Increasing the size of an oscillator does not affect its damping, if the proportions be kept the same — a large oscillator radiates more energy than a small one, but it also contains more, and the *proportion* of the total energy sent off during each oscillation is the same, whatever the size of the oscillator.* So we would naturally expect the oscillation of a simple antenna to have a high rate of decay, and this is indeed the case. The reason for this will be apparent, if we refer again to the diagrams, Figs. 89–92. It is readily seen that the fraction of the total energy sent off in the detached wave during each oscillation depends upon the number of Fara-

* See Macdonald. *Electric Waves*, p. 77.

day tubes which go to make up the wave, and on the relative energies of the detached part of a tube and of the part that goes back to the oscillator. The process of separating off the waves is very much like the boyish game of "snap-the-whip," where each boy represents a tube. The chances of a certain boy being snapped off the line depend upon his distance from the end of the line; and the number of boys snapped off, and the violence with which they go, depend upon the suddenness of the snap.

So with our oscillator. The chances of a tube being snapped off depend upon the wideness of the circuit that it makes; the tubes that stretch nearly straight from pole to pole of the oscillator, or from the antenna to ground, simply shrink back into the conductor; while those that make a wide circuit into space are snapped off. Again, the number of tubes snapped off and their relative energy depend upon the suddenness of the snap; *i. e.*, the frequency of the oscillations. If the oscillator be allowed to discharge slowly through a high resistance, all the tubes will have time to shrink back and be absorbed, and there will be no radiation; but if the discharge be sudden and rapid, many of the tubes will be snapped off, and the number and relative size of the detached loops will depend upon the suddenness of the snap.

This suggests one method of prolonging the oscillations. If we can diminish the frequency of the oscillation without altering the electrostatic field about the antenna, the rate of decay will be decreased. This may be accomplished by inserting a self-induction coil between the antenna and the ground, thereby increasing the "inertia" of the circuit and slowing down the oscillations. It is

analogous to hanging a weight at the middle of a vibrating string.

The curve, Fig. 112, shows the result of such an experiment made by the writer. The transmitter was a plain multiple-wired antenna, in series with which was a coil of twenty turns of coarse wire having an inductance of

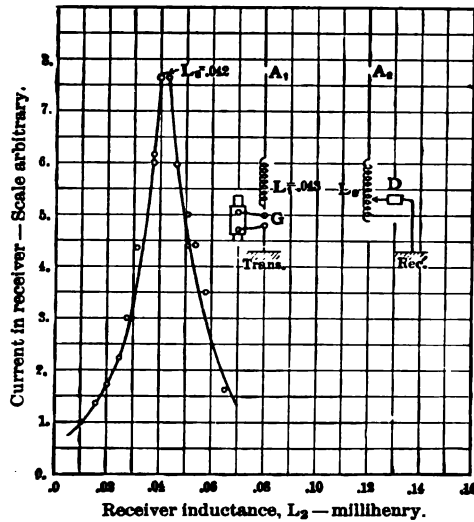

FIG. 112.—Curve of resonance between two distant antennæ with inductance in series. L_1 is the constant inductance of transmitter, L_2 the variable inductance of receiver, D the detector and measuring apparatus.

.043 millihenry — or about three times that of the antenna itself. The receiver was a similar antenna with an inductance that could be varied. The abscissas of the curve represent the values of this inductance, and the ordinates, the corresponding intensities of the current in the receiver. By this means a fairly sharp resonance point is found, whereas the same antennæ, without

the extra inductance, are so nearly dead-beat that resonance between them is difficult to detect at all, and the receiver responds almost equally well to oscillations of widely varying frequencies.

It should be noted, however, that this method of prolonging the oscillations does so at the expense of intensity of the signals. The total energy of the oscillation is the same, whether the inductance be used or not; but in the latter case the energy is radiated with a sudden rush, making a strong evanescent wave like the sound of a drum, while in the former the same energy is distributed over a longer interval, as when a bell is struck, and the amplitude of the wave is correspondingly reduced. This method is thus of limited utility, unless means be employed for increasing the initial energy of the oscillation.

Another method of prolonging the oscillations, which possesses certain advantages, is by increasing the capacity, as Marconi did with his early antennæ by attaching a plate at the top. (See p. 141.) This increases the total energy of the wave-train, and at the same time prolongs the oscillations by reducing the frequency. Looking at it from the Faraday tube point of view, the total number of tubes proceeding from the antenna is increased, owing to the increased charge, but as the frequency is diminished, a relatively smaller number of tubes are "snapped off" at each oscillation. The oscillations are thus prolonged without a corresponding decrease of intensity.

4. Lodge's Syntonic Cones and Leyden Jars.— Sir Oliver Lodge and Dr. Alex. Muirhead devised a system of syntonic signaling, combining both these principles.* The transmitting apparatus is the ungrounded oscillator re-

* See English pat. No. 18,644, July 16, 1898.

ferred to on p. 136, with an inductance coil inserted between the two large capacity-cones. (Fig. 113.) The receiving apparatus is similar, with a coherer substituted for the spark gap — or rather connected in shunt across the inductance, thereby getting the full difference of potential in the coil without interfering with the oscillations.

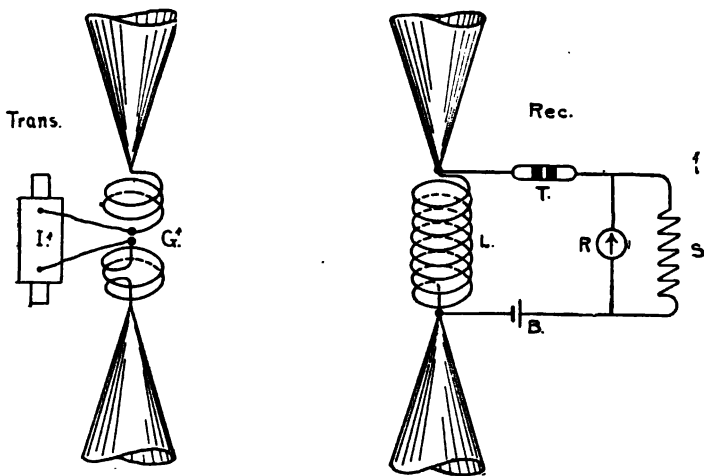

FIG. 113.—Lodge's syntonized cones with inductance coils (cf. FIG. 71, p. 136); Trans. is the transmitter. Rec. the receiver, with coherer T, battery B and relay R. S is a non-inductive shunt to eliminate the choking effect of the highly inductive receiving apparatus R.

Even this combination method, though it is operative within certain limitations, falls short of what is required in a practicable working system.

Lodge also devised an experiment which illustrates beautifully the principle of resonance.* A pair of Leyden jars whose opposite coatings are connected, each pair

* Lodge, *Signalling through Space without Wires*, 3d ed., p. 6.

by a loop of wire, are placed a short distance apart, as shown in Fig. 114. The circuit of one of the jars is interrupted by a spark gap, so that oscillations may be set up when the jar is charged by means of an electrical machine, and the other is provided with a slider, by which the length of the circuit may be varied until its period is the same as that of the oscillator. When this is done,

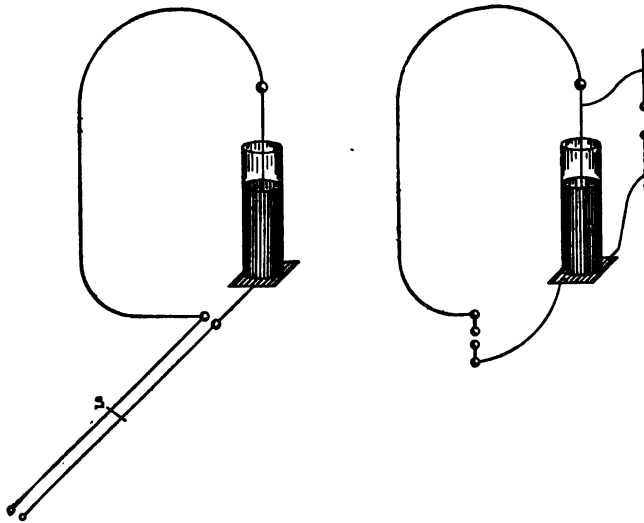

FIG. 114.—Lodge's syntonized Leyden jars. The two circuits are tuned to resonance by moving the slider *S* until sparks appear in the "overflow" air-gap.

resonance occurs and sparks may be drawn from the second jar.

In this case, nearly all the Faraday tubes run straight across, through the glass, from coating to coating of the jars — very few of them reach out into space — conse-

quently the oscillations are very much prolonged and extremely sharp resonance is possible. Only a small movement of the slider is required to throw the jars out of tune. Unfortunately, however, such a system is a very poor radiator, and the effect can be observed only at a short distance — indeed the properties of good radiation and persistent oscillation are directly opposed to each other, and the conditions which improve the one impair the other. Some sort of a compromise must be effected.

5. Marconi's Concentric Cylinders.—Marconi devised a system embodying the principle of the syntonic jars, but he made the "jars" very long and narrow, so that they would have a considerable radiating surface. In other words, he used two vertical concentric cylinders of zinc, separated by an air space, which formed a condenser of considerable capacity and at the same time played the

part of an antenna.* The cylinders at the sending station were connected together through an inductance and a spark gap, and the inner cylinder was grounded. (Fig.

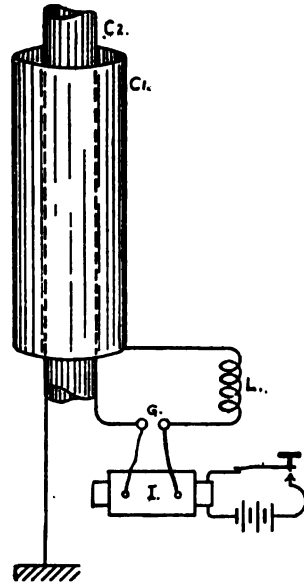

FIG. 115.—Marconi's cylinder transmitter. The concentric cylinders, C_1 , C_2 , combine the functions of condenser and antenna, and the frequency may be adjusted by varying the inductance L .

* See Eng. pat. No. 5,387, March 21, 1900.

115.) At the receiving station the arrangement was similar, but without the spark gap and with a coherer and recording apparatus connected across the inductance.

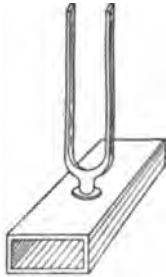

FIG. 116.—
Acoustic analogue of the antenna with closed oscillating circuit. The resonating box takes energy from the tuning fork and radiates it as sound.

This system was used with considerable success for a time, and was found capable of working over a distance of thirty miles, with cylinders seven meters high and 1.5 meters in diameter, but it was finally supplanted by a better arrangement.

6. The Closed Oscillating Circuit.—The great desideratum is a transmitter whose oscillations are prolonged as much as possible, and yet whose radiation is not correspondingly diminished in intensity; in other words, one which is capable of giving off energy at a good rate for a considerable time. This means that the initial supply of energy must be large.

The closed oscillating circuit of Lodge's syntonic jars possesses two of these qualities; its oscillations are prolonged, and the supply of energy is limited only by the capacity of the jars and the voltage to which they are charged. But this arrangement is a poor radiator. Is it not possible to combine such an oscillating system of high power with a good radiator in such a way that its energy may be made available for signaling? This is what is done by the physicist when it is desired to increase the sound of a tuning fork: the fork itself is a persistent vibrator but a poor radiator, so it is mounted on a resonating box, tuned to the same pitch as the fork, and thus the energy of the fork is made available as sound. (Fig. 116.)

The same thing may be done with electrical oscillators, by coupling a closed oscillating circuit (a persistent vibrator) to an ordinary antenna (a good radiator). The coupling may be accomplished in a number of ways, all of which are modifications or combinations of the three methods illustrated in Figs. 117 to 119: the first conductive, the second electrostatic, the third inductive.

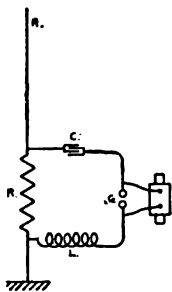

FIG. 117.

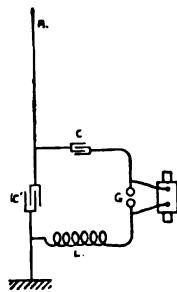

FIG. 118.

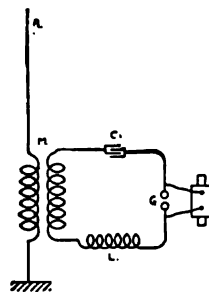

FIG. 119.

FIGS. 117, 118, 119.—Three methods of coupling a closed oscillating circuit, CGL , to an antenna A ; the first, a rigid electrical connection across a resistance R (FIG. 117); the second, an elastic connection across a condenser C' (FIG. 118); the third, an inductive coupling through a transformer, M (FIG. 119).

These three methods may be illustrated by their mechanical analogues, Figs. 120 to 122, which show three methods of communicating the vibrations of a tuning fork to a stretched string. The first is a rigid mechanical connection between the fork and the string; the second is an elastic connection, through a spring; the third is through a transversely vibrating rod or lever carrying at its center of vibration a mass, whose inertia serves the purpose of a fulcrum.

So, in coupling the oscillating circuit to the antenna, we may have a rigid electrical connection across a dead resistance (FIG. 117); an elastic connection across a con-

denser (Fig. 118);* or an inductive coupling through a transformer (Fig. 119). In all these cases the essential element is the creation of a variation of potential at the base of the antenna, as in the mechanical analogues we must have a variation of pressure on the string, if it is to be set in vibration. In the first case, this is accomplished by the ohmic drop in the dead resistance; in the second, by the elastic reaction of the dielectric in the condenser; in the third, by the inertia reaction of the



FIG. 120.

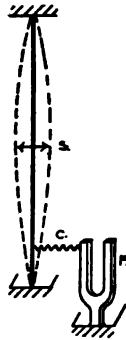

FIG. 121.

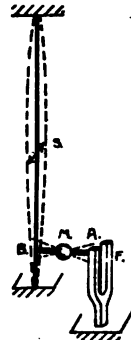

FIG. 122.

FIGS. 120, 121, 122.— Three methods of coupling a tuning fork F to a vibrating string S, tuned in unison with it; the first, a rigid mechanical connection through the reciprocating rod R (FIG. 120); the second, an elastic connection through a spring C (FIG. 121); the third, an inertia coupling through the mass M (FIG. 122), which acts as a fulcrum to the vibrating rod A B.

other surrounding the coil. The first is obviously a wasteful method (at least in its simple form), as the ohmic drop is accomplished at the expense of energy converted into heat, with a consequent damping of the os-

* A more strictly analogous case is that of Lecher and of Hertz, Fig. 34.

cillations. The second is more efficient, and has been advocated by some workers. The third is the method which, with its modifications, is almost universally used, and we shall now consider it more carefully.

7. Inductively Interlinked Circuits.—Where we are dealing with very rapid oscillations, the inductive effects of the currents are so powerful that no special apparatus is required to produce them—two wires lying side by side affect each other strongly, and even a stovepipe erected near an antenna may be the source of disagreeable shocks. In the case of Lodge's syntonic jars, the effect is one of almost pure induction—there is no true radiation worth mentioning. So, to connect the closed oscillating circuit to the antenna, a transformer of very few turns is sufficient. It is usually a coil of stout wire or cable inclosing a similar secondary coil, without iron, and the whole immersed in a vessel of oil. (cf. Fig. 77, p. 147.)

Now let us see what occurs when such a system is put in operation. To get a clear idea of the phenomena we should put aside all preconceived ideas as to the operation of a transformer, and look at the matter afresh from Maxwell's point of view. We shall thus be in a position to see some notable apparent exceptions to the theory as it is usually applied to ordinary alternating circuits.

The oscillating currents in the closed primary circuit create a variable magnetic field in the space inclosed by the coil. The "inertia" of this field constitutes the self-induction of the primary, and there must be an electromotive force across the terminals of the coil to overcome this inertia. But this field does not affect the primary alone; at least part of it is embraced by the secondary

also, and a similar electromotive force is induced across the secondary terminals. In like manner (referring to Fig. 122) the vibrating tuning fork tends to set in motion the mass M, attached to the rod AB which connects it with the string. If the end B, of this rod, be held immovable, the mass will vibrate with the fork, requiring a force to keep it in motion, and so retarding the vibration of the fork as if it were attached to the prong. But, at the same time, the inertia reacts at the fixed end, B, of the lever, and so a force is exerted which tends to set this end in motion. This force will impose forced vibrations on the string, whatever the period of the fork may be, and the intensity of the force depends upon the lengths of the lever arms, AM and BM. So our transformer will impose forced oscillations on the antenna, whatever the period of the primary circuit, and the electromotive force which produces these oscillations is approximately proportional to the ratio of turns. Thus far no exceptions.

Now let the frequency of the primary circuit be changed, by altering either the capacity, C, or the inductance, L.* As the frequency of the oscillation approaches the natural frequency of the antenna there is a marked increase in the amplitude of the secondary oscillation, until the point is reached where the two circuits are "in tune," and the amplitude of the oscillation reaches a maximum. When this occurs, the current in the secondary of the transformer is too great to be

* Remembering that the frequency is $N = \frac{1}{2\pi \sqrt{LC}}$. L and C being

both expressed in the same system of units, and N being in cycles per second.

neglected, and being in opposition to the primary current, it tends to neutralize the effect of the latter in producing a magnetic field. In the ideal case (never attainable in practice) where both circuits are perfectly free oscillators exactly in tune, and where the two coils of the transformer are perfectly interlinked, without magnetic leakage, we should have no flux whatever in the transformer, no EMF. across either primary or secondary, and the ratio of primary to secondary *currents* would be equal to the inverse ratio of turns.

This is analogous to the case where the tuning fork and its string are exactly in tune, and the amplitudes of their respective vibrations are proportional to the lever arms, AM and BM. The mass, M, will then be motionless, and there will be no force acting on either the string or the fork. Any change in the amplitude of either vibration will set the mass M in motion, and the inertia reactions which result will tend to retard one vibration and augment the other, until the stable condition is again attained.

This leads to the conclusion that the amount of stepping-up of the voltage from the primary condenser to the antenna is not directly proportional to the ratio of turns of the transformer—indeed, in our ideal case, the reverse is true; *i. e.*, the greater the ratio of secondary to primary turns, the less the secondary current, and consequently the potential to which the antenna is charged. With a simple 1 : 1 transformer the two currents are equal and the potential depends simply upon the ratio of the capacities of primary and antenna. We may thus step up the voltage to any desired extent (within limits), by increasing the capacity and decreasing the inductance of the primary circuit.

In actual practice these principles are modified to some extent by the fact that the antenna is a good radiator, and so there must be a transfer of energy to it from

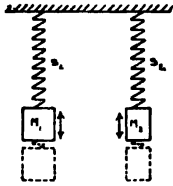

FIG. 123.—Two masses M_1 , M_2 , supported by springs S_1 , S_2 , and adjusted to vibrate up and down in synchronism.

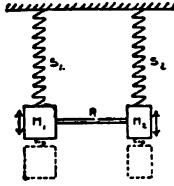

FIG. 124.—The same masses connected by a light rod R . The vibration remains unchanged.

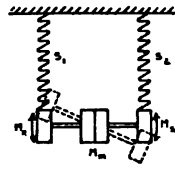

FIG. 125.—The masses M_1 and M_2 of FIGS. 123 and 124 divided, and part of each moved to the middle of the rod. If the ratio $M_1 : M_2$ is equal to $M_1 : M_2$, the system vibrates about M_m as a fulcrum with an increased frequency.

the primary. Hence, to use the mechanical figure, the mass M is never really motionless; and there must always be a flux in the transformer and a corresponding departure from the ideal conditions.

Another corollary is that two circuits which are turned separately to the same period will not necessarily be in tune when brought into inductive relation; or, if they are in tune, their frequency will generally be altered.

This may be illustrated by another mechanical model. Suppose two masses, M_1 and M_2 , (Fig. 123) to be supported, each by a spring, S_1 and S_2 , in such a manner they may vibrate freely up and down with a frequency depending upon the mass and on the elasticity of the spring. Suppose further that each mass is so proportioned to the elasticity of its spring that their periods of vibration are the same.

Now let the masses be connected by a rod of negligible mass (Fig. 124). They will vibrate in unison, as before, with the frequency unchanged.



FIG. 126.— Two closed oscillating circuits with their capacities C_1 , C_2 , and inductances L_1 , L_2 , so adjusted that the product $L_1C_1 = L_2C_2$. The two circuits are then in tune.

Suppose now that the masses be divided, and a portion of each moved out to the center of the rod (Fig. 125). The masses will no longer vibrate together, moving up and down in unison, for this is an unstable condition; but each will tend to vibrate with a new frequency of its own depending upon its mass, but restrained by the rod. If the masses M_p and M_s be properly selected with reference to their springs these frequencies may be made the same, and the masses will then vibrate in unison, *but not in phase*: M_p will move up when M_s its moving down, in saw-saw fashion, while M_m remains motionless. The frequency of the system will be higher than the original frequency, according to the proportion of the individual masses made inactive by moving them to the middle.

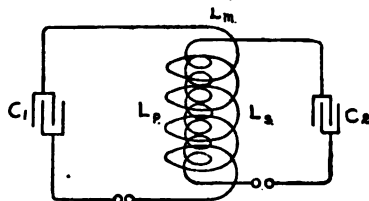

FIG. 127.— The same two circuits brought into inductive relation. The mutual induction, L_m , partly neutralizes the self-inductions L_1 and L_2 , leaving L_p and L_s to control the frequency.

Thus we may have two electrical oscillating circuits (Fig. 126), each with its inductance, L , and capacity, C , corresponding to the mass and elasticity of the mechanical vibrators, and tuned to oscillate in unison. When these circuits are brought into inductive relation, however, the conditions are changed (Fig. 127). The magnetic fields of the two inductance coils now overlap, and may be separated into three parts: First, the part whose flux is interlinked with the primary coil only, and constitutes the effective primary self-induction, L_p ; second, the part whose flux is interlinked with the secondary alone, and constitutes the effective secondary self-induction, L_s ; and, third, the part whose flux is interlinked with both, and constitutes the mutual induction, L_m . This mutual flux tends to become zero,* and so reduce the kinetic energy of the field to a minimum, leaving the fluxes of L_p and L_s alone to control the frequency of the oscillation; just as the mass M_m tends to remain motionless, and let M_p and M_s control the vibration.

In practice, however, this state of affairs is only approximated, as the mutual flux is necessary to transfer energy from the primary to the secondary. This may be illustrated in the mechanical model by supposing the mass M_s to be retarded by a friction, which dissipates energy in heat as the antenna does in radiation. The mass M_m will then not remain motionless, but will vibrate sufficiently to transfer energy from M_p to supply that lost by M_s .

The departure from the ideal conditions is usually not very great. For example, Fig. 128 shows a resonance curve

* It affects the two oscillations in opposite senses, augmenting the one and opposing the other, while it, in turn, owes its existence to a difference between the opposing magnetic effects of the currents. It thus tends to its own destruction.

between the two antennæ referred to on p. 207, taken under the same conditions, except that the sending antenna was coupled inductively to a closed oscillating circuit. The same coil L_1 was connected in series with the sending antenna, but in the one case (Fig. 112) this coil was used as a simple self-induction, while in the other (Fig. 128)

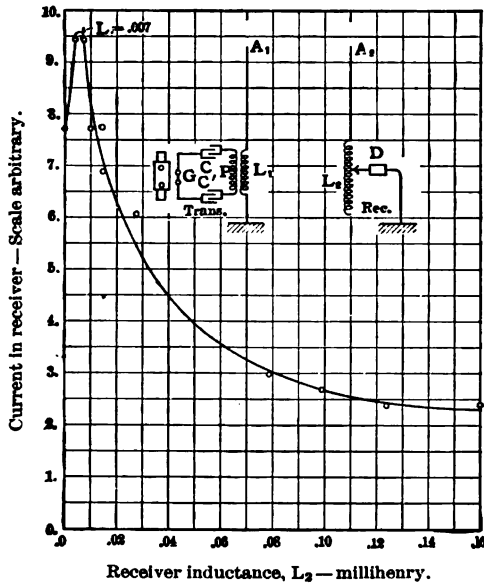

FIG. 128.—Curve of resonance between a transmitting antenna A_1L_1 , with closed oscillating circuit CPCG, and a receiving antenna A_2 , with variable inductance L_2 and detector D. The secondary coil L_1 is the same as L_1 in FIG. 112.

it was placed within a second coil, which constituted the primary of a transformer of which the antenna coil was the secondary. These two circuits were tuned to resonance by adjusting the primary capacity. At the receiving end the same variable inductance was used in the simple an-

tenna circuit, and the curve is plotted on the same scale, with values of this inductance as abscissas and intensities of signals as ordinates. The spark length was decreased for the compound oscillator, so that the maxima have approximately the same value, and the curves may thus be compared directly.

The difference is striking. In the curve, Fig. 112, the inductance at the resonance point is .042 millihenry — almost exactly the same as that in the sending circuit. In Fig. 128, the inductance is reduced to .007 millihenry, or one-sixth of this value. In other words, five-sixths, or 83%, of the self-induction L_1 is neutralized by the mutual induction, and the frequency is thus brought so near to the natural frequency of the antenna that the maximum occurs almost on the axis. And this with a transformer that was very loosely wound, so that there was a large amount of leakage. With closely interlinked coils the approximation to the ideal conditions may become very close.

The resonance curves are not sharp, owing to the use of the simple antenna circuit for receiving—a poor resonator.

To recapitulate, we find that the use of a closed oscillating circuit, with a condenser of large capacity compared to that of the antenna, not only prolongs the oscillations, by virtue of its property of storing energy, but it may also increase the intensity of the radiation by increasing the potential to which the antenna is charged; and that the intensity of the radiation, as well as the rate of decay, may be varied within wide limits by changing the windings of the transformer and the amount of additional self-induction in the primary or secondary circuits. Thus the apparatus may be adapted at will to use with tuned receivers, or with the simple “responsive” or untuned receivers previously described. The frequency also may be

varied within wide limits, without changing the proportions of the antenna — an important feature where several stations must intercommunicate at will. In such cases, each station may have several sets of apparatus, each tuned to a different frequency, which may be connected to the antenna as needed. Indeed it is possible to work two or more transmitters at once from the same antenna, each sending signals in its own tune, just as the belly of a violin — an aperiodic radiator — may resound to the notes of two or more strings at once.

8. Tuned Receiving Apparatus.— Given a transmitter capable of emitting radiations with a small rate of decay, the next requisite of a syntonic system is a strongly-resonant receiver.

Many of the factors which go to make a good transmitter apply equally well to the receiver. A good radiator is, in general, a good absorber; so an antenna which works well at the sending end may be used with good results for receiving. So also, a persistent oscillator usually makes a good resonator, and a correspondingly poor absorber. Hence we must resort to the same kind of compromise at the receiving end as was necessary in the transmitter, coupling the antenna to some sort of resonant circuit, in which the detector is placed. This resonant circuit may be similar to the closed oscillating circuit of the transmitter, though very much reduced in size, as the currents which it is called upon to carry are extremely feeble and the correspondingly low voltages require no special care in insulating. The specific arrangement, however, depends upon the form of detector to be used, and its ohmic resistance. In this respect there is the greatest variety, with the coherer, which is normally open-circuited, at one end of the scale, and the low-resistance thermal and magnetic detectors at

the other; and each requires a different mode of treatment to obtain the best results.

Putting aside the coherers for the moment, let us consider the closed-circuit detectors. These may be connected simply in series, in the resonant circuit, as indicated diagrammatically in Fig. 129.

Now the damping of such a circuit is governed, not by radiation, but by the dissipation of its energy in ohmic

and other losses; hence it would seem at first glance that the lower the resistance of the detector the better. But this is not necessarily the case. In the first place, low resistance usually involves lack of sensitiveness, as when a magnetic detector is wound with few turns of coarse wire; and, in the second place, it is not the absolute value of the resistance, but the ratio of resistance to inductance,

$\frac{R}{L}$, that determines the damping factor, or "logarithmic decrement." Hence, it is usually desirable to design the resonant circuit with a large inductance, and the proportionately

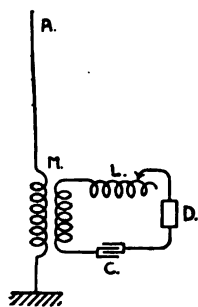

FIG. 129.—Receiver with closed circuit detector *D* in a local resonant circuit. D.C.M.L. The inductance *L* is made variable for the purpose of tuning.

small capacity necessary to give the proper frequency. Here, however, enters the objection that small capacity means small current, and we encounter the dilemma of damped oscillations on the one hand and weak impulses on the other, just as we found in considering the transmitter that prolonged oscillations are opposed to good radiation. Fortunately, the solutions in the two cases are similar. Most detectors of the type which we are now

considering are cumulative in their action, and the intensity of the signal depends upon the total energy received from the wave-train—not on its intensity. As in the transmitter we strive to increase the energy of the wave-train, even at the expense of intensity, so in the receiver our aim must be to apply the energy to the detector in the most efficient manner, sacrificing the intensity of the current, if need be, in the interest of resonance. In the one case this resulted in large capacity and small inductance, while in the other the tendency is to small capacity and large inductance.

As an extreme case, we see the “jigger” of Marconi (p. 197), where the coil is long and fine and the capacity is reduced to that of the wire itself and the coherer connected to its terminals. In this case, the small capacity involves high voltage, which is just what is wanted to operate the coherer to best advantage. The capacity of a coherer is a rather uncertain quantity; hence, to obtain sharp and definite tuning, it is often desirable to connect a condenser of larger capacity (C' , Fig. 131), as a shunt across the coherer terminals, thus making its variations negligible. Unfortunately, however, this has the effect of reducing the potential, and so diminishing the sensitiveness.

Having considered some of the general principles which govern the operation of syntonic systems, let us now look at a few specific forms of apparatus, and see how the principles have been applied.

9. Marconi Coherer System.*—A system which is used very successfully by the Marconi company is illustrated in

* Marconi, before Roy. Instn. Great Britain, June 13, 1903.

Figs. 130 and 131, the former showing the transmitting apparatus and the latter the receiver. Both embody the closed oscillating circuit which we have been considering, coupled to the antenna through a transformer.

At the sending end of the line is a condenser, C, consisting in a battery of Leyden Jars, charged by an induction coil, I, operated by a telegraph key in series with the automatic break. This condenser discharges through the

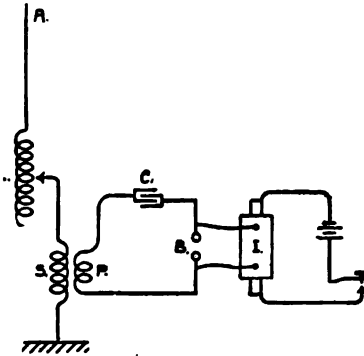

FIG. 130.—Marconi coherer system—transmitter. I is the induction coil, with battery and key, B the spark-gap. C an adjustable condenser, P, S the oscillation transformer, and L a variable inductance in series with the antenna A.

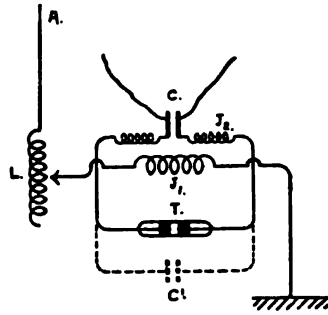

FIG. 131.—Marconi coherer system—receiver. A is the antenna, with variable inductance L, J, J, the jigger, T the coherer and C a condenser, to which the relay and recording apparatus are connected. C' is an additional condenser sometimes used to improve the resonance.

primary, P, of a transformer, which is made up of a few turns of stout stranded cable immersed in oil. The condenser C, primary coil P, and spark gap B, make up the closed oscillating circuit, which has no separate inductance coil—the self-inductance of the primary, whose loosely wound turns permit a good deal of magnetic leakage, being sufficient. The secondary is connected to the antenna through a coil whose inductance may be varied at will, to

facilitate tuning. The frequency of the primary circuit may also be varied by changing the capacity of the condenser, so that the two circuits may be adjusted, not only to resonate with each other and thus secure the most efficient radiation, but also to vibrate in unison with the receiving apparatus.

The receiver (Fig. 131) is similar in principle to the transmitter, though very different in construction. The antenna is connected through a variable inductance, L , to the transformer, J , which, in this case, is the peculiarly-wound "jigger" described on page 197. The coherer is connected to the outer terminals of the secondary, while

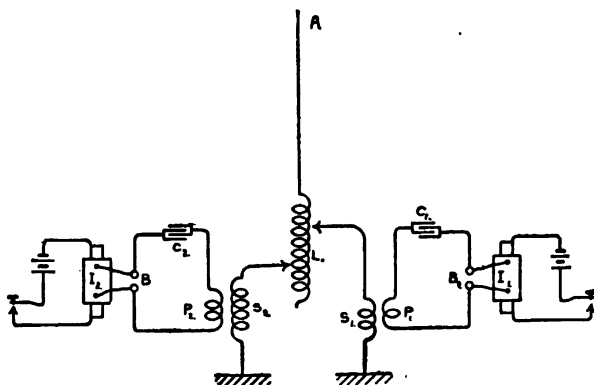

FIG. 132.— Marconi transmitters arranged for multiplex working on a single antenna.

the inner terminals go to a condenser, C , across which is connected the local battery and the sensitive relay which operates the recorder. The "jigger" itself, as we have already seen, is to a considerable degree syntonous in its action, but where sharper tuning is desired a condenser, C' , is sometimes connected in shunt across the coherer. This,

by virtue of its larger capacity, buries any irregularities in the capacity of the coherer, and makes the apparatus more perfectly selective, though less sensitive.

Figs. 132 and 133 show this apparatus arranged for multiplex working, with two transmitters at one station and two receivers at the other, both sets connected to the same pair of antennæ, though tuned to different frequencies.

The coherer at best lends itself reluctantly to tuning; hence, where the most perfect selectivity is desired, Mar-

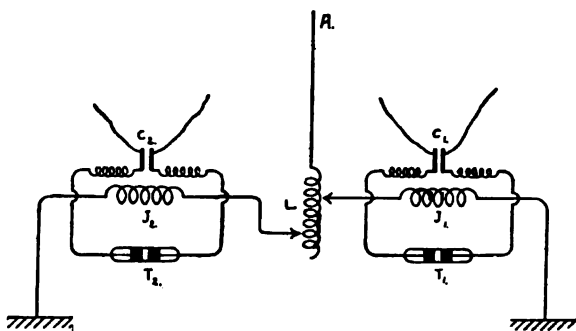

FIG. 133.— Marconi receivers arranged for multiplex working.

coni often uses the magnetic detector, with a specially constructed jigger designed to place the detector at a loop of the oscillation, where the current is a maximum and the voltage small—just the reverse of that used with the coherer.

10. Slaby-Arco System.*—In this system the coupling between the closed oscillating circuit and the antenna is

* See Slaby, *Die Funkentelegraphie*, pp. 114, 115; also C. Ardt, *Die Funkentelegraphie*, Leipzig, 1903, p. 39.

partly inductive and partly by direct metallic connection. Instead of a transformer with separate windings, there is a single coil of wire which plays the part of both primary and secondary, on the principle of the "auto-transformer"

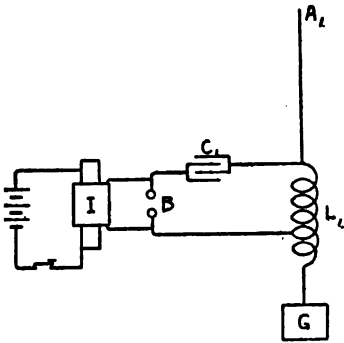

FIG. 134.—Slaby-Arco system — transmitter. B, the spark-gap; C_1 , a Leyden jar condenser; L_1 , the coupling coil.

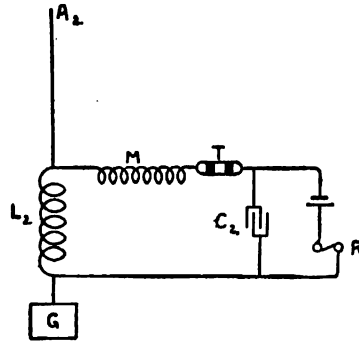

FIG. 135.—Slaby-Arco system — receiver. L_2 , the coupling coil; M, the multiplier; T, the coherer; C_2 , a condenser, and R, the relay.

of ordinary alternating-current practice. The condenser circuit is connected across a portion of the coil, and the antenna circuit across another portion (see Fig. 134), and the ratio of turns of these portions is made variable, to facilitate tuning. The capacity of the condenser, C_1 , may also be varied, so that the condenser circuit may be made to oscillate in resonance with the antenna circuit, and both be tuned to the frequency of the receiver.

The receiver is similar in principle, but modified in form. The coil, L_2 (Fig. 135), is retained in the antenna circuit, to determine its frequency and to act as an auto-transformer in coupling the two circuits together, but there is an additional coil, M, in the receiver circuit, whose func-

tion is that of the "multiplier," described on page 196. It is wound with fine wire of such a length that its own period of oscillation is the same as that of the antenna, and a node is produced at its outer end, where the coherer is connected, similar to that which occurs at the top of the antenna.

We should keep clearly before us the essential difference between the oscillating circuits of transmitter and receiver, as it applies to this and to most other coherer systems. In the case of the transmitter, the inductance is usually small, and the total length of the circuit is small compared to the wave-length. It is thus sufficient to assume that the current is the same in all portions of the circuit, and the frequency is determined by the simple formula

$$N = \frac{1}{2\pi\sqrt{LC}}.$$
* In the case of the receiver, however, the coil is so long that an appreciable time is required for an impulse to travel from one end to the other, and, in the special case where this time is equal to a quarter period, a stationary wave will be produced with a node at the outer end and a loop at the inner end. The current flows in and out at the latter, while only variations of potential occur at the former. It is the potential at the node that is utilized to operate the coherer.

The case of the transmitter may be illustrated by a cord of small mass stretched by springs and carrying a weight in the middle. (Fig. 136.) The system vibrates as a whole

* Remembering that L , in this case, is the *effective* value of the self-induction, after deducting from the true self-induction the effect of the mutual induction in the transformer or auto-transformer. See p. 219. The effect of resistance is usually small, and is here neglected.

with a frequency depending simply on the ratio $\sqrt{\frac{\text{elasticity}^*}{\text{mass}}}$. We need not consider the form of the weight nor the location of the springs. But if the mass and elasticity be dis-

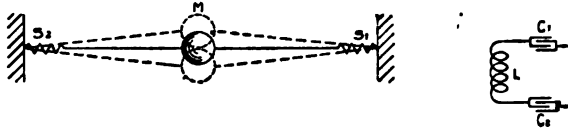

FIG. 136.— Model illustrating the action of an oscillating circuit with concentrated inductance L and capacity C_1, C_2 , which are analogous to the mass M , and the elasticity concentrated in the springs S_1, S_2 .

tributed uniformly along the cord (Fig. 137), an impulse applied at the middle takes an appreciable time to travel to

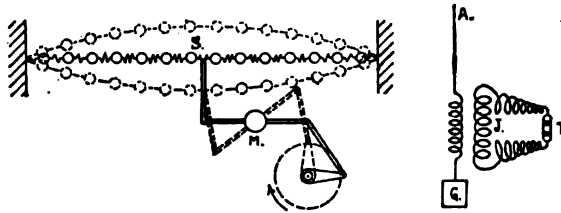

FIG. 137.— Model illustrating the operation of Marconi's "jigger," whose distributed capacity and inductance (elasticity and mass) are so proportioned to the frequency that the current (velocity) imparted through the mutual induction (mass M) to the secondary (weighted spring) is transformed into potential (tension) at the free terminals of the coil (ends of spring).

the end. In the special case where this time is equal to a quarter period of the impressed impulses, the string will

* Where the "elasticity," or ratio of force to displacement, is equal to $4 \times \text{tension} \div \text{length of cord}$. To complete the analogy, note that the capacity of a condenser, or ratio of its charge to potential, is analogous to the reciprocal of an elasticity.

vibrate with a loop where the force is applied and a node at each end. Moreover, if the damping of the system be small, the forces occurring at the node may be much greater than the impressed force, and the system will act

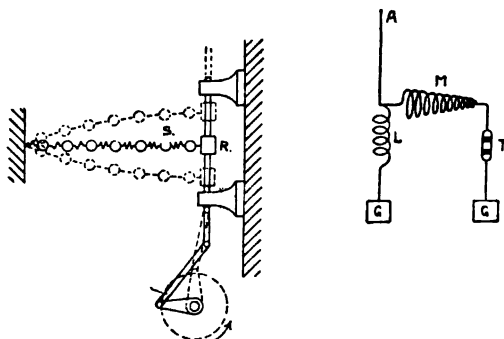

FIG. 138.—Model illustrating the operation of Slaby's "Multiplier." The current (velocity) imparted directly to the multiplying coil M (weighted spring) by the antenna (reciprocating rod R) is converted into potential (tension) at the outer end of the coil (spring). The potential at this point may be much greater than that applied at the other end of the coil.

as a "multiplier," as in the case of Slaby's coil, M (Fig. 138), or Marconi's jigger, J (Fig. 137). Indeed, in many respects the multiplier is the equivalent of half of the jigger, though in the one case the oscillation is impressed on the coil by induction from a primary, and in the other the current is fed directly into one end of the coil from the antenna.

This similarity may be illustrated by comparing the models, Figs. 137 and 138. In the former, the oscillation is impressed on the weighted spring at its middle point, through the freely-suspended mass M (cf. page 214), and the spring vibrates like a piano cord with a loop in the

middle and a node at each end. In the latter, the motion is forcibly applied, directly at one end of the weighted spring, which vibrates with a loop at this end and a node at the other.

The increase in voltage at the outer end of the coil is analogous to the well-known "Ferranti" effect (so-called), which is observed when one end of a two-conductor cable of suitable proportions is connected to the terminals of an alternator. When the length of the cable bears the proper relation to its distributed capacity and inductance and to the frequency of the alternator, electrical resonance occurs, and the voltage at the free end of the cable may become much greater than that of the generator. The energy which leaves the generator as a current flowing into the cable is transformed into potential energy, stored in the cable as a condenser, and measured by the increased potential at the distant end.

11. Braun's System.*— Prof. Ferdinand Braun has produced a system whose distinctive feature is the absence of a ground connection. The sending apparatus (Fig. 139) comprises a closed oscillating circuit coupled to the antenna circuit through a transformer, P, S. The antenna, A, is connected to one terminal of the secondary, and the other terminal, instead of being grounded, is attached to a capacity area in the form of a cylinder of metal, made in two parts which telescope one over the other so that the area of the surface may be varied to facilitate tuning. The antenna circuit thus approximates a Hertzian oscillator in which one conductor is greatly attenuated and the

* F. Braun, *Über drahtlose Telegraphie*, *Physikalische Zeitschrift*, 1902, p. 143. Also A. Voller, *Elektrische Wellentelegraphie*, Hamburg, 1903.

other shortened and expanded, though it is doubtless true that the capacity area, acting as one coating of a condenser of which the earth is the other coating, performs to some extent the function of a ground connection, thus extending the range of the apparatus beyond the limits of free Hertzian radiation.

The condenser, $C_1 C_2$, consists in a number of small tubular Leyden jars, and the transformer comprises a primary winding of a few turns of heavy copper cable or tube, with a secondary winding with a larger number of turns of smaller conductor. Tuning is accomplished by

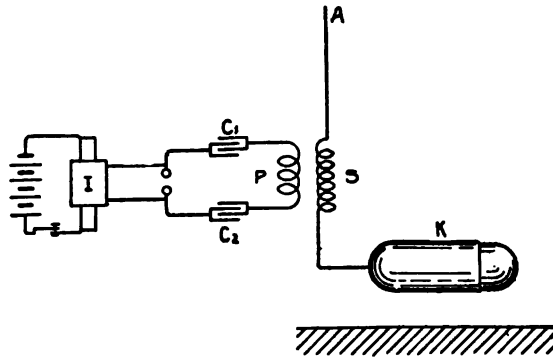

FIG. 139.— Braun system — transmitter. The antenna, instead of being grounded, is connected through the secondary S of a transformer to an adjustable capacity area K .

changing the number of tubes in the primary condenser and by adjusting the telescopic capacity.

The receiver, Fig. 140, combines the elastic and inductive methods of coupling. The antenna circuit, with its adjustable capacity area, contains a condenser, $C_1 C_2$, across whose terminals is shunted the primary, P , of a trans-

former, which, with the condenser, constitutes the primary resonant circuit. The coherer, T, is placed in a secondary circuit, inductively coupled with the first, and thus a considerable irregularity in the capacity of the coherer may occur without destroying the resonance of the primary circuit.

The coherer itself is somewhat different from those previously described. It consists in a hard rubber tube with

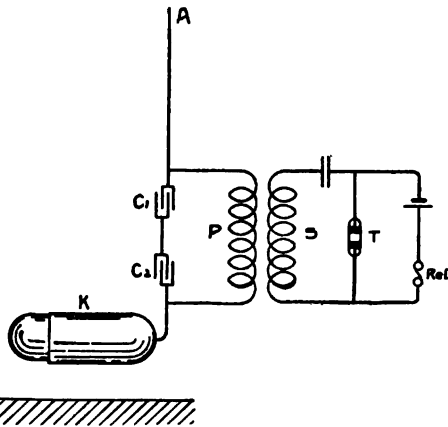

FIG. 140.—Braun system—receiver. The primary resonant circuit C_1C_2P is coupled "elastically" to the antenna through the agency of the condensers C_1 , C_2 , and inductively to the coherer circuit through the transformer P, S.

electrodes of steel, between which is a quantity of hardened steel filings. One of the electrodes is provided with an adjusting screw, whereby the distance between the electrodes, and hence the sensitiveness, may be regulated.

12. Lodge-Muirhead System.*—Lodge has described a number of forms of syntonie apparatus—commencing

* See *Electrician*, Lond., March 27, 1903, pp. 930-934.

with his syntonic Leyden jars, then the syntonic cones connected by an inductance (p. 208), then this inductance was made the primary (or secondary) of a transformer, the other winding of which was connected to the coherer (or

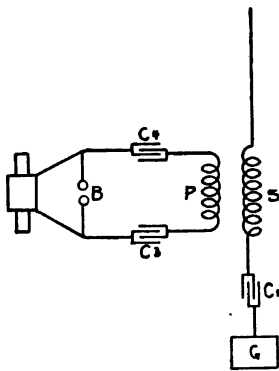

FIG. 141.—Lodge-Muirhead system—transmitter. A closed oscillating circuit, C_2BC_3P , coupled to the antenna through a transformer PS. An adjustable condenser C_1 in series in the antenna circuit.

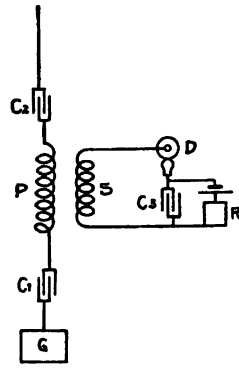

FIG. 142.—Lodge-Muirhead system—receiver. Condensers C_1 and C_2 in series with the antenna and primary P of transformer. Mercury-steel coherer D, in secondary circuit, operating syphon recorder R.

to the condenser and spark-gap). With the advent of the grounded antenna, this arrangement evolved itself into that shown in Figs. 141 and 142, the former representing the transmitting and the latter the receiving apparatus. The connections are so similar to others that we have considered that we need not discuss them in detail, except to note that a condenser, C_1 , and sometimes also another, C_2 , is connected in series in the antenna circuit. It is convenient to make these condensers adjustable, to allow of tuning the antenna circuit without changing the inductance. The antenna circuit is connected with the oscillat-

ing circuit of the transmitter or with the resonant circuit of the receiver through a transformer, and each of these circuits has its own condenser, arranged in much the same way as in other systems that we have considered.

Another arrangement of receiving apparatus is shown in Fig. 143. Here the transformer is dispensed with, and the coherer circuit is connected in shunt across the resonant circuit, which has a direct electrical connection with the antenna.

The detector used with this system is the mercury-steel coherer, having a steel disc rotating continuously in light contact with a globule of mercury (see page 184), and operating a siphon recorder.

13. Limitations of Syntonic Signaling.—The systems above described are all designed to use detectors of the coherer type, whose characteristic is a normally open circuit which becomes closed under the influence of the oscillations. Its action is a sort of trigger effect: the oscillation in the resonant circuit increases in amplitude until it is able to break down the insulation of the coherer, and the signal is received. While the resonant rise of the oscillation is going on, the coherer is, in effect, a condenser of small capacity, and must be so considered in calculating the period of the resonant circuit. This capacity is not a definite quantity, but is constantly varying as the blows of the tapper change the arrangement of the filings in the tube; hence the problem of tuning is a difficult one, and

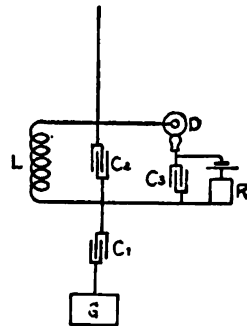

FIG. 143.—Another form of Lodge-Multhead receiver. Inductance L , capacity C_2 , and coherer circuit C_3D , all in multiple.

leads to the adoption of the various expedients which we have considered, for making the coherer capacity a matter of minor importance not vitally affecting the resonance of the apparatus.

With detectors of the closed-circuit type the problem is simpler. Here the oscillatory currents pass freely through the detector, which usually has little effect on the period of the circuit. Hence the design of the receiver is governed by the simpler principles which apply to the case of the transmitter, and the main concern is to so proportion the resonating circuit that the current shall have the maximum effect on the detector compatible with the conditions of good resonance. The principles involved have been considered already, and we need not go farther into details which interest only the specialist.

We should note, however, one fundamental fact. Any detector is primarily a device for translating energy.* It receives the energy of rapidly oscillating currents and transforms it into some form — mechanical, thermal, chemical, or otherwise — in which it can be utilized. Now the criterion of a good resonator is that its damping — which is only another way of saying its rate of dissipation of energy — be small. The very fact of a receiver being operative involves an expenditure of energy and so imposes a limit on the resonance of the circuit.

*The coherer is an apparent exception, as it seems to act more as a relay than as an energy-transformer; but recent experiments show that the degree of coherence, and hence the intensity of the signal, depends not only upon the intensity of the impulse, but also on its duration. There is thus an important sense in which even the coherer may be accepted as conforming to the general rule.

See Hurmuzescu in *Annales Scientifiques de L'Université de Jassy*, reprinted in *L'Éclairage Électrique*, June 27, 1903.

At first glance it would seem as if a strongly resonant receiver must necessarily be an insensitive one, but fortunately this is not the case. Most detectors of the closed-circuit type are cumulative in their action: it is not only the strength of current flowing through the detector that determines the intensity of the signal, but the duration of the current must be considered as well. A resonator which performs a hundred oscillations and gives up (on an average) a hundredth part of its energy at each swing may give as strong a signal as one which affects the detector at ten times that rate, but only performs ten vibrations. The important thing is to see that the energy is utilized in the detector and not wasted in ohmic resistance of the conductors and dielectric losses in the condenser. This is simply a question of careful design of the apparatus, which has been solved successfully by a number of workers. The result is a receiving apparatus whose damping is small enough to make it a good resonator, yet a fair proportion of the energy received from the ether is made effective in producing a signal. Its characteristics approach, to a fair degree of approximation, those of a piano string — a vibrator which, growing out of the crude, tinkling harpsichord, has been so perfected that its note is quite persistent, considering that it is set in vibration by a single blow.

And this brings us to the next point: we know that a strongly resonant receiver alone does not make a good syntonic system, but we must look at the limitations imposed by the transmitter. The vibration of the receiver depends upon the energy which it absorbs, whether this be given by a sudden impulse or distributed over a longer period. If we depress the loud pedal of a piano, so as to lift all the dampers from the strings, and then beat a

drum in the room, all the strings will respond — feebly, it is true, but all equally well. So the strongly-damped radiations of a simple antenna will, if they have sufficient energy, affect even a good tuned receiver to some extent, though ordinarily the effect is trifling. If necessary, as in the case of a malicious attempt to block a receiver, the interference may be cut out by making the inductive coupling between antenna and resonant circuit very loose — thus, if our piano cord be protected by a felt pad, it may receive quite a hard blow without being set in vibration, yet it will respond to a prolonged, though feeble, synchronous vibration.

Such precautions are usually unnecessary, and it is better to avoid interference by using only properly constructed transmitters. If a person may be restrained from disturbing the peace by making unnecessary noises in the street, why should not the same principle apply to etheric disturbances?

However this may be, prolonged oscillations have other advantages than those which concern the question of selectivity. Returning again to the piano, with the loud pedal depressed, suppose a note to be sung into the instrument. The string tuned to this note will respond loudly, even though the note sung be quite feeble. If the same note be struck on another piano, the same response will occur, though less loudly. If the note be struck repeatedly, the response will be louder. Now, the damping of even a good tuned transmitter may be considerably greater than that of a piano string, hence the energy represented by its radiations is small, considering their intensity. Suppose, for example, a transmitter makes 100 oscillations before their amplitude is greatly reduced. If

the wave frequency be 1,000,000 per second — corresponding to a wave-length of about 1,000 feet — the oscillation persists for $\frac{1}{10,000}$ second. If now the spark- or group-frequency be 100 per second — a rather large figure for mechanical interrupters — the oscillation endures for only one hundredth of the interval between sparks, and for 99% of the time the transmitter is absolutely inactive. No resonator is persistent enough to bridge over this interval, so repetitions of the impulse, as when the same note was struck repeatedly on the piano, are useless for increasing the intensity of the signal. It is possible that a compound oscillating system, like that of Prof. Fleming (p. 153), may be so designed as to charge the small secondary condenser several times for each charge of the primary, and thus bring the wave-trains close enough together to have a cumulative effect on the receiver, though to what extent this may be done has not been made public by the inventor.

If it were possible to generate an absolutely undamped radiation, analogous to the sound of the voice in our piano experiment, the intensity of the signal would be greatly increased, even though the amplitude of the waves were very small. Under such circumstances, a simple Hertzian oscillator would radiate energy at the rate of over twenty horse-power.*

Such a generator has never yet been made practicable. Mechanical generators will not do, on account of their low frequency. To feed energy into an electrical oscillator at each reversal, to replace that lost by radiation, seems possible from a theoretical point of view, and there is experimental ground for encouragement in this

*See Hertz, *Electric Waves*, Eng. trans., p. 150.

direction; but as we are dealing with facts, not possibilities, we must pass that by until such an apparatus is put in operation.

However perfect the resonance between transmitter and receiver may be made, there will always be a practical limit to the number of stations that may be tuned to selectivity, as there is a limit to the number of strings in a piano. To escape this restriction we may have recourse to the third and last method of securing selectivity.

14. Other Means of Securing Selectivity.—Where the number of stations within the sphere of each other's influence is so great that it is impracticable to differentiate them by their wave-frequencies, some other characteristics must be added to their radiations, by which they may be distinguished. There are several ways of doing this.

Mr. Tesla has proposed the plan of having each station emit two wave-trains of different frequencies, either simultaneously or in succession, and providing the receiver with two separate tuned circuits, so arranged that resonance in either alone will not give a signal, but both must respond together.* The number of combinations is thus increased, after the fashion of a combination lock, as the square of the number of individual frequencies.

Another method is to give to each station a definite rate of recurrence of the sparks, or group-frequency, and to tune some part of the receiving apparatus to respond to this frequency. For example, if the signals are received on a telephone, the ordinary diaphragm may be replaced by a weighted tongue, which vibrates at a defi-

* Tesla, U. S. pats. Nos. 723,188, March 17, 1903, and 725,605, April 14, 1903. Application filed July 16, 1900.

nite frequency. The telephone will then respond only to signals whose group-frequencies correspond to the natural period of the tongue, even though the detector may be in active operation.

This method was proposed by Professor Rathenau, of Berlin,* for use in connection with a conductive system of wireless telegraphy (see p. 112, footnote).

M. Blondel applied the same principle to Hertz-wave telegraphy,† and proposed several methods—mechani-

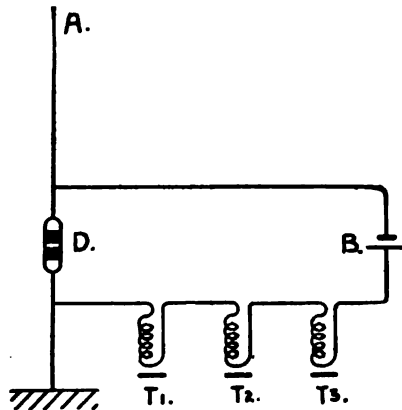

FIG. 144.—Blondel's mechanical method of tuning to group frequencies. T_1 , T_2 , T_3 are mono-telephones, each tuned to respond to a different spark-frequency, D is an auto-coherer or other self-restoring detector, A the antenna, and B a battery.

cal and electrical—for tuning the receiver to the comparatively low frequencies involved. He prefers to use

* Professor Rathenau, *Elektrotechnische Zeitschrift*, v. 15, p. 616, 1894.

† See note addressed to the French Academy in 1898, *Sur la Syntonie dans la Télégraphie sans fil*, Comptes Rendus. 21 Mai, 1900, p. 1383; also Eng. pat. No. 21,909, May 3, 1900. Accepted Nov. 9, 1901.

Mercadier's "mono-telephones,"* which were designed by their inventor for use in multiplex wire-telegraphy and are so constructed as to have a very definite period of vibration. A number of these telephones, each tuned to a different note, may be connected in the local receiver circuit (Fig. 144), and several messages may thus be received at the same time. It is, of course, necessary to use a self-restoring detector.

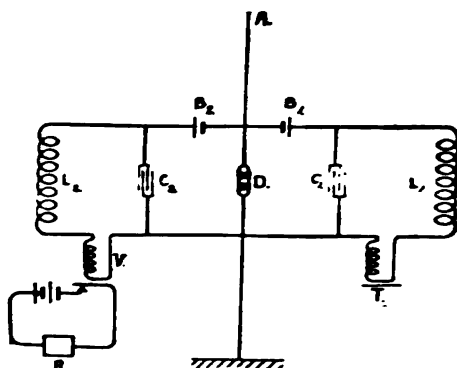

FIG. 145 — Blondel's method of electrical tuning to group frequencies, showing two receivers. The local circuits $C_1L_1T_1$ and $C_2L_2V_2$, with capacities C_1 , C_2 and inductances L_1 , L_2 , are tuned to their respective spark frequencies. On the right is shown a mono-telephone T_1 , for receiving by ear, and on the left a vibrating relay V , with recording apparatus R .

M. Blondel also applies the principle of electrical resonance, as in Fig. 145, which shows two receivers connected to the same antenna. Each receiver circuit, including battery and telephone (or relay), has its capacity and inductance so adjusted that its natural period is the

* See *Elektrotech. Zeitschr.*, April 27, 1899, p. 305; also *Annales Télégraphiques*, 1898, p. 287.

same as that of the interrupter at the sending station to which it is to respond.

By these means the selectivity of the system is made independent of the wave-frequency of the signals, and even a strongly damped radiation is incapable of affecting a receiver which is not tuned to receive it.

15. Conclusion.— We have traced briefly the development of the art of wireless telegraphy from its germ in Maxwell's epoch-making conceptions regarding the electromagnetic field to its fruition in a practical working system, containing all the essential elements of a successful enterprise. Let us now glance at the subject from a commercial point of view, and see what has been practically accomplished, and what are the prospects of future progress.

To say that all the problems have been solved, and that the system now stands complete, would be idle prattle; but much has been done. The problem has passed through the hands of the prophet, the mathematician, the physicist, and the practical experimenter; it is now in the hands of the engineer and financier, to perfect and correlate the achievements of all these workers, and fuse them into the complex organism which a commercial enterprise of this kind must eventually become. From the vision of Maxwell the seer to the fulfilment of Hertz was twenty years; from Hertz's discovery to Marconi's first demonstration in England was nine years,* from this exhibition of a working, though crude, Hertz-wave telegraph to the present day is little more than seven years — yet what progress has been made!

* Marconi applied for his first English patent, No. 12,039, June 2, 1896, and the demonstration referred to took place shortly after.

To-day, commercial wireless telegraphy is an established fact. The traveler on an ocean liner can communicate at will with his friends on shore, and in some cases can read a morning paper from the steamer's press, containing the latest shore news. The navies of most of the great nations have equipped, or are equipping, their fighting ships with what they consider an indispensable instrument of modern warfare. Snow-bound Alaska and remote islands of the sea are put into communication with the outer world. Land stations have been set up and operated, paralleling wire lines. Transatlantic wireless telegraphy has been demonstrated by the actual transmission of messages between England and America, while smaller stations have carried on their business without interference from the powerful "thunder houses" nearby. It is needless to multiply instances showing what has been actually done: enough has been said to show that wireless telegraphy is no longer a laboratory experiment, but an accomplished fact, and several companies are now carrying on business for all those who care to employ their services.

To make predictions as to the future is not the purpose of this paragraph. Rather let the reader look for himself at what has already been achieved, and draw his own conclusions. The writer is not one of those enthusiasts who believe that wireless telegraphy is destined to turn the cable into a rusting relic of the past and to relegate the wire lines to the scrap heap. The telephone did not supplant the telegraph, nor did the trolley-car make the steam railroad obsolete; but each has found its own sphere of usefulness, and the established systems, far from suffering from the innovations, have gone on increasing their traffic. Is it not

reasonable to think that our twentieth-century commerce will supply enough business to occupy all the systems that may be put in the field? The future of wireless telegraphy is now in the hands of the practical man, and it remains for him to show how he will occupy the territory thrown open by the pioneers who have preceded him. Many of the world's best thinkers and workers have prepared the way — let him now go in and possess the land.

