

MACHINERY'S REFERENCE SERIES

EACH PAMPHLET IS ONE UNIT IN A COMPLETE
LIBRARY OF MACHINE DESIGN AND SHOP
PRACTICE REVISED AND REPUB-
LISHED FROM MACHINERY

No. 9—DESIGNING AND CUTTING CAMS

CONTENTS

The Drafting of Cams, by LOUIS ROUILLION - - -	3
Cam Curves, by ARTHUR B. BABBITT and F. H. SIBLEY	16
Notes on Cam Design and Cam Cutting, by JAMES L. DINNANY - - - - -	28
Suggestions in Cam Making - - - - -	34

621.835
D46

CHAPTER I.

THE DRAFTING OF CAMS.

A cam is a device for converting circular into reciprocating motion. It generally consists of a disk having an irregular face that acts as driver of a follower in contact with it, or else of a groove cut in a flat or curved surface. Cams are very useful adjuncts to many forms of machines, as by their aid various complex and complicated movements may be obtained that were otherwise impossible. Their use is, however, attended with some objections of a character serious enough to warrant the substitution of some other method of arriving at a desired result when such other method is available. Among these objections may be mentioned the considerable amount of friction, producing wear, and the noisy action of cam movements. Despite these objections, cams have a wide use and are employed in many familiar machines.

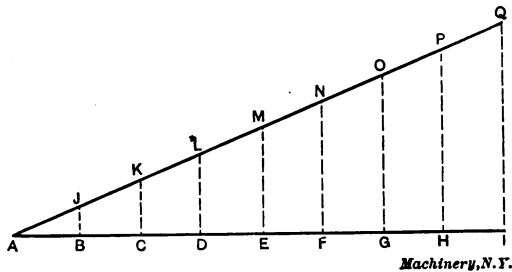

Fig. 1. Diagram, graphically showing Motion imparted to Follower by Cams in Figs. 2 and 3.

Harvesters, printing presses, sewing machines, looms, and steam-valve mechanisms are a few of such machines to which cams contribute part of the action. The more complicated forms of automatic machinery, automatic screw machines, for instance, depend largely upon the aid of cams. The various machines used in the manufacture of shoes are also good examples of this class.

Laying Out a Cam for Uniform Reciprocating Motion.

The process of laying out cams is simple and easily acquired. The laying-out of a heart-shaped cam will serve as an illustration of the general method. This cam is used to convert circular motion into uniform reciprocating motion. Let it be required to lay out a cam that will move a follower with uniform velocity through a throw of $1\frac{1}{2}$ inch. This action may be graphically shown by the aid of a diagram, Fig. 1. The action of but one-half the complete movement need be considered, as the return of the follower is along a curve similar to that occasioning the rise. Therefore, let AI , a line of indefinite length, represent one-half a revolution of the cam. At I draw the perpendicular

lar $I Q$ equal to the extreme throw, in this case $1\frac{1}{2}$ inch. As the rise of the follower is to be uniform, this action may be shown by a straight line connecting A and Q . Divide the line $A I$ into any number of equal parts, say eight, and erect perpendiculars at the points of division. The point E will then represent one-quarter revolution of the cam, and the distance $E M$ will represent the throw at that point. In the same way the distance $C K$ represents the amount of throw at one-eighth revolution, the distance $G O$, the throw at three-eighths revolution, and so on for the other perpendiculars.

To lay out the cam curve, describe about X , Fig. 2, as center any semi-circle, $a e i$. Divide this semi-circle into the same number of

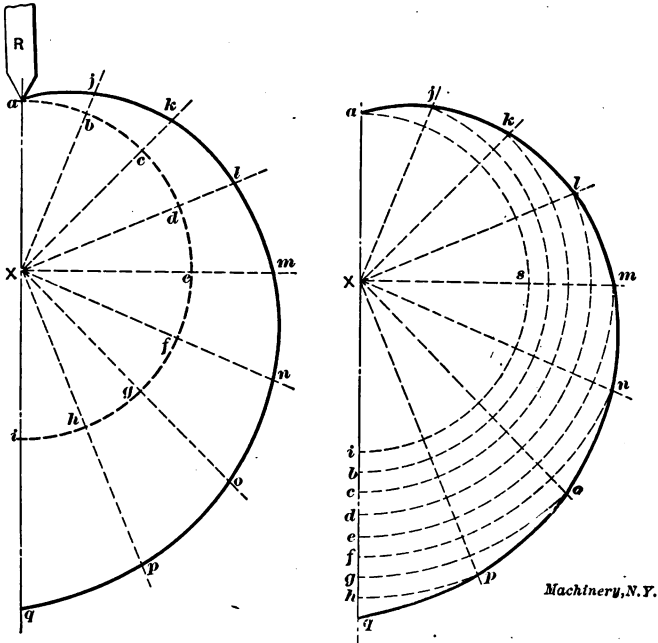

Figs. 2 and 3. Lay-out of Uniform Motion Cams.

equal parts into which the line $A I$ was divided. Connect these points of division with the center X , and extend the lines indefinitely beyond the semi-circle. On $X b$, make $b j$ equal to $B J$, on $X c$, make $c k$ equal to $C K$, and so on, extending each radius a distance equal to the corresponding perpendicular in Fig. 1. Then through the points a, j, k, l , etc., draw a smooth curve. This curve is one-half the required cam curve. By drawing a similar curve to the left of a the cam curve is completed. By rotating the cam about the center, X , the follower, R , would be forced to rise, with uniform velocity, through a distance of $1\frac{1}{2}$ inch. During the second half of the revolution it would fall uniformly, by aid of gravity or a spring, to the initial point a .

Alternative Method of Laying Out Cam Curve.

Another way of laying out the same cam curve is as follows: Draw any semi-circle, asi , Fig. 3, and extend the diameter on one side a distance iq equal to the required throw. Divide iq into any number of equal parts, as at b, c, d , etc., and divide the semi-circle by the same number of radii equally distributed. With X as center and a radius

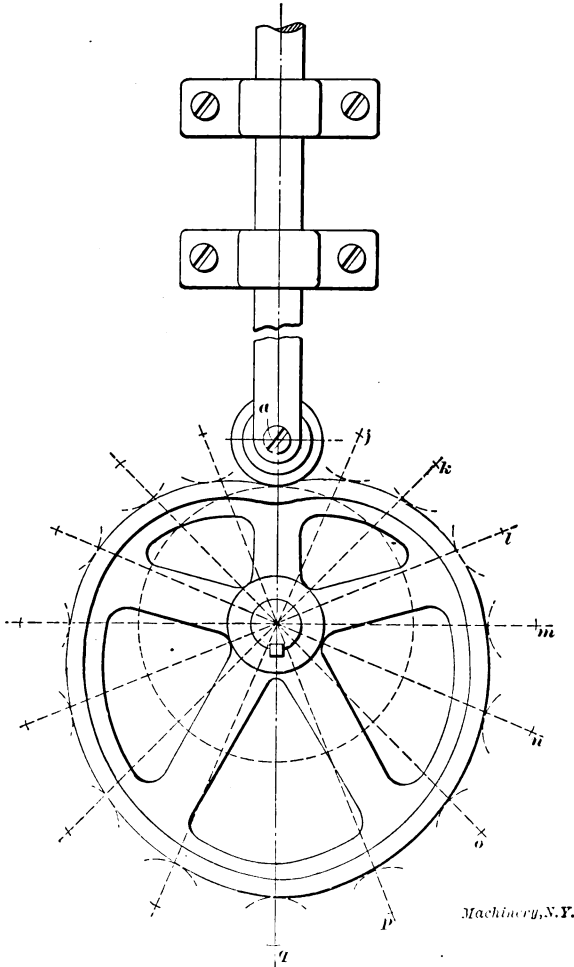

Fig. 4. Cam with Roller Follower.

equal to Xb describe an arc cutting Xj at j . With the same center and radius equal to Xc describe an arc cutting Xk at k . Continue this process through the points d, e, f , etc., thus obtaining the points l, m, n , etc. The latter are points on the required curve.

The excessive friction of a pointed follower such as that shown at R necessitates the employment of a follower that will reduce the

amount of friction to a minimum. A small roller meets this requirement. If a roller is employed as a follower the problem of laying out the cam curve becomes modified. A roller traveling along the curves shown in Figs. 2 and 3 would not impart to the follower-rod the desired uniform rise and fall. The variation would be but slight, yet sufficient to merit consideration where accuracy is desired.

Cams with Roller Followers.

Fig. 4 represents a heart-shaped cam of the same dimensions as in Figs. 2 and 3, but with a roller follower. It is the path of the center

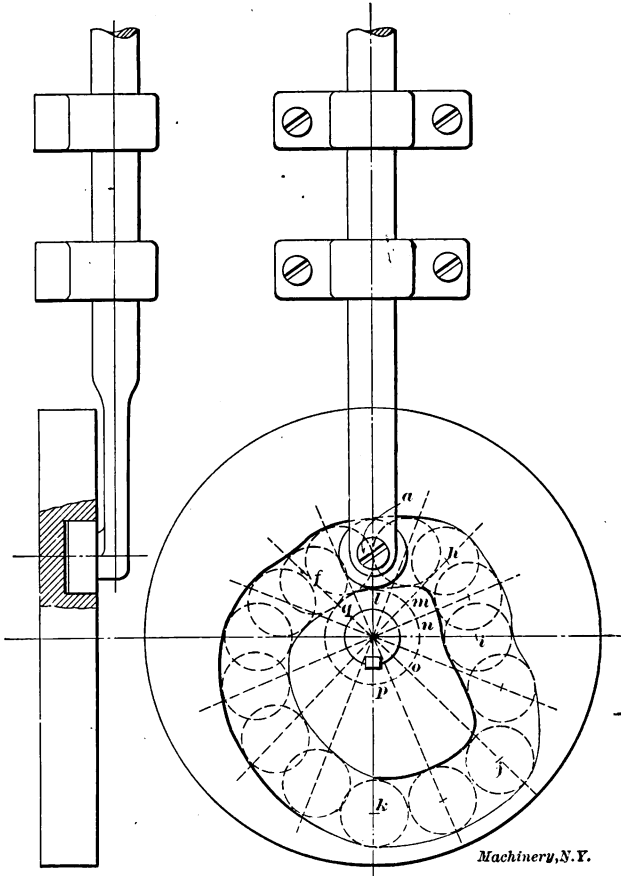

Fig. 5. Positive Action Cam for Variable Motion of Follower.

of this roller that requires the first consideration, as the position of this center regulates the throw. Therefore, the position of the center of the roller at various intervals in the rotation of the cam must be determined. This may be done by adding to each of the distances $J B$, $K C$, $L D$, etc., in Fig. 1, the radius of the roller, and thus obtaining

the points j, k, l , etc. With these points as centers and with radii equal to that of the roller, describe arcs. A curve drawn tangent to these arcs is the required cam curve.

This cam depends upon the action of gravity, or a spring, to keep the follower in contact with the driver. It can be made positive in action by the use of two followers placed at the extremities of the diameter of the cam, or by drawing curves tangent to both the top and bottom of the follower roller in its various positions, and the two curves taken as the boundaries of a groove cut into the metal. A familiar application of the use of a heart-shaped cam may be found in the bobbin-winder of the domestic sewing machine. The thread is fed to and fro at a uniform rate, the follower of the cam acting as a guide for the thread. The action is made positive by the employment of two follower rollers.

Positive Action Cam for Variable Motion of Follower.

The latter method of laying out a positive motion cam referred to above is more clearly shown in Fig. 5. A variable motion is here substituted for the regular motion of the heart-shaped cam. Let it be required to lay out a positive motion cam that shall impart to the

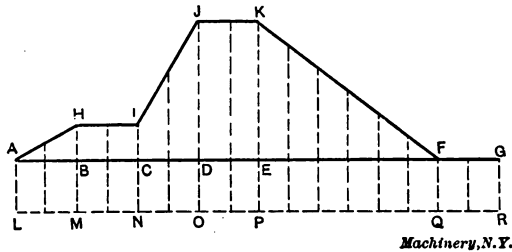

Fig. 6. Diagram of Motion Imparted to Follower by Cam in Fig. 5

follower the following action: A uniform rise of $\frac{1}{4}$ inch during the first eighth of a revolution; no action during the next eighth; a uniform rise of $\frac{3}{4}$ inch during the third eighth; no action during the fourth eighth; a uniform fall of 1 inch during the next three-eighths of the revolution; and no action during the last eighth. The action is graphically shown in Fig. 6. Let AG represent one complete revolution of the cam; B , the first eighth; C , the second; D , the third; E , the fourth; and F , the seventh. The problem calls for a uniform rise of $\frac{1}{4}$ inch during the first eighth. Therefore, from B draw the perpendicular BH , $\frac{1}{4}$ inch in length, and join A and H . As there is to be no action during the second eighth, draw HI parallel to BC ; that is, the follower will be the same distance from AG at I that it was at H , and therefore the follower will not have been acted upon. During the next eighth revolution the follower is required to move $\frac{3}{4}$ inch. As it has already moved $\frac{1}{4}$ inch, the sum of these two distances is the length DJ . As this rise is to be uniform, a straight line is drawn joining I and J . No action during the fourth eighth is shown by drawing JK parallel to DE . A uniform fall of 1 inch during the next

three-eighths of the revolution is shown by joining K and F , and the period of rest during the last eighth revolution is shown at $F G$. The line $A L$ is equal to the radius of the roller, and by drawing the line $L R$ parallel to $A G$, the distance of the center of the roller from the base circle may be taken directly for any radius of the cam.

To lay out the cam from the diagram, draw any base circle $l n p$, Fig. 5, and divide it into the same number of equal parts into which the line $A G$ is divided, viz., sixteen. Through these points of division

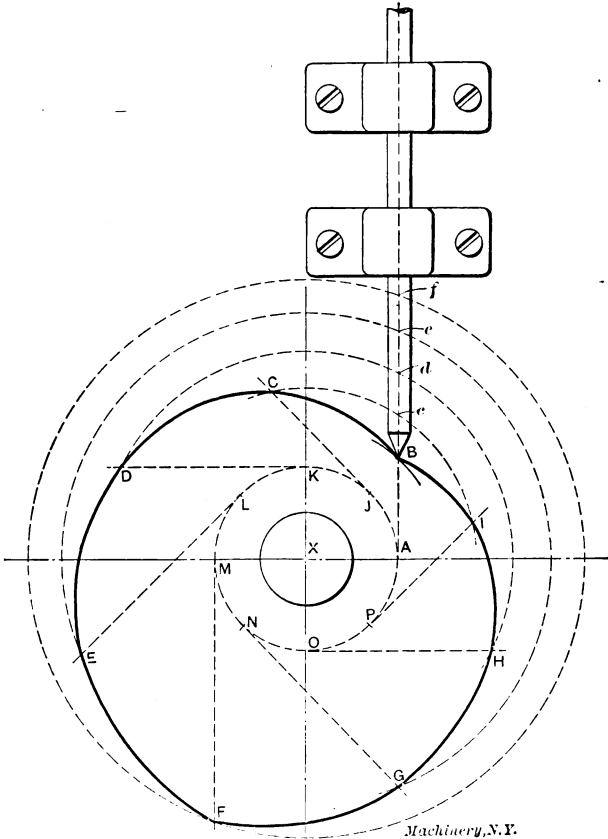

Fig. 7. Cam with Follower having Line of Action Eccentric with Cam Axis.

draw radii and extend them indefinitely. Upon these radii take $l a = L A$, $m h = M H$, $n i = N I$, etc., thus determining the positions of the center of the roller at the various intervals. Sketch in the outline of the roller in its different positions, and draw curves tangent to these outlines.

Line of Action of Follower Eccentric with Cam Axis.

In the cams previously considered, the line of action of the follower passes through the center of the cam-shaft. When the line of action

of the follower passes to either side of the center of the cam-shaft, as in Fig. 7, a different method of laying out the cam-curve becomes necessary. Assume that the requirements and conditions are the same as in Fig. 2, excepting that the line of action of the follower shall be one inch to the right of the center of the cam-shaft. Draw the indefinite line XA passing through the center of the cam-shaft. One inch to the right of X draw the line of action Af , of the follower, perpendicular to XA . Let B be the lowest position that the follower is to assume, and let f be the highest. Divide the throw, Bf , into any number of equal parts, as at c , d and e . Through A describe a circle with X as center. Divide this circle into twice the number of equal parts into which Bf is divided. From each of these points J , K , L , etc., draw tangent to the circle. Then, with X as center, describe arcs through c , d , e , and f . Where the arc c cuts the tangents from points

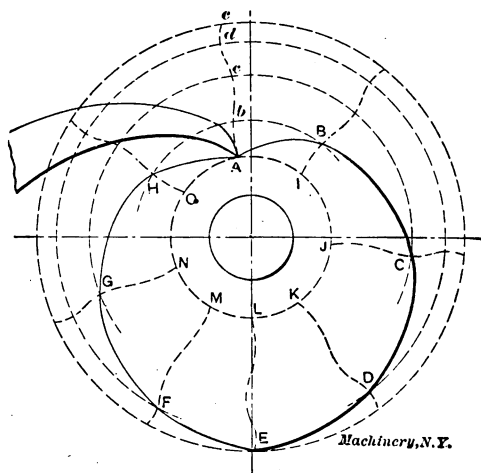

Fig. 8. Cam and Follower both having Variable Motion.

J and P , as at C and I , are points on the desired curve. Where the arc through d cuts the tangents from K and O , as at D and H , are also points on the curve. The points E , F , and G are obtained in a like manner.

Cams with Pivoted Followers.

The problem of Fig. 2 may be further modified by having the follower pivoted instead of acting in a straight line. In this case, the line of action becomes the arc of a circle. Problems of this nature may be solved by substituting for the straight line of action shown at iq , Fig. 3, an arc which shall represent the path of the follower. This arc of action takes the place of all the various radii of Fig. 3, and the points b , c , d , etc., serve as a series of initial points from which to swing concentric arcs to intersect the various positions of the arc of action of the follower. The method is analogous to that of Fig. 3. In Fig. 29 this method is applied to a cam of ununiform motion.

Cams and Followers both having Variable Motion.

The rotation of the driver has thus far been considered as uniform, and the action of the follower either uniform or irregular. A case will now be considered wherein both the action of the driver and that of the follower is irregular. In Fig. 8, let the unequal divisions into which the base circle $A J L$ is divided by the points A, I, J , etc., represent space traversed by the driver in equal periods of time. That is, if it takes the driver one second to rotate through the arc $A I$, it will take the same time to rotate through the larger arc $I J$ or the smaller arc $L M$. Again, let $A e$ represent the irregular path of the follower and the points b, c, d , and e its position at certain equal intervals of time. The number of divisions made in the path

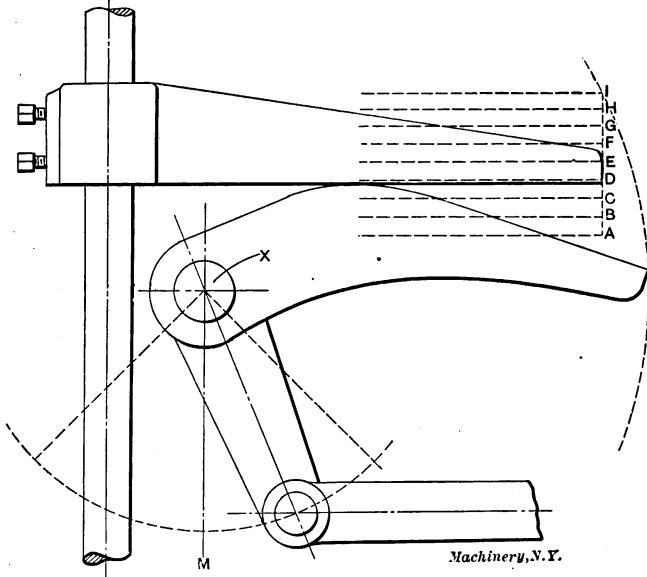

Fig. 9. Cam with "Flat-footed" Follower.

of the follower should correspond with the number of divisions into which one revolution of the driver is divided. The points B, C, D , etc., of the cam curve may be found by the method of intersections explained in Fig. 3. This problem is of a general nature and is universally applicable to problems involving a disk driver and a follower other than a flat-footed one.

The "Flat-footed" Follower.

A familiar example of a flat-footed follower is afforded by the toe-and-lift mechanism used to actuate the engine valves of side-wheel steamers. The "lift" or "wiper" is pivoted upon a rock-shaft, which is caused to oscillate by an eccentric placed upon the paddle-wheel shaft. In Fig. 9, let the arc through which the rock-shaft swings equal 90 degrees—45 degrees on either side of the vertical—and let

the "toe" rise and fall with uniform motion through $1\frac{1}{2}$ inch. It is required to design the upper face of the lift to give the desired throw.

Divide the throw, AI , into any number of equal parts, say eight, and locate the center of the rock-shaft, as X . Upon a piece of tracing paper draw a quadrant, xhk , Fig. 10, xk being equal to one-half the throw of the eccentric, say 3 inches. Draw xl at 45 degrees to xh , and kl at right angles to xk . Through the point of intersection, l , and with x as center, describe the arc lm . The arc kh then represents a quarter revolution of the eccentric, and the arc lm the corresponding angular movement of the rock-shaft crank. Divide the arc kh into the same number of equal parts into which the throw of the toe was divided, *viz.*, eight. Through these points of division draw lines parallel to xm , intersecting the arc ml in the points n, o, p , etc. From these points draw radial lines. Now, while the eccentric is moving through a quarter revolution with a uniform motion, as

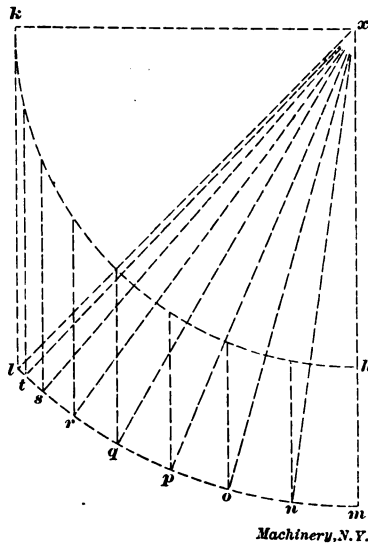

Fig. 10. Layout for Cam with "Flat-footed" Follower.

shown by the equal division of the arc kh , the center line of the rock-shaft crank will assume the corresponding positions shown by the radial lines.

Place the tracing in Fig. 10 upon Fig. 9 so that X and x coincide, and the line xm falls upon the line XM . Then draw upon the tracing-paper the position of the line A . Rotate the tracing-paper about X until xn coincides with XM and draw the position of the line B . Again rotate about X until xo coincides with XM and draw the position of the line C . Continue this process until the positions of the lines D, E, F , etc., are located. A curve drawn tangent to the lines thus obtained is the required cam-curve. This latter procedure is not shown in the cuts. The use of tracing-paper for laying out cam-curves, as here

exemplified, is applicable to the laying out of a variety of such curves. The tracing may be made to assume different positions of either the driver or follower and their relation shown at any desired interval during their action.

In work dealing with cam curves there are some factors of a practical nature that must be considered, one of which may be here stated, as applying directly to the problem of the toe-and-lift. This factor is the easement of cam action to prevent jerking. The action as drawn in Fig. 9 has too abrupt a beginning and ending, and should be modified by an easement curve at both these points of action. In any action that tends to jerkiness, a smoother motion may be obtained by slightly modifying the curve at the offending point.

Cams with Double Contact.

In the drawings of cams thus far shown, there has been but one point of contact between the driver and follower. Positive motion is often obtained by having two points of contact. Cams having two such

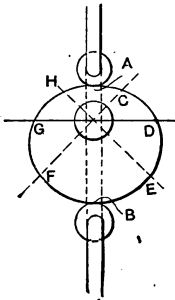

Fig. 11.

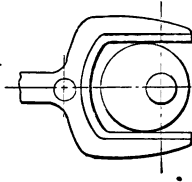
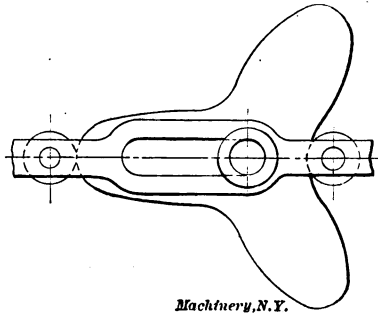

Fig. 12.



Machinery, N.Y.

Fig. 13.

points of contact are subject to certain limitations. For instance, in Fig. 11, if A and B are two points of contact of the follower, and are a constant distance apart, and the curve $A D B$ be any assumed curve of one-half revolution of the cam, the curve of the remaining half revolution is limited to a curve complementary to $A D B$. That is, the distances $C F$, $D G$, and $E H$ must equal the constant $A B$.

If it is desired to have an independent movement throughout the entire revolution of the cam it will be necessary to have two cams placed one upon the other, one point of contact of the follower bearing upon the second cam. In this case, having assumed any curve for one of the cams, the other cam must be made complementary to the first, the constant distance apart of the points of contact forming the basis for the calculation. Forms of double contact cams are shown in Figs. 12 and 13. Fig. 12 is a rocker cam, and Fig. 13 is a tri-lobe cam giving three reciprocating motions to the follower for each revolution of the driver.

Cylindrical Cams.

Fig. 14 illustrates a method for laying out cylindrical cams. Let $g d a$ be the plan, and $H a'$ the development of the cylinder shown

in elevation at KA . Divide the plan into any number of equal parts as at a, b, c , etc., and project these points of division upon the front elevation of the cylinder as the elements A, B, C , etc. On the developed surface these elements appear as a', b', c' , etc. Upon the development, lay out the desired action, as in Figs. 1 and 6, avoiding or easing all sharp corners. Suppose mip to be such an action. This curve will then represent the path of the center of the follower. Let L indicate the center of the follower. Then, as the cylinder is rotated about its axis, the point L moves to and fro a distance LI , and with an irregular motion dependent on the form of the curve mip . The projection of this curve upon the elevation of the cylinder is shown at Lm .

The form of the roller-follower may be either cylindrical or conical; the question of the shape of the follower has been treated more completely in Chapter IV. In laying out the cam practically, the outline of the groove may be drawn by the method shown in Fig. 5, that is,

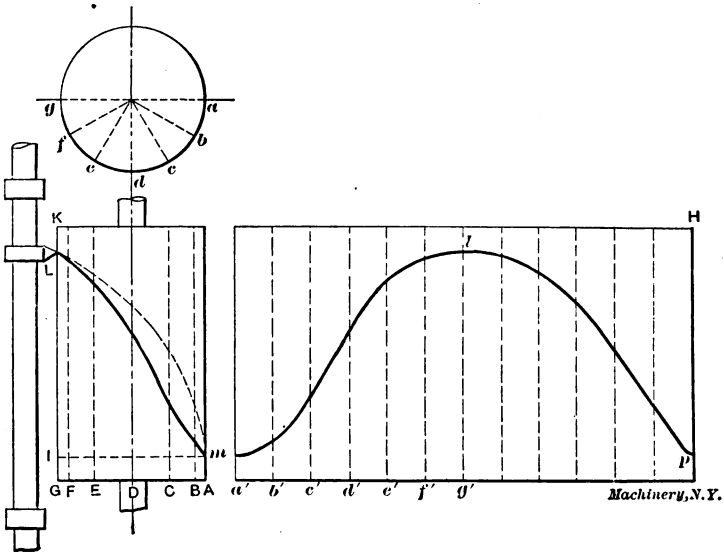

Fig. 14. Layout of Cylindrical Cam.

by drawing curves tangent to the various positions of the roller, and then, by winding the drawing about the metal cylinder blank, any number of points of the groove may be located with a prick-punch. Or, the drawing may be made directly upon the surface of the cylinder.

The method for laying out a conical cam is similar in principle to that for laying out a cylindrical cam, and is easily deduced from the latter.

Laying Out a Cam for Shifting Planer Belt.

The following problem in machine design is one of a series given to the students in mechanical engineering at Cornell University. It furnishes a good example of the method of reasoning applied to practical problems in mechanics, and is also an interesting problem in

quick-return motions. The problem calls for the designing of a device for automatically shifting the belts of a planer. The driving shaft has a fixed pulley of wide face carrying two belts. The driven shaft has two sets of a loose and a fixed pulley. One set, smaller than the other, is driven by a crossed belt, and its shaft therefore rotates in a direction opposite that of the driving shaft. The larger fixed pulley

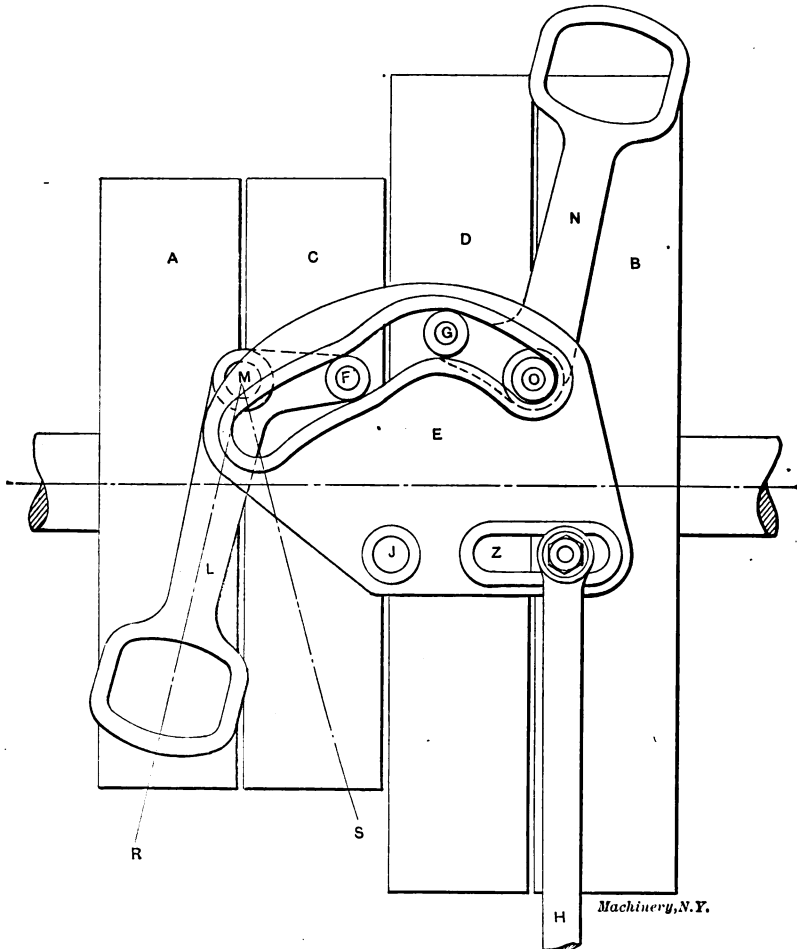

Fig. 15. Arrangement for Automatically Shifting Planer Belts.

drives the planer while the tool is cutting, and the smaller fixed pulley causes a quick return of the tool while no work is being performed.

The shifter should be placed near the driven pulleys so as to operate each of the belts at its point of approach to its pulley, and to operate each belt separately. The shifter must also be operated automatically by the to-and-fro motion of the bed of the planer, and be capable of

adjustment to allow for the variation of the momentum of the machine under different loads.

In Fig. 15, *A* and *B* are the two loose pulleys of the driven shaft, and *C* and *D* the fixed pulleys. *E* is a grooved cam rotating about *J*, and having two roller followers *F* and *G*. *H* is a link driven to and fro by a tripping device attached to the planer bed. *L*, the shifter-arm for the smaller pulleys, is a crank rotated by the follower *F* about *M* as a center. In a similar way, the crank *N* rotates about *O*. The pivots *J*, *M* and *O* are carried on a plate made fast to the planer and not shown in the drawing. The portions of the cam to the left of *F* and to the right of *G* are arcs of circles with *J* as a center, and there-

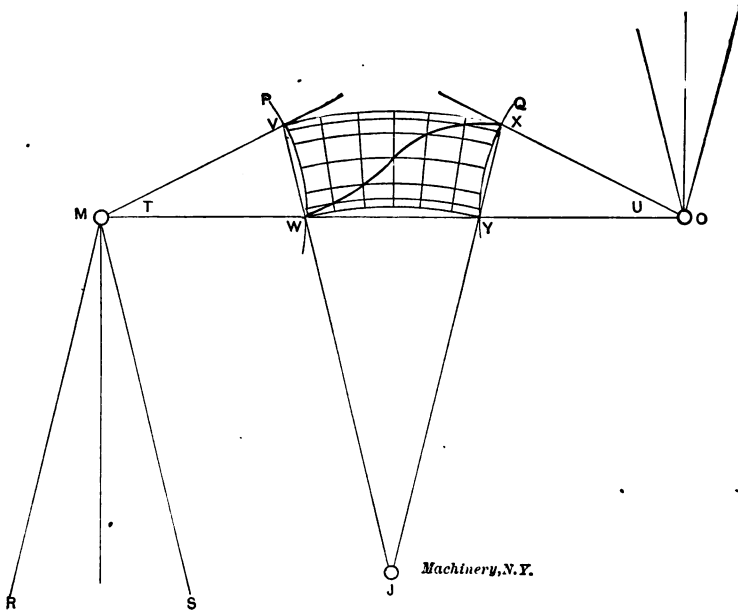

Fig. 16. Layout of Cam Curve for Cam in Fig. 15.

fore, while either of the followers is traveling through these arcs there will be no movement of the shifter-arms. The throw of either of the arms is occasioned by its follower traversing the irregular path between *F* and *G*.

Imagine the link *H* drawn downwards. The cam then rotates towards the right about the center *J*. The follower *F* is held fixed in its position by the arc of the cam to its left, and therefore the shifter-arm *L* remains stationary. The path of the follower, *G*, however, is through the irregular part of the cam between *F* and *G*, which causes it to rotate about *O* as a center, thereby shifting the arm *N* from the loose pulley *B* to the fixed one *D*. If the link *H* is operated in the reverse direction to that imagined above, the shifter-arm *L* will then become the active member, and the shifter-arm *N* will remain inoperative.

A method for determining the irregular path of the centers of the followers F and G is shown in Fig. 16. First locate the points M and O from Fig. 15, and draw the circular arcs P and Q , the paths of the centers of the followers F and G . Then draw R and S , the extreme positions of the center line of the shifter-arm L . Make angles T and U equal to the angle formed by the lines R and S . Divide the line through VW into six parts proportional to 1, 3, 5, 5, 3, 1, and through the points of division draw arcs with J as a center. Divide VX into six equal parts, through which draw radial lines. The successive intersections of the circular arcs and the radial lines determine the paths of the followers F and G , as WX . Lines drawn tangent to successive positions of a follower along the line WX will be the outline of the cam-slot at its irregular part.

The slot Z , Fig. 15, permits adjustment of the link as called for in the conditions of the problem. The center of the opening for the belt in the shifter-arm L is placed nearer to the center line of the shaft to allow for the angularity of the cross belt.

CHAPTER II.

CAM CURVES.

When the curve of a cam is not determined by a given definite motion of the follower, and the condition presented to the designer is simply to make the follower move through a given distance during a given angle of motion of the cam-shaft, the ease and silence with which the cam works depends upon the character of curve used in laying out the advance and return. The uniform motion curve, the simplest of all curves to lay out, is a hard-working curve, and one that cannot be run at any great speed without a perceptible shock at the beginning and end of the stroke.

Uniform Motion Curve.

The uniform motion curve would be represented in a diagram by the diagonal of the rectangle of which the base represents the angle of motion, and the altitude, the stroke of the cam, as shown by the full lines in Fig. 17. However, should the nature of the design demand a uniform motion for a given part of the revolution of the cam-shaft, the shock at beginning and end of stroke may be modified by increasing both the angle of motion and the stroke, and, in the diagram, filling in arcs of circles as shown by the dotted lines in Fig. 17. The amount of curvature at the ends of stroke is dependent upon the amount it is possible to increase the angle of motion, and the centers of the arcs are determined by drawing perpendiculars to XY as shown in Fig. 17. It will be noticed that the uniform motion has been maintained for the original angle, the modifications at the ends caus-

ing the increase of angle of motion and of stroke, the rectangle formed by these two being shown by dotted lines. Even with these modifications the cam is still apt to work hard, especially if the angle of motion is small.

Harmonic Motion Curve.

The crank or harmonic motion curve works much more easily than the uniform curve, and a cam laid out with this motion may be run

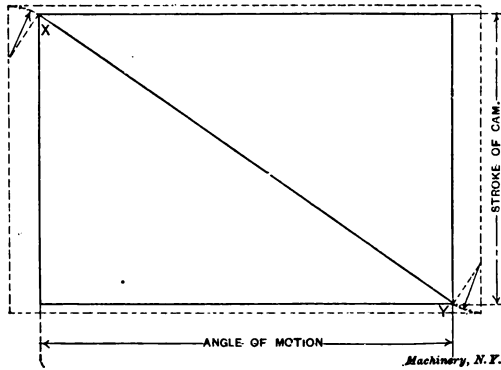

Fig. 17. Uniform Motion Curve.

at a high speed without much shock or noise. To draw a diagram of this curve, draw a semi-circle having a diameter equal to the stroke of the cam, and divide this semi-circle and the line representing the

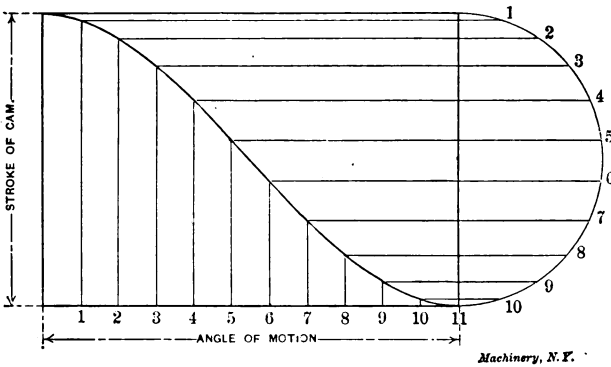

Fig. 18. Crank or Harmonic Motion Curve.

angle of motion into the same number of equal parts. The intersection of lines drawn from these divisions will give points on the curve. Fig. 18 shows the harmonic curve and the manner in which it is obtained.

Gravity Curve.

Probably the easiest working cam curve is the one known as the gravity curve. This curve has a constant acceleration or retardation bearing the same ratio to the speed as the acceleration or retardation

produced by gravity; hence its name. A body falling from rest will pass through about sixteen feet in one second (more accurately 16.09 feet). During the next second the body will increase its velocity by about thirty-two feet, making the distance covered during the second second forty-eight feet; during each succeeding second the body will gain in velocity thirty-two feet. Using sixteen feet as a unit of measurement, it will be seen that a body would travel through units 1, 3, 5, 7, 9, etc., during successive seconds or units of time. To apply this motion to the cam curve, we might divide the angle of motion into a given number of equal parts and, using the units given above, we

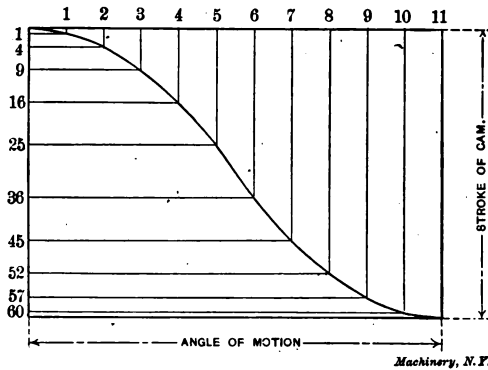

Fig. 19. Gravity Motion Curve.

may increase the velocity to a given maximum and then, retarding with the same ratio, bring the follower again to rest at the other end of the stroke. In the diagram, Fig. 19, the line representing the angle of motion is divided into eleven equal parts which necessitates eleven divisions on the line representing the stroke of the cam. If the motion for the first part of the stroke is to have a constant acceleration, as referred to above, the distance traversed by the follower during the first part of the angle of motion would be one unit; in the second part, three units; in the third part, five units, and so on until the maximum velocity has been reached which would be during the

Number of period.	Distance traversed by Follower during one period.	Total distance traversed since beginning of Motion.
1	1	1
2	3	4
3	5	9
4	7	16
5	9	25
6	11	36
7	9	45
8	7	52
9	5	57
10	3	60
11	1	61

sixth part of the angle of motion when the follower would travel through eleven units of motion. At this point the motion would begin to be retarded by a constant deduction which would cause the follower

to move through nine units during the seventh interval of time, seven units during the eighth, five units during the ninth, three units during the tenth, and one unit during the eleventh and last interval. The sum of these units is sixty-one, which will necessitate dividing the line representing the stroke of the cam into sixty-one equal parts of which the first, fourth, ninth, sixteenth, twenty-fifth, thirty-sixth, forty-fifth, fifty-second, fifty-seventh, sixtieth, and sixty-first will be used for determining points on the curve. The combination of the table given and the diagram shown in Fig. 19 will show how the gravity curve may be drawn.

Approximation of Gravity Curve.

A very close and satisfactory approximation for the gravity curve, and one that entails less work than the theoretical, is shown in Fig. 20. The method of drawing is similar to the one used for the harmonic motion, excepting that an ellipse takes the place of the semi-circle. It can be seen very readily that the ratio of the major and minor axes will determine the character of the cam curve. To obtain

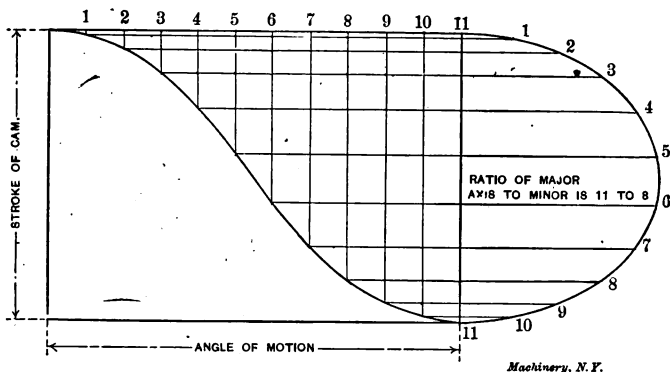

Fig. 20. Approximate Gravity Curve.

a curve that will approximate the gravity curve, the line representing the stroke of the cam should be used as the minor axis and the ratio of major axis to minor axis should be $1\frac{1}{2}$ to 1 or 11 to 8. Dividing the semi-ellipse and line of angle of motion into the same number of equal parts, and projecting, we obtain points on the curve. Fig. 21 is given so that a comparison may be made of the three motions given above when applied to the same cam.

Laying Out Cams for Rapid Motions.

As already mentioned in Chapter I, we may consider a cam mechanism as being made up of two elements. As generally constructed, one element is a revolving plate, cylinder, cone or sphere, and the other element is a bar or a roller which has some form of reciprocating motion. The revolving piece is usually made the driver, although the mechanism may be made to work in the reverse order. The shape of a cam will depend upon the kind of motion that the follower is required to have. The motion of cams that are used for driving parts of

machinery may be, as we have already seen, one of three kinds, *viz.*:

1. *Uniform motion*, in which the follower is made to pass over equal spaces in equal intervals of time.

2. *Simple harmonic motion*, in which the follower is accelerated from rest to a maximum velocity and then retarded again to a state of rest, following the harmonic cycle.

3. *Uniformly accelerated motion*, in which the follower is accelerated from rest to a maximum velocity and then retarded again to a state of rest, the acceleration being uniform, as, 1 inch per second, 2 inches per second, etc.

To this we may add a fourth kind frequently met with:

4. *Intermittent motion*, periods of motion being interrupted by periods of rest.

In slow-moving machinery it may not be important whether the follower moves with uniform, simple harmonic, or uniformly accelerated motion, but in machines where the cams have a high rotative speed, and the follower a reciprocating motion, as in the case of sewing machines and in some textile machinery, a uniform rate of motion will

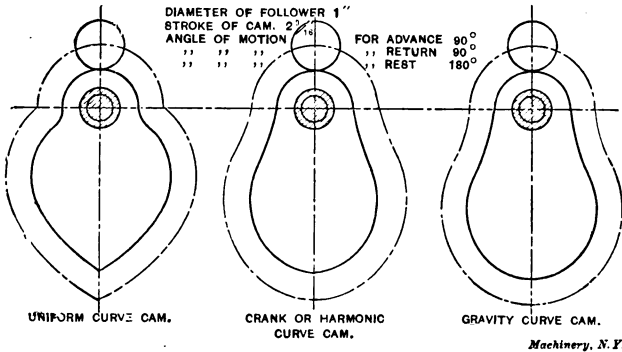

Fig. 21. Comparison between the Different Cam Constructions.

be unsatisfactory or impossible. The reason for this is that the follower is impelled from rest to its maximum velocity instantly, and also brought to rest from a maximum velocity instantly. This gives it a sudden jerk at each end of the motion, which is very trying to a machine when the reversals take place rapidly. Cams for high rotative speeds, where the follower has a reciprocating motion, should, therefore, be so designed that the follower will start gradually, attain its maximum speed near the middle of its path, and then gradually come to rest. In other words, the follower should have a uniformly accelerated motion during the first half of its movement, and a uniformly retarded motion during the last half.

In uniformly accelerated motion $S = \frac{1}{2}Pt^2$, where S = the distance passed over, P = the acceleration, and t = the time. This is the same as saying that the distance which the body has passed over at the end of any number of units of time varies as the square of the number of such units. For example, if a body has a uniform acceleration of 2

inches per second, $S = \frac{1}{2} \times (2) \times (1)^2 = 1$ for the first second; $S = \frac{1}{2} \times (2) \times (2)^2 = 4$ for the next second; and so on. This is, as said before, also the law of falling bodies whose motion is not resisted by the air or other medium. Uniformly retarded motion obeys the same law. If the time intervals of such a motion be plotted as abscissas and the corresponding space intervals as ordinates, with reference to co-ordinate axes, the resulting curve will be a parabola, and this is the curve that should be used for the outline of cams that are designed for high rotative speeds.

Uniform Motion Cylinder Cam.

The cams shown in the following cuts do not necessarily represent any existing forms; they simply illustrate how the principle may be applied to certain shapes of cams and paths of followers. In Fig. 22, lay out on a sheet of paper $ABDC$ a line constructed as follows: Bisect CD at M and divide CM into any convenient number of parts, say five. Lay off on CA any distance ST , and divide ST into the same number of parts as there are in CM . Through the points 1, 2, 3, etc., on CM , erect perpendiculars to CM , and through the points 1₁, 2₁, 3₁,

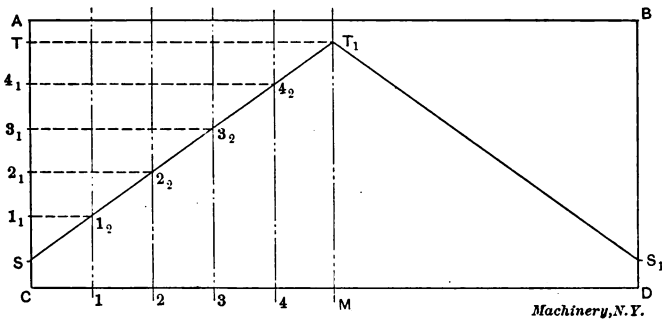

Fig. 22. Development of Uniform Motion Curve.

etc., on CA , draw parallels to CM intersecting the perpendiculars at points 1₂, 2₂, 3₂, etc. A line ST_1 drawn through these intersections will be straight. The line T_1S_1 can be found in the same way. Now if the sheet of paper $ABDC$ be wrapped around the outside of a cylinder whose circumference is equal to the distance CD , the line ST_1 will take the position ST , Fig. 23, and the line T_1S_1 will form a similar curve on the reverse side of the cylinder. If this curve be made the center line of a groove, as the cylinder revolves on its axis, the groove will drive a follower up and down, parallel to the elements of the cylinder, with a uniform speed. The follower will start and stop at either end of its motion with a sudden jerk.

Uniformly Accelerated Motion Cylinder Cam.

In Fig. 25 let $ABDC$ represent the paper as before. Bisect CM at 3, and ST at 9. Divide $C3$ and $3M$ into any convenient number of parts, say three; then divide $S9$ and $9T$ into the square of three parts, or 9, as shown. Erect perpendiculars to CM at the points 1, 2, 3, etc., and draw parallels to CM through the points 1, 4, 9, 4₁, and 1₁. Through

the points S and T , and the intersections $1_1, 2_1, 3_1, 2'_1$ and $1'_1$, draw a smooth curve. This line will be a parabolic curve, reversing at 3_1 . The curve T_1S_1 is constructed in the same way. Now wrap the sheet of paper $ABDC$ around a cylinder whose circumference is equal to CD . The curve will take the position ST_1 , Fig. 26, and the curve T_1S_1 will take a similar position on the reverse side of the cylinder. A groove made with these curves as center lines will drive a follower P up and down through the distance K , as the cylinder is rotated on its axis. The follower will start gradually at S , attain its maximum velocity, and then come gradually to rest again at T_1 , the motion being

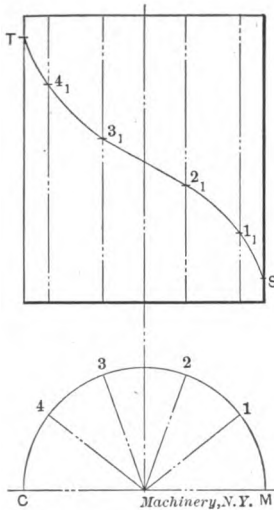

Fig. 23. Uniform Motion Curve scribed on Cylindrical Surface.

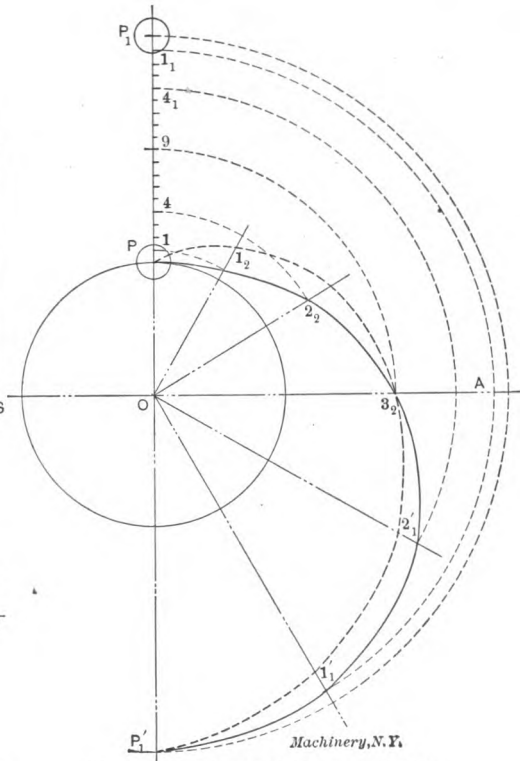

Fig. 24. Accelerated Motion or Gravity Curve applied to Plate Cam.

uniformly accelerated and retarded. The sides of the groove are made parallel to ST_1 , and drawn to suit the diameter of follower P .

Fig. 27 shows the distortion of the curve ST when the follower moves in the arc of a circle, with center at some point Q , instead of in a straight line. Points on the new curve are found by setting off from the intersections b_1, d_1 , etc., the ordinates ab and cd . The curve $S a_1 T$ is then made the center line of a groove which will drive the hinged follower with the same variation in speed attained by the follower in Fig. 26.

Accelerated Motion Plate Cam.

Fig. 24 shows how the parabolic curve is applied to a plate cam. The roller follower is supposed to oscillate between P and P_1 as the cam rotates about O . The curve P_3P_1' corresponds to ST_1 in Fig. 26, being the center line of the parabolic groove in the face of the plate.

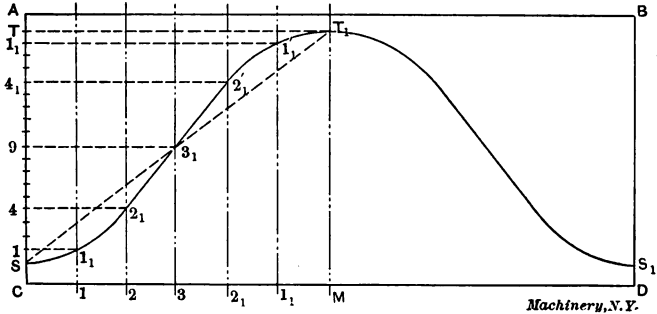

Fig. 26. Development of Uniformly Accelerated Motion Curve.

Only one-half of the cam is shown in the figure. Suppose this cam is to rotate 180 degrees, while the follower moves from P to P_1 . Draw the base circle with radius OP , the length of which will depend upon the size of the cam. Draw OA perpendicular to OP , and divide the arc subtended by POA into any convenient number of parts, say three. Draw radii $O1_1, O2_1,$ etc. Divide PP_1 into two equal parts at 9 , and divide $P9$ into the square of three parts, or 9, as shown. With O as a

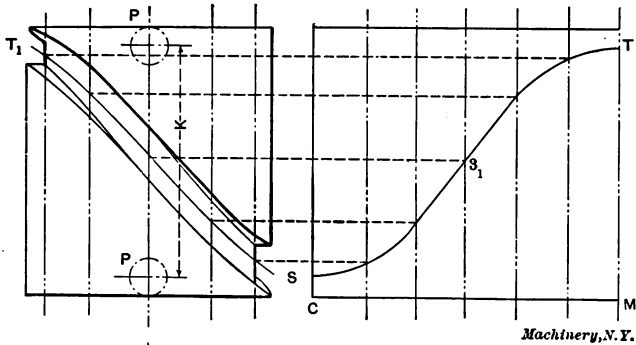

Fig. 26. Transferring Uniformly Accelerated Motion Curve to Cylinder.

center, and radius $O1_1$, find the intersection 1_2 . In the same way find the other intersections $2_2, 3_2,$ etc., and draw a smooth curve through these points. This curve has the same relation to the curve of uniform

motion shown dotted, that the parabolic curve has to the straight line in Fig. 25. If a similar curve be laid out on the other side of PP_1' , and made the center line of a groove, then the follower P will be pushed up and down mechanically by direct contact. If a curve parallel to P_3P_1' , and drawn at a distance equal to the radius of the follower away from

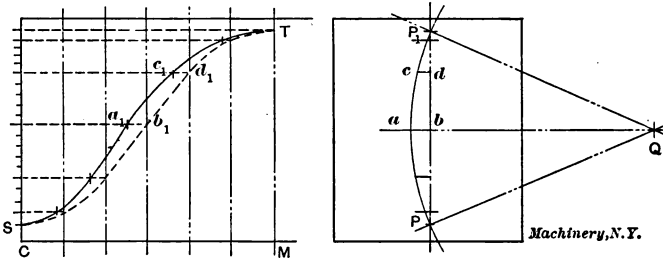

Fig. 27. Accelerated Motion Curve, when Follower moves in the Arc of a Circle.

it, on the inside, be made the outline of the cam, then the follower will be pushed up mechanically to P_1 , and allowed to fall by its own weight. It will remain in contact with the cam theoretically, because the principle of uniformly accelerated motion is the same as that of a falling body. In practice, however, the friction and the inertia of the connected

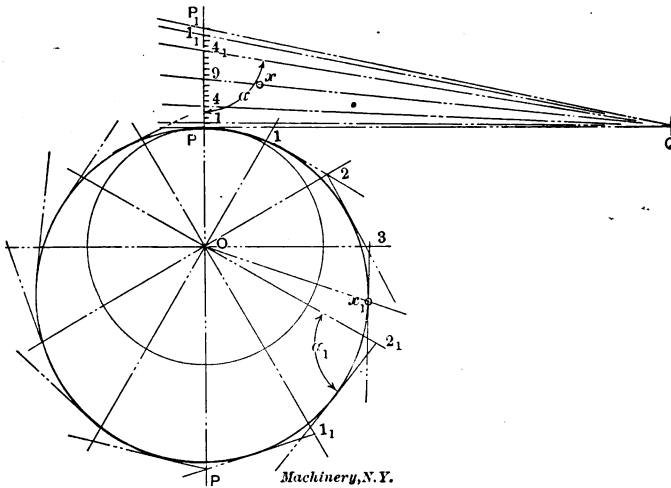

Fig. 28. Plate Cam for Bar Follower.

parts would probably prevent the follower from remaining in contact with the cam on its return motion if the oscillations were rapid.

Fig. 29 shows the parabolic cam constructed for a follower which moves in any curved path. The construction is the same as in Fig. 24 except that points on the curve are located on radial lines Oa_1, Ob_1 , etc., offset from the first radii by the distances $2a_1 = 4a, 3b_1 = 9b$, and so on.

Plate Cam with Bar Follower.

When a plate cam is to be laid out to drive a bar follower through a certain cycle of operations, the construction is more complicated. The base circle is divided as in the previous case into any convenient number of parts, and the square of the number of such parts laid out from P to 9 and from 9 to P_1 , Fig. 28. If the bar is to oscillate about Q as a center, it will take the positions $Q1$, $Q4$, $Q9$, etc., as the radii $O1$, $O2$, $O3$, etc., come to the position OP . The intersections 1, 2, 3, and so on, are found just the same as in the previous cases. Now instead of drawing the curve for the cam outline through these points, straight lines which represent the edge of the follower must be drawn

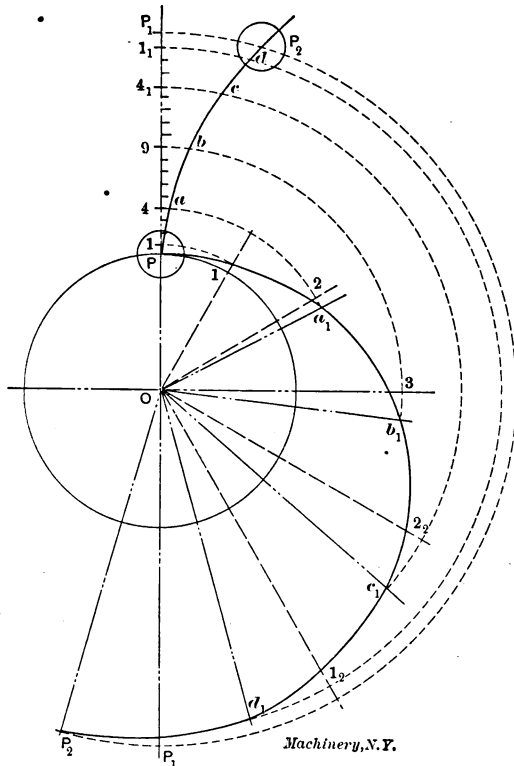

Fig. 29. Accelerated Motion Curve applied to Plate Cam, with Follower moving along a Curve.

through the points making the same angle with a given radius as the follower makes with OP when the radius in question is in the position OP . For example, angle α equals angle α_1 . Now the cam outline is a smooth curve drawn tangent to these straight lines. If the bar follower, instead of being centered at Q , moves up and down parallel to its first position, then all these angles are right angles. If the face of the bar is curved, then the cam outline must be drawn tangent to the

curves after they have been properly located with respect to their several radii.

In drawing cams like Fig. 28, the proper relation between the diameter of the base circle and the distance PP_1 must be assumed. If the base circle is too small, the cam outline will not be tangent to the edge of the follower in all positions, and the latter will not have uniformly accelerated and retarded motion. There is a rolling and sliding contact between the cam and its follower in the case of Fig. 28. The rolling action tends to carry the point of contact outward to the right of OP , during the upward motion, and to bring it back towards OP during the downward motion. The point of contact x does not necessarily occur when Ox_1 is perpendicular to Qx .

Effect of Changing Location of Cam Roller.

When the line of motion of a follower passes through the center of rotation of the cam, and the angle of the curve causes it to work hard,

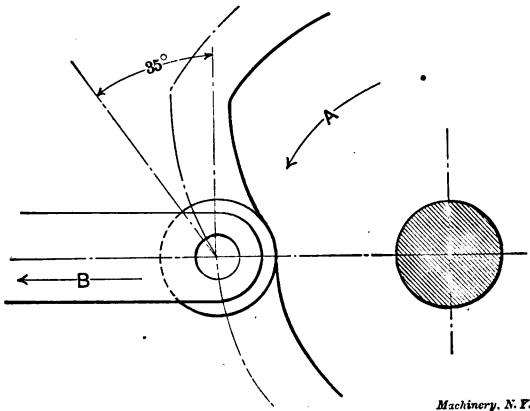

Fig. 30. Cam Roller on Center Line of Cam.

the curve may be modified, and the same motion of follower obtained by placing the follower with its line of action parallel to its original position and not passing through the center of the cam. A condition may be assumed, as shown in Fig. 30.

Here we have a cam, rotating in the direction indicated by the arrow A , whose duty it is to move the follower $\frac{3}{4}$ inch in the direction indicated by the arrow B during a 30-degree angle of motion of the cam-shaft. The angle of the cam as presented to the follower at the beginning of the stroke would be 35 degrees, as determined by the tangent to the curve of the centers, as indicated on the drawing. After the follower had moved one-third of its distance, the angle presented would be 32 degrees, and when two-thirds of the travel had been made, the angle of the curve would be about 30 degrees. The angles given are for a curve which would give a uniform motion to the follower. Should the cam curve work hard at the required speed we would naturally make the cam of greater diameter, if possible, which would reduce the

angle of the cam, as shown by the difference in the angles presented in Fig. 30, as we go out from the center of rotation. The design of the machine, however, might make this change impossible. If it was simply necessary to get the follower from the position shown to a point $\frac{3}{4}$ inch distant in a 30-degree movement of the camshaft, without regard to its motion, a harmonic or gravity curve might be used which would cause the cam to work easier. However, this would be impossible should our design require a uniform, or some other equally hard motion. A third way in which the angle of the curve might be decreased would be to make the angle of motion of the camshaft greater. This, too, might be made impossible by the limitations of our design.

Another way, and one not commonly used, consists in changing the location of the cam roller. In Fig. 31 all conditions are the same as

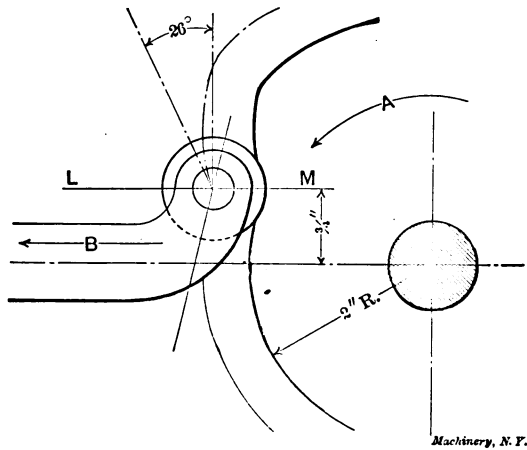

Fig. 31. Cam Roller placed above Center Line of Cam.

in Fig. 30, except the roller has been placed $\frac{3}{4}$ inch above the line passing through the center of the cam. The center of the roller will now pass along the line LM , or parallel to the line of motion in Fig. 30. The angle of the curve presented to the roller in this case is 26 degrees, much less than the angle presented in Fig. 30, and the angle decreases as the roller moves away from the center of rotation. The advantage that may be gained by moving the cam roller may be readily seen by comparing the results given above. There is, of course, a limit to the distance the roller may be changed, for if placed too far away from the center line, the thrust in the direction at right angles to the direction of motion of the follower would be so great as to offset the advantage gained.

Even without the aid of an illustration it may be seen that to place the cam roller on the other side of the center would cause the angle of the cam curve to increase, thus making conditions worse. The offset of the roller should be in the direction opposed to the direction of motion of the cam.

CHAPTER III.

NOTES ON CAM DESIGN AND CAM CUTTING.

It is strange that the processes and methods of cam cutting have not been improved more rapidly than they have. Twenty-five years ago, cams and gears were on about an equal footing; that is to say, most of both were cast to as nearly the proper shape as possible, after which the working surfaces or teeth were smoothed up with a file, and then the holes and hubs were finished in the usual manner. Some cams of both plate and barrel forms were cut, with suitable attachments, in the same machine the gears were cut in. This was an old hand indexing machine, with an automatic feed composed of a weight hung on the pilot wheel. Since that time gear cutting machinery has been wonderfully developed. All sorts of styles and arrangements are on the market, meeting every demand, from that for a general purpose machine to highly specialized forms. When it comes to cam cutting machinery, however, while machinery builders have special tools for their own work, so far as the writer is aware, there is no tool regularly on the market for cutting cams. The cam has thus fallen behind the gear in the process of development. Machine designers and machine users are liable to be a little suspicious of cams, anyway. Considerable trouble is often taken to avoid the necessity for using them. This is due, however, as much to faulty design and faulty construction as to any inherent objections to this form of mechanical movement. It is here proposed to call attention to some of the points to be considered in designing and producing satisfactory cams, with the thought of thereby doing something to justify a more extensive use of them.

Faults in the Design of Cams.

We have all seen cams that were the cause of a good deal of profanity, in which the trouble could be traced to the designer or machinist, who laid out the curves on what might be termed "schedule time"; that is to say, he simply made sure of his starting and stopping points, neglecting all intermediate points so long as the movement got there and got back on time. This, he thought, would be all that was necessary, not taking into account the shock and jar caused by the sudden starting and stopping of heavy slides, levers, etc., at even moderate speeds. The temptation to do this is always strong, especially in the case of barrel cams, where it is so much easier to use the milling machine (gearing it up for a spiral to meet the schedule requirements) than it would be to lay out and form a curve with a gradual starting of the motion and a gradual stopping. There is nothing worse for the life of a machine than to have it operated by cams cut by this "schedule" method. Another point to consider is that of taking advantage of all the time there is for any given movement. The period or periods of rest should be cut down to the last degree, so as to have the angularity of the rise as small as possible. Careful work at the drawing-

board will make a big difference with the satisfactory action of cams in these two respects. Still another bad practice, which has perhaps tended to throw the use of cams into disfavor, is that of making them in two or more parts, with the idea of having the working surfaces adjustable. After they have been wedged out, or shimmed up, or ground off a few times, a more proper name for them would be "bumpers" rather than "cams." Except in rare cases, there is no more use or excuse for adjustable cams than for adjustable gears, as there are other and better means of making adjustments when these are necessary. Cams are not very expensive as compared with gears, and they can be duplicated with greater accuracy than most machine parts. Especially is this the case if roughing and finishing mills are used in forming them, as the finishing mill will retain its cutting edge and size for a great number of cams, if it runs true with the spindle in the first place.

Cam Rolls and Roll Studs.

A few words might be said with relation to the design and construction of cam rolls and the studs for them, since the successful working of a cam depends to a considerable degree on this matter. The design of the roll and its stud should be such that the work it has to do, the speed at which it runs, and the bearing area on the stud, should be the factors determining its size, rather than the simple fact that there is a milling cutter in the tool-room of a certain diameter. It is equally important that the roll and stud should be ground all over after hardening. The end of the roll should also be cut back for $1/64$ th of an inch or so on the sides for some distance from the outside diameter, so as to avoid undue friction against the collar of the stud, or the part it is fast in. On account of the warping that takes place in hardening, rolls that are not ground inside and out have a habit of stopping frequently under load, until in time flat spots are worn on the face; then the working surface of the cam will begin to wear or rough up. Roll studs that are the slightest degree out of parallel to the working surface of the cam will also cause some trouble, but no amount of grinding will help this case. The same trouble occurs on barrel cams if the milling cutter is set above or below the center of the cam when cutting it. The roll will then bear at one end only at the most important time, when the throw takes place. A conical roll is the proper thing for this style of cam. There is a lot of end pressure to a roll of this type, however, which must be taken care of by thrust collars on the stud; or, better still, a ball race may be scored in the collar and the large end of the roll, so as to provide for a ball thrust bearing. This end pressure will reduce the side pressure on the stud to quite an extent, nevertheless, so the latter may be made slightly shorter or smaller in diameter than when a parallel roll is used.

Cutting Cams of Uniform Lead in the Miller.

When it comes to the cutting of cams, the shop man naturally turns to the milling machine. Many manufacturers of milling machines make attachments which may be used for cutting cams with formers.

None, however, is provided with anything except hand feed. Another, and the greatest, objection to them is that if there is much work to be done, one of the most expensive machines in the shop is tied up, and there are few shops that have a surplus of this brand of machine tools. For an occasional or an experimental job, however, there is nothing better than the milling machine. As has been before remarked, curves with easy starting and stopping movements cannot be cut without formers on it, or on any other machine for that matter; but cams which require a constant rise, such as the feed cams of some machines, may be cut on it without the use of formers. With barrel

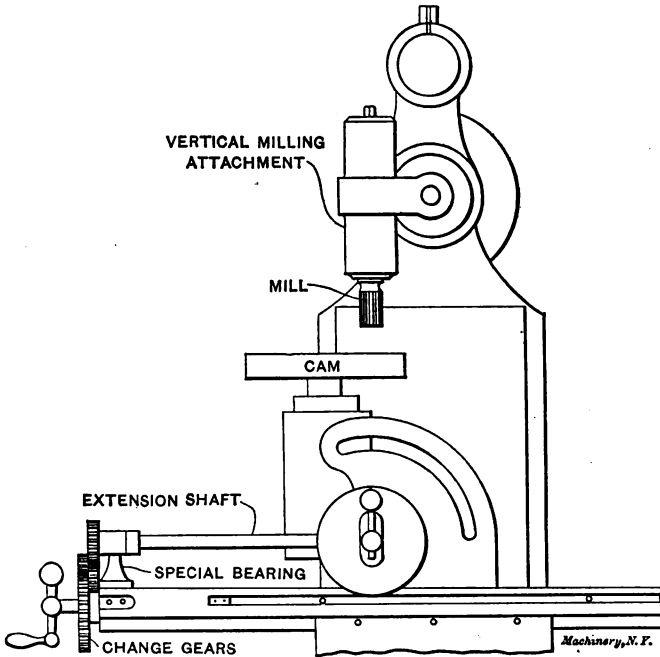

Fig. 32. Cutting a Face Cam of Uniform Rate of Throw.

cams the method is obvious, it only being necessary to gear the spiral head with the lead screw to get the required lead, and then cut a groove of this pitch in the body with an end mill of the same diameter as the roll.

For cutting plate cams for the same kind of motion, the arrangement shown in Fig. 32 may be used, if the machine happens to have a vertical spindle milling attachment and a spiral head. All that it is necessary to provide in addition is the extension shaft shown, and the special bearing or bracket for supporting it. These parts are used to bring the spiral head to the center of the table. The shaft is bored out at one end to fit the stud of the spiral head (called the worm gear stud in the tables); the other is turned and keyed to fit the change

gears. The cams may be held in the regular chuck, or on a face-plate fitted to the head. Small ones may be held on an arbor fitted to the spindle, with large collars to hold them firmly, clamped with a nut and washer, or by an expansion bushing in the case of large holes. If they have key-ways in them, and more than one or two are to be made, it will be well to fit a key in the arbor to help locate them. It is necessary to set the mill central with the spiral head to obtain correct results, as the spiral will vary if this is not done. Advantage may sometimes be taken of this when, with the regular change gears, there is no spiral of the exact pitch required, in which case the desired rise can be obtained by setting the head off center. This, however, will not give a uniform spiral, as the pitch will keep increasing as it leaves the center of the cam. As cam drawings are generally laid out or

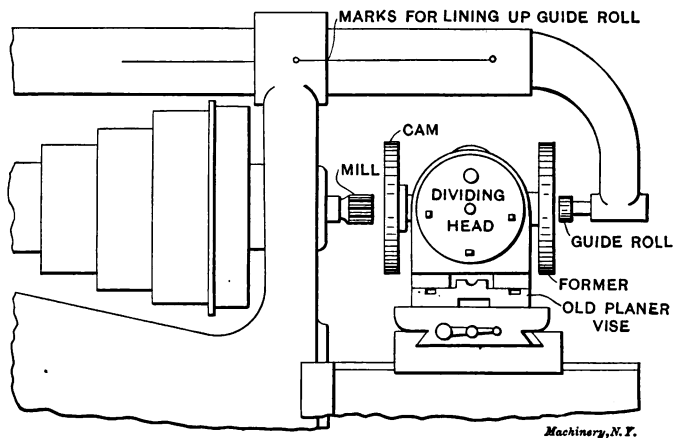

Fig. 33. Inexpensive Fixture for Milling Plate Cams to Match a Former.

divided in degrees, it will be found convenient to divide the cam blank by the same method, while held in the spiral head. To do this, we may revolve the index crank through two holes in the 18 circle or three holes in the 27 circle, as many times as are necessary, each of these divisions giving exactly one degree.

A Milling Machine Attachment for Cutting Cams with a Former.

An example of attachments rigged up to suit special requirements is shown in the cuts Figs. 33 and 34. To a shop with a rather limited equipment, an order came in for a lot of eight machines, which required seven cams each, most of which were of the plate type. As this class of work was new to the shop, there were no facilities for this part of the job; as usual, it was decided to do the work on the milling machine.

An old planer vise was scraped up and refitted so as to have the movable jaw a nice sliding fit—the screw having been removed, of course. To this jaw was fitted and bolted the spiral head of the miller, in such a way that its spindle could be placed either at right angles

or parallel to the cutter, as the case required for barrel or plate cams. An arbor was made, long enough to pass through the head, carrying the former on the back end and the cam blank on the front end. A nut threaded onto the back end held the former against the end of the spindle, so there was no danger of the arbors rattling loose, no matter how badly the work and tool chattered.

For plate cams, as shown in Fig. 33, the former was made the opposite hand to that of the cam required. The overhanging arm had a center line marked on it as shown, which was matched with one on the frame so as to locate the arbor support central with the spindle. In the place of the arbor supporting center there was fitted a stud with a roller of the same diameter as the cutter. The arm was held securely by the regular milling machine braces, which are not shown in the cut. The method of operation is obvious. The spiral head with

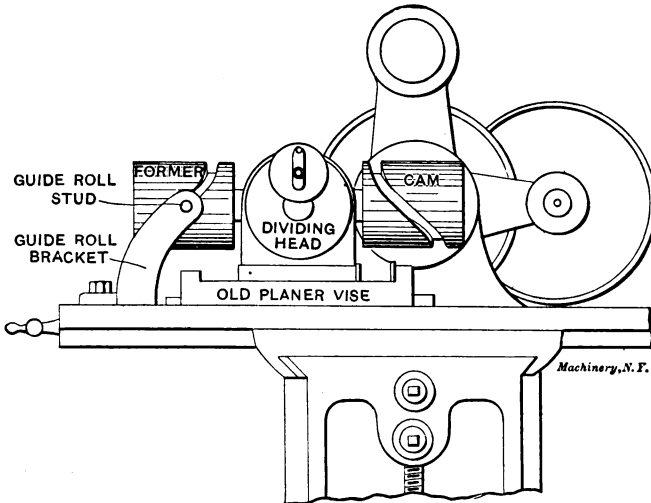

Fig. 34. Cutting a Cylindrical Cam with the Rig shown in Fig. 33.

its attached work and former was revolved, slowly, by hand. The action of the roll, held by the overhanging arm in the groove of the former, caused the head and work to slide back and forth on the ways of the planer vise, giving the proper movement between the work and the cutter to produce the desired contour of cam. The table was locked on the saddle.

For barrel cams, the attachment was rearranged as shown in Fig. 34. The former roller was held firmly in a bracket bolted to the table of the machine. As the roller is on the opposite side of the milling cutter, the former and work are set 180 degrees apart on the work arbor, otherwise they are alike. The head is relocated on the movable vise jaw to bring the axis of its spindle at right angles to the axis of the cutter, as shown. The reader will easily make out the other details from the cut.

Both of these rigs cut good cams, considering that the first cost of

the whole outfit was very little. As the formers were made accurately to drawing, the cams gave good satisfaction at fairly high speeds, but the device had the disadvantage of tying up a machine which had plenty of work waiting for it; besides, it was a tedious job to feed the index crank by hand all day long, especially when working on steel cams. For these reasons, when a duplicate order came in, a few weeks later, it was considered best to try the plan of cutting the plate cams on an old lathe, thus providing the advantage of an automatic feed, and relieving the miller of some of its work as well.

A Face Cam Cutting Attachment for the Lathe.

A lathe cam cutting attachment is shown in Fig. 35. While not new in principle, it differs somewhat from the other makeshifts described. For this rigging, the tool slide was removed from the machine and replaced with the bracket casting shown. This was fitted and gibbed to the tool-rest slide, and had its spindle bored and sides faced with a

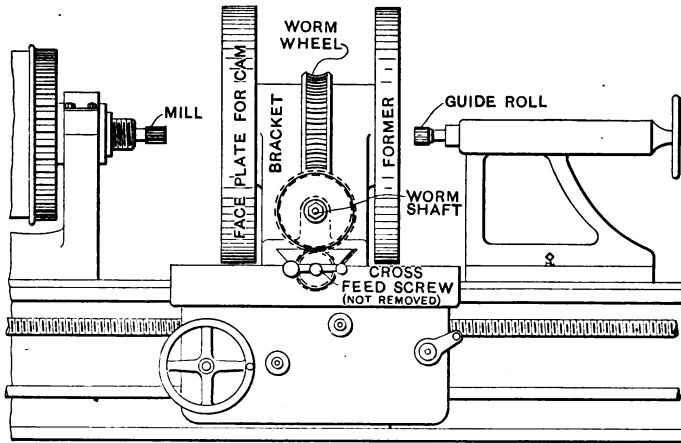

Fig. 35. Attachment with Power Feed for Cutting Face Cams.

boring bar on the lathe centers. To the bracket was then fitted the cam face-plate and spindle, cast in one piece and finished all over, with the back or small end threaded to fit the former. Keyed to this spindle was a worm-gear of cast iron. In this case the worm-gear had 82 teeth. Meshing with this gear was a worm having $9/16$ inch hole, and with a key having a sliding fit in the worm shaft. Bearings were provided for the worm shaft at front and back. The front support for the worm shaft was cast onto the bracket, and finished with it to fit the tool-rest slide, after which it was sawed off and fastened at the front of the carriage by the gib screw, as shown. This is the same practice as is commonly followed in making the clamp for the threading stop on the cross slide. To the outer end of the worm shaft was keyed a gear, meshing with another fitted and keyed to the front end of the cross feed screw next to the handle. The quill was cut off to make room for it. The cross feed nut was removed entirely, of course.

It will be seen that this arrangement, while having the general features of that shown in Fig. 33, provides the advantage of making use of a less costly and less over-worked machine, and allowed the use of a power feed as well, since the gearing provided for connection with the power cross feed in the apron. This gave a feed fine enough for small cams, but on large ones it was necessary to run the feed belt from the feed shaft cone to the hub of the large intermediate gear of the screw-cutting train, this being in mesh with the spindle gear. The lead screw was removed so as not to interfere with the belt. With regular changes this gave a wide range of feeds.

The cams and formers were held to their respective face-plates by bolts. All the formers were of the positive follower type having a groove for the guiding of the roller. No weight or other means is then required for the followers to hold them to their work.

CHAPTER IV.

SUGGESTIONS IN CAM MAKING.

In the present chapter are collected a number of suggestions for the laying out and making of cams, together with a discussion on the shape of cam rollers for cylinder cams. These suggestions have been contributed from time to time to the columns of *MACHINERY*. The

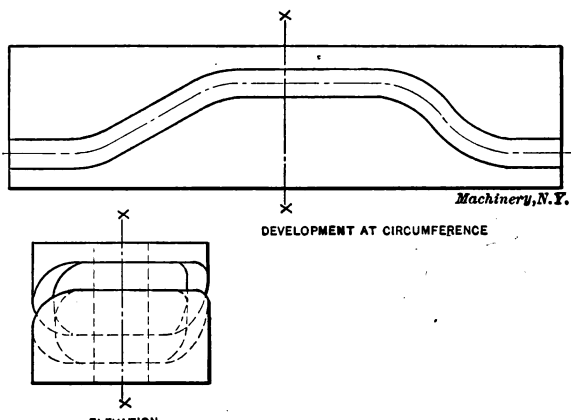

Fig. 36. Master Cam and its Development.

names of the persons who originally contributed the matter here selected, have been given in notes at the foot of the pages, together with the month and year when their contribution appeared.

Making Master Cams.

The method of originating cylindrical master cams, which is described in the following paragraphs, has been used successfully in a

shop where considerable of this work is done. A development of the cam at the surface of the cylinder is provided by the draftsman. If the cam is smaller than $2\frac{1}{2}$ or 3 inches diameter, or has unusually steep pitches in its make-up, the development had best be laid out for a diameter two or three times larger than that of the desired cam.

Suppose it is desired to make a master for the cam shown in Fig. 36. The first step is to make a template to match the development shown in the drawing. This template may be made of mild steel, of a thickness depending upon the diameter to which it is to be bent, as

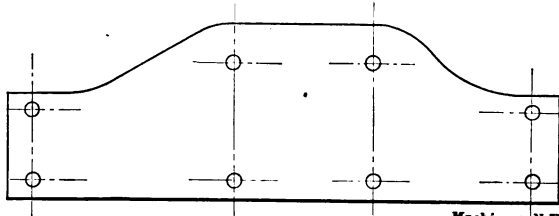

Fig. 37. Template for Making Master Cam in Fig. 36.

described later. It may be fitted to the drawing with cold chisel and file, or, if considerable accuracy is desired in the throw, the template may be held in the milling machine vise, and the straight surfaces finished to the graduations. This template, shown in Fig. 37, is made for one side of the cam groove only.

The next step is to turn up a piece of steel or cast iron, as shown at *B*, Fig. 38, to such a diameter that when the template *A* is wrapped around it, as shown, the ends will just barely meet. This diameter is about the thickness of the plate less than the diameter to which the

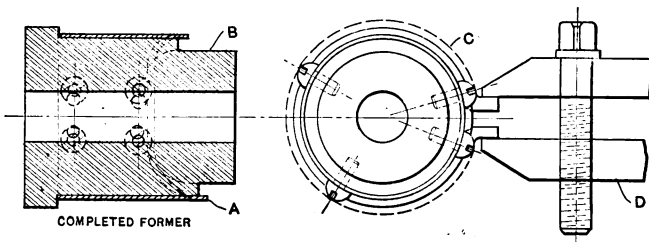

Fig. 38. Template Secured on Mandrel for Making Form.

development was laid out, but it had best be left a little larger and then fitted. The plate is now clasped around the body, with the back edge pushed close up against the shoulder to insure proper alignment of the working surface of the cam. If any difficulty is experienced in this wrapping process, a circular strap may be bent up with projecting ends as shown in dotted lines at *C*; with the aid of a clamp *D* the template may be stretched around smoothly. The template and the body may now be drilled and tapped for screws, as shown, and for dowels as well, if found necessary.

Write the contour of the cam onto the body *B*, remove the template,

place the body on an arbor between the index centers of the milling machine, and take away the stock for about $\frac{1}{8}$ inch deep, or so, $\frac{1}{16}$ inch back of the scribed line. This, as shown in Fig. 38, is for the purpose of providing a clearance underneath the working edge of the template. The template may now be placed in position on the body once more, and fastened there. The rig is now ready for use as a former for making a master cam.

Fig. 39 shows a milling machine arranged for cam cutting. *E* is a casting made to grip the finished face of the column, and carrying an adjustable block *F*. Cam roll *G* is pivoted on a post which is adjustable in and out in block *F*. Our former *H*, and master cam blank *I*, are mounted, as shown, on an arbor between the index centers. By working the index worm crank, and the longitudinal feed together, roll *G* may be made to follow the outline of former *H* in such a manner that the end mill will cut the desired groove in cam blank *I*. A slightly smaller mill may be used for a roughing cut, but it goes without saying that the roll and the finishing mill must be of about the

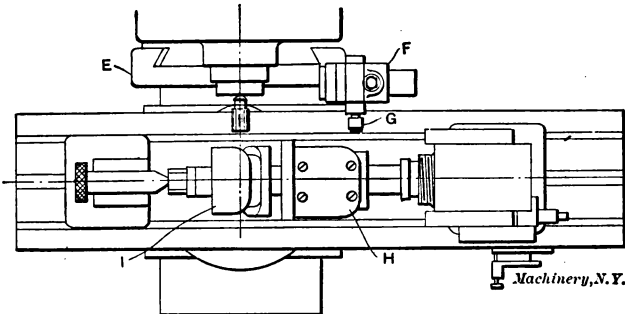

Fig. 39. Arrangement of Milling Machine when Using the Former.

same size if a true copy of the templet is desired. It will be found easier to follow the outline with the roll if the steeper curves are traced down rather than up.

A fairly good cam-cutting machine for making copies of the master cam *I* may be improvised by using the attachment *E*, *F*, *G* in a rack feed machine. It might also be feasible to connect the index worm with the telescopic feed shaft so as to give a power feed to the contrivance. To insure accurate cams, the arrangement for holding the tool must be made stiff enough to move the table without much spring, or the table must be weighed, so as to bring the pressure of the roll constantly against one face of the master cam.*

Simple Method for Cutting Cams Accurately.

Cams are generally laid out with dividers, machined and filed to the line. But for a cam that must advance a certain number of thousandths per revolution of spindle this divider method is not accurate. Cams are easily and accurately made in the following manner. For illustration, let us make the heart cam in Fig. 40. The throw of this

* R. E. Flanders, July, 1901.

cam is 1.1 inch. Now, by setting the index on the miller to cut 200 teeth and also dividing 1.1 inch by 100 we find that we have 0.011 inch to recede from the cam center for each cut across the cam. Placing the cam securely on an arbor, and the latter between the centers of the milling machine, and using a convex cutter, set the proper distance from the center of the arbor, we make the first cut across the cam. Then, by lowering the milling machine knee 0.011 inch and turning the index pin the proper number of holes on the index plate, we take the next cut and so on. Each cut should be

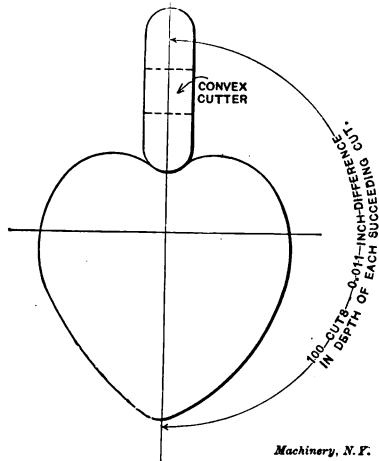

Fig. 40. Method of Cutting Cams.

marked on paper so that there will be no mistake as to number of cuts taken; when 100 cuts have been made the knee must be raised in order to complete the opposite side of the cam.*

Device for Laying Out the Cams of a Cam-Actuated Press.

The cams which actuate the cutting or drawing slide of a double acting cam-press are different from other cams, inasmuch as each one actuates two rollers which are a certain fixed distance apart from each other. In order to avoid back-lash or springing of the connecting-rods, a fault which is to be found in most cam presses, it is evident that the rollers must both touch the face of the cam at all times. In Fig. 42 is shown the ordinary method of laying out such cams; this cut also shows the fact that this ordinary method does not accomplish the end desired. We see that in this cam both curves which give to the slide its up and down motion are constructed with the same radii, which clearly must give a curve that is faulty at certain points. The one main feature that our cam must possess can be expressed as follows: Two rollers of equal diameters, which are a certain fixed distance (*A* in Fig. 42) apart, on a line passing through center of cam, must always tangent the cam while the cam makes its revolution.

* F. E. Shailor, March, 1907.

Turning to Fig. 42, we see that the curve which spans angle C and the dotted curve which spans angle D accomplish this object. A little reflection will convince that such a curve cannot be constructed absolutely correct by giving the radii for both the up stroke and down stroke curve, owing to the fact that the shape of one is entirely dependent on the shape of the other.

We can, however, give the radii for one curve and construct the other curve from it by aid of the following device. It is assumed that in most cases it will be economical to cut a master-cam, and use this for cutting the others. However, where only a few cams are to be cut, it will be well to construct one with the aid of our device, and

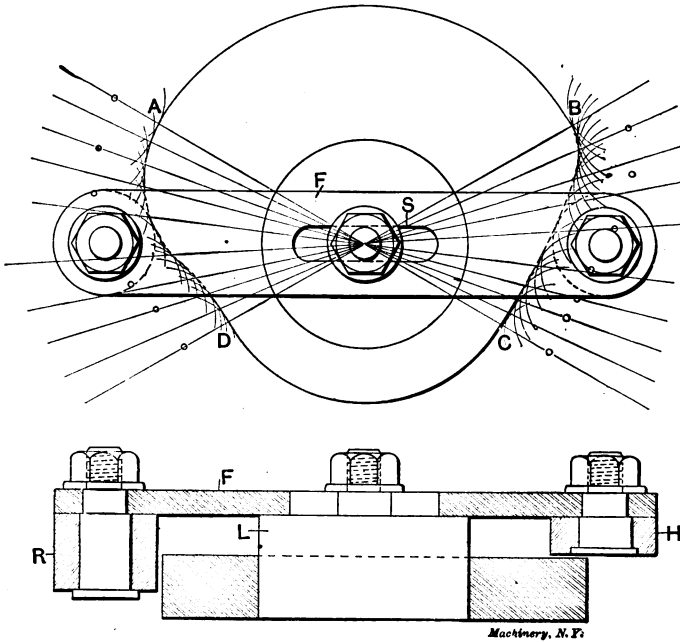

Fig. 41. Device for Laying Out Cams for Cam-Actuated Press Correctly.

use this one as a templet for the others. Fig. 41 shows the device mentioned. First, cut the two arcs, AB and DC , which of course are perfect circular arcs of given radii, and also cut the curve AD from given radii. Then place center plug L into center hole of cam and fasten bar F onto L . Bar F has two rollers, R and H , fastened in such a way that their center distance is equal to the center distance of the cam rollers in the cam press in which the cams are to be used. The rollers R and H have the same diameter as the cam rollers in the press. We now keep the roller R against the cam along the curve AD and follow this curve along its entire length. Center plug L will always keep the line connecting R and H in the center of the cam, and slot S enables us to follow the curvature of AD . By scratching

the outline of roller *H* on the cam blank at very short distances apart, we will have a full outline on the cam blank, which must indicate the absolute curvature of *BC*. This curvature must possess all the qualifications set forth above as absolutely indispensable for a correct cam press cam. A cam or set of cams laid out in this manner will

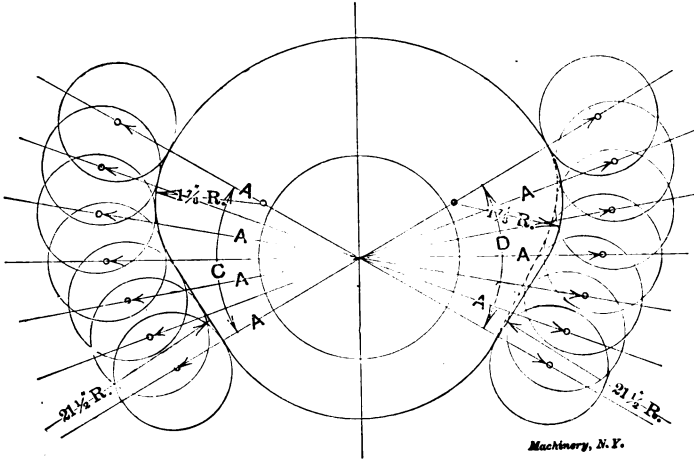

Fig. 42. Ordinary Method of Laying Out Cams.

silence one of the principal objections usually raised against a cam actuated press, viz., back lash or springing of the cam roller connecting-rods.*

Shape of Rolls for Cylinder Cams.

The grooves and rolls for cylindrical cams are made in various ways, more or less suitable for the work to be done. Fig. 43 shows a

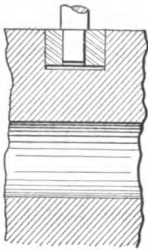

Fig. 43.



Fig. 44.

Different Forms of Cam Rolls.



Fig. 45.

straight roll and groove, Fig. 44 a roll with a rounded surface in a straight sided groove, and Fig. 45 a beveled roll and groove. In Fig. 43 the action of the roll is faulty, because of the varying surface speed of the cam at the top and bottom of the groove, due to its varying radial distance from the center line. This causes excessive

* E. E. Eisenwinter, July, 1907.

wear and friction, especially in a quick running cam with steep pitches. For such cases, if the duty is light, the arrangement shown in Fig. 44 is better, as the roll has but a very small bearing surface, and is thus unaffected by a varying radial distance. For heavy work, however, the small bearing area is quickly worn down, and the roll presses a groove into the side of the cam as well, destroying the accuracy of the movement, and allowing a great amount of backlash.

In Fig. 45 the conical shape is given to the roll with the idea of giving it a true rolling action in the groove. In most cases where this shape is used, however, the lines of the sides of the roll appear to converge to the center line of the cam, as shown in the figure. If the groove were a plain circumferential one, it would give a perfect action, like that of the pitch cones of two bevel gears rolling on each other. If the motion were in a line with the axis of the cam, without any circular movement, conditions would be perfect in Fig. 43. It is evident that in intermediate conditions, the groove must be given a

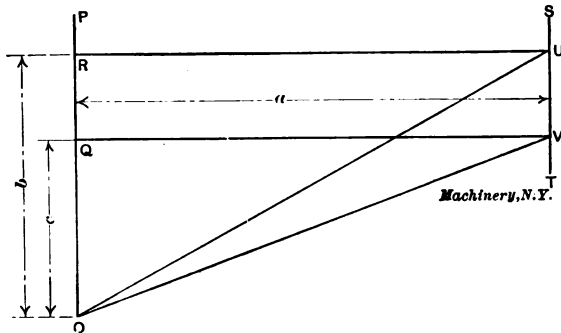

Fig. 46. Diagram Showing Method of Finding Shape of Cam Rolls.

shape intermediate between the two. In many cams of this variety the heavy duty comes on a section of the cam which is of nearly even pitch and of considerable length. In such a case it is best to proportion the shape of the roll to work correctly during the important part of the cycle, letting it go as it will at other times.

In Fig. 46, b is the circumferential distance on the surface of the cam, which includes the movement we desire to fit the roll to. The throw of the cam for this circumferential movement is a . Line OU will then be a development of the movement of the cam roll during the given part of the cycle, and c is the movement corresponding to b , but on a circle whose diameter is that of the cam at the bottom of the groove. With the same throw a as before, the line OV will be a development of the cam at the bottom of the groove. OU then is the length of the helix traveled by the top of the roll, while OV is the amount of travel at the bottom of the groove. If then the top width and the bottom width of the groove be made proportional to OU and OV , the shape will be suitable to give the result we are seeking.*

* R. E. Flanders, December, 1904.

