

FULL AUTO

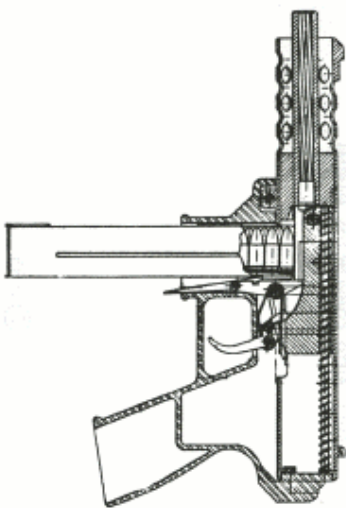

**KG-99, KG-99 MINI
TEC-9, TEC-9 MINI**

**FULL AUTO
CONVERSION MANUAL**

**FULL AUTO
KG-99, KG-99 MINI, TEC-9, TEC-9 MINI
FULL AUTO CONVERSION MANUAL**

WARNING !

The legal construction and possession of a fully automatic weapon is controlled by the Bureau of Alcohol, Tobacco, and Firearms division of the U.S. Treasury Department.

Proper application to the B.A.T.F., authorization, and permission must be secured before constructing this or any other similar device. Local and state laws vary and may restrict ownership of this or similar type weapons.

Severe penalties are authorized for violators of these laws. Minuteman Publications offers this information for academic study of firearms design and disclaims any responsibility or liability for the improper or illegal use of this or other similar devices.

Table Of Contents

CONTENTS	PAGE
Introduction	5
Chapter 1 Background Information	7
Chapter 2 Operation & Disassembly	17
Chapter 3 Conversion Procedure	31
Chapter 4 Assembly & Testing	41

Introduction

The purpose of this manual is to present the necessary engineering data, manufacturing procedures, and machinist drawings which are used for conversion of the "Kg-99" family of semi-automatic pistols into ultra-compact, fully automatic submachineguns which fire from an open bolt.

The information provided in this manual applies to conversion of the INTERDYNAMIC KG-99, KG-99 MINI, INTRATEC TEC-9, and TEC-9 MINI. The forerunner of this series of weapons is the KG-9, a semi-automatic pistol which fires from the open bolt. Because of the limited number of KG-9's produced, full auto conversion of these will not be addressed in this manual.

Under provisions of the GUN CONTROL ACT of 1968, individuals owning semi-automatic weapons may apply to the BUREAU OF ALCOHOL, TOBACCO, AND FIREARMS division of the U.S. Treasury Department on ATF FORM 1 for authority to convert their weapon to fire fully automatic. Those persons not able to do the actual conversion may choose to purchase a converted weapon from a Class II firearms mfg. or Class III "machinegun" dealer. These would be handled on ATF Form 4. The transfer tax required for ownership of a machinegun is \$200.00 per weapon registered.

This is a one time fee paid to the Treasury Department allowing individual ownership. However, state and or local laws restrict private ownership of machineguns in various parts of the country, requiring investigation by prospective owners prior to acquiring or converting a gun to fire fully automatic.

The full auto conversion procedure in this manual has been fully tested with excellent results. The process requires the skills of an experienced machinist, a requirement often criticized by persons who simply want to be able to "grind this part or that sear engagement" to have a "machinegun". The key factor in this design is reliability, a principal consideration for those persons whose lives may depend on the function of their weapons. Much engineering effort went into the initial design of the semi-automatic series of weapons, and similarly extensive engineering was required in producing a practical and functional full auto design based on the semi-auto weapons.

The end result of these design efforts is a family of highly functional, rugged, and reliable submachineguns of moderate cost. The weapons featured in this manual are lightweight, compact, simple in design and maintenance, inexpensive, and high in performance. They represent many years of submachinegun design in which effective and battle proven concepts have been combined using modern manufacturing techniques.

1

Background Information

Before getting into the specific details of the weapons involved, it is of interest to note the development of this family of weapons. The Swedish firm Interdynamic AB is the parent company who designed the Kg-9 pistol, which was subsequently manufactured by INTERDYNAMICS, INC. of Miami, Florida, and distributed by F.I.E. (Federal Import and Export Co.)

The Kg-9 and the other versions to follow it are all futuristic looking, featuring computer assisted designs utilizing the latest manufacturing technology. The basic mechanisms of the weapons produced are not really anything new or revolutionary. One must realize that most new firearms produced use several individual component designs decades old. Time, as well as extended periods of field use in conflicts around the world, have proven several basic mechanical designs which are then "borrowed" and incorporated in later "newly designed" weapons.

It is not surprising that the Swedes originated the Kg-9, owing to the fact that they have been quite successful in firearms design and manufacture through modern history. The famous Karl Gustaf "K" SMG greatly influenced the design of the Kg-9. By comparing the model "K" to

the Kg-9, it is easy to see various elements of the "K" that were scaled down, streamlined, and made simpler to manufacture. The entire Kg/TEC series as well as the model "K" are considered second generation weapons. It is interesting to see development in this area in light of the success of third generation weapons such as the MAC and UZI weapon families. Third generation basically indicates wrap-around bolts and magazine housings contained in the grip assembly providing "hand meets hand" loading.

The "Kg" used in designating the INTERDYNAMIC model reportedly is taken from "Karl Gustaf", the "g" perhaps designating the caliber. Other influential weaponry used in designing the Kg-9 were the German MP-38/40, Maiter MP's, and the US M3/M3-A1 SMG's. The original Swedish produced versions of the Kg-9 were reported to have been "machine-pistols", designed for special purposes requiring maximum firepower in a small package.

The construction of the Kg/TEC family incorporates the use of a synthetic plastic material which comprises the lower receiver. This part is an integral unit which houses the entire trigger/sear mechanism as well as the magazine latch mechanism. The lower receiver is very lightweight, yet strong due to the use of Dupont "high impact" phenolic resins. The unit is very nicely injection molded, being reinforced at stress points. The use of high impact plastics in firearms production is becoming more commonplace each year. Using materials of this type is often snubbed by "purists", but allows the expedient production of parts which would be difficult and expensive to machine in a conventional manner. The bottom line here is that

the overall cost per unit is greatly reduced, a definite plus in this age of expensive weaponry, (UZI, HK-94, STERLING).

The tubular upper receiver features ventilation holes in the barrel jacket to disperse heat build up, and houses the barrel and bolt assembly. This unit attaches to the lower receiver by keying the upper receiver onto a rear mounted disc attached to the lower receiver, and by aligning and assembling the upper to lower receivers at the front of the plastic housing using a single assembly pin.

The Kg-9 uses an open bolt mechanism incorporating the use of a fixed firing pin. This design was in production as a "semi-auto" pistol, but after producing only approximately 2500 of these units, production was forced to cease due to a re-classification of the Kg-9 as a "machinegun" due to the ease and frequency that these models were being illegally modified to fire fully automatic. The serial numbers of the Kg-9's were merely stamped into the plastic lower receiver, which could be easily altered and removed. Current production models use a steel serial number plate molded into the receiver.

After the Kg-9 was declared a "machinegun" by a BATF ruling, all Kg-9's produced before January 19, 1982 had to be registered as Title 2 firearms, the same as any submachinegun although they were semi-auto. This led to the design and introduction of the Kg-99, basically the same as the Kg-9, except that the weapon fires from a closed bolt. The bolt incorporates a floating firing pin which is carried by the

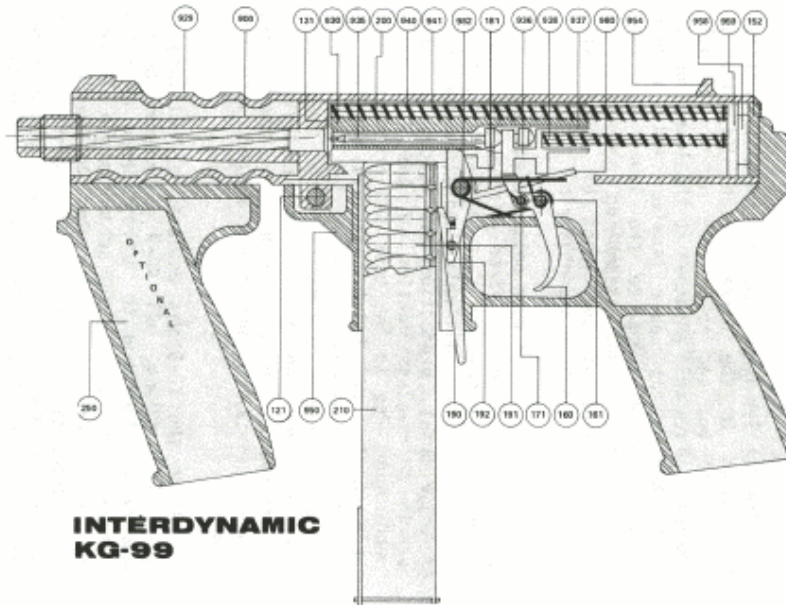

900	Barrel	152	Rear cover
121	Assembly catch	958	Buffer
123*	Snap ball	959	Buffer plate
124*	Snap spring	156*	Screw
954	Rear sight	151*	Assembly pin
135*	Sling catches	160	Trigger
920*	Receiver tube	161	Trigger axis
929	Upper receiver sub-assembly	162*	Trigger spring
930	Bolt	170*	Disconnecter
131	Extractor	171	Disconnecter axis
132*	Extractor screw	172*	Disconnecter spring
933*	Operating handle	980	Sear
934*	Operating handle spring	181	Sear axis
935	Firing pin	185*	E-Ring
936	Striker	183*	Sear retainer
937	Striker spring	982	Sear spring
938	Striker spring guide rod	190	Magazine catch
940	Recoil spring	191	Magazine catch axis
941	Recoil spring guide rod	192	Magazine catch spring
144*	E-Ring	200*	Ejector
950	Frame (lower receiver)	210	Magazine assembly
928*	Bolt assembly - complete	250	Assault grip

Parts list and cross section of the KG-99 semi-auto pistol.

(NOTE - The * designates parts either not identified by number or not shown in this view.)

striker assembly. The striker is spring loaded by tension exerted from the striker spring.

Each pull of the trigger allows the striker assembly to slam forward, the trigger movement having forced the disconnect downward, a machined notch of the same engaging and pulling the sear down simultaneously which disengages the striker, providing force to be transmitted to the cartridge primer through the firing pin. The detailed description of this sequence in both the semi-auto and converted full auto weapon will follow in a later chapter.

The KG-99 was introduced as a moderately priced weapon, the current retail price running around \$250.00. This low price combined with the good availability has made it a very popular item with shooters ranging from plinkers, survivalists, and home owners as a high volume self defense firearm. The relatively small size of the gun made it handy for executive protection, being small enough to carry in a briefcase without the weight factor common to the MAC-10. The only thing it lacked was a full auto capability which Interdynamics, Inc. (USA) later addressed in a version known as the MP-9. At this writing the fate of the MP-9 is unknown. It was eagerly anticipated but early models were plagued with quality problems in the bolt area, specifically the heat treatment of the sear engagement area of the bolt.

This area was identified and presumably corrected, but the promotion of the MP-9 SMG has been low key. The MP-9 was produced as a selective fire SMG, the selector located on the right side forward of the trigger. The

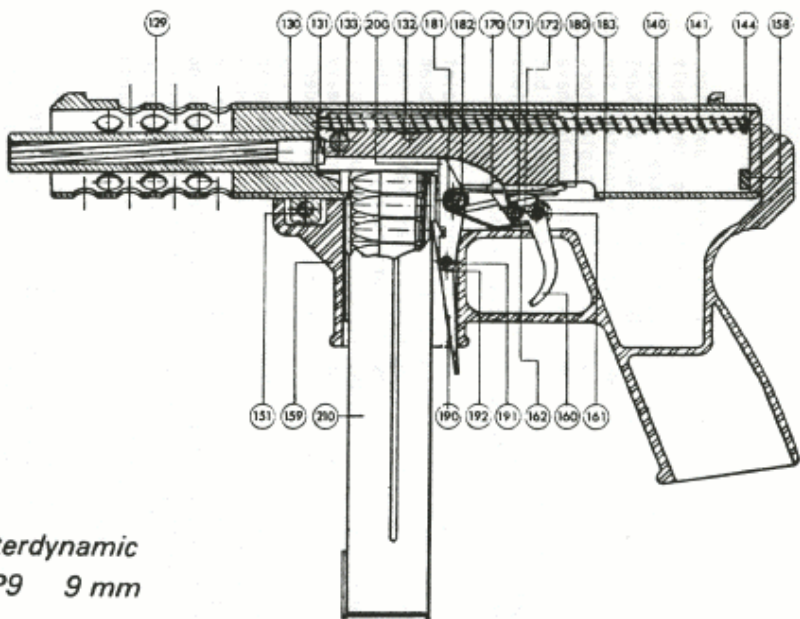

*Interdynamic
MP9 9 mm*

*Cross-sectional diagram of the commercial
INTERDYNAMIC MP-9 9mm SMG.*

selector did not provide a "safe" position, this being accomplished by rotating the bolt handle upward into a locking notch in the receiver reminiscent of the STEN MkII, MP-38/40, or Karl Gustaf "K". The MP-9 also incorporated the addition of a simple wire form retractable stock similar to the US M3/M3A1. This would have been a worthy addition to the KG-99 pistol but unfortunately would have violated BATF regulations regarding shoulder stocks attached to hand guns.

Probably the most noteworthy complaint against the production model KG-99's has been the long, rough trigger pull, as well as the inability of shooters to comfortably hold the weapon with one or two hands. The weapon, fully loaded, weighs 67 ounces making it front-heavy when firing one handed. When shooting two handed, there is really no proper (conventional) way to place the left hand. An optional foregrip is made that attaches to the bottom of the ventilated barrel jacket, as seen in the photos in this manual. This solves the problem of holding the weapon, becoming very important after conversion to fully automatic. The grip is positive and controllability as well as user confidence are improved greatly.

Due in part to the success of the KG-99 and the complaints regarding handling difficulties, a third version evolved, known as the KG-99 MINI. The MINI shares the same lower receiver as the KG-99, the only difference being that the barrel and upper receiver are shortened. The barrel of the MINI is 3.0" long as opposed to the 5.0" barrel of the KG-99. The ventilated barrel jacket is eliminated on the MINI, the upper receiver ending just forward of the barrel



INTERDYNAMIC KG-99 semi-auto pistol with 36 round magazine and optional front grip.



INTRATEC TEC-9 MINI semi-auto pistol with 20 round magazine.

bushing. This compact version comes with a 20 round magazine as opposed to the standard 36 round magazine of the KG-99. A different recoil spring is used in the MINI due to the lower pressure generated in the 3.0" barrel. Both the KG-99 and KG-99 MINI come standard with threaded barrels for attachment of recoil compensators, flash suppressors, or sound suppressors (silencers). The MINI is the preferred choice for silencing because of its lower projectile velocity. The 5.0" barrel produces a projectile velocity of 1200-1400 fps, exceeding the speed of sound and causing a "crack" as the bullet breaks the sound barrier. The retail price of the MINI runs about \$40.00 less than the KG-99.

Later, both of these models were further popularized by the introduction of stainless steel construction, and important development in firearms construction and use, especially marine use in a salt water environment.

At some time during 1985 or perhaps late 1984, the name of the company "Interdynamics, Inc." was changed to "INTRATEC". The reason is immaterial as no changes were noted in the construction of their guns. The model designations did change, the KG-99 becoming the "TEC-9", and the KG-99 MINI becoming the "TEC-9 MINI". These are the current production models, the stainless versions also being available.

2

Operation & Disassembly

The KG-99, KG-99 MINI, TEC-9, and TEC-9 MINI are all semi-automatic pistols which operate by elementary blowback, firing from the closed bolt. The full auto conversion of these weapons will change the mode of operation to open bolt functioning, providing full automatic functioning with operator control of the length of burst. This full auto conversion is not selective, however, excellent results can be achieved with minimal training. This type mechanism (being non-selective) duplicates functioning of many submachineguns in production and use worldwide.

OPERATION - SEMI AUTO PISTOL

A loaded magazine is inserted with the bolt in the forward (closed) position. The firer pulls the operating handle fully rearward, then sharply releases it, allowing it to move forward under the pressure exerted by the recoil spring. This allows the bolt to strip and chamber the top cartridge from the magazine into the barrel chamber. The act of retracting the operating (bolt) handle previously described causes the striker to engage the sear, the firing pin being held in a "cocked" position.

With the bolt forward the firer may place the weapon on "safe" by pushing the bolt handle

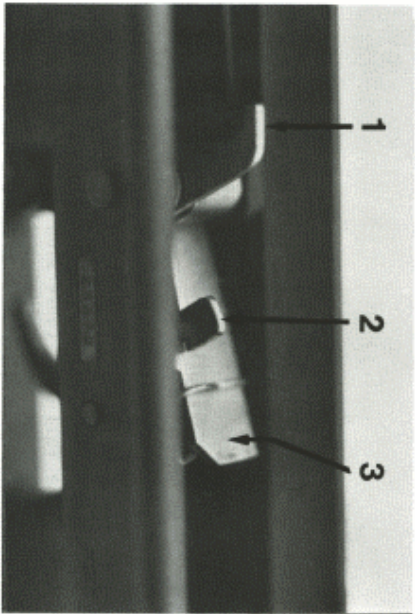

View of KG-99 lower receiver detailing:

1. Ejector
2. Disconnecter
3. Sear



Top view of lower receiver showing same components as identified in preceding photo.

in towards the receiver. This blocks the firing pin from moving forward. To fire the weapon the bolt handle must be pulled out to the "fire" position. At this time the trigger is pressed, the movement of which forces the disconnecter downward pulling the sear down simultaneously. As the sear disengages the base of the striker, the spring tension exerted by the striker spring forces the striker and firing pin forward, identifying the primer and detonating the cartridge. The forward movement of the striker also pivots the disconnecter forward out of engagement with the sear.

The rapidly expanding gases generated in the cartridge case propel the projectile into the rifled lands of the barrel. The gases push rearward against the now empty case and bolt, the heavy mass opening only $1/16$ " at the time the bullet leaves the barrel. The bolt continues back, extracting and ejecting the empty case. The striker assembly moves rearward with the bolt, passing over the sear nose. The recoil spring is supported by a guide rod, and the tension exerted overcomes the mass of the bolt, causing it to stop and reciprocate forward, stripping and chambering another live cartridge. The trigger must be released so that the notch in the rear of the disconnecter may rise and engage the sear. By pressing the trigger again, the firing sequence will then be repeated. At any time the weapon may be put on "safe" by pushing the bolt handle "in" after the bolt is in the "closed" position.

OPERATION - FULL AUTO SMG

The weapon is loaded in the same manner as the semi-auto versions. To ready the weapon for firing, retract the bolt handle fully rearward. The bolt features a fixed firing pin and a sear engagement step. By releasing the bolt, the recoil spring will cause the bolt to move forward slightly, its movement stopped as the sear intercepts the bolt (step on bottom of bolt). The firer then presses the trigger, the disconnecter pulling the sear nose down out of engagement with the bolt, allowing the bolt to move forward sharply, the raised feed tip of the bolt face catching the base of the top cartridge in the magazine.

The inertia of the bolt movement strips the round out of the magazine and guides it up the feed ramp and into the chamber. As the bolt nears its maximum forward travel, the cartridge case will locate securely in the chamber, the extractor claw will spring over the rim of the case and the firing pin machined into the bolt face will indent and ignite the primer. The resultant ignition propels the bullet through the barrel, with the bolt mass remaining closed until the bullet nears the muzzle. The inertia of the gases generated will force the bolt rearward, and as the bolt nears maximum rearward travel, the recoil spring arrests bolt movement and forces it forward again. At this point the firer may continue to hold the trigger down, the disconnecter being engaged with the sear, which cannot rise to intercept the bolt until the trigger is released. The firing sequence will repeat as long as the trigger is depressed, or until all cartridges are fired.



KG-98 open bolt SMG being readied to fire. Step one is to push bolt handle into the safe position.



Insert a loaded magazine upward into magazine housing. Push firmly until the magazine latch engages locking block on magazine.



When ready to fire the weapon, pull the bolt handle out of the "safe" position. Then retract the handle and bolt assembly until it engages the sear.



Close up view of the ejection port showing the bolt in the "cocked" position with a loaded magazine in place. Note top cartridge in magazine.

22



To unload the SMG, the bolt will be in the "cocked" position and the firer simply presses the magazine latch towards the magazine and pulls downward on magazine.

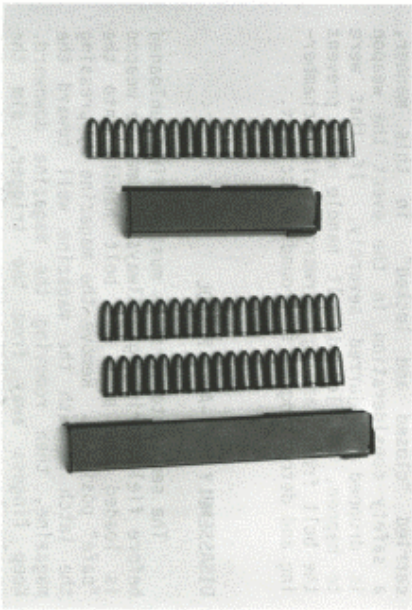

Comparative view of the 20 round magazine (left), and 36 round magazine (right).

23

As with the semi-auto versions, the bolt handle may be pressed in to lock the bolt in the "closed" position. It is recommended that the weapon be carried with the bolt "closed" on an empty chamber, with the safety (bolt handle) "on". In the full automatic version the safety mechanism is the large diameter step on the bolt handle which, when the handle is depressed fits into an enlarged area of the bolt handle slot which is wider than the rest of the slot. The bolt cannot reciprocate rearward because the slot is narrower than the handle shank except for the front portion. This also applies to the semi-auto safety, a two part safety which blocks the firing pin as well as blocking rearward bolt movement.

When ready to fire, pull the handle out then retract the bolt to the open (cocked) position. It is common for open bolt SMG's to be carried "closed and locked" in this manner, a safety consideration in the event the weapon is dropped or jarred severely. If that were to happen, the locked bolt handle will prevent the bolt from slamming rearward possibly chambering and detonating a live round by accident.

DISASSEMBLY SEMI-AUTO PISTOL

The semi-auto versions must be first unloaded before field stripping. Always assume the weapon is loaded and push the bolt handle into the "safe" position. Remove the magazine by pressing the latch beneath the magazine well toward the magazine, then removing the magazine downward. Keep fingers away from the trigger, aim the muzzle in a safe direction, pull out on the

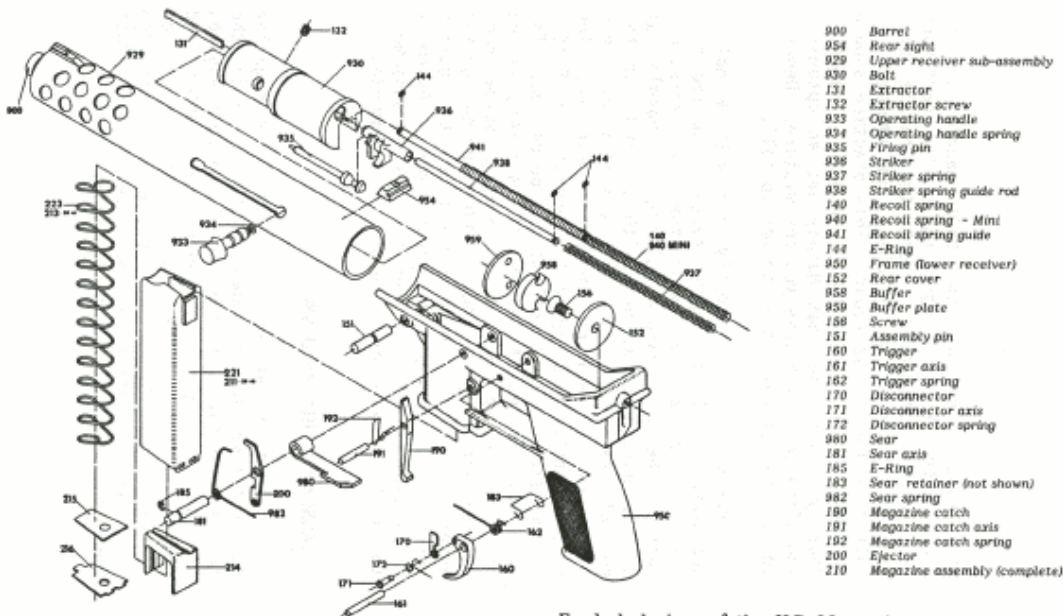

Exploded view of the KG-99 semi-automatic pistol.

bolt handle, retract the bolt handle to the rear, extracting and ejecting a live cartridge if one was chambered. Work the handle back and forth then visually check the chamber and bolt face for a live round. This practice should be employed on all automatic weapons. Remember "Murphy's Law" and that Murphy was an optimist! Too often he only allows you one mistake. Depress the trigger allowing the striker to fall.

Press out the assembly pin with a mallet and punch. Pull the upper receiver up and forward, out of assembly with the lower receiver. Retract the bolt handle pulling the handle out of the bolt when aligned with the hole at the end of the slot. The bolt assembly will now slide out the rear of the upper receiver. The bolt assembly is stripped by removing the E-ring on the end of the recoil spring guide rod. The bolt will slide off leaving the striker, firing pin, recoil spring, recoil spring guide rod, striker spring guide rod, striker spring, buffer assembly, and two more E-rings at the buffer end of the respective guide rods. Assemble by reversing this procedure. No disassembly to the lower receiver is needed or recommended.

DISASSEMBLY FULL AUTO SMG

Unload the weapon by removing the magazine as described in the above section. Pull the bolt handle fully rearward until the bolt engages the sear. Visually inspect the chamber and bolt face for a live round. (The purpose of checking the bolt face is to see if a cartridge has been positioned in the recessed bolt face and being held in place by the extractor).

After assuring an unloaded condition, allow the bolt to close on an empty chamber by aiming in a safe direction and pressing the trigger. Press out the assembly pin securing the two receiver components, lift the upper receiver and pull it forward off of the disc at the rear of the lower receiver. At this time pull the bolt handle fully rearward to the enlarged hole in the receiver slot and retract the bolt handle out of the receiver. The bolt assembly will slide out the rear of the receiver at this time. Only the recoil spring, recoil spring guide rod, and recoil buffer assembly will be attached to the bolt. Removal of the front E-ring from the recoil spring guide rod will allow removal of the bolt body. Reverse the procedure to reassemble.



Before disassembly, unload the weapon and place the bolt in the closed position.



Use a suitable punch and press the assembly pin out of the lower receiver.

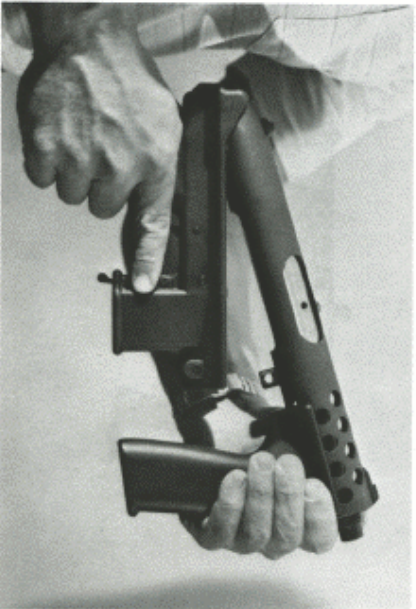

The upper receiver may now be tilted upward at front, and pulled forward out of the lower receiver.

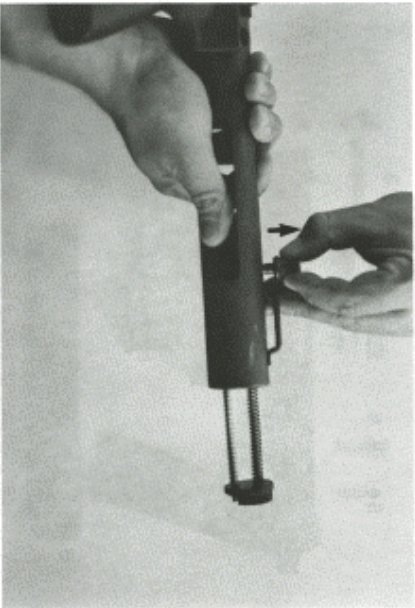

Slide the bolt assembly rearward until the bolt handle can be pulled out of the bolt and through the enlarged hole in the receiver slot.



Slide the bolt assembly rearward out of the upper receiver body.



The KG-99 SMG field-stripped into its major components.

1. Upper receiver assembly with optional vertical foregrip.
2. Lower receiver assembly
3. Full-auto bolt assembly
4. Bolt handle
5. Assembly pin

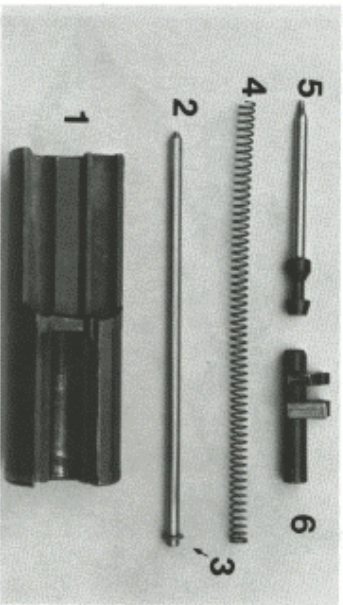

Semi-auto parts removed for the full auto conversion:

1. Bolt
2. Striker Spring Guide
3. E-Ring
4. Striker Spring
5. Firing Pin
6. Striker

30

3

Conversion Procedure

The conversion procedure outlined in this chapter falls under federal regulations regarding machineguns, and the completed bolt necessary to facilitate full auto functioning in any of the weapons previously mentioned is considered a machinegun itself by definition, irregardless of the presence of a firearm. The conversion described here requires the manufacture and installation of a new bolt. This bolt is the only component required to produce full auto fire, henceforth the bolt becomes the registered element comprising a "machinegun". DO NOT BEGIN CONSTRUCTION OF THE BOLT UNTIL ATF APPROVAL IS RECEIVED. FAILURE TO DO SO MAY SUBJECT THE BUILDER TO A FINE OF UP TO \$10,000.00 AND/OR INCARCERATION OF UP TO TEN YEARS.

As described in the previous chapter, the fully automatic KG-99, KG-99 MINI, TEC-9, and TEC-9 MINI all operate from the open bolt. The original semi-auto bolt, striker, striker spring, striker spring guide, E-ring, and firing pin are not used and may be saved for spare components if the weapon were to be later converted to semi-auto, (an example being to move to another state in which machineguns are not permitted). The extractor and extractor screw are removed and used with the new bolt. It is advisable to simply order a replacement extractor and

31

screw in the event the original ever becomes damaged.

The SMG open bolt is detailed in the accompanying drawings and photos. The bolt retains most of the same profiles and dimensions of the original semi-auto bolt. All dimensions are provided to fabricate a new bolt from the respective drawings, but it will be helpful to the machinist to compare the old bolt noting the similarities to the drawings for reference during construction. The areas of difference between the two are described as follows:

1. Elimination of the complex rear cavity housing the striker assembly and firing pin. The open bolt does away with all of these components, allowing the rear bottom section of the bolt to remain "solid". Also, the firing pin hole through the center of the bolt is deleted. Additionally, the striker spring guide rod hole through the bolt is deleted. The photos clearly show bottom views of both semi and full auto bolts.
2. Utilization of a fixed firing pin. As noted in #1 above, the floating firing pin has been deleted. A fixed firing pin is machined into the bolt face to the prescribed dimensions. Also of critical importance in assuring proper feed in open bolt SMG's is the raised "feed lip" on the bolt face. This is a ridge the same height as the major bolt face, and is the part of the bolt which contacts the base of the cartridges as they are stripped from the magazine. The importance of this "ridge" is that it keeps the base of the cartridge away from the protruding

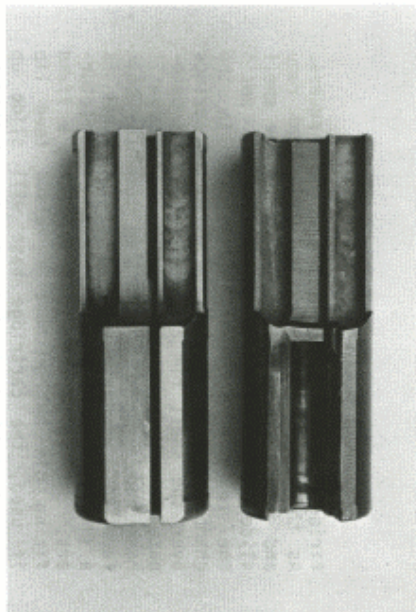

Comparative view of the bottom of the semi-auto pistol bolt (top), and SMG open bolt (lower). Note absence of cavity in rear of SMG bolt. Also note rear engagement "step" on SMG bolt.

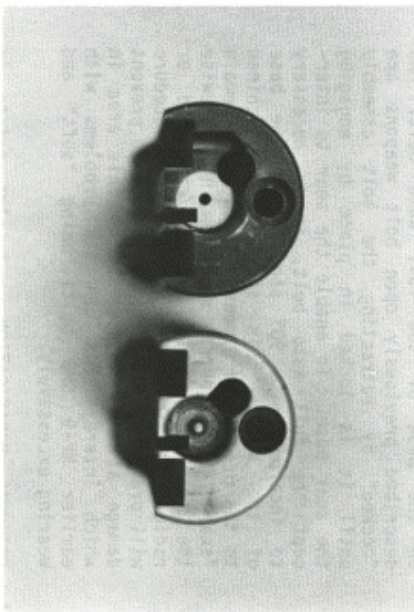

Front views of semi-auto bolt (left), and SMG bolt (right). Note fixed firing pin and raised feed lip on SMG bolt.

firing pin located in the bolt face recess. As the cartridge is fed up the barrel ramp and into the chamber, the base of the shell slides smoothly over the feed lip until the round is properly positioned in the chamber, at which time the extractor springs over the shell rim and the firing pin detones the primer. The semi-auto bolts will have had a relief cut milled into the bolt face to the depth of the recess. This is a common practice for all weapon manufacturers. If, for instance, a bolt with a fixed firing pin but without a raised feed lip is used, the cartridge base will slide up the recessed bolt face during chambering until the rim of the case contacts and jams against the protruding firing pin.

3. Establishment of a "sear engagement step" on the base of the full auto bolt. As described previously open bolt weapons are "cocked" by retracting the bolt assembly until it is locked in place by engaging the sear nose. To enable the sear to intercept the full auto bolt, it is necessary to incorporate a 90° shoulder on the base of the bolt. This shoulder is machined to the prescribed dimensions and is to remain "sharp". No burrs may remain, likewise the shoulder should not be chamfered or radiused. The heat treatment procedure will provide proper wear resistance to prevent damage at this point. It is this area in which Interdynamics USA had problems with earlier MP-9 SMG bolts being "soft" and wearing excessively.

4. OPTIONAL MODIFICATION - A slot exists in the base of both the semi and SMG bolts,

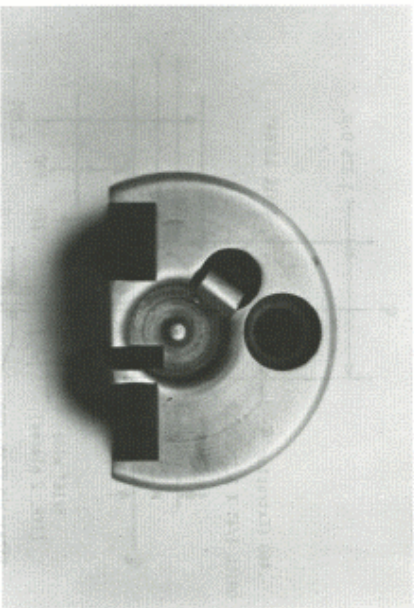

Close up view of front of SMG bolt. Note extractor, fixed firing pin, raised feed lip, recoil spring guide rod hole, and clearance notches for magazine feed lips and ejector.



Detail of sear engagement step on bottom of SMG bolt.

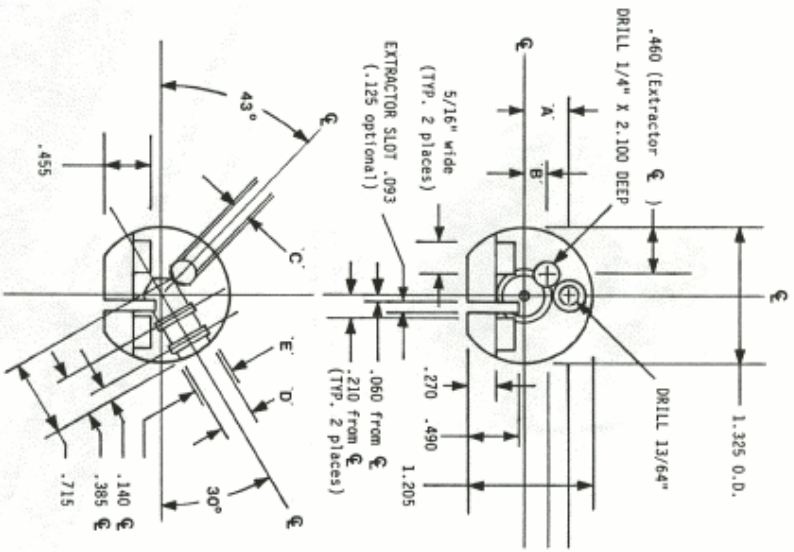

- A .430 to recoil spring guide hole centerline from bolt ϕ .
- B .207 to extractor hole centerline from bolt ϕ

FULL-AUTO BOLT

36

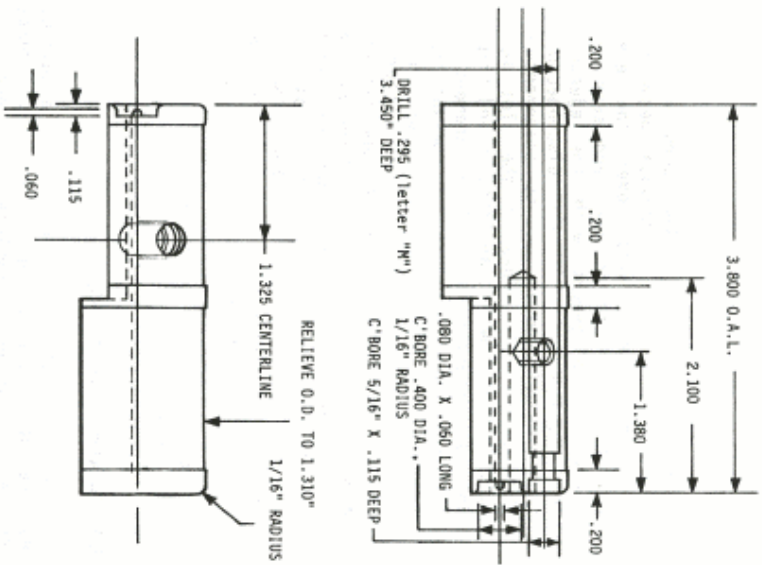

- C Drill (size #3) through intersecting Extractor hole. Thread 1/4" X 28 NF.
- D Drill letter "q" (.332) X .715 deep.
- E Groove diameter .385 X .080 wide - 2 places. Dimensions given to groove centerline.

37

identical in depth. The purpose of the slot is to provide clearance between the bolt which reciprocates over the ejector extending above the trigger and sear mechanisms. In alignment with the ejector is the disconnecter. If the ejector is bent or off center in its alignment with the ejector, the sides of the slot in the full auto bolt may cause friction and tripping the disconnecter out of engagement with the sear resulting in an un-anticipated stoppage. As a precautionary measure, machine the width of the slot to .125" rather than the standard .093". Use the same centerline dimension of the slot for reference. Extra side clearance is then achieved without affecting cartridge stripping or positioning in the bolt face. Also check the sides of the disconnecter for any burrs which may interfere in the slot area of the bolt.

This completes description of the full auto bolt differences.

HEAT TREATMENT OF THE BOLT

The bolt must be manufactured of a suitable heat-treatable steel, and then heat treated after all machining is completed. The particular steel used in fabricating the bolt in this manual was 1-3/8" diameter drill rod, which is an oil hardening variety known as 0-1.

Below are some of the more common heat treatable steels which may be encountered for use in fabricating the bolt, as well as heat treatment data. The first three listings are

38



The extractor is held in place by a socket head set screw through the side of the bolt, intersecting the extractor hole.

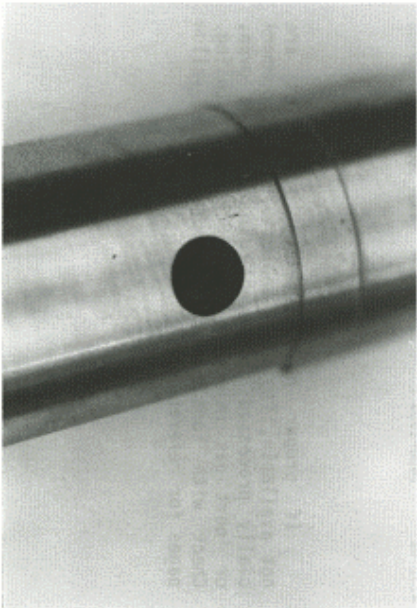

The bolt handle hole is drilled into the bolt body and grooved internally in two places to retain the bolt handle in "fire" and "safe" positions.

39

for common aircraft alloys, while the last three are for typical tool steel alloys.

TYPE	HARDENING TEMPERATURE	QUENCH	TEMPERING TEMPERATURE	ROCKWELL HARDNESS
SAE 4130	1600-1650°F	OIL	700-1250°F	35
SAE 4140	1550-1600°F	OIL	700-1300°F	50
SAE 4340	1475-1525°F	OIL	400- 500°F	50
AISI A2	1700-1800°F	AIR	350-1000°F	57-62
AISI D2	1800-1875°F	AIR	400- 100°F	54-61
AISI O1	1450-1500°F	OIL	350- 500°F	57-62

If proper heat treating facilities are not available, it is advisable to have it commercially processed, preferably in a vacuum oven, or inert gas injection oven to prevent scaling. Check with local machine shops or the yellow pages for references.

4

Assembly & Testing

The various parts to be deleted have been listed in previous chapters. These part are removed as follows:

1. The recoil spring guide is removed from the original bolt by supporting the buffer against a secure object and with one hand push the bolt downward toward the buffer slightly so that the E-ring can be reached near the end of the guide rod. Using a pair of small pliers, grip the middle edge of the E-ring and pull it out of the machined groove in the guide rod. The bolt may now be carefully removed from the guide rod. Be careful since the recoil spring is exerting tension against the bolt.
2. The striker spring guide will still be positioned in the buffer plate as the original bolt is removed from the recoil spring guide. After the bolt is removed, the firing pin, striker, and striker spring will be free. Take these off of the striker spring guide and set them aside. The striker spring guide can now be pressed rearward out of the buffer plate. The rear E-ring on the guide does not have to be removed. Place the striker spring guide along with the other removed parts.

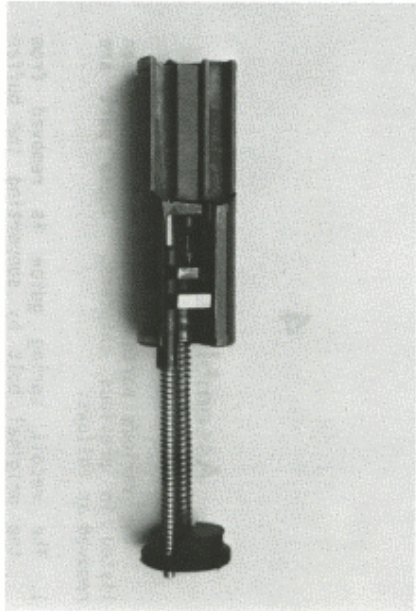

Complete semi-auto bolt assembly in inverted position. Note the striker engagements, one which engages the sear and one that trips the disconnecter.

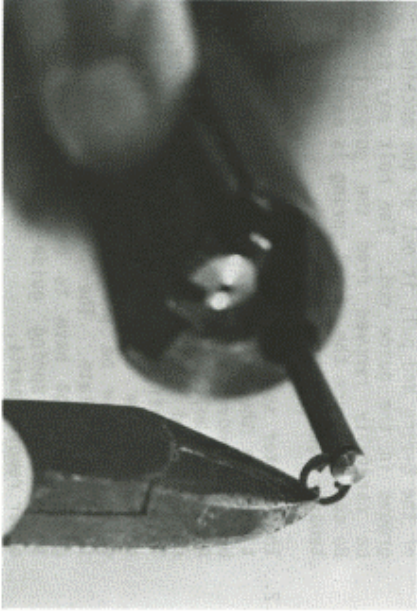

To strip the bolt assembly, push the bolt down on the guide rods and remove the "E-Ring" on the end of the recoil spring guide rod.

42

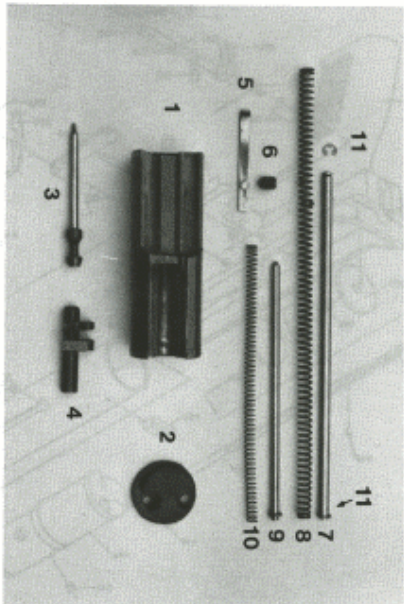

Semi-auto bolt assembly fully stripped:

1. Bolt
2. Buffer and Buffer Plate
3. Firing Pin
4. Striker
5. Extractor
6. Extractor Screw
7. Recoil Spring Guide Rod w/E-Ring (rear)
8. Recoil Spring
9. Striker Spring Guide w/E-Ring (rear)
10. Striker Spring
11. E-Ring

43

- 900 Barrel
- 954 Rear sight
- 929 Upper receiver sub-assembly
- 930 SMG open-bolt
- 131 Extractor
- 132 Extractor screw
- 933 Operating handle
- 934 Operating handle spring
- 140 Recoil spring
- 940 Recoil spring - Mini
- 941 Recoil spring guide rod
- 144 E-Ring
- 950 Frame (lower receiver)
- 152 Rear cover
- 958 Buffer
- 959 Buffer plate
- 156 Screw
- 151 Assembly pin
- 160 Trigger
- 161 Trigger axis
- 162 Trigger spring
- 170 Disconnecter
- 171 Disconnecter axis
- 172 Disconnecter spring
- 980 Sear
- 181 Sear axis
- 185 E-Ring
- 183 Sear retainer (not shown)
- 982 Sear spring
- 190 Magazine catch
- 191 Magazine catch axis
- 192 Magazine catch spring
- 200 Ejector
- 210 Magazine assembly (complete)

44

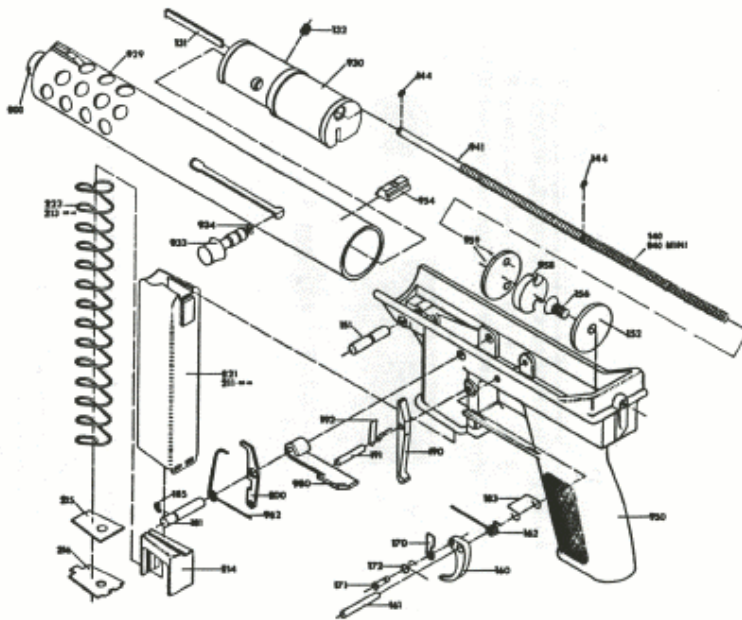

Exploded view of the KG-99 open-bolt SMG.

3. Using a 1/8" allen wrench, remove the socket head set screw retaining the extractor from the old bolt. Note the position of the extractor "claw" in relationship to the recessed bolt face before removal. The extractor will slide out of the front of the bolt at this time. This bolt may now be placed with the other deleted components.
4. Place the extractor into the corresponding hole in the face of the new bolt. Screw the socket head extractor screw into the threaded hole in the side of the new bolt. Check position of the extractor and tighten the retaining screw. Check the "claw" for proper depth.
5. The new bolt may now be assembled to the recoil spring guide/buffer assembly. The recoil spring guide should still be assembled to the buffer plate and buffer. A single E-ring will be in position in a machined groove near the rear end of the guide rod. This ring will be on the rear side of the buffer plate. The recoil spring should be positioned over the rod, and in a free condition extend past the end of the rod, about 2-3/16".
6. Place the new bolt over the end of the recoil spring, aligning the spring in the appropriate hole which passes through the bolt. Make sure the buffer plate is against a secure object and gripping the bolt with one hand, push the bolt down against the recoil spring until the end of the recoil spring guide rod extends past the bolt face. The machined groove for the front E-ring will be seen. Snap the E-ring in the groove and over the

45

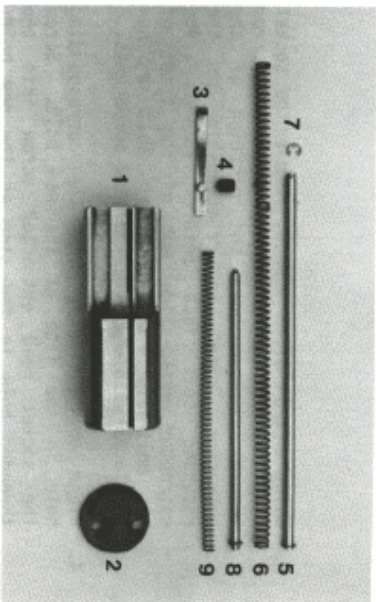

SMG Bolt Assembly field stripped: NOTE Items 8 & 9 are now deleted and not necessary for the SMG conversion.

1. Open Bolt
2. Buffer and Buffer Plate
3. Extractor
4. Extractor Screw
5. Recoil Spring guide rod with rear E-Ring
6. Recoil Spring
7. E-Ring

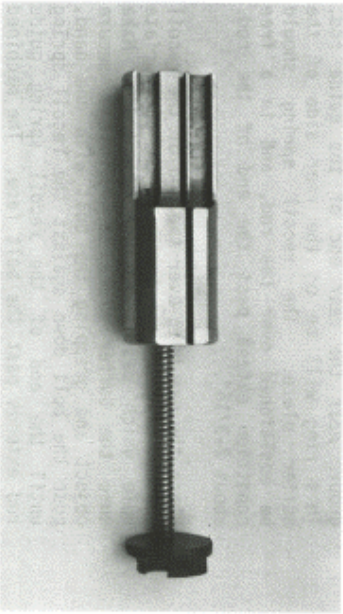

SMG Open-Bolt assembly ready for final assembly in upper receiver.

7. Place the bolt assembly into the rear of the upper receiver, positioning it so that the bolt handle hole in the bolt corresponds with the large hole at the rear of the bolt handle slot in the upper receiver. Insert the bolt handle until the spring-loaded ball in the handle shank engages the first internal groove. Slide the handle and bolt assembly all the way forward.

8. The upper receiver is now ready to assemble to the lower receiver. The rear of the upper receiver is positioned onto the stationary rear cover disc at the rear of the lower receiver. The front of the upper receiver is elevated slightly at this time. When the two are in position, push the upper receiver down onto the lower receiver, aligning the assembly pin hole and pressing the assembly pin through both receivers until flush.

9. Pull the bolt handle back, checking for drag or friction. The sear should rise and intercept the bolt after passing the engagement step on the bottom of the bolt. Maintain rear pressure on the bolt handle and press the trigger. The sear should release and the bolt then can be eased forward. Maintain pressure on the trigger and cycle the bolt back and forth fully several times to check for excess friction. If this checks out all right, place a dummy round into the magazine, load the magazine

FULL AUTO

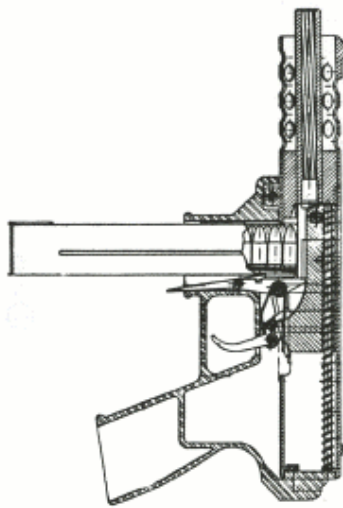

KG-99, KG-99 MINI TEC-9, TEC-9 MINI

FULL AUTO CONVERSION MANUAL

into the weapon securely, cock the weapon, and dry fire. The bolt should slam forward, successfully stripping and chambering the round without jamming. If this can be completed several times without feeding jams, the weapon can be tested with live ammunition. This is to be done using one round in the magazine at a time at first. If no problems result, work up in capacity one round at a time until satisfied that the sear will intercept the bolt when attempting burst firing. Once the function of the weapon is proven, full magazines may be tested to see if the pressure of 36 rounds in the magazine causes any problems with partial cartridge stripping and feeding jams when firing.

If more than one magazine is to be used, check all for proper functioning. If magazines are dropped, check the tips for deformation which would cause misfeeds. Once all of the tests are completed, the user can practice, working on firing short bursts of 3-5 rounds. That is the most practical method of using any SMG since the hit probability increases when short bursts are fired rather than "hosing" a target. The firing rate will be approximately 800-900 rounds per minute.

Weapons in this configuration are ideal for a variety of situations, such as self-defense weaponry for military airmen, vehicular crews and drivers, medical corpsmen, radio operators, officers, military and civilian law enforcement officers (especially when working undercover requiring maximum concealment), SWAT teams, border guards, drug enforcement officers, and executive protection details.