



TELEPHONY.

---

PART II.

THE CONSTRUCTION OF UNDERGROUND  
CONDUITS.



---

# TELEPHONY

*A MANUAL OF THE  
DESIGN, CONSTRUCTION, AND OPERATION  
OF TELEPHONE EXCHANGES*

IN SIX PARTS

PART II.  
CONSTRUCTION OF UNDERGROUND CONDUITS  
WITH 62 ILLUSTRATIONS

BY  
ARTHUR VAUGHAN ABBOTT, C. E.

---

NEW YORK  
McGRAW PUBLISHING COMPANY.

1903

Eng, 4289, 03.3

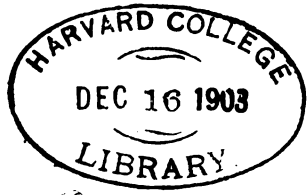

*Three funds.*

~~90.8~~  
**JUN 20 1917**     24.2  
TRANSFERRED TO  
HARVARD COLLEGE LIBRARY *17II*

COPYRIGHTED, 1903,  
BY THE  
MCGRAW PUBLISHING COMPANY,  
NEW YORK.

## PREFACE.

---

THE art of Conduit building may be considered to owe its inception and development to the Telephone Exchange, for electric light and power circuits would have encumbered city streets much longer had it not been for the phenomenal increase in overhead wires necessitated by the telephone. When telephonists solved the problem of the underground circuit and buried their lines, other circuits of all descriptions were compelled to follow; and to Telephone Engineers, as conduit builders, the improved appearance of city streets owe a huge debt of gratitude. As with other inventions, the successful conduit has been a struggle for the survival of the fittest. During the past two decades plan after plan for underground circuits has appeared, lived for a time, and died; but gradually, from the ruins of failure, a system of Conduit building has arisen which has successfully withstood the severe test of more than a decade beneath the streets.

The present volume deals little with the history of Conduit construction; for discarding the attempts of the past, it endeavors to portray and describe the Conduit forms of the present, such as experience has sanctioned; and the methods of building that have been tried and proved adequate.

To the practicing engineer the question of costs is always a vital one ; and while prices must necessarily vary, both in time and place, it is hoped that the methods of estimating herein described, and the information upon Conduit expense contained, will prove of value in the estimation of this portion of telephone practice.

ARTHUR VAUGHAN ABBOTT.

NEW YORK, March, 1903.

# TABLE OF CONTENTS.

## *PART II.*

CHAPTER	PAGE
I. THE WIRE PLANT . . . . .	1
II. DUCT MATERIALS . . . . .	7
III. CEMENT DUCTS . . . . .	15
IV. MANHOLES . . . . .	43
V. DISTRIBUTION . . . . .	65
VI. OBSTACLES . . . . .	74
VII. COST OF CONDUITS . . . . .	84
VIII. ANNUAL CHARGES . . . . .	102
IX. CONDUIT BUILDING . . . . .	107





# LIST OF TABLES.

## PART II.

TABLE		PAGE
1.	THE WIRE PLANT . . . . .	1
2.	VALENTINE DUCT MATERIAL . . . . .	10
3.	CONDUIT SIZES . . . . .	38
4.	COST OF MANHOLES IN DOLLARS . . . . .	86
	(a) Brick with Brick Roof.	
	(b) Brick with Concrete Roof.	
	(c) Concrete Manhole.	
5.	COST OF SEWER CONNECTIONS IN DOLLARS . . . . .	87
6.	CONSTANT COST PER CONDUIT FOOT FOR MANHOLES IN DOLLARS	88
7.	COST OF PAVING PER SQUARE YARD, AND PER FOOT OF CONDUIT IN DOLLARS . . . . .	91
8.	COST OF STREET EXCAVATION PER CONDUIT FOOT IN DOLLARS	92
9.	CONSTANT COST PER CONDUIT FOOT IN DOLLARS . . . . .	93
10.	COST OF DUCT MATERIAL IN PLACE IN DOLLARS . . . . .	95
A.	CONTRACT PRICES TO BE PAID PER CONDUIT FOOT . . . . .	127
B.	DIMENSIONS OF MULTIPLE DUCT PIECES . . . . .	132
C.	VALENTINE DUCT MATERIAL, SIZES OF CONDUIT . . . . .	136



# LIST OF ILLUSTRATIONS.

## PART II.

---

FIGURE	PAGE
1. BOX CONDUIT . . . . .	8
2. ROUND PUMP LOG . . . . .	9
3. SQUARE PUMP LOG . . . . .	9
4. VALENTINE CONDUIT . . . . .	11
5. FOUNDATION FOR VALENTINE CONDUIT . . . . .	12
6. CEMENT-LINED PIPE SUBWAY . . . . .	18
7. CEMENT-LINED PIPE CURVE . . . . .	20
8. LAYING CONDUITS . . . . .	22
9. "TEN BY TEN" . . . . .	23
10. HOLLOW-BRICK DUCTS . . . . .	23
11. MANDREL FOR HOLLOW BRICK . . . . .	24
12. SHOWING USE OF MANDREL . . . . .	24
13. PARTIALLY COMPLETE HOLLOW BRICK CONDUIT, SHOWING MANDRELS . . . . .	27
14. COMPLETED CONDUIT TRENCH READY TO REFILL . . . . .	28
15. MULTIPLE DUCT . . . . .	30
16. MAKING JOINTS ON MULTIPLE DUCT CONDUIT . . . . .	31
17. MULTIPLE DUCT CONDUIT . . . . .	32
18. MULTIPLE DUCT CONDUIT WITH TIMBER FOUNDATION . . . . .	33
19. CEMENT PIPE AND DUCTS . . . . .	34
20. MULTIPLE DUCT CURVE . . . . .	35
21. TYPES OF SINGLE-DUCT CONDUIT . . . . .	35
22. SOME MULTIPLE DUCT FORMS . . . . .	36
23. ROUND-HOLE MULTIPLE DUCTS . . . . .	37
24. GROUPINGS OF MULTIPLE DUCTS . . . . .	39
25. SUBWAY OF 34- SINGLE-DUCTS . . . . .	41
26. MULTIPLE DUCTS . . . . .	42
27. ELECTROLYSIS-PROOF CONDUIT . . . . .	43
28. MANHOLE INTERIOR . . . . .	47

FIGURE	PAGE
29. STANDARD MANHOLE . . . . .	48
30. TYPICAL BRICK MANHOLE . . . . .	51
31a. FIRST COURSE FOR RAIL ROOF . . . . .	52
A. Rails in Place.	
B. Masonry in Place.	
31b. LAST COURSES FOR RAIL ROOF . . . . .	55
C. Setting Masonry.	
D. Bails in Place.	
E. Ready for Cover.	
32. MANHOLE WITH ARCHED ROOF . . . . .	56
33. SPECIAL MANHOLE, ARCH BRICK . . . . .	57
34. CIRCULAR TIGHT MANHOLE COVER, OVERHUNG INNER COVER . . . . .	58
35. CIRCULAR TIGHT MANHOLE COVER, UNDERHUNG INNER COVER, . . . . .	59
36. BALTIMORE MANHOLE, FRAME AND COVER . . . . .	60
37. OPEN MANHOLE COVER . . . . .	61
38. SQUARE MANHOLE COVER . . . . .	62
39. WATERPROOF MANHOLE . . . . .	63
40. MANHOLE WITH LATERAL CONNECTION . . . . .	66
41. ALLEY LINE FOR DISTRIBUTION . . . . .	67
42. CROW'S NEST DISTRIBUTING POLE . . . . .	67
43-44. TILE SERVICE DISTRIBUTION BOX WITH IRON SURFACE COVER . . . . .	69
45. IRON SERVICE BOX FOR THREE-WAY CONDUIT, TWO SERVICES, . . . . .	70
46. LATERAL CONNECTION TO MAIN DUCT . . . . .	71
47. JOHNSTON'S DISTRIBUTING DUCT . . . . .	72
48. CARRIER FOR JOHNSTON DUCT . . . . .	72
49. HARRISON STREET AND WABASH AVENUE, CHICAGO . . . . .	75
50. MANHOLE, MARKET AND WASHINGTON STREETS, CHICAGO . . . . .	76
51. A NEW YORK STREET CORNER, SHOWING UNDERGROUND PIPE CONSTRUCTION . . . . .	77
52. TEST PITS . . . . .	79
53. VENTILATING SYSTEMS . . . . .	81
54. COST PER CONDUIT FOOT: AVERAGE . . . . .	96
55. COST PER CONDUIT FOOT: AVERAGE . . . . .	97
56. COST PER DUCT FOOT: AVERAGE . . . . .	98
57. COST PER DUCT FOOT: MAXIMUM . . . . .	99
58. NUMBER OF DUCTS . . . . .	100

# TELEPHONY.

## CHAPTER I.

### THE WIRE PLANT.

STRETCHING between the sub-stations and the central office extends the wire plant, an enormous copper network, outrivaling in intricacy and complexity the elaborate creations of the most ingenious of the geometricidæ. Unfortunately in the construction thereof the telephonic arachnid cannot in the least depend upon any inherited instinct like his crustaceous confrère, but must design and spin his web on what grounds of logic and probability he may, trusting to the future to justify or condemn the result.

To deal with the conducting system in a comprehensive manner, it is convenient to analyze it according to the following table :

TABLE No. I.

Wire Plant.	{	Type.	{ Aerial.	{	Open wire.	Distribution	{	House top wire.
			{ Underground.					
		Quantity.	{ Block system.					{ Back lot lines.
			{ Multiple terminal system.					

It is now proposed to describe in a general way each of the preceding heads, to supplement these descriptions by detailed specifications under which, with such modifications as would be necessitated by changes in time and location, a wire plant could be constructed, and finally, subject to the specifications, to calculate the wire plant cost.

Considering the table, it is seen that the first subdivisions are those of "*Type and Quantity.*" The quantity of wire plant needed will depend on the area of the district, number of stations to be served, and the method of distribution; but as the total cost of the plant is a question of both *Type and Quantity*, — for example, underground wire, if there is a sufficient amount, will cost less than one-third as much per wire mile as overhead wire, — it is well to commence the analysis with a consideration of the various types.

Historically it is hard to assign priority to either underground or aerial construction, for the original experiments of Morse on the Baltimore-Washington line were commenced with a gutta-percha covered wire buried in a trench dug in the earth. The means at the command of Morse were inadequate to secure permanent insulation, and as a temporary expedient the first telegraph line was strung on poles. Contrary to expectation, this device yielded satisfactory results, immediately becoming standard practice, and — with the exception of subaqueous cables — the sole method until the middle 80's, when the introduction of the electric light and the rapidly extending use of both telegraph and telephone required the erection of pole lines of such enormous dimensions as, on the

one hand, to become impractical from both a constructive and maintenance standpoint to the operating company, and on the other, an unbearable nuisance and encumbrance to city thoroughfares. Some method of relief was necessary, and the only conceivable one was that of placing the objectionable circuits underground. Early inventors attacked the subterranean wire problem from two standpoints: one class followed the example of the Atlantic cable designers, attempting to manufacture all kinds of electric conductors into cables having sufficient mechanical strength to protect the inclosed circuits from injury, either during the process of laying or subsequently thereto. On this plan the finished cable is the entire structure, merely needing to be dropped into the trench dug in the highway and covered up. Such so-called "*Built-in Systems*" have found considerable favor for telephone and telegraph installations in Europe, but in America it has appeared too difficult and too expensive to make proper cable to withstand the predatory pickaxe of the average street paver, and, further, after completion such systems are found so inelastic, and lend themselves so reluctantly to any changes in distribution, that this plan has only found extensive favor with the low-tension multiple-wire distribution of the Edison companies, and in the Edison tube has reached its highest and most extensive development. For telephone work, therefore, "*Built-in Systems*" need no further exposition.

The other set of inventors conceived the idea that the true solution of the problem consisted in building a good substantial "*hole*" in the street, into which the circuits could be introduced and removed at pleasure, and strong

---



enough to amply protect from all outside interference the contained conductors; requiring the cable only to maintain the requisite electrical insulation. The "*Drawing-in Systems*," therefore, while requiring a greater expenditure both initially and finally in street structures, reduce to a minimum cable cost, permit of easy rearrangement, minimize maintenance, and so have furnished a method that is sufficiently elastic to meet requirements of the service. For these reasons the various conduit systems have, with the exception of the low-tension Edison networks, been adopted for all kinds of electrical distribution in cities of any magnitude, and their manifold advantages are causing extensions of underground wire plants into even the smaller towns.

From an engineering aspect, and from the broad idyllic standpoint of that which will produce the greatest good to the greatest number, the typical "*hole*," or conduit, is a subterranean tunnel, large enough to permit workmen to have access from end to end, and so designed as to accommodate every form of subterranean structures — gas, water, electric wires of all kinds, steam pipes, pneumatic tubes, sewer facilities, etc. — that are needed in the modern city. The Parisian sewer system is the only one in which even a partial attempt has been made to approximate to this end. In all other cases the expense of such construction has made it impossible of realization without the concerted action of all parties concerned therein, and this, owing to the many conflicting interests, has not as yet proved feasible; consequently, in the main, each corporation has constructed its own subway as best it might, so that it is not unusual to find one or more sewers occu-

pying the center of a street, several lines of gas pipe and water pipe extending along either side, while the telephone, telegraph, electric light conductors, with an occasional pneumatic tube and steam heating pipe snugly nestle together, threading their way as best they may in whatever space remains.

The problem in conduit construction is to get the best hole for the least money. As electrical conductors are universally made up in cable form, possessing a considerable degree of flexibility, rarely over three inches in diameter, the unit of conduit construction becomes a single duct, capable of accommodating one cable. In earlier days the plan of building ducts capable of containing several cables side by side gained considerable currency. So far as the introduction of the cable was concerned, no difficulty arose, but after the duct was filled with say three cables or more, and subjected for a considerable time to the impacting influence of the débris that in a most astonishing manner finds its way in the tightest conduit, it became a difficult or almost impossible matter to remove one cable without injuring or destroying the sheaths of the others. Thus, experience has declared itself so emphatically and unhesitatingly in favor of the individual cable space that no other form should for a moment be considered.

The present method of conduit building, therefore, resolves itself into obtaining a pipe-like structure or conduit material capable of inclosing the cable, making the necessary excavation in the street in which the ducts may be laid, the placing of the ducts in such a position as to produce a series of longitudinal tubes, the protection of the

duct material by some substance that shall resist the onslaughts of the ignorant pick and shovel, the refillment of the excavation and replacement of the paving.

The ideal conduit should be moisture proof and gas tight. It should be indestructible when laid in street soil, strong enough mechanically, so that the Tammany street paver may pick away at it until he is tired without inflicting any injury, easily, rapidly and cheaply laid, and while the ducts should present a smooth surface to the introduction of the cables, they must contain no substance that can injure the lead sheath. Finally, high electrical insulation is desirable as a protection against the electrolysis of the cable sheath, due to parasitic electric currents. There is no subway that perfectly fulfills all these conditions, though each conduit manufacturer optimistically claims that his particular brand will, but there are a multitude of different makes that in varying degrees realize a portion of the preceding conditions, while all of the manufacturers now offer a material which the telephone engineer may safely use, and which if carefully selected, and installed under rigid specifications, will yield a subway that is of practical utility in all respects — the selection between different duct material makers depending chiefly upon the relative prices quoted by their respective agents.

## CHAPTER II.

## DUCT MATERIAL.

THE bulk of duct material now on the market, certainly all that is worthy of serious consideration by the telephone engineer, will fall into one of the following four classes:

1. Wood ducts.
2. Cement ducts.
3. Vitrified clay ducts.
4. Asphalted or bituminized wood-pulp ducts.

Wood was the earliest of the duct material used, and at its first appearance took the form of a wooden box about 8 ft. long, made of 1½-in. creosoted yellow pine or similar wood. As is indicated in Fig. 1, it was easy to build the box in any convenient length, and to construct as many different ducts as the design of the conduit required.

A little later the familiar pump log in its round or square form, as illustrated in Figs. 2 and 3, displaced the box as being mechanically much stronger, cheaper to build by machinery, more flexible as to the number of ducts, and slightly less expensive to lay — particularly when a large capacity was contemplated. The Valentine duct and its congeners is illustrated in Fig. 4. This duct material consists of a series of wooden slabs, each one hav-

ing a number of semi-circular grooves. The grooves are so arranged that when the slabs are piled up, a series of circular holes are produced. It is thus easy to build a conduit of any desired capacity by the simple process of

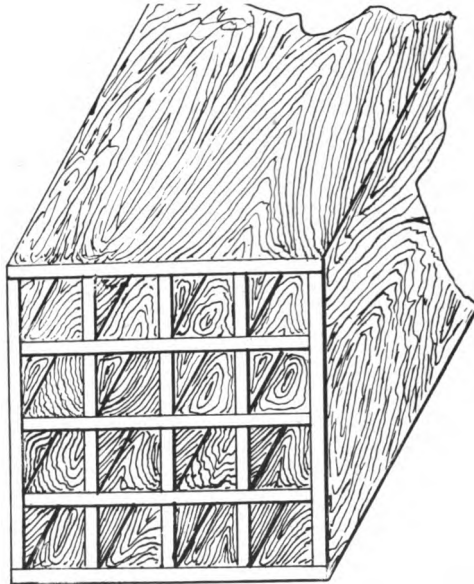

*Fig. 1. Box Conduit.*

laying up tiers of wood. In Table II. (see page 10) will be found the dimensions of wood work for conduits of this style, containing varying number of ducts of various sizes :

The street construction involved in laying wooden ducts is exceedingly simple. A trench of sufficient size to accommodate the requisite number of ducts is excavated, and the bottom carefully leveled. A very desirable, though not essential addition, is a bottom layer of plank,

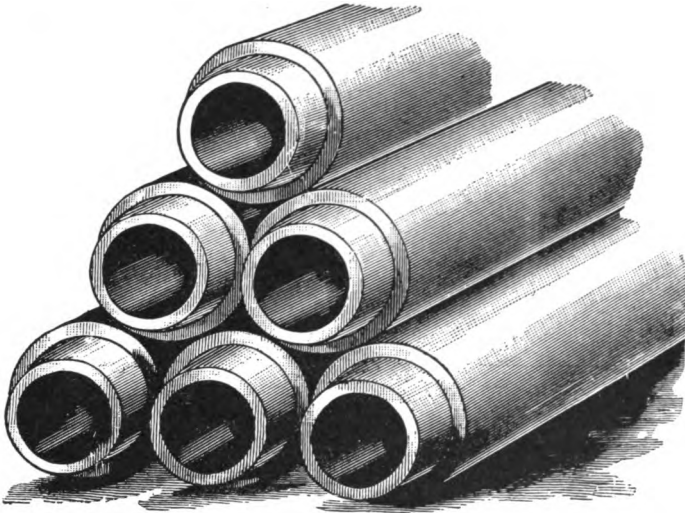

*Fig. 2. Round Pump Log.*

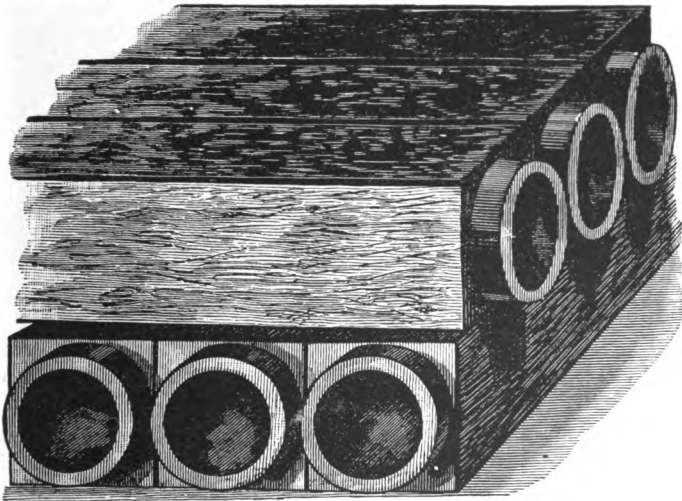

*Fig. 3. Square Pump Log.*

TABLE No. II.

*Valentine Duct Material.*

SIZES OF CONDUIT.				INCHES.
<b>1½-IN. CONDUIT.</b>				
Conduit containing 1 duct, dimensions				3 × 3
“ “ 2 ducts, “				3 × 5½
“ “ 3 “ “				3 × 7½
“ “ 4 “ “				5¼ × 5¼
“ “ 6 “ “				5¼ × 7½
“ “ 9 “ “				7½ × 7½
“ “ 12 “ “				7½ × 9¾
<b>2-IN. CONDUIT.</b>				
Conduit containing 1 duct, dimensions				3½ × 3½
“ “ 2 ducts, dimensions				3½ × 6¼
“ “ 3 “ “				3½ × 9
“ “ 4 “ “				6¼ × 6¼
“ “ 6 “ “				6¼ × 9
“ “ 9 “ “				9 × 9
“ “ 12 “ “				9 × 11¾
<b>2½-IN. CONDUIT.</b>				
Conduit containing 1 duct, dimensions				4 × 4½
“ “ 2 ducts, “				4½ × 7¾
“ “ 3 “ “				4½ × 11
“ “ 4 “ “				7¾ × 7¾
“ “ 6 “ “				8 × 11
“ “ 9 “ “				11 × 11½
“ “ 12 “ “				11 × 15
<b>3-IN. CONDUIT.</b>				
Conduit containing 1 duct, dimensions				5 × 5
“ “ 2 ducts, “				5 × 8¾
“ “ 3 “ “				5 × 12½
“ “ 4 “ “				8¾ × 8¾
“ “ 6 “ “				8¾ × 12
“ “ 9 “ “				12½ × 12½
“ “ 12 “ “				12½ × 16¼

as shown in Fig. 5; or, better still, a stratum of three inches of clean sharp sand or gravel that may serve both as a bed for the timber and as a sub-drain to carry away any ground water that may subsequently accumulate. In particularly wet localities the sand, or even a line of open drain tile, may not only be desirable but necessary. When the bed is prepared, the first layer of wood is placed thereon, and gently—to avoid splitting—rammed to a good bearing. When the single duct or pump log forms, illustrated in Figs. 2 and 3 are used, the male ends of each piece should be dipped into hot pitch or tar, then driven firmly home into the female sockets of the preceding ones. In the Valentine or other similar

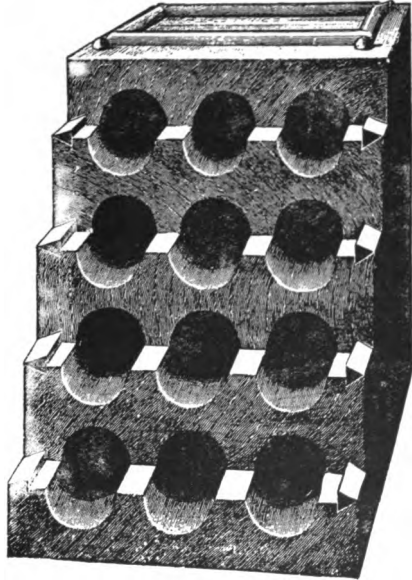

*Fig. 4. Valentine Conduit.*

form, there is either a piece of felt or a kind of dovetail to be covered with hot tar and inserted between the outside joints of each slab. It is also well to place a piece of tarred paper or roofing felt around each joint, and tack the same in place with wood battens. Protection from foreign picks is afforded by placing on the top, and



preferably on each side, a 1½-in. or 2-in. plank. A layer of sand on the top and sides also adds materially towards keeping the conduit dry. In the single duct conduit

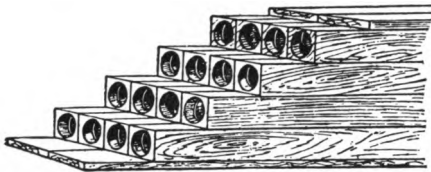

Fig. 5. Foundation for Valentine Conduit.

natural spring of the timber and its joints. With the Valentine, curves are accomplished by cutting the timber into short lengths and miter-

ing the joints. As fast as the duct material is placed, the trench may be refilled and temporary paving placed. To lay the single duct wood conduit requires no skilled labor other than that of a vigilant foreman, while with the Valentine, one carpenter to cut and place the battens and miter for curves will keep a large gang busily employed.

It is hardly necessary to call attention to the necessity of treating the timber with some form of preservative, as otherwise decay — when buried in the street — becomes exceedingly rapid. Probably the consensus of opinion is in favor of creosoting; but this or any preserving process, to be of value, must be carried out with exceeding care and thoroughness. As far as possible all forming and cutting should be done prior to treatment, as it is natural to expect the surfaces of the wood to be the most thoroughly impregnated.

In creosoting, the first operation is that of steaming, which is accomplished by treating the wood in a closed retort for from two to three hours, with steam pressure of from 25 to 50 lbs. The air pump is then applied and a

vacuum of at least 20 in. maintained in the retort so long as there is any flow of sap from the timber. The retort is then pumped full of dead oil of tar, and the whole subjected to an hydrostatic pressure of at least one hundred pounds to the square inch. Most scrupulous care must be exercised to see that pure dead oil of tar is employed for impregnation, otherwise the destruction of the cable sheath is simply a question of time. A chemical analysis of the oil used should be required. In order to secure the desired amount of impregnation, the hydrostatic pressure should be maintained for at least three hours, and, finally, no timber should be accepted that does not show an absorption of at least 14 lbs. of oil per cubic foot.

After creosoting, the ducts should be allowed to season in the air for some time, two or three months if possible, in order to dispel any possible remains of phenol in the oil, for in the early use of creosoted wood considerable difficulty was experienced with the formation of lead carbonate and the consequent perforation of the cable sheath and the destruction of the cable. So much difficulty was experienced from this source that the use of creosoted wood for conduit purposes was practically condemned. Further experience, however, proved that if pure dead oil of tar was used, and the ducts after treating were thoroughly seasoned, no apprehension need be entertained from any corrosive action upon the cable sheath. Creosoted wood ducts possess the advantage of cheapness, ease of handling, rapidity of construction, flexibility, facility in distribution, for from any duct a wire may be taken by the simple process of opening the street and boring a hole in the side of the conduit. Per contra, they are by no

means moisture or gas proof, have only medium insulating qualities and are in no wise indestructible — being credited with a probable life of about 15 years, and are not completely free from the suspicion of originating injury to the cable sheath. For these reasons creosoted wood finds its place in the conduit systems of small towns, and in the laterals and subsidiary ducts of rapidly growing portions of cities where great economy of installation and short probable life of the conduit are likely, but for the main lines and heavy leads of the permanent subway of important cities some of the other and more permanent forms of ducts are preferable.

**CHAPTER III.****CEMENT DUCTS.**

ONE of the earlier pieces of conduit construction is the system in New York installed by the Empire City Subway Company. In the commencement of this work the plan of embedding wrought-iron pipe in concrete was adopted, on the theory that while in time the pipe might, and probably would, rust away, a sufficient interval would elapse to permit the concrete to become perfectly hard, so that if the pipe did disappear a continuous concrete block pierced with a corresponding number of holes would remain. Experience has verified this expectation, and in many places at least the iron has vanished, but the concrete holes remain, forming a most excellent duct system. There are two objections to this plan: the iron pipe is exceedingly expensive, costing from 15 to 20 cents per foot (depending on the price of iron), exclusive of the cost of laying or street work. So long as the pipe is intact a serviceable tube is gained, and after oxidization has completely destroyed the metal the concrete tube is equally good, but an interval exists when the pipe is partially destroyed when the ducts may be filled with sharp jagged slivers of partially corroded iron that are likely to destroy the cable sheath in drawing in and out.

To minimize expense and avoid injury to the cable sheath many attempts were made to fashion a tube of some other material, but only two of these have survived the test of time and have gained any considerable vogue in the conduit field.

The first of these to appear was the so-called "*Cement-Lined Pipe*." The manufacture of this duct has been brought to a high state of perfection by the National Conduit and Cable Company. The process consists of first fashioning a tube about 4 in. in diameter by riveting up thin sheet-iron after the fashion of a stove-pipe. A mandrel about 1 inch less in diameter than the tube is then inserted therein, the remaining space rammed full of hydraulic cement. After the cement is set the mandrel is withdrawn, leaving a composite pipe, consisting of a sheet-iron exterior and a lining of cement. The iron casing forms a mold to retain the cement in position during the process of hardening, and continues to protect it during the somewhat trying process of shipping, handling, carting, and laying in its concrete bed in the street. As with iron pipe, the idea is advanced that if the sheet casing rusts away after the pipe is laid, no harm can result, as by that time both the cement lining and the concrete matrix of the conduit will have ample time to completely solidify. Further, it is argued that the casing being completely inclosed in cement and concrete it will not oxidize to destruction. Which of these theories is true matters little — probably both are — for in some cases the casing does entirely disappear, and in others it is preserved; but as far as the serviceability of the conduit is concerned no difference can be detected, and it is immaterial whether

the iron rusts or not. Cement-lined pipe is usually made with a bore about 3 inches in diameter, in lengths of about 5 feet. Each piece is supplied with a male and female socket, somewhat similar to the pump log, so that successive lengths may be centered and fitted into the preceding ones. After the trench in the street has been excavated and the bottom graded, a layer of about 3 inches of concrete is carefully spread thereon and leveled. On this, as a bed, the first row of ducts are placed, spaced about 5-in. centers, lightly tamped in place. Then a concrete of fine stone or a very coarse mortar is spread over the ducts, filling completely all interstices between them. A sufficient clearance is placed on top of the pipes so that the next row may be spaced about 5 in. vertically. As each piece is laid it is driven home on the preceding one, and mortar packed tightly about the joints. When a sufficient number of pipe have been laid to gain the desired cross-sectional number of ducts, 3 inches of concrete are packed about the sides and on top, and the street refilled and paved.

Fig. 6 gives a detailed view of cement-lined pipe construction, while Fig. 7 shows the general method, illustrating the flexibility of this form of duct in turning a curve. Cement-lined pipe meets a large number of specifications for ideal duct material, and so has deservedly won over many friends, hundreds of thousands of feet being in successful operation. It forms, with its concrete incasement, a strong and indestructible conduit, is easily and rapidly laid without skilled labor, and while by no means either moisture- or gas-proof, it is as much so as most market forms. The duct surface is reasonably smooth

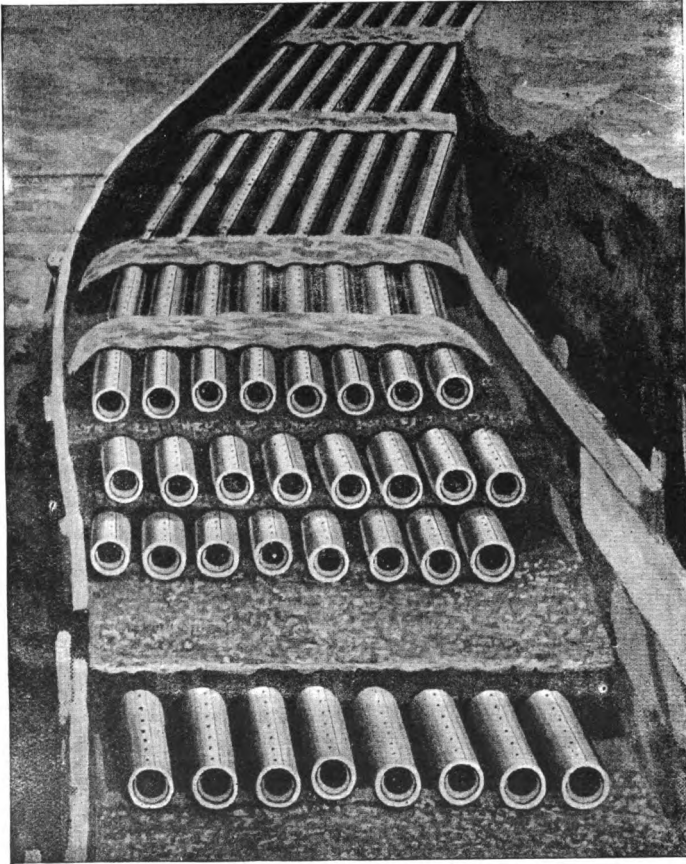
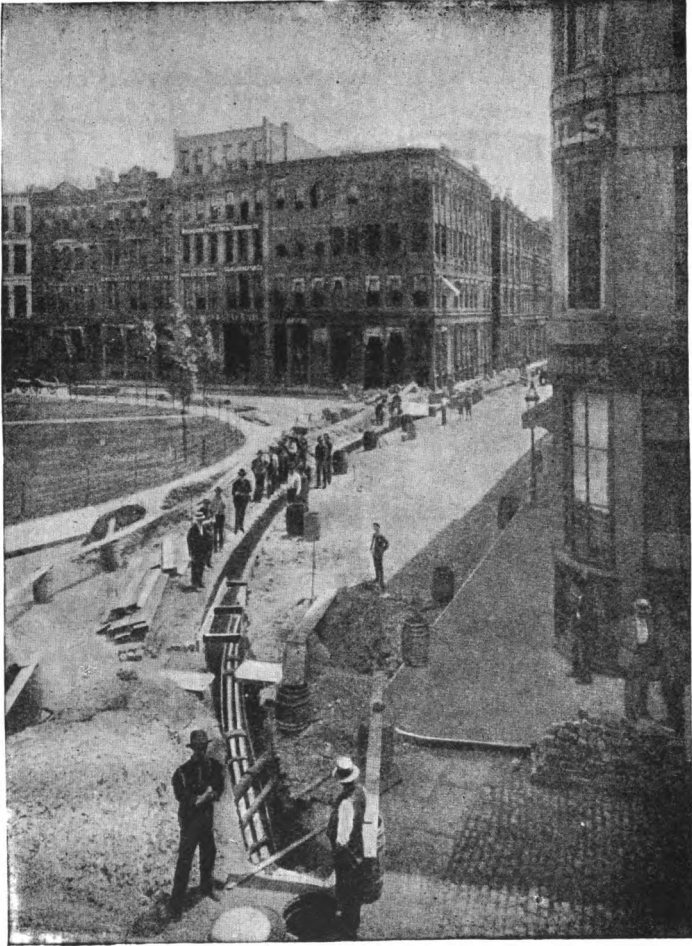

*Fig. 6. Cement-lined Pipe Subway.*

and cables pull easily. It has as good insulation as any form of silicious duct material. Its chief handicap has been the price charged per duct foot by its manufacturers, which — notwithstanding the fact that the installation cost of cement-lined pipe is less than that of several other forms — has made the total expense per duct foot of conduit built of this material greater than that of some other kinds.

Within the past few years several attempts have been made to cheapen cost of manufacture by avoiding the use of the objectionable sheet-iron casing. These processes have taken the form of manufacturing a concrete tube from a mixture of Portland or other superior brand of hydraulic cement and very sharp crushed rock, pressing the same into a tubular form, either in a mold or through a die. The Francis duct and that manufactured by the Western Stone Conduit Construction Company are the best examples of these attempts. The pieces are made in lengths of five to six feet, but no socket joints are provided. Duct material is laid in concrete, exactly in the same manner as cement-lined pipe, excepting that the joints are simply butted, a tightly fitted rubber mandrel being placed at each joint, while the concrete is tamped around it, thus easily insuring good alignment. The advocates of this form of duct material claim that, owing to the absence of the metal casing, a much more perfect union between the incasing concrete is gained, and thus a stronger and more homogeneous structure; that the absence of the socket joint does not in any way militate against its value as a duct material. As the pipe can be readily cut with an ordinary bucksaw, breakage is min-



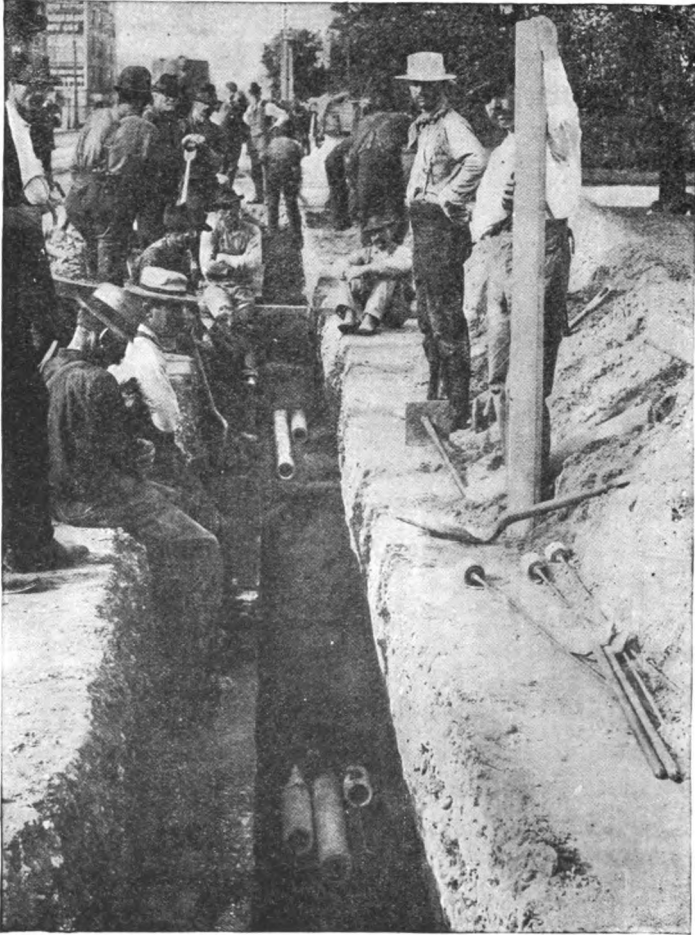

*Fig. 7. Cement-lined Pipe Curve.*

imized, and no special short lengths are needed to complete sections. Theoretically, all these claims are probably true, but practically they are imperceptible in the actual working of the conduit in contrast with that built of other forms of duct material. Cement-pipe of this description is quite rough on the inside, and cables pull hard, nor does the absence of the iron casing cause its manufacturers to quote prices that have as yet gained for it a widespread introduction. An example of the practice of the Western Stone Conduit Construction Company's work will be found in Fig. 8.

#### VITRIFIED CLAY DUCTS.

History is silent as to the inventor of the vitrified clay duct—that very popular, and, on the whole, most valuable of duct material. Probably some ingenious but unassuming engineer pulled his cables through an old drain pipe, and lo! the tile manufacturers commenced flooding the country with vitrified pipe ducts of all descriptions. Some time in the early 80's the H. B. Camp Company placed on the market a peculiarly formed clay pipe. It was about 4 feet long and 10 inches square, hence in the vernacular it became known as a “*ten by ten.*” A partition running through the center of this clay box causes each piece to supply two rectangular holes about 4 ins. × 9 ins. inside. This form is shown at *A*, Fig. 9. The early conduits constructed of this material were made by carefully leveling the bottom of the proper street excavation and placing successive lengths of tile thereon. The joints between the several pieces were made by wrapping



*Fig. 8. Laying Cement Pipe Conduits.*

several layers of jute or burlap, previously dipped in hot asphalt, around the ends to be joined, and then painting the last wrap with a liberal coat of the melted hydrocarbon. This form of conduit was intended to carry three cables in each division of each piece, and there are many thousand feet that after more than a decade of severe service are doing good work, and seem likely to remain serviceable for a generation to come.

Experience developed two faults: It was found difficult to withdraw cables without injury when as many as three were

allowed to remain exposed to the impacting influence of the dust and dirt that creep into the best subway, and

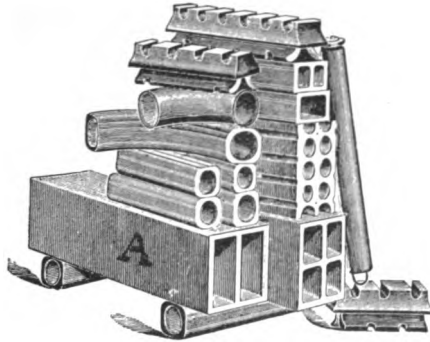

Fig. 9. "Ten by Ten."

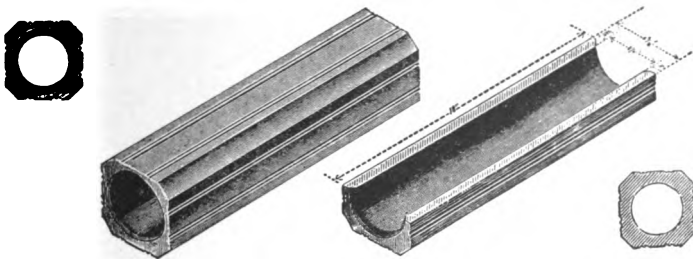

Fig. 10. Hollow-brick Ducts.

duct material laid with no foundation was prone to settle and fall a prey to the predatory pick. With a 10 in.  $\times$  10

in., the latter difficulty was easily cured by placing the duct material on a good 3-in. foundation of concrete, supplying the sides and top with a similar protection, supplemented with a strong piece of 1½-in. plank, but the difficulty of withdrawing the cables was not so easily cured. To meet this objection the Camp Company produced the "hollow brick." This form is illustrated in Fig. 10. It consists of a vitrified clay pipe, essentially



Fig. 11. Mandrel for Hollow Brick.

square in external section, with the corners chamfered, having a round hole about 3¼ ins. in diameter extending through it. Each piece is about 18 ins. long, 4¼ ins. in outside diameter. A subway of any desired magnitude is

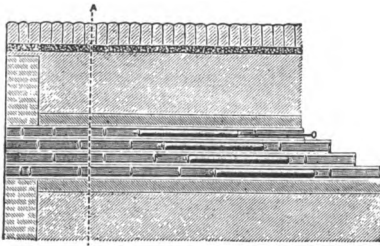

Fig. 12. Showing Use of Mandrel.

easily built by laying up, brick-wall fashion, on the proper concrete foundation, the desired number of hollow bricks to gain the required number of ducts. As each piece is laid it is covered with cement mortar and carefully

tamped with a trowel to a proper bed, in exactly the same fashion as brick masonry. As the ends of successive pieces form butt joints, a wooden mandrel, closely fitting the pipe hole and long enough to cover at least three

joints, is placed in each line of duct and pulled along as fast as successive pieces are placed. This mandrel is shown in Fig. 11, and the method of using it in Fig. 12. At one end a ring enables the mason, who is supplied with a long hook, to grasp and pull the mandrel along, while at the rear a leather or rubber disk that tightly fits the bore of the pipe scrapes away in its passage any superfluous mortar that may have entered through the joints.

In Fig. 13 a partially completed line of hollow brick conduit is shown. The trench is carefully leveled and supplied with the necessary three inches of concrete foundation. Then the hollow brick is piled up, the alignment being secured by a chalk line stretched through the center. As fast as successive pieces of tile are placed, the mandrels are pulled along, the rings of which will be noticed protruding from the ends of the ducts.

In Fig. 14 a finished conduit is shown, with the full concrete encasement ready for the refillment and repavement of the street. The Camp hollow brick was a very distinct and very long stride in the art of duct material making, for it provided something that was indestructible, so far as the decomposing action of street soils was concerned, secured all of the advantages of the single duct space, was able to accommodate itself to subways of any desired magnitude, possessed sufficient flexibility so that curves could be turned with ease, and intrinsically was a thoroughly good insulator; while the interior was smoother and easier on the cable than any other form except the soft and greasy surfaces of creosoted wood. The hollow brick, however, labors under the disadvantage that it is impossible, without going to the most extraordinary

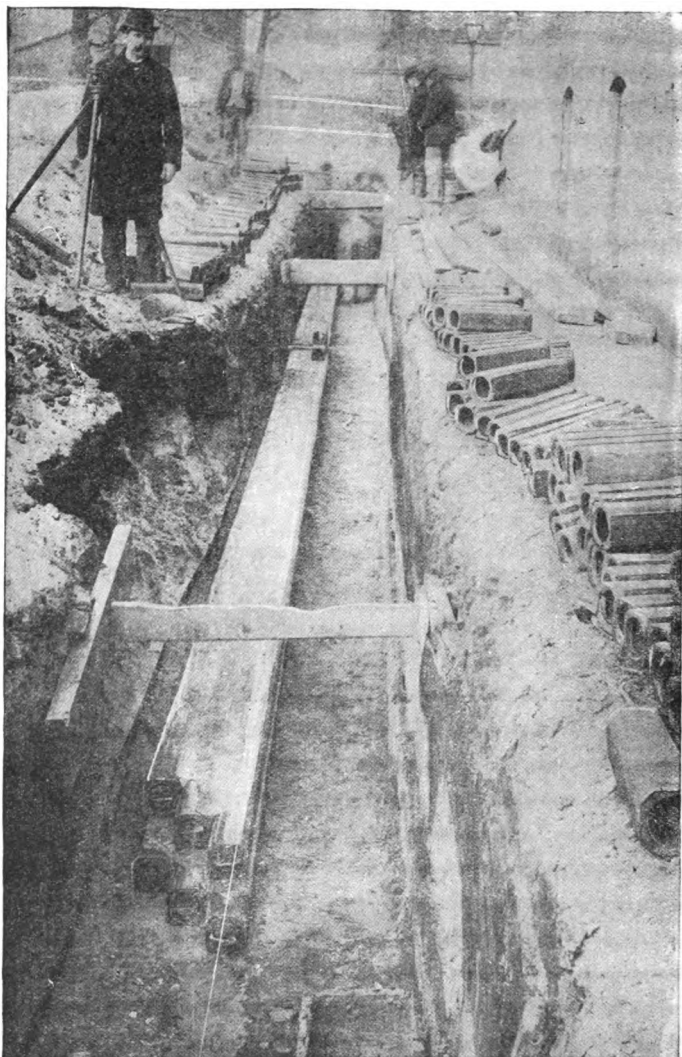
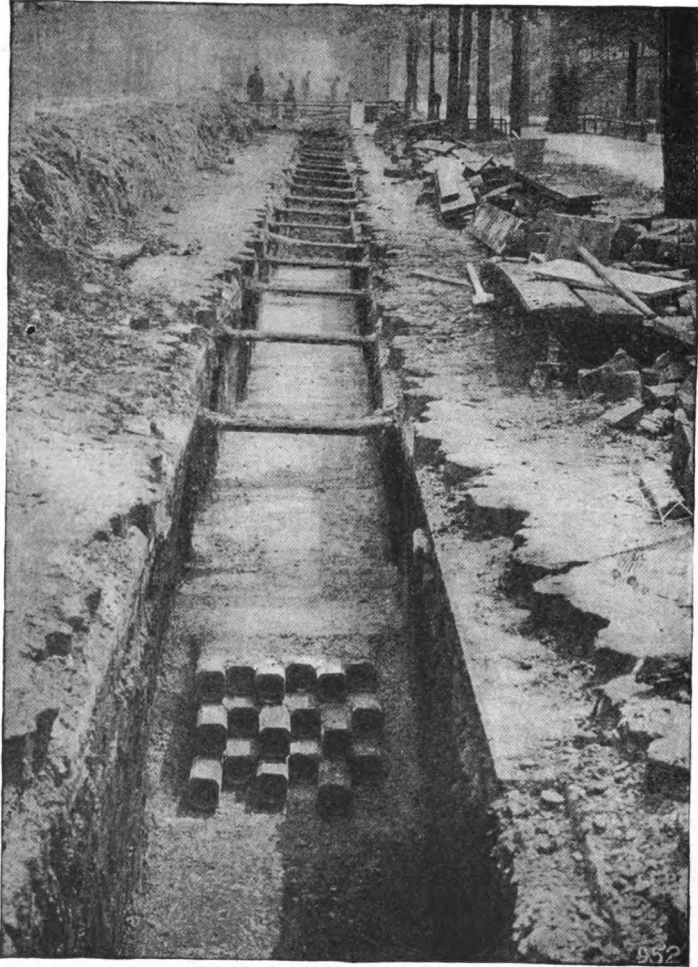

*Fig. 13. Partially Complete Hollow-brick Conduit, Showing Mandrels.*

labor and expense, to build a conduit that is even remotely moisture- and gas-proof, and as it needs the use of a trowel in laying, trade unions have declared that only skilled masons shall be employed, thus saddling those who use this duct material with either the payment of union rates of wages, or the prospect of a strike, and a fight against the arbitrary tyranny that American trade unions always endeavor to inflict. Being laid in 18-in. lengths great flexibility is secured, handling is easy and rapid, and it is claimed breakage is reduced to a minimum. Contrariwise, where conduits of a considerable number of ducts are to be installed, the labor in handling so many small pieces becomes excessive. With these manifest advantages, it is not surprising that hollow brick promptly captured and has held the bulk of subway construction for a number of years, and that many millions of duct feet have been placed and are now in operation.

The desirability of some form of duct material which could simultaneously preserve all the advantages of the hollow brick, minimize handling and obviate the necessity of skilled labor, was early recognized, and the clay men atavistically returning to the old "10 x 10" idea tried to make clay shapes of long lengths containing several cable spaces; hence the so-called "Multiple Duct," of which the McRoy Clay Works were the pioneer exponents. The general type of the McRoy duct and simplest method of laying are shown in Fig. 15. The clay sections are made in lengths of about 5 feet, and contain 2, 4, 6, 8 or more ducts, as the purchaser may desire. Each length is provided with one or more one-half inch holes molded in the clay partitions, into which iron pins forming dowels may

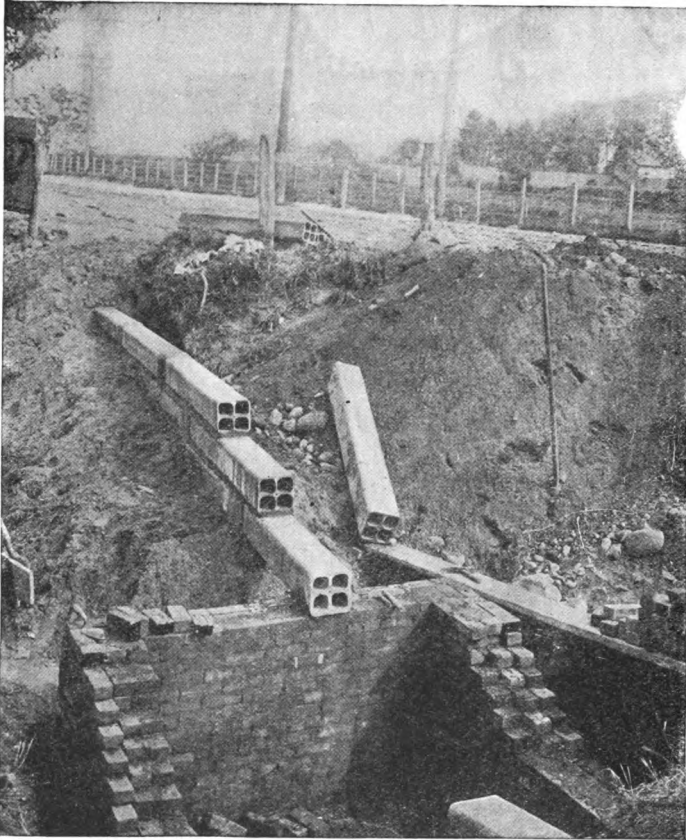



*Fig. 14. Completed Conduit Trench Ready to Refill.*

be fastened, thus causing ducts in succeeding lengths to align with great accuracy. Joints are best made as indicated in Fig. 16, by wrapping tightly about each succeeding piece several layers of asphalted burlap. The simplest and cheapest method of laying is that shown in Fig. 15. The proper trench is excavated, leveled, and the requisite number of multiple sections piled up. To secure bearing, a thin layer of mortar is spread between each tier and the trench refilled. This method is adequate where there is little to be feared from street excavation, but is insufficient in most street work, and the conduit is almost sure subsequently to suffer from settlement. The standard method of building is shown in Fig. 17. After the proper trench is excavated a three-inch concrete foundation is laid, and the sides lined with the cheapest lumber, so spaced as to make a trough six inches wider than is needed to receive the proper number of multiple sections. These are then joined and placed on a concrete bed, leaving three inches on each side between the planking. Just as each piece is placed a coating of thin mortar is applied to the clay surfaces in contact with each other. When all the duct material is in place the side spaces are tamped full of concrete, and a three-inch cover of the same material completes the work. In some instances the cheaper plan of using a lumber foundation has been adopted, as shown in Fig. 18, which is mentioned only to be avoided. Lumber in such a situation will sooner or later surely rot and allow the conduit to settle, thus ruining what would otherwise be a first-class piece of work.

In Fig. 19 an example is given of the McRoy ducts and



*Fig. 15. Multiple Duct.*

cement-lined pipe comfortably and amicably occupying the same trench, utterly oblivious of the probable rivalry of their respective manufacturers, while in Fig. 20 the practical, perfect flexibility of the multiple duct is shown in the ease with which a curve may be constructed.

The manufacture of multiple duct conduits struggled for a long time with indifferent success, as with every additional duct the difficulty both of molding the sections and of burning them without excessive wastage due to unequal shrinkage becomes very great, but with sufficient ap-

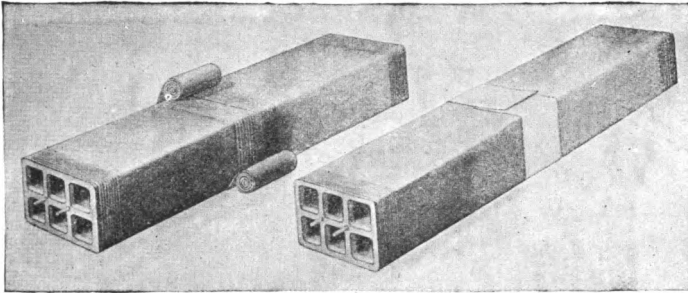

*Fig. 16. Making Joints on Multiple Duct Conduit.*

plication of American perseverance these troubles were gradually surmounted, and following the lead of the McRoy Company many other tile manufacturers entered the conduit field until at present there are a number of firms, among which the engineer has ample opportunity for a wide selection.

Each of the various manufacturers offers a product which differs usually in unimportant details from that of all others. Each maker claims some particular merit for little wrinkles which distinguish his output from that of

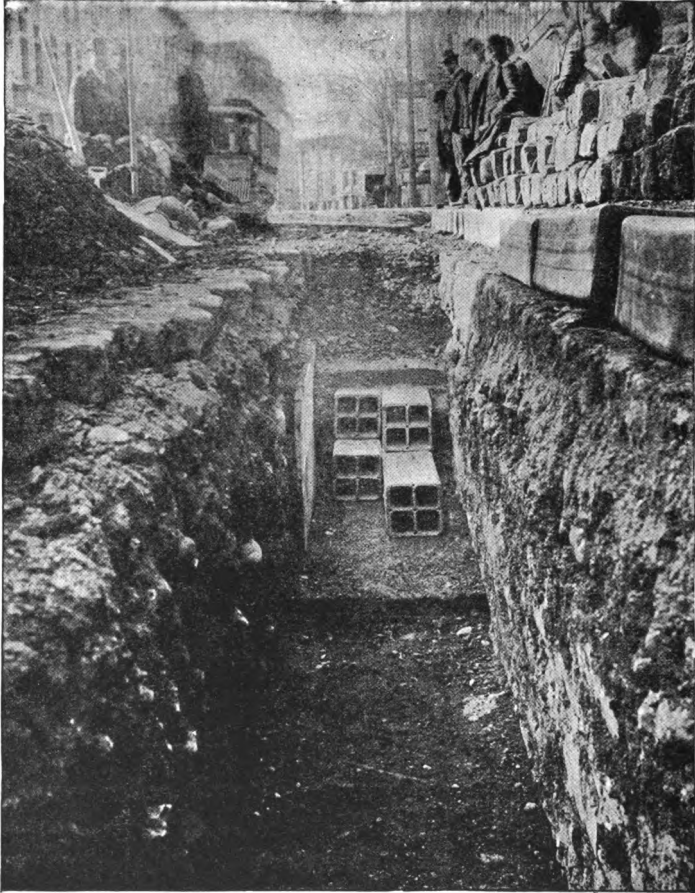

*Fig. 17. Multiple Duct Conduit.*

others. A single example will, however, suffice to illustrate the forms of duct material from which the engineer is now able to select, and the line of duct material offered by the American Vitrified Conduit Company is large, di-

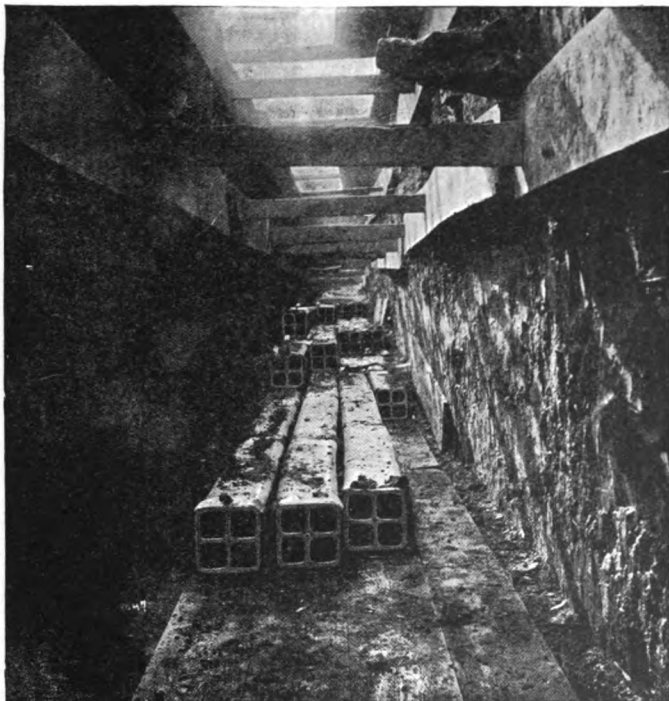

*Fig. 18. Multiple Duct Conduit with Timber Foundation.*

versified, excellent, and thoroughly representative of the best present practice in the manufacture of duct material. The various single-duct forms now put upon the market by this company are illustrated by Fig. 21. A slight an-

alysis will reduce these to four types: The square form, in which each piece is a true rectangular parallelepipedon having full corners so that it may be laid up in a solid wall exactly after the fashion of brick work. At the other extreme is the cylindrical duct or pipe which precisely resembles an ordinary drain pipe minus the bell.

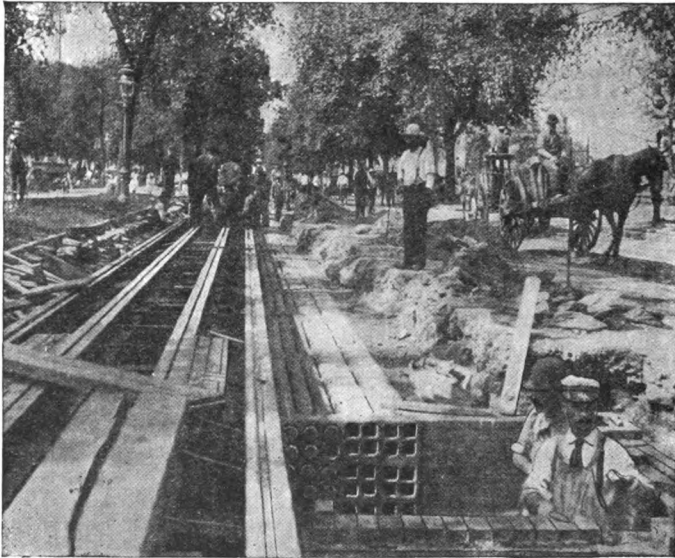

*Fig. 19. Cement Pipe and Ducts.*

Intermediate between these two is a hexagonal duct and a form with fluted or semi-circular corners. These respective types are marked *A*, *B*, *C*, and *D* in Fig. 21.

The square duct presents the advantages of requiring a minimum expenditure of mortar in the construction of the subway, while the smooth surface requires this shape

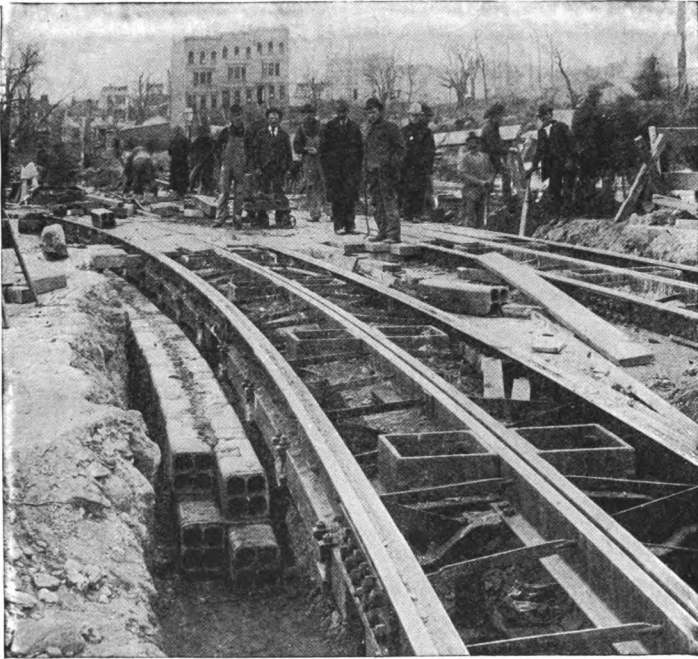

*Fig. 20. Multiple Duct Curve.*

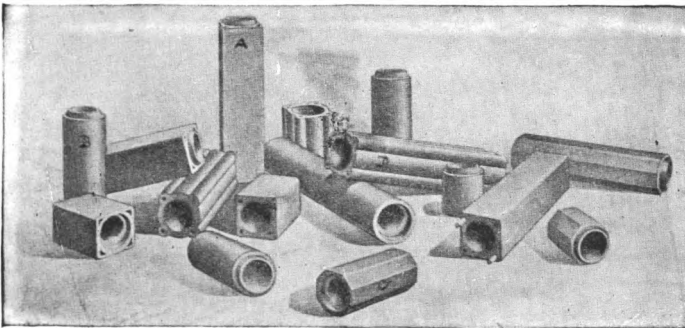

*Fig. 21. Types of Single-duct Cond-it.*



to depend for solidity on the actual adhesion of the mortar to the exterior of the vitrified clay. In the case of the round pipe, a maximum amount of concrete or mortar must be employed in order to fill all the voids between different ducts. Here again solidity depends upon actual adhesion, but with the round pipe, each duct lies in a matrix of concrete, in precisely the same man-

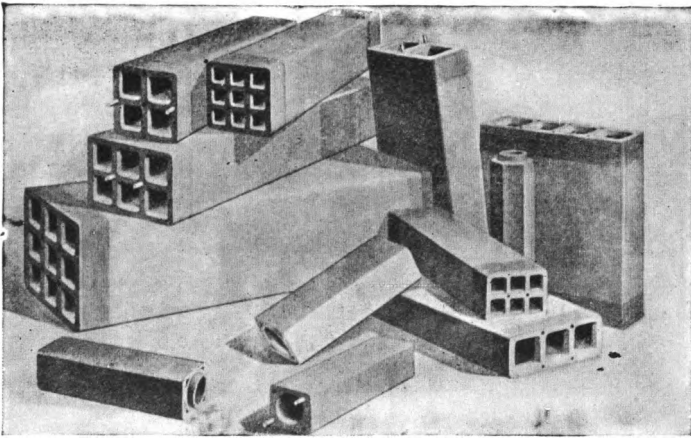

*Fig. 22. Some Multiple Duct Forms.*

ner as with wrought-iron pipe or cement-lined pipe ducts. The hexagonal form offers a compromise between the round pipe and the square brick, while the fluted pipe is designed to secure a maximum strength by allowing the cementing material to embed itself in the corrugations molded upon the sides. The American Vitrified Company score good points in supplying their single duct material with socket joints, so that the successive lengths may fit into each other, thus securing a much better joint

than can ever be obtained with simply butted ends. Each piece of the square type is provided with a dowel-pin hole in each corner, so, if desired, four dowels may be used at each joint, thus insuring the best possible centering of every piece.

Fig. 22 illustrates the general design of multiple duct forms which may be obtained with any number of cable spaces from 2 to 16, and with this wide selection, it must be a very exacting designer who cannot pick such a form of duct material as will best suit the particular needs of the work in hand. In Fig. 23 the latest form of so-called "Round-hole Mul-

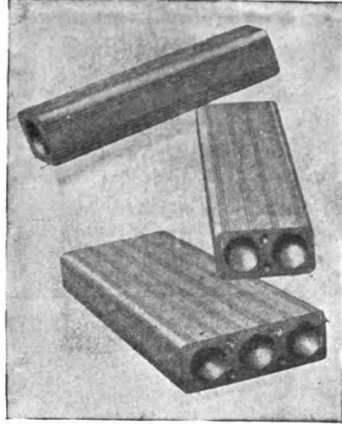

Fig. 23. Round-hole Multiple Ducts.

tiple Duct" is shown. This type is a kind of compromise between the hollow brick and the regular multiple duct system.

Table No. III. (see page 38) recites the general sizes of the various forms of duct material thus obtainable.

In Fig. 24 a series of diagrams are given, showing in detail the way in which multiple ducts of various capacities may be grouped in order to obtain a subway of any desired number of ducts from 2 to 72. These diagrams are based upon the use of a 4-in. concrete foundation for the conduit, with a 3-in. cover, but with no concrete upon the sides. The bottom foundation is essential to life and

durability. The top cover is of use to prevent injury to the conduit from careless street excavations, and is only desirable for this purpose. The concrete at the sides serves a similar purpose only, and both the sides and top may be omitted if the economy thus obtained is considered equal to the risks incurred of injury to the subway, but there is no question that the complete concrete encasement gives the strongest, most substantial and securest structure, and is, by the best opinion, considered fully worth its cost.

TABLE No. III.

*Conduit Sizes.*

TYPE OF CONDUIT.	SIZE OF END SECTION IN INCHES.	STANDARD LENGTHS IN INCHES.	SPECIAL SHORT LENGTHS IN INCHES.	APPROXIMATE WEIGHT PER FOOT.
Three-inch ducts :				Lbs.
Single dowel . . . . .	$4\frac{1}{2} \times 4\frac{1}{2}$	18	6, 12	10
Square, self-centering,	$5 \times 5$	18	6, 12	14
Round, self-centering,	$4\frac{7}{8}$ dia.	18	6, 12	10
Octagon, self-centering,	$4\frac{1}{2}$ dia.	18	6, 12	10
Two-duct . . . . .	$4\frac{3}{4} \times 8\frac{3}{4}$	24	6, 12	$8\frac{3}{4}$
Three-duct . . . . .	$4\frac{3}{4} \times 13$	24	6, 12	$8\frac{1}{2}$
Four-duct . . . . .	$4\frac{3}{4} \times 8\frac{3}{4}$	36, 48, 72	6, 9, 12	8
Four-duct . . . . .	$4\frac{3}{4} \times 17$	24	6, 12	8
Six-duct . . . . .	$8\frac{3}{4} \times 13$	36, 48, 72	6, 9, 12	8
Nine-duct . . . . .	$13 \times 13$	36	6, 9, 12	$7\frac{1}{2}$
Twelve-duct . . . . .	$13 \times 17$	30	6, 9, 12	$7\frac{1}{4}$
Sixteen . . . . .	$17 \times 17$	30	6, 9, 12	$7\frac{1}{4}$
Two-inch ducts :				
Six-duct . . . . .	$6 \times 9$	36	. . .	$4\frac{1}{2}$
Nine-duct . . . . .	$6 \times 9$	36	. . .	$4\frac{1}{4}$

The method of laying both the single and multiple ducts has been already so fully described, that it is only necessary to refer to Fig. 25, showing the construction

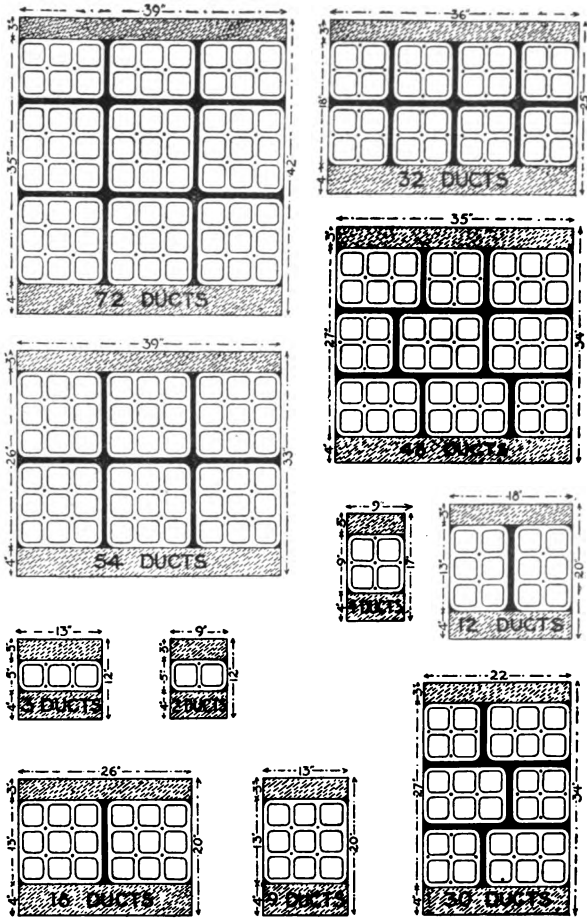
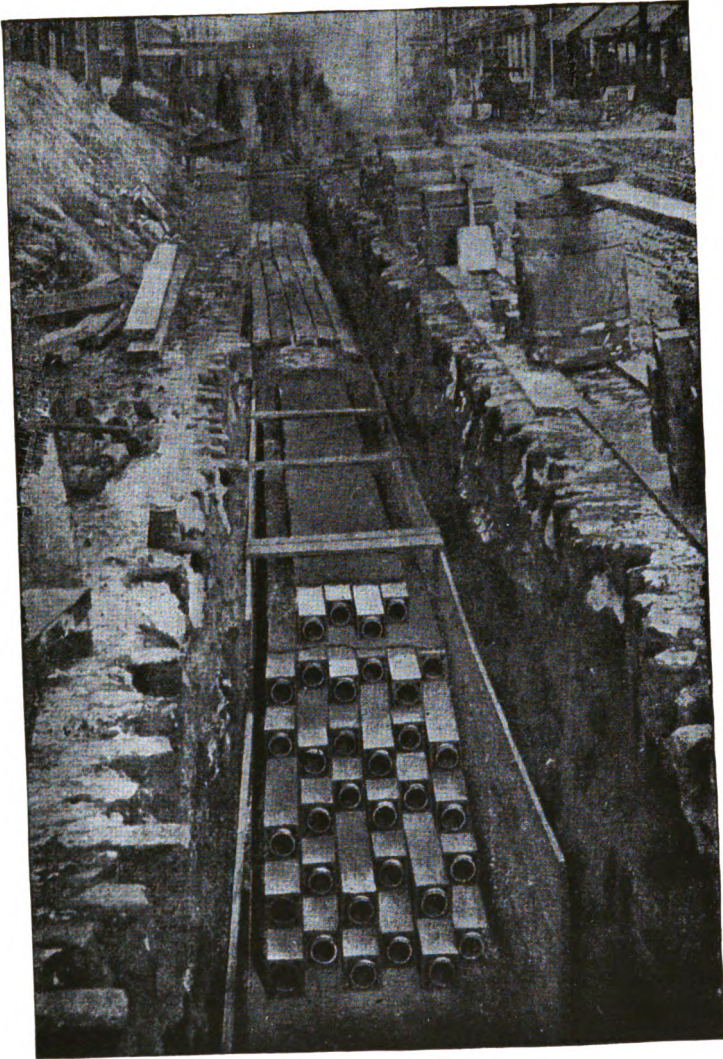

Fig. 24. Groupings of Multiple Ducts.

of a 34-duct subway of single-duct material, and Fig. 26, the construction of a 48-duct subway using four 9-duct sections and two 6-duct sections. In both cases the duct material is placed upon its concrete foundation, the trench is sheeted with timber, allowing three inches on each side for the concrete encasement. In Fig. 25 the cheapest form of lumber is used, which is often allowed to remain in the trench, as costing less to leave than to remove it, while in Fig. 26 the timber walls are made of heavy planking so arranged as to form a mold around each section of conduit, remaining in place only until the concrete is tamped and set, and then being pulled along to serve for the next succeeding section.

The most recent suggestion for duct material is that embodied in the use of wood pulp or paper in the construction of a tube which forms the desired "hole in the street." From time to time the use of some form of fiber has been presented for the purpose, but it is only recently that an asphalted-paper pipe has been perfected sufficiently to make a commercial article. The Electrolysis Proof Conduit Company is placing before the electrical engineer a tube composed of paper pulp saturated with asphalt, tightly rolled and thoroughly compressed so as to form an exceedingly durable and valuable structure. It is made in lengths of ten feet or more, provided with male and female ends, the joints being completed by dipping each length as it is laid in hot asphalt and driving it home upon the preceding piece. The method of constructing the subway with this form of duct material is exactly the same as that employed for cement-lined pipe. Fig. 27 shows the construction of a



*Fig. 25. Subway of 34-Single-ducts.*

7-duct conduit, built of electrolysis-proof ducts as installed in Salt Lake City, and is so self-explanatory as to need no further comment. It is claimed that this form of duct material possesses the advantages of being indestructible underground, of extreme lightness, and, therefore, cheap and rapid in construction; entirely water-proof and

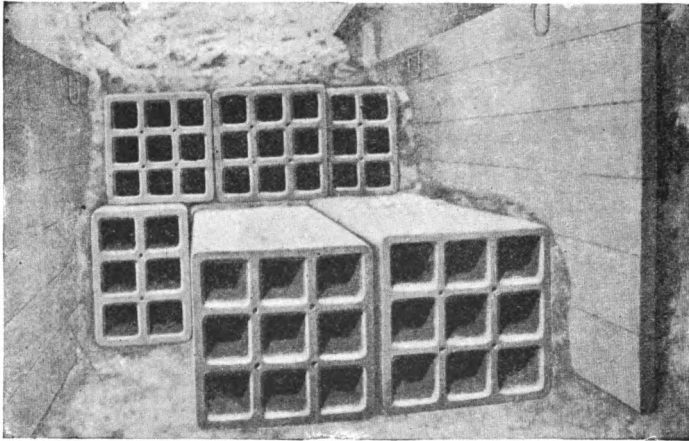

*Fig. 26. Multiple Ducts.*

of good insulating properties. It would certainly appear that paper pulp, thoroughly saturated with asphalt, would be practically rot-proof, but as this assertion has not yet received the actual test of time, a final verdict must be reserved until this opinion has received the conclusive test of experience. Of its lightness there can be no question, as the duct material weighs about two pounds per linear foot, and for this reason, freighting, cartage and handling are decidedly easier than is the case with

any other forms. As the paper tube is very tough, there is no reason for breakage — an item of some moment in the vitrified clay forms. Also the paper tube can be



*Fig. 27. Electrolysis-proof Conduit.*

readily cut to any desired length with a saw, and the proper socket reamed upon the fresh end with an adequate tool. In all these respects the electrolysis-proof conduit



presents distinct advantages. A strong claim for the use of this form is that its high insulating qualities will render the cables immune from parasitic electric currents, and thus, as its name indicates, relieve the telephone engineer from the street railway current bugbear that is supposed to menace cable sheaths. That this duct material has high insulating properties there can be no doubt, as it is abundantly substantiated by the tests which its manufacturers quote, showing that it has successfully withstood 40,000 to 50,000 volts.

It would certainly be highly desirable, if practical, to obtain a conduit which would be a perfect insulator, and so protect the cable from any possible exposure to electrolytic action, but to accomplish this it is not only necessary that the duct should be a perfect insulator, but also that all manholes, distributing boxes, cable terminals and other parts of the subway must have equally high resistances, for if any point fails to protect, the system breaks down. Also the entire structure must be absolutely moisture-proof, or otherwise, no matter how good an insulator the material, it will sooner or later become coated with a moisture film and its insulating qualities, so far as the cable sheaths are concerned, destroyed. Such an ideal subway has never appeared, and the task of installing one is too herculean to tempt most telephone engineers, so in the absence of moisture-proof manholes and other auxiliaries, the specific resistance of the duct material is a matter of small moment.

## CHAPTER IV.

**MANHOLES.**

To permit the introduction, removal and rearrangement of cables, it is necessary to provide access to the ducts at frequent intervals. This is accomplished by building beneath the street surface chambers, into which the ducts open, of sufficient capacity to permit workmen to perform the necessary avocation of cutting and splicing cables. Such working spaces are termed "*manholes*" or "*vaults*." As city conduit systems must follow routes of prevailing streets, which are usually chiefly rectangular to each other, it is necessary to have access to the ducts at such points as fall at the intersection of diverging runs of ducts in order that profitable connections to branching lines of cable may be made.

The frequency of these intersecting points will depend partly on the design of the underground system, but chiefly on the topography of the city; the arrangement and length of its blocks, etc. Measuring distances between street centers in a number of representative cities, it is found that there is a general rough attempt to sub-divide into certain aliquot parts of a mile. Thus, in the Western cities it is common to find 4, 8, 12 and 16 blocks to the mile, or, approximately, 1,320, 660, 440 and

330 feet between street centers. In the East, a decimal sub-division is more prevalent, or 5, 10 and 20 blocks per mile, giving 1,050, 580 and 260 feet between street centers. In no city are uniform block sub-divisions universal, so that in any definite conduit plan the arrangement for the town must be worked out for itself. But, usually, in the central portions of cities it is reasonable to calculate upon placing a manhole, from topographical considerations, as often as every 350 feet, while on the outskirts one every 500 feet will suffice. It is not safe to expect that this allowance will be sufficient for an extensive system, for usually many additional manholes will be needed to reach distributing points, to permit of changing alignment due to street obstacles—so a margin of 10 per cent for such purposes is necessary.

From a manufacturing standpoint, it is at present impractical to obtain continuous pieces of telephone cable more than 1,000 feet in length, for when longer sections are attempted transportation becomes impractical, as the inner layers on the reel are crushed by the weight and tension of superincumbent ones. The cost of handling and the difficulty of drawing in and out a long piece, the risk of accident and injury to the sheath, increase with great rapidity, and a point is soon reached when it is cheaper to build a manhole and make a splice. This is particularly true in view of the rapidly increasing size of telephone cables. Hence from a cable standpoint, experience indicates that it is desirable to place manholes as often as every 500 feet. This distance may sometimes be profitably exceeded, but on the whole, it appears to be about the average economic limit; and thus in the out-

skirts of cities, geographical and structural limitations for manhole distances coincide at from 500 to 600 feet, while in the more densely populated centers, topographical considerations prevail, reducing manhole centers to from 250 to 300 feet.

The *raison d'être* of the manhole is, to give working

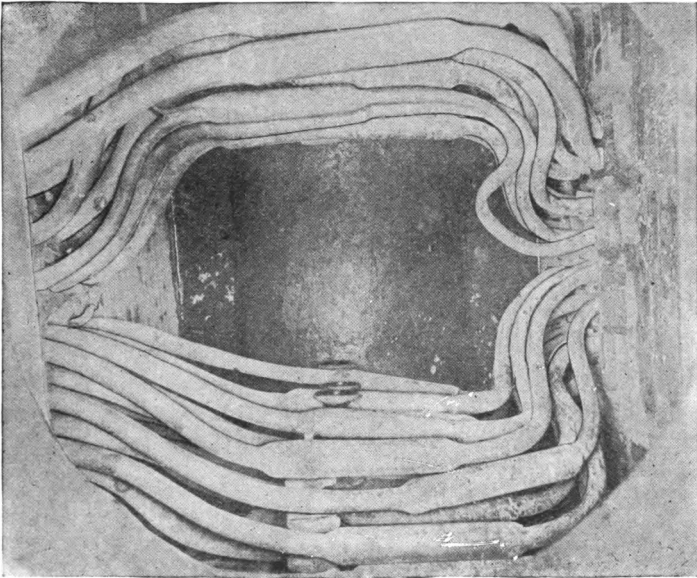

Fig. 28. Manhole Interior.

room around the cables, and this for economy's sake should be of the smallest dimensions compatible with reasonable working space. Yet the error of building too small manholes is a frequent one, resulting in the condition of affairs as exhibited in Fig. 28. Under such circumstances,

the work of cable changing becomes slow, difficult, and expensive, to say nothing of the exposure and injury to which the whole mass of cables is subjected. The only cure is to tear out and enlarge the manhole, a much more difficult and expensive process than to construct it originally of reasonable dimensions. Necessarily the vault

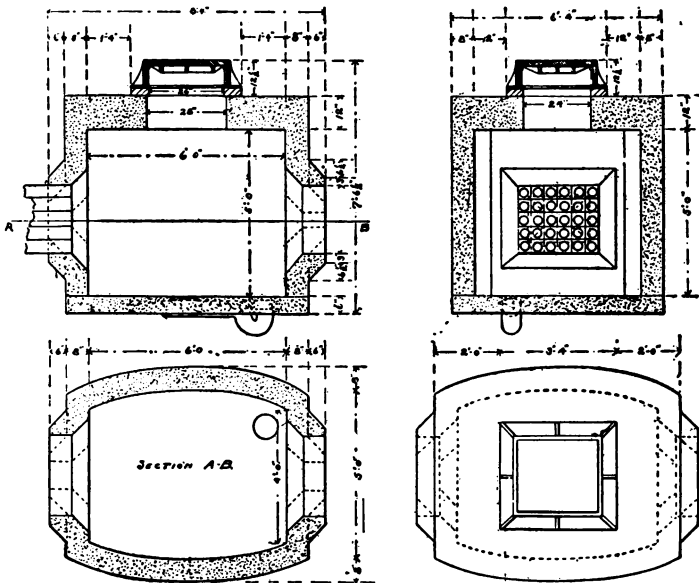

Fig. 29. Standard Manhole.

design must be amply strong to support all superincumbent street traffic, and in addition should meet, as far as practicable, the generally desirable qualities of duct material — indestructibility from both decay and malicious interference, moisture-proofness and gas-proofness, and

high insulation. Experience is gradually reducing man-hole design to what might be termed a "*Standard Type*," an approximately rectangular chamber of either brick or concrete about 4 feet wide by 6 feet long on the ground plan, having about 5 feet head room as shown in Fig. 29. Usually the bottom consists of an 8-inch bed of concrete, with a floated coat of cement as a finish. In the floor a first-class sewer trap should be placed, from which a 3-inch drain is extended, connecting to the nearest sewer. The floor should be graded about 1 inch in the foot, so that the viscous street drainage may rapidly pass off and be discharged into the sewer. The side walls and top may either be brick or concrete at pleasure, and are built as sections of circular arcs to avoid sharp bends in the cables. At the duct entrances the masonry is racked away and the lines of ducts are separated to give as much space as possible between cables to secure ease in handling. Many cases will arise where, either due to street obstacles or the demands of an underground system — as, for example, in the arrangement of office manholes containing a large number of cables — it is desirable to depart from the so-called standard type, but each such case must be treated by itself, and special plan prepared.

Structurally two forms of construction are common, the brick and the concrete. The brick manhole is the most expensive to build, presents the least durability and resistance to outside interference; but is a more flexible type, and in some shape or other sufficient for the purpose, can usually be squeezed in between the most exasperating street obstacles. This quality of flexibility enables the manhole to be built of any shape or size, allows the mason

to turn its walls around or about gas pipes, water mains or other obstacles in an astonishing manner. For uniformity's sake, it is desirable, as far as practicable, to adhere to the general dimensions of Fig. 29, yet in contracted locations a much smaller type, as shown in Fig. 30, will, excepting where a large number of cables must be cared for, suffice. For a brick manhole a first-class quality of good, hard sewer brick laid up in cement is all the description necessary.

The concrete manhole is made by preparing a collapsible mold of the size and shape of the interior of the desired vault. After the bottom of the excavation is paved with 8 inches of good concrete, the mold is placed thereon, and concrete rammed about its sides and top between the wooden form and the earth walls of the excavation, thus forming a monolithic chamber of great strength, durability and cheapness. No better or more economical method of construction exists if street obstacles are not too numerous, for it is easy to prepare a segmental mold that will care for one or two gas or water pipes, but beyond this the special mold required for each case makes the concrete prohibitively expensive.

The vault mold may be constructed in a thousand different ways, every ingenious carpenter having one of his own. In general, the form must preserve the desired size and shape, must have sufficient strength to permit of solidly ramming the concrete about its exterior, and of carrying the street traffic until the concrete be thoroughly set, and must be readily collapsible into pieces so small as to be easily removable through the vault cover.

As the roof of all manholes must resist the heaviest

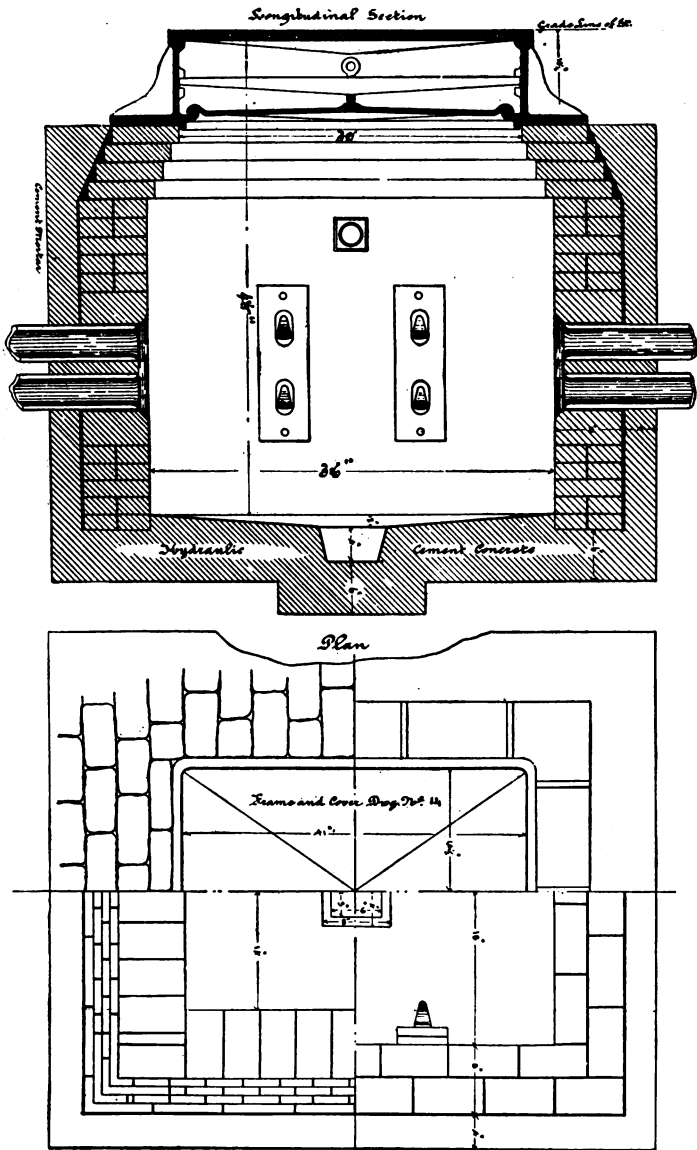
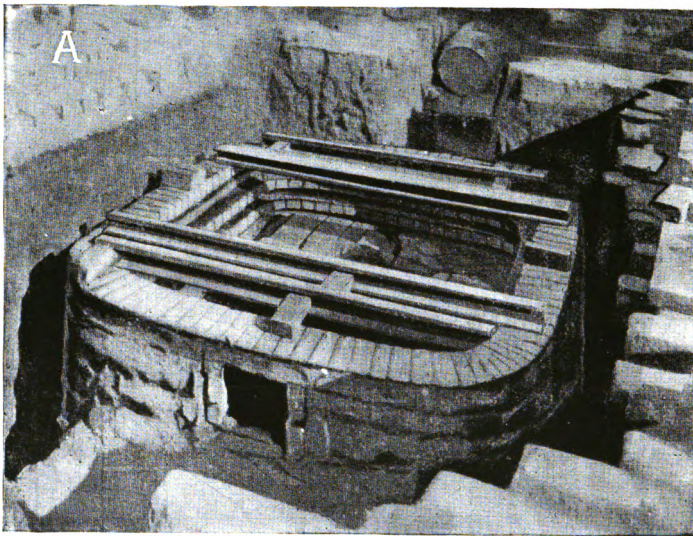

Fig. 30. Typical Brick Manhole.



street traffic, it becomes a structure of some engineering importance, particularly in these days of steam road rollers and boiler trucks. It is probably conservative to assume that a single concentrated wheel load of more than five tons will not be met with, and trucks with such loading do not move at high rates of speed, so small impact allow-



*Fig. 31A. First Course for Rail Roof. Rails In Place.*

ance is sufficient. There are three forms of roof common to brick manholes, and while equally applicable to the concrete type, it is more usual to provide this form of construction with its own molded roof. In the first type the walls of the manhole or roof, at a proper grade, are covered with old rails, tee iron or angles, set back to back, placed about 3 inches apart, the spacing being filled with

brick set on edge, over which a second, or even a third course of brick and iron is placed, depending upon the required strength of the roof. The method of building the rail roof is given in Fig. 31, *A*, *B*, *C*, *D*, and *E*. *A* shows the iron work, *B* indicates the completed first course of masonry, *C* presents the two courses of iron

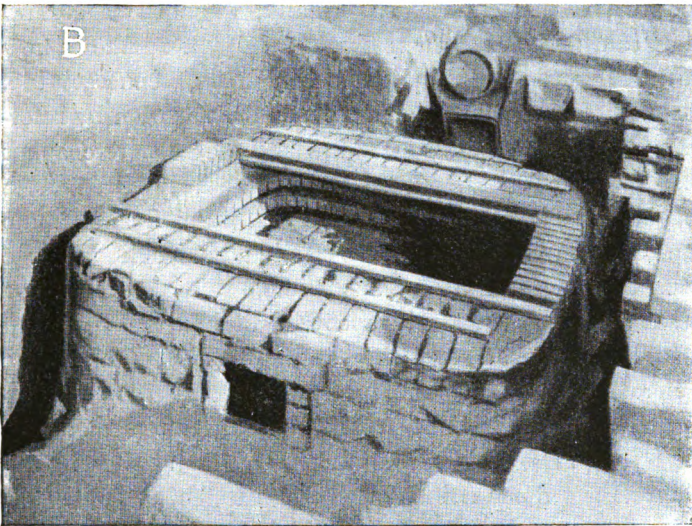

*Fig. 31B. Masonry in Place.*

in place, *D* the masonry partly completed, and *E* the finished top ready for cover.

The more modern type of manhole roof patterns after fireproof building construction, and contains much greater evidence of design. Two or more I-beams or channels of sufficient strength are set across the top of the wall, and brick or tile arches sprung between the beams. Such a

roof is shown in Fig. 32. This plan is much more scientific, and is structurally compulsory where vaults larger than 5 feet by 7 feet top are used, but necessitates a correspondingly greater expenditure. In Fig. 33 a special arch brick is shown, manufactured particularly for man-hole roofs. It is reported that these bricks are safe for a load of ten tons per square foot, and are designed for 32-inch span between beams. Finally, when the necessary time can be allowed for setting, even brick manholes may advantageously be supplied with a molded concrete top. This method is simple and easy, as may be seen by reference to Fig. 29, being merely a sheet of concrete about one foot in thickness. The only mold required is a staging of plank set inside the vault walls, flush with its top, carrying in the center a section of a cylinder or a square of the same diameter as the hole in the cover. Such a staging can be built in a couple of hours, by even an unskilled carpenter, and the vault completed by dumping concrete thereon and ramming solidly into place. By giving the staging sufficient strength to carry the street traffic, pavement may be immediately replaced, and the staging allowed to remain indefinitely until the concrete has gained any desired strength. Such roofs need no metal reinforcement, and have proved entirely satisfactory in so large a number of instances, even under the most trying circumstances, as to be worthy of the widest application.

The designing of vault covers has presented one of the most vexatious of detail problems, and multitudes of devices have arisen — flourished for a time — and disappeared. Almost every conduit builder has his own pet plan. There are two generic types — the “*Tight*” cover

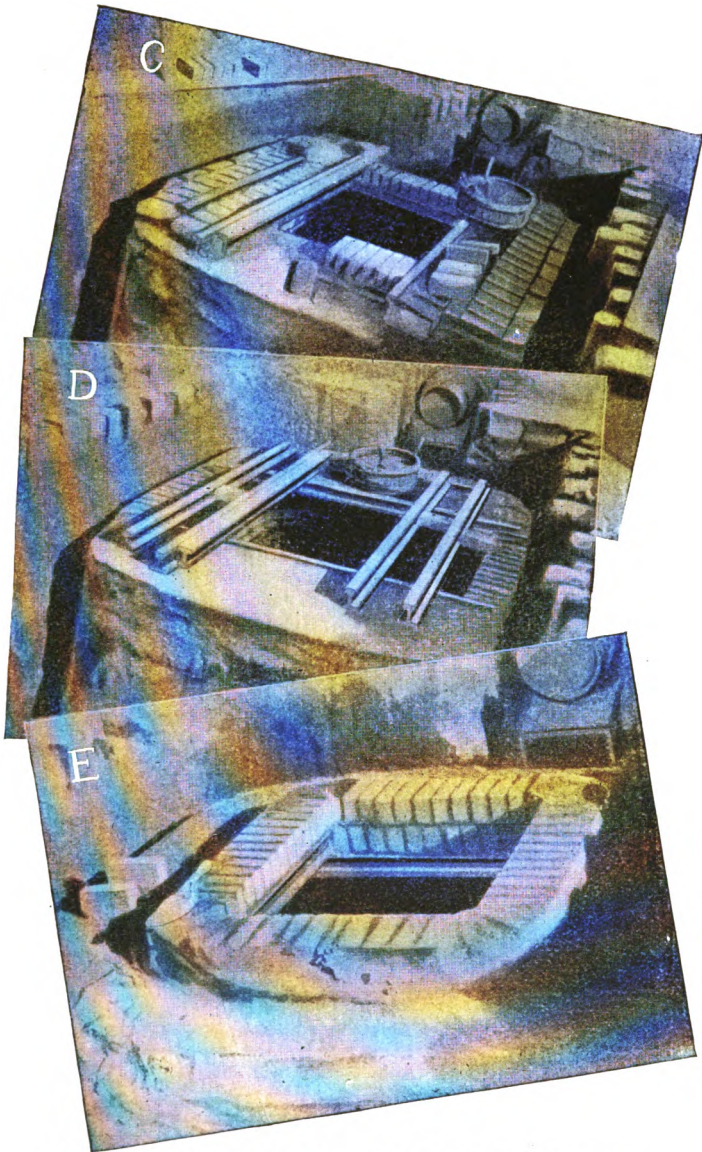

**Fig. 31C, 31D, and 31E. Last Course for Rail Roof. C, Setting Masonry; D, Rails In Place; E, Ready for Cover.**

and the "Open" cover — while morphologically either may be built on the round or square plan. In early conduits the attempt was made to render ducts water and gas tight, and consequently particular stress was given to making the entrances waterproof. To this end covers, usually round, were made double, as shown in Figs. 34, 35, and

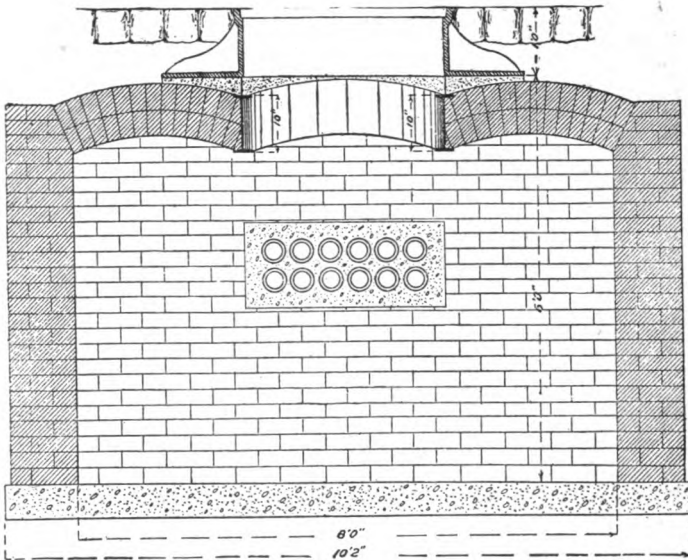

Fig. 32. Manhole with Arched Roof.

36, having an outer lid flush with the street to carry traffic, and an inner or sealing cover pressed against a packing ring or gasket, designed to make the entrance airtight. In Fig. 34 the packing gasket rests in a circular groove in the underside of the inner cover. In Fig. 36 the sealing lid is drawn up against the inside of the cover frame

by four bolts. The design of Fig. 34 is the cheaper to build, easier to manipulate and generally most satisfactory, avoiding exposing the cables to the danger of the inner cover falling against their sheaths. In Fig. 34 reasonable drainage of the spaces between the covers is secured by connecting the groove in the frame around the packing ring with the sewer, but in Fig. 35 no such proviso exists, and this space must be cleaned out by hand each time the vault is opened before the inner lid is dropped.

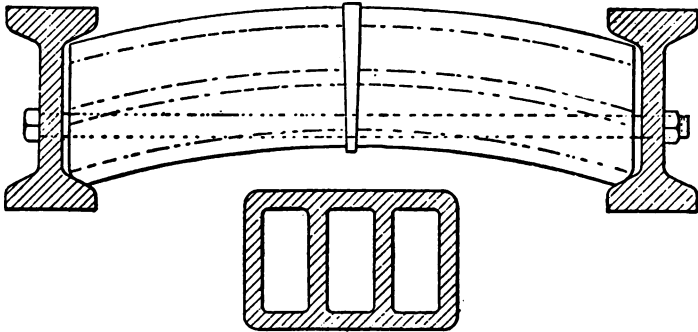

Fig. 33. Special Manhole, Arch Brick.

A very short experience with conduit systems demonstrated the futility of trying to make them water-tight, and designers reacted to the other extreme in the endeavor to secure dryness by thorough ventilation. Accordingly, covers were simplified by entirely omitting the inner lid, and in its place hanging a sheet-iron pan in such a manner as to catch any street drainage, as illustrated in Fig. 37; while the traffic cover was pierced with as many holes to permit ventilation as strength would permit. The most recent experience indicates that even the pan is

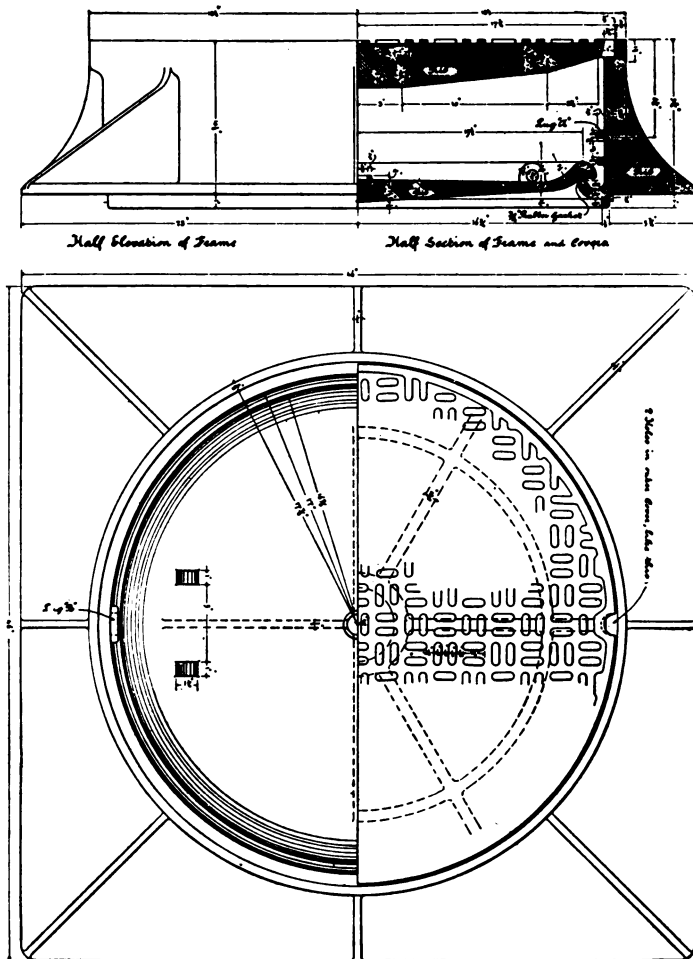
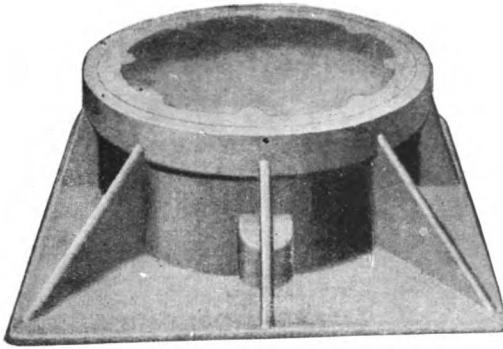

Fig. 34. Circular Tight Manhole Cover, Overhung Inner Cover.

superfluous, and present tendencies are in the direction of an exceedingly plain, strong, simplified cover, as shown in Fig. 38.

The prime requisites in the manhole entrance are resistance to street traffic and accessibility to the vault. The round cover is smaller, consequently can be built lighter, cheaper and easier to handle, but access to the vault is much more restricted, the difficulty and cost of cable



*Fig. 35. Circular Tight Manhole Cover, Underhung Inner Cover.*

pulling increased, while the light, round traffic cover is quite likely to be dislodged by the blows of passing wheels. In the design of Fig. 38 a lock is supplied to secure the cover in place. As a guard against accident, this is valuable, and probably worth both its original investment and its maintenance cost; but as a protection from malicious interference, it is of little moment, as there is no manhole into which a determined party of strikers, easily arming themselves with picks and shovels, could



not quickly effect an entrance, while a small stick of dynamite would open the strongest lock in a moment.

Occasionally circumstances compel the construction of a water-tight manhole, then the same engineering precautions must be observed as in building a cofferdam or other subaqueous work. The plan of Fig. 39 exemplifies a suc

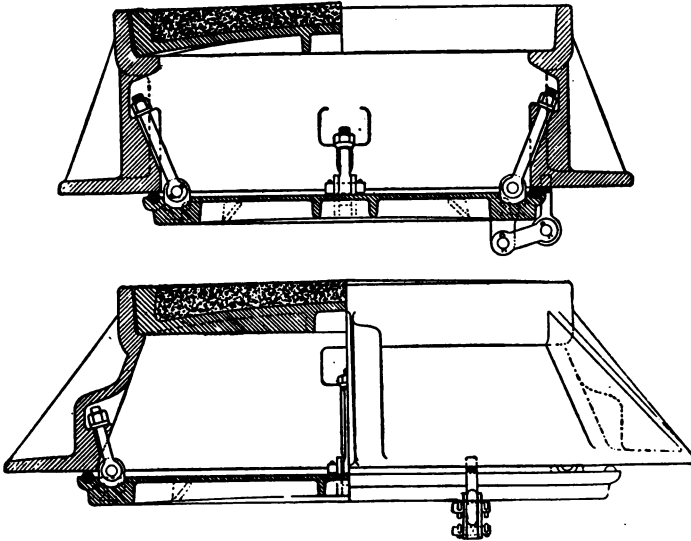
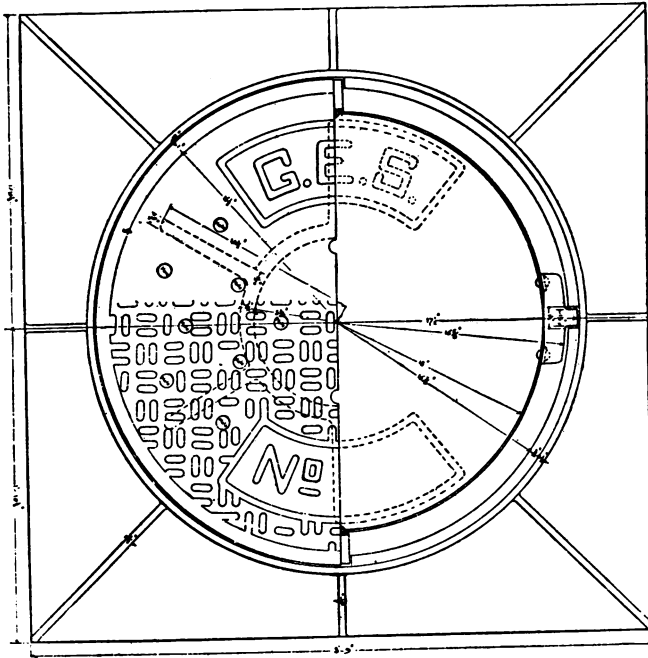

Fig. 36. Baltimore Manhole Frame and Cover.

cessful method. The excavation is completely and carefully sheeted with 3-inch by 6-inch tongue, and grooved matched piling, driven closely together, extending at least 4 feet below the manhole bottom. When the excavation is finished, a double wooden floor of matched tongued and grooved 2-inch plank, the seams in each layer laid diagonally to those in the other, fitted around the sheeting, and



Half Plan of Cover.

Half Plan, cover removed.

Note: Cover to fit snug and true, without rocking.

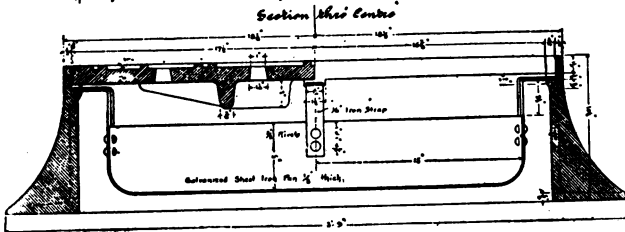
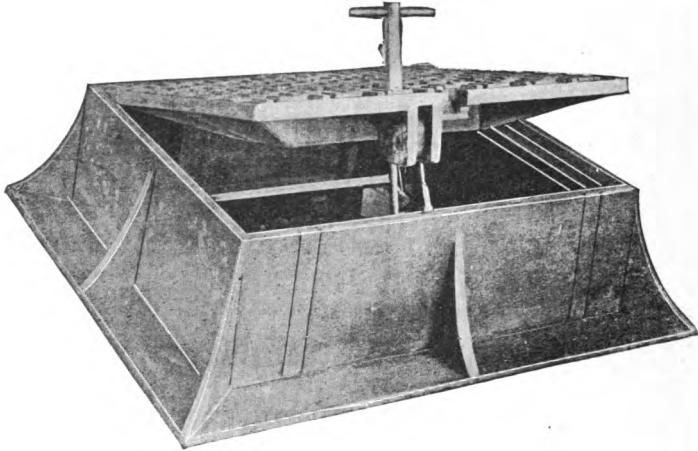

Fig. 37. Open Manhole Cover,

calked into place with tar and oakum, is introduced. On this floor a course of brick masonry 8 inches thick, laid with Flemish bond, is placed about 3 inches inside the sheeting, the intervening spaces being afterwards tamped full of concrete. The chamber thus formed of the wood floor and the brickwork is now lined with at least three layers of the best roofing felt thoroughly asphalted and mopped into place. Six inches of concrete are now



*Fig. 38. Square Manhole Cover.*

deposited upon the bottom, then three more layers of roofing felt applied; next 12 inches of concrete to complete the bottom, on which the interior, and vault walls proper, are built. These should be made of brick masonry 12 inches in thickness, laid up in old English bond. All the mason work must be in neat cement mortar, and all joints thoroughly pointed and calked. In such a manhole,

the entrance of the ducts presents the chief difficulty, as it is next to impossible to carry in any of the clay forms and preserve waterproofness. By using iron pipe on either side, flanging the same to the sheeting with roofing felt gaskets, the entrance may be made water-tight.

#### SMALL MANHOLES.

The design of manholes so far considered has proceeded upon the assumption of providing space beneath the street surface to allow all of the avocations of cable splicing to be performed. In certain localities where conduit systems are not of great magnitude, where street traffic is not excessive, and where great cheapness is desired, a much smaller and cheaper style of vault may be adopted. Such manholes are provided with large rectangular covers, about 36 inches by 24 inches. The cover frame is made of angle iron joined at the corners with knee braces, and the cover itself of a rectangular angle iron frame filled with hard oak plank. This provides a cover of great lightness, cheapness, and of reasonable durability under

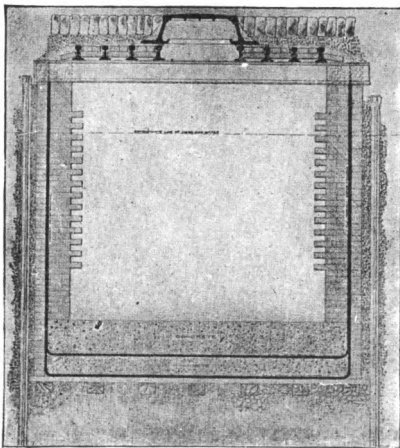

*Fig. 39. Waterproof Manhole.*

lightness, cheapness, and of reasonable durability under

the light street traffic of cities of 40,000 or less population. The manhole itself may preferably be a brick structure, not over 2 feet in depth, and about 4 feet by 3 feet in plan. Vaults of this description may be constructed either of concrete or brick at pleasure, or even built of 2½-inch matched plank. These manholes are too small to permit of cable splicing inside of them, so cables are drawn into place and spliced in the street by allowing a large U-bend to extend out of the manhole entrance. After splicing is completed the cables are dropped into place. Such construction is only permissible where a few small-sized cables are used, but becomes desirable in the smaller cities where the underground systems must be constructed with greatest economy, or in the outskirts of larger towns where the systems are rapidly changing.

## CHAPTER V.

## DISTRIBUTION.

No complete, far-reaching and universal scheme of distribution has been worked out and put into practice. There are now two general methods in use that may be termed "*Aerial*" distribution and "*Block*" distribution. Aerial distribution can further be sub-divided into "Alley lines," "Back-lot lines" and "House-top lines." Aerial distribution, whenever it can be used, is the most satisfactory and cheapest method, but in none of its forms could it be tolerated for a moment in the crowded portions of large cities. In most of the newer Western towns, the blocks are of greater size than those in the East. A narrow passageway or lane is built in the center of each block, on which the rear of the various lots abuts. This is not a thoroughfare in the ordinary sense of the word, although under the control of the city government, as it is rarely wide enough to permit vehicles to pass abreast, but is used for the delivery of goods, removal of garbage, ashes, etc., and an additional source of light and air. It is easy, even in the more thickly settled portions of the largest towns, to obtain permits to erect light aerial lines in such alleys, for the purpose of distribution, particularly if work is so planned that lines do

not cross the larger thoroughfares. The main distributing pole for each run is located inside the alley as near the street line as may be; a manhole is built in the conduit at the street and alley intersection, and from this manhole a lateral duct — preferably of iron pipe — is extended to the distributing pole and carried up alongside of it 10 or 15 feet, so that the cable may be secure from the attacks of street urchins. The general features of this

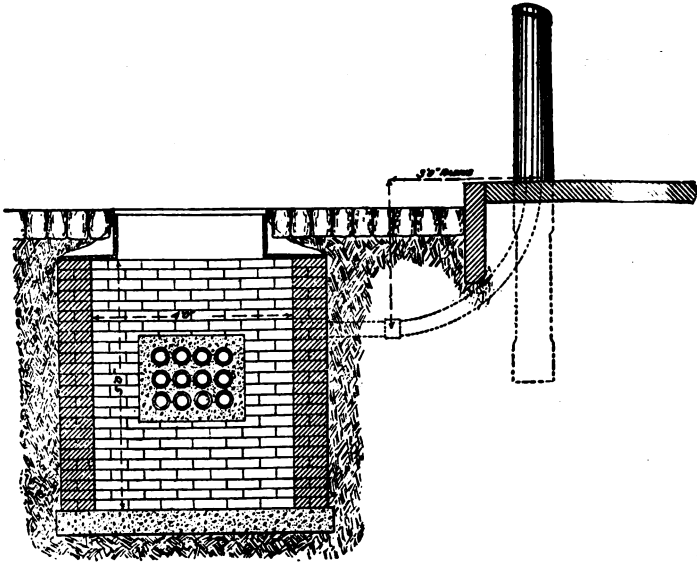
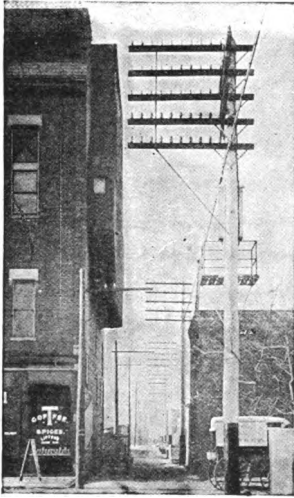

*Fig. 40. Manhole with Lateral Connection.*

method of construction are shown in Fig. 40. The cable to be distributed reaches the alley manhole in one of the main conduit ducts, and is then taken off through the lateral up the pole to a distributing box, and here the cable is fanned out and spliced to bridle wires that

connect it to the open wire lines. The distributing box and general features of this plan are shown in Fig. 41.

Where alleys do not exist, it is often feasible to buy or hire the privilege of erecting a distributing line along the rear and between adjacent lots. Such lines are known as



*Fig. 41. Alley Line for Distribution.*

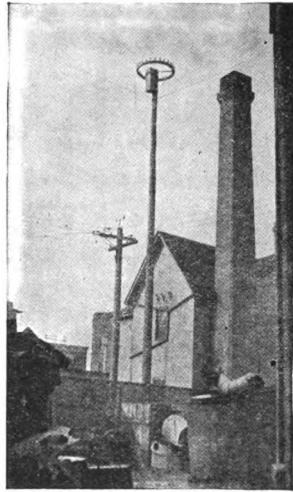

*Fig. 42. Crow's Nest Distributing Pole.*

“Back-lot lines,” but in constructive features differ in nowise from the regular alley line.

In cases where neither alleys exist nor back-lot rights can be obtained, a crow's-nest distributing pole may be used. Ordinarily speaking, two poles will suffice for the entire distributing system of a single block, and it must be a very obstreperous set of property owners who cannot be coaxed, cajoled or hired into granting the necessary rights. The crow's-nest pole is shown in Fig. 42. A sub-



stantial but tall pole is provided, to which, through the proper lateral duct, a cable is conducted from the nearest manhole, and terminated in a distributing box near the pole top. The pole itself is capped by a wooden ring about 5 feet in diameter, carrying insulators spaced about 4-inch centers. From the terminal box bridle wires are carried from the insulators, and from each one a clear span of bare copper — or preferably a twisted pair — is strung to the roof of the subscriber. This is an exceedingly valuable, flexible and cheap method of distribution, particularly where telephonic density is not excessive.

House-top distribution is accomplished by obtaining permission to extend a cable through the usual iron pipe lateral up alongside the wall of a building, usually on the outside, though sometimes through an elevator well or light shaft, to the roof and terminating the cable upon a rack, either of iron or wood. From this rack, lines may be extended from all directions to small fixtures placed upon other housetops. Fortunately, some one of the aerial methods of distribution thus outlined can be employed in all but the most thickly settled portions of the largest cities, and by some one of these methods all those who require but one or two lines to a building or the so-called house-to-house distribution, can be cared for in a cheap and satisfactory manner. Examined critically, however, none of the aerial methods are truly underground distribution, as a whole cable in each case feeds into a pole line or housetop fixture, from which the true distribution in the shape of subscribers' drop wires takes place.

In the central portions of the larger cities, there is not

an extensive demand for single-line distribution. Buildings are not only larger on ground plan, but higher and telephonically more densely populated. It is rare to find a half-dozen of the large modern office buildings to a single block, and the subscribers in each of these may be counted possibly by hundreds. It will pay, therefore, to open the street, put in a manhole, lateral, and run a large cable to a complete cable head in the basement of any such building. Such a system falls at once into the category of block distribution, and is interesting to the

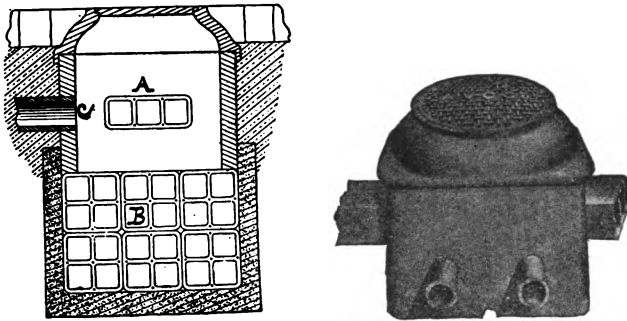

*Figs. 43 and 44. Tile Service Distribution Box with Iron Surface Cover.*

telephone engineer in the comparative ease with which he can fill up a 100-pair or 200-pair cable and gather in a goodly bunch of subscribers. Distribution is best accomplished by placing a distributing manhole at each street corner, with possibly one or two additional ones intervening. For this purpose no better plan is presented than shown in Figs. 43 and 44. The main conduit extends from street to street, as shown at *B*. Superimposed thereon the distributing ducts are placed as indicated at *A*. As

often as may be, a service box, in reality a miniature manhole, is introduced, from which a lateral *C* runs to the building to be reached. The illustrations, by giving both a vertical and perspective view, make this method perfectly plain. Where a small number of sub-stations is to be cared for and a less flexible and cheaper plan will suffice, the method of extending the lateral shown in Figs. 45 and 46 will apply. In Fig. 45 the distributing conduits provide three ducts, and the service box two

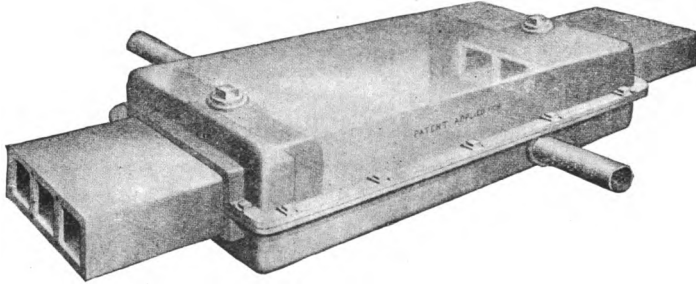
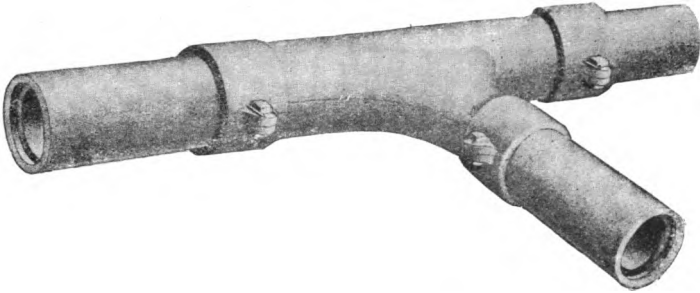

*Fig. 45. Iron Service Box for Three-way Conduit, Two Services.*

branches. On the multiple terminal system, two or three such boxes could be placed in each block, and a pair of 200-pair cables, one for each side of the street, looped successively through each building passed, giving a system of almost perfect flexibility. The only drawback to this plan is the necessity of opening the street whenever access to the distributing box is required. In Fig. 46 the same general idea, but still further simplified to apply to a single cable, is shown.

The only really scientific and complete plan of under-

ground distribution ever carefully worked out and thoroughly put into practice is that devised by Mr. W. J. Johnston, and introduced in the underground system of St. Louis. On the top of the main conduit a peculiarly shaped tile containing four compartments, as indicated in Fig. 47, is placed. This tile has side outlets on either side placed opposite every property-owner along the conduit line. From these outlets, either at the time the conduit is constructed or subsequently, as may be desired,



*Fig. 46. Lateral Connection to Main Duct.*

lateral ducts are extended to and through the curb wall of every building. In the main manhole at every street intersection, the cable to be distributed is potheaded, and "okonite" ends are spliced on, which are drawn through the distributing ducts *A* and *B*. The duct *C* is always reserved for the carrier—a contrivance consisting of two iron hooks attached to a roller, shown in Fig. 48, or wooden shoe of such size as to easily travel through the carrier duct *C*. When introduced into this duct, the iron hooks extend over and reach into the distributing ducts *A* and *B* on either side, and are of such a height as to pass

directly opposite the center of the outlet holes. Normally, the okonite wires lie at the bottom of the ducts *A* and *B*. If a house connection is to be made, the carrier is hauled through the carrier duct *C*; but prior to starting on its journey, an okonite pair is lifted and placed in one of the hooks. As the carrier is drawn along, the hook lifts this okonite pair away from the bottom of the distributing duct and out of proximity to the remainder of the wires. Before the carrier starts, workmen have been placed in the cellar

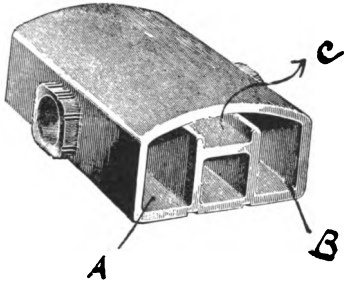

Fig. 47. Johnston Distributing Duct.

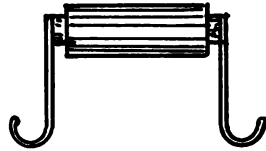

Fig. 48. Carrier for Johnston Duct.

of the building to be connected, have found the end of the lateral duct, the location of which has been carefully recorded, and have passed through this lateral a long wire-grapple into the distributing duct. When the carrier arrives opposite the desired outlet, the grapple can engage with the okonite pair that is thus separated from the other wires, which is easily drawn into the cellar of the building. For elegance in design, complete independence of one subscriber from all others, and the avoidance of frequent street openings, Mr. Johnston's method leaves little to be desired, and is a marked contrast to the makeshift

plans so often adopted of running a cable from a corner manhole to the nearest cellar, and then begging, buying, borrowing or stealing right of way through the premises of the various adjacent owners to reach all other subscribers in the block.

It cannot, however, be denied that the distributing-duct plan is considerably more expensive — at least, so long as the cellar-to-cellar circuits remain unmolested — yet rapidly increasing maintenance due to injury inflicted by predatory rats, mice, and the malicious small boy, coupled with the fact that property-owners are awakening to the idea that telephone owners have been long obtaining a valuable concession for nothing, and are beginning to charge rental for such rights, causes the extra expense of the distributing duct to become significant.

## CHAPTER VI.

**OBSTACLES.**

OF all the problems to be solved by the engineer that of surmounting the obstacles presented by various street structures is the most difficult — not only in the design of a way to place conduits in unreasonably restricted space, but because it is usually very difficult — sometimes impossible — even with the utmost care and skill to foresee the existence of insurmountable barriers until a large portion of the work has been done and considerable expense incurred. Electrical subways are usually among the last of street structures to be introduced, consequently they must content themselves with what space remains after sewer, gas, water, etc., have each appropriated all of the street they could occupy. If the real condition of the sub-soil of city streets was accurately known, a possible location could usually be selected, but as the office of the city engineer is usually a political position, it may be confidently predicted that any information derived therefrom as to location of street obstacles is inherently incorrect and the subway designer can be quite sure that pipes and other impedimenta to conduit location are certainly not where the records show them to be. Wherever else they actually are, is quite another matter, and one which the

telephone engineer must find out for himself as best he may. This state of affairs is perhaps no surprise when such subterranean complications exist as are depicted in Figs. 49 and 50 showing the corner of Harrison and Washington and Market and Washington streets, Chicago, and

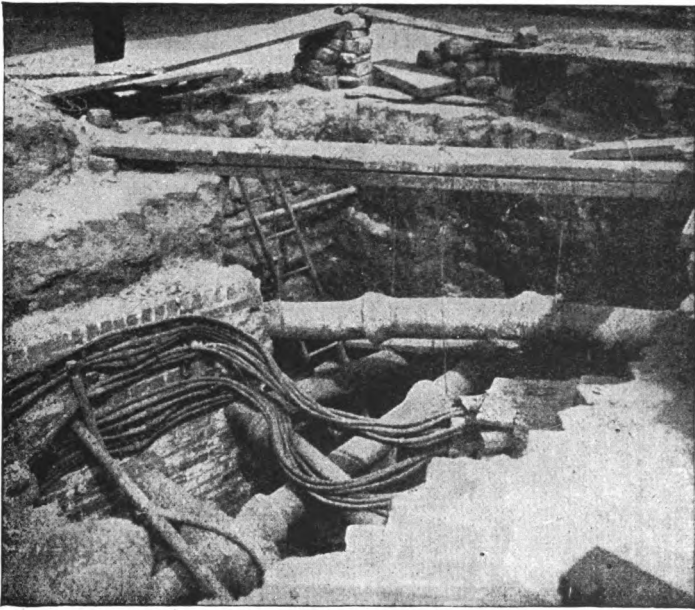

*Fig. 49. Harrison Street and Wabash Avenue, Chicago.*

in Fig. 51 an excavation in Union Square, New York. Still, as no permit to open a city street can be gained save through its Department of Public Works, nor work therein prosecuted excepting in the presence of a city inspector, whose salary is charged against the corporation making



the excavation, it seems strange that accurate records are not kept.

When the construction of a conduit is determined upon, the first step is a careful topographical survey of the proposed location, giving all of the surface features, including street alignment, grades, the location of fire plugs, car tracks, gas and arc lamps, catch basins, drains, etc. This



*Fig. 50. Manhole, Market and Washington Streets, Chicago.*

information will at least give a rough idea of what exists below the pavement, though there is an equal assurance of many additional obstacles. An appeal to the City Hall will now supply a fair idea of what is likely to be encountered, but with no very accurate information as to where it is. Consultation with the other corporations—gas, water, sewer, electric light, telephone and telegraph com-

panies— will yield many illuminating side lights, and with all the information thus gathered, a careful ground plan, together with probable cross sections at each street corner, should be plotted, showing the expected location of existing structures. Thus armed, the engineer may plot a proposed design for his conduit and manholes, and will usually find that almost an ideal one can be obtained.

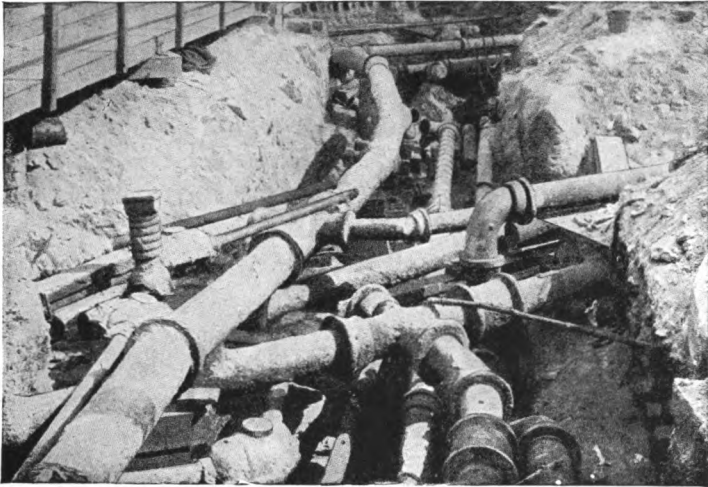

*Fig. 51. A New York Street Corner, Showing Underground Pipe Construction.*

Proceeding to the ground, a series of test holes along the entire proposed location should be dug at every street corner, and, if suspicious circumstances arise, at intermediate points—for a little wasted street trench will pay for many test holes. At each pit, the location of the substructures encountered, both vertically and horizontally from the curb, must be noted. This information enables

the designer to prepare a set of drawings, as shown in Fig. 52, embracing a general ground plan and all test pit sections. Usually this examination will reveal a gas pipe, catch basin, or something else located just a few inches away from its supposed position, and exactly in line with the desired conduit, which must be moved or a new location sought. But once having settled—from test pit information—the position of obstacles, the designer can proceed with a fair sense of security; though even with such precautions cases have arisen within the experience of the writer, when sub-structures so deviated from their rightful course between test pits as to require removal before conduit space could be obtained. Obstacles may sometimes be surmounted by the use of slight curves, either vertical or horizontal, in the conduit, though this is not a practice to be commended. Usually gas, water, and electric light companies are cordial, and willing, on the payment of reasonable expense, to make such slight changes in the location of their property as will enable a conduit to be placed, so that by one expedient and another the engineer must thread his way from corner to corner.

## II.

Few instances in engineering practice illustrate so forcibly the existence of the unexpected as the subway explosions attending the introduction of the first conduits in New York City. Particular pains were taken to make the conduit presumably air tight—constructed of wrought-iron pipe, with threaded joints, equipped with double-covered gasketed manholes, it seemed an impossibility that it

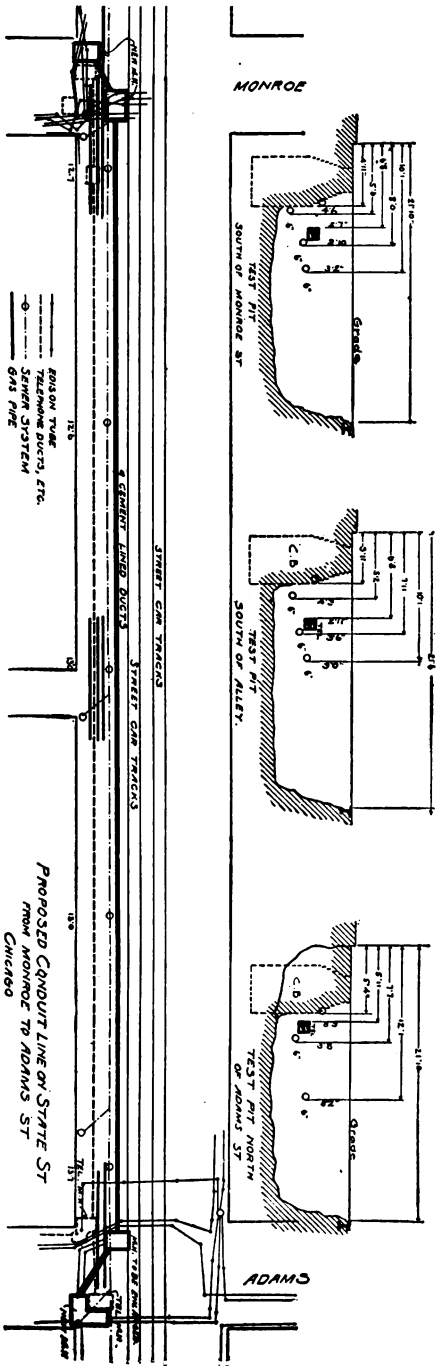

Fig. 52. Test Pits.

should be otherwise than hermetically healed. But a brief period of operation had elapsed before the public was astonished by a series of explosions that took place in the various subway manholes. Investigation showed that owing to the porous character of the cast-iron pipes employed by gas companies, a large proportion of their product leaked away in the surrounding soil, completely saturating it. In many cases the illuminating gas was slightly heavier than the atmosphere, and the manholes formed convenient settling-places into which, in spite of the precautions taken to secure tightness, the gas gradually accumulated, and from various accidental causes occasionally became ignited, producing disastrous results. Such a state of affairs is a serious public menace, and two methods are now in current practice to avoid danger from this source. These may be described as the "*artificial*" and "*natural*" ventilation methods. The "*artificial*" ventilation method may be accomplished in either of two ways. In New York the expedient of laying alongside the cable ducts an additional air-pipe, opening into each of the manholes, and terminating at some convenient point in a blowing station, equipped with a powerful fan, has been adopted. The conduit is as nearly air tight as possible, so that the office of the fan is chiefly that of maintaining a counter-pressure transmitted through the air-pipe to all manholes, thus keeping the whole system under a plenum, and preventing the entrance of any gases whatsoever. That this is the surest and most efficient way is little questioned, but it is too expensive for any but the largest and most expensive installations — the necessary blower plant for a medium-sized conduit system costing from \$60,000 to

\$80,000, while the annual maintenance expense amounts to from \$15,000 to \$20,000. To avoid this installation and operating expense each of the various manholes may be connected with a small standpipe made of 3-inch or 4-inch casing tube (conveniently attached to adjacent buildings), which operate as chimneys to create an air current in the manholes, thus removing noxious gases.

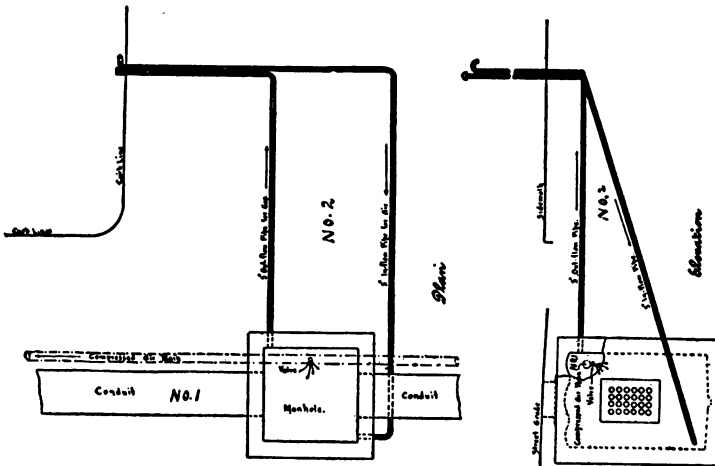

Fig. 53. Ventilating Systems.

While this plan reduces initial expense and obviates maintenance charges, it is burdened with the objection that it constantly operates to produce a slight vacuum in the manholes, and so, while it offers an escape for the gases, it invites their entrance. This system of artificial ventilation is illustrated in Fig. 53. The most recent practice in conduit construction indicates that if prior and subsequent to the introduction of the cables the ends of

the ducts are carefully packed to impede as much as possible the entrance of gases into the manholes, and if the covers are perforated as thoroughly as adequate strength will permit, sufficient ventilation will naturally take place to prevent the formation of explosive gaseous mixtures. Conduit systems are, therefore, now universally installed by dispensing with special methods to produce ventilation, equipping manholes with open covers in the belief that sufficient precautions against subway explosions are thus secured.

Upon the completion of a conduit, provision is necessary for the introduction of cables. This is usually accomplished by what is known as the process of "Rodding." Workmen are supplied with a number of light jointed rods, either of wood or pipe, of such a length as to be readily handled on the inside of the manholes. It is desirable that the joints should be hook joints instead of screwed joints, so that the rods may not unscrew as they are forced through the duct. Rod after rod is introduced into a duct, the succeeding one being attached to the preceding one by its proper joint. In this manner the rods are gradually pushed from one manhole into the next one. As soon as the first rod arrives in the second manhole, a rope is attached to the end of the rod in the first one, and the workman in the second manhole pulls the rod and its attached rope along, disjuncting the successive pieces as fast as they arrive. Then the rope is attached to a fish wire — usually a piece of No. 10, B.W.G., galvanized iron wire, which is pulled into the duct and left in place to serve as the primary means for pulling through the duct the rope to which the cable is subsequently attached.

After the fish wire is in place it is desirable to plug each end of each duct with a hard wood plug, in order to prevent the incursion of gas into the manhole, and to avoid the collection of all sorts of débris in the ducts themselves. Where many ducts are to be rodded simultaneously, the process of pneumatic rodding may be conveniently employed. By this plan the workman in one manhole is furnished with what is technically called a "mouse." This consists of a small spool-shaped piece of wood carrying a leather washer on each of its ends, that closely fit the bore of the duct. To the rear end of the mouse a light line is attached. In the other manhole the workmen are provided with an air-pump carrying a leather cup that enables it to be readily attached to the mouth of the duct. The mouse being placed in the end of a duct, a few strokes of the air-pump produces a sufficient vacuum to cause the mouse to fly swiftly through the duct, dragging the cord after it, and make its appearance at the end where the air-pump is applied. When ducts are reasonably free and clear, and a large number are to be rodded, this process materially reduces the necessary time and expense.



## CHAPTER VII.

**THE COST OF CONDUITS.**

THE cost of a conduit system will be directly proportional to its length, and depends on, but will not be exactly proportional to, the number of ducts. This is almost self-evident, for slight consideration shows that certain of the items of expense are independent of the number of cable spaces, others are partially dependent thereon, while the remainder vary directly with the number of ducts installed. Thus, the cost of manholes will be the same whether few or many ducts are placed; engineering expense, the cost of lighting, watching, protecting and cleaning the street will be the same irrespective of the size of the subway. For necessary working room a certain width of trench must be opened, and if the required number of ducts does not need a wider trench the cost of excavation and paving will be constant. When, however, a greater number of ducts is to be placed, a wider trench than is essential for working room must be excavated, and then the cost of excavation and paving will become partially proportional to the number of ducts. Finally, the expense of the duct material, the cost of labor of laying and that of the surrounding concrete encasement will depend exactly upon the number of ducts.

The fundamental items of cost entering into the expense of conduit construction are ten in number:

1. Duct material.
2. Cement.
3. Sand.
4. Broken stone.
5. Brick.
6. Wrought iron.
7. Cast iron.
8. Lumber.
9. Paving materials.
10. Labor. (a) Skilled labor. (b) Unskilled labor.

These fundamental units will vary with different localities and times. For ease in calculation it is convenient to express these fundamental costs in certain derived units, and to assign to each such a range of variation as is likely to cover probable change within reasonable place and time limits. The derived units are:

1. Duct material.
2. Pavement per square yard.
3. Street excavation per cubic foot, including the removal of paving, the refilling of the excavation after the ducts are laid, and the temporary replacement of the paving.
4. Concrete deposited in place.
5. Labor of placing duct material.
6. Engineering expenses.
7. Manholes.
8. Removal of obstacles.

Of all these derived units, the cost of manholes is least dependent on the number of cable spaces, the cost of this item varying only with the total cost of each manhole and the distances apart that they are set. Table No. 4 gives the itemized cost of various types of manholes. For each item three prices are given: One a minimum price, estimated as that required under the most favorable circumstances; second, an average price, that which is likely to obtain under usual conditions; and, third, a maximum price, or that likely to be required under the more severe requirements of congested city construction, and where work has to be prosecuted at least partially out of working

hours to avoid too great interruption to traffic. For each price a parallel column to that showing the cost of the various items is given, in which the percentage that each item bears to the total cost is calculated. Therefore, with any change in the unit prices, it is easy to estimate the effect that this change will have upon the total cost.

TABLE No. IV.

*Cost of Manholes in Dollars.*

## A. BRICK WITH BRICK ROOF.

ITEM.	AMOUNT.	RATE (\$).			Min. Amt. \$	Per Cent.	Ave. Amt. \$	Per Cent.	Max. Amt. \$	Per Cent.
		Min.	Ave.	Max.						
Excavation,	375 cu. ft.	.02	.03	.04	7.50	12.6	11.25	11.8	15.00	11.2
Concrete . .	.7 yards	5.00	7.00	9.00	3.50	5.9	4.90	5.3	6.00	4.4
Brick . . .	2200	12.00	15.00	18.00	26.40	44.5	33.00	35.3	39.60	29.4
Cover . . .	1	5.00	10.00	15.00	5.00	8.4	10.00	10.6	15.00	11.2
Iron . . .	500 lbs.	.015	.03	.05	7.50	12.6	14.00	16.1	25.00	18.6
Repaving . .	6 yards	.75	2.00	4.00	4.50	7.6	15.00	12.8	24.00	17.8
Cleaning . .	10 loads	.50	.75	1.00	5.00	8.2	7.50	8.1	10.00	7.4
Totals . . .	. . . .	. . . .	. . . .	. . . .	59.40	100.0	93.65	100.0	134.60	100.0

## B. BRICK WITH CONCRETE ROOF.

ITEM.	AMOUNT.	RATE (\$).			Min. Amt. \$	Per Cent.	Ave. Amt. \$	Per Cent.	Max. Amt. \$	Per Cent.
		Min.	Ave.	Max.						
Excavation,	375 cu. ft.	.02	.03	.04	7.50	14.8	11.25	14.4	15.00	13.8
Concrete . .	1.9 yards	5.00	7.00	9.00	9.50	18.7	13.30	17.0	17.10	15.7
Brick . . .	1600	12.00	15.00	18.00	19.20	37.8	24.00	30.9	28.80	25.7
Cover . . .	1	5.00	10.00	15.00	5.00	9.0	10.00	12.8	15.00	13.8
Repaving . .	6 yards	.75	2.00	4.00	4.50	8.9	12.00	15.4	24.00	21.9
Cleaning . .	10 loads	.50	.75	1.00	5.00	9.9	7.50	9.5	10.00	9.1
Totals . . .	. . . .	. . . .	. . . .	. . . .	50.70	100.0	78.05	100.0	109.90	100.0

C. CONCRETE MANHOLE.

ITEM.	AMOUNT.	RATE (\$).			Min. Amt. \$	Per Cent.	Ave. Amt. \$	Per Cent.	Max. Amt. \$	Per Cent.
		Min.	Ave.	Max.						
Excavation, 375 cu. ft.		.02	.03	.04	7.50	16.8	11.25	15.5	15.00	14.3
Concrete . . . . .	4.5 yards	5.00	7.00	9.00	22.50	50.5	31.50	43.6	40.50	38.8
Cover . . . . .	1	5.00	10.00	15.00	5.00	11.2	10.00	13.9	15.00	14.4
Repaving . . . . .	6 yards	.75	2.00	4.00	4.50	10.2	12.00	16.6	24.00	23.0
Cleaning . . . . .	10 loads	.50	.75	1.00	5.00	11.3	7.50	10.4	10.00	9.5
Totals . . . . .	. . . . .	. . . . .	. . . . .	. . . . .	44.50	100.0	72.25	100.0	104.50	100.0

Whenever practicable, a sewer connection to each manhole is desirable to provide exit for street drainage. Such sewer connections are essential in all cases where manholes are equipped with ventilating covers, otherwise the manholes will assuredly fill during every storm. Cases will arise when, either due to the absence of sewers, or to their relative grade with reference to the manhole bottom, a connection of this kind is impracticable; and so the cost of sewer connections has been estimated separately, and is shown in Table No. 5. This table is prepared in a similar manner, a minimum average and maximum price being shown, and the percentage of each item to the total calculated.

TABLE No. V.

Cost of Sewer Connections in Dollars.

AMOUNT.	RATE (\$).			Min. Amt. \$	Per Cent.	Ave. Amt. \$	Per Cent.	Max. Amt. \$	Per Cent.
	Min.	Ave.	Max.						
225 cu. ft.	.02	.03	.04	4.50	35.1	6.75	26.0	9.00	21.4
5 yards	.75	2.00	4.00	3.75	29.2	10.00	38.8	20.00	47.0
1	1.00	2.50	4.00	1.00	7.6	2.50	19.6	4.00	9.3
16 ft.	.04	.07	.10	.64	5.0	1.12	4.4	1.60	3.6
2 loads.	.50	.75	1.00	1.00	7.6	1.50	5.8	2.00	4.7
1	2.00	4.00	6.00	2.00	15.5	4.00	15.4	6.00	14.0
. . . . .	. . . . .	. . . . .	. . . . .	12.89	100.0	25.87	100.0	42.60	100.0

Manholes will occur at intervals of from 250 to 500 feet, consequently the constant cost per conduit foot for this item is obtained by dividing the various manhole costs by the distances between them. In Table No. 6 manhole cost per conduit foot for each of the various styles of manholes given in Table No. 4 for a minimum, average and maximum price is calculated for distances from 250 to 500 feet, varying by 50 feet. In this table

TABLE No. VI.

*Constant Cost per Conduit Foot for Manholes in Dollars.*

	DISTANCE BETWEEN MANHOLES IN FEET.					
		250	300	350	400	500
Brick Manhole with Brick Roof.	{ Min.	.238	.198	.170	.148	.118
	{ Ave.	.372	.310	.248	.236	.186
	{ Max.	.536	.427	.384	.335	.268
Brick Manhole with Concrete Roof	{ Min.	.203	.169	.145	.127	.102
	{ Ave.	.300	.260	.223	.195	.156
	{ Max.	.440	.363	.314	.272	.218
Concrete Manhole	{ Min.	.176	.148	.127	.111	.089
	{ Ave.	.278	.242	.209	.180	.144
	{ Max.	.416	.347	.298	.260	.208
Sewer Connection	{ Min.	.051	.043	.038	.032	.025
	{ Ave.	.104	.086	.074	.064	.051
	{ Max.	.170	.142	.121	.105	.084

the cost of sewer connections per foot of street is included, calculated in a similar manner. For example, assume concrete manholes spaced 300 feet apart, with average cost price. The cost per foot of conduit for manholes will be 24.2 cents, the cost of sewer connections 8.6 cents; a total of 32.8 cents,

Engineering expense is difficult to estimate, as this item will depend chiefly upon the care and thoroughness with which the conduit is laid. The calculation of this item is best obtained as a "factor of experience," namely, such an amount as extended practice in building large systems of conduit has in the past shown to be adequate for the purpose. Upon this basis, engineering expense will vary from a minimum of 5 cents per conduit foot to a maximum of 12 cents, depending chiefly upon the difficulty of the work.

The cost of the removal of obstacles is another item impracticable to estimate *a priori* with any degree of certainty, as it is impossible to foresee, and usually impracticable to ascertain, even with the greatest care, the impediments to be encountered beneath street surfaces. Here also a resort to experience is necessary to ascertain the amount required for this purpose. The cost of the removal of obstacles falls into the category of semi-variables, for it is evident that a large subway will require a greater expense for this purpose than a small one. But this expense is by no means directly proportional to the number of ducts installed. Experience indicates that this expense will vary for small subways from 10 cents to 62 cents per foot of conduit; for medium-sized ones from 12 cents to \$1.10, and for large conduits from 15 cents to \$2.25.

The cost of paving is partially dependent upon the number of ducts. It is impracticable for workmen to perform their avocations in a trench less than 18 inches wide, and, therefore, a strip of pavement of this width must be opened irrespective of the number of ducts to be

installed. Experience shows that in such a trench it is possible to install three ducts horizontally, and the same number vertically. Consequently in an 18-in. trench the advisable maximum number of conduits is 9; so the cost of paving will be constant for any number of ducts from one to nine. To place more than three ducts horizontally requires the trench to be opened three or four inches wider, which will require a corresponding amount of repaving. Therefore, from 9 to 16 ducts the cost of repaving is again constant. Similarly, the amount of repaving per foot of conduit will increase by three or four inches for each additional duct placed horizontally, while the number of ducts will increase in proportion to the square of this number.

The cost of repaving will further vary with the kind of paving. In Table No. VII., the usual kinds of pavement encountered, the minimum, average and maximum prices per square yard, and cost per conduit foot are given.

Allowing a disturbance of paving for six inches on each side of the trench, the cost per lineal foot for small conduits will vary from 2.3 to 26.3 cents; for medium-sized ones from 4.6 to 29.2 cents, and for large conduits from 6.9 to 35.0 cents.

Similarly the cost of excavation is only partially dependent upon the number of ducts. The necessary width of trench to give working room, and depth to clear gas and water service pipes, will accommodate nine ducts, and so the cost of excavation is constant for this number. For from 9 to 16 ducts four inches additional width and depth must be provided, and for each additional layer of cable spaces horizontally and vertically four inches additional

THE COST OF CONDUITS.

TABLE No. VII.  
 Cost of Paving per Square Yard and per Foot of Conduit in Dollars.

KIND OF PAVING.	COST PER CONDUIT FOOT. DUCTS FROM			AVE. PRICE PER SQ. YARD.	COST PER CONDUIT FOOT. DUCTS FROM			MAX. PRICE PER SQ. YARD.	COST PER CONDUIT FOOT. DUCTS FROM		
	1 to 9	10 to 16	17 to 25		1 to 9	10 to 16	17 to 25		1 to 9	10 to 16	17 to 25
	Sq. Yd.	Sq. Yd.	Sq. Yd.		Sq. Yd.	Sq. Yd.	Sq. Yd.		Sq. Yd.	Sq. Yd.	Sq. Yd.
Quantity per conduit foot . . . . .	.0925	.105	.117	. . . .	.0925	.105	.117	. . . .	.0925	.105	.117
Asphalt . . . . .	.163	.183	.205	2.00	.185	.210	.234	3.00	.276	.315	.350
Asphalt block . . . . .	.208	.218	.263	2.50	.231	.262	.292	3.00	.276	.315	.350
Granite block . . . . .	.138	.157	.176	1.75	.163	.172	.205	2.50	.231	.262	.293
Cedar block . . . . .	.056	.063	.070	.75	.069	.079	.088	1.00	.092	.105	.117
Brick . . . . .	.115	.131	.146	1.50	.138	.157	.176	2.50	.231	.262	.293
Telford . . . . .	.074	.084	.093	1.00	.092	.105	.117	1.25	.116	.132	.146
Macadam . . . . .	.023	.026	.029	.50	.046	.052	.058	.75	.069	.079	.088



excavation in width and depth must be provided. Experience shows that 3 feet 6 inches is a minimum permissible depth for the bottom of subway construction, and that the cost of street excavation will vary from two to four cents per cubic foot of material excavated, including the removal of the pavement, the refilling of the trench and the replacement of temporary paving. The cost of excavation will, therefore, stand as in Table No. VIII.

TABLE No. VIII.

*Cost of Street Excavation per Conduit Foot in Dollars.*

	MINIMUM .02 PER CU. FT.	AVERAGE .03 PER CU. FT.	MAXIMUM .04 PER CU. FT.
1 to 9 ducts . . . . .	.105	.1575	.210
10 to 16 ducts . . . . .	.160	.240	.320
17 to 25 ducts . . . . .	.225	.3375	.450

Table No. IX. summarizes these constant items: for conduits of from one to nine ducts, ten to sixteen ducts, and seventeen to twenty-five ducts, giving the minimum, average and maximum prices of all, together with the percentage that each bears to the total. This table shows that conduits containing nine ducts or less will cost from 32.4 cents to \$1.60 per lineal foot for street work; those containing from 10 to 16 ducts from 41 cents to \$1.87; and those containing from 17 to 25 ducts, from 52 cents to \$2.34. If to these prices the cost per foot of street for manholes be added, as given in Table No. IV. or VI., it is

easy to calculate the total cost per foot of conduit exclusive of duct material for any desired subway. For example, assume a subway of nine ducts, with brick manholes set 350 feet apart, at average prices the manhole cost (Table No. VI.) is 22.3 cents, sewer connections 7.4 cents, other items (from Table No. IX.) 72.25 cents; total cost per foot of street, exclusive of duct material and laying the same, 96.95 cents.

TABLE No. IX.

*Constant Cost per Conduit Foot in Dollars.*

ITEM.	MINIMUM.		AVERAGE.		MAXIMUM.	
	Cost.	Per Cent.	Cost.	Per Cent.	Cost.	Per Cent.
<b>1 to 9 ducts :</b>						
Excavation . . . .	.105	32.6	.1575	23.4	.210	13.0
Paving . . . . .	.695	21.2	.185	27.5	.279	17.4
Engineering . . . .	.05	15.2	.08	11.9	.12	7.5
Removal of obstacles,	.10	32.0	.25	37.2	1.00	62.1
Total . . . . .	.3245	100.0	.6725	100.0	1.609	100.0
<b>10 to 16 ducts :</b>						
Excavation . . . .	.16	38.6	.24	29.1	.32	17.0
Paving . . . . .	.0845	20.2	.222	27.0	.3315	17.7
Engineering . . . .	.05	12.1	.08	9.8	.12	6.5
Removal of obstacles,	.12	29.1	.28	34.1	1.10	58.8
Total . . . . .	.4145	100.0	.822	100.0	1.8715	100.0
<b>17 to 25 ducts :</b>						
Excavation . . . .	.225	43.0	.3375	32.8	.45	19.2
Paving . . . . .	.0970	18.6	.26	25.3	.52	22.2
Engineering . . . .	.05	9.6	.08	7.8	.12	5.1
Removal of obstacles,	.15	28.8	.35	34.1	1.25	53.5
Total . . . . .	.522	100.0	1.0275	100.0	2.34	100.0

The cheapest form of duct material is hollow brick. Depending upon distance from factory and freight rates, the price f. o. b. cars will vary from 1.6 cents to 3 cents

per duct foot; adding expense of inspection, hauling, cleaning, breakage, etc., 2 to 5 cents per duct foot will be the cost delivered alongside the trench. Multiple duct material stands next, costing from 3 to 5 cents f. o. b. cars, or from 3.5 to 6.5 cents per foot on the trench. Cement-lined pipe and cement pipe will cost from 4 to 8 cents on the street, and creosoted wood from 4 to 6 cents.

The cost of placing duct material in the trench varies considerably with the kind employed. Hollow brick has been classed by trades unions as brick masonry, owing to the use of a trowel in laying; for this reason, and from the large number of pieces that must be handled, the expense of placing single-duct material is greater than that of either the multiple duct, cement-lined pipe or cement pipe. The cost of placing hollow brick, including the necessary mortar, may be taken from  $\frac{1}{2}$  to  $1\frac{1}{2}$  cents per duct foot. The cost of placing multiple duct material will vary from .1 cent to 1 cent, depending on the size of the pieces and the difficulties of the trench. Cement-lined pipe and cement pipe cost less to place than hollow brick and more than multiple ducts, varying from .25 cent to 1 cent per duct.

Table No. X. enumerates the probable price for the various forms of duct material laid in place calculated in a manner similar to the preceding table, including a percentage column showing the effect of each item on the total expense.

From the data thus collected, the total cost of a conduit of any size is readily determined by taking first the cost per foot of street for manholes and sewer connections (Table No. VI.), second, the cost of the constant street

items as given in Table No. IX., depending upon the number of ducts, and, third, the cost per duct foot, determined from Table No. X., multiplied by the number of ducts to

TABLE No. X.

*Cost of Duct Material in Place in Dollars.*

ITEM.	MINIMUM.		AVERAGE.		MAXIMUM.	
	Cost.	Per Cent.	Cost.	Per Cent.	Cost.	Per Cent.
Hollow brick :						
Duct material . . . .	.02	44.4	.035	36.8	.05	34.5
Placing . . . . .	.005	11.2	.01	10.5	.015	10.3
Encasement . . . . .	.02	44.4	.05	52.7	.08	55.2
Total . . . . .	.045	100.0	.095	100.0	.145	100.0
Multiple Duct :						
Duct material . . . .	.035	67.5	.05	50.0	.065	46.7
Placing . . . . .	.011	2.2	.0025	2.5	.004	2.9
Encasement . . . . .	.015	30.3	.0475	47.5	.07	50.4
Total . . . . .	.061	100.0	.10	100.0	.139	100.0
Cement Lined Pipe . . . . .	....	....	....	....	....	....
Cement Pipe . . . . .	....	....	....	....	....	....
Wood Pulp						
Duct material . . . .	.04	62.5	.06	53.6	.08	48.2
Placing . . . . .	.002	3.2	.004	3.4	.006	3.6
Encasement . . . . .	.022	34.3	.05	43.0	.088	48.2
Total . . . . .	.064	100.0	.114	100.0	.166	100.0
Creosoted Wood :						
Duct material . . . .	.04	98.04	.05	98.0	.06	95.0
Placing . . . . .	.0008	1.96	.0015	3.0	.003	5.0
Encasement . . . . .	.00	0.00	.00	0.0	.00	0.0
Total . . . . .	.0408	100.00	.0515	100.0	.063	100.0

be laid, and adding these three items together, giving immediately the total cost per conduit foot.

The use of these tables as described will give a more accurate, though somewhat more laborious estimate of

cost of conduit construction than it is possible to gain by single assumption of price per duct foot or per conduit foot, as would be necessitated by a cost exhibition in a single tabular or graphical form.

The cost of conduit construction is constantly and steadily decreasing, owing to improvement and cheapening in the manufacture of materials employed, natural com-

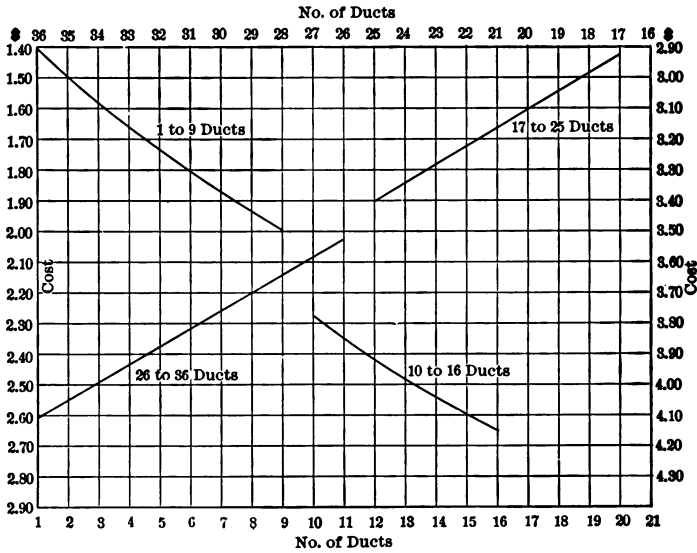

Fig. 54. Cost per Conduit Foot; Average.

petition tending to decrease prices, and increasing experience and skill in designing and building work of this character. Consequently actual conduit costs derived from experience are likely to be higher than would now be required to reconstruct the same system from which they were obtained. Nevertheless, graphical tables, Figs.

54, 55, 56 and 57, are given indicating average and maximum costs of construction of a number of large systems of conduit from actual experience. Fig. 54 shows average costs per conduit foot. Four lines will be found in this table, applying respectively to conduits from 1 to 9 ducts, 10 to 16 ducts, 17 to 25 ducts and 26 to 36 ducts. The horizontal scales at the top and bottom of

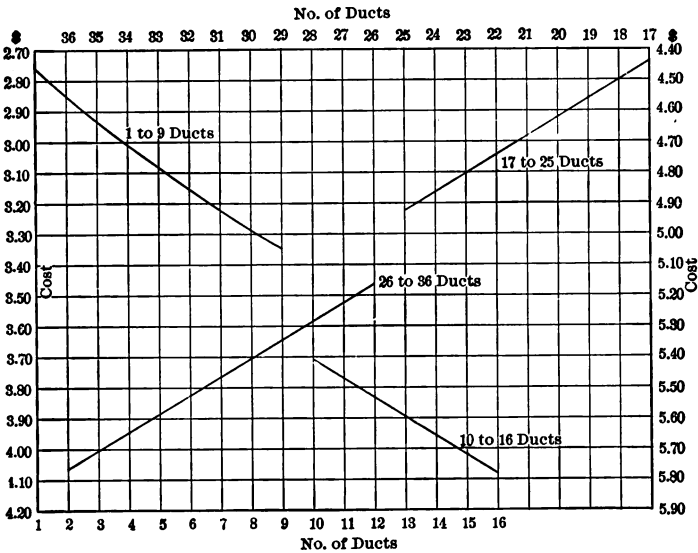

Fig. 55. Cost per Conduit Foot; Average.

these sheets indicate the number of ducts, while the vertical scales at the right and left hand sides respectively give the cost per conduit foot. Fig. 55 is a similar table showing maximum prices. Fig. 54 is likely to apply to the middle and outer portions of large cities of, say, 200,000 inhabitants or over, where street obstructions are not

numerous, and where work can be carried on at usual hours without severe interruption to traffic. Fig. 55 indicates cost in the central portions of similar cities, where obstacles are numerous, and where work must be prosecuted at irregular hours, owing to the impossibility of traffic interruption.

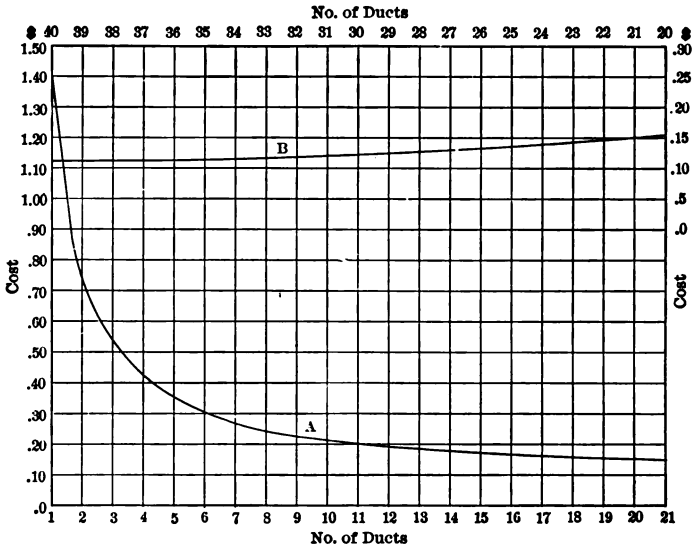

Fig. 56. Cost per Duct Foot; Average.

Figs. 56 and 57 are transformations of tables Figs. 54 and 55, showing cost per duct foot, and are the reciprocals of Figs. 52 and 53.

It has been shown that a large proportion of the cost of conduit construction is independent of the number of ducts installed. It is then a pertinent question as to how many ducts can be economically placed in a conduit sys-

tem when future probable demands are considered. Evidently, if at any future time the conduit system must be increased, the expense of the removal of the paving, excavation and replacement of the street surface must be completely repeated. The cost of the manholes will not need to be reincurred in full, though a certain expense must be

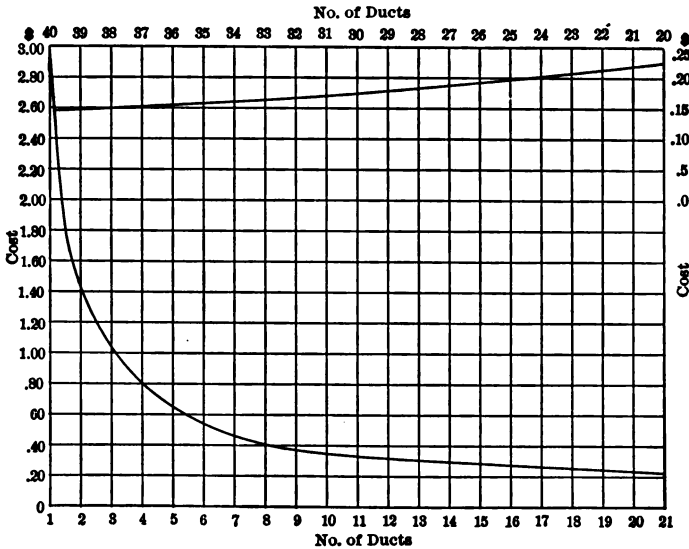

Fig. 57. Cost per Duct Foot; Maximum.

allowed to provide for opening the side walls of the manholes and build in the new ducts. If ducts are installed which are not needed for a long period of time, the interest upon the capital invested in their installation, the inevitable depreciation, the cost of maintenance necessary to keep them in good condition, will form an annual charge against them. The sum of these items must be contrasted



with the cost of opening the street and placing ducts at such future time as will call for increased conduit capacity. If in any instance the probable time elapsing before additional conduit capacity will be needed can reasonably be estimated, the cost of the superfluous ducts placed when the system is built, plus the annual charges against them, may be contrasted with the expense of in-

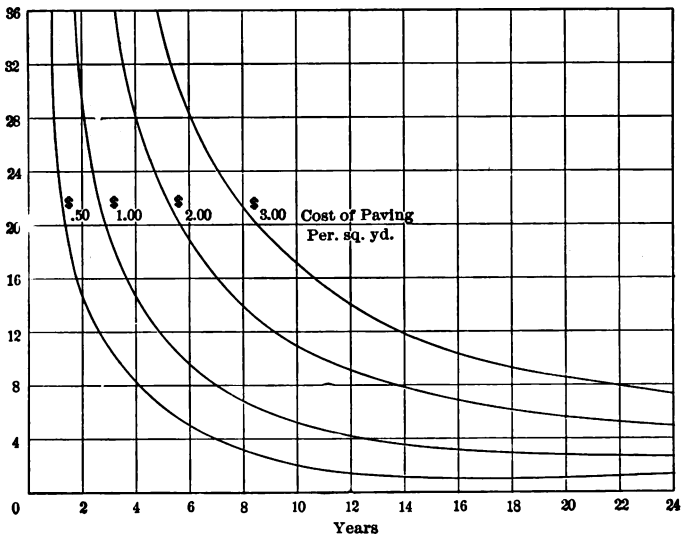

Fig. 58. Number of Ducts.

stallation in the future, and a decision as to which plan is the more economical reached. To facilitate such calculation attention is directed to Fig. 58. This table shows four curves, calculated for varying cost of street paving, from 50 cents to \$3.00 per square yard. The horizontal scale gives the number of years, while the vertical scale

is devoted to the number of idle ducts. The use of the table is illustrated by the following example :

Suppose a conduit of 16 ducts to be in process of construction, and that it is probable that after a certain lapse of time 20 ducts will be needed. The question arises at once, Shall the four additional ducts be placed at the time of original construction, or shall they be left for future installation? Assume paving to be worth \$2.00 per square yard, and that 20 ducts will be needed before the lapse of four years. Select on the left-hand scale the number 20, and follow a horizontal line to curve marked \$2.00, and a vertical line downward to the horizontal scale, finding 5.6 years. The interpretation of this result is that if the 20 ducts are to be needed sooner than 5.6 years, it will be more economical to install them at the original street opening. But if more than 5.6 years will pass before these ducts will be required, it will be cheaper to omit them and reopen the street when additional capacity is required.

## CHAPTER VIII.

**ANNUAL CHARGES.**

IT is necessary to provide for two kinds of annual expense — Depreciation and Maintenance.

*Depreciation.* — There is no human device that even with the best possible care will not gradually wear out, and there are few that escape that destructive march of invention that sooner or later renders it necessary to replace old appliances with those of a more modern and economical design.

Depreciation, therefore, is such an annual allowance as will, at the end of the probable useful lifetime of the plant under consideration, provide a sufficient sum to pay the entire cost of complete replacement. It is folly to ignore this charge, for if, owing to a false sense of security, such provision be omitted, the fateful day of reckoning will surely arrive when an empty treasury and a plant that is worn out or obsolete render bankruptcy inevitable. There are many cases in which the permissible rates of depreciation may be simply that necessary to provide for the actual wearing out of the plant, due to natural destructive causes, and, in some instances, for example earthwork construction, the rates may be very low, for such structures are almost imperishable. But with dynamic machinery,

which is constantly in operation, where the wear and tear are much greater, higher rates are necessary. In the case of telephone installations, particularly at the present time, a large factor in the depreciation account is the constant improvement in methods and systems which renders the best constructed plants obsolete and valueless long before they are actually worn out. There are few telephone offices in the country that have survived five years without rebuilding, and none that have lived a decade, owing to the very rapid improvements which have taken place in switchboard and sub-station construction. With the wire plant, life is longer as the rate of improvement is slower, and, in case of underground construction, the plant is on the whole of a durable character.

Depreciation is usually, and most conveniently, expressed at such an annual percentage rate upon the prime cost of construction as will amount at the end of the probable lifetime of the plant to the cost of replacement. Strictly speaking, legal rates of interest on each of the annual amounts set aside should be allowed for the number of years each is held in reserve. But as this refinement adds to the labor of calculation, and as the probable lifetime of plants varies considerably with time and place, sufficient accuracy is usually secured by the simple plan of annual percentage.

As actual experience with underground conduits does not extend over more than a decade and a half, rates of depreciation must be largely estimated. Methods of manufacturing duct material are being improved; competition tends to reduce prices; superior and cheaper methods of street construction all operate to reduce de-

preciation charges upon subways. Conduits constructed of terra-cotta, in concrete, from all experiences with similar structures, are of great durability. Doubtless, well-burned and well-placed clay laid in first-class concrete would be, if undisturbed, almost everlasting, but even with the best inspection, some defective work will creep in; the constant upheaval of city streets tends to disturb the security of all underground structures, and, finally, there is always a chance of either such improved methods of construction, or the rearrangement of sub-stations as will necessitate the abandonment of existing wire-ways.

For these reasons  $3\frac{1}{2}$  per cent on the cost of main conduit runs, in installations of magnitude, is the lowest advisable rate. For smaller systems, and the branch lines of larger ones, where changes are imminent, 5 per cent should be allowed, while for lateral ducts, frequently constructed of perishable materials, 10 per cent is necessary. For conduits of creosoted wood, or other materials more perishable than terra-cotta, from 8 to 15 per cent for both main and lateral runs should be allowed.

*Maintenance.* — It is somewhat difficult to draw a sharp line of demarcation between depreciation and maintenance, for the same charge under one set of circumstances would appear as depreciation, and at another time and under different conditions as maintenance.

Maintenance is best defined as that annual expense which is required to keep a plant in constant uniform running condition, other than that which is chargeable to general decay or the march of invention. For example, the cost of replacing an old rotten pole line is properly chargeable to depreciation, while the expense of rebuilding

a new line blown over by a cyclone is maintenance. The cost of removing a line that had been in service, say for five years, should be charged half to depreciation and half to maintenance. The expense of repairs to a switchboard damaged by fire should be charged to maintenance, while the purchase of a new switchboard to replace an obsolete though otherwise serviceable one, is depreciation. Maintenance, like depreciation, is most conveniently estimated as an annual percentage on the prime cost of construction, but no interest can be allowed on maintenance funds, for they are drawn upon from day to day. Theoretically, only such a sum should be appropriated to maintenance as can carry the plant through one fiscal year. If by good luck or good management there is an unexpended balance, it may be returned to general profit and loss account, though where estimates are careful, it is wiser to charge such surplus to deferred maintenance, and keep it for that day of misfortune that the Fates always have in store.

An underground conduit would, at first sight, appear to require an almost infinitesimal amount of maintenance, but further consideration reverses this opinion. It is constantly necessary to watch and guard a subway system. Manhole covers are displaced and broken by the impact of passing wheels, and must be renewed; vaults must be cleaned out, and the masonry repointed and repaired; street paving around vault frames and along the line of the trenches is subject to settlement, and must be resurfaced; ever-occurring street excavations tend to disturb and injure conduits, and must be watched, and, if necessary, repairs made. Maintenance expense can only be

determined as a "factor of experience." For large systems, in favored localities, maintenance may fall as low as one per cent, while in small plants, or under unfavorable conditions, three to four per cent is necessary.

Adding, therefore, depreciation and maintenance charges, the annual expense of large subway systems will be from  $4\frac{1}{2}$  per cent to 5 per cent for the main runs. For small plants, and the outskirts of large ones, from 5 per cent to 7 per cent is required. While for ducts of perishable materials from 10 per cent to 15 per cent must be calculated on.

CHAPTER IX.

CONDUIT BUILDING.

ELECTRICAL circuits of all forms are so rapidly being placed underground that conduit construction is becoming a branch of general contracting. Even the largest telephone companies often find it to their interest to build subways by contract; but whether the work is contracted or done by the company by day's work matters little in the desirability of having a definite and distinct specification of exactly what shall be done. When subways are to be built by contract, it is customary to invite bids, either by an advertisement in the daily press, or by letters addressed to the principal contractors, of which the following may serve as a general type:

Proposals will be received by the.....  
 Telephone Co. at its office No.....Street,  
 .....up to noon of the.....day of.....19.....,  
 for the construction of a conduit system in the City of  
 .....of about.....duct feet. Contractors  
 can secure plans, specifications, and all information at the  
 office of the company. The company reserves the right  
 to reject any or all bids, or to divide the contract into two  
 or more parts.

..... *Gen. Mgr.*



Copies of the following or a similar specification and contract should be prepared, together with blue print maps showing the location of all ducts, manholes, and laterals, and delivered to all contractors desiring to bid. At the expiration of the advertised time the proposals should be opened and tabulated to detect any unbalanced bids, and when the successful contractor is selected the contract should be signed by him and the company in duplicate. Formalities are completed by the execution on the part of the contractor of the required bond. Should the company elect to build conduit itself by day's work, the same specification may be employed; but under these circumstances no contract or bond is needed, and may be canceled. Superintendents and foremen of construction should be liberally supplied with copies of the specification and held strictly accountable for the enforcement of all its provisions.

GENERAL CONTRACT AND SPECIFICATIONS FOR  
UNDERGROUND CONDUITS.

THIS AGREEMENT made and concluded this.....  
day of.....in the year Nineteen Hundred and.....  
by and between the.....COMPANY,  
a corporation organized and existing under the laws of the  
State of.....having its principal business  
office in....., party of the first  
part, and.....of the  
City of.....State of.....  
party of the second part, WITNESSETH:

SECTION 1.

**Contract.**

That the party of the second part has agreed, and by these presents does agree with the party of the first part, for and in consideration of the prices, and agreements hereinafter set forth, well and truly to be paid and performed by the party of the first part, and under the penalty expressed in a bond bearing.....date with these presents and hereunto attached, to perform at his own proper cost, all of the work or portions thereof, and to furnish all labor, materials, machinery, tools and appurtenances herein specified, entirely in accordance with the specifications and plans hereinafter referred to, and subject to the approval of the municipal authorities of the .....

SECTION 2.

**Definitions.**

All words referring to the respective parties shall be taken to be of such number and gender as the character of the parties require.

(a) The word "Company" shall mean the.....COMPANY, which has entered into this contract as party of the first part.

(b) The word "Contractor" shall mean the party of the second part thereto, who has entered into this contract to perform the work called for by the specifications.

(c) The word "Engineer" or "Superintendent" shall mean the Engineer or Superintendent of the.....

.....COMPANY as the case may be, acting either directly or through his proper agents.

(d) The word "Conduit" shall mean the aggregation of a number of hollow tubes of duct material arranged to furnish so many longitudinal passageways in the streets, for the reception of electric cables. A section of conduit shall mean such a portion of conduit as connects any two adjacent manholes, measured between the centers of these manholes.

(e) The word "Duct" shall mean a single continuous longitudinal passageway extending between any two adjacent manholes, or from one manhole to any distributing point.

(f) The phrase "Duct Material" shall mean any suitable material out of which ducts may be built.

(g) The term "Manhole" shall mean an underground vault or chamber so built as to give access to a portion of the conduit, and into which the conduit is built, including an opening from the street surface by which access may be had thereto.

(h) The word "Lateral" shall mean one or more ducts extending from a manhole, or from one or more of the main conduit ducts to some distributing point.

### SECTION 3.

#### Description and Location.

##### No. 1. General Specifications.

The work consists in furnishing all labor, materials, machinery, tools, and appliances that shall be needed to build and complete, including all excavations, refilling, and re-

paving, in accordance with these specifications and plans, the requirements of the Engineer or Superintendent and City authorities, the Underground System, as indicated in the schedules and plans accompanying these specifications, together with such additions or subtractions as may be directed by the Engineer or Superintendent, from time to time during the progress of the work, as hereinafter provided.

**No. 2. Schedule A.**

List and location of Conduits.

.....  
.....

**No. 3. Schedule B.**

List and location of Manholes.

.....  
.....

**No. 4. Schedule C.**

List and location of Laterals.

.....  
.....

**SECTION 4.**

**Changes in Location.**

The Schedules A, B and C give the location and enumeration of the conduits, manholes and laterals that it is now the intention to build, but it is agreed that from time to time during the prosecution of the work, and before the final completion thereof, any additions, extensions or subtractions shall be constructed by the second party if required by the first party. The terms and conditions of this agreement shall apply to, and cover all such additions

and extensions, provided that such work is reasonably similar to that which is now contemplated by said schedules. It is also agreed that the first party may decrease the amount of work in any way it shall deem advisable, without becoming liable to the second party for any compensation or damage from such change, provided the first party shall notify in writing the second party of any and all changes before instructions are given for the commencement of work upon the portions which are changed.

## SECTION 5.

**Delivery of Material Supplied by the Company.**

(a) The duct material shall be delivered to the Contractor, either in F.O.B. cars or boat in ..... City, or at the store yard of the Company, at ..... and the Contractor must provide sufficient facilities to haul away and to store the duct material as fast as it shall be received. If delivered to the Contractor F.O.B. cars or boat, he shall be responsible for all damage or demurrage charges which may be incurred by failure to remove the material from the cars, freight yards or freight houses within the time usually allowed by the transportation companies for this purpose.

(Cancel paragraph (a) if duct material is supplied by Contractor.)

(b) The iron work for the manholes shall be delivered to the Contractor either at the foundries making the same, or at the store yard of the Company or F.O.B. cars or boat in the City of..... The Con-

tractor must provide sufficient facilities to remove, haul and store this material as fast as it may be delivered.

(Cancel paragraph (b) if iron work is supplied by Contractor.)

(c) Upon the delivery of any material to the Contractor, he shall give a written receipt to the Engineer or Superintendent for the same, and after the delivery the Contractor shall be responsible for the safety and care of all such material, shall do all the handling and storing at his own expense, and shall replace at his own expense any and all material which may be lost or injured. On the completion of the work herein called for, if any material supplied by the Company shall be unused, the Contractor shall deliver at his own expense to the store yard of the Company any and all surplus material of every kind. If the Company shall fail to deliver to the Contractor from time to time any of the material herein specified to be furnished by the Company, the Contractor shall not allege any such failure as any ground for damages. But for each and every day that the Contractor is delayed by the failure of the Company to deliver said material, he shall be allowed one extra day's time over and above that hereinafter stipulated for the entire completion of the work called for.

#### SECTION 6.

##### **Power of Engineer or Superintendent.**

All work under this contract shall be done to the satisfaction of the Engineer or Superintendent, who shall, in all cases, determine the amount, quality, acceptability and fitness of the several kinds of work and materials which

are to be paid for hereunder, and who shall also decide all questions which may arise as to the fulfillment of any or all of the several clauses of this contract and specifications. The decision of the Engineer or Superintendent shall be final, and binding on the Contractor, and in case any question shall arise, such decision shall be a condition precedent to the right of the Contractor to receive any money hereunder.

#### SECTION 7.

##### **Work to be Done in Accordance With Plans, Specifications and Instructions.**

###### **No. 1. Plans and Instructions.**

Attached to this contract are plans showing the general location of the Underground System herein called for, so far as this location can be pre-determined, but during the progress of the work the Engineer or Superintendent will give to the Contractor such specific instructions and plans as will fix the exact location upon each street of the conduits, manholes and laterals, both line and grade, and the work shall be done in accordance with the plans and specifications annexed and in accordance with such additional plans and directions as may be given. For each section of conduit, for each manhole, and for each lateral the Engineer or Superintendent shall give to the Contractor a detailed plan and working instructions. Such plans or instructions shall show the location of the center line of the excavation with reference to the center of the street, the width and the depth of the trench for the conduit, the laterals and the manholes, and shall specify any points intermediate between manholes, at which there

may be any change in width or grade. These plans and working instructions shall specify the grade of the center of the conduit with reference to a level line. The plans and working instructions shall give the number of ducts in each section, and the arrangement of these ducts, both vertically and horizontally, shall show the kind, location and grade of each manhole.

**No. 2. Errors in Plans or Specifications.**

The plans, specifications and instructions are explanatory of each other, and are intended to be sufficiently explicit to cover the proper construction of the work, in so far as it is possible to define work of this character. The Company, however, does not warrant the plans to be absolutely correct, nor that every possible contingency can be covered, but should any discrepancy appear, or any misunderstanding arise as to the import of anything contained either in the plans, specifications or instructions, the Contractor agrees to accept the explanation of the Engineer or Superintendent as final and binding. Any correction of errors or omissions in the plans and specifications may be made by the Engineer or Superintendent when, in his judgment, such correction is necessary for the proper fulfillment of the intention and meaning of the plans and specifications.

**SECTION 8.**

**Orders to Contractor.**

Whenever the Contractor is not present in person upon any part of the work where it may be necessary to give instructions, such instructions as may be given by the Engineer or Superintendent shall be received and



obeyed by the Foreman, or other persons in charge of the particular work in reference to which orders are given.

SECTION 9.

**Access to Work.**

The Contractor shall at all times afford the Engineer or Superintendent access to any and every part of the work and enable him to examine and inspect all machinery, materials or appliances which are used thereon, and all facilities for ascertaining the skill and competency of any and all men employed.

SECTION 10.

**Competent Men, Suitable Tools and Acceptable Materials.**

The Contractor shall employ only skillful, competent and orderly artisans who are thoroughly familiar with and able to do the several kinds of work to which they are assigned. If the Engineer or Superintendent shall find men who, in his opinion, are unskillful, or who are not thoroughly carrying out the provisions of the specifications, or who are disorderly, or who are not suitable, he shall notify the Contractor in writing of his disapproval of such men, and upon receipt of such notice, the Contractor shall discharge from the work any and all such men, and shall not again re-employ them upon this work. The Contractor shall supply all necessary and suitable tools, appliances and machinery for carrying on the work in a proper manner at such a rate as may be requested by the Engineer or Superintendent. If the

Contractor shall fail to supply appropriate tools and appliances or a sufficient amount thereof, the Engineer or Superintendent shall notify the Contractor in writing of this failure, and if the Contractor shall continue to fail for five days to supply such a quantity or quality of tools, machinery or appliances as shall, in the judgment of the Engineer or Superintendent, be suitable and adequate for the purpose, or if the Contractor shall fail to constantly keep all tools and machinery in proper and adequate repair, the Company may then consider that the Contractor has failed in the performance of his part of the contract, and may assume and carry on any or all such portions, and shall charge against the Contractor any and all expense required to complete the same. The Contractor shall also supply a suitable quantity of acceptable materials, which shall meet in all respects all the provisions of these specifications. In case any material whatsoever shall fail to meet the material specifications, or any of the tests prescribed thereunder, or shall not be in accordance with the samples submitted as provided for in these specifications, or shall not be supplied in sufficient quantity, the Engineer or Superintendent shall notify the Contractor in writing of his failure to supply appropriate materials or sufficient quantity thereof, and on receipt of this notice the Contractor shall immediately replace such rejected materials with such as shall fulfill all of the provisions of the specifications, or shall increase the quantity delivered as may be requested. If, forthwith, after such notice the Contractor fails to supply appropriate and acceptable materials or a sufficient quantity thereof, the Company shall

have the right to assume and carry on the work under the clauses for abandonment, as hereinafter specified, and shall charge against the Contractor, any and all expense required to complete the same.

SECTION 11.

**Replacement of Defective Work.**

If the Engineer or Superintendent shall discover that any portion of the work is not constructed in accordance with the specifications, plans and directions, or if he shall find that any portion of the work has been constructed with poor materials, or unskilled labor, or is in any way defective, he shall notify the Contractor in writing of such imperfections and the Contractor shall, upon receipt of such notice, remove at once all such defective work and shall replace the same with that which is in accordance with the plans, specifications and instructions, and which shall meet the approval of the Engineer or Superintendent. In case the Contractor shall fail to remove or replace any or all such defective work forthwith, after receipt of notice of rejection, the Company shall have the right to remove such defective work and to correct or replace same with such as is in accordance with the specifications, and shall charge against the Contractor any and all expense of such replacement.

SECTION 12.

**Legal Authority.**

The necessary legal authority to occupy and open the streets upon which the underground system is to be placed

shall be obtained by the Company, in the form of the customary written permits for such occupation and opening, and shall be delivered to the Contractor as his authority for the work. If after the receipt by the Contractor of this permit the same shall be lost or destroyed, the Company shall on written notice from the Contractor take out a new permit and shall charge against the Contractor all the necessary expense of obtaining such duplicate permit.

#### SECTION 13.

##### **Work to Be Done in Accordance with Law and City Regulations.**

In all operations in any way connected with the work herein specified, the Contractor shall comply with all the laws of the land, and with all the municipal rules, ordinances and regulations affecting in any way the conduct of those engaged, or the methods of doing the work, or in the use of materials, tools, appliances or machines.

#### SECTION 14.

##### **Responsibility of Contractor.**

During the progress of the work the Contractor shall take all precautions and shall assume all responsibility of whatsoever nature for the prevention of any and all injuries to any person whatsoever, whether employed by the Contractor or not. He shall and does hereby assume all responsibility and liability for any injury or damage of whatsoever nature, to any property or persons, and shall and does hereby assume all liens, suits or claims for damages, either to life, limb, property or persons, arising

from any act or omission, or from the amount or character of the work, or the way in which it is done, and shall and hereby agrees to save harmless the Company, its officers and agents from all claims relating to any damage or injury, actual or consequential, present or future.

#### SECTION 15.

##### **Liens Upon the Work.**

Upon the completion of the work and before the final payments are made to the Contractor, he shall file with the Company suitable evidence that all claims or causes of action for damages, that all liens, for payment of wages or payment for tools, machinery or supplies of all kinds have been by him entirely liquidated, released and satisfied, and he shall furnish to the Company a clear title to all the work, and to each and every part thereof.

#### SECTION 16.

##### **Subletting or Assignments.**

The Contractor shall constantly give his personal attention to the faithful prosecution of the work, and from beginning to end shall keep the same entirely under his personal control. He shall not assign or sublet the work, or any part thereof, without previously obtaining the written consent of the Company, nor shall he either legally or equitably assign any of the moneys payable under this agreement, or his claim thereto, unless by and with the previous written consent of the Company. He shall punctually pay any and all workmen employed on the work, in current money.

SECTION 17.

**Time of Commencement and Completion.**

The Contractor agrees to commence the work within ..... days from the date of execution of this contract, and he agrees to entirely complete, finish and turn over to the Company all of the said work within ..... days thereafter, Sundays and legal holidays excepted.

SECTION 18.

**Damages for Delay in Completion.**

In case the Contractor shall fail to complete the entire amount of work called for in the schedules attached to this contract, within the time specified under Section 17, the Company shall have the right to deduct and retain out of the moneys which may be due, or may become due the Contractor under this contract, the sum of .....dollars per day as liquidated damages for each and every day that the entire work under this contract shall remain uncompleted over and above the time hereinbefore specified in Section 17, Sundays and legal holidays excepted.

SECTION 19.

**Company's Right to Assume Work.**

If this work or any part thereof shall be abandoned, or if it or any portion shall be sublet or any claim thereunder shall be assigned otherwise than as provided, or if the Engineer or Superintendent shall be of the opinion,

and shall so certify in writing to the Company, that the conditions herein specified are not fulfilled, or that the work or any part thereof is unnecessarily delayed, or that the Contractor is violating any of the provisions of this contract, the Company may notify the Contractor to discontinue all work, or any part thereof, and thereupon the Contractor shall discontinue said work, or such part thereof as the Company may designate, and the Company may, by contract or otherwise, as it may determine, complete the work or such part thereof, and charge the expense thereof to the Contractor, and may use therefor any and all materials, animals, machinery, implements and tools of every description as may be found upon the line of said work. The expense so charged shall be deducted and paid by the Company out of any moneys then due, or to become due the Contractor. In case such expense is less than the sum which should have been payable under this contract, if the same had been completed by the Contractor, the Contractor shall be entitled to receive the difference, and in case such expense shall exceed the latter sum, the Contractor shall on demand pay the amount of such excess to the Company.

#### SECTION 20.

##### **Extra Work.**

The Contractor shall do no work nor supply any materials not herein provided for, unless directed in writing by the Engineer or Superintendent, and he shall make no claim for any extra work or materials excepting as authorized by the Engineer or Superintendent in writing, and

the Contractor shall file with the Engineer or Superintendent a statement of all such extra work or materials, with a copy of the order therefor and a statement of the place where such work or materials were furnished, and shall give an itemized statement of, and vouchers for, the quantities and prices of any and all such work, or material.

#### SECTION 21.

##### **Acceptation of Work.**

###### **No. 1. Inspection.**

Upon the completion of any section of conduit or of any lateral, the Contractor shall notify the Engineer or Superintendent that, in his opinion, the said section of conduit or lateral is complete. Within three days after the receipt of such notification, the Engineer or Superintendent shall inspect such section or lateral, and if he shall find this work has been performed in accordance with the provisions of these specifications, all and singular, and in conformity with any additional plans, or directions, he shall then give to the Contractor a certificate of *Preliminary Inspection*. If the Engineer or Superintendent shall find that in any particular this work does not correspond with the plans, specifications or instructions, he shall notify the Contractor thereof in writing, specifying the defects. The Contractor shall then immediately remove any defective materials or rectify any imperfect construction. When such defective work is removed and replaced with such as is satisfactory to the Engineer or Superintendent, he shall issue to the Contractor a certificate of preliminary inspection.



**No. 2. Condition of Final Acceptance.**

On the completion of all the work called for in the schedules attached, and any additions thereto, the Engineer or Superintendent shall make a final inspection of the entire work done and shall measure up all of the quantities of work which have been put in, and the amounts of labor and materials supplied. If this final inspection shall show that all the work is in accordance with the plans, specifications and instructions, and completed to the satisfaction of the Engineer or Superintendent, he shall then render the Contractor a certificate of final acceptance of the entire work, and on receipt of this certificate the responsibility of the Contractor for the work shall cease, and it shall then pass to and become the property of the Company. In case the Engineer or Superintendent shall in this inspection discover any imperfection, he shall notify the Contractor of the same, and the Contractor shall immediately replace any defective work or materials with that which is in accordance with the plans, specifications and instructions, and which is to the satisfaction of the Engineer or Superintendent. The fact that a certificate of preliminary inspection may have previously been rendered to the Contractor for the particular portion on which faulty work or materials is subsequently found, shall not operate to release the Contractor from his obligation at the time of final inspection, to make every part of the work satisfactory in all respects.

SECTION 22.

Conditions of Payment.

No. 1. Estimates.

At the end of every calendar month during the progress of this work, the Engineer or Superintendent shall examine and measure up the amount of work performed by the Contractor during the month in question. This examination shall be made within the first five days of each succeeding calendar month, and on the completion thereof, the Engineer or Superintendent shall render to the Company a statement in detail of the amount of work accomplished during the preceding month, and shall give the Contractor a copy of same. Within ten days after the receipt of this statement the Company shall pay to the Contractor ..... per cent of the amount called for in the statement, and shall reserve ..... per cent thereof until completion of the entire work.

No. 2. Final Payment.

Upon the entire completion of all the work called for in the schedules, and any additions thereto, and upon the final examination and acceptation of all the work by the Engineer or Superintendent, and upon full performance of this agreement in all other respects, the Engineer or Superintendent shall render to the Company a statement to this effect, and shall give the Contractor copy of same. Within thirty days thereafter the Company shall make to the Contractor a final payment for all the work herein called for, which shall include all the balances (except as hereinafter provided) which have been reserved from the preceding monthly payments.

## SECTION 23.

**Prices for Work.**

The Company shall pay as full compensation for everything furnished and done under this contract, including all damage arising out of the nature of the work, or from the action of the elements, and all risks of every description connected therewith, and for all expenses entailed in consequence of the suspension or discontinuance thereof, the following amounts:

**No. 1. Prices for Conduits.**

The prices for conduit hereinafter stated shall mean the price per linear foot for conduits containing the varying number of ducts stated in Table A; a different price shall be given for each number of ducts. The term "Conduit Foot" shall mean one complete linear foot of conduit irrespective of the number of ducts therein, measured along the axis of the conduit, and the length upon which the amounts due the Contractor shall be calculated shall be the length of conduit measured between the inside and adjacent walls of any two adjacent manholes. The following prices shall be full compensation for the removal of the pavement, the excavation of the trench, the placing of the concrete foundation,

the laying of the duct

supplied by the Contractor,

material the refilling of the trench,

supplied by the Company,

temporary paving

and the replacement of the and the

permanent paving

rodding of the ducts as herein specified in Table A.

TABLE A.

*Contract Prices to be Paid per Conduit Foot.*

NUMBER OF DUCTS.	KIND OF DUCT MATERIAL.						
	Iron Pipe.	Pump Log.	Creosoted Wood.	Cement Pipe.	Hollow Brick.	Multiple Duct.	Paper Tube.
2							
3							
4							
5							
6							
7							
8							
9							
10							
11							
12							
13							
14							
15							
16							
18							
20							
22							
24							
26							
30							
36							
48							

**No. 2. Prices for Concrete Manholes.**

For each and every standard manhole built of concrete as hereafter specified, and of the general shape and dimensions shown in Plan I A, B and C attached, including the removal of the paving, the necessary excavation, the supply and manufacture of the mold, the supply, manufacture and placing of the concrete, the placing of the

iron cover supplied by the Contractor  
 the excavation, replacement of the paving  
 and clearing of the street, all as herein specified, the sum of.....dollars.

**No. 3. Prices for Brick Manholes.**

For each and every standard manhole built of brick as hereafter specified, and of the general shape and dimensions shown in Plan II A, B and C attached, including the removal of the paving, the necessary excavation, the supply, manufacture and placing of the concrete for the bottom

all the bricks, mortar, masonry and labor of laying the same, the setting of all the iron for the roof and all iron work supplied by Contractor,  
 the iron cover, the refillment  
 all iron work supplied by Company,  
 of the excavation.  
 replacing of the paving and  
 cleaning of the street, all as herein specified, the sum of .....dollars.

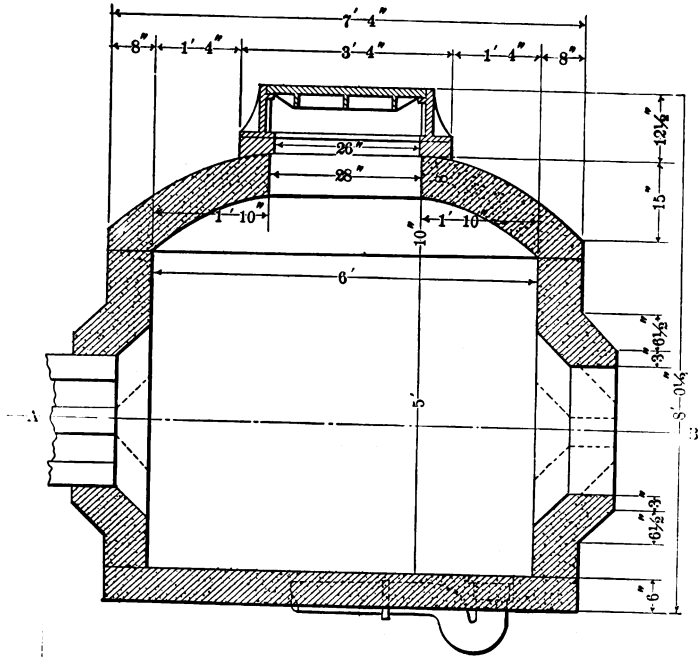

TELEPHONY.

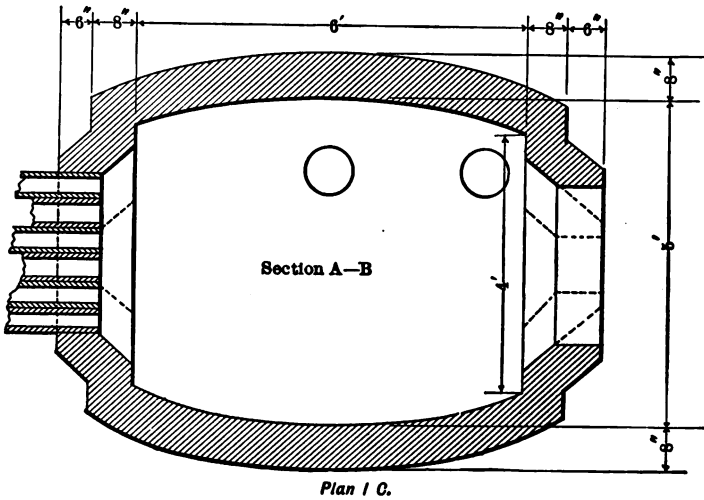
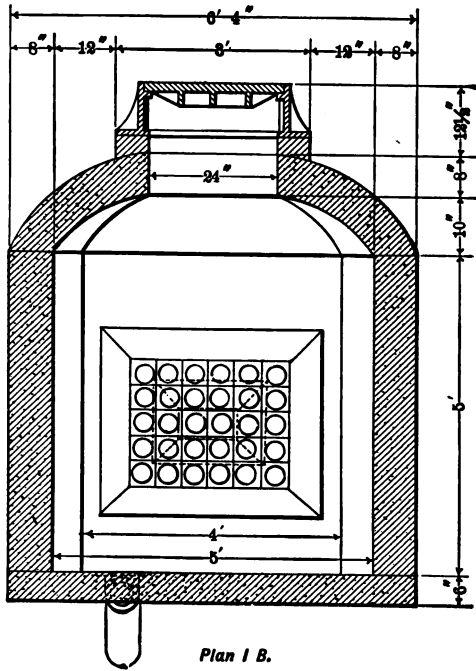

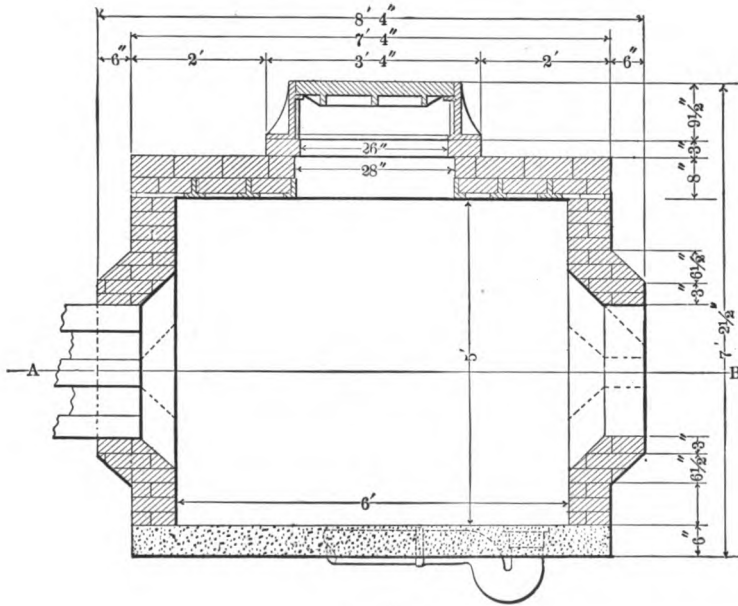

Plan II A.



TELEPHONY.

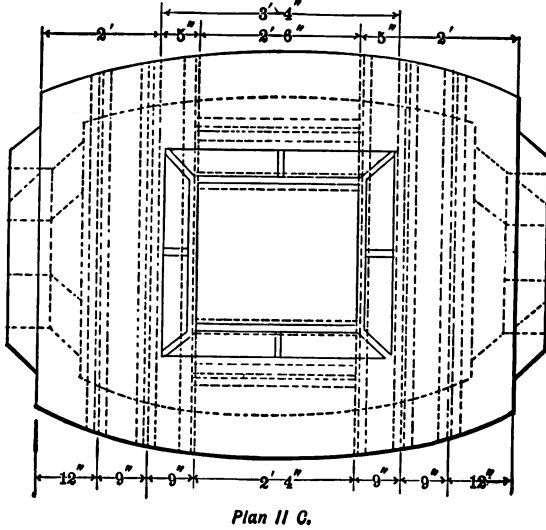
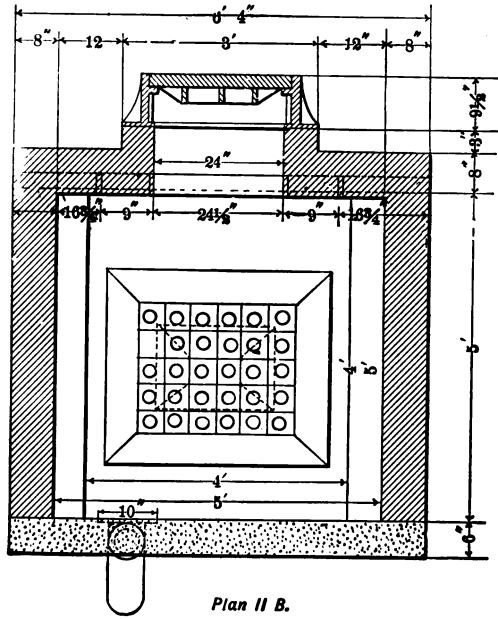

**No. 4. Prices for Sewer Connection.**

For each and every sewer connection made to any man-hole, including necessary excavation, the furnishing and laying of sufficient 4-in. tile drain pipe to the sewer, and the connection of the outer end thereof to the sewer and the inner end thereof to the sewer trap, the furnishing of the sewer trap as specified, including obtaining the necessary sewer permit from the City; the refilling and repaving the excavation, the sum of.....dollars.

**No. 5. Prices for Extra Work.**

For all extra labor or materials supplied in accordance with the written instructions, from the Engineer or Superintendent, the Contractor shall charge cost plus 10% (ten per cent) excepting for such labor or materials as are specified in No. 6.

**No. 6. Prices for Special Extra Materials and Labor.**

(a) For all extra concrete, including all materials and labor for mixing and placing the same, the price of.....dollars per cubic yard.

(b) For all extra brick work, including the necessary brick, mortar, and labor of laying the same, the price of.....dollars per 1,000 brick laid.

(c) For all extra lumber, including the cost of furnishing and placing the same, the price of.....dollars per 1,000 feet board measure.

(d) For all excavation not otherwise included in these specifications, including the removal of the pavement, the refilling of the excavation, the replacement of the paving, and the cleaning up of the street, the sum of.....cents for each and every cubic yard of actual space excavated.

## SECTION 24.

**Material Specifications.****No. 1. Hollow Brick or "Single Duct" Material.**

Hollow brick duct material shall be made of well-burnt vitrified clay. There shall be two kinds of pieces—standard pieces and special pieces. All standard pieces shall be not less than 18 inches long. Special pieces shall be 6 inches, 9 inches, and 12 inches in length, and such a number shall be delivered for each section as may be directed. All pieces shall be either plain square, fluted square, octagonal, or round, in general shape, and joints shall be either butt joints, with or without dowels, or socket joints, as shall be specified for each location.

For butt joints without dowels the outside diameters shall be within reasonable manufacturing limits,  $4\frac{1}{2}$  inches; for single dowel joints,  $4\frac{1}{4}$  inches; for socket joints, plain square, or fluted square, 5 inches; for round and octagonal socket joints,  $4\frac{7}{8}$  inches. For all shapes the bore shall be not less than  $3\frac{1}{4}$  inches diameter at any place; shall be truly circular, centered throughout the entire length of each piece, smooth, clean, and free from all teats, nodules or rough spots. Butt joints shall have the mouth of each piece at each end reamed to a radius of about  $\frac{1}{2}$  inch, and each piece shaped true and square with its axis. Dowel joints shall have at least two dowel holes molded in each end of each piece. These holes shall be accurately molded and shall match the pins—all of which shall be interchangeable among all pieces. With each piece the requisite number of dowel pins shall be supplied to fill one-half the sum of the dowel holes in

both ends. Socket end material shall have one end of each piece bell-mouthed, the other chamfered to fit the bell; all pieces shall be mutually interchangeable. Sockets shall be so designed and made that the addition of a little mortar shall make a tight joint and produce a straight uniform cylindrical cable space.

All hollow brick tile shall be of good, finely ground clay, mixed in the proper proportions and burned thoroughly hard clear through. Each piece shall be well vitrified, but shall not be burned so hard as to be fused or scoriated. The surface of each piece, both inside and out, shall be thoroughly and uniformly glazed with good salt glaze, and shall not contain cracks which extend into the surface more than 1-16 inch. Each piece shall be sound, without soft spots, stones, gravel or any other imperfections. Each piece shall be straight, true and fully up to dimensions specified. The bore of each piece shall be tested and shall pass a standard 3 3-16 inch gauge. All pieces which shall have a bow or curve or kink of more than one-fourth inch shall not be accepted, and no piece shall be accepted if it shall have any curve in more than one plane. All hollow brick tile shall be examined by an inspector appointed by the Company at such a place as shall be directed, and only such pieces accepted as shall fulfill all of these specifications. If required, the Contractor shall scrape or clean each piece through the inside of the bore by an appropriate scraper or cleaner, which shall be subject to the approval of the Engineer or Superintendent. All damaged or rejected pipe shall be removed by the Contractor.

**No. 2. Multiple Duct Material.**

Multiple duct material shall comply with all the provisions of Section 24, No. 1, so far as to quantity of material, size and location of bore, dowels, etc., and shall be of the general dimensions shown in Table B, depending on the number of cable spaces.

TABLE B.  
*Dimensions of Multiple Duct Pieces.*

## THREE INCH DUCTS.

NUMBER OF DUCTS.	HEIGHT AND WIDTH OF END SECTION IN INCHES.	STANDARD LENGTHS IN INCHES.	SPECIAL LENGTHS IN INCHES.	APPROXIMATE WEIGHT PER DUCT FOOT.
Two ducts . . .	$4\frac{3}{4} \times 8\frac{3}{4}$	24	6 and 12	8 $\frac{3}{4}$ "
Three ducts . . .	$4\frac{3}{4} \times 13$	24	6 and 12	8 $\frac{1}{2}$ "
Four ducts . . .	$3\frac{3}{4} \times 8\frac{3}{4}$	36 and 48	6, 9 and 12	8"
Four ducts . . .	$4\frac{3}{4} \times 17$	24	6 and 12	8"
Six ducts . . .	$8\frac{3}{4} \times 13$	36 and 48	6, 9 and 12	8"
Nine ducts . . .	$13 \times 13$	36	6, 9 and 12	7 $\frac{1}{4}$ "
Twelve ducts . . .	$13 \times 17$	30	6, 9 and 12	7 $\frac{1}{4}$ "
Sixteen ducts . . .	$17 \times 17$	30	6, 9 and 12	7 $\frac{1}{4}$ "

**No. 3. Cement Lined Pipe Duct Material.**

The dimensions of each piece of cement lined pipe shall be: length not less than 6 feet; diameter of bore not less than 3 inches; the thickness of cement not less than  $\frac{1}{2}$  inch; the thickness of the iron casing, N. 024 B. W. G. Each piece shall be of uniform section, with bore concentric with shell, straight and truly circular throughout its length. The iron casing shall be of good iron, riveted with  $\frac{1}{8}$  inch rivets set  $1\frac{1}{2}$  inch on centers, and painted on the outside with the best quality of coal-tar paint, asphalt or other approved coating material applied hot. The lin-

ing shall be of pure first-class hydraulic cement without admixture of sand or any foreign material, which shall be applied a sufficient time before shipment to become thoroughly set and sufficiently strong to bear transportation. The cement used for lining shall be an approved quality hydraulic cement, and if required the results of tests for fineness and tensile strength, made as specified in Section 24, No. 7 *a*, shall be submitted to the Engineer or Superintendent for approval. Pipe made from unapproved materials may be rejected. Each piece shall be supplied with approved cast iron socket ends thoroughly and securely attached, of such design as shall make a concentric tight joint. Each and every piece shall be free from cracks, indentures, teats, nodules, depressions, breaks or rough surfaces of any kind; shall be straight, true and full to all dimensions; and shall not have a bow or curve of more than  $\frac{1}{2}$  inch in any plane; and no bend in more than one plane. All pipe shall be cleaned and inspected at such places as may be directed.

**No. 4. Cement Pipe Duct Material.**

Cement pipe shall have an outside diameter of not less than  $4\frac{7}{8}$  inches, and inside diameter of not less than  $3\frac{3}{8}$  inches, and a thickness of not less than  $\frac{3}{4}$  inch. It shall be made of a mixture of first-class Portland Cement, and fine crushed stone pressed into an appropriate form. The cement shall be an approved quality of Portland cement, and if required the results of tests for fineness, tensile strength, etc., made as specified in Section 24, No. 7 *a*, shall be submitted to the Engineer or Superintendent for approval. Pipe made from unap-

proved materials may be rejected. Pipe shall be supplied in lengths of not less than 6 feet, straight, true and fully up to dimensions in every respect, with no bend of more than  $\frac{1}{2}$  inch, and no bend in more than one plane. The inner surface shall present no lumps or roughnesses or be in any way injurious to the cable sheath. The inner edge of each end of each piece shall be rounded to a radius of at least  $\frac{1}{2}$  inch. Pipe shall have been made a sufficient length of time to be amply strong to bear hauling without breakage. The pipe shall be fully equal in quality to that of the standard sample which shall be deposited with Engineer or Superintendent prior to the award of this contract.

**No. 5. Creosoted Wood Duct Material.**

(a) PUMP LOG, SQUARE AND ROUND.

Creosoted wood duct material shall be made of first class, thoroughly seasoned, white or yellow pine. Each piece shall be not less than 4 feet in length and  $4\frac{1}{2}$  inches  $\times$   $4\frac{1}{2}$  inches outside for square log, and not less than  $4\frac{3}{8}$  inches diameter for round log. The sides of each piece of square log shall be at right angles to each other, smooth and true. Round logs shall be turned smoothly and truly from end to end throughout the center of each piece. There shall be a bore fully 3 inches in diameter accurately centered and truly circular. At one end of each piece there shall be a tenon  $1\frac{3}{4}$  inch long, and not less than  $3\frac{1}{2}$  inches outside diameter. On the other end of each piece there shall be a mortise not less than  $1\frac{7}{8}$  inch deep and a snug fit for each tenon, but this fit shall not be so tight as to cause the wood to split when successive

pieces are driven together. All pieces shall be interchangeable. After the pieces are milled they shall be creosoted by the following process :

1st. The lumber shall be steamed in a closed tank with steam at not less than 45 lbs. gauge pressure for at least four hours.

2d. A vacuum of at least 20 in. shall be applied to the tank and the drainage of sap from the timber pumped away. This vacuum shall be continued as long as any sensible drainage of sap or moisture is discharged by the pump.

3d. Pure dead oil of tar shall be pumped into the cylinder and an hydraulic pressure applied sufficient to force into the timber at least 14 lbs. of oil per cubic foot of timber in the charge. The absorption of the oil by the timber shall be determined by measuring the total quantity of oil pumped into the treating cylinder and comparing this quantity with the difference between the volume of the cylinder and the volume of the charge under treatment.

4th. All oil used in treatment shall be pure dead oil of tar, and shall be subjected to a chemical analysis and proved to contain no deleterious substances. It shall possess the following characteristics :

a. It shall be completely liquid at a temperature of 100° F.

b. It shall contain at least 25% of constituents that do not volatilize at a temperature of 600° F.

c. It shall not contain over 5% of tar acids.

d. It shall contain no admixture of any substance not obtained from the distillation of coal tar.



5th. After creosoting is completed all duct material shall be allowed to season at least three months in the open air before being laid.

## (b) VALENTINE CONDUIT.

All lumber used for Valentine conduit shall be of the same quality and treated in the same manner as specified under Section 24, No. 5 a.

The following Table C specifies the cross sectional dimensions of the woodwork for  $1\frac{1}{2}$  in., 2 in.,  $2\frac{1}{2}$  in. and 3 in. ducts:

TABLE C.

*Valentine Duct Material.*

## SIZES OF CONDUIT.

1½-IN. CONDUIT.			
Conduit containing 1 duct, dimensions			3 × 3
“ “ 2 ducts, “			3 × 5½
“ “ 3 “ “			3 × 7½
“ “ 4 “ “			5½ × 5½
“ “ 6 “ “			5½ × 7½
“ “ 9 “ “			7½ × 7½
“ “ 12 “ “			7½ × 9½
2-IN. CONDUIT.			
Conduit containing 1 duct, dimensions			3½ × 3½
“ “ 2 ducts, “			3½ × 6½
“ “ 3 “ “			3½ × 9
“ “ 4 “ “			6½ × 6½
“ “ 6 “ “			6½ × 9
“ “ 9 “ “			9 × 9
“ “ 12 “ “			9 × 11¾

**2½-IN. CONDUIT.**

Conduit containing 1 duct, dimensions . . . . .	4 × 4½
“ “ 2 ducts, “ . . . . .	4½ × 7¾
“ “ 3 “ “ . . . . .	4½ × 11
“ “ 4 “ “ . . . . .	7¾ × 7¾
“ “ 6 “ “ . . . . .	8 × 11
“ “ 9 “ “ . . . . .	11 × 11½
“ “ 12 “ “ . . . . .	11 × 15

**3-IN. CONDUIT.**

Conduit containing 1 duct, dimensions . . . . .	5 × 5
“ “ 2 ducts, “ . . . . .	5 × 8¾
“ “ 3 “ “ . . . . .	5 × 12½
“ “ 4 “ “ . . . . .	8¾ × 8¾
“ “ 6 “ “ . . . . .	8¾ × 12
“ “ 9 “ “ . . . . .	12½ × 12½
“ “ 12 “ “ . . . . .	12½ × 16¼

Wood slabs shall be supplied in lengths of not less than 8 ft. The top and bottom slab shall be plain and free from grooves on the upper and under sides respectively. Along each edge of each piece outside the outer cable space a groove shall be cut into which a dovetail shall be fitted capable of making a tight joint with the succeeding slab. All dovetails and grooves shall be accurately and carefully milled, and all pieces shall be mutually interchangeable in such a manner that when assembled all cable spaces shall be truly round and circular and in their proper mutual relative position.

**No. 6. Wrought Iron Pipe Duct Material.**

Wrought iron pipe duct material shall be of good quality of wrought iron or mild steel, known as casing pipe. The pipe shall be supplied in lengths of.....ft., weighing about four pounds per lineal foot, having a thickness of about ½ in., and shall be supplied with a right

hand male screw thread at each end. Each piece shall have fully 3 in. on the inside diameter, and be smooth, true and round in every respect. Pieces having fins, cold shuts, nodules, bad welds or rough places upon the inside, or containing kinks, bends or imperfections of any kind, shall be rejected. The end of each piece shall be cut true and square with the axis, and reamed out to free it from any fins or projecting slivers. The thread upon each shall be standard casing pipe thread, 14 to the inch, truly and smoothly cut and at right angles to the axis. One end of each piece shall be supplied with standard casing pipe socket threaded through to fit the pipe. Each piece shall be thoroughly painted inside and out with two coats of tar paint, asphalt or other approved coating material applied hot.

**No. 7. Cement.**

For all concrete and mortar, an approved quality of cement shall be applied; all cement shall be subjected to the following tests and conditions:

(a) METHOD OF TESTING.

Before using any cement the Contractor shall submit to the Engineer or Superintendent samples of any brands which he proposes to employ, and if at any time the Contractor wishes to change the kind of cement, he shall again submit a sample for inspection. Each sample shall contain about 50 lbs., and from each sample a sufficient quantity shall be taken to make ten lots of briquettes, each lot containing ten briquettes, of American Society of Civil Engineers standard. The first lot of ten briquettes

shall be mixed with 15% of water by weight, the second lot with 16%, the third with 17%, the fourth with 18%, the fifth with 19%, the sixth with 20%, the seventh with 21%, the eighth with 22%, the ninth with 23%, and the tenth with 24% of water. Briquettes shall be made by thoroughly mixing each weighed quantity of water with the weighed quantity of neat cement and ramming into briquette molds. When sufficiently set, briquettes shall be placed under a damp cloth and kept for twenty-four hours from the time of mixing. Then each lot shall be broken by tension in a standard cement testing machine. The amount of water used with the lot developing for the average of the entire ten the greatest tensile strength shall be taken as the proper quantity of water for mixing with the brand of cement in question. All subsequent tests on this brand shall be mixed with the same per cent of water. From every lot of cement delivered upon the work, the Engineer or Superintendent shall sample such a number of bags, barrels or packages as shall in his opinion be sufficient to determine the quality of the entire lot. If only 60% of these samples tested as above specified shall average 250 pounds per square inch, the lot of cement from which these samples came shall be rejected. If 70% of these samples shall reach 250 pounds, this lot of cement may be either rejected or re-tested, as the Engineer or Superintendent shall see fit. If over 70% shall reach 250 pounds per square inch, the lot shall be accepted.

(b) FINENESS TEST.

Each lot shall be tested for fineness, by sifting a weighed portion through a No. 100 sieve, or one contain-

ing 10,000 meshes per square inch. At least 90% of each sample shall pass the sieve.

(c) SETTING TESTS.

Each lot shall be tested for setting mixed with 5% more water than in the specification for tensile test. Three minutes after the application of the water, a Gilmore needle, namely, wire  $\frac{1}{12}$  in. in diameter and loaded with  $\frac{1}{4}$  pounds, shall be placed on the mixed sample and the length of time and the distance the needle penetrates noted. All samples shall allow the needle to penetrate for at least one minute, and for at least one inch.

(d) STORAGE.

All cement shall be delivered in original packages bearing the mark, brand or designation of the maker. The Contractor shall store cement in such a way as to keep it free from injury by weather. All barrels, bags or packages shall be raised from the ground upon suitable supports, and at all times covered with waterproof covering. If the Engineer or Superintendent shall suspect that any cement has been injured, or that the barrels or packages have been opened or tampered with, or that the cement has been adulterated in any way, he may condemn same. When any cement has been rejected, the Contractor shall within twenty-four hours thereafter remove same, and during the said twenty-four hours he shall take suitable precaution to prevent the rejected cement being used. If the Engineer or Superintendent believes that rejected cement has been used on any part of the work, he may order such work to be taken out and replaced with that made with accepted cement.

*(f)* RATE OF DELIVERY.

The Contractor shall at all times provide such a supply of cement as shall give a sufficient quantity to use for at least 48 hours in advance of any additional deliveries, to allow sufficient opportunity for tests, and in case the Contractor shall not provide sufficient cement to allow the specified 48 hours, the Engineer or Superintendent shall summarily stop the work until a sufficient quantity of cement shall be delivered ahead to allow of 48 hours for testing. For any stoppage of work of this kind the Contractor shall make no claim for delay, and such failure to deliver cement shall not release the Contractor from liability for non-completion, as in Section 18.

**No. 8. Sand.**

All sand shall be first-class fine, sharp, silicious sand, preferably beach, river or lake sand, or fine crushed stone, which is not worn or washed. All sand shall be free from loam, dirt, mica, scales, dust or other foreign matter, and when tested by shaking in water it shall not show more than 1% of suspended matter. Sand shall be tested by sifting samples, and at least 75% shall pass a No. 16 sieve and be retained by a No. 40. Previous to the commencement of the work the Contractor shall submit a sample of sand which he proposes to use. If this sample be approved it shall be retained by the Engineer or Superintendent. All sand used on the work shall correspond with the sample.

**No. 9. Broken Stone.**

All broken stone shall be a first-class quality of granite, gneis, trap or limestone. It shall be broken to have sharp

and irregular angles, and shall pass in all directions through a 1½ inch ring and also be screened to remove dust. Broken stone shall be clean and free from sand, loam or other admixtures. The Contractor shall submit a sample of broken stone, and if approved the Engineer or Superintendent shall retain the same. Stone subsequently delivered shall correspond to the sample.

**No. 10. Brick.**

All brick shall be first-class hard burned sewer brick, fully up to all dimensions, true and square, with all the faces at right angles, sharp clean edges, thoroughly hard burned clear through. All brick shall be free from bats; broken bricks, light hards, or other imperfect brick, shall be thoroughly culled before being delivered, be uniformly and evenly burned. The Contractor shall submit to the Engineer or Superintendent samples of brick, which if approved shall be retained, and all brick shall correspond to the sample.

**SECTION 25.**

**Construction Specifications.**

**No. 1. Test Holes.**

(a)

If required the Contractor shall dig not to exceed one 1) test hole for every running block of street along the line of the proposed conduit. These holes shall be dug to any depth not to exceed ten feet (10 ft.), and of any width not to exceed three feet (3 ft.), and of any length not to exceed the width of the street. The Contractor shall make no extra charge for any such test holes, but if more than one test hole per linear block is requested, or if

the dimensions shall be greater than those specified, the Contractor shall be entitled to extra compensation for all excavation over this amount.

(b) Notice to Commence Work.

For each and every section of conduit, for each manhole and for each lateral, the Engineer or Superintendent shall give to the Contractor a written notice, stating the time at which he shall commence work upon the section, manhole or lateral in question.

(c) Size of Excavation.

All trenches or excavations shall be dug of such size and to such depths as shall in the opinion of the Engineer or Superintendent give suitable and adequate room for the structures they are to contain. On the average, trench for conduit must be about 2 ft. in width by 4 ft. in depth, and excavations for manholes about 6 inches greater in dimensions than those of the vault upon Plan I, but in order to provide for the possibility of unforeseen street obstructions, the Engineer or Superintendent may direct the Contractor to open any trench for conduit, of any width up to 3 ft., and of any depth to 5 ft., measured below the street paving, and may direct for any manhole an excavation not to exceed 3 ft. greater in length and 2 ft., in breadth than the dimensions above specified, and of a depth not to exceed 10 ft. measured below the street paving. For laterals a trench 18 in. wide and 2 ft. in depth will usually suffice, but the Engineer or Superintendent may require the Contractor to open the trench not to exceed 2 ft. 6 in. in width and 4 ft. in depth. For any



and all such excavation the Contractor shall make no extra charge. In case the Engineer or Superintendent shall require the Contractor to open any trench or any excavation which is greater than the dimensions herein specified, he shall give the contractor a written order for such extra excavation which is over and above in amount herein called for, and this order shall authorize the Contractor to make the specified extra amount of excavation at the prices for extra work of Section 23, No. 6 *d*.

**No. 2. Way in Which Excavation Shall be Made.**

On receipt of notice to commence work, together with directions giving the location and size of the excavation, the Contractor shall remove the paving along the line specified and shall dig the excavations in accordance with the dimensions given. For each section the Contractor shall open the trench completely from one end to the other, including the manhole excavations at each end thereof, and shall carry all excavations completely down to the specified depth.

Upon the removal of the paving, the Contractor shall pile same neatly along the line of trench or shall make any other disposition of same as may be directed. He shall pile the excavated material along the side of the trench, provided the same can be done without unreasonable interference with traffic, but in crowded localities or if directed by the Engineer or Superintendent, the Contractor shall remove any and all excavated material whatsoever from the line of the trench, leaving the street free and clear, with the exception of the actual opening. The Contractor shall preserve all the material excavated, and

shall use the same for refilling and repaving as shall be directed.

The Contractor shall make all the requisite excavations as herein provided, in whatever materials, wherever found in the streets. If the Contractor shall encounter any rock, old masonry, walls, concrete, hard pan or other material, he shall make the excavation in same without extra charge. If the nature of the material is such as to require blasting, the Contractor shall conduct any and all such operations strictly in accordance with all city rules and regulations therefor. He shall use the minimum amount of explosive for the purpose, and in all cases blasts shall be carefully protected to prevent injury by flying débris. He shall use the most approved appliances and skilled labor which shall conduce to the safety of the public and of his employees in every manner whatsoever. The Contractor shall do all pumping and bailing necessary to keep the trench free from water and in proper condition to receive the ducts. He shall do all sheeting, bracing, shoring or supporting, and shall keep all excavations dry during such time as may be required for the proper setting of all concrete or masonry, all fencing and all other things, needful to constantly protect and maintain the sides and safety of the excavation, and to care for all gas pipes, water pipes, sewers, drains, electric conduits, railways or other structures encountered, and shall maintain and protect all buildings, railways and other structures which may be found during the progress of the work. He shall further provide all crossings and bridges which may be necessary to maintain travel uninterruptedly on all streets and alleys, and shall guard and watch all excavations in

complete accordance with all the rules and regulations of the City of ..... or any directions which may be in future given by the City authorities or the Police Department. At night all excavations shall be properly fenced, lighted and guarded to insure the safety of the public. During the progress of the work, any gas pipes, water pipes, sewers, drains, electric conduit, catch basins, buildings, railways or other structures which may be uncovered or undermined by the Contractor shall be restored and left by him in equally good condition, or if injured or harmed in any way, shall be replaced by him without extra compensation therefor, in as good condition as that in which they were found. During the progress of the work all supplies, materials, tools and machinery shall be neatly distributed along the line of the street to least obstruct the traffic or if directed the Contractor shall store all material, tools, machinery or supplies off the line of work, and in all cases particular care shall be given to providing free access to water hydrants and shut-offs and to arrange for free passage ways for the Fire Department. Upon the completion of any section of conduit, manholes or laterals the Contractor shall remove therefrom any sheeting, shoring or bracing which may have been introduced for the purpose of holding the sides of the trench or maintaining any street structures, unless the Engineer or Superintendent shall direct the Contractor in writing to leave same in place. If the Engineer or Superintendent shall elect to leave any sheeting, shoring or bracing in place, he shall give a written order to the Contractor authorizing such as extra materials and work, with extra compensation therefor, as per Section 23, No. 6 c.

**No. 3. Final Alignment and Grade of Excavation.**

Upon the completion of any excavation to the dimensions specified, the Contractor shall notify the Engineer or Superintendent that he is ready for final line and grade. The Engineer or Superintendent shall then drive one stake in the excavations for the manholes, and one stake along the line of conduit at intervals of about ten feet. In manhole excavations stakes shall be so driven as to locate the center of the manhole, while the top of the stakes shall be at the grade of the top of the bottom thereof. In the trench the stakes shall give the center line of the conduit, the top of the stakes indicating the top of the concrete foundation. In all cases the exact center line shall be indicated by a tack driven in the top of each stake. As soon as the stakes have been driven, the Contractor shall trim the sides and the bottom of the trench, in such a manner as to give adequate room to place the structures.

The Contractor shall make no extra charge for the final trimming or any excavation which may be necessary to bring the excavation to the proper line and grade, as given by the final stakes. In case the opening of any excavation shall disclose any obstacles that render it advisable in the judgment of the Engineer or Superintendent to change either line or grade or both, he shall have the right to make any and all such changes as he may see fit, and in so far as any such changes do not require the Contractor to open excavations of greater dimensions than called for in Section 25, No. 1 c, no extra charge shall be made. In case the grade of the conduit shall be raised, and if the Engineer or Superintendent shall order the

concrete foundation to be increased in thickness to accommodate such change, he shall give the Contractor an order for all extra concrete required over and above the amount hereinafter specified for foundations. But in case such change in grade shall be made by refilling the material excavated, no claim shall be made by the Contractor for any extra work for such change.

**No. 4. Obstacles.**

Whenever it shall become necessary to change the location, either temporarily or permanently, of any water pipes, gas pipes, sewers, drains, electric subways, electric mains, catch basins, railways or other structure encountered, the Contractor shall send notice of the existence of any such obstacles to the Engineer or Superintendent, and if in his judgment such changes are deemed necessary, he shall notify the owners or those in charge of such structures, and any and all changes shall be effected in accordance with the directions and under the supervision and subject to the approval of such owners or persons in charge. In case the Engineer or Superintendent shall call on the Contractor to do any of the work of the removal or changes in any street obstructions, the Contractor shall supply any and all work, labor, tools, appliances or material such as shall in the opinion of the Engineer or Superintendent be desired for this purpose. All such labor, work, tools or materials shall be the subject of an order for extra work, which shall be given to the Contractor by the Engineer or Superintendent in advance of the performance of the work, at the prices specified in Section 23, Nos. 5 and 6. For all time which

in the opinion of the Engineer or Superintendent the Contractor is delayed by the non-removal of any street obstructions, the Contractor shall be allowed a corresponding number of extra days' time over and above that herein stipulated for the completion of the entire work called for by this contract. If in the opinion of the Engineer or Superintendent any such time allowance is due, he shall give to the Contractor a certificate of extra time allowance, specifying the number of days.

**No. 5. Mortar.**

All mortar, either for concrete or for masonry, shall be mixed as follows :

A sample of the sand shall be tested to determine the percentage of voids by filling a measured vessel having a capacity of about 1 cubic foot, and then adding as much water as possible without causing the vessel to overflow, and noting the amount, which shall be deemed a measure of the voids. To prepare mortar such an amount of packed cement shall be taken as is equal to 125 per cent of the amount of voids thus shown and thoroughly mixed with sand. Enough water shall then be added (approximately one-third of the cement) and the whole mass thoroughly mixed. After proportions are thus determined the relative quantities of cement, sand and water, as thus shown, shall be used in all work. The relative proportion of water, cement and sand will be about one-third part of water, one of cement and two and one half of sand, for such cement and sand as is hereinbefore specified. The proportions thus given are only approximate, and as they will vary with the different kinds of sand and

cement which may be used, the exact proportions in each case shall be determined by the Engineer or Superintendent.

**No. 6. Concrete.**

The voids in broken stone used for concrete shall be determined as previously specified for voids in sand. After the amount of voids is ascertained, a proportion of cement mortar made as specified in Section 25, No. 5, equal to 140 per cent of these voids, shall be used. With the cement, sand and stone previously specified, the proportions for concrete will be one-third part of water, one part of cement, two and one half parts of sand and seven and one half parts of broken stone, but as the character of the broken stone may vary from time to time, the proportion of voids for each kind of stone used shall be measured, and the Contractor shall mix concrete in accordance with the instructions given by the Engineer or Superintendent after such determination.

**No. 7. Mixing.**

All cement-mortar and concrete shall be made by accurately measuring — not estimating — the proportions of the various ingredients of which they are composed, as directed by the Engineer or Superintendent. Mixing shall always be done on a mixing board or trough or by a mixing machine — never on the ground. For mortar the proper proportions of cement and sand shall be measured and thoroughly mixed by shoveling over five times, then — not previously — shall the proper proportion of water be added and the mass again mixed by shoveling at least five

times. Concrete shall be mixed by adding the specified quantity of mortar to the specified quantity of stone and shoveling at least five times. Mortar shall not be used that has been mixed for more than thirty minutes, and no concrete that has been mixed for more than forty-five minutes. No retempering or the addition of any material whatsoever to either the mortar or concrete shall be permitted after mixing has commenced.

**No. 8. Method of Laying Duct Material.**

**(a) HOLLOW BRICK OR SINGLE DUCT MATERIAL; BUTT JOINTS  
WITHOUT DOWELS.**

The contractor shall place upon the bottom of the trench a layer of concrete 3 inches thick to form the foundation. This layer shall be deposited uniformly and evenly, carefully leveled and scraped so that it shall present a uniform even surface, both longitudinally and transversely to line and grade. The concrete shall be thoroughly packed into place with suitable rammers not less than 6 inches square, weighing not less than 25 pounds, rammed until its surface slightly flushes, and on completion the foundation shall be level and even with the top of all grade stakes. After the concrete is placed, at least six hours shall be allowed for setting before any duct material is laid thereon, unless in the opinion of the Engineer or Superintendent the immediate placement of the conduit is necessary. If the Engineer or Superintendent shall direct the Contractor to place the conduit immediately, the Contractor shall protect the top of the concrete with sufficient planking so that it may not be injured. The duct material shall be laid by placing upon



the surface of the concrete foundation a thin coating of cement mortar about one-fourth inch in thickness, and the first layer containing the number of ducts horizontally specified in the directions of the Engineer or Superintendent shall be placed upon this bed of mortar and laid by line and level. As each piece is laid all of its sides shall be coated with cement mortar to form a solid joint with each neighboring piece, and at the same time the ends of each piece shall be similarly coated to make a sealed joint; no joints shall be laid dry or flushed. All hollow brick shall be laid upon a mandrel, not less than three inches in diameter and five feet in length, excepting in cases of curves where a mandrel three feet in length may be employed. The front end of this mandrel shall be supplied with a ring whereby the mason by means of a long hooked rod can draw it along, and the rear end with a washer of leather or rubber lightly fitting the ducts, the object of which is to scrape away any mortar that may accidentally enter. All hollow brick shall be laid so as to break joints in every direction, both longitudinally and vertically.

As soon as the first few feet of the lower layer of ducts are laid, a second layer shall be started and shall proceed simultaneously with the first, being laid to line and level. The laying shall proceed in a similar manner until such a number of horizontal layers is placed as is called for by the specifications for the particular section.

In laying pipe, care shall be taken to so place each piece that the bend, if any, shall be in a vertical plane. All sections of conduit shall be laid perfectly straight to line and grade, unless by special directions from the Engineer or Superintendent. In case it shall become necessary to

make any curves, either vertical or horizontal, the Engineer or Superintendent shall lay out all such curves, and the Contractor shall then lay the duct material exactly to the lines given. If necessary the Engineer or Superintendent may require the Contractor to provide a templet to insure accurate laying.

(b) HOLLOW BRICK OR SINGLE DUCT MATERIAL, BUTT ENDS WITH DOWELS.

When dowel butt ends are used all the requirements of Section 25, No. 8 *a*, shall be observed exactly as therein specified, and in addition after each piece is laid a dowel pin shall be inserted into each of the dowel holes in the open end thereof, and the succeeding piece centered by these pins.

(c) HOLLOW BRICK OR SINGLE DUCT MATERIAL—SOCKET ENDS.

When socket ends are used, all the requirements of Section 25, No. 8 *a*, shall be observed, and in addition special care shall be taken to coat the male end of each piece uniformly and thinly with mortar, and to drive it firmly home with the female end of the preceding piece. With dowel or socket ends the use of the mandel in laying may be omitted, if so directed by Engineer or Superintendent.

(d) MULTIPLE DUCT MATERIAL.

Multiple Duct Material shall be laid under the provisions of Section 25, No. 8 *a*, except that no mortar shall be used between the ends of each piece, but instead each joint between successive pieces shall be made by

wrapping a strap of burlap 12 in. wide and long enough to make  $2\frac{1}{2}$  complete turns around the ends of the piece to be jointed. Prior to wrapping the burlap shall be dipped into melted asphalt, as hot as possible without danger of burning the burlap, and applied hot to the duct material. No laying mandrel shall be used with multiple duct material.

(e) CEMENT LINED PIPE.

Cement lined iron pipe shall be laid by providing concrete foundation as already specified in Section 25, No. 8 *a*. Upon this foundation the cement lined iron pipe shall be laid in a manner similar to that specified under Section 25, No. 8 *a* and *c*, but in addition sufficient mortar shall be used to fill completely all of the voids between each round piece of pipe and any and all of its neighbors. No mandrel shall be used.

(f) CREOSOTED WOOD—PUMP LOG.

Creosoted wood duct material shall be laid without any foundation or encasement of concrete. After the trench is excavated the bottom shall be rammed solidly to compact it and then shall be leveled off and graded in the same manner as specified for the concrete foundation. The creosoted wood duct material shall then be laid upon the bottom of the trench to line and grade, as specified in Section 25, No. 8 *a* and *c*, excepting that no mortar, cement or concrete shall be used. Previous to joining the pieces the tenon of each piece shall be painted with hot asphalt and then driven solidly home into the mortise of the preceding one. At each joint one stake  $1\frac{1}{4}$  in. thick

and 3 in. wide shall be driven into the bottom of the trench close to and on each side the duct material to hold the same in place. These stakes shall be of such a length as to be driven into solid material. The top of these stakes shall be driven flush with the top layer of ducts and then shall be secured by a cross batten of 1½ in. creosoted lumber 3 in wide, secured to each stake by two wire nails 3 in. in length. The lumber and nails for the stakes thus specified shall be included in the term "Duct Material."

(g) IRON PIPE.

Iron pipe duct material shall be laid in the same manner as specified for cement lined pipe Section 25, No. 8 *e*, excepting in the case of laterals when the concrete encasement shall be omitted. The joints shall be made by screwing each successive length of pipe into the coupling placed on the preceding one as required in Section 24 No. 6.

(h) CEMENT CONDUIT.

Cement conduit shall be laid as specified for cement lined pipe, Section 25, No. 8 *e*, but in addition shall be laid on a mandrel.

(i) LATERALS.

Laterals shall be made of any form of duct material, as may be directed by the Engineer or Superintendent, and each lateral shall be laid in the same manner as is specified for the duct material of which it is composed, except that the concrete foundation and encasement shall be omitted. One end of each lateral shall commence at some

distributing point, such as the terminal pole of an aerial line, or on the inside wall of a building. The other end of each lateral shall terminate in some manhole or in some duct of the conduit.

**No. 9. Encasement.**

After all the duct material is laid in any section, a period of not less than six hours shall be allowed for mortar to set before the concrete encasement is put in, unless the Engineer or Superintendent shall direct the Contractor to proceed immediately therewith. The concrete encasement shall consist of a layer of concrete two inches in thickness on each side of the ducts and three inches on the top, so that when joined to the foundation it shall form a complete inclosure for the conduit. This concrete shall be deposited, on each side of the conduit, and on the top thereof, and carefully rammed into place, great care being exercised not to injure or break any of the joints of the duct material. After the concrete encasement is placed, a period of six hours shall be allowed for the setting thereof, before the trench is refilled, unless the Engineer or Superintendent shall direct immediate refilling.

**No. 10. Refillment of Trench.**

The contractor shall refill into the trench the material previously excavated. This material shall be refilled in layers not to exceed 6 in. in thickness, carefully deposited on and around the concrete, in such a manner as not to injure the bond thereof and each successive layer shall be thoroughly and carefully rammed into place with rammers similar to those specified for ramming concrete. If re-

quired, the Contractor shall puddle any and all refill. Upon the completion of each section of conduit and each lateral, the Contractor shall at once thoroughly and carefully clean up the street and sidewalks. He shall remove all surplus dirt, paving material and all tools, materials and supplies of whatever nature and description, and in every respect except the strip of paving removed, the street shall be restored to as good condition as before the opening was made, and shall meet the approval of the city authorities in all particulars.

**No. 11. Temporary Paving.**

(a) As soon as the refillment of the trench is completed, the Contractor shall restore the paving in such a manner as to make the streets safe and suitable for traffic. If any of the cross walks, paving blocks or other paving material has become lost or injured, or is in any way unsuitable for this purpose, the Contractor shall supply, at his own expense, a sufficient amount of suitable paving material to make good the street. In this replacement of paving the Contractor shall not be required to make finished and permanent repaving, but shall merely replace in such a manner as is necessary to allow for the refill to settle and compact itself sufficiently to warrant permanent repaving.

(Cancel paragraph (b) if paving is done by conduit contractor.)

(b) It is further specified that on the replacing of the pavement in the temporary manner thus specified, the work of the Contractor upon this section of the conduit, in so far as the street paving is concerned, shall cease, and

that the future and final repaving of the same in a manner suitable and acceptable to the city authorities shall be done by the company.

(Cancel paragraphs No. 12 (a) and (b) if paving is done by company.)

**No. 12. Permanent Repaving.**

(a) After the temporary paving, as specified in Sec. 25, No. 11 *a*, is done, the Contractor shall allow such a time as may be directed by the Engineer for the settlement and compacting of the refill before permanent repaving. When this time has elapsed, the Contractor shall repave all excavations with the same class of paving materials as have been removed. All curb stones, gutter stones, flag-stones or sidewalks, and all street paving material which may have been displaced, shall be put back in as good or better shape than before the removal. In all paving work the standard specifications or requirements of the City of .....shall be followed; and when the final paving is complete the street shall be finished, cleaned and left in as good, or better, condition than before the openings were made, and shall in every particular meet the approval of the city authorities.

(b) In all excavations the Contractor shall exercise due care not to move or disturb the pavement in excess of that required for the opening specified, and shall be responsible for any and all paving which is disturbed or moved, that is more than six inches away from the line of the excavation as laid out by the Engineer, and in the event of the disturbance of any pavement beyond the six inches herein specified, the Contractor shall re-

place all such moved or disturbed pavement at his own expense.

If, within a period of one year after the final repaving of any opening, any settlement, heaving or displacement of any of the paving, curb stones, gutter stones, cross walks or sidewalks shall occur, the Contractor shall repair and make good the same in a manner satisfactory to the city. And to meet the cost of any such repair work, it is hereby agreed that an amount not to exceed 25% of the estimated cost of paving permanently the whole surface of pavement disturbed by the work specified in this agreement shall be withheld by the company from any amount which may become due to the Contractor on account of this contract, for a period of one year after the entire completion of the work. And that during said period of one year the company shall notify the Contractor of any repairs or repaving which may be necessary on account of said work, and the Contractor shall at once, on receipt of such notice, make any and all such repairs, in a manner satisfactory to the city. If the Contractor shall fail upon the receipt of such notice to make the repairs therein stipulated within such a time as shall be required by the city, the company may make the necessary repairs and may deduct the cost of such repairs from the amount held as herein specified. At the expiration of one year from the entire completion of the work herein called for, and upon the completion of any and all repairs to any and all portions of the streets which may have been opened for the construction of the work herein specified in a manner satisfactory to the city, the company shall pay to the Contractor any and all moneys which may remain over and



above the cost of said repairs, from the amounts withheld as above specified.

**No. 13. Construction of Manholes.**

*(a) BRICK MANHOLES.*

The bottom shall consist of a layer of concrete 6 inches in thickness, large enough to cover the entire area of the manhole and extend under the walls thereof, as shown upon Plan II. C. This concrete shall be mixed in the proportions and deposited as specified in Sec. 25, No. 6. After the concrete bottom is in place at least six hours shall be allowed for setting before the masonry is commenced, and the Contractor shall protect the surface of the concrete by suitable planking and then shall proceed with the walls, which shall be built essentially as shown by Plan II., A and B, so as to construct a vault about 4 feet wide, 6 feet long and 5 feet high inside with curved walls uniformly 8 in. in thickness. The brick masonry shall be laid in cement mortar made as specified under Sec. 25, No. 5. Each brick shall be laid in a full bed or mortar upon all sides; there shall be no slushing of joints after bricks are placed. The masonry shall be laid in alternate courses of headers and stretchers. As nearly as may be the center of each end the wall shall be corbeled as shown, to afford entrance for the ducts, but the exact location of the ducts in each wall shall be given by the Engineer or Superintendent at the time of building. The size of the entrance shall depend upon the number of ducts shall be specified for each wall separately. When the mason work has reached the level of the under side of the ducts, the Contractor shall then build the end of the

conduit into each end wall, unless the Engineer or Superintendent shall direct the manhole to be completed, and the conduit to be subsequently built. If such instructions be given, the Contractor shall leave a suitable opening in each end wall and shall proceed to complete the manhole, and after completion he shall build in the conduit.

The four walls shall be carried up uniformly, and as they are built the exterior of each wall shall be plastered thoroughly with cement mortar to a thickness of not less than  $\frac{1}{2}$  in. The walls shall be built 5 feet high above the top of the concrete bottom, and shall then be leveled off evenly to receive the top. All masonry shall be laid plumb and true to line and level with not over  $\frac{3}{8}$  in. joints completely filled with cement mortar, accurately curved to trowel, as shown, and shall be in every respect first class brick masonry. The roof will vary according to location in the street, and may be either flat or arched, and may be composed either of concrete or brick laid upon iron.

(b) **ARCHED CONCRETE ROOF.**

This shall be made as shown by Plan I, A and B, by setting inside of the walls and level with the top thereof, an appropriate form so constructed that after the top is completed the form may be withdrawn through the opening for the cover. After this form is in place a layer of concrete eight in. in thickness, shall be placed on the top of the form and thoroughly and solidly rammed into place. This concrete shall be allowed to set for 6 hours before any refilling is made.

(c) FLAT CONCRETE ROOF.

Flat concrete roofs shall be made exactly as specified in Section 25, No. 13 *b*, except the form shall be so made as to give a flat not an arched roof.

(d) BRICK AND IRON ROOF.

Brick roofs shall be built by placing across the walls a series of iron beams made of angle iron, as shown on Plan II, A, B and C, and as specified in the attached Bill of Materials headed Brick Manholes. If the Contractor desires he may substitute any other equally strong iron shape such as old rail channels, angles, etc., if approved by the Engineer or Superintendent.

(e) CONCRETE MANHOLES.

Concrete manholes shall be built of the same general form and shape as shown in Plan I, A, B and C, the bottom shall be put in, in the same manner as specified already, in Section 25, 13 *a*, and after it is in place and has had six hours' time to set, the Contractor shall place thereon the appropriate form for shaping the concrete. This form shall be made of first class dressed lumber accurately and carefully built in a substantial manner, to withstand without deforming the ramming of concrete. It shall be so built as to easily retain its shape and readily taken apart so the largest piece can be removed through the cover hole. The forms shall be smooth and true so that after the concrete is rammed a finished surface be produced. The Contractor shall constantly maintain the forms in good condition so that they shall yield first class manholes. After the form is properly set the Contractor shall deposit

around it the necessary concrete to give a wall 8 in. in thickness. This concrete shall be made as specified in Section 25, No. 6, and shall be filled around the form in layers not exceeding 6 in. in thickness, thoroughly rammed in place sufficiently to show a slight flushing. The placing of the concrete shall be uniformly and evenly carried around the entire circumference of the form, layer after layer, until the form is completely covered. To retain the outside of the concrete, the Contractor may either use the earth walls of the excavation or sheeting as he may see fit. The concreting shall be continued without stopping so as to complete the entire manhole at a single operation.

After the roof is completed 6 hours shall be allowed for setting, then a ring of brick masonry of sufficient size and height to raise the cover flush and level with the street pavement shall be built around the opening for the cover and the iron cover be set in its place, as shown on Plan I. After the settling of the cover the refilling of the manhole excavation shall be done. In this refilling the excavated material shall be deposited in layers of about 6 in. in thickness uniformly all around the manhole walls and shall be solidly rammed into place. If directed, the Contractor shall puddle all the refill. This refilling shall extend up to and around the cover to the proper height to receive the paving, which shall then be replaced as specified in Section 25, No. 11.

(f) CHANGES IN MANHOLES.

The Engineer or Superintendent shall have the right at any time to change the size and shape of any manhole to

any extent that shall in his judgment be deemed expedient. The Contractor shall at all times build such special manholes in accordance with any supplementary drawings, plans or instructions, without extra charge, provided such changes do not require the Contractor to supply a greater amount of masonry or concrete than is called for by Plan I and Bills of Material for standard manhole. In case the directions shall increase the volume of masonry in any manhole, the Engineer or Superintendent shall give to the Contractor an order for all extra material so demanded, and this order shall authorize payment to the Contractor of such an amount as shall cover the difference between the amount of masonry in the standard manhole and that in the one called for. This extra compensation shall be at the rate hereinbefore specified in Section 23, No. 6 *a* and *b*.

(g) SEWER CONNECTIONS.

The bottom of such manholes as the Engineer or Superintendent shall direct shall be provided with a drain connecting with the nearest street sewer. This drain shall be made of a sufficient amount of standard 4 in. tile drain pipe. The Contractor shall supply the required pipe, make the necessary excavation, lay the pipe, connect the outer end thereof to the street sewer, and connect the inner end to a sewer trap approved by the Engineer and Superintendent and set same in manhole floor, and repave the excavation. All of this work shall be done by men holding "Sewer Permits," and shall be in accordance with all the City rules pertaining to sewer connections and to the satisfaction of the City authorities. For all such sewer connections the Contractor shall apply for,

take out and pay to the City the usual fee for a sewer permit, and shall file with the Company the receipt for each and every such connection as evidence of his compliance with the City rules.

(h) TREATMENT OF STRUCTURES ENTERING MANHOLES.

The location of the conduits and manholes shall be, at all times, so planned as to avoid, as far as possible, carrying any gas pipes, water pipes, drain pipes, foreign electric subways or other street structures inside of the walls of the manholes, but where it is impossible to avoid the entrance of such structures, the Contractor shall take particular pains in building the walls of the manhole or other parts of the masonry thereof, around such structures. In any instance where gas pipe, water pipe, electric subway, Edison tubes, drain pipes or other structures shall pass through any portion of any manhole, the Contractor shall turn a complete circular arch in the mason work of each wall intersected by such structure entirely around such structure. This arch shall be so built as to give not less than  $1\frac{1}{2}$  in. clearance between the foreign structure and the mason work, solidly built of brick set upon edge, laid in cement mortar with closed joints, and shall allow the foreign structure to pass through the manhole without touching any portion of the walls thereof.

(i) POINTING OF BRICK WORK ; AND ENTRANCE OF THE DUCTS.

After each manhole is entirely completed and conduits built into place in each end wall, the Contractor shall go over and finish the same. The finish shall consist in pointing up with neat cement mortar all joints in brick

work, and entrance of ducts, and the junction between the masonry of the sides and the bottom and top, the entrance of the sewer trap and the junction of the cover with the manhole top. The pointing shall be done in a neat and workmanlike manner so as to seal and complete all joints. After the pointing is done the manhole shall be thoroughly cleaned out, the bottom-sides and top, including the entrance to the ducts, smoothed off so as to leave the work in a neat and shipshape manner in every respect.

(j) **PROVISION FOR RENDERING CONDUIT OR MANHOLES WATERTIGHT.**

In case any conduits or manholes shall be laid in a wet location and where standing water is encountered in the excavation of trenches, the Contractor shall excavate a proper sump and dig along the bottom and outside of the excavation a proper drain and provide sufficient pumping facilities so that such excavation may be kept free from water during the setting of the concrete or masonry. In such cases the Contractor shall take particular pains with the manufacture and placing of concrete so that when the work is completed all portions of the conduits and all the manholes shall be water tight. In case any portion of conduit or any manhole shall after completion be found to leak, the Contractor shall reopen the excavation and plaster, or in any other manner satisfactory to the Engineer or Superintendent stop any and all such leaks or incursions of water.

**SECTION 26.**

**Rodding.**

After the completion of each section of conduit together with the adjacent manholes and each lateral, the Con-

tractor shall *rod* each and every duct. This process shall consist in pushing a series of rods of wood or metal composed of sections of such length as may be handled inside the manhole and arranged to be easily joined together through each duct. These rods shall be supplied by the Contractor. After the rods are pushed through a duct a rope shall be attached to the rear end of the rods to enable a mandrel to be pulled through the duct, in order to ascertain whether the duct is free and clear, and to remove any surplus mortar, concrete or other obstacles which may have entered therein. This mandrel shall consist of a piece of iron pipe about  $2\frac{1}{2}$  in. in diameter, supplied with appropriate hook and eye at either end, to which the proper ropes may be attached, and furnished at both ends with a sharp cutting edge of steel. The mandrel shall also be supplied with a steel brush not less than three inches in diameter. A specimen mandrel will be furnished to the Contractor by the Company and the Contractor shall build and supply as many mandrels, exactly in accordance therewith, as may be necessary. If, during the rodding the Contractor shall find any obstacle that shall prevent the passage of the mandrel, he shall reopen the street, find the obstruction, dislodge the same, repair the conduit, replace the concrete encasement, refill the excavation, replace the pavement, and then shall repeat the process of rodding until the mandrel shall pass easily through each and every duct. After the mandrel has been pulled through each duct, the Contractor shall pull into and leave in such ducts as may be specified by the Engineer or Superintendent a piece of No. 10 B. W. G. galvanized iron wire long enough to extend entirely through each



duct and project about 6 in. from each end thereof. The Company shall deliver to the Contractor at its storehouse all the wire that shall be required for the purpose, but the Contractor shall haul the wire to the work and introduce the same into the ducts without extra charge. Finally the Contractor shall plug each end of each duct with a hardwood plug of sufficient size to firmly stop the ends. This plug shall be of hardwood, turned true and smooth, shall so fit the duct that it cannot be forced inside thereof, and shall project at least one inch inside the end of the duct and two inches outside thereof. The plugs shall be soaked in water for at least twelve hours, before they are put in place so that they may not swell and split the ducts.

IN WITNESS whereof the parties to these presents have caused the same to be signed by their respective executive officers and their respective corporate seals to be hereto affixed the day and year first above written.

(Signature first party)

.....  
 .....

(Signature second party)

.....  
 .....

(Witnesses)

.....  
 .....  
 .....

SECTION 27.

Bond.

KNOW ALL MEN BY THESE PRESENTS  
 THAT WE.....  
 .....as principal, and  
 .....we as surety,  
 .....are held and firmly  
 bound unto the.....  
 COMPANY, of....., in the sum of.....  
 .....Dollars, to be paid to the.....COM-  
 PANY, its successors and assigns, for which payment  
 well and truly to be made, we bind ourselves, our heirs,  
 executors, administrators and successors jointly and sever-  
 ally by these presents.

Sealed with our seal and dated at this.....day of  
 ....., 1900.

THE CONDITION OF THE ABOVE OBLIGATION IS  
 SUCH THAT

Whereas the said above bounden.....  
 has entered into a certain agreement of date herewith  
 in which the.....is party of  
 the first part, and the said.....is the  
 party of the second part, for the full terms used and par-  
 ticulars hereof express reference is hereby made to such  
 agreement, and by this reference it is made a part hereof,  
 to which this bond is annexed.

NOW THEREFORE, if the said.....shall  
 in all things fully and faithfully keep and perform said

agreement and each and every term and part thereof, then this obligation shall be void, otherwise it shall remain in full force.

WITNESS OUR NAMES AND SEALS

..... Seal.  
..... Seal.  
..... Seal.

(Witnesses)

.....  
.....  
.....

SECTION 28.

**Bills of Material.**

(a) CONCRETE MANHOLE, FLAT CONCRETE ROOF.

Excavation and removal of earth .....375 cubic feet  
Concrete .....125 cubic feet  
Cover and frame .....1  
Repaving .....6 square yards

(b) CONCRETE MANHOLE, ARCHED ROOF.

Excavation and removal of earth.....425 cubic feet  
Concrete .....130 cubic feet  
Cover and frame .....1  
Repaving.....6 square yards

(c) BRICK MANHOLE, FLAT CONCRETE ROOF.

Excavation and removal of earth .....375 cubic feet  
Concrete .....52 cubic feet  
Brick .....1600

*CONDUIT BUILDING.*

175

Cover and frame .....	1
Repaving.....	6 square yards

(d) **BRICK MANHOLE, FLAT BRICK AND IRON ROOF.**

Excavation and removal of earth .....	375 cubic feet
Concrete .....	19 cubic feet
Brick.....	2200
Iron work .....	500 pounds
Cover and frame .....	1
Repaving.....	6 square yards

(e) **SEWER TO ANY MANHOLE (AVERAGE).**

Excavation and refilling.....	25 cubic feet
4 in. sewer pipe.....	16 linear feet
4 in. sewer trap .....	1
Repaving .....	5 square yards



# INDEX.

NUMBERS REFER TO PAGES

- Acceptance of Work, 123.  
Access to Work, 116.  
Annual Charges, 102.  
Arched Concrete Roof, 165.  
Asphalted or Bituminized  
Wood Pulp Ducts, 7.
- Bills of Material, 174.  
Bond, 173.  
Box, Iron Service, 70.  
Brick and Iron Roof, 166.  
Brick Manhole, 51.  
Brick Manhole, Flat Brick and  
Iron Roof, 175.  
Brick Manhole, Flat Concrete  
Roof, 174.  
Briguettes, 143.  
Broken Stone, 145.  
Built-in Systems, 3.
- Carrier for Duct, 72.  
Cement Conduit, 142, 159.  
Cement Ducts, 7, 15.  
Cement Lined Pipe, 16, 158.  
Cement Lined Pipe, Duct Ma-  
terial, 136.  
Cement Pipe, Duct Material,  
137.  
Cement, Testing, 142.  
Changes in Location, 111.  
Changes in Manholes, 167.  
Company, 109.  
Company's Right to Assume  
Work, 121.
- Competent Men, Suitable Tools,  
and Acceptable Materials,  
116.  
Concrete, 154.  
Concrete Manhole, 87.  
Concrete Manhole, Arched Roof,  
174.  
Concrete Manhole, Flat Concrete  
Roof, 174.  
Concrete Materials, 166.  
Condition of Final Acceptance,  
124.  
Conditions of Payment, 125.  
Conduit Building, 107.  
Conduit Cost, 84, 96, 97.  
Conduit, Electrolysis Proof,  
40-43.  
Conduit Foot, Meaning, 126.  
Conduit, Hollow-brick, 26.  
Conduit, its Meaning, 110.  
Conduit-laying, 22.  
Conduit, Single-duct, 35.  
Conduit, The Valentine, 11.  
Construction of Manholes, 164.  
Construction Specifications, 146.  
Contract, 109.  
Contract and Specifications for  
Underground Conduits, 108.  
Contract Prices to be Paid per  
Conduit Foot, 126, 127.  
Cost, Constant, per Conduit  
Foot, for Manholes, 88-93.  
Cost of Conduit, 84, 96, 97.  
Cost of Brick Conduits, 85.

- Cost of Broken Stone Conduits, 85.  
 Cost of Cast Iron Conduits, 85.  
 Cost of Cement Conduits, 85-94.  
 Cost of Conduits, Labor, Skilled and Unskilled, 85.  
 Cost of Conduits, Lumber, 85.  
 Cost of Conduits, Paving Materials, 85.  
 Cost of Sand Conduits, 85.  
 Cost of Wrought Iron Conduits, 85.  
 Cost of Duct Material Conduits, 85.  
 Cost of Duct Material in Place, in Dollars, 95.  
 Cost of Manholes, Brick, with Concrete Roof, 86.  
 Cost of Sewer Connections, 87.  
 Cost of Street Excavation per Conduit Foot, in Dollars, 92.  
 Cost per Duct Foot, Average, 98.  
 Cover, Manhole, 58, 59, 61, 62.  
 Creosoted Wood, Pump Log, 158.  
 Creosoted Wood Duct Material, 138.  
 Curve Pipe, 20.  
 Damages for Delay in Completion, 121.  
 Definitions, 109.  
 Delivery of Material Supplied by Company, 112.  
 Depreciation and Maintenance, 102.  
 Description and Location, 110.  
 Dimensions of Multiple Duct Pieces, 136.  
 Distribution, 65.  
 Distribution, Aerial, 65.  
 Distribution, Alley-line, 67.  
 Distribution, Block, 65.  
 Distribution, Housetop, 68.  
 Distribution, Tile-Service Box with Iron Surface Cover, 69.  
 "Drawing-in Systems," 4.  
 Duct-connection, 71.  
 Duct-curve, Multiple, 35.  
 Duct, Distributing, 72.  
 Duct-forms, Multiple, 36.  
 Duct-groupings, 39.  
 Duct, its Meaning, 110.  
 Duct Material, 7, 85, 112, 160.  
 Duct Material, its Meaning, 110.  
 Duct, The Francis, 19.  
 Duct, The Valentine, 7, 11.  
 Duct, Asphalted or Bituminized Wood-Pulp, 7.  
 Ducts, Cement, 7.  
 Ducts, Creosoted wood, 13, 14.  
 Ducts, Hollow brick, 23.  
 Ducts, Multiple, 42.  
 Ducts, Round hole, 37.  
 Ducts, Vitrified clay, 7.  
 Ducts, Wood, 7.  
 Encasement, 160.  
 Ends, Okonite, 71.  
 Errors in Plans or Specifications, 115.  
 Estimates, 125.  
 Excavations, 148.  
 Extra Work, 122.  
 Final Alignment and Grade of Excavation, 151.

- Final Payment, 125.  
 Fineness, Test, 143.  
 Flat Concrete Roof, 166.  
 Foundation for Valentine Conduit, 12.  
  
 General Contract and Specifications for Underground Conduits, 108.  
 Hollow Brick, 23, 24, 25, 27, 134, 155.  
 Hollow Brick or Single Duct Material, 134.  
 Hollow Brick or Single Duct Material. Butt Joints without Dowels, 155.  
 Hollow Brick or Single Duct Material. Socket Ends, 157.  
 Hollow Brick or Single Duct Material. Butt ends with Dowels, 157.  
  
 Iron Pipe, 159.  
  
 Lateral, its Meaning, 110.  
 Laterals, 157.  
 Legal Authority, 118.  
 Liens upon the Work, 120.  
 Lines, Back Lot, 67.  
  
 Maintenance, 104.  
 Mandrel for Hollow brick, 24.  
 Manhole, Arch brick, 57.  
 Manhole, Brick and Flat Iron roof, 175.  
 Manhole, Brick, Flat Concrete Roof, 174.  
 Manhole, Concrete Arched Roof, 174.  
 Manhole Cost, Brick, Brick Roof, 86.  
 Manhole Cost, Brick with Concrete Roof, 86.  
 Manhole, Flat Concrete Roof, 174.  
 Manhole Frame and Cover, 60, 61.  
 Manhole, its Meaning, 110.  
 Manhole, Waterproof, 63.  
 Manholes, 45—50, 56.  
 Manholes, Lateral Connection, 66.  
 Material Specifications, 134.  
 Method of Laying Duct Material, 155.  
 Method of Testing, 142.  
 Mixing, 154.  
 Mortar, 153.  
 Mouse, 83.  
 Multiple Duct Material, 27, 39, 136, 157.  
 Notice to Commence Work, 147.  
 Number of Ducts, 100.  
  
 Obstacles, 74, 152.  
 Okonite Ends, 71.  
 Orders to Contractor, 115.  
 Permanent Repairing, 162.  
 Pipe, Cement-lined, 16.  
 Pipe Curve, 2.  
 Pipe, Subway, Cement-lined, 18.  
 Pointing of Brick Work, and Entrance of the Ducts, 169.  
 Pole, Distributing, 67.  
 Power of Engineer, or Superintendent, 113.  
 Preliminary Inspection, 122.  
 Prices for Brick Manholes, 128.  
 Prices for Concrete Manholes, 128.  
 Prices for Conduits, 126.  
 Prices for Extra Work, 133.



- Prices for Sewer Connection, 133.
- Prices for Special Extra Material and Labor, 133.
- Prices for Work, 126.
- Provisions for Rendering Conduit or Manholes Watertight, 172.
- Pump-Log, Round, 9, 138.
- Pump-Log, Square, 9, 138.
- Quantity and Type, 2.
- Rail Roof, 52, 53, 55.
- Rate of Delivery, 145.
- Refillment of Trench, 160.
- Replacement of Defective Work, 118.
- Responsibility of Contractor, 119.
- Rodding, 170.
- Roof Rail, 52, 53.
- Sand, 145.
- Service, Tile, 69, 70.
- Setting Tests, 144.
- Sewer Connections, Cost, 87.
- Sewer Connections, 168.
- Sewer to Any Manhole, Average, 175.
- Single Duct Material, 134, 155.
- Size of Excavation, 147.
- Small Manholes, 63.
- Storage, 144.
- Street Excavation, Cost, 92.
- Subletting or Assignments, 120.
- Subway, 34-Duct, 41.
- Systems, Built-in, 3.
- Systems, "Drawing in," 6.
- Temporary Paving, 161.
- Ten by Ten, 23.
- Test Holes, 77, 144.
- Test Pits, 79.
- Testing Cement, 142.
- Time of Commencement and Completion, 121.
- Treatment of Structures Entering Manholes, 169.
- Type and Quantity, 2.
- Valentine Conduit, 10, 140.
- Valentine Duct Material, 140.
- Vaults, 45.
- Ventilation, 78.
- Ventilation, Artificial, 80, 81.
- Ventilation, Natural, 80, 81.
- Vitrified Clay Ducts, 7, 21.
- Way in which Excavation Shall be Made, 148.
- Wire Plant, 1.
- Wood Ducts, 7.
- Work to be Done in Accordance with Law and City Regulations, 119.
- Work to be Done in Accordance with Plans, Specifications, and Instructions, 114.
- Wrought Iron Pipe Duct Material, 141.

